

WM DO NOT REMOVE



U.S. Department  
of Transportation

Urban Mass  
Transportation  
Administration

Automation

in public transportation



Fiscal Year 1982

UMTA Technical Assistance

### **NOTICE**

This document is disseminated under the sponsorship of the Department of Transportation in the interest of information exchange. The United States Government assumes no liability for its contents or use thereof.

The United States Government does not endorse products or manufacturers. Trade or manufacturers' names appear herein solely because they are considered essential to the object of this report.

August 1983

UMTA-MA-06-0086-83-1  
DOT-TSC-UMTA-83-39



U.S. Department  
of Transportation

**Urban Mass  
Transportation  
Administration**

# Innovation

in public transportation

**Fiscal Year 1982**

**UMTA Technical Assistance Program Directory**





# Table of Contents

|   |     |  |     |
|---|-----|--|-----|
| <b>Introduction</b> .....                             | 1   | Operations and Maintenance Support .....   | 115 |
| <b>1. Bus and Paratransit Systems</b> .....           | 4   | <b>7. Information Services</b> .....   | 121 |
| Bus and Bus Subsystems Technology .....               | 5   | Section 15 Information .....   | 122 |
| New Bus Equipment Introduction .....                  | 6   | Technical Information Services .....   | 122 |
| Energy and Propulsion .....                           | 7   | <b>8. National Cooperative Transit Research and Development Program</b> .....                                  | 127 |
| Paratransit Technologies .....                        | 8   | Research Topics and Proposals .....  | 128 |
| <b>2. Rail and Construction Technology</b> .....      | 16  | Active NCTRP Projects .....  | 128 |
| Requirements Analysis, and Evaluation .....           | 16  | <b>9. Safety and Security</b> .....  | 134 |
| Systems Integration and Deployment .....              | 17  | System Safety and Security .....   | 134 |
| Vehicle and Equipment Technology/STARS .....          | 23  | Safety Information .....   | 136 |
| Construction Technology .....                         | 27  | Safety Research .....  | 137 |
| <b>3. New Systems and Technology</b> .....            | 45  | <b>10. Policy and Program Development</b> .....  | 141 |
| Advanced Group Rapid Transit (AGRT) .....             | 46  | Policy Development .....   | 141 |
| Other Projects .....                                  | 47  | Policy Research .....  | 142 |
| <b>4. Service and Methods</b> .....                   | 53  | <b>11. University Research and Training Grant Program</b> .....  | 146 |
| Transportation Services for Special User Groups ..... | 54  | University Centers for Transit Research and Management Development .....                                       | 147 |
| Fare and Pricing Policies .....                       | 56  | FY82 Project Grants .....  | 148 |
| Marketing Techniques .....                            | 64  | <b>APPENDIX A Sources of Technical Assistance Information</b> .....  | 154 |
| Conventional Transit Service Innovations .....        | 64  | <b>APPENDIX B Urban Mass Transportation Grants and Contracts: Application and Procurement Procedures</b> ..... | 157 |
| Paratransit Services .....                            | 68  | <b>Agency/Contractor Index</b> .....   | 162 |
| Rural Transportation .....                            | 73  | <b>Subject Index</b> .....   | 167 |
| <b>5. Planning and Analysis</b> .....                 | 88  | <b>NTIS Forms</b> .....  | 169 |
| Transportation Planning Analysis Methods .....        | 89  |  |     |
| Transit Operations Analysis Methods .....             | 90  |  |     |
| Special Planning Studies .....                        | 92  |  |     |
| <b>6. Management Resources</b> .....                  | 112 |  |     |
| Human Resources Development .....                     | 113 |  |     |
| Management Training Courses .....                     | 113 |  |     |



## Introduction

This directory contains descriptions of technical assistance projects sponsored by the Urban Mass Transportation Administration (UMTA) of the U.S. Department of Transportation (DOT). Its purpose is to inform the public and especially the transit industry on the nature and scope of work which is underway to assist State and local agencies in improving services and reducing the cost of public transportation. Under the program, technical assistance is provided in a broad range of disciplines and fields of knowledge that are essential to transit, including analysis, planning, demonstrations, management, vehicles, equipment, and facilities.

Technical assistance is furnished by UMTA primarily by providing information about and by sponsoring the development and introduction of improved techniques, equipment, and facilities. Information is disseminated by means of technical reports and other publications and by workshops and training courses. In addition to initiating the development of new techniques and equipment, the technical assistance program provides funding to transit operators to help evaluate and introduce innovations and new products by the private sector.

UMTA technical assistance concentrates on common management problems and technological needs of the transit industry, seeking broad applications to improve productivity, safety, and performance. The program supplements private initiative in the equipment, construction, and consulting industries where technological risks or market size do not produce incentives for privately financed research

and development in proportion to the benefits which can be achieved nationally.

Another important UMTA role consists of accelerating the flow of information on solutions and improvements which have been developed locally and can be adopted by a large proportion of the transit community. In this role, UMTA assists the transit community by serving as a clearinghouse for current information on the state-of-the-art and problem-solving resources. In addition to collecting, organizing and disseminating useful technical and management information, UMTA also sponsors demonstrations, independent evaluations, peer reviews, seminars, and site inspections when such activities are necessary for effective transfer of new techniques.

The current technical assistance program is based on needs and problems expressed by State and local agencies through a number of channels including: conferences and workshops, industry liaison boards, special user advisory groups, and general solicitations. Where problems are insufficiently defined or the cost-effectiveness of innovation is unclear, specific studies and surveys are undertaken with the cooperation and full participation of the transit industry. The UMTA regional offices support this communication process by providing a contact point for requesting technical assistance and by participating in project selection. The resulting higher levels of communication have enabled UMTA to direct its resources to programs which are more immediately useful to local agencies in improving their productivity.

Highlights for FY82 include the establishment of eight University Centers for Transit Research and Management De-

velopment. In addition, conferences on relations between management and labor and training workshops on basic transit cost and performance statistics (Section 15) were initiated. These activities reflect UMTA's response to the growing need for trained personnel and better management tools within the industry. Transit agency attendance at workshops and training programs in safety, planning, management, and the use of microcomputers has grown accordingly.

New FY82 technical assistance projects in the equipment and construction fields focused on developments which will help transit agencies reduce the life-cycle costs associated with owning, using, and maintaining their equipment and facilities. Recurring costs for maintenance, power, fueling, cleaning and other periodic services exact a substantial toll in labor as well as materiel costs. During the lifetime of buses and railcars, maintenance costs generally amount to considerably more than the original costs of acquisition. Based on requests and advice from transit operators, a number of technical assistance projects have been initiated which concentrate on reducing the high cost of maintenance for specific subsystems and components.

The table on technical assistance funding provides a general indication of the proportion of UMTA efforts being expended on several categories of management methods, training and technologies. Most of the projects described in this volume are managed by the Associate Administrator for Technical Assistance and his staff offices. A listing of principal organizational elements in the Office of Technical Assistance is provided in the Staff Directory.

Tables summarizing funding and other information about individual R&D projects follow the descriptive material in each chapter. In these project summary tables, a schedule is listed for each project indicating the time at which the project was approved and the expected completion date. Funding figures are provided to give an indication of the scope of individual tasks, and are generally cumulative. The dollar figures in the tables, therefore, cannot be used for analysis of the FY82 annual budget.

Technical documents describing the results of most of the completed projects have either been issued or are currently in preparation. Published reports are listed in a bibliography following each chapter, and usually may be obtained from the National Technical Information Service (NTIS) of the U.S. Department of Commerce or other sources. Details on how to obtain reports are provided in Appendix A. Forms for ordering publications from NTIS are also included at the end of this document.

Appendix B provides general information for potential contractors and grantees on participation in the UMTA Technical Assistance programs, and includes material on university research grants.

This document was prepared by the Office of Technology Sharing, Transportation Systems Center, U.S. Department of Transportation, Kendall Square, Cambridge, Mass. 02142. Copies may be obtained by contacting that office.

### Technical Assistance Funding (Dollars in thousands)

| Subactivity                                | FY 1982<br>Obligations |
|--|------------------------|
| Bus and Paratransit Systems                | 9,772                  |
| Rail & Construction Technology             | 11,782                 |
| New Technology Development                 | 9,129                  |
| Safety & Security                          | 1,756                  |
| Section 15, Info. & Analysis,<br>and NCTRP | 4,719                  |
| Planning Methods and Support               | 5,866                  |
| Service & Methods                          | 10,279                 |
| Management Techniques                      | 2,988                  |
| Policy Research                            | 2,921                  |
| Management Training (Section 10)           | 1,051                  |
| University Research (Section 11)           | 2,169                  |
| Total                                      | 59,432                 |



## Office of Technical Assistance—Staff Directory

| Organization Code |  | Telephone<br>(Area Code 202) |
|-------------------|--|------------------------------|
| URT-1             | Associate Administrator for Technical Assistance, Peter Benjamin<br>Secretary, Brenda Williams | 426-4052<br>426-4052         |
| URT-5             | Administrative Support Staff, Diane Pisano, Director   | 426-9261                     |
| URT-6             | Safety and Security Staff, Lloyd G. Murphy, Chief  | 426-2896                     |
| URT-2             | Deputy Associate Administrator for Engineering and Applications,<br>Franz K. Gimmler           | 426-4047                     |
| URT-10            | Office of Systems Engineering (Fixed Guideway Programs),<br>Steven Barsony, Director           | 426-0090                     |
| URT-11            | Project Management Division, Walter Kulyk, Chief   | 426-0090                     |
| URT-12            | Design Division, Ronald Kangas, Chief  | 426-9264                     |
| URT-20            | Office of Bus and Paratransit Systems, Tom Norman, Director                                    | 426-4035                     |
| URT-21            | Vehicle Systems Division, Raymon Lopez, Chief  | 426-8483                     |
| URT-22            | Subsystems Technology Division, Vincent DeMarco, Chief   | 426-4035                     |
| URT-3             | Deputy Associate Administrator for Management and Demonstrations,<br>Harold B. Williams        | 426-4047                     |
| URT-7             | Information Services, Ronald Fisher, Director  | 426-9157                     |
| URT-30            | Office of Service and Management Demonstration,<br>W.H. (Ray) Lytle, Director                  | 426-4995                     |
| URT-31            | Transit Services Division, James Bautz, Chief  | 426-4984                     |
| URT-32            | Transit Management Division, Philip Hughes, Chief  | 426-9274                     |
| URT-33            | Research and Training Division, Frank Enty, Chief  | 426-9274                     |
| URT-40            | Office of Methods and Support, Samuel Zimmerman, Director                                      | 426-4991                     |
| URT-41            | Methods Division, Granville Paules, Chief  | 426-9271                     |
| URT-42            | Analysis Division, Ross Adams, Chief   | 426-9267                     |



# Bus and Paratransit Systems

---

## Trends and Highlights



The major goals of the Urban Mass Transportation Administration's (UMTA) Bus and Paratransit Systems program in FY 82 have been to reduce life cycle costs, promote more efficient use of energy, and supply technical assistance to the providers of public transportation.

In FY 82 the UMTA program concentrated on the introduction of new technologies and improved products into transit service through the Bus and Bus Subsystems Technology Program and the New Bus Equipment Introduction (NBEI) Program. The Bus and Bus Subsystems Technology Program is designed to help solve the most serious equipment problems currently being encountered by transit operators. The introduction of new subsystems and components and the improvement of equipment currently available will enhance vehicle reliability and reduce operating and maintenance costs. Added emphasis has been placed on supplying technical assistance to transit operators in the area of developing and validating Life Cycle Cost (LCC) procurement procedures and in developing baseline fuel consumption data for transit vehicles. The NBEI program enables transit operators to evaluate innovative features developed by the private sector. The purpose of this program is to facilitate the introduction of innovative features to the transit industry and make them generally available in a shorter span of time.

In FY 82 the Paratransit Vehicle Program, designed to promote development of special needs transit vehicles, entered the procurement, testing and evaluation phase.

## Bus and Bus Subsystems Technology

The goal of the Bus and Bus Subsystems Technology Program is to develop more efficient, reliable, and easily maintained components and subsystems which will result in lower operating and maintenance costs while simultaneously improving service reliability. Separate projects to improve transmissions, brakes, retarders, air conditioning systems, fare collection systems, passenger counters, and structures (chassis, wall, and roof) have been established. The emphasis of this program is on the development of near-term solutions for day-to-day problems experienced by bus operators.

Three transmission projects are underway at the Michigan DOT (MI-06-0029), Southern California Rapid Transit District (CA-06-0164) and San Diego Transit District (CA-06-0179). These projects will provide an evaluation of improvements which can be retrofitted in buses to reduce maintenance costs.

Tests are being conducted at other transit systems to determine the cost effectiveness of increasing brake lining life by using bonded linings on new and retrofitted buses. Brake retarders are also being tested by the Michigan DOT (MI-06-0025) to establish their effectiveness for increasing brake lining life and reducing maintenance costs. A joint NHTSA/UMTA program to assess the performance of the bus brake anti-lock system (WI-06-0007) encountered technical difficulties which prevented collection of useful data this year.

An air conditioning system which in-

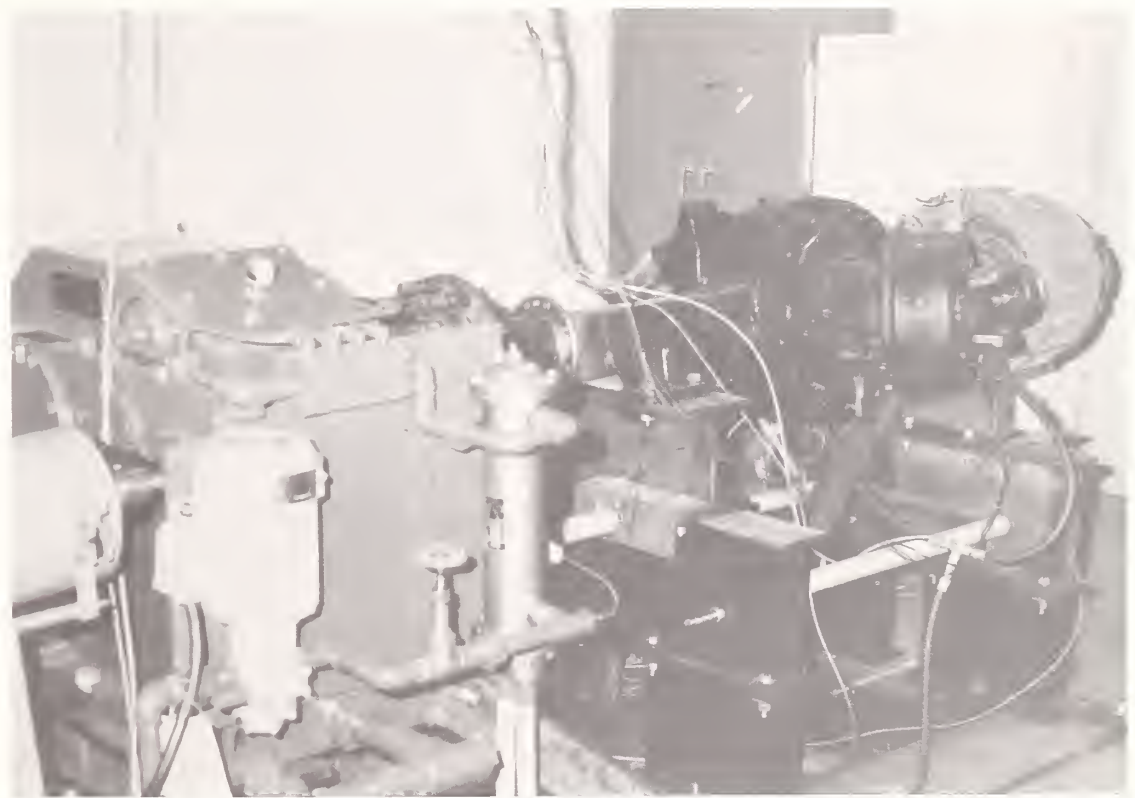

*Dynamometer testing done at the Transportation Systems Center compared the susceptibility of bonded and bolted brake linings to overheating under extreme conditions.*

corporates an improved screw-type compressor is being tested to determine its feasibility (MA-06-0120). Results indicate that this system offers the potential for lower operating and maintenance costs in comparison with conventional compressors.

A project to develop a computer model of a bus structure (IL-06-0051) has been undertaken to afford bus buyers and manufacturers with a common basis for analyzing structural problems.

Another project, conducted jointly by the Environmental Protection Agency and

UMTA, involved Bus Noise Reduction (OR-06-0005). The program demonstrated the effect a well designed bus noise reduction kit has on a representative bus configuration. Retrofit kits for Flxible and GMC "New Look" buses were completed in 1979 and 1982, respectively.

Two projects for the assessment of fare collection systems and of the latest electronic registering fare boxes are currently being performed (MA-06-0120). Rising fares and particularly the increased flow of dollar bills have created major problems in the sorting and counting of





***This rotary screw compressor is being tested on bus air conditioning systems in San Antonio to improve efficiency and lower operating costs.***

fare revenues. These projects will develop recommended solutions for reducing or eliminating fare collection problems.

In a project (MA-06-0060) to assess the operational performance of wheelchair lifts on buses, an initial survey of various systems and sites was completed, and the data collection and evaluation phase was begun. Projects involving the assessment of two innovative small bus configurations were completed by TSC.

Projects to develop and validate Life Cycle Cost (LCC) procurement techniques continued during FY 82. These activities included collecting information on LCC procurement procedures, and cost drivers as well as supporting the test and demonstration of the LCC concept in the acquisition of articulated and small buses by Santa Clara County, Calif. (CA-06-0146).

During FY 1982, a fuel economy test program was initiated. Tests of standard

size, small and articulated buses will be conducted according to an accepted, standardized test procedure. The results will be useful to transit agencies utilizing LCC procurement procedures to purchase new transit buses.

### **Bus Testing Procedures**

Over the past few years, UMTA has become acutely aware of equipment failures in both old and new buses. This has caused considerable downtime and other hardships to transit systems. Many of these problems could have been detected and corrected with adequate testing and evaluation of the hardware prior to delivery. Manufacturers, especially those new to the domestic market, may not perform adequate vehicle testing, and in many cases transit agencies requesting new equipment do not ask for sufficient testing in their bid packages.

The Metropolitan Atlanta (Ga.) Regional Transit Authority (MARTA) has requested that UMTA assist them in developing procedures for accelerated in-service tests and acceptance of their new Neoplan buses. These procedures will be coordinated with other transit agencies and manufacturers through the American Public Transit Association's Bus Technology Liaison Board. MARTA will be responsible for conducting these tests, and procedures developed can be applied by other transit agencies at their discretion (GA-06-0015).

## **New Bus Equipment Introduction (NBEI)**

The NBEI program is intended to provide transit operators an opportunity to

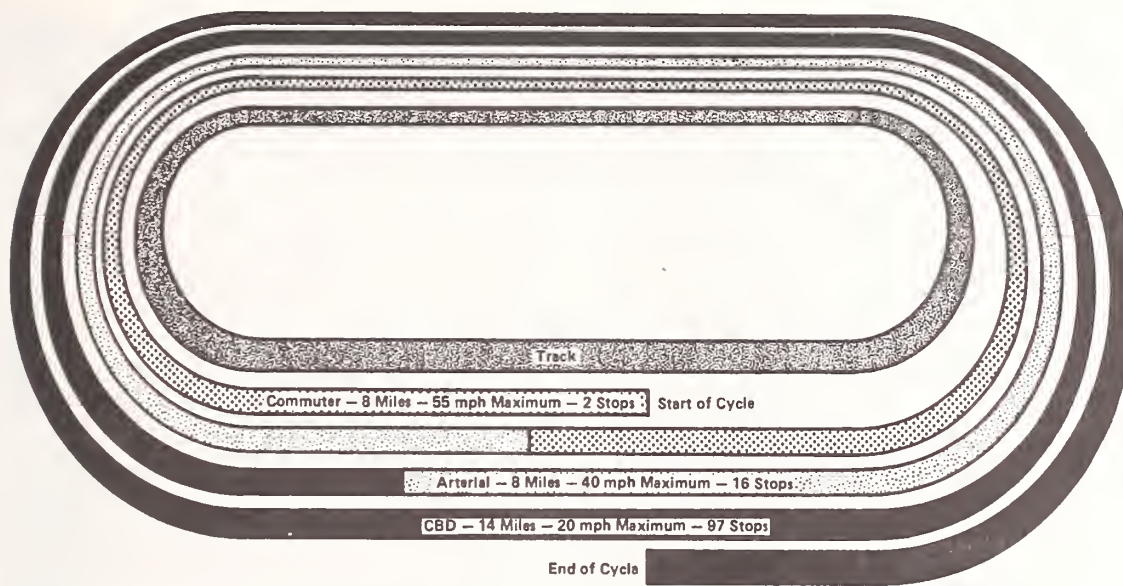

*The bus fuel economy test cycle provides comparative life cycle costs for new vehicle procurements by simulating normal revenue operating conditions.*

select and test various innovative bus design features not currently available in domestic buses. These features have been developed to improve fuel efficiency, reliability and accessibility, and to reduce operating and maintenance costs. In FY 82, UMTA solicited letters of interest from operators and manufacturers regarding what new technologies were needed in transit buses. Section 3 capital grants will be made available to selected transit agencies to purchase buses with innovative features that meet the agencies' specifications. Section 6 grants will then be made available to test and evaluate the buses. When completed, the program will provide the industry with the impetus to develop improved specifications leading to the delivery of better buses financed with federal funds (RI-06-0013, MI-06-0032, OH-06-0040).

## Energy and Propulsion

While the reduction of energy costs for transit is a worthwhile objective, the high level of dependence on petroleum-based fuels is of continuing concern to transit operators. Greater independence from petroleum could be achieved by using alternative fuels or vehicles powered by electricity. Electricity is a major option because, in the United States, only 16 percent of the source energy used in the generation of electricity comes from petroleum.

In support of more efficient diesel propulsion systems, simple calculations indicate that a 10 percent improvement in propulsion system efficiency can save U.S. transit operators in excess of \$40 million per year. UMTA has a three-pronged approach to the transit energy problem:

1) to investigate the increased use of electricity, 2) to examine alternative fuel capabilities in existing bus systems, and 3) to promote more efficient use of petroleum in existing bus systems.

## Electric and Hybrid Propulsion

Development of a Flywheel Energy Storage System (FESS), tests of trolley coach improvements, and evaluations of hybrid buses are the major aims of UMTA's support in the field of electric propulsion.

The FESS program, initiated in 1977, progressed into the hardware development and laboratory testing phase in FY 82. Recently, the nation's trolley coach operators and other transit operators were contacted to assess their interest in the FESS concept. The results were very encouraging. Current plans will permit vehicle testing of a flywheel system on a U.S. transit system by FY 84 (MA-06-0093).

In 1982 the Miami Valley Regional Transit Authority tested a trolley bus equipped with battery emergency power supply system (OH-06-0034). The emergency system permitted the trolley to operate "off wire" for over two miles. A test of a diesel/generator emergency power supply system will be carried out in a MBTA trolley coach in early 1983 (MA-06-0130).

In 1983 the San Francisco Municipal Railway will conduct an evaluation of three types of controllers (cam, dc chopper, ac inductor) in revenue service with a trolley bus (CA-06-0147).

## Alternative Fuels

In the event of future shortages of diesel fuel, UMTA has contracted with the



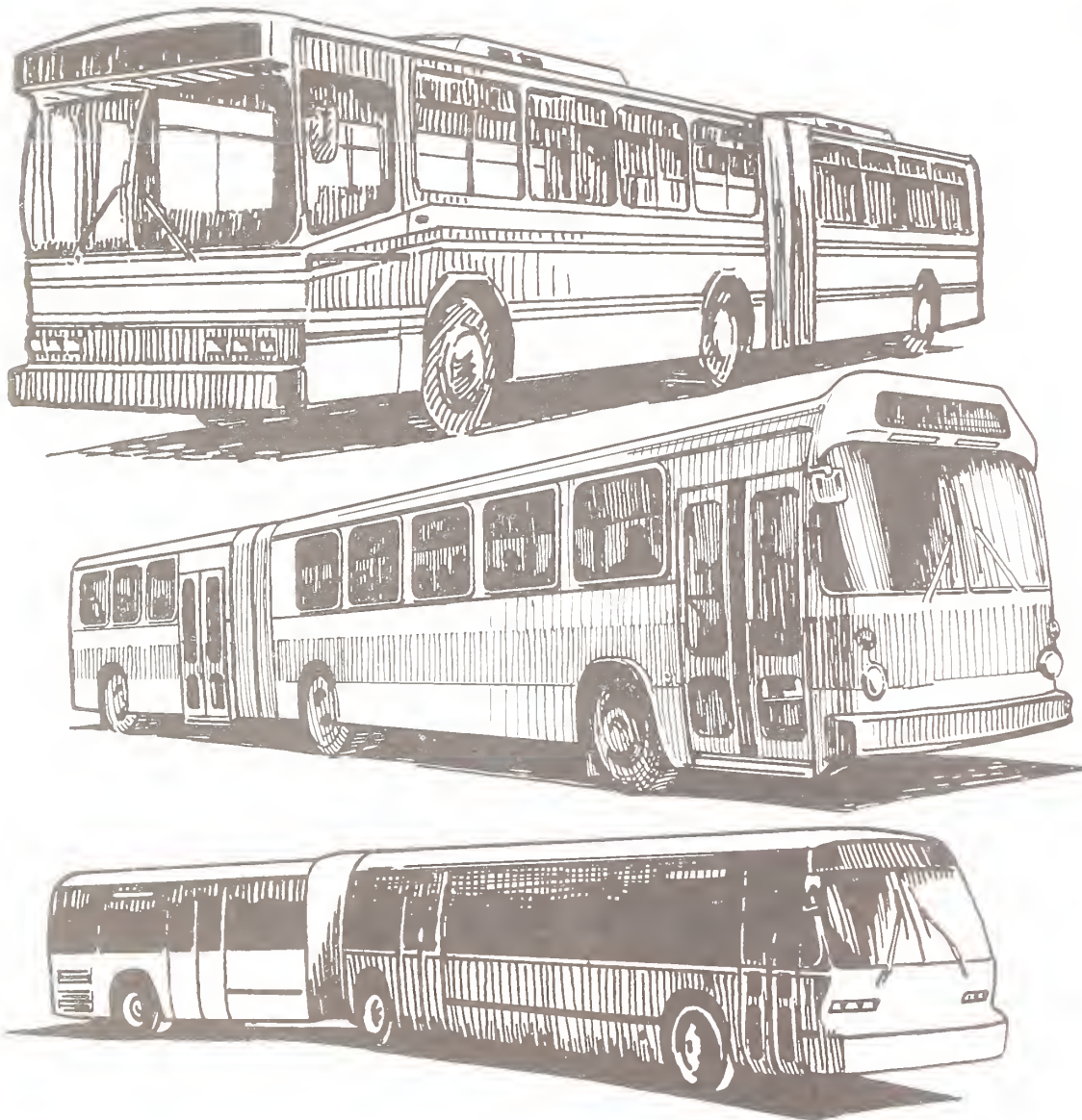

*Through the New Bus Equipment Introduction Program, the Rhode Island Public Transit Authority plans to select and test an innovative articulated bus.*

Port Authority of Allegheny County (PAT), Pittsburgh, Pa., to study the applicability of various alternative fuels to an entire bus transit system (PA-06-0060). It is the intent of the study to identify and recommend a development plan for the most promising fuels, while taking into account availability, operating requirements, cost, and minimum alteration to the current transit infrastructure. The report will be completed in early 1983.

The Florida DOT has recently completed a study (FL-06-0022) which established the feasibility of a methanol modification program for a diesel transit bus. Surface-assisted ignition was determined to be the best means of modification. During FY 83 Florida DOT will modify a DDAD 6V-71 engine for benchtesting on methanol.

## Paratransit Technologies

### Paratransit Vehicle Program

The overall goal of the Paratransit Vehicle Program is to stimulate the automotive industry to manufacture vehicles which meet the needs of paratransit service and to provide these vehicles at an affordable cost. The main objective of the program is to promote the development of vehicles to be used for a wide range of paratransit services, such as shared-ride taxicab service, dial-a-ride, transportation for the elderly and handicapped, and other transportation services that do not require the capacity of vans or small buses.

PAT will purchase, test and evaluate an innovative paratransit vehicle in revenue service. Data will be collected and





analyzed, and disseminated to the para-transit industry for use in making future manufacturing and purchasing decisions (PA-06-0064).

*Renewed interest in the trolley bus and trolley bus hybrids was evidenced by participants at the UMTA and TRB-sponsored workshop on Trolley Bus Applications.*



*The UMTA-sponsored Small Transit Vehicle Conference at Fort Worth was an opportunity for the transit industry to exchange ideas and facilitate communications between suppliers, operators, and government officials.*

## Bus and Paratransit Systems

| PROJECT TITLE   | NUMBER     | FUNDING                                  | SCHEDULE                  | AGENCY/<br>CONTRACTOR                                     | TECHNICAL<br>CONTACT                  |
|---|------------|--|---------------------------|---|---------------------------------------|
| <b>BUS AND BUS SUBSYSTEMS TECHNOLOGY</b>                      |            |  |                           |   |                                       |
| Transmission Test and Evaluation                              | MI-06-0029 | \$280,000                                | Aug. 1981-<br>Oct. 1983   | Michigan DOT  | Steve Asatoorian<br>(202) 426-4035    |
| GFC 870 Air Conditioning Retrofit Evaluation                  | GA-06-0016 | \$96,000                                 | Sept. 1981-<br>Sept. 1983 | MARTA   | George Izumi<br>(202) 426-4035        |
| Test of Improved Components and Subsystems on AMG & RTS Buses | CA-06-0164 | \$372,000                                | Sept. 1981-<br>March 1983 | SCRTD   | Steve Asatoorian<br>(202) 426-4035    |
| Transmission Test and Evaluation                              | CA-06-0179 | \$141,000                                | July 1982-<br>Aug. 1983   | San Diego Transit Corp.                                   | Steve Asatoorian<br>(202) 426-4035    |
| Evaluation of Bus Retarders                                   | MI-06-0025 | \$292,000                                | Aug. 1981-<br>April 1983  | Michigan DOT  | Steve Asatoorian<br>(202) 426-4035    |
| Bus Brake Anti-lock Assessment                                | WI-06-0007 | \$62,000                                 | Nov. 1979-<br>June 1983   | Milwaukee County Transit Authority                        | Steve Asatoorian<br>(202) 426-4035    |
| Rotary Screw Air Conditioning System Evaluation               | MA-06-0120 | \$455,000                                | Aug. 1981-<br>Jan. 1983   | TSC; Garrett AiResearch                                   | George Izumi<br>(202) 426-4036        |
| Structural Analysis   | IL-06-0051 | \$240,000                                | March 1981-<br>March 1982 | Northern Illinois RTA                                     | Denis Symes<br>(202) 426-8483         |
| Bus Noise Reduction   | OR-06-0005 | \$155,000<br>(UMTA)<br>\$65,000<br>(EPA) | July 1978-<br>Feb. 1983   | TRIMET  | Patrick J. Sullivan<br>(202) 426-4035 |
| Electronic Registering Farebox Assessment                     | MA-06-0120 | \$55,000                                 | Jan. 1983-<br>Sept. 1983  | TSC; Booz, Allen and Hamilton, Inc.                       | George Izumi<br>(202) 426-4035        |
| Fare Collection Assessment                                    | MA-06-0120 | \$125,000                                | Dec. 1982-<br>Dec. 1983   | TSC; Dynatrend  | George Izumi<br>(202) 426-4035        |
| Farebox Modification Evaluation                               | NY-06-0093 | \$35,700                                 | July 1982<br>Aug. 1983    | Metro Suburban Bus Authority                              | George Izumi<br>(202) 426-4035        |
| Life Cycle Costing  | CA-06-0146 | \$300,000                                | July 1980-<br>June 1985   | Santa Clara County (Calif.) Transportation Administration | Denis Symes<br>(202) 426-8483         |
| Automatic Bus Lubrication                                     | NY-06-0091 | \$37,600                                 | Jan. 1982-<br>June 1984   | NFTA, Buffalo, NY.  | George Izumi<br>(202) 426-4035        |

## Bus and Paratransit Systems

| PROJECT TITLE  | NUMBER     | FUNDING      | SCHEDULE                 | AGENCY/<br>CONTRACTOR                 | TECHNICAL<br>CONTACT                  |
|--|------------|--------------|--------------------------|---------------------------------------|---------------------------------------|
| <b>BUS AND BUS SUBSYSTEMS TECHNOLOGY (CONT.)</b>             |            |              |                          |                                       |                                       |
| Evaporative Cooler Evaluation                                | CO-06-0012 | \$240,000    | March 1982-<br>Feb. 1983 | Denver RTD                            | George Izumi<br>(202) 426-4035        |
| Rear Tow Hoist for ADB Buses                                 | NY-06-0093 | \$28,700     | July 1982-<br>Aug. 1983  | Metro Suburban Bus Authority          | George Izumi<br>(202) 426-4035        |
| Automated Maintenance Data Collection Study                  | VA-06-0093 | \$115,000    | Jan. 1983-<br>March 1984 | Technology Research Analysis Corp.    | George Izumi<br>(202) 426-4035        |
| AM General Roof-Mounted Air Conditioning Retrofit Evaluation | NY-06-0094 | \$325,000    | May 1982-<br>Sept. 1983  | Central New York RTA                  | George Izumi<br>(202) 426-4035        |
| ADB Operating and Maintenance Monitoring                     | DC-06-0364 | \$50,000     | Sept. 1981-<br>Oct. 1982 | APTA                                  | Thomas Norman<br>(202) 426-4035       |
| Engine Testing Program for Standard Size Buses               | MI-06-0037 | \$192,000    | Oct. 1982-<br>Oct. 1984  | Michigan DOT                          | Steve Asatoorian<br>(202) 426-4035    |
| Bus Testing Procedures                                       | GA-06-0015 | \$150,000    | Sept. 1981-<br>Dec. 1982 | MARTA                                 | John E. Ridgley<br>(202) 426-8483     |
| <b>NEW BUS EQUIPMENT INTRODUCTION PROGRAM</b>                |            |              |                          |                                       |                                       |
| New Bus Equipment Introduction Program                       | RI-06-0013 | \$100,000    | June 1982-<br>June 1984  | Rhode Island Public Transit Authority | John E. Ridgley<br>(202) 426-8483     |
| New Bus Equipment Introduction Program                       | MI-06-0032 | \$106,000    | June 1982-<br>June 1984  | Michigan DOT                          | John E. Ridgley<br>(202) 426-8483     |
| New Bus Equipment Introduction Program                       | OH-06-0040 | \$100,000    | June 1982-<br>June 1984  | Central Ohio Transit Authority        | John E. Ridgley<br>(202) 426-8483     |
| <b>ENERGY AND PROPULSION</b>                                 |            |              |                          |                                       |                                       |
| Flywheel Energy Storage                                      | MA-06-0093 | \$15,000,000 | Dec. 1978-<br>Dec. 1984  | TSC                                   | Steve Asatoorian<br>(202) 426-4035    |
| Emergency Propulsion System for Trolley Coaches              | OH-06-0034 | \$40,000     | Dec. 1981-<br>Dec. 1982  | Miami Valley (Ohio) RTA               | Patrick J. Sullivan<br>(202) 426-4035 |



## Bus and Paratransit Systems

| PROJECT TITLE  | NUMBER                   | FUNDING                                       | SCHEDULE                               | AGENCY/<br>CONTRACTOR                                   | TECHNICAL<br>CONTACT                  |
|--|--------------------------|---|--|---|---------------------------------------|
| <b>ENERGY AND PROPULSION (CONT.)</b>                     |                          |   |  |   |                                       |
| Emergency Propulsion System for Trolley Coaches          | MA-06-0130               | \$77,000                                      | Dec. 1981-<br>April 1983               | MBTA  | Patrick J. Sullivan<br>(202) 426-4035 |
| Comparative Trolley Bus Controller Project               | CA-06-0147               | \$661,000                                     | Jan. 1981-<br>Aug. 1983                | MUNI  | Patrick J. Sullivan<br>(202) 426-4035 |
| Alternative Fuels Study for Urban Mass Transit Buses     | PA-06-0060               | \$125,000                                     | Oct. 1980-<br>July 1982                | PAT   | Patrick J. Sullivan<br>(202) 426-4035 |
| Use of Methanol as an Alternative Fuel for Transit Buses | FL-06-0022               | \$3,000,000<br>(Estimated)                    | Oct. 1980-<br>Aug. 1983<br>(Projected) | Florida DOT   | Patrick J. Sullivan<br>(202) 426-4035 |
| Gas Turbine Urban Bus                                    | DC-06-0204<br>MD-06-0059 | \$2,800,000<br>(DOT)<br>\$11,200,000<br>(DOE) | May 1978-<br>Dec. 1981                 | MTA, Baltimore, Md.                                     | Thomas Norman<br>(202) 426-4035       |
| Santa Barbara Electric Vehicle Project                   | CA-06-0177               | \$3,000,000                                   | Aug. 1982-<br>March 1985               | Santa Barbara (Calif.)<br>Metropolitan Transit District | Patrick J. Sullivan<br>(202) 426-4035 |
| Bi-Mode Trolley Bus Demonstration                        | WA-06-0020               | \$227,525                                     | Dec. 1981-<br>June 1983                | Seattle (Wash.)<br>Metro                                | John E. Ridgley<br>(202) 426-8483     |
| Stored Hydraulic Energy                                  | OR-06-0007               | \$1,000,000                                   | Oct. 1980-<br>May 1983                 | TRIMET  | Patrick J. Sullivan<br>(202) 426-4035 |
| <b>PARATRANSIT TECHNOLOGIES</b>                          |                          |   |  |   |                                       |
| Paratransit Vehicle Deployment Evaluation                | PA-06-0064               | \$682,000                                     | Sept. 1981-<br>June 1984               | PAT   | John E. Ridgley<br>(202) 426-8483     |
| Paratransit Vehicle Technical Support                    | IT-06-0272               | \$170,000                                     | Dec. 1981-<br>July 1984                | Dynatrend, Inc.   | John E. Ridgley<br>(202) 426-8483     |



## Bibliography

A list of recent reports follows. Please consult previous editions of this Directory for earlier reports. If available, a document number assigned by the National Technical Information Service (NTIS) is listed. Reports may be obtained from NTIS by using the order blanks provided at the end of this document.

Reports which have not been assigned an NTIS number may not have been published in sufficient quantity for general distribution. Single copies and other information may be available from the issuing agency or organization.

Additional reports relating to the research described in this chapter may become available in the near future. For the most recent information or suggestions for additional reference materials regarding specific projects, call or write to the person listed as the technical contact in the Project Summary Table.

Local public agencies may obtain a single copy of those reports marked by an asterisk (\*)—while supplies last—by sending a self-addressed mailing label to: Office of Technology Sharing, DTS-31, U.S. Department of Transportation, Transportation Systems Center, Kendall Square, Cambridge, MA 02142. Please specify which reports are needed and please request only those titles which are expected to be used in the near future.

### **Advanced Bus Air Conditioning System**

Proj. CA-06-0145

AiResearch Manufacturing Company of California

June 1980, PB 80-215-502

### **\*Air Conditioning Modifications for GMC RTS II Series 01 Coach (Model 8201)**

Proj. MA-06-0120

Transportation Systems Center  
March 1982

### **Advanced Design Bus Ventilation Testing**

Proj. MD-06-0024

Booz, Allen and Hamilton, Inc.  
March 1981, PB 81-182-446

### **\*Reliability Evaluation of V-730 Transmission**

Proj. MA-06-0120

Transportation Systems Center  
May 1982 (reprint),  
DOT-TSC-UM 262-PM-82-13

### **\*Bill Handling Problems in Bus Fare Collection**

Proj. MA-06-0120

Transportation Systems Center  
October 1982, DOT-TSC-UMTA-82-43

### **\*Bus Transit Fare Collection Equipment Overview**

Proj. MA-06-0120

Transportation Systems Center  
May 1982, DOT-TSC-UMTA-82-9

### **Ramp Design Parameters for Low-Floor Transit Buses**

Proj. MD-06-0024

Booz, Allen and Hamilton, Inc.  
April 1980, PB 81-151-342

### **Body Corrosion in Transit Buses**

Proj. MD-06-0024

Booz, Allen and Hamilton Inc.  
November 1980, PB 80-196-546

### **Life Cycle Cost Procurement Procedures for Advanced Design Buses: Development and Test Application**

Proj. VA-06-0045

Advanced Management Systems  
May 1980, PB 80-209-026

### **\*Technology of Articulated Transit Buses**

Proj. MA-06-0120

Transportation Systems Center

May 1982 (reprint), DOT-TSC-UM  
262-PM-82-14

### **\*Entry and Competition in the United States Transit Bus Manufacturing Industry**

Proj. MA-06-0120

Transportation Systems Center  
October 1982, UMTA-MA-06-0120-82-2

### **\*Transit Bus Manufacturers Profile**

Proj. MA-06-0120

Transportation Systems Center  
May 1982 (reprint),  
DOT-TSC-UM 262-PM-82-13

### **\*Preliminary Evaluation of the Scania 112 Bus: The First Three Months at Norwalk Transit District**

Proj. MA-06-0120

Transportation Systems Center  
January 1982,  
DOT-TSC-UM 262-PM-82-17

### **\*Highlights of the Transit Bus Technology Workshop, April 29-30, 1982**

Proj. MA-06-0120

Transportation Systems Center  
September 1982, DOT-TSC-UMTA-82-38

### **New Bus Equipment Introduction Program Test and Evaluation Plan**

Proj. MD-06-0063

Acumenics  
March 1981

### **Study of Flywheel Energy Storage, Vols. I-V.**

Proj. CA-06-0106

L. J. Lawson, A. K. Smith, and G. D. Davis; Garrett AiResearch  
1977, PB 282-652

### **Trolley Bus Auxiliary Power Unit Feasibility Test and Demonstration**

Proj. OH-06-0034

AiResearch Manufacturing Company  
September 1982

### **Investigation of the Applicability of a Stored Hydraulic Energy Propulsion**

**System to a Conventional Bus**

Proj. OR-06-0007

Booz, Allen and Hamilton, Inc.

August 1981

**Transit Bus Fuel Economy Test**

Proj. DOT-TSC-1744

Booz, Allen and Hamilton, Inc.

April 1981

**\*Evaluation of Alternative Fuels for Urban Mass Transit Buses**

Proj. PA-06-0060

Booz, Allen and Hamilton, Inc.

February 1983

**Equipment and Maintenance Requirements for Light-Weight Accessible Bus Operations**

Proj. MA-06-0060

Transportation Systems Center

June 1980, UMTA-MA-06-0060

**Evaluation and Assessment of Wheelchair Lifts on Public Transit Buses**

**Phase 1 Report**

Proj. MA-06-0060

Transportation Systems Center

May 1981, DOT-TSC-UM229-PM-81-54

**\*Wheelchair Lifts of Transit Buses**

Proj. MA-06-0120

Kentron Inc.

January 1983, DOT-TSC-UMTA-83-2

**Crash Protection Systems for Handicapped School and Transit Bus Occupants**

**Vol. I, Executive Summary**

**Vol. II, Technical Report**

**Vol. III, Appendices A, B, C, and D**

**Vol. IV, Appendix E**

**Vol. V, Appendices F and G**

Proj. DC-06-0200

Minicars, Inc., for a joint study

sponsored by UMTA and NHTSA

December 1980, DOT-HS-805-822

**Wheelchair Securement on Bus and Paratransit Vehicles**

Proj. CA-06-0098

California Department of Transportation

April 1981, UMTA-CA-06-0098-81-1

**Safety Guidelines for Wheelchair Lifts on Public Transit Vehicles**

Proj. CA-06-0098

California Department of Transportation

July 1980, PB 81-104-655

**Loran-C RFI Measured in Los Angeles, Calif.**

Proj. MA-06-0041

Systems Control, Inc.

October 1980, PB 81-151-300

**\*Small Transit Vehicles Conference Summary**

Proj. MA-06-0120

Dynatrend, Inc.

October 1982, DOT-TSC-UMTA-82-44

**\*Program Factsheets (4-8 pp.):**

**Advanced Area Coverage Automatic Vehicle**

**Monitoring Program, July 1980**

**Alternative Fuels for Diesel Buses, December 1981**

**Bus Subsystems Technology Program, October 1981**

**Flywheel Energy Storage System Program for Urban Transit Motor Vehicles, June 1981**

**Paratransit Vehicle Program, May 1982**

Proj. MA-06-0086

Transportation Systems Center

# Rail and Construction Technology

---

## Trends and Highlights



**B**udgetary constraints and rising costs make it imperative for transit operators to increase productivity, make better use of existing capital intensive facilities, and improve design, engineering and construction techniques. Research and development efforts under the current Rail and Construction Technology Program provide a substantial foundation for achieving these goals in the 1980's. The nature of rail transit requires that attention be focused primarily on basic technical problems encountered in normal operations. The objective of the UMTA program is to devise short-term solutions for these problems.

The program seeks to promote the following benefits for operators and passengers of urban rail transportation systems: 1) lower initial and life-cycle operating costs for rail vehicles and facilities; 2) improvements in the reliability, maintainability and availability of vehicles and systems; 3) improved operations, and 4) a safer environment for passengers and system personnel.

The program is organized into four elements: requirements analysis, and evaluation; system integration and deployment; vehicle and equipment technology; and construction technology.

## Requirements Analysis, and Evaluation

This aspect of the UMTA program seeks to achieve the following goals: 1) reduced life-cycle costs; 2) improved performance, reliability, maintainability, safety and energy conservation, and 3) improved maintenance practices and procedures. It



provides a link between the practical experience and problems of urban rail systems and the R&D required to improve these systems. The urban rail transit market is continually evaluated from the standpoint of supply and demand in order to maximize the impact of R&D efforts.

Railcar and rail system maintenance is the major focus of this program area. Maintenance activities, rail and nonrail, consume about 40% of the operating expenditures of 12 rail transit operating budgets. Maintenance expenditures have been increasing by approximately 10% a year since 1975, with an increasing rate in recent years. These facts make maintenance a prime candidate for UMTA research and development activities in support of the transit community.

Maintenance related projects are found in most parts of the Rail and Construction Technology program. Current ongoing projects with promising short and long term cost/benefit ratios include studies of wheel/rail wear, air comfort systems and tunnel water intrusion. The Transit Reliability Information Program (TRIP) is also included under this program category. TRIP is a cooperative effort among transit operators, suppliers, APTA and a consultant to gather and analyze subsystem reliability information on six rail transit systems. Dr. Richard Uher of Carnegie-Mellon University completed an in-depth review of the TRIP project, and found that it had met its original objectives relating to gathering and processing uniform equipment reliability data on railcar systems. The data bank is no longer considered experimental, and processed information is being made available to the public. TRIP will continue to provide information necessary for determining subsystems and

minimum subsystem performance levels in new car purchases.

In addition, a major effort has been initiated to assist transit operators in improving or developing management information systems (MIS) consistent with generic industry guidelines. Projects are being undertaken with several transit systems to make existing management information systems more efficient, with the aim of improving maintenance productivity.

## Systems Integration and Deployment

The Systems Integration and Deployment Program is directed toward concurrently achieving cost reductions, and improved safety, noise abatement, and accessibility for the elderly and handicapped. The program consists of the following elements: 1) standardization; 2) accessibility for the elderly and handicapped; 3) urban rail noise abatement; 4) new construction and improvements in operations of the Transportation Test Center (TTC) at Pueblo, Colo., and 5) wheel/rail dynamics. Standardization is necessary because of rapidly escalating new railcar and rail system costs, coupled with decreased reliability of newly delivered equipment. The program to promote accessibility for the elderly and handicapped is in response to recent Congressional policy decisions. Noise abatement is necessary to maintain ridership and to permit normal community activities in the vicinity of urban rail transit systems at minimum costs. The TTC provides a place where vehicles can be tested in a safe and controlled situation. The wheel/rail dynamics

program is designed to point up interactive relationships between vehicle and track systems in order to increase safety and to reduce wheel and track wear, energy consumption, and noise.

### Standardization

The rail transit equipment industry historically has produced customized equipment for individual operators, resulting in a proliferation of designs. This approach contrasts with that of locomotive and bus manufacturers, who offer a small number of vehicle designs and performance variations and whose vehicles share common components. The designs of locomotive and bus manufacturers also benefit from the fact that the product lines can be improved in an evolutionary manner.

During the last decade, the U.S. transit railcar market has been characterized by uncertainty and instability. The cost of railcars has risen considerably. Many older railcar manufacturers, and a number of more recently established ones, have incurred large losses and ceased passenger car production. Railcars have become more complex as well as less reliable. Buyers and suppliers frequently resort to litigation to resolve their disputes.

The constituencies involved have debated the problems of the railcar market, but have failed to reach agreement. No single approach can assure a stable market because the basic issues are interwoven with all aspects of the rail transit industry — procurement practices, maintenance, training, product improvement, product innovation, management planning, financial constraints, etc. However, standardization of specifications, components

and performance requirements, as well as of contractual terms and conditions, could bring important benefits to all sectors of the rail transit industry. UMTA has therefore been working with operators, suppliers and consultants to develop and refine railcar specifications and contractual models. In addition, data on subsystem performance is being systematically gathered and analyzed under the TRIP program.

In 1976, UMTA began a two-phase project on rapid railcar standardization (IT-06-0175, IT-06-0229, MA-06-0025 and DC-06-0121). The first phase involved a study of the feasibility of standardization. The second phase, now completed, was primarily concerned with the development of a standardized, or baseline, rapid transit car specification. Subtasks in the project included a study of car body materials, a service-evaluated products list, uniform acceptance test procedures, a Life Cycle Cost selection methodology for propulsion systems, and preliminary subsystem interface standards. The Standardization Committee of the Railway Progress Institute, representing the supply industry, has actively cooperated in all phases of the project.

Recent special studies included a quantitative analysis of the benefits of continuing the standardization program. A study of rail car contractual provisions documents one of the most contentious areas of railcar contracts. This report presents a warranty model and screen for developing warranty/reliability contractual provisions. The problem of standardization remains of strong concern to both operators and suppliers as costs of new railcars and spare parts continue to escalate.



***Recent studies show that dollars spent on standardization of specifications, contract terms, testing, components, and materials are a good investment for both buyers and manufacturers.***

In 1972, a group of transit operators, aided by consultants, developed specifications for a new light rail vehicle (LRV). Because of concern about the high bid price of recently ordered LRV's, and because of the high operating costs of LRV's recently put in service by the Massachusetts Bay Transportation Authority (MBTA), Boston, Mass., and the San Francisco Municipal Railway (MUNI), an UMTA consultant crit-

ically reviewed the specifications in order to recommend ways of reducing costs without adversely affecting performance. A final report has been issued on this study (MA-06-0025), and the LRV specifications have been revised to incorporate the results of this study as well as a number of other changes (e.g., four- or six-axle options). The revised specifications, detailed in the *Light Rail Transit Car Spec-*



ification Guide (MA06-0025-81), were prepared in 1981 through the Transportation Systems Center (TSC) in cooperation with the transit industry.

In related projects (DC-06-0186 and IT-06-0271), a Rail Transit Design Digest is being developed. This document will assist UMTA, transit planners, engineers and other transit professionals in developing new rapid rail transit systems or in expanding and modernizing existing systems. The Digest will address the issues of construction planning, safety, environmental acceptability, aesthetics, cost ef-



**This pre-revenue service test of a wheel-chair lift at MUNI resulted from an UMTA-sponsored study on the feasibility of lift retrofits.**

fectiveness, operating efficiency, maintainability, reliability, accessibility and standardization of system elements.

The project involves detailed analysis of industry practices and of various standards, guidelines, codes, regulations and other documents used by the industry for the planning, design, construction and operation of urban rail transit systems. From this material a summary will be compiled of industry recommended design and operational practices in such areas as railcar power, equipment, signals and communication; ways and structures; yards and shops; safety, and emergency equipment. Preliminary and final design phases of construction will also be discussed.

A detailed outline for the scope and content of the Digest was developed by the American Public Transit Association (APTA) in the first phase of the project. UMTA has selected a contractor to develop the Digest itself in the second phase (IT-06-0271). APTA and other organizations will assist UMTA in reviewing in draft form the technical material produced.

### **Elderly and Handicapped Rail System Accessibility**

The Elderly and Handicapped Rail System Accessibility Program has focused on two major areas: rail vehicle lifts and the railcar/station platform interface. A detailed lift feasibility study (MA-06-0025) resulted in a comprehensive report, *The Feasibility of Retrofitting Lifts on Commuter and Light Rail Vehicles*. This report details which types of railcars are suitable for lift retrofit. A contract has been awarded for a lift retrofit on a Boeing LRV after preliminary analysis and design. A San Francisco Municipal Railway (MUNI) LRV with a retrofitted lift is currently being tested in

an operating environment (CA-06-0185). A test report and lift specifications will be prepared at the conclusion of the project.

Additional related work has been conducted by the Rehabilitation Center of the Veterans Administration to document the ability of wheelchair users to traverse various horizontal and vertical gaps commonly found in high platform rapid rail systems. The study (MA-06-0025) was engendered by the potential high cost of gap filler device installation as hypothesized in a rapid rail system accessibility cost study mandated by the Congress. The Veterans Administration study found that experienced wheelchair users can successfully cope with the moderate gaps common to many transit systems.

The Veterans Administration study was incorporated into a comprehensive analysis of the railcar/station platform gap problem. It was found that there are no universally accepted industry gap standards. New rail transit systems have minimal permissible gaps to allow for the dynamic movement of a train through a station. Existing mechanical gap fillers are in special use on one transit system, but are not considered to be universally applicable due to a variety of operational and cost problems.

In other studies, baseline information by handicap category (deafness, blindness, etc.) is being obtained in order to establish specific requirements for the solution of difficulties encountered by people in each category of handicap.

During FY 81, a study by the Boston College School of Special Education to develop procedures for improving communication with the visually impaired in rapid rail transit systems (MA-11-0036) was completed.

## Noise Abatement Technology

The purpose of the Urban Rail Noise Abatement Program is to reduce the environmental impact of noise caused by existing transit systems, and to reduce the cost of noise control through the development and deployment of new and improved data methods and hardware. This program is planned and conducted at TSC under the sponsorship and direction of UMTA.

A previous TSC effort (MA-06-0025) resulted in the development of a national assessment of urban rail noise. This document summarized and compared the noise levels to which transit patrons and community residents were exposed by rapid rail operations in the United States. Another previous effort involved the in-service testing of four noise abatement techniques — resilient wheels, ringdamped wheels, wheel truing and rail grinding — on the Southeastern Pennsylvania Transportation Authority (SEPTA). An in-service test (MA-06-0099) is being conducted on NYCTA to further evaluate damped wheel treatments for noise abatement. These include the 'Krupp' tuned damper, the 'Sumitamo' double-ring damper, a constrained layer technique, and a combined ring damper and constrained layer design. These tests will develop data on long-term costs and performance.

Previous UMTA research investigated how wheel and rail interact to produce noise and vibration. A current research effort (MA-06-0099) uses this knowledge to improve the effectiveness of wheel/rail noise abatement techniques. Previously developed mathematical models have been refined on the basis of new data and new field tests. The field tests were per-

formed at the Pullman Standard test track near Denver, Colo., the TTC test track, and on several transit systems including the NYCTA, MBTA and CTA.

For selected wheel/rail noise abatement treatments, the improved models were used to predict which possible design changes would produce maximum reductions in noise levels. One application of the model was the design and manufacture of a resilient treaded wheel, for which testing is planned. Other treatments evaluated in this study were wheel truing, wheel flat prevention, rail grinding, hardfaced rail, and rail lubrication.

A significant finding of the SEPTA study was that the propulsion system is a major source of noise at higher operating speeds. UMTA is sponsoring research on propulsion system noise—its causes and possible solutions (MA-06-0099). A survey of existing propulsion units has been conducted. Propulsion subsystems from NYCTA and WMATA will be tested and evaluated.

Urban rail elevated structures have a greater environmental noise impact than any other part of an urban rail system. A project is underway to assess this impact and design ways to control it (MA-06-0025). A survey of elevated structures in the United States has been completed, and an analytical model has been developed to predict the degrees of noise in elevated structures. Based on this work, design guidelines for the control of noise from existing structures have been developed. Design concepts for a resilient fastener, optimized to reduce noise from an elevated structure, are being developed.

UMTA and TSC were invited by WMATA to help solve the problem of excessive squeal noise from brake systems.

A two-part program was initiated to reduce brake squeal. The short-term approach was to try different combinations of brake pads, discs, and calipers on railcars until the quietest combination was found. By April 1981, noise levels were reduced from 100 to 80 decibels through the use of modified pads. The lower level of noise was acceptable, but brake pad and rotor wear were excessive.

A long-range solution to this problem at WMATA and all other U.S. rail transit systems will require the development of universal design guidelines for brake systems that are quiet, nonpolluting (asbestos-free), economical and safe. As a first step in developing these guidelines, UMTA is sponsoring research to determine the causes of brake squeal and find ways to predict and mitigate the noise.

Groundborne noise and vibration from transit tunnels are other sources of community disturbance. Research is being carried out to find ways to ameliorate this problem (MA-06-0099). Different technologies for controlling groundborne noise and vibration in the United States and Europe have been surveyed and evaluated. The techniques studied include floating slab trackbed, truck design parameters, ballast mats, trenches, and resilient fasteners. A model developed to predict groundborne vibrations for track types, tunnel structures, surrounding earth and building structures has been successfully applied at Baltimore and Los Angeles. Using this prediction model, design modifications will be made to optimize vibration control. The safety of the techniques, as well as installation and maintenance costs, will also be assessed. Finally, recommendations for in-service testing of the selected techniques will be made, and fur-



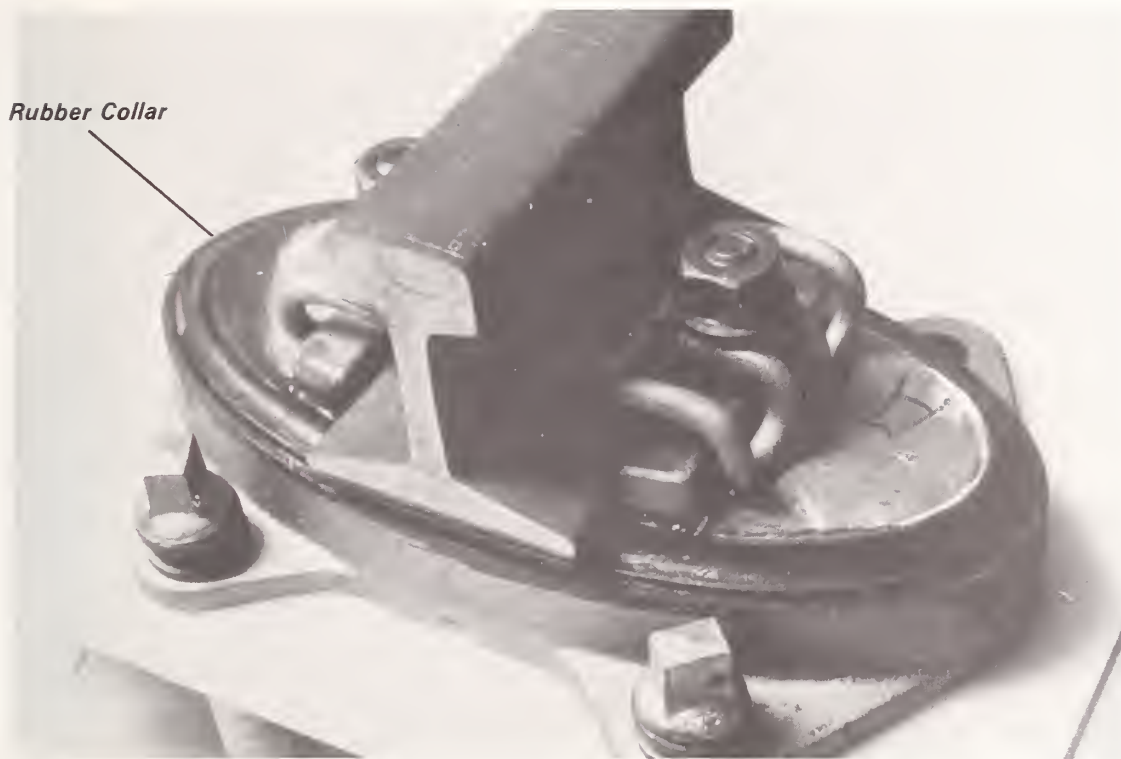

***The Cologne Egg, an innovative resilient track fastener, has a vulcanized rubber collar sandwiched between two metal plates to reduce the amount of vibration from rail to trackbed and nearby buildings.***

ther vibration tests and model refinements will be performed.

To assist engineers in the selection and application of noise control techniques, a computer program—PEACE—has been developed by TSC (MA-06-0099). NYCTA assisted in the creation of the program by providing application criteria and noise data. The first application of PEACE is being performed by NYCTA on an in-house computer.

An Urban Rail Noise Abatement Information Center has been established at TSC. Information on urban rail noise

abatement has been collected from a variety of sources and is available to all who wish to use it.

UMTA is concerned with the implementation of noise control technology as well as with its development. The profusion of recent literature makes it difficult for transit authorities to select and implement technology for noise and vibration control. *A Handbook of Urban Rail Noise and Vibration Control* (MA-06-0099) has been developed to summarize this literature in a form that can be used by transit authorities, suppliers and consultants. The

topics covered include: 1) fundamentals of sound and vibration; 2) measurement techniques; 3) acceptability criteria; 4) noise control actions required for new and old systems, and 5) techniques recommended for control of vehicle, station, wayside, elevated structure, and groundborne noise and vibration.

In addition to the handbook, a *Compendium of Acoustical Materials* (MA-06-0099) serves as an aid to rail transit operators in the implementation of noise control. The compendium provides an index of suppliers of materials, products, and services related to noise control and noise measurement.

### **Comprehensive Testing**

The Transportation Test Center (TTC), a DOT facility operating under management of the Federal Railroad Administration (FRA), is an intermodal center for testing, evaluation and development of ground transportation systems and their components. The testing is performed by DOT organizations, other government agencies, and private industry. On October 1, 1982, management of the facility will be assumed by the Association of American Railroads (AAR).

The urban rail test facilities at TTC (CO-06-0009) consist of a 9.1 mile, oval, electrified rail transit test track, a power system for energizing the track, and repair, maintenance and support facilities. The rail transit test track is designed for the testing and evaluation of urban railcars—light, rapid and commuter. A second purpose of the track is the development, testing and evaluation of state-of-the-art track structures.

In addition to the conventional contact rail electrification, approximately two miles



of simple overhead catenary has been constructed over part of the track to permit testing and evaluation of urban railcars that use overhead power collection systems.

The installation of a permanent solid-state power station to supply electricity to the transit test track has been completed. Two substations and a software control unit give the system the ability to automatically maintain desired third rail voltage levels at the vehicle, and to receive power regenerated from the vehicle. The system became operational with automatic control in FY 81.

The power station was first utilized in a fault clearing test on railcars used by the Metropolitan Atlanta Rail Transit Authority (MARTA), Atlanta, Ga. A surge of voltage was applied, and the operation of protective devices such as circuit breakers was observed.

The Rail Dynamics Laboratory is also located at TTC. It is designed to simulate rail dynamics for the purpose of studying the periodic and random oscillations of rail vehicles.

Recently, a tight-turn loop was completed at TTC. This is a 150-foot radius curve track which has enabled researchers to validate wheel/rail noise phenomena using the State-Of-The-Art vehicle.

The Urban Rail Building is another special facility at TTC. It is located within the transit test track oval and provides 20,000 square feet for vehicle service facilities.

Since 1978, Orange and Blue Line cars of the MBTA, and MARTA cars (an "A/B" pair and a "C") have made use of the TTC facility. A number of other special engineering tests have also been conducted here during this period. Miami,

Fla., and Baltimore, Md., cars are scheduled to be tested in 1982 and early 1983. The Niagara Frontier Transportation Authority's (NFTA) light rail vehicle will be tested during 1983.

Items tested include brake systems and brake pad materials, coupler wear, noise measurements, thermal capability of the propulsion system, energy consumption measurements and electromagnetic interference evaluation. Special tests like these, quickly run at TTC, could not readily be performed by a transit operator.

### **Wheel/Rail Dynamics**

The Wheel/Rail Dynamics Program (MA-06-0025) will improve urban transit system performance and reduce operating costs by reducing wear, component failure, derailment potential, energy consumption and noise, thereby optimizing ride quality. Roadbeds, trucks and vehicles have often been improperly designed, or, in many cases, the designs have been imperfectly understood. This has resulted in abnormal noise and wear, component failures, and potential safety hazards. These problems are reflected in unanticipated costs for material, labor and maintenance. The ultimate results are increased ridership costs, greater energy utilization, and reduced rail transit productivity.

Many quantifiable costs can be reduced by the Wheel/Rail Dynamics Program e.g., track replacement, wheel truing and replacement, lubrication and energy use. Recent analysis of the potential cost savings that could be achieved through the program have shown that a \$5 million expenditure for R&D in this area could generate a savings of \$19 to \$40 million.

Specific program activities are grouped by project area as follows: 1) steerable trucks, 2) wheel/rail wear, 3) truck design development, 4) truck/track maintenance and 5) special deployment projects.

Steerable trucks are being designed, tested and evaluated under two ongoing projects, one at the Port Authority Transit Corporation (PATCO), Philadelphia, Pa., and the other at WMATA. At PATCO, a prototype Budd steerable truck has been successfully operated in nonrevenue service. Wheel/rail wear projects include wear surveys, wear index development, wear mitigation studies, parametric analysis, and an evaluation of wheel profile effects at the Port Authority Trans-Hudson Corporation (PATH), N.Y. Examples of truck design development projects include truck/track characterization, shock and vibration effects, and performance limits evaluation. The principal activity in the area of truck/track maintenance is the development of a truck maintenance handbook. Special projects include the recent fastener and truck studies at WMATA, and the utilization of the tightturn loop at TTC.

The WMATA activity is also directed toward understanding the reasons for failures of direct-fixation track fasteners and excessive wheel/rail wear. Various types of fasteners have been instrumented, and an instrumented wheelset is being employed to measure the loads associated with track wear, wheel wear and fastener failure. Both the wheel profile and suspension stiffness are being varied to examine their effect on these phenomena. This is the first transit application of such an instrumented wheel, and it is also the most thorough quantification of wheel/rail

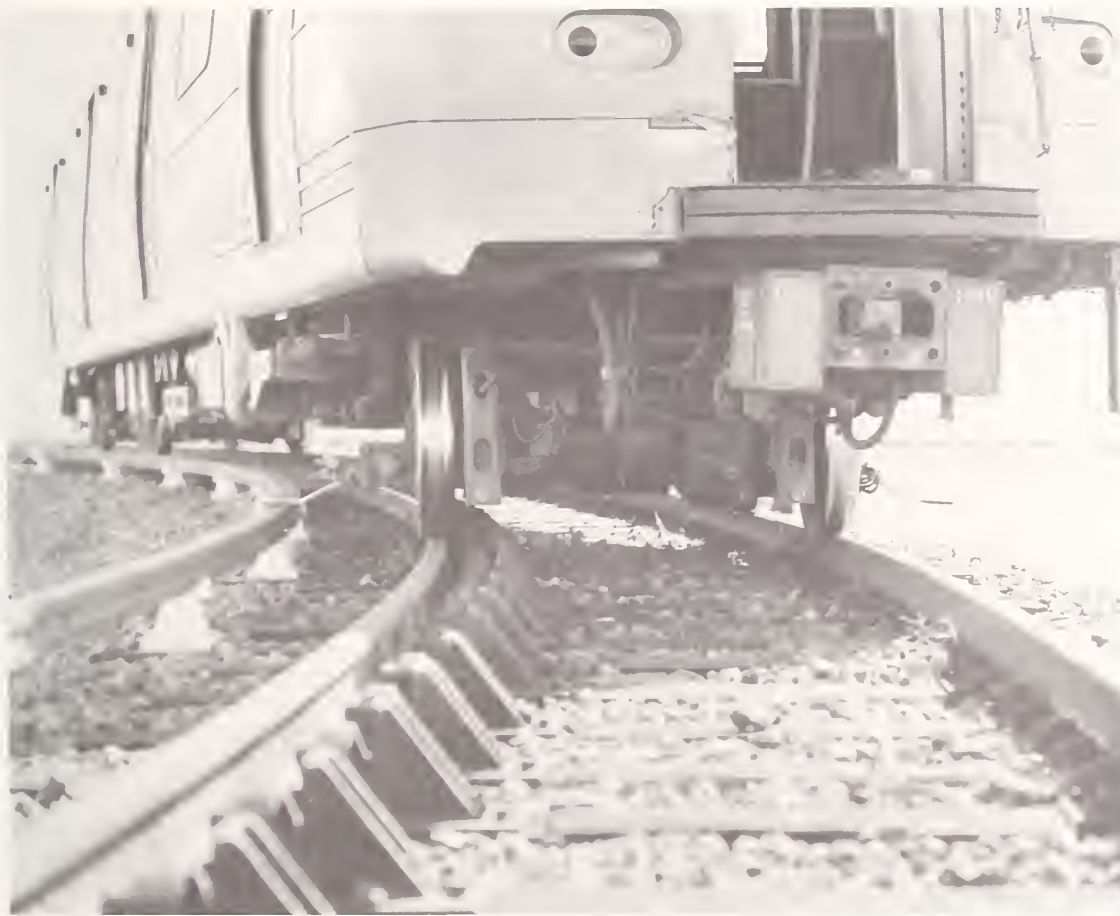

***Research sponsored by Wheel/Rail Dynamics Program can provide transit systems with substantial savings by reducing wheel/rail wear, component failure, derailment potential and energy consumption.***

dynamics ever measured on a transit system.

## Vehicle and Equipment Technology/STARS

There are presently 12 U.S. cities that have rapid rail transit systems in operation, under construction, or in the final en-

gineering phase: San Francisco, Chicago, Cleveland, Philadelphia, New York, Boston, Washington, Baltimore, Atlanta, Miami, Houston and Los Angeles.

In addition, the following urban areas have light rail systems planned, under construction, or in operation: Philadelphia, Boston, Pittsburgh, Newark, New Orleans, San Francisco, Cleveland, Buffalo, Santa Clara County, San Diego and Portland. In-

cluding commuter railroads, rail transit systems carry more than two billion passengers annually, or one-third of all mass transit riders. The reliability and availability of equipment is critical if this demand is to be met.

The Subsystem Technology Application to Rail Systems Program (STARS) emphasizes solutions for the day-to-day problems of operating and maintaining rail transit systems. This program identifies operational problems, and applies and deploys existing technology for near-term solutions.

The STARS program has had some major achievements. The development of hardware has been initiated for fare collection equipment, winterization equipment, AC propulsion and improved signalling circuits. Technology assessments have been conducted to quantify rail transit problems and to determine other potential STARS projects in the area of advanced propulsion systems, electromagnetic interference (EMI), energy optimization, air conditioning systems, doors and escalators.

### AC Propulsion

Alternating current propulsion systems provide potential operating cost benefits over conventional DC systems because the motors contain no brushes or armatures, which are high maintenance items. In addition, the inverter allows the motors to provide regenerative braking over a wide range of speeds. This reduces total energy consumption as well as wear on the friction brake system.

The AC Propulsion project is developing the technology to utilize alternating current induction motors to provide traction for rail transit systems. Two contrac-



tors, Garrett AiResearch (CA-06-0175) and Westinghouse Electric Company (IT-06-0253), received contracts in April 1982 for Phase I of the project, which includes design and analysis, and engineering model testing at the end of 1983. One contractor will then be selected for Phase II, which includes prototype fabrication, installation on two New York R-44 cars, testing at the Pueblo Transportation Test Center, and evaluation. Phase II is scheduled to be completed in early 1986. A third phase is planned which would include operation in revenue service.

### Escalators

In recent years, several U.S. rail systems have had frequent escalator breakdowns. UMTA has initiated a technology assessment to review current escalator technology, analyze operational data, and develop recommendations for future research and development. An Escalator Maintenance Reduction Liaison Board was established so that transit operators could contribute to the identification of problems. Based on recommendations of the board, UMTA has undertaken an investigation of the cost/safety/performance tradeoffs for various special design features of escalators (MA-06-0025).

### Winterization

The major snow storms of the winters of 1978 and 1979, which paralyzed many transit systems, alerted the industry to the special measures required to maintain operations during severe winter weather. In response, APTA formed a Task Force on Rail Transit Snow and Ice Emergencies. The Task Force concluded that there is a need for a high capacity, specialized snow removal vehicle.

*The AC Propulsion Project will explore the potential of this technology to reduce maintenance requirements and increase the reliability of urban rail operations.*

*AC propulsion technology has been successfully used by several conventional railroads in Europe for approximately 10 years.*



*DC Motor. Reliability of the DC motor depends on periodic maintenance of motor brushes and commutators. The access points on the motor housing, necessary for maintenance, allow dirt and moisture to enter the motor.*



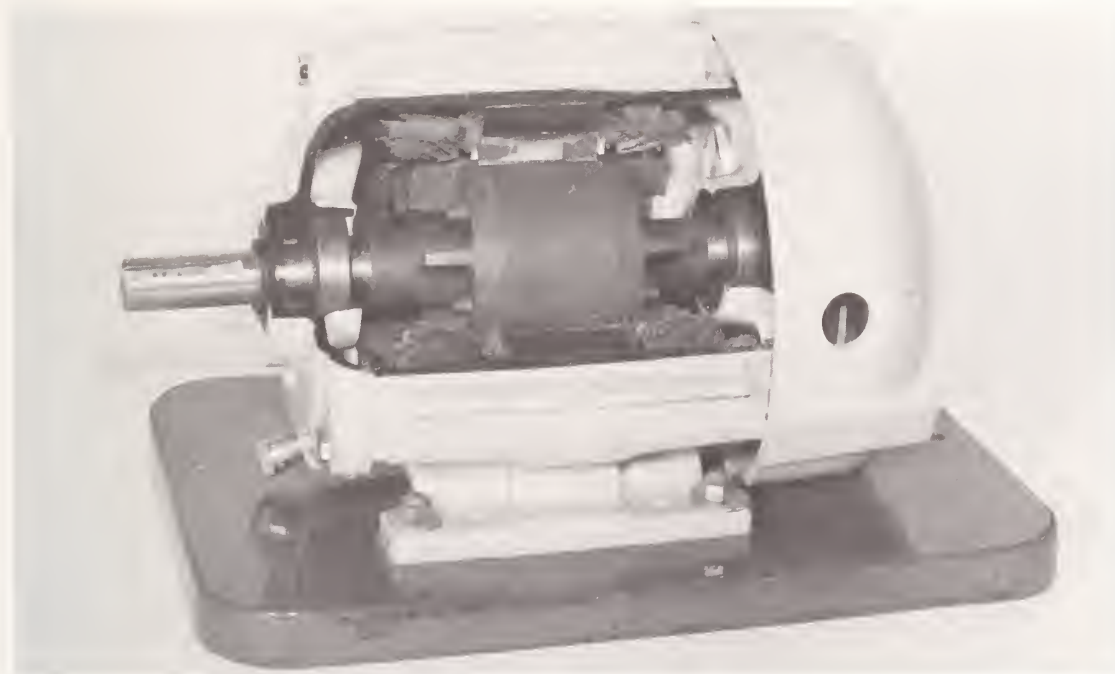

**AC Motor.** *Attractive features of the AC motor include: a) a totally sealed casing that protects the motor from harsh transit conditions and b) the lack of commutators, brushes, and armatures present in DC motors.*



**An experimental AC propulsion system will be installed and tested in a New York City Transit Authority R-44 subway train.**

In support of this activity, a contract previously awarded for a winterization technology and systems operation study was amended to develop specifications for a universal rail-mounted snow removal vehicle. CTA used these specifications for the procurement of a prototype vehicle, which was delivered in March 1981. CTA was awarded a grant to test and modify the vehicle (IL-06-0048) with technical support provided by TSC. The vehicle, in retrofitted form, is currently undergoing a testing program.

### **Fare Collection**

UMTA has initiated a TSC-directed project to improve the reliability and availability of rail transit fare collection equipment. The project involves equipment suppliers and is strongly supported by rail transit authorities, who participate in periodic workshops and in research and development grants. Grants have been awarded to PATCO (NJ-06-0012) for designing and testing a high reliability ticket vendor, and to CTA (IL-06-0049) for evaluating various pass reader systems. Other grants have been awarded for the development of an improved bill validator at the Illinois Central Gulf Railroad (ICG)(IL-06-0052), a centralized auditing and monitoring system at the MTA, Baltimore, Md. (MD-06-0091), and an improved turnstile at SEPTA (PA-06-0080).

The fare collection project is multifaceted, involving requirements analyses, product development, tests and evaluations. Reports have been completed describing specific issues and problems and assessing equipment reliability at BART and WMATA. Similar studies are underway with the MBTA, PATCO, CTA, ICG,



*This CTA magnetic card pass reader, developed and tested under UMTA sponsorship, should have applications at other transit systems as well.*

PATH and MARTA, in order to obtain a broad and uniform assessment of fare collection equipment. Workshops provide continued coordination among transit authorities and suppliers. Other project activities include model development for systems tradeoff studies, evaluation of hardware development at various systems, preparation of an equipment catalog, a policy impact study to aid agencies in equipment selection, and an evaluation of the operational effectiveness of foreign fare collection equipment.

## Energy

A computer model was developed by Carnegie-Mellon University to assess tractive energy conservation strategies. The model features two major modules: a train performance simulator, and an electrical network simulator. A separate module was designed to optimize results on the basis of cost. Model validation tests on the regeneration strategy were conducted. An industry/user workshop was held in 1981. Other completed activities in energy conservation include a grant to WMATA (DC-06-0315) to develop a methodology for auditing energy use, and

a study of energy utility rate structures by Carnegie-Mellon University (PA-06-0059) to provide the transit industry with criteria for use in energy management programs. A report by Booz, Allen and Hamilton that provides guidelines for increasing vehicle efficiency and reducing energy consumption will be completed in 1983.

## Electromagnetic Interference (EMI) and Compatibility (EMC)

Because of potential advantages in reliability, maintenance, and energy efficiency, solid-state propulsion control is increasingly being applied to rail transit.



*UMTA is assessing innovative foreign automatic fare collection equipment such as this passenger gate in Newcastle, England, to determine the potential for application on U.S. systems.*



Unfortunately, this new equipment can be electromagnetically incompatible with existing train control and signalling systems at certain U.S. transit facilities.

Since early 1979, UMTA, with technical support from TSC, has been working in a cooperative effort with transit operators, their consultants and suppliers to develop standardized methods of analysis and testing to quantify and resolve problems involving electromagnetic compatibility (EMC) in rail transit operations. A technical working group with an APTA advisory board has been established, and significant progress has been made toward solving this EMC problem.

Standardized guideline documents for testing intra-system electromagnetic compatibility between rail transit vehicular electrical power and track circuit signalling subsystems have been developed and may be requested by the industry from the Lang Transportation Committee of the Institute of Electrical and Electronic Engineers (IEEE).

Section 6 R&D grants were awarded to Baltimore, Md. (MD-06-0072), and Atlanta, Ga. (GA-06-0013), to develop cost-effective hardware designs to guarantee EMC between propulsion and signalling equipment. Based on these grants, new hardware designs and configurations have been developed and tested, and introduced into revenue service in Atlanta. The signalling hardware for Baltimore will be field-tested in 1983.

Cost-effective alternatives for EMC between chopper propulsion and signalling equipment for both new and existing systems have been developed. A system specific alternatives assessment (MA-06-0025) has been completed in support of the introduction of new chopper-con-

trolled vehicles at WMATA. In addition, the initial phase of a comprehensive assessment program for EMC in AC propulsion system development is nearing completion.

Planned EMI/EMC program activities include completion of the standardized guidelines, development of general vehicle EMC tests for the TTC, continuation of EMC analysis of advanced propulsion, and consideration of the program's orderly transfer to the transit industry. In FY 82, technical assistance was given to NFTA, MTA, Baltimore, Md., MARTA, MBTA and the Greater Cleveland Regional Transit Authority (GCRTA) for EMI testing of railcars and resolution of site specific EMI/EMC problems. Additional activities will include appropriate technical assistance to transit agencies on EMI problems, testing at NYCTA to determine the susceptibility of their track circuits to EMI, and cataloging transit system EMI emitters and receptors to assist U.S. industry in developing hardened train control circuitry.

### **Automatic Train Operation (ATO) and Automatic Train Control (ATC)**

The goal of this program is to improve the efficiency and safety of rail transit systems by matching the level of ATO/ATC (automation) to the specific needs of a transit system. This program is expected to produce guidelines and criteria by which senior transit management can evaluate proposed implementation plans for new transit systems or for the rehabilitation of existing systems. In FY 82, efforts were initiated to assess costs, reliability and maintainability of current and future signal and control systems. Concurrently, studies were conducted to review the state-of-the-art of microprocessor-

uses in ATO/ATC equipment and to determine the role of human factors in control and communications.

## **Construction Technology**

The Urban Rail Construction Technology Program focuses on near-term ways to decrease maintenance costs, increase productivity, and preserve deteriorating transit facilities. Federal concern with the potentially large cost of maintaining, upgrading, modernizing, rehabilitating or replacing the nation's transit facilities is increasing. Many rail transit systems are deteriorating and are unable to provide effective, reliable service.

The cost of rehabilitation could be minimized through a systematic, comprehensive, and consistent program for providing technical assistance to the transit operators. Technical assistance can help to increase transit system productivity and safety and facilitate maintenance and management. The program is based on a current assessment of the nation's rehabilitation and modernization needs, which will approach \$20 billion over the next decade.

### **Contracting and Management**

Studies by UMTA and others indicate that traditional institutional practices are a serious barrier to the deployment of innovative technology and actually contribute to the spiraling costs of transit. In response to these findings, UMTA has initiated R&D projects to develop contracting and management criteria for transit authorities. The inherent risks and complexities of underground construction and





***In building their new transit system, Buffalo was able to lower construction insurance costs due to innovative risk allocation techniques developed under UMTA sponsorship.***

rehabilitation are provided for in the formulation and assignment of these criteria. The risks assumed by parties to construction contracts must be fully understood and clear lines of authority and accountability must be established.

A study of risk allocation in urban underground construction (MA-06-0097) has been completed. This project developed a quantitative technique for analyzing how construction costs are affected by alternative risk allocation schemes for owners and designers. The results of this study have already been used to analyze the wrap-up insurance program devised by

NFTA and provide recommendations for the best type of insurance coverage for construction.

A computer model for Tunnel and Station Cost Estimating Methodology (TASCEM) was developed (MA-06-0100). This model has been used by the Southern California Rapid Transit District (SCRTD) to perform various construction cost tradeoffs for their preliminary designs. TASCEM was designed to help transit authorities develop cost effective designs for the different types of construction.

The Building Research Advisory

Board of the National Academy of Sciences has completed a study entitled Management of Urban Construction Programs (MA-06-0100). The study presents criteria that can be used as a guide by local government authorities in developing sound management plans for the execution of federally funded urban construction programs. It also identifies decision-making roles at all levels and presents criteria and procedures for assigning responsibility, authority and control. Two well attended seminars were conducted in Los Angeles and New York (May and November 1982) to disseminate the plan and discuss the program (DC-06-0345).

### **Elevated Structures**

Research on elevated structures is meant to produce recommendations for technology-based inspection, maintenance, and rehabilitation procedures. Deterioration and increasing rehabilitation costs for elevated structures are becoming major problems for many rail transit operators. There are over 160 miles of rail transit elevated structures in the United States, the majority requiring varying degrees of maintenance and rehabilitation because of age and environmental effects. In-service inspection, including determination of degradation, is important to assure that these structures are safe for public use. Public safety also demands the development of improved criteria for replacement and rehabilitation projects.

Currently underway is a project to develop a design practices handbook (MA-06-0076) for steel box girders. This handbook will provide specifications for designing rail transit elevated structures. Also underway is a related study (GA-06-0010) developing flexible criteria for the design

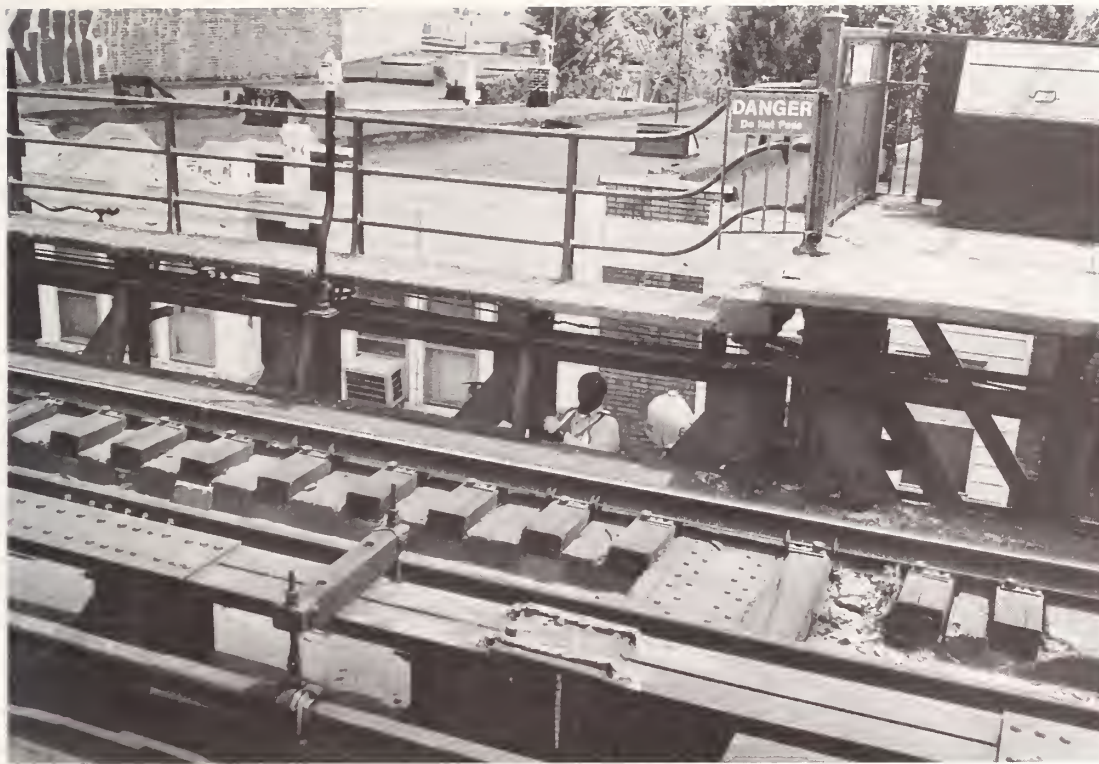

***Improved techniques for the inspection, maintenance, and rehabilitation of elevated structures are becoming more crucial due to the increasing age of many such structures.***

of elevated structures that will be suited to local conditions.

Future work will be directed toward maintenance and rehabilitation projects to minimize costs, increase productivity, and reduce local disruption and environmental impacts.

### **Track and Wayside Technology**

The objective of the Track and Wayside Technology Program is to improve the performance, reliability and safety of track, to reduce overall costs, and to optimize the use of rapid transit

track. Every effort is being made to coordinate these activities with the different sectors of the U.S. transit industry to insure that research efforts are directed toward solving real problems and that results are implemented. Through these cooperative efforts, the UMTA track research program will generate track design and construction standards, and maintenance guidelines.

A test section of track used to evaluate the noise characteristics of two different types of track structures in subway stations is underway in Chicago (IL-06-0042). The Chicago Urban Transportation

District, in cooperation with CTA, is evaluating direct fixation ties and ties made by STEDEF, Inc. Noise and ground vibration measurements will be taken in both railcars and station areas.

Improvements in industrial engineering procedures in rail transit maintenance have been identified in a recent study as an area of great potential for reducing the cost of maintaining ways and structures. A project (DC-06-0333) was initiated to develop a Track Maintenance Management Information System and a training program to assist in the introduction of new techniques in maintenance practices. Maintenance scheduling algorithms that are compatible with WMATA's planned deployment of a Track Geometry Measurement System (TGMS) will also be developed. The two projects are being closely coordinated.

The TGMS is a device that can be attached to any transit car to identify those portions of track in need of improvement. A prototype TGMS was developed at TSC and tested on the Toronto Transit Commission system for several months with successful results. NYCTA is currently conducting a two-year evaluation of the prototype. During FY 81, specifications for an improved system were jointly developed by industry and government.

### **Underground Structures**

Previously, the focus of this program was on reducing the cost of new urban underground construction, but the program has recently been redirected to help reduce the cost of maintaining and rehabilitating existing rail systems. Current projects involving subsurface exploration



and ground control, excavation, and tunnel linings will be completed, but rehabilitation projects will be emphasized.

Several tunneling studies are being made in the area of ground control and stabilization. Soil and construction parameters that affect the shifting of the ground around tunnels are being evaluated, and recommendations are being developed for procedures to predict and control these movements.

During site explorations for the MBTA Red Line Extension, innovative geotechnical methods were used to predict subsurface conditions in "critical" construction zones (MA-06-0100). The resulting predictions will be compared with actual conditions encountered in excavation. In addition, ground movements will be monitored as tunnel excavation proceeds.

For the past several years, instrumentation data has been collected from the BART Berkeley Hills Tunnels. An analysis of the data was made to determine the state of the instrumentation and the extent of any ground movement around the tunnels. A new instrumentation program will be developed for continued long-term monitoring (CA-06-0120).

The performance of the MBTA Porter Square station rock chamber and lining is being monitored during construction through the use of construction control instrumentation. This evaluation (MA-06-0127) will examine the validity of the design approach in comparison with other designs.

The NFTA project used four tunnel boring machines (TBM) to construct its rock tunnels. Two of the machines were new, the others rebuilt. A study (MA-06-0100) to evaluate the performance of all four machines in order to develop a data

base on TBM performance in rail transit construction has been completed.

Another study analyzing the effect of dipped guideways on the operation of underground rapid rail transit systems was completed. This study (CA-06-0144) investigated energy consumption during operation, as well as maintenance and operational impacts.

Guidelines are being developed for the structural design of tunnels based on the ultimate strength concepts of concrete behavior (MA-06-0100). The design recommendations will reflect the application of nonlinear, ultimate strength analysis methods to concrete tunnel lining design and will describe the beneficial effects of planned soil/structure interaction.

The development of an extruded tunnel lining system (ETLS) has been completed (MA-06-0100). The ETLS system is designed to continuously place the final tunnel support directly behind a TBM, thus eliminating the need for primary tunnel support and reducing construction time and cost.

To validate the ETLS concept, a series of 4-foot per hour tests were conducted using a 10-foot diameter prototype in a special test facility set up to serve as a mock tunnel. These tests successfully demonstrated 1) the control of form and bulkhead concrete pressure and flow; 2) a uniform filling of the space between the slip form and tunnel wall; 3) the capability of casting a self-supporting line, and 4) the acceptable quality of cast liner. Progress is continuing with the conduct of 7-foot per hour tests and the development of a full-scale concept design and systems specification. In addition, efforts are underway to locate a suitable site for conducting a field test of the ETLS.

Water intrusion into subway structures is a major problem. WMATA has been awarded a grant (DC-06-0347) to investigate problems related to water leakage (e.g., calcification of hydrostatic pressure relief drains, acid water corrosion, and water intrusion through tunnel and station structures). The study will develop and test recommended solutions such as grouting and interior waterproofing mediums.

A grant to PATH, in cooperation with NYCTA, involves a comprehensive investigation of existing and new technology applicable or adaptable for testing tunnel structural integrity (NY-06-0077). A reliable "nondestructive" method of testing will be developed. Such a method will be invaluable to older subway systems. It will also be useful in determining the condition of structures other than tunnels.

Another grant to WMATA (DC-06-0267) intended to validate specific portions of the Subway Environmental Simulation Program (SES) and to provide information for the Subway Environmental Design Handbook (MA-06-0100) has been completed. The data obtained will be used in predicting temperature distribution patterns during peak operating periods, safety ventilation operations, equipment operation costs, effectiveness of dome reliefs, and temperature stratification patterns in large stations typical of the WMATA system.

Fire safety in urban transit tunnels was also studied (MA-06-0100). This project was actually a continuation of SES, which developed a model to evaluate fire safety at any point in a subway by simulating a fire. This model makes it possible to draw up emergency evacuation plans and gives information on ventilation system





walls as an integral part of permanent underground transportation structures. Such an application could reduce the total cost of the project by combining costly temporary construction with the permanent structure.

***A WMATA study of water intrusion in tunnels addresses a problem common to most rail transit systems.***

control. This project has increased the predictive capabilities of the model and will make the program less expensive and easier to run. The computer model will be modified so that it can be run at TSC facilities, where it will be readily available to all transit agencies.

The Port Authority of Allegheny County (PAT), Pittsburgh, Pa., is preparing an alternative design for the construction of the Mount Lebanon Transit Tunnel (PA-06-0052). The PAT alternative is based on the New Austrian Tunneling Method, and is designed to offer this

method as an option to bidders for the construction of the tunnel.

The University of Illinois is analyzing data obtained during construction of WMATA tunnels (MA-06-0100). The primary objective of the study is to develop safer and more economical guidelines for the planning, design and construction of rock chambers and tunnels.

Instrumentation and Evaluation of Slurry Wall Construction is being conducted on the MBTA Red Line Extension (MA-06-0100). The purpose of the study is to evaluate the performance of slurry

## Rail and Construction Technology

| PROJECT TITLE   | NUMBER   | FUNDING          | SCHEDULE                  | AGENCY/<br>CONTRACTOR  | TECHNICAL<br>CONTACT              |
|---|--|------------------|---------------------------|--|-----------------------------------|
| <b>REQUIREMENTS ANALYSIS, AND EVALUATION</b>                            |  |                  |                           |  |                                   |
| Transit Reliability Information System                                  | MA-06-0060   | \$555,000        | Oct. 1980-<br>Sept. 1981  | TSC  | Fred L. Sing<br>(202) 426-0090    |
| Central Control Algorithm Assessment                                    | CA-06-0124   | \$150,000        | Sept. 1979-<br>Sept. 1981 | BART; Stanford Research Institute  | Stephen S. Teel<br>(202) 426-0090 |
| <b>SYSTEMS INTEGRATION AND DEPLOYMENT</b>                               |  |                  |                           |  |                                   |
| <b>Standardization</b>  |  |                  |                           |  |                                   |
| Railcar Standardization   | IT-06-0175<br>IT-06-0229<br>DC-06-0121<br>MA-06-0025 | \$1,900,000      | May 1976-<br>Dec. 1983    | APTA; N.D. Lea and Associates; Decision Group  | Jeffrey G. Mora<br>(202) 426-0090 |
| Rail Transit Design Digest  | DC-06-0186   | \$300,000        | Aug. 1978-<br>June 1982   | APTA   | Howard Evoy<br>(202) 426-9264     |
|   | IT-06-0271   | To Be Determined | Feb. 1982-<br>May 1983    | Tudor Engineering  | Jeffrey G. Mora<br>(202) 426-0090 |
| <b>Elderly and Handicapped Rail System Accessibility</b>                |  |                  |                           |  |                                   |
| Elderly and Handicapped Accessibility                                   | MA-06-0025   | \$1,000,000      | Sept. 1977-<br>Sept. 1982 | TSC; Veteran's Administration, Rehabilitation Center; Technology Research and Analysis Corp; Budd Co.; SFPUC | Jeffrey G. Mora<br>(202) 426-0090 |
|   | CA-06-0185   |                  |                           |  | Jason Baker<br>(617) 494-2188     |
| Analysis of Handicapped to Ascertain Design Requirement                 | IT-06-0243   | \$530,000        | Oct. 1980-<br>Oct. 1982   | Wilson-Hill Associates, Inc.   | Ross Adams<br>(202) 426-9267      |
| Improved Communication with the Visually Impaired in Rail Rapid Transit | MA-11-0036   | \$80,000         | July 1980-<br>June 1981   | Boston College   | Ross Adams<br>(202) 426-9267      |

## Rail and Construction Technology

| PROJECT TITLE  | NUMBER     | FUNDING     | SCHEDULE                  | AGENCY/<br>CONTRACTOR                                      | TECHNICAL<br>CONTACT                 |
|--|------------|-------------|---------------------------|--|--------------------------------------|
| <b>SYSTEMS INTEGRATION AND DEPLOYMENT (CONT.)</b>                      |            |             |                           |  |                                      |
| <b>Noise Abatement Technology</b>                                      |            |             |                           |  |                                      |
| Handbook of Urban Rail<br>Noise and Vibration<br>Control               | MA-06-0025 | \$110,000   | Sept. 1978-<br>Jan. 1982  | TSC; Wilson, Ihrig<br>and Associates                       | Michael G. Dinning<br>(617) 494-2506 |
| Wheel/Rail Technology  | MA-06-0099 | \$370,000   | July 1979-<br>Sept. 1981  | TSC; Bolt, Beranek<br>and New, Inc.                        | Michael G. Dinning<br>(617) 494-2506 |
| Damped Wheel In-Service<br>Test  | MA-06-0099 | \$175,000   | Feb. 1981<br>April 1983   | Cambridge Col-<br>laborative                               | Robert H. Hinckley<br>(617) 494-2203 |
| Resilient Fastener<br>Evaluation                                       | MA-06-0099 | \$10,000    | March 1979-<br>April 1982 | TSC; Chicago<br>(Ill.) Urban<br>Transportation<br>District | Howard Evoy<br>(202) 426-9264        |
| Propulsion System<br>Noise Control                                     | MA-06-0099 | \$285,000   | Jan. 1981-<br>Oct. 1982   | Bolt, Beranek<br>and Newman, Inc.                          | Robert H. Hinckley<br>(617) 494-2203 |
| Elevated Structures  | MA-06-0025 | \$415,000   | June 1978-<br>April 1982  | TSC; Bolt, Beranek<br>and Newman, Inc.                     | Robert H. Hinckley<br>(617) 494-2203 |
| Reduction of Groundborne<br>Noise and Vibration                        | MA-06-0099 | \$345,000   | Aug. 1979-<br>April 1982  | TSC; Wilson, Ihrig<br>and Associates                       | Michael G. Dinning<br>(617) 494-2506 |
| Procedure for Evaluation<br>of Abatement Cost<br>Effectiveness (PEACE) | MA-06-0099 | \$125,000   | April 1979-<br>Feb. 1982  | TSC; Polytechnic<br>Institute of New<br>York               | Robert H. Hinckley<br>(617) 494-2203 |
| Acoustical Materials<br>Compendium                                     | MA-06-0099 | \$75,000    | Nov. 1980-<br>April 1982  | Operations Research,<br>Inc.                               | Michael G. Dinning<br>(617) 494-2506 |
| Noise Control  | MA-06-0099 | \$35,000    | Sept. 1982-<br>Sept. 1983 | Energy and Environ-<br>mental Engineering,<br>Inc.         | Michael G. Dinning<br>(617) 494-2506 |
| <b>Comprehensive Testing</b>   |            |             |                           |  |                                      |
| TTC Support  | CO-06-0009 | \$1,550,000 | Oct. 1981-<br>Oct. 1983   | FRA; Boeing<br>Services Inter-<br>national; AAR            | Fred L. Sing<br>(202) 426-0090       |



## Rail and Construction Technology

| PROJECT TITLE                                     | NUMBER     | FUNDING     | SCHEDULE                 | AGENCY/<br>CONTRACTOR  | TECHNICAL<br>CONTACT                  |
|---|------------|-------------|--------------------------|--|---------------------------------------|
| <b>SYSTEMS INTEGRATION AND DEPLOYMENT (CONT.)</b> |            |             |                          |  |                                       |
| <b>Wheel/Rail Dynamics</b>                        |            |             |                          |  |                                       |
| Steerable Truck Evaluation                        | MA-06-0025 | \$900,000   | Aug. 1977-<br>July 1982  | TSC; Budd Co.;<br>Urban Transporta-<br>tion Development<br>Corp. | Charles O. Phillips<br>(617) 494-2634 |
| Wheel/Rail Wear Investigation                     | MA-06-0025 | \$200,000   | July 1981-<br>June 1982  | TSC  | Charles O. Phillips<br>(617) 494-2634 |
| Truck Performance Limits                          | MA-06-0025 | \$60,000    | June 1980-<br>June 1983  | TSC; Massachusetts<br>Institute of<br>Technology                 | Charles O. Phillips<br>(617) 494-2634 |
| Truck/Track Maintenance                           | MA-06-0025 | \$150,000   | Oct. 1981-<br>Dec. 1983  | TSC  | Charles O. Phillips<br>(617) 494-2634 |
| Washington Metropolitan Area Transit Authority    | MA-06-0025 | \$50,000    | April 1981-<br>Aug. 1982 | TSC; Ensco, Inc.;<br>Batelle Columbus<br>Laboratory              | Charles O. Phillips<br>(617) 494-2634 |
| <b>VEHICLE AND EQUIPMENT TECHNOLOGY/STARS*</b>    |            |             |                          |  |                                       |
| <b>AC Propulsion</b>                              |            |             |                          |  |                                       |
| AC Propulsion Project                             | CA-06-0175 | \$1,351,000 | April 1982-<br>Dec. 1983 | Garrett AiResearch   | Raymond A. Wlodyka<br>(617) 494-2604  |
| AC Propulsion Project                             | IT-06-0253 | \$2,510,000 | April 1982-<br>Dec. 1983 | Westinghouse<br>Electric Company                                 | Raymond A. Wlodyka<br>(617) 494-2604  |
| AC Propulsion Project                             | IT-06-0253 | \$291,000   | March 1982-<br>Jan. 1986 | N.D. Lea and<br>Associates                                       | Robert C. Hoyler<br>(202) 426-0090    |

\*STARS — Subsystem Technology Applications to Rail Systems.

## Rail and Construction Technology

| PROJECT TITLE   | NUMBER     | FUNDING   | SCHEDULE                  | AGENCY/<br>CONTRACTOR                               | TECHNICAL<br>CONTACT               |
|---|------------|-----------|---------------------------|---|------------------------------------|
| <b>VEHICLE AND EQUIPMENT TECHNOLOGIES/STARS (CONT.)</b>           |            |           |                           |   |                                    |
| <b>Fare Collection</b>  |            |           |                           |   |                                    |
| Fare Collection Ticket Dispenser Development                      | NJ-06-0012 | \$100,000 | Oct. 1980-<br>March 1982  | PATCO   | Joseph S. Koziol<br>(617) 494-2546 |
| Fare Collection Pass Reader Evaluation                            | IL-06-0049 | \$200,000 | Oct. 1981-<br>Jan. 1982   | CTA, Chicago, Ill.                                  | Joseph S. Koziol<br>(617) 494-2546 |
| Fare Collection Bill Verifier Project                             | IL-06-0052 | \$263,000 | To be<br>Determined       | Chicago (Ill.)<br>Regional Transportation Authority | Joseph S. Koziol<br>(617) 494-2546 |
| Fare Collection Monitor and Auditing Project                      | MD-06-0091 | \$300,000 | To Be<br>Determined       | MTA, Baltimore, Md.                                 | Ronald D. Kangas<br>(202) 426-9264 |
| Improved Turnstile  | PA-06-0080 | \$225,000 | Sept. 1982-<br>May 1984   | SEPTA   | Joseph S. Koziol<br>(617) 494-2546 |
| <b>Escalators</b>   |            |           |                           |   |                                    |
| Escalator Assessment  | MA-06-0025 | \$60,000  | April 1980-<br>Dec. 1981  | Jet Propulsion<br>Laboratory                        | Joseph S. Koziol<br>(617) 494-2546 |
| <b>Winterization</b>  |            |           |                           |   |                                    |
| Snow Removal Equipment  | IL-06-0048 | \$100,000 | Oct. 1980-<br>Oct. 1982   | CTA, Chicago, Ill.                                  | Jason B. Baker<br>(617) 494-2188   |
| <b>Energy</b>   |            |           |                           |   |                                    |
| Energy Assessment   | DC-06-0315 | \$110,000 | May 1980-<br>May 1981     | WMATA   | Ronald D. Kangas<br>(202) 496-9264 |
| Energy Rate Analysis  | PA-06-0059 | \$100,000 | June 1980-<br>Nov. 1981   | Carnegie-Mellon<br>University                       | Ronald D. Kangas<br>(202) 426-9264 |
| <b>Electromagnetic Interference (EMI) and Compatibility (EMC)</b> |            |           |                           |   |                                    |
| EMI Countermeasures   | MD-06-0072 | \$400,000 | Feb. 1980-<br>Oct. 1983   | MTA, Baltimore, Md.                                 | Fred L. Sing<br>(202) 426-9264     |
| EMI Countermeasures   | GA-06-0013 | \$195,000 | June 1980-<br>April 1981  | MARTA   | Lennart E. Long<br>(617) 494-2262  |
| EMI Substation Project  | MA-06-0025 | \$118,000 | April 1980-<br>Sept. 1981 | OAO Corp.   | Lennart E. Long<br>(617) 494-2262  |

## Rail and Construction Technology

| PROJECT TITLE   | NUMBER     | FUNDING   | SCHEDULE                  | AGENCY/<br>CONTRACTOR                              | TECHNICAL<br>CONTACT               |
|---|------------|-----------|---------------------------|--|------------------------------------|
| <b>VEHICLE AND EQUIPMENT TECHNOLOGIES/STARS (CONT.)</b>                   |            |           |                           |  |                                    |
| <b>Electromagnetic Interference (EMI) and Compatibility (EMC) (Cont.)</b> |            |           |                           |  |                                    |
| EMI Propulsion System   | VA-06-0075 | \$100,000 | Dec. 1979-<br>Jan. 1982   | Unified Industries                                 | Ronald D. Kangas<br>(202) 426-9264 |
| EMI Specification<br>Development  | MA-06-0059 | \$500,000 | Jan. 1980-<br>Dec. 1981   | TSC; Pacific<br>Consultants;<br>Radiation Sciences | Lennart E. Long<br>(617) 494-2262  |
| <b>Air Conditioning</b>   |            |           |                           |  |                                    |
| Air Conditioning<br>Project   | IT-06-0250 | \$238,000 | May 1982-<br>Dec. 1983    | Data Communications,<br>Inc.                       | Jeffrey Mora<br>(202) 426-0090     |
| <b>CONSTRUCTION TECHNOLOGY</b>  |            |           |                           |  |                                    |
| <b>Contracting and Management</b>   |            |           |                           |  |                                    |
| Allocation of Risk in<br>Construction                                     | MA-06-0097 | \$142,000 | July 1979-<br>Feb. 1982   | Massachusetts<br>Institute of<br>Technology        | Howard Evoy<br>(202) 426-9264      |
| Construction Cost<br>Estimating Methodology                               | MA-06-0100 | \$220,000 | Jan. 1980-<br>Sept. 1983  | TSC  | John Putukian<br>(617) 494-2275    |
| Project Management<br>Seminars  | DC-06-0345 | \$50,000  | Aug. 1981-<br>Aug. 1982   | TSC; National<br>Academy of<br>Sciences            | Raymond Williams<br>(202) 426-0090 |
| <b>Elevated Structures</b>  |            |           |                           |  |                                    |
| Design Practices for<br>Steel Box Girders                                 | MA-06-0076 | \$90,000  | May 1980-<br>July 1983    | University of<br>Maryland                          | Howard Evoy<br>(202) 426-9264      |
| Development of Design<br>Criteria for Aerial<br>Structures                | GA-06-0010 | \$135,000 | Dec. 1978-<br>April 1983  | Harrington, George<br>and Dunn, Inc.               | Howard Evoy<br>(202) 426-9264      |
| Design Analysis of<br>Elevated Structures                                 | MA-06-0096 | \$57,000  | Sept. 1979-<br>March 1982 | Massachusetts<br>Institute of<br>Technology        | Paul R. Spencer<br>(202) 426-0090  |



## Rail and Construction Technology

| PROJECT TITLE  | NUMBER     | FUNDING     | SCHEDULE                 | AGENCY/<br>CONTRACTOR                                 | TECHNICAL<br>CONTACT                 |
|--|------------|-------------|--------------------------|---|--------------------------------------|
| <b>CONSTRUCTION TECHNOLOGY (CONT.)</b>                     |            |             |                          |   |                                      |
| <b>Track and Wayside Technology</b>                        |            |             |                          |   |                                      |
| Transit Track/Noise<br>Test Section                        | IL-06-0042 | \$700,000   | Nov. 1978-<br>July 1983  | Chicago, (Ill.)<br>Urban Transporta-<br>tion District | Howard Evoy<br>(202) 426-9264        |
| Industrial Engineering<br>Support for Track<br>Maintenance | DC-06-0333 | \$1,200,000 | Oct. 1980-<br>Oct. 1983  | WMATA   | Howard Evoy<br>(202) 426-9264        |
| Rehabilitation Research<br>Needs Study                     | MA-06-0100 | \$238,000   | Dec. 1979-<br>March 1982 | TSC; Urban Trans-<br>portation Develop-<br>ment Corp. | Gerald R. Saulnier<br>(617) 494-2356 |
| Track Structure Shear<br>Test                              | MA-06-0100 | \$75,000    | Aug. 1980-<br>Aug. 1982  | TSC; University of<br>Arizona                         | John Putukian<br>(617) 494-2275      |
| Concrete Tie Deployment<br>Analysis                        | MA-06-0100 | \$20,000    | Dec. 1981-<br>March 1982 | TSC; Delon Hampton<br>Associates                      | Gerald R. Saulnier<br>(617) 494-2356 |
| <b>Underground Structures</b>                              |            |             |                          |   |                                      |
| MBTA Site<br>Exploration                                   | MA-06-0100 | \$486,000   | Oct. 1978-<br>June 1982  | TSC; Bechtel Corp.;<br>Haley and Aldrich,<br>Inc.     | Philip A. Mattson<br>(617) 494-2741  |
| Berkeley Hills Tunnel<br>Instrumentation<br>Analysis       | CA-06-0120 | \$100,000   | Dec. 1978-<br>July 1982  | BART  | Howard Evoy<br>(202) 426-9264        |
| Porter Square Design<br>Evaluation                         | MA-06-0127 | \$235,000   | Oct. 1980-<br>Dec. 1982  | MBTA  | Howard Evoy<br>(202) 426-9264        |
| Tunnel Boring Machine<br>Evaluation                        | MA-06-0100 | \$164,000   | July 1980-<br>June 1983  | TSC; Goldberg,<br>Zoino and Associates                | Paul J. Witkiewicz<br>(617) 494-2277 |
| Analysis of Dipped<br>Guideways for Rail                   | CA-06-0144 | \$178,000   | July 1980-<br>June 1982  | Jet Propulsion<br>Laboratory                          | Howard Evoy<br>(202) 426-9264        |

## Rail and Construction Technology

| PROJECT TITLE  | NUMBER     | FUNDING     | SCHEDULE                  | AGENCY/<br>CONTRACTOR                         | TECHNICAL<br>CONTACT                 |
|--|------------|-------------|---------------------------|---|--------------------------------------|
| <b>CONSTRUCTION TECHNOLOGY (CONT.)</b>                 |            |             |                           |   |                                      |
| <b>Underground Structures (Cont.)</b>                  |            |             |                           |   |                                      |
| Design Recommendations for Concrete Tunnel Liners      | MA-06-0100 | \$350,000   | April 1978-<br>Feb. 1983  | TSC; University of Illinois, Urbana-Champaign | Gerald R. Saulnier<br>(617) 494-2356 |
| Development of an Extruded Tunnel Lining System (ETLS) | MA-06-0100 | \$2,051-000 | Jan. 1978-<br>March 1983  | TSC; Foster Miller Associates, Inc.           | Gerald R. Saulnier<br>(617) 494-2356 |
| ETLS Deployment Analysis                               | MA-06-0100 | \$30,000    | Oct. 1980-<br>Oct. 1982   | TSC; Delon Hampton Associates                 | Gerald R. Saulnier<br>(617) 494-2356 |
| Investigation of Water Intrusion Problems              | DC-06-0347 | \$455,000   | March 1981-<br>March 1983 | WMATA   | Howard Evoy<br>(202) 426-9264        |
| Nondestructive Testing (NDT) Tunnel Inspection         | NY-06-0077 | \$800,000   | April 1980-<br>Oct. 1983  | PATH  | Howard Evoy<br>(202) 426-9264        |
| Validation of WMATA Ventilation Design                 | DC-06-0267 | \$469,000   | Aug. 1979-<br>March 1982  | WMATA   | Howard Evoy<br>(202) 426-9264        |
| Subway Environmental Simulation: Emergency Ventilation | MA-06-0100 | \$210,000   | Nov. 1978-<br>Sept. 1983  | TSC; Parsons, Brinkerhoff, Quade and Douglas  | Anna A. Synder<br>(617) 494-2239     |
| New Australian Tunneling Method (NATM) Test Section    | PA-06-0052 | \$484,000   | June 1979-<br>Feb. 1983   | PAT   | Howard Evoy<br>(202) 426-9264        |
| Analysis of WMATA Construction Monitoring Data         | MA-06-0100 | \$40,000    | March 1979-<br>March 1982 | TSC; FHWA; WMATA                              | James H. Lamond<br>(617) 494-2741    |

## Rail and Construction Technology

| PROJECT TITLE  | NUMBER                   | FUNDING   | SCHEDULE                  | AGENCY/<br>CONTRACTOR  | TECHNICAL<br>CONTACT                 |
|--|--------------------------|-----------|---------------------------|--|--------------------------------------|
| <b>CONSTRUCTION TECHNOLOGY (CONT.)</b>                     |                          |           |                           |  |                                      |
| <b>Underground Structures (Cont.)</b>                      |                          |           |                           |  |                                      |
| Monitoring of MBTA<br>Slurry Wall<br>Construction          | MA-06-0100               | \$50,000  | March 1979-<br>Sept. 1982 | TSC; FHWA; MBTA  | James H. Lamond<br>(617) 494-2741    |
| Precast Concrete<br>Liners Test Section                    | MD-06-0029<br>MD-06-0039 | \$728,000 | Oct. 1978-<br>June 1982   | MTA, Baltimore, Md.  | Howard Evoy<br>(202) 426-9264        |
| Tunneling Technology<br>Workshops and Seminars             | DC-06-0368               | \$50,000  | Oct. 1981-<br>Oct. 1982   | TSC; OAO Corp.   | Howard Evoy<br>(202) 426-9264        |
| Rock Station and<br>Tunnel Test Section                    | GA-06-0007               | \$480,000 | Aug. 1977-<br>March 1982  | MARTA  | Howard Evoy<br>(202) 426-9264        |
| In Situ Stress<br>Measurements in Tunnels                  | DC-06-0312               | \$27,000  | Aug. 1980-<br>June 1982   | National Science<br>Foundation<br>University of<br>California,<br>Berkeley | Howard Evoy<br>(202) 426-9264        |
| Geologic Site<br>Investigation for<br>Tunnels              | MA-06-0100               | \$357,000 | Oct. 1981-<br>Oct. 1983   | TSC; National<br>Academy of Sciences                                       | Philip A. Mattson<br>(617) 494-2741  |
| Program Development<br>Support                             | MA-06-0100               | \$50,000  | Oct. 1981-<br>Oct. 1982   | TSC; OAO Corp.   | Gerald R. Saulnier<br>(617) 494-2356 |
| Evaluation of Deep<br>Weather Rock:<br>Forest Glen Station | DC-06-0343               | \$55,000  | Feb. 1981-<br>Dec. 1982   | WMATA  | Howard Evoy<br>(202) 426-9264        |

### Bibliography

A list of recent reports follows. Please consult previous editions of this Directory for earlier reports. If available, a document number assigned by the National Technical Information Service (NTIS) is listed. Reports may be obtained from NTIS by

using the order blanks provided at the end of this document.

Reports which have not been assigned an NTIS number may not have been published in sufficient quantity for general distribution. Single copies and other information may be available from the issuing agency or organization.

Additional reports relating to the research described in this chapter may become available in the near future. For the most recent information or suggestions for additional reference materials regarding specific projects, call or write to the person listed as the technical contact in the Project Summary Table.



## REQUIREMENTS ANALYSIS, AND EVALUATION

### **Central Control System Survey**

Proj. CA-06-0124  
SRI International  
May 1981, PB 82-101-981

### **Transit Reliability Information Program Experimental Data Bank**

**Vol. I, Operating Procedures Manual**  
Proj. MA-06-0060  
Transportation Systems Center  
April 1981, UMTA-MA-06-0060-81-4

### **Transit Reliability Information Program Experimental Data Bank**

**Vol. II, Appendices**  
Proj. MA-06-0060  
Transportation Systems Center  
April 1981, UMTA-MA-06-0060-81-5

### **Transit Reliability Information Program Maintenance Manual**

Proj. MA-06-0060  
Transportation Systems Center  
January 1981

### **Transit Reliability Information Program Participants Guidelines**

Proj. MA-06-0060  
Transportation Systems Center  
March 1981, PB 81-189-276

### **Transit Reliability Information Program (TRIP)—Phase I**

Proj. MA-06-0060  
Transportation Systems Center  
June 1981, PB 81-231-425

### **Transit Reliability Information Program Verification Demonstration Plan for Rapid Rail Vehicles**

Proj. MA-06-0060  
Transportation Systems Center  
August 1981, PB 82-118-464

## SYSTEMS INTEGRATION AND DEPLOYMENT

### **Standardization**

#### **An Investigation of Rail Rapid Transit Carbody Materials**

Proj. IT-06-0175  
Decision Group  
March 1980, PB 80-170-970

#### **The Service Evaluated Products List for Rapid Transit Systems Components**

Proj. IT-06-0175  
Decision Group  
March 1981, PB 81-225-666

#### **Initial Interface Standards for Rapid Transit Car Subsystem Components**

Proj. IT-06-0175  
Decision Group  
June 1981, PB 82-104-704

#### **Transit Industry Core Specification for the Procurement of Rapid Railcars**

Proj. IT-06-0175  
Decision Group  
July 1981

#### **Proposed Analysis Methodology for Rail Car Propulsion System Selection**

Proj. IT-06-0229  
N. D. Lea and Associates  
May 1980, PB 80-201-460

#### **Roster of North American Rapid Transit Cars 1945-1980 (2nd Edition)**

Proj. DC-06-0121  
American Public Transit Association  
July 1980, PB 81-213-564

#### **A Study of Transit Railcar Guarantee, Warranty, and Reliability Contractual Provisions**

Proj. IT-06-0229  
N.D. Lea and Associates  
February 1982, PB 82-246141

#### **Benefits of Railcar Standardization**

Proj. IT-06-0229

N.D. Lea and Associates  
February 1982, PB 82-221615

#### **Light Rail Transit Car Specification Guide**

Proj. MA-06-0025  
N. D. Lea and Associates  
December 1981, PB 82-190737

#### **Elderly and Handicapped Rail Accessibility**

#### **The Feasibility of Retrofitting Lifts on Commuter and Light Rail Vehicles**

Proj. MA-06-0025  
Technology Research and Analysis  
Corporation  
September 1980, PB 81-130-684

#### **Summary Report of 321(b) Rail Retrofit Evaluation**

**Vol. I, Light and Commuter Rail Systems**  
Proj. CA-06-0125  
Crain and Associates  
December 1980, PB 81-187-148

#### **Station Platform-Railcar Threshold Gap Study**

Proj. MA-06-0025  
Veterans Administration Rehabilitation  
Engineering Center  
March 1982, PB 82-213505

#### **Accessibility for Level-Entry Urban Rail Systems**

Proj. MA-06-0025  
Technology Research and Analysis  
Corporation  
April 1982, PB 82-225558

#### **Escalator Modification for the Handicapped: Phase I, Final Report**

Proj. IT-06-0164  
Foster Miller Associates, Inc.  
July 1980, UMTA-IT-06-0164-80-01

#### **Transit Station Use by the Handicapped: Vertical Movement Technology**

Contract No. DOT-UT-80040  
Transportation Research Board  
April 1980, PB 81-129-991

**Improving Communications with the Visually Impaired in Rail Rapid Transit Vol. I, Solutions for Problems of Visually Impaired Users of Rail Rapid Transit**

**Vol. II, Information about Visual Impairment for Architects and Transit Planners**

Proj. MA-11-0036

Boston College

August 1981, UMTA-MA-11-0036-81-1,2

**Noise Abatement Technology**

**Urban Rail Noise Abatement Program: A Description**

Proj. MA-06-0099

Transportation Systems Center

March 1979, PB 295-545

**Noise Rating Criteria for Elevated Rapid Transit Structures**

Proj. MA-06-0099

Bolt, Beranek and Newman, Inc.

May 1979, PB 297-419

**In-Service Performance and Costs of Methods for Control of Urban Rail System Noise: Experimental Design**

Proj. MA-06-0025

DeLeuw Cather and Company; Wilson, Ihrig and Associates

May 1976, PB 257-200

**Noise Assessment of the New York City Rail Rapid Transit System**

Proj. MA-06-0025

Polytechnic Institute of New York

January 1979, PB 292-498

**Noise Degradation Over Time of Rail Rapid Transit Cars**

Proj. NY-11-0002

Polytechnic Institute of New York

December 1978, PB 292-031

**In-Service Performance and Costs of Methods to Control Urban Rail System Noise: Final Report**

Proj. MA-06-0099

Wilson, Ihrig and Associates; DeLeuw

Cather and Company

December 1979, PB 80-129-216

**Urban Rail Noise Abatement Program: A Description**

Proj. MA-06-0099

Transportation Systems Center

January 1980, PB 295-545/8

**Noise Control for Rapid Transit Cars on Elevated Structures: Preliminary Investigation of Vehicle Skirts, Undercar Absorption and Noise Barriers**

Proj. MA-06-0099

Bolt, Beranek and Newman, Inc.

April 1980, PB 80-213-077

**Urban Rail Noise Abatement Program Digest**

Proj. MA-06-0099

Transportation Systems Center

May 1980, UMTA-MA-06-0099-80-3

**Noise Impact Inventory of Elevated Structures in U.S. Urban Rail Rapid Transit Systems (Interim Report)**

Proj. MA-06-0099

Bolt, Beranek and Newman, Inc.

September 1980, PB 81-120-958

**Wayside Noise of Elevated Rail Transit Structures: Analysis of Published Data and Supplementary Measurements (Interim Report)**

Proj. MA-06-0099

Bolt, Beranek and Newman, Inc.

December 1980, PB 81-196-857

**Wheel/Rail Noise Control—A Critical Evaluation (Interim Report)**

Proj. MA-06-0099

Bolt, Beranek and Newman, Inc.

January 1981, UMTA-MA-06-0099-81-1

**Vibration Levels Data Brighton-New York City Transit Authority (Final Report)**

Proj. MA-06-0099

Transportation Systems Center

February 1981, PB 81-202-814

**Evaluation of Squeal Noise from the WMATA Transit Car Disc Brake System: A Preliminary Investigation (Final Report)**

Proj. MA-06-0049

ORI, Inc.

March 1981, UMTA-MA-06-0049-81-4

**Handbook of Urban Rail Noise and Vibration Control**

Proj. MA-06-0099

Transportation Systems Center

February 1982, UMTA-MA-06-0099-82-1

**Executive Digest of the Handbook of Urban Rail Noise and Vibration Control**

Proj. MA-06-0099

Transportation Systems Center

February 1982, UMTA-MA-06-0099-82-2

**Comprehensive Testing**

**Transportation Test Center Rail Transit Services**

Proj. MD-06-0032

Onyx Corporation

May 1981, PB 82-176975

**Massachusetts Bay Transportation Authority Blue Line Vehicle Evaluation: Final Report**

Proj. FRA-TTC-80-05

August 1980, PB 81-102949

**Massachusetts Bay Transportation Authority No. 12 Orange Line Vehicle Evaluation**

K. Simmonds, G. Arnold

October 1981, PB 179938

**Metropolitan Atlanta Rapid Transit Authority, Transit Vehicle Engineering Tests**

Proj. FRA-TTC-81-05

October 1981, PB 82-126393

**Wheel/Rail Dynamics**

**Analysis of Wheel/Rail Force and Flange Force During Steady-State Curving of Rigid Trucks**

Proj. MA-06-0025

Transportation Systems Center  
September 1980, PB 81-103459

**Measurement of Wheel/Rail Forces at the Washington Metropolitan Area Transit Authority**

Proj. MA-06-0025  
Transportation Systems Center  
July 1980, PB 80-212-772

**Measurement of Wheel/Rail Forces at the Washington Metropolitan Area Transit Authority**

**Vol. II, Test Report**  
Proj. MA-06-0025  
D. Ahlheck, H. Harrison, and J. Tuten  
July 1980, PB 81-103-327

**Wheel/Rail Force Measurements at the Washington Metropolitan Area Transit Authority, Phase II**

**Vol. I, Analysis Report**  
Proj. MA-06-0025-82-25  
Ensco, Inc.  
October 1982

**International Conference on Wheel/Rail Load and Displacement Measurement Techniques**

Proj. DOT-TSC-UM104-PM  
C. Mekoah  
December 1980

**A Wheel/Rail Wear Study for Railroad Transit Systems**

Proj. MA-06-0025  
S. Kumar, D. Prasanna Rao  
August 1980

**Limiting Forces on Transit Trucks in Steady-State Curving**

Proj. MA-06-0025  
Transportation Systems Center  
August 1981, UMTA-MA-06-0025-81-69

**Increased Rail Transit Vehicle Crashworthiness in Head-On Collisions Vol. I, Initial Impact: Final Report**

Proj. MA-06-0025  
E. Hahn  
June 1980, PB 80-205-727 *A04*

**Increased Rail Transit Vehicle Crashworthiness in Head-On Collisions Vol. II, Primary Collision: Final Report**

Proj. MA-06-0025  
E. Hahn, S. Walgrave, and T. Liber  
June 1980, PB 80-205-743 *A05*

**Increased Rail Transit Vehicle Crashworthiness in Head-On Collisions Vol. III, Guidelines for Evaluation and Development of New Railcar Designs: Final Report**

Proj. MA-06-0025 *Rejected by NTIS*  
A. Wiedermann, A. Longinew, and E. Hahn  
June 1980, UMTA-MA-06-0025-80-3

**Increased Rail Transit Vehicle Crashworthiness in Head-On Collisions Vol. IV, Train User's Manual: Final Report**

Proj. MA-06-0025 *PB*  
E. Hahn  
June 1980, PB 80-205-735 *All*

**VEHICLE AND EQUIPMENT TECHNOLOGY/STARS**

**Dual-Powered Gas Turbine/Electric Commuter Rail Cars: Test, Evaluation, and Economics**

Proj. NY-06-0005  
Metropolitan Transportation Authority  
September 1980, PB 81-211-757

**Proceedings of the International Conference on Advanced Propulsion Systems for Urban Rail Vehicles**

Proj. VA-06-0053  
MITRE Corporation  
February 1980, PB 80-149-099

**Fare Collection**

**Automatic Fare Collection Equipment, Reliability and Maintainability Assessment Plan for Urban Rail Transit Properties**

Proj. MA-06-0025  
Automated Services, Inc.  
March 1981, UMTA-MA-06-0025-81-1

**Assessment of WMATA's Automatic Fare Collection Equipment Performance**

Proj. MA-06-0080  
Input/Output Computer Services  
January 1981, UMTA-MA-06-0080-80-1

**Overview of Rail Transit Fare Collection**

Proj. CA-06-0116  
Jet Propulsion Laboratory  
August 1980, UMTA-CA-06-0116-80-1

**Description and Evaluation of the MBTA Magnetic Card Fare Collection System**

Proj. MA-06-0025  
Dynatrend, Inc.  
September 1981, UMTA-MA-06-0025-81-2

**Rail Transit Fare Collection Technology Assessment**

Proj. MA-06-0025  
Jet Propulsion Laboratory  
In Process

**Escalators**

**Overview of Escalator Applications in Rail Transit**

Proj. CA-06-0116  
Jet Propulsion Laboratory  
July 1980, PB 81-128-720

**Escalator Design Features Evaluation**

Proj. MA-06-0026  
Jet Propulsion Laboratory  
May 1982, PB 82-258716

**Winterization**

**Rail Transit Winterization Technology and Systems Operations Study**

Proj. MA-06-0025  
Kusko, Inc.  
September 1980, PB 81-122-905

**Energy**

**Cost-Effectiveness Model Development for Energy Storage Devices in Rapid Transit Systems**

Proj. PA-06-0059



D. Sunstein and R. Uher  
September 1980, PB 82-101-163

**Comparison of Transit Car Energy Consumption Measurements with Computer Model Predictions**

Proj. MA-06-0025

V. Nene  
In Process

**Energy Cost Reduction Study of the Washington Metropolitan Area Transit Authority Metrorail System**

Vol. I, Final Report

Proj. DC-06-0315

R.A. Uher and A. Sathi

May 1982, PB 83-115378

**Energy Cost Reduction Study of the Washington Metropolitan Area Transit Authority Metrorail System  
Vol. II, Appendices**

Proj. DC-06-0315

R.A. Uher, A. Sathi, and N. Sathi

May 1982, PB 83-115-386

**Power Rate Structure Aspects of Energy Cost for Rapid Transit Systems**

Proj. PA-06-0059

R.A. Uher and O.N. Sharma

June 1982, PB 260118

**Energy Use in Ground Transportation**

Proj. MA-06-0153

Booz, Allen and Hamilton, Inc.

In Process

***Electromagnetic Interference (EMI) and Compatibility (EMC)***

**Chopper Induced Interference in Audio-Frequency Automatic Train Control Systems**

Proj. MA-06-0025

University of Lowell

March 1980, UMTA-MA-06-0025-80-5

**Effects of the Metropolitan Dade County Rapid Transit System on the Electromagnetic Environment**

Proj. MA-06-0025

Radiation Sciences

August 1980, UMTA-MA-06-0025-80-10

**Harmonic Characteristics of Rectifier Substations and their Impact on Audio-Frequency Track Circuits**

Proj. MA-06-0025

V. Nene

May 1982, PB 82-229659

**Status of Advanced Propulsion Technology in Japan**

Proj. MA-06-0025

V. Nene

In Process

**Electromagnetic Interference Characteristics of Advanced Propulsion Systems for Urban Rail Vehicles**

Proj. VA-06-0075

V. Nene

February 1981, PB 81-212-730

**Statistics of Chopper Interference on Multi-Car Trains**

Proj. MA-06-0025

University of Lowell

February 1981.

**Recommended Practices for Rail Transit Intra-System Electromagnetic Compatibility of Vehicular Electrical Power and Track Circuit Signalling Subsystems**

**Vol. I, Inductive Recommended Practices**

**Vol. II, Conductive Recommended Practices**

Proj. MA-06-0025

Transportation Systems Center

May 1982

**CONSTRUCTION TECHNOLOGY**

***Contracting and Management***

**Economic Factors in Tunnel Construction**

Proj. MA-06-0025

E. Foster, et al.

February 1979, PB 294-726

**Management of Urban Construction Programs**

**Vol. I, Guidelines for Development of Project Management Plans**

**Vol. II, Supplemental Information**

**Committee on Management of Urban Construction**

Proj. MA-06-0100

National Research Council, Building

Research Advisory Board

June 1981, PB 81-242-380,398

***Elevated Structures***

**Investigation of Design Standards for Urban Rail Transit Elevated Structures**

Proj. GA-06-0010

Harrington, George and Dunn, Inc.

June 1981, UMTA-GA-060-0010-81-1

***Track and Wayside Technology***

**Interaction and Load Transfer Through Track Support Systems**

**Parts I and II**

Proj. OS-80013

University of Arizona

September 1982

**Pilot Study for Definition of Track Component Load Environments**

Proj. MA-06-0100

Kaman Avidyne

February 1981, PB 81-203-531

**Technical and Economic Feasibility Study of At-Grade Concrete Slab Track for Urban Rail Transit Systems**

Proj. MA-06-0100

Amir N. Hanna

August 1981, PB 82-113-812

**U.S. Transit Track Restraining Rail  
Vol. I, Study of Requirements and  
Practices**

**Vol. II, Guidelines**

Proj. MA-06-0100

Ensco, Inc.

October 1981, UMTA-MA-06-0100-81-6

***Underground Structures***

**Field Evaluation of Advanced Methods of  
Geotechnical Instrumentation for Transit  
Tunneling**

Proj. MA-06-0100

Bechtel Corporation, Haley and Aldrich

March 1983

**Design Recommendations for Concrete  
Tunnel Liners**

Proj. MA-06-0100

University of Illinois

February 1983

**Development of an Extruded Tunnel Lining  
System**

Proj. MA-06-0100

Foster Miller Associates, Inc.

March 1983

**The Atlanta Research Chamber: Applied  
Research for Tunnels (Monographs)**

Proj. GA-06-0017

Don C. Rose, et al.

March 1981, PB 81-231-151

**Potential for Standardization in Rail  
Transit Tunnel Construction**

Proj. DC-06-0182

Delon Hampton Associates

August 1979, PB 80-108-699

**Mechanical Tunneling in Solid Rock:  
Final Translation**

Werner Rutschmann

May 1980, PB 80-221-013

**Field Evaluation of Advanced Methods of  
Subsurface Exploration for Transit  
Tunneling**

Proj. MA-06-0100

D. E. Thompson, et al.

June 1980, PB 80-200-496

**Urban Tunneling Technology Program  
Digest**

Proj. MA-06-0100

Transportation Systems Center

April 1980, PB 81-165-219

**Improved Design of Tunnel Supports  
Executive Summary**

PB 80-134-547

**Vol. I, Simplified Analysis of  
Ground-Structure Interaction In Tunneling**

PB 80-225-154

**Vol. II, Aspects of Yielding  
in Ground-Structure Interaction**

PB 80-225-162

**Vol. III, Finite Element Analysis of the  
Peachtree Center Station in Atlanta**

PB 80-225-170

**Vol. IV, Tunneling Practices in Austria  
and Germany**

PB 80-225-188

**Vol. V, Empirical Methods in  
Rock/Tunneling: Review and  
Recommendations**

PB 80-225-196

Proj. MA-06-0100

Massachusetts Institute of Technology

June 1980

**Conceptual Study of Handicapped  
Facilities for New Subway Station  
Designs**

Proj. DC-06-0182

Delon Hampton Associates

September 1980, PB 81-178-485

**Segmented Concrete Tunnel Liner and  
Sealant Systems**

Proj. MA-06-0100

Water and Power Resources Service

July 1980, PB 81-105-843

**Effects of Tunnel and Station Size on the  
Costs and Service of Subway Transit  
Systems**

Proj. CA-06-0116

Jet Propulsion Laboratory

April 1979, N80-19989/6

# New Systems and Technology

---

## Trends and Highlights

Not all transit improvements can be expected to evolve directly from conventional modes of service. General advancements in technology and innovations in related fields of transportation are a continuing source of opportunities for potential cost, safety and service improvements in public transit. The people movers currently operating at a number of airports, college campuses, amusement parks and other activity centers in the U.S. are one such source of new technologies. These systems employ driverless vehicles on exclusive guideways and have proved to be reliable and popular modes of transportation. They use a wide variety of innovative propulsion, guideway and automatic control techniques.

UMTA's program in these technologies is known as the Advanced Group Rapid Transit (AGRT) Program. In the past, the AGRT Program concentrated on systems analysis and the development of operational test tracks to demonstrate automated guideway transit system concepts. During FY 82, AGRT activities were shifted to focus on the important subsystems and components which have application not only to automated guideway systems, but also to conventional rail systems.

Other new technology projects currently underway include the testing of an accelerating walkway and a concentrated effort to find technological solutions to the paralyzing problems caused by severe cold weather.





# Advanced Group Rapid Transit (AGRT)

The concept definition phase of UMTA's Advanced Group Rapid Transit Program was completed in August 1975. Three contractors—Boeing Aerospace Co., Otis Elevator Co., and Rohr Industries—produced competing preliminary designs. Boeing's system concept included use of rubber-tired vehicles driven by rotary traction motors. The Otis concept employed an air-cushion suspension system operating in conjunction with linear induction motor propulsion. The Rohr concept included use of magnetically suspended and propelled vehicles.

In June 1979 contracts were awarded to Boeing and Otis (WA-06-0011, CO-06-0011). Critical technology elements of the Boeing and Otis concepts are included in the current AGRT program. The Rohr magnetic levitation/propulsion effort was continued by Boeing, which acquired rights to the Rohr concept under license.

The specific objectives of the current program are 1) reduction of economic and technological risks associated with development of critical technology, 2) development of standards of performance and design for selected critical subsystems and 3) development and testing of subsystems.

Technologies which are being emphasized and which have broad applications to transit include: onboard collision avoidance sensors, fault-tolerant vehicle control equipment, and power conditioning equipment for control of linear induction and AC propulsion motors.

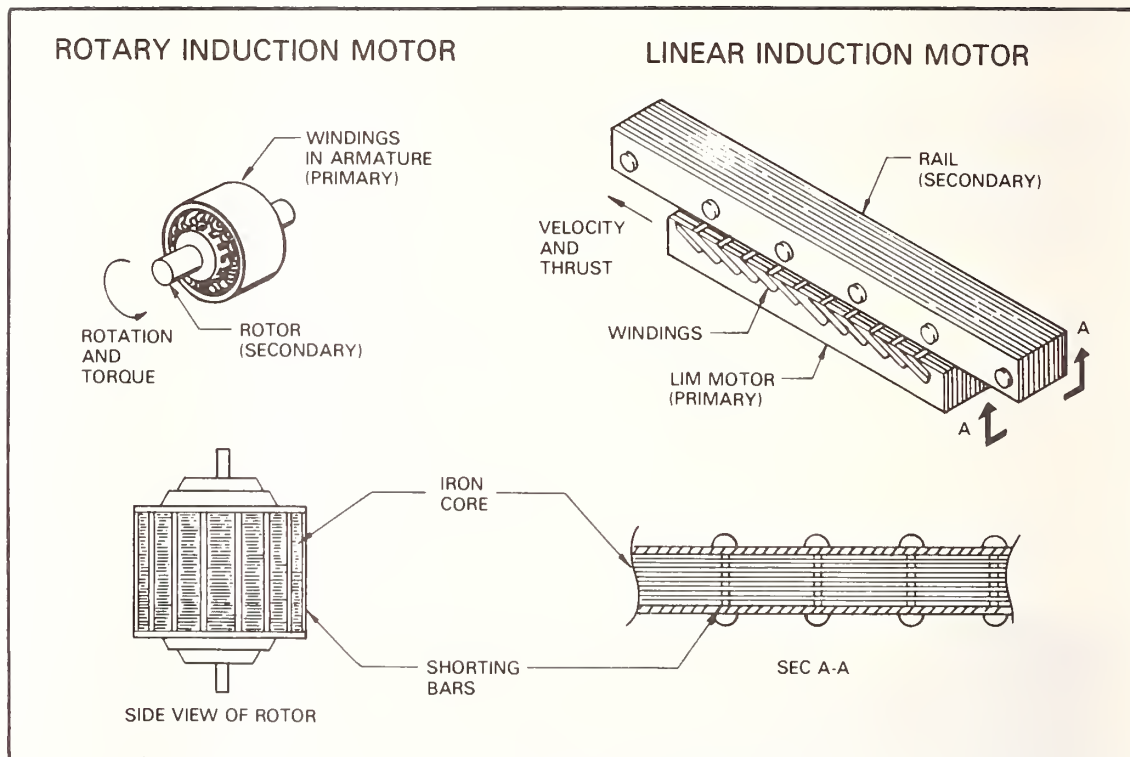

*The linear induction motor is analogous to a regular motor but is spread out horizontally and has no moving parts.*

*Magnetic levitation vehicles are powered by linear induction motors. These motors provide propulsion, braking, and guidance, as well as levitation.*



## Other Projects

### Accelerating Walkways

Work on accelerating walkways was carried out through a grant to the Tri-State Regional Planning Commission. Accelerating walkways are devices capable of transporting large numbers of pedestrians over short distances. A typical accelerating walkway moves at something less than normal walking speed for boarding and unloading, but increases to more than twice the normal walking speed for the main portion of the trip.

An accelerating walkway feasibility study was completed in FY 81 (IT-06-0126). The study provided a comprehensive overview of accelerating walkway technology, identified potential applications and associated cost benefits, and provided an independent safety assessment. Phase II study contracts were completed by four contractors: Ateliers et Chantiers de Bretagne (ACB), Boeing Aerospace Co., Dean Research Corp. and Dunlop Transportation Systems, Ltd. The contracts covered design documentation, analytical studies, and preliminary demonstration studies. Phase III, which provides for acquisition of test and operational data, is currently underway in France, using a walkway manufactured by ACB.

### Cold Weather Transit Technology Program

In the aftermath of the major operational difficulties experienced by transit systems during the winter of 1978, Congress became increasingly concerned with the inability of transit systems to operate efficiently under conditions of cold, snow and ice. Nearly one-third of the nation's

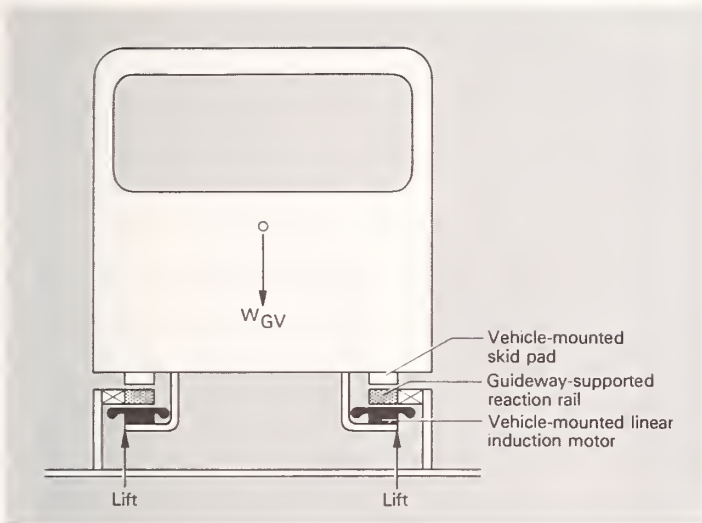

*Magnetic levitation eliminates contact between vehicle and guideway thus reducing construction, operating, and maintenance costs. Reliability is improved since ice and snow, for instance, do not impede operations.*



*This test stand is used for evaluating both the propulsion and levitation properties of linear induction motors.*





***Sophisticated models of bus feeder systems, developed for automated guideway systems, are being applied to conventional bus-rail services.***

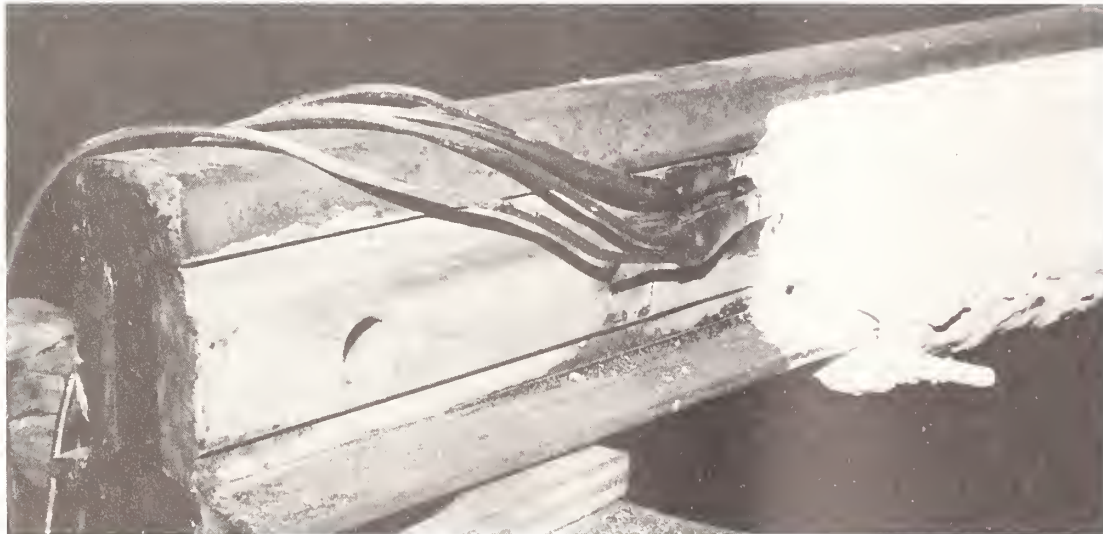

***Foam insulation is being applied to the third rail heater in an attempt to improve the heater's ice melting capability and reduce its energy consumption.***

transit systems suffer from interruption and limited or cancelled operations in severe winter weather.

Recognizing the need for fundamental research and development activity to address this problem, Congress appropriated \$5.5 million in FY 80 for the prompt initiation of research to advance cold weather transit technology, and an additional \$5.5 million in FY 81 to continue the program now scheduled for completion in late 1983. Congress also directed that the program be conducted by the University of Notre Dame in Indiana, and was in favor of pursuing the program proposed by the Vought Corp. in Texas. The program involves evaluation of high pressure water field testing, low frequency radiation laboratory testing, and other methods of removing ice and snow from third rails. Other tests include switch heater, third rail tests and traction motor snow ingestion prevention. The successful identification of the cause of rail pull-aparts for continuous welded rail, along with the recommended solutions, is a direct result of this program. The final report is scheduled for late 1983 (IN-06-0009).



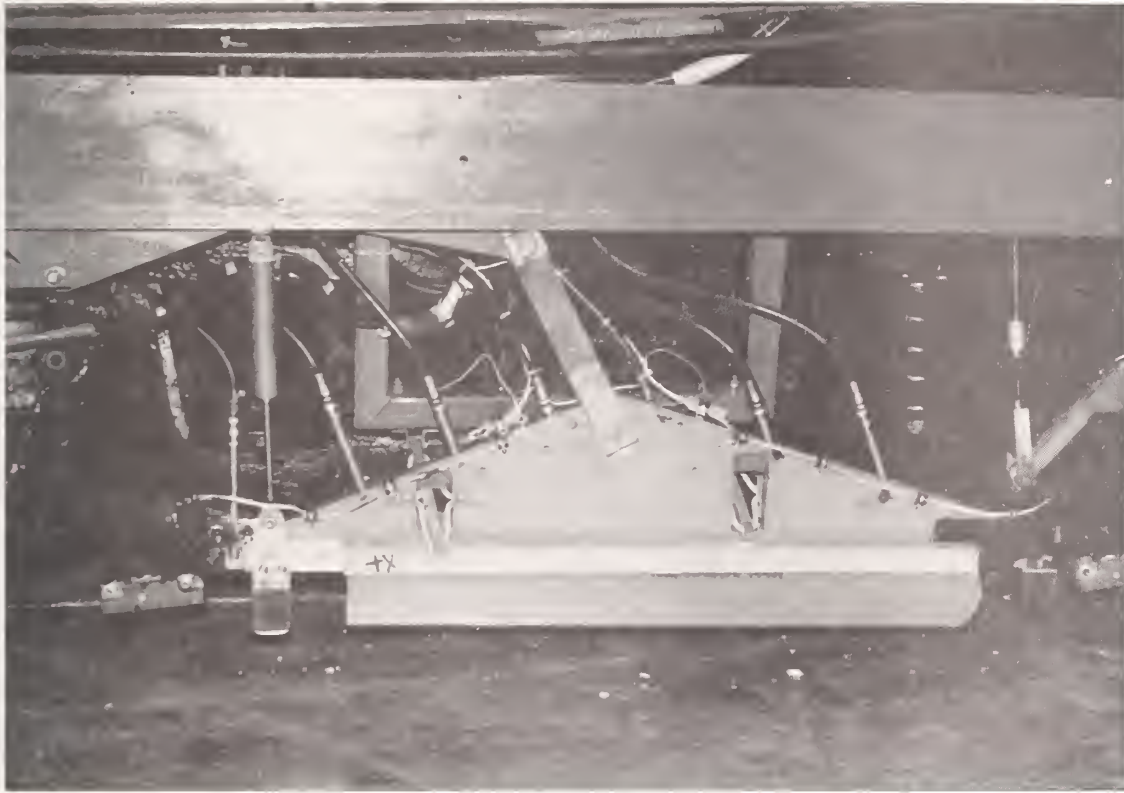

*This experimental third rail ice remover, being tested in Boston, uses high pressure water to blast off ice and glycol to prevent ice reformation.*

## New Systems and Technology

| PROJECT TITLE   | NUMBER     | FUNDING      | SCHEDULE                  | AGENCY/<br>CONTRACTOR  | TECHNICAL<br>CONTACT               |
|---|------------|--------------|---------------------------|--|------------------------------------|
| <b>ADVANCED GROUP RAPID TRANSIT</b>                     |            |              |                           |  |                                    |
| Phase IIB AGRT<br>Development                           | WA-06-0011 | \$28,082,000 | Sept. 1979-               | Boeing Aero-<br>space Co.;<br>Otis Elevator Co.  | Robert Hoyler<br>(202) 426-0090    |
|   | CO-06-0011 | \$25,248,000 | Sept. 1985                |  |                                    |
|   | WA-06-0014 | \$3,939,000  |                           |  |                                    |
| Technical Studies<br>in Guideway and<br>Vehicle Systems | VA-06-0186 | \$1,026,000  | Sept. 1978-<br>Sept. 1983 | MITRE Corp.  | Robert Hoyler<br>(202) 426-0090    |
| Technical Studies<br>in Safety and<br>Dependability     | IT-06-0190 | \$712,000    | July 1979-<br>Oct. 1983   | Battelle Columbus<br>Laboratory  | Robert Hoyler<br>(202) 426-0090    |
| Technical Studies<br>in Command and<br>Control          | MD-06-0047 | \$975,000    | Aug. 1979-<br>Dec. 1982   | Johns Hopkins<br>University, Applied<br>Physics Laboratory                                       | Robert Hoyler<br>(202) 426-0090    |
| Technical Studies in<br>Magnetic Levitation             | VA-06-0067 | \$186,000    | Oct. 1980-<br>Sept. 1983  | MITRE Corp.  | Robert Hoyler<br>(202) 426-0090    |
| <b>OTHER PROJECTS</b>                                   |            |              |                           |  |                                    |
| Accelerating Walkways                                   | IT-06-0126 | \$3,386,000  | Aug. 1976-<br>Sept. 1983  | Tri-State Regional<br>Planning Commission,<br>N.Y.; Port Authority<br>Of New York and New Jersey | Robert Hoyler<br>(202) 426-0090    |
| Cold Weather<br>Countermeasures                         | IN-06-0009 | \$11,000,000 | Jan. 1980-<br>Oct. 1983   | University of<br>Notre Dame  | Jack M. Anderson<br>(202) 426-6371 |

### Bibliography

A list of recent reports follows. Please consult previous editions of this Directory for earlier reports. If available, a document number assigned by the National Technical Information Service (NTIS) is listed. Reports may be obtained from NTIS by using the order blanks provided at the end of this document.

Reports which have not been assigned an NTIS number may not have

been published in sufficient quantity for general distribution. Single copies and other information may be available from the issuing agency or organization.

Additional reports relating to the research described in this chapter may become available in the near future. For the most recent information or suggestions for additional reference materials regarding specific projects, call or write to the person listed as the technical contact in the Project Summary Table.

### ADVANCED GROUP RAPID TRANSIT (AGRT)

#### Factors Contributing to the Retention of Seated Passengers During Emergency Stops

Proj. MA-06-0048  
Dunlap and Associates  
March 1980, PB 80-195-134

#### Passenger Value Structure Model

Proj. MA-06-0048  
University of Virginia  
July 1980, PB 81-120-875

**Predicting Automated Guideway Transit System Station Security Requirements**

Proj. MA-06-0048

W. V. Rouse and Company  
March 1980, PB 80-194-244

**AGT Guideway and Station Technology Vol. I, Executive Summary**

PB 299-553

**Vol. IV, Design Guidelines**

PB 295-613

**Vol. V, Evaluation Models**

PB 299-034

**Vol. VI, Dynamic Model**

PB 299-153

**Vol. VII, Guideway and Station Concepts**

PB 299-411

**Vol. VIII, Weather Protection Concepts**

PB 299-746

Proj. IT-06-0152

DeLeuw Cather and Company  
1979

**Systems Operation Studies for Automated Guideway Transit Systems: Summary Report**

PB 81-101-693

**Classification and Definition of**

**AGT Systems**

PB 80-226-509

**Representative Application Areas for AGT**

PB 81-154-551

**Plan for Task 5, DPM Failure Management**

PB 81-210-569

**Feeder System Model (FSM) Functional Specifications**

PB 81-233-496

**System Availability Model User's Manual**

PB 81-233-504

**Availability Model Functional Specification**

PB 81-233-512

**System Availability Model Programmer's Manual**

PB 81-233-520

**Detailed Station Model Functional Specification**

PB 81-233-538

Proj. MA-06-0048

General Motors Corporation  
1980 and 1981

**Passive Vehicle Automated Guideway Transit—Documentation of Previous Work and Assessment of Impact of New Technology on This Concept**

Proj. TX-06-0030

Vought Corporation

August 1980, PB 81-117-079

**Morgantown People Mover Redundant Computing System Design Summary**

PB 81-151-367

**Electromagnetic Compatibility Program**

PB 81-148-082

**Collision Avoidance System Design Summary**

PB 81-154-858

Proj. MA-06-0048

Boeing Aerospace Company  
September 1980

**AGT Aesthetics: A Handbook for Planning and Design of Automated Guideway Transit (AGT) Systems**

Proj. IT-06-0165

Skidmore, Owings and Merrill

February 1980, PB 80-173-594

**An Analysis of the U.S. Market for Automated Guideway Transit Vol. I, National Market Estimates**

PB 81-228-793

**Vol. II, Urban Area Case Studies**

PB 81-228-801

**Vol. III, Consumer Attitudes**

PB 81-228-819

Proj. IT-06-0165

Cambridge Systematics, Inc.  
November 1980

**Automated Guideway Transit Socioeconomic Research Program: Findings, 1976-1979**

Proj. IT-06-0176

MITRE Corporation

February 1980, PB 80-184-633

**Automated Mixed Traffic Transit (AMTT) Market Analysis**

Proj. VA-06-0056/DC-06-0197

MITRE Corporation and SRI International  
September 1980, PB 80-121-148

**Assessment of Operational Automatic Guideway Systems: Airtrans (Phase II)**

Proj. MA-06-0069

Transportation Systems Center and  
Institut de Recherche de Transports,  
France

January 1980, PB 80-182-538

**Interim Assessment of the VAL Automated Guideway**

**Transit System**

Proj. MA-06-0069

Transportation Systems Center

July 1981, UMTA-MA-06-0069-81-3

**Summary of Capital and Operations and Maintenance Cost Experience of Automated Guideway Transit Systems: Costs and Trends for the Period 1976-1979**

Proj. MA-06-0069

Transportation Systems Center

March 1980, PB 80-204-878

**Cost Experience of Automated Transit Systems**

Proj. MA-06-0069

Transportation Systems Center

July 1981, PB 81-245-656

**OTHER PROJECTS**

**Executive Summary, Cold Weather Transit Technology**

**Vol. I**

Proj. IN-06-0009



University of Notre Dame  
In Printing

**Physics in Ice and Snow at the Interface  
with Transit Surface**

**Vol. II**

Proj. IN-06-0009

University of Notre Dame  
September 1981

**Characteristics of Ice and Snow at the  
Interface with Transit Vehicle Surface**

**Vol. III**

Proj. IN-06-0009

University of Notre Dame  
September 1981

**Advanced Countermeasures for  
Controlling Ice and Snow Problems**

**Vol. IV**

Proj. IN-06-0009

University of Notre Dame  
September 1981

**Transitway Design Concepts for Improving  
System Performance Under Cold Weather  
Conditions**

**Vol. V**

IN-06-0009

University of Notre Dame  
September 1981

**Planning for a National Cold Weather  
Transit Technology**

**Vol. VI**

Proj. IN-06-0009

University of Notre Dame  
September 1981, PB 83-134684

**Lightweight Transit Vehicle Traction  
Performance on Ice and Snow**

**Vol. VII**

Proj. IN-06-0009

University of Notre Dame  
April 1982, PB 82-256488

**Development of Transitway  
Countermeasures for Controlling Ice  
and Snow Problems**

**Vol. VIII**

Proj. IN-06-0009

University of Notre Dame  
April 1982, PB 82-256496

**Development of Vehicle Countermeasures  
for Controlling Ice and Snow Problems**

**Vol. IX**

Proj. IN-06-0009

University of Notre Dame  
April 1982, PB 82-257387

# Service and Methods

---

## Trends and Highlights



The purpose of UMTA's Service and Methods Demonstrations (SMD) is to improve the quality and efficiency of urban transportation by sponsoring the implementation of new transportation management techniques and innovative transit services. The program focuses on strategies that utilize existing transportation technology to provide improvements requiring relatively low levels of capital investment and able to be implemented in a short time frame.

During the past year, with the increased pressure on local budgets and the search for cost-effective alternatives to fixed-route transit, there has been considerable interest in the outputs of the SMD program. A nationwide training and technical assistance program was begun to inform transit operators and planners about methods for improving the efficiency and economics of transportation services. The response to this program has been excellent, and it is expected that the scope of information dissemination efforts will be expanded in the next few years.

SMD continued its ongoing efforts to test and document transportation innovations. An evaluation of taxi regulatory changes was completed during the past year. Many cities are contemplating changes in their local regulatory structure, and significant interest is anticipated in this area.

Several transportation pricing alternatives are being tested, including self service fares, automatic fare collection, and a variety of transit pass alternatives. Test results will allow transit operators to maximize farebox revenues without adversely affecting ridership.

On-site demonstrations of several of the successful SMD projects are being

held in their "host" cities. The HOST Program was designed to give local government officials an opportunity to learn first hand how to implement their own projects.

## Transportation Services for Special User Groups

The term "special users" refers to those members of the population who, because of age, income or disability, are dependent upon public transportation or other special arrangements to meet their transportation needs. In addressing the problem of transportation for elderly and disabled persons, it has become evident that there is no single solution for every individual or locality. Thus, a range of service options has been tested, evaluated and documented. Local officials now have at their disposal information on a wide range of approaches, from which they can select the ones most suited to their particular environment.

Transit buses equipped with lifts to provide access for wheelchair users and others who cannot use steps are now in operation throughout the United States, in cities with widely varying characteristics. The early technological problems which prevented consistent operation of the lifts have been surmounted, but costly maintenance, problems of service reliability, and low ridership characterize many of these services.

The qualified success of the accessible fixed-route services is counteracted by the number and variety of paratransit programs being conducted. These range from user subsidy programs to transportation

brokerage systems. The private transportation provider, whether taxi, van operator or private nonprofit provider, has emerged as a key participant in specialized paratransit services. Emphasis is now being placed on enhancing paratransit service productivity.

With the reduction in many human service agency budgets, the efficient use of transportation funds becomes even more imperative. Coordination of funding and services in urban areas is being demonstrated in a number of ways. These efforts involve such things as interagency referral of transportation information, joint purchasing arrangements, and consolidation of equipment and transportation services. Some agencies can now purchase transportation from other providers to serve their clients. In other efforts the local transit authority acts as a broker, matching the demand for special services with available supply from both public vehicles and private companies.

### Coordinated Services for the Elderly and Handicapped

In many cities and regions, special transportation services for the elderly and handicapped are provided or funded by a variety of social service agencies and organizations. Often the agencies in a particular locality are not as a whole making the most efficient use of their transportation resources. Meanwhile many elderly and handicapped people, particularly those not affiliated with any social service agency, remain unserved. Experienced transportation providers such as taxi operators are often overlooked when new services are established.

A coordinated transportation program,

utilizing public and private transportation firms in conjunction with social service agencies, could provide at least a partial solution to the problem of limited mobility still experienced by millions of elderly and handicapped Americans living in cities.

UMTA has been experimenting with systems to bring about a more coordinated approach to transportation services in a number of localities of varying sizes. These include consolidating services under one central provider, developing multifunded neighborhood-based paratransit, and an approach in which a transportation broker matches individual and agency needs with the most appropriate provider.

One such project in San Diego, Calif., (CA-06-0134) has developed a comprehensive plan to coordinate and consolidate the transportation resources of social service agencies and other providers in San Diego County. In an effort to create an acceptable implementation plan, a unified approach has been developed to include the resources of the California DOT and the metropolitan planning agency. The project will make an inventory of existing resources and present several alternatives for coordinated areawide services.

A planning project (RI-06-0012) conducted by the Rhode Island DOT will design a new organizational model for a statewide coordination center. A brokerage function will seek to facilitate the efficient use of all public and specialized service within the state through incremental coordination.

### User Subsidy Demonstrations

Another approach which UMTA has fostered to improve transportation for the





***The cost-effectiveness of several taxicab contracting and service approaches is currently being evaluated.***

elderly and handicapped in various cities is to directly subsidize the cost of trips purchased by those users, rather than subsidize the transportation providers. In this manner, a city can choose for whom and at what level to subsidize transportation. User subsidies in the form of discounted rates for bus or taxi fares through the use of tickets or voucher systems have been tested by UMTA in a number of cities.

The most recent user subsidy demonstration was approved for San Diego, Calif. (CA-06-0170), to test the feasibility of using this concept as the catalyst for

coordinating social service transportation services. Agencies will purchase ride tickets from the city and distribute them to their clients according to their own criteria. The tickets can then be used on vehicles owned by any eligible provider. Administrative, operational and service aspects of the project will be evaluated. This is also an example of a large city converting an existing dial-a-ride to a user side subsidy.

#### **Other Activities**

A grant was awarded to the International City Management Association

(ICMA) in conjunction with the National League of Cities (NLC) to prepare readings, articles and other information dissemination pieces on cost-effective ways of providing transportation for handicapped persons (DC-06-0393). These articles and readings will be broadly distributed to ICMA and NLC membership.

In June of 1981, a contract (IT-06-0274) was awarded to provide technical assistance to designated state and local areas in the planning of improved transportation services for handicapped persons. This project is designed to help local agencies help themselves, and to fulfill UMTA's objective of improving mobility for handicapped persons through the dissemination of information on the best practices. The program will aid service centers and providers in assisting handicapped people to achieve independent living status more easily.

A study has been conducted on the costs and ridership of specialized transportation services as well as of accessible fixed-route services (VA-06-0076). While this study did not generate any new data, it brought together most existing information on the subject. This will assist transit operators and city officials in determining what services they can afford to provide when meeting current and future regulations and legislation.

In September 1982 a contract was awarded (DC-06-0417) to investigate the extent of volunteer use in transportation programs for the elderly and handicapped. A grant was also made in September to the Vera Institute of Justice (NY-06-0096) to plan a demonstration of rides to work for handicapped persons. This grant, matched by IBM, is one of a number of private/public sector initiatives.

During 1980 a project was funded in Bridgeport, Conn. (CT-06-0010), to improve the mobility of residents of an inner-city neighborhood on the city's east side. One of the objectives of the project is to encourage active participation by neighborhood residents in both the planning and operation of the service. The details of the service design are dependent on the results of market research in the community to determine needs for both internal community circulation and employment travel. Emphasis will be placed on modifying existing services and improving information rather than implementing entirely new services. Through its ongoing brokerage demonstration, the Greater Bridgeport Transit District will also integrate east side paratransit needs with other services sponsored by the transit district, such as shared-ride taxis, special services for the elderly and handicapped, ride sharing and conventional buses.

## Fare and Pricing Policies

The main objective of exploring variations in fare pricing policies is to increase transit ridership and revenues, and to reduce operating costs. Current pricing research examines the impact of fare and service strategies directed toward particular market segments that have a high potential for increased ridership.

Information on fare incentives helps specify marketing strategies that stimulate the private sector to share the cost of transit and carpools. Fare incentives can promote ride sharing and provide alternatives to subsidized parking. Other public/private co-ventures are being examined

with the aim of facilitating transit improvements, generating additional revenues and improving service productivity.

Transit fare prepayment techniques, applied through programs sponsored by employers and merchants, help to penetrate specific markets. Such diversification requires improved fare collection techniques. More comprehensive fare policies that also simplify collection and distribution of revenues are needed. In addition, conventional transit pricing strategies are being used to analyze the integration of paratransit services through transportation brokerage.

By clarifying the impacts of fare and service changes on demand and revenues, guidelines for planning for fare variations can be provided to the transit industry. This is done through seminars for general managers and board members in which the results of operational and research experience in multi-modal pricing and related service improvements are discussed.

### Promotional Fare Incentive Strategies

It has been generally recognized that fare reductions can promote additional transit ridership. The nature of the fare reduction and the characteristics of the ridership market are important determinants of the effectiveness of the fare incentives. Past demonstration and evaluation projects have provided information regarding the costs and benefits of fare incentive programs.

In this past year additional results were obtained from two downtown fare free zones in Albany, N.Y. (NY-06-0064), and Knoxville, Tenn. (TN-06-0006-1). These projects have shown remarkable

ridership increases by tripling pre-fare free levels. A major impact of fare abolitions was an increase in the frequency of individual transit trips by different groups. In Albany, it was possible to assess the effect of improving downtown mobility on retail economic activity. The study indicates that downtown retail sales increased by approximately 10 percent while countywide sales decreased by 3 percent. The greatest impact on retail sales occurred for merchants located on transit routes and during the Christmas season.

One of the major findings of the fare free demonstrations was that a certain proportion of new riders is retained following the termination of free service. It is not known, however, how long a fare reduction period is needed to attract and retain new riders. In all the demonstrations, the ridership increases occurred within the first three months. The question of whether this period is sufficient to engender a long-term change in transit users' habits is being addressed in ongoing demonstrations and evaluations. Also being explored is the question of whether sufficient additional revenue accrues to compensate for promotional price reductions.

A technical support study (PA-06-0056) is providing technical assistance in a demonstration to show that public/private cooperative efforts can increase transit revenues and also enhance economic stability.

### Transit Fare Prepayment (TFP) Options

Transit fare prepayment programs can be an effective means of implement-



ing fare policies for managing transit demand and cost. Most transit properties offer some form of prepaid fares, but transit operators have only recently begun to actively promote transit fare prepayment strategies. The interest in the initial Service and Methods Demonstration (SMD) projects on TFP strategies involving reduced price promotion and employer programs has provided a basis for identifying new opportunities for TFP programs targeting specific markets.

The employer-sponsored TFP demonstrations in Sacramento, Calif. (CA-06-0102), and Jacksonville, Fla. (FL-06-0016), made possible the targeting of employer-initiated TFP promotions to employees. There are now final reports available for these projects. The Sacramento demonstration has been amended to test a variety of TFP distribution systems designed to make them more easily available to current and potential users. Pass sales were the highest when the pass was reasonably discounted by the transit operator or the employer. Pass sales tripled during the discount period, with about a 50 percent retention of new pass purchasers. There was an approximate 10 percent transit ridership increase among employees. The cost of the program among participating employers, estimated at approximately 50 cents per pass sold, was considered marginal compared with the benefits received. During these demonstrations the transit community expressed great interest in the results and operational aspects of the program. Many transit systems across the country have initiated employer-sponsored fare prepayment plans. The SMD projects are assisting local agencies and employers to plan and implement these programs.



***Different methods of distributing monthly passes, stamps, and ticket books are being evaluated in Sacramento. (This project is included in the Host City Program. Project personnel are available to explain their results to the transit community.)***

A manual of the implementation and marketing procedures of employer pass programs has been developed (VA-06-0072) based on several case studies of local programs. Written for board members and other community leaders, transit operators and staff, and interested employers, the manual delineates the promotional, operational, and cost/benefits of these employer co-ventures. The logistics of program implementation and maintenance are specified, accompanied by marketing and accounting materials.

TFP programs appear to have a potential for penetration into various localized markets. A demonstration in Tucson, Ariz. (AZ-06-0009), has provided an opportunity to test the effectiveness of TFP instruments in increasing transit ridership among university students. By marketing transit to students, local officials expect to relieve traffic congestion in the vicinity of the campuses and to lessen the demand for campus parking spaces. Results show appreciable increases in semester and monthly discount pass sales, which have



in turn resulted in peaking of transit ridership along routes to and from the campus. An extension of this project is testing the impact of a two-tier pricing system for the semester pass and 20-ride ticket books. Passes and tickets which are valid only during the off peak are priced lower than the all day passes and tickets.

Discounted TFP instruments are being tested for differential pricing during peak hours to make rush hour ridership more evenly distributed. The Transit Fare Prepayment/Staggered Work Hour Program in Duluth, Minn. (MN-06-0013), encouraged workers in the central business district (CBD) to use available transit services for their work trips. The program initially offered monthly transit passes to employees participating in staggered work hours or flexitime programs. Special discounted monthly passes, restricted from the 7:00 a.m. to 8:00 a.m. rush hour period, were available only to CBD employees. The principal objective is to increase CBD-oriented transit work trips without overburdening transit facilities during the morning rush period. Beginning in August 1981, the program was opened to the general public. Two types of monthly passes were available: a discounted pass valid at all times except on buses scheduled to arrive downtown between 7:30 a.m. and 8:00 a.m., and an unrestricted pass. Formal demonstration activities ended in 1982. Initial results show that variable work hour programs are difficult to implement if there is not a widespread perception of congestion caused by peak demand. Differential pricing by time of day, using fare prepayment, should be considered only if TFP has extensive market penetration. The length of the restricted period should be as long as possi-

ble to minimize the number of riders able to take advantage of the discount without changing their travel behavior.

TFP's are also being used to promote fare integration among different carriers and agencies. A major problem in the acceptance of TFP for fare integration is the revenue distribution among the parties involved, as well as the political and institutional process of bringing together many different operators in multi-jurisdictions.

San Francisco, Calif., has studied

transit fare prepayment in order to encourage intermodal/interagency coordination (CA-06-0137). The primary objective of this study is to develop a uniform fare structure for all modes and operators in at least one part of the San Francisco Bay Area, so that the concept of intermodal/interagency fare coordination can be evaluated in an operational environment. A fare prepayment instrument was used to enable transit patrons to transfer between modes or operators without having to pay



***A study in the San Francisco area has evaluated the implementation of a uniform fare structure for different modes and operators supplying the same transportation network.***

an additional fare. Fares varied according to distance traveled, regardless of which modes or lines within the combined network were used. The study of fare integration options has been completed and SMD will continue to monitor the program and report the results to the transit community.

In Atlanta, Ga., an evaluation has been completed (GA-06-0012) on the impact of integrated intermodal fare collection and fare prepayment methods on transit users, and the operations of the Metropolitan Atlanta Regional Transit Authority. A "TransCard" pass is used in the integrated bus/rail system. The fare structure in use is a single fare payment at a flat rate for completion of the entire transit trip regardless of the number and mode of transfers required. A barrier free transfer between bus and rail is included. Recently a weekly pass has been introduced to limit the impact of a fare increase on low income people. In Bridgeport, Conn. (CT-06-0008), and Scranton, Pa. (PA-06-0055), new TFP strategies are being tested. In Bridgeport, a "Farecutter" card can be purchased for \$15 per month. With the card, patrons have unlimited use of transit at only 25 cents per trip, as opposed to the usual charge of 60 cents. A commuter pass is also available at \$23 per month, good only during rush hours. It is expected that the additional trips taken over and above the break-even trip rates will generate sufficient revenue to compensate the operator for pass discounts and promotions.

In Cincinnati, Ohio (OH-06-0036), a locally instituted monthly pass plan will be evaluated to determine the costs of implementing such a program at a site without previously existing TFP plans. Prelimi-

nary results are giving a clear picture of the specific costs associated with setting up and operating a pass program. These results will enable transit operators to decide whether anticipated pass program benefits such as shorter boarding times, more rapid revenue collection, pricing flexibility and user convenience outweigh the cost of administration and marketing. In addition, a methodology for pricing fare prepayment plans will be developed and tested.

### **Fare and Service Management Strategies**

While the pricing demonstrations are indicating the kinds of fare incentives and fare payment strategies required to increase ridership and better manage revenue producing transit markets, more information is needed regarding fare policy decision making as it relates to service levels.

In a demonstration in Vancouver, Wash. (WA-06-0010), scheduling changes to provide shorter headways and better utilize bus capacity have increased ridership by up to 40 percent. A 10 cent fare increase after the headway change reduced ridership by only 5 percent. The marginal loss of ridership due to the fare increase suggests that fare changes at higher service levels are more inelastic. During the second phase of the project, two separate transit components are being evaluated for their effect on transit ridership: service expansion and a revenue producing fare structure. The fare structure component was designed to establish break-even fares on new extended routes, and in the event that break-even fares were not marketable, promotional

fare reductions would be instituted to determine a marketable fare. Initial results indicated that the break-even fares could not attract ridership by themselves. Service modifications and fare incentives were introduced that stimulated ridership growth for premium service. Costs of the route extension have remained constant so the additional premium revenues improved the financial productivity of the service. Further service variations for the express service are planned. These may provide such significant service differentials in comparison with local service that the break-even fares may be able to cover costs.

In Knoxville, Tenn., a package of fare incentives was implemented to promote increased use of ride sharing and transit to the downtown (TN-06-0006). The fare incentives included a downtown fare free zone, merchant validation of shoppers' fares, and integrated taxi/fixed-route fares. The fare incentives were able to persuade employers and merchants to join a city-sponsored program by contributing to the users' cost of ride sharing. Ridership has approximately tripled in the downtown area with numerous employees participating in ride-sharing programs and 23 merchants participating in the shoppers' validation promotion. The integrated taxi/fixed-route service was not successful in attracting sufficient trips to cover contract costs and was eliminated after a three month test. The new approach will be tested in another suburban Knoxville area where there is more retail activity. The number of line-haul transit buses will be reduced and smaller vehicles operated by taxi or van companies substituted. The system will be augmented by other vehicles which will circulate within the area.



Within a set of fare increase case studies, the relationships between the impact on ridership of the additional fare and the quality of service have been assessed. The results provide a more realistic analysis of fare increase elasticities. Evaluation reports of the impact of fare increases in Fort Worth, Tex., Newport, Ky., Rochester, N. Y., Erie, Pa., and Jacksonville, Fla., are available.

Another completed study for planning fare changes provides a guide to developing, interpreting and using fare elasticity information in evaluating fare increases by transit planners. The study stresses the importance of monitoring and using local time series data for the analysis.

A study (PA-06-0054) is being conducted of fare policy decision making within the transit community. The study's objective is to prepare an industrywide profile of how transit systems currently develop and implement fare policies. Reflecting a cross section of the transit industry, twelve transit systems have been selected because of their fleet size and composition, service area size and complexity, and sources of local funds. The case studies will focus on the policy considerations that enter into fare changes.

A demonstration underway in Bridgeport, Conn. (CT-06-0008), is demonstrating the effectiveness of a variety of concepts designed to increase the service, patronage, and efficiency of the public transportation services. The activities which comprise the Bridgeport program are similar to those which should theoretically be conducted by public transportation agencies. The primary difference is that the demonstration framework in Bridgeport permits more extensive plan-

ning, monitoring and evaluation than would be found in the typical system.

The pricing aspect of the program is designed to exemplify the role of the pricing manager and show the potential benefits of having at least one individual in a transit operation whose full time duties relate to tailoring the price of transit and paratransit to specific services and markets. The pricing demonstration enumerates specific projects which the pricing manager is to undertake, or in which he/she is to be involved. The pricing manager is a functional resource available to all elements of the Greater Bridgeport Transit District (GBTD), providing specialized advice and assistance on the pricing aspects of all GBTD actions. Specific pricing initiatives implemented in Bridgeport so far include a distance-based fare prepayment system for commuter service, nondiscounted pass and token sales with promotional coupons for merchant discounts ("Value Fare"), and employer subsidized passes for employees.

Attempts at experimentation with fares and services have focused on separate independent experiments in either pricing strategies or service improvements. The lack of an integrated approach to the coordination of fares and services has resulted in a number of missed opportunities for increasing patronage while staying within the bounds of deficit or subsidy constraints. These opportunities arise from the fact that while transit demand is inelastic with respect to both fares and services, service elasticities are generally two to three times greater than fare elasticities.

Although a service improvement may not be self-financing, it may be possible to cover the marginal cost through relatively

small fare adjustments, i.e., by a combination of fare increases or decreases, and service improvements or reductions.

Data drawn from 40 months operating experience on the San Diego (Calif.) Transit Corporation bus system were analyzed. The study used only the same kind of operating statistics that transit authorities normally assemble in the course of their operations. The analysis showed that it is possible to use this information in more sophisticated ways in order to obtain more precise relationships—as, for example, to assess patronage as a function of level of service. As more transit operations adopt computerized transit information systems, such analyses can be made more easily.

Two demonstrations, in Omaha, Neb. (NE-06-0003), and Columbus, Ohio (OH-06-0027), have begun to implement a computerized information system providing periodic updates on service delivery, operating revenue data, and patronage characteristics. The computerized system will use techniques and results developed within the SMD program and the transit community for effecting service and fare policy decisions in medium-sized cities.

In the first phase of the Omaha effort, the computerized data base will be used to integrate analysis among different productivity levels for service, maintenance and patronage. In the second phase, existing computerized techniques developed by other offices in UMTA and elsewhere will be integrated with data bases developed in the first phase. A final report is expected by late 1983.

In Columbus, the first phase has produced productivity criteria and performance measures related to a set of transit board approved goals and objectives for



transit service delivery. An extensive data base has been developed with current information on ridership, costs, and revenues. The second phase, now in progress, will examine each element of the transit service to see if it meets the approved standards, and alternative improvements will be developed for those routes which do not. In addition, three innovative productivity enhancement models will be tested and applied to Columbus Ohio Transit Authority's (COTA) service planning process. A comparison of the different approaches to productivity improvement will be made along with a before/after assessment of changes actually implemented, to determine if predicted impacts have occurred. A computerized data base management system also will be tested in the second phase.

### Fare Collection Techniques

The method of fare collection is a primary determinant of the fare policy a transit system can implement. Because systemwide fare policies are giving way to fare policies targeted at specific user groups, it is becoming more important to develop fare collection techniques capable of handling a wide diversity of fare structures.

In Santa Cruz, Calif., a complex automatic fare and data collection system is being developed that will accommodate a zonal fare system with a variety of prepayment options and contract billing for employees at local businesses. Future phases of this project (CA-06-0157) will include wayside vending of tickets and a complete self-service fare collection system.

Self-service fare collection, which has



*This is an example of European self-service fare collection systems which are now being considered by some U.S. systems.*

met with wide success in European transit systems, is being considered by several U.S. transit properties. The issues of fare structure flexibility, evasion, costs, implementation procedures and hardware requirements will be examined closely during the demonstrations of several variations at different sites. These variations will include different levels of hardware use, driver involvement in the fare collection process, and methods of determining fare compliance.

Flat fare structures are often depicted as being inequitable to transit users and inefficient in producing revenues commensurate with service provided. Distance based fare structures, on the other hand, pose problems with administration and fare collection. A cooperative agreement is being developed with the State University of New York in Albany (NY-06-0086), to implement a distance-based fare structure in a transit system and to analyze its impact on costs and revenues, ridership, and user equity. The new fare policy will more accurately reflect the service provided. A fare collection procedure will be tested that simplifies the collection of the variable fares characteristic of distance based systems. The transit system of Ulster County, N.Y. is being considered as a test site, and the actual implementation of the new fare structure is scheduled for the summer of 1983.

In Vancouver, Wash. (WA-06-0010), onboard pass sales for premium express fixed-route service were tested. Pass sales and express transit use increased appreciably.

In Portland, Oreg. (OR-06-0008), an extensive program of self-service fare collection is currently in operation. This system of fare collection features all door

boarding, with each passenger responsible for purchasing and validating the proper fare instrument (single ticket, multiple ride ticket or pass). Fare inspectors are empowered to fine transit riders who cannot exhibit proper fare documentation. Initial results show a significant drop in fare evasion and a high degree of acceptance by transit riders.

San Diego, Calif., has begun operating a light rail transit line using self-service fare collection. This operation is being evaluated in terms of vending machine performance and public acceptability (CA-06-0158). This study will examine the first U.S. implementation of self-service fare collection and will provide valuable information for other cities. A final report is expected by the fall of 1983.

### **Auto Management Techniques**

It is generally acknowledged that automobiles occupied by only the driver making work trips are a primary contributor to traffic congestion, air pollution and energy waste in urban areas. By restricting the use of single occupant auto work trips through control of parking capacity as well as pricing, it should be possible to increase the efficiency of the existing transit system and reduce the negative impact of automobile use. The use of pricing disincentives in these programs can make them financially self-supporting and a source of funds for other transportation improvements.

A Parking Management and Employee Incentive Program in Los Angeles, Calif. (CA-06-0140), developed the administrative and legal framework for a coordinated program of reduced parking for private sector businesses in exchange

for employer sponsored work trips in high occupancy vehicles. Another study, the Van Nuys (Calif.) Employee Transportation Program (CA-06-0139), developed a comprehensive parking management plan for a large office complex. Preliminary findings indicate a large potential for expanding commercial development in central city areas, particularly where lower cost rehabilitation of older structures is now possible due to reduced parking facilities.

Pricing of the work trip through increased parking charges may be an effective method of encouraging ride sharing and use of existing transit services. A preliminary evaluation of the increase in federal government parking charges to half the prevailing commercial rate appears to show an increase in the average car occupancy in a sample of federal parking facilities in Washington, D.C. (IT-06-0233).

In Madison, Wis., a morning peak hour surcharge at several city-owned parking facilities has been operated in conjunction with express bus service from several fringe parking lots, and a program of discounted monthly bus passes offered to CBD employees (WI-06-0006). The primary objective was to increase the availability of short-term parking in the CBD during the day. Preliminary results indicate that the surcharge does pay for the increased cost of parking attendants and increases the supply of mid-day parking.

The use of residential parking permits is an effective technique commonly used to restrict commuter parking in residential neighborhoods. This technique is being applied in two recreational settings to test its effectiveness in controlling parking and traffic congestion caused by nonresident users of the recreational facility. Such programs are designed to be financially self-





*Various auto management incentives, aimed at promoting better use of our highways and transit systems, are being evaluated by UMTA.*

supporting with revenue from the sale of nonresident permits paying for alternative shuttle bus service and parking enforcement.

In Santa Cruz, Calif., the program (CA-06-0129) had its second full summer of operation in 1982. The program was well supported by residents of the restricted zone but drew some opposition from non-residents and businesses. The shuttle bus system was underused and

viewed as inconvenient. Changes made in the demonstration for 1982 included elimination of shuttle bus service and reduction of the restricted zone. Results of the 1982 program show that the permit program can be financially self-supporting by using permit and citation revenues and through careful allocation of personnel and program hours.

In Hermosa Beach, Calif. (CA-06-0126), the 1982 summer program con-

tinued to experience some difficulty due to inadequate signposting and inconveniently located permit sales outlets. It is expected that the 1983 summer program will correct these limitations.

Another pricing disincentive technique, road pricing, is being considered in Honolulu, Hawaii (HI-06-0004). An initial workshop was held to adopt a plan for developing publicly acceptable alternative road pricing strategies. This technique appears to generate interest in areas suffering from acute traffic congestion and few options for alleviating the problems caused by extensive use of low occupancy autos. A consulting firm has been selected to carry out the research and consensus building among interested groups necessary for the development of feasible alternative road pricing options.

### **Private Sector Involvement**

There has been a major growth of private sector interest in actively participating in public transportation demonstration projects supported by UMTA. A similar interest has been documented for private sector participation in capital intensive joint development transit projects. However, the data from demonstration projects indicate that the private sector's interest in public transportation extends beyond local capital investment strategies to the provision of community-based public transportation accessibility in order to promote business activities.

In particular, employers have initiated ride sharing and transit pass distribution programs for the benefit of their employees, as a means of reducing commuting costs, alleviating parking shortages and costs, and providing a reliable supplement



to auto travel in view of an energy uncertain future. Merchants have initiated promotional transit incentives to attract off peak retail patronage. Land developers are implementing local ride sharing and transit circulation service to reduce the costs of zoning-regulated parking space. Private operations are emerging for paratransit and premium fixed-route services that are near break-even or profitable. These and other innovative approaches to private sector involvement have been documented within SMD demonstrations and local initiatives. By pulling together private sector experience from past and ongoing demonstrations, the SMD program plans to study comprehensive approaches to private sector involvement. Previous discussions have already dealt with innovative ways for providing promotional fare reductions with employer and merchant assistance (Scranton, Pa.), reinforcing continual off peak transit use with merchant discounts (Spokane, Wash.), having merchants finance downtown fare free zones that increase retail sales (Albany, N.Y.), initiating employer pass programs (Sacramento, Calif., Jacksonville, Fla., and Duluth, Minn.), targeting special user groups such as students (Tucson, Ariz.), enhancing transit and ride-sharing options with employer assistance (Knoxville, Tenn., Santa Cruz, Calif., and Los Angeles, Calif.) and reducing fare collection costs through private enterprises (Sacramento, Calif.).

Other private sector participation activity currently underway includes demonstrations in Hartford, Conn. (CT-06-0014), and Denver, Colo. (CO-06-0013). The local private ride-sharing agency in Hartford is providing the means for developing a Transportation Management Organization

to coordinate transportation system improvements in the downtown, and another private group will establish a transportation management entity to assess and develop new techniques for resolving the transportation problems in downtown Denver.

## Marketing Techniques

Programs in marketing were designed to develop and demonstrate transit marketing techniques for improved system productivity, and to assist transit operators in understanding and successfully applying these techniques.

The Transit Marketing Information Exchange Project (IT-06-0238) is an ongoing project designed to 1) facilitate the exchange of existing transit marketing material within the transit community, 2) plan a clearinghouse for the material and 3) eliminate excessive expenditures of time, effort and money on the part of transit operators in the investigation of state-of-the-art programs and techniques.

A project with the Birmingham-Jefferson County Transit Authority (AL-06-0008) is designed to conduct an innovative marketing program and to design paratransit services for various sections of the system. This project will be exploring various marketing techniques needed for ridership enhancement.

In an effort to test the effectiveness of various marketing techniques in small cities, a grant was awarded to the Arkansas State Highway and Transportation Department (AR-06-0002). This project will explore a wide variety of marketing promotional techniques as applicable to the marketing of fixed-route public transit ser-

vices in cities of less than 20,000. The grantee will explore the advantages and disadvantages of having a single operator institute and market, in one overall marketing plan, fixed-route public transit programs in three separate but adjacent cities.

The objective of a grant to the Western Reserve Transit Authority (OH-06-0038) is to conduct a management assessment of the authority and to implement an innovative marketing program to enhance ridership. The project is designed to address peak and off-peak service planning and means of increasing adult, senior and youth ridership. In addition, Saturday ridership enhancement development will be explored. Micro-computer design will be utilized in developing marketing models.

A project with Dellingham Associates, Inc. (IL-06-0050) will develop a Transit Awareness Survey to assess the level of consumer awareness concerning the role and contributions of the transit industry. The primary goal of the project will be to reinforce and broaden the growing public support for transit by promoting a clear understanding of the role transit plays both as a public service and as a function of national policy.

## Conventional Transit Service Innovations

The cost of providing transit service has increased significantly over the past decade, due largely to higher fuel and labor costs. Transit agencies around the country are facing financial crises. As a result, they are cutting service, raising fares



and, in a few scattered cases, closing down completely.

Service and Methods Demonstrations have focused renewed attention on those techniques that will aid transit agencies to reduce costs. There has been a shift of emphasis away from projects involving the introduction of new transit services toward projects that are designed to improve productivity on existing systems. Most notable in the area of productivity improvement are two Computerized Rider Information System projects. These projects will test the feasibility of a computerized information system to attract new riders to transit. Other efforts directed toward improving productivity include studies of articulated buses, timed transfer systems and route restructuring.

### **Auto Restricted Zones**

The auto restricted zone (ARZ) is an area, generally in the central business district, in which vehicle traffic is restricted. An ARZ can be created through the use of either parking restrictions, barriers to traffic, or prohibition of all automobile traffic. Three ARZ projects (Boston, Mass., Memphis, Tenn., and Providence, R.I.) have been constructed or are in the final stages of planning.

An ARZ was developed in Boston to demonstrate the feasibility of the concept. In this program, limited street space was partially restricted in the downtown shopping district to better serve the needs of pedestrians, transit services, merchandise shipment, taxis and private autos. Evaluation of the project indicates that the program has been well received by pedestrians, the media, transit patrons, and most merchants. The anticipated major

*UMTA evaluated a transit center in a Portland, Oregon suburb where local feeder routes are integrated with regional trunk lines at timed intervals (Host City Program participant).*



traffic tie-ups on the periphery of the zone did not materialize.

A grant (TN-06-0008) was awarded to conduct and evaluate a program that combines the development of an ARZ with improvements to the Memphis transit system. These improvements will include the upgrading of transit stops, development of a downtown transit terminal, and institution of a high frequency, low fare shuttle bus service between the downtown ARZ and the highly populated medical center. A parallel purpose of this grant is to support the downtown revitalization program which began with a locally sponsored pedestrian mall.



*Since 1978, Boston has restricted automobile use in one of its oldest and most important central retail areas (Host City Program participant).*

The city of Providence, R.I., plans to develop an ARZ in conjunction with the revitalization of the central business district (CBD) and transit service improvements. An UMTA grant (RI-06-0010) of \$960,000 out of \$5 million required for the total project was awarded to Providence in 1978. With goals similar to those sought in Boston's ARZ program, the city will construct a large pedestrian plaza. In addition, transit service improvements will be made, including a revamped bus routing system to allow routing through the CBD, and the construction of a major 12-berth downtown bus terminal and a small transit mall. Construction for the ARZ and transit

improvement project is scheduled to begin in 1983.

A study conducted by Pennsylvania State University (PA-06-0073) will evaluate the impact of auto restricted zones that have been implemented throughout the U.S. The study will give a picture of how these zones have functioned over time.

### **Priority Treatments for High-Occupancy Vehicles**

Many groups and individuals have voiced concern over the need to reduce government expenditures. This concern has led federal, state, and metropolitan governments to develop plans for encouraging the use of public transportation and carpools while maximizing the use of existing roadway systems. SMD has funded a variety of techniques to attract people to public transit. One of the most effective strategies has been to improve transit services by giving preferential treatment to buses and carpools, both on major highways and on city streets.

To assist in the implementation of preferential treatment strategies, a planning manual for high-occupancy vehicle priority facilities was published. The manual, developed for SMD by the Urban Consortium, has had a good reception and is being used by local planners and by many universities as an instructional aid. On the whole, however, implementation of recommended strategies has been slow, partly due to lack of funding.

Several SMD projects to facilitate the use of high-occupancy vehicles have been initiated in recent years in Houston, Tex., St. Louis, Mo., and Philadelphia, Pa. The Houston Corridor Improvement Project (TX-06-0018) is being implemented by the city of Houston as one of a number of



coordinated improvements in the city's transportation system. The major activity in this project was the construction of 10 miles of contraflow lanes for public transit vehicles on the North Freeway. Park-and-ride lots accommodating 2400 vehicles were established. Transit priority treatment for another Houston corridor, the Katy Freeway, is still being planned.

The St. Louis CBD Transit Priority Project (MO-06-0010) will focus on simplifying the transit route structure in the CBD along with providing reserved curb lanes and adjusted signal timing to facilitate the movement of buses.

The Philadelphia project (PA-06-0053) includes the provision of signal preemption for trolley buses along Frankfort Avenue. This project will also provide additional overhead trolley wire to accommodate 50 peak period express trips.

I-66 in the Northern Virginia suburbs of Washington, D.C. is being constructed to standards of a four-lane parkway. Use of the road is limited during the peak period to vehicles carrying four or more persons. There is a significant improvement in travel time and reliability for these vehicles. The changes in transportation service and public reaction to it will be evaluated (DC-06-0402).

A project in South Lake Tahoe, Calif. (CA-06-0180), will test a model to merge school bus service with transit. A unified system, as opposed to two separate systems, should serve both markets more efficiently.

In Brevard County, Fla. (FL-06-0036), the Brevard County Transportation Authority is improving commuter service by enlisting the support of private employers in providing express bus and vanpool service. This will allow the county to enjoy



*In Houston, Texas, the contra-flow bus and vanpool lane has significantly reduced travel times for these high-occupancy vehicles and has led to substantial increases in ride-sharing and transit use in the I-45 corridor (Host City Program participant).*

the benefits of transit service without incurring the costs of providing the service with full-time employees.

The private sector will play a larger role in providing transit service in a Palm Beach, Fla., area project (FL-06-0034). This service will be directed primarily at intercity commuters not usually served by local transit service. The project will develop a reasonably priced alternative to the automobile, capable of operating on a continuing basis.

A new management tool, Automated Vehicle Monitoring (AVM), has been developed to locate buses and automatically

collect a variety of data from them. An AVM system has recently been developed at the Southern California Rapid Transit District (SCR TD) in Los Angeles. An SCR TD project (CA-06-0171) will develop improved methods of using this AVM system. Anticipated benefits include collection and analysis of data for scheduling, real time reliability control, driver monitoring and emergency calls.

### **Transit Reliability**

SMD sponsored a transit reliability project (MN-06-0011) in Minneapolis-St. Paul, Minn., which began in FY 79. The

purpose of this project was to test the hypothesis that improved transit reliability can be realized without a significant increase in operating costs or other adverse effects. This project is expected to demonstrate the effectiveness of schedule changes in improving reliability.

Rensselaer Polytechnic Institute (NY-06-0097) is conducting a study of bus service reliability techniques that will be tested through the demonstration program. These techniques, which include improved use of street supervisors and better real time management of buses, should be inexpensive and easy to implement.

In another demonstration (VA-06-0079) an inner-city transit improvement is proposed for the Newport News-Hampton, Va., area. Several routes operated by Penntan are being redesigned to serve the suburban shopping centers now emerging as important destinations of inner-city residents.

### Transit Information

A major demonstration (PA-06-0058) is underway in Erie, Pa., where a Computerized Rider Information System (CRIS) will be tested. CRIS will allow potential patrons to call a telephone number and receive a taped message about the arrival time of the next bus at any bus stop in the system. Similar demonstrations are planned for Pittsburgh, Pa. (PA-06-0066), Albany, N.Y. (NY-06-0092) and San Rafael, Calif. (CA-06-0184). Evaluations are also being conducted of locally implemented projects in Salt Lake City, Utah and Columbus, Ohio.

Under the Automated Transportation Information System (ATIS) Program, dem-

onstrations were completed on two computerized systems for responding to telephone inquiries about the availability of transit services. These ATIS systems are now in successful daily operation at WMATA and SCRTD. A final report evaluating their effectiveness is in preparation and will be available in FY 83 (MA-06-0126).

## Paratransit Services

Paratransit as a service concept has apparently come of age and begun to receive growing attention as an accepted part of the urban transportation network.

The recognition that one kind of transportation service cannot serve all markets and that services must be designed to meet the needs of particular market segments is one important reason for the growing interest in paratransit. Another reason is the need to make better

use of existing transportation resources in both the public and private sectors. UMTA's Service and Methods Demonstrations (SMD) Paratransit Program is designing service models to show how these resources can be used in a coordinated fashion to serve markets more effectively than is possible under conventional fixed-route systems.

During FY 82, steady progress toward larger, more comprehensive projects has been made in the paratransit area. Attention has focused on effective brokerage arrangements under which a mix of transportation services are coordinated to serve both the general public and special user groups. In addition, regulatory studies have been conducted to examine different environments which have facilitated private sector involvement in providing paratransit services.

In spite of such progress, however, many problems remain. Labor agreements require time consuming negotiations, and these agreements sometimes place restrictions on service. This is not a problem as far as the demonstrations are concerned, but could affect the flexibility of future paratransit operations. There have been difficulties, too, in attempting to integrate the private taxi industry with public transit.

Nonetheless, the paratransit demonstrations discussed in this chapter show that positive changes can be made in the approach to transportation problems.

### Integration of Paratransit and Fixed-Route Systems

UMTA has conducted a number of demonstrations to show how paratransit can supplement and complement fixed-

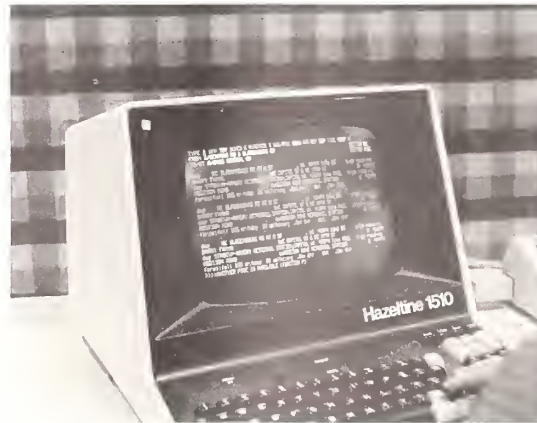

*The Automated Information Directory System at WMATA develops itineraries for customers who call the agency. The itineraries are displayed to the telephone operator on a CRT screen.*



route transit service. Notable among these was a project in Rochester, N.Y., using demand-responsive service to improve area coverage of the city and its environs and provide special services for the elderly and handicapped.

The most significant development of the project was a computerized dispatching system for demand-responsive vehicles. Another positive development was the specialized service for the elderly and handicapped, which was continued after the demonstration and had been expanded countywide. A third important innovation was the use of a private transportation company to provide demand-responsive service in two suburban towns.

However, all demand-responsive service available to the general public has since been discontinued because the local governments did not want to subsidize it, even though the service would have been less expensive than fixed-route service in the same areas. For the most part, the areas formerly having demand-responsive transportation now have no service at all, or are served by fixed-route transit which pre-dated the demonstration.

Under another project (CA-06-0097) the software perfected in Rochester, N.Y., is being applied in Orange County, Calif., which has developed a program to provide community demand-responsive service. The software system is currently being used for dispatching in two service areas and will eventually be used throughout the entire county.

Two other projects are examining the effects of using taxis as feeders to fixed-route bus service in a low density area. These projects, which began operating in San Diego, Calif. (CA-06-0165), in July

1982, and will begin in Memphis, Tenn. (TN-06-0013), in early 1983, will measure the cost of the feeder service compared to conventional fixed-route operations and will test the willingness of the public to use the feeders and transfer to and from line haul routes. If enough demand develops, it may be possible to substitute fixed-route service for the feeder service.

A demonstration project (FL-06-0023) to integrate a complex of transit and para-transit services was initiated in Dade County, Fla., late in FY 81. Major elements of the project include a range of para-transit services such as taxi feeder service to fixed-route transit, low density community service contracted with a taxi operator, and taxis substituting for fixed-route service during off peak hours. The project will also strengthen coordination of social service agency transportation in the county. A major component will be a computer-assisted routing, scheduling, dispatching and management information system which is currently being developed through another UMTA grant. In conjunction with the demonstration, the county has adopted extensive changes in the taxi regulatory climate which should enable the taxi industry to provide innovative taxi service. A final element of the project is to coordinate county commuter ride-sharing services.

The Port Authority of Allegheny County (PAT) is conducting a design study for a demonstration of service for suburban and low density areas under funding granted late in FY 82 (PA-06-0074). Para-transit options for serving areas which cannot be covered economically with conventional transit will be explored. Improvements to existing bus routes will also be considered.

## Transportation Brokerage

Transportation brokerage has become a widely accepted means of improving transportation services, especially in small and medium sized communities, and has gained new prominence in large cities. A public transportation broker views the transportation system as a variety of markets which are matched with both existing and new services. Brokerage has proved to be an effective means of involving private transportation providers in the system.

Differences in urban areas require variations in transportation brokerage models. Depending upon existing circumstances, the broker's duties include contracting with private operators, modifying existing transit services, establishing car-pool and vanpool programs, and coordinating social service agency travel. The broker acts as coordinator and tries to implement more efficient use of existing vehicles.

The projects described below were specifically designed to demonstrate the concept of transportation brokerage. The planning phase of a large city transportation brokerage project (MO-06-0012) has begun in St. Louis, Mo. The project will include brokerage of commuter ride sharing, special services for the elderly and handicapped (including a user subsidy program) and general transportation information and referral. This demonstration will apply the brokerage concept, which has been successful in smaller urban areas, to a major city with a complex institutional and regulatory setting.

In another demonstration (IL-06-0038), the Regional Transportation Authority (RTA) in Chicago, Ill., is functioning as



broker, coordinating a range of paratransit services for communities in the suburban Chicago area. Based on the needs of the individual communities, these services include shared-ride taxi, taxi feeder to fixed-routes, subscription bus service, and special services for the elderly and handicapped.

The paratransit services are funded and given technical and management assistance by the RTA. Both private and public operators provide the actual services. The last of the six SMD sponsored demonstration projects there was completed during 1982. There are now over 30 paratransit projects in the continuing RTA program.

The Pittsburgh Paratransit Broker Demonstration (PA-06-0042), completed in FY 82, was designed to coordinate paratransit services for elderly and handicapped people in the Pittsburgh, Pa., metropolitan area through the use of a broker. PAT selected a private firm to serve as the broker, whose primary function is to insure the availability of all necessary dispatching and transportation resources, to provide a mechanism for the flow of funds, to market the system actively, and to monitor the entire system.

The project gave all social service agencies and individual elderly and handicapped consumers the opportunity to buy the services of a unified paratransit system at ride-sharing rates. Allegheny County is divided into service sectors for which providers bid. Elderly and handicapped users who are not affiliated with an agency are subsidized through a PAT user subsidy program.

A project in Bridgeport, Conn. (CT-06-0008), is demonstrating a systemwide brokerage approach to planning, imple-



***The ACCESS program provides the elderly and handicapped with door-to-door service in Allegheny County, Pennsylvania (Host City Program participant).***

menting and operating a variety of transit and paratransit services in both the public and private sectors. The Greater Bridgeport Transit District (GBTD) is operating the fixed-route transit system and working in other areas such as ride sharing, coordination of social agency transportation, taxi/transit integration, suburban and inner-city community transit service, and economic development. Examples of new services the GBTD has developed to meet the needs of various market segments in the community include the Fairfield Minimover and the Human Services Transportation Consortium.

The Fairfield Minimover provides both

peak hour commuter service and daytime circulation routes to one community within the district. The Consortium, which was formed with assistance from the GBTD, is now an independent entity that coordinates the paratransit services provided by a group of social agencies and towns. The GBTD has also begun working actively with private taxi operators and city and business leaders to initiate a user subsidy for the elderly and handicapped and to explore the possibility of shared-ride taxi service for the general public.

A demonstration of ride-sharing brokerage in the Newport News-Hampton, Va., area (VA-06-0050), completed in FY 82, involved working with

local employers to stimulate interest in ride sharing. The project analyzed employee work trip data and developed ride-sharing strategies to best suit the employment site. These included carpools, vanpools, subscription bus, and changes in scheduled transit service. A related brokerage function coordinated the use of vans among social service agencies.

### **Checkpoint Demand-Responsive Services**

The checkpoint concept provides the promise of productivity improvements over traditional demand-responsive service by reducing dwell times and/or by grouping passengers. The service operates as demand-responsive services have in the past except that vehicles stop only at designated checkpoints instead of taking passengers from door-to-door, thereby increasing productivity. It appears particularly suited for low-demand, low-density areas. The concept has been applied successfully in Europe utilizing sophisticated computerized equipment. Two demonstrations were funded to test the operational feasibility of the concept in the United States. In both Glendale, Ariz. (AZ-06-0013), and in a six-city subregion of the Twin Cities area in Minnesota (MN-06-0015), consultants were hired to conduct final feasibility studies and design detailed implementation plans. During 1982, the consultant's final report for the Twin Cities project recommended a manually dispatched route deviation checkpoint concept, which the local communities may or may not implement. In Glendale, manually dispatched checkpoint service was implemented in one service area during 1982. Other ser-

vice areas are under consideration for expansion. Unless demand increases significantly, computerization is not anticipated.

### **Other Paratransit Innovations**

Widespread adoption of computer ride-sharing programs by both private and public sectors highlights an increased interest in low-cost alternatives to fixed-route bus service. Due in large part to successful SMD demonstrations, information on the range of alternatives is now available to local decision makers as they face critical choices on the future of local transportation services. The following studies undertaken under the paratransit program are intended to provide planning and technical assistance to paratransit operators or to test other promising paratransit innovations.

The California DOT is conducting a feasibility study and project design of a demonstration of shared use of motor vehicles in large, high-density residential complexes (CA-06-0166). This project is exploring the feasibility of utilizing a fleet of vehicles of various sizes and types by a large group of people at a site such as a large apartment complex or condominium. The vehicles would be owned either by a third party or a condominium association and users would be charged only for the actual costs of their use of fleet vehicles. This would enable users to choose the most suitable vehicle for any particular trip—for example, a van for commuting, a subcompact for errands, a large sedan or a recreational vehicle for family vacations. Participants in the project would no longer need more than one vehicle to meet their traveling needs and might be able to forego owning a car altogether. A shared

vehicle system would serve as an effective substitute for a fixed-route transit service, especially in suburban locations where transit is unable to provide cost-effective service.

Purdue University Research Foundation is also exploring shared fleet approaches to urban mobility in a project funded late in FY 82 (IN-06-0012). This study focuses primarily on the application of the concept to neighborhood transportation, particularly in enterprise zones.

A related project involving transportation cooperatives is being conducted by Transporting the Handicapped and Elderly in Massachusetts (THEM, Inc.) (MA-06-0148). The project is planning the formation of a cooperative funded by a minimum of five major Boston employers, to establish employee ride-sharing programs, redeploy ride-sharing vehicles for off-peak human service trips, explore the feasibility of integrating shared-ride taxi as a cooperative resource, and develop a computerized billing and accounting service for each member.

The city of Huntsville, Ala. (AL-06-0007), is developing neighborhood transportation services utilizing volunteers. Under the demonstration, the city is giving used 15-passenger vans to neighborhood associations to help meet local transportation needs. These volunteer-operated services are directed principally at the transportation disadvantaged, such as elderly persons, and at others, such as school children, without adequate transportation. The city provides the vans and insurance, while the neighborhoods are responsible for operating the vans. The city views the service as the most cost-effective means of providing transportation to these communities. It is able to provide a higher



level of service at a lower cost than is possible with fixed-route bus service.

A demonstration in the San Francisco, Calif., area (CA-06-0163) will implement a back-up system to the existing ride-sharing program operated by the Golden Gate Bridge, Highway, and Transportation District. The project will test the feasibility of attracting additional commuters to ride sharing by having a back-up system available. A sizable number of commuters are reluctant to ride share because of the possibility that they may occasionally work late or have other variations in their work

schedule. Back-up vans will be driven by commuters who currently have unusual work hours such as 10:00 a.m. to 7:00 p.m. Drivers will receive a free ride and riders will pay a per trip fee based on round-trip mileage.

A second component of the project will be the establishment of a Project Information Coordinator to test innovative approaches to disseminating information and providing technical assistance to other communities. A set of information dissemination strategies are being developed to increase information flow.

A project has been implemented by the Los Angeles County Transportation Commission (CA-06-0184) to establish a local technical assistance office. With the passage of Proposition A, local jurisdictions within the county are examining service options for implementation in their community. The technical assistance office will be utilizing the recently developed SMD Short Range Planning Guidelines to provide advice and information on the wide range of alternatives developed and evaluated through the SMD program. The project will also evaluate the impact of the fare decrease mandated under Proposition A.

Projects in San Diego, Calif. (CA-06-0127), and Seattle, Wash. (WA-06-0019), evaluated the impact of recent regulatory reforms affecting the local taxi industry. The revisions eased entry requirements, implemented competitive pricing, and allowed competition with fixed-route public transit. The project focused on the taxi industry, users, institutional issues, and impacts on the urban transportation system. A project in Boston, Mass. (MA-06-0144), is studying the feasibility of implementing shared-ride taxi services for the general public. The study is concentrating on a pilot neighborhood and is examining institutional and regulatory barriers, fare structure, driver and user acceptance, and dispatching problems.

A project in Ann Arbor, Mich. (MI-06-0028), is demonstrating the feasibility of contracting with private taxi operators to provide service during late night hours when conventional transit is uneconomical. Door-to-door taxi service is provided by a city-licensed taxi operator with dedicated vehicles within the city limits of Ann Arbor from 11:00 p.m. to 6:00 a.m. Rider-



*The Golden Gate Ridersharing project has developed a back-up system for commuters who must work late (Host City Program participant).*



ship and productivity reached impressive levels in the first six months of service, while passenger subsidies were low.

## Rural Transportation

Activities undertaken in this area are designed to explore the long neglected transportation needs of non-urbanized communities throughout the nation. Projects are structured to assess all aspects of rural transportation, including regulatory, cooperative, paratransit and marketing issues, as well as implementation feasibility.

Another project (DC-06-0406) will assess the applicability of the cooperative concept to rural transportation needs and determine the feasibility of using alternative methods in a coordinated manner to enhance the development of passenger transportation schemes within the rural community. The project will also examine and build upon existing private sector initiatives, and upon institutional resources that combine passenger service with the hauling of freight, mail delivery and the movement of consumer goods.

The Tuskegee, Ala., transportation assessment study (AL-06-0010) will explore the transportation needs of Tuskegee with regards to specific user needs and service area requirements. This project will also assess the negative impact that lack of adequate transportation has on its citizens in such areas as employment, health care and social functioning. In a related effort (MD-06-0093), SMD is developing a rural transportation data base. The project is designed to coordinate and review all existing transportation elements in 2-3 rural areas of Alabama, Florida,

Georgia and Kentucky. The project will review both local and state regulatory issues and explore private sector employment ventures.

A project in Fayette, Miss. (MS-06-0004), is demonstrating the ability of a single fleet of paratransit vehicles to service a low-density, highly impoverished county. The needs of Jefferson County citizens will be met by a combination of fixed-route, subscription and demand-responsive services.

A joint agency project with the Department of Agriculture (DC-06-0392) is examining the potential for passenger development in conjunction with the movement of freight. In addition to freight/passenger service, the project will study the potential uses of existing or new cooperative organizations, the availability of existing private or public vehicles, and the impact of intercity bus deregulation on rural passenger transportation needs.

## Service and Methods

| PROJECT TITLE   | NUMBER     | FUNDING   | SCHEDULE                  | AGENCY/<br>CONTRACTOR                     | EVALUATION           | TECHNICAL<br>CONTACT             |
|---|------------|-----------|---------------------------|---|----------------------|----------------------------------|
| <b>TRANSPORTATION SERVICES FOR SPECIAL USER GROUPS</b>                          |            |           |                           |   |                      |                                  |
| <b>Coordinated Services for the Elderly and Handicapped</b>                     |            |           |                           |   |                      |                                  |
| Elderly and Handicapped Social Service Coordination                             | CA-06-0134 | \$160,000 | March 1980-<br>March 1981 | City of San Diego,<br>Calif.              | N/A                  | Larry A. Bruno<br>(202) 426-4984 |
| Rhode Island Coordination Planning Project                                      | RI-06-0012 | \$70,000  | Oct. 1981-<br>April 1981  | Rhode Island DOT                          | N/A                  | Larry A. Bruno<br>(202) 426-4984 |
| <b>User Subsidy Demonstrations</b>  |            |           |                           |   |                      |                                  |
| Private-Public Sector Integration   | CA-06-0170 | \$175,000 | May 1982-<br>May 1984     | City of San Diego,<br>Calif.              | Crain and Associates | Larry A. Bruno<br>(202) 426-4984 |
| <b>Other Activities</b>   |            |           |                           |   |                      |                                  |
| Local Government Options in Providing Transportation for the Disabled           | DC-06-0393 | \$300,000 | Aug. 1982-<br>Aug. 1983   | International City Management Association | N/A                  | Patricia Cass<br>(202) 426-4984  |
| Technical Assistance to State and Local Areas                                   | IT-06-0274 | \$300,000 | June 1981-<br>June 1982   | Harold Russell Associates, Inc.           | N/A                  | Patricia Cass<br>(202) 426-4984  |
| Study of Costs and Ridership of Transportation Services for Handicapped Persons | VA-06-0076 | \$100,000 | Aug. 1980-<br>Aug. 1981   | Chase, Rosen and Wallace Inc.             | N/A                  | Patricia Cass<br>(202) 426-9484  |
| Use of Volunteers in Providing Transportation for the Handicapped               | DC-06-0417 | \$80,000  | Oct. 1982-<br>April 1983  | Del Green Associates                      | N/A                  | Patricia Cass<br>(202) 426-4984  |
| Ride to Work for the Handicapped  | NY-06-0096 | \$30,000  | April 1983-<br>Aug. 1983  | Vera Institute                            | N/A                  | Patricia Cass<br>(202) 426-4984  |

## Service and Methods

| PROJECT TITLE   | NUMBER                   | FUNDING   | SCHEDULE                  | AGENCY/<br>CONTRACTOR  | EVALUATION                             | TECHNICAL<br>CONTACT                       |
|---|--------------------------|-----------|---------------------------|--|--|--|
| <b>TRANSPORTATION SERVICES FOR SPECIAL USER GROUPS (CONT.)</b>            |                          |           |                           |  |  |  |
| <b>Other Activities (Cont.)</b>   |                          |           |                           |  |  |  |
| Inner City Mobility   | CT-06-0010               | \$360,000 | Sept. 1980-<br>Sept. 1984 | GBTD   | TSC;<br>COMSIS Corp.                   | Mary Martha<br>Churchman<br>(202) 426-4984 |
| <b>FARE AND PRICING POLICIES</b>  |                          |           |                           |  |  |  |
| <b>Promotional Fare Incentive Strategies</b>                              |                          |           |                           |  |  |  |
| CBD Off-Peak Fare-<br>Free Transit  | NY-06-0064               | \$407,380 | June 1978-<br>June 1982   | Capital District<br>Transportation<br>Authority,<br>Albany, N.Y. | TSC; Cambridge<br>Systematics,<br>Inc. | Roger Tate<br>(202) 426-4984               |
| Fare and Service<br>Improvement<br>Demonstration                          | TN-06-0006-1             | \$450,000 | Nov. 1978-<br>June 1982   | City of<br>Knoxville,<br>Tenn.                                   | TSC;<br>Multisystems,<br>Inc.          | Roger Tate<br>(202) 426-4984               |
| Promotional Pricing<br>Research Assistance                                | PA-06-0056               | \$85,000  | March 1980-<br>March 1983 | Pennsylvania<br>State University                                 | N/A                                    | Roger Tate<br>(202) 426-4984               |
| Price Incentives<br>Through Merchant/<br>Transit Operator<br>Coordination | WA-06-0018<br>WA-52-0001 | \$550,976 | April 1980-<br>Nov. 1983  | TSC; City of<br>Spokane, Wash.                                   | TSC;<br>SYSTAN, Inc.                   | Roger Tate<br>(202) 426-4984               |
| <b>Transit Fare Payment (TFP) Options</b>                                 |                          |           |                           |  |  |  |
| Transit Fare Prepay-<br>ment Through<br>Employers                         | CA-06-0102               | \$470,997 | June 1977-<br>Oct. 1982   | Sacramento<br>(Calif.) Regional<br>Transit                       | TSC;<br>SYSTAN, Inc.                   | Stewart N. McKeown<br>(202) 426-4984       |
| Transit Fare Prepay-<br>ment Through<br>Employers                         | CA-06-0162-2             | \$326,697 | Oct. 1980-<br>Sept. 1982  | City of<br>Sacramento,<br>Calif.                                 | N/A                                    | Stewart N. McKeown<br>(202) 426-4984       |
| Technical Support<br>Services   | VA-06-0072               | \$146,569 | Jan. 1980-<br>Jan. 1983   | SG Associates  | N/A                                    | Roger Tate<br>(202) 426-4984               |
| Student Transit<br>Fare Prepayment  | AZ-06-0009               | \$183,680 | Aug. 1979-<br>May 1982    | City of Tucson,<br>Ariz.   | TSC;<br>SYSTAN, Inc.                   | Stewart N. McKeown<br>(202) 426-4984       |
| Variable Work Hour/<br>Employee Pass<br>Program                           | MN-06-0013               | \$254,559 | March 1980-<br>July 1982  | Duluth (Minn.)<br>Transit Authority                              | TSC; Charles<br>River Associates       | Stewart N. McKeown<br>(202) 426-4984       |



## Service and Methods

| PROJECT TITLE   | NUMBER       | FUNDING   | SCHEDULE                 | AGENCY/<br>CONTRACTOR                  | EVALUATION                             | TECHNICAL<br>CONTACT                          |
|---|--------------|-----------|--------------------------|--|--|---|
| <b>FARE AND PRICING POLICIES (CONT.)</b>  |              |           |                          |  |  |   |
| <b>Transit Fare Prepayment (TFP) Options (Cont.)</b>  |              |           |                          |  |  |   |
| Integrated Fare Design  | CA-06-0137   | \$50,000  | Sept. 1979-<br>Jan. 1982 | MTC, Berkeley,<br>Calif.               | TSC; Charles<br>River Associates       | Roger Tate<br>(202) 426-4984                  |
| Integrated Fare Evaluation  | GA-06-0012   | \$126,000 | Aug. 1979-<br>April 1981 | MARTA                                  | TSC; Charles<br>River Associates       | Roger Tate<br>(202) 426-4984                  |
| Brokerage Demonstration: Pricing  | CT-06-0008   | \$501,002 | Oct. 1979-<br>June 1984  | GBTD                                   | TSC; COMSIS<br>Corp.                   | Roger Tate<br>(202) 426-4984                  |
| Promotional Fare Incentives for Increasing Ridership and Promoting Private Sector Involvement | PA-06-0055   | \$235,671 | Jan. 1980-<br>Jan. 1983  | COLTS,<br>Scranton, Pa.                | TSC; Crain<br>and Associates           | Roger Tate<br>(202) 426-4984                  |
| TFP Pricing Methodology   | OH-06-0036   | \$133,448 | Nov. 1981-<br>Nov. 1983  | Queen City Metro,<br>Cincinnati, Ohio  | TSC                                    | Stewart N. McKeown<br>(202) 426-4984          |
| Transit Fare Prepayment   | MD-06-0031-1 | \$100,000 | Sept. 1980-<br>Feb. 1982 | Ecosometrics,<br>Inc.                  | N/A                                    | Stewart N. McKeown<br>(202) 426-4984          |
| <b>Fare and Service Management Strategies</b>   |              |           |                          |  |  |   |
| Price and Service Improvement Demonstration   | WA-06-0010   | \$900,000 | June 1978-<br>June 1982  | City of<br>Vancouver, Wash.            | TSC; SYSTAN,<br>Inc.                   | Roger Tate<br>(202) 426-4984                  |
| Fare and Service Improvement Demonstration  | TN-06-0006   | \$450,000 | Nov. 1978-<br>June 1982  | City of<br>Knoxville, Tenn.            | TSC;<br>Multisystems,<br>Inc.          | Roger Tate<br>(202) 426-4984                  |
| Technical Support Services  | PA-06-0054   | \$105,255 | Jan. 1980-<br>Jan. 1983  | Booz, Allen and<br>Hamilton, Inc.      | N/A                                    | Roger Tate<br>(202) 426-4984                  |
| Brokerage Demonstration: Pricing  | CT-06-0008   | \$501,002 | Oct. 1979-<br>June 1984  | GBTD                                   | TSC; COMSIS<br>Corp.                   | Mary Martha<br>Churchman<br>(202) 426-4984    |
| Transit Resource Productivity Demonstration   | NE-06-0003   | \$358,115 | Sept. 1978-<br>Jan. 1982 | Metro Area<br>Transit,<br>Omaha, Nebr. | TSC;<br>Cambridge<br>Systematics, Inc. | Roger Tate<br>(202) 426-4984                  |
| Transit Resource Productivity Demonstration   | OH-06-0027   | \$752,000 | Oct. 1978-<br>May 1985   | Central Ohio<br>Transit Authority      | TSC; COMSIS                            | Stewart N. McKeown<br>Corp.<br>(202) 426-4984 |

## Service and Methods

| PROJECT TITLE   | NUMBER     | FUNDING     | SCHEDULE                  | AGENCY/<br>CONTRACTOR                    | EVALUATION        | TECHNICAL<br>CONTACT                 |
|---|------------|-------------|---------------------------|--|-------------------|--------------------------------------|
| <b>FARE AND PRICING POLICIES (CONT.)</b>                  |            |             |                           |  |                   |                                      |
| <b>Fare and Service Management Strategies (Cont.)</b>     |            |             |                           |  |                   |                                      |
| Fare and Service Demonstration Design and Resource Center | MD-06-0093 | \$399,978   | Sept. 1982-<br>Sept. 1985 | Ecosometrics, Inc.                       | N/A               | Stewart N. McKeown<br>(202) 426-4984 |
| National Study of Peak/Off-Peak Fare Programs             | CA-06-0182 | \$69,936    | Aug. 1982-<br>Aug. 1983   | University of California at Berkeley     | N/A               | Stewart N. McKeown<br>(202) 426-4984 |
| Microcomputer Application for Transit Pricing Policies    | VA-06-0102 | \$355,000   | March 1982-<br>March 1983 | Technology Research and Evaluation Corp. | N/A               | Stewart N. McKeown<br>(202) 426-4984 |
| Rationalizing Service and Fare Policies                   | NJ-06-0017 | \$84,771    | Sept. 1982-<br>Dec. 1983  | Rutgers University                       | N/A               | Stewart N. McKeown<br>(202) 426-4984 |
| Determining Alternate Transit Fare Policies               | IL-06-0054 | \$59,999    | Sept. 1982-<br>Oct. 1983  | Northwestern University (Ill.)           | N/A               | Stewart N. McKeown<br>(202) 426-4984 |
| <b>Fare Collection Techniques</b>                         |            |             |                           |  |                   |                                      |
| Automated Billing and Self-Service Fare Collection        | CA-06-0157 | \$466,059   | Sept. 1981-<br>July 1983  | Santa Cruz County, Calif.                | N/A               | Stewart N. McKeown<br>(202) 426-4984 |
| Price and Service Improvement Demonstration               | WA-06-0010 | \$900,000   | June 1978-<br>June 1982   | City of Vancouver, Wash.                 | TSC; SYSTAN, Inc. | Roger Tate<br>(202) 426-4984         |
| Self-Service Fare Collection                              | OR-06-0008 | \$1,218,350 | Sept. 1981-<br>March 1983 | City of Portland, Oreg.                  | N/A               | Stewart N. McKeown<br>(202) 426-4984 |
| Evaluation of Self-Service Fare Collection Implementation | CA-06-0158 | \$100,000   | July 1981-<br>July 1982   | City of San Diego, Calif.                | N/A               | Stewart N. McKeown<br>(202) 426-4984 |
| Self-Service/Automatic Fare Billing Demonstration Design  | VA-06-0099 | \$801,893   | Sept. 1978-<br>March 1983 | MITRE Corp.                              | N/A               | Stewart N. McKeown<br>(202) 426-4984 |
| Automated Transit Fare Billing System                     | MA-06-0147 | \$416,557   | Sept. 1982-<br>Sept. 1984 | Merrimack Valley (Mass.) RTA             | N/A               | Stewart N. McKeown<br>(202) 426-4984 |

## Service and Methods

| PROJECT TITLE   | NUMBER     | FUNDING   | SCHEDULE              | AGENCY/<br>CONTRACTOR               | EVALUATION                    | TECHNICAL<br>CONTACT                 |
|---|------------|-----------|-----------------------|-------------------------------------|-------------------------------|--------------------------------------|
| <b>FARE AND PRICING POLICIES (CONT.)</b>                                |            |           |                       |                                     |                               |                                      |
| <b>Auto Management Techniques</b>                                       |            |           |                       |                                     |                               |                                      |
| Parking Management and Employee Incentive Program                       | CA-06-0140 | \$520,689 | Feb. 1980-Aug. 1981   | City of Los Angeles, Calif.         | Crain and Associates          | Stewart N. McKeown<br>(202) 426-4984 |
| Employee Transportation Program Design                                  | CA-06-0139 | \$9,800   | Feb. 1980-Jan. 1981   | Wallen and Associates               | N/A                           | Stewart N. McKeown<br>(202) 426-4984 |
| Technical Support Services  | IT-06-0233 | \$382,856 | Jan. 1980-Jan. 1983   | Urban Institute                     | N/A                           | Roger Tate<br>(202) 426-4984         |
| Parking Pricing Demonstration   | WI-06-0006 | \$821,221 | Oct. 1978-June 1981   | City of Madison, Wis.               | TSC; Charles River Associates | Stewart N. McKeown<br>(202) 426-4984 |
| Permit Parking and Transit Improvement Program                          | CA-06-0129 | \$420,599 | July 1979-Oct. 1982   | Santa Cruz County, Calif.           | TSC; Crain and Associates     | Stewart N. McKeown<br>(202) 426-4984 |
| Permit Parking and Transit Improvement Program                          | CA-06-0126 | \$299,950 | April 1979-Oct. 1982  | City of Hermosa Beach, Calif.       | TSC; SYSTAN, Inc.             | Stewart N. McKeown<br>(202) 426-4984 |
| Road Pricing Feasibility Study  | HI-06-0004 | \$117,200 | Oct. 1979-Nov. 1981   | Hawaii DOT                          | N/A                           | Stewart N. McKeown<br>(202) 426-4984 |
| <b>Private Sector Involvement</b>                                       |            |           |                       |                                     |                               |                                      |
| Public/Private Transportation Management                                | CT-06-0014 | \$222,000 | Oct. 1982-Oct. 1984   | Greater Hartford Ridesharing Agency |                               | Stewart N. McKeown<br>(202) 426-4984 |
| Private/Public Transportation Management Initiative for Downtown Denver | CO-06-0013 | \$300,000 | Sept. 1982-Sept. 1984 | Denver Civic Ventures               |                               | Stewart N. McKeown<br>(202) 426-4984 |
| Eugene, Oregon Parking  | OR-06-0010 | \$293,260 | May 1983-June 1985    | City of Eugene, Ore.                |                               | Roger Tate<br>(202) 426-4984         |



## Service and Methods

| PROJECT TITLE   | NUMBER     | FUNDING     | SCHEDULE                  | AGENCY/<br>CONTRACTOR                               | EVALUATION                       | TECHNICAL<br>CONTACT             |
|---|------------|-------------|---------------------------|---|----------------------------------|----------------------------------|
| <b>MARKETING TECHNIQUES</b>   |            |             |                           |   |                                  |                                  |
| Transit Marketing Project   | IT-06-0238 | \$225,000   | Sept. 1980-<br>Jan. 1984  | Expand Associates                                   | N/A                              | Roger Tate<br>(202) 426-4984     |
| Transit Marketing Program for Birmingham, Alabama                   | AL-06-0008 | \$150,000   | Aug. 1982-<br>Jan. 1984   | Birmingham-Jefferson County Transit Authority       | N/A                              | Roger Tate<br>(202) 426-4984     |
| Demonstration Project for Arkadelphia, Malvern and Benton, Arkansas | AR-06-0002 | \$150,000   | Aug. 1982-<br>Jan. 1984   | Arkansas Highway and Transportation Dept.           | N/A                              | Roger Tate<br>(202) 426-4984     |
| Transit Management  | OH-06-0038 | \$163,500   | Jan. 1983-<br>June 1983   | Western Reserve Transit Authority, Youngstown, Ohio | N/A                              | Roger Tate<br>(202) 426-4984     |
| Transit Awareness   | IL-06-0050 | \$135,000   | Dec. 1982-<br>Oct. 1983   | Dellingham Associates, Inc.                         | N/A                              | Roger Tate<br>(202) 426-4984     |
| <b>CONVENTIONAL TRANSIT SERVICE INNOVATIONS</b>                     |            |             |                           |   |                                  |                                  |
| <b>Auto Restricted Zones</b>  |            |             |                           |   |                                  |                                  |
| Memphis Auto Restricted Zone  | TN-06-0008 | \$1,025,000 | Sept. 1978-<br>Sept. 1983 | City of Memphis, Tenn.                              | TSC; Charles River Associates    | Joseph Goodman<br>(202) 426-4984 |
| Providence Auto Restricted Zone                                     | RI-06-0010 | \$960,000   | June 1981-<br>June 1984   | City of Providence, RI                              | TSC; Charles River Associates    | Joseph Goodman<br>(202) 426-4984 |
| Impact of UMTA's Auto Restricted Zone Program                       | PA-06-0073 | \$85,000    | Sept. 1982-<br>Aug. 1983  | Pennsylvania State University                       | N/A                              | Joseph Goodman<br>(202) 426-4984 |
| <b>Priority Treatments for High-Occupancy Vehicles</b>              |            |             |                           |   |                                  |                                  |
| Corridor Improvements in Houston, Texas                             | TX-06-0018 | \$1,051,760 | June 1975-<br>July 1983   | City of Houston, Texas                              | TSC; Cambridge Systematics, Inc. | Joseph Goodman<br>(202) 426-4984 |

## Service and Methods

| PROJECT TITLE  | NUMBER     | FUNDING     | SCHEDULE                  | AGENCY/<br>CONTRACTOR                                     | EVALUATION                                 | TECHNICAL<br>CONTACT             |
|--|------------|-------------|---------------------------|---|--|----------------------------------|
| <b>CONVENTIONAL TRANSIT SERVICE INNOVATIONS (CONT.)</b>            |            |             |                           |   |  |                                  |
| <b>Priority Treatments for High-Occupancy Vehicles (Cont.)</b>     |            |             |                           |   |  |                                  |
| St. Louis<br>CBD Transit<br>Priority Project                       | MO-06-0010 | \$374,000   | Sept. 1979-<br>Oct. 1983  | Bi-State<br>Development<br>Agency, Mo.                    | TSC  | Roger Tate<br>(202) 426-4984     |
| Philadelphia<br>Signal Preemption                                  | PA-06-0053 | \$1,028,080 | Sept. 1979-<br>July 1984  | SEPTA   | TSC;<br>Multisystems,<br>Inc.              | Joseph Goodman<br>(202) 426-4984 |
| I-66 Evaluation  | DC-06-0402 | \$50,000    | May 1982-<br>Oct. 1984    | Washington<br>Metropolitan Area<br>Council of Governments | TSC  | Joseph Goodman<br>(202) 426-4984 |
| <b>General Transit Improvements</b>                                |            |             |                           |   |  |                                  |
| Coordination of<br>School and Public<br>Transportation<br>Services | CA-06-0180 | \$151,650   | Sept. 1982-<br>Aug. 1984  | South Lake Tahoe,<br>Calif.                               | TSC  | Joseph Goodman<br>(202) 426-4984 |
| Commuter Express Bus<br>and Vanpool Services                       | FL-06-0036 | \$500,000   | Sept. 1982-<br>March 1985 | Brevard Transporta<br>tion Authority, Fla.                | TSC  | Joseph Goodman<br>(202) 426-4984 |
| Intercity Bus<br>Demonstration                                     | FL-06-0034 | \$220,000   | Sept. 1982-<br>Aug. 1984  | Florida DOT   | TSC  | Joseph Goodman<br>(202) 426-4984 |
| Reliability and<br>Productivity<br>Improvements                    | CA-06-0171 | \$332,500   | Jan. 1982-<br>Jan. 1985   | SCRTD   | TSC; Multi-<br>systems, Inc.               | Joseph Goodman<br>(202) 426-4984 |
| <b>Transit Reliability</b>   |            |             |                           |   |  |                                  |
| Minneapolis<br>Transit Reliability                                 | MN-06-0011 | \$239,630   | Sept. 1979-<br>July 1982  | Metropolitan<br>Transit<br>Commission, Minn.              | TSC;<br>Multisystems,<br>Inc.              | Joseph Goodman<br>(202) 426-4984 |
| Empirical Methods for<br>Bus Reliability                           | NY-06-0097 | \$58,768    | Sept. 1982-<br>Aug. 1983  | Rensselaer<br>Polytechnic<br>Institute                    | N/A  | Joseph Goodman<br>(202) 426-4984 |
| Inner City<br>Transit<br>Improvement                               | VA-06-0079 | \$591,536   | Nov. 1980-<br>Nov. 1981   | Penntan,<br>Hampton, VA                                   | TSC;<br>Peat, Marwick,<br>Mitchell and Co. | Joseph Goodman<br>(202) 426-4984 |

## Service and Methods

| PROJECT TITLE   | NUMBER     | FUNDING     | SCHEDULE                  | AGENCY/<br>CONTRACTOR                                      | EVALUATION                    | TECHNICAL<br>CONTACT                    |
|---|------------|-------------|---------------------------|--|-------------------------------|---|
| <b>CONVENTIONAL TRANSIT SERVICE INNOVATIONS (CONT.)</b>   |            |             |                           |  |                               |   |
| <b>Transit Information</b>                                |            |             |                           |  |                               |   |
| Computerized Rider Information System                     | PA-06-0058 | \$1,230,024 | Oct. 1980-<br>Sept. 1983  | Erie (Pa.) MTA   | TSC; Charles River Associates | Larry A. Bruno<br>(202) 426-4984        |
| Computerized Rider Information System                     | PA-06-0066 | \$627,000   | Sept. 1981-<br>Sept. 1984 | PAT  | TSC; Crain and Associates     | Larry A. Bruno<br>(202) 426-4984        |
| Computerized Rider Information System                     | NY-06-0092 | \$576,000   | Sept. 1982-<br>Sept. 1983 | Capital District Transit Authority,<br>Albany, N.Y.        | TSC                           | Larry A. Bruno<br>(202) 426-4984        |
| Feasibility Study<br>Computerized Information System      | CA-06-0184 | \$119,000   | Sept. 1982-<br>Oct. 1983  | City of San Rafael,<br>Calif.                              | N/A                           | Larry A. Bruno<br>(202) 426-4984        |
| Assessment of ATIS Impacts at WMATA and SCRTD             | MA-06-0126 | \$165,000   | April 1980-<br>Dec. 1983  | TSC; Wilson-Hill Associates, Inc.                          | N/A                           | John Durham<br>(202) 426-4984           |
| <b>PARATRANSIT SERVICES</b>                               |            |             |                           |  |                               |   |
| <b>Integration of Paratransit and Fixed Route Systems</b> |            |             |                           |  |                               |   |
| Orange County Computerized Demand-Responsive Transit      | CA-06-0097 | \$2,833,431 | May 1978-<br>June 1983    | Orange County (Calif.) Transit District                    | TSC; Crain and Associates     | Paul Fish<br>(202) 426-4984             |
| San Diego Taxi Feeder                                     | CA-06-0165 | \$360,000   | Oct. 1981-<br>March 1984  | San Diego (Calif.) Transit Authority                       | TSC                           | Larry A. Bruno<br>(202) 426-4984        |
| Memphis Taxi Feeder                                       | TN-06-0013 | \$640,000   | Sept. 1982-<br>April 1984 | Memphis Area Transit Authority                             | TSC                           | Larry A. Bruno<br>(202) 426-4984        |
| Dade County Integrated Transit                            | FL-06-0023 | \$700,000   | Sept. 1981-<br>Sept. 1984 | Dade County (Fla.) Office of Transportation Administration | TSC; Charles River Associates | Paul Fish<br>(202) 426-4984             |
| Low Density Design Study                                  | PA-06-0074 | \$60,000    | Oct. 1982-<br>June 1983   | PAT  | N/A                           | Mary Martha Churchman<br>(202) 426-4984 |



## Service and Methods

| PROJECT TITLE  | NUMBER     | FUNDING     | SCHEDULE                 | AGENCY/<br>CONTRACTOR  | EVALUATION                                    | TECHNICAL<br>CONTACT                       |
|--|------------|-------------|--------------------------|--|---|--|
| <b>PARATRANSIT SERVICES (CONT.)</b>                  |            |             |                          |  |   |  |
| <b>Transportation Brokerage</b>                      |            |             |                          |  |   |  |
| St. Louis Brokerage                                  | MO-06-0012 | \$140,000   | Aug. 1981-<br>Jan. 1983  | City of St. Louis,<br>Mo.                                    | N/A   | Mary Martha<br>Churchman<br>(202) 426-4984 |
| RTA Paratransit<br>Brokerage                         | IL-06-0038 | \$550,188   | March 1978-<br>Feb. 1983 | Chicago (Ill.) RTA   | TSC; DeLeuw<br>Cather and Co.                 | Mary Martha<br>Churchman<br>(202) 426-4984 |
| Pittsburgh Paratransit<br>Brokerage<br>Demonstration | PA-06-0042 | \$2,090,000 | July 1978-<br>April 1982 | PAT  | Charles River<br>Associates                   | James Bautz<br>(202) 426-4984              |
| Brokerage<br>Demonstration                           | CT-06-0008 | \$999,205   | Aug. 1978-<br>March 1983 | GBTD   | TSC; COMSIS                                   | Mary Martha<br>Churchman<br>(202) 426-4984 |
| Easy-Ride Transporta-<br>tion Brokerage              | VA-06-0050 | \$570,000   | Sept. 1978-<br>June 1982 | Peninsula<br>Transportation<br>District Com-<br>mission, Va. | TSC; Peat,<br>Marwick,<br>Mitchell<br>and Co. | Paul Fish<br>(202) 426-4984                |
| Audiovisual<br>Brokerage<br>Presentations            | TN-06-0012 | \$24,935    | Sept. 1981-<br>Jan. 1984 | University of<br>Tennessee                                   | N/A   | Mary Martha<br>Churchman<br>(202) 426-4984 |
| <b>Checkpoint Demand-Responsive Services</b>         |            |             |                          |  |   |  |
| Checkpoint Dial-<br>A-Ride Demonstration             | AZ-06-0013 | \$85,000    | Jan. 1981-<br>June 1982  | City of<br>Glendale, Calif.                                  | To Be<br>Determined                           | Larry A. Bruno<br>(202) 426-4984           |
| Checkpoint Dial-<br>A-Ride Demonstration             | MN-06-0015 | \$95,000    | Aug. 1981-<br>Feb. 1983  | Metropolitan<br>Council of Twin<br>Cities, Minn.             | To Be<br>Determined                           | Larry A. Bruno<br>(202) 426-4984           |
| <b>Other Paratransit Innovations</b>                 |            |             |                          |  |   |  |
| Shared Vehicle<br>Demonstration Design               | CA-06-0166 | \$54,000    | Oct. 1981-<br>Sept. 1982 | California<br>DOT  | N/A   | Paul Fish<br>(202) 426-4984                |
| Shared Fleet Urban<br>Mobility Study                 | IN-06-0012 | \$95,000    | Dec. 1982-<br>Aug. 1983  | Purdue University<br>Research<br>Foundation                  | N/A   | Mary Martha<br>Churchman<br>(202) 426-4984 |

## Service and Methods

| PROJECT TITLE                                    | NUMBER     | FUNDING   | SCHEDULE                  | AGENCY/<br>CONTRACTOR  | EVALUATION                       | TECHNICAL<br>CONTACT                    |
|--|------------|-----------|---------------------------|--|----------------------------------|---|
| <b>PARATRANSIT SERVICES (CONT.)</b>              |            |           |                           |  |                                  |   |
| <b>Other Paratransit Innovations (Cont.)</b>     |            |           |                           |  |                                  |   |
| Transportation Cooperative                       | MA-06-0148 | \$40,000  | Sept. 1982-<br>Oct. 1983  | Transporting the Handicapped and Elderly in Massachusetts (THEM) | TSC; Cambridge Systematics, Inc. | Lary A. Bruno<br>(202) 426-4984         |
| Neighborhood Volunteer Vans                      | AL-06-0007 | \$60,000  | Sept. 1982-<br>Sept. 1983 | City of Huntsville, Ala.   | TSC; COMSIS                      | Paul Fish<br>(202) 426-4984             |
| Ride Sharing Back-Up System                      | CA-06-0163 | \$100,000 | Oct. 1981-<br>Sept. 1983  | Golden Gate Bridge, Highway, and Transportation District, Calif. | Crain and Associates             | Paul Fish<br>(202) 426-4984             |
| Local Technical Assistance                       | CA-06-0184 | \$275,000 | Aug. 1982-<br>Aug. 1984   | Los Angeles County Transportation Commission                     | TSC; Charles River Associates    | Larry A. Bruno<br>(202) 426-4984        |
| San Diego Taxi Regulation Study                  | CA-06-0127 | \$90,564  | July 1979-<br>July 1981   | City of San Diego, Calif.  | DeLeuw Cather and Company        | Larry A. Bruno<br>(202) 426-4984        |
| Seattle Regulatory Evaluation                    | WA-06-0019 | \$81,000  | Aug. 1980-<br>Aug. 1981   | City of Seattle, Wash.   | DeLeuw Cather and Company        | Larry A. Bruno<br>(202) 426-4984        |
| Integrated Fleet Rural Paratransit Demonstration | MS-06-0004 | \$190,000 | Oct. 1981-<br>Sept. 1982  | Medgar Evers Fund, Inc.  | Crain and Associates             | Roger Tate<br>(202) 426-4984            |
| Shared Ride Taxi                                 | MA-06-0144 | \$90,000  | March 1982-<br>Jan. 1984  | City of Boston Mass.   | TSC; Multisystems, Inc.          | Larry A. Bruno<br>(202) 426-4984        |
| Late Night Taxi                                  | MI-06-0028 | \$78,000  | March 1982-<br>March 1983 | Ann Arbor Transportation Authority                               | TSC; Multisystems, Inc.          | Mary Martha Churchman<br>(202) 426-4984 |

## Service and Methods

| PROJECT TITLE  | NUMBER     | FUNDING   | SCHEDULE                 | AGENCY/<br>CONTRACTOR          | EVALUATION                   | TECHNICAL<br>CONTACT         |
|--|------------|-----------|--------------------------|--------------------------------|------------------------------|------------------------------|
| <b>RURAL TRANSPORTATION</b>  |            |           |                          |                                |                              |                              |
| Rural Transportation Cooperatives  | DC-06-0406 | \$160,000 | May 1982-<br>May 1984    | Rural America, Inc.            | N/A                          | Roger Tate<br>(202) 426-4984 |
| Assessment of Rural Transportation Needs   | AL-06-0010 | \$160,000 | Dec. 1982-<br>Dec. 1983  | City of Tuskegee, Ala.         | N/A                          | Roger Tate<br>(202) 426-4984 |
| Development of a Rural Non-urbanized Data Base for Private Sector Transportation Initiatives—I | MD-06-0093 | \$15,000  | April 1983-<br>Dec. 1983 | Ecosometrics, Inc.             | N/A                          | Roger Tate<br>(202) 426-4984 |
| Integrated Paratransit Coordination  | MS-06-0004 | \$440,200 | Nov. 1982-<br>Dec. 1985  | Medgar Evers Fund, Inc.        | TSC;<br>Crain and Associates | Roger Tate<br>(202) 426-4984 |
| Assessment of Cooperative Rural Passenger Transportation                                       | DC-06-0392 | \$98,000  | Jan. 1983-<br>Oct. 1983  | U.S. Department of Agriculture | N/A                          | Roger Tate<br>(202) 426-4984 |

## Bibliography

A list of recent reports follows. Please consult previous editions of this Directory for earlier reports. If available, a document number assigned by the National Technical Information Service (NTIS) is listed.

Reports which have not been assigned an NTIS number may not have been published in sufficient quantity for general distribution. Single copies and other information may be available from the issuing agency or organization.

Additional reports relating to the research described in this chapter may become available in the near future. For the

most recent information or suggestions for additional reference materials regarding specific projects, call or write to the person listed as the technical contact in the Project Summary Table.

### TRANSPORTATION SERVICES FOR SPECIAL USER GROUPS

**Mercer County (NJ)  
Coordination/Consolidation  
Demonstration Project, Final Report**  
Proj. NJ-06-0008  
Daniel Fleishman  
March 1982, PB 82-237645

**A Handbook Describing Low Cost Concepts and Techniques to Make Public Transportation More Accessible for Visually and Hearing Impaired Persons**  
Proj. DC-06-0349  
Crain Revis Associates  
April 1982, PB 83-125526

**Paratransit, Inc., Special Transportation Service in Sacramento, California**  
Proj. MA-06-0049  
Crain and Associates  
July 1981, UMTA-06-0049-81-0

**The Runaround: User-Side Subsidies for Mass Transportation in Danville, Illinois, Final Report**  
Proj. IL-06-0034



Crain and Associates  
April 1980, PB 81-151-375

**User-Side Subsidies for Shared-Ride Taxis  
In Kinston, North Carolina**

Proj. NC-06-0003  
Charles River Associates  
October 1980, PB 81-209-710

**A Taxi Scrip Program in Seattle,  
Washington, Final Report**

Project. MA-06-0049  
David Koffman  
September 1982, UMTA MA-06-0049-82-2

**The Milwaukee County User-Side Subsidy  
Program: A Case Study, Final Report**

Proj. MA-06-0049  
Mary Lovely  
September 1982, PB 83-144089

**National User-Side Subsidy Inventory,  
Final Report**

Proj. MA-06-0049  
Crain and Associates, Inc.  
May 1982

**Trip: The Transportation Renumeration  
and Incentive Program In West Virginia,  
1974-1979, Final Report**

David A. Curry  
Proj. WV-06-0008  
July 1982, PB 83-144055

**Recreational Transit Service to the  
California Santa Monica Mountains, Final  
Report**

Proj. CA-06-0142  
Peter Webb  
April 1982, PB 82-230483

**Accessible Bus Service in St. Louis,  
Missouri, Final Report**

Proj. MA-06-0049  
Applied Resource Integration, Ltd.  
February 1980, UMTA-MA-06-0049-80-6

**Fixed-Route Accessible Bus Service in  
Connecticut: A Case Study**

Proj. MA-06-0049

Charles River Associates  
July 1981, UMTA-MA-06-0049-81-5

**The Accessible Fixed-Route Bus Service  
Experience**

Proj. MA-06-0049  
Transportation Systems Center  
May 1981, PB 81-238-990

**FARE AND PRICING POLICIES**

**Albany CBD Fare-Free Demonstration:  
Final Report**

Proj. NY-06-0064  
Cambridge Systematics, Inc.  
October 1981

**Denver Off-Peak Fare-Free Public Transit  
Experiment: Final Report**

Proj. MA-06-0049  
Transportation Systems Center  
March 1980, PB 298-783

**Findings of Preliminary Analysis of the  
Trenton Off-Peak Fare-Free Transit  
Demonstration: Final Report**

Proj. NY-52-0001  
Transportation Systems Center  
September 1981, PB 298-893

**Demonstration of Transit Fare Prepayment  
Promoted by Employers in Jacksonville,  
Florida: Final Report**

Proj. FL-06-0016  
Transportation Systems Center  
July 1981

**The Costs of Transit Fare Prepayment  
Programs: A Parametric Cost  
Analysis—Executive Summary**

Proj. MD-06-0031  
Ecosometrics, Inc.  
February 1983.

**The Costs of Transit Fare Prepayment  
Programs: A Parametric Cost  
Analysis—Final Report**

Proj. MD-06-0031  
Ecosometrics, Inc.  
February 1983

**The El Segundo Employment Center  
Subscription Bus Service Demonstration:  
Executive Summary—Final Report**

Proj. CA-06-0109  
Systan, Inc.  
July 1982, UMTA-CA-06-0109082-1

**Vancouver, Washington: Price and Service  
Demonstration, Phase I**

Proj. WA-06-0010  
Transportation Systems Center  
June 1981

**Patronage Impacts of Changes in Transit  
Fares and Services**

Proj. MD-06-0031  
Ecosometrics, Inc.  
February 1983

**Self Service Fare Collection: Canadian  
Experience and U.S. Implications**

Proj. VA-06-0049  
Mitre Corporation  
April 1982

**Evaluation of the Washington, D.C.  
Parking Enforcement Program**

Peat, Marwick, Mitchell & Co.  
September 1982, UMTA-MA-06-0049-82-10

**CONVENTIONAL TRANSIT SERVICE  
INNOVATIONS**

**Auto Restricted Zones/Multi-User Vehicle  
System Study**

**Vol. I, Auto Restricted Zones:  
Background and Feasibility**

**Vol. II, Multi-User Vehicle Systems:  
Feasibility Assessment**

**Vol. III, Auto Restricted Zones:  
Plans for Five Cities**

**Vol. IV, Site Selection Methodology**

**Technical Appendix: Boston ARZ Study**

**Technical Appendix: Burlington ARZ Study**

**Technical Appendix: Memphis ARZ Study**

**Technical Appendix: Providence ARZ  
Study**

**Technical Appendix: Tucson ARZ Study**  
Proj. VA-06-0042

Alan M. Voorhees, Inc., Moore-Heder, and  
Cambridge Systematics, Inc.  
PB 286-313 to 321

**Downtown Crossing: Auto Restricted  
Zone in Boston**

Cambridge Systematics, Inc.  
May 1982, UMTA-MA-06-0049-82-3

**Houston North Freeway Contraflow Zone  
Demonstration**

Cambridge Systematics, Inc.  
June 1982, UMTA-MA-06-0049-82-12

**The Coordination of Pupil and Non-Pupil  
Transportation**

Proj. MA-06-0049  
Multisystems, Inc.  
January 1982, UMTA-MA-06-0049-81-13

**Articulated Bus Evaluation**

Proj. MA-06-0049  
Cambridge Systematics, Inc.  
May 1982, UMTA-MA-06-0049-82-1

**Proceedings of the Telephone Transit  
Information Systems Workshop**

Proj. VA-06-0052  
MITRE Corporation  
February 1981

**Automated Transit Information Systems  
(ATIS)**

**Mechanization Concepts for Improved  
Responsiveness**

Proj. DC-06-0295  
National Capital Systems  
April 1981

**Analysis of Results of Transit Telephone  
Information System Survey**

Proj. VA-06-0052  
MITRE Corporation  
October 1980

**Integration of ATIS with Current  
Automated Transit Systems**

Proj. VA-06-0052  
MITRE Corporation  
February 1981

**Computerized Voice Response for an ATIS**

Proj. VA-06-0054  
Input/Output Computer Services  
December 1980

**Technical Study of the Need and  
Feasibility of an Integrated Transit  
Information System for the New York/New  
Jersey Metropolitan Region**

Proj. NY-06-0077  
Port Authority of New York and New Jersey  
October 1981

**Airport ATIS Feasibility Study**

Proj. MA-06-0108  
Transportation Systems Center  
January 1981

**PARATRANSIT SERVICES**

**Evaluation of the Rochester, New York,  
Community Transit Service Demonstration  
Vol. 1, Executive Summary**

Proj. NY-06-0048  
Debra A. Newman and Michael Holoszyk  
October 1980, PB 81-212-433

**The North Eastern Illinois RTA  
Decentralized Paratransit Brokerage  
Program, Final Report**

Proj. IL-06-0038  
William C. Nevel  
September 1982, PB 83-145870

**The Newport News, Virginia, EASYRIDE  
Transportation Brokerage Project, Final  
Report**

Proj. VA-06-0050  
Peat, Marwick, Mitchell & Co.  
September 1982, PB 83-146183

**Evaluation of the EASYRIDE  
Transportation Brokerage Demonstration**

Proj. VA-06-0050  
Peat, Marwick, Mitchell and Co.  
September 1981

**Commuter Connection: Flexible  
Ride-Sharing in Marin County, CA: Final  
Report**

Proj. CA-06-0128  
Edith Dorosin  
December 1981, PB 82-184672

**Golden Gate Vanpool Transportation  
Project Final Report**

Proj. CA-06-0095  
Edith Dorosin  
September 1982, PB 83-145425

**Shared-Ride Taximeters: State-of-the-Art  
and Future Potential**

Proj. MA-06-0049  
Newman, D.A. and Lave, R.E.  
May 1982, PB 82-258708

**Taxi Regulatory Revision in San Diego,  
CA: Final Report**

Proj. MA-06-0049  
Pat Gelb  
(To be published in FY 1983)

**Taxi Regulatory Revision in Seattle,  
Washington: Background and  
Implementation, Interim Report**

Proj. MA-06-0049  
DeLeuw Cather and Co.  
September 1980

**Taxi Regulatory Revision in Seattle, WA:  
Final Report**

Proj. MA-06-0049  
Pat Gelb  
(To be published in FY 1983)

**Taxi Regulatory Revision in Portland,  
Oregon: A Case Study—Final Report**

Proj. MA-06-0049  
Pat Gelb  
September 1982, PB 83-140491

**The Indianapolis Experience with Open  
Entry in the Taxi Industry, Final Report**

Proj. MA-06-0049  
DeLeuw Cather and Co.  
September 1980.

## **RURAL TRANSPORTATION**

### **Rural Transportation Projects on Indian Reservations: A Report on 11 Demonstrations**

Proj. MA-06-0049

Crain and Associates

May 1980, PB 81-111-841

### **Postal Bus Feasibility Study, Final Report**

Proj. MA-06-0049

Multisystems

September 1982, PB 83-144436

### **Service and Methods Demonstration**

#### **Program Reports**

Proj. MA-06-0049

Transportation Systems Center

December 1981, PB 82-190050 and  
82-178633

(Summary Report)



# Planning and Analysis

---

## Trends and Highlights



The work described in this chapter provides essential support for UMTA's planning, operating and capital grant assistance programs. The continuing goal of these efforts is to develop and disseminate analytical techniques for use by federal, state and local agencies in planning, programming, budgeting and implementing improvements in their transportation systems.

A primary product of this program has been the Urban Transportation Planning System (UTPS). UTPS is a coordinated collection of computer software, technical manuals and training materials developed and distributed by UMTA and the Federal Highway Administration (FHWA). UTPS is now used by over 300 planning agencies.

Recent emphasis has been placed on providing transit and paratransit operators with analysis support and on helping them to exploit the rapidly evolving computer technologies, particularly microcomputers. Training courses in microcomputers, transportation planning, and transit operations are used to teach the latest computerized and manual analysis procedures.

A category of projects called Special Planning Studies supplements UMTA's Technical Studies by focusing on local planning issues with national significance, or on procedures with wide application in the transit industry. Areas investigated include service, land use and energy planning, elderly and handicapped accessibility, and Transportation Systems Management Planning (TSM).

# Transportation Planning Analysis Methods

The transportation planning portion of the program has two purposes. The first is to provide technical assistance to federal, state and regional planners, especially in cities where plans for major capital transit investments may involve UMTA capital grants. The second is to develop analytical methods which improve the planning process, and to package those methods in a form which is both understandable to planners and useful in a variety of urban settings and planning studies.

Technical assistance to the planning community, the most important activity in support of transportation planning analysis, varies considerably in content, form and degree of detail. Intensive support is given to regional agencies and transit operators that have applied for major capital grants. Technical documents addressing a variety of planning issues—ranging from guidelines on Environmental Impact Statement (EIS) preparation to course lecture guides on several UTPS programs—are published and distributed. Courses are offered in planning methods and, when the nature of the study warrants such involvement, on-site assistance is offered to state or regional agencies—and, in one instance, at the request of the State Department, to a foreign government.

During FY 82, reviews of EIS's and other planning documents for transit corridor studies in San Jose, Calif., Sacramento, Calif., Chicago, Ill., St. Louis, Mo., and Washington, D.C., were written. This process requires that an analytically skilled reviewer follow the study closely from its inception, making sure that the



***UTPS publishes up-to-date reference and instructional materials relevant to microcomputer applications in the field of transportation.***

planners performing the study use evaluation measures which will help them arrive at sound decisions, based on objective and analytically valid methodologies. Planning reviews are performed in-house by UMTA personnel to avoid possible conflicts of interest involving outside consultants.

In FY 82, a major new effort was initiated to provide timely and effective support to computer users at state and regional planning agencies. Through contracts with COMSIS Corporation and Price, Williams and Associates (PWA), the

UTPS Support Center was established to disseminate expert information about UTPS and other planning topics in both written and verbal form. COMSIS now has a toll-free telephone number at the disposal of agencies with specific questions about program operation or performance. The document distribution center at PWA maintains address lists of planning agencies, transit operators, and consultants, and fills requests for the many manuals, users' guides and planning documents developed by UMTA.

The microcomputer planning support



center at TSC disseminates information about the use of microcomputers in transportation planning. It also serves as a software clearinghouse by distributing public-domain planning software to anyone requesting it. Most of this software has been contributed by planners from around the country who developed the software for their own use. Some of the software distributed was developed by UMTA in response to specific needs not met by commercial or contributed software.

In conjunction with the FHWA, week-long introductory and advanced transportation planning courses are being taught several times a year. The advanced UTPS course mentioned in INNOVATION 81 has evolved into a seminar in which experienced UTPS users are given the opportunity to learn about the latest tools available from UMTA, and to interact with one another in sharing ideas and solutions to UTPS related problems.

A new release of UTPS was submitted to selected UTPS users on a trial basis for testing. These pilot applications resulted in numerous suggestions for minor changes which will be incorporated in the forthcoming full release of UTPS. This release contains software enhancements to facilitate the coding of transportation networks, estimate highway traffic volumes more accurately, compute a wider range of system evaluation measures, and interface with non-UTPS software more easily.

## Transit Operations Analysis Methods

The objective of transit operations support is to provide improved tools,



*UTPS enables regional planners to forecast needs for complex mixes of both highway and transit.*

technical information and training for transit and paratransit operators. Improved tools often involve the use of computer systems to assimilate the vast quantity of information which transit operators must deal with on a daily basis. Automation in the transit industry is advancing at a rapid rate, particularly in the area of microcomputers. Operators need to be kept abreast of the latest software and hardware available to meet their needs.

### Fixed Route Operations

To control rising deficits in fixed-route service, transit managers must have the capability to analyze the causes of changes in revenues and cost. Methods to assess the impact of service changes, work rules, and rates of employment and inflation are needed. In addition, operators require assistance in determining what kind of sampling allows for the most



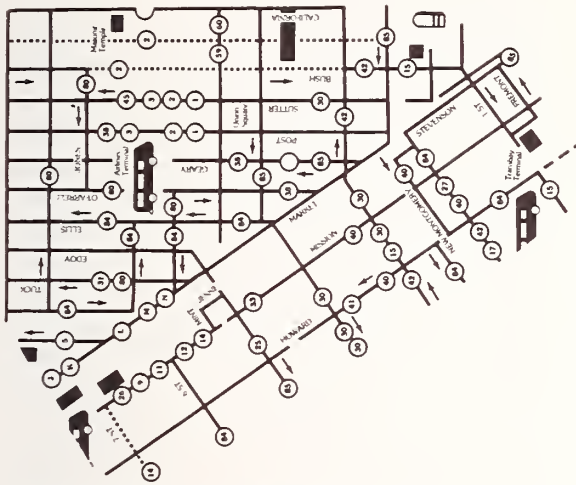

**Networks describe characteristics of roads or transit lines to the computer in the same way a map describes roads to a driver.**

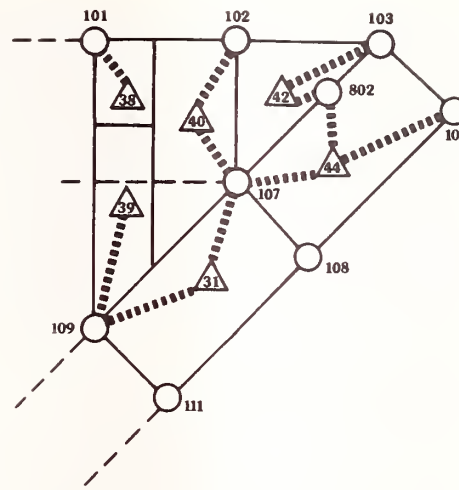

## Paratransit Operations

The demand for paratransit services such as dial-a-ride, shared-ride taxi, car and vanpooling, subscription services and special services for the elderly and handicapped continues to grow throughout the United States. UMTA sponsors research, development and deployment of communications and computer technologies which have the potential for making operational improvements, reducing costs, improving levels of service and management, and coordinating and integrating paratransit with conventional transit.

Computer techniques and software are being developed to provide the needed tools for successful management, operation and planning of flexible paratransit services, and for their coordination with conventional fixed-route, fixed-schedule mass transit systems.

A low-cost ride-sharing computer system was developed to support Knoxville's ride-sharing programs. This microcomputer assists the transportation coordinator by matching transportation services with market demand. Documentation and software are available from the Knoxville Computer Pool of the University of Tennessee.

A relatively large but low-cost computer-assisted routing, scheduling, dispatching and management information system is being developed in Dade County, Fla., and should be available by December 1983. This is a brokerage type of system for coordinating transportation for social service agencies and elderly and handicapped persons. The sources utilize contracted shared-ride taxi as well as vehicles owned by local service agencies. Work is also underway at the Transporta-

cost-effective collection of fixed-route ridership data. Following is a description of some of the activities undertaken in this area during FY 82.

A one day introductory microcomputer course offered through UMTA regional offices covers hardware characteristics, commercial software, and criteria to be considered when selecting a system. The course also includes a discussion of software currently being used by transit agencies, and the demonstration of a scheduling package.

Other activities include the funding of a national microcomputer user group at the Capital District Transportation Authority, the publication of a quarterly newsletter about microcomputer applications, and the establishment of a clearinghouse for the exchange of information and public-domain software.

Microcomputer software is being developed in the areas of financial forecast-

ing, route performance reporting, and scheduling and run cutting. This will be applicable to a wide number of transit agencies, and able to run on numerous different computer systems.

Two documents concerned with microcomputers, "Software and Sourcebook" and "Selected Readings", have been published. The first offers descriptions of transportation software and references, while the second is a series of publications, each presenting information on a particular subject area.

A one week transit operations planning course is offered for professionals new to a transit agency. The course covers operating cost estimation techniques, service design concepts, demand and revenue estimation, and fixed-route service area considerations. Courses in financial forecasting, management auditing, scheduling and advanced microcomputer are planned.

tion Systems Center in the application of low-cost, computer-assisted graphic systems to the solution of dispatching and scheduling problems for the elderly and handicapped. This work is being done in cooperation with Brockton, Mass., which has field tested the system. The completed system should be available by December 1983.

The Paratransit Handbook, which provides a comprehensive review of all aspects of paratransit, is being updated and should be available by December 1983.

## Special Planning Studies

Projects undertaken by the Special Planning Studies Program are determined in large part by major UMTA policy directions and key issues identified in the implementation of UMTA's Technical Studies Grant Program. Each year, a portion of the funds available for technical studies is set aside for use in a variety of special planning studies. These special projects supplement technical studies grants by allowing the study of local issues with national significance, and the development of widely applicable procedures and methods.

In FY 82, a number of special planning studies were initiated to address continuing concern over the increasing cost of providing transit services. This concern indicated the need for improved tools to aid local operators in making short-range planning decisions.

The high cost of energy and the potential for disruption in energy supplies suggest the continued need for studies designed to enable transit operators to plan for improved energy management.

The requirement changes for handicapped accessibility also necessitate improved planning methods for transit management.

Other continuing projects include studies to provide better information on the impact of major transit investments, and studies to assist local areas to address TSM planning needs. Approximately two-thirds of the special study projects were undertaken by local government agencies.

### Rapid Rail Transit Impact Studies

In recent years, UMTA has provided funds for the development of relatively

new rapid rail transit systems. An assessment of how these new systems affect regional development and the institutional environment is useful for future local level and UMTA planning decisions.

The Washington Metropolitan Area Transit Authority (WMATA), Washington, D.C., Impact Study has continued to examine travel behavior, activity and development, and policy interpretation (IT-09-0086, IT-09-0097, DC-09-7001, DC-09-7002, DC-09-7003, DC-09-7005, DC-09-7008). The travel behavior studies include efforts to make short-range forecasts of changes in commuting patterns, and to compare the results with those derived



*Studies to assess the impacts of major transit investments will be used to structure future planning decisions.*



from existing forecast models. Midday travel changes and "induced" travel are also being considered. The activity and development study will monitor changes in such indicators as population and employment, retail sales, property transfers and land value development, and assess the relationship of these changes to the presence of WMATA. Finally, the policy interpretation study will attempt to catalogue the transportation-related goals and expectations of citizens, planners and local officials.

Working papers have recently been prepared in several of these impact assessment areas. The first major product of this effort, an extensive document covering in detail the impact of the initial Red and Blue line segments, was completed in September 1981. A second report, describing trends prior to the advent of Metro, was completed in July 1982.

The Metropolitan Atlanta Rapid Transit Authority (MARTA), Atlanta, Ga., Impact Study (GA-09-0037, GA-09-0038, GA-09-7001, GA-09-7002, GA-09-0057, GA-09-0063) has two components. The main component, a comprehensive assessment of the economic impact of transportation on land use, is being conducted by the Atlanta Regional Commission (ARC). A second study being undertaken by MARTA itself, with funding passed through ARC, is designed to assess the institutional experiences of MARTA in all phases of implementation.

Work has been completed on a detailed study design, broadening its focus to include a wider range of potential transportation impacts. A variety of base data has been collected using the new study design. The collection of data from the time the system began operation in

1979 has been initiated. Initial analysis reports were released in 1981, and in 1982 a key report on work-trip use of the system was completed.

The San Diego area recently completed construction of a new light rail transit system using only local funds. The 16 mile line was opened in July 1981 and extends from downtown San Diego, Calif., to the Mexican border.

In order to evaluate the impact of this system and to assess the impact of systems deployed without federal funds, a project has been initiated by the San

Diego Association of Governments. The project will assess implementation and decision-making processes, line and user characteristics, and impact of the overall transportation system and travel behavior. An initial report on trends prior to the system's implementation was completed in July 1982.

In addition, an informal conference of Impact Study participants was held in late 1981. A report summarizing the proceedings, completed in March 1982, provides a good summary of Impact Studies findings to date (CA-09-7006).



*The economic impacts of San Diego's new light rail system are being studied for the benefit of other cities.*



## **Transportation System Management Planning (TSM)**

TSM is a concept which involves the planning, programming and implementation of low-capital, short-range improvements designed to enhance the efficiency of existing transportation systems.

The TSM special planning studies are designed to assist localities in planning a wide range of TSM strategies. These strategies would increase the efficiency of their transportation systems by 1) identifying institutional arrangements which facilitate effective TSM planning and programming, 2) identifying important factors in the implementation of TSM projects and 3) developing technical tools for use in TSM planning.

It has become increasingly clear that a better understanding is needed of the process by which TSM projects move through planning to implementation. In addition, further information on the impact of previously implemented projects should provide for more effective decisions on the future directions of the TSM Program. Conversely, information on impacts can give local planners a better understanding of what to expect from specific TSM improvement alternatives. A project was therefore undertaken to provide answers in both these areas (NY-09-9001), and a final report for this project was issued in March 1982.

Major institutions such as hospitals, universities and medical centers often generate considerable traffic and require extensive parking and other transportation facilities. When these institutions are located in or near residential areas, these demands are sometimes disruptive to the

neighborhoods. The application of TSM measures, however, could reduce such effects. The San Francisco Institutional TSM Program (CA-09-0070, CA-09-7004) involves the planning and implementation of a set of TSM measures at a number of area hospitals and universities. After completion of planning, each institution designated a transportation coordinator to broker transportation services, including transit, carpooling and vanpooling. Parking management measures were also included in the package. An evaluation of program results was completed in 1982.

As circumstances surrounding the planning, programming and implementation of transportation improvements have changed, it has become increasingly clear that TSM issues must be considered in the long-range as well as in the short-range planning processes. Such long-range planning considerations as funding limitations and energy supply restrictions should also be taken into account. In order to assess this problem in greater detail, a prototype planning study was initiated at the North Central Texas Council of Governments (TX-09-0181). This study will address these issues and attempt to determine a means by which local planning agencies can take account of such constraints in their long-range planning efforts.

Many TSM strategies have significant impacts on local neighborhoods. In addition, a number of strategies are designed to help reduce the neighborhood impact of transportation facilities, services and operation. To assist local jurisdictions in planning such strategies, the District of Columbia DOT is undertaking a prototype study designed to demonstrate how better to address these problems. The study

(DC-09-7006) focuses on ways of insuring adequate and knowledgeable participation in the planning process by neighborhood residents.

An altogether different issue, but still a part of TSM, is strategic planning. The purpose of strategic planning is to identify significant future trends in order to allow an organization to position itself to address the resulting problems and opportunities. WMATA is conducting a prototype study (DC-09-7007) to demonstrate public transit agency application of this concept, which has in the past been confined primarily to private sector corporate planning.

### **Planning Transportation for Elderly and Handicapped People**

Section 16(a) of the Urban Mass Transportation Act declares that it is "...national policy that elderly and handicapped persons have the same right as other persons to utilize mass transportation services, (and) that special efforts shall be made in the planning and design of mass transportation facilities and services so that the availability to elderly and handicapped persons of mass transportation which they can effectively utilize will be assured."

UMTA planning regulations make it clear that addressing this issue is an important aspect of each area's local urban transportation planning process. Thus, local agencies must be able to identify the location and transportation needs of elderly and handicapped persons and to develop services to meet those needs. Former regulations also required local

areas to make fixed-route services accessible to handicapped persons. Although these regulations have been rescinded, many local areas have purchased or are planning to purchase lift-equipped line haul buses. These vehicles may be integrated into local fleets with minimum disruption if certain considerations are taken into account. Guidance on planning methods to accomplish this is being developed for use by local areas.

A number of special studies designed to assist localities in meeting elderly and handicapped planning requirements have been initiated. The specific aims of these studies are to 1) identify cost-effective approaches to data collection, 2) develop procedures for coordinating service, 3) provide information on the effectiveness of various types of services for elderly and handicapped persons and 4) develop methods for planning the phase-in of accessible buses.

A major study in the first area, Data Collection System for Planning Services for Elderly and Handicapped Persons (IT-09-9009), has as its goal the development of practical and effective data collection procedures to facilitate the ongoing planning of special services for elderly and handicapped persons, and in particular wheelchair users and semiambulatory persons. The specific objectives of the study include 1) specifying information requirements for special efforts planning, 2) determining what portion of planning can be satisfied through inexpensive data-gathering methods and self-identification techniques and 3) determining the primary data collection needed for special efforts planning. The data collection system developed by this study was tested by the Montgomery-Greene

County Transportation Planning Program in Ohio (OH-09-7001). The final product of this effort, a manual on an effective and simple data collection method, is being prepared.

A related study addresses the problem of the barrier to coordination of special transportation services presented by inconsistent data and reporting requirements. In this project, a consortium of six states is attempting to develop a simplified, coordinated system of billing and accounting to meet the needs of all federal and state programs which typically support special services. The results of this project (MI-09-7001) could then be

used by coordinated service providers in local areas to insure that all of these needs are met with a minimum of cost and inconvenience.

Another study, Analysis of Existing Elderly and Handicapped Transportation Services (IT-09-9006), attempted to determine what has been accomplished by improved special transportation services, particularly those designed to accommodate wheelchair users and semiambulatory persons. The project approached this problem by conducting 18 case studies of urban areas in which significant improvements have been made. In a report summarizing the findings, ser-



**Reports on special studies in transportation planning are available through UMTA's Technical Assistance Program.**



vice changes are described in detail and an estimate of consequences in terms of cost, street traffic, fares, organizational arrangements, financing, and service levels is made. User group response to implementation is also described.

Another study in this area is related to the evaluation of existing accessible fixed-route services and the development of planning guidelines for new services. This study, Planning for the Phase-In of Accessible Buses (IT-09-9010), is designed to address the fact that for some time after delivery of the initial accessible buses, these vehicles form only a portion of the total fleet in each city. Thus, a primary focus of this project is development of planning methods to assist in the scheduling of accessible vehicles.

This study includes appropriate data collection, marketing, operations coordination, and evaluation recommendations. These recommendations are based, in part, on the experiences of cities that already have accessible, fixed-route service, or are about to institute such service. The final report from this study is now available.

## **Energy Planning Studies**

Recent shifts in federal policy on energy have changed the focus of transportation planning in regard to energy. Petroleum decontrol has several implications for transit, which now has no guaranteed emergency fuel supply or regulated price controls. These factors make it extremely important that transit operators prepare contingency plans for possible energy emergencies. The possibility that energy costs will remain high indicates that trans-

portation decisions must be made to insure maintenance of mobility at minimum cost to system users. Studies in this area are designed to develop planning tools for local application.

The Dallas-Fort Worth, Tex., area prepared an energy contingency plan during 1977. That study indicated the need for further attention to local participation and to the use of school buses and taxis during energy emergencies. Subsequently, in the Dallas-Fort Worth Energy Contingency Planning Prototype Study (TX-09-7001), the North Central Texas Council of Governments investigated the potential role of school buses and taxis. This effort included consideration of legal, institutional and operational aspects of these transportation modes in emergencies. The study also incorporated government energy policy into the process. Local government staff members were enlisted into a network of "energy coordinators" to insure a realistic and effective strategy for energy contingencies. Reports have been prepared describing these efforts.

The role of transit in dealing with energy shortfalls and in inducing conservation of energy is an important one. In order to assist transit operators in responding to these realities, a Prototype Energy Management Planning Study was initiated in Seattle, Wash., (WA-09-0034). This study developed a number of products useful in both contingency and conservation planning. The study updated an existing contingency plan, and in doing so documented the process used. Studies on fuel stockpiling were also conducted. A detailed transit operations energy audit tool was developed and tested. This tool should be useful to other operators wishing to make a comprehensive study of

their system in order to reduce fuel consumption.

A related effort involves preparation of a number of reports on transit fuel procurement issues. These reports (DC-09-9035, DC-09-9044) deal with the general transit fuel situation and the prognosis for the fuel market in emergencies, taking into account both the termination of price controls and allocation rules, and the feasibility of diesel fuel use as a means of mitigating the impact of emergency price increases.

Increasing attention is being paid to energy conservation in the overall urban transportation planning process. As this is a fairly new emphasis for transportation planning, a number of issues have arisen over how this concern can best be integrated into the process. In order to develop additional guidance on this matter, a grant has been made to the New York State DOT (NY-09-8006). Issues addressed include data collection methodology, the role of transit in energy conservation, the sensitivity to energy constraints of work and nonwork travel, the energy impact of TSM actions, and the energy costs involved in implementing various transportation measures and projects. A number of reports covering results in these areas are in preparation. One report, providing detailed manual methods for calculating the energy impacts of various TSM actions, was completed in October 1981.

## **Short-Range Transit Planning**

The emphasis of transit planning has shifted from long-range planning and design of capital-intensive transit system improvements to an emphasis on short-



range, low-cost transit improvements that can effectively increase the efficiency of existing systems. This change in emphasis requires transit operators to make planning decisions in a manner quite different from that of the past. The operator must have a much wider range of accurate and current information to allow continuing evaluation of existing systems.

Projects in this study area are designed to assist in transit planning by providing methods for data collection and analysis, and by developing training material for transit operators and metropolitan planning organization (MPO) personnel on transit planning issues and methods.

The change in focus to short-range planning has increased the importance of transit system surveillance. A significant amount of information is necessary to properly evaluate system performance and identify potential improvements. This information includes patronage data (boarding locations, travel patterns, transfers, etc.), level-of-service indicators (on-time performance, travel speeds, delay points, etc.) and revenue/cost performance.

Unfortunately, existing knowledge regarding such data collection is limited. Little is known about the type, method and frequency of data collection required, or of how transit surveillance should be coordinated with other data collection activities. The Bus System Monitoring System (IT-09-9008) is a study designed to improve and advance transit surveillance techniques and procedures. This study has two objectives: to develop a model monitoring system which will facilitate ongoing evaluation of existing transit services, and to demonstrate the practicality and effectiveness of the model monitoring system

in obtaining current service performance information.

A major interim product of this research effort was a monitoring manual providing a step-by-step procedure for implementing and maintaining the monitoring system. Details for estimating manpower and cost requirements of the system are also included. Efforts to improve and expand the applicability of the system are currently underway.

The proposed system design was tested and validated by the contractor at the Chicago Transit Authority (CTA) and the Regional Transportation Authority

(RTA), Chicago, Ill. The contractor was responsible for the overall design of the system demonstration. Grants (IL-09-7001, IL-09-7002) were made to both transit systems to help defray testing costs.

The bus transit surveillance prototype studies at Boston, Mass. (MA-09-7001), Albany, N.Y. (NY-09-0054), Bridgeport, Conn. (NY-09-0064), and Houston, Tex. (TX-09-0158), have been initiated to provide transit operators with a systematic evaluation method to measure existing service performance, identify new potential areas of transit, and provide insight into the analysis of service alternatives. In



**Chicago and Minneapolis have tested a model bus monitoring system designed to produce better service performance information. This data will help transit managers in efforts to increase overall system efficiency.**

addition, a similar study covering rail transit operations has been initiated in Washington, D.C. (DC-09-0007).

An effective transit planner needs a good working knowledge of all areas of transit operations, including service planning, scheduling, maintenance, finance and facility design. In many cases, new planners do not receive any training in operations and must learn through experience. Coordinated training courses need to be developed to provide new planners with basic knowledge and an understanding of transit operations.

The purpose of the Transit Operations and Planning Course project (IT-09-9011) is to develop a training course which will provide necessary background knowledge and understanding of transit operations for individuals in entry level transit planning positions, and to demonstrate the practicality and effectiveness of the training course method. The work is in two phases. In the first phase, the needs of new transit planners have been determined and a course outlined to meet these needs. A report describing currently available training courses has been prepared. In the second phase, materials for the course were developed. These materials have been tested and validated by the contractor through a trial course.

Estimating costs of proposed service changes is critical to planning improvements of transit services. Unfortunately, state-of-the-art cost estimation techniques are limited. Available methods involve either complex and expensive analyses or simpler, easily applied models that are less expensive but subject to critical theoretical shortcomings which detract from their usefulness.

Thus, the objectives of the Cost Es-

timization Techniques Study (IT-09-9014) are to develop inexpensive, readily applicable cost estimation techniques that are both theoretically sound and accurate in their forecasts, and to demonstrate the effectiveness and practicality of these techniques by on-site testing. The final product of this project will be a report covering the state-of-the-art in cost estimation, the techniques developed by the study, procedures for application of the techniques, and estimated costs involved in use of the proposed methods. A review panel will be formed to assist in the study and to review its products, insuring their usefulness to local transit operators. An interim report describing existing techniques is available.

While knowing the cost of a particular schedule change is important—and the above study will provide further means of assessing these costs—without knowing the impact on system patronage and subsequent revenues, it will not be possible to measure the total impact on system finances. Unfortunately, little is known about the impact of different service variables—e.g., headway, travel time, or socioeconomic factors such as age or income—or about how a transit operator might develop models applicable to a specific system. Because of this, route patronage modeling studies have been initiated by the Greater Cleveland Regional Transit Authority, Cleveland, Ohio (OH-09-7002), the Southern California Rapid Transit District (SCRTD), Los Angeles, Calif. (CA-09-0099), the Tri-County Metropolitan Transportation District of Oregon, Portland, Oreg. (OR-09-7001), and Albuquerque Transit, Albuquerque, N. Mex. (NM-09-7001).

These projects are designed to de-

velop patronage models which can be applied at a route level, and to demonstrate that patronage models can be developed within a local transit operating environment. The report produced as a result of this study should serve as a model by which other local transit operators can develop their own patronage models. It is therefore anticipated that simple, easily applicable methods will be given primary attention. An interim report describing current demand modeling techniques is presently available. Technical assistance for this work is being provided by TSC (MA-09-9009).

A key factor in bus service reliability is maintenance. The ability of a transit operator to maintain vehicles often depends upon the characteristics of the maintenance facility available. Many operators are presently considering rebuilding, replacing or expanding maintenance facilities. However, no comprehensive planning tools are available to insure that operators can plan the best possible facilities. A study on Maintenance Facility Planning (IT-09-9018) has been initiated. This study will assess current thinking on facility planning, and will develop guidelines on a wide range of topics, including siting, site planning and layout, size, operations organization and maintenance planning practices.

Labor accounts for approximately 85 percent of transit costs. In many cases, labor contract provisions governing such factors as spread time maximums and penalties, overtime requirements and straight shift requirements, strongly affect these costs and the ability of transit planners to develop service changes. Transit planners need tools which can help them assess the impact of labor contract provi-



sions on alternative service cost proposals. A project (CA-09-0109) has been initiated to develop such a tool at the SCRTD. A report will be produced describing the methods developed, the results of method application and the implications for service planning of these results. The report is due in 1983.

As transit operating costs continue to rise, it has become increasingly important to insure that transit operator management is as efficient and effective as possible. One way to accomplish this is through the conduct of periodic management assessments. In order to demonstrate the process by which this may be accomplished, a set of three management planning prototype studies has been initiated. These three projects, in Salt Lake City, Utah (UT-09-0015), Kansas City, Mo. (MO-09-0034), and Pittsburgh, Pa. (PA-09-7003), will assess such factors as organizational structure, management information systems, financial procedures and internal planning to determine what improvements are needed. These three reports should serve as useful tools to other operators interested in conducting similar studies.

One of the most important activities conducted by transit operators is scheduling the assignment of vehicles and drivers to routes and runs. While computerized systems are now available to do this (RUCUS), these systems are primarily applicable to larger agencies. Many operators must still perform this function manually. In 1947, the American Transit Association, forerunner of the American Public Transit Association, developed a report on methods for manual scheduling. Though it does not reflect some of the changes undergone in transit since it was

developed, this report is still basically valid and, in order to assist the larger number of operators who still use manual scheduling methods, it has been reprinted.

Most public transit is supported, in part, by public subsidies. In many cases, these subsidies must come from the local jurisdictions served by the operator. In such situations, methods must be developed for subsidy allocation to each jurisdiction involved. This process is often controversial. Local transit planners who must develop and defend alternative arrangements for subsidy allocation are not generally aware of all possible approaches to this problem, or of the advantages and disadvantages of each. A study has therefore been initiated to inventory and evaluate the various methods used (IT-09-9019). The resulting report should prove useful to transit planners faced with this problem.

Transit involves a significant investment in capital assets in order to function effectively. These assets, including vehicles and maintenance facilities, must themselves be maintained and periodically replaced. Recently, the Metropolitan Transportation Commission (MTC) in the San Francisco, Calif., area conducted a study of the facilities and capital stock of the transit operators in the Bay Area. This study pointed out a number of areas in which improved management of capital assets was needed. A grant was made to the MTC (CA-09-7008) to document the study findings and describe in detail the process followed. The resulting report will help operators to evaluate their own efforts in this area.



## Planning and Analysis

| PROJECT TITLE  | NUMBER     | FUNDING   | SCHEDULE                 | AGENCY/<br>CONTRACTOR                            | TECHNICAL<br>CONTACT                  |
|--|------------|-----------|--------------------------|--|---------------------------------------|
| <b>TRANSPORTATION PLANNING ANALYSIS METHODS</b>                        |            |           |                          |  |                                       |
| Transportation<br>Corridor Sketch<br>Planning Model                    | NY-06-0068 | -0-       | Oct. 1978-<br>July 1982  | State University<br>of New York at<br>Buffalo    | Lawrence Quillian<br>(202) 426-9271   |
| Microcomputer TSM<br>Planning Methodology                              | MA-06-0092 | \$34,909  | July 1978-<br>June 1983  | Massachusetts<br>Institute of<br>Technology      | Lawrence Quillian<br>(202) 426-9271   |
| UTPS Maintenance<br>and Enhancement:<br>Highway Network Analysis       | IT-06-0222 | \$425,000 | Nov. 1980-<br>Nov. 1983  | OA0 Corp.  | Edwin I. DeLong<br>(202) 426-9271     |
| UTPS Maintenance and<br>Enhancement: Transit<br>Network Analysis       | IT-06-0223 | \$450,000 | Nov. 1980-<br>Nov. 1983  | Wilson-Hill<br>Associates, Inc.                  | Edwin I. DeLong<br>(202) 426-9271     |
| UTPS Maintenance and<br>Enhancement: Demand<br>and Matrix Manipulation | IT-06-0224 | \$450,000 | Oct. 1980-<br>Oct. 1983  | Automated<br>Sciences Group                      | Edwin I. DeLong<br>(202) 426-9271     |
| UTPS Maintenance and<br>Enhancement: General<br>Purpose Subroutines    | IT-06-0225 | \$150,000 | Nov. 1980-<br>Nov. 1983  | Data Transfor-<br>mation Corp.                   | Edwin I. DeLong<br>(202) 426-9271     |
| UTPS Maintenance and<br>Enhancement: Interactive<br>Graphics           | IT-06-0226 | \$130,000 | Nov. 1981-<br>Nov. 1983  | Systems Architects,<br>Inc.                      | Edwin I. DeLong<br>(202) 426-9271     |
| UTPS Maintenance and<br>Enhancement: Micro-<br>simulation              | IT-06-0227 | \$213,000 | Oct. 1980-<br>Oct. 1983  | Wilson-Hill<br>Associates, Inc.                  | Edwin I. DeLong<br>(202) 426-9271     |
| UTPS User Aids   | DC-06-0240 | -0-       | Sept. 1979-<br>June 1983 | FHWA   | William A. Martin<br>(202) 426-0182   |
| UTPS Technical Support<br>and Dissemination                            | MD-06-0049 | \$250,000 | Multi-year<br>Continuing | Price, Williams<br>and Associates                | Granville E. Paules<br>(202) 426-9271 |
| Interactive GBF/DIME<br>Data Base Management<br>System                 | MN-06-0014 | \$99,500  | June 1980-<br>May 1983   | Metropolitan<br>Council of<br>Twin Cities, Minn. | Granville E. Paules<br>(202) 426-9271 |
| Access to GBF/DIME Files<br>on Microcomputer                           | CA-06-0148 | -0-       | Sept. 1980-<br>Oct. 1983 | Santa Clara<br>County, Calif.                    | Granville E. Paules<br>(202) 426-9271 |
| Traffic Equilibrium<br>Algorithm R&D                                   | CT-06-0011 | \$77,421  | Sept. 1980-<br>Oct. 1983 | Yale University                                  | Anthony Ossi, Jr.<br>(202) 426-9271   |

## Planning and Analysis

| PROJECT TITLE  | NUMBER     | FUNDING   | SCHEDULE                  | AGENCY/<br>CONTRACTOR                           | TECHNICAL<br>CONTACT                  |
|--|------------|-----------|---------------------------|---|---------------------------------------|
| <b>TRANSPORTATION PLANNING ANALYSIS METHODS (CONT.)</b>        |            |           |                           |   |                                       |
| Automated Network Abstraction from GBF/DIME Files              | MD-06-0079 | \$99,500  | Sept. 1980-<br>Oct. 1983  | Baltimore (Md.)<br>Regional Planning<br>Council | Granville E. Paules<br>(202) 426-9271 |
| Traffic Engineering Handbook                                   | MI-06-0027 | \$99,810  | Sept. 1981-<br>March 1983 | University of<br>Michigan                       | Granville E. Paules<br>(202) 426-9271 |
| Technology Transfer of Planning Methods                        | DC-06-0365 | \$100,000 | Jan. 1982-<br>Jan. 1984   | Kendrick and Co.                                | Granville E. Paules<br>(202) 426-9271 |
| Editing and Technical Writing                                  | VA-06-0081 | \$50,000  | Jan. 1982-<br>Jan. 1984   | Marcom<br>Publications                          | Granville E. Paules<br>(202) 426-9271 |
| Support of Census Urban Transportation Planning Package (UTPP) | DC-06-0311 | \$25,000  | Multi-Year<br>Continuing  | FHWA; Bureau of<br>the Census                   | Edwin I. DeLong<br>(202) 426-9271     |
| TSM Case Study   | AZ-06-0015 | \$280,000 | Nov. 1981-<br>Nov. 1983   | Arizona DOT                                     | Granville E. Paules<br>(202) 426-9271 |
| Pilot Testing Of Planning Methods                              | IT-06-0119 | \$350,000 | Jan. 1982-<br>Jan. 1985   | COMSIS Corp.                                    | Anthony Ossi, Jr.<br>(202) 426-9271   |
| Transit Network Design Research                                | PA-06-0068 | \$55,026  | Nov. 1981-<br>Oct. 1983   | University of<br>Pennsylvania                   | Anthony Ossi, Jr.<br>(202) 426-9271   |
| Evaluation of Urban Initiatives                                | TX-06-0028 | \$72,858  | Oct. 1982-<br>Sept. 1983  | Rice Center,<br>Houston, Tex.                   | Paul Verchinski<br>(202) 426-2360     |
| Network Algorithm Research                                     | TX-06-0040 | \$72,524  | Oct. 1982-<br>Oct. 1983   | University of Texas,<br>Austin                  | Anthony Ossi, Jr.<br>(202) 426-9271   |
| Private Investment Case Study for Light Rail Transit Systems   | TX-06-0036 | \$83,180  | Oct. 1982-<br>Oct. 1983   | Rice Center,<br>Houston, Tex.                   | Paul Verchinski<br>(202) 426-2360     |
| National Personnel Transportation Study                        | DC-06-0414 | \$100,000 | Oct. 1982-<br>Oct. 1983   | FHWA: Bureau of<br>Census                       | Edwin I. DeLong<br>(202) 426-9271     |

## Planning and Analysis

| PROJECT TITLE   | NUMBER     | FUNDING              | SCHEDULE                  | AGENCY/<br>CONTRACTOR   | TECHNICAL<br>CONTACT                  |
|---|------------|----------------------|---------------------------|---|---------------------------------------|
| <b>TRANSPORTATION OPERATIONS ANALYSIS METHODS</b>   |            |                      |                           |   |                                       |
| <b>Fixed Route Operation</b>  |            |                      |                           |   |                                       |
| Enhanced Transit<br>Cost and Scheduling<br>Model  | MD-06-0041 | \$99,964             | July 1978-<br>Sept. 1983  | University of<br>Maryland                                     | Thomas J. Hillegass<br>(202) 426-9271 |
| Developmental Support<br>in Transit Operations  | MA-06-0039 | \$223,000<br>(FY 82) | Multi-year<br>Continuing  | TSC   | Granville E. Paules<br>(202) 426-9271 |
| <ul style="list-style-type: none"> <li>• Financial Planning</li> <li>• Maintenance Management</li> <li>• Service Planning</li> <li>• Productivity Initiatives</li> <li>• Microcomputer Technical Support</li> <li>• Network/Operations Research</li> <li>• Paratransit</li> </ul> |            |                      |                           |   |                                       |
| Transit Information System<br>Development   | MD-06-0056 | \$62,677             | Oct. 1979-<br>June 1982   | COMSIS Corp.  | Ron Jensen-Fisher<br>(202) 426-9271   |
| Transit Operations and<br>Financial Planning  | OR-06-0006 | \$51,500             | Oct. 1979-<br>July 1983   | TRIMET  | Ron Jensen-Fisher<br>(202) 426-9271   |
| Transit Operations<br>Planning  | WA-06-0016 | -0-                  | Sept. 1979-<br>Sept. 1982 | Seattle (Wash.)<br>Metro                                      | Ron Jensen-Fisher<br>(202) 426-9271   |
| Computerized Bus<br>Monitoring System   | MA-06-0123 | \$125,000            | Oct. 1982-<br>July 1983   | Multisystems, Inc.  | Brian E. McCollom<br>(202) 426-9271   |
| Microcomputer Transit<br>Operations and Planning<br>Systems   | TX-06-0031 | \$85,000             | Nov. 1981-<br>Oct. 1983   | North Central Texas<br>Council of<br>Governments              | Ron Jensen-Fisher<br>(202) 426-9271   |
| Software Clearing House<br>for Transit Operations   | NY-06-0090 | \$75,000             | Nov. 1981-<br>Oct. 1983   | Capital District<br>Transportation<br>Authority, Albany, N.Y. | Ron Jensen-Fisher<br>(202) 426-9271   |
| Pilot Testing of<br>Microbased Financial<br>Forecasting Tools   | ME-06-0001 | \$26,000             | March 1982-<br>Oct. 1983  | Greater Portland<br>Transit District,<br>Portland, Maine      | Ron Jensen-Fisher<br>(202) 426-9271   |
| Standardization and<br>Documentation of TRANES  | WA-06-0022 | \$149,820            | Aug. 1982-<br>Jan. 1984   | Puget Sound COG,<br>Seattle, Wash.                            | Thomas J. Hillegass<br>(202) 426-9271 |
| Route Data Evaluation<br>Study  | PA-06-0079 | \$100,000            | Oct. 1982-<br>Oct. 1983   | PAT   | Brian McCollom<br>(202) 426-9271      |



## Planning and Analysis

| PROJECT TITLE  | NUMBER     | FUNDING     | SCHEDULE                  | AGENCY/<br>CONTRACTOR                                 | TECHNICAL<br>CONTACT                  |
|--|------------|-------------|---------------------------|---|---------------------------------------|
| <b>TRANSPORTATION OPERATIONS ANALYSIS METHODS</b>                          |            |             |                           |   |                                       |
| <b>Paratransit Operations</b>  |            |             |                           |   |                                       |
| Paratransit Planning Methods   | NH-06-0002 | \$95,435    | Nov. 1981-<br>Oct. 1983   | Dartmouth College                                     | Thomas J. Hillegass<br>(202) 426-9271 |
| Low Cost Ride-Sharing Computer System Support                              | TN-06-0010 | \$61,000    | Oct. 1982-<br>Oct. 1983   | University of Tennessee, Knoxville                    | Edward G. Neigut<br>(202) 426-9271    |
| Operational Software Packages and Support                                  | DC-06-0261 | \$1,177,000 | July 1979-<br>July 1983   | National Bureau of Standards                          | Edward G. Neigut<br>(202) 426-9271    |
| Computer-Assisted Shared-Ride Taxi and Social Services Coordination System | FL-06-0018 | \$900,000   | Oct. 1979-<br>July 1982   | Dade County, Fla.                                     | Edward G. Neigut<br>(202) 426-9271    |
| Computer-Assisted Graphics Research  | MA-06-0054 | \$318,000   | April 1980-<br>Continuing | TSC   | Paul J. Connolly<br>(617) 494-2205    |
| Scheduling Algorithms Research   | MA-06-0071 | \$66,000    | Oct. 1980-<br>Oct. 1983   | Massachusetts Institute of Technology                 | Edward G. Neigut<br>(202) 426-9271    |
| <b>SPECIAL PLANNING STUDIES</b>  |            |             |                           |   |                                       |
| <b>Rapid Rail Transit Impact Studies</b>                                   |            |             |                           |   |                                       |
| Washington Metropolitan Area Transit Authority (WMATA) Impact Study        | DC-09-7001 | \$2,081,705 | May 1977-<br>Dec. 1983    | Metropolitan Washington (D.C.) Council of Governments | Richard Steinmann<br>(202) 426-4004   |
|  | DC-09-7002 |             |                           |   |                                       |
|  | DC-09-7003 |             |                           |   |                                       |
|  | DC-09-7004 |             |                           |   |                                       |
|  | DC-09-7005 |             |                           |   |                                       |
|  | DC-09-7008 |             |                           |   |                                       |
| Metropolitan Atlanta Rapid Transit Authority (MARTA) Impact Study          | IT-09-0086 | \$1,137,394 | Sept. 1977-<br>July 1983  | Atlanta (Ga.) Regional Commission                     | Richard Steinmann<br>(202) 426-4004   |
|  | IT-09-0097 |             |                           |   |                                       |
|  | GA-09-0037 |             |                           |   |                                       |
|  | GA-09-0038 |             |                           |   |                                       |
|  | GA-09-0063 |             |                           |   |                                       |
|  | GA-09-7001 |             |                           |   |                                       |
| San Diego Light Rail Transit Impact Study                                  | GA-09-7002 | \$202,320   | Aug. 1981-<br>April 1983  | San Diego (Calif.) Association of Governments         | Richard Steinmann<br>(202) 426-4004   |
|  | GA-09-0057 |             |                           |   |                                       |
|  | CA-09-7006 |             |                           |   |                                       |

## Planning and Analysis

| PROJECT TITLE  | NUMBER                                 | FUNDING   | SCHEDULE                  | AGENCY/<br>CONTRACTOR  | TECHNICAL<br>CONTACT                |
|--|--|-----------|---------------------------|--|-------------------------------------|
| <b>SPECIAL PLANNING STUDIES (CONT.)</b>  |  |           |                           |  |                                     |
| <b>Transportation System Management Planning (TSM)</b>                           |  |           |                           |  |                                     |
| Evaluation of TSM Implementation Experiences and Project Impacts                 | NY-09-9001                             | \$212,000 | Sept. 1979-<br>March 1982 | Urbitran, Inc.   | Richard Steinmann<br>(202) 426-4004 |
| San Francisco Institutional TSM Program  | CA-09-0070<br>CA-09-7004<br>CA-09-9004 | \$96,000  | June 1978-<br>Jan. 1982   | Metropolitan Transportation Commission, San Francisco, Calif.  | Richard Steinmann<br>(202) 426-4004 |
| Integrating TSM Consideration into the Long Range Planning Process               | TX-09-0181                             | \$51,200  | Sept. 1981-<br>Sept. 1982 | North Central Texas Council of Governments                     | Richard Steinmann<br>(202) 426-4004 |
| TSM in Neighborhoods: Involving Citizens in the Planning Process                 | DC-09-7006                             | \$136,000 | July 1982-<br>July 1984   | District of Columbia DOT                                       | Richard Steinmann<br>(202) 426-4004 |
| Strategic Planning at Transit Operators  | DC-09-7007                             | \$162,750 | Sept. 1982-<br>Sept. 1984 | WMATA  | Richard Steinmann<br>(202) 426-4004 |
| <b>Planning Transportation For Elderly And Handicapped People</b>                |  |           |                           |  |                                     |
| Data Collection System for Planning Services for Elderly and Handicapped Persons | IT-09-9009<br>DC-09-9049               | \$305,000 | Nov. 1977-<br>Dec. 1983   | Peat, Marwick, Mitchell and Co.                                | Richard Steinmann<br>(202) 426-4004 |
| Data Collection System Trials  | OH-09-7001                             | \$121,360 | July 1979-<br>July 1981   | Montgomery-Greene County Transportation Planning Program, Ohio | Brian E. McCollom<br>(202) 426-9271 |
| Development of Unified Billing and Accounting Systems for Special Services       | MI-09-7001                             | \$100,000 | Feb. 1981-<br>July 1983   | Michigan DOT   | Norman Paulhus<br>(202) 426-4208    |
| Analysis of Existing Elderly and Handicapped Services                            | IT-09-9006<br>CA-09-9003               | \$264,248 | Sept. 1977-<br>Sept. 1981 | National Institute for Advanced Studies                        | Richard Steinmann<br>(202) 426-4004 |

## Planning and Analysis

| PROJECT TITLE   | NUMBER   | FUNDING   | SCHEDULE                  | AGENCY/<br>CONTRACTOR   | TECHNICAL<br>CONTACT                |
|---|--|-----------|---------------------------|---|-------------------------------------|
| <b>SPECIAL PLANNING STUDIES (CONT.)</b>                                   |  |           |                           |   |                                     |
| <b>Planning Transportation For Elderly And Handicapped People (Cont.)</b> |  |           |                           |   |                                     |
| Planning for the Phase-In<br>of Accessible Buses                          | IT-09-9010<br>AZ-09-7001<br>TX-09-7002               | \$410,000 | May 1978-<br>Jan. 1981    | Booz, Allen and<br>Hamilton, Inc.;<br>City of Phoenix<br>Ariz.; Dallas (Tex.)<br>Transit System | Brian E. McCollom<br>(202) 426-9271 |
| <b>Energy Planning Studies</b>  |  |           |                           |   |                                     |
| Dallas-Fort Worth<br>Energy Contingency<br>Planning Prototype<br>Study    | TX-09-7001<br>TX-09-9003                             | \$80,000  | June 1978-<br>Feb. 1982   | North Central Texas<br>Council of Govern-<br>ments  | Richard Steinmann<br>(202) 426-4004 |
| Seattle Metro Transit<br>Operations Energy<br>Planning Prototype          | WA-09-0034   | \$222,463 | July 1980-<br>July 1982   | Municipality of<br>Metropolitan<br>Seattle, Wash.   | Richard Steinmann<br>(202) 426-4004 |
| Guidance for Transit<br>Operators on Energy Issues                        | DC-09-9035<br>DC-09-9044                             | \$20,000  | Sept. 1981-<br>Feb. 1983  | Cabot Consulting<br>Group   | Richard Steinmann<br>(202) 426-4004 |
| New York State Energy<br>Conservation Technical<br>Guidance Study         | NY-09-8006   | \$375,000 | July 1980-<br>July 1983   | New York State<br>DOT   | Richard Steinmann<br>(202) 426-4004 |
| <b>Short-Range Transit Planning</b>                                       |  |           |                           |   |                                     |
| Bus System Monitoring<br>System   | IT-09-9008   | \$300,000 | Jan. 1978-<br>Sept. 1983  | Multisystems, Inc.;<br>ATE Management and<br>Service Co.  | Brian E. McCollom<br>(202) 426-9271 |
| Bus System Monitoring<br>System Trials                                    | IL-09-7001<br>IL-09-7002<br>MN-09-7002<br>MN-09-7004 | \$503,164 | April 1979-<br>Sept. 1983 | CTA, Chicago, Ill.;<br>N.E. Illinois RTA;<br>Metropolitan Transit<br>Commission, Minn.          | Brian E. McCollom<br>(202) 426-9271 |
| Transit Surveillance<br>Prototype Study:<br>Boston, Mass.                 | MA-09-7001   | \$130,400 | June 1978-<br>Jan. 1983   | MBTA  | Brian E. McCollom<br>(202) 426-9271 |
| Service Evaluation<br>Prototype Study                                     | TX-09-0158   | \$60,000  | March 1981-<br>Dec. 1982  | Houston (Tex.)<br>MTA   | Brian E. McCollom<br>(202) 426-9271 |



## Planning and Analysis

| PROJECT TITLE   | NUMBER                   | FUNDING   | SCHEDULE                 | AGENCY/<br>CONTRACTOR  | TECHNICAL<br>CONTACT                |
|---|--------------------------|-----------|--------------------------|--|-------------------------------------|
| <b>SPECIAL PLANNING STUDIES (CONT.)</b>                                 |                          |           |                          |  |                                     |
| <b>Short-Range Transit Planning (Cont.)</b>                             |                          |           |                          |  |                                     |
| Transit Surveillance<br>Prototype Study:<br>Albany, N.Y.                | NY-09-0059               | \$48,000  | May 1980-<br>Jan. 1983   | Capital District<br>Transportation<br>Authority,<br>Albany, N.Y. | Brian E. McCollom<br>(202) 426-9271 |
| Transit Surveillance<br>Prototype Study:<br>Bridgeport, Conn.           | NY-09-0064               | \$54,199  | June 1980-<br>Jan. 1983  | GBTD   | Brian E. McCollom<br>(202) 426-9271 |
| Rail Transit Performance<br>Indicators and Evaluation<br>System Study   | DC-09-0007               | \$136,400 | March 1981-<br>May 1983  | WMATA  | Brian E. McCollom<br>(202) 426-9271 |
| Course in Transit<br>Operations and Planning                            | IT-09-9011               | \$247,405 | Sept. 1978-<br>July 1983 | Booz, Allen and<br>Hamilton, Inc.                                | Brian E. McCollom<br>(202) 426-9271 |
| Cost Estimation<br>Techniques for Bus<br>Service Planning               | IT-09-9014<br>MN-09-7003 | \$175,000 | April 1979-<br>Dec. 1982 | Booz, Allen and<br>Hamilton, Inc.                                | Brian E. McCollom<br>(202) 426-9271 |
| Route Patronage Modeling<br>Prototype Study:<br>Cleveland, Ohio         | OH-09-7002               | \$60,000  | Sept. 1979-<br>May 1983  | Greater Cleveland<br>(Ohio) RTA                                  | Brian E. McCollom<br>(202) 426-9271 |
| Route Patronage Modeling<br>Prototype Study:<br>Los Angeles, Calif.     | CA-09-0099               | \$20,000  | July 1980-<br>May 1983   | SCRTD  | Brian E. McCollom<br>(202) 426-9271 |
| Route Patronage<br>Modeling Prototype<br>Study: Portland, Oreg.         | OR-09-7001               | \$60,000  | July 1980-<br>May 1983   | TRIMET   | Brian E. McCollom<br>(202) 426-9271 |
| Route Patronage<br>Modeling Prototype<br>Study: Albuquerque,<br>N. Mex. | MN-09-0011               | \$50,000  | June 1981-<br>May 1983   | Albuquerque<br>(N. Mex.) Transit<br>System                       | Richard Steinmann<br>(202) 426-4004 |
| Route Patronage<br>Modeling Technical<br>Assistance                     | MA-09-9009<br>MA-09-9013 | \$550,000 | March 1980-<br>Jan. 1983 | TSC  | Brian E. McCollom<br>(202) 426-9271 |
| Maintenance Facilities<br>Planning Guides                               | IT-09-9018               | \$150,000 | May 1980-<br>Dec. 1983   | S.G. Associates  | Brian E. McCollom<br>(202) 426-9271 |

## Planning and Analysis

| PROJECT TITLE  | NUMBER                                 | FUNDING   | SCHEDULE                  | AGENCY/<br>CONTRACTOR  | TECHNICAL<br>CONTACT                |
|--|--|-----------|---------------------------|--|-------------------------------------|
| <b>SPECIAL PLANNING STUDIES (CONT.)</b>                          |  |           |                           |  |                                     |
| <b>Short-Range Transit Planning (Cont.)</b>                      |  |           |                           |  |                                     |
| Modeling the Cost of<br>Alternative Labor<br>Contract Provisions | CA-09-0109                             | \$67,200  | June 1981-<br>Dec. 1982   | SCRTD  | Brian E. McCollom<br>(202) 426-9271 |
| Management Planning<br>Prototype Studies                         | UT-09-0015<br>MO-09-0034<br>PA-09-7003 | \$280,000 | Sept. 1981-<br>March 1983 | Utah Transit<br>Authority; Kansas<br>City, (Mo.) Area<br>Transit Authority;<br>PAT | Brian E. McCollom<br>(202) 426-9271 |
| Planning Methods for<br>Allocation of Transit<br>Subsidies       | IT-09-9019                             | \$50,000  | Sept. 1981-<br>Dec. 1982  | To Be Determined   | Richard Steinmann<br>(202) 426-4004 |
| Transit Investment<br>Analysis                                   | CA-09-7008                             | \$20,000  | Sept. 1981-<br>March 1982 | Metropolitan<br>Transportation<br>Commission, San<br>Francisco, Calif.             | Brian E. McCollom<br>(202) 426-9271 |

### Bibliography

A list of recent reports follows. Please consult previous editions of this Directory for earlier reports. If available, a document number assigned by the National Technical Information Service (NTIS) is listed. Reports may be obtained from NTIS by using the order blanks provided at the end of this document.

Reports which have not been assigned an NTIS number may not have been published in sufficient quantity for general distribution. Single copies and other information may be available from the issuing agency or organization.

Single copies of reports marked with an asterisk (\*) are available by sending a self-addressed mailing label to:

Technology Sharing Program (I-30)  
Office of the Secretary of  
Transportation  
Washington, D.C. 20590

Additional reports relating to the research described in this chapter may become available in the near future. For the most recent information or suggestions for additional reference materials regarding specific projects, call or write to the person listed as the technical contact in the Project Summary Table.

### TRANSPORTATION PLANNING ANALYSIS METHODS

**The Urban Transportation Planning System: An Introduction for Management**  
Proj. DC-06-0187  
UMTA; Public Technology, Inc.  
1980

#### UTPS Software Package

(Computer Tape)  
UPM-20, Office of Planning Methods and Support  
UMTA  
1979 (With Revisions through June 1981)

**Characteristics of Urban Transportation Supply (CUTS)**

(Also on UTPS Computer Tape)  
Proj. IT-06-0049  
DeLeuw Cather and Company  
1979, PB 233-580

**Characteristics of Urban Transportation Demand (CUTD): A Handbook for Transportation Planners**

Proj. IT-06-0049  
Wilbur Smith and Associates  
April 1978, PB 293-220

**Characteristics of Urban Transportation Demand (CUTD) Appendix**

Proj. IT-06-0049  
Wilbur Smith and Associates  
January 1979, PB 294-989

**\*Traveler Response to Transportation System Changes**

UPM-20, Office of Planning Methods and Support  
UMTA; R.H. Pratt  
1981 Update, PB 265-830

**Analyzing Transit Options for Small Urban Communities**

**Vol. I, Transit Service Objectives and Options**

**Vol. II, Analysis Methods**

**Vol. III, Summary of Management and Operations Experience**

Proj. IT-06-9020  
Peat, Marwick, Mitchell and Company  
January 1978, PB 291-449, 450 and 451

**Simplified Aids for Transportation Analysis**

**Vol. I, Annotated Bibliography**

**Vol. II, Forecasting Auto Availability and Travel**

**Vol. III, Estimating Ridership and Cost**

**Vol. IV, Transit Route Evaluation**

**Vol. V, Estimating Parking Accumulation**

**Vol. VI, Fringe Parking Site Requirements**

Proj. IT-06-9020  
Peat, Marwick, Mitchell and Company  
1979, PB 299-980 through 985

**An Introduction to Travel Demand Forecasting: A Self-Instructional Text**  
UPM-20, Office of Planning Methods and Support  
UMTA; FHWA  
1978

**Transit Corridor Analysis: A Manual Sketch Planning Technique**

Proj. MD-06-0046  
Alan M. Voorhees, Inc.; DeLeuw Cather and Company; R.H. Pratt; COMSIS Corp.  
April 1979, PB 301-378

**Transportation Air Quality Analysis: Sketch Planning Methods**

**Vol. I, Analysis Methods**

**Vol. II, Case Studies**

Proj. DC-06-0273  
UMTA; EPA; Cambridge Systematics, Inc.  
1979, PB 80-158-702

**Transit Network Analysis: INET**

(Five Tutorial Documents)  
UPM-20, Office of Planning Methods and Support  
UMTA  
1979, UMTA-UPM-20-79-3

**Highway Sketch Planning: CAPM**

UPM-20, Office of Planning Methods and Support  
UMTA; FHWA  
1979, UMTA-UPM-20-79-2

**Urban Transportation Planning System Lexicon**

Proj. MD-06-0049  
Rock Creek Associates; Price, Williams and Associates  
1981, UMTA-UPM-20-81-1

**Sources of Information on Urban Transportation Planning Methods**

URT-41, Office of Methods and Support  
UMTA; FHWA  
March 1983

**TRANSIT OPERATIONS ANALYSIS METHODS**

*Fixed Route Operations*

**Microcomputers in Transportation: Software and Source Book**

URT-41, Office of Methods and Support  
UMTA; FHWA  
January 1983

**Microcomputers in Transportation: Getting Started in Microcomputers, Selected Readings, Vol. II**

URT-41, Office of Methods and Support  
UMTA; FHWA  
(No Date)

**Time Capsules:**

**Newsletter of the Transit Industry Microcomputer Exchange**

Proj. NY-06-0090  
Rensselaer Polytechnic Inst.  
(Periodically Issued)

**Micro Scoop:**

**Microcomputers in Transportation User Group Newsletter**

Transportation Systems Center  
(Periodically Issued)

*Paratransit Operations*

**Benefit-Cost Analysis of Integrated Paratransit Systems**

**Vol. I, Executive Summary**

PB 80-125-479

**Vol. II, Introduction and Framework for Analysis**

PB 80-125-487

**Vol. III, Scenario Analyses**

PB 80-125-495

**Vol. IV, Issues in Community Acceptance and Integrated Paratransit Implementation**

PB 80-125-503

**Vol. V, The Impacts of Technological Innovation**

PB 80-125-511



**Vol. VI, Technical Appendixes**

PB 80-124-529

Proj. MA-06-0054

Multisystems, Inc.

September 1978, PB 80-125-461 (complete set)

**Paratransit Integration, Model Review and Requirements**

Proj. MA-06-0054

SYSTAN, Inc.

July 1979, DOT-TSC-1392

**Paratransit Integration, State-of-the-Art Report**

Proj. MA-06-0054

SYSTAN, Inc.

December 1978, DOT-TSC-1392

**Paratransit Handbook**

**Vol. I**

**Vol. II**

Proj. MA-06-0054

SYSTAN, Inc.

February 1979, PB 81-222-127 and 135

**SPECIAL PLANNING STUDIES**

***Rapid Rail Transit Impact Studies***

**\*Rail Rapid Transit Impact Studies:**

**Atlanta, Washington, San Diego**

Price, William and Associates

March 1982, DOT-I-82-3

**\*BART in the San Francisco Bay Area:**

**Final Report of the BART Impact Program**

Proj. CA-09-0025, CA-09-0042,

DOT-OS-30-176

Metropolitan Transportation Commission

June 1979, DOT-BIP-FR-9-201-78

**\*BART Impact Program Reports**

DOT-OS-30-176

Metropolitan Transportation Commission

**The Economic and Financial Impacts of BART**

DOT-P-30-79-09

**Environmental Impacts of BART**

DOT-P-30-79-05

**Impacts of BART on Bay Area Institutions and Lifestyles**

DOT-P-30-79-06

**The Impact of BART on Public Policy**

DOT-P-70-79-07

**BART's First Five Years: Transportation and Travel Impacts**

DOT-P-30-79-08

**Land Use and Urban Development Impacts of BART**

DOT-P-30-79-09

**The Local Implications of BART Development**

DOT-P-30-79-11

**Implications of BART's Impacts for the Transportation Disadvantaged**

DOT-P-30-79-12

April 1979

**Silver Springs Metro Before and After Study**

Proj. IT-09-0097

JHK and Associates

January 1979

**More Than A Subway: A Chronicle of Transit Goals for the Nation's Capital**

Proj. IT-09-0086

Metropolitan Washington Council of Governments

April 1979, UMTA-IT-09-0086-79-1

**Indicators for Determining the Impact of Metro Rail**

Proj. DC-09-7002

Peat, Marwick, Mitchell and Company

July 1980

**\*The First Four Years of Metro Rail: Travel Changes**

Proj. DC-09-7004

Metropolitan Washington Council of Governments

September 1981, UMTA-DC-09-7004-81-1

**\*Trends Before Metrorail**

Proj. DC-09-7005

Metropolitan Washington

Council of Governments

July 1982, DOT-I-82-33

**Transit Impact Monitoring Program: Results of East Line Pilot Project 1970-1976**

**Executive Summary**

**Technical Appendix**

Proj. GA-09-0038

Atlanta Regional Commission

April 1978

**Transit Impact Monitoring Program: Employment and the Station Areas 1970-1975**

Proj. GA-09-0038

Atlanta Regional Commission

November 1978

**Transit Impact Monitoring Program: Commercial Land Impacts**

Proj. GA-09-0038

Atlanta Regional Commission

December 1978

**Transit Impact Monitoring Program: Station Area Profiles**

Proj. GA-09-0038

Atlanta Regional Commission

December 1978

**Transit Impact Monitoring Program: Residential Land Monitoring**

Proj. GA-09-0038

Atlanta Regional Commission

December 1978

**Transit Impact Monitoring Program: Decatur Case Study**

Proj. GA-09-0038

Atlanta Regional Commission

December 1978

**Transit Impact Monitoring Program: Public Improvements in Station Areas**

Proj. GA-09-0038

Atlanta Regional Commission

December 1978

**Transit Impact Monitoring Program:  
Summary of 1978 Work**

Proj. GA-09-0038  
Atlanta Regional Commission  
January 1979

**Transit Impact Monitoring Program:  
MARTA Residential Displacement and  
Relocation Activity, August 1973 through  
March 1978**

Proj. GA-09-7001  
Atlanta Regional Commission  
April 1979

**Transit Impact Monitoring Program:  
Transportation System Conditions  
1970-1977**

Proj. GA-09-7001  
Atlanta Regional Commission  
April 1979

**Transit Impact Monitoring Program:  
Annual Report 1979**

Proj. GA-09-7001  
Atlanta Regional Commission  
December 1979

**Transit Impact Monitoring Program:  
Annual Report 1980**

Proj. GA-09-7002  
Atlanta Regional Commission  
December 1980

**Transit Impact Monitoring Program:  
Results of Station Area Studies**

Proj. GA-09-0057  
Atlanta Regional Commission  
August 1981

**Transit Impact Monitoring Program:  
A Preliminary Analysis of the Impact of  
MARTA's Omni Station on Omni  
International Atlanta**

Proj. GA-09-0057  
Atlanta Regional Commission  
December 1981

**\*Trends Before the San Diego Trolley**

Proj. CA-09-7006  
San Diego Association of Governments  
July 1982, DOT-I-82-40

***Transportation  
System Management Planning  
(TSM)***

**TSM Prototype Planning Study: Portland,  
Oreg.**

Proj. IT-09-0068  
Columbia Regional Association of  
Governments  
November 1979, PB 80-181-951

**\*TSM: Handbook of Manual Analysis  
Techniques for Transit Strategies  
(Dallas-Fort Worth)**

Proj. TX-09-0045  
North Central Texas Council of Governments  
May 1981, PB 81-210-361

**\*TSM for Major Institutions: San  
Francisco Experience**

Proj. CA-09-9004  
John Twitchell Associates  
December 1981, DOT-I-82-11

**\*Transportation System Management  
Implementation and Impact**

Proj. NY-09-9001  
Urbitran Associates  
March 1982, DOT-I-82-49

***Planning Transportation for  
Elderly and Handicapped  
People***

**Planning for the Phase-in of Fixed-Route  
Accessible Buses—Interim Report  
No. 1: Review of Accessible Transit  
Services**

Proj. IT-09-9010  
Booz, Allen and Hamilton, Inc.  
January 1980, PB 80-184-146

**\*Planning for the Phase-In of Fixed-Route  
Accessible Buses**

Proj. IT-09-9010  
Booz, Allen and Hamilton, Inc.  
February 1982, DOT-I-82-22

**Self-Identification Techniques: A Model  
System for Tacoma, Wash.**

Proj. WA-09-7001  
Tacoma Transit  
August 1979, UMTA-WA-09-7001-79-1

**Elderly and Handicapped Data  
Collection: San Diego, Calif.**

Proj. CA-09-7001  
San Diego Association of Governments

**Elderly and Handicapped Data Collection  
Study: Draft Final Report—Dayton  
Telephone Survey of Transportation  
Handicapped Persons: Design,  
Administration, and Analysis of Results**

Proj. IT-09-9009  
Peat, Marwick, Mitchell and Company  
June 1981

**Implementation Guidelines for  
Coordinated Agency Transportation  
Services**

Proj. DC-09-9006, DC-09-9013  
U.S. Department of Health and Human  
Services  
April 1980

**\*Handicapped Planning: Wisconsin  
Coordination Manual**

Proj. WI-09-8006  
Wisconsin Department of Transportation  
December 1980, DOT-I-81-16

**Special Paratransit Service for Elderly  
and Handicapped Persons  
Vol. I, Operational Experience**

Proj. CA-09-9003  
Ned Einstein  
October 1981, PB 82 177-650  
Available from GPO, 050-000-00216.1

**\*Special Paratransit Service for Elderly  
and Handicapped Persons  
Vol. II, Decision Manual for System  
Design**

Proj. CA-09-9003  
Ned Einstein  
October 1981, PB 82 219-197

## ***Energy Planning Studies***

### **Transportation Energy Contingency Planning: Local Experiences**

Proj. TX-09-9001  
FHWA; UMTA  
June 1979, UMTA-TX-09-9001-79-1

### **Transportation Energy Contingency Strategies: Transit, Paratransit, and Ride Sharing**

#### **Vol. I, Planning Process Roles and Responsibilities**

#### **Vol. II, Synopsis of Actions**

#### **Vol. III, The Case of the "Yourtown" Urbanized Area**

Massachusetts Institute of Technology  
August 1980

### **Transportation Energy Contingency Plan for the Kansas City Metropolitan Region**

Proj. MO-09-7001  
Mid America Regional Council  
February 1980, UMTA-MO-09-7001-81-1

### **\*Transportation Energy Contingency Planning: Taxi and School Bus Use in Dallas-Fort Worth**

Proj. TX-09-9003  
William G. Barker and Associates  
August 1982, DOT-I-82-38

### **\*Transportation Energy Contingency Planning: Transit Fuel Supplies Under Decentralization**

Proj. DC-09-9035  
Cabot Consulting Group  
May 1982, DOT-I-82-20

### **\*Transportation Energy Contingency Planning: A Guide for Transit Operators**

Proj. WA-09-0034  
Municipality of Metropolitan Seattle  
April 1982, DOT-I-82-12

### **Energy Impacts of Transportation Systems Management Actions**

Proj. NY-09-8006  
New York State Department

of Transportation  
October 1981, PB 82-237-124

## ***Short-Range Transit Planning***

### **Bus Service Evaluation Procedures: A Review**

Proj. MA-09-7001, VA-09-7001  
Massachusetts Bay Transportation Authority;  
Tidewater Transportation District Commission  
April 1979, PB 296-314

### **Prototype Bus Service Evaluation System: Tidewater Transportation District Commission**

Proj. VA-09-7001  
Tidewater Transportation District Commission  
April 1981, UMTA-VA-09-7001-81-1

### **Transit Service Evaluation: Berkshire RTA**

Proj. MA-09-0050  
Berkshire Regional Transit Authority  
October 1979, UMTA-MA-09-0050-80-1

### **\*Statewide Transit Evaluation in Michigan**

Proj. MI-09-8004  
Michigan Department of Transportation  
July 1981, UMTA-MI-09-8004-81-1

### **Bus Transit Monitoring Study: Data Requirements and Collection Techniques**

Proj. IT-09-9008  
Multisystems, Inc.; ATE Management and Service Company  
April 1979, PB 80-161-409

### **\*Bus Transit Monitoring Manual Vol. I, Data Collection Program Design Vol. II, Sample Size Tables**

Proj. IT-09-9008  
Multisystems, Inc.; ATE Management and Service Company  
August 1981, PB 82-122-227,235  
Available from GPO, 050-000-00207.1

### **\*An Assessment of Automatic Passenger Counters**

Proj. IT-09-9008  
Multisystems, Inc.  
September 1982, DOT-I-82-43

### **Route Level Demand Models: A Review**

Proj. MA-09-9009  
Multisystems, Inc.  
January 1982, PB 82 237-842

### **Bus Route Costing Procedures: A Review**

Proj. IT-09-9014  
Booz, Allen and Hamilton, Inc.  
May 1981, PB 82 105-198  
Available from GPO, 050-000-00203-9

### **Transit Operations Planning: Existing Training Courses**

Proj. IT-09-9011  
Booz, Allen and Hamilton, Inc.  
July 1981, UMTA-IT-09-9011-81-1

### **Management Planning: Wisconsin Insurance Study**

Proj. WI-09-8004  
Warren, McVeigh and Griffin for Wisconsin Department of Transportation  
May 1980, UMTA-WI-09-8004-81-1

### **\*Savings on Bus Insurance In Wisconsin**

Warren, McVeigh and Griffin  
March 1982, DOT-I-82-19

### **\*Bus Scheduling Manual: Traffic Checking and Schedule Preparation**

American Transit Association  
August 1947, reprinted July 1982,  
DOT-I-82-23



# Management Resources

---

## Trends and Highlights



In the field of management resources, UMTA's projects are designed to improve the internal management of the nation's mass transit systems, and to contribute to a more efficient and more productive operation. They include development of a wide range of instructional courses for both blue collar and professional transit employees, design and deployment of maintenance training materials, and development of operations and maintenance systems.

Human resource projects authorized by Section 6 focus on research into industry-identified personnel problems, and on the development of new approaches and training courses for adoption by the industry. New initiatives are being undertaken to include input from labor leadership in projects dealing with increased worker performance and productivity.

Managerial training is authorized by Section 10 of the Urban Mass Transportation Act. This component of the Transportation Act authorizes UMTA to provide grants to local agencies to assist in the training of managerial, technical and professional personnel. It is described in the second section of this chapter.

The activities described in this chapter are by no means a comprehensive listing of UMTA-supported training. Short-term technical training is most frequently offered as an integral part of programs for the introduction of improved service methods, planning methods, or new equipment and facilities. The University Research and Training Program, authorized by Section 11 of the Act, is described in Chapter 11.

## Human Resources Development

Activities included in UMTA's Human Resources Program in FY 82 reflected a new effort to include input from labor on projects dealing with increased worker performance and productivity. Projects in Miami, Fla. (FL-06-0031), and Philadelphia, Pa. (PA-06-0072), involved labor union representation in both developmental and implementation stages.

In Philadelphia, the Southeastern Pennsylvania Transportation Authority (SEPTA) is developing a set of classroom and shop training materials for use by the entire bus maintenance staff. In Miami, plans have been made to coordinate all training and development activities of the Metropolitan Dade County Transportation Agency as a means to upgrade the performance of both salaried and hourly personnel.

Work is continuing on a major project in the San Francisco area concerning bus operator stress and hypertension problems (CA-06-0160). This piece of foundation research will provide valuable insight into worker disability, absenteeism, and other symptoms of low performance and productivity.

Regional workshops continued to disseminate UMTA generated material on Handicapped Employment Practices, in cooperation with Harold Russell Associates (MA-06-0105). The Transportation Systems Center conducted workshops on Bus Operator Training (MA-06-0135), using materials developed by the AFL-CIO Appalachian Council (WV-06-0011). Through a contract to Urban Resources Inc. (IT-06-0231), productivity workshops



***The National Transit Labor/Management Relations Conference, held in Miami in September 1982, began a new initiative on the part of UMTA to assist in improving this important factor in public transportation.***

were also conducted and modified to meet the needs of smaller transit agencies.

UMTA, in cooperation with transit labor and management, developed and conducted a National Transit Labor/Management Relations Conference in Miami, Fla., sponsored by Florida International University (FL-06-0030). This conference will be held annually, providing labor, management and government with a forum for solving common problems affecting the future of transit.

## Management Training Courses

As authorized by Section 10 of the Urban Mass Transportation Act, UMTA provides grants to state and local public bodies to assist in the training and development of managerial, technical and professional personnel employed in public transportation. During a period of spiraling costs, increased operating deficits and changing technology, the demand for





***UMTA is supporting research on bus operator stress and hypertension hazards. In addition to the human toll, these problems lower the productivity of the nation's transit systems.***

trained, competent personnel is increasing. Requirements for improved transit performance and productivity mandate that human resources be upgraded through training and development.

UMTA provides financial assistance for transit personnel attendance at UMTA endorsed training courses in order to stimulate training and training program development among transit operators. This in turn encourages transit agencies to make a commitment to managerial and technical personnel development and insures that effective training takes place on a locally determined basis.

Each year for the past decade, over 100 managerial employees of the U.S. transit industry have benefited from residential courses of study. These courses have been from two to six weeks in duration, and have involved extensive classroom work, coupled with discussions and seminar activity. In 1981, the program was expanded to encompass approximately a dozen courses, located at schools and agencies across the nation. In addition, a block grant activity was inaugurated in Section 10 whereby a grant is awarded to a specific transit agency to fund a number of managerial training pro-

grams which are important to the agency's development.

The establishment in 1982 of the University Centers for Transit Research and Management Development added a new dimension to the management training program. Funds were made available under Section 11 to the Centers to provide an academic base for developing educational opportunities in management and to expand the scope and number of training activities for transportation professionals. A variety of Section 10 endorsed short courses and other training activities are offered by the Centers to the transit industry.

A list of UMTA endorsed management training course providers appears below. Individual employees interested in furthering their professional development should contact the providers for detailed information on specific courses offered, fellowship eligibility and Section 10 grant application forms. Upon acceptance into a course, the agency by which the student is employed submits the grant application to UMTA; grant awards are made directly to the agency. Section 10 grants may cover up to 75 percent of course-related costs.

### **Management Training Course Providers**

University of California at Irvine  
Contact: Dr. G.J. Fielding,  
(714) 833-5448

New York Institute of Technology  
Contact: Dr. Richard Dibble,  
(516) 686-7722

Portland State University  
Contact: Dr. Kenneth Dueker,  
(503) 229-4043



Texas Southern University  
Contact: Dr. Naomi Lede  
(713) 527-7282

Florida A&M University  
Contact: Mr. Addis Taylor  
(904) 599-3600

University of Michigan  
Contact: Dr. George Gamota  
(313) 764-6200

University of Pennsylvania  
Contact: Dr. Howard Mitchell  
(215) 898-7818

Indiana University  
Contact: Dr. George Smerk  
(812) 335-8143

Cleveland State University  
Contact: Ms. Janel Eadie  
(216) 687-2134

National Mass Transit Institute  
Contact: Dr. William Montgomery  
(412) 237-7322

Northeastern University  
Contact: Dean Malcolm Campbell  
(617) 890-1134

University of Wisconsin-Milwaukee  
Contact: Dr. Edward Beimborn  
(414) 963-4978

Consult Limited  
Contact: Mr. Edward Kazemek  
(312) 346-1567

University of Southern California  
Contact: Robert M. Brown, Jr.  
(213) 743-4046

University of North Florida  
Contact: Kevin Horn  
(904) 646-2860

Polytechnic Institute of New York  
Contact: Dr. Roger P. Roess  
(212) 643-5526

University of Tennessee  
Contact: Dr. Kenneth Heathington  
(615) 974-5255

University of Washington  
Contact: Dr. Jerry Schneider  
(206) 543-8678

## Operations and Maintenance Support

One of the promising new projects aimed at improving productivity is the development and evaluation of an Automatic Bus Diagnostic System (IT-06-0102). The demonstration has been completed and the evaluation report, now in preparation, will be published in May 1983.

Another project, Maintenance Manual Specification (IT-06-0235), developed criteria for maintenance manuals, or job performance aids, to improve maintenance productivity and reduce repair errors. Based on these specifications, a companion project (MI-06-0023) is developing a maintenance manual for a particular bus model and testing its effects in a real maintenance environment.

A computer software project entitled RUCUS-II Development (MA-06-0046) produced a software system providing transit operators with an improved auto-



**Management Performance Auditing was the subject of this management training seminar at Indiana University.**

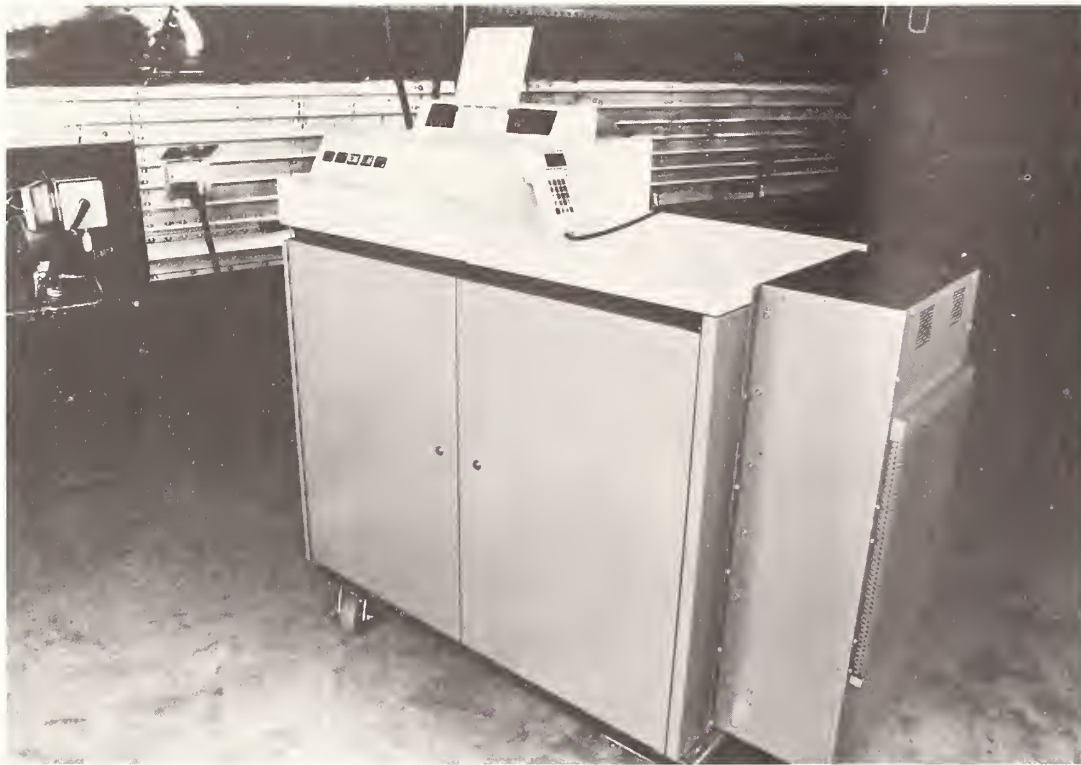

Development of a Transit Management Incentive Contract (IT-06-0246) is a project to develop and evaluate various incentive contract arrangements for transit systems entering into contract management. A final report is expected in 1983.

***The Automatic Bus Diagnostic System utilizes a computer to give readings on bus fluid pressures and the electrical system. Such information can increase operating effectiveness and reduce costs by helping to prevent major bus repairs.***

ated system for vehicle scheduling and driver run-cutting. The RUCUS-II system applies advances in computer hardware and software within an interactive framework to provide greater control of the entire scheduling process, more efficient processing, and increased effectiveness.

The RUCUS-II Test Deployment and Evaluation project (PA-06-0065) will conduct a rigorous testing and evaluation of the RUCUS-II system prior to a general industry release. The demonstration will involve operations from four garages, housing a total of some 500 buses, within the

Southeastern Pennsylvania Transit Authority operation.

The Service, Inventory and Maintenance System (SIMS) Demonstration (MI-06-0021) is a project to enhance bus maintenance practices through the development and testing of a bus servicing system. This system integrates the service module of SIMS with an automated data collection system for capturing vehicle fuel, oil, torque fluid, and coolant usage information. The project has been completed and a project report will be available in May 1983.



*UMTA is investigating the use of microcomputers to help smaller agencies achieve savings in such areas as parts inventory, engine life, and employee assignments.*



## Management Resources

| PROJECT TITLE                                     | NUMBER     | FUNDING     | SCHEDULE                  | AGENCY/<br>CONTRACTOR                               | TECHNICAL<br>CONTACT                      |
|---|------------|-------------|---------------------------|---|---|
| <b>HUMAN RESOURCES DEVELOPMENT</b>                |            |             |                           |   |   |
| Human Resources Mgmt.<br>Demonstration            | FL-06-0031 | \$362,159   | May 1982-<br>May 1984     | Miami-Dade<br>County<br>Transportation<br>Authority | Charles T. Morison, Jr.<br>(202) 426-0080 |
| Maintenance Training<br>Demonstration             | PA-06-0072 | \$600,000   | July 1982-<br>June 1984   | SEPTA   | Charles T. Morison, Jr.<br>(202) 426-0080 |
| Bus Operator Stress/<br>Hypertension Project      | CA-06-0160 | \$150,000   | Aug. 1981-<br>Ongoing     | Regents of<br>University of<br>California           | Alice Royal<br>(202) 426-0080             |
| Employment of the<br>Handicapped                  | MA-06-0105 | \$305,000   | July 1980-<br>Ongoing     | Harold Russel<br>Associates, Inc.                   | Alice Royal<br>(202) 426-0080             |
| Transit Industry Employee<br>Training Program     | WV-06-0011 | \$3,500,000 | April 1977-<br>Dec. 1981  | AFL-CIO<br>Appalachian<br>Council, W. Va.           | Charles T. Morison, Jr.<br>(202) 426-0080 |
| Bus Operator Instructor<br>Training               | MA-06-0135 | \$150,000   | June 1981-<br>Ongoing     | TSC   | Charles T. Morison, Jr.<br>(202) 426-0080 |
| Productivity Workshop<br>Development              | IT-06-0231 | \$265,865   | May 1979-<br>June 1982    | Urban Resources,<br>Inc.                            | Alice Royal<br>(202) 426-0080             |
| Labor/Management Relations<br>Conference          | FL-06-0030 | \$65,000    | Feb. 1982-<br>Annual      | Florida Inter-<br>national University               | Charles T. Morison, Jr.<br>(202) 426-0080 |
| Absenteeism Reduction<br>Demonstration Project    | PA-06-0067 | \$180,000   | To Be<br>Determined       | PAT   | Alice Royal<br>(202) 426-0080             |
| Automated Technical/<br>Testing Techniques        | CA-06-0123 | \$112,000   | June 1979-<br>Feb. 1982   | San Diego<br>(Calif.) Transit<br>Authority          | Charles T. Morison, Jr.<br>(202) 426-0080 |
| Bus Operator Testing<br>and Training              | IT-06-0252 | \$79,000    | Dec. 1979-<br>Jan. 1982   | Jordan-DeLaurenti,<br>Inc.                          | Frank E. Enty<br>(202) 426-9274           |
| Regional Training<br>Center                       | CA-06-0131 | \$459,216   | March 1980-<br>Sept. 1982 | SCRTD   | Charles T. Morison, Jr.<br>(202) 426-0080 |
| Transit Human Resources<br>Development Consortium | NY-06-0079 | \$200,900   | July 1980-<br>June 1982   | CENTRO  | Charles T. Morison, Jr.<br>(202) 426-0080 |
| Board Member Training                             | FL-06-0033 | \$77,032    | Sept. 1982-<br>June 1983  | University of<br>North Florida                      | Charles T. Morison, Jr.<br>(202) 426-0080 |

## Management Resources

| PROJECT TITLE  | NUMBER     | FUNDING     | SCHEDULE                 | AGENCY/<br>CONTRACTOR                        | TECHNICAL<br>CONTACT            |
|--|------------|-------------|--------------------------|--|---------------------------------|
| <b>OPERATIONS AND MAINTENANCE SUPPORT</b>                    |            |             |                          |  |                                 |
| Automatic Bus Diagnostic System                              | IT-06-0102 | \$700,000   | Dec. 1979-<br>June 1982  | Tri-State Regional Planning Commission, N.Y. | A. B. Hallman<br>(202) 426-9274 |
| Development and Demonstration of Bus Maintenance Repair Aids | MI-06-0023 | \$1,500,000 | Sept. 1979-<br>Ongoing   | City of Detroit, Mich.                       | A. B. Hallman<br>(202) 426-9274 |
| RUCUS II Test Deployment and Evaluation                      | PA-06-0065 | \$200,000   | Jan. 1982-<br>Ongoing    | TSC; SEPTA                                   | A. B. Hallman<br>(202) 426-9274 |
| Service, Inventory, and Maintenance (SIMS) Demonstration     | MI-06-0021 | \$200,000   | Sept. 1980-<br>Dec. 1981 | City of Detroit, Mich.                       | A. B. Hallman<br>(202) 426-9274 |
| Development of a Transit Management Incentive Contract       | IT-06-0246 | \$98,000    | Nov. 1981-<br>March 1983 | Booz, Allen and Hamilton, Inc.               | A. B. Hallman<br>(202) 426-9274 |

## Bibliography

A list of recent reports follows. Please consult previous editions of this Directory for earlier reports. If available, a document number assigned by the National Technical Information Service (NTIS) is listed. Reports may be obtained from NTIS by using the order blanks provided at the end of this document.

Reports which have not been assigned an NTIS number may not have been published in sufficient quantity for general distribution. Single copies and other information may be available from the issuing agency or organization.

Additional reports relating to the research described in this chapter may become available in the near future. For the

most recent information or suggestions for additional reference materials regarding specific projects, call or write to the person listed as the technical contact in the Project Summary Table.

### HUMAN RESOURCES DEVELOPMENT

#### **Public Transportation: An Element of the Urban Transportation System**

FHWA-TS-80-211

JHK and Associates

February 1980

#### **Study of Operator Absenteeism and Worker's Compensation Trends in the Urban Mass Transportation Industry**

Proj. PA-06-0050

Port Authority of Allegheny County;

Peat, Marwick, Mitchell and Company

March 1980, PB 81-180-937

#### **A Validation and Analysis of Selection Procedures for Male and Female Bus Operators**

Proj. MA-06-0011

Massachusetts Bay Transportation Authority;  
University of Chicago, Human Resources Center

April 1980, PB 80-222-011

#### **Handbook for Transit Internships Transit: The Way to Go in the 80's**

Proj. DC-06-0224

American Public Transit Association

April 1980, PB 82-120-405

#### **National Transit Intern Program: Final Report and Evaluation**

Proj. DC-06-0224

American Public Transit Association

June 1980, PB 82-120-411

**Guide to Employing Handicapped Persons  
in the Transit Industry**

Proj. MA-06-0105

Harold Russell Associates, Inc.

September 1981, UMTA-MA-06-0105-81-1

**Review and Evaluation of the Use of Bus  
Operator Testing Procedures in the  
Personnel Selection Process Within the  
Transit Industry**

Proj. IT-06-0252

Jordan-DeLaurenti, Inc.

December 1981

**OPERATIONS AND MAINTENANCE  
SUPPORT**

**Survey and Analysis of Bus Rehabilitation**

Proj. IT-06-0232

ATE Management and Service Company

November 1980, PB 81-178-501

**A Specification for Bus Maintenance  
Manuals**

Proj. IT-06-0235

XYZYX Corporation

November 1980, PB 81-178-352



# Information Services

## Trends and Highlights



UMTA's information services projects collect and publish statistical information on national transit for use by local officials, transit managers and other industry decision-makers in planning, managing and evaluating their operations. Other information services projects assist the industry by disseminating new information on management methods and technologies.

During FY 82 the third annual National Urban Mass Transportation Statistics report was prepared by UMTA's Office of Technical Assistance. These reports, known as *Section 15 Reports*, represent the first uniform listing of financial and operating data on transit operations nationwide. UMTA/industry exchanges are expected to result in further refinements and improvements for each subsequent report.

UMTA's program of communications and technology sharing is designed to accelerate the interchange of managerial and technical information within the transit community. During FY 82, emphasis was placed on the production of technical briefs and on the rapid dissemination of interim and less formal technical reports.

To make detailed technical information more accessible, UMTA has initiated the Urban Mass Transportation Information System (UMTRIS). UMTRIS is administered by the Transportation Research Board (TRB) and consists of a computer data base that indexes and abstracts the vast body of transit-related journals, articles, books, reports, statistical sources and computer programs produced worldwide.

## Section 15 Information

Section 15 of the Urban Mass Transportation Act requires beneficiaries of Section 5 and new Sections 9A and 9 operating and assistance grants to report operating and financial data for inclusion in a computerized reporting system. This system generates routine and ad hoc reports from the raw data. Using these reports as an aid, individual and comparative analyses can be performed with selected performance indicators.

A cooperative working arrangement has developed between the transit industry and the Federal Government on the Section 15 data collection and reporting system. The private and public sectors have recognized the importance of and need for timely and accurate data with which to assess the progress of the nation's mass transportation system. Grantees submit their reports to UMTA on an annual basis. This information is reviewed for accuracy and consistency (DC-06-0383) before being put into the data base. The data base is then translated into an annual report (MA-06-0107).

The first annual report, published for national distribution in 1981, covers transit financial and operating data reported for agency fiscal years ending between July 1, 1978 and June 30, 1979. Subsequent reports have been issued for FY 80 and FY 81. The Section 15 system performance is being objectively evaluated, and recommendations will be adopted by UMTA. In addition, an advisory committee with a membership reflecting user diversity is planned. This committee will address the transit industry's current information needs and applications. Scheduled meet-



**Section 15 information will allow for comparative and individual analyses of our mass transit systems.**

ings will be announced in the *Federal Register*.

A project with the Commonwealth of Massachusetts (MA-06-0018) will provide states with methods for using Section 15 data to measure performance of transit services and make peer comparisons. Another project (IT-06-0234) will provide Metropolitan Planning Organizations with tools that will ease the data collection burden associated with Section 15 reports. It will also enhance several aspects of the reporting system.

## Technical Information Services

For the transit industry to take advantage of improvements in management and technology, transit and local government personnel at many levels must be aware of the potential advantages as well as costs of innovations, and must exercise initiative to bring about change. This process often requires a considerable amount of information and other forms of technical assistance.



Although communications are an integral part of all technical assistance projects, some functions can best be performed centrally for UMTA as a whole. One such function is the dissemination of formal technical reports resulting from the various projects described in this directory. The UMTA Office of Technical Assistance regularly selects, abstracts and processes technical reports for inclusion in the National Technical Information Service (NTIS). The NTIS system, which distributes announcements, abstracts and reports nationally, assures that detailed technical information will be stored and kept available for researchers in public or private institutions.

To aid the technical community in locating relevant information, a project (DC-06-0285) has been funded for the TRB to maintain an Urban Mass Transportation Information Service (UMTRIS). This data base is part of the Transportation Research Information Service (TRIS), which covers all aspects of transportation. The TRIS on-line data base is accessible through Lockheed Information Systems' DIALOG as File 63. Batch-mode retrieval services are available through UMTRIS at the TRB Washington, D.C., office. The UMTRIS system was brought on line in FY 82 and a cumulative bibliography was published for the years 1974-1980.

To communicate more directly with transit agencies and local governments, UMTA maintains other projects designed to accelerate the two-way flow of information on near-term technical and management problems and solutions. The Technology Sharing Project (MA-06-0086) helps UMTA familiarize industry with its technical assistance programs through workshops and publications such as this

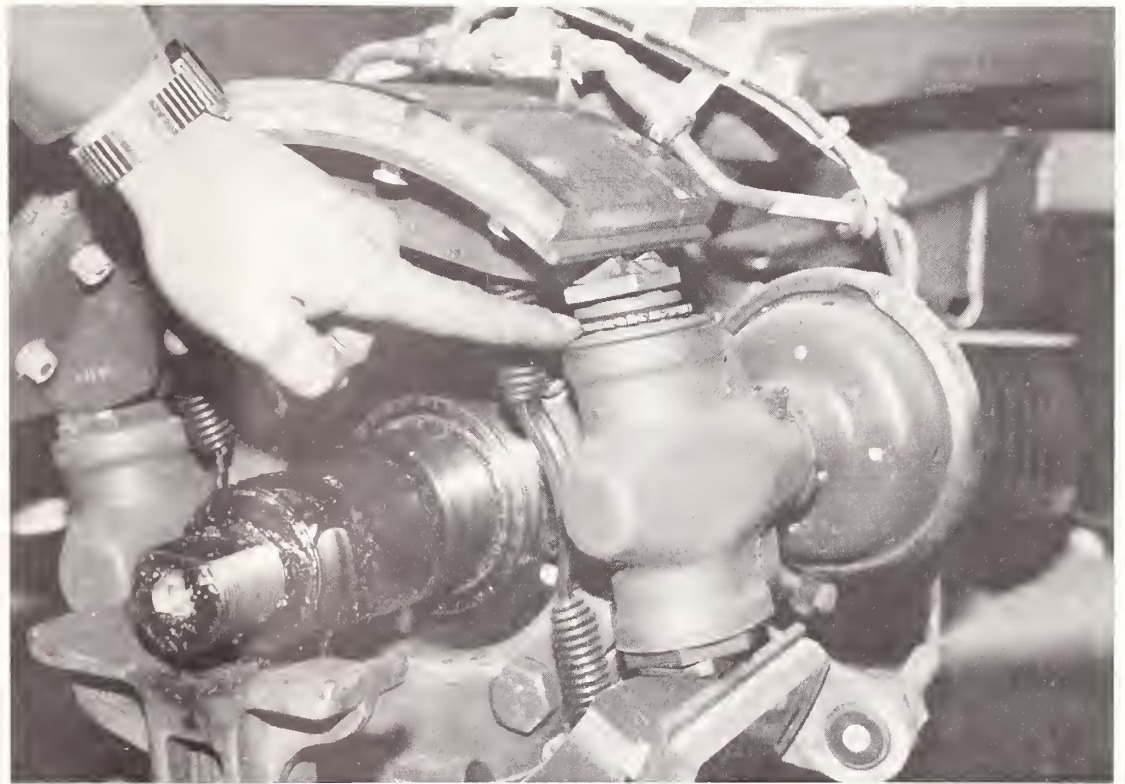

***Part of the Technology Sharing program is aimed at communicating near-term solutions to technical problems encountered by our mass transit systems.***

directory. The communication mediums employed—overviews, digests, factsheets and other documents—serve to condense and translate technical information on both locally developed and UMTA sponsored innovations into forms appropriate to technical and nontechnical audiences alike. This project also provides for direct dissemination of several types of informal and interim technical reports among transit agencies and state and local governments.

A second program (DC-06-0382) provides condensed results of innovative projects in newsletter format. Publications

include Transit Technology Briefs, Transit Actions (management innovations), SMD Briefs (service and methods innovations) and Planning Briefs. These are designed to convey technical news and provide essential information for follow-up. They are not periodical publications but are prepared as need and opportunity arise. For information on how to obtain copies, call or write to:

Public Technology, Inc.  
1301 Pennsylvania Avenue, N.W.  
Washington, DC 20004  
(202) 626-2465



Under another project (DC-06-0287) the International City Managers Association is developing a technical package to increase city manager awareness of key transit issues and provide them with the technical information needed to make effective transit-related decisions.

## Information Services

| PROJECT TITLE  | NUMBER     | FUNDING              | SCHEDULE                 | AGENCY/<br>CONTRACTOR                   | TECHNICAL<br>CONTACT            |
|--|------------|----------------------|--------------------------|---|---------------------------------|
| <b>SECTION 15 INFORMATION</b>  |            |                      |                          |   |                                 |
| Provide Technical Support for Administration of Section 15                       | DC-06-0383 | \$883,000            | Sept. 1981-<br>Oct. 1984 | Washington Consulting Group             | Rhoda Shorter<br>(202) 426-9157 |
| Evaluate Section 15 Data Base and Generate Output Records                        | MA-06-0107 | \$2,136,000          | Sept. 1979-<br>Ongoing   | TSC                                     | Rhoda Shorter<br>(202) 426-9157 |
| Develop Performance Measures for Statewide Evaluation of Transit Service         | MA-06-0018 | \$150,000            | Oct. 1980-<br>Oct. 1982  | Commonwealth of Massachusetts           | A. B. Hallman<br>(202) 426-9274 |
| <b>TECHNICAL INFORMATION SERVICES</b>  |            |                      |                          |   |                                 |
| Develop and Maintain UMRIS   | DC-06-0285 | \$913,025            | Oct. 1981-<br>Oct. 1984  | TRB                                     | Helen Tann<br>(202) 426-9157    |
| Technical Sharing Support  | MA-06-0086 | \$310,000<br>(FY 82) | Continuing<br>Multi-year | TSC                                     | Phil Hughes<br>(202) 426-9157   |
| Technical Assistance Briefs  | DC-06-0382 | \$100,000            | Oct. 1980-<br>Sept. 1982 | Public Technology, Inc.                 | Helen Tann<br>(202) 426-9157    |
| Provide Technical Information and Managerial Training Materials to City Managers | DC-06-0287 | \$460,000            | Dec. 1980-<br>Dec. 1982  | International City Managers Association | Alice Royal<br>(202) 426-0080   |

### Bibliography

A list of recent reports follows. Please consult previous editions of this Directory for earlier reports. If available, a document number assigned by the National Technical Information Service (NTIS) is listed. Reports may be obtained from NTIS by using the order blanks provided at the end of this document.

Reports which have not been assigned an NTIS number may not have been published in sufficient quantity for general distribution. Single copies and other information may be available from the issuing agency or organization.

Additional reports relating to the research described in this chapter may become available in the near future. For the most recent information or suggestions

for additional reference materials regarding specific projects, call or write to the person listed as the technical contact in the Project Summary Table.

### SECTION 15 INFORMATION

**National Urban Mass Transportation Statistics, First Annual Report: Section 15 Reporting System**  
Proj. MA-06-0107

Transportation Systems Center  
May 1981, GPO-050-014-00021-5

**National Urban Mass Transportation  
Statistics, Second Annual Report:  
Section 15 Reporting System**

Proj. MA-06-0107  
Transportation Systems Center  
June 1982

**National Urban Mass Transportation  
Statistics, 1981:**

**Section 15 Report**  
Proj. MA-06-0107  
Transportation Systems Center  
November 1982

**TECHNICAL INFORMATION SERVICES**

**A Directory of Regularly Scheduled, Fixed  
Route, Local Rural Public Transportation  
Service**

UMTA Technical Notice 1-81  
Office of Transportation Management  
February 1981

**A Directory of Regularly Scheduled, Fixed  
Route, Local Public Transportation Service  
in Urbanized Areas Over 50,000 Population**

UMTA Technical Notice 2-81  
Office of Transportation Management  
August 1981

**Urban Mass Transportation Abstracts:  
January - February 1982**

**March - April 1982**

**May - June 1982\***

**July - August 1982**

**September - October 1982**

**November - December 1982\***

Office of Technical Assistance, Information  
Service

(\* Includes semi-annual Keyword Index)

**Urban Mass Transportation Cumulative  
Bibliography, 1974-1980**

**Vol. I, Abstracts**

**Vol. II, Index**

Proj. DC-06-0258  
Transportation Research Board  
April 1982

**Urban Transportation Abstracts, Summer  
1982**

**Vol. I, No. 1**

Proj. DC-06-0258-82-3  
Transportation Research Board  
August 1982

**Innovation in Public Transportation  
Fiscal Year 1979: A Directory of Research,  
Development and Demonstration Projects**

Proj. MA-06-0086  
Transportation Systems Center  
1980

**Innovation in Public Transportation  
Fiscal Year 1980: A Directory of Research,  
Development and Demonstration Projects**

Proj. MA-06-0086  
Transportation Systems Center  
1981

**Innovation in Public Transportation  
Fiscal Year 1981: A Directory of Technical  
Assistance Programs**

Proj. MA-06-0086  
Transportation Systems Center  
1982



# National Cooperative Transit Research and Development Program

---

## Trends and Highlights

The National Cooperative Transit Research and Development Program (NCTRP), which was initiated in FY 79, was developed to provide UMTA's primary constituents—the transit industry, cities, counties and states—an opportunity to participate collectively in identifying and resolving near-term transit research and development problems. The program is conducted cooperatively by the Transportation Research Board (TRB) of the National Academy of Sciences, the American Public Transit Association (APTA), the Urban Consortium for Tech-



nology Initiatives/Public Technology, Inc., and UMTA.

Each year, beginning in January, the NCTRP solicits new research ideas from the transit industry. A technical steering group then reviews industry-recommended ideas, identifies priority topics and establishes an annual agenda of research. The TRB serves as coordinator for NCTRP by defining specific research projects and subcontracting for work to be performed by organizations with expertise in the particular topics.

An important practical objective of NCTRP is to establish a closer working relationship between government agencies and transit operators and suppliers in order to expedite UMTA's efforts to make research results available to the users. UMTA budget proposals allocate approximately \$1 million annually for this program.

In the first three years of this program more than 250 research ideas have been submitted by industry. As of this reporting period, 28 projects have been selected for the NCTRP, and 14 research contracts have been awarded. During FY 1982, four projects dealing with near-term bus operation problems have been completed, and reports from these projects have been widely distributed to the industry.

## Research Topics and Proposals

NCTRP topic selection begins with the receipt of good ideas about near-term research needs in transit, submitted voluntarily by individuals and organizations with an interest in public transportation. Requiring only a brief problem statement

by the initiator, the NCTRP offers an independent channel for acting on research needs that are not funded under other ongoing UMTA activities. For more information on submitting topics of NCTRP, contact Mr. Frank Cihak, APTA, (202) 828-2800.

The NCTRP also offers qualified individuals and organizations a chance to conduct research on topics that have been previously approved by the technical steering group. For more information on submitting research proposals to NCTRP, contact Mr. Kreiger Henderson, TRB, (202) 344-3227.

Additional projects are added to the program each year; those selected during FY 82 are given in the table at the end of this section. Specific work statements supporting these topics are now in preparation, and most of the work will be subcontracted by TRB during FY 83.

## Active NCTRP Projects

The projects described in this section represent the active NCTRP program. Final reports for projects completed during FY 82 appear in the bibliography at the end of the chapter. In the following paragraphs, each of the active NCTRP projects is related to an important issue facing the industry. The discussion illustrates the breadth of disciplines necessary to address priority problems of the industry.

One of the important decisions facing both rural and urban transit decision-makers is whether to invest scarce funds in more expensive or less expensive small transit buses. The complexity of needs and possible solutions has led to many poor choices of buses for specific duties.

No guidelines exist to help transit providers seeking to purchase or replace small buses to make objective decisions concerning the best bus type to be procured. In response to this problem, a project (30-1) has been planned which will develop a workbook-style manual for local transit operators and will identify key recommendations that could feasibly be taken up by transit operators, local governments, states and UMTA to substantially improve procurement, operation and maintenance processes for small transit buses.

The costs and effects of grant requirements are causing increasing concern to transit agencies. A Section 3 grant application for a new bus purchase requires approximately 21 exhibits to comply with UMTA regulations. An NCTRP project is underway to determine the costs and effects of federal legislation, regulations, UMTA circulars, administrative letters and formal administrative guidelines for the Section 3 capital grant application process, and to make recommendations for its improvement. The study results are anticipated to be useful to 1) transit agencies in making the decision to apply for federal grants, 2) legislators in drafting legislation and 3) the Urban Mass Transportation Administration in amending requirements.

Some bus operators possessing the basic skills necessary for vehicle operation may still be unable to perform their job satisfactorily because of an inability to cope effectively with the public. No amount of training and disciplinary action is of use when the individual hired lacks the psychological strengths necessary to deal effectively with continuous public contact. The resulting stress may lead to

## Projects Approved In FY 1982

| TITLE   | NCTRP<br>PROBLEM<br>NUMBER | ESTIMATED<br>FUNDING | UMTA<br>LIAISON                  |
|---|----------------------------|----------------------|----------------------------------|
| Assessment of Job Enrichment Programs for the Transit Industry (Continuation)                   | 33-2                       | \$ 50,000            | Chuck Morison<br>(202) 426-0080  |
| National Transit Computer Software Directory (Continuation)                                     | 38-1                       | 50,000               | Tom Hillegass<br>(202) 426-9271  |
| Fare Collection Problems and Solutions  | T82-4/31/40                | 75,000               | Paul Spencer<br>(202) 426-0090   |
| Transportation and Maintenance Manpower Planning  | T82-26/32                  | 100,000              | Chuck Morison<br>(202) 426-0080  |
| Development of Formulas to Determine the Marginal Cost of Various Transit Services              | T82-11/17                  | 150,000              | Brian McCollum<br>(202) 426-9271 |
| Development of an Automated Dispatching Systems   | T82-6                      | 40,000               | Tom Hillegass<br>(202) 426-9271  |
| Development of a Methodology to Calculate Financial Benefits Induced by Fixed Rail Mass Transit | T82-30/36                  | 100,000              | Ed Thomas<br>(202) 426-9267      |
| Conversion to One-Man Operation of Older Rapid Transit Systems                                  | T82-37                     | 150,000              | Jeff Mora<br>(202) 426-0090      |
| Single Cable Communications Technology for Underground Rapid Transit Systems                    | T82-12                     | 150,000              | Fred Sing<br>(202) 426-0090      |
| Develop a Manual of Transit Signing at Bus Stops (Synthesis)                                    | T82-45                     | 45,000               | Burt Arrillaga<br>(202) 426-4984 |
| Bus Communications Systems (Synthesis)  | T82-39                     | 45,000               | Denis Symes<br>(202) 426-8483    |
| Passenger Information Systems for Transit Transfer Facilities (Synthesis)                       | T82-44                     | 45,000               | Burt Arrillaga<br>(202) 426-4984 |



more workers' compensation claims as well as to more accidents, absenteeism, and personnel turnover. A project (33-1) has been initiated to develop an evaluative device or questionnaire for use as part of the bus driver selection process. This device would be a valid indicator of the applicant's susceptibility to stresses likely to affect job performance. Another human resources development project (33-2), defined in FY 81, will assess the applicability of job enrichment programs throughout a transit agency's organization.

Management tools which can be used to plan and evaluate transit systems continue to be the focus of the research needs expressed by transit managers. One project already underway (36-1) responds to the need for an evaluation of UMTA's "Alternatives Analysis" process and will provide recommendations for improvements to promote more effective local, state and federal decisions regarding major capital investments. The project will examine actual experience and assess the degree to which analytical requirements have provided appropriate information at key decision points.

Three other projects underway are also directed at the problems faced by local managers. The National Transit Computer Software Directory Project (38-1) will develop and pilot test an automated system for maintaining up-to-date information on software suitable for use by transit agencies of all sizes. To assist in improving route productivity, an assessment of passenger counters, farebox recorders, location detecting devices and other automated data collection systems will be undertaken. The ultimate objective of this study (39-1) is to define a set of modules that will allow transit managers



*One recently completed NCTRP study dealt with transit bus washing equipment and procedures.*

to choose the level and type of hardware needed for the data required. Another project (40-1) will develop guidelines which can be used by nontechnical people to develop and present cost benefit and alternatives analysis data for smaller cities. This research will address the need for a technically based but simple analytical tool for use in the public decision-making process. Most available methods are too data-intensive for easily comprehensible public presentation or for use in small cities.

Rail transit operators have expressed the need for a means of detecting power

leakages which reduce the safety and performance of their systems. Electrical faults that are not indicated by the circuit breakers are particularly difficult because the characteristics of a fault current resemble those of train and power switching operations. A project (43-1) is being undertaken to seek a practical solution to this problem.

Although bus transit operators are evaluating bonded brake linings and other commercially available means to extend brake life, significant improvements may depend on a more fundamental look at the problem. An NCTRP project (47-1) is ex-

aming brake operating temperatures, identifying heat dissipation techniques, and reviewing alternative friction materials. The brake wear problem is costly as well as universal with heavier modern buses.

Increased energy costs are also having a major effect on rail transit systems. An NCTRP project (54-2) is underway to develop methods for forecasting, monitoring and controlling peak electric energy demand. The peak demand component of electricity rates is directly related to facility costs, and transit operators are subject to allocated costs associated with those facilities. The objective of this research is to evaluate load management techniques and other efficiency measures, and to assess their effectiveness in reducing peak demand and energy costs.

Three of the five reports completed during FY 82 were from a continuing activity (60-1) under which the NCTRP produces short-term syntheses of information on transit problems selected by the technical steering group. The objective of this effort is to make existing (but undocumented or fragmented) knowledge more readily available to the industry. These synthesis reports, widely distributed during the past year, included summary information on bus cleaning procedures (TS-1) and enforcement of bus priority techniques (TS-2). A digest of information on bus operator stress was also completed as a companion to NCTRP project 33-1.

Two other major research reports were completed and distributed during FY 82. In response to a general lack of information on fuel consumption data for use in making procurement decisions, NCTRP completed a project (54-1) on transit bus



***An NCTRP project on transit bus fuel economy has resulted in a recommended approach for making tradeoffs between fuel economy and performance as part of bus procurement decisions.***

energy efficiency and productivity. The report provides a set of guidelines for use by transit managers in selecting and specifying buses. The guidelines address the interrelation of components (e.g., axle ratio vs. engine rating vs. transmission shift points) and the tradeoffs between energy efficiency and performance, as well as the energy costs of such additional features

as air conditioning, wheelchair lifts and kneeling capacity.

The second major report (31-1) concerned the impacts of federal grant requirements on transit agencies. This report provides information to local agencies on the timing and impact of federal grant requirements, and attempts to show how certain adverse impacts may be alleviated.



## National Cooperative Transit Research and Development Program (NCTRP)

| PROJECT TITLE   | NUMBER   | FUNDING                                  | SCHEDULE              | RESEARCH AGENCY                                | TECHNICAL CONTACT                    |
|---|--|--|-----------------------|--|--------------------------------------|
| NCTRP Program Management and Evaluation                                     | MD-06-0053<br>DC-06-0230<br>DC-06-0231<br>DC-06-0232 | \$1,000,000<br>(Total annual allocation) | March 1979-Continuing | TRB; APTA; Public Technology, Inc.; Onyx Corp. | John Durham<br>(202) 426-9267        |
| Small Transit Buses: A Manual for Improved Purchasing, Use, and Maintenance | NCTRP 30-1   | \$300,000                                | To Be Determined      | To Be Selected                                 | R. Ian Kingham<br>(202) 334-3224     |
| Impacts of Federal Grant Requirements on Transit Agencies                   | NCTRP 31-1   | \$50,000                                 | Dec. 1981-Aug. 1982   | Booz, Allen and Hamilton, Inc.                 | R. Ian Kingham<br>(202) 334-3224     |
| Transit Bus Operator Selection and Training for Dealing with Stress         | NCTRP 33-1   | \$150,000                                | Oct. 1981-Oct. 1983   | Group Associated Mgmt. Services, Inc.          | Robert E. Spicher<br>(202) 334-3224  |
| Assessment of Job Enrichment Programs for the Transit Industry              | NCTRP 33-2   | \$100,000                                | To Be Determined      | To Be Selected                                 | Crawford F. Jencks<br>(202) 334-3224 |
| Improving Decision-Making for Major Urban Transit Investments               | NCTRP 36-1   | \$150,000                                | Nov. 1981-Feb. 1983   | System Design Concepts, Inc.                   | R. Ian Kingham<br>(202) 334-3224     |
| National Transit Computer Software Directory                                | NCTRP 38-1   | \$100,000                                | To Be Determined      | To Be Selected                                 | Harry A. Smith<br>(202) 334-3224     |
| A Modular Approach to On-Board, Automatic Data Collection Systems           | NCTRP 39-1   | \$150,000                                | To Be Determined      | To Be Selected                                 | Crawford Jencks<br>(202) 334-3224    |
| Simplified Guidelines for Evaluating Transit Options in Small Urban Areas   | NCTRP 40-1   | \$150,000                                | To Be Determined      | To Be Selected                                 | Robert E. Spicher<br>(202) 334-3224  |
| Detection of Low-Level Fault Currents on Rail Transit Systems               | NCTRP 43-1   | \$100,000                                | To Be Determined      | To Be Selected                                 | Harry A. Smith<br>(202) 334-3224     |



## National Cooperative Transit Research and Development Program (NCTRP)

| PROJECT TITLE  | NUMBER     | FUNDING   | SCHEDULE                 | RESEARCH AGENCY                | TECHNICAL CONTACT                   |
|--|------------|-----------|--------------------------|--------------------------------|-------------------------------------|
| Improved Service Life of Urban Transit Coach Brakes    | NCTRP 47-1 | \$300,000 | Dec. 1981-<br>Nov. 1983  | Battelle Memorial Institute    | Harry A. Smith<br>(202) 334-3224    |
| Energy Management of Electric Rail Transit Systems     | NCTRP 54-2 | \$135,115 | Oct. 1981-<br>Dec. 1982  | Carnegie-Mellon University     | Harry A. Smith<br>(202) 334-3224    |
| Synthesis of Information Related to Transit Problems   | NCTRP 60-1 | \$210,000 | Nov. 1980-<br>Continuing | Transportation Research Board  | Robert J. Reilly<br>(202) 334-3224  |
| Improve Transit Bus Energy Efficiency and Productivity | NCTRP 54-1 | \$39,976  | Oct. 1981-<br>April 1982 | Booz, Allen and Hamilton, Inc. | Robert E. Spicher<br>(202) 334-3224 |

### Bibliography

A list of reports prepared during FY 82 follows. NCTRP reports are available from the Transportation Research Board, National Academy of Sciences, 2101 Constitution Avenue, N.W., Washington, D.C. 20418.

#### **Cleaning Transit Buses: Equipment and Procedures**

Proj. TS-1  
ATE Management and Service Co., Inc.  
March 1982, Synthesis I, price \$6.80

#### **Enforcement of Priority Treatment for Buses on Urban Streets**

Proj. TS-2  
PAWA, Inc.  
May 1982, Synthesis 2, price \$6.40

#### **Review of Literature Related to Bus Operator Stress**

Proj. 33-1  
Robert E. Spicher  
June 1982, Digest 1

#### **Transit Bus Energy Efficiency and Productivity: Bus Equipment Selection Handbook**

Proj. 54-1  
Booz, Allen and Hamilton, Inc.  
July 1982, Report 1, price \$7.20

#### **Impacts of Federal Grant Requirements on Transit Agencies**

Proj. 31-1  
Booz, Allen and Hamilton, Inc.  
January 1983, Report 2, price \$7.60

# Safety And Security

## Trends and Highlights



The UMTA transit safety and security program consists of three major elements: 1) system safety and security, 2) information collection and processing, and 3) generic research. All three of these elements are interdependent. The program emphasizes voluntary initiatives on the part of transit systems in implementing safety, security and related system assurance programs. UMTA monitors these programs with the support of other organizations such as the Transportation Systems Center (TSC), the American Public Transit Association (APTA) and the Transportation Safety Institute (TSI). The Safety and Security Staff is now expanding its role of technical assistance and research, especially in the realm of transit security. An anti-crime demonstration in Dade County, Fla., was initiated this year. One highlight of the year was a workshop in fire/life safety that brought together rail transit representatives and fire officials to identify the training requirements needed to improve their capability in responding to fires and other life threatening emergencies in rail transit systems.

## System Safety and Security

System safety and security, the most significant element of the UMTA rail transit safety program, involves developing and conducting programs and activities focused on the elimination or control of hazards and the prevention of accidents. These programs and activities can be applied throughout the life of a transit system so that it can systematically achieve the highest practical levels of safety with-

out depending only upon information gained after accidents.

UMTA is helping rail and bus transit agencies to develop system safety program plans. These plans provide transit authorities with a way to document their safety program and display their commitment to safety. They also provide a means of conducting audits, reviews and evaluations of the property's safety program.

UMTA participated in a safety peer review for the Southern California Rapid Transit District (SCRTD) rail transit development in Los Angeles, Calif. A peer review board, including representatives from four transit authorities, provided knowledge, expertise and experience to SCRTD in safety and system assurance matters during the preliminary engineering phase of the system. Peer review topics were design and operational safety requirements, safety programs, and safety analysis methodology.

An unsafe condition investigation was carried out by UMTA at the New York City Transit Authority (NYCTA) in FY 81, with the support of FRA, TSC and TSI. NYCTA experienced safety problems with the trucks, handbrakes and DC power cables on its R-46 cars. UMTA continues to monitor truck replacement along with the other safety problems of the R-46 cars.

System safety and security education and training for the transit community is another program activity. Since 1976, UMTA has funded the development and presentation of several safety, security and system assurance courses held at TSI in Oklahoma City. These courses were identified, developed and conducted through the cooperative efforts of UMTA, TSI, APTA and representatives from the transit industry. During the past year,

courses on mass transit security, bus accident investigation and system safety, rail accident investigation and system safety analysis, were held at TSI. Seminars on explosives management and bus accident investigation were presented in various cities.

UMTA also responds to inquiries about safety from the public, local officials and the Congress. Among the subjects of inquiries received in FY 82 were rail vehicle undercar fires in the motor-control group and traction motors, and on-board falls from transit vehicles. Each of the inquiries was acted upon to insure that

legitimate safety problems were properly resolved by the transit agency in question.

Program support for UMTA system safety activities is provided under continuing reimbursable agreements with two DOT offices. One of these agreements is with TSI at Oklahoma City (DC-06-0215) under which TSI provides personnel and facilities support to UMTA for system safety and security education and training. The other agreement is with TSC in Cambridge, Mass. (MA-06-0060), which provided support to UMTA for the workshop in fire/life safety and a safety peer review in Los Angeles in FY 82.



**Over 1400 transit managers received safety and security training in FY 82 at sessions such as this bus accident investigation workshop.**



Technical support to the UMTA system safety activities was provided under an APTA contract, through which APTA gathered information and provided technical expertise on transit safety issues (DC-06-0366). Additional program support for UMTA is being provided by a reimbursable agreement with the Federal Emergency Management Agency (FEMA), U.S. Fire Academy (DC-06-0367). FEMA is providing fire safety expertise to UMTA and is assisting in developing fire emergency and life safety training for rapid rail transit personnel. A part of the FEMA agreement is to conduct fire/life safety workshops to determine transit and fire service training needs. A planning workshop on fire and life safety in rapid rail transit was held on August 2-4, 1982.

A project initiated in FY 82 with the Metropolitan Dade County (Fla.) Transit Authority (FL-06-0025) entails the use of undercover police officers on the bus system. The overall objective of this anti-crime demonstration is to develop a transit security program in order to reduce transit crime, increase rider perception of security and develop procedures for policing the Dade County transit system.

## Safety Information

Part of UMTA's responsibility for the safety of both rapid and light rail transit systems is to develop a new rapid rail transit accident/incident reporting system, under the title Safety Information Reporting and Analysis System (SIRAS). The rapid rail transit systems continued to report into the existing FRA system (DC-06-0390) until February 1, 1982. Annual reports have been published for the data



***NORTTRAN, in Des Plaines, Illinois, obtained reduced worker's compensation insurance rates as a result of preventive programs derived from safety training at the Transportation Safety Institute.***

gathered for the years 1978-1981. The 1982 data is in the process of being published. The office also conducted a workshop in FY 82 with representatives of the rail transit industry for review and comment on the final development of SIRAS. Reporting forms, procedures, and dollar thresholds necessary for transit authorities to report information related to accidents/incidents were developed. SIRAS will become operational on February 1, 1983, with rapid rail systems reporting their accident/incident data to UMTA. Program support for SIRAS is provided under an agreement with TSC (MA-06-0080).

UMTA currently has no mechanism for collecting and analyzing safety data on transit bus operations. Furthermore, no national data base of transit bus accidents/injuries suitable to meet UMTA safety information needs exists. Accident and casualty information is gathered by various sources (local jurisdictions, state police, National Highway Traffic Safety Administration and others), but not in a uniform manner. Definitions of accidents and casualties differ among the various information collection sources. A feasibility study is planned to determine the state of transit bus safety, evaluate current sys-



***One way of preventing transit accidents is by obtaining information on where and when accidents occur. SIRAS will accomplish this by collecting and analyzing data for all urban rail systems.***

tems for collecting data on transit bus accidents and injuries, and assess the feasibility of an UMTA transit bus reporting system.

## Safety Research

The UMTA safety research program is directed toward significant and critical safety problems which are generic rather than site-specific. At present, the project with the highest priority for UMTA and the

industry is the development of preparedness guidelines for rail transit emergencies. TSC is preparing a comprehensive document of emergency preparedness guidelines produced through a cooperative effort by UMTA and the transit industry. These guidelines incorporate the emergency preparedness aspects of the APTA Design Guidelines, APTA preliminary emergency preparedness guidelines, NFPA 130, and other research such as the UMTA/FEMA fire and life safety effort and the Automated Sciences Group (IT-06-0267) guidelines.

As part of the continuing fire safety practices effort with TSC to reduce the threat of transit system fires (MA-06-0060), fire safety countermeasures recommendations were developed for rail transit materials selection, and published in the Federal Register. An assessment of the Bay Area Rapid Transit District (BART) vehicle fire-hardening program was initiated in FY 82. This technical assistance effort by TSC for UMTA responds to ten concerns in the BART fire safety improvement program conducted by the California Public Utilities Commission. Work on plans and procedures for emergency evacuation of elderly and handicapped people, and research on transit passenger slips and falls are continuing. A corrosion control manual was completed and will be published early in FY 83. A study on extreme environmental conditions that affect rapid transit systems, including an examination of their impact on rail system safety, is underway.



***Recommendations for the selection of rail transit vehicle interior materials were recently published in the Federal Register.***





*Simulated evacuation drills, recommended in the Emergency Preparedness Guidelines, are designed to help transit systems evaluate and improve their performance in the face of real emergencies.*



## Safety and Security

| PROJECT TITLE   | NUMBER     | FUNDING     | SCHEDULE                  | AGENCY/<br>CONTRACTOR                     | TECHNICAL<br>CONTACT                  |
|---|------------|-------------|---------------------------|---|---------------------------------------|
| <b>SYSTEM SAFETY AND SECURITY</b>                                   |            |             |                           |   |                                       |
| Program Support   | DC-06-0215 | \$1,159,502 | Nov. 1977-<br>Continuing  | TSI                                       | Gwendolyn R. Cooper<br>(202) 426-2896 |
|   | MA-06-0060 | \$720,000   | Sept. 1978-<br>Continuing | TSC                                       | Lloyd G. Murphy<br>(202) 426-2896     |
| Technical Support   | DC-06-0366 | \$300,000   | Jan. 1982-<br>Continuing  | APTA                                      | Roy Field<br>(202) 426-2896           |
| Fire Safety Support   | DC-06-0367 | \$159,000   | Sept. 1981-<br>Feb. 1982  | Federal<br>Emergency<br>Management Agency | Gwendolyn R. Cooper<br>(202) 426-2896 |
| Metropolitan Dade<br>County Anti-Crime<br>Demonstration             | FL-06-0025 | \$450,000   | Feb. 1982-<br>Continuing  | Dade County,<br>Fla.                      | Gwendolyn R. Cooper<br>(202) 426-2896 |
| <b>SAFETY INFORMATION</b>   |            |             |                           |   |                                       |
| Information Processing  | DC-06-0390 | \$30,000    | Oct. 1980-<br>Sept. 1982  | FRA                                       | Lloyd G. Murphy<br>(202) 426-2896     |
| Rail Transit Safety<br>Information Reporting<br>and Analysis System | MA-06-0060 | \$1,360,000 | Sept. 1978-<br>Continuing | TSC                                       | Lloyd G. Murphy<br>(202) 426-2896     |
| <b>SAFETY RESEARCH</b>  |            |             |                           |   |                                       |
| Emergency Preparedness  | IT-06-0267 | \$210,000   | July 1981-<br>April 1982  | Automated Sciences<br>Group               | Roy Field<br>(202) 426-2896           |
| Rail Safety R&D   | MA-06-0060 | \$1,069,000 | Nov. 1978-<br>Continuing  | TSC                                       | Roy Field<br>(202) 426-2896           |
| Extreme Conditions<br>Impact on Rapid<br>Transit Systems            | VA-06-0086 | \$99,949    | Sept. 1981-<br>Dec. 1982  | Technology Research<br>and Analysis Corp. | Abdo S. Ahmed<br>(202) 426-2896       |

## **Bibliography**

A list of recent reports follows. Please consult previous editions of this Directory for earlier reports. If available, a document number assigned by the National Technical Information Service (NTIS) is listed. Reports may be obtained from NTIS by using the order blanks provided at the end of this document.

Reports which have not been assigned an NTIS number may not have been published in sufficient quantity for general distribution. Single copies and other information may be available from the issuing agency or organization.

Additional reports relating to the research described in this chapter may become available in the near future. For the most recent information or suggestions for additional reference materials regarding specific projects, call or write to the person listed as the technical contact in the Project Summary Table.

### **Identification of the Fire Threat in Urban Transit Vehicles**

Proj. MA-06-0051  
Transportation Systems Center  
June 1980, PB 80-217-631

### **Identification and Evaluation of Operational Alternatives for Materials Data Bank**

Proj. MA-06-0051  
Transportation Systems Center  
July 1980, PB 80-217-631

### **Rail Transit Safety Annual Report, 1980**

Proj. MA-06-0098  
Transportation Systems Center  
September 1981, PB 82-142-530

### **Annotated Bibliography of Rail Transit Safety, 1975-1980, with Emphasis on Safety Research and Development**

Proj. MA-06-0098  
Transportation Systems Center  
September 1981, DOT-TSC-UMTA-81-56

### **Rail Transit Safety Annual Report, 1981**

Proj. MA-06-0060  
Transportation Systems Center  
October 1982, PB 83-145-110

### **Assessment of BART Fire-Hardening Programs**

Proj. MA-06-0060  
Transportation Systems Center  
November 1982, UMTA-MA-06-0060-82-3

# Policy and Program Development

## Trends and Highlights



UMTA's policy and program development activities provide information for the planning, coordination and evaluation of UMTA programs, as well as development of its budget. The program also includes policy analysis used in the formulation of national transportation legislation and major DOT and UMTA policies, regulations and directives.

The basic goal of this research is to promote the most efficient and effective use of federal resources supporting private and public sector provision of passenger transportation. To this end, UMTA conducts and monitors research on the transit industry's economic and financial condition, and on its existing and projected needs.

Current policy and program initiatives include work on program investment policies, procedural policies, private enterprise policy and paratransit policy. Also underway are a review of UMTA's capital and research investment plan, an impact assessment of the phase-out of federal operating subsidies, the development of guidelines for administering the labor standards provisions, Section 13(c), of the Urban Mass Transportation Act of 1964, a review of state and local dedicated revenue sources, examination of innovative financing techniques, and refinement of the decision-making process for policy-related issues.

## Policy Development

In 1982, policy development efforts concentrated on policies for implementing recent national priorities. New policies were established in such areas as investment strategy, rail modernization, major



investments, construction starts, people movers and maintenance. Work was also undertaken to provide opportunities for greater private sector involvement in mass transit. A major review of all UMTA regulations was conducted.

Interest in paratransit issues continued. A study of taxicab operating characteristics (MD-06-0080) looked at the current state of the taxi industry to assess its economic health and identify problems arising from increased operating costs. Another study (CA-06-0153) examined the role of taxis in providing transportation for the elderly and handicapped. Although this study focused primarily on services in California, taxi-based specialized transit in other areas was also considered.

The Technical Assistance for Small Taxi Operators project (NC-06-0005) was designed to help small taxi operators in North Carolina understand the complexities of the federal transportation program, thereby enabling them to obtain federal assistance and to participate in the local transportation planning process. Another project (IT-06-0249) provided an analysis of labor protection agreements and U.S. Department of Labor determinations among paratransit operators. The effect of labor protection issues on labor/management relations was examined in terms of the ability of the transit and taxi industries to provide paratransit service.

Another project (DC-06-0429) examined the recent trend among state and local governments to secure sources of stable funding, and describes those sources which have received the greatest amount of attention.

In a project entitled Obstacles to Private Enterprise Participation in Public Programs (TN-06-0011), background material

was assembled for a DOT Private Enterprise Regulation currently being developed. The contractor in this project examined private operator perceptions of the barriers to private involvement in the local transportation planning process, as well as of the difficulties entailed in the delivery of services contracted with public agencies.

## Policy Research

Studies and analysis projects in policy research provide data and ideas for the formulation of long-term goals and objectives for UMTA programs. Major research efforts in FY 82 were directed at such areas as urban revitalization, joint transit/land use development, paratransit, light rail and urban rail transit, parking management and transit financing.

Two studies of paratransit were completed. The first, an analysis of progress being made by foreign countries in the field of paratransit (FN-06-0004), will enable the United States to benefit from foreign experience. The second study (DC-06-0150) evaluated the potential of paratransit on the basis of experience to date, and should be of use in determining its role in improving mobility.

UMTA, in conjunction with the Federal Highway Administration and the Brookings Institute, continued cooperative funding for a study of the future of large American cities (DC-06-0221). This study analyzed the combined influence of several important variables—including housing, transportation and economic health—and predicts their impact on the future of major urban areas.

Two projects studying methods for improving performance and lowering costs in light rail transit (LRT) were com-

pleted. One of these (IT-06-0103-03) investigated the feasibility of and procedures for standardizing LRT-system components. Standardization of power distribution subsystems, signals and controls, at-grade intersections, switches, stations and other elements would mean that they could be mass produced, would cost less, be more reliable and require less maintenance. The other LRT project (IT-06-0103-02) examined such cost and service improvements as a self-service fare collection system that could reduce trip time and personnel requirements while permitting more equitable fare structures; preemptive intersection signals; protective barriers for pedestrians; pedestrian malls, and various methods for facilitating vehicle flow.

A study of parking management strategies was also completed (DC-06-0225). This study provides a state-of-the-art overview of the most significant parking practices currently in use across the country, evaluating their success, prevalence and potential for aiding in management and decision-making.

A joint FHWA/UMTA project is setting up a center for Urban Mobility Research to facilitate the combined efforts of federal, state and private entities to identify and assess various techniques for encouraging public/private provision and financing of urban public transportation services (TX-06-0041).

In 1982, UMTA staff studied nine states to observe the development of state assistance programs for public transportation (MA-06-0109). The results of this study are being used to examine trends in state support of transit, and to ascertain the implications for future federal assistance programs.

## Policy and Program Development

| PROJECT TITLE   | NUMBER        | FUNDING   | SCHEDULE                  | AGENCY/<br>CONTRACTOR                           | TECHNICAL<br>CONTACT                |
|---|---------------|-----------|---------------------------|---|-------------------------------------|
| <b>POLICY DEVELOPMENT</b>   |               |           |                           |   |                                     |
| Taxicab Operating Characteristics   | MD-06-0080    | \$99,500  | Sept. 1980-<br>Dec. 1981  | International<br>Taxicab Association            | Douglas M. Birnie<br>(202) 426-4058 |
| Issues in Taxi-based Specialized Transit Service                                      | CA-06-0153    | \$50,000  | Sept. 1980-<br>Jan. 1982  | University of<br>California at Irvine           | Douglas M. Birnie<br>(202) 426-4058 |
| Technical Assistance for Small Taxi Operators   | NC-06-0005    | \$28,200  | Oct. 1980-<br>April 1983  | University of<br>North Carolina                 | Douglas M. Birnie<br>(202) 426-4058 |
| Analysis of Paratransit Labor Protective Arrangements                                 | IT-06-0249    | \$48,500  | Nov. 1979-<br>Feb. 1981   | ATE Manage-<br>ment and Service Co.             | Douglas M. Birnie<br>(202) 426-4058 |
| Recent Efforts to Enact Dedicated Revenue Sources                                     | DC-06-0429    | \$8,300   | April 1982-<br>Sept. 1982 | Jeffrey A. Parker                               | Robert Martin<br>(202) 426-4060     |
| Obstacles to Private Enterprise Participation   | TN-06-0011    | \$62,300  | Aug. 1980-<br>July 1983   | Ground Airport<br>Transportation<br>Association | Douglas M. Birnie<br>(202) 426-4058 |
| <b>POLICY RESEARCH</b>  |               |           |                           |   |                                     |
| Analysis of Paratransit in Europe   | FN-06-0004    | \$70,000  | July 1978-<br>Jan. 1981   | Ecoplan<br>International                        | James S. K. Yu<br>(202) 426-4060    |
| Paratransit Assessment  | DC-06-0150    | \$240,000 | June 1976-<br>Dec. 1981   | Multisystems, Inc.                              | James S. K. Yu<br>(202) 426-4060    |
| Future of Large American Cities   | DC-06-0221    | \$127,542 | Aug. 1978-<br>Dec. 1981   | Brookings<br>Institution                        | James S. K. Yu<br>(202) 426-4060    |
| Means for Reducing Light Rail Transit Cost Through Standardization of System Elements | IT-06-0103-03 | \$55,000  | Sept. 1976-<br>Dec. 1981  | DeLeuw Cather<br>and Co.                        | James S. K. Yu<br>(202) 426-4060    |
| Study of Methods of Improving LRT Service   | IT-06-0103-02 | \$53,000  | Sept. 1976-<br>Dec. 1981  | DeLeuw Cather<br>and Co.                        | James S. K. Yu<br>(202) 426-4060    |
| Local Parking Management Policies and Practices                                       | DC-06-0225    | \$39,974  | Sept. 1978-<br>Sept. 1981 | Public Technology<br>Inc.                       | James S. K. Yu<br>(202) 426-4060    |
| Development of an Urban Mobility Research Center                                      | TX-06-0041    | \$150,000 | Sept. 1982-<br>Sept. 1983 | Rice Center                                     | James S. K. Yu<br>(202) 426-4060    |
| State Role in Transit   | MA-06-0109    | \$60,000  | Oct. 1979-<br>Sept. 1980  | TSC   | Fred L. Williams<br>(202) 426-4004  |

## Bibliography

A list of recent reports follows. Please consult previous editions of this Directory for earlier reports. If available, a document number assigned by the National Technical Information Service (NTIS) is listed. Reports may be obtained from NTIS by using the order blanks provided at the end of this document.

Reports which have not been assigned an NTIS number may not have been published in sufficient quantity for general distribution. Single copies and other information may be available from the issuing agency or organization.

Additional reports relating to the research described in this chapter may become available in the near future. For the most recent information or suggestions for additional reference materials regarding specific projects, call or write to the person listed as the technical contact in the Project Summary Table.

### POLICY DEVELOPMENT

#### **Urban Public Transportation and Energy**

Proj. IT-06-0170  
System Design Concepts  
October 1979

#### **An Evaluation of Making Rail Transit Systems Accessible to Handicapped Persons**

Proj. DC-06-0310  
Transportation Systems Center  
April 1980

#### **Taxicabs and Federal Programs: A Handbook**

Proj. MD-06-0073  
Public Technology, Inc.  
March 1980

#### **Taxicab Operating Characteristics**

Proj. MD-06-0080

International Taxicab Association  
December 1981

#### **Issues in Taxi-Based Specialized Transit Service**

Proj. CA-06-0153  
University of California at Irvine  
January 1982

#### **Rail Access Retrofit Study**

Proj. DC-06-0310  
DeLeuw Cather and Co.;  
Barson, Brinkeroff, Quade and Douglas;  
Crain and Associates  
December 1980

#### **Recent Efforts to Enact Dedicated Revenue Sources**

Proj. DC-06-0429  
Jeffrey A. Parker  
September 1982

### POLICY RESEARCH

#### **Joint Development: Making the Real Estate-Transit Connection Executive Summary**

Proj. DC-06-0183  
Urban Land Institute with Gladstone Associates  
June 1979, PB 80-163-454

#### **Joint Development: Making the Real Estate-Transit Connection**

Proj. DC-06-0183  
Urban Land Institute with Gladstone Associates  
June 1979, PB 80-169-683

#### **Financing Transit: Alternatives for Local Government**

Proj. IT-06-0127  
Institute of Public Administration  
December 1979, PB 80-129-331

#### **Innovative Transit Financing**

Proj. IT-06-0127  
Gladstone Associates  
November 1979, PB 80-125-537

#### **The Trolley Coach Development and State-of-the-Art: Electric Trolley Bus Feasibility Study**

Proj. IT-06-0193  
Chase, Rosen and Wallace, Inc.  
October 1979, PB 80-104-870

#### **Urban Rail in America: An Exploration of Criteria for Fixed-Guideway Transit**

Proj. NY-06-0061  
Regional Plan Association, Inc.  
November 1980

#### **Trolley Coach: Potential Market, Capital, and Operating Costs: Impacts and Barriers**

Proj. IT-06-0193  
Chase, Rosen and Wallace, Inc.  
June 1980, PB 81-120-172

#### **Urban Decline and the Future of Large American Cities**

Proj. DC-06-0221  
Brookings Institute  
May 1982

#### **Means for Reducing Light Rail Transit Costs through Standardization of System Elements**

Proj. IT-06-0103-03  
DeLeuw Cather and Company  
December 1981

#### **Study of Methods of Improving LRT Service**

Proj. IT-06-00-0103-02  
DeLeuw Cather and Company  
December 1981

#### **Paratransit Services for the Handicapped Individual**

Proj. DC-06-0150  
Multisystems, Inc.  
April 1982, DOT-I-82-18

#### **Free Enterprise Urban Transportation**

Proj. DC-06-0150  
Council for International Urban Liaison  
June 1982



**The European Paratransit Experience**

Proj. FN-06-0004  
Ecoplan International  
October 1981, DOT-I-82-14

**Paratransit for the Work Trip: Commuter Ridesharing**

Proj. DC-06-0150  
Multisystems, Inc.  
January 1982, DOT-I-82-16

**Paratransit in Rural Areas**

Proj. DC-06-0150  
Multisystems, Inc.  
April 1982, DOT-I-82-17

**General Community Paratransit Service in Urban Areas**

Proj. DC-06-0150  
Multisystems, Inc.  
January 1982, DOT-I-82-15

**Local Parking Management Policies and Practices**

Proj. DC-06-0225  
Public Technology, Inc.  
September 1981

**The UMTA Rail Modernization Program, Evaluation of the Impact of Section 3 Capital Grants for Rail Rehabilitation and Modernization, 1965-1977**

Proj. IT-06-0118  
Peak, Marwick, Mitchell and Company  
June 1979, PB 80-178-775

**The Cost of Making Urban Rail Transit Accessible to the Handicapped**

Proj. IT-06-0118  
Peak, Marwick, Mitchell and Company  
October 1979

**The Journey to Work in the United States: 1975**

Proj. DC-06-0124  
Bureau of the Census  
Series P-23, No. 99  
July 1979

**States in Public Transportation: An Analysis Based on Nine Case Studies**

Proj. MA-06-0109  
Fred Williams, UMTA  
December 1981

**Assessment of Federal and State Administration of UMTA Section 16(b)(2) Program**

Proj. MA-06-0109  
Transportation Systems Center  
October 1981

**Urban Initiatives Program Evaluation**

Proj. TX-06-0028  
Rice Center  
November 1981

# University Research and Training Grant Program

---

## Trends and Highlights



The UMTA University Research and Training Program, authorized by Section 11(a) of the Urban Mass Transportation Act, is designed both to take advantage of and to enrich the research and training capabilities of the academic community. By promoting university research and training, and by encouraging and supporting increased interaction between universities and local transportation and planning agencies, UMTA hopes to enhance state and local ability to plan, build and operate transportation systems and services.

Program activities range from theoretical research aimed at advancing basic knowledge to the provision of educational and training opportunities for both students and practicing professionals. Study and research results are used in the solution of urban transportation problems by transportation and planning agencies, UMTA, state DOT's and consultants. Reflecting an increased concern about the need for professionally trained transit personnel, the training and educational aspects of the program are intended to encourage students to pursue undergraduate and graduate studies leading to careers in urban transportation. Students take an active role in the research and training activities; intern programs have been set up to enable students to acquire transit-related work experience while still in school.

A portion of the Section 11 funds is used toward research and training grants awarded in an annual competitive process. In addition to this aspect of the program, eight University Centers for Transit Research and Management Development were established in 1982. These centers make a broad spectrum of expertise avail-

able to the transit industry in its efforts to increase productivity and efficiency. They supplement other federally funded programs by providing short-term management and technological support, while also offering long-term management research and academic opportunities to the transit community. In addition, the Center provides continuing-education courses for transit officials on various management and operations issues, industry-approved professional certification programs, and undergraduate and graduate programs which are responsive to transit management needs.

In order to expand the capabilities and participation of minority institutions in urban transportation research and training, three summer workshops have been held to provide faculty from such institutions with urban transit research experience. A total of 42 academicians have participated to date in these intensive training exercises and have returned to their institutions to initiate various transit-related research activities.

## University Centers for Transit Research and Management Development

As UMTA seeks to enhance transit research and management development capabilities at the university level, the "Centers" concept has been selected as a promising mode for the utilization of multi-disciplinary experiences. It is also a means by which: 1) UMTA's University Research and Training Program and its Management Training Program can be

more fully developed and; 2) state and local agencies including transit operators can be favorably included as active participants in all aspects of the Centers' operations.

UMTA's financial support to eight Centers provides the means whereby each institution will create, operate and finance a transit research and management development center. Each institution will identify sources of local funds available to assist in the development of a Center. Also to be identified are relevant courses already in place, what curriculum materials could be developed, how the Center would become self-sustaining (eventually), how the local transit operator(s) would be involved, and how advisory or steering committees would be established and utilized. The first courses to be offered within the Centers' operations are scheduled for the 1982-1983 academic year.

### The Centers

Institute of Transportation Studies  
University of California at Irvine  
Irvine, CA 92717  
Principal: Dr. G.J. (Pete) Fielding  
(714) 833-5448

New York Institute of Technology  
Old Westbury, NY 11568  
Principal: Dr. Richard Dibble  
(516) 686-7722

Center for Urban Studies  
Portland State University  
Portland, OR 97202  
Principal: Dr. Kenneth Dueker  
(503) 229-4043

The Wharton School  
University of Pennsylvania

Philadelphia, PA 19104  
Principal: Dr. Howard Mitchell  
(215) 898-7818

Texas Southern University  
Houston, TX 77004  
Principal: Dr. Naomi Lede  
(713) 527-7282

Florida A&M University  
Tallahassee, FL 32307  
Principal: Mr. Addis Taylor  
(904) 599-3600

University of Michigan  
Ann Arbor, MI 48109  
Principal: Dr. George Gamota  
(313) 764-6200

Indiana University  
Bloomington, IN 47405  
Principal: Dr. George Smerk  
(812) 335-8143

### Areas of Emphasis

University of California at Irvine

Develop analytical techniques to facilitate access to Section 15 data base; analyze impact of ownership and management forms on transit operator performance and productivity; training activities for middle managers, industrial relations managers, operations supervisors and smaller transit property operators.

Florida A&M University

Management strategies to identify and implement training programs responsive to needs of industry; integration of university academic programs into industry human resources requirements; research role of public transit in economic development of Southeastern U.S.; and profile paratransit and small urban area issues.



Indiana University at Bloomington

Professional development seminars in financial management, labor relations, and managerial techniques; micro-computer research techniques; and technology transfer in financial management strategies.

University of Michigan

Research on instrumentation of maintenance problem detection; acquisition of maintenance data; optimization of equipment replacement strategies; micro-computerization of traffic engineering methods; and information transfer on Section 15 data analysis and operations.

New York Institute of Technology

Undertake a management development program to assist transit operators in the upgrading of their workforce; initiate labor relations training for transit managers and supervisors; develop a transportation management degree/certificate program; deliver technical and maintenance training packages for transit systems operators; and identify and implement internship and cooperative education positions with private and public transportation agencies and companies in New York City regional area.

University of Pennsylvania—The Wharton School

Conduct series of training courses and seminars in human resources development for industry senior executives, board members and human resources practitioners; research factors which influence the transfer of training; study managerial productivity and efficiency;

and examine strategies to reduce bus operations costs.

Portland State University

Research transit career patterns, experiences and training needs; cost effectiveness of articulated buses; private-public cooperation in the delivery of transit services; training activities in labor-arbitration matters, innovative transit services and small city transit management techniques; and clearinghouse function in technology transfer among regional transit operators and universities.

Texas Southern University

Develop and conduct a program of graduate and undergraduate instruction leading to M.Sc. in transportation; provide continuing education and training courses for industry employees; establish internship and co-op activities; identify and conduct interdisciplinary research projects; and, assist region or state in exchange of research information.

## FY 82 Project Grants

Descriptions of project grants awarded by the program during FY 82, appear below. Reports published in FY 82 as part of the University Research Program are listed at the end of the Chapter.

### Efficiency and Productivity

#### **A Project Designed to Increase Level of Public Transit Patronage Among Specialized Groups** (TX-11-0014)

Funding: \$122,662  
Schedule: July 1982-July 1983

Grantee: Texas Southern University  
(Dr. Naomi Lede)

Technical Monitor: Ross Adams  
(202) 426-9267

#### **Development of Case Study Material Documenting Bus Maintenance Planning and Practice at Selected Transit Properties**

(IL-11-0030)

Funding: \$82,277

Schedule: July 1982-August 1983

Grantee: University of Illinois at Chicago Circle  
(Dr. James F. Foerster)

Technical Monitor: A.B. Hallman  
(202) 426-9274

#### **Innovation and Incremental Improvement in Bus Transit Passenger Data Collection**

(WI-11-0008)

Funding: \$83,035

Schedule: July 1982-July 1983

Grantee: University of Wisconsin at Madison  
(Dr. Robert L. Smith)

Technical Monitor: Brian McCollom  
(202) 426-9271

#### **A Comparative Study of Public Transit Promotion**

(NY-11-0026)

Funding: \$36,710

Schedule: July 1982-July 1983

Grantee: Rensselaer Polytechnic Institute  
(Dr. Mark D. Abkowitz)

Technical Monitor: Mary Martha Churchman  
(202) 426-4984

#### **Efficiency and Productivity Studies in Urban Mass Transportation**

(PA-11-0029)

Funding: \$84,711

Schedule: July 1982-July 1983

Grantee: University of Pennsylvania  
(Dr. Anthony R. Tomazinis)

Technical Monitor: Phil Hughes  
(202) 426-9157

**Assessment and Control of Transit Operator Absenteeism**

(PA-11-0028)

Funding: \$84,550

Schedule: July 1982-August 1983

Grantee: Pennsylvania State University  
(Dr. Rick Jacobs)

Technical Monitor: Alice Royal  
(202) 426-0080

**Feasibility of Adopting Quality Control Circles for Improving Productivity and Service Quality**

(DC-11-0014)

Funding: \$57,356

Schedule: July 1982-June 1983

Grantee: Howard University  
(Dr. M.T. Vaziri)

Technical Monitor: Marvin Futrell  
(202) 426-2053

**Urban Transportation Planning**

**Small City Transit Strategies under New Federalism**

(IN-11-0007)

Funding: \$84,981

Schedule: July 1982-August 1983

Grantee: Purdue University  
(Dr. Jon Fricker)

Technical Monitor: Fred Williams  
(202) 426-6385

**Bus Route Demand Analysis**

(OK-11-0003)

Funding: \$60,328

Schedule: July 1982-July 1983

Grantee: University of Oklahoma  
(Dr. Allen R. Cook)

Technical Monitor: Tom Hillegass  
(202) 426-9271

**An Evaluation of the Impact of a "Publico" Terminal Facility on Urban Transportation**

(PR-11-0003)

Funding: \$80,865

Schedule: July 1982-September 1983

Grantee: University of Puerto Rico  
at Mayaguez

(Dr. Filipe Luyanda)

Technical Monitor: Paul Fish

(202) 426-4984

**Oil Deregulation and its Impacts on Public Transportation Fuel Supply**

(NY-11-0027)

Funding: \$84,723

Schedule: July 1982-August 1983

Grantee: Polytechnic Institute of  
New York

(Dr. William R. McShane)

Technical Monitor: Richard Steinmann  
(202) 426-4004

**Urban Transportation Planning: An Organizational Assessment in the Delivery of Public Transportation Service**

(FL-11-0006)

Funding: \$49,988

Schedule: July 1982-July 1983

Grantee: Edward Waters College  
(Vincent V. Jackson)

Technical Monitor: Yvonne Griffin  
(202) 426-4058

**Training Courses**

**Management Training and Development Program for the Public Transportation Industry**

(IN-11-0008)

Funding: \$90,000

Schedule: July 1982-July 1983

Grantee: Indiana University  
(Dr. George M. Smerk)

Technical Monitor: Ronald Fisher  
(202) 426-9271

**Labor Relations Training for Urban Mass Transit Managers**

(NY-11-0028)

Funding: \$45,503

Schedule: July 1982-July 1983

Grantee: New York Institute of  
Technology

(Dr. Richard E. Dibble)

Technical Monitor: Brian Cudahy

(202) 472-2440

**Training Course to Upgrade Urban Mass Transit Management**

(OH-11-0006)

Funding: \$88,530

Schedule: July 1982-July 1983

Grantee: Ohio State University  
(Dr. James B. Hamilton)

Technical Monitor: Nat Jasper  
(202) 426-0080

**A Training Course for Public Transit Professionals in Small and Medium Size Cities**

(MA-11-0040)

Funding: \$84,585

Schedule: July 1982-June 1983

Grantee: University of Massachusetts,  
Amherst, and Alabama State  
University

(Dr. Paul W. Schuldiner and  
Dr. Thomas Knight)

Technical Monitor: Judy Meade  
(202) 426-0080

**Training Program for Small Rural Transportation Systems**

(CA-11-0025)

Funding: \$19,624

Schedule: July 1982-August 1983

Grantee: California State University  
at Chico

(Dr. Thomas Ferrara)

Technical Monitor: Charles Morison  
(202) 426-0080

**Urban Transportation Economics**

**Local and State Responses to the Proposed Loss of Federal Transit Operating Assistance**

(TN-11-0006)

Funding: \$50,322

Schedule: July 1982-August 1983  
Grantee: University of Tennessee  
(Dr. David Arbeit)  
Technical Monitor: Jack Bennett  
(202) 426-4058

**State and Local Government Responses to Increased Financial Responsibility for Public Transit Systems**

(NC-11-0012)  
Funding: \$78,697  
Schedule: July 1982-June 1983  
Grantee: North Carolina A&T State University  
(Erskine S. Walther)  
Technical Monitor: Eric Bers  
(202) 426-4058

**Special Transportation Services**

**A Study to Assess the Importance of Personal, Social, Psychological and Other Factors in Ridesharing Programs**

(MD-11-0005)  
Funding: \$65,623  
Schedule: July 1982-June 1983  
Grantee: Morgan State University  
(Dr. Hubert Nyame-Mensah)  
Technical Monitor: Roger Tate  
(202) 426-4984

**Analysis of Issues in Consolidation of Special Elderly and Handicapped Transportation Services**

(DC-11-0016)  
Funding: \$84,874  
Schedule: July 1982-June 1983  
Grantee: Howard University  
(Dr. Errol C. Noel)  
Technical Monitor: Roger Tate  
(202) 426-4984

**Taxicab Regulations: Removing the Barriers to Private Sector Involvement in Transit**

(NC-11-0011)  
Funding: \$71,385  
Schedule: July 1982-August 1983

Grantee: University of North Carolina,  
Chapel Hill  
(Dr. Gorman Gilbert)

Technical Monitor: Paul Fish  
(202) 426-4984

**Taxi Regulation in a Free Entry Market: A Case Study of Washington, D.C.**

(DC-11-0015)  
Funding: \$76,853  
Schedule: July 1982-July 1983  
Grantee: University of the District of Columbia  
(Deborah L. Lyons)  
Technical Monitor: Larry Bruno  
(202) 426-4984

**Section 15 Reporting System**

**Application of Section 15 and Census Data to Transit Decisions**

(KY-11-0002)  
Funding: \$80,457  
Schedule: July 1982-July 1983  
Grantee: University of Kentucky  
(Dr. M. Vaziri)  
Technical Monitor: Ronald Fisher  
(202) 426-9157

**Performance Indicators and Peer Groups for Comparison of Transit Properties**

(CA-11-0026)  
Funding: \$84,999  
Schedule: July 1982-June 1983  
Grantee: University of California at Irvine  
(Dr. G.J. Fielding)  
Technical Monitor: Ronald Fisher  
(202) 426-9157

**Development of Transit System Productivity Measures Based Upon Section 15 and Urban Area Environmental Data**

(FL-11-0007)  
Funding: \$82,770  
Schedule: July 1982-August 1983  
Grantee: Florida State University  
(Dr. Andrew Dzurik)

Technical Monitor: Ronald Fisher  
(202) 426-9157

**Transit System Boards Of Directors**

**A Comprehensive Analysis of the Role, Operations and Functions of the MARTA Board of Directors as Compared with the Dade County Board of Directors**

(GA-11-0013)  
Funding: \$84,997  
Schedule: July 1982-June 1983  
Grantee: Atlanta University  
(Dr. Robert A. Holmes)  
Technical Monitor: A.B. Hallman  
(202) 426-9274

**Bibliography**

This list identifies final research reports published by UMTA's University Research and Training (URT) Program through September 1982 and not included in the December 1979 Supplement to Abstracts for "University Research Projects." A National Technical Information Service (NTIS) order number is indicated for each report.

Reports generated by current URT projects listed elsewhere in this chapter may become available in the future. For further information, call or write to the technical contact given for each project listing.

**EFFICIENCY AND PRODUCTIVITY**

**Comparative Analysis of Transit Performance**

Proj. CA-11-0020-82-1  
University of California at Irvine  
January 1982, PB 82-196478



**Development and Implementation of Dynamic Methodologies for Evaluating Energy Conservation Strategies**

Proj. MN-11-0004-82-2  
University of Minnesota  
April 1982, PB 82-240763

**Development of Transit Bus Component Failure Statistics from Conventional Bus Card Records: Executive Summary**

Proj. IL-11-0028-82-1  
University of Illinois at Chicago Circle  
February 1982, PB 82-218686

**Development of Transit Bus Component Failure Statistics from Conventional Bus Card Records: Final Report**

Proj. IL-11-0028-2  
University of Illinois at Chicago Circle  
February 1982, PB 82-218694

**Timed Transfer System Planning, Design and Operation**

Proj. PA-11-0021-82-2  
University of Pennsylvania  
October 1981, PB 82-220146

**Train Crew Reduction for Increased Productivity of Rail Transit: Executive Summary**

Proj. PA-11-0023-82-1  
University of Pennsylvania  
February 1982, PB 82-225863

**Train Crew Reductions for Increased Productivity of Rail Transit: Final Report**

Proj. PA-11-0023-82-2  
University of Pennsylvania  
February 1982, PB 82-225871

**Urban Transportation Energy Accounts Vol. I. Procedures Manual Vol. II. Case Study of the Chicago Region**

Proj. IL-11-0027-81-1  
University of Illinois at Urbana-Champaign  
September 1981, PB 82-135542

**URBAN TRANSPORTATION PLANNING/ECONOMICS**

**A Methodology for Locating and Sizing Transit Fixed Facilities and the Detroit Case Study**

Proj. MI-11-0004-82-1  
Wayne State University  
January 1982, PB 82-179391

**A Strategic Perspective on Public Transportation in a Time of Uncertain Petroleum Supply**

Proj. CA-11-0021-82-1  
University of California at Berkeley  
June 1981, PB 82-176918

**An Examination of Coordination Methods for Transportation Planning Activities**

Proj. WI-11-0007-82-1  
University of Wisconsin, Milwaukee  
April 1982, PB 82-223991

**Dynamic Analysis of Attitude-Behavior Response to Transportation Service Innovation**

Proj. IL-11-0012-82-3  
Northwestern University  
December 1981, PB 82-20-202367

**Effect of Budgetary Constraints on Transit System Performance**

Proj. PA-11-0022-82-2  
University of Pennsylvania  
January 1982, PB 82-201013

**Equity in Transit Finance: A Quantitative Assessment of the Impacts of Transit Subsidies on Low-Income and Minority Groups**

Proj. NJ-11-0010-82-1  
Rutgers University  
November 1981, PB 82-158106

**Guide to Forecasting Travel Demand With Direct Utility Assessment**

Proj. NH-11-0001-82-1  
Dartmouth College  
September 1981, PB 82-200270

**Long Range Prospects and Requirements of Urban Public Transportation**

Proj. PA-11-0019-82-2  
University of Pennsylvania  
June 1981, PB 82-230855

**Los Angeles County Transportation Commission Public Policy Impact Study (1977-1980)**

Proj. CA-11-0002-81-1  
California State University at Long Beach  
April 1981, PB 82-151523

**Transportation During the Next Energy Crisis: The Special Problems of Small Urban Areas: Executive Summary**

Proj. NY-11-0023-81-5  
Polytechnic Institute of New York  
June 1981, PB 82-179425

**Transportation During the Next Energy Crisis: The Special Problems of Small Urban Areas: Final Report**

Proj. NY-11-0023-81-6  
Polytechnic Institute of New York  
June 1981, PB 82-179433

**SPECIAL TRANSPORTATION SERVICES**

**Consumer Preference for Alternative Transit Service Concepts at Regional Shopping Centers: An Initial Assessment**

Proj. WA-11-0008-82-1  
University of Washington  
October 1981, PB 82-208711

**Coordination of Paratransit: Case Studies of Special Transportation Agencies**

Proj. IL-11-0028-82-4  
University of Illinois at Chicago Circle  
February 1982, PB 82-219148

**Decision Procedures for Paratransit Market Selection and Service Evaluation**

Proj. VA-11-0010-82-2  
University of Virginia  
May 1982, PB 82-259268

**Improving Communications with the  
Visually Impaired in Rail Rapid Transit  
System**

**Vol. I. Solutions for Problems of  
Visually Impaired Users of Rail Rapid  
Transit**

**Vol. II. Information about Visual  
Impairment for Architects and Transit  
Planners**

Proj. MA-11-0036-81-1,2

Boston College

August 1981, PB 82-165564 and 165572

**Innovation in Urban Transportation:  
A Case Study**

Proj. PA-11-0022-82-1

University of Pennsylvania

November 1980, PB 82-201005

**Integration of AGT Systems with Other  
Transportation Modes**

Proj. WV-11-0003-82-2

West Virginia University

December 1981, PB 82-255621

Power and Energy Measurement on

Morgantown People Mover System

Proj. WV-11-0003-83-1

West Virginia University

December 1981, PB 82-255647

**Ridership Patterns in Transportation  
Services for the Elderly and Handicapped**

Proj. TX-11-0011-82-1

University of Texas at Austin

September 1981, PB 82-168808

# Appendixes



# APPENDIX A

## Sources of Technical Assistance Information

### National Technical Information Service

Many of the reports on UMTA R&D described in this volume are available for purchase from the National Technical Information Service (NTIS). NTIS is the principle repository and disseminating agency for all reports issued in conjunction with federal research and development activities.

NTIS will fill orders for publications in stock within three days; documents which must be reprinted will be mailed within two weeks. Most reports in NTIS are also available on microfiche.

A copy of the NTIS mail order form appears at the end of this document and should be used for ordering reports from NTIS. Information on how to purchase documents may be obtained by calling (703) 487-4560 (regular orders) or (703) 487-4700 (rush orders) or by writing to:

U.S. Department of Commerce  
National Technical Information  
Service  
5285 Port Royal Road  
Springfield, VA 22161

### Transit Research Information Center

Another repository for UMTA reports is the Transit Research Information Center (TRIC), located within UMTA's Office of Technical Assistance. TRIC maintains a full collection of all UMTA-sponsored reports and provides, upon request, a one-page technical abstract of any report. It is also possible to request abstracts of all UMTA reports related to a specific topic.

Through 1980, TRIC published annual compendiums of reports pertaining to work performed under UMTA R&D grants and contracts, technical studies grants, and university research and training grants in a document entitled *Urban Mass Transportation Abstracts*. These Abstracts include condensed descriptions of UMTA reports available for purchase through NTIS. Each volume is indexed by title, individual and corporate author, geographic area, project number and subject. These reports are available from NTIS beginning with Volume I, (1972) through Volume VII (1980).

Since 1980 this information has been transmitted to the TRB-administered Urban Mass Transportation Information System (UMTRIS) data base. UMTRIS first published the *Urban Mass Transportation Abstracts—Cumulative Bibliography 1974-1980*, in April 1982. It includes the UMTA reports submitted by TRIC as well as research reports from other sources. Installments of the bibliography, available from TRB, are published semi-annually. For information pertaining to the UMTRIS data base, contact:

Fred M. Houser  
Transportation Research Board  
2101 Constitution Avenue, N.W.  
Washington, DC 20418  
(202) 334-3263

The bi-monthly edition of UMTA Abstracts, listing the most recent UMTA reports, is still issued through TRIC. A cumulative retrieval term index appears at the end of every third bi-monthly abstract. These documents may be obtained from:

Marina Drancsak or Winnie Muse  
U.S. Department of Transportation  
Urban Mass Transportation

Administration  
Office of Technical Assistance  
Transit Research Information Center  
400 Seventh Street, S.W.  
Washington, DC 20590  
(202) 426-9157

### Technology Sharing

Several offices within the U.S. Department of Transportation sponsor technology sharing programs to assist state and local governments, transportation agencies, industry, the research community and the public. Workshops and training programs are sponsored and conducted, and documents containing information drawn from a variety of sources are issued. These activities are designed to help local agencies in the evaluation and introduction of new methods and technologies as well as to provide opportunities for representatives of the transit industry to discuss successful and unsuccessful experiences in problem solving.

Reports prepared for UMTA by the Office of Technology Sharing at the Transportation Systems Center (TSC) in Cambridge, Mass., are free upon request while copies are available. When supplies are exhausted, reprints may be ordered through NTIS, or in some cases from the Superintendent of Documents, U.S. Government Printing Office, Washington, D.C. 20402.

The TSC Office of Technology Sharing has two toll-free numbers to call for current information. These are:

(800) 842-1151 (for calls  
within Massachusetts)  
(800) 225-1612 (for calls  
outside Massachusetts)

Documents may be ordered by title from:

U.S. Department of Transportation  
Transportation Systems Center  
Office of Technology Sharing,  
DTS-31  
Kendall Square  
Cambridge, MA 02142

Other technology sharing publications are available from the U.S. Department of Transportation's Office of Technology and Planning Assistance. Copies of these documents may be obtained by calling (202) 426-4208 or by writing to:

U.S. Department of Transportation  
Office of the Assistant Secretary  
to Governmental Affairs  
Office of Technology Planning and  
Assistance, I-30  
400 Seventh Street, S.W.  
Washington, DC 20590

The Federal Highway Administration (FHWA) has prime responsibility for the rural and small city transit programs authorized in Section 18 of the Urban Mass Transportation Act of 1964, as amended. The FHWA has developed summary information packages, many of which are useful to larger urban transportation agencies. The FHWA has established a technology transfer coordinator in its Division Offices located in each state, usually in the state capital. Initial inquiries about the FHWA's technology sharing products and activities should be made at these offices. General information about FHWA technical programs may also be obtained from:

Office of Implementation, HRT-1  
Federal Highway Administration  
Implementation Division, HDV-20  
400 Seventh Street, S.W.  
Washington, DC 20590

### **UMTA Public Information Service**

UMTA conducts an active public information program through its Office of Public Affairs. Press releases and brochures describing various UMTA programs and policies are available upon request from:

U.S. Department of Transportation  
Urban Mass Transportation  
Administration  
Office of Public Affairs  
400 Seventh Street, S.W.  
Washington, DC 20590

UMTA activities are also reported regularly in a magazine published by the U.S. Department of Transportation entitled *Transportation USA*. This magazine is available from the Superintendent of Documents, U.S. Government Printing Office, Washington, DC 20402.

### **Congressional Hearings**

An abundance of factual and statistical data concerning the current UMTA program and plans for the future is submitted each year to the U.S. Senate and House of Representatives Appropriations Committee(s). This material, plus a transcript of additional information obtained in hearings, constitutes a comprehensive record of UMTA activities. Copies may be obtained from:

U.S. Senate  
Committee on Appropriations  
Subcommittee on Transportation  
Washington, DC 20510

and

U.S. House of Representatives  
Committee on Appropriations  
Subcommittee on Transportation  
Washington, DC 20515

### **U.S. Department of Transportation (DOT) Library**

The DOT library houses all reports published by UMTA and contains approximately 500,000 books and other documents, and some 170 drawers of vertical file material. More than 1500 periodicals are received annually. Most materials are available through inter-library loan. The library is located in the main building of the U.S. Department of Transportation at 400 Seventh Street, S.W., Washington, DC 20590.

### **UMTA Files**

In conformance with the Freedom of Information Act, UMTA has established a facility for document inspection within the Office of Public Affairs, open to the public during normal working hours. The following records are available for inspection:

- Final opinions and orders made in the adjudication of cases and issued within UMTA;
- Any policy or interpretation issued by UMTA, if that policy or interpretation can reasonably be expected to have value as a precedent in any case involving a member of the public;
- Any administrative staff manual or instruction to staff which affects any member of the public;
- An index to the material described above.

Any person desiring to inspect such a record, or to obtain a copy, must submit a written request (and, in the case of photocopies, the appropriate fee) to:

U.S. Department of Transportation

Urban Mass Transportation  
Administration  
Director of Public Affairs  
400 Seventh Street, S.W.  
Room 9330  
Washington, DC 20590

### **Correspondence**

UMTA is responsive to letters of inquiry. Communications addressed to the UMTA Administrator will be routed to the appropriate offices for reply. Communications should be sent to:

U.S. Department of Transportation  
Urban Mass Transportation  
Administration  
Office of the Administrator  
400 Seventh Street, S.W.  
Washington, DC 20590



# APPENDIX B

## Urban Mass Transportation Grants and Contracts: Application and Procurement Procedures

### Introduction

The U.S. Department of Transportation issues a publication entitled *Contracting with the Department of Transportation* (DOT P 4200.1) which provides information intended for organizations desiring to do business with the government. The pamphlet is not a substitute for the official rules and regulations governing procurement, but presents useful background information and serves as an initial guide to DOT procurement policies.

The document is available free of charge from:

U.S. Department of Transportation  
Office of the Secretary  
Procurement Operations Division,  
M-43  
400 Seventh Street, S.W.  
Washington, DC 20590

### Grants and Cooperative Agreements

Grants, which are usually awarded to state or municipal governments, transit properties, universities or non-profit organizations, are made in cases where the primary purpose of the funding is to benefit the grant recipient's own project or program rather than to benefit a government project or program.

A grant award is essentially a two-step process involving the UMTA Administrator's approval of a project and the amount of the grant deemed necessary to accomplish it, followed by the execution of a grant agreement which becomes the

basic document describing the mutual obligations of the government and the grantee with respect to the project.

The Federal Grant and Cooperative Agreement Act of 1977 provides for still another funding instrument—the cooperative agreement, used when the primary purpose is to distribute federal benefits to a client organization but with substantial federal involvement in the execution of the agreement.

Those interested in applying for a grant or conducting a cooperative agreement should follow the guidance provided by UMTA Circular 6100.1, July 9, 1979, entitled *Application Instructions for Section 6, Research, Development, and Demonstration (RD&D) Grants and Cooperative Agreements*. This can be obtained by calling or writing to:

U.S. Department of Transportation  
Urban Mass Transportation  
Administration  
Office of Administrative Services,  
UAD-12  
400 Seventh Street, S.W.  
Washington, DC 20590  
(202) 426-4865

A reading copy is available in the UMTA Office of Public Affairs at the same address.

### Contract Procurement

Contracts are used when the purpose of the funding is to acquire goods or services needed by UMTA to carry out its own programs.

The contract procurement process is circumscribed by an extensive body of federal contract law. Any firm wishing to do business with the federal government should have ready access to the federal

procurement regulations. A copy of Title 41 of the *Code of Federal Regulations* may be obtained at nominal cost from the Superintendent of Documents, U.S. Government Printing Office, Washington, DC 20402.

In contract procurements, DOT tries to obtain the maximum amount of competition consistent with efficient administration practices. This includes, as appropriate, notifying all interested suppliers on its Bidders' Mailing List (described below) as well as any other known suppliers of the procurement, and placing notice of the procurement in public places, including the U.S. Department of Commerce publication, *Commerce Business Daily*.

### Bidders' Mailing List

Each DOT procurement office tries to obtain as many contractor sources for supplies and services as possible. To do so, each maintains a Bidders' Mailing List which identifies the equipment, supplies, materials or services that vendors have available to sell.

To be placed on the Bidders' Mailing List, contractors (other than Architectural and Engineering (A&E) firms) must submit a Standard Form 129, Bidders' Mailing List Application, with complete and exact information about the products or services on which they wish to bid. A&E firms desiring to do work for DOT should submit a Standard Form 254, U.S. Government Architectural and Engineering Questionnaire, to DOT procurement offices.

Copies of the application forms for the Bidders' Mailing List are available at all government procurement offices, and a copy of both SF-129 and SF-254 are attached to the brochure, *Contracting with*

the Department of Transportation (see the Introduction to this Appendix).

To be placed on more than one procurement office Bidders' Mailing List, vendors must file separate forms with each DOT administrative office where they want to be listed. To be listed for UMTA procurements, potential contractors should mail the completed form to:

U.S. Department of Transportation  
Urban Mass Transportation  
Administration  
Program and Operations Support  
Division, UAD-42  
400 Seventh Street, S.W.  
Washington, DC 20590

Notification of all Requests for Proposals (RFP) is made selectively to firms which have claimed special skills or resources closely related to the topics covered by the RFP. All RFP's are recorded in the *Commerce Business Daily*, described below.

### Commerce Business Daily

The *Commerce Business Daily* is designed to help American business firms keep abreast of federal government procurements and general contracting activity. It is published Monday through Friday, except on federal holidays. It lists, by commodity and service, U.S. Government procurement invitations, subcontracting leads, contract awards, sales of surplus property, and other business opportunities. The *Commerce Business Daily* is sold by the Superintendent of Documents, U.S. Government Printing Office, Washington, DC 20402. Subscription blanks may be obtained from:

U.S. Department of Commerce

U.S. Foreign Commercial Service  
Washington, DC 20230

or from the nearest U.S. Department of Commerce field office.

### Subcontracting

Another possible means of participating in UMTA procurements is by subcontracting. In many instances, an UMTA prime contractor uses another firm for professional services, construction or equipment. If a firm considers itself qualified to perform one aspect or part of a project for which another firm has been chosen, the prime contractor can be approached and offered goods or services on a subcontract basis.

The *Commerce Business Daily* is a source of information about contract awards. These are published, for the most part, for the benefit of potential subcontractors.

### Unsolicited Proposals

Prospective DOT contractors can make their new ideas known by submitting an unsolicited proposal to the procurement office which buys the type of item or service being proposed. The prospective contractor does not have to submit an SF-129 or be on the Bidders' Mailing List to submit an unsolicited proposal.

Acceptance of these proposals for evaluation does not imply a promise to pay, a recognition of novelty or originality, or any restriction on the use of information contained therein to which the U.S. Government would otherwise be entitled, nor is the fact that a procurement follows receipt of, or is based on, an unsolicited proposal, in and of itself sufficient to jus-

tify sole source procurement. In cases where the submitter wants technical data which is included in the proposal to be used only for purposes of evaluation, and wishes to retain proprietary interest in such data, certain specific procedures must be followed.

### Minority Business Enterprise (MBE)

DOT actively supports the minority business enterprise (MBE) program established by Executive Order 11625. In each procurement office a minority business liaison official is responsible for providing assistance to minority firms desiring to do business with that office. Contracts are awarded under the Small Business Administration Section 8(a) procedures, and efforts are made to insure that MBE firms have an opportunity to bid or offer proposals for competitive awards. Problems in this program which cannot be resolved with the local officials may be presented to the:

U.S. Department of Transportation  
Office of the Secretary  
Director of Installations and  
Logistics (M-60)  
Washington, DC 20590

### Cost Sharing

In some cases when a grant or procurement contract is awarded, financial participation by the performing organization may be required. The requirement for cost sharing is determined on an individual project basis. The proportion of federal funding support to be supplied to an authorized RD&D project is determined by the Administrator of the Urban Mass Transportation Administration.

## **UMTA University Research and Training (URT) Grants**

University Research and Training (URT) Grants are made to public and private nonprofit institutions of higher learning to assist in carrying out research on problems in urban transportation and to provide professional training in the field of urban transportation analysis, planning, management and operations.

### **URT Applications**

In the late summer, UMTA normally issues an announcement in the *Commerce Business Daily* inviting submittal of URT grant applications.

A formal grant application must contain a detailed outline of the proposed research or training program, as well as a delineation of the program's organization, staff, faculty and budget. When necessary, UMTA personnel can provide informal assistance in interpreting the guidelines and preparing the formal application. An annual announcement brochure including "Instructions for the Preparation of Applications to the University Research and Training Program" is available from:

U.S. Department of Transportation  
Urban Mass Transportation  
Administration  
Office of Technical Assistance,  
URT-32  
400 Seventh Street, S.W.  
Washington, DC 20590

Additional information about the University Research and Training program may be obtained by calling (202) 426-0080.





# Indexes

# AGENCY/CONTRACTOR INDEX

| Agency/Contractor  | Page                              | Agency/Contractor   | Page                       |
|--|-----------------------------------|---|----------------------------|
| <b>A</b>   |                                   |   |                            |
| AAR  | 33                                | Central New York RTA  | 12                         |
| AFL-CIO Appalachian Council, W. Va.                              | 118                               | Central Ohio Transit Authority (COTA)                           | 12, 76                     |
| Albuquerque (N. Mex.) Transit System                             | 106                               | CENTRO (Central New York Regional Transit Authority)            | 118                        |
| Ann Arbor Transportation Authority                               | 83                                | Charles River Associates  | 75, 76, 78, 79, 81, 82, 83 |
| APTA (American Public Transit Association)                       | 12, 32, 132, 139                  | Chase, Rosen and Wallace, Inc.                                  | 74                         |
| Arizona DOT  | 101                               | Chicago (Ill.) Urban Transportation District (CUTD)             | 33, 37                     |
| Arkansas Highway and Transportation Department                   | 79                                | Cleveland State University                                      | 115                        |
| ATE Management and Service Co.                                   | 105                               | COLTS (County of Lackawanna Transit Authority)<br>Scranton, Pa. | 76                         |
| Atlanta (Ga.) Regional Commission                                | 103, 143                          | Commonwealth of Massachusetts                                   | 125                        |
| Atlanta University   | 150                               | COMSIS Corp.  | 75, 76, 82, 83, 101, 102   |
| Automated Sciences Group   | 100, 139                          | Crain and Associates  | 74, 76, 78, 81, 83         |
| <b>B</b>   |                                   |   |                            |
| Baltimore (Md.) Regional Planning Council                        | 101                               | CTA (Chicago Transit Authority), Chicago, Ill.                  | 35, 105                    |
| BART (Bay Area Rapid Transit District),<br>San Francisco, Calif. | 32, 37                            | <b>D</b>  |                            |
| Battelle Columbus Laboratory                                     | 34, 50, 133                       | Dade County, Florida  | 103                        |
| Bechtel Corp.  | 37                                | Dade County (Fla.) Office of Transportation<br>Administration   | 81, 139                    |
| Bi-State Development Agency, Mo.                                 | 80                                | Dallas (Tex.) Transit System                                    | 105                        |
| Birmingham-Jefferson County TA                                   | 79                                | Dartmouth College   | 103                        |
| Boeing Aerospace Co.   | 50                                | Data Communications, Inc.                                       | 36                         |
| Boeing Services International                                    | 33                                | Data Transformation Corp.                                       | 100                        |
| Bolt, Beranek and Newman, Inc.                                   | 33                                | Decision Group  | 32                         |
| Booz, Allen and Hamilton, Inc.                                   | 11, 76, 105, 106<br>119, 132, 133 | Del Green Associates  | 74                         |
| Boston College   | 32                                | DeLeuw Cather and Co.   | 82, 83, 143                |
| Boston, Mass., City of   | 83                                | Dellingham Associates   | 79                         |
| Brevard (Fla.) Transportation Authority                          | 80                                | Delon Hampton Associates  | 37, 38                     |
| Brookings Institution  | 143                               | Denver Civic Ventures   | 78                         |
| Budd Co.   | 32, 34                            | Denver RTD  | 12                         |
| <b>C</b>   |                                   |   |                            |
| Cabot Consulting Group   | 105                               | Detroit, Mich., City of   | 119                        |
| California DOT   | 82                                | District of Columbia DOT  | 104                        |
| California State University                                      | 149                               | Duluth (Minn.) Transit Authority                                | 75                         |
| Cambridge Collaborative  | 33                                | Dynatrend, Inc.   | 11, 13                     |
| Cambridge Systematics, Inc.                                      | 75, 76, 79, 83                    | <b>E</b>  |                            |
| Capital District Transportation Authority,<br>Albany, N.Y.       | 75, 81, 102, 106                  | Ecoplan International   | 143                        |
| Carnegie-Mellon University                                       | 35, 133                           | Ecosometrics, Inc.  | 76, 77, 84                 |
| <b>D</b>   |                                   |   |                            |
| <b>E</b>   |                                   |   |                            |
| <b>F</b>   |                                   |   |                            |
| <b>G</b>   |                                   |   |                            |
| <b>H</b>   |                                   |   |                            |
| <b>I</b>   |                                   |   |                            |
| <b>J</b>   |                                   |   |                            |
| <b>K</b>   |                                   |   |                            |
| <b>L</b>   |                                   |   |                            |
| <b>M</b>   |                                   |   |                            |
| <b>N</b>   |                                   |   |                            |
| <b>O</b>   |                                   |   |                            |
| <b>P</b>   |                                   |   |                            |
| <b>Q</b>   |                                   |   |                            |
| <b>R</b>   |                                   |   |                            |
| <b>S</b>   |                                   |   |                            |
| <b>T</b>   |                                   |   |                            |
| <b>U</b>   |                                   |   |                            |
| <b>V</b>   |                                   |   |                            |
| <b>W</b>   |                                   |   |                            |
| <b>X</b>   |                                   |   |                            |
| <b>Y</b>   |                                   |   |                            |
| <b>Z</b>   |                                   |   |                            |



| Agency/Contractor  | Page            | Agency/Contractor   | Page               |
|--|-----------------|---|--------------------|
| Eugene, OR, City of  | 78              |   |                    |
| Expand Associates, Inc.  | 79              |   |                    |
| <b>F</b>   |                 |   |                    |
| Florida A&M University   | 115, 147        |   |                    |
| Florida DOT  | 13, 80          |   |                    |
| Florida International University                                   | 118             |   |                    |
| Florida State University   | 150             |   |                    |
| Foster Miller Associates, Inc.                                     | 38              |   |                    |
| <b>G</b>   |                 |   |                    |
| Garrett AiResearch   | 11, 34          |   |                    |
| GBTD (Greater Bridgeport Transit District),<br>Bridgeport, Conn.   | 75, 76, 82, 106 |   |                    |
| Glendale, Calif., City of  | 82              |   |                    |
| Goldberg, Zoino and Associates                                     | 37              |   |                    |
| Golden Gate Bridge, Highway and<br>Transportation District, Calif. | 83              |   |                    |
| Greater Cleveland (Ohio) Regional Transit<br>Authority             | 106             |   |                    |
| Greater Hartford Ridesharing Group                                 | 78              |   |                    |
| Greater Portland Transit District                                  | 102             |   |                    |
| Ground Airport Transportation Association                          | 143             |   |                    |
| Group Associated Management Services, Inc.                         | 132             |   |                    |
| <b>H</b>   |                 |   |                    |
| Harold Russell Associates, Inc.                                    | 74, 118         |   |                    |
| Harrington, George and Dunn, Inc.                                  | 36              |   |                    |
| Hawaii DOT   | 78              |   |                    |
| Hermosa Beach, Calif., City of                                     | 78              |   |                    |
| Houston, Tex., City of   | 79              |   |                    |
| Houston (Tex.) Metropolitan Transit<br>Authority (MTA)             | 105             |   |                    |
| Howard University  | 149, 150        |   |                    |
| Huntsville, Ala., City of  | 83              |   |                    |
| <b>I</b>   |                 |   |                    |
| Indiana University   | 115, 147, 149   |   |                    |
| International City Managers Association                            | 74, 125         |   |                    |
| International Taxicab Association                                  | 143             |   |                    |
| <b>J</b>   |                 |   |                    |
|  |                 | Jet Propulsion Laboratory   | 35, 37             |
|  |                 | Johns Hopkins University, Applied Physics<br>Laboratory               | 50                 |
|  |                 | Jordan-DeLaurenti, Inc.   | 118                |
| <b>K</b>   |                 |   |                    |
|  |                 | Kansas City (Mo.) Area Transit Authority                              | 107                |
|  |                 | Kendrick and Co.  | 101                |
|  |                 | Knoxville, Tenn., City of   | 75, 76             |
| <b>L</b>   |                 |   |                    |
|  |                 | Los Angeles, Calif., City of  | 78                 |
|  |                 | Los Angeles County Transportation Commission                          | 83                 |
| <b>M</b>   |                 |   |                    |
|  |                 | Madison, Wis., City of  | 78                 |
|  |                 | Marcom Publications   | 101                |
|  |                 | MARTA (Metropolitan Atlanta Rapid Transit<br>Authority), Atlanta, Ga. | 11, 12, 35, 39, 76 |
|  |                 | Massachusetts Institute of Technology                                 | 34, 36, 100, 103   |
|  |                 | MBTA (Massachusetts Bay Transportation<br>Authority), Boston, Mass.   | 13, 37, 39, 105    |
|  |                 | Medgar Evers Fund, Inc.   | 83, 84             |
|  |                 | Memphis, Tenn., City of   | 79                 |
|  |                 | Memphis Area Transit Authority  | 81                 |
|  |                 | Mercer County, N.J.   | 77                 |
|  |                 | Metro Area Transit, Omaha, Neb.                                       | 76                 |
|  |                 | Metro Suburban (N.Y.) Bus Authority                                   | 11, 12             |
|  |                 | Metropolitan Council of Twin Cities, Minn.                            | 82, 100            |
|  |                 | Metropolitan Transit Commission, Minn. (MTC)                          | 80                 |
|  |                 | Metropolitan Transportation Commission (MTC),<br>Berkeley, Calif.     | 76                 |
|  |                 | Metropolitan Transportation Commission,<br>San Francisco, Calif.      | 104, 107           |
|  |                 | Metropolitan Washington (D.C.) Council<br>of Governments              | 80, 103            |
|  |                 | Miami-Dade County TA  | 118                |
|  |                 | Miami Valley (Ohio) Regional Transit Authority                        | 12                 |
|  |                 | Michigan DOT  | 11, 12, 104        |
|  |                 | Milwaukee (Minn.) County Transit Authority                            | 11                 |
|  |                 | MITRE Corp.   | 50, 77             |

| Agency/Contractor  | Page                          | Agency/Contractor   | Page                  |
|--|-------------------------------|---|-----------------------|
| Montgomery-Greene County Transportation Planning Program, Ohio | 104                           | Peninsula Transportation District Commission, Va.         | 82                    |
| Morgan State University  | 150                           | Pennsylvania State University                             | 75, 79, 149           |
| MTA (Mass Transportation Administration), Baltimore, Md.       | 13, 35, 39                    | Penntan, Hampton, Va.                                     | 80                    |
| Multisystems, Inc.   | 75, 76, 80, 83, 102, 105, 143 | Phoenix, Ariz., City of                                   | 105                   |
| MUNI (San Francisco)   | 13                            | Polytechnic Institute of New York (PINY)                  | 33, 115, 149          |
| Municipality of Metropolitan Seattle, Wash.                    | 105                           | Port Authority of New York and New Jersey                 | 50                    |
| <b>N</b>   |                               | Portland, Oreg., City of                                  | 77                    |
| National Academy of Sciences. See also TRB                     | 36, 39                        | Portland State University                                 | 114, 147              |
| National Institute for Advanced Studies                        | 104                           | Price, Williams and Assoc.                                | 100                   |
| National Mass Transit Institute                                | 115                           | Providence, R.I., City of                                 | 79                    |
| N.D. Lea and Associates  | 32, 34                        | Public Technology, Inc.                                   | 125, 132, 143         |
| N.E. Illinois Regional Transit Authority (RTA)                 | 11, 35, 82, 105               | Puget Sound COG   | 102                   |
| New York Institute of Technology                               | 149                           | Purdue University   | 82                    |
| New York State DOT   | 105, 114, 147                 | <b>Q</b>  |                       |
| Niagara Frontier Transportation Authority, Buffalo, N.Y.       | 11                            | Queen City Metro, Cincinnati, Ohio                        | 76                    |
| North Carolina A&T State University                            | 150                           | <b>R</b>  |                       |
| North Central Texas Council of Governments                     | 102, 104, 105                 | Radiation Sciences  | 36                    |
| Northeastern University  | 115                           | Regents of University of California                       | 118                   |
| Northwestern University  | 77                            | Rensselaer Polytechnic Institute                          | 80, 148               |
| <b>O</b>   |                               | Rhode Island DOT  | 74                    |
| OAO Corp.  | 35, 39, 100                   | Rhode Island Public Transit Authority                     | 12                    |
| Ohio State University  | 149                           | Rice Center   | 101, 143              |
| Onyx Corp.   | 132                           | Rural America, Inc.                                       | 84                    |
| Operations Research, Inc. (ORI)                                | 33                            | Rutgers University  | 77                    |
| Orange County (Calif.) Transit District                        | 81                            | <b>S</b>  |                       |
| Otis Elevator Co.  | 50                            | Sacramento, Calif., City of                               | 75                    |
| <b>P</b>   |                               | Sacramento (Calif.) Regional Transit                      | 75                    |
| Pacific Consultants  | 36                            | St. Louis, Mo., City of                                   | 82                    |
| Parsons, Brinkerhoff, Quade and Douglas                        | 38                            | San Diego (Calif.) Association of Governments             | 103                   |
| PAT, Pittsburgh, Pa.   | 13, 38, 81, 82, 102, 107, 108 | San Diego, Calif., City of                                | 74, 77, 83            |
| PATCO (Port Authority Transit Corporation), Philadelphia, Pa.  | 35                            | San Diego (Calif.) Transit Authority                      | 81, 118               |
| PATH (Port Authority Trans-Hudson), New York, N.Y.             | 38                            | San Diego (Calif.) Transit Corp.                          | 11                    |
| Parker, Jeffrey A.   | 143                           | San Francisco Public Utilities Commission                 | 32                    |
| Peat, Marwick, Mitchell and Co.                                | 82, 104                       | San Rafael, Calif., City of                               | 81                    |
|  |                               | Santa Barbara (Calif.) MTD                                | 13                    |
|  |                               | Santa Clara County, Calif.                                | 100                   |
|  |                               | Santa Clara County (Calif.) Transportation Administration | 11                    |
|  |                               | Santa Cruz County, Calif.                                 | 11, 80, 106, 107, 118 |

| <b>Agency/Contractor</b>   | <b>Page</b>           | <b>Agency/Contractor</b>   | <b>Page</b>                    |
|--|-----------------------|--|--------------------------------|
| SCRTD (Southern California Rapid Transit District)                 | 11, 80, 106, 107, 118 | University of Puerto Rico  | 149                            |
| Seattle, Wash., City of  | 83                    | University of Southern California  | 115                            |
| Seattle (Wash.) Metro  | 13, 102               | University of Tennessee  | 82, 103, 115, 150              |
| SEPTA (Southeastern Pennsylvania Transportation Authority)         | 35, 80, 116, 119      | University of Texas, Austin  | 101                            |
| SG Associates  | 75, 106               | University of Washington   | 115                            |
| South Lake Tahoe, Calif., City of                                  | 80                    | University of Wisconsin, Madison   | 148                            |
| Spokane, Wash., City of  | 75                    | University of Wisconsin, Milwaukee                                       | 115                            |
| Stanford Research Institute (SRI)                                  | 32                    | Urban Institute  | 78                             |
| State University of New York, Buffalo (SUNY)                       | 100                   | Urban Resources, Inc.  | 118                            |
| SYSTAN, Inc.   | 75, 76, 77, 78        | Urban Transportation Development Corp. (UTDC)                            | 37                             |
| Systems Architects, Inc.   | 100                   | Urbitran, Inc.   | 104                            |
| System Design Concepts, Inc.                                       | 132                   | Utah Transit Authority   | 106                            |
| <b>T</b>   |                       | <b>V</b>   |                                |
| Technology Research and Analysis Corp. (TRAC)                      | 12, 32, 77, 139       | Vancouver, Wash., City of  | 76, 77                         |
| Texas Southern University  | 115, 147, 148         | Vera Institute   | 74                             |
| THEM, Inc.   | 83                    | <b>W</b>   |                                |
| TRB (Transportation Research Board)                                | 125, 132, 133         | Wallen and Associates  | 78                             |
| TRIMET (Tri-County Metropolitan Transit District), Portland, Oreg. | 11, 13, 102, 106      | Washington Consulting Group  | 125                            |
| Tri-State Regional Planning Commission, N.Y.                       | 50, 119               | Washington (D.C.) Metropolitan COG's                                     | 80, 103                        |
| Tucson, Ariz., City of   | 75                    | Westinghouse Electric Corp.  | 34                             |
| Tudor Engineering  | 32                    | Western Reserve (Youngstown, Ohio) TA                                    | 79                             |
| Tuskegee, Ala., City of  | 84                    | Wilson-Hill Associates, Inc.   | 32, 81, 100                    |
| <b>U</b>   |                       | Wilson, Ihrig and Associates   | 33                             |
| Unified Industries   | 36                    | WMATA (Washington Metropolitan Area Transit Authority), Washington, D.C. | 35, 37, 38, 39<br>80, 104, 106 |
| University of Arizona  | 37                    | <b>Y</b>   |                                |
| University of California, Berkeley                                 | 39, 77                | Yale University  | 100                            |
| University of California, Irvine                                   | 114, 143, 147, 150    | <b>Federal Agencies</b>  |                                |
| University of the District of Columbia                             | 150                   | Bureau of the Census, U.S. Department of Commerce                        | 101                            |
| University of Illinois, Chicago Circle                             | 148                   | FEMA (Federal Emergency Management Agency)                               | 139                            |
| University of Illinois, Urbana-Champaign                           | 38                    | FHWA (Federal Highway Administration), U.S. Department of Transportation | 38, 39, 100, 101               |
| University of Kentucky   | 150                   | FRA (Federal Railroad Administration), U.S. Department of Transportation | 33, 139                        |
| University of Maryland   | 36, 102               | National Bureau of Standards, U.S. Department of Commerce                | 103                            |
| University of Massachusetts  | 149                   |  |                                |
| University of Michigan   | 101, 115, 147         |  |                                |
| University of North Carolina                                       | 143, 150              |  |                                |
| University of North Florida  | 115, 118              |  |                                |
| University of Notre Dame   | 50                    |  |                                |
| University of Oklahoma   | 149                   |  |                                |
| University of Pennsylvania   | 101, 115, 147, 148    |  |                                |



**Agency/Contractor****Page**

|   |     |
|---|-----|
| National Science Foundation   | 39  |
| TSI (Transportation Safety Institute),<br>U.S. Department of Transportation | 139 |
| U.S. Department of Agriculture  | 84  |
| Veteran's Administration, Rehabilitation Center                             | 32  |

## SUBJECT INDEX

- accelerating walkways, 47
- accessible bus. *See* bus
- Advanced Group Rapid Transit (AGRT), 46
- AGRT, *see* Advanced Group Rapid Transit
- alternative fuels, 7
- alternatives analysis, 130
- American Public Transit Association (APTA)
  - in bus technology, 6
  - in joint safety program, 134, 137
  - in rail standardization, 19
- ATIS, *see* Automated Transit Information System
- auto management techniques, 62
- auto restricted zones, 65
- Automatic Bus Diagnostic System, 115
- Automated Guideway Transit (AGT)
  - cold weather technology, 47
  - linear induction motor, 46
- Automated Transit Information System (ATIS), 68
- Automatic Vehicle Monitoring (AVM), 67
  
- brokerage
  - in elderly and handicapped services, 54
  - in paratransit, 69
- bus systems
  - driver training, 113
  - fare collection, 61
  - accessibility, 6, 54
  - priority treatment, 66
  - RUCUS, 116
  - safety training, 135
  - subscription, 56
- bus vehicles
  - air conditioning, 5
  - articulated, 8
  - battery propulsion, 7
  - brakes, 5
  - electric propulsion, 7
  - flywheel energy storage, 7
  - hybrid, 7
  - lifts, 6
  - noise reduction, 5
  - safety, 135
  - transmissions, 5
- carpool. *See* paratransit
- checkpoint demand-responsive services, 71
- coordinated transportation services for the elderly and handicapped, 54
- cold weather technology, 24, 47
- customer information aids, 68
- dial-a-ride. *See* paratransit
- elderly and handicapped, 54
  - accessibility requirements, 54
  - accessibility to
    - bus, 6, 54
    - rail, 19
  - coordinated services, 54
  - planning services for, 94
  - studies, 150
  - user subsidy, 54
  - vehicles for, 8
- electric trolley bus
  - controller evaluation, 7
  - emergency system, 7
- energy
  - conservation projects, 7, 23, 26
  - contingency planning, 96
- escalators, 24
- fare
  - collection, 5, 25, 61
  - incentives, 56
  - management strategies, 59
  - prepayment, 56
  - pricing, 56
- fire safety, 30, 135, 137
- flywheel, 7
- handicapped. *See* elderly and handicapped
- high occupancy vehicle (HOV), 66
- Host City Program, 53
- human resources, 113
  
- life-cycle costing, 6
- light rail transit, 18, 19, 22, 93, 142
  - See also* rail
- low-density service, 69, 73
  
- maintenance techniques, 17, 28, 29, 115
- marketing, 64
- Methanol, 8
- microcomputers, 89, 91
  
- NBEI Program, 6
- National Cooperative Transit Research Program, 127
- National Technical Information Service (NTIS), 154
- noise abatement, 20
  
- operations management techniques, 91, 115
  
- paratransit
  - brokerage, 54, 69
  - checkpoint demand-responsive service, 71
  - computer technology, 97, 98
  - coordination, 54
  - labor, 142
  - operations systems, 91
  - ride-sharing, 70, 72
  - taxi as, 69, 72, 142
  - vehicle development, 8
- people movers, 45
- planning
  - computer software, 89
  - for elderly and handicapped, 94
  - for energy, 96
  - short-range, 96
  - in Transportation Systems Management, 94
  - manuals, 89
- productivity studies, 150

rail  
AC propulsion, 23  
accessibility to, 19  
automatic train control/operation, 27  
construction technology, 27  
construction management, 27  
electro-magnetic interference, 26  
elevated, 28  
energy conservation in, 26  
impact studies, 92  
maintenance, 17  
noise abatement, 20  
propulsion systems, 23  
safety and security, 134  
standardization, 17  
STARS, 23  
track and wayside, 29  
tunneling, 29  
wheel/rail dynamics, 22  
winterization, 24, 47  
*See also* light rail transit

RUCUS, 115

Rural Transportation, 73

safety and security, 134  
fire safety, 30, 135, 137  
information, 136  
training, 135

Section 15, 122

Service and Methods, 53

service reliability, 67

SIMS (Service Inventory and Maintenance System), 116

special users. *See* elderly and handicapped

standardization, rail, 17

STARS, 23

taxicab, 8, 54, 69, 72, 91, 142

training, 89, 91, 113, 135, 146

Transit Research Information Center, 154

Transportation Systems Management (TSM), 94

tunneling technology, 29

University Research and Training Grants, 146

UMTA Abstracts, 154

UMTRIS, 123

Urban Mass Transportation Administration  
contract/grant procedures, 157  
correspondence with, 156

Urban Transportation Planning System (UTPS), 89

user-subsidy, 54

vanpools, 69





**USER ROUTING CODE:**

NTIS can label each item for routing within your organization. If you want this service put your routing code in the box marked USER ROUTING CODE (Limit eight characters).

**SHIP & BILL SERVICE:**

Prepayment helps to expedite your order and can be accomplished through the use of an NTIS Deposit Account, check, money order, or charge card account number • For "Ship and Bill," NTIS charges \$5 extra for each order (regardless of the number of items, \$5 extra for each NTISearch, • NTIS does not "Ship and Bill" for orders outside North America

**ORDERING MAGNETIC TAPE:**

(check mode)

9 track     800 BPI     1600 BPI     6250 BPI    (odd parity)

**ORDERING BY TITLE:**

If ordering without an NTIS order number (by title only) allow an additional two weeks

**TITLE #1**

Sponsor's Series #

Contract or Grant Number of Report

Date Published

Originator (Give specific laboratory, or division and location.)

Personal Author

Turn to other side Write "1" in the NTIS Order Number block and complete the rest of the line.

**TITLE #2**

Sponsor's Series #

Contract or Grant Number of Report

Date Published

Originator (Give specific laboratory, or division and location.)

Personal Author

Turn to other side Write "2" in the NTIS Order Number block and complete the rest of the line.

**TITLE #3**

Sponsor's Series #

Contract or Grant Number of Report

Date Published

Originator (Give specific laboratory, or division and location.)

Personal Author

Turn to other side Write "3" in the NTIS Order Number block and complete the rest of the line.

**TITLE #4**

Sponsor's Series #

Contract or Grant Number of Report

Date Published

Originator (Give specific laboratory, or division and location.)

Personal Author

Turn to other side Write "4" in the NTIS Order Number block and complete the rest of the line.

**TITLE #5**

Sponsor's Series #

Contract or Grant Number of Report

Date Published

Originator (Give specific laboratory, or division and location.)

Personal Author

Turn to other side Write "5" in the NTIS Order Number block and complete the rest of the line.





**USER ROUTING CODE:**

NTIS can label each item for routing within your organization. If you want this service put your routing code in the box marked USER ROUTING CODE (Limit eight characters)

**SHIP & BILL SERVICE:**

Prepayment helps to expedite your order and can be accomplished through the use of an NTIS Deposit Account, check money order, or charge card account number. • For "Ship and Bill," NTIS charges \$5 extra for each order (regardless of the number of items, \$5 extra for each NTISearch, • NTIS does not "Ship and Bill" for orders outside North America

**ORDERING MAGNETIC TAPE:**

(check mode)

9 track     800 BPI     1600 BPI     6250 BPI    ( odd parity )

**ORDERING BY TITLE:**

If ordering without an NTIS order number (by title only) allow an additional two weeks

**TITLE #1**

Sponsor's Series #

Contract or Grant Number of Report

Date Published

Originator (Give specific laboratory, or division and location)

Personal Author

Turn to other side. Write "1" in the NTIS Order Number block and complete the rest of the line

**TITLE #2**

Sponsor's Series #

Contract or Grant Number of Report

Date Published

Originator (Give specific laboratory, or division and location)

Personal Author

Turn to other side. Write "2" in the NTIS Order Number block and complete the rest of the line

**TITLE #3**

Sponsor's Series #

Contract or Grant Number of Report

Date Published

Originator (Give specific laboratory, or division and location)

Personal Author

Turn to other side. Write "3" in the NTIS Order Number block and complete the rest of the line

**TITLE #4**

Sponsor's Series #

Contract or Grant Number of Report

Date Published

Originator (Give specific laboratory, or division and location)

Personal Author

Turn to other side. Write "4" in the NTIS Order Number block and complete the rest of the line

**TITLE #5**

Sponsor's Series #

Contract or Grant Number of Report

Date Published

Originator (Give specific laboratory, or division and location)

Personal Author

Turn to other side. Write "5" in the NTIS Order Number block and complete the rest of the line



DOT LIBRARY



00399723

An UMTA Technical Assistance Report

Prepared by:

Office of Technology Sharing — Code 31  
U.S. DEPARTMENT OF TRANSPORTATION  
Transportation Systems Center  
Kendall Square  
Cambridge, MA 02142