

D
0
0
1
0
7
4
1
7
5
9



UC SOUTHERN REGIONAL LIBRARY FACILITY

ARCHITECTURAL
DRAWING



*Konell & Thomas Architects.
Cleveland, Ohio*

*WEST ELEVATION
House for Mr. H. W. Breckenridge
Amherst, N.Y.*

ARCHITECTURAL DRAWING

by

WOOSTER BARD FIELD

ARCHITECT

ASSISTANT PROFESSOR OF ENGINEERING DRAWING
THE OHIO STATE UNIVERSITY



WITH AN INTRODUCTION
AND ARTICLE ON LETTERING

by

THOMAS E. FRENCH

PROFESSOR OF ENGINEERING DRAWING
THE OHIO STATE UNIVERSITY

EIGHTH IMPRESSION



McGRAW-HILL BOOK COMPANY, INC.
NEW YORK AND LONDON
1922

COPYRIGHT, 1922, BY THE
MCGRAW-HILL BOOK COMPANY, INC.

PRINTED IN THE UNITED STATES OF AMERICA

THE MAPLE PRESS - YORK PA

*NA
2700
F452

PREFACE

An exhaustive treatment of the subject of Architectural Drawing presents so many ramifications that, to cover them fully, several volumes of text and many expensive plates are required. Almost without exception these books and portfolios each deal with but one phase of the subject and go into that at some length. For this reason the architectural student must have access to a rather voluminous library or else invest in a number of more or less expensive books. Even with such a library available, the average student is at a loss to know how to go about his studies, and where there is such an abundance of material to select from, finds it very difficult to proceed intelligently. For one who is under the direction of an instructor, this difficulty is not so pronounced, but the latter arrangement presents to him another problem. He is usually working in a class with a number of others all of whom need the material at the same time.

Both teaching and office experience have proved that there are certain classes of information which should be at the draftsman's elbow at all times. This is true whether he be a student or employed in an office.

An effort has been made in the preparation of this book, to provide for the student those things which are of fundamental importance in his initial study of the subject, together with a careful presentation of some of the more important points that are usually left for him to acquire during his office experience after he has left school.

The material, though prepared primarily for the architectural student, will be found invaluable to anyone who deals with architectural work. It will enable the artisan, in any of the building or allied trades, to read the drawings and take off the quantities of his work for estimation purposes. He can then execute the work, according to the plans and specifications, without being dependent upon another for the interpretation of the drawings.

The articles are taken up in the sequence in which the work naturally goes forward on the board. This is not usually the order of procedure in studying the subject, but seems to be the logical way of recording it, since it gives the reader a comprehensive and well-ordered idea of the entire process. For the beginner, a preliminary explanation is made of the method of Orthographic Projection and its application to architectural drawing. This is followed by a description of the drawing instruments, after which are given those geometric solutions most used by the architect. Preliminary sketches, Scale and Detail Drawings, and the Orders of Architecture are then taken up. Under the subject of Scale Drawings are given typical examples of drawings which represent buildings of different materials and methods of construction, to show the student how prominent architects have taken care of such conditions. Notes have been added calling attention to the particular points illustrated. In addition to the instruction in drawing, is an article on Lettering as applied to architectural work.

A suggested course of study has been added as a guide to the student. This is presented in such a way as to serve as an outline for either a simple or a comprehensive course. It gives the student a definite order of procedure but makes it optional with him as to the extent of his work in each department.

While the book deals primarily with architectural drawing, suggestions are made for further study into both architectural design and engineering.

DEC 14 1937

SC

Arch. Arts

DEC 14 1936

Scribner

PREFACE

The architectural and building terms will provide a working vocabulary and an acquaintance with building parts.

The drafting room data will prove useful in the preparation of drawings.

The size of the book and style of binding have been found by experience to be the most practicable for use on the drawing board.

The help and encouragement of those architects whose work so well illustrates the text, are greatly appreciated. The use of drawings for buildings which have actually been erected, lends to the book a feeling of realness which could not have been attained by drawings invented for the occasion. Appreciation is hereby expressed also to J. S. MacLean of Columbus, Ohio, for his practical criticism of the mill work details and especially to Professor Thos. E. French for his kindly interest and helpful suggestions and for his Introduction and Article on Lettering.

W. B. F.

COLUMBUS, OHIO,
June, 1922.

CONTENTS

	PAGE
INTRODUCTION.	I
ARTICLE I. GRAPHIC METHODS OF REPRESENTATION.	5
ARTICLE II. DRAWING INSTRUMENTS AND THEIR USE	9
ARTICLE III. GEOMETRIC METHODS.	11
ARTICLE IV. PRELIMINARY SKETCHES	16
Perspective.	21
Isometric	29
Oblique	31
Shades and Shadows	33
Rendering	43
ARTICLE V. SCALE DRAWINGS	46
ARTICLE VI. DETAIL DRAWINGS	85
ARTICLE VII. THE ORDERS OF ARCHITECTURE	105
ARTICLE VIII. THE ACANTHUS LEAF	125
ARTICLE IX. MOULDINGS	127
ARTICLE X. ARCHITECTURAL LETTERING.	131
OUTLINE OF STUDY.	143
REFERENCE BOOKS.	147
ARCHITECTURAL AND BUILDING TERMS	151
ALPHABETICAL INDEX.	157



INTRODUCTION

BY THOMAS E. FRENCH¹

Architecture is one of the fine arts, taking its place along with sculpture, painting and music. As an art it is creative, rather than representative and involves perhaps a greater diversity of skill and knowledge than do any of the others. To be successful in it as a profession there is required in the first place a certain degree of native talent, and second, an extensive and thorough technical training. The true architect has an inherent sense of beauty of form and color—an instinctive feeling of proportion and balance and symmetry and harmony. This natural equipment when coupled with historical knowledge and technical ability enables him to design buildings that are not only well adapted to their purpose, structurally economical and safe, but are expressive, satisfying, and pleasing to the eye.

The architect is essentially an artist, keen in appreciation as well as facile with the pencil, and with a strongly developed constructive imagination. He must be able to think in three dimensions, to visualize the appearance of a proposed piece of work and see the picture of it in his mind's eye as clearly as if it were standing erected before him. This imaginative ability is not concerned alone with the exterior effect, but extends through the interior. The architect walks through a building whose proposed plan lies before him on the table just as surely as he will walk through the actual structure later when it has been built. The plan to him is not simply a diagram showing the location and arrangement of rooms. He feels himself in the house, sees the vistas, the heights of the ceilings, the proportions of rooms, and the prospects from the windows. He visualizes the color scheme which he would propose, the furniture and fittings, then by sketches and drawings conveys his thoughts to client and contractor.

Architectural drawing is the graphic language by which the architect develops and records his ideas, and communicates his instructions to the builder. Taken as a whole it is a language with many varied forms of expression and is capable of numerous divisions and subdivisions.

One kind of classification might be based on the methods of execution, separating freehand sketches, made without ruling or measurement, from scale drawings, which are measured and drawn accurately with instruments.

Another classification would be in the distinction between drawings of the structure made as it would appear to the eye, or perspective drawing and drawings made to give the actual forms and sizes, or projection drawing.

The student in Architecture should be trained in freehand drawing. The pencil is the best all-around medium but he should know the technique of pen-and-ink, charcoal and water-color. Drawing from the antique, still-life and life are usually included in the work of an architectural school, but the student should supplement these courses by constant practice. He should form the habit of carrying a sketch-book and rule and making notes of all sorts of architectural details. This not only gives practice in sketching, but accumulates a collection of information and teaches him the habit of careful observation. He learns to keep his eyes open.

¹ Professor of Engineering Drawing, The Ohio State University, Columbus, O.

ARCHITECTURAL DRAWING

He must also be trained in accurate drawing with instruments, mechanical drawing, as distinguished from freehand drawing. This includes skill in the use of the drawing instruments, a knowledge of the draftsman's methods of laying out geometrical figures and problems and a thorough acquaintance with orthographic projection.

A great French architect, M. Viollet le Duc, once said, "The architect ought not only to possess a large acquaintance with descriptive geometry but also to be so familiar with perspective as to be able to draw a design or parts of a design in every aspect." This statement is as true today as when originally made more than sixty years ago. Descriptive geometry is the basis of orthographic projection and a subject of preeminent value for training the constructive imagination, in addition to its constant practical application on the drawing board. It is a fascinating study but might be found more or less difficult to read without the aid of an instructor.

Perspective drawing as used by the ordinary artist in representing an object before him, requires only the observation of a few simple phenomena and rules. As used by the architect it becomes a mathematical subject, "Conical Projection," since his problem is not that of sketching an existing building, but of making a drawing of the exterior or interior of a proposed structure as it will actually appear to the observer when it is built. He needs this knowledge and facility in drawing in perspective not alone to show his clients the appearance of the building but, more important, for his own use in studying masses and proportions. A roof or dome for example will present an entirely different effect when viewed from the ground than it does on the working drawing used in building it.

The architect thinks on paper, first in freehand sketches, made with a rapid sure stroke, in perspective or projection as the case requires, then with T-square and instruments. To his client he presents his ideas usually in the form of sketch plans and pictorial sketches, as these are more easily understood by the layman than are working drawings. They often have the suggestion of color added by water-color or crayon pencils.

To the builder and artisan however he conveys his ideas and instructions by working drawings, so called because they can be worked from accurately. These are drawings made to scale, on the principles of orthographic projection, and containing full dimensions and notes. They are accompanied by the specifications, a written description of the details of materials and workmanship required, the two together called the "Plans and Specifications" which form the basis of the contract between owner and contractor, the architect acting as the owner's representative and agent.

The real architect then supplements his drawings and specifications by personal supervision of the work as it progresses, not because the drawings are incomplete, but that the expression of individuality may not be lost by unimaginative practical workmen.

A distinction must be made between an architect and an architectural draftsman. The latter is one who, under the direction of the former, can express the architect's ideas graphically in such a way as to make them clear to the builder. Starting with the preliminary sketches as developed by the architect he is able to work up the plans, elevations and details into a finished set of drawings ready for the contractor. The architectural draftsman with added experience and opportunity may become an architect; at least it may be said that all architects begin as architectural draftsmen.

ARCHITECTURAL DRAWING

To be fully qualified for his work the architectural draftsman needs to have training and experience in a variety of subjects connected with drawing. These might be enumerated somewhat as follows:

1. He must be thoroughly familiar with the principles of Orthographic Projection. This would include the Relation of Views, Auxiliary Projections, Sections, Developed Views, Reflected Views, Intersections, etc.
2. He must know the Architectural Symbols, and the methods of representing various forms of construction.
3. He must be acquainted with the History of Architecture. This includes a thorough working knowledge of the Architectural Orders.
4. He must know the principles of pure and applied design.
5. He must know materials, their strengths, characteristics, limitations and treatment.
6. He must be so familiar with Lettering that he can execute it rapidly and artistically on drawings, and can apply it correctly and beautifully as design in stone or bronze.
7. He should have a working knowledge of Perspective Drawing, Shades and Shadows, and Rendering.

(The skilled use of Perspective and of making rendered drawings has become something of a specialist's work and in larger offices there is usually one man who is employed on this class of work alone.)

The student should be reminded that *architectural design and drafting are inseparable*. Architectural drawing is not simply a mechanical operation nor a subject to be learned separately. The subject of architectural composition and design has been well presented in numerous books, and has only incidental reference in the present work but it must be understood that *a knowledge of composition and style is essential to successful drafting*.

In this book the Author, working from a combined experience as a practicing architect and a teacher of drawing, has brought together those fundamental subjects in drawing that should be studied by the prospective architectural draftsman, putting them in such form that they may be at hand for ready reference as he works over his designs on the board. It is thus both a text- and a reference book. The beginner will find the course of study outlined on pages 143, 144 and 145 a useful guide in its use as a textbook. As indicated in the preface, the covering of the entire range of architectural drawing in one volume is not practically possible. The necessarily brief treatment of some of the subjects suggests the desirability of supplementing them by concurrent study. The draftsman already familiar with the elementary subjects will, it is believed, find the material as presented of much value in his practical work.

PICTORIAL DRAWINGS

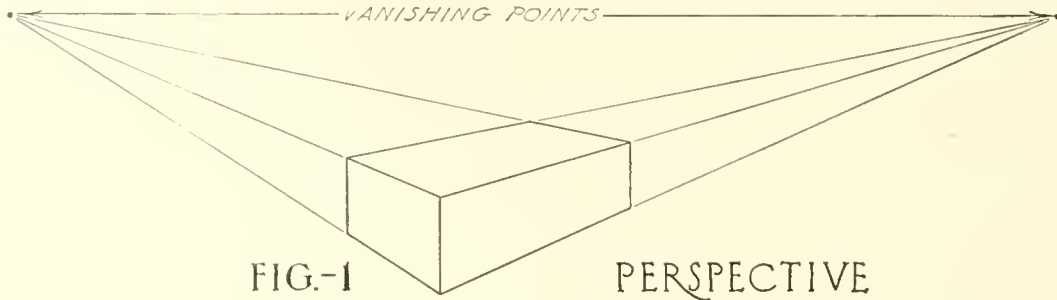

FIG.-1

PERSPECTIVE

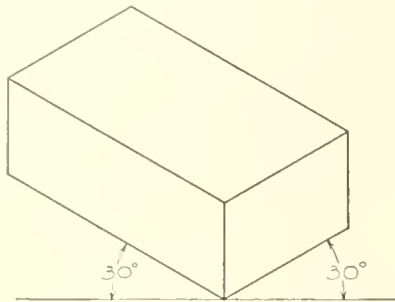

FIG.-2 ISOMETRIC

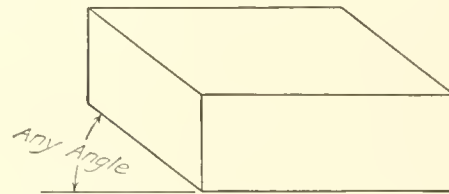
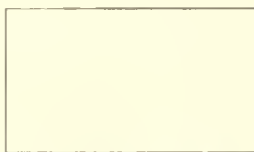

FIG.-3 OBLIQUE

ORTHOGRAPHIC PROJECTION DRAWINGS



TOP VIEW

These are but two of the several possible arrangements of the three views of the object. Notice that the top view is directly above and the side view directly opposite the front view.

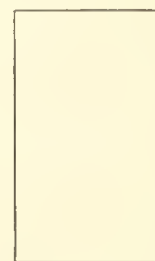

TOP VIEW

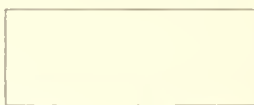

FRONT VIEW



RIGHT END

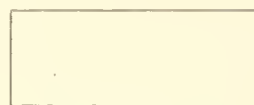

LEFT SIDE

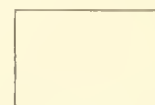

FRONT VIEW

FIGURE - 4

ARTICLE I

GRAPHIC METHODS OF REPRESENTATION

Plates 1 and 2

Before starting the architectural drawing proper, one must be familiar with the two general methods of representing an object having three dimensions (length, width and height) on the sheet of paper which has only two dimensions (length and width).

One method is by Pictorial Drawings or pictures and the other is by Orthographic Projection Drawings.

To illustrate by a simple object, a brick is represented in the two above mentioned ways.

There are three kinds of pictorial drawings in common use which will be treated of at length under other headings. Only their distinguishing characteristics will be pointed out here.

Figure 1 on **Plate 1** is a Perspective drawing of the brick in which it will be noticed that all except the vertical lines come together at what are known as vanishing points. The vertical lines on the brick are drawn vertically here. This is the way we actually see an object.

Figure 2 is an Isometric drawing of the brick, the characteristic of which is that all except the vertical lines of the brick are drawn toward the right or left at an angle of 30 degrees with the horizontal. The vertical lines are drawn vertically here as in the Perspective.

Figure 3 is an Oblique drawing of the same object. In this all vertical lines remain vertical as in the others. The lines running lengthwise of the brick remain horizontal and those running from front to back are drawn upward or downward at any desired angle, usually 30 or 45 degrees with the horizontal.

These pictorial drawings each show three sides of the object, but in each of them either the edges are foreshortened or else some sides do not show in their true shape. This is what makes it impracticable to work from pictorial drawings.

So as to avoid these distortions the method of Orthographic Projection is used in making working drawings.

An Orthographic Projection drawing of the brick would consist of one drawing representing what would be seen by looking straight at the front of the brick, one drawing as if looking straight down on top of the brick, and a third drawing as if looking straight at the end of the brick. These three drawings would be arranged on the paper as in Fig. 4.

If a drawing of the bottom is required it should be placed directly below the front view, etc.

It will be seen now that the Orthographic Projection drawings show the true shape of the faces and the true length of the edges.

METHODS OF REPRESENTATION

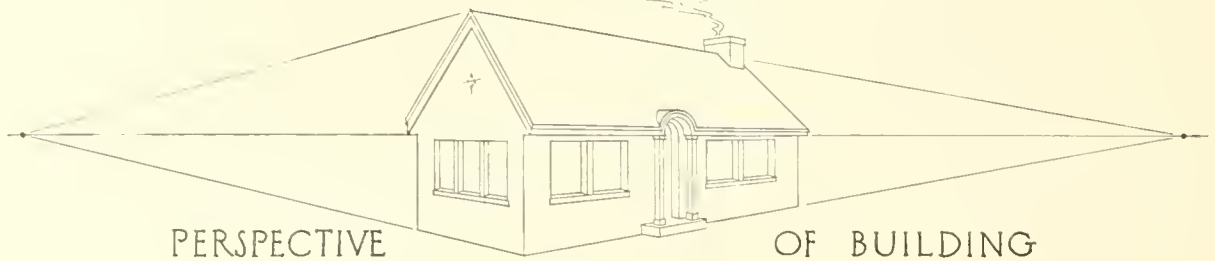

PERSPECTIVE OF BUILDING

FIG.-5

ORTHOGRAPHIC
PROJECTION
DRAWINGS

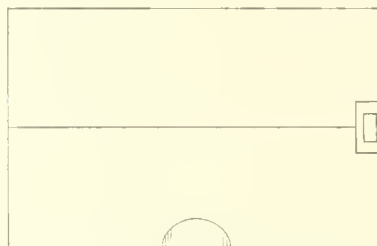

OF
THE
EXTERIOR

FIG.-8 ROOF PLAN

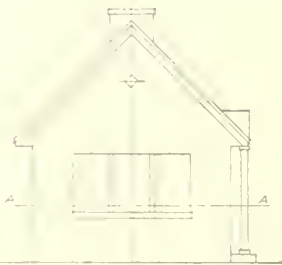

FIG.-7 LEFT SIDE ELEV.

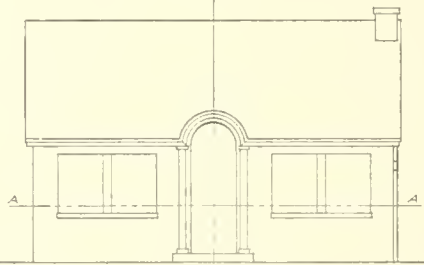

FIG.-6 FRONT ELEVATION

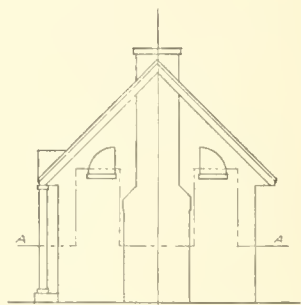
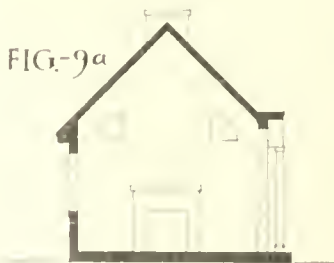

FIG.-7a RIGHT SIDE ELEV.

ORTHOGRAPHIC PROJECTION DRAWINGS
OF THE INTERIOR



CROSS SECTION



FLOOR PLAN

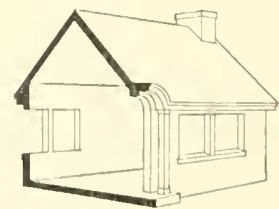

FIG.-9

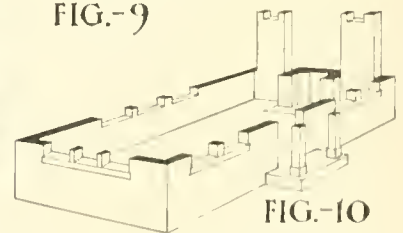

FIG.-10

PICTORIAL SECT. & PLAN

ARCHITECTURAL DRAWING

The architectural draftsman must be familiar with this method of representation as all working drawings are made in this way. For those who are not fairly well acquainted with it, a study of the subject will be of value at this time.¹

A building is represented in much the same way as the simple brick. A Perspective drawing of a simple building is given in Fig. 5, **Plate 2**. To show it in orthographic projection, a drawing would be made as though the observer were looking straight at the front as in Fig. 6; then as though looking straight at the side in Fig. 7 or 7a, and when looking straight down on top of it as in Fig. 8. The first three would be called "Elevations" and the last a "Roof Plan."

It should be noticed that the right side of the building, Fig. 7a, is drawn to the right of the front view. The left side, Fig. 7, is drawn to the left of the front view, etc.

If we imagine the building to be cut through parallel to the ground and the upper part removed as in Fig. 10, and then draw what is seen when looking straight down on the remaining part, we shall have what is called a "Floor Plan;" see Fig. 10a. It will be noticed that this horizontal section or Plan is taken at varying distances from the ground, when necessary, so that it may go through the features of the building which are to be shown on the Plan. This imaginary horizontal cut is taken along line *A-A* as shown by Figs. 6, 7 and 7a. Compare these with Figs. 10 and 10a.

If desired, a vertical section may be cut through from the front to the back of the house, one part removed, and the remaining part drawn as in Figs. 9 and 9a. This section may be taken at various places the same as the plan.

Plans, Elevations and Sections are the three devices which the architect employs to represent a building in orthographic projection.

The student should get this idea clearly in mind before proceeding with the work. A glance through the book just now will help him to see what Plans, Elevations, and Sections really look like. Notice for example the drawings of the Rae Cochran house on **Plates 21 to 30**.

¹ Consult list of Reference Books, page 147.

INSTRUMENTS

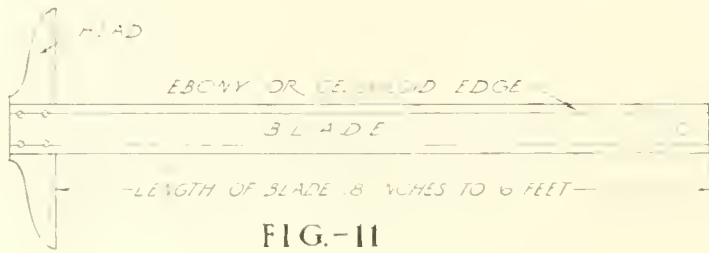

FIG.-11

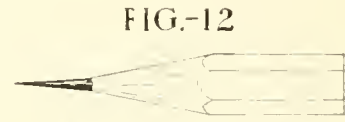

FIG.-12

FULL SIZE OF PENCIL POINT

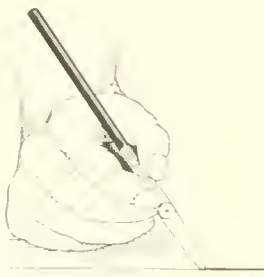

FIG.-14



FIG.-15



FIG.-13

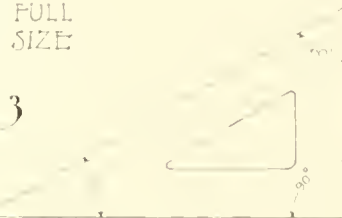

FIG.-16



FIG.-17



FIG.-19



FIG.-20

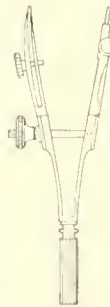

FIG.-21



FIG.-22

FIG.-23



FIG.-24

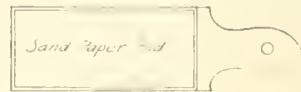

FIG.-18

FIG.-25



FIG.-26



FIG.-27

FULL SIZE

ARTICLE II

DRAWING INSTRUMENTS AND THEIR USE

Plate 3

Brief mention will be made here concerning the drawing instruments and their use.¹

Pencil.—The pencil is of course the draftsman's most useful instrument. Without a pencil of the proper grade, and in good condition, a draftsman can not hope to produce a good drawing. Select the pencil for the work in hand and sharpen it carefully. For sketching use a drawing pencil of grade F; for average drafting work and lettering use an HB or an H and for very accurate work where fine, sharp lines are necessary, a 2H or 4H will serve. The draftsman will soon become familiar with the different grades of hardness of leads and when to use them. Sharpen the pencil to a long tapering point as in Fig. 12, **Plate 3**, and keep the lead sharp by means of the sandpaper pencil pointer, Fig. 18. It is important that the point be kept sharp, as accurate work can not be done with a broad dull lead. By twirling the pencil between the fingers as a line is drawn, the point will be kept sharp longer than if it were held in one position as it is drawn along. This is an easy and valuable habit to acquire.

Drawing Board.—This should be a perfectly flat, smooth board of soft wood made in such a way that it can not warp or split. All edges should be perfectly true and smooth. A board 24 by 30 inches is a good size for the student although a smaller one may be used at first.

T-square.—The T-square, as shown in Fig. 11, is used for ruling horizontal lines only. The head must be held tightly against the left edge of the board thereby keeping the blade in a horizontal position. As the head is slid up or down along the board all positions of the blade will be parallel. Rule against the upper edge of the blade only, and from the left toward the right. A 30-inch blade will work well with the 24 by 30 inch board.

Triangles.—Two triangles will be needed, a 45-degree triangle as shown in Fig. 15 and a 30-60 degree triangle as in Fig. 16. The first is used in conjunction with the T-square to draw 45-degree and vertical lines. The other is for drawing lines at 30 degrees or 60 degrees with the horizontal or vertical. It too may be used to draw vertical lines. Always draw vertical lines from the bottom toward the top of the paper. It will be found that, with these two triangles, one may draw lines 15 degrees apart in any direction.

French Curve.—An irregular or "French" curve, as shown in Fig. 19, is needed for ruling curved lines other than circle arcs.

Scale.—The architect's scale, which is shown full size in Fig. 27, is one of the most important of the instruments and the beginner will do well to understand it thoroughly before proceeding. As architectural drawings are of necessity much smaller than the objects which they represent, it is necessary to adopt a "short foot and inch" with which to do the measuring on the drawing. So the architect has a scale for this purpose. It is a strip of wood covered with celluloid usually and is divided accurately into spaces which represent feet; these in turn are divided into twelfths, each twelfth representing an inch. Thus one edge is marked off into spaces of $\frac{1}{8}$ inch each and each space is considered as being a foot. Then one of these spaces is divided up into twelve parts for the inches. This is called the scale of $\frac{1}{8}$ inch to 1 foot and is written $1\frac{1}{8}'' = 1' - 0''$. Notice that the mark (") represents inches and the mark (') represents feet. The scale shown in Fig. 27 is divided so that $\frac{1}{8}$, $\frac{1}{4}$, $\frac{1}{2}$ and 1 inch are equal to 1 foot.

If we are to draw a building which is 100 feet long by 50 feet high at the scale of $\frac{1}{8}$ inch equals 1 foot, our drawing would be actually $12\frac{1}{2}$ inches long and $6\frac{1}{4}$ inches high. The beginner will have a

¹ For a complete discussion consult Reference Books, page 147.

ARCHITECTURAL DRAWING

tendency to think of it in this way which is absolutely wrong and will be found very confusing. Think of each $\frac{1}{8}$ inch as being a small foot and use the scale accordingly. Even though the drawing is quite small, think of it as being 100 feet by 50 feet. This will require a mental effort at first but becomes very easy with practice.

In a similar manner the scale is divided so that $\frac{3}{4}$ inch, $1\frac{1}{2}$ inches, and 3 inches each represent 1 foot. Thus a drawing of any object, however large, may be made at a scale to fit the desired size of paper.

Dividers.—The dividers, Fig. 20, are used to step off equal distances or to divide a line or space into equal parts.

Compasses.—The compasses, Fig. 24, are used to draw circles and circle arcs. They should be held at the top between the thumb and fore finger and spun around between them as the circle is drawn. If held by the legs there is a tendency to pull them together or force them apart thus spoiling the circle. Care must be exercised so that the needle point may not be pressed deeply into the paper as this will result in inaccurate work. Keep the needle and lead of even length by adjusting them when necessary.

Ruling Pen.—This, Fig. 17, is used for ruling lines in ink and is held as shown in Fig 14. It is filled with ink by placing the quill of the drawing ink bottle between the nibs of the pen, when the ink will run between the nibs. The width of a line is determined by the adjusting screw on the pen. The pen should not be filled too full, as the ink is likely to drop out or run out quickly when passing across another inked line. Try the pen on the border of the plate before using it on the drawing. The compass pen is operated similarly. Always keep the nibs clean outside and never allow ink to dry between them, as this would rust the pen and clog it up.

Erasers.—For general erasing, a Faber Ruby eraser is very satisfactory as it may be used for both pencil and ink lines on paper or tracing cloth. The draftsman should have also a piece of Art Gum for cleaning off light lines or soiled places.

Thumb Tacks.—Use small thumb tacks, Fig. 13, for fastening the paper to the board; the large ones are more expensive and less satisfactory to use. Always press the tacks firmly down, as it is the head, rather than the pin, which holds the paper in place.

Paper.—The architect finds use for several kinds of paper in his work.

Detail paper is a heavy paper used for the drawing of building details. It may be had in sheets or in rolls. The rolls vary in width from 36 to 54 inches and usually contain from 10 to 50 yards. A 36-inch roll may be cut, without waste, into sheets 36 by 26, 26 by 18, 18 by 13, 13 by 9, or 9 by $6\frac{1}{2}$ inches.

Tracing paper is a thin, white, transparent paper for general use where one drawing is to be made over another. It is much cheaper than detail paper and is ideal for sketches and scale drawings. It comes in rolls 30 to 50 inches in width and in various lengths.

Water-color paper is used where water-color renderings are desired. There are several kinds of good water-color papers, the two in most common use being the Italian "Fabriano" and the English "Whatman" paper. These are finished in three qualities, hot pressed (smooth surface), cold pressed (medium surface), and rough. The hot pressed is best for fine line work, the cold pressed for average rendering, and the rough for water-color sketches or bold work. The sheet sizes vary from 13 by 17 to $35\frac{1}{2}$ by 56 inches. The Imperial or 22 by 30-inch size is probably best for student work.

Bristol board is a cardboard for use in pen, pencil, or water-color rendering. There are two surfaces, the smooth for pen and ink, and the medium for pencil and for water-color. The board is made in a number of sizes and weights.

Ink.—Drawing ink is a heavy "India Ink" especially prepared for this work. It comes in bottles with a quill in the cork for use in filling the pens.

Lettering Pens.—See the article on lettering.

ARTICLE III
GEOMETRIC METHODS

Plates 4 and 5

Only those geometric solutions which the draftsman will be most likely to need in his work are given here.¹

To divide a line $A-B$ into two equal parts, Fig. 28, Plate 4, set the compasses at a radius larger than one-half of the line and with first A and then B as a center, draw intersecting arcs lightly at C and D . Draw a light straight line from C to D . This will bisect $A-B$.

To divide a line $E-F$ into any number of equal parts, say seven, Fig. 29, draw a light line slanting in any convenient direction, such as $E-G$. Now lay the scale along $E-G$ and mark off seven equal parts using any convenient length as a unit, say seven-eighths, seven-quarters, seven-halves or seven inches. From the last mark, "7," draw a light line to F ; then from each mark on line $E-G$, draw lines parallel to $7-F$ and cutting line $E-F$. These last lines will divide line $E-F$ into seven equal parts.

To divide the space between two lines into any number of equal parts, say five, Fig. 30, lay the scale with the zero end on one line and swing the other end around until any multiple of five coincides with the other line. In the illustration $\frac{3}{8}$ inch has been chosen as the unit. Mark off the five units along the scale and through each mark draw a line parallel to the two given lines. These will divide the space equally into five parts. This method is very valuable in laying out stair steps, etc.

To draw a perpendicular to a given line at a given point, FIG. 31, lay either triangle with the hypotenuse along the given line as shown by the dotted lines and place the T-square blade against one side of it as indicated. Now hold the T-square firmly and turn the triangle around, keeping its square corner against the T-square blade, then slide it along the blade until the hypotenuse passes through the given point, when the required perpendicular may be drawn against the hypotenuse of the triangle.

To draw lines parallel to any given line $L-M$, Fig. 32, place the triangle against the line $L-M$ as shown and place the T-square blade against the triangle. Holding the T-square in this position, slide the triangle along to positions as shown by dotted lines and any number of lines may thus be drawn parallel to the original line $L-M$.

¹ If other problems are met, consult "Kidder," The Architects' and Builders' Pocket Book.

GEOMETRIC METHODS

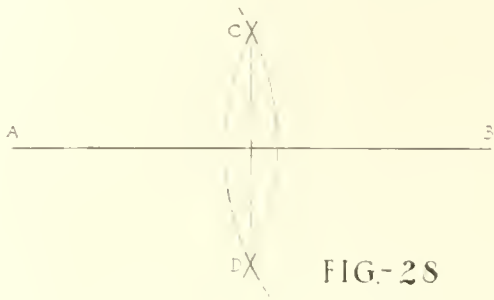

FIG-28

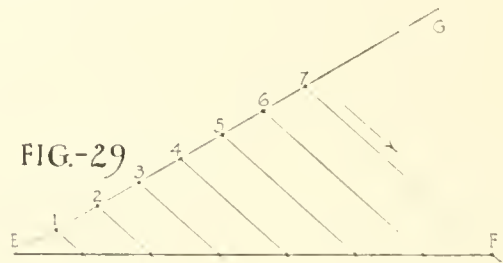

FIG-29

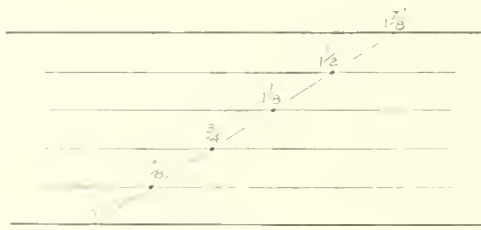

FIG-30

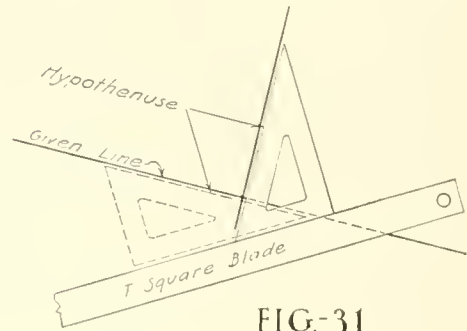

FIG-31

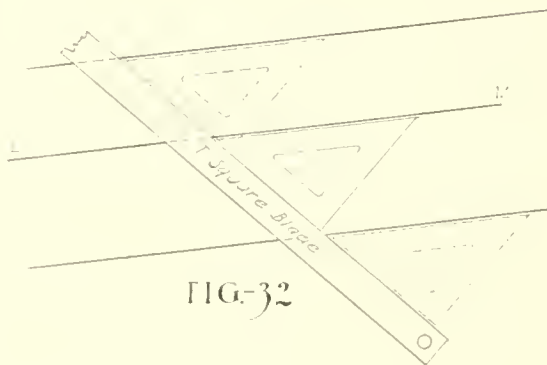

FIG-32

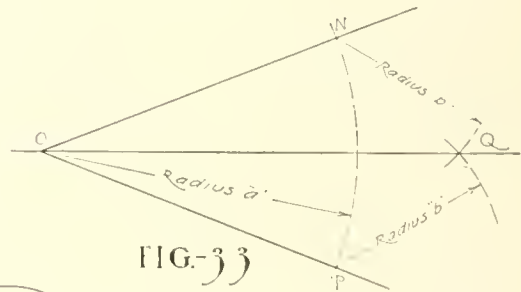

FIG-33



FIG-34

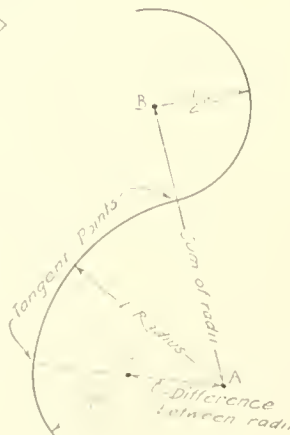

FIG-35

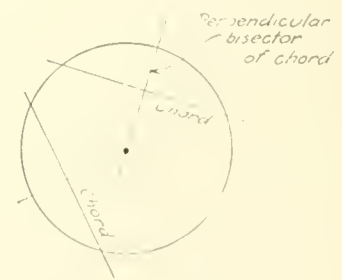

FIG-36

To bisect any angle N, O, P , Fig. 33, Plate 4, set the compass at any convenient radius " a " and with O as a center draw arcs at N and P lightly. With N and then P as centers and the same radius " b " from either center, draw the arcs intersecting at Q . Through O and Q draw the bisector.

To divide the circumference of a circle into six equal parts, Fig. 34, Plate 4, set the dividers equal to the radius and step off the parts directly, or use the 30-degree triangle as shown in the illustration.

To draw tangent circle arcs, Fig. 35, Plate 4. The point of tangency of two circle arcs is always on a line joining the centers of the two arcs, see lines $A-B$ and $A-C$. First locate the centers, then connect them by straight lines as indicated, then swing the circle arcs stopping each exactly at its tangent point. Notice that the distance between centers is equal to the sum or the difference of the radii of the circle arcs as the case may be.

To find the center for a given circle or circle arc, Fig. 36, Plate 4, draw any two chords and then draw their perpendicular bisectors by the method of Fig. 28. These bisectors will intersect at the required center if the work is carefully done.

To draw the arc of a circle when given the chord $A-B$ and the rise $C-D$ and when the center of the circle is not on the board, Fig. 37, Plate 5, first draw $E-F$ through D parallel to $A-B$; then draw $A-H$ and $B-K$ perpendicular to $A-B$. Draw $A-D$ and $D-B$ then draw $A-E$ perpendicular to $A-D$ and $B-F$ perpendicular to $D-B$. Now divide $A-H$, $B-K$, $E-D$, $D-F$, $A-C$ and $C-B$ into the same number of equal parts (in this case we have chosen six). Draw lines connecting the points as shown and draw the circle arc through their intersections.

To draw a true ellipse having the length of the major and minor axes given, Fig. 38, Plate 5, mark off on a strip of paper a length $A-B$ equal to one-half of the minor axis and $A-C$ equal to one-half of the major axis. Now move this "trammel," as it is called, into successive positions, always keeping point B on the major axis and point C on the minor axis. When in each of these positions, mark location of point A by a dot. After locating enough of these points, draw the ellipse through them with a French curve.

To draw a true ellipse by concentric circles, Fig. 39, Plate 5, draw first the major axis $D-E$ then the minor axis $F-G$ intersecting at center H . Then with H as a center draw a circle of radius $H-D$ and another of radius $H-F$. Divide these two circles into the same number of parts by drawing lightly the radial lines from H . From the intersections of each radial line with the circles, draw the short lines parallel to $D-E$ and $F-G$ as shown. Where these last lines intersect will be points on the ellipse. Notice that each radial line will fix two points on the ellipse. Locate as many points as accuracy demands.

To draw an approximate ellipse by the three center method, Fig. 40, Plate 5, lay off from the end of the major axis the distance $L-K$ equal to the radius chosen for the end of the ellipse. Locate N the same distance from M on the minor axis as K is from L and draw $K-N$. Draw the perpendicular bisector of $K-N$ until it intersects the minor axis at O . Draw a line through O and K to P . With K as a center

GEOMETRIC METHODS

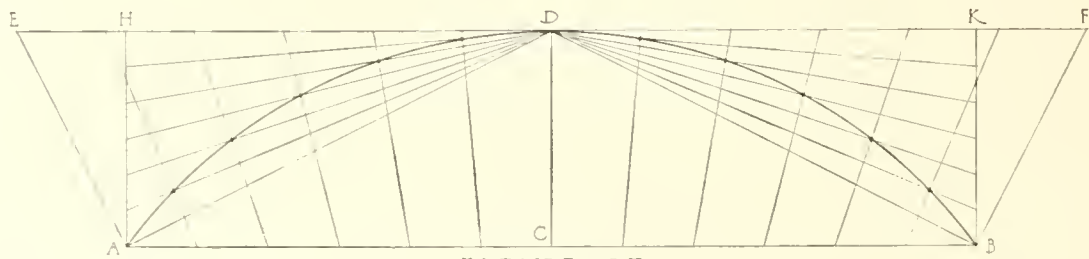

FIGURE-37

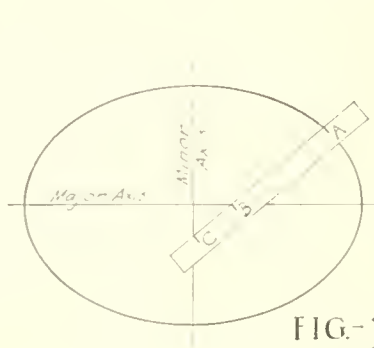

FIG-38

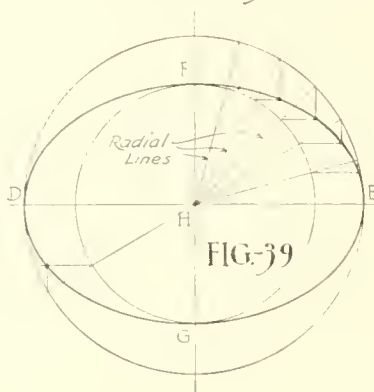

FIG-39

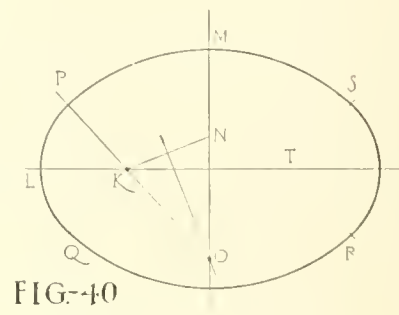

FIG-40

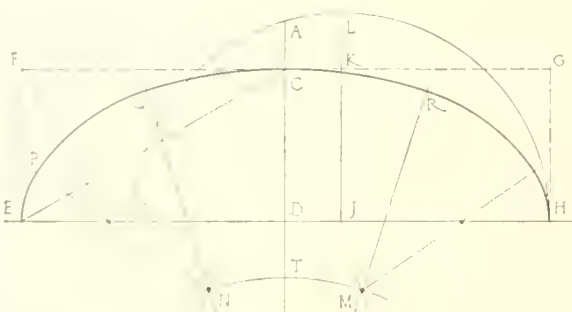

FIG-41

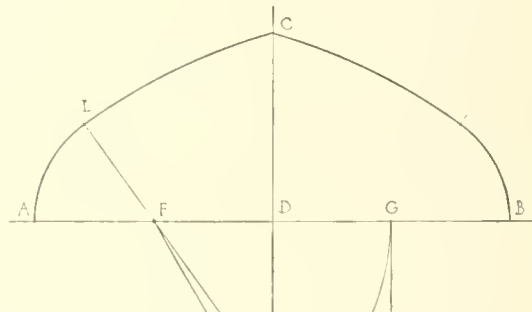

FIG-42

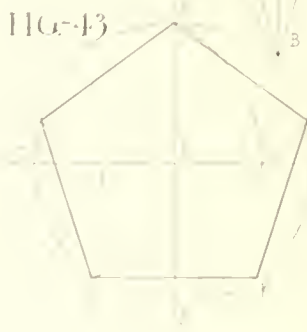

FIG-43

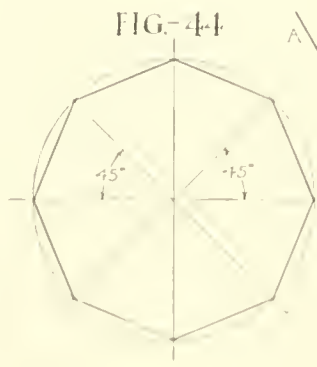

FIG-44

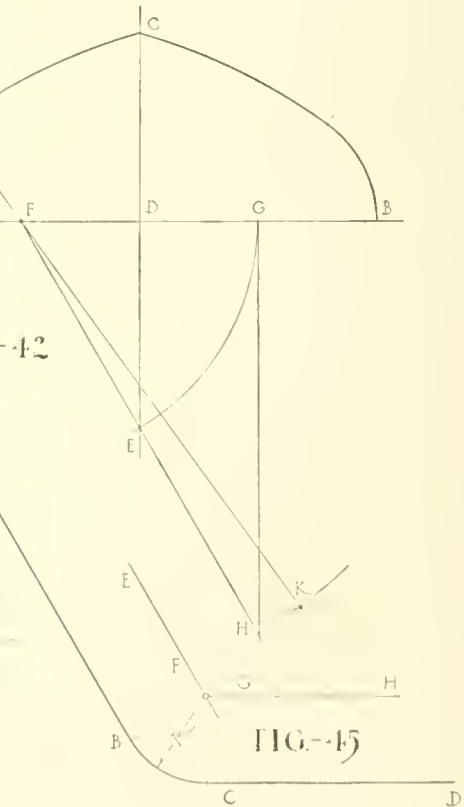

FIG-45

and radius $K-L$, draw the circle arc $Q-L-P$ forming the end of the ellipse. Then with O as a center and radius $O-P$, draw the circle arc $P-M-S$ forming the top of the ellipse. Complete the figure similarly. It will be found that by this method the ellipse will often be much distorted.

To draw an approximate semi-ellipse by the five center method, Fig. 41, **Plate 5**. Having drawn the major axis $E-H$ and the semi-minor axis $C-D$, complete the rectangle $E-F-G-H-E$. Draw $E-C$, and then $F-B$ perpendicular to $E-C$ and intersecting $E-H$ at O . Lay off $D-S$ equal to $D-C$ and with $S-H$ as a diameter draw the semi-circle $S-L-H$. Measure $D-T$ equal to $K-L$ then with B as a center and a radius $B-T$ describe an arc. With E and H as centers and a radius equal to $A-D$ describe intersecting arcs at N and M . Through these points and center B draw lines $B-Q$ and $B-R$. With O as a center and radius $O-E$ draw arc $E-P$. Then with N as a center and radius $N-P$ draw arc $P-Q$. Then with B as a center and radius $B-Q$ draw arc $Q-C-R$. Complete the ellipse similarly.

To draw a Tudor or pointed arch, Fig. 42, **Plate 5**, lay off the desired width or span $A-B$ and the height or rise $C-D$. Select any desired radius for the small circle arc, say $A-F$ and locate F and G . With F as a center and radius $F-G$ swing an arc cutting the center line at E . Draw line $F-E$ produced to meet a vertical line dropped from point G to locate H . With F as a center and radius $F-H$ describe an arc; then with C as a center and a radius equal to $A-F$ plus $F-H$, describe the small intersecting arc which locates point K . Draw line $K-F$ produced through L . Now with F as a center and radius $A-F$ draw arc $A-L$, then with K as a center and radius $K-L$ draw the arc $L-C$. Complete the arch similarly. This method produces the best arch when the radius of the smaller arc is equal to about one-fourth of the span but will work for other radii.

To draw a regular pentagon when given the distance from the center to a point, Fig. 43, **Plate 5**, draw the vertical and horizontal axes $A-B$ and $C-D$ intersecting at center E and draw the circumscribing circle. Then locate F , the middle point of $C-E$ and with this as a center and a radius $F-A$, describe an arc cutting $C-D$ at G . Then with A as a center and a radius $A-G$, swing the arc which locates point H on one side of the circle and point I on the other side. Then with H and I as centers and radius $A-H$, locate J and K . Connect $A-H-K-J-I-A$ to form the pentagon.

To draw a regular hexagon proceed according to the method given on **Plate 4** for dividing the circle into six equal parts. Connect the points on the circle using the 30-60 degree triangle.

To draw a regular octagon, Fig. 44, **Plate 5**, first draw the circumscribing circle with a diameter equal to the distance across points of the octagon. Draw the vertical and horizontal diameters and two others at 45 degrees with these. Connect the points where these lines cut the circumference of the circle.

To draw a circular intersection between two straight lines $A-B$ and $C-D$, Fig. 45, **Plate 5**, draw $E-F$ parallel to $A-B$ and at a distance from $A-B$ equal to the radius R of the connecting arc; then draw $G-H$ similarly. Where these two lines intersect will be the center for the circle arc.

ARTICLE IV

PRELIMINARY SKETCHES

Plates 6 to 18

The drawings which the architect first produces for his client are called preliminary sketches. They are the product of his preliminary study of the problem and serve as a basis for further study by both parties. The preliminary sketches consist of the principal plans accompanied by either the elevations or a perspective of the exterior. They sometimes include sections through the building to show parts of the interior. See **Plate 2**. These drawings are usually done in a sketchy manner but show clearly the general scheme.

They are made at a scale of $\frac{1}{8}$, $\frac{1}{16}$ or $\frac{1}{32}$ inch equal to 1 foot and sometimes not to any scale at all, in which case only the proportions are watched.

The plan of the building is the first preliminary to be worked out. The walls are usually represented in this drawing simply by single lines, allowance being made of course for the wall thickness when rooms are dimensioned on the sketch. While developing the plan, the elevation should be kept in mind to bring about the desired result. The client usually furnishes the architect with a general idea of the style of elevation he wishes and sometimes with the general arrangement of the plan.

The elevations are sketched rather roughly at first until an approximate scheme has been developed. Windows are often indicated here just by dark spots of the desired proportions; cornices and mouldings are indicated by drawing the shadows which they cast, etc. See **Plate 6**. Most designers work the plan and elevations along together until a satisfactory result is attained.

After this stage is reached, a pictorial drawing of the exterior is sometimes made, usually in perspective. This is then rendered by casting the shadows and often by showing the natural colors of the material in the building and its surroundings. The picture is made because it is usually difficult for the client to understand a direct elevation, whereas the picture is easily legible. If these preliminary sketches are to be submitted in competition with the work of other architects, as is frequently the case with sketches of public buildings, the rendering becomes a very important part of the work and is often done by artists who make this their profession.

To go about the preparation of preliminary sketches intelligently, the designer must know the amount of money to be spent and must become acquainted with the needs and preferences of his client. For example, in case of a residence, this means a knowledge of the members of the family to be housed and, to an extent, the likes, dislikes and needs of each. Then the general manner of living, the number of servants, the amount of entertaining done, etc., will all have a bearing on the design. A house to suit this family must also be made to fit the site or location. This means that the designer must become familiar with the site and its surroundings. If the house is to be built on very uneven ground, a survey should first be made by a competent surveyor.

Due regard must be given to the orientation or facing of the various rooms of the house.

The living room is the principal room of the house and as such it should be given special consideration. Plan it with a south and west exposure whenever possible, but of course the view from the windows will have a bearing on this. The outlook should be pleasant and, if it is not, a shrubbery screen may be planted to hide the objectionable feature from sight. A generous fireplace seems indispensable in this room. Place it where the most people can gather round it, not in a corner or where there will be a cross-draft through the room.

The dining room should look to the south and over a garden, lawn or other pleasant feature if possible. It should get the morning sun and should be bright and cheerful.

ARCHITECTURAL DRAWING

Kitchen at
Scored by

		TOTAL	CUT	SCORE
I	PLAN 35 POINTS			
	1 Arrangement of space for equipment..... Convenience of stove, table, sink, or other furniture.	15		
	2 Storage..... Storage pantry—size and convenience. Serving pantry—size and convenience. Refrigerator. Shelving and hooks adequate and convenient to sink. Stove. Table. Clock. Distances—if any two (stove, table, sink, pantry) are farther apart than 12 feet, cut ½ point for each foot more than 12 feet.	15		
	3 Doors..... If there are more than 4, cut one point for each. Outside door direct to covered porch or entry. If there is no covered porch, cut 1 point. Door to dining-room—double swinging if direct. Accessibility to front door. Accessibility to upstairs. Accessibility to cellar. If rear stair goes up from kitchen, cut 3 points.	5		
II	LIGHT AND VENTILATION 25 POINTS Should be two exposures; if only one cut 5 points. Glass area = 20% of floor area. Cut 1 point for each 1% under 20%. Window in pantry—cut 2 points if there is none. Satisfactory daylight at stove, sink, and table. Score 3 points for each if good. Transom over outside door, 1 point. If window stools are less than 34" from floor cut 1 point. Satisfactory artificial light at stove, sink, and table, 3 points each. Ventilating hood or flue, 1 point.	25		
III	FLOORS AND WALLS 10 POINTS			
	1 Floor—resilient and grease proof..... Hardwood, monolith, or linoleum are O. K. Cut for cracks, soft wood, carpet, etc.	4		
	2 Walls..... Light in color, cheerful and sanitary. Cut for violations of above requirements.	4		
	3 Woodwork..... Cut 1 point for dust-catching mouldings and projections. Cut 1 point for wood wainscot.	2		
IV	EQUIPMENT 30 POINTS			
	1 Stove—adequate size and condition..... If oven is less than 10" from floor, cut 1 point per inch. If there is no boiler, cut 2 points. If there is no thermometer, cut 1 point.	12		
	2 Sink..... Enamel or porcelain are O. K. Cut two points for uncomfortable height. Cut for iron, tin, etc., 3 points. Double drain-board; if single, cut 3 points. If splash board is wood, cut two points.	8		
	3 Table..... Size—Cut 1 point if smaller than 6 square feet. Height—Cut 1 point if uncomfortable.	3		
	4 Refrigerator..... Size, material, condition.	4		
	5 Fireless cooker.....	2		
	6 Chair and stool.....	1		
	Total.....	100		
	If no water in kitchen, cut 40 points. If no hot water in kitchen, cut 20 points. If kitchen is used as laundry, cut 15 points.			
	Remarks.....			
	Suggestions for improvement.....			

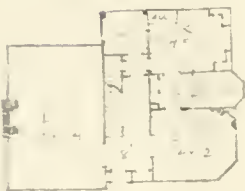

The kitchen is the work shop of the house and must be very carefully studied to be successful. It is best placed at the northeast corner of the house. The many points which demand attention in this room are suggested in the accompanying Kitchen Score Card, which is used in the Drawing Department at The Ohio State University. When planning a kitchen, the result should be checked carefully with this reminder.

The bed rooms should be well lighted and ventilated. Have windows in two walls whenever possible, to afford a cross circulation of air. Generous clothes closets are very much in demand.

In all rooms careful attention must be given to the providing of space for the furniture. To aid in this, the following approximate furniture dimensions are given.

Tables are about 29 inches high and the top of a dining table is about 42 to 48 inches wide by varying lengths.

Chair seats are about 18 inches square and 18 inches from the floor.

Rocking chairs are about 20 inches deep by 24 inches wide.

The kitchen stove projects from the wall about 26 inches and is 36 or more inches in width.

A grand piano is 6 by 5 feet. An upright piano is 5½ by 2½ feet.

A lounge or davenport is about 30 inches by 6 to 7 feet.

Double beds are about 5 feet wide, three-quarter beds are about 4½ feet wide and single beds 3 to 4 feet wide. Beds are about 6 feet 10 inches long.

Bureaus and chiffoniers extend about 18 inches from the wall and vary in width from 3 feet up.

For plumbing fixtures see **Plate 19**.

The preliminary sketch is decidedly the work of a designer and an original sketch can not be successfully produced without a knowledge of architectural composition and styles or an artistic sense of the fitness of things, both being necessary for the best results. The student, however, can at once learn how to make the necessary drawings and his ability as a designer will then be the result of constant study and development of his talents as he works along.

In developing a scheme it is always well, after a little thought, to get something down on paper and then to alter this until satisfied, rather than to attempt to think out the finished scheme in one's mind and then consider the first drawing made as being complete. The best results will be gained by putting down each step in the development as it is thought out. To facilitate this the designer makes use of transparent tracing paper. Thus sketch after sketch may be made one over the other for each alteration or addition, and in the end, a complete record of the development is preserved.

The current architectural magazines¹ furnish many suggestions for plans and elevations of various classes of buildings which may be followed by the student in his practice sketches.

On **Plate 76** is given a number of sketch plans and perspectives which may later be developed into working drawings by the student.

The Frontispiece is a preliminary sketch from the office of Howell and Thomas, Architects, of Cleveland, Ohio. It is in direct elevation and is a pencil sketch which has been lightly tinted with crayon, producing a pleasing effect. Notice that very few lines of the building have been drawn but rather the form of the parts is merely suggested in a sketchy manner by indicating shadows, etc. The surrounding trees, lawn and walks are sketched in perspective to give depth to the picture.

On **Plate 6** are some of the sketches from which was developed the design of the Cochran residence. The working drawings of this house are shown on **Plates 21 to 30**. The photograph on **Plate 6** shows the appearance of the completed house.

¹ A list of these magazines will be found on page 149.

PERSPECTIVE

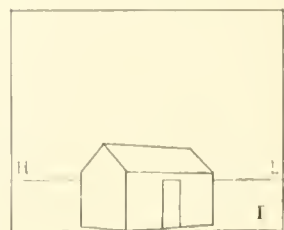
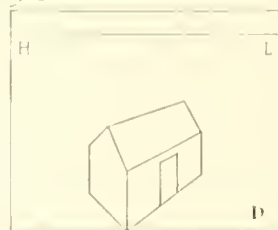
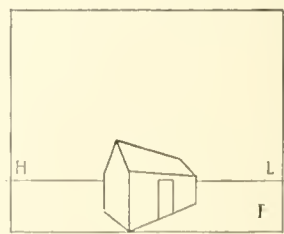
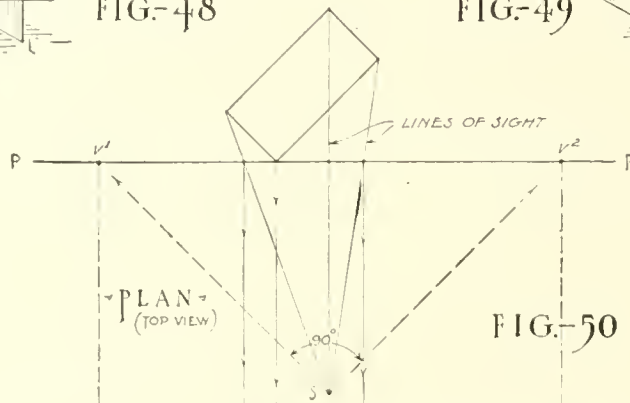
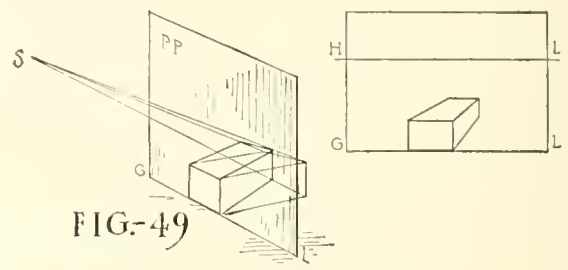
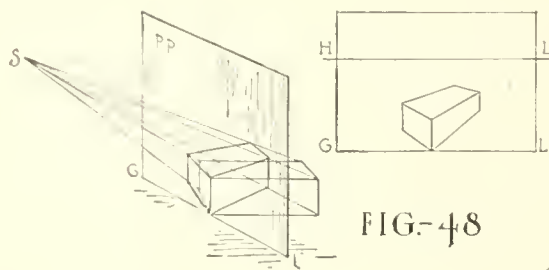
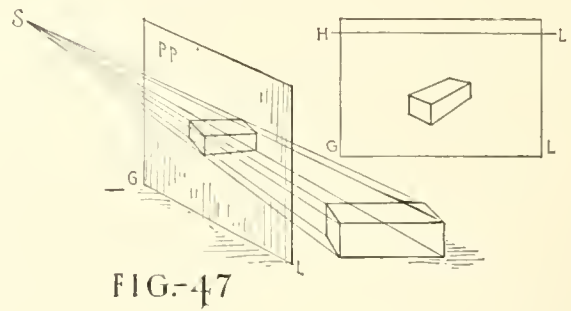
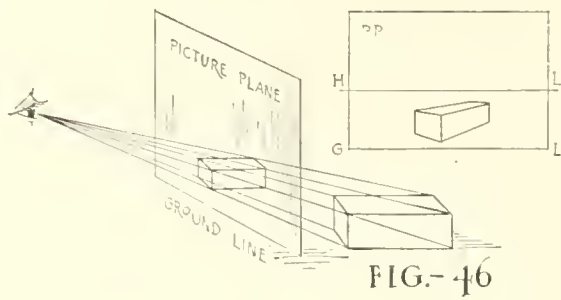

FIG.-51

VARIATIONS DUE TO DIFFERENT POSITIONS OF THE STATION POINT.

PERSPECTIVE DRAWING

Since the perspective drawing of an object shows it as it would appear to the eye of the observer, it is very important that the draftsman acquire the ability to draw and think in perspective.

As has already been stated he must express his design in a legible manner to his client and he must also be able to sketch quickly in perspective those features of his design which he can not readily visualize himself. As he gains a knowledge of drawing in perspective he will also acquire the ability to think in perspective which, to the designer, is an asset, the value of which can not be overestimated.

The decided difference between the appearance of the orthographic projection drawing of a building and the picture or perspective, may be seen by comparing the photograph of the Cochran house with the sketch of the front elevation on **Plate 6**. This is particularly true of roof lines and dormers.

An attempt has been made to keep the explanation as brief as possible and at the same time make it adequate for the needs of a student at this stage in his progress.¹

Theory and Notation.—The student must first become acquainted with the theory of perspective projection and the notation commonly used in developing these drawings. For example, consider a brick as being laid down on the ground at some distance from the eye and then imagine a glass plate to be set up vertically between the eye and the brick as in Fig. 46, **Plate 7**. This imaginary plate or plane will hereafter be referred to as the *picture plane* and marked *P-P* and its intersection with the ground will be called the *ground line* and marked *G-L*. The location of the eye of the observer is known as the *station point* and is marked *S*. The vertical lines of the object will be drawn vertically always. Any system of parallel lines on the object will meet at a point called the *vanishing point* and marked *V*. Parallel horizontal lines have their vanishing points on the horizon line. The horizon line is drawn horizontally, parallel to *G-L*. Its distance above the ground line is always the same as the distance that the eye is assumed to be above the ground.

Now imagine lines of sight to be drawn from the station point through the picture plane to the corners of the brick. Connect the points where these lines pierce the picture plane and the perspective projection of the brick on the picture plane will be the result.

It will be evident by a glance at Fig. 47 that if the eye (or station point) is elevated farther from the ground, the projection of the brick on the picture plane will also be raised; then too we can see from this new station point more of the top of the brick than before. The opposite is true when the eye is placed nearer to the ground. Notice that the projection on the picture plane is smaller than the brick, because the lines of sight converge as they go from the brick toward the picture plane. If we move the brick up until one edge is touching the picture plane as in Fig. 48, it is seen that the projection of that edge is in its true size, but that all of the brick behind the picture plane is projected smaller as before. From this we gather that measurements can be made only on the picture plane or where the picture plane and the object are in actual contact. In drawing the perspective of a building it is well to place the front corner against the picture plane so that the vertical distances may be measured along it.

¹If further study of the subject is desired, consult one of the handbooks listed on page 147.

PERSPECTIVE

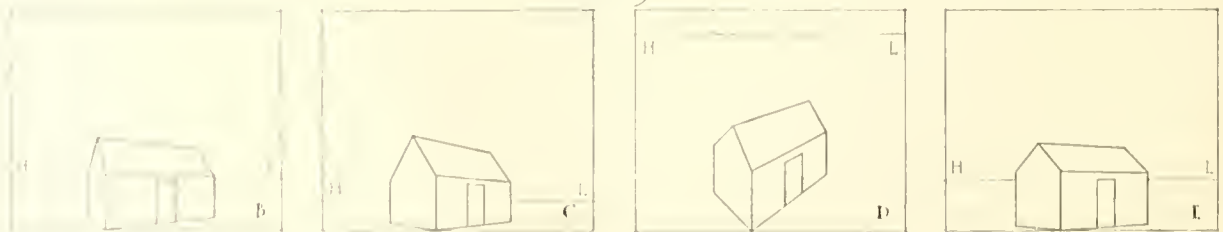
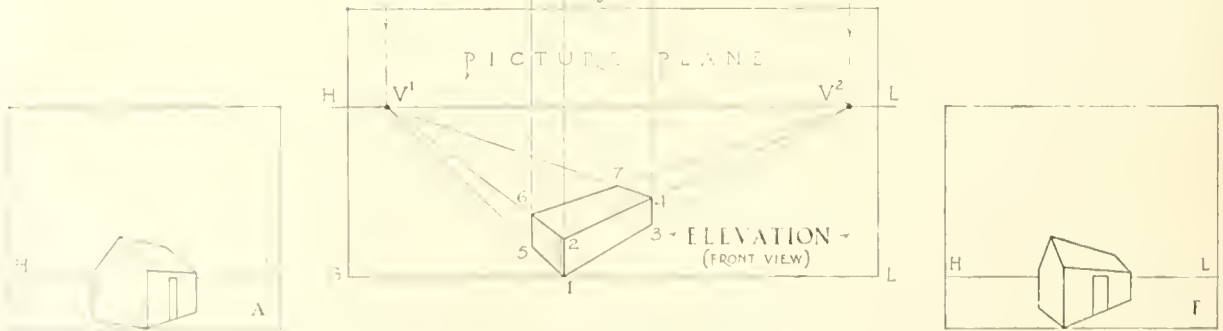
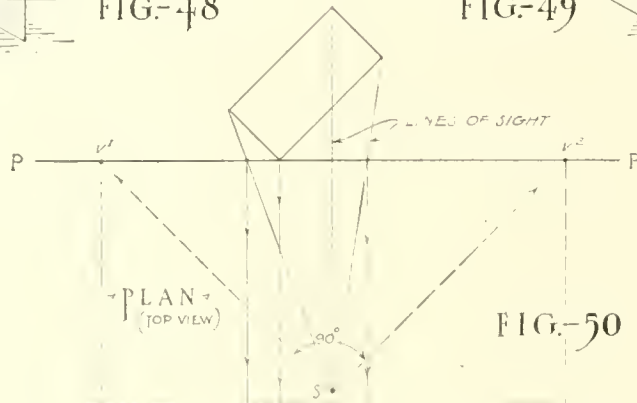
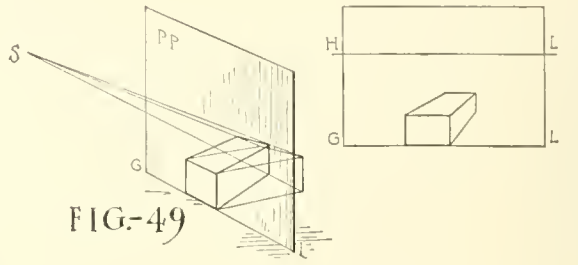
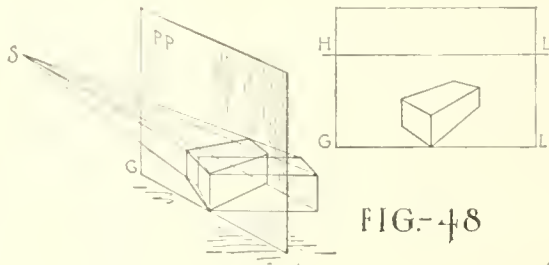
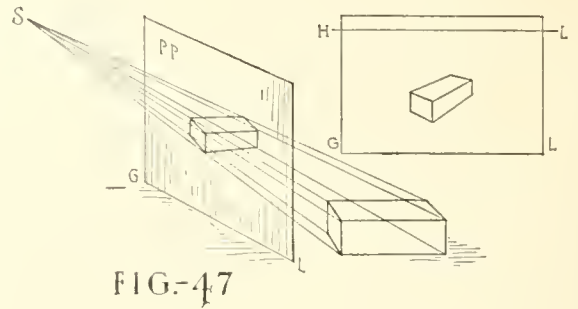
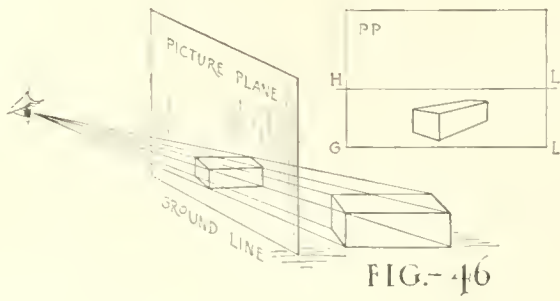

VARIATIONS DUE TO DIFFERENT POSITIONS OF THE STATION POINT.

Scale.—Perspective drawings are made to scale the same as orthographic projection drawings.

Systems.—Drawings will be in angular perspective when the object is placed at an angle with the picture plane as in Figs. 46, 47 and 48, **Plate 7**, and in parallel perspective when one face or edge is placed parallel to or else in the picture plane as in Fig. 49. The most pleasing presentation of a building is usually in angular perspective while the other method gives good results for interiors.

Study.—As a method of study it is suggested that the student follow carefully through the explanation of each figure, understanding fully every statement before proceeding to the next. After he has studied the operation and fixed each step in his mind he should draw the object in perspective to any convenient size.

Accuracy.—Since a slight error in draftsmanship would be likely to distort the result badly, great care must be exercised throughout the work. Keep the pencil needle-sharp and make all measurements and locate all intersections with the utmost exactness. After a little practice the student will learn where care is necessary and where it is not so important.

Angular Perspective.—Let the student imagine himself to be looking directly down upon the brick, picture plane and station point shown in Fig. 48 and draw at the desired scale what he sees as in the top view or Plan, Fig. 50, and below this, what he sees when looking straight toward the picture plane as in the front view or Elevation, Fig. 50. In drawing this front view first draw $G-L$ horizontally at a convenient place on the paper. Now if the eye is considered as being 5 feet above the ground, the $H-L$ should be drawn 5 feet above $G-L$ at the scale decided upon and parallel to $G-L$. The location of the eye or station point S must now be fixed at the desired distance in front of $P-P$ in plan and in the desired position laterally. This location must be carefully determined as the result depends largely upon it. Figure 51 shows several perspectives of the same building with the plan in the same position in each case but with S located in various positions. In Fig. 51A the station point is placed toward the left. It is toward the right in B, toward the center and low in C, high in D, at a distance from $P-P$ in E and very close to $P-P$ in F. By making a few quick sketches the position of the plan and station point may be quite accurately determined for the result desired. Thus the designer may imagine himself to be standing at any point about the building and, by drawing a perspective with this station point, he may learn exactly what his design will look like when viewed from this position.

From S , Fig. 50, draw a line parallel to one side of the brick intersecting $P-P$ at v^2 and one parallel to the end of the brick touching $P-P$ at v' . These two lines from S must always be 90 degrees apart no matter what the shape of the object may be. From v' and v^2 drop vertical lines to $H-L$ which will locate the vanishing points V^1 and V^2 of the two systems of parallel horizontal lines. Now draw the lines of sight from S in plan through $P-P$ to the corners of the brick. Where these lines of sight intersect $P-P$ drop light lines to the front view. Point 1 is in $G-L$ because it is on the ground and touching the picture plane. From point 1 draw a line toward V^2 . Measure up from point 1 a distance equal to the height of the brick, locating point 2 and from here draw toward V^2 ; then draw line 3-4. Similarly draw 1-5 2-6, and 4-7 toward V^1 ; then draw 5-6, then 6-7 toward V^2 and the perspective is complete.

PERSPECTIVE

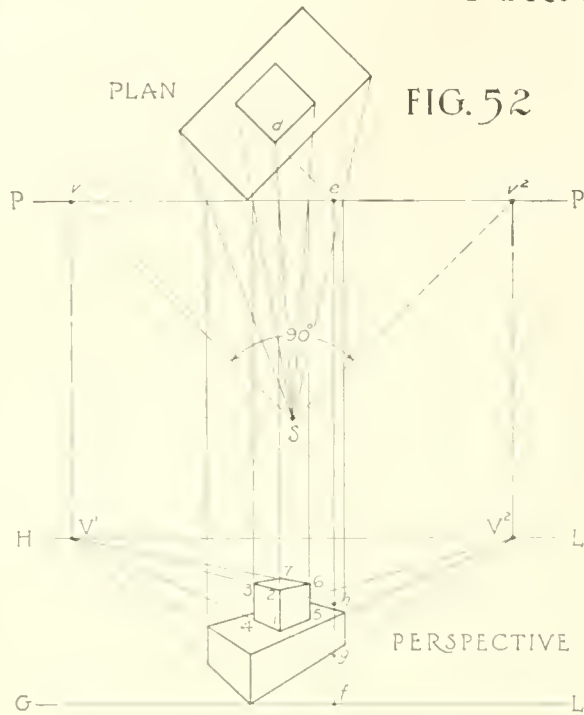

RECTANGULAR PRISMS
IN ANGULAR PERSPECTIVE

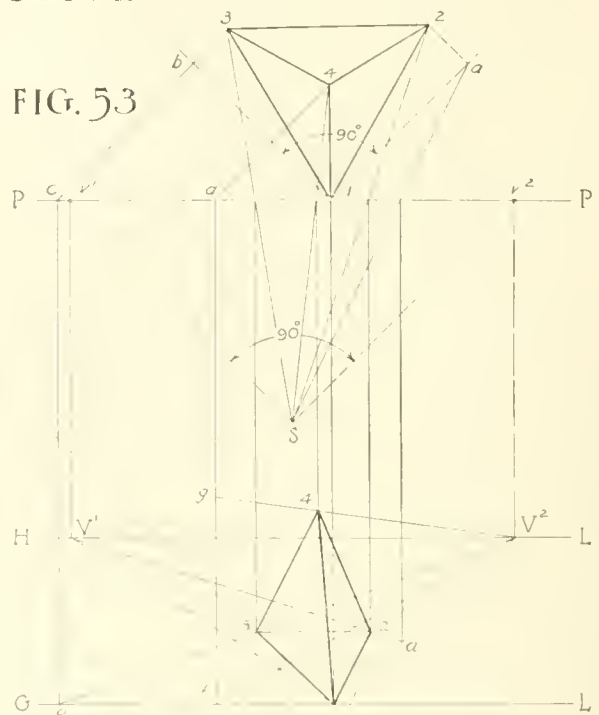

IRREGULAR OBJECT
IN ANGULAR PERSPECTIVE

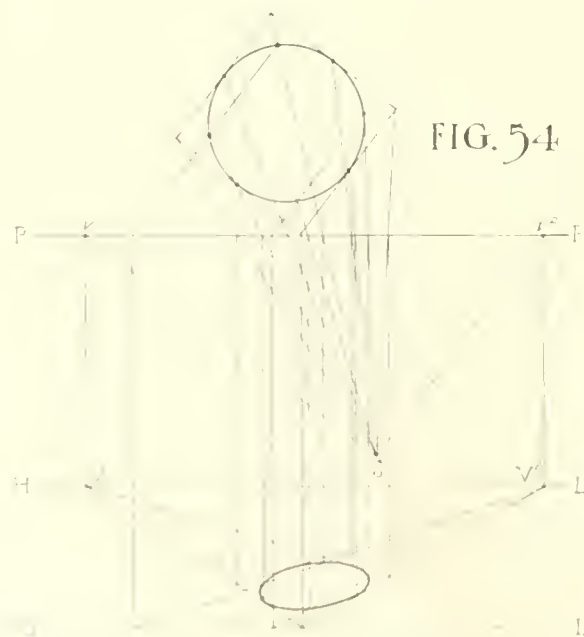

HORIZONTAL CIRCLE
IN ANGULAR PERSPECTIVE

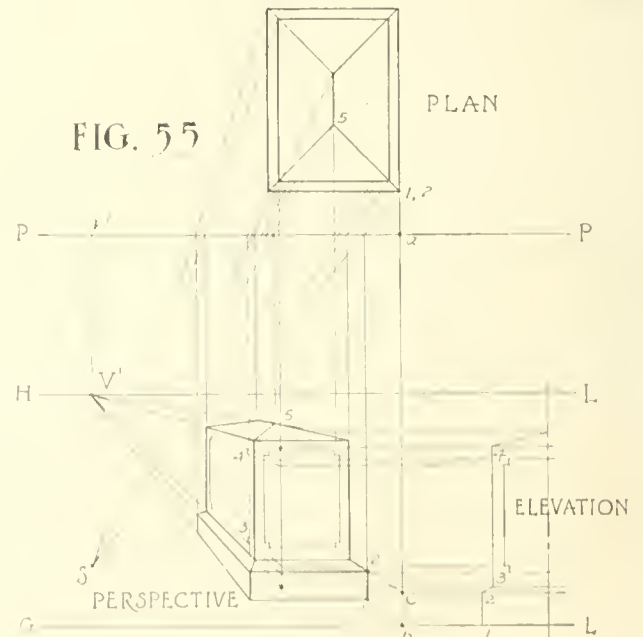

PARALLEL PERSPECTIVE
OF AN OBJECT WITH
RECTANGULAR & IRREGULAR PARTS

Objects not Touching the Picture Plane.—To the object shown in Fig. 50 is added a cubical block, Fig. 52, **Plate 8**, considering the cube to be the same height as the brick. Draw the sight lines from S to the plan of the cube and from their intersection with $P-P$ drop lines to the front view as before. As the cube does not touch the picture plane, we can not measure its height directly along any of these lines. One way of determining this height is to consider one vertical face of the cube as being brought forward to $P-P$ meeting it at e in plan. In a case like this, line $d-e$ must be brought down parallel to line $S-v^1$ or line $S-v^2$ in plan. Draw from e down to $G-L$ at f . Now line $e-f$ in elevation is in the picture plane and distances may be measured along it. From f measure up the height that point 1 is from the ground, marking it at g and from g measure up the height of the cube to h . Draw from g and h to V^1 which will give the perspective of face 1-2-3-4. Now draw 1-5, 2-6, and 3-7 toward V^2 and then 6-7 toward V^1 . Any part of an object back of the picture plane may be measured and drawn in this manner.

Irregular Objects.—A perspective of the triangular pyramid, Fig. 53, **Plate 8**, is made in much the same way as the prism of Fig. 52 with a few exceptions. Draw the plan, locate $P-P$ and S and then draw $G-L$ and $H-L$ in elevation. Draw the sight lines and drop light lines to the front view as before. Since the object is not rectangular in plan, the perspective may be worked out from the two lines 1- a and 1- b which are drawn at right angles with each other in plan. The direction of 1- a and 1- b will determine the effect of the drawing. Experience and trial will tell just what angle they should make with $P-P$ for the best result. Having drawn these two lines, draw $S-v^1$ and $S-v^2$ parallel to them and locate V^1 and V^2 as in Fig. 52. Now in plan draw a line parallel to 1- a through apex 4 of the pyramid intersecting $P-P$ at d and a similar line through corner 3 locating point c on $P-P$. Drop from c and d to $G-L$ at e and f then draw from e toward V^2 locating the perspective of corner 3. Corner 1 is of course on $G-L$. Draw 1- V^2 and 1- V^1 . Draw from the plan of 2 parallel to line 1- b , locating point a on line 1- a . Find the perspective of point a on the perspective line 1- V^2 and draw from here toward V^1 , locating the perspective of corner 2. Connect 1, 2 and 3 for the perspective of the base of the pyramid. Measure up from f to g , a distance equal to the height of the pyramid. Draw from g toward V^2 , locating the apex 4 in perspective. Connect 4 with 1, 2 and 3. Corner 2 might have been found in the same manner as corners 3 and 4.

Perspective of Circle.—A circle may be drawn in perspective, Fig. 54, **Plate 8**, by “boxing it in,” drawing the perspective of the “box” or square according to the method of Fig. 52 and then getting the perspective of a number of points on the circle by the method of locating point 3 in Fig. 53.

Parallel Perspective.—When the plan is drawn with one face of the object in or parallel to the picture plane as in Fig. 49, **Plate 7**, or Fig. 55, **Plate 8**, the drawing will be in parallel perspective. In this we have but one vanishing point and that is in what is known as the center of vision and is on the horizon line directly opposite the station point. In this figure the sight lines as drawn from S to the plan would cross the front view and so are omitted for a portion of their length. Notice that a part elevation is drawn to the right. By doing this the height of any part can be obtained by simply projecting from the elevation across to the perspective. Since the object here is not touching $P-P$ it is necessary to bring one or more corners forward to $P-P$ so that heights may be measured along them. The vertical edge 1-2 has been brought forward parallel to $S-v^1$ just as $d-e$ was brought to $P-P$ in Fig. 52. From point a on $P-P$ drop to $G-L$ at b . Project over from the elevation at the right and locate the height of the base $b-c$. Project from b and c toward V^1 to locate the perspective of edge 1-2. All edges at right angles to those whose perspective vanishes in V^1 will be drawn horizontally or parallel to $G-L$. Any isolated points such as point 5 may be located by the method of point 4 in Fig. 53. Locate 3-4 similar to 1-2, etc.

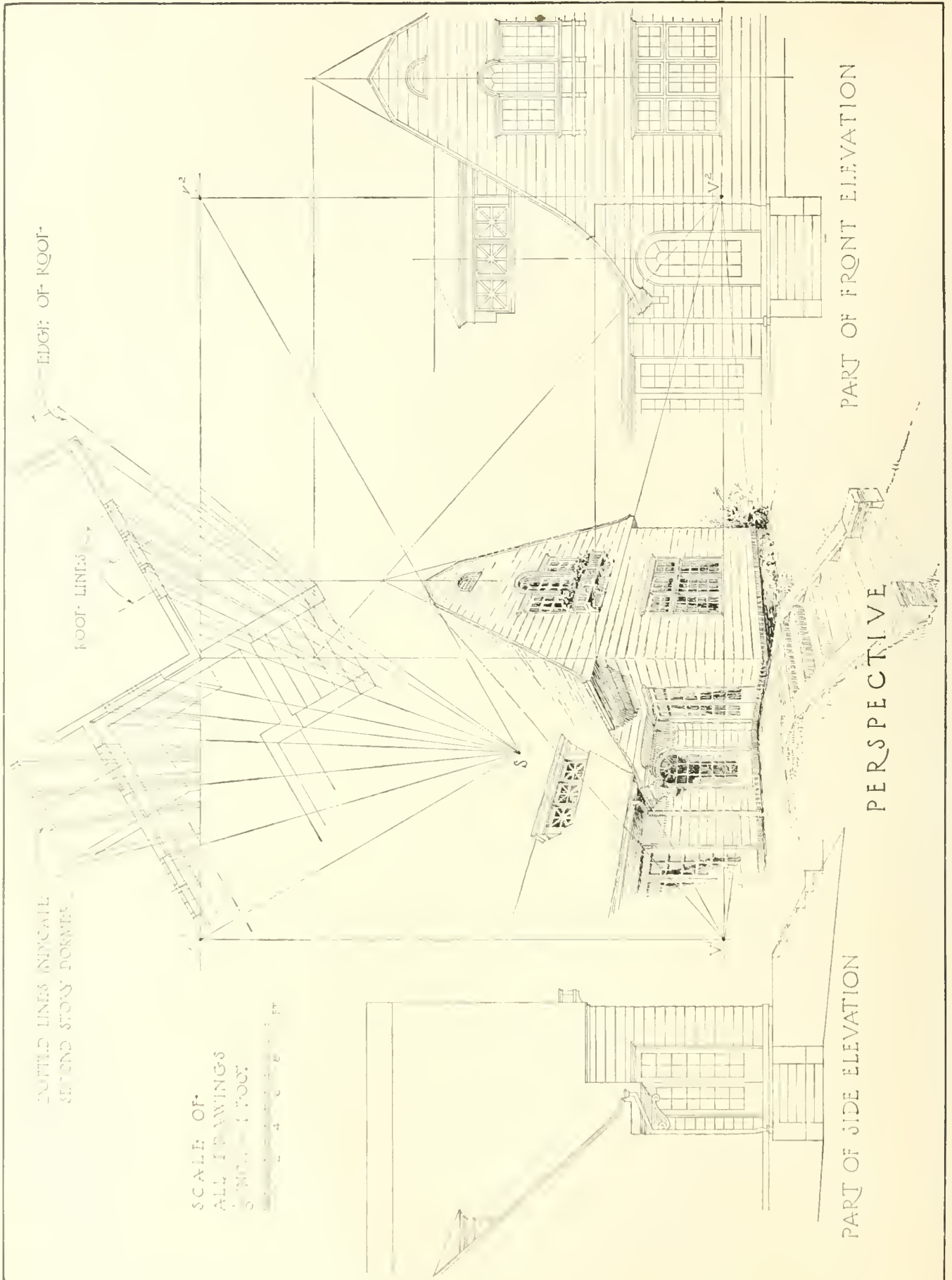

EDGE OF ROOF

ROOF LINES

DOTTED LINES INDICATE SECOND STORY CORNER

SCALE OF ALL DRAWINGS 3/8" = 1 FOOT

PART OF FRONT ELEVATION

PERSPECTIVE

PART OF SIDE ELEVATION

On **Plate 9** is a perspective drawing of a portion of the Cochran residence. Some of the construction lines are shown and only the methods of the previous plate have been employed in working it out. Notice that the station point has been taken about 6 feet above the ground and just to the left of the walk. This is the way the house would look if the observer were standing just below the terrace and looking toward the front door.

As a matter of interest, compare this mechanical perspective with the photograph given on **Plate 6**. Even though the station point of the camera was much farther away than that of the opposite drawing, and details of the house were altered somewhat in building, the parallel between the two pictures will be seen to be quite close.

The sketchy effect was obtained by first drawing the perspective mechanically with a soft, sharp pencil and then inking the lines freehand. Notice that the lines of the siding and shingles are not continuous but are just suggested, as are also the bricks of the base course, the muntins of windows, etc.

As an exercise in perspective the student might use first the simple Tuscan entablature of **Plate 63**, then one of the more complicated Orders and finally draw up a perspective of the residence described by **Plates 21 to 30** or some other rather simple building.

It is not always necessary that every little detail of a building be drawn in mechanical perspective. The main lines must of course be located accurately but the draftsman will soon be able to judge as to what should be accurately drawn and what may be drawn by eye.

ISOMETRIC

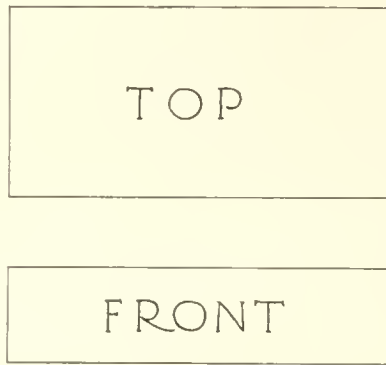

FIG. 56

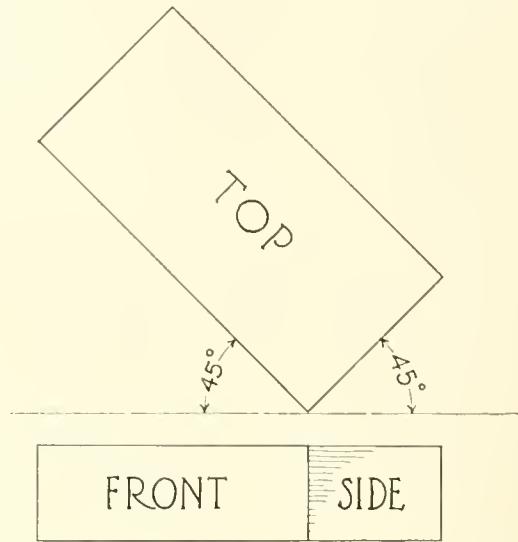

FIG. 57

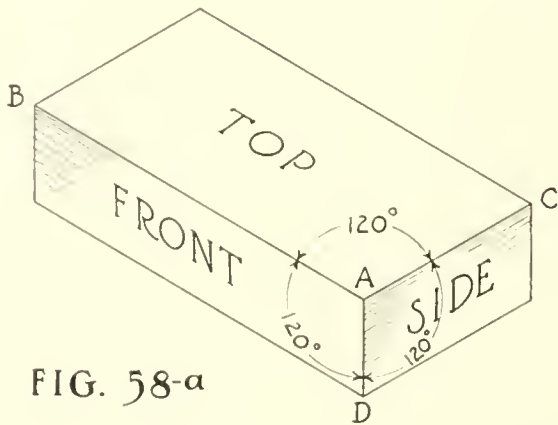

FIG. 58-a

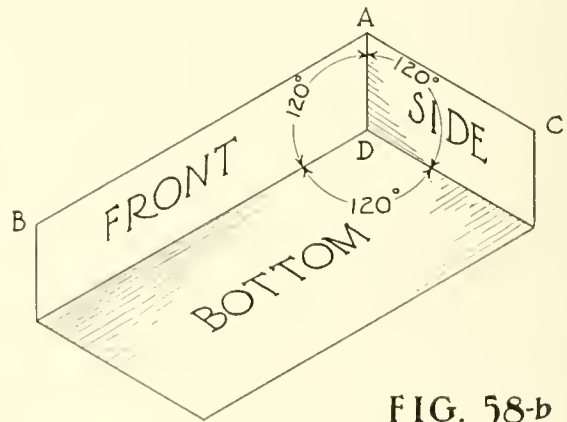

FIG. 58-b

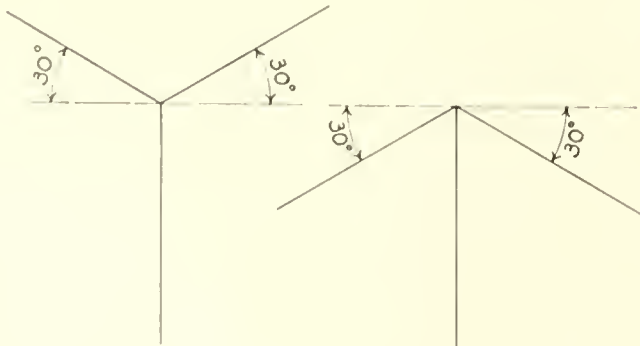

FIG. 59-a

FIG. 59-b

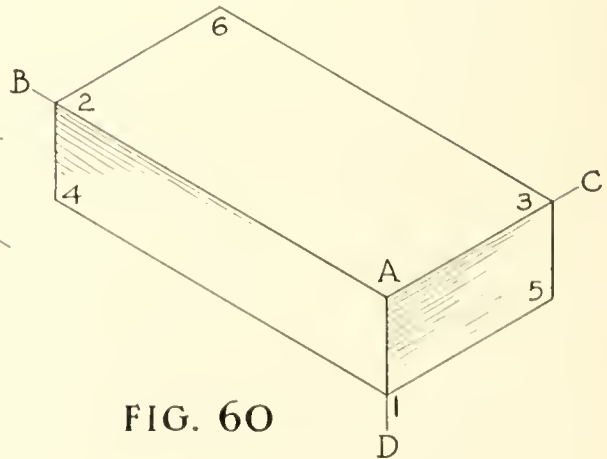

FIG. 60

ARCHITECTURAL DRAWING

ISOMETRIC DRAWING

While perspective projection is the method of pictorial representation generally used by the architectural draftsman, he sometimes finds it desirable to draw a quick mechanical picture on which he can measure most distances directly. This can not be done on a perspective as most of the distances are more or less distorted as has already been seen.

To supply this need of an easily made picture upon which parts may be measured directly, we have a system of drawing called Isometric Drawing. Although the ability to measure distances on this kind of a picture is gained, there is somewhat of a loss in pictorial value, as the Isometric drawing does not show the object exactly as seen by the eye of the observer.

This system then is used where approximate pictorial effect is desired together with the advantage of measuring distances directly on the picture. Such drawings are found useful to the architect in making pictorial diagrams of piping systems, etc., where artistic appearance is not a factor. In these the walls and floors are imagined to have been removed showing only the boilers, tanks, radiators, etc., with the connecting pipe lines all in the proper relation to each other. The usual Orthographic Projection drawing would be inadequate to show clearly and comprehensively such a system as a whole.

This pictorial method is seldom used to represent the building itself except that it is sometimes satisfactory for framing drawings. See **Plate 46**.

For an illustration of this method, the brick has again been used and is considered to be 8 inches long, 4 inches wide and 2 inches high, Fig. 56, **Plate 10**. First it is turned so that the 2 by 8-inch face and the 2 by 4-inch face make angles of 45 degrees with the picture plane, Fig. 57; then tilted up or down into either position shown in Fig. 58a or 58b so that edges $A-B$, $A-C$ and $A-D$ each make an angle of 120 degrees with the other. These lines are known as Isometric Axes and all lines parallel to them are Isometric Lines.

Of course edges $A-B$, $A-C$, etc., are foreshortened when the brick is turned into this position but since this distortion is not great, all isometric lines are drawn in their true length. Accurate measurements may be made only along or parallel to these isometric lines. Thus in Fig. 58a or 58b every visible edge of the object is shown in its true length just as in Fig. 56.

If $A-D$ is drawn vertically, $A-B$ and $A-C$ will make angles of 30 degrees with the horizontal, either up as in Fig. 59a or down as in Fig. 59b.

Now to represent the brick in isometric projection, Fig. 60, first draw the isometric axes like Fig. 59a (if it is desired to look down toward the top of the brick) or like Fig. 59b (if a view from below is needed); then in Fig. 60 measure along $A-D$ 2 inches to point 1, then along $A-B$ 8 inches to point 2 and along $A-C$ 4 inches to point 3. Draw lines 1-4 and 3-6 parallel to $A-B$ with the 30 degree triangle and T-square; then draw 1-5 and 2-6 parallel to $A-C$. Draw 3-5 and 2-4 vertically and the isometric drawing will be completed. This is the method of drawing any rectangular prism or combination of rectangular prisms.

ISOMETRIC AND OBLIQUE

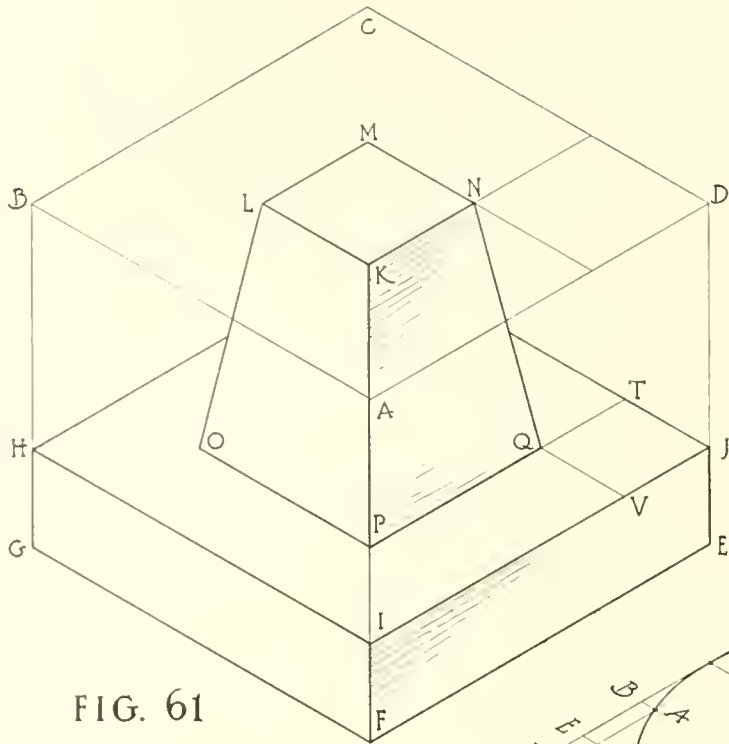

FIG. 61

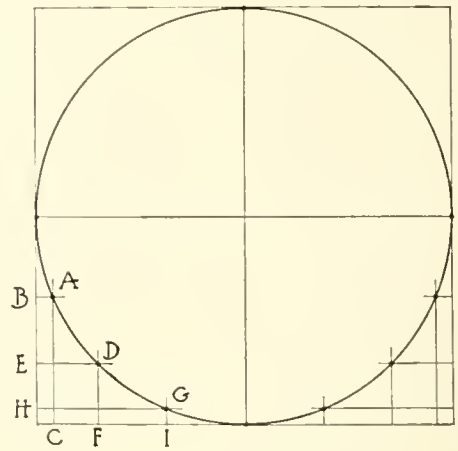

FIG. 62-a

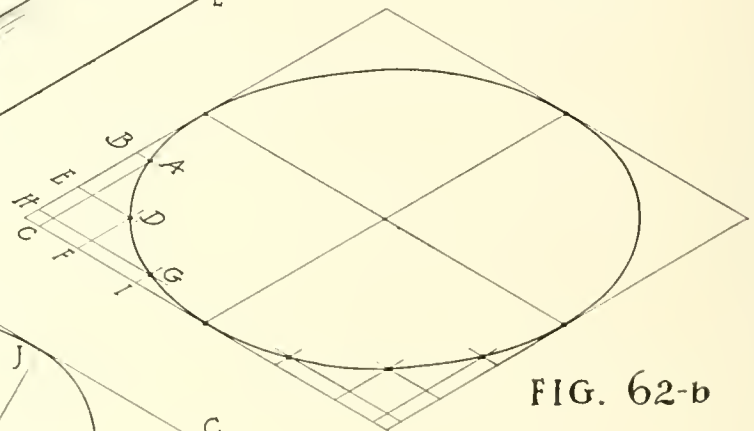

FIG. 62-b

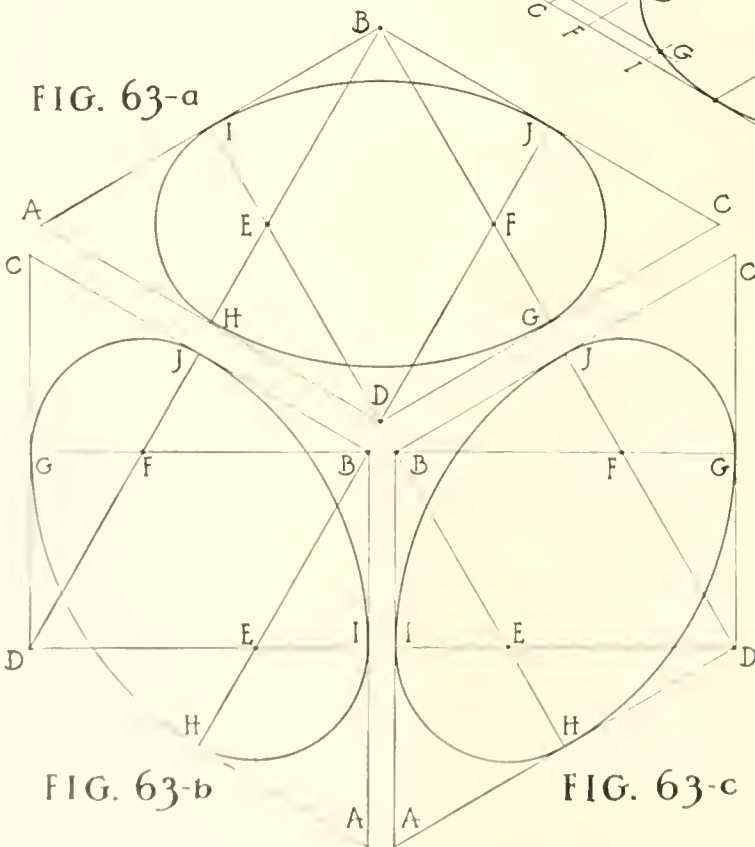

FIG. 63-a

FIG. 63-b

FIG. 63-c

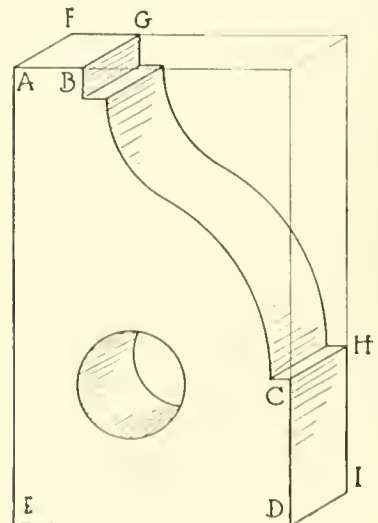

FIG. 64

ARCHITECTURAL DRAWING

If an object is irregular, imagine a transparent rectangular box to be placed around it, the box then drawn in isometric and the object drawn in the box. This has been done in Fig. 61, **Plate II**, where the surrounding box is lettered *A-B-C-D-E-F-G*. Make the rectangular box touch as much of the object as possible; thus the base of this object touches the box all around and the top *K-L-M-N* lies in the top of the box making both of these easy to draw. Locate corner *Q*, which lies in the top of the base, by measuring from *J* to *T* the distance *V-Q* that point *Q* is from face *A-D-E-F*; then draw a 30-degree line from *T* and measure along it to *Q* the distance that *Q* is from the back face *C-D-E* of the box. Draw *Q-P* then *P-O* with the 30-degree triangle and T-square, the length of each being measured directly as they are both isometric lines. Connect *K, L* and *N* with *P, O* and *Q* and the drawing will be completed.

An isometric circle may be made by first drawing a circle with the compass and putting it in a square, Fig. 62a, **Plate II**, then drawing the isometric of the square and then the isometric circle by means of coordinate lines in the isometric square. This has been done in Fig. 62b where the points *A, D* and *G* have been located by the lines *A-B* and *A-C, D-E* and *D-F, G-H* and *G-I*, all of which are isometric lines whose lengths were taken from Fig. 62a and laid off in Fig. 62b.

An approximate isometric circle may be drawn by first drawing the isometric square as before, then the perpendicular bisectors of each side as in Fig. 63a, b and c. It will be seen that these bisectors intersect at *B, D, E* and *F*. With *B* as a center and a radius *B-G*, draw the circle arc from *G* to *H*. With *E* as a center and a radius *E-II* draw a circle arc from *H* to *I*. Then with *D* and *F* as centers complete the isometric circle. Figure 63a is a horizontal circle while Figs. 63b and 63c are vertical circles.

OBLIQUE DRAWING

In isometric drawing the objectionable foreshortening of lines which is found in perspective is eliminated, but the distortion of shape still remains. An object with an irregular or a circular face is rather difficult to draw in isometric just as in perspective. This is noticed in Fig. 62b. To escape this, the method called Oblique Projection may be used. Here the object is considered as having the front face in or parallel to the picture plane and the view taken from a point to one side and slightly above or below the object as in Fig. 64, **Plate II**. That face which is parallel to the picture plane is drawn just the same as in orthographic projection and in this lies the value of the method, for circles may be drawn with the compass, etc. Thus face *A-B-C-D-E*, Fig. 64, **Plate II**, is drawn in its true shape. Then the lines *A-F, B-G, C-H*, etc., are drawn toward the right or left and upward or downward, in any convenient direction, usually at 30 or 45 degrees with the horizontal, and are shown in their true length as in isometric.

The following reminders will serve as a guide to produce the best results:

Where there is an irregular face, place it parallel to the picture plane.

Place the long dimension of the object parallel to the picture plane.

Where the irregular face is the short side of the object, neglect the rule about the long dimension.

CONVENTIONAL SHADOWS

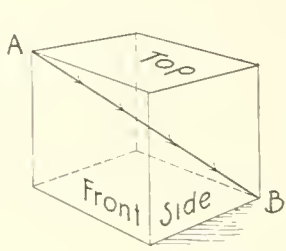

FIG. 65

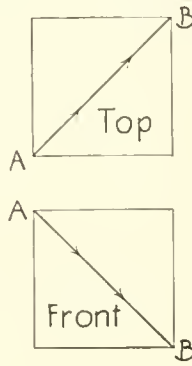

FIG. 65-a

THE CONVENTIONAL RAY OF LIGHT

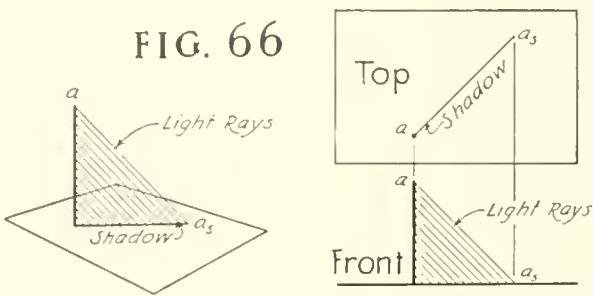

FIG. 66

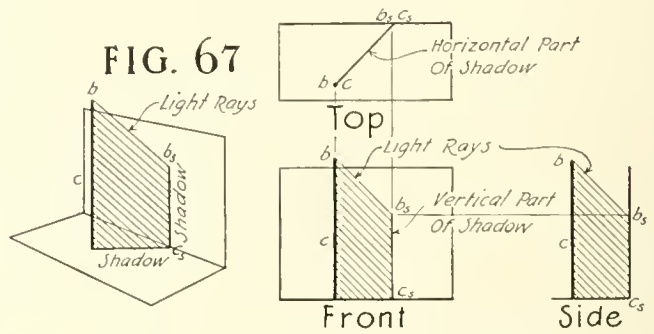

FIG. 67

SHADOW OF VERTICAL LINE ON HORIZONTAL & VERTICAL PLANES

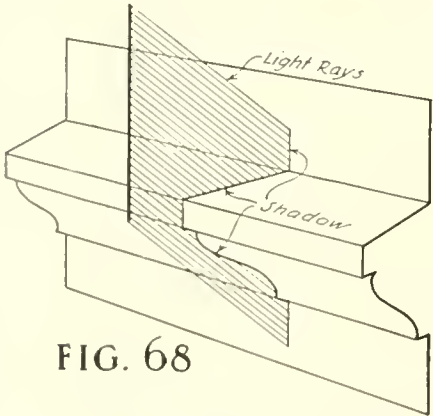
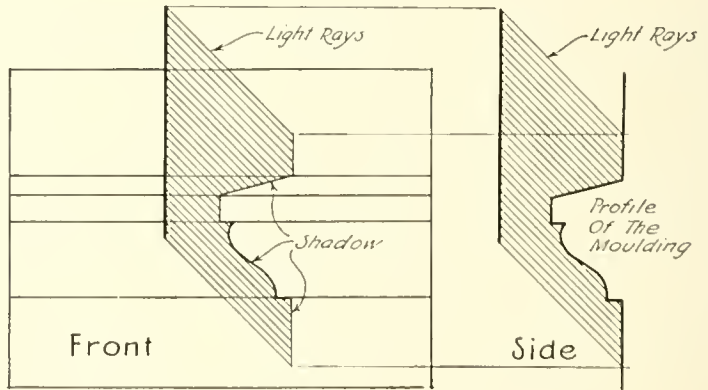

FIG. 68



SHADOW OF VERTICAL LINE ON HORIZONTAL MOULDING

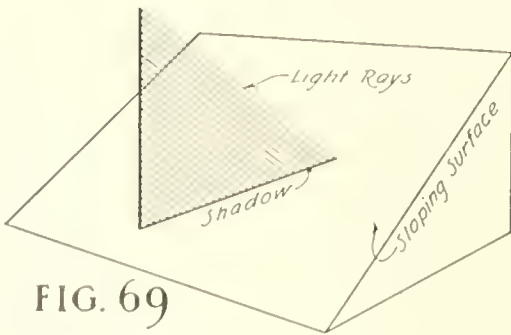
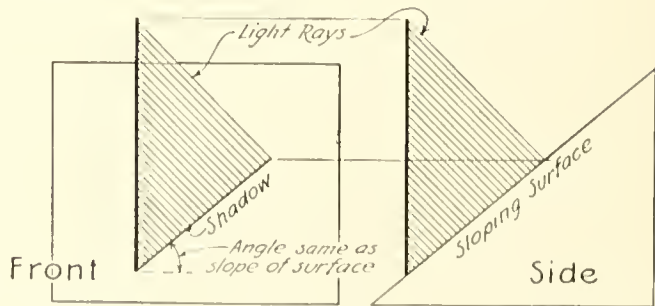

FIG. 69



SHADOW OF VERTICAL LINE ON A SLOPING SURFACE

ARCHITECTURAL DRAWING

SHADES AND SHADOWS

The drawings thus far considered are what are known as line drawings and, because of the fact that they are made up of lines alone, they lack any effect of depth or modeling. This may be gained only by representing the play of light and shade on the various surfaces. The casting of shadows puts the third dimension into the otherwise flat drawing by indicating projections, recesses, mouldings, etc., and thereby livens it up and gives an impression of the third dimension which is entirely lacking in line drawings.

The elements of a building are pleasing to the eye almost solely because of the shadows they cast. Everyone has noticed the dull, flat appearance of even the most beautiful building on a "grey day" and then how interesting it becomes in the bright sunlight. The cornice, for instance, produces a broad band of shadow across the top of the wall; the details of the cornice break this shadow up into interesting variations making of it a richly mottled band of color; see **Plates 15, 16 and 17**. The mouldings of less projection trace narrower lines of shadow across the wall and the spots of ornament enrich the surfaces by their wealth of light and shade; see **Plate 75**. Window and door openings cause dark areas to appear in the composition. These must be carefully considered as they appear prominently in the scheme. Therefore the architect studies the details of his design not alone for beauty of outline but also for the effect of light and shadow that they will produce.

Here again the artistic sense of the designer must be brought into play, but the student can at once learn the mechanical processes by which shadows are determined.

Shadows may be cast either on orthographic projection drawings or on perspectives. The method will be explained in orthographic projection, and the perspective shadows will then be a matter of application of the method. After mastering the principles as here given, the draftsman will be able to cast many shadows with reasonable accuracy by simply visualizing them, and then drawing them without the complete mechanical construction. **Plates 15, 16 and 17** are given to aid in casting the shadows of the Orders of Architecture in the last mentioned manner. Approximate work of this kind should not be attempted until a thorough acquaintance with the subject has been made.

Shadows are cast mechanically by drawing lines (representing rays of light) down past the object which causes the shadow to that upon which the shadow is cast. That part of the object which is turned away from the source of light is said to be in shade and that part of another object from which the light rays are kept by the first is said to be in shadow. The shade line is the line which separates the shaded from the lighted parts of an object and the shadow line is the outline of the shadow. Thus it may be seen that the shadow line is the shadow of the shade line. Some parts of a complicated object may be in shade and other parts of the same object in shadow because of the contour of its surface. This is true of the Attic Ionic base of **Plate 14**.

The sun is of course assumed to be the source of light for most of the architectural shades and shadows. Although the sun's rays are not exactly parallel, they may be assumed to be so in all practical work. A definite position of the source of light is also fixed. For conventional shadows the sun is imagined to be located in front of, above and toward the left of the object, so as to throw the conventional light rays down parallel to the body-diagonal of a cube as in Fig. 65, **Plate 12**. With the front face of the cube toward the observer, the front, top and side views of this body-diagonal will appear as 45-degree lines, Fig. 65a. This makes the conventional light rays easy to draw mechanically and produces shad-

CONVENTIONAL SHADOWS

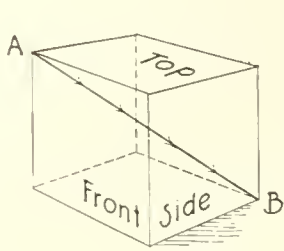

FIG. 65

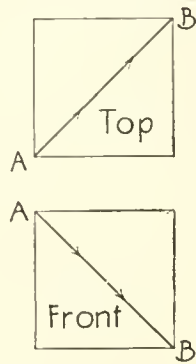

FIG. 65-a

THE CONVENTIONAL RAY OF LIGHT

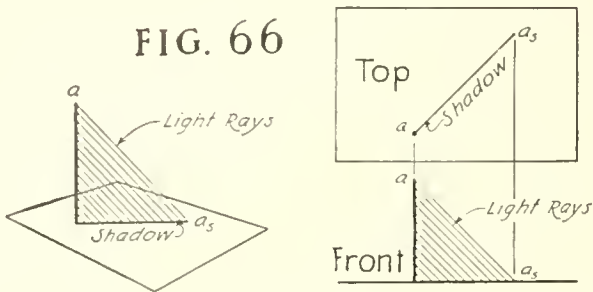

FIG. 66

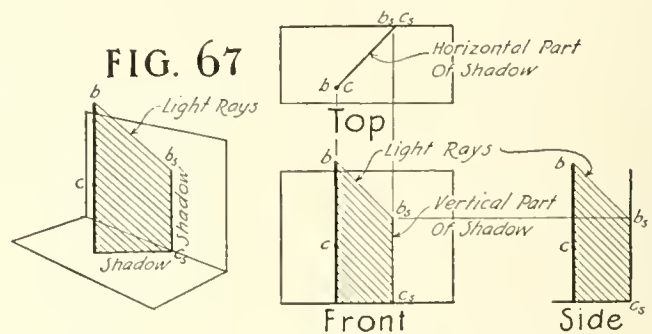

FIG. 67

SHADOW OF VERTICAL LINE ON HORIZONTAL & VERTICAL PLANES

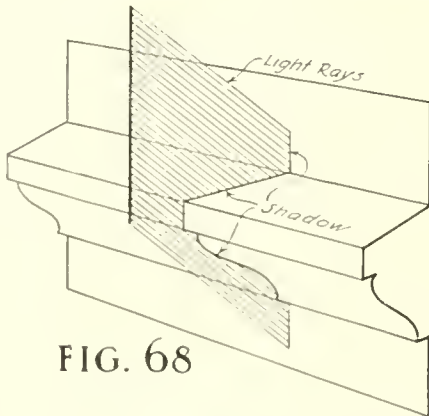
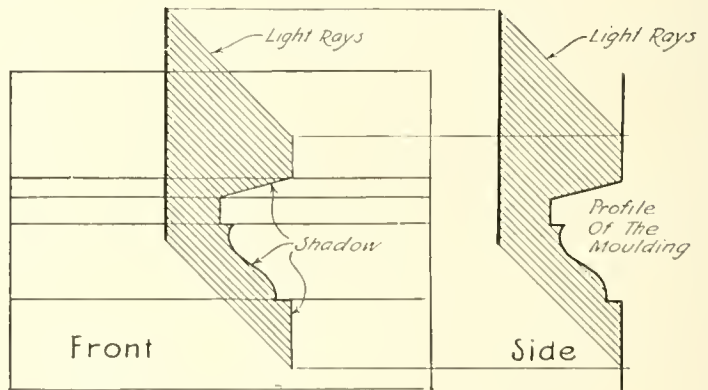

FIG. 68



SHADOW OF VERTICAL LINE ON HORIZONTAL MOULDING

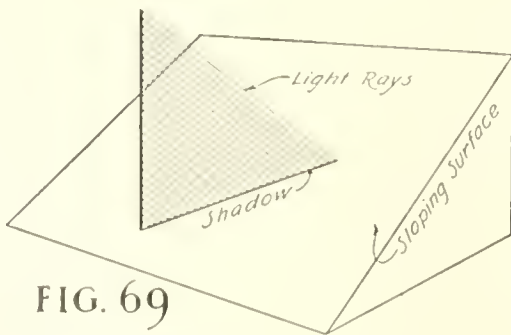
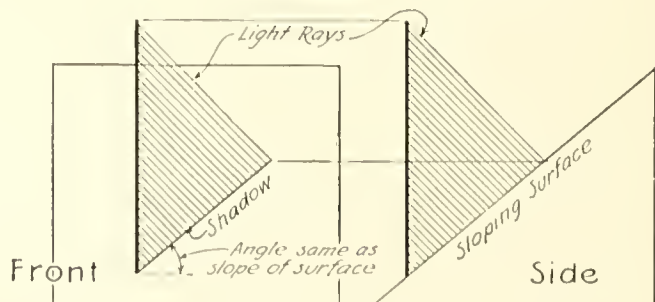

FIG. 69



SHADOW OF VERTICAL LINE ON A SLOPING SURFACE

ows equal in depth to the projection of the object which casts them. Thus a cornice shadow will be just as wide as the cornice projection, **Plate 15**. This fact, if kept in mind, will simplify many problems.

Shadows of Points and Lines.—To cast the shadow of a point upon a given surface draw a conventional ray through the point and to the surface. Where this ray strikes the surface is the required shadow of the point. This is the fundamental operation in all shadow casting, but its application is not always easy, therefore the following detailed helps are given for various cases.

Where the shadow of a straight line is to be cast on a plane surface, Fig. 66, the shadow of each end of the line is located and these points connected to give the shadow of the line. If the given line or the receiving surface is curved, a number of these shadow points are determined and the shadow of the line drawn through them.

In Figs. 66 and 67 of **Plate 12** are shown both pictorially and in orthographic projection, a vertical line casting a shadow on horizontal and vertical planes. It will be readily seen that the shadow of but one point *a* in Fig. 66 is necessary to determine the shadow of the line, while in Fig. 67 two points *b* and *c* must be used.

When a vertical line casts a shadow on a horizontal moulding (or a horizontal line on a vertical moulding), as in Fig. 68 on **Plate 12**, the front view of that shadow is the same as the profile of the moulding. This fact, if remembered, will make short work of many problems which would otherwise be quite tedious. A similar labor saver is shown in Fig. 69 on **Plate 12**. Here it is seen that the shadow of a vertical line on a sloping surface, when viewed from the front, takes the same angle as the slope of the surface. This is useful when working with the shadows of chimneys and dormers on sloping roofs.

SHADES AND SHADOWS

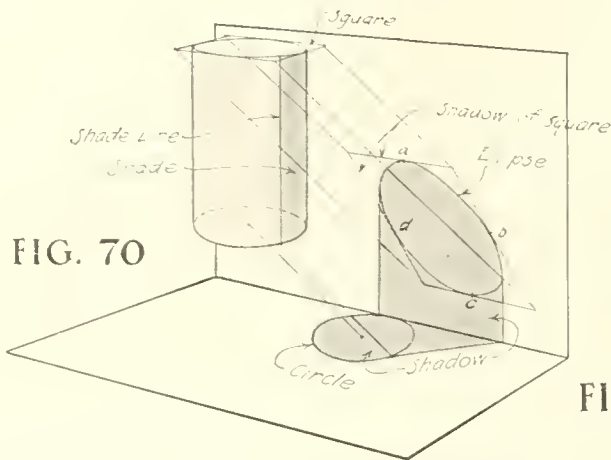

FIG. 70

SHADE & SHADOW OF CYLINDER

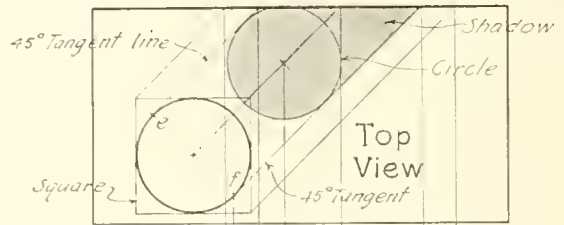

FIG. 70-a

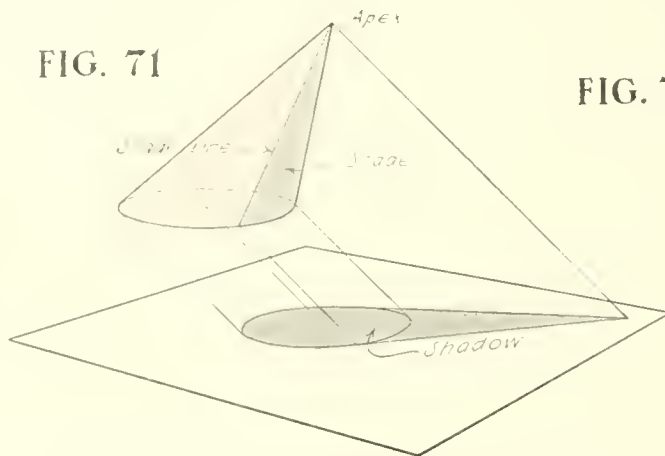
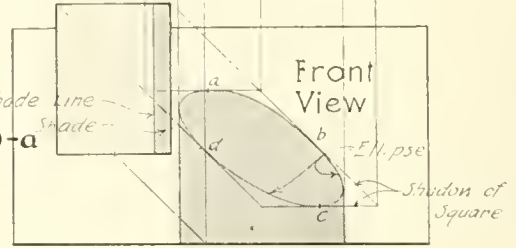

FIG. 71

SHADE & SHADOW OF CONE

FIG. 71-a

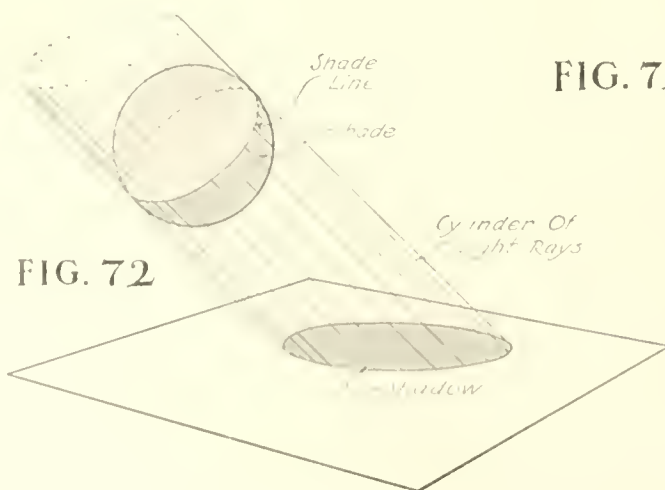
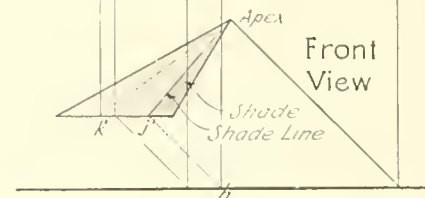
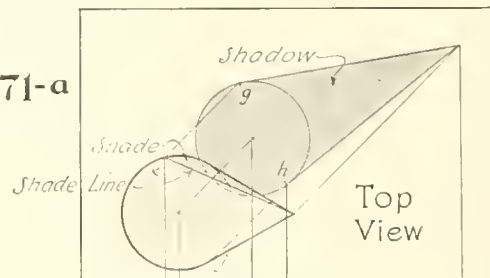
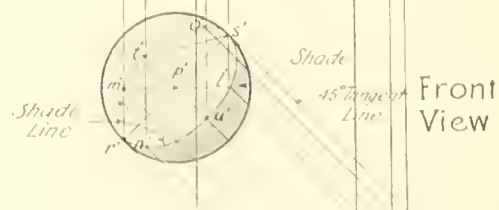
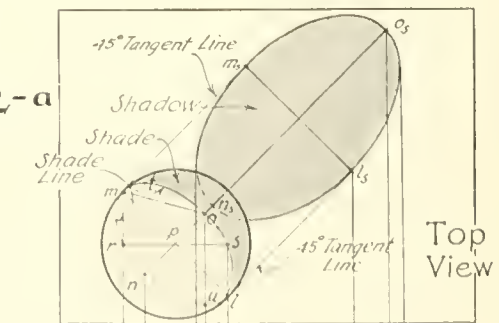

FIG. 72

SHADE & SHADOW OF SPHERE

FIG. 72-a



Cylinders, Cones and Spheres.—If a circle is parallel to a plane surface, its shadow on that surface is circular, and if it is oblique to the surface, its shadow is an ellipse. This is true of circle shadows on any plane surface and is illustrated in the drawing of the three objects on **Plate 13**. A practical way to draw the shadow when it is elliptical is to first draw a square enclosing the circle which casts the shadow, then locate the shadow of the square (as in Fig. 70 and 70a) and in it sketch the ellipse, being careful that it touches and is tangent to the sides of the parallelogram at their center points, a , b , c and d .

Cylinder.—After the circular or elliptical shadows of the ends of the right circular cylinder have been drawn, the straight tangent lines are drawn completing the outline of the shadow. The shade lines of the cylinder are found by drawing the 45-degree tangent lines as noted in the top view, Fig. 70a, and locating the tangent points at e and f . Projecting down to the front view from these points will locate the front view of the shade line.

Cone.—The shadow of a conical object is determined by first locating the shadows of the apex and the base and then connecting the former with the latter by tangent lines as in Figs. 71 and 71a. The shade lines of the cone are found by projecting from the tangent points g and h in the top view, back (at 45 degrees) to the base at j and k , then connecting these points with the apex.

Sphere.—The shadow of a sphere is determined by the use of a cylinder of tangent light rays as in Fig. 72. Since this is a rather tedious process, a shorter method is given; see Fig. 72a. In the top view draw the 45-degree tangent lines through $m-m_s$ and $l-l_s$ and a center line through $n-o_s$ lightly. Draw line $m-l$ through p (at 45 degrees). Draw $m-o$ at an angle of 30 degrees with $m-l$, locating o . Lay off $p-n$ equal to $p-o$. This gives the major and minor axes of the elliptical shade line in the top view. Draw the shade line by the method of Fig. 38, **Plate 5**. Next on the front view draw the 45-degree line $r'-s'$ through center p' . Locate t' by drawing $s'-t'$ at an angle of 30 degrees with $r'-s'$, then lay off $p'-u'$ equal to $p'-t'$ and draw the ellipse as in the top view. The shadows of points m , l , o , and n are found by drawing conventional light rays through the points in the top and front views, locating m_s , l_s , o_s and n_s and drawing the elliptical shadow line in the top view by the trammel method. If the shadow is cast on an irregular or a curving surface, the shadows of a number of points of the shade line may be found and the shadow line drawn through them.

The methods thus far explained are known as oblique projection methods. They are difficult of application where double curved surfaces are to be dealt with. For the solution of a problem involving such surfaces, the slicing method is found useful: This method, while not difficult, necessitates a great deal of very careful work for an accurate shadow.

SHADES AND SHADOWS
OF AN
ATTIC IONIC BASE
BY THE
SLICING METHOD

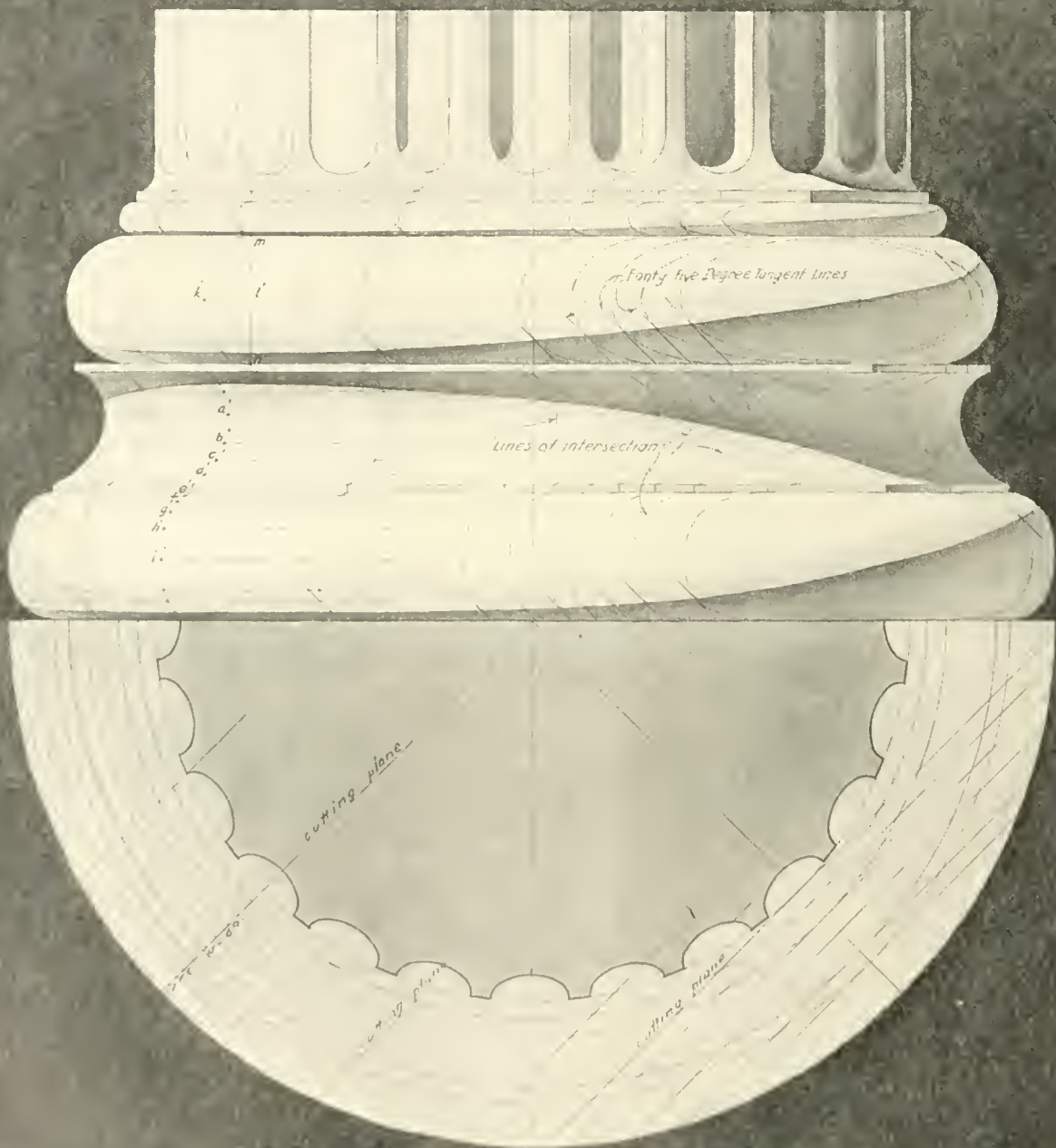

Slicing Method.—Through the column base on **Plate 14** a series of imaginary vertical cutting planes (see also upper left-hand corner of plate) is passed and the lines which these planes cut on the surface of the object are drawn. The cutting planes are passed at 45 degrees in the plan view and consequently contain a number of the conventional rays. Then the lines of intersection are drawn on the elevation (see also upper right-hand corner of plate). These lines of intersection are found by drawing the projections of a series of circular lines on the surface of the base, finding where these circles go through the cutting planes as at *a, b, c, d, e*, etc., in the plan and projecting up to the corresponding lines at *a', b', c', d', e'*, etc., on the elevation. Locate enough points to accurately fix the lines of intersection. Where the cutting planes pass through a moulding of circular section, as the upper two members of this base, the line of intersection with that moulding will be an ellipse, and may be drawn by the method of Fig. 38, **Plate 5**, after the two axes or half-axes have been located, as *m'-n'* and *k'-l'* on the elevation. The cutting planes may be passed through wherever lines of intersection are thought necessary.

Now in the elevation draw the 45-degree tangent lines as shown. These light rays will locate points of tangency and intersection through which the shade and shadow lines may be drawn.

Other Shadows.—Some of the shadows of a building are more difficult to draw as, for example, those of the Corinthian capital and, except for widely isolated cases, these shadows need not be accurately determined. Shadows of the Doric and Ionic Orders are given on **Plates 15** and **16**. **Plate 17** is an example of student work in casting shadows of the Corinthian Order. These will serve as an approximate guide when shadows of the Orders are needed.

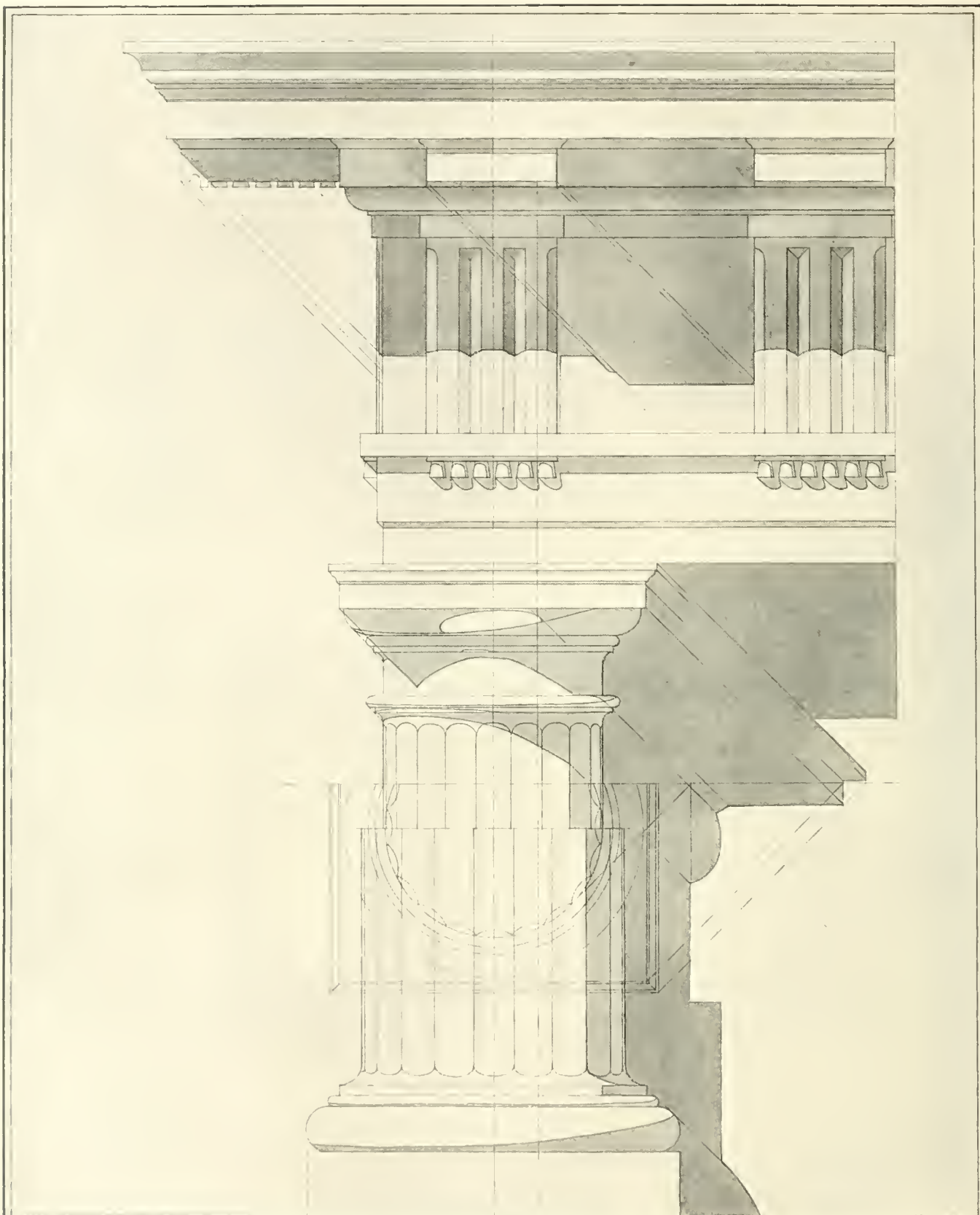

MUTULAR DORIC

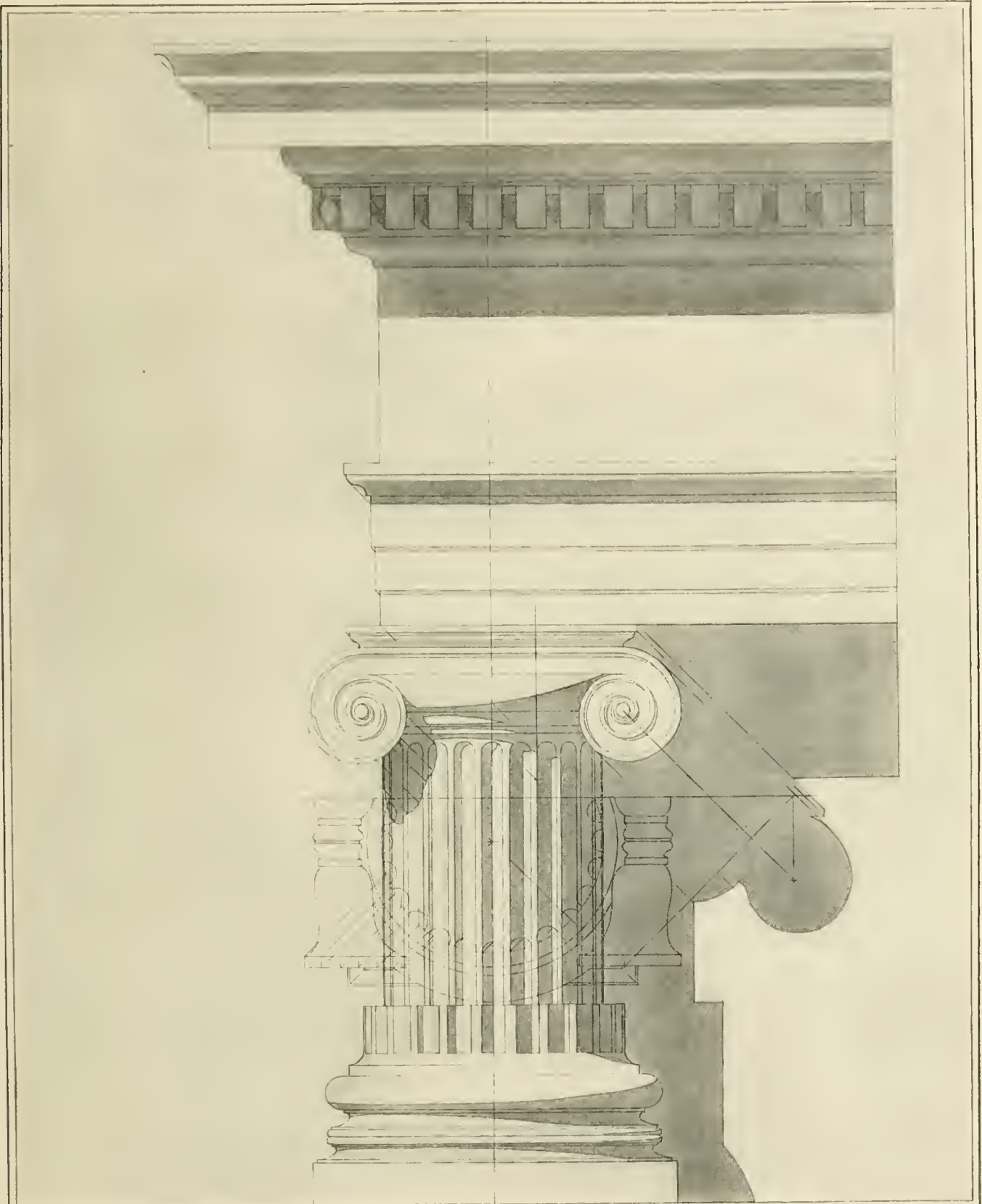

IONIC

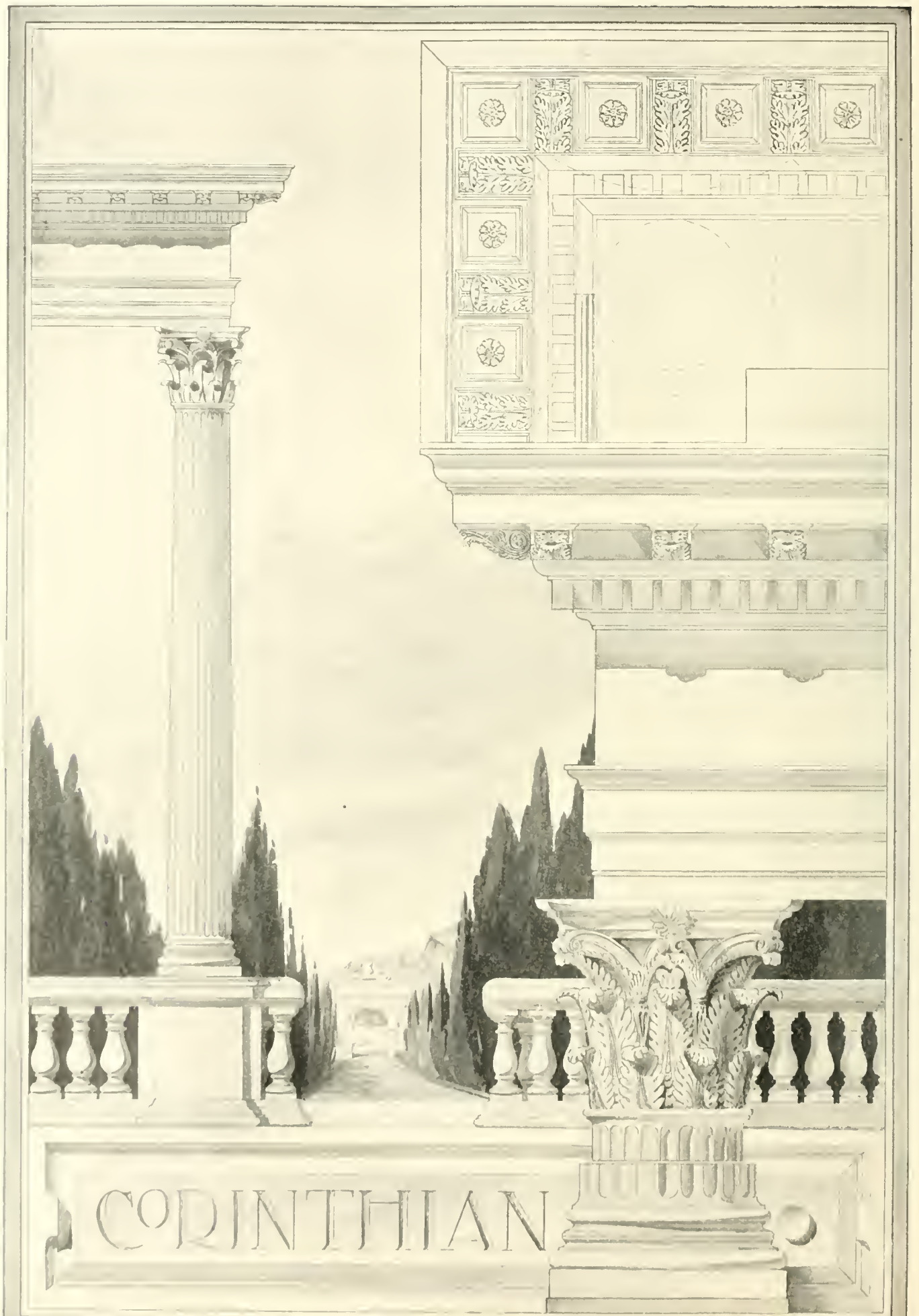

RENDERING

Architectural drawings may be rendered or colored in a number of different mediums according to the result desired. Most common among these are pencil, crayon and water-color. The shadows, the relative color of materials, and the environment of the building may thus be indicated either in monotone or in their natural colors. The medium first used for the rendering of school problems is water-color in monotone washes. These washes are of two kinds, the smooth and the settled wash. In the first the color dries leaving a smooth even tint while in the latter, if applied quite wet and allowed to stand undisturbed, a mottled effect is secured. India ink is perhaps the best color for smooth, soft grey washes, while Charcoal Gray, French Blue and other combinations will produce the settled wash.

Material.—The material needed is as follows:—India ink, which comes in sticks, a slate ink slab in which the ink is ground by rubbing it around on the slate with water, a set of camel's hair or sable brushes which will come to a good fine point when wet, a nest of china water-color saucers, a soft sponge, some white blotters and a piece of clean, absorbent cloth. Later, if the student desires to do color work, he may secure the necessary water-colors. He will have much to learn in monotone however before attempting the other, and should leave that for future development.

Mounting the Paper.—So that the paper will not wrinkle up when water is applied, it must be mounted or pasted down onto the drawing board. For this operation are needed a clean, soft sponge, some white blotting paper and a bottle of Higgin's Drawing Board Paste (not mucilage). There is no paste "just as good." Follow the directions carefully and a satisfactory stretch will be obtained.

Be sure that the board is clean, then lay the paper on it (face up) and, using the sponge, wet the paper thoroughly with clean water, being careful not to rub the surface hard. Squeeze the water from the sponge and take up any that stands in puddles. Turn the paper over, keeping it flat in the process, and wet the back similarly. Take up the surplus water and, with the blotter, take the moisture well out of the paper for a strip about an inch wide all around the edge. It is now ready for pasting. The paste may be taken in a ball beneath the fore fingers of the two hands and run along onto the dried strip around the paper. It is too heavy to be applied with a paste brush and should not be thinned with water. Rub it out until it lies in a very thin coat. If left thick in places it is apt to crack off. Now turn the paper over and press the pasted edges down securely to the board at the same time stretching out all wrinkles and pulling the paper taut. It sometimes helps if a number of thumb tacks are set around the edge until the paste has dried completely. While the paste is drying, keep the center of the paper slightly moist up to within two inches from the edge. This prevents any tension from coming onto the pasted edge before it is dry. When the center is allowed to dry the sheet will be found to have stretched tightly, affording a perfect surface for both drawing and rendering. The stretching of the paper can be overdone and, when such is the case, it may pull so tightly upon drying as to break when moistened again in the rendering of the drawing. It will take the mounting of several sheets to acquaint the student with the ins and outs of the process.

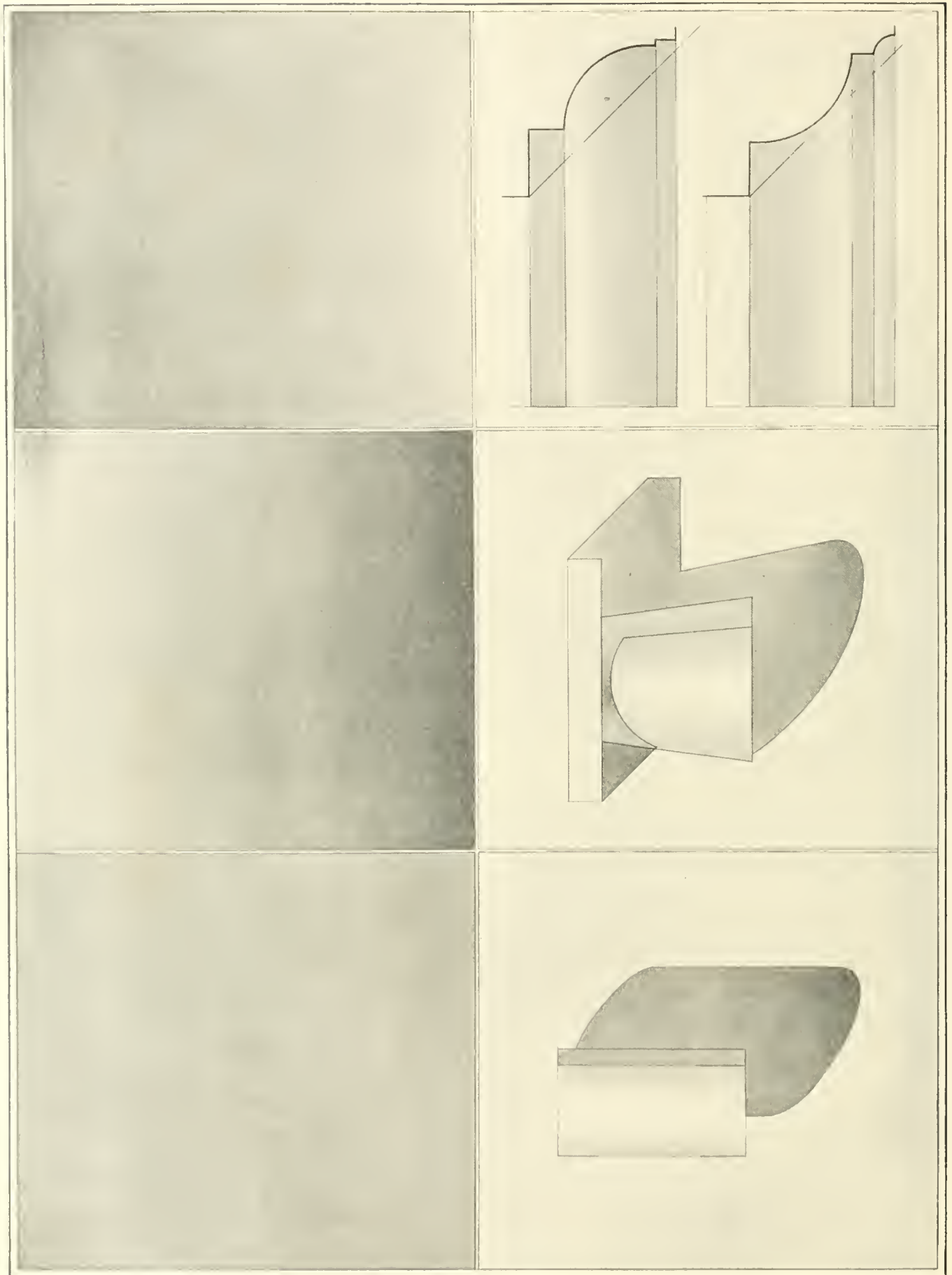

Practice Sheet.—After the paper has been mounted, a practice sheet should be laid out and rendered in monotone. **Plate 18** is a suggestion for this sheet. It contains an even wash, one graded from light down to dark, one from dark to light, and the shades and shadows of two simple objects and two mouldings. This sheet should be mastered before any other work in rendering is attempted. A practical size for the sheet is about 14 by 19 inches, divided into six equal parts as indicated. The cylinder in the fourth space is $1\frac{1}{2}$ inches in diameter and 3 inches long and its center line is $\frac{7}{8}$ inch in front of the wall on which the shadow is cast. The Gutta in the next space is $2\frac{1}{2}$ inches in diameter at the bottom, $1\frac{7}{8}$ at the top and is $2\frac{1}{4}$ inches high. It is suspended from a $3\frac{5}{8}$ by $1\frac{5}{8}$ by $\frac{1}{2}$ -inch block and its center line is $\frac{3}{8}$ inch in front of the wall. The mouldings of the last space may be drawn approximately as shown.

Laying the Washes.—First prepare the india ink in the slate slab, then mix it in three or four different intensities in the china saucers. Wet the paper, using the sponge and clean water, then take up all water which stands on the surface. If the paper is not damp it will be difficult to prevent the color from drying quickly and producing hard lines in the wash.

Find by trial on the border of the paper if the most dilute saucer of ink is of the desired intensity for the first exercise. With the brush full of this ink begin at the top of the space, and, working from side to side, lay on the wash as quickly as possible, keeping the board slightly tilted so that the surplus color will drain toward the bottom of the space. When the lower line is reached, squeeze the color from the brush and take up the surplus color from the paper with the brush tip. Care must be exercised to prevent one part of the wash from drying more quickly than another as this is fatal to a smooth wash. The ability to do this well can come only by practice.

The second wash is laid similarly except that the first brush full at the top of the space is clear water. Then a brush of diluted ink from the next saucer is used and so on, each brush full being darker than the other until the darkest part at the bottom is reached. The even grading of the result will depend upon the skill and care with which the darker color is added.

In the third rectangle the previous process has been reversed, the darkest color used at the top and more water added as the wash progresses downward.

The objects in the lower rectangles are given to illustrate the fact that both lights and shadows vary in intensity. The surface or part of a surface to which the sun's rays are perpendicular, is always the brightest, and the degree of brightness diminishes as the surface is turned away from this position. These contrasts become less pronounced as the distance from the observer to the object increases. This fact may be employed in rendering to give the effect of relative projection of building parts. The walls nearest to the observer are rendered more brilliantly than those at a distance and the detail of the distant parts is kept less distinct than that close up. The student can observe this everywhere in nature. The greater the distance, the more indistinct the detail and color contrasts.

In rendering a curved object such as the cylinder of **Plate 18**, its lighted surface should first be modeled by a very light graded wash as indicated, showing the parts of greatest light intensity, etc. Then the shaded part and the shadow should be similarly treated. It will be noticed that the shadow is slightly darker than the shaded surface. This is caused by light being reflected back onto the shaded surface from the bright parts of the wall on which the shadow is cast. Because of this reflected light, the brightest part of the shade of a curved surface is usually directly opposite the most intensely illuminated point. The shade line of such a surface is not really a distinct, clean-cut line, but shadow lines are always sharp and well defined. The mouldings illustrate the principle of reflected light in shade and shadow.

The Attic base of **Plate 14** will also serve to illustrate the varying intensities of light and shade and the effect of reflected light.

ARTICLE V
SCALE DRAWINGS

Plates 19 to 45

Working drawings consist of all plans, elevations (both exterior and interior), sections, scale details and full size details necessary for the adequate completion of the work.

The scale drawings of a building are those which show the general layout of the building as a whole, locating the various features of the scheme, showing their relation to each other and giving the principal dimensions.

The scale drawings of the architect correspond in a sense to the assembly drawings of the machine designer. The characteristic of the architect's scale drawing is that it deals with general conditions and represents them by symbols rather than to show each feature exactly as it would appear. On **Plates 19** and **20** are given these symbols which represent the various materials of construction and the fixtures which are usually found in the average building. The use of the plan symbols is illustrated on **Plates 21, 22** and **23**.

In general, when any feature is to be given afterward in a detail drawing, it is shown on the scale drawing merely by a quickly made symbol or a note. This is also true of features with which the builder is familiar and of which there will be no detail drawn. Do not indicate or dimension a feature in detail on the scale drawings when you intend later to make a large scale or full-size drawing of it, as this would be useless repetition.

For example, a fireplace is often located on the scale drawings by dimensioning to its center line on the plan and giving but few other figures. Then on the detail, everything is carefully shown and thoroughly dimensioned.

Thus it will be seen that the scale drawing is merely an indication while the accurate description is left for the detail.

Determination of Scale.—The first thing to be decided about the so-called scale drawings is the scale at which they shall be drawn. This is fixed by the size of the building and the degree of fineness with which we wish to go into detail.

The average residence is drawn at a scale of $\frac{1}{4}'' = 1' - 0''$, while a very large house must be drawn at a scale of $\frac{1}{8}''$ or $\frac{1}{16}'' = 1' - 0''$. In deciding the size of the sheet to use, bear in mind the fact that the tracing cloth and blueprint paper of which we will hear later, come in widths of 30, 36 and 42 inches and sometimes wider. For sizes of other paper see page 10.

Method of Laying Out the Drawing.—Plans are usually drawn with the front of the building toward the bottom of the sheet. If however the building is very deep and narrow, this may not be possible.

The principal plan should be laid out first. This in most buildings will be the first floor plan. Then the second, third, etc., floor plans are drawn, the basement plan usually being drawn last. This is almost always the best order of procedure, no matter what the building may be.

Center Lines.—If the plan is to be symmetrical about a center line, this line is the first thing to be drawn and the plan worked out each way from it. Ink this center line to prevent its being erased when changes are made in the pencil drawing. Notice how the plan on **Plate 32** has been worked from the several center lines. This is true also of elevations; see **Plate 24**.

After locating the center lines if there are any, lay out the rooms according to the previous approximately determined dimensions without indicating doors or windows. Draw the lines very lightly with an *H* pencil.

Location of Doors and Windows.—Now locate the doors and windows by center lines only. Second story windows are usually located directly above those of the first story but this is a matter to be determined by the design of the elevation as is also the width of these openings. After the elevations have been worked up, these features may be drawn on the plans, using the symbols of **Plates 19 to 23** and **48 to 51**.

The Width and Kind of Doorways and other openings, will be determined by the kind of building with which the draftsman is concerned or by the use to which the building will be put. Thus the front door of a residence should not be less than 3' - 0" wide and other outside doors not less than 2' - 10" wide. The communicating doors or those in the partition walls of a residence should be at least 2' - 8" wide to allow the passage of furniture. Closet doors may be 2' - 6" wide or less.

Door Heights will vary according to the design of the room. Sometimes a panel is placed above the door to give a feeling of additional height. It looks well in a residence to have both window and door heads at the same height above the floor if this can be done.

The term *right-hand* or *left-hand door* will be met with and should be understood. When you enter the house, if the door opens away from you and swings toward your right, it is a right-hand door; if it swings away from you and toward your left, it is a left-hand door. A knowledge of this is quite important in buying hardware.

Influence of Stock Material.—Stock sizes of material often have a bearing on the design of a building. This is particularly true of residence work. For example, joist come only in even lengths, and if a room were 14' - 0" \times 20' - 0" the nearest size of joist to span this room would be 16' - 0" long, leaving a waste of about 1' - 4" for each joist. If this room were made 13' - 4" or 15' - 4" wide the entire 14' - 0" or 16' - 0" joist could be used, for the joist extend into the wall about 4" at each end. Of course it is not always possible to prevent this waste.

Wall thicknesses are fixed by the material of which the wall is built. A frame wall is about 6 inches thick, a brick wall is 9, 13, 17, etc., inches thick and stone walls vary from 12 inches up.

Where soil pipes are placed in the walls, the pipe joints would project through the plaster and into the room if 4 inch studs or framing timbers were used. To prevent this the studs must be furred or framed out far enough so that the plaster will cover the pipe. Sometimes 6-inch studs are used in such a wall.

Window glass comes in even sizes and for this reason it is well to make all window frames of a size to take the stock glass, particularly if there are a great many of the lights to be furnished.

PLAN SYMBOLS FOR PLUMBING FIXTURES

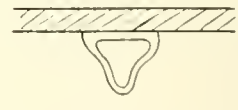
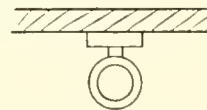
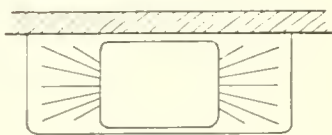
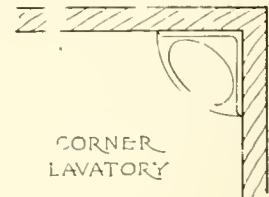
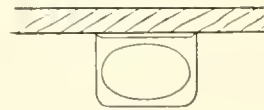
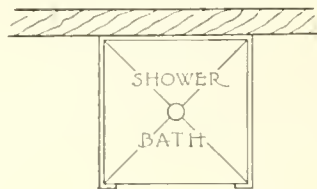
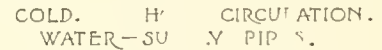
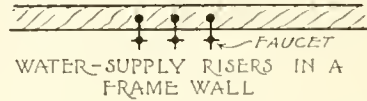
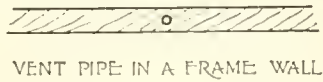

SYMBOLS FOR BUILDING MATERIAL

IN SECTION

IN ELEVATION

IN SECTION

IN ELEVATION



WOOD



BRICK

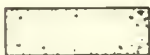
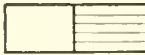

CUT STONE

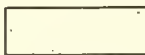

RUBBLE MASONRY

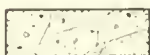

MARBLE

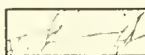

STRUCTURAL TILE

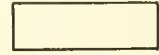

TERRA COTTA

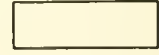

PLASTER OR STUCCO

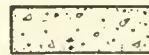
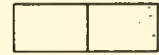

CONCRETE OR CEMENT

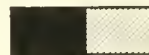



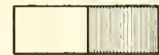

































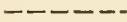

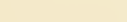
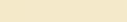





METAL



DUE TO THE FACT THAT THE PLANS OF DIFFERENT DRAFTSMEN WOULD BE LIKELY TO HAVE THE VARIOUS FIXTURES ETC. REPRESENTED IN WIDELY DIFFERING MANNERS, IT IS WELL TO ACCEPT A STANDARD SYMBOL FOR EACH FEATURE OF THE BUILDING. THIS MAKES FOR EASE IN THE INTERPRETATION OF THE DRAWINGS BY EVERYONE CONCERNED. THE SYMBOLS GENERALLY USED FOR PLUMBING AND HEATING FIXTURES ARE AS SHOWN. THE WIRING SYMBOLS HAVE BEEN ADOPTED BY THE NATIONAL CONTRACTORS ASSOCIATION AND THE AMERICAN INSTITUTE OF ARCHITECTS AND ARE ACCEPTED BY MOST OFFICES. THE SYMBOLS USED FOR PIPING AND FOR BUILDING MATERIAL ARE AT GREATER VARIANCE, MOST OFFICES ESTABLISHING THEIR OWN STANDARD ACCORDING TO THE NEEDS OF EACH CASE. IF THIS IS DONE, A KEY TO THESE SYMBOLS SHOULD ACCOMPANY THE DRAWING.

SYMBOLS FOR MATERIAL AND FIXTURES

















PLAN SYMBOLS FOR ELECTRIC FIXTURES (COPYRIGHTED)

-  CEILING OUTLET. THE NUMBER INDICATES THE NUMBER OF 16 CANDLE POWER LAMPS.
-  COMBINATION (ELECTRIC AND GAS) CEILING OUTLET. +ELECTRIC AND 2 GAS LAMPS.
-  WALL BRACKET OUTLET. NUMBER INDICATES NUMBER OF 16 C.P. LAMPS.
-  COMBINATION (ELECTRIC AND GAS) WALL OUTLET WITH 2 ELECTRIC AND 1 GAS LAMPS.
-  OUTLET IN WALL, USUALLY IN BASEBOARD. NUMBER INDICATES 16 C.P. LAMPS TO BE ACCOMMODATED.
-  FLOOR OUTLET. NUMBER INDICATES NUMBER OF 16 C.P. LAMPS TO BE ACCOMMODATED.
-  OUTLET FOR OUTDOOR STANDARD OR POST. NUMBER INDICATES 16 C.P. LAMPS.
-  COMBINATION OUTDOOR OUTLET FOR STANDARD. 4 ELECTRIC AND 2 GAS LAMPS.
-  DROP CORD OR SUSPENDED OUTLET.
-  ONE-LAMP OUTLET FOR LAMP RECEPTACLE.
-  ARC LAMP OUTLET.
-  SPECIAL OUTLET FOR LIGHT, HEAT OR POWER.
-  CEILING FAN OUTLET.
-  SINGLE POLE SWITCH OUTLET.
-  DOUBLE POLE SWITCH OUTLET.
-  THREE-WAY SWITCH OUTLET.
-  FOUR-WAY SWITCH OUTLET.
-  AUTOMATIC DOOR SWITCH OUTLET.
-  ELECTROLIER SWITCH OUTLET.
-  METER OUTLET.
-  DISTRIBUTION PANEL.
-  JUNCTION OR PULL BOX.
-  MOTOR OUTLET. NUMBER INDICATES HORSE-POWER.
-  MOTOR CONTROL OUTLET.
-  TRANSFORMER.
-  MAIN OR FEEDER-RUN CONCEALED UNDER THE FLOOR.
-  MAIN OR FEEDER-RUN CONCEALED UNDER THE FLOOR ABOVE.
-  MAIN OR FEEDER-RUN EXPOSED.
-  BRANCH CIRCUIT-RUN CONCEALED UNDER THE FLOOR.
-  BRANCH CIRCUIT-RUN CONCEALED UNDER THE FLOOR ABOVE.
-  BRANCH CIRCUIT-RUN EXPOSED.
-  POLE LINE.
-  RISER.
-  TELEPHONE OUTLET. PRIVATE SERVICE.
-  TELEPHONE OUTLET. PUBLIC SERVICE.
-  BELL OUTLET.
-  BUZZER OUTLET.
-  PUSH BUTTON OUTLET.
-  ANNUNCIATOR. NUMBER INDICATES THE NUMBER OF POINTS.
-  SPEAKING TUBE.
-  WATCHMAN'S CLOCK OUTLET.
-  WATCHMAN'S STATION OUTLET.
-  MASTER TIME CLOCK OUTLET.
-  SECONDARY TIME CLOCK OUTLET.
-  DOOR OPENER.
-  SPECIAL OUTLET FOR SIGNAL SYSTEMS.
-  BATTERY OUTLET.

PLAN SYMBOLS FOR GAS PIPING

-  MAIN OR SUPPLY PIPE CONCEALED UNDER THE FLOOR.
-  MAIN OR SUPPLY PIPE CONCEALED UNDER THE FLOOR ABOVE.
-  MAIN OR SUPPLY PIPE EXPOSED.
-  STREET GAS MAIN.
-  BRANCH PIPE CONCEALED UNDER THE FLOOR.
-  BRANCH PIPE CONCEALED UNDER THE FLOOR ABOVE.
-  BRANCH PIPE EXPOSED.
-  RISER.

HEATING AND VENTILATING SYMBOLS

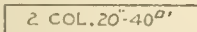
-  STEAM PIPE LINE.
-  RETURN LINE.
-  EXHAUST LINE.
-  DRIP LINE.
-  GLOBE VALVE.
-  GATE VALVE.
-  CHECK VALVE.
-  ELBOW.
-  TEE.
-  RISE OR DROP.
-  TEE RISE OR DROP.
-  ELBOW RISE OR DROP.
-  STEAM OR HOT WATER RADIATOR.
-  HOT AIR REGISTER IN 6" WALL.
-  VENT. REGISTER IN 6" WALL.
-  HOT AIR REGISTER IN FLOOR.
-  VENTILATING REGISTER IN FLOOR.
-  NUMBER OF COLUMNS AND NUMBER OF SQ. FT. RADIATING SURFACE NOTED.
- ALWAYS NOTE ON THE DRAWING THE KIND AND SIZE OF REGISTERS.
-
-
-

SYMBOLS FOR FIXTURES

Elevations.—Before developing the plans very far the elevations should be blocked in and the plans and elevations carried along together to secure the best result. It is well to draw the elevations on transparent tracing paper as this facilitates the work. This paper may be laid directly over the plan and locations read through it.

An elevation should indicate everything on the outside of the building from the grade to the chimney caps and that portion of the basement wall which is out of sight in the ground should be shown by dotted lines as on **Plates 24 to 27**.

First decide on the *story heights* or distances from floor to floor and mark them out on the sheet. Now draw the *floor lines* across the sheet as shown on the above mentioned plates. They should be inked to prevent their being erased when changes are made in the pencil drawing. Some draftsmen like to use red ink for this, as the floor levels are easily found among the other lines. If the elevation is to be symmetrical, draw the *center line* or *lines* next and ink them.

Now the *grade line* representing the surface of the ground is drawn at the desired distance from the first floor line. Sometimes both the natural and finished grades are shown, the latter by a solid line and the former by a dotted one. Both of these should then be plainly noted as on **Plates 24 to 27**.

A temporary *vertical wall section* should now be drawn at one side of the sheet extending from the footing up through the cornice. It should contain the vertical section of a typical window in each story, sections through the floors, and a typical cornice section. This need not be drawn in detail here but just complete enough to assist in drawing the elevation.

Next draw the center lines of windows and doors very lightly and draw in the windows and doors as desired. After this is done they may be placed on the plans.

Any other features, such as porches, hoods, bays, dormers, etc., should now be drawn on the elevations and plans.

If the stairway is next to an outside wall it is often shown by dotted lines on that elevation to which it is adjacent. This is of particular value where windows occur on the stair or landing as it gives a definite means of locating them vertically. See **Plate 37**.

On the elevation of a frame house the boards are indicated by fine lines and on a brick house the horizontal brick joints are sometimes similarly shown. This lining is usually shown on just enough of the elevation to make clear of what the wall is built. Stone joints are indicated in a like manner. When the drawing is inked the joints are often shown in diluted ink which differentiates them from the other ones as explained under the subject of *Reproduction of Working Drawings*.

ARCHITECTURAL DRAWING

Where ornament occurs on the elevation it is often omitted from the scale drawings and its location shown by merely its outline or by a note, see **Plate 43**, or else only a small portion is indicated and its continuation or repetition is noted.

When some exterior walls can not be described on the front, rear or side elevations (such as certain court walls), they must be drawn separately and given an explanatory title.

In all of this elevation drawing the perspective effect or actual appearance of the resulting structure must be kept in mind as this will often vary materially from the appearance of the projection drawing. See article on Perspective and **Plate 9**.

Scale Details.—After the plans and elevations are well worked up the draftsman must make the scale details. These are detail plans, elevations and sections drawn at a scale of $\frac{1}{2}''$, $\frac{3}{4}''$, $1\frac{1}{2}''$ or $3'' = 1' - 0''$ according to the amount of definition to be shown. They are used for conditions where small scale drawings will not suffice and where full-size details are not necessary. See **Plates 28 to 30 and 36 to 38**.

Dimensioning.—After the drawings have been made, the sizes of the various features and their location in the building must be definitely given by dimensions.

First and foremost, *these dimensions must be made clearly* and so that they can not be read incorrectly. Too much emphasis can not be laid on this statement. The figures given in the article on lettering are the most legible and best for use on working drawings. The accompanying drawings show how the dimension lines should be made. The dimension in any case means the distance from arrow point to arrow point, so care must be exercised that these arrow points be located in exactly the right place.

When possible, keep dimensions off the object. Thus on **Plate 22** the arrow points often touch two lines extending out from the plan. These are called extension lines or reference lines and are made very lightly. Extension lines are drawn through the centers of windows, doors, etc., for the purpose of locating them on the plan.

No line of the drawing and no center line should ever be used as a dimension line.

Dimensions should read from the left toward the right and from the bottom toward the top of the drawing. In any case they should read with the dimension lines, not across them. This is illustrated on the Cochran plans.

Dimensions should always be given to the face of masonry walls, to the outside of studs in outer frame walls, to the center lines of frame partitions, to the center line of beams, girders and columns and to the center line of door and window openings. In any case they must be given so as to best aid the workman who is doing the building. Give them also in such a way that variation in stock sizes of material will not affect the result.

In addition to the dimensions to centers of openings in masonry walls, the width of the opening should be given. This is necessary in getting out stone sills, steel lintels, etc.

Whenever possible, keep dimensions off of sectioned surfaces.

ARCHITECTURAL DRAWING

A careful study of the accompanying drawings will show the best ways of indicating dimensions under various circumstances. Information concerning the dimensioning of stairways, fireplaces, etc., is given with the details of those features.

It is very easy to spoil a good drawing by poorly made dimensions so the form of the figures and the shape and location of the arrow points should be carefully watched.

Notice on **Plate 22** and **Plate 32** how the detail dimensions are given on one line, the larger dimensions on a line outside the detail dimensions and the over-all dimensions are outside of them all whenever possible.

In general, the vertical dimensions are given on the elevations and vertical sections and the horizontal dimensions on the plans. Verify this by consulting the plates.

The plans, elevations and sections on **Plates 21** to **30** give the student a comprehensive idea as to the drawings necessary for a complete graphic description of the average residence.

Of course for a cheap house where a great deal of stock material is to be used, the drawings might be much more simple, but for good work, each feature should be carefully presented.

Notice the scale at which the drawings are made and the amount of detail shown on each.

Reproduction of Working Drawings.—After the building is drawn up, a number of sets of the drawings must be made to supply each of the contractors with a copy and to replace those worn out on the job. These are made by placing a sheet of transparent tracing cloth over the pencil drawing and tracing all lines, notes, dimensions, etc., on the cloth in black drawing ink. This *tracing* is then placed in a frame over a white sensitized paper called *blueprint paper* and exposed to the sun or an artificial light. The light causes a chemical change in the emulsion on the paper which, immersed in water, causes the paper to turn a deep blue wherever the light has reached it. The black ink lines prevent the light from reaching the emulsion and so all lines, notes, etc., develop out white in contrast with the blue background making a very legible *blueprint*. After the print is washed it may be exposed to the light without causing any further chemical change.

This method of reproduction is both cheap and practical for working drawings. In all cities and towns of any size may be found blueprinting establishments, and the architect can have this work done more cheaply than he can do it himself.

Sometimes blueprints are made directly from pencil drawings on tracing paper but they are not so sharp and brilliant as those made from the cloth tracings.

When the draftsman desires some of the lines of the blueprint to show rather dimly, he traces them in diluted black ink. This allows some light to filter through and produces bluish lines which are not so prominent on the print as the white lines. These are valuable in showing brick jointing, section lining, etc.

Drawings of Existing Buildings.— When it is found necessary to make alterations or additions to an existing building, the draftsman finds himself in need of a graphic record of the structure as it stands. If the original drawings of the building are not available, it is necessary that measurements be made and recorded in some quick and accurate manner so that workable plans, elevations, etc., may be drawn from them. The amount of detail and care with which this record must be made will be determined entirely by the new work to be done and will vary with every case.

The first record is made on coordinate paper. This paper is ruled vertically and horizontally with lines $\frac{1}{8}$ inch apart forming $\frac{1}{8}$ inch squares. Every eighth line is heavier than the other seven, thus forming 1 inch squares also. As the sketches are usually made at a scale of $\frac{1}{8}'' = 1' - 0''$, the plans, elevations, etc., may be easily drawn on this paper in good proportion, for each small space represents one foot at this scale. The paper should be fastened to a piece of cardboard or other lightweight board so that it may be easily carried and marked on. A 6 foot folding rule and a steel tape will be needed for making the measurements.

Care should be exercised to make the notes complete at first, for if anything is omitted, much time may be wasted in repeated trips to the building for the missing information.

First, the floor plans should be measured and recorded. These should show all principle dimensions of rooms, the location of stairways with the number and dimensions of the risers and treads; then the thickness and material of all walls, the width, character and location of all wall openings and then any other features such as heating and plumbing equipment, etc., are recorded. In connection with the plans, any horizontal sections, such as window jambs, etc., may be detailed as needed. As a check to the numerous smaller dimensions of the plan, over-all measurements should be taken. They may be secured outside the building or on a straight line through the inside where doors are conveniently located.

In recording the vertical dimensions, the story heights should be secured first. This may be done by dropping the tape down through a stair well where the building is such as to make this possible. They may be measured also on the outside wall from sill to sill of the windows and then adding the sill-to-floor dimensions of the lower story and subtracting corresponding dimension of the upper story. The height and detail of belt courses, cornice, etc., must then be secured. At least one of each type of window and door openings should be shown in detail on these sketches. Where it is impossible to measure outside heights directly, the number of brick courses or of siding boards may be counted and, by measuring these features where they are within reach, the inaccessible dimensions may be arrived at. Another method of obtaining such dimensions is by taking photographs of the elevations, preparing a scale from known dimensions on the picture and using this to measure those parts that are out of reach. Roof slopes, chimney heights, etc., may also be found if the pictures have been taken from the proper station points. The photographic record will be found of much value in the subsequent work.

SHEET 2

THE HOUSE OF
 MR. RAE & E. COCHRAN
 GLENCO ROAD, DOMINION PARK,
 COLUMBUS, OHIO.
 WOOSTER BAND FIELD ARCHT.
 COLUMBUS, OHIO.

MAY
 31
 1919

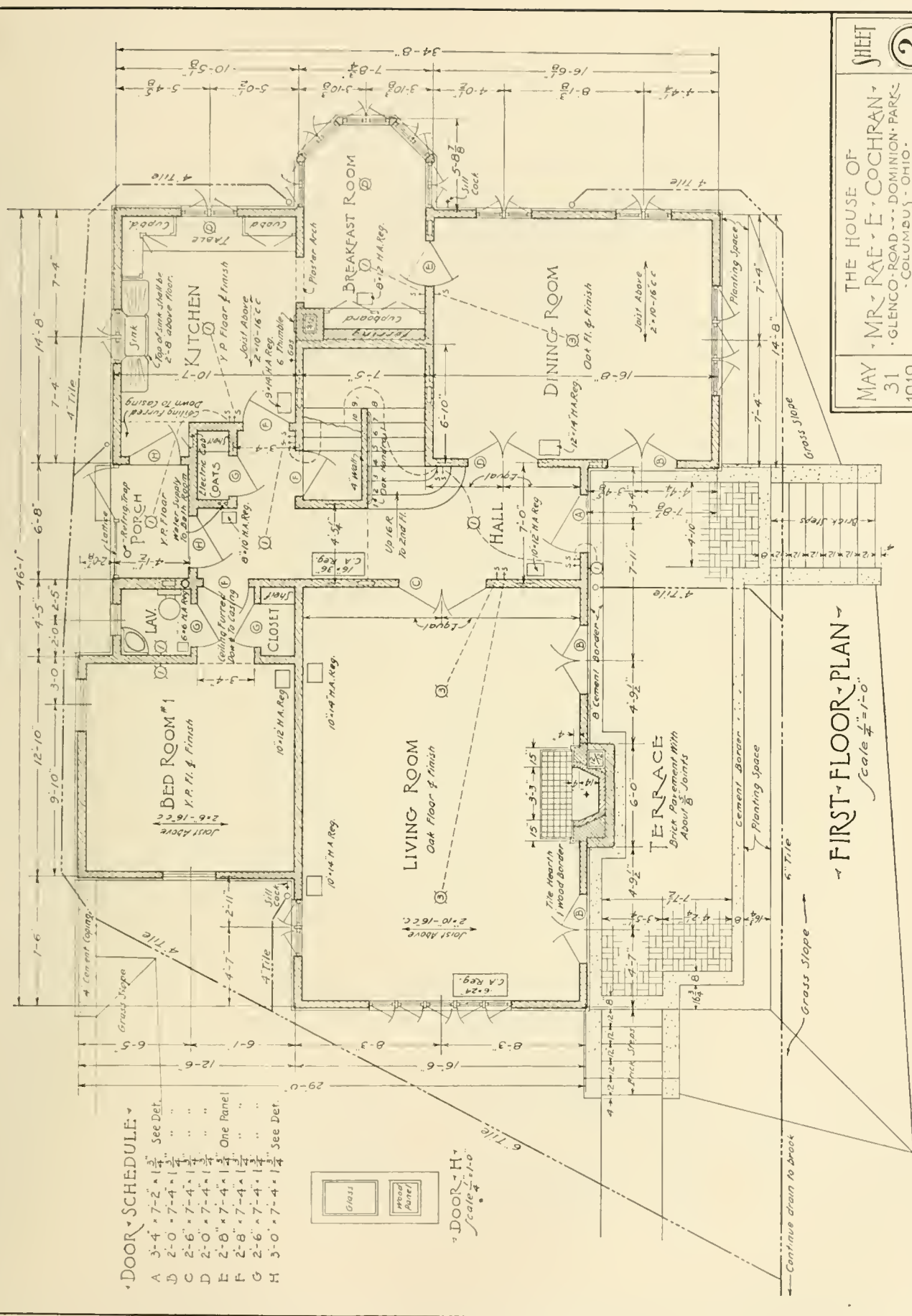

DOOR SCHEDULE

A	3'-4" x 7'-2"	See Det.
B	2'-0" x 7'-4"	"
C	2'-6" x 7'-4"	"
D	2'-0" x 7'-4"	"
E	2'-8" x 7'-4"	One Panel
F	2'-8" x 7'-4"	"
G	2'-6" x 7'-4"	"
H	3'-0" x 7'-4"	See Det.



FIRST FLOOR PLAN
 Scale 1/4" = 1'-0"

Continue drain to brook

DOOR SCHEDULE

J	2-10" x 7-4" x 1 1/4"
K	2-8" x 7-4" x 1 1/4"
L	2-6" x 7-4" x 1 1/4"

One Panel (See Detail)

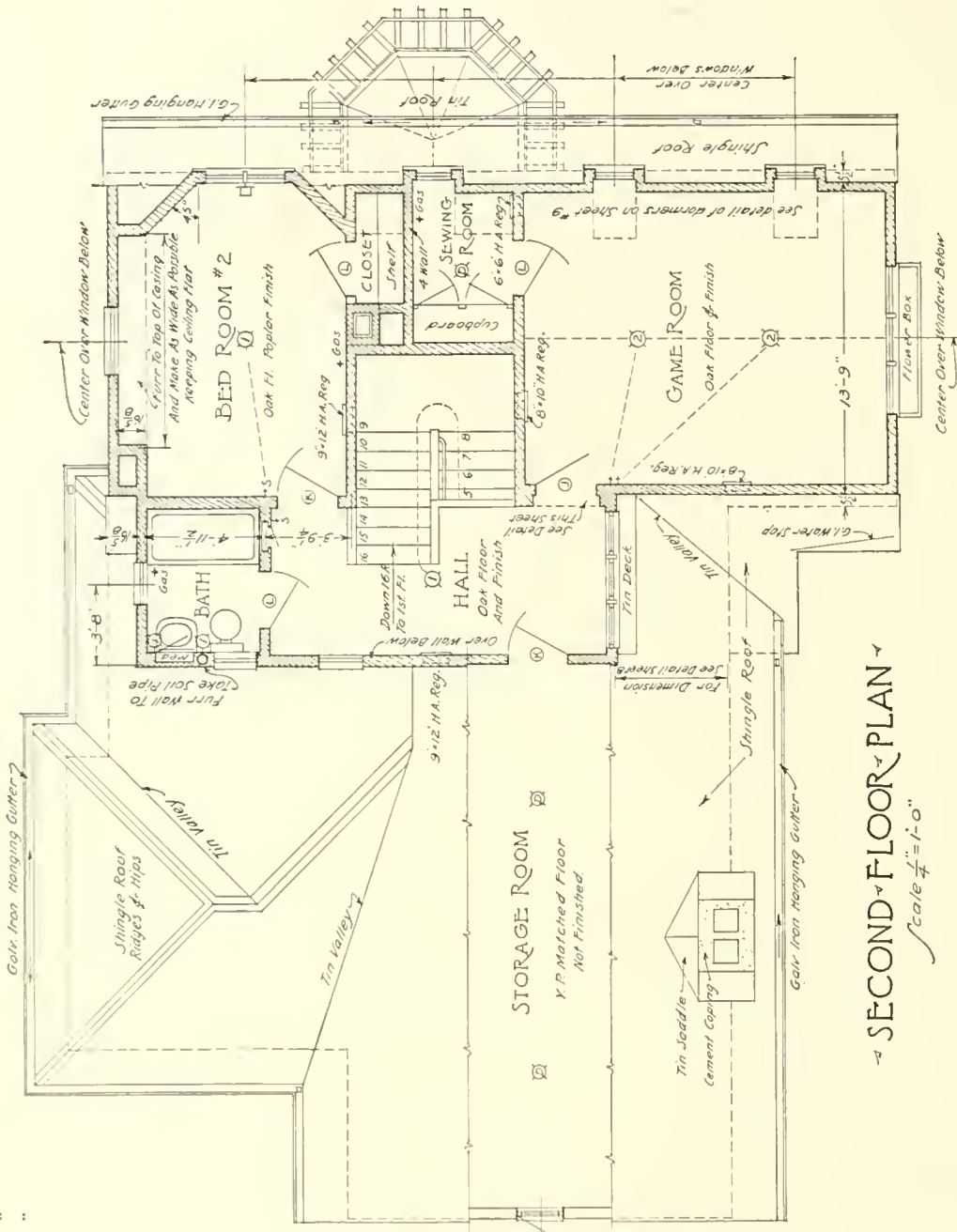
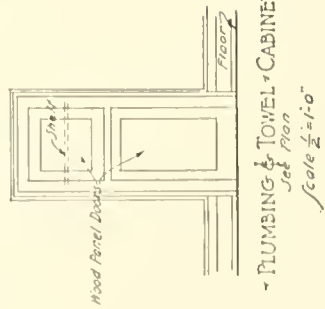
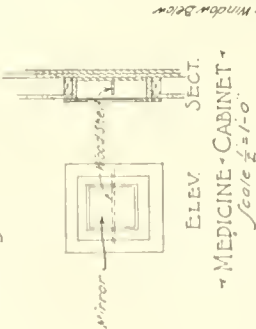
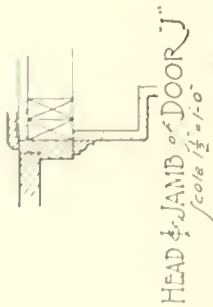

THE HOUSE OF
 MR. RAE - E. COCHRAN -
 GLENCO ROAD - DOMINION PARK -
 COLUMBUS, OHIO.
 WOOSTER BARD FIELD ARCHT.
 COLUMBUS, OHIO.

MAY 31 1919

SHEET 3

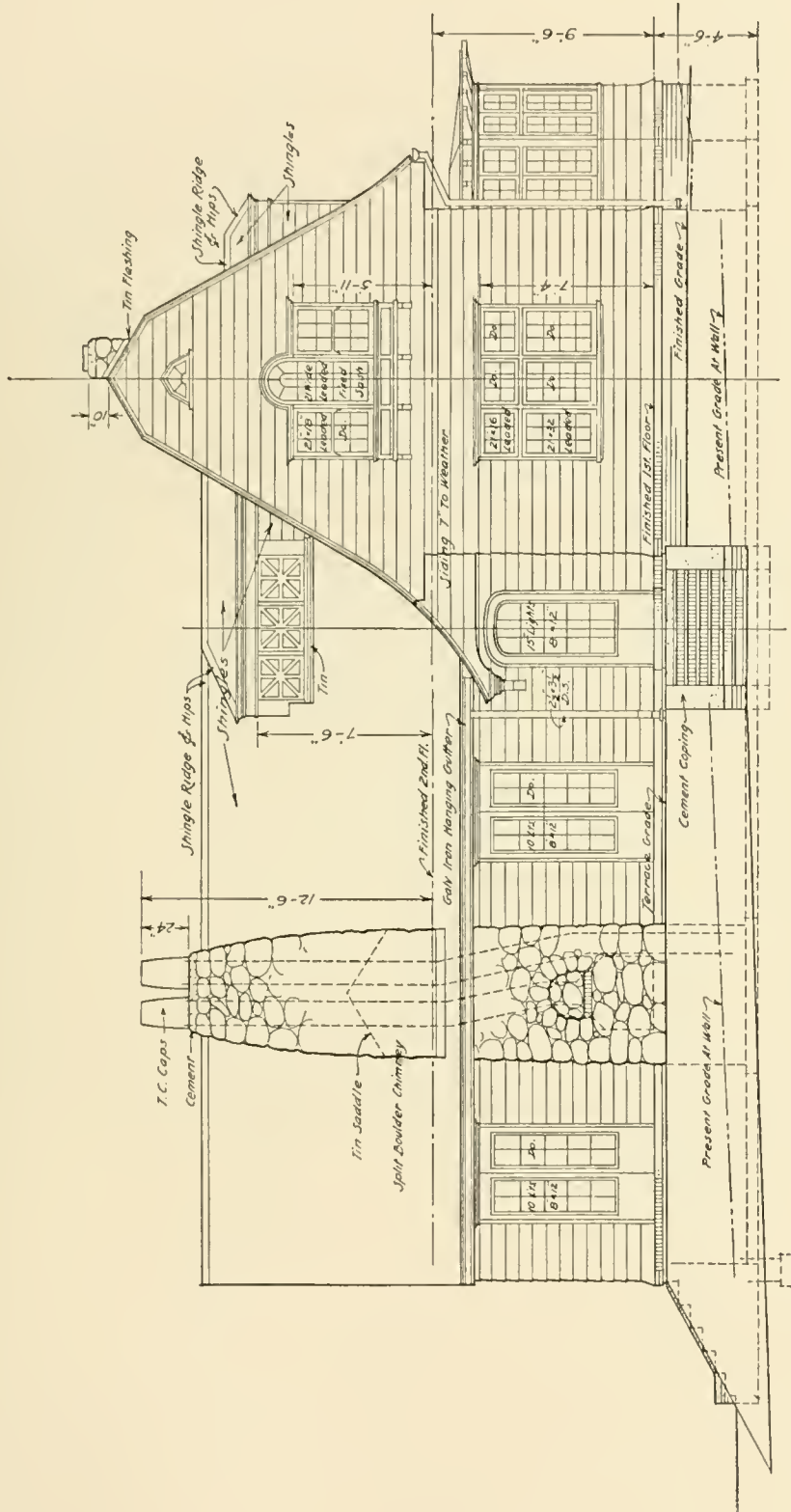

EAST ELEVATION
Scale 1/4" = 1'-0"

SHEET

4

THE HOUSE OF
MR. RAE & E. COCHRAN
- GLENCO - ROAD - DOMINION - PARKS -
- COLUMBUS - OHIO -
WOOSTER - BARD - FIELD - ARCHT.
- COLUMBUS - OHIO -

MAY
31
1919

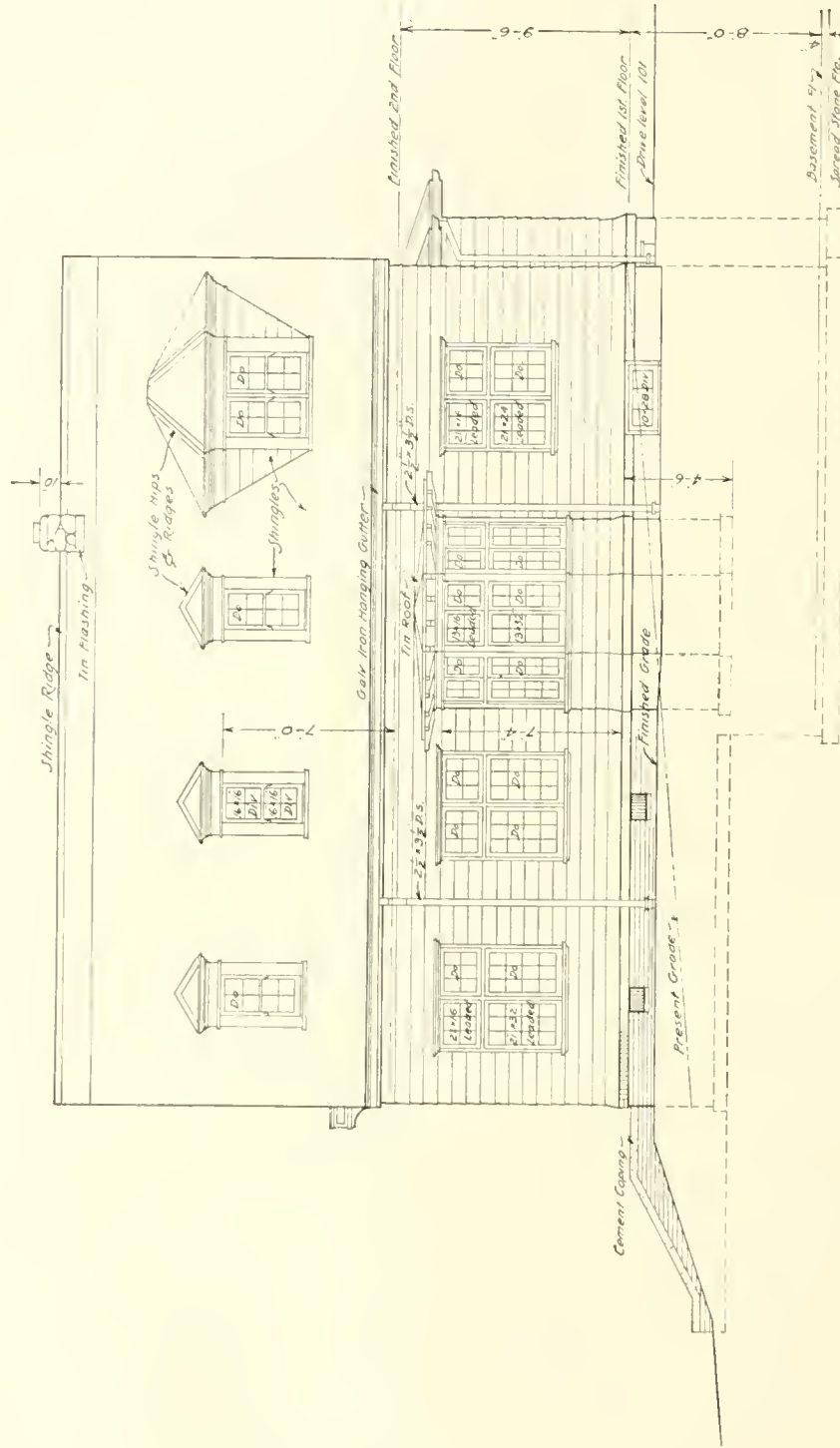

NORTH ELEVATION
Scale $\frac{1}{4} = 1-0$

THE HOUSE OF
 MR. RAE & E. COCHRAN
 GLENCO ROAD, DOMINION PARK
 COLUMBUS, OHIO
 WOOSTER, BARD, FIELD, ARCHT.
 COLUMBUS, OHIO

MAY
 31
 1919

SHEET
 5

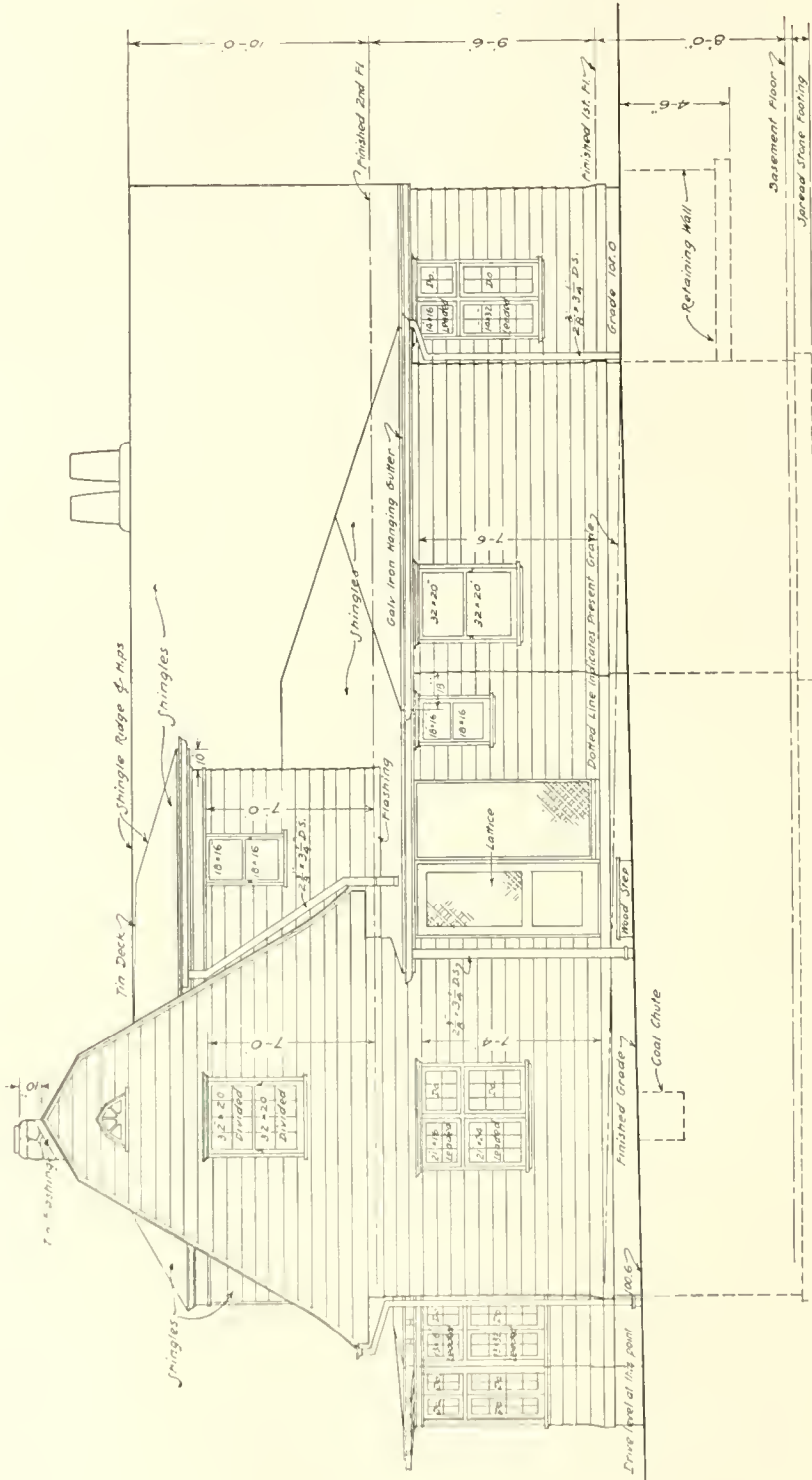

WEST ELEVATION
 Scale 1/4" = 1'-0"

SHEET 7

THE HOUSE OF
 MR. RAE & E. COCHRAN
 GLENCO ROAD - DOMINION PARK -
 COLUMBUS - OHIO.
 WOOSTER BARD FIELD ARCHT -
 COLUMBUS - OHIO.

MAY 31 1919

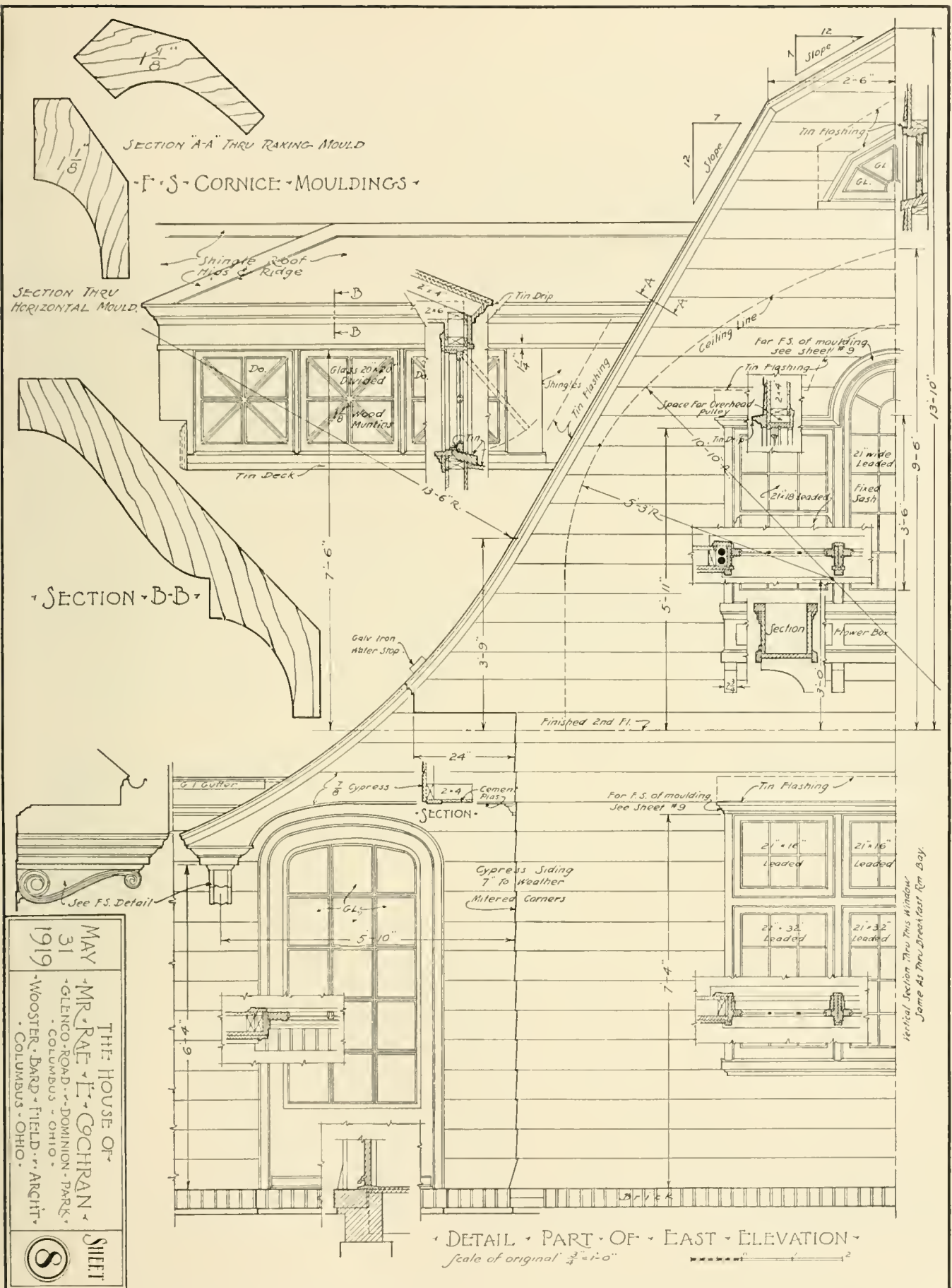

MAY 31 1919
 THE HOUSE OF
 MR. RAE - E. COCHRAN
 - GLENGO - ROAD - DOMINION - PARK -
 - COLUMBUS - OHIO -
 - WOOSTER - BARD - FIELD - ARCHT -
 - COLUMBUS - OHIO -
 SHEET 8

DETAIL PART OF EAST ELEVATION
 scale of original 3/4" = 1'-0"

Vertical Section Thru This Window
 Same As Thru Breakfast Room Bay

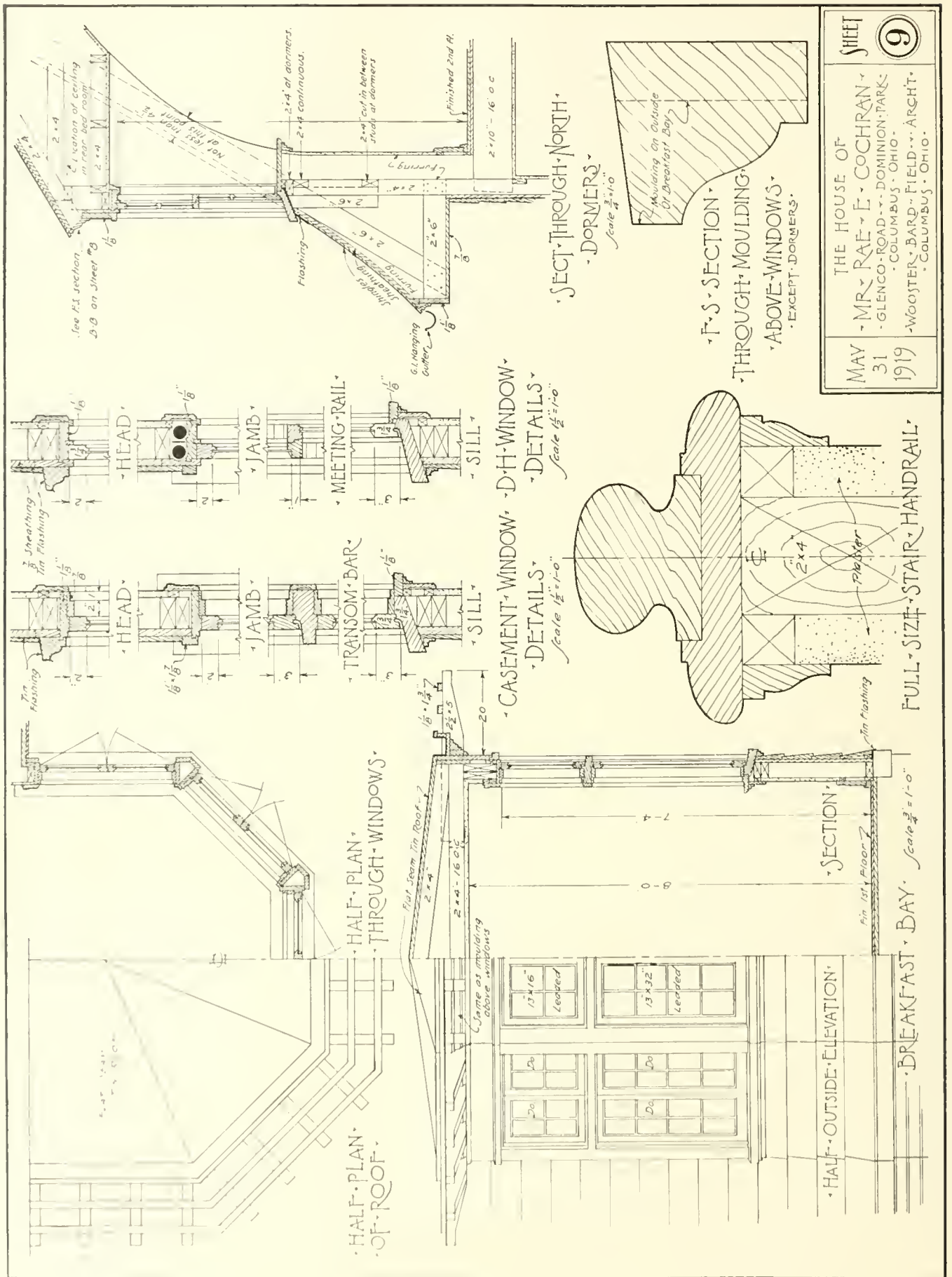

THE HOUSE OF
 MR. RAE & E. COCHRAN
 GLENCO ROAD, DOMINION PARK,
 COLUMBUS, OHIO.
 WOOSTER BARD FIELD ARCHT.
 COLUMBUS, OHIO.

MAY 31 1919

SHEET 9

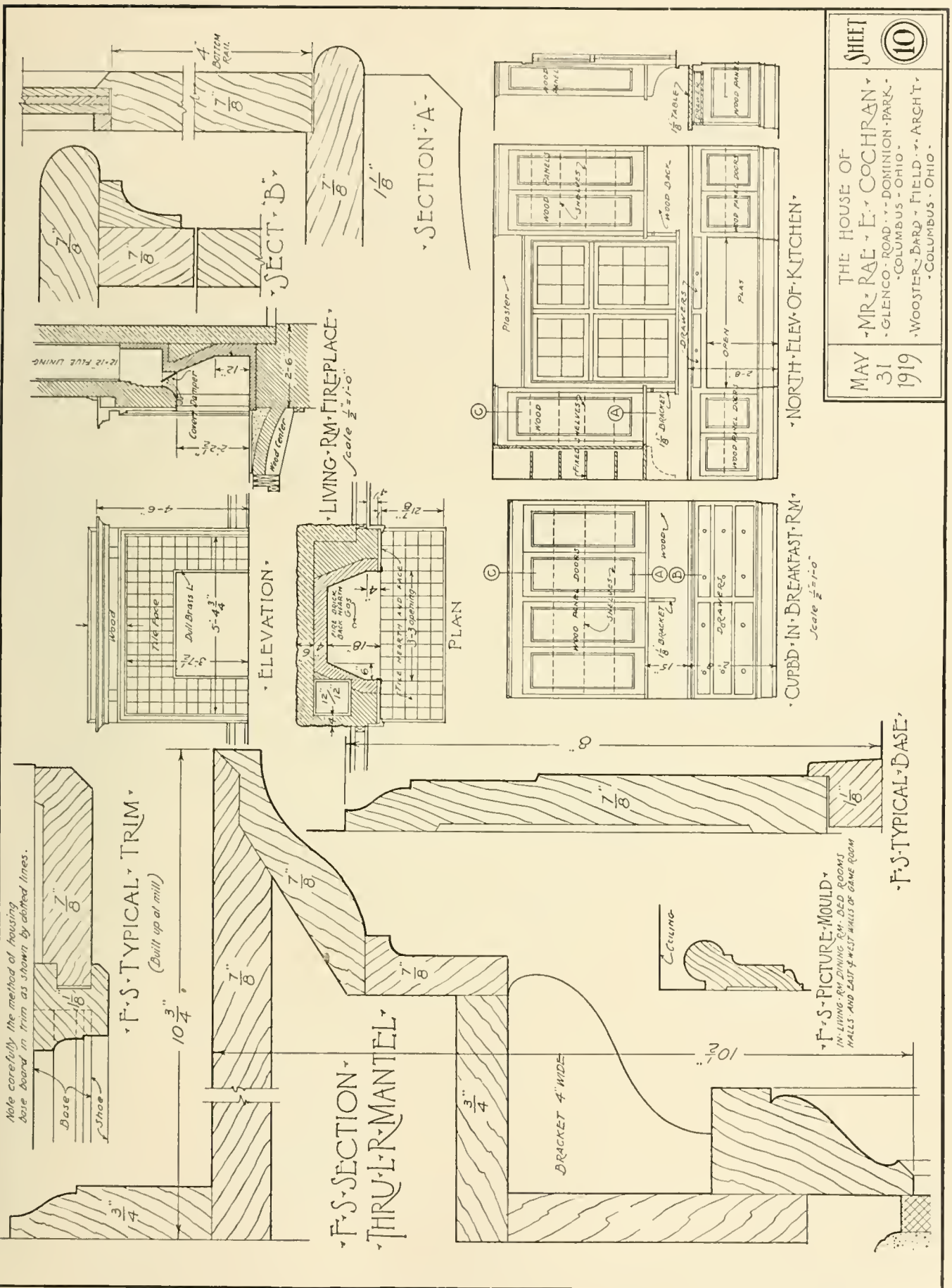

THE HOUSE OF
 MR. RAE & E. COCHRAN
 GLENCO ROAD, DOMINION PARK
 COLUMBUS, OHIO
 WOOSTER, BARD FIELD, ARCH'T.
 COLUMBUS, OHIO

MAY 31 1919

SHEET 10

SURVEY OF SITE.
GRACE METHODIST CHURCH.
SALEM AVENUE & HARVARD BOULEVARD.
DAYTON, OHIO.
N.J.B.

REVISED - OCT. 15, 20

[Redrawn from the plans of]
SCRECK & WILLIAMS - ARCHTS.
DAYTON - OHIO

[SCALE OF ORIGINAL DRAWING -]
1/16" = 1'-0"

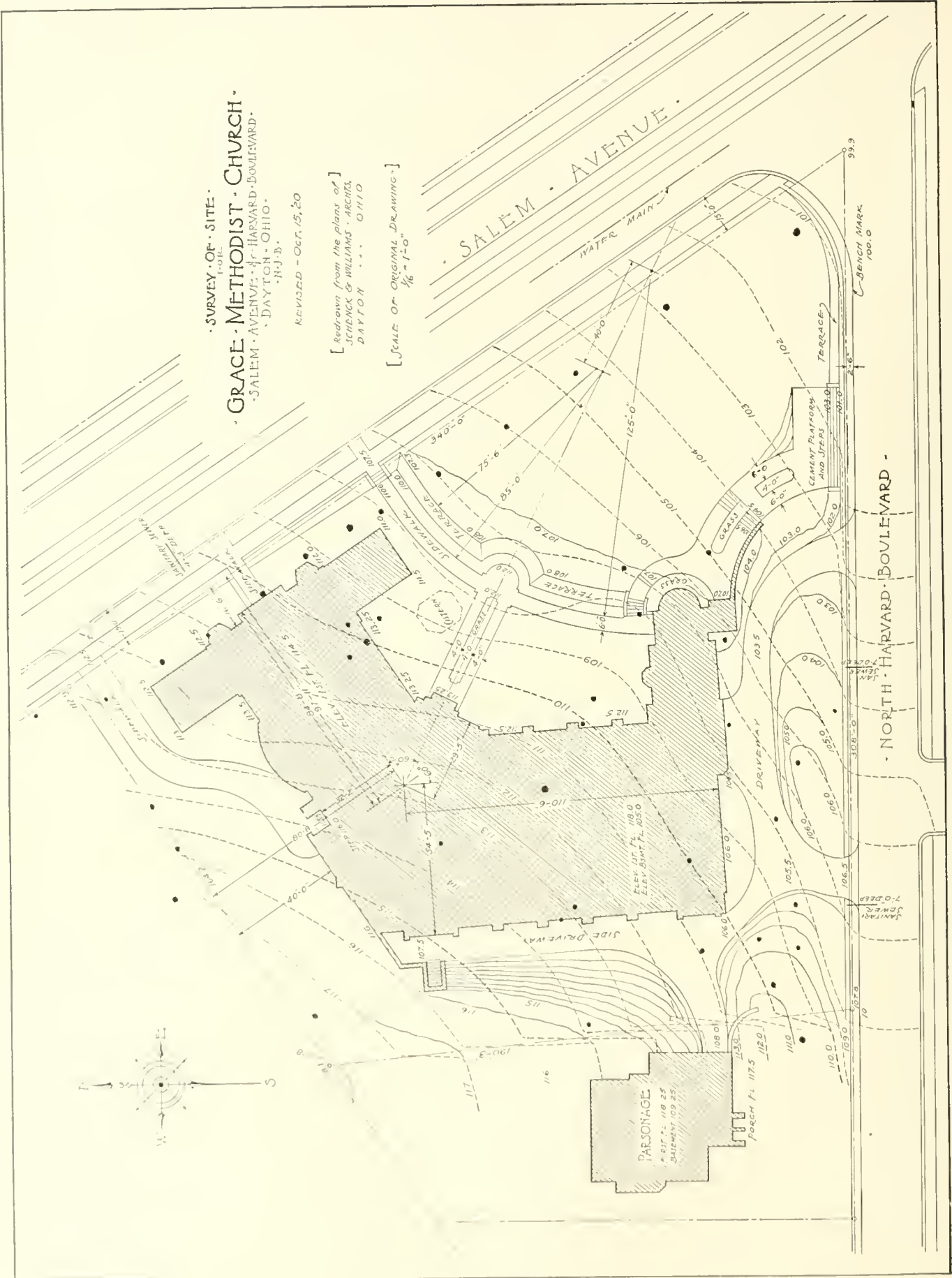

Contour Map or Site Plan.—When it is necessary to design a building for a site that is not level, the architect must know just how high each point is above the lowest part of the site. This information is obtained by the surveyor and presented in a manner similar to that shown on **Plate 31**, which without the building, is called a contour map.

By way of an explanation of this map, imagine a flooded condition of the neighborhood in which the water is gradually rising. The part of the lot first covered by the water would be that at the corner of Salem Avenue and North Harvard Boulevard. Here the shore line would follow the dotted line figured *101*. After the water had risen 4 feet more the shore line would follow the dotted line *105* and the water would have almost reached the location of the building. Thus it will be seen that each dotted line represents points of the same level across the lot.

Notice on the curb near the street intersection the *bench mark* which is figured *100*. This is always established on some fixed object and the various levels measured from it by means of an instrument called a surveyor's level.

Notice now the note on the plan of the building which says that the basement floor elevation is *105.0*. This means that the basement floor is to be $5' - 0''$ above the bench mark. Thus all levels of the building and site are measured from this fixed elevation.

The contour map is valuable in that it tells the architect (after he has located the building upon it) just how far below the first floor the ground is at any point around the building. This information is necessary in the placing of doorways, windows, steps, etc., in the outside wall at the ground level. It is also useful in determining the amount of excavating which must be done for the basement, and the fill for grading outside, when the building has been completed.

The given site plan shows also the location of the existing trees and their approximate size. They are indicated by the spots on the drawing and are sometimes noted as to kind and size.

Location and depth of sewers and location of the water main are also shown.

The points of the compass are given on the map when they are needed.

The lines showing the original contour of the lot are shown on this map by dotted lines and the future or proposed grade is shown by solid freehand lines.

Dimensions of the lot and location of the building on it are also given.

FIRST FLOOR PLAN
OF
GRACE METHODIST CHURCH
SALEM AVENUE - HARVARD BOULEVARD
DAYTON, OHIO

[Redrawn from the plans of]
SCHEMCA & WILLIAMS - ARCHTS
DAYTON, OHIO
[SCALE OF ORIGINAL DRAWING]
5'-10"

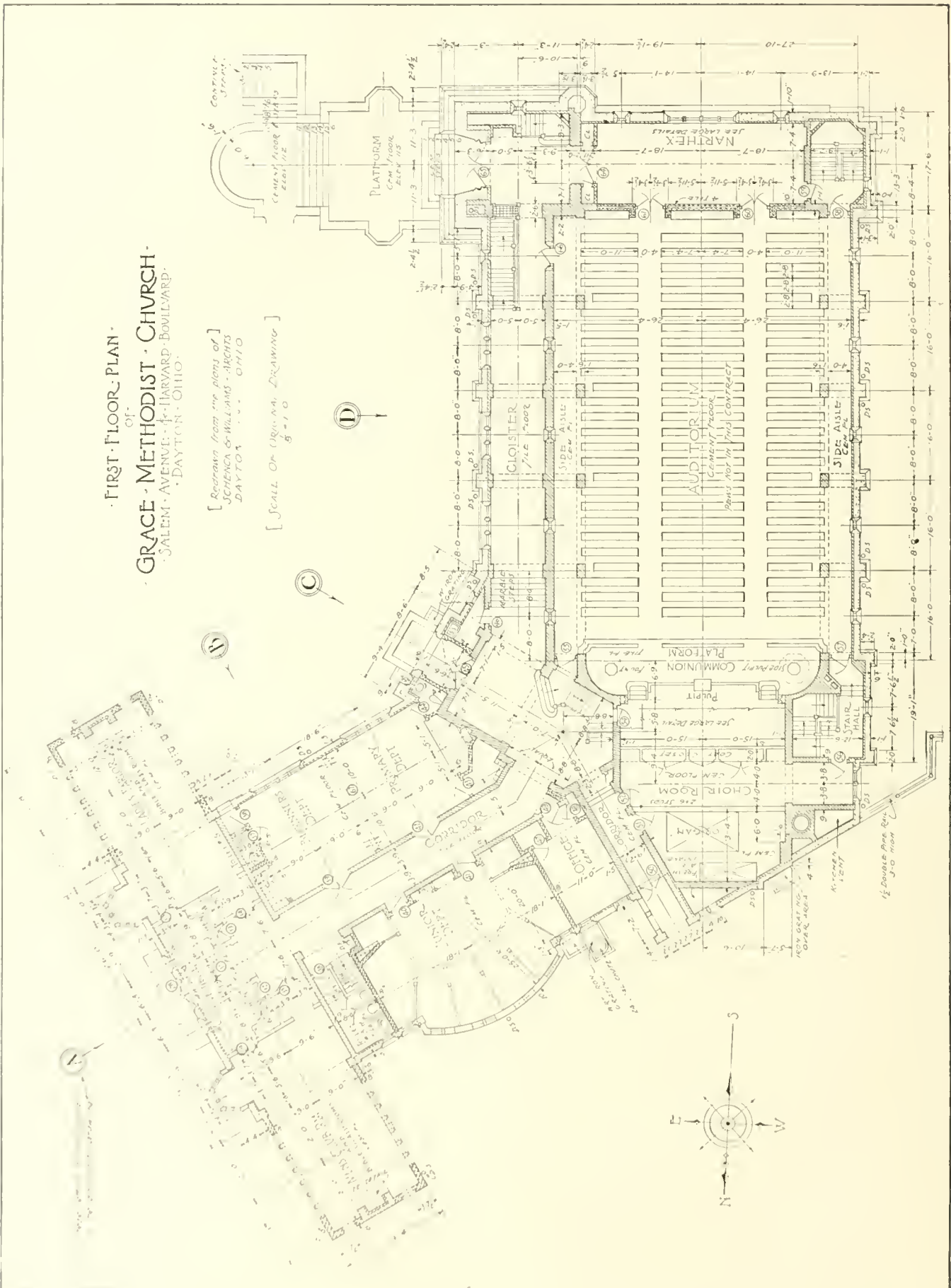

An Irregular Plan.—The opposite plan of the Grace Methodist Church which is called a *general floor plan*, has been given to illustrate the method of laying out an irregular building and to show the indication of stone, brick, structural tile and wood on a plan.

It should be noticed first that everything has been located from the central point near the change in direction of the plan and that all main dimensions are given to center lines radiating from this point.

Now identify the walls that are entirely of brick, then those of stone with brick backing and then the tile and the frame walls. Check them with the schedule of material on **Plate 19**.

Nothing can or need be shown in detail at this small scale, each door, window, etc., being represented by a symbol and detailed at a larger scale on other drawings.

The large letters in the circles are not a part of the drawing but will be referred to when studying **Plate 34**.

Plan of Concrete and Tile Floor Systems.—Plate 33 illustrates the draftsman's method of presenting the structural plan in the main floor of the church.

The Sunday School wing has floors of *concrete slabs* while the auditorium floor is a *combination system* made up of a large number of concrete joist between which are fillers of hollow structural tile block, the latter system being used for the longer spans.

In drawing a plan for the concrete slab floor, notice that the bearing walls below are shown by dotted lines and the outlines of the slabs are solid lines. Then the slab thickness and the size, section and spacing of the steel reinforcing rods are noted on each slab. Where the slab is supported by a beam, the beam is shown dotted on the plan and its number is noted *B-8, B-9, etc.*

The figures in the small rectangles give the elevation of the slab top above the bench mark on the curb at the street intersection. These elevations are noted at all points of the plan, for the top of each slab must come exactly to the proper level.

The plan of the combination floor system shows the supporting walls and beams dotted as before and each concrete joist of the floor indicated by solid lines.

Notice that the center part of the main floor is made up of 71 units as shown in the detailed section above the plan on this plate, each unit having a tile filler 12 inches wide and a concrete joist 4 inches wide. The note (*6" Tile — 2" Conc.*) means tile 6 inches in depth with 2 inches of concrete on top of it as shown in the detail marked *J-A, J-B.*

On this plate is given also a typical schedule or list of the size of the concrete girders, beams and joist, and a description of the steel reinforcement in each.



SALEM - AVE - ELEVATION - OF - S - S - WING -

[THIS ELEVATION IS TAKEN AS THOUGH THE OBSERVER WERE STANDING AT POSITION (A) AS SHOWN ON THE FIRST FLOOR PLAN AND LOOKING IN THE DIRECTION INDICATED BY THE ARROW.]



- EAST - ELEVATION

[THIS ELEVATION IS TAKEN FROM POSITION (1) AS SHOWN ON THE FIRST FLOOR PLAN AND LOOKING IN THE DIRECTION INDICATED BY THE ARROW. THE VIEW OF THE BUILDING FROM THE WINDOW IS NOT IN A LINE WITH THE WINDOW BUT IS TAKEN AT AN ANGLE OF 120° WITH THE ABOVE VIEW AND WOULD BE DISTORTED IF VIEWED FROM THIS DIRECTION]

- GRACE - METHODIST - CHURCH -
 • SALEM - AVENUE - & - HARVARD - BOULEVARD -
 • DAYTON - OHIO -

[DRAWN FROM THE WORK OF]
 SHEPHERD W. WELLS - ARCHT.
 DAYTON - OHIO

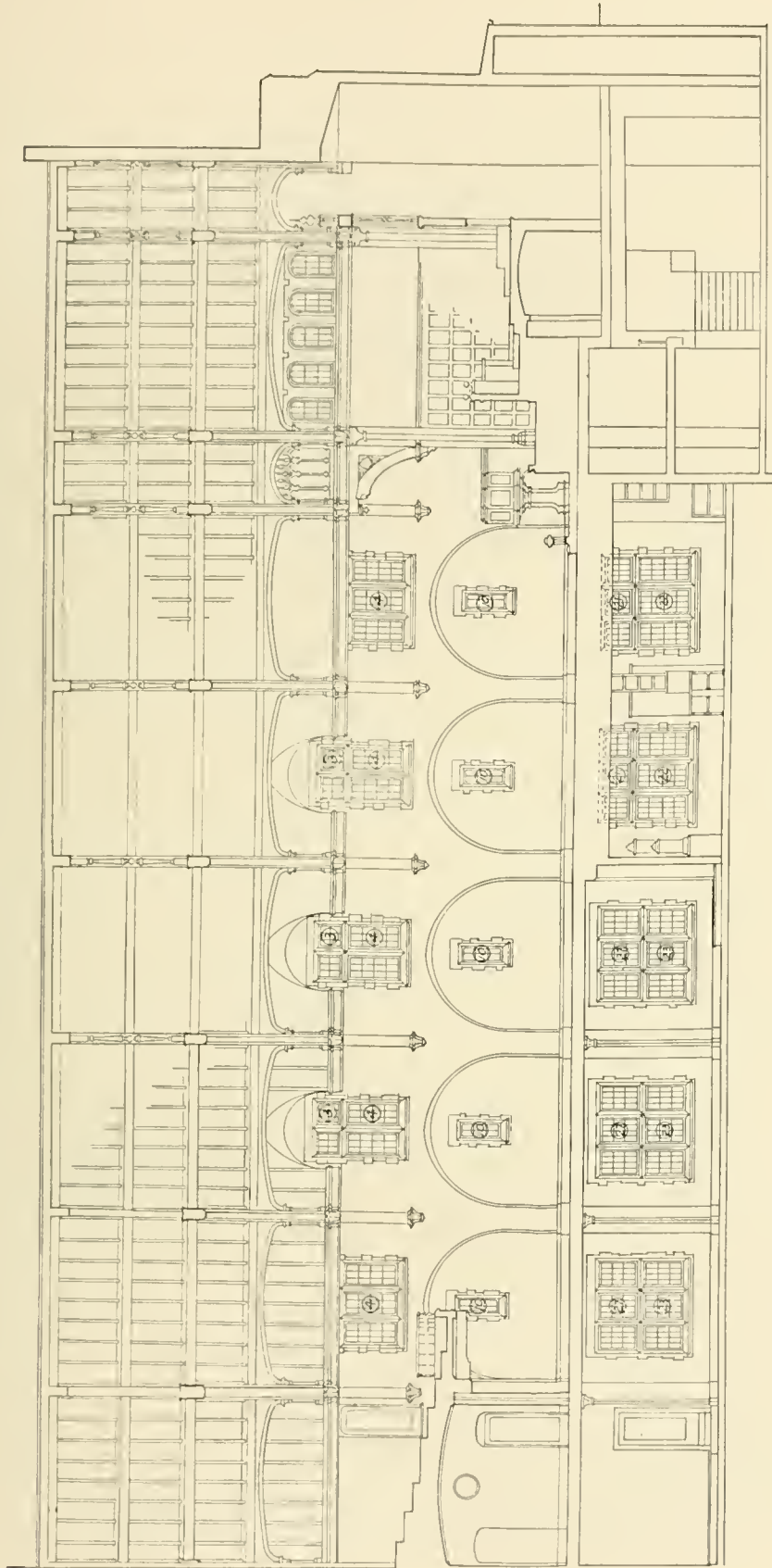

LONGITUDINAL SECTION THRU AUDITORIUM

[Scale of Original Drawing $\frac{1}{8} = 1'-0"$]

[SECTIONS SIMILAR TO THE ABOVE ARE MADE TO GIVE A COMPREHENSIVE VIEW OF THE INTERIOR. THEY SHOW EACH FEATURE IN PROPER RELATION TO THE OTHERS AND TO THE WHOLE, BUT DESCRIBE NOTHING IN DETAIL. THUS THE GIVEN SECTION SHOWS THE DISPOSITION OF TRUSSES & OTHER ROOF MEMBERS & THE LOCATION OF FLOORS WINDOWS, PLASTER ARCHES, VAULTS ETC. PROPERLY PLACED IN THE SCHEME. WHEREVER ANY PART HAS BEEN CUT DIRECTLY THRU AS THE ROOF, TRUSS MEMBERS, BALCONY, FLOORS, ETC., A SLIGHTLY HEAVIER OUTLINE AROUND THAT PART WILL ADD TO THE LEGIBILITY OF THE DRAWING. NO DIMENSIONS NEED BE GIVEN ON SUCH A SECTION BECAUSE EACH FEATURE IS DESCRIBED IN DETAIL BY DRAWINGS MADE AT A LARGER SCALE.]

AUDITORIUM
OF
GRACE METHODIST CHURCH
SALEM AVENUE & HARVARD BOULEVARD
DAYTON OHIO.

[Redrawn from the plans of]
JACOBUS & WILLIAMS ARCHT
DAYTON OHIO

DETAILS
OF
GRACE-METHODIST-CHURCH
SALIM AVENUE HARVARD BOULEVARD
DAYTON OHIO

[Redrawn from the plans of]
JENCKEN & WILLIAMS ARCHTS
DAYTON, OHIO

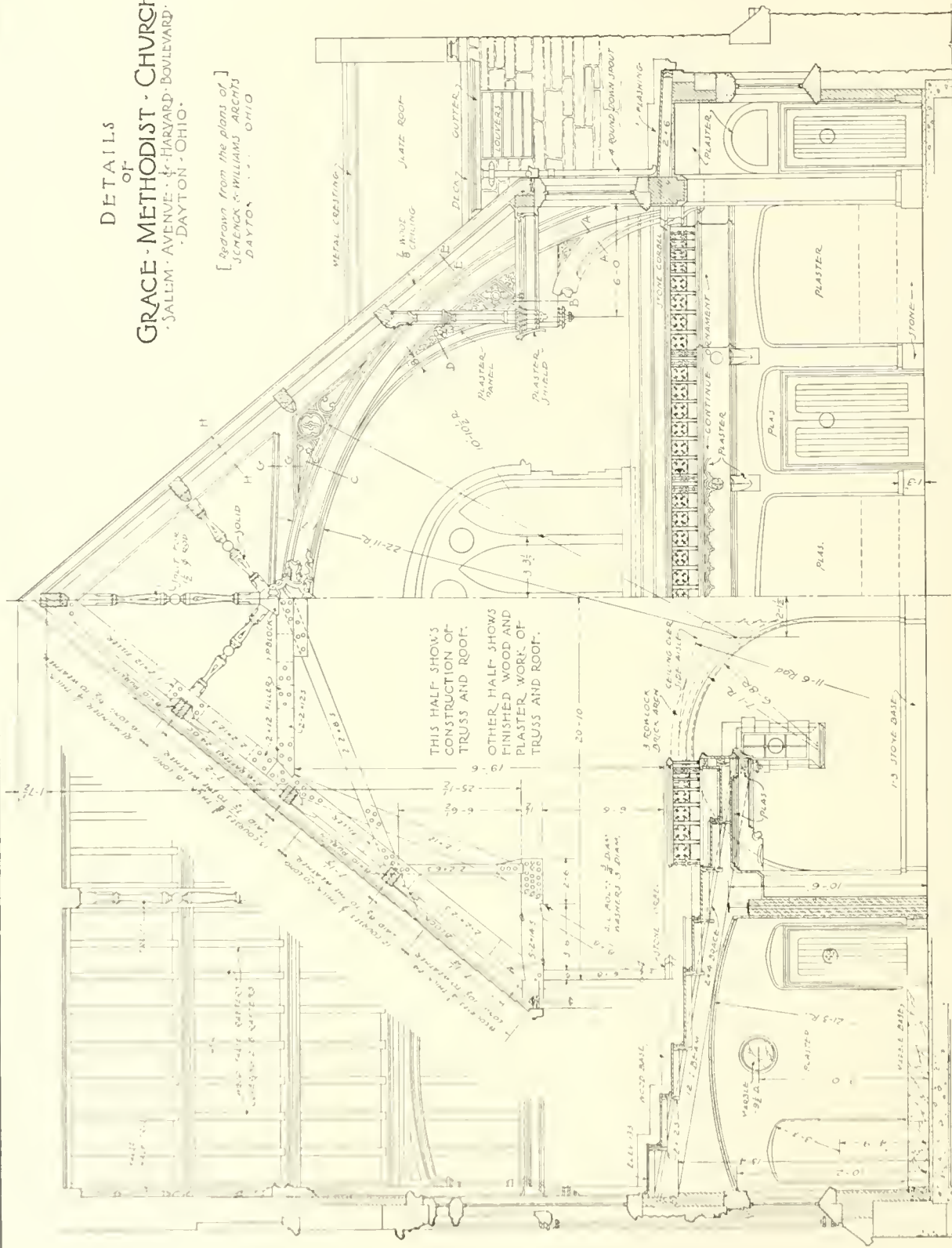

THIS HALF SHOWS
CONSTRUCTION OF
TRUSS AND ROOF.
OTHER HALF SHOWS
FINISHED WOOD AND
PLASTER WORK OF
TRUSS AND ROOF.

SECTION THRU NARTHEX AND BALCONY

HALF CROSS SECTION OF MAIN AUDITORIUM
[SCALE OF ORIGINAL DRAWING 1/8"=1'-0"]

ARCHITECTURAL DRAWING

Plate 34 will give an idea as to the presentation of the elevation of a building whose walls are built of roughly-faced stone laid up in what is known as rock face broken ashlar. On an elevation showing this kind of masonry, only enough of the stone joints are drawn to show the approximate size of the stones and about how they are to be laid up. Where cut stone is used as around the windows and doors, each stone should be drawn.

Every opening has a number, and where the feature in the opening is rather complicated, as the main door 65 or the tracery in the tower, it may be omitted from the small scale elevation entirely but shown on the larger scale details.

A note on the plate explains how the elevations there shown are taken.

The two ends of the Sunday School wing and the bay over the entrance door show the manner of indicating stucco walls with imitation half-timber construction.

Notice on these drawings that the elevations of the bottom of the foundation walls are noted as are also those of the finished grade and the floor levels. These elevations as well as those on the contour map are measured from the bench mark on the curb stone.

On **Plate 36** is a typical scale detail of the interior of the church auditorium. Here the draftsman has taken three drawings and so combined them as to save space and, at the same time, show the different views of each feature in close proximity.

The center part of the drawing gives a transverse section through the auditorium taken near and looking toward the south entrance doors. The right half of this shows in detail the plaster and wood finish on the roof trusses, the ornamental balcony rail and plaster balcony ornament. It also gives in more detail the wall and floor construction and the roof of the side aisles. The structural or working part of the roof truss is shown to the left of the center line as is also the structural detail of the roof itself, thus showing the relation between structure and finish.

At the extreme left of the sheet is a section through the center of the balcony over the narthex (check with **Plate 32**) and through a part of the south or front wall of the church. This drawing is made to show in detail the construction of the balcony and the elevation of the west wall in the narthex. It also details the arches at the side aisles.

Several such drawings are necessary for the description of a building so complex as this one.

When the building is so large as to necessitate the drawing of the elevations at a small scale as shown on **Plate 34**, it then becomes necessary to draw portions of the elevation at a larger scale so as to describe its parts adequately. **Plate 37** gives a scale detail describing a part of the south wall of the church. This shows accurately the shape, size and location of all features of this part of the wall. It locates vertically all windows, doors and other openings. The cut stone parts are accurately drawn and dimensioned as shown, all cut stone joints being located. The approximate size of the stones and general character of the ashlar walls is here indicated in a manner easily distinguished from the cut stone work.

Notice that vertical dimensions are given from the main floor level and the elevation of this floor (118.0) is noted. Attention is called also to the method of dimensioning the batter or slope of the tower wall.

The tower stair, which is built against this wall, is indicated by dotted lines and the risers are numbered for convenience in reading the drawing.

Enough scale details of this kind are drawn to describe all of the outside walls.

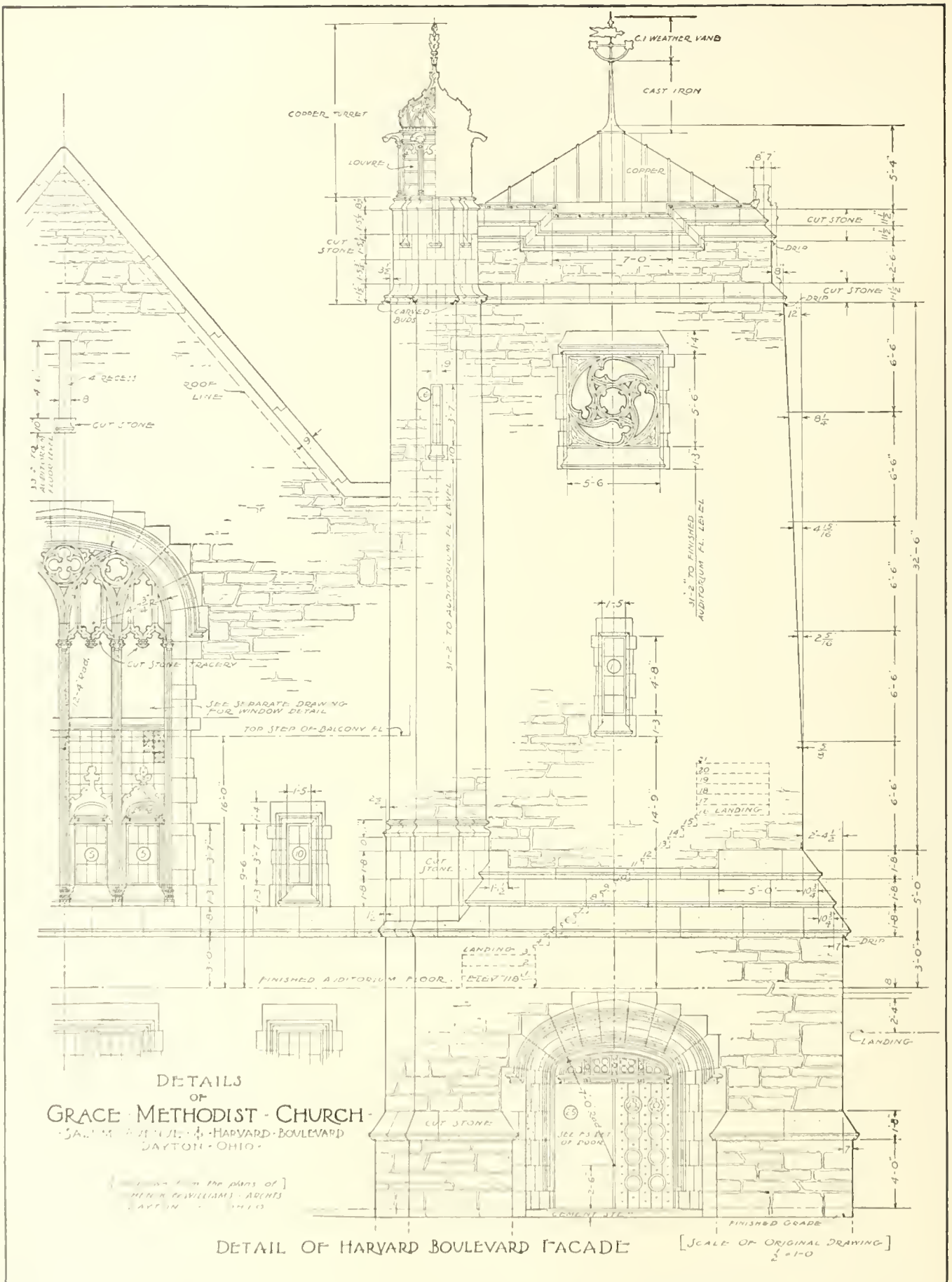

DETAILS
OF
GRACE METHODIST CHURCH
- 521 W. 4TH ST. - HARVARD BOULEVARD
DAYTON - OHIO -

Drawn from the plans of
HENRY WILLIAMS - ARCHT.
MAY 1913

DETAIL OF HARVARD BOULEVARD FACADE

[SCALE OF ORIGINAL DRAWING]
1/2" = 1'-0"

DETAILS
OF
GRACE METHODIST CHURCH
SALEM AVENUE & HARVARD BOULEVARD
DAYTON OHIO

[Redrawn from the plans of]
SCHENCK & WILLIAMS ARCHTS
DAYTON OHIO

[THIS SECTION IS TAKEN THRU THE TOWER ON THE CENTER LINE AS THOUGH THE OBSERVER WERE LOOKING WEST.

THE ORIGINAL DRAWINGS CONTAIN IN ADDITION TO THIS ONE A SECTION THRU THE CENTER OF THE TOWER AND LOOKING NORTH. THESE TWO TOWER SECTIONS TOGETHER WITH THE DETAIL ELEVATIONS AFFORD A COMPLETE DESCRIPTION OF THE SOUTH AND EAST WALLS GIVING LOCATION AND DEPTH OF CUT STONE COURSES AND ASHLAR WALLS AND SHOWING THE POSITION OF BRICK BACKING IN THE WALLS. THE FLOOR CONSTRUCTION ALSO IS SHOWN AND ELEVATIONS OF THE INSIDE WALLS AND OF STAIRS ETC.

FOR PRACTICE IN READING THE DRAWINGS CHECK LOCATION OF DOORS, STAIRS ETC. WITH THOSE SHOWN ON THE AUDITORIUM FLOOR PLAN AND CHECK FLOOR CONSTRUCTION WITH THE FIRST FLOOR FRAMING PLAN.

SINCE THIS DRAWING IS OF NECESSITY MUCH SMALLER THAN THE ARCHITECT'S DETAIL IT IS IMPOSSIBLE TO SHOW THE MOULDINGS, IRON BALUSTRADE ETC. AS ACCURATELY AS ON THE HALF INCH SCALE WORKING DRAWING.

FULL SIZE DETAILS HAVE BEEN MADE FOR ALL OF THE MOULDINGS AND FOR THE ORNAMENTAL IRON WORK.

THIS METHOD OF DETAILING HAS BEEN CARRIED OUT OVER THE ENTIRE BUILDING MAKING THE DRAWINGS VERY COMPLETE AND EASILY INTERPRETED BY THE BUILDER.]

SECTION THRU MAIN TOWER
LOOKING WEST

[SCALE OF ORIGINAL DRAWING]
1/2" = 1'-0"

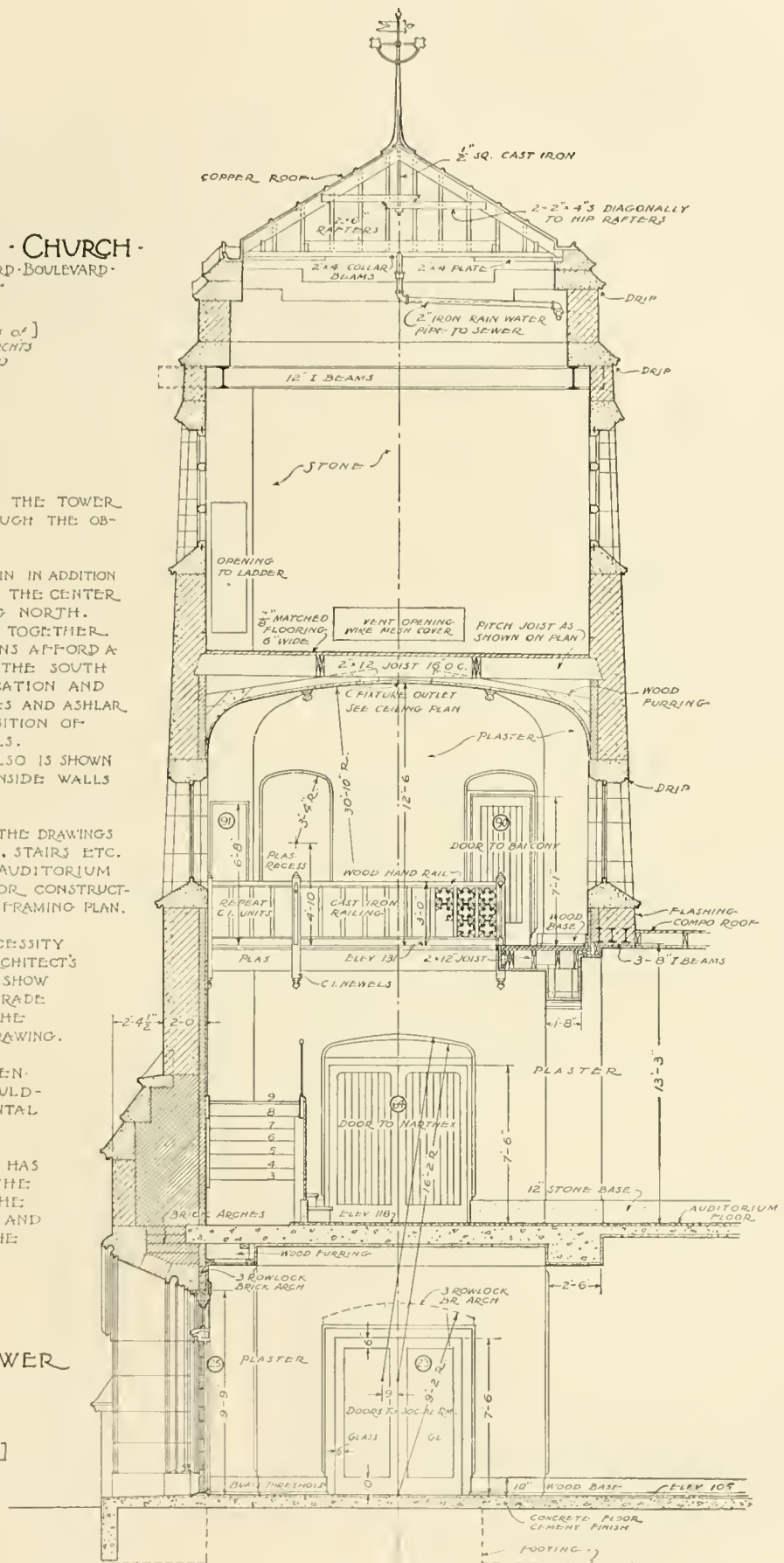

ARCHITECTURAL DRAWING

The lot upon which the Cleveland Discount Building Company's building is located is underlaid for some distance with earth of such a nature that it will not support the excessive weight of a building of this size. The depth to which this soft earth extends is so great as to make it impractical to carry the foundation walls down to the solid footing required. When such a condition is met it is necessary to provide some kind of supports down through the soft material to the solid rock or other good footing. These supports are called *piles* and are long wood or concrete posts. When concrete piles are used, a hollow sheet steel form is driven down as far as necessary and then filled with concrete. Concrete footings are next formed on top of the piling and the building rests on these footings.

It is necessary that each pile be located as accurately as possible and for this purpose a piling plan is made as suggested on **Plate 39**.

Notice that the elevation of the top of the driven piling is marked on each footing. Thus the contractor who drives the piles knows just where to finish off the top of each pile. The footing sections, see *Type-A* and *Type-B*, show how the concrete footings are built on top of the piling. The steel reinforcing rods and the steel girders are shown by solid black lines.

When there are a number of footings of each size and kind, they may be given type numbers or letters as in this case and only one of each type described in detail.

On **Plate 43** is a typical small scale elevation and section of a very large building. The actual elevations of this structure are much larger than those of the Grace Methodist Church and consequently must be shown at a smaller scale so that the sheets may not become too large to handle. This makes it impractical to show so much detail and such drawings are therefore useful only in suggesting the elevation as a whole by simple lines and in giving the main vertical dimensions.

The transverse section shows the banking quarters on the first floor and the rental space and light court above.

Parts of the elevations are then detailed at a larger scale similar to that of the church on **Plate 37**.

Notice that the ornamental metal work and terra cotta is indicated in the simplest possible manner and sometimes only noted.

Plate 44 gives one of a number of large scale details showing the relation of the walls, floors, and ornament to the structural members. It is explained by the note on the plate.

The banking quarters, which are the most important part of the building, are elaborately finished, making necessary a great many details of this part. One of these details is given on **Plate 45** and is typical of such interior elevations. On the first floor plan of **Plate 40** find the point at which this detail was taken, and compare column numbers, stairs, etc.

OFFICE BUILDING
FOR THE
CLEVELAND DISCOUNT BUILDING CO.
CLEVELAND ... OHIO

[Redrawn from the plans of]
WALKER & WEEKS, ARCHTS.
CLEVELAND OHIO
FIRST FLOOR PLAN
[Scale of original drawing]
 $\frac{1}{8} = 1'-0''$

[DUE TO THE SMALL SIZE OF THE PAGE IT IS IMPOSSIBLE TO SHOW THIS PLAN AS ACTUALLY DRAWN BY THE ARCHITECT. FOR MUCH OF THE DETAIL MUST BE OMITTED HERE. THE PARTIAL DRAWING TO THE LEFT IS GIVEN SO THAT THE DRAFTSMAN MAY SEE EXACTLY THE DETAIL WITH WHICH THE ORIGINAL IS WORKED UP. IT IS DRAWN HERE AT THE SCALE OF THE ORIGINAL. THE DRAWING BELOW SHOWS ALL FEATURES OF THE FIRST FLOOR PLAN AND THEIR RELATION TO THE STRUCTURAL COLUMNS AND WALLS. ALL COLUMNS ARE LOCATED BY THEIR CENTER LINES AND FROM THE BUILDING LINE, THEN THE WALLS ETC. ARE LOCATED FROM COLUMN CENTERS.]
THE FURNITURE OF THE BANKING ROOM IS A PART OF THE SCHEME AND AS SUCH IS DESIGNED BY THE ARCHITECT AND INDICATED ON THIS PLAN. THIS INCLUDES THE 'CAGES,' SCREENS, CHECK DESKS ETC.]

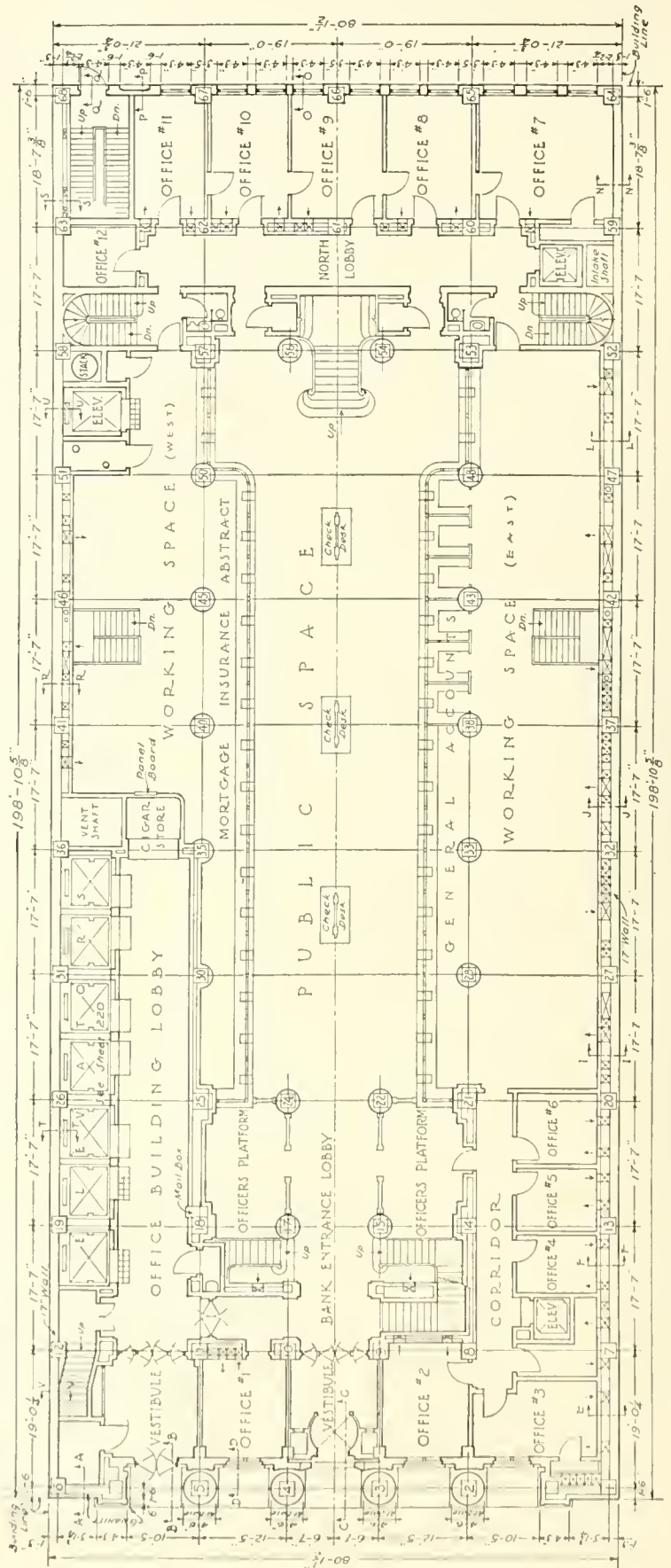
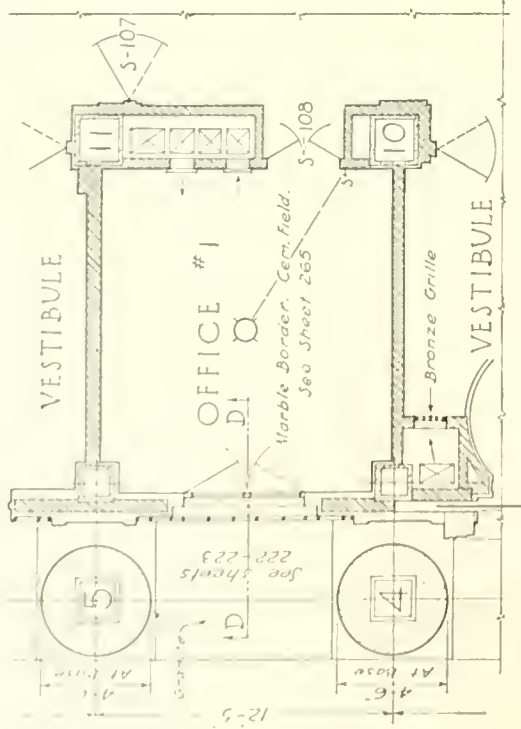

OFFICE BUILDING
FOR THE
CLEVELAND DISCOUNT BUILDING CO.
CLEVELAND... OHIO

[Redrawn from the plans of]
WALKER & WEEKS, ARCHTS.
CLEVELAND, OHIO

TYPICAL FLOOR PLAN [Scale of original drawing]
1/8"=1'-0"

[THE ENTIRE FLOOR PLAN IS SHOWN BELOW, AND A PART OF IT GIVEN AT THE LEFT EXACTLY THE SIZE OF THE ORIGINAL, SO AS TO SHOW THE AMOUNT OF DETAIL WORKED INTO THE ARCHITECT'S DRAWING. NOTICE THAT ELECTRIC LIGHT OUTLETS ARE LOCATED BY DIMENSIONS FROM THE COLUMN CENTER LINES. THE SWITCHES ALSO ARE SHOWN AND NOTED AS ARE ALSO THE WIRING CABINETS, ETC. THE DOORS ARE NUMBERED HERE AND DESCRIBED IN A DOOR SCHEDULE ON ANOTHER SHEET OF THE ORIGINALS. RADIATORS ARE SHOWN AND THEIR SIZE AND AMOUNT OF RADIATION NOTED. THE MATERIAL OF FLOORS, BASES, WAINSCOT ETC. IS NOTED UNLESS ELSEWHERE SHOWN IN A DETAIL.]

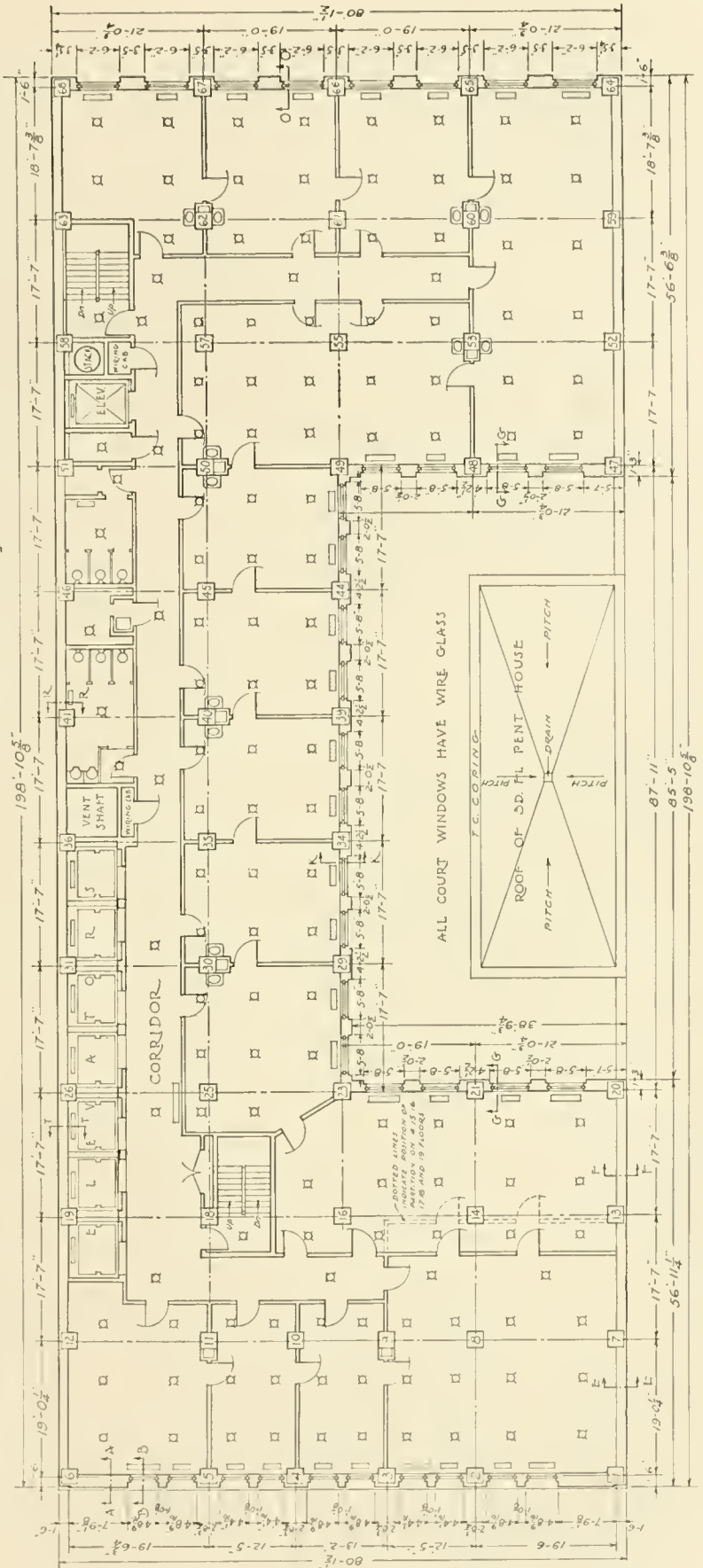
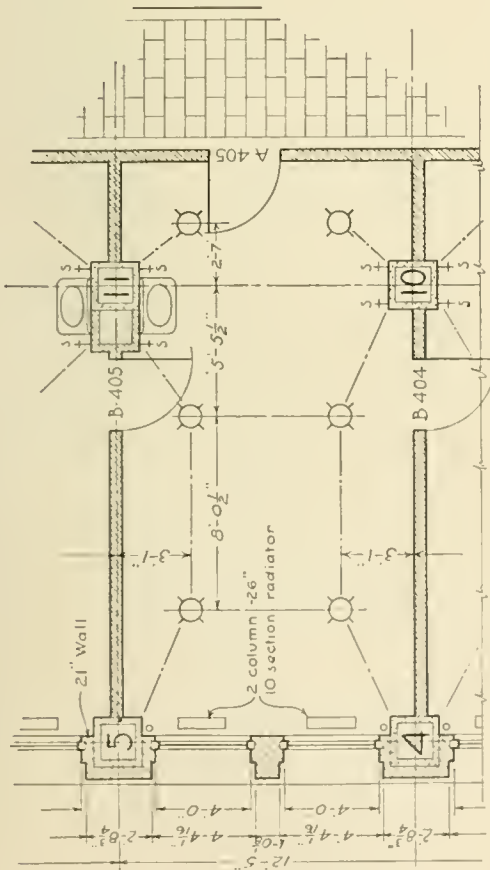

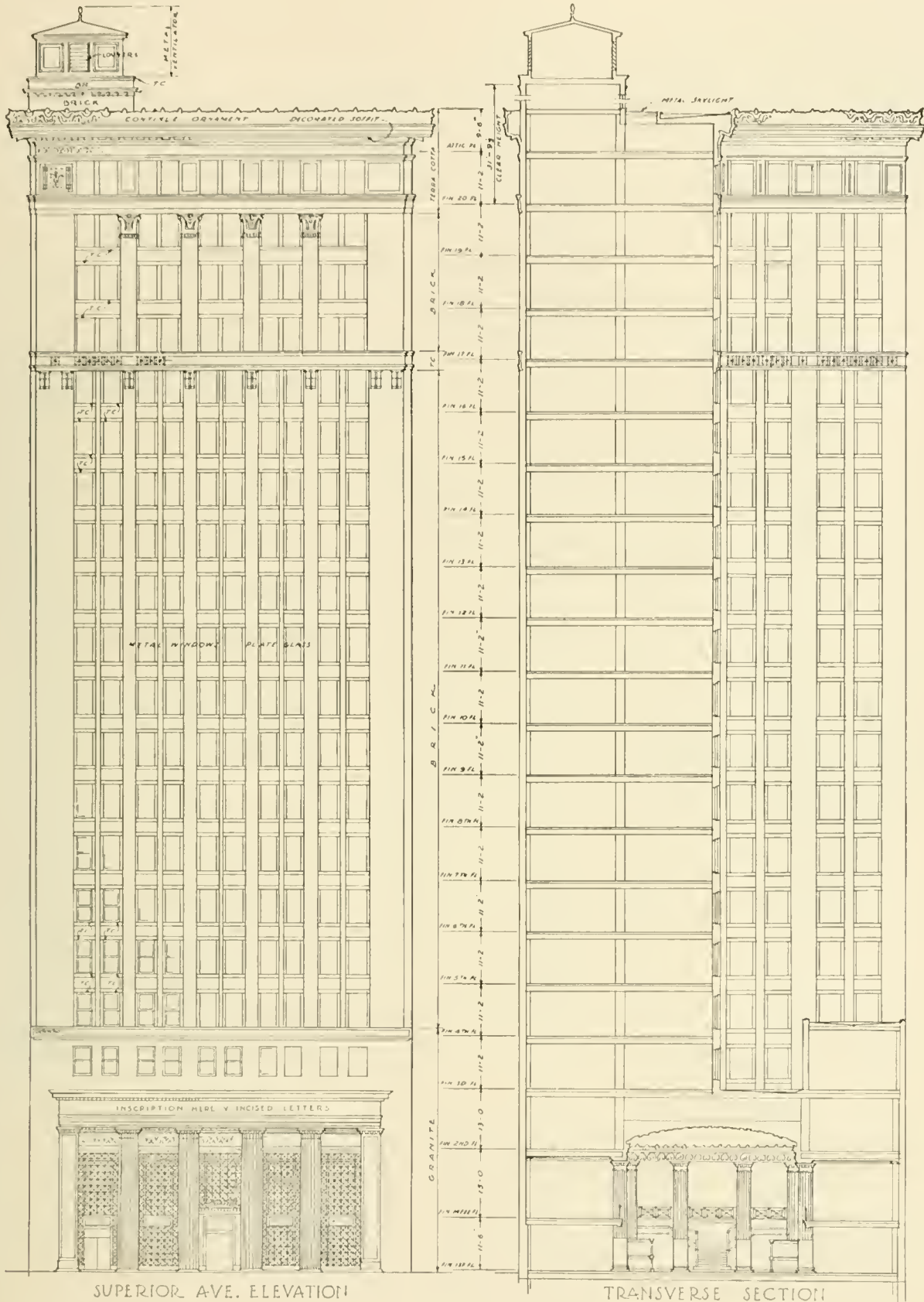

SUPERIOR AVE. ELEVATION

TRANSVERSE SECTION

[Redrawn from the plans of,
WALKER & WEEKS, ARCHTS
CLEVELAND, OHIO

OFFICE BUILDING
FOR THE
CLEVELAND DISCOUNT BUILDING CO.
CLEVELAND --- OHIO

[Scale of original drawing]
 $\frac{1}{16} = 1'-0"$

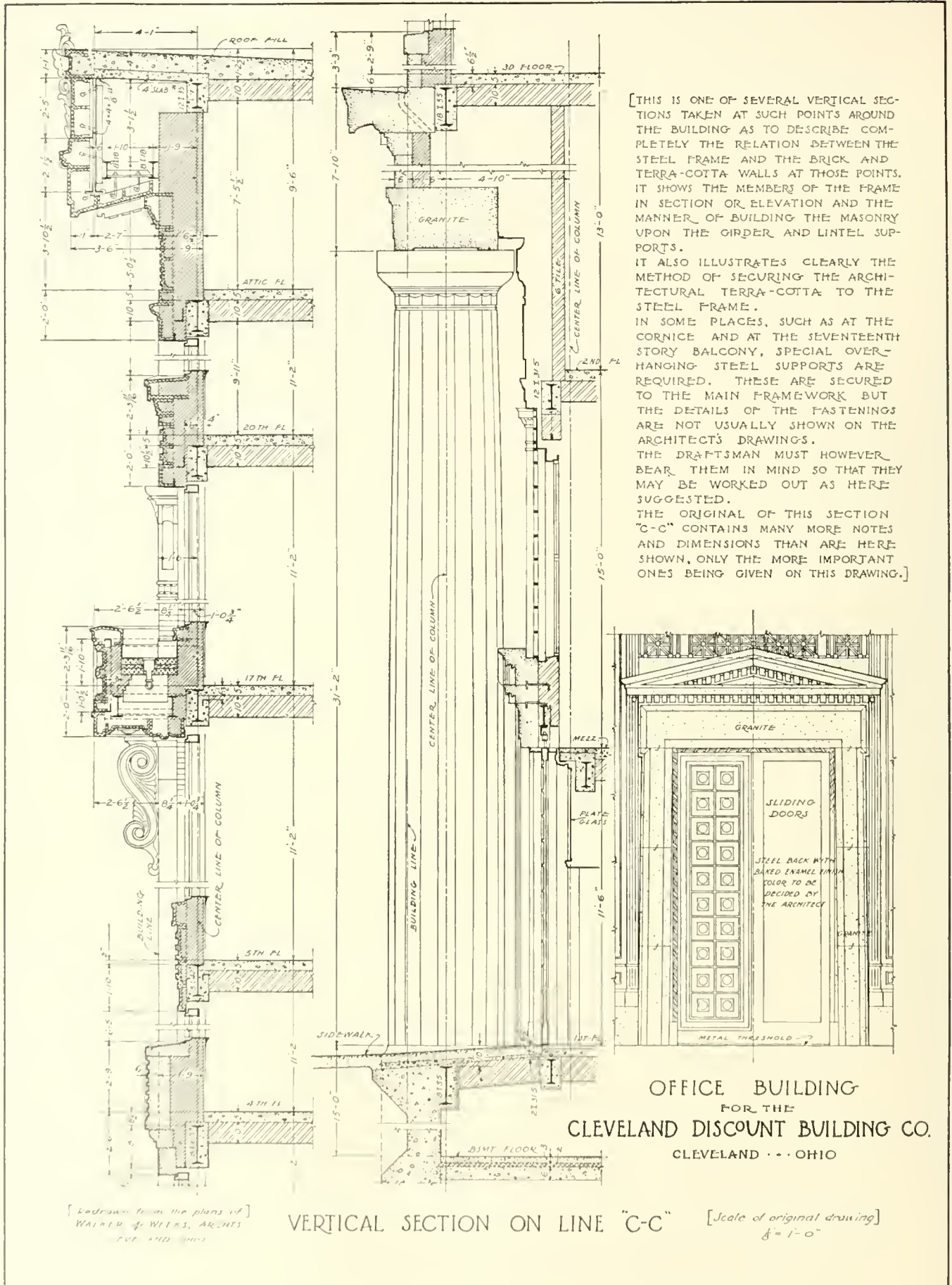

[Redrawn from the plans of]
WALKER & WILKS, ARCHTS
CIVIL ENGINEERS

VERTICAL SECTION ON LINE "C-C"

[Scale of original drawing]
1/8" = 1'-0"

ARTICLE VI
DETAIL DRAWINGS

Plates 46 to 61

Architectural details are those drawings made at a larger scale than the plans and elevations to describe accurately the various methods of construction and the mouldings and ornamentation of the building.

The scale of details varies according to the necessity of the case, $\frac{3}{4}'' = 1' - 0''$ being a good size for general detailing such as exterior elevations and wall sections while interior elevations are often made at a scale of $\frac{1}{2}'' = 1' - 0''$. Where absolute accuracy is required, such as for the fine mouldings of a mantel, full-size details are necessary.

The smaller scale details are usually included in the general drawings while full-size details are furnished only to the mechanic who is to get out that part of the work.

The details of any building consist principally of the following drawings.

First—Vertical wall sections describing all horizontal mouldings or belt courses, the sill, wall thickness, method of framing floor systems into walls, windows, cornice, and roof at the cornice. The detailed plan or jamb sections are sometimes shown on this drawing.

Second—Details of the exterior elevations which could not be described adequately by the small scale elevations.

Third—Detailed elevations and sections of the features of the interior such as doors, fireplaces, stairways, ornamental beams, cornices and other decorative features.

Fourth—Parts of the plan are detailed when necessary.

After the general drawings have been gotten out, the full-size details are completed, usually in the order in which the building is done. Thus the basement windows are almost always the first full-size details made for the better class of residence work, since these windows must be built and delivered before the basement wall can be completed. The interior trim, stair finish, etc., are full sized last for that is the last work to be put into the building.

There is a great variety of detail for each feature of a building, but it will be necessary for the student to study at this time only the standard methods of construction, and suggestions as to the drawing up of the principal details.

A careful study of the detail drawings of the Cochran residence, the Grace Methodist Church and the Cleveland office building, so that the student may understand the reason for each feature of the detail, will be of benefit to him in the production of similar drawings.

Stock sizes of material, particularly hardware, will often have a bearing on the design of a detail. Attention is called to this on some of the detail plates.

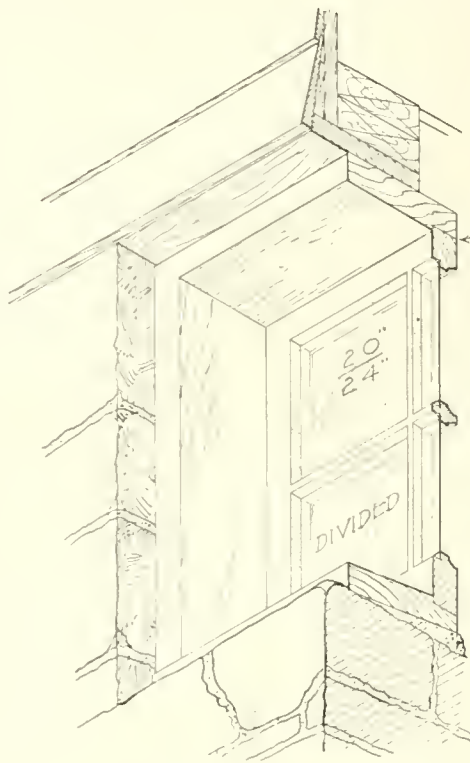

ISOMETRIC PICTURE
PART REMOVED TO SHOW CONSTRUCTION

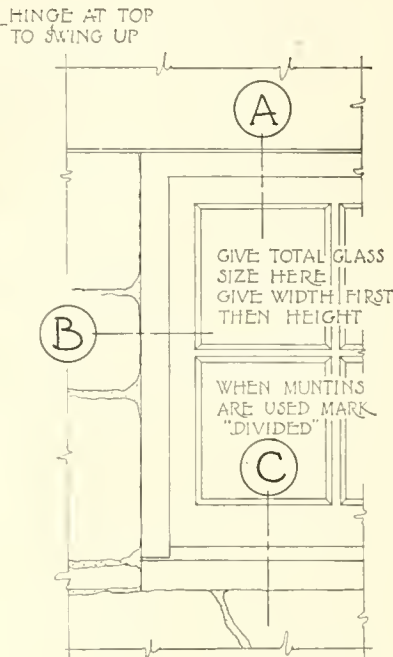

PART ELEVATION
OF OUTSIDE

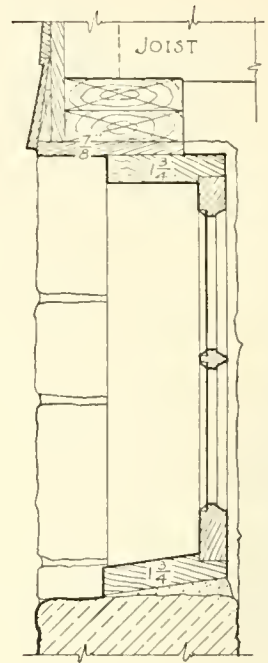

VERTICAL
SECTION

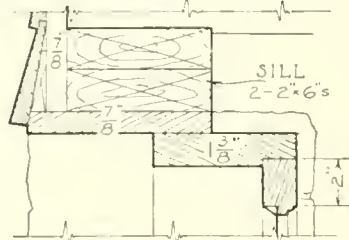

HEAD
SECTION "A"

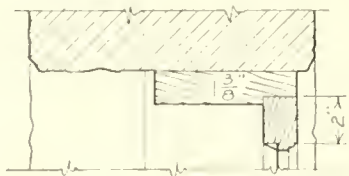

JAMB
SECTION "B"

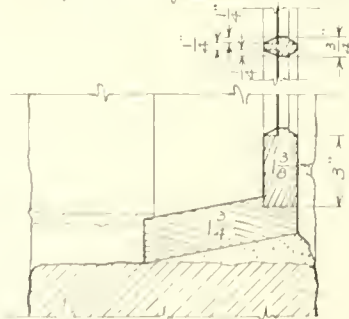

MUNTIN

CHEAP FRAME

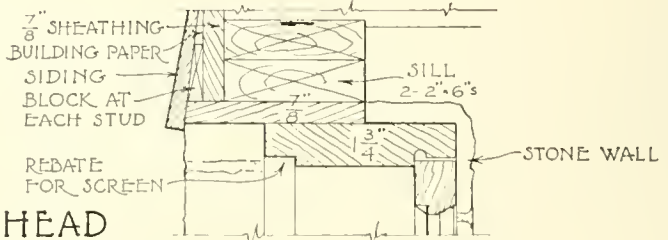

HEAD
SECTION "A"

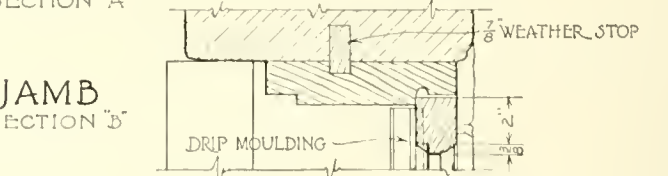

JAMB
SECTION "B"

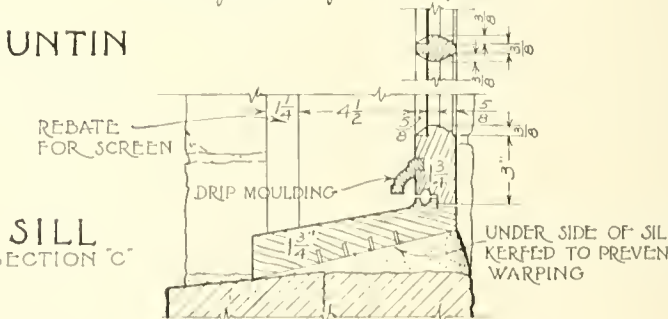

SILL
SECTION "C"

GOOD FRAME

SEE ALSO SHEET NO. 1
FOR CHEAP FRAME

DETAIL SECTIONS

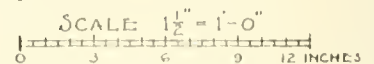

BASEMENT WINDOW IN FRAME WALL

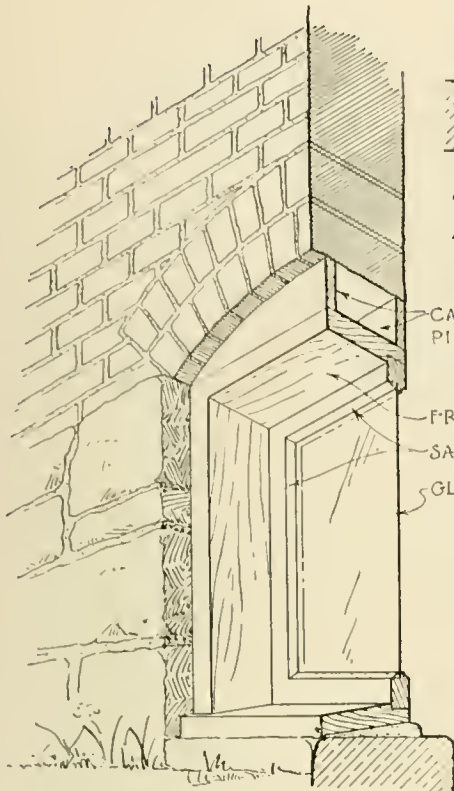

PERSPECTIVE PICTURE
PART REMOVED TO SHOW CONSTRUCTION

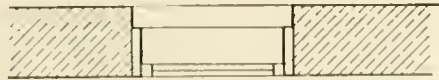

SYMBOL FOR THE WINDOW
AT A SCALE OF $\frac{1}{4}'' = 1'-0''$

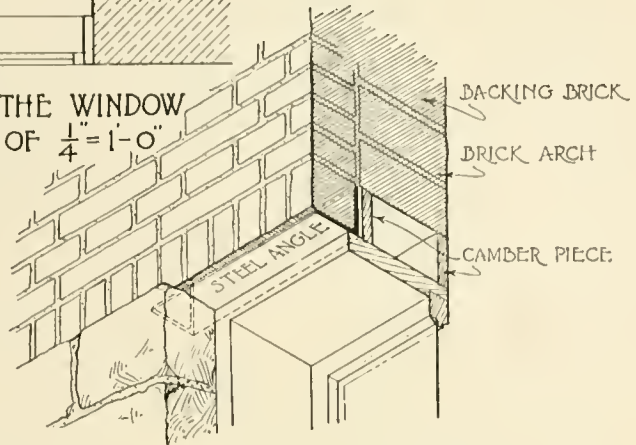

A WINDOW HEAD IN A BRICK WALL MAY BE BUILT AS SHOWN AT THE LEFT, WITH A BRICK ARCH EXTENDING ENTIRELY THROUGH THE WALL AND SUPPORTED AT FIRST BY THE CAMBER PIECES WHICH ARE BUILT ONTO THE FRAME. THIS ARCH OF COURSE SHOWS OUTSIDE THE WALL. WHEN THE DESIGN CALLS FOR A STRAIGHT LINE ACROSS THE WINDOW HEAD, THE BRICK ARCH MAY BE BUILT PART WAY THROUGH THE WALL SUPPORTING ONLY THE BACKING BRICK WHILE THE FOUR INCHES OF FACE BRICK IS CARRIED ON A STONE LINTEL OR A STEEL ANGLE AS SHOWN ABOVE.

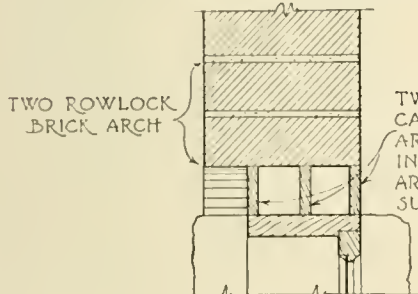

TWO ROWLOCK
BRICK ARCH

TWO OR MORE
CAMBER PIECES
ARE USED DEPEND-
ING ON WIDTH OF
ARCH TO BE
SUPPORTED

ARCH HEAD

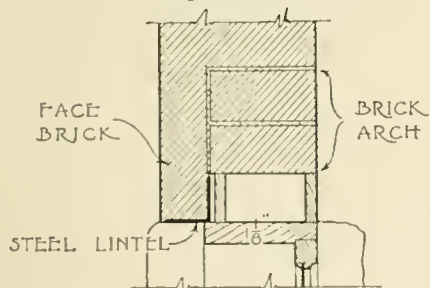

FACE
BRICK

BRICK
ARCH

STEEL LINTEL

ARCH AND
LINTEL HEAD

SCALE $\frac{3}{8}'' = 1'-0''$

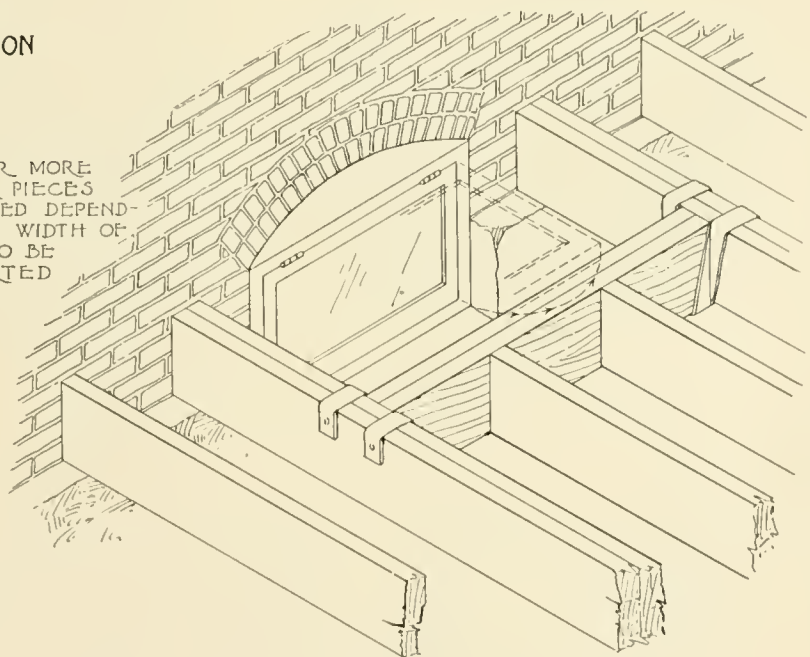

WHERE IT IS NECESSARY TO SET THE WINDOW HEAD HIGHER THAN THE BOTTOM OF THE FLOOR JOIST, THE FLOOR IS FRAMED AS SHOWN ABOVE TO ALLOW SPACE INTO WHICH THE SASH MAY SWING.

BASEMENT WINDOW IN BRICK WALL

SEE ALSO SHEETS NO. 8 AND NO. 9 RAE COCHRAN RESIDENCE [PLATES 28 AND 29]

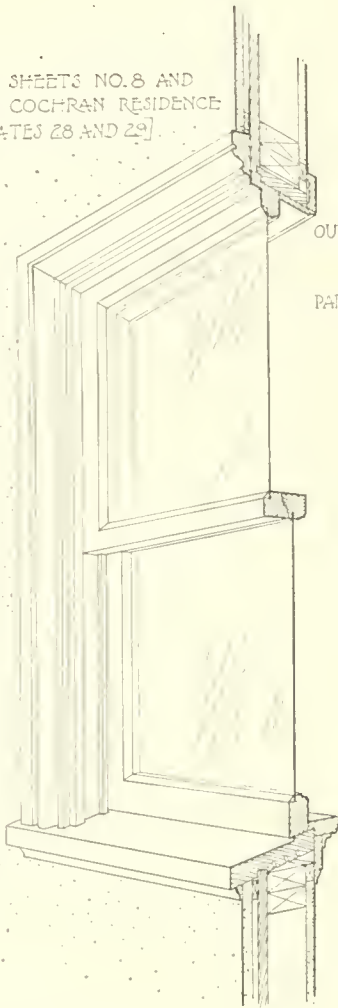

PERSPECTIVE VIEW WITH PART REMOVED TO SHOW CONSTRUCTION

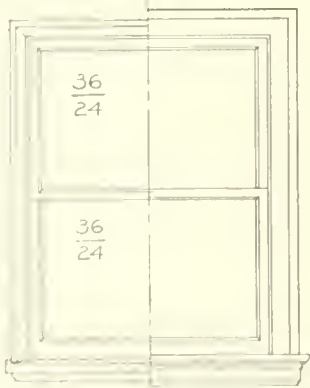

HALF OUTSIDE | HALF INSIDE ELEVATION

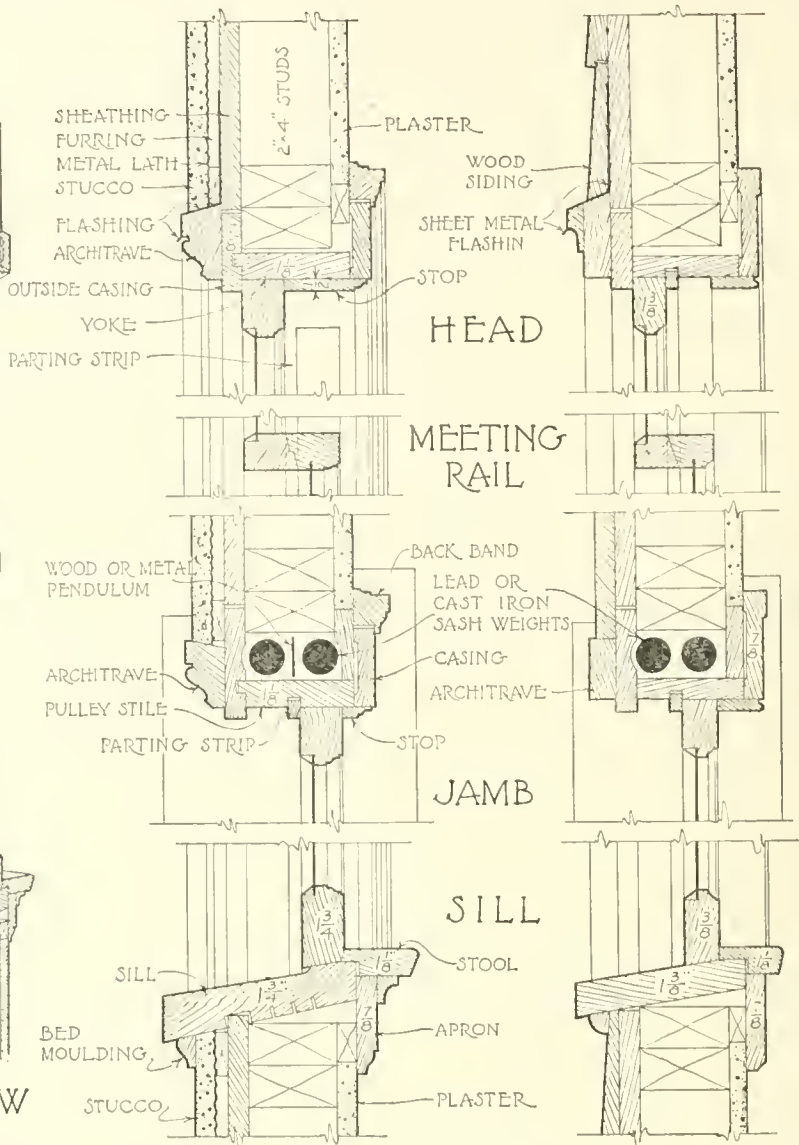

GOOD FRAME & SASH STUCCO WALL

CHEAP FRAME & SASH WOOD SIDING

DETAILED SECTIONS

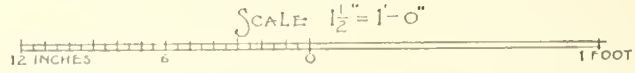

THE DETAILS OF THE DOUBLE HUNG WINDOW VARY SLIGHTLY IN DIFFERENT SECTIONS OF THE COUNTRY BUT ARE ESSENTIALLY AS HERE GIVEN. THE DESIGN OF MOULDINGS AND OF THE INSIDE AND OUTSIDE TRIM IS WORKED OUT TO SUIT THE DESIGN OF THE BUILDING. BELOW IS GIVEN THE METHOD OF INDICATING AT A SCALE OF $\frac{1}{4}'' = 1'-0''$ THE PLAN OF THE WINDOW IN A FRAME WALL.

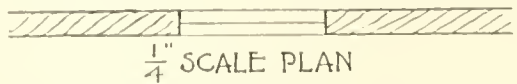

$\frac{1}{4}''$ SCALE PLAN

DOUBLE HUNG WINDOW IN FRAME WALL

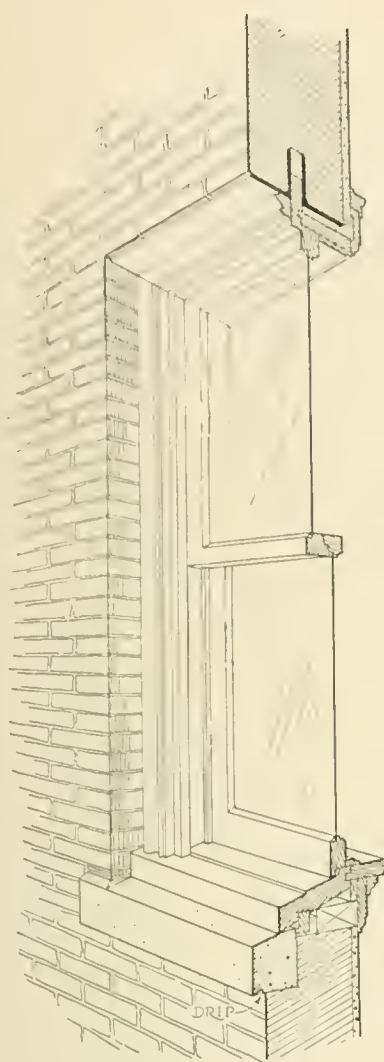

PERSPECTIVE VIEW
PART REMOVED
TO SHOW CONSTRUCTION

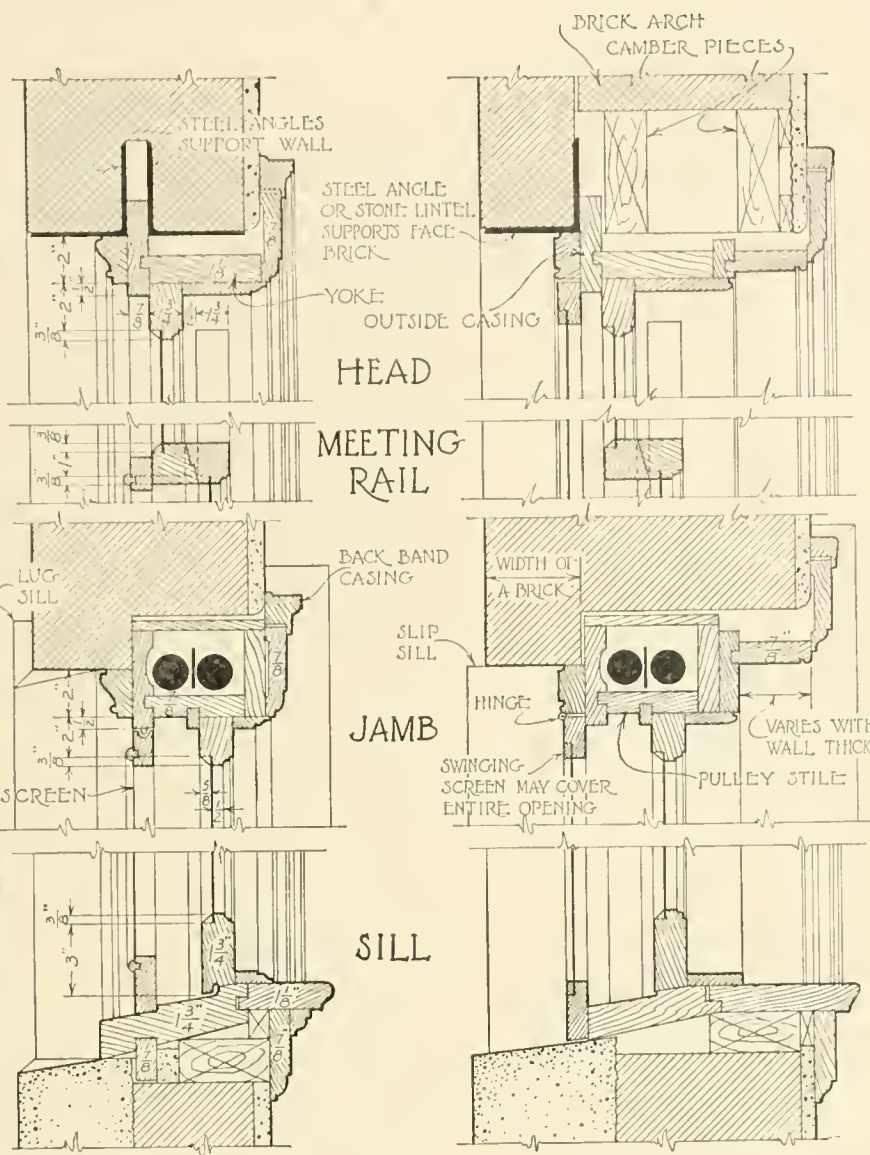

IN 9 INCH WALL

IN 13 OR 17 INCH WALL

DETAILED SECTIONS

SCALE: 1/2" = 1'-0"

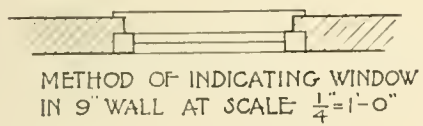
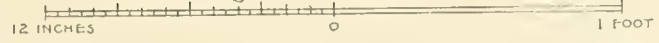

METHOD OF INDICATING WINDOW
IN 9" WALL AT SCALE 1/4" = 1'-0"

IN ALL BUT THE CHEAPEST WORK THE YOKE AND PULLEY STILES SHOULD BE FRAMED IN TO THE OUTSIDE CASING AS HERE SHOWN. THIS IS DONE TO PREVENT THEM FROM WARPING AND THEREBY CAUSING THE SASH TO BIND. THE INSIDE CASING BEING NAILED OR SCREWED TO THESE MEMBERS ASSISTS IN HOLDING THEM FIRMLY IN PLACE. THE PENDULUM, WHICH PREVENTS THE SASH WEIGHTS FROM INTERFERING, IS OFTEN OMITTED IN CHEAP FRAMES. THIS MEMBER IS SWUNG LOOSELY FROM THE TOP ONLY AND WHEN MADE OF THIN WOOD WILL SOMETIMES WARP. BECAUSE OF THIS A STIFF COPPER OR HEAVILY GALVANIZED IRON STRIP IS BETTER.

DOUBLE HUNG WINDOW IN BRICK WALL

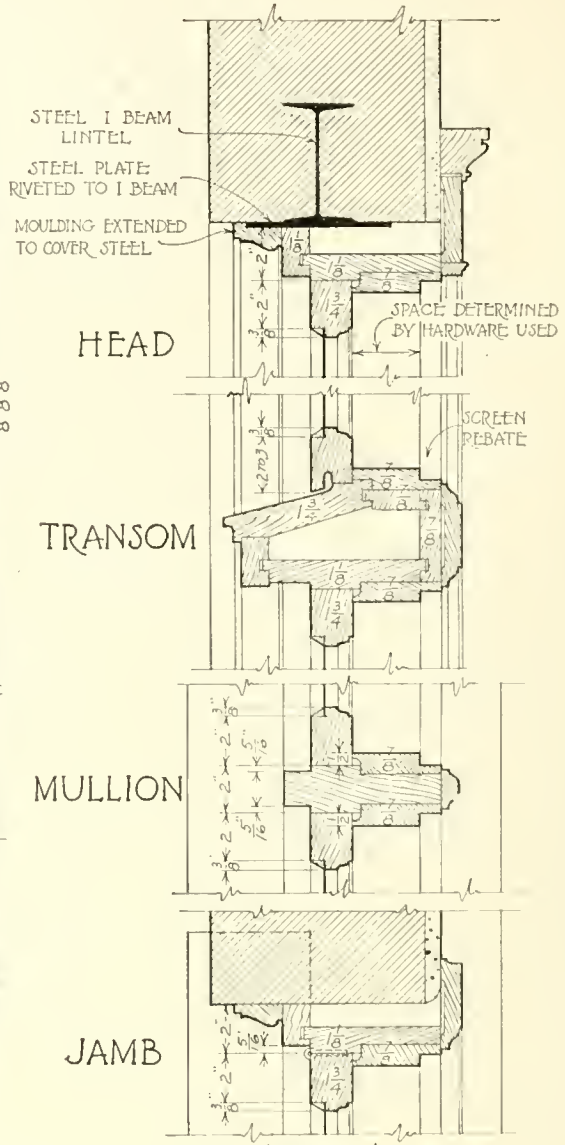
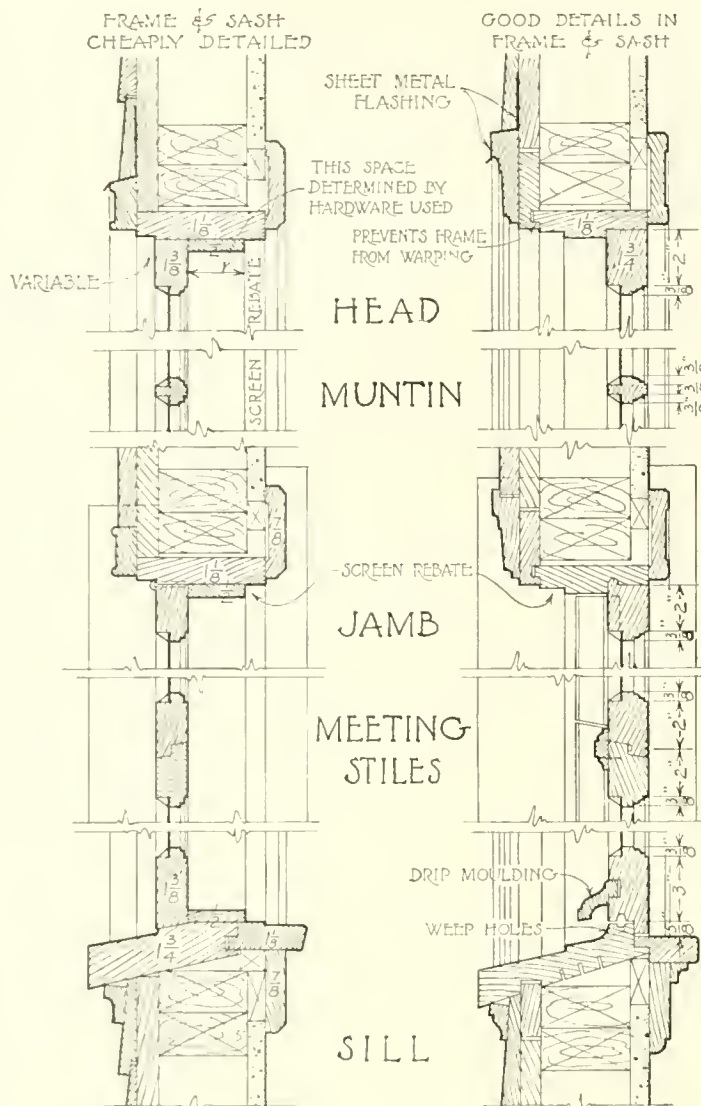

OUT SWINGING IN SWINGING
 DETAIL SECTIONS IN FRAME WALL

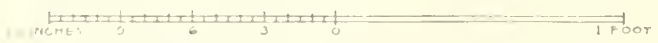

THE DETAILS OF CASEMENTS MUST BE CAREFULLY STUDIED TO OBTAIN SATISFACTORY RESULTS FOR IT IS VERY DIFFICULT TO MAKE THIS TYPE OF SASH WEATHER-TIGHT. THIS IS PARTICULARLY TRUE OF THE IN-SWINGING CASEMENTS. THE DETAILS GIVEN ARE TYPICAL AND MAY BE VARIED TO SUIT THE NEEDS OF THE CASE. WHEN THE OUTSIDE WOODWORK IS TO BE PAINTED AND THE INSIDE IS A FINISHED HARD WOOD, THE DETAIL SHOULD BE MADE WITH THIS IN MIND. THE SOFTER OUTSIDE WOOD SHOULD NOT SHOW ON THE INSIDE OF THE BUILDING AND THE MORE EXTENSIVE HARD WOOD SHOULD NOT BE USED FOR HEAVY PARTS OF THE FRAME. THIS IS ILLUSTRATED BY THE DETAIL AT THE RIGHT AND IS TRUE OF ALL FRAMES.

DETAIL FOR BRICK WALL
 OUT SWINGING

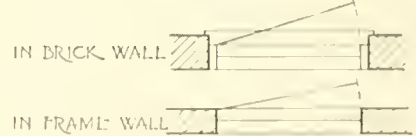

SYMBOLS FOR 1/4" PLANS

CASEMENT WINDOW DETAILS

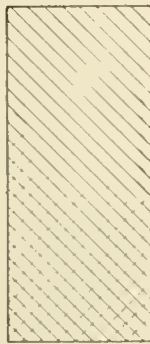

BATTENED



LEDGED

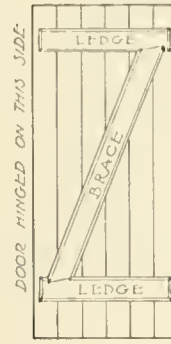

LEDGED & BRACED

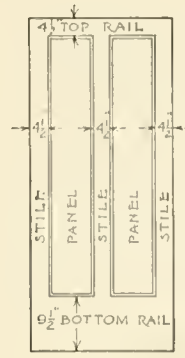

PANELED

TYPES OF INSIDE DOORS

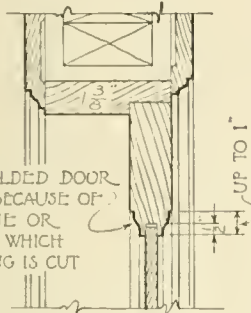

TYPICAL FOR HEAD & JAMB

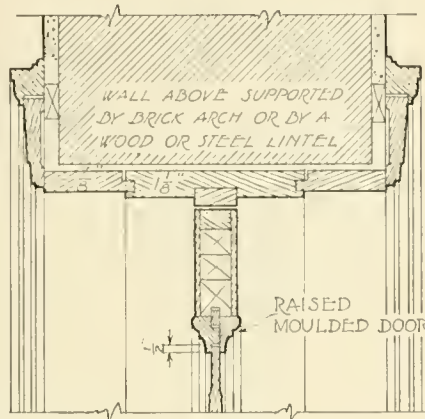

HEAD

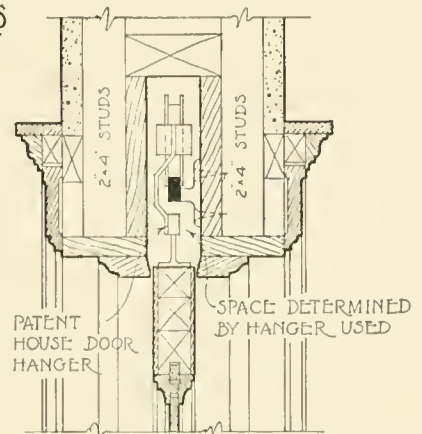

HEAD

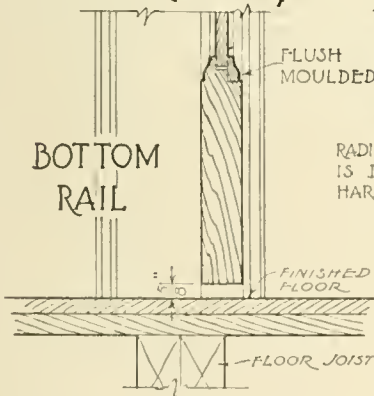

DOOR IN FRAME WALL

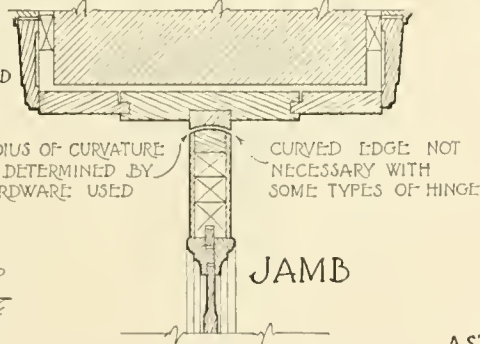

JAMB

DOUBLE SWINGING DOOR IN A 13 INCH BRICK WALL

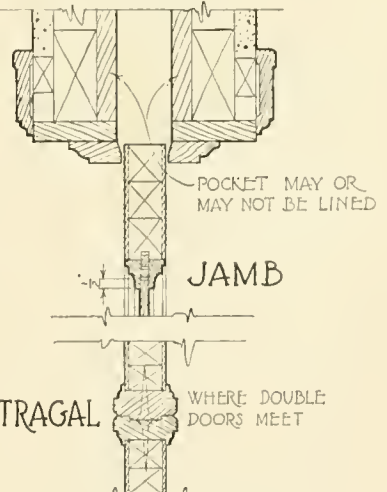

JAMB

SLIDING DOOR IN FRAME WALL

THE BATTENED DOOR IS THE TYPE USED FOR LARGE DOORS OF FACTORIES ETC. IT IS BUILT UP OF DIAGONAL MATCHED BOARDS AS INDICATED. THE LEDGED AND THE LEDGED AND BRACED DOOR ARE USED WHERE APPEARANCES ARE NOT IMPORTANT SUCH AS IN CELLARS ETC. THE PANELED DOOR IS BUILT UP OF HEAVY PARTS CALLED STILES AND RAILS INTO WHICH ARE FRAMED THE THIN PANELS. SUCH DOORS ARE SOLID AS AT THE LEFT OR ELSE THE STILES AND RAILS ARE BUILT OF STRIPS GLUED UP AND A THIN SHEET OF THE FINISHING WOOD OR VENEER IS GLUED OVER THE OUTSIDE AS ABOVE.

SCALE OF ALL SECTIONS
1 1/2" = 1'-0"

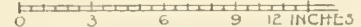

DETAILS OF INSIDE DOORS

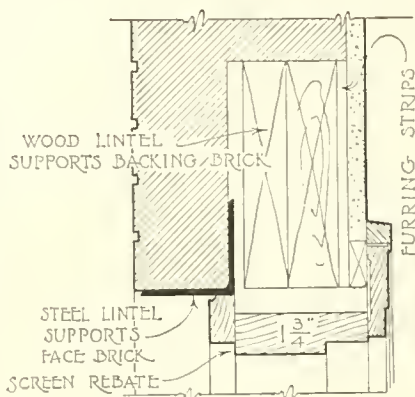
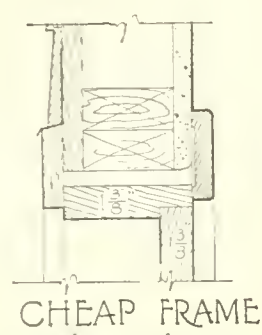

HEAD

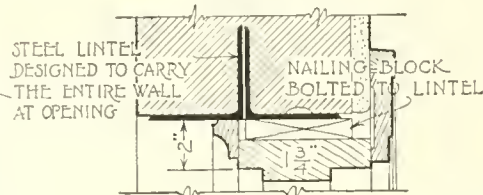
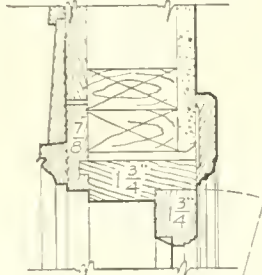

HEAD

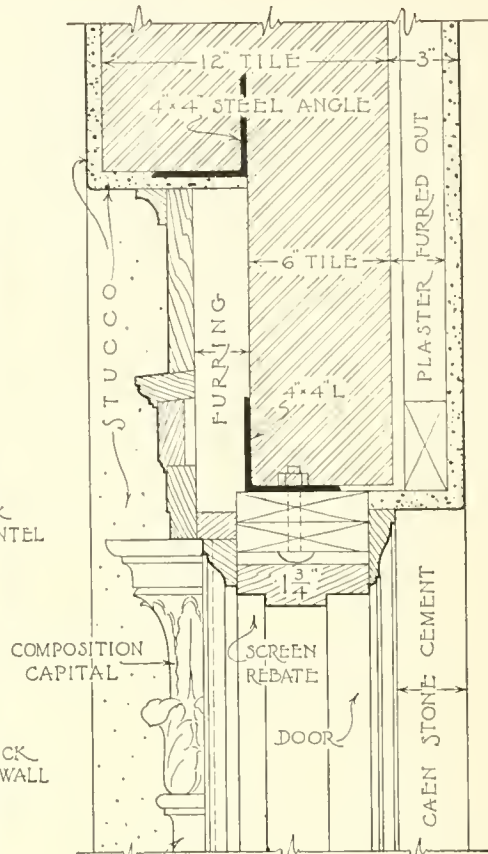

HEAD

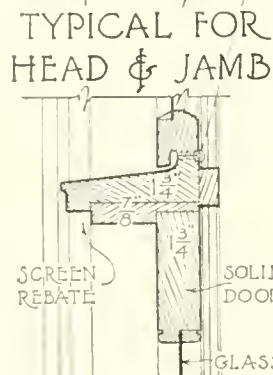

TRANSOM BAR

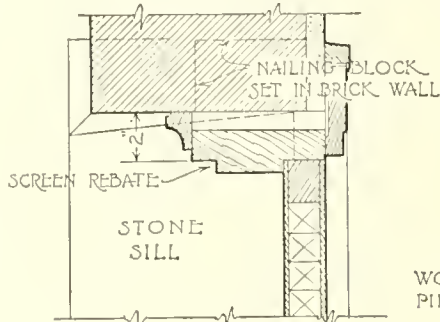

JAMB

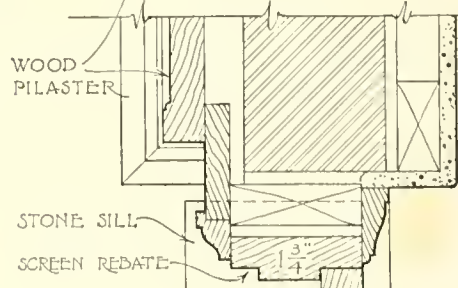

JAMB

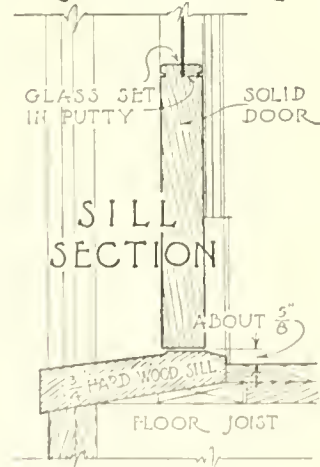

SILL SECTION

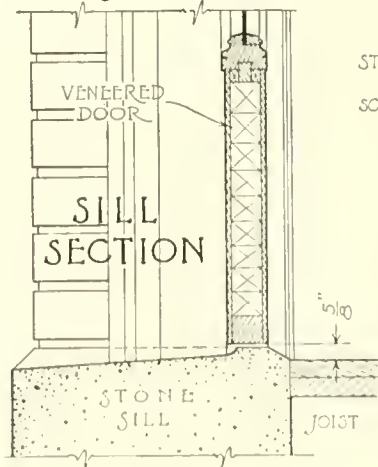

SILL SECTION

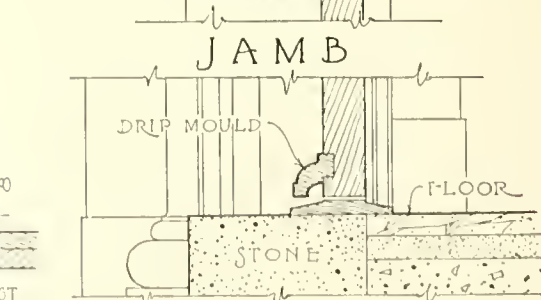

SILL SECTION

DETAIL IN FRAME WALL WITH TRANSOM

IN BRICK WALL

DETAIL BY HOWELL & THOMAS ARCHITECTS CLEVELAND OHIO

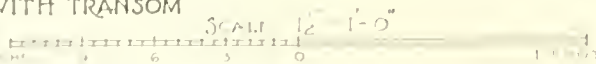

DETAILS OF OUTSIDE DOORS

[THIS NOTE IS GIVEN ON THE ORIGINAL TO SAFEGUARD AGAINST ANY POSSIBLE DISCREPANCY BETWEEN THE CURVE OF THE STONE ARCH AND THAT OF THE WOODEN FRAME. SUCH AN ERROR IS VERY LIKELY TO CREEP IN WHEREVER THE WORK OF TWO CONTRACTORS MUST FIT TOGETHER PERFECTLY AND IT IS WELL TO CALL ATTENTION TO THIS FACT BY A NOTE ON THE DETAIL.]

NOTE--VERIFY RADII BY CHECKING SAME WITH STONE ARCH ON THE JOB.

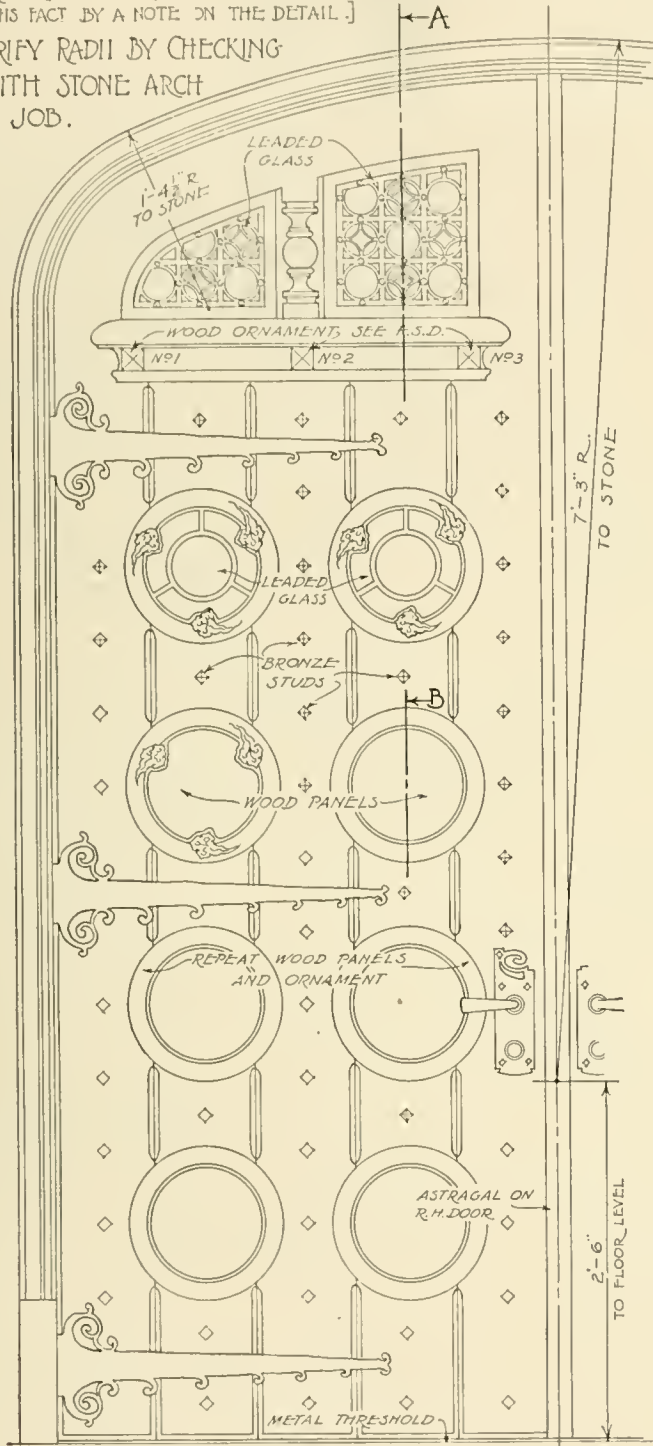

ELEVATION OF ONE DOOR

SCALE $\frac{3}{4}'' = 1'-0''$

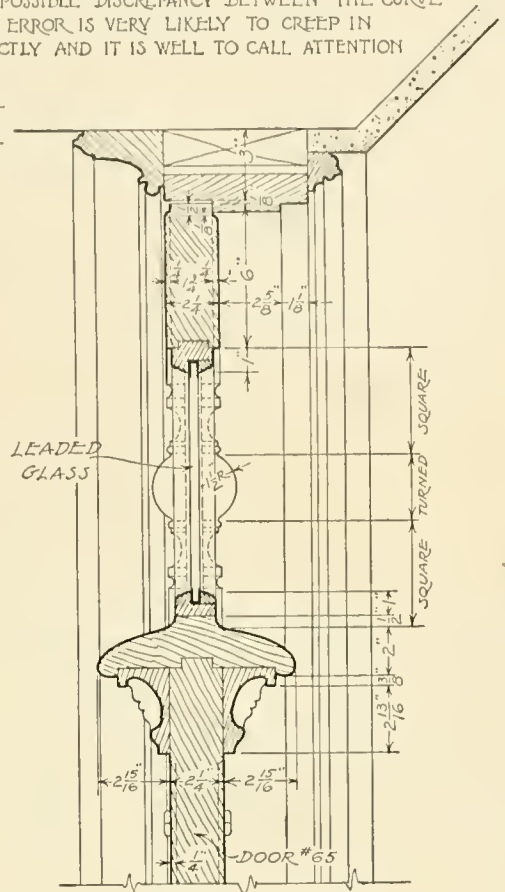
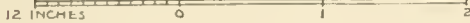

SECTION "A"

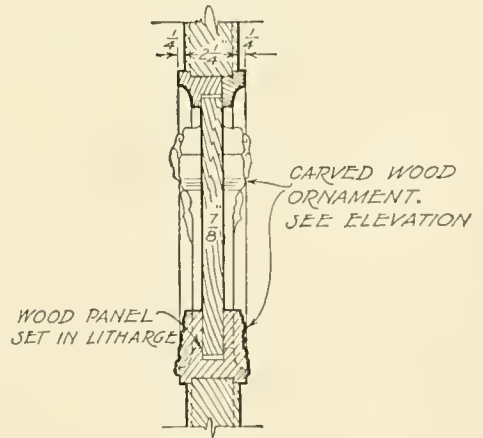

SECTION "B"

SCALE OF SECTIONS $1\frac{1}{2}'' = 1'-0''$

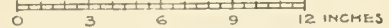

[ON THE ARCHITECTS DRAWING THE DOOR ELEVATION IS MADE AT A SCALE OF 3"=1'-0". ALL SECTIONS & ELEVATIONS OF PARTS ARE DRAWN FULL SIZE. ONLY THE PRINCIPAL SECT'S. ARE HERE GIVEN.]

[Redrawn from the plans of]
SCHENCK & WILLIAMS - ARCHTS
DAYTON OHIO

DETAIL OF DOOR NO 65

GRACE METHODIST CHURCH
DAYTON OHIO

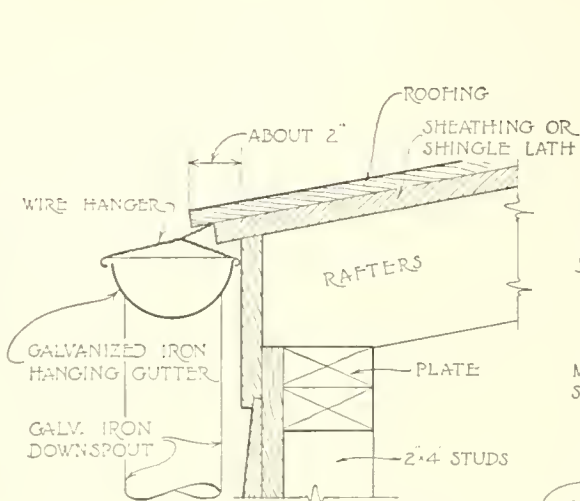

SIMPLEST FORM

USED ON SHEDS, FACTORY BUILDINGS ETC. AND WHERE APPEARANCES ARE NOT A CONSIDERATION.

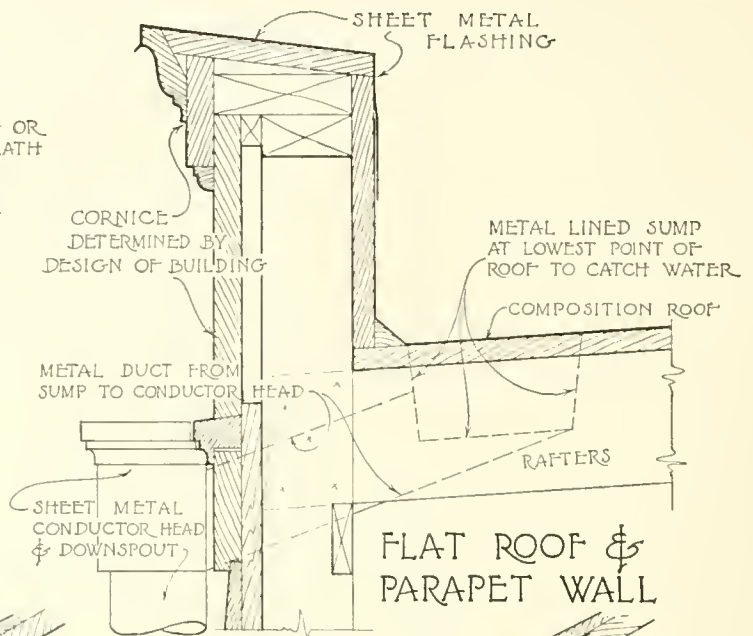

FLAT ROOF & PARAPET WALL

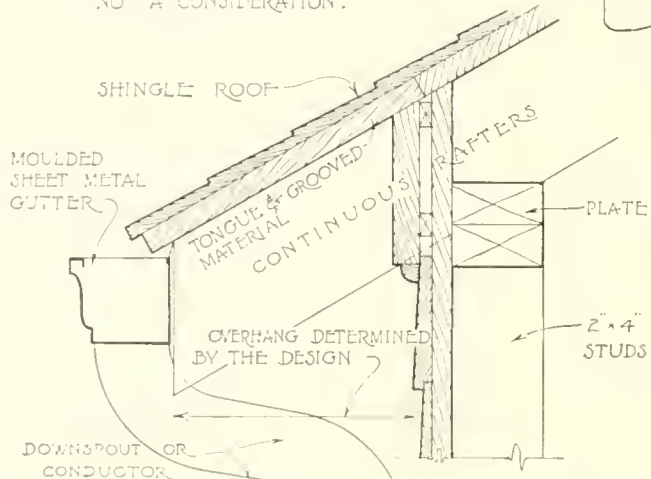

**PROJECTING CORNICE
OPEN RAFTERS**

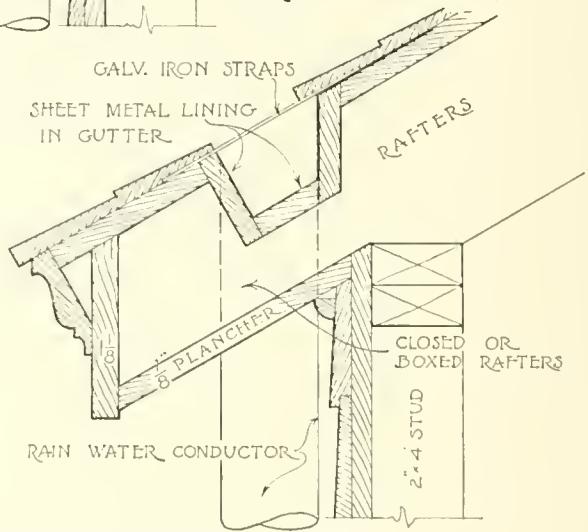

CONCEALED GUTTER

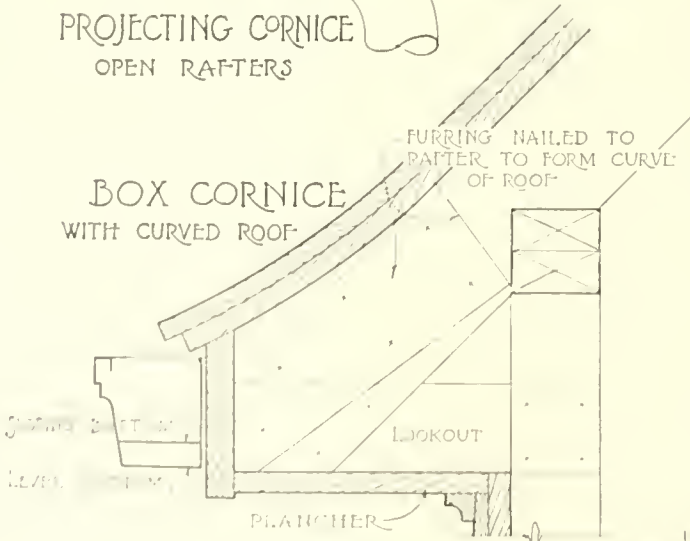

**BOX CORNICE
WITH CURVED ROOF**

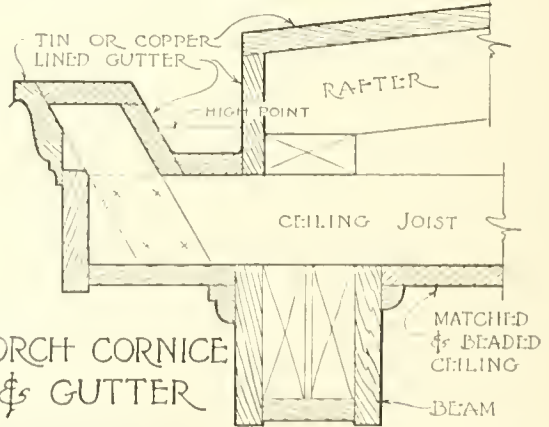

**PORCH CORNICE
& GUTTER**

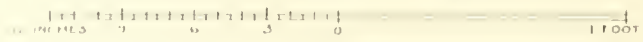

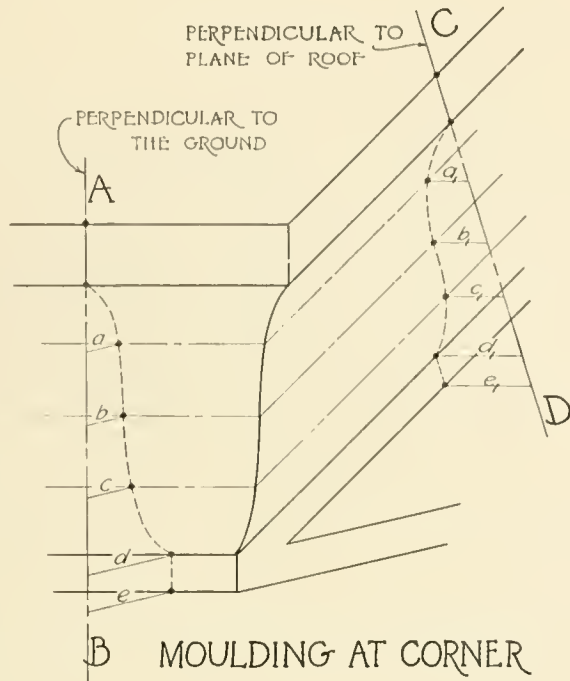
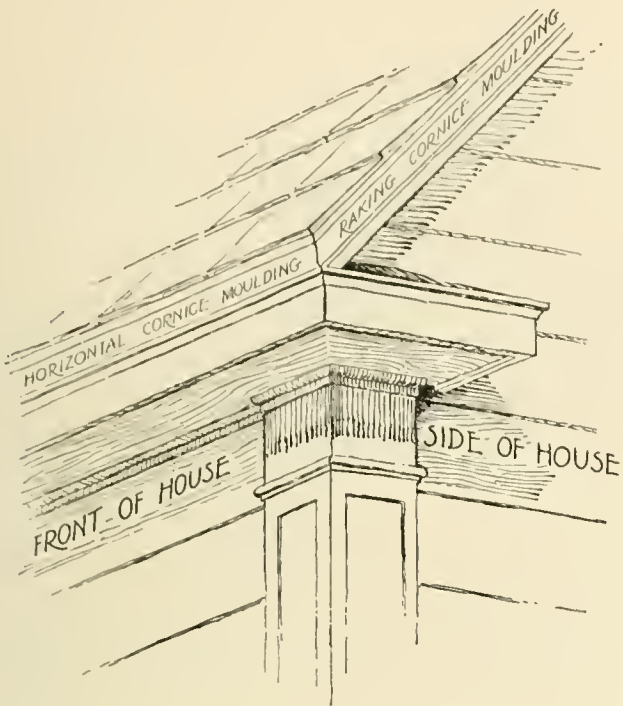

IN THE PICTURE ABOVE IS SHOWN A CONDITION IN WHICH A HORIZONTAL MOULDING INTERSECTS A RAKING OR SLOPING MOULDING AT THE CORNER OF A BUILDING. IF BOTH MOULDINGS ARE OF THE SAME PROFILE THEY WILL NOT FIT TOGETHER AT THE CORNER. THE DRAFTSMAN, AFTER HAVING ESTABLISHED THE PROFILE OF THE HORIZONTAL MOULDING, MUST DETERMINE THE PROPER PROFILE FOR THE RAKING MOULDING SO THAT THE TWO WILL MITER TOGETHER ACCURATELY AT THIS POINT. TO ACCOMPLISH THIS HE PROCEEDS AS SHOWN BELOW.

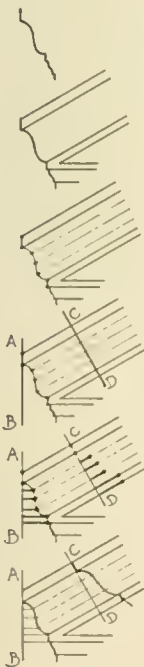

- ① ESTABLISH THE PROFILE OF HORIZONTAL MOULDING.
- ② DRAW SIDE VIEW OF RAKING MOULDING NOTICING THAT END OF MOULDING HAS SAME PROFILE AS HORIZONTAL MOULD.
- ③ LOCATE SEVERAL POINTS ON THE PROFILE AND DRAW THE DOT AND DASH LINES AS SHOWN.
- ④ DRAW LINE A-B PERPENDICULAR TO THE GROUND AND LINE C-D PERPENDICULAR TO THE SLOPING ROOF.
- ⑤ FROM C-D LAY OFF "a₁" EQUAL TO "a" THEN "b₁" EQUAL TO "b" ETC. LOCATING ENOUGH POINTS FOR ACCURATE WORK.
- ⑥ CONNECTING THESE POINTS WILL GIVE THE PROFILE OF THE RAKING MOULDING.

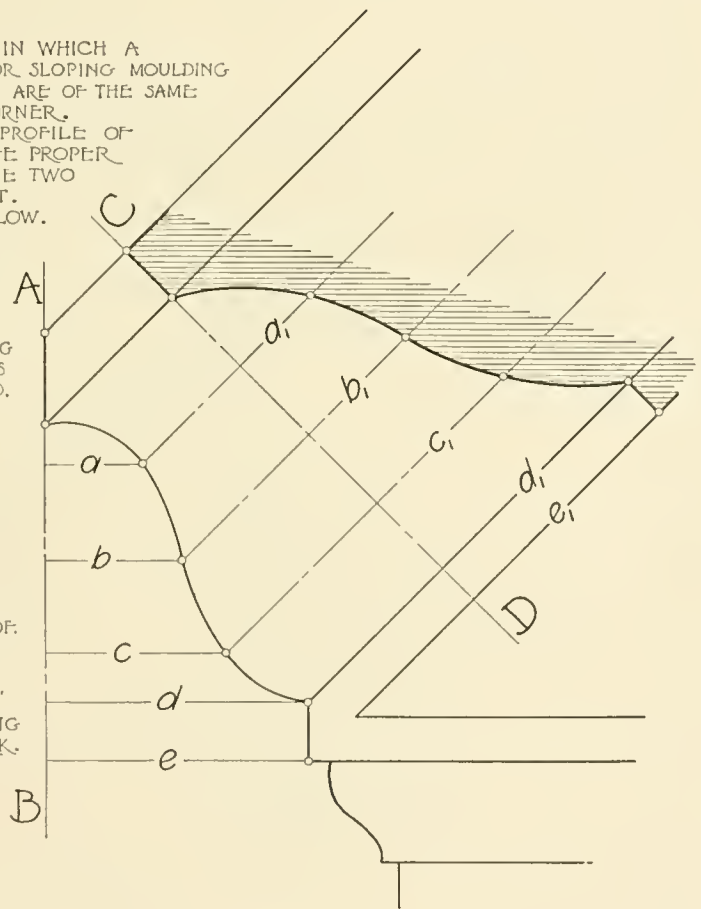

CORNICE MOULDING FOR GABLE END

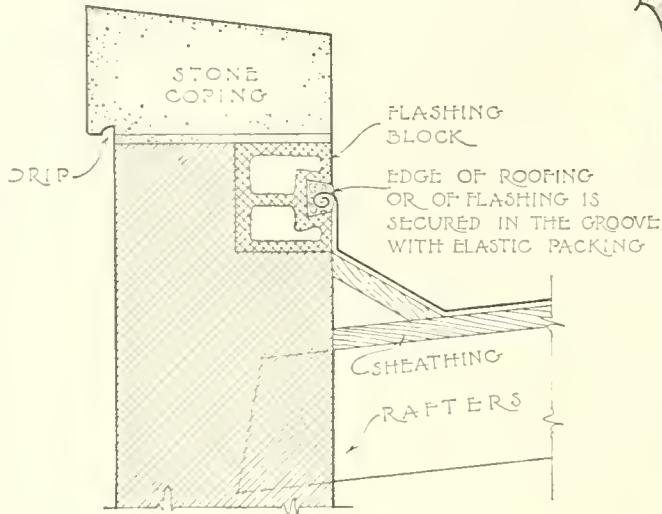

FLAT ROOF
& PARAPET WALL

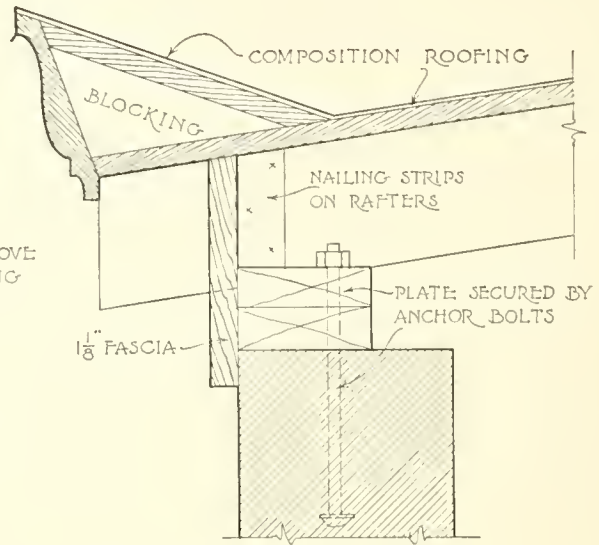

SIMPLE CORNICE &
CONCEALED GUTTER ON FLAT ROOF

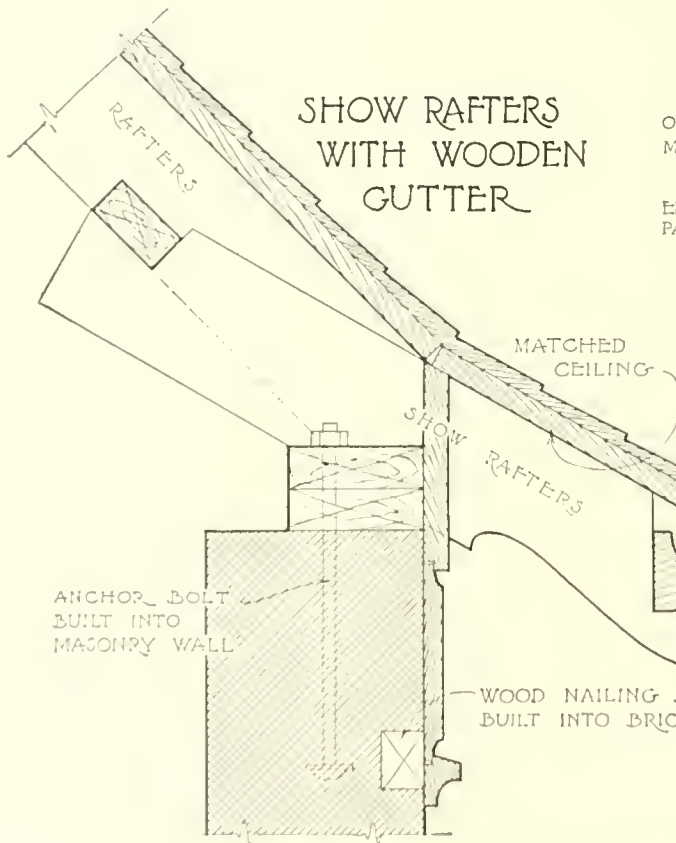

SHOW RAFTERS
WITH WOODEN
GUTTER

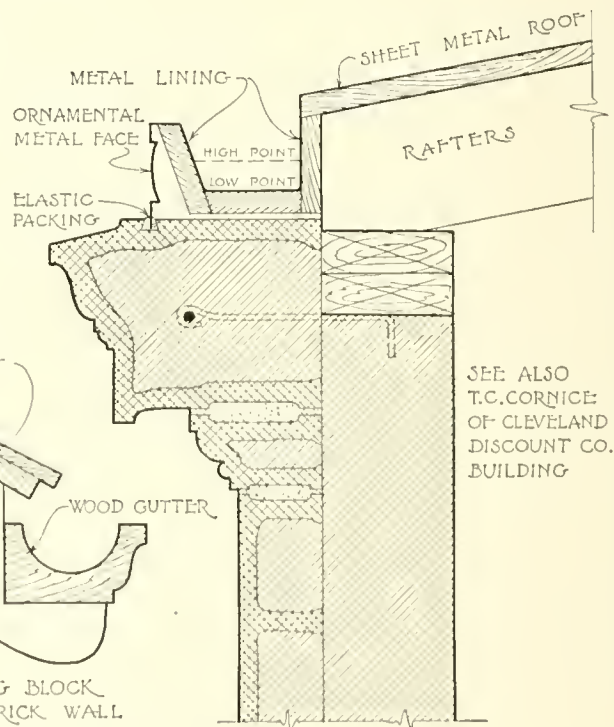

TERRA COTTA CORNICE
WITH METAL LINED WOOD GUTTER

SEE ALSO
T.C. CORNICE
OF CLEVELAND
DISCOUNT CO.
BUILDING

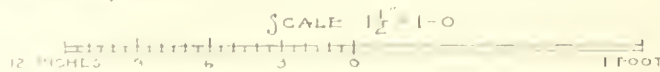

STAIRWAYS

There are two general types of stairways, the closed stair where the steps are built in between walls, and the open stair which may have a balustrade on one side and a wall on the other or balustrades on both sides. See **Plate 58**.

Following are a few general rules and reminders which should be observed in laying out a stair so as to obtain the most of comfort and safety in their use, and ease in their erection.

That part of the stair on which we step is called the *tread* and the vertical part of the step is called the *riser*. The total distance from floor to floor is called the *rise* and is equal to the sum of the heights of all the risers. The horizontal distance from the face of the bottom riser to the face of the top riser is called the *run* and is equal to the sum of all the treads. These are all noted on **Plate 59**.

So that one may take steps of normal length in walking up a stairway, the size of riser and tread must be considered carefully. The height of one riser plus the width of one tread should not be less than 17 inches and not more than 18 inches. Another good rule is to make two risers plus one tread equal 24 inches. A good average for residence work is to make the riser 7 inches and the tread 10 inches. Treads should never be less than 9 inches from face to face of risers of wood stairs or 10 inches for stone steps. The overhanging part of the tread is called the *nosing* and is not included when width of tread is figured nor is it shown on the scale drawings. See **Plates 58** and **59**. All risers must be the same height and all treads must be the same width on a stairway. Unequal treads or risers will form a stumbling place on the stair.

The steps of a curving stair are called *winders* and when they occur in the same stair with straight steps, the treads of the winders should be the same width on the *walking line* as those of the straight steps.

All stairways should be well lighted, both naturally and artificially.

A front stair should not be narrower than 3' - 0". The top of a handrail should be about 2' - 6" above the tread measuring vertically in the plane of the riser. This height may be increased to 2' - 8" or more where the rail runs level as on landings.

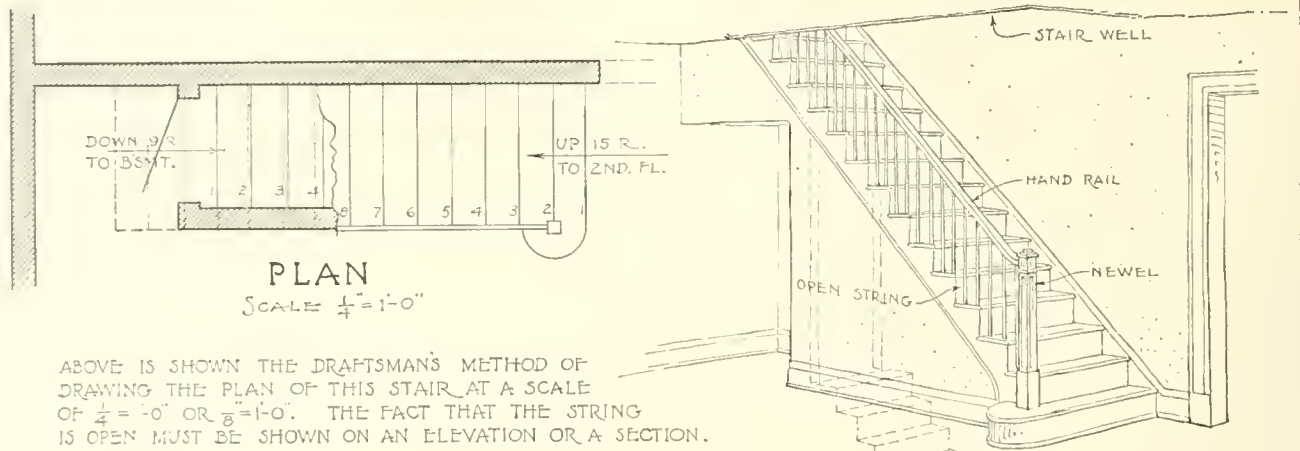

PLAN
SCALE = $\frac{1}{4}'' = 1'-0''$

ABOVE IS SHOWN THE DRAFTSMAN'S METHOD OF DRAWING THE PLAN OF THIS STAIR AT A SCALE OF $\frac{1}{4}'' = 1'-0''$ OR $\frac{3}{8}'' = 1'-0''$. THE FACT THAT THE STRING IS OPEN MUST BE SHOWN ON AN ELEVATION OR A SECTION.

SINGLE FLIGHT TO SECOND FLOOR, OPEN STAIR WITH OPEN STRING, CLOSED BASEMENT STAIR DIRECTLY UNDERNEATH

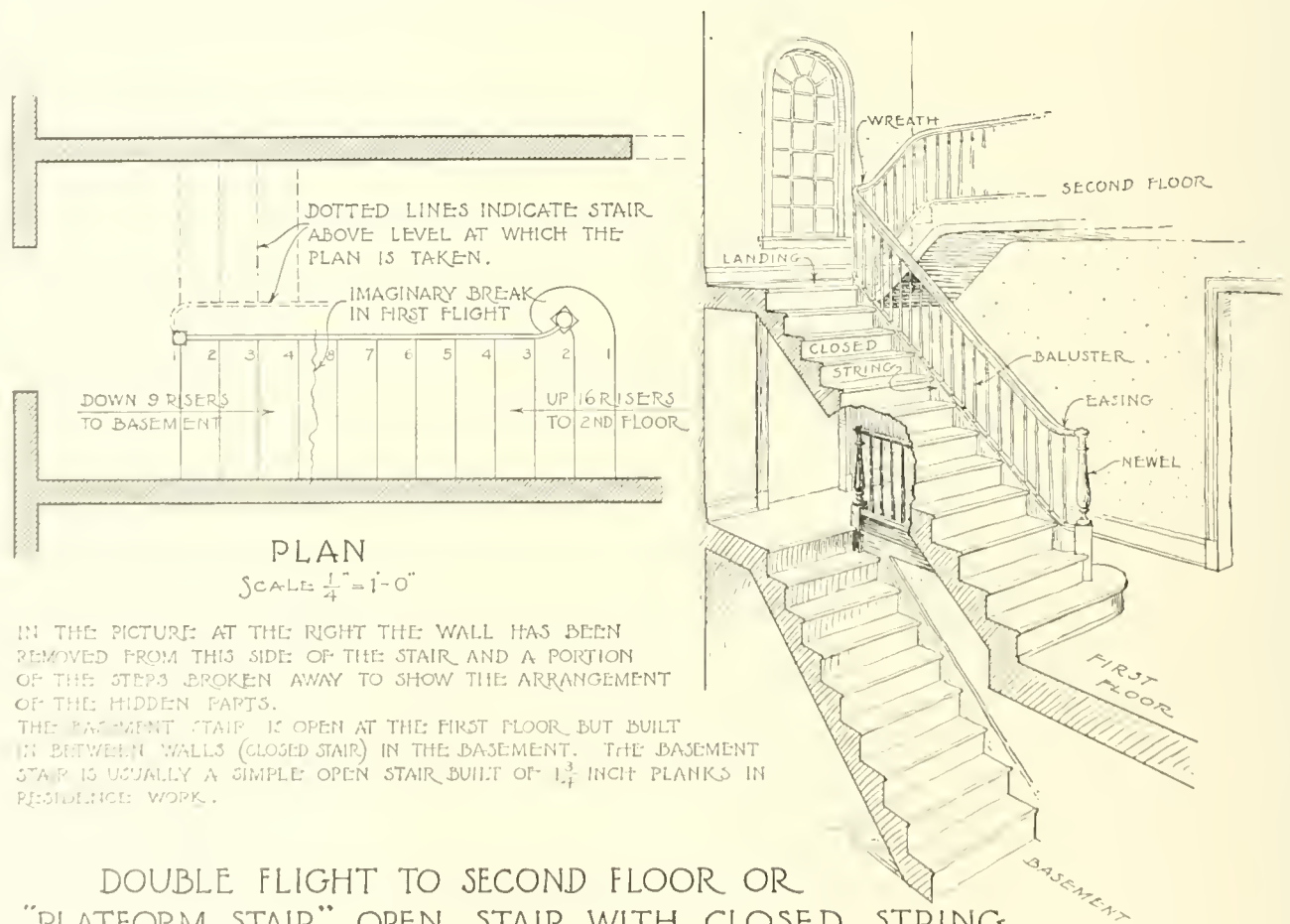

PLAN
SCALE = $\frac{1}{4}'' = 1'-0''$

IN THE PICTURE AT THE RIGHT THE WALL HAS BEEN REMOVED FROM THIS SIDE OF THE STAIR AND A PORTION OF THE STEPS BROKEN AWAY TO SHOW THE ARRANGEMENT OF THE HIDDEN PARTS. THE BASEMENT STAIR IS OPEN AT THE FIRST FLOOR BUT BUILT IN BETWEEN WALLS (CLOSED STAIR) IN THE BASEMENT. THE BASEMENT STAIR IS USUALLY A SIMPLE OPEN STAIR BUILT OF $1\frac{3}{4}$ INCH PLANKS IN RESIDENCE WORK.

DOUBLE FLIGHT TO SECOND FLOOR OR "PLATFORM STAIR", OPEN STAIR WITH CLOSED STRING

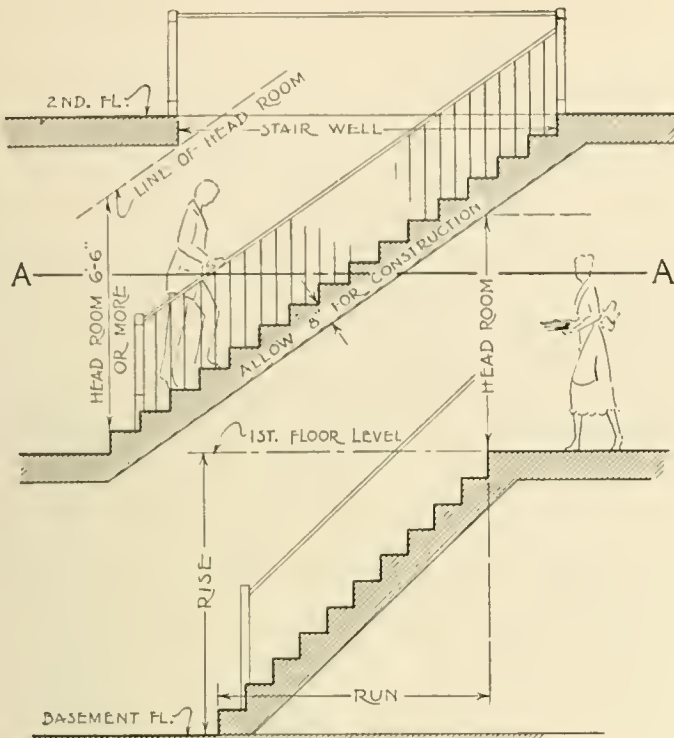

SECTION THRU STAIRWAY

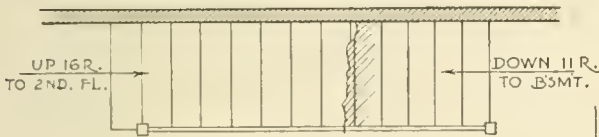

PLAN AT LEVEL "A-A"

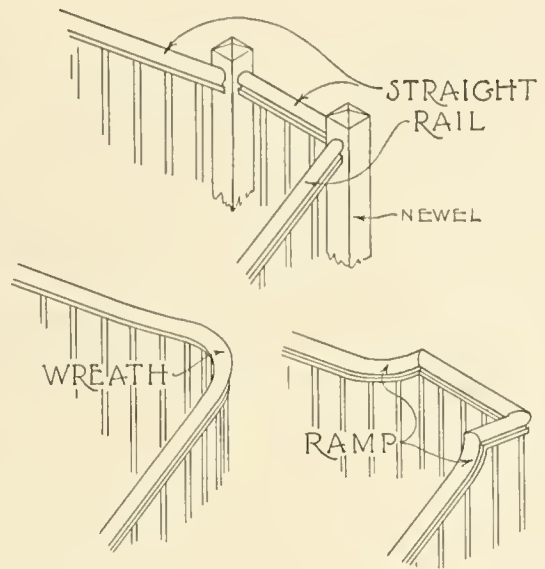

TYPES OF HANDRAIL TURNS

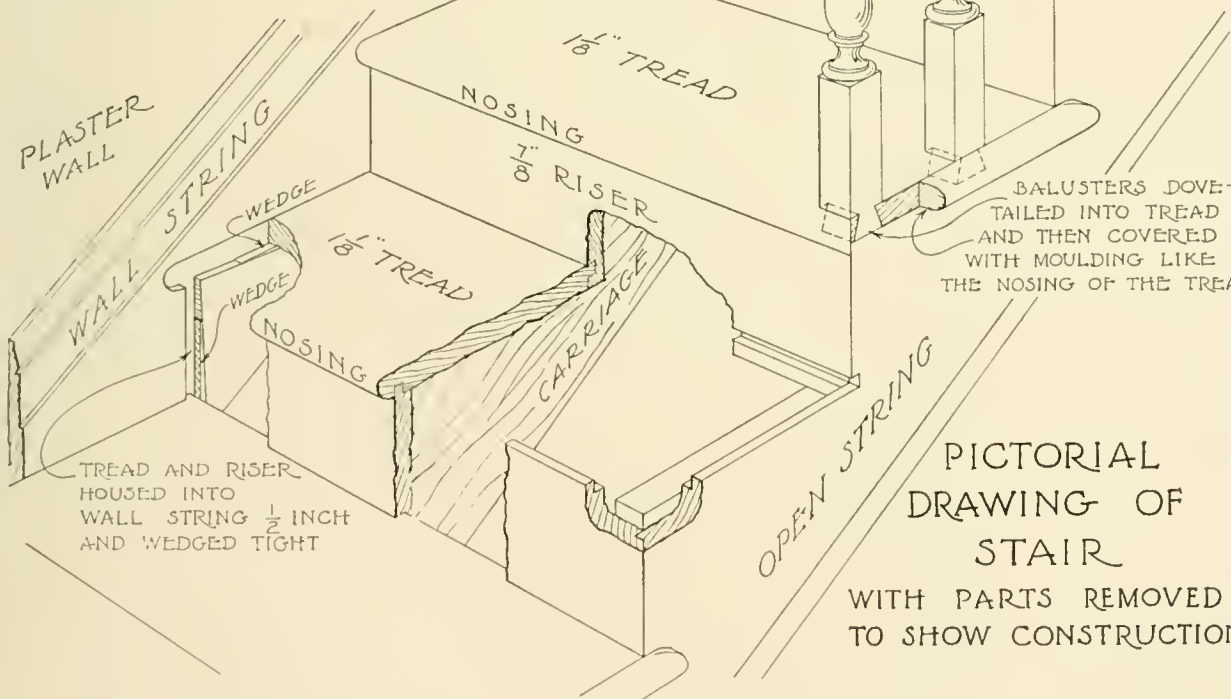

PICTORIAL DRAWING OF STAIR

WITH PARTS REMOVED TO SHOW CONSTRUCTION

STAIRWAY DETAILS

[IN A DRAWING OF THIS KIND, WHICH IS OF NECESSITY RATHER LARGE, THE PLAN IS OFTEN DRAWN DIRECTLY ON TOP OF THE ELEVATION AS HERE SHOWN. IN SO DOING CARE MUST BE USED THAT THE DRAWING MAY NOT BECOME CONFUSING. NOTICE THAT ONLY ONE BALUSTER OR SPINDLE IS DRAWN IN ELEVATION WHILE ALL OF THEM ARE LOCATED ON THE PLAN. THIS DRAWING TOGETHER WITH A SCALE DETAIL OF THE ENTIRE STAIRWAY DESCRIBES FULLY THIS FEATURE OF THE BUILDING.]

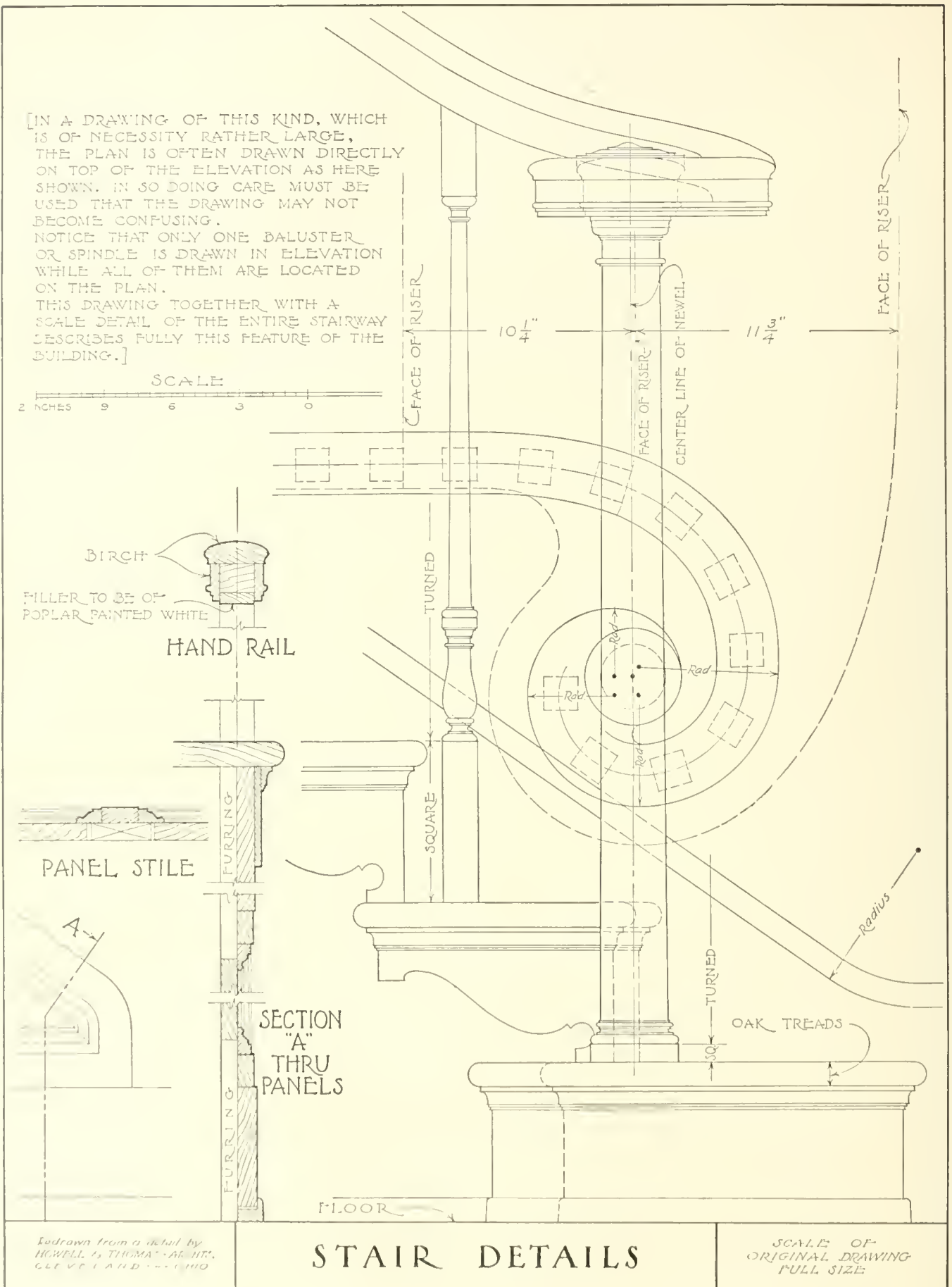
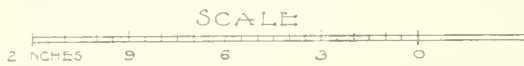

Redrawn from a detail by
HOWELL & THOMAS - ARCHTS.
CLEVELAND - OHIO

STAIR DETAILS

SCALE OF
ORIGINAL DRAWING
FULL SIZE

ARCHITECTURAL DRAWING

Handrails are either continuous with a curved portion or wreath where they change direction or else they are straight and have newel posts where they change direction as shown in **Plate 59**, Types of Handrail Turns. The last mentioned rail is usually the cheaper one to build. Starting newels should extend down through the floor and be bolted to the floor joist or else fastened to a timber which has been so bolted. Landing newels should carry down similarly through the landing so as to afford a secure fastening. The center line of the handrail should be on the center line of the newels and may be assumed to come directly over the face of the plaster wall or the wood panels below. See **Plate 60**. Where possible, let risers intersect newels on the center line of the newel. See **Plate 58**.

Special attention should be given to the *head room* on a stairway and this should never be less than $6' - 6''$ as shown by the stairway section on **Plate 59**, and should be $7' - 0''$ to $8' - 0''$ if space will permit.

The construction to carry the stair must be kept in mind and sufficient space allowed for strings and carriages.

It is always well and often necessary to draw a section through the stairway similar to that on **Plate 59**. This section should show the newels, balusters, rails, etc. Draw it in such a way as best to show the stairway. The one given on the plate is merely diagrammatic.

On the scale drawings should be shown in plan and elevation the location of the risers, the handrails and newels and a few general dimensions such as the rise, the run, the width to center line of handrail and the height of the handrail. Sometimes the risers are numbered beginning with the bottom riser. This is for convenience in reading the drawing. See **Plates 22** and **37**.

Sometimes only the mouldings of a stairway are detailed full size, but for good work, full-size details are made of the newels, rails, balusters and all mouldings, and sometimes of the entire start of the stair, such as that given on **Plate 60**.

The diagonal use of the scale as described by Fig. 30 on **Plate 4** affords a handy way of laying off any number of steps quickly and accurately.

TABLE OF DIMENSIONS

WIDTH OF OPENING	HEIGHT OF OPENING	DEPTH OF FIREPLACE	DREAST	WIDTH OF BACK	THROAT	FLUE	E	F	G
3-0	2-4	1-4	8	1-6	4	8x12	13	10	13
3-6	2-4	1-4	8	1-6	4	12x12	13	10	13
4-0	2-6	1-4	8	1-8	4	12x12	13	10	15
4-6	2-8	1-6	8	2-0	4	12x12	14	10	16
5-0	3-0	1-8	12	2-0	4	12x18	15	12	21

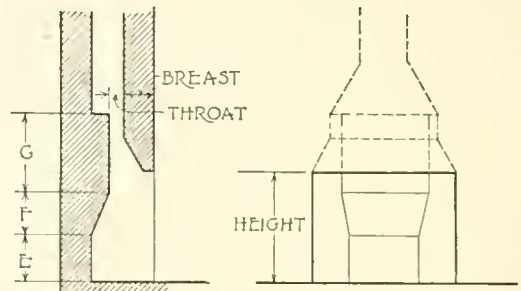

SECTION

ELEVATION

THE ABOVE DIAGRAM AND TABLE OF DIMENSIONS MAY BE USED AS A GUIDE IN LAYING OUT A SUCCESSFUL FIREPLACE OF THE WIDTH NOTED. THE DIMENSIONS NEED NOT BE FOLLOWED EXACTLY BUT THE PROPORTIONS SHOULD BE PRESERVED AS NEARLY AS THE MATERIAL USED WILL PERMIT. THE PICTURE GIVES A COMPREHENSIVE IDEA OF A FIREPLACE AND MANTEL WHILE THE ELEVATION, SECTION AND PLAN SHOW THE ARCHITECT'S DRAWINGS OF THIS DETAIL.

- A FLUE
- B SMOKE CHAMBER
- C PATENT DAMPER
- D THROAT
- E BREAST

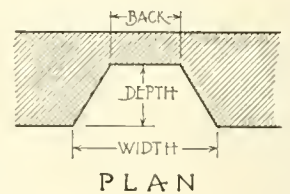

PLAN

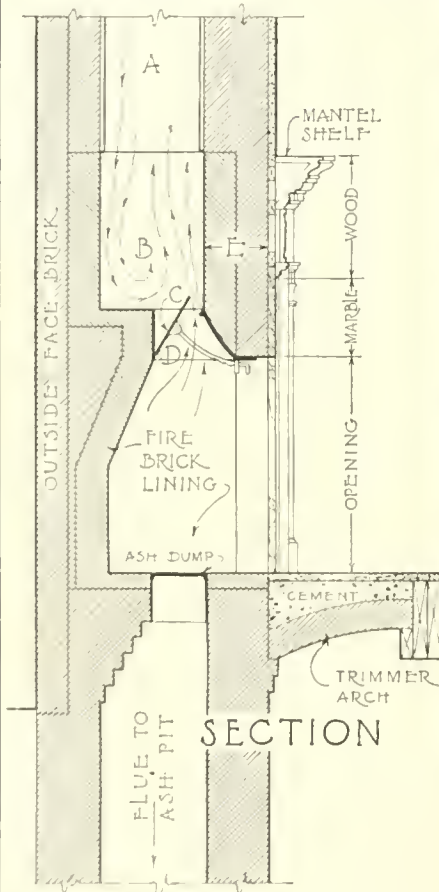

SECTION

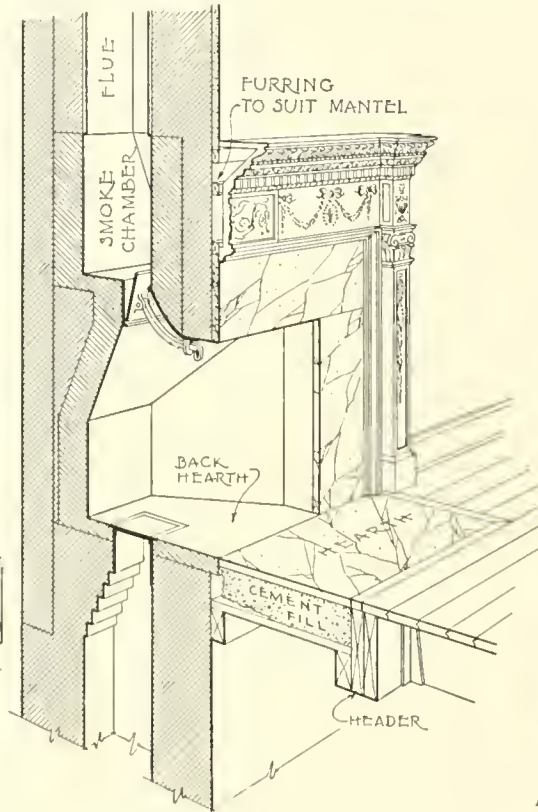

PICTORIAL SECTION THRU CENTER OF FIREPLACE, MANTEL & FLUE

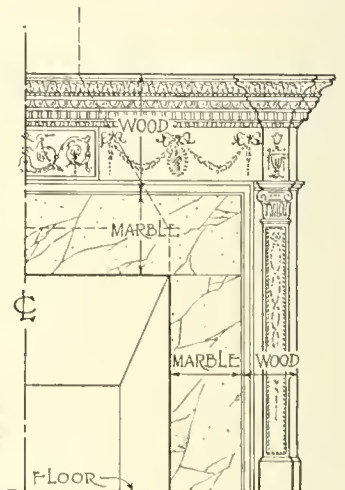

HALF ELEVATION

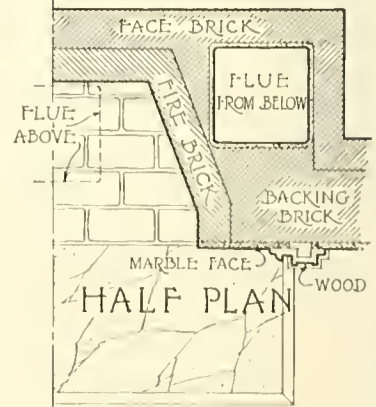

HALF PLAN

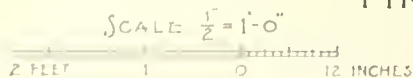

FIREPLACE DETAILS

THE FIREPLACE

The fireplace has been called the central feature of the home and as such should be given careful consideration by the architect.

The form, proportions and material must be such that the fuel for which the fireplace is designed will burn in it readily without sending gas or smoke out into the room.

Heat is thrown out by radiation, reflection and by movement of the heated air. If the side walls of the fireplace slope in as they extend back, they will reflect heat out into the room, which would not be the case if they ran straight back. Sloping the back wall as shown on **Plate 61** also helps to reflect the heat out into the room.

Any chance down-draft in the chimney will be arrested by the *smoke shelf* as shown by the arrows in the section, thus preventing the smoke from being driven into the room.

The amount of opening in the *throat* must vary with different conditions of the fire and atmosphere, but when wide open, must be equal in area to the flue above. To allow for adjusting the size of the throat, a *dampner* should be built into it. This is nothing more than a large simple valve for controlling the size of the throat.

All dimensions of the fireplace depend on the size of the opening into the room. At the top of **Plate 61** is a diagram of a fireplace properly proportioned and a list of dimensions for several sizes of openings.

When an *iron grate* or *basket* is to be used for burning coal, the dimensions and shape of the basket will determine to a certain extent the size and proportions of the fireplace.

All fireplaces, except those for gas, should be lined with 4 inches of fire brick.

If wood is to be the fuel, the fireplace should be about 18 inches deep.

The floor is protected from the heat of the fire by the *hearth* which is built of brick, stone, tile, etc. There are several methods of supporting the hearth, two of which are shown on the drawing. The usual method in wooden floors is by means of the *trimmer arch* as shown in the sectional view. The hearth may be carried on the joist as indicated in the pictorial section but shrinkage of the joist will cause cracks to open up in the hearth which is not the case with the arch shown in the orthographic section.

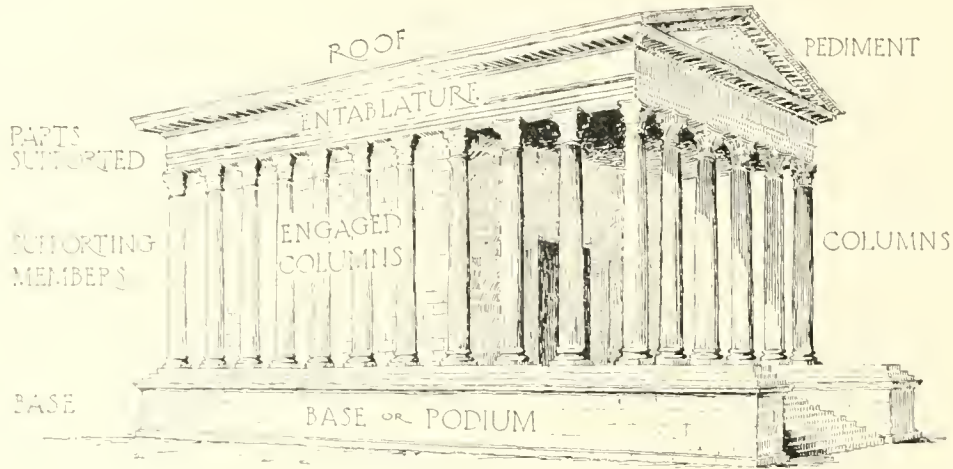

MAISON CARREE AT NIMES
ROMAN CORINTHIAN TEMPLE

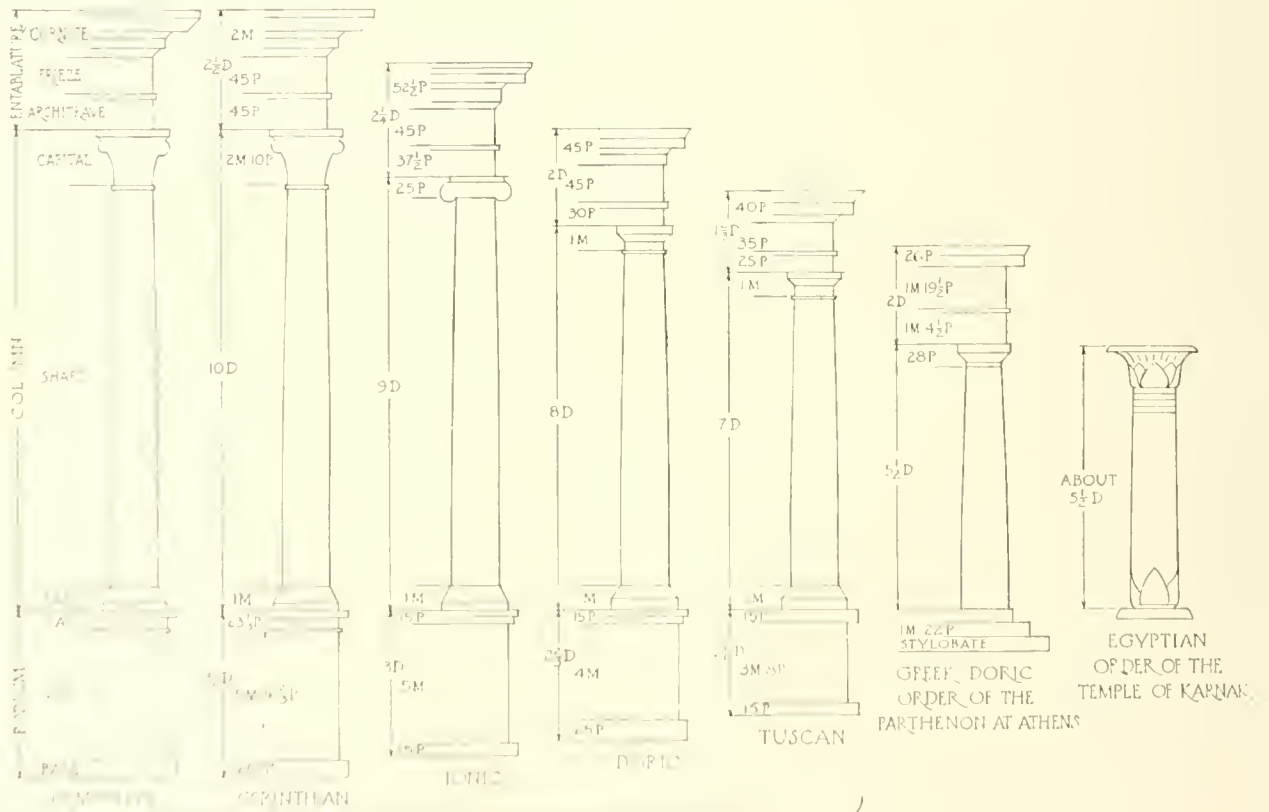

PROPORTIONS OF THE ORDERS
BY VIGNOLA

ARTICLE VII

THE ORDERS OF ARCHITECTURE

Plates 62 to 73

A building may be divided into three primary parts, a substructure or base, the supporting members and the supported part. When the supporting member is continuous it is called a *wall*, if however, the supported part is carried upon heavy, more or less isolated supports, these are called *piers*. The lighter, more slender supports are called *columns*. The member which rests upon the columns or piers, spanning the space between them and carrying the parts above, is a *beam* or *lintel*, and when the lintel is the direct support for a roof, it, together with the overhanging part of the roof, is called an *entablature*. The wall in a pediment is known as the *tympanum*.

That ornamented columns were made use of many centuries before Christ has been proven by the discoveries of archaeologists. The form and proportions of these supports were gradually improved until, in the classic temples, they reached the height of their development.

Many examples of these classic columns are in existence today together with their entablatures, bases, etc. These have been measured carefully and drawn up, making them available to the designer.

The classic column consists of a *shaft* which is ornamented at the top by a *capital* and at the bottom by a *base*. The base is sometimes carried upon a member called a *pedestal* when short and a *podium* when continuous. The column together with its entablature identify the style of architecture of the building and is called an *Order of Architecture*.

The diagram on **Plate 62** gives the names of the various parts of the classic Orders for reference as they are used in the following text.

There are many and various examples of each of the Orders. Those given in the accompanying plates seem best to represent each Order.

Plate 62 gives a comparison of the proportions of the five Orders of Architecture as fixed by the Italian architect, Giacomo Barozzi, born at Vignola, Italy, in 1507, died 1573. The Greek Order of the Parthenon at Athens and the Egyptian Order of the Temple of Karnak are also shown.

All dimensions on the plates are given in terms of the base diameter of the shaft. This diameter is divided for convenience into two parts called *modules* and each module is divided into 30 equal divisions called *parts*.

In studying the Orders, the student should learn their principal proportions and rely on the plates only for those detailed dimensions which can not be called to mind readily. After becoming acquainted with the Orders and with the principles of design, it will be found that the details may be varied almost at will, to suit conditions.

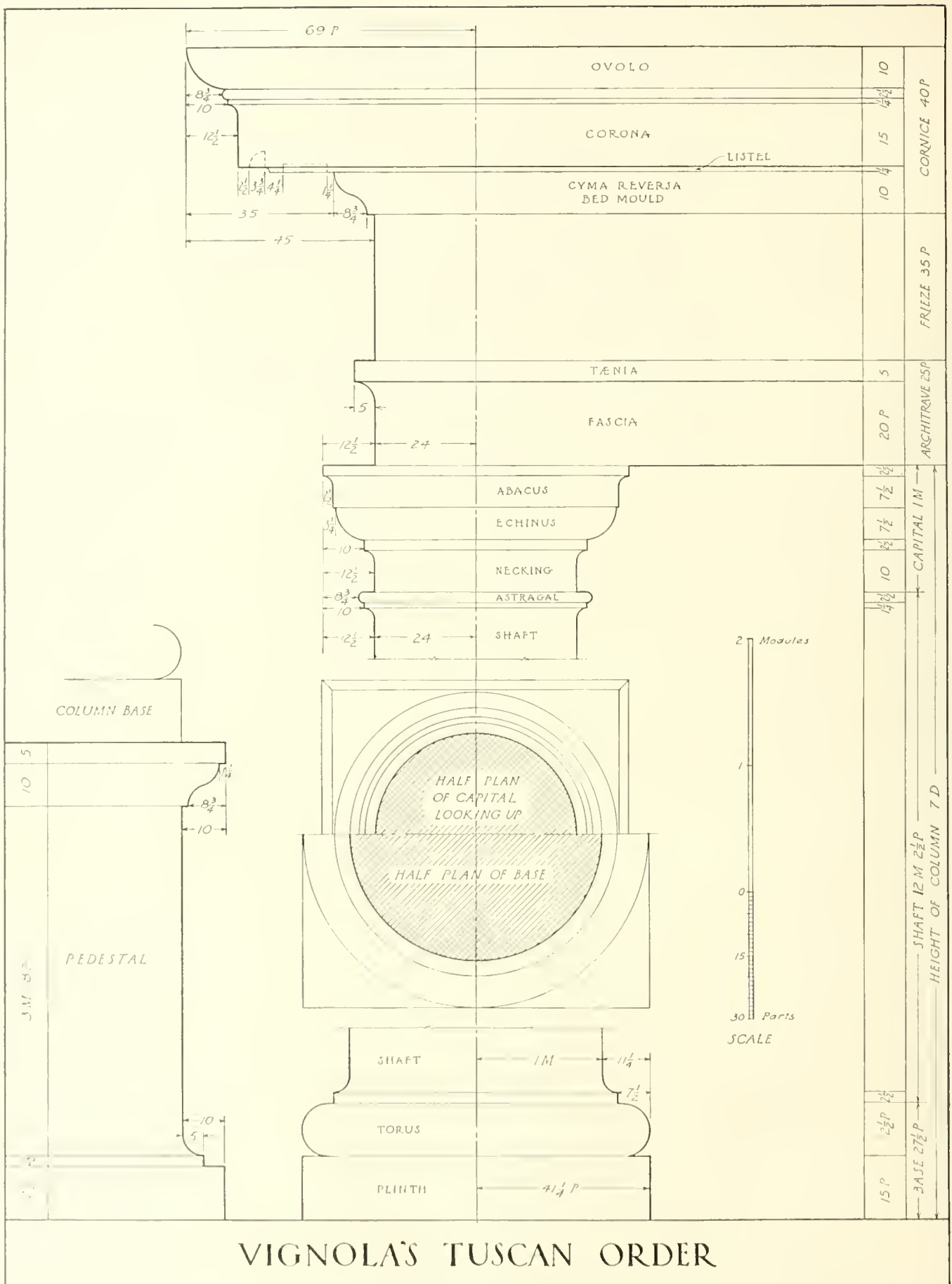

VIGNOLA'S TUSCAN ORDER

TUSCAN ORDER

The Tuscan is a Roman Order named from Tuscany, a part of Italy. It is really a simple Roman Doric being very similar to that Order except that it has no ornament and lacks the refinement of the other Roman Orders. The proportions seem to be those peculiar to timber construction rather than stone.

There are very few fragments of this Order remaining to us but several of the Italian masters have invented what they thought should be the details and dimensions of the complete Order. The best of these is probably the one invented by Vignola and is given on the opposite **Plate 63**. It is very simple and easily executed, all of the moulding profiles being made up of circle arcs and straight lines. The column shaft is not fluted and the base consists of a simple torus resting upon a perfectly plain plinth block.

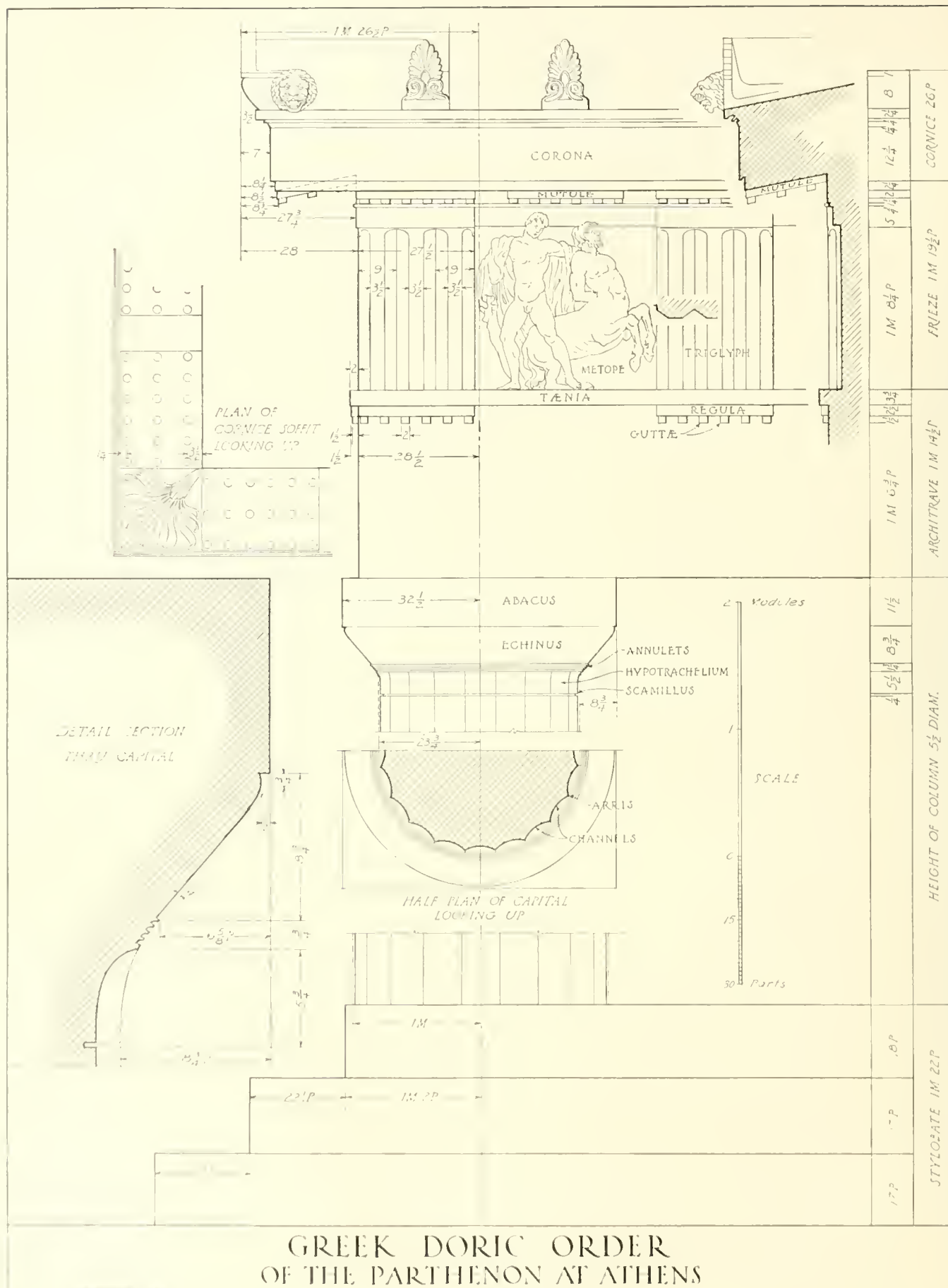

GREEK DORIC ORDER
OF THE PARTHENON AT ATHENS

GREEK DORIC

The Doric Order was probably named after the race of Dorians, a people of ancient Greece. It is the oldest of the three Greek Orders and in it is found the most subtle refinement of outline and proportion known to architecture. It is said that the proportions of man were the basis of the Doric dimensions, a man being about six times as high as the length of his foot, so the column height is about six times its base diameter.

The best example of this Order is that of the Parthenon at Athens, built about 438 B.C. The Order of the Parthenon is given on **Plate 64**.

The base of the Greek temple is called a *stylobate* and usually consisted of three large steps. The Doric column has no base, the shaft rising directly from the stylobate and having a height from $4\frac{1}{4}$ to $6\frac{1}{2}$ times its base diameter. The column usually was scored with 20 elliptical *channels* meeting in a sharp edge or *arris*. The capital is very simple and suggests great supporting strength. It consists of a heavy square slab called an *abacus* below which is an ovolo *echinus* of subtle profile. Toward the bottom of the echinus are several raised bands or *annulets* against the lower one of which the channels terminate. There is no distinct necking to this order, but in place of an astragal we find grooves on the shaft just below the echinus. These are called *scamilli*. They produce a pleasing band of shading at this point. The shaft between the annulets and the scamilli is called the *hypotrachelium*.

Most of the Greek Doric architraves are plain and very deep, and the soffits are a little less than two modules in width in the better examples. At the top of the architrave is a broad terminating fillet called the *taenia*, also a flat band called a *regula* from which are suspended the peg-like forms called *guttae* occurring beneath each *triglyph*.

The *frieze* contains a series of raised slabs called *triglyphs*, between which are square spaces called *metopes*. A triglyph occurs over the center line of each column and one centered over the space between columns. Thus the width of the metope determines the spacing of the columns. Where there is a break in the entablature as at the corner of the building the triglyph occurs at the corner and not centering over the corner column. The next triglyph then is centered between the corner one and that over the next column which makes the metopes between them slightly wider than normal. As the corner columns are usually placed closer together than the others, this difference in the metopes is not noticeable. The triglyphs are about one module in width and are scored with two vertical V shaped channels and the two corners are chamfered with a cut similar to a half channel. These channels begin down on the cap of the architrave and terminate in slightly varying forms just below the plain band cap of the triglyph. The face of the triglyph usually lines up with that of the *architrave* below, while the face of the metope is set back and usually ornamented with sculptured and painted figures. There is a plain band cap on the metope similar to that of the triglyph but not quite so wide. The corona projects about one module beyond the frieze and is about three-fourths as high as its projection. Its lower surface or *soffit* slopes up toward the building to a broad continuous band just above the frieze. The soffit is broken up by flat blocks called *mutules*, one occurring over each triglyph and each metope. On the lower surface of the mutules are *guttae* similar to those on the architrave. The crowning member of the entablature is the *cymatium* which is often richly ornamented.

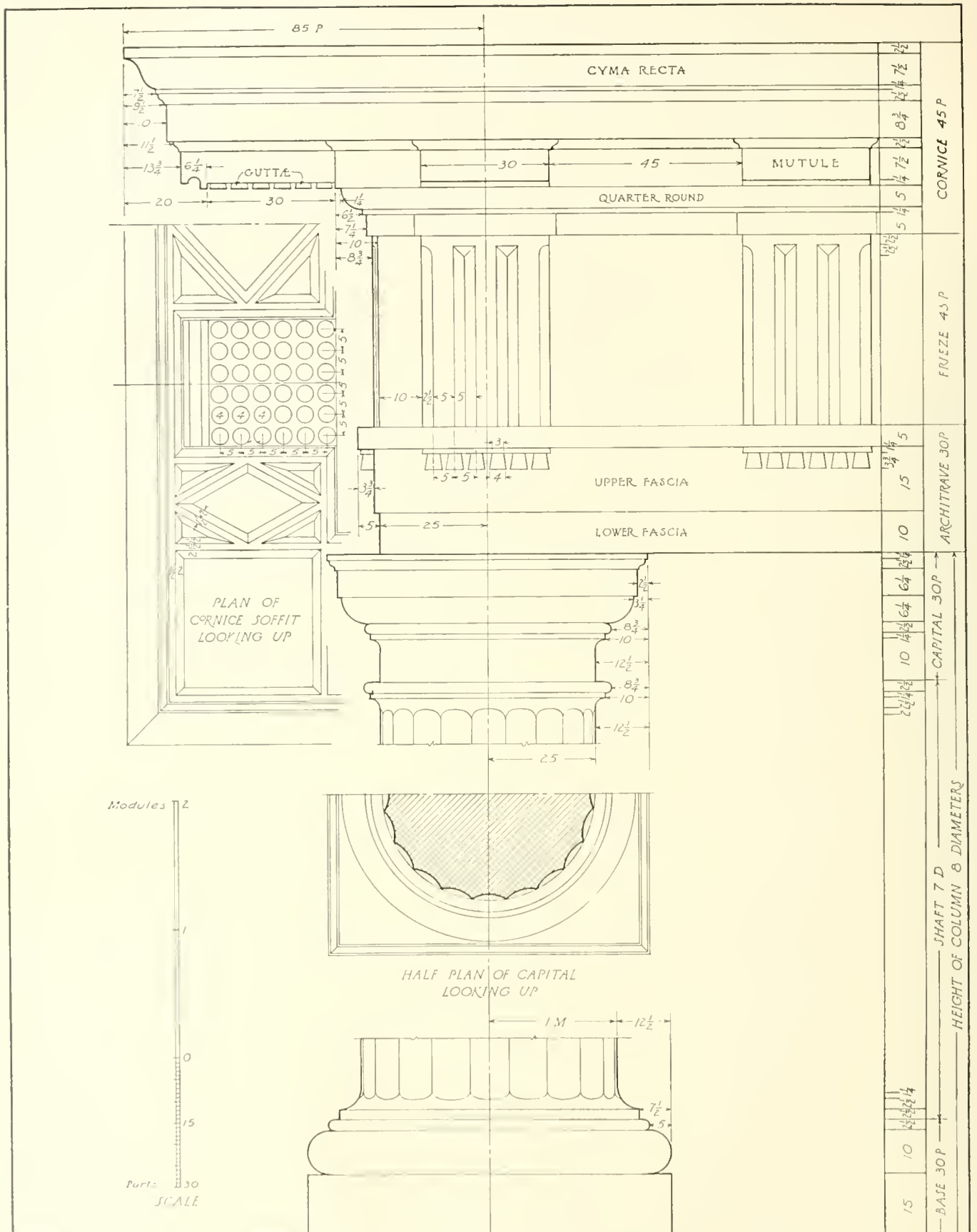

VIGNOLA'S MUTULAR DORIC ORDER

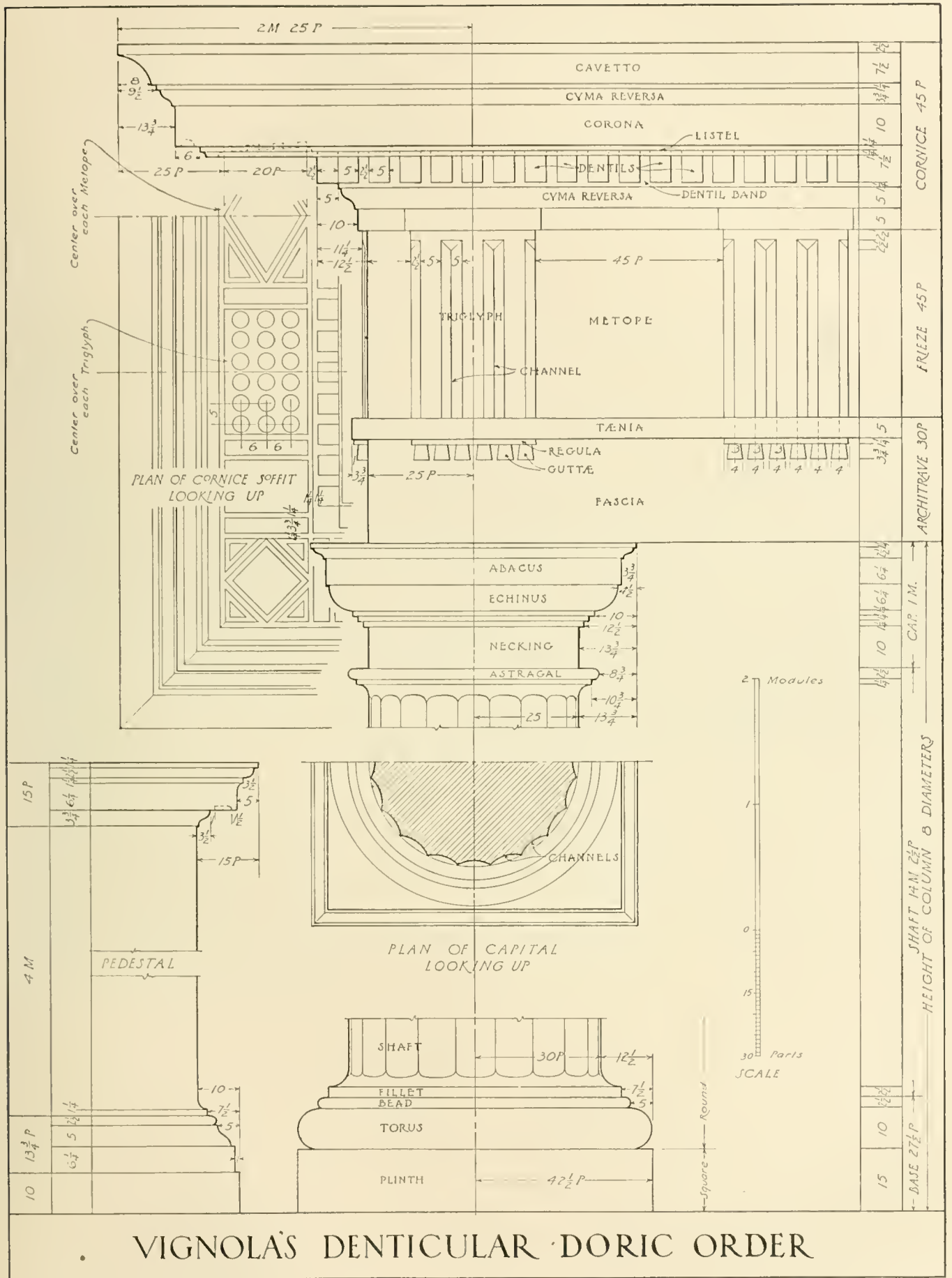

VIGNOLA'S DENTICULAR DORIC ORDER

ROMAN DORIC ORDER

In the Roman Doric we have an Order resembling the Greek Doric in a general way but having some very marked differences. Foremost among these are a general lightening of the proportions, the addition of a base to the column and an alteration of the mouldings of the capital. The Roman column has a *necking* and an *astragal* and the channels stop below the astragal. There are two distinct entablatures to this Order. One of them has the mutules similar to the Greek Doric while the other has, in place of the mutules, a series of small supporting blocks called *dentils*. The corner triglyph occurs over the center of the corner column and not at the corner of the frieze as in the Greek Order.

The best example of the Order is probably the theatre of Marcellus at Rome and it is from this that Vignola derives his Denticular Doric Order given on **Plate 66**. His Mutular Order, **Plate 65**, seems to have been inspired by that found at Albano near Rome. Another example, from the baths of Diocletian, is quite ornate and tends toward the Ionic in its detail.

IONIC ORDER

The Ionic Order, named from the Ionians of ancient Greece, is generally lighter in proportion than the Doric. It occurs in two distinct types, the Attic-Ionic and the Asiatic-Ionic, whose principal difference lies in the column base and the cornice. The base of the Attic-Ionic, **Plate 69**, consists of an upper *torus*, sometimes very large, below this a large *scotia* and at the bottom a smaller *torus* which in some instances is entirely omitted. The base of the Asiatic type consists of a *torus* resting upon a *double scotia* which is carried by a square *plinth*.

The column is from 8 to 10 diameters in height and is scored by 24 semicircular *flutes* separated by *fillets*.

The capital is the distinctive feature of the Order and there are several theories as to its origin. One of the best of these seems to be that it is the development of the conventionalized Egyptian lotus flower. In Assyria, tiles have been found on which are primitive Ionic forms; no remains of Ionic buildings have been found there however. The Ionic capital was evidently not intended for use at the corner of a building as its sides are different from the front and back. To overcome this difficulty, the Greeks placed the *volute*s of the corner columns on both of the outside faces bringing the two corner volutes together on the diagonal, as in the temple on the Ilissus near Athens. See **Plate 69**. The pillow-like rolls on the sides of the capitals back of the volutes are called *balusters* and are sometimes ornamented by flutes or foliage. In some examples are found a necking and an astragal while in others the shaft terminates under an ovolo moulding just below the cushion of the volutes.

The architrave is either plain or divided into two or three plain surfaces each projecting slightly beyond the one below. Its crowning member is a cyma moulding and fillet. The frieze is a flat surface to receive sculpture. The corona is a plain undercut member supported by a cyma bed-mould in the Attic form and by a dentil course in the Asiatic. The cymatium and its supporting moulding are often elaborately ornamented.

Since the Ionic volute is rather difficult to draw, the method of laying it out is given in detail on **Plate 68**. For small scale drawings the construction may be simplified.

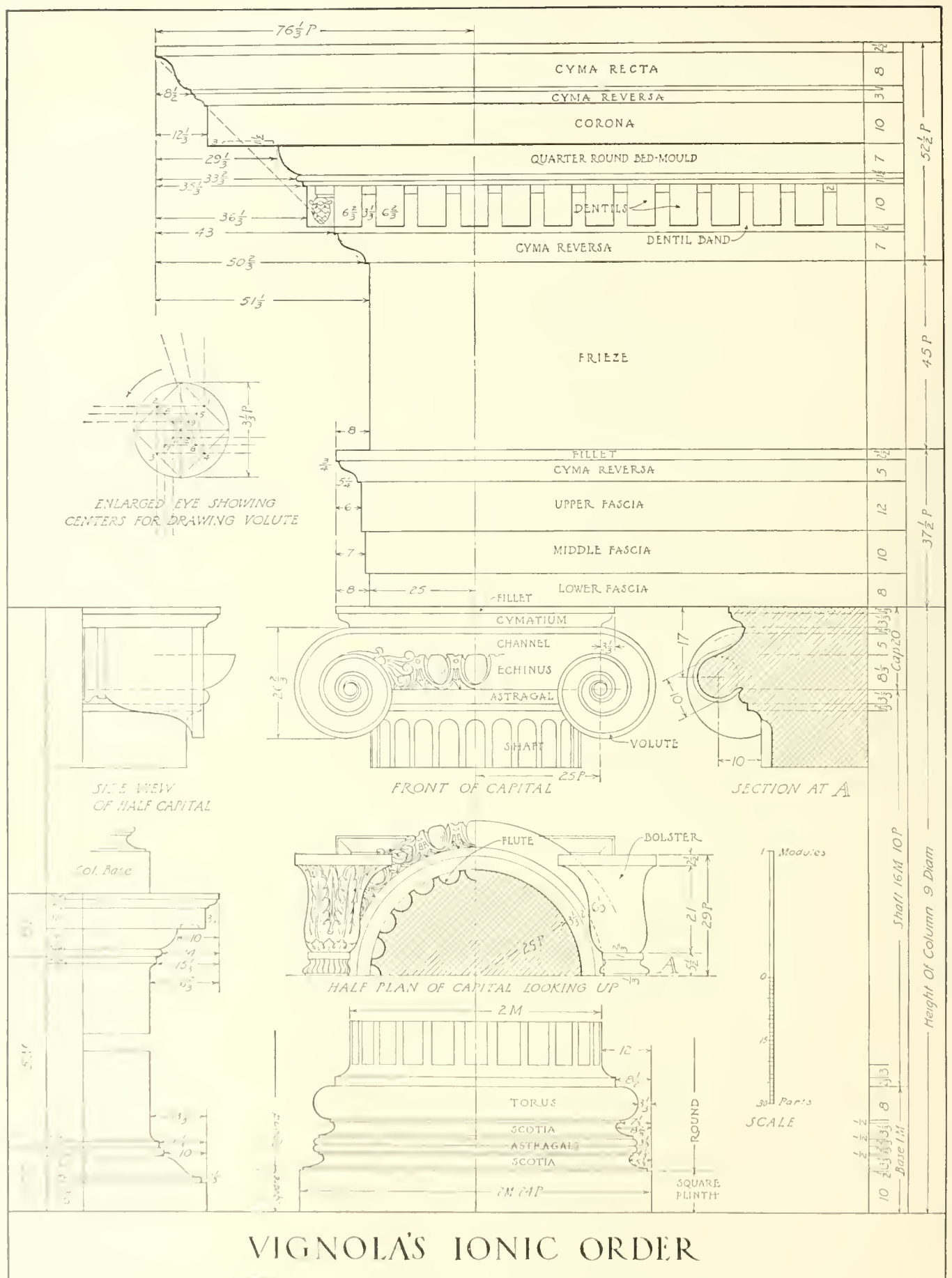

VIGNOLA'S IONIC ORDER

ROMAN IONIC

The Roman Ionic Order seems to have been borrowed from the Asiatic style. The Romans however lost the beauty of proportion and form that characterized the latter, and in its place overloaded the Order with bold ornament and made the entablature heavy and unpleasant. The cornice was usually large and supported by dentils. The mouldings were semicircular in section, lacking the refinement of those of the Greeks. The best example of this Order is that of the theatre of Marcellus at Rome, and it is from this that Vignola's Ionic, **Plate 67**, seems to have been derived. His base however is like that described by Vitruvius.

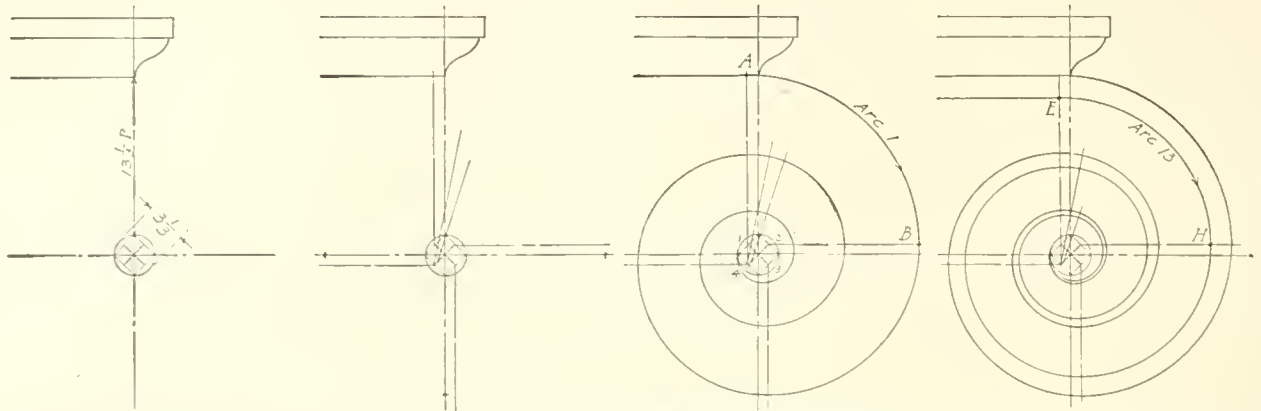

- 1-Locate vertical and horizontal center lines
- 2-Draw the eye and the square in it
- 3-Draw the two 45° lines in the square and mark off the centers on them according to the detail.
- 4-Locate the three points of intersection on the vertical and the horizontal center lines as given in the detail below.
- 5-Carefully draw the lines which locate the points of tangency of the circle arcs.
- 6-With point No.1 as a center and a radius 1-A draw arc 1 to point B. Proceed similarly with centers 2,3 etc. to center 12 which will complete the outer line of the volute.
- 7-With point No.13 as a center and a radius 13-E draw arc 13 to H.

SUCCESSIVE STAGES IN DRAWING THE IONIC VOLUTE

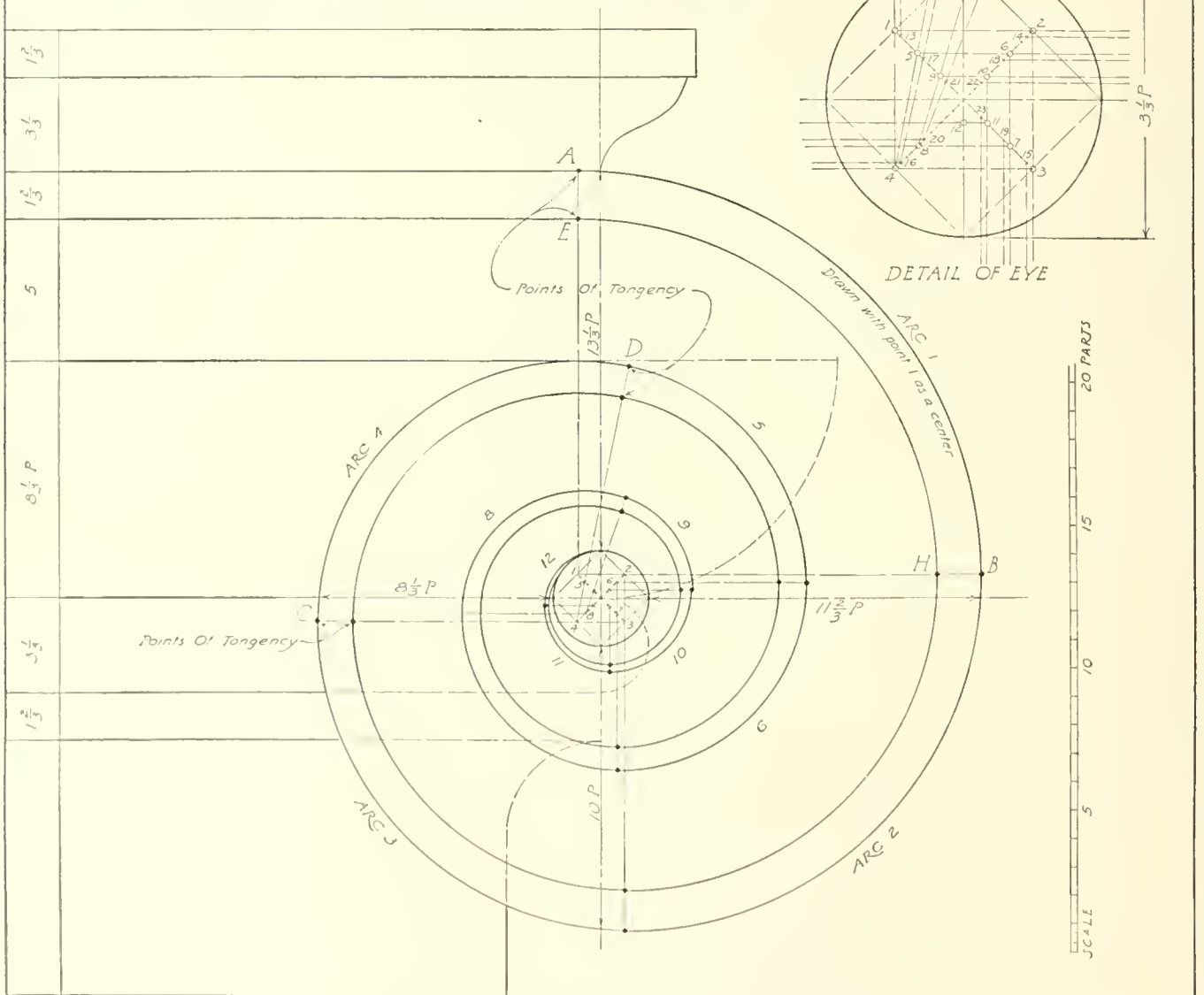

VIGNOLA'S IONIC VOLUTE

ARCHITECTURAL DRAWING

GREEK CORINTHIAN

According to Vitruvius it was the Greek sculptor Callimachos (fifth century B.C.) who, upon seeing a basket grown about with acanthus leaves, conceived the idea of the Corinthian capital. From this was developed the Greek Corinthian Order which consists of this capital used together with certain members of the Greek Ionic. The sculptors of this nation employed the acanthus leaf in a highly conventionalized form in their Order while the Roman acanthus forms were more like the natural leaf. The body of the Corinthian capital is similar to an inverted bell over the top of which is a quadrilateral abacus. This abacus has a moulded edge which curves in on each side and is cut off at an angle of 45 degrees at the corners. The bell-shaped body is separated from the shaft of the column by a torus and conge. The leaves of the capital spring up from the torus as though coming from beneath the bell and are disposed in various ways around it.

ROMAN CORINTHIAN

It was the Romans who fully developed the Corinthian Order and gave to us the typical capital. This capital contains two rows of acanthus leaves with eight leaves in either row from which spring the stems and tendrils which form the corner volutes. The lip of the bell in the Roman capital projects slightly beyond the abacus at its narrowest point while the Greek abacus entirely covers the bell. The Greek Corinthian and Ionic differ only in the capital, but the Roman Corinthian has a distinctive entablature as well. The corona is supported by a series of beam-like brackets called modillions which are ornamented with the acanthus leaf. The band from which the modillions project is in turn supported by a dentil course. The architrave is divided into several bands which are separated by small mouldings. The tendency in this Order as in the Roman Ionic was toward over-enrichment.

The Corinthian Order by Vignola is given on **Plate 70**. It was derived from various examples then existing and so no doubt is an average of the Classic Corinthian Orders.

COMPOSITE ORDER

This Order is so called because it is composed of parts of the other Orders in various combinations. It occurs in many forms, but the ones which are generally accepted under this name are made up of parts of the Ionic and Corinthian Orders. The proportions are practically the same as the Corinthian but there is much less of refinement and dignity about this Order than the others. It was usually very much over-ornamented and in some extreme examples lost almost all resemblance to the Orders from which it was developed.

Vignola's Composite, as shown on **Plate 72**, probably represents this Order at its best, but in considering it, the student must remember that it is but one of a great many varieties and marks the beginning of the end of classic excellence.

FIG. 73

FIG. 74

FIG. 75

FIG. 76

FIG. 77

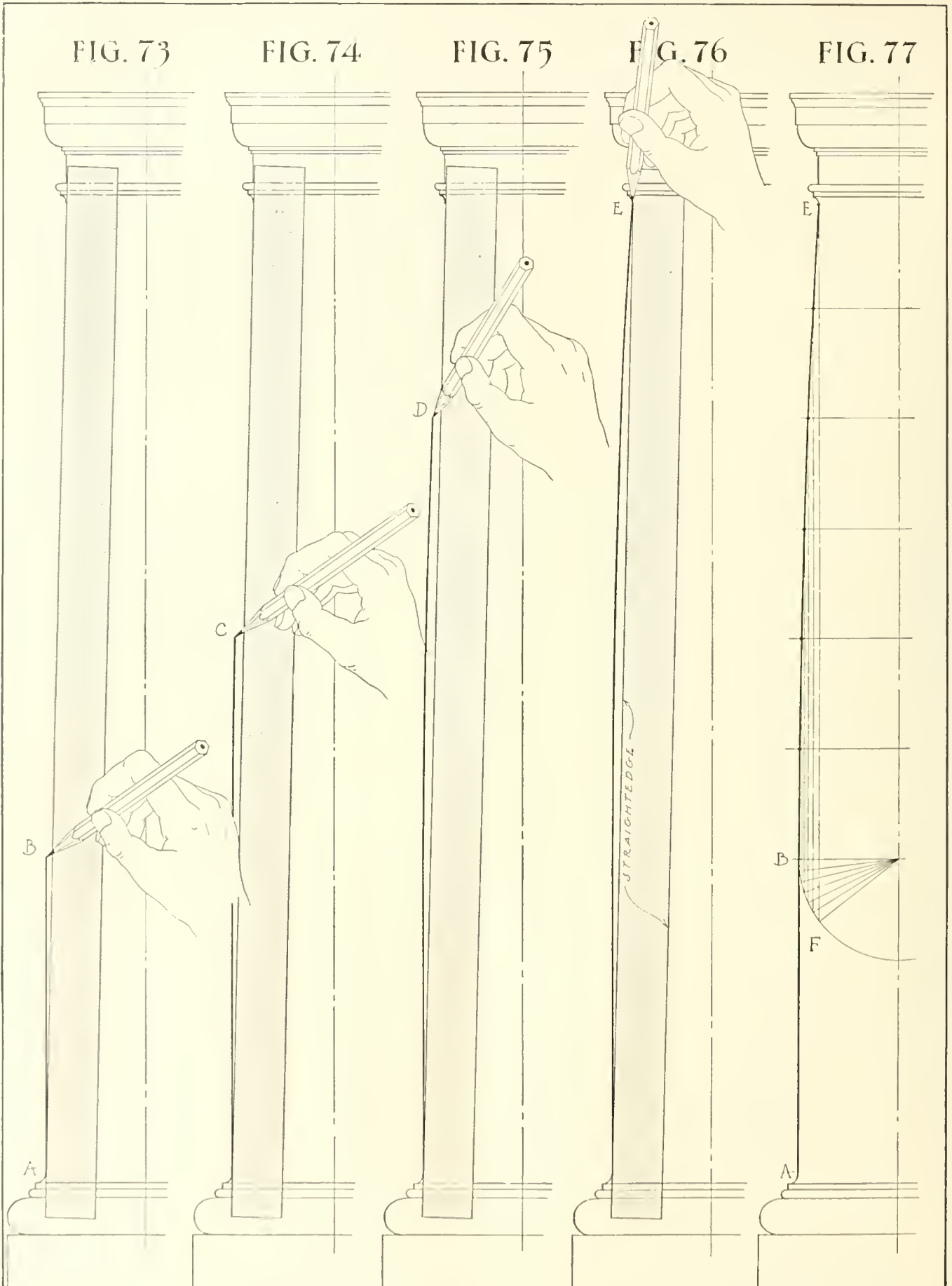

COLUMN ENTASIS

It will be noticed that the shaft of the classic column is smaller at the top than at the bottom. The diameter of the shaft does not diminish in direct proportion to the height, but in such a way as to cause an effect of swelling just above the center of the shaft. This curvature is called *entasis*. It begins one-third of the way up the shaft in most Orders, the lower third being cylindrical except in the Greek Doric shaft where the entasis begins at the bottom.

If the shaft were left straight from bottom to top, it would seem to be slightly curved *in* near the center, thereby giving to the shaft an appearance of weakness. The entasis prevents this optical effect and, at the same time, gives to the shaft a certain life which it would otherwise lack.

The entasis may be drawn on all small work, by the proper manipulation of the pencil against the straight-edge and without any construction. The method of doing this is described by Figs. 73 to 76 on **Plate 73**.

First the cap and base of the column are drawn and then the vertical part of the shaft is drawn to point *B*, Fig. 73, one-third of the distance up. The straight-edge is placed as shown and the pencil placed against the straight-edge and sloping so that the point rests on the line at *B*. Now draw the line along, at the same time throwing the point of the pencil gradually farther away from the straight-edge until location *C*, Fig. 74, is reached. From here on, the pencil is straightened up as the line proceeds. This is indicated at *D*, Fig. 75, and the pencil point is finally brought up against the straight-edge just as the line reaches point *E*. After a little practice, the student can draw a nicely curving entasis by this simple method.

For all work where greater accuracy is required and where the change in rate of curvature must be constant, the method of Fig. 77 may be employed.

Here the shaft from *B* to *E* is divided into any number of equal parts (in this case six) and the part plan of the shaft is drawn at *B*. Point *E* is now projected down to the plan at *f* and the circle arc *f-B* is divided into the same number of parts as the shaft above. From each of the points thus determined on the circle arc, project up to the corresponding line above. This will give the points through which the curving shaft line is to be drawn.

After the entasis has been thus drawn for accurate work, the shaft is dimensioned by giving the diameters at each of the horizontal lines. From such a drawing the work can be gotten out exactly as drawn.

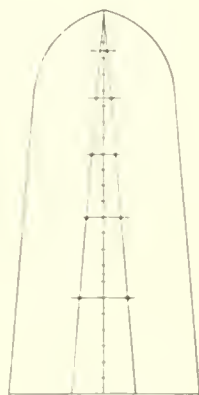
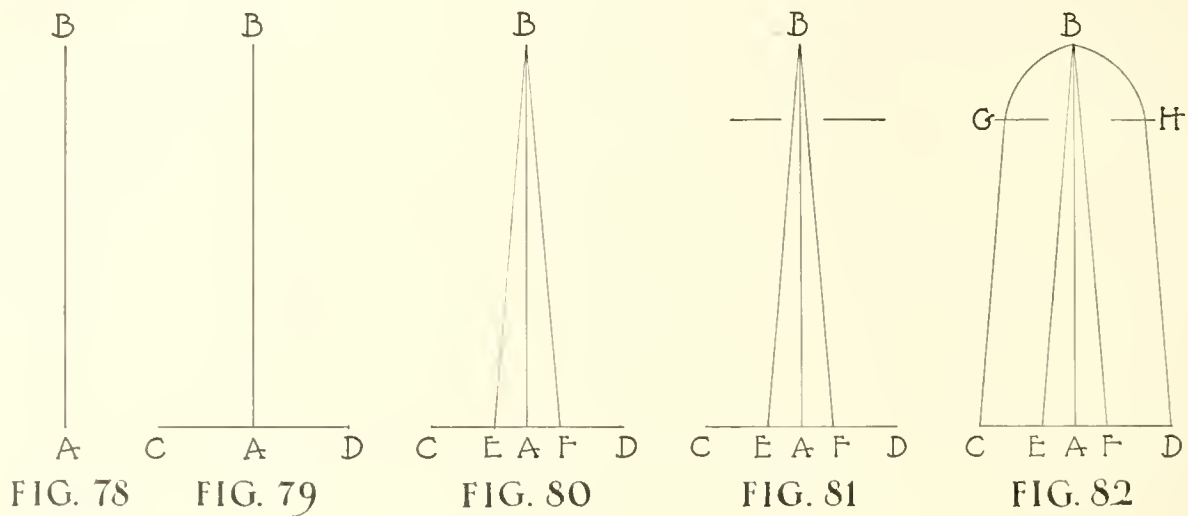

FIG. 83

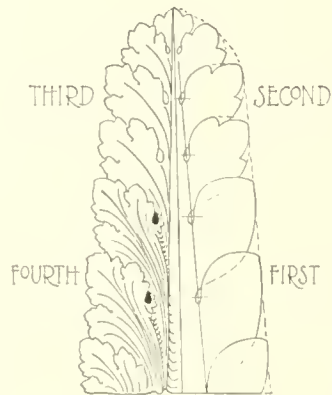

FIG. 84

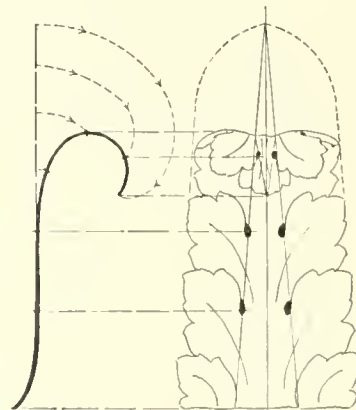

FIG. 85

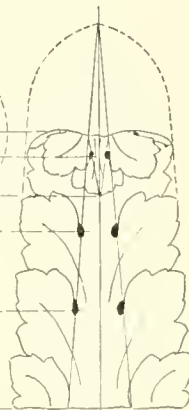

FIG. 86



FIG. 87



GREEK LEAVES

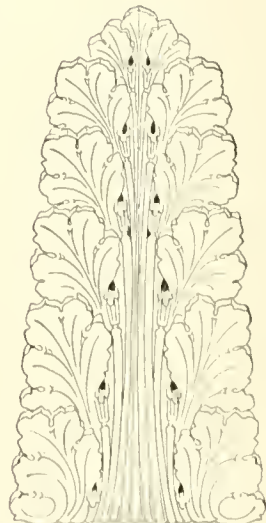
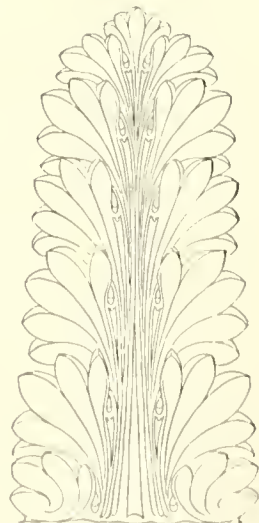

RIGHTLY MODELED BODY WITH LOBES MORE PRONOUNCED & SERRATED.

ROMAN LEAVES

ARTICLE VIII
ACANTHUS LEAF

Plate 74

Since the acanthus leaf is so often employed as architectural ornament, it is well to give here a few aids to the draftsman in laying it out.

With the basic facts in mind, one who is at all handy with his pencil should be able to achieve good results in drawing the leaf.

It will be impossible to take up each of the many architectural uses to which this leaf is commonly put, but if the fundamentals are mastered, the drawing of the leaf for any condition will be simply a matter of application.

The student should begin by laying the leaf out perfectly flat so that he may become acquainted with its forms and proportions, **Plate 74**.

Draw the vertical center line *A-B*, Fig. 78, of the desired height. This for a practice drawing might be about 8 inches. Then draw the base line *C-D*, Fig. 79, about half as long as the height. Divide *C-D* into six equal parts and mark off one part either side of the line *A-B* at *E* and *F*. Draw lines from *E* to *B* and from *F* to *B*. Measure down from *B* a distance equal to one-fifth of line *A-B* and draw the light horizontal lines either side of *A-B*. This is the spring line for the top curve of the leaf. From points *C* and *D* draw lines parallel to *E-B* and *F-B* until they meet with the above spring line at *G* and *H*. Round off the top of the leaf leaving it slightly pointed at *B* as shown. Next divide the line *A-B* into 24 equal parts and mark off on it spaces as follows, beginning at the bottom: One space 6 parts high, one 5 parts, one 4, one $3\frac{1}{2}$, one 3, and the upper one, $2\frac{1}{2}$ parts. Horizontal lines through these points locate the pistules and the starting points of each leaf.

This gives the skeleton layout of the leaf and should be memorized and followed approximately whenever the leaf is drawn. Now build up each of the leaf parts according to Fig. 84 which shows four stages of the development, and sketch in the leaf stalks or midribs between the pistules.

If a still more finished leaf is desired each leaf lobe may now be divided again into three, this for finer work which is to be viewed close up. For the average condition the fourth stage of Fig. 84 is satisfactory.

With this flat leaf in mind it will not be necessary to lay out all of the construction lines when drawing the leaf curved into the various forms with which the architect must deal. The rules will be remembered and applied unconsciously. Proportions of the leaf must of course be changed to suit the occasion.

At the bottom of **Plate 74** are typical examples of Greek and Roman leaves with a suggestion as to their distinguishing characteristics.

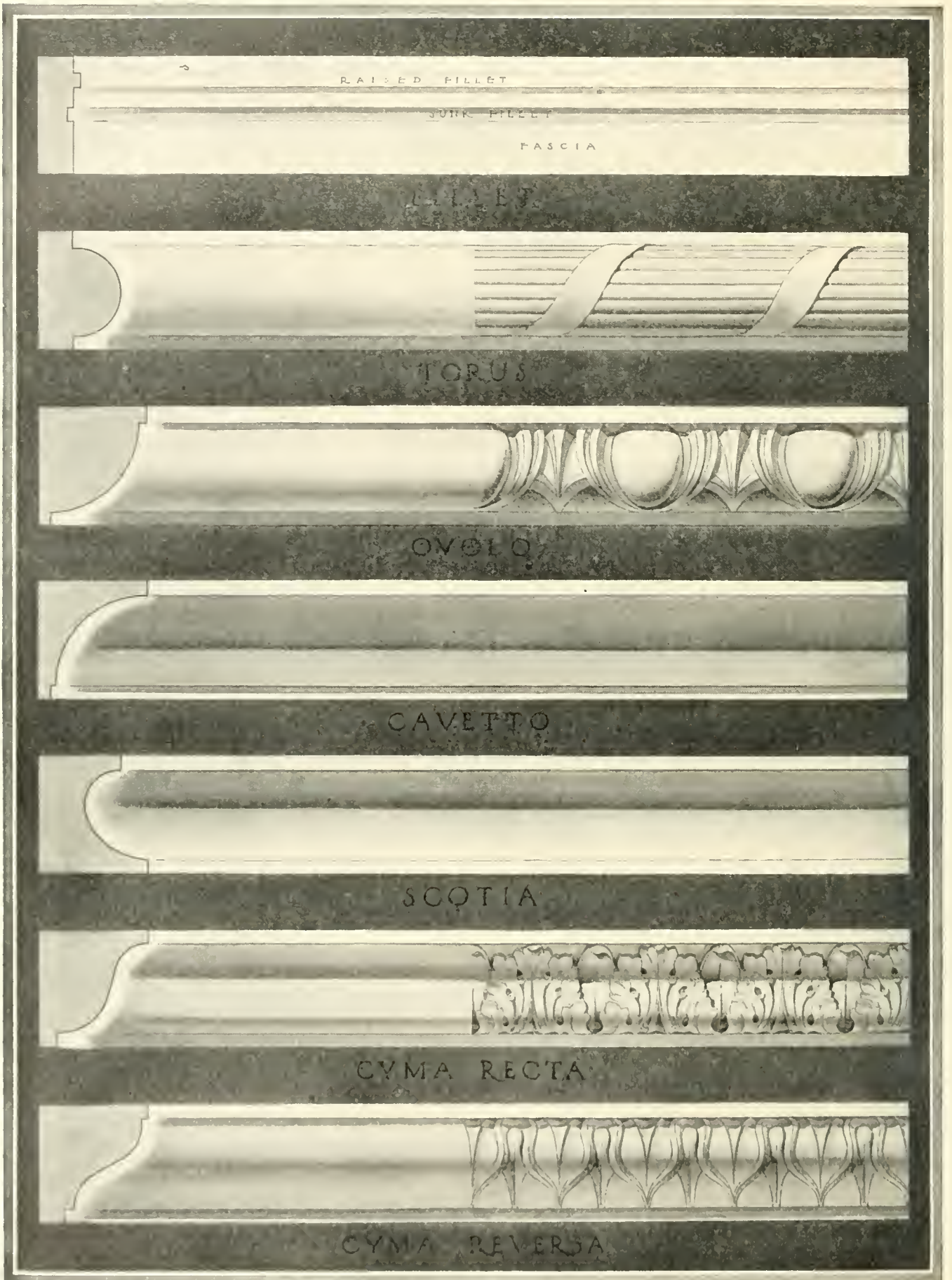

ARTICLE IX
MOULDINGS

Plate 75

Mouldings are perhaps the most important of all the devices employed by the architect for ornamental purposes. In their simplest form they produce bands of shadow varying in intensity according to the contour of the moulding. These shadow combinations may be controlled at will by the designer and are greatly enriched, when desired, by ornamenting the moulding itself.

On **Plate 75** are given the typical mouldings and the shadow effect produced by each when in the direct sunlight. When these mouldings are entirely in the shadow of some other object, their own shadow effect differs from that shown. This is because of the fact that a member in such a shadow receives reflected light from bright surfaces below. Reflected lights may be considered as coming in exactly the opposite direction from the conventional light ray as described on page 33. The effect of reflected light may be seen in the shaded portions of the given mouldings.

The accompanying plate illustrates the type of ornament typical to each of the various moulding contours. It will be noticed that in each case the ornament echos in a way the profile of the moulding. Thus the ornamental egg is similar in shape to the Ovolo, the graceful waving leaf to the Cyma, the bundle of reeds to the Torus, etc.

A study of **Plates 62 to 72** will show how uninteresting the Orders would become if the mouldings were omitted; it will also give the student some idea as to the importance of mouldings in architectural design.

The scale of a moulding, or the degree of fineness with which its parts are designed, is largely dependent upon the material in which it is to be executed. Thus mouldings in stone must of necessity be bolder than those in wood. Finer mouldings may be run in hard, close-grained woods than in those of coarser texture, and mouldings in metal may be designed on as small a scale as desired. The method of producing the moulding must also be considered by the designer, as this has a definite bearing on the design. A wooden moulding, if undercut, can not be made in one piece by machinery. When such a moulding is to be used, it must be made in parts, which is not desirable, or else by hand. In the latter case the cost usually makes its use impracticable. Study carefully the effects of light and shade on the many surfaces of the ornamented mouldings.

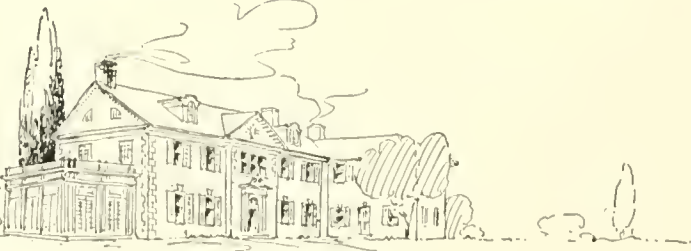
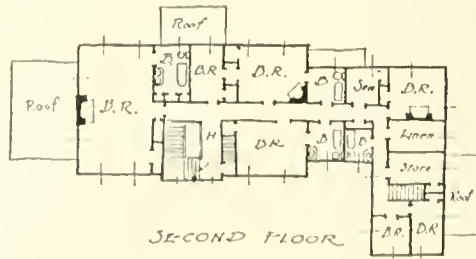
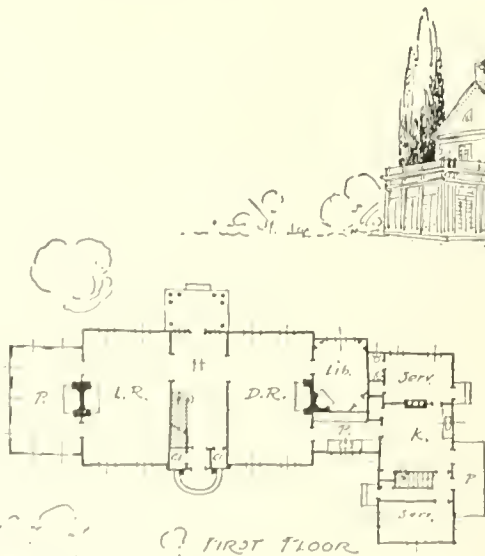
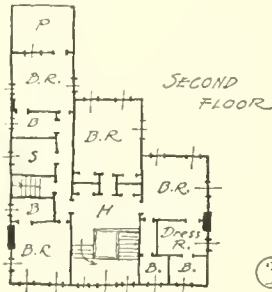
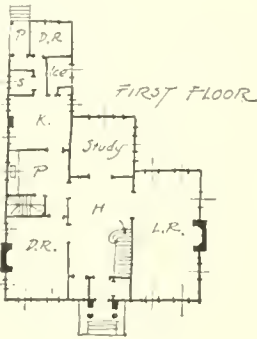
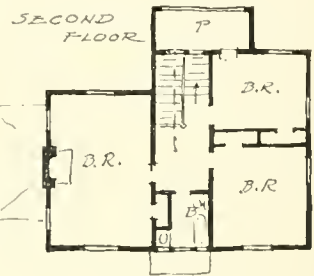
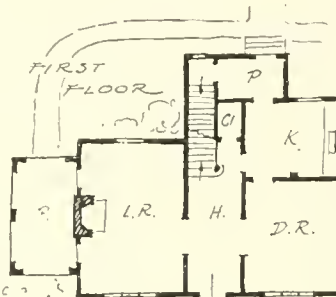
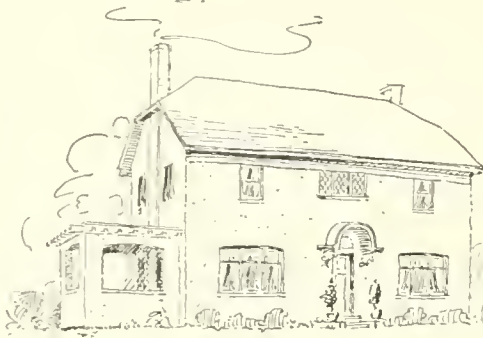
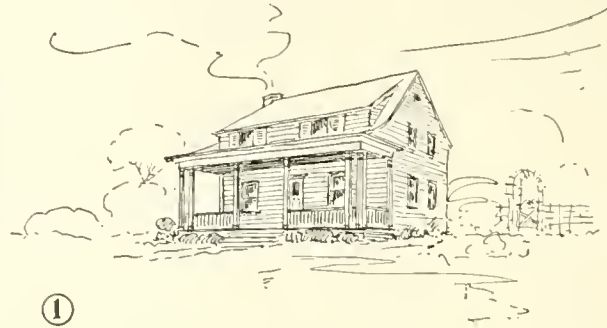
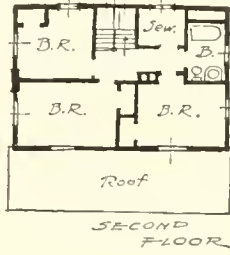
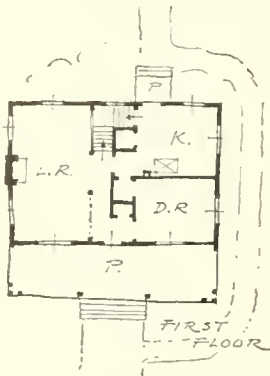

ARCHITECTURAL
LETTERING

A B C D
 E F G H I
 J K L M N
 O P Q R
 S T U V
 W X Y Z

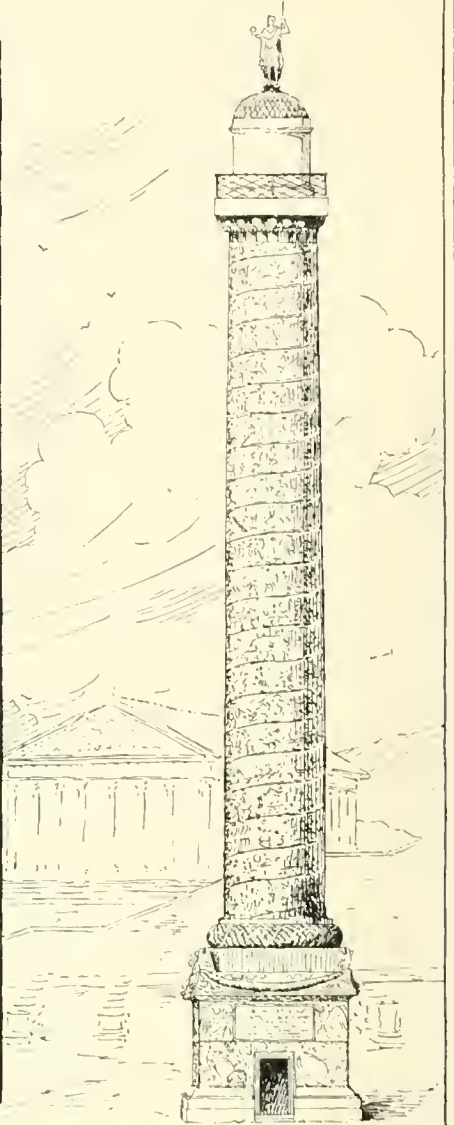

SENATVS POPVLVSQVE ROMANVS
 IMP CAESARI DIVI NERVAE F NERVAE
 TRAIANO AVG GERM DACICO PONTIF
 MAXIMO TRIB POT XVII IMP VICOS VIPP
 ADDECLARANDVM QVANTAE ALTITVDINIS
 MONSETLOCVSTANEBVS SITE GESTVS

ARTICLE X

LETTERING

Plates 77 to 84

A study of the subject of lettering is important to the architect for two reasons. The first and commonest is that he may add to his drawings necessary information in the form of titles, notes and dimensions, which must be done in a rapid legible style, conforming to the character of the drawing. The second and more important reason is that he may be able to apply it in correct and pleasing form as a branch of design. He is frequently required to include lettering as part of a design or ornament, to be executed in stone or bronze or other material. Such design must be in harmony with the period or style of the architecture and drawn with reference to the kind of material, so that the effect produced by its execution will be both legible and beautiful.

The foundation is the same for both of these somewhat distinct divisions in the architect's use of lettering, and involves first an intimate acquaintance with the letter forms, then a study of their composition and grouping.

The lettering on working drawings is chiefly concerned with legibility and speed. The necessary skill for this class of work may be acquired by taking up a single stroke letter such as that on **Plate 80**, learning the shapes of the individual letters by practicing each separately, then combining them into words and sentences, following the rules for spacing and composition.

Lettering on display drawings requires more careful attention. The effectiveness of such a drawing may be either enhanced or ruined by the character of the lettering. On this class of work the selection of the appropriate style, the placing and display, and the execution must all have thoughtful study.

For tablets, inscriptions and the like, to be carved or cast or painted as permanent ornament, there must be an intimate knowledge of historical style and an acquaintance with the method and effect of execution in the material used.

In the history and development of formal writing and printing there will be found many varied forms of alphabets. Some of these are interesting only from the paleographical standpoint, others are valuable to the designer. It is the intention here to select from the latter a few styles of particular application to architectural work.

The Roman Letter.—The original source from which all these varied forms have evolved or descended is the Roman letter of the period of Classic Roman architecture. This letter, somewhat modified and refined, appears again in the period of the Renaissance, and the general name *Old Roman* is given to both Classical Roman and Renaissance Roman. Type based on it is called by the printers "Roman oldstyle." As it is the architect's one general purpose letter it should be given most careful study.

The finest existing example of Classical Roman is that of the inscription at the base of Trajan's column (A.D. 114). The column and its inscription are illustrated on **Plate 77**, together with a panel containing an alphabet drawn from it. The letters shown in outline do not occur on the tablet but have been supplied in conforming style to complete the alphabet.

The letters *I* and *J* were not differentiated until the sixteenth century. Hence in classic inscriptions *I* is found used as *J*. The curved *U* is also a later form, the sharp *V* being used instead on all Roman inscriptions. While the use of *I* for *J* and *V* for *U* has thus historical sanction, the effect on legibility is such that it is not recommended in modern work. Using *V* for *U* has been much in vogue

A B C D

E F G H

I J K L

M N O P

Q R R S

T U U V

W X Y

Z & 1 2

3 4 5 6

7 8 9 0

FREE TREATMENT OF FORM & COMPOSITION

INCISED

A B C D E F G H I J K L M N O P Q R S T
U V W X Y Z & 1 2 3 4 5 6 7 8 9 0
a b c d e f g h i j k l m n o p q r s t u v w x y z

A B C D E F G H I J K L M N O P Q R S T U V W X Y Z & 1 2 3 4 5 6 7 8 9 0
WHEN SPACE IS LIMITED ROMAN LETTERS ARE MADE IN COMPRESSED
FORM SOMETIMES WITH CONJONED AND MONOGRAM COMBINATIONS

SCALE DRAWINGS OF THE
OTIS TRIUMPHAL ARCH
BUILT AT ROCHESTER, N.Y.

House for
HADMON S. GRAVES, ESQ. RYE, N.Y.
*Louis R. Metcalfe, Archt.
27 East 22nd St. N.Y.*

SECTION
ILLINOIS STATE MONVMENT
VICKSBYRG NATIONAL MILITARY PARK
VICKSBYRG, MISS.
JENNEY & MYNDIE, ARCHITECTS.
CHICAGO, ILL.

ARLINGTON MEMORIAL AMPHITHEATRE
MAIN ELEVATION SCALE 1 INCH = 8 FEET

among architects, even on office drawings, but it is now looked upon as somewhat of an affectation. On United States Government buildings it is not permitted. The antique effect is preserved without injuring legibility by using the manuscript form \mathbb{U} as shown on the plate.

The Roman letter is composed of two weights of lines, and to misplace these is an inexcusable fault. The rule for their correct placing may be remembered easily by recalling that these letters were originally derived from manuscript forms, written with a broad nibbed reed pen, consequently in tracing the shape of a letter as if writing it, all down strokes will be heavy while up strokes and horizontal strokes will be light. Notice that thus all inclined strokes running downward from left to right are heavy, as *A M N V W X Y* (*Z* is the one exception to this rule of direction).

The old Roman is a *light face* letter, with the width of the heavy strokes from one-eighth to one-tenth the height of the letter, and the light strokes one-half to two-thirds this width. A very important feature in its appearance is the *serif*, or cross-mark at the end of each stroke and the *fillet* that connects it to the body of the letter.

Plates 78 and 79 give a working alphabet designed from Renaissance sources, and drawn to large size for careful study. In this alphabet the width of the stem has been taken as one-tenth the height. To show proportions each letter is drawn in a square divided into ten parts in each direction. In studying these letters it will be well to draw them in ruled squares or on coordinate paper, to a size at least as large as the copy, until the forms and proportions are very familiar. On the plates they have been arranged in alphabetical order for convenient reference, but the beginner will find it best to study the letters in related groups, starting with the straight stroke letters *I H T L E F*. Draw the outlines of the heavy strokes first, follow with the outlines of the light strokes, then draw the serifs and fillets. The inclined stroke group *A K M N V W X Y Z* should then be taken up, beginning at the left side of each letter to sketch the strokes. Observe the difference in the radii of the fillets on the two sides of an inclined stroke and also as compared to the radius used on vertical strokes. Poorly drawn fillets will inevitably spoil a letter.

O Q C G are closely related. Notice that the outside curves are circle arcs. In large letters these may be penciled with compasses, although all lettering should be inked entirely freehand. The inside curves are ellipses with their long axes tilted at an angle of about 15 degrees backward from the vertical. Never make the mistake of tilting this shading the wrong way. As indicated in outline the swash line of the *Q* may be extended *ad libitum* to fit the composition.

The next group contains the letters made up of straight lines and curves, *B D J P R U*, together with *S*, the subtlety of whose reverse curve is sometimes difficult to master. Notice that all the curves in these letters are in general similar to the *O* group in that their outside curves are circles, whose centers are indicated, and the inside ellipses are tilted. Two forms of *J R Q* and *U* are given, either of which may be used. The swash line *R* is perhaps more difficult. Its tail should have a graceful sweep, not "clubby" on the end.

The ampersand, "E," a monogram abbreviation for the Latin word "et," is made in a variety of forms, sometimes with not so much flourish to the tail.

While numbers in Roman inscriptions were always in Roman numerals, Arabic figures are often required in modern designing. Those given are of a character in keeping with Old Roman lettering. Note their comparative height in proportion to the letters.

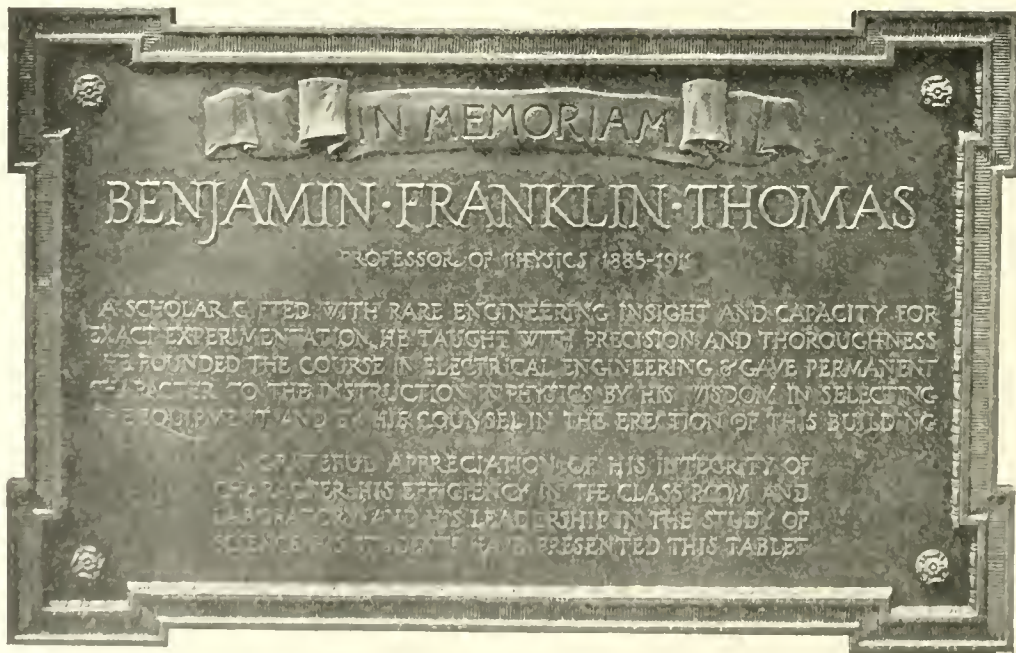

The first example on **Plate 80** shows a variation with freer treatment than the forms of the previous plates, and suitable for drawn or modeled execution rather than for carved work. In this the stems instead of having exactly parallel sides are flared slightly and the serifs are not straight lines. These variations are only "the width of a line" and must not be exaggerated, but it may be found interesting to try the effect after a thorough mastery of the straight form.

On working drawings a *single stroke* letter such as given in the third example on **Plate 80** is generally used. This letter is based on the skeleton of the Old Roman, having all its lines of the same width, and made with a single stroke of a suitable pen. For letters of the size of those in the example a ball point pen 516 F or Hunt's shotpoint 512 may be used. For smaller sizes a Gillott 404 is good. The letters should be kept to the same proportion of width to height as learned on **Plates 78** and **79**. Top and bottom guide lines should always be drawn for all lettering, no matter how small or how rapid the execution. Indeed, architects often purposely leave the guide lines on the drawings to obscure irregularities in the letters, and sometimes even ink them in with diluted ink for the same purpose.

Old Roman letters should never be extended wider than their normal proportion of width to height. They may however be made in compressed form if desired. An interesting effect is secured by keeping the round letters *C D G O Q* full, linking or conjoining them, while compressing the other letters. An alphabet and example of composition are given on **Plate 80**.

Composition in lettering involves the selection of suitable styles and sizes, the arrangement, and the spacing of letters, words and lines. Success in it depends upon artistic judgment rather than rules. One rule however is important. Letters in words are not spaced at equal distances but are made to appear uniform by keeping the irregularly shaped backgrounds between them to approximately equal area. Each letter is spaced with reference to its shape and the shape of the letter preceding it. Thus adjacent letters with straight sides would be spaced farther apart than those with curved sides. Sometimes combinations such as *LT* or *AV* may even overlap. Words should be separated by a space not more than the height of the letter. The clear distance between lines of letters may vary from one-fourth to one and one-half times the height of the letter. Much observation and practice is required before one is competent to do serious work. On **Plates 80, 81, 83** and **84** examples of composition are shown, which may be studied with profit. At the bottom of **Plate 84** the device of using Roman with wide letter-spacing is illustrated.

Titles on architectural drawings vary from the ordinary box title of a working drawing to carefully designed compositions on elaborate display drawings. Several examples are shown on **Plate 80**. The first is a full panel title, a form which is always correct and effective. To the right of it is an informal title, a style sometimes used, which has a distinct advantage in not requiring careful preliminary penciling and therefore of value for quick sketches. Below these are two formal titles, the first a balanced title and the second an enclosed title.

Working drawing titles will be found on **Plates 21, 31** and others.



UNCIAL ALPHABETS

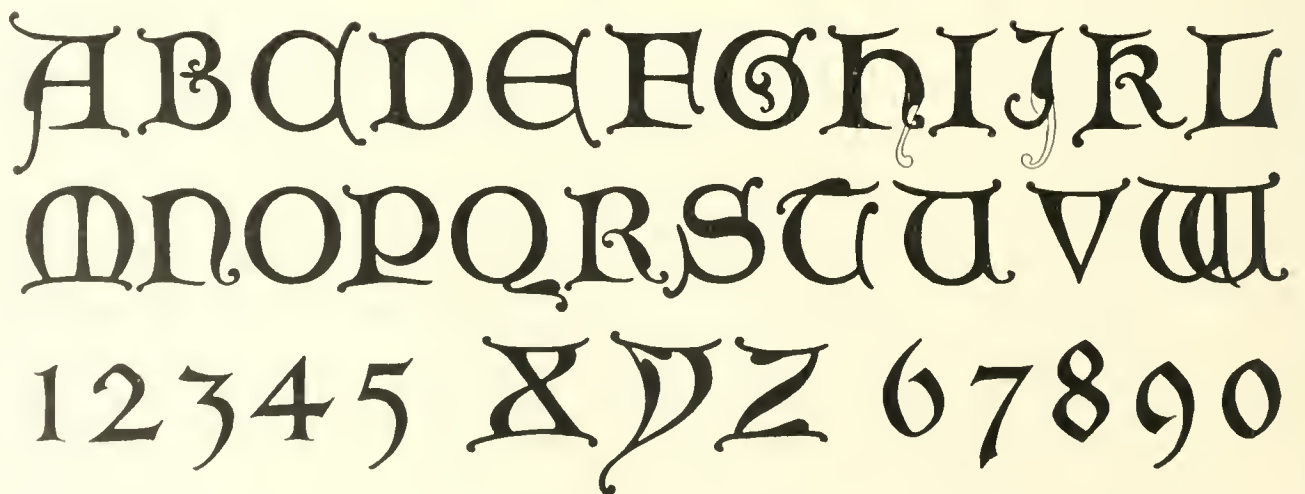

A B C D E F G H I J

K L M N O P Q R S

T U V W X Y Z & ;

1 2 3 4 5 6 7 8 9 0

abcdefghijklmnopqrstuvwxyz

tuvwxyz

abcdefghijklmnopqrstuvwxyz

Drogheda Cathedral for the
Diocese of Down & Connor
at Dullin

A B C D E F F G

H I J K L M N

O P Q Q R S T T

U V W X Y Z &

a b c d e f g g h i j k l m n

o p q r s t u v w w x y z

*French Script-a letter
appropriate for Georgian
design, often combined with*
R O M A N

In inscription lettering, the material usually being of one color, the letter is read by the shadow cast by its incised or raised body, and hence must be designed with this in mind. The heavy strokes of letters to be sunk in V form in stone should be drawn of a width not less than one-eighth of the height, with thin strokes about two-thirds of this amount. The word *INCISED* on **Plate 80** shows inscription letters whose stems are 1 to 8. Bronze tablets are made either with *flat top* or *round top* letters. Three examples are shown on **Plate 81**. The first was designed by Carrere and Hastings, the second by McKim, Meade & White and the third by the writer. All were cast by Jno. Williams Inc., New York. The letters on these tablets are 1 to 7½ or wider.

Designs for execution in stone or bronze should be made as full size details on tracing paper. For bronze castings allow one-eighth of an inch in 10 inches for shrinkage.

Uncial and Gothic.—These two historical styles of letters will be needed occasionally both in office lettering and lettering in design. They may be found appropriate in putting the titles on the display drawing of a Gothic structure, or in designing the inscription for a piece of ecclesiastical work.

These letters developed as manuscript forms, written with single strokes of a broad pen. The word *Uncial*, strictly speaking, refers to the rounded form of the early centuries of the Christian era, descending directly from the Roman, but the term as used by designers covers the later developments from it of built up or drawn capitals, particularly the Lombardic. They are sometimes used in all capitals, although not easily read when used in this form. Their chief value is as initials in connection with Gothic lower-case.

When used in carved work these letters are much more effective raised with flat top than sunk. They should never be sunk in V shape. They lend themselves well to etched brass work, either raised and polished on oxidized background, or sunk and enameled. When done in the latter method the initials and ornament are often rubricated.

Gothic capitals are more complicated in form than Uncials, and generally not so good in design. The letter known as *Old English* is to the general reader the most familiar form of Gothic. A definite rule may be given:—*Never use all caps in Gothic.*

Gothic lower-case changes from the round Gothic of the tenth century to the pointed Gothic of the twelfth to fifteenth. As a written letter it is made with a broad pen turned at an angle of 45 degrees. Large letters may be drawn in outline and filled in, or, by a skillful draftsman, may be made in single stroke with a flat brush. The one requirement in Gothic lower-case is to keep letters close together.

Plate 82 gives two Uncial (Lombardic) alphabets. The first is of simple form suitable for inscriptions, and is drawn of a size sufficiently large to show its proportions. The width of the stem here is one-sixth of the height, thus the construction square is divided into six parts each way. The second is a pen-drawn form with some of the freedom of the medieval scribe indicated. It would be suitable for painting or illuminating rather than carving.

Plate 83 gives an alphabet of Gothic capitals and corresponding lower-case, adaptable for carved work. Below this is a round, written form of Gothic lower-case, which may be made in single stroke with broad pen or flat brush. The pen-drawn Uncials of **Plate 82** should be used as capitals with this alphabet. An example of Gothic title by Bertram G. Goodhue is shown at the bottom of the plate.

Plate 84 is a slant or italic form known as French Script. It is effective for graceful, fanciful effects, but the beginner should be reminded in advance that it is difficult of successful execution.

OUTLINE OF STUDY

Plate 76

This outline will be of most value to the student who is working without the assistance of an instructor but will be found useful to the teacher as well, in laying out the work for his classes.

When the subjects are taken up in class, their order may be changed entirely from the outline or, if the following order is used, the sequence of drawings in each part may be varied to a certain extent.

The student who is working alone is usually at a loss to know just how to attack a problem or how to decide the order in which each part of the study should be made. The beginner is advised against the outright copying of the drawings of this book except in the preliminary work and perhaps the details of windows, doors, etc. It will be much better to use them as a general guide and to make the practice sheets somewhat different.

The work is divided into *Parts* and under each *Part* may be taken up as many drawings as desired. Enough should be done in each division to insure a thorough understanding of that particular step and it would be a waste of time to proceed to the next *Part* until this mental grasp is secured.

Bear this in mind: *The drawings themselves will be of no value. It is only what the student learns while making them that will be worth while.*

Preparation.—Obtain a complete drawing outfit as described on pages 9 and 10. Saw a 36-inch roll of tracing paper into two lengths of 24 and 12 inches each, these being convenient sizes for the following problems. Buy a few yards of heavy detail paper, cut a piece the size of the board and fasten it down with thumb tacks. This gives a smooth surface over which to draw even after the board has become pitted with thumb tack holes, and is easily renewed whenever necessary.

Sheet Size.—The practice sheets may of course be any size but a 13 by 18 inch sheet is a good size with which to begin. On a piece of paper slightly larger than the finished sheet is to be, draw the outline or cutting line of the sheet. Keep thumb tack holes, figuring, trial lines, etc., outside this line so that, after completing the drawing, it may be trimmed along the line and a neatly finished sheet will result. Next draw a border line around the sheet $\frac{1}{2}$ inch inside the cutting line. One of the title spaces suggested in the article on Lettering may now be added if desired but this is not necessary at present. The first few sheets may be laid out on detail paper and the tracing paper used as suggested later.

Part One.—To become acquainted with the instruments, **Plate 3**, and their use, no better exercise can be found than the drawing of a few of the geometric solutions on **Plates 4** and **5**. Divide the sheet inside the border line into four equal parts by light lines and in each space draw one solution as large as the space will permit. It might be well to draw eight of these geometric solutions or at least until one is familiar with the instruments. Bear in mind during this practice that the object is to know the instruments and to learn to work with greatest accuracy.

Part Two.—The draftsman can acquire the ability to letter well only by long continued and careful practice. Since skill in lettering is so important a part of the architectural draftsman's equipment, he should begin early in his study of the letter forms and composition, that he may acquire this practice as he works along in the other departments of the subject. Every sheet must be made a lettering exercise by carefully considering each letter, word and figure as it is drawn. Thus alone can be gained the

desired proficiency in presenting the many dimensions, notes and titles which must be used on architectural work. It will not be necessary at this time to make an exhaustive study of lettering but the single stroke Old Roman letters and figures of **Plate 80** and something about composition of letters should be learned before drawing the first plan.

On the first lettering sheet rule *very lightly*, with a sharp pencil, a number of guide lines as suggested in the article on Lettering, then practice the single stroke letters and figures, studying each carefully. Repeat them until they may be made with reasonable accuracy and speed. Draw also a few dimension lines and arrows as shown on the drawings of **Plates 21** to **30** noticing the form and proportions of the arrows.

Part Three.—On **Plate 76** are several plans and elevations which have been sketched freehand and are not drawn to any definite scale. The simplest one of these may now be drawn at a scale of $\frac{1}{4}'' = 1' - 0''$ and dimensioned. Lay out a 13 by 18 inch sheet as before and after consulting the article on Scale Drawings and studying **Plate 22** draw up and dimension the plan. This sheet should be kept quite simple and, at its completion, the draftsman should have acquired an elementary knowledge of plan symbols, drawing and dimensioning. Frequent reference to the text and plates is absolutely essential to gain the most from this sheet.

Part Four.—Fasten a sheet of tracing paper over the first floor plan which has just been completed and draw the plan of the second floor. This involves more than is at first apparent. A preliminary study of the layout of stairways must be made so that the stair of the second floor plan will tie up with that of the first floor plan. Other stair drawings will be made later but a diagrammatic section should now be made similar to that on **Plate 59**. This will aid in determining the number and location of risers and treads, which information is necessary in preparing the plan. The basement plan would ordinarily be drawn next, but it would illustrate the same points as the other two plans and so may be omitted as a practice sheet if desired.

Part Five.—Working on tracing paper over the plans, lay out the front elevation, then a side elevation as suggested by the sketch, **Plate 76**. These drawings will necessitate a study of elevations on page 50, a careful look at **Plates 21** to **30** and at the window elevations on the detail plates. Before attempting these two sheets, read again the articles on scale drawings and dimensioning and, if possible, look at a number of residence elevations in the architectural magazines. Constant reference should be made to these helps as the work progresses. The drawing of a wall section as described on page 50 should be studied carefully in connection with these sheets.

Part Six.—A scale detail of a part of the elevation may now be made at $\frac{3}{4}'' = 1' - 0''$. Select an interesting portion such as that containing the main entrance or an equally good subject. This should present about the information that is given on **Plate 28** or the Breakfast Bay of **Plate 29**. Study closely these plates and the article on page 51.

Part Seven.—Work out a typical double-hung or casement window detail depending on which type is used in the house. Study the notes accompanying the detail and try to commit the drawing to memory as the work is done. This sheet should contain drawings made at two different scales. Draw an elevation (half outside and half inside) similar to that on **Plate 49** and, beside it, a complete vertical section. Below the elevation draw a complete horizontal section or plan. These three drawings should be made at a scale of $\frac{3}{4}'' = 1' = 0''$. The larger detailed sections should be made at a scale of $3'' = 1' = 0''$.

Part Eight.—Details of the interior are next in order. They should be drawn at a scale of $\frac{1}{2}'' = 1' = 0''$ with larger scale and sometimes full-size sections of the parts where needed. An excellent exercise here would be to draw the plan of a kitchen conforming with the requirements of the Kitchen Score Card of page 17. Study also **Plate 30** and the text. After the plan is drawn, work out details of the cupboards, etc., at the scale desired.

Part Nine.—After having secured a reasonable mastery of the drawings necessary for a simple residence, the student might proceed with one more complicated or of a different material and detail. Another valuable exercise at this time would be to measure up a simple residence and make a set of drawings of it. This must be done whenever extensive remodeling is to be undertaken.

Part Ten.—The pictorial methods might well be taken up next, particularly perspective. After a study of the method, a perspective of the house previously drawn might be made.

Part Eleven.—A study of the Orders of Architecture would now give the student a knowledge of the details of more pretentious buildings. A drawing should be made of each Order and its principal proportions committed to memory. These drawings should be done on water-color paper as they make ideal subjects for practice in rendering the shades and shadows. Use Whatman's cold pressed paper, Imperial size, for this purpose. On each sheet draw the complete Order at a small scale and at as large a scale as possible draw the entablature, column capital, and base (leaving out a section of the shaft), and the pedestal. **Plate 17**, which is an example of student work, will give an idea as to how the sheet may be laid out and a suggestion for a background. The student may use his ingenuity here to produce a great variety of interesting backgrounds. In connection with a study of the Orders should come a practice sheet of the Acanthus Leaf as described on page 125 and **Plate 74**, and some attention to the Mouldings of page 127 and **Plate 75**.

Part Twelve.—The subject of Shades and Shadows, page 33, might be studied now and as many sheets devoted to its application as the student sees fit. On the first sheet draw and work out the shadows of a few simple block combinations, making use of the fundamentals as suggested on **Plate 13**. After these are understood, a more complicated object such as that of **Plate 14**, might be considered. The Orders of Architecture then make excellent subjects, for further study and practice.

Part Thirteen.—Having drawn the shadows of a few objects, the next subject for attention is Rendering. Study the text, pages 43 and 45, and follow the instructions there given as to the first practice sheet which is illustrated on **Plate 18**. Here, again, the Orders will serve as practice exercises if desired after which the student may choose such further subjects as he may fancy.

REFERENCE BOOKS

The publishers are named at the end of the list.

ACOUSTICS

Acoustics of Auditoriums.
by F. R. Watson.

ARCHITECTURAL EQUIPMENT

Sweet's Catalogue. (An extensive catalogue of architectural equipment and manufacturers.)
by Sweet's Catalogue Service, Inc., New York.

CONSTRUCTION AND SUPERINTENDENCE

Building Construction and Superintendence.²
by F. E. Kidder.
Part I. Masonry and Plastering.
Part II. Carpenter Work.
Part III. Trussed Roofs and Roof Trusses.
Elements of Structures.³
by George A. Hool.
Framed Structures and Girders.³
by Edgar Marburg.
Strength of Materials.³
by James E. Boyd.
Designing and Detailing of Simple Steel Structures.³
by Clyde T. Morris.
Architectural Engineering.⁴
by J. K. Freitag.
Reinforced Concrete.³
by Buel and Hill.
Concrete Engineers' Handbook.³
by Hool and Johnson.
Architectural Terra Cotta.⁵ (Standard Construction.)
by National Terra Cotta Society, New York.

DESIGN

Architectural Composition.⁶
by John Beverly Robinson.
The Honest House.⁷ (Small House Design.)
by Ruby Ross Goodnow.
Elements of Classic Architecture.⁸ (French.)
by Gromort.
Indication in Architectural Design.²
by David J. Varon.

Classic and Renaissance Architecture.⁹
by Joseph Bühlman.
Church Building.³¹
by Ralph Adams Cram.
Lessons in Decorative Design.¹⁰
by Jackson.
City Planning.¹¹
by Charles Mulford Robinson.

DETAILS

Building Details.¹² (Portfolios.)
by Frank M. Snyder.
Architectural Terra Cotta.⁵ (Standard Construction.)
by National Terra Cotta Society, New York.

DICTIONARY

Dictionary of Architecture and Building.¹³
by Russell Sturgis.

MECHANICAL EQUIPMENT

Condensed Catalogues of Mechanical Equipment with a General Classified Directory. The American Society of Mechanical Engineers, New York.
Chemical Engineering Catalogue. (Chemical Machinery and Supplies.) The Chemical Catalogue Company, Inc., 1 Madison Ave., New York.

DRAWING

Engineering Drawing.³ (A complete elementary treatise on orthographic projection drawing.)
by Thomas E. French.
Machine Drawing.⁶
by Carl L. Svensen.
Figure Drawing.¹⁰
by Hatton.

ESTIMATING

Contractors' and Builders' Handbook.¹⁴
by William Arthur.

FIREPROOFING

The Fireproofing of Steel Buildings.⁴
by J. K. Freitag.

ARCHITECTURAL DRAWING

HANDBOOKS

- The Architects' and Builders' Pocket Book.⁴
by F. E. Kidder.
- The Civil Engineer's Pocket Book.³²
by J. C. Trautwine.
- Mechanical Engineers' Handbook.³
by Lionel S. Marks.
- The Mechanical Engineers' Pocket Book.⁴
by Wm. Kent.
- American Electricians' Handbook.³
by Terrell Croft.
- Handbook for Electrical Engineers.⁴
by Harold Pender.
- Cambria Steel.
by Cambria Steel Co., Philadelphia, Pa.
- Carnegie Steel Companies' Pocket Companion.
by Carnegie Steel Company, Pittsburgh, Pa.

HEATING

- Hot Water Heating and Fitting.³
by Wm. J. Baldwin.

HISTORY

- GENERAL.—History of Architecture.¹⁵
by Banister Fletcher.
- History of Architectural Development.¹⁶
by F. M. Simpson.
- History of Architecture.¹⁷
by Russell Sturgis.
- History of Architecture.¹⁸
by James Ferguson.
- CLASSIC.—The Architecture of Greece and Rome.¹⁹
by W. J. Anderson and R. Phené Spiers.
- ENGLISH.—Gothic Architecture in England.¹⁵
by Francis Bond.
- Later Renaissance Architecture in England.¹⁹
by John Belcher and M. E. Macartney.
- History of Renaissance Architecture in England.²⁰
by R. T. Blomfield.
- Classic Architecture in Great Britain and Ireland, During the Eighteenth and Nineteenth Centuries.¹⁹
by A. Richardson.
- FRENCH.—The Architecture of the Renaissance in France.¹⁹
by W. H. Ward.
- Medieval Architecture.¹⁷
by A. Kingsley Porter.
- ITALIAN.—The Architecture of the Renaissance in Italy.¹⁹
by W. J. Anderson.
- History of Architecture in Italy.²¹
by C. A. Cummins.

- SPANISH.—Renaissance Architecture and Ornament in Spain.¹⁹
by A. N. Prentice.

- COLONIAL.—The Georgian Period. (A series of portfolios).
by The American Architect and Building News Company, Boston.
- The Colonial Homes of Philadelphia and Its Neighborhood.¹⁰
by H. D. Eberline.

ILLUMINATION

- The Art of Illumination.³
by Louis Bell.
- Electric Light Wiring.³
by C. E. Knox.
- Practical Illumination.³
by J. R. Cravath and V. R. Lansingh.
- Radiation, Light and Illumination.³
by Charles P. Steinmetz.

LAW

- Architect, Owner and Builder Before the Law.¹³
by T. M. Clark.

LETTERING

- The Alphabet.³⁴
by F. W. Goudy.
- Lettering.³³
by Thomas Wood Stevens.
- Letters and Lettering.²²
by Frank Chouteau Brown.
- The Essentials of Lettering.³
by French and Meiklejohn.

ORDERS OF ARCHITECTURE

- The Greek and Roman Orders.²³
by Mauch.
- Elements of Architecture.²⁴
by Pierre Esquié.
- Fragments d'Architecture Antique.²⁵
by H. d'Espouy.
- Vignola.²
by Arthur L. Tuckerman.

ORNAMENT

- The Evolution of Architectural Ornament.¹⁰
by Middleton.
- Styles of Ornament.⁹
by Alexander Speltz.
- Handbook of Ornament.²⁶
by F. S. Meyer.

ARCHITECTURAL DRAWING

The Art of Color Decoration.¹⁹

by J. D. Grace.

Garden Ornament.¹⁵

by Gertrude Jekyll.

PAINTING

The Analysis of Paints and Painting Materials.³

by Henry A. Gardner and

John A. Schaeffer.

PERSPECTIVE

Perspective. 2nd ed.⁶

by Lubschez.

Applied Perspective.²¹

by Longfellow.

Handbook of Perspective.¹⁷

by Otto Fuchs.

Modern Perspective.¹³

by Wm. R. Ware.

PIPING

A Handbook on Piping.⁶

by Carl L. Svensen.

PLUMBING

Principles and Practice of Plumbing.²³

by J. J. Cosgrove.

Plumbers', Steam Fitters' and Tinner's' Handbook.⁴

by H. G. Richey.

RENDERING

Architectural Rendering in Wash.¹⁵

by McGonigle.

Architectural Sketching and Drawing in Perspective.¹⁹

by H. W. Roberts.

Pen Drawing.²²

by Maginnis.

Architectural and Decorative Drawings.²⁶ (Examples of pen and ink rendering.)

by Bertram Grosvenor Goodhue.

Coaching Days and Coaching Ways.¹³ (Examples of pen rendering.)

by W. Outram Tristram.

Indication in Architectural Design.²

by David J. Varon.

Pencil Points (magazine). (Examples of pencil and wash rendering.)

by The Pencil Points Press Inc., New York.

Light and Shade and Their Applications.⁶

by M. Luckiesh.

A Collection of Color Prints.⁷

by Jules Guerin and Maxfield Parish.

Water Color Painting.¹⁰

by Rich.

Pencil Sketching.³⁰

by Harry W. Jacobs.

Architectural Rendering in Pen and Ink.²⁶

by Frank Allison Hays.

Fragments d' Architecture Antique.²⁵

by H. d'Espouy.

SHADES AND SHADOWS

Shades and Shadows.²²

by Henry McGoodwin.

WATERPROOFING

Modern Methods of Waterproofing.³

by Myron H. Lewis.

CURRENT ARCHITECTURAL MAGAZINES

Pencil Points

The Pencil Points Press, Inc., New York.

Architectural Record

The Architectural Record Co., 115-119 West 40th St., New York.

Architectural Forum

Rogers and Manson Co., 142 Berkeley St., Boston, Mass.

American Architect & Architectural Review

The Architectural & Building Press Inc., Stamford, Conn.

American Institute of Architects, Journal of

Am. Inst. of Architects Press Inc., 313 East 23rd St., New York.

Architecture

Charles Scribner's Sons, 597-599 Fifth Avenue, New York.

White Pine Series of Architectural Monographs

Russell F. Whitehead, 132 Madison Avenue, New York.

PUBLISHERS

1. Urbana, University of Illinois.
2. New York, The William T. Comstock Company.
3. New York, McGraw-Hill Book Company, 370 Seventh Avenue.
4. New York, John Wiley and Sons.
5. New York, National Terra Cotta Society.
6. New York, D. Van Nostrand Company, 8 Warren Street.
7. New York, The Century Company.
8. Paris, A. Vincent.
9. New York, Bruno Hessling.
10. Philadelphia, J. B. Lippincott Company, Washington Square.
11. New York, G. P. Putnam's Sons.

ARCHITECTURAL DRAWING

12. New York, Frank M. Snyder.
13. New York, The Macmillan Company.
14. New York, David Williams Company.
15. New York, Charles Scribner's Sons.
16. New York, Longmans, Green and Company.
17. New York, The Baker Taylor Company.
18. London, J. Murray.
19. London, B. T. Batsford.
20. London, G. Bell and Sons.
21. New York, Houghton, Mifflin and Company.
22. Boston, Bates and Guild Company.
23. Washington, D. C., The Reprint Company Inc.
24. Cleveland, J. H. Jansen, Caxton Bldg.
25. Paris, Charles Schmid, 51 Rue des Ecoles.
26. New York, The Architectural Book Publishing Company.
27. Boston, Ginn and Company.
28. Pittsburgh, Standard Sanitary Mfg. Company.
29. New York, The Pencil Points Press Inc.
30. New York, Scott Foresman and Company.
31. Boston, Small, Maynard and Company.
32. Philadelphia, Trautwine Company.
33. New York, The Prang Company.
34. New York, Mitchell Kennerly.

ARCHITECTURAL AND BUILDING TERMS

Abacus. The topmost division of the capital of a column. See **Plate 63**.

Abutment of an Arch. The mass of masonry which resists the thrust of the arch. That against which the ends of the arch rest.

Aisle. The side portion of a building, separated from the center portion usually by columns or piers.

Angle Iron. A structural iron shape whose cross section is in the form of a letter L.

Annulets. The band of small mouldings at the bottom of the Echinus of the Greek Doric capital. See **Plate 64**.

Antae. A pilaster attached to a wall.

Apron. The finished board placed immediately below a window stool. See **Plate 49**.

Arcade. A series of arches.

Architect's Scale. See page 9 and **Plate 3**.

Architrave of a Door or Window. The moulded finish around the opening.

Architrave of an Entablature. The lower division of the entablature. See **Plate 63**.

Arris. The edge formed by the intersecting of two surfaces.

Ashlar. The outside cut stone facing of a wall.

Astragal. A small moulding of circular section. See column capital of **Plate 63**. Also the moulding separating two doors, etc. See the sliding door of **Plate 52**.

Attic. That part of a classic structure that occurs above the cornice level. Also the space immediately under the roof of a house.

Back-band. The outside member of a window or door casing. See **Plate 49**.

Back Hearth. That part of the hearth inside the fireplace. See **Plate 61**.

Backing. The inner portion of a wall.

Balcony. A platform projecting from the building wall.

Balloon Frame. See **Plate 46**.

Base. The lower member of a column or a building.

Base Board. The finishing board covering the plaster wall where it meets the floor.

Batten. A strip of board for use in fastening other boards together.

Batter. The slope of the face of a wall that is not plumb. See **Plate 37**.

Batter Boards. Boards set up at the corners of a proposed building from which are stretched the lines marking off the walls, etc.

Bay. A comparatively small projecting portion of a building. Also one division of an arcade or the space between two columns.

Beam. A large horizontal structural member supporting floors, etc.

Bond. The connection between the bricks or stones of a masonry wall formed by overlapping the pieces.

Box Frame. A window frame containing boxes for the sash weights. See **Plate 49**.

Bridging. A cross-bracing built between joist and studs to add stiffness to floors and walls.

Building Line.—The line of the outside face of a building wall. Also the line on a lot beyond which the law forbids that a building be erected.

Building Paper. A heavy, more or less waterproof paper for use in insulating the walls, floors and roofs of buildings.

Buttress. An enlargement or projection of a wall to resist the thrust of an arch, etc.

Butts. Hinges designed to be screwed to the edge or butt of a door or window and the inside of the frame.

Camber. The convex curve of the edge of a joist or other member.

Carriage. The framing timber which is the direct support of the stair steps. See **Plate 59**.

Casement. A window whose frame is hinged at the side to swing out or in. See **Plate 51**.

Catch Basin.—A simple cast iron or cement receptacle into which the water from a roof, area way, etc., will drain. It is connected with a sewer or tile drain.

Caulicoli. The stalks which spring from the second row of leaves of the Corinthian capital and extend up to form the volutes under the corners of the abacus.

Centering. The false work upon which is built masonry arches, concrete slabs, etc. In concrete work the centering is also known as the forms.

Channel. A structural steel shape.

Client. The employer of the architect. The owner who entrusts the carrying out of his building project to the designer and engineer.

Coffer. A deeply recessed panel, usually in a ceiling or dome.

Collar Beam. A horizontal timber tying two opposite rafters together at a more or less central point of the rafters.

Colonnade. A continuous series of columns.

Console. A supporting bracket usually ornamented by a reverse scroll.

Compasses. An instrument for drawing circles.

Coped Joint. A joint between moulded pieces in which a portion of one member is cut out to receive the moulded part of the other member.

Corbel. A bracket formed on a wall by building out successive courses of masonry.

Corner Bead. A metal bead to be built into plaster corners to prevent accidental breaking off of the plaster.

Cornice. The part of a roof which projects beyond the wall. The upper main division of a classic entablature. See **Plate 63**.

Corona. The plane center member of a classic cornice. See **Plate 63**.

Court. An open space surrounded partly or entirely by a building.

Cresting. The ornamental finish of a roof ridge or the top of a wall.

Cupola. A small cylindrical or polygonal structure on the top of a dome.

Curtain Wall. A thin wall supported independent of the wall below, every one or two stories, by the structural steel or concrete frame of the building.

Cyma. One form of a moulding. See **Plate 75**.

Cymatium. The name given to a cyma moulding when it is used as a crowning moulding.

Dentils. Rectangular supporting blocks beneath the cornice of an entablature. See **Plate 66**.

Diaper. An over-all decorative pattern.

Die. The plane center member of a pedestal. When continuous it is called a Podium. See **Plate 62**.

Dividers. An instrument for stepping off equal divisions. See **Plate 3**.

Dormer. A structure projecting from a sloping roof, usually to accommodate a window. See **Plates 24** and **25**.

Drain. A means of carrying off waste water. See also House Drain.

Drip Mould. A moulding designed to prevent rain water from running down the face of a wall; used also to protect the bottom of doors, windows, etc., from leakage.

Echinus. The half-round moulded part of a column capital directly below the abacus.

Elevations. Drawings of the walls of a building, usually made as though the observer were looking straight at the wall. See page 7 and **Plate 2**.

Escutcheon Plate. The protective metal plate at a keyhole. Sometimes merely an ornamental plate around an opening.

Extradados. The name applied to the upper or outside curving line of an arch.

Face Brick. Usually a special brick used for "facing" a wall.

Fenestration. The distribution or arrangement of windows in a wall.

Finial. The ornamental termination of a pinnacle, consisting of leaf forms, etc.

Flange. The upper and lower cross parts of a steel I beam or channel. A projecting rib.

Flashing. The sheet metal work to prevent leakage over windows, doors, etc., and around chimneys and at other roof details.

Floor Plan. The horizontal section through a building showing size and location of rooms, also doors, windows, etc., in the walls.

Footing. The spread portion at the bottom of a basement wall or column to prevent settlement.

Freestone. A soft, easily worked variety of sandstone.

Fresco. Painting on fresh plaster before it has dried. Commonly, though incorrectly, used for any painting on plaster.

Frieze. That part of a classic entablature between the cornice and the architrave. See **Plate 63**.

Furring. The leveling up or building out of a part of a wall or ceiling by wood strips, etc.

Gable. The triangular portion of an end wall formed by the sloping roof.

Gable Roof. One sloping up from two walls only.

Gain. The mortise or notch cut out of a timber to receive the end of a beam.

Gambrel Roof. A roof having two different slopes such as the house of **Plate 24**.

Gargoyle. A projecting ornamental water spout to throw the roof water clear of the walls below.

Girder. A large horizontal structural member, usually heavier than a beam and used to support the ends of joists and beams, or to carry walls over openings.

Girt. The heavy horizontal timber carrying the second floor joist in a braced frame building. See **Plate 46**.

Grade. The level of the ground around a building.

Grille. A protective metal screen, sometimes highly ornamented.

Groined Vaulting. A ceiling formed by several intersecting cylindrical vaults.

Ground. Strips of wood the thickness of the plaster of a wall, secured to the framing. They aid the plasterer and afterward serve as nailing strips for securing the wood finish.

Grout. A thin mortar for filling up spaces difficult of access or where the heavier mortar would not penetrate.

Guttae. The drops used for enriching the Greek Doric Order of **Plate 64** and the Mutular Doric of **Plate 65**. They are cylindrical in the first and conical in the second example.

Gutter. A trough or depression for carrying off water.

Halving. A method of splicing the ends of two timbers by cutting half of each away and overlapping these parts. The joint is thus the same size as the timbers.

Hanging Stile. The vertical part of a door or casement window to which the hinge is fastened.

Hatching. The shading of an imaginary cut surface by a series of parallel lines. See **Plate 21**.

Head Room. The vertical clearance on a stairway or in a room. See **Plate 59**.

Hearth. The vitreous portion of a floor in front of a fireplace. See also Back Hearth and **Plate 61**.

Heel. The end of a rafter that rests on the wall plate.

Herring-bone. The name given to masonry work when laid up in a zig-zag pattern. It is usually found in brick work.

Hip-roof. One sloping up from all walls of the building.

Hood. The small roof over a doorway, supported by brackets or consoles.

House Drain. The horizontal piping beneath the basement floor of a building, which carries off the discharge from all soil and waste lines to a point outside the building.

House Sewer. The drainage pipe connecting with the house drain at a point about 5 feet outside the building and leading to the sewer or other place of disposal.

Housing. The part cut out of one member so as to receive another. See the housing of the stair step into the wall string on **Plate 59**.

Hypotrachelium. That part of the Greek Doric capital that occurs directly beneath the annulets of the echinus.

Impost. The top member of a wall, pier, etc., from which springs an arch. It may be the capital of a pier or just a moulding on a wall.

Incise. To cut into, as letters incised or carved into stone.

Intercolumniation. The clear space between columns.

Intrados. The name applied to the lower or inside curving line of an arch.

Jamb. The inside vertical face of a door or window frame.

Joist. The framing timbers which are the direct support of a floor.

Key-stone. The center top stone of an arch.

Label. The ornamental drip moulding over an arch.

Lancet Window. A high narrow window pointed like a lance at the top.

Lantern. The small structure projecting above a dome or roof for light or ventilation.

Lean-to. A small building against the side of another and having a roof sloping away from the larger structure.

Lintel. The horizontal structural member supporting the wall over an opening.

Lobby. An entrance hall or waiting room.

Loggia. A hall within a building but open on one side, this side being usually supported by a colonnade.

Lookout. A short timber for supporting the projecting cornice. See the box cornice of **Plate 55**.

Louver. A ventilating window covered by sloping slats to exclude rain.

Mansard Roof. A hipped roof having two slopes similar to the gambrel roof of **Plate 24**.

Mantel. The shelf and other ornamental work around a fireplace.

Marquetry. An ornamental surface built up of small pieces of various hard woods to form a pattern. Inlaid work.

Medallion. A round or elliptical raised surface, usually for ornamental purposes.

Meeting Rail. The horizontal rails of window frames that fit together when the window is closed. See **Plate 50**.

Metope. That part of the frieze between the triglyphs of the Doric Order. See **Plates 64, 65, and 66**.

Mezzanine. A low secondary story contained in a high story.

Mill-work. The finished wood work, machined and partly assembled at the mill.

Minaret. A Turkish turret with balconies.

Miter. A beveled surface cut on the ends of mouldings, etc., that they may meet at points where they change direction.

Modillion. An ornamental bracket supporting a cornice. See **Plate 70**.

Module. An accepted division for measuring proportions of the Orders of Architecture. It is taken as one-half of the base diameter of the column. See page 105 and **Plate 70**.

Mullion. The large vertical division of a window opening. In grouped windows it is the member that separates the sash of each unit.

Muntins. The small members that divide the glass in a window frame.

Mutules. The rectangular blocks supporting the cornice of the Mutular Doric Order. See **Plate 65**.

Narthex. A hall or lobby at the entrance of a church.

Nave. The main or central portion of a church auditorium.

Necking. The middle member of a simple column capital. See **Plate 63**.

Newel. The post where the handrail of a stair starts or changes direction.

Niche. A recess in a wall; often to accommodate a piece of statuary.

Ogee. A reverse or letter S curve. Applied also to mouldings of this section.

Oriel Window. A projecting upper story window. A small bay.

Orientation. The direction of facing of a building.

Paleography. A study of ancient inscriptions and writings.

Panel. A piece of wood framed about by other pieces. It may be raised above or sunk below the face of the framing pieces.

Parapet. That part of a wall projecting above a roof.

Parting Strip. The strip in a double hung window frame that keeps the upper and lower sash apart. See **Plate 49**.

Parts. The thirty equal divisions into which the module is divided for convenience. See page 105 and **Plate 70**.

Party Wall. A division wall common to two adjacent pieces of property.

Pendent. Usually applied to ornamental hanging parts of a Gothic vaulted ceiling.

Pendentives. The structure at the upper corners of a square building which rounds the building at the top preparatory to receiving a round dome. They may be in the form of brackets or arches.

Pent-roof. A lean-to or roof sloping one way only.

Perch. A means of measuring quantities of rubble stone. A perch contains $16\frac{1}{2}$ cubic feet.

Pier. A rectangular masonry support either free-standing or built into a wall.

Pilaster. When an attached pier becomes very high in proportion to its width, it is called a pilaster.

Piling. Wood or concrete posts driven down into soft earth to provide a safe footing for heavy loads. See **Plate 39**.

Pitch of Roof. A term applied to the amount of slope. It is found by dividing the height by the span.

Plan. See Floor Plan.

Plancher or Planceer. The soffit of a cornice or corona. See the box cornice of **Plate 55**.

Plaster Ground. See Ground.

Plate. The top, horizontal timber of a wall. The attic joist, roof rafters, etc., rest on and are secured to the plate.

Plinth. The block that forms the bottom member of a column base.

Plumb. Vertical; parallel to a plumb line.

Podium. The die or body of a continuous pedestal. See **Plate 62**.

Porch. A covered shelter on the outside of a building.

Priming. The first coat of paint or varnish, mixed and applied so as to fill the pores of the surface preparatory to receiving the subsequent coats.

Proscenium. The front part of a theatre stage including the arch over the stage.

Pulley Stile. The vertical sides of a double-hung window frame on which are fastened the pulleys for the sash weights. See **Plate 49**.

Purlins. Structural members spanning from truss to truss and supporting the rafters of a roof.

Quoins. Large cut stones at the corners of a masonry wall. They form an ornamental corner and also a stoppage for the stone or brick work of the wall proper.

Rail. The horizontal top member of a balustrade. Also the horizontal members of windows and doors. See **Plates 49** and **52**.

Raking. Inclined from the horizontal.

Random Work. Applied to stone work that is not laid up in regular order but just as the stones come to hand.

Rebate. A recessed angle to receive a window or door frame, etc. See **Plate 51**.

Regula. The plane block beneath the triglyph and taenia of the Doric Order. See **Plate 66**.

Relieving Arch. A masonry arch built over an opening to support the backing of a wall when the wall face is carried by a lintel.

Reredos. The screen behind an altar.

Return. The turning back of a moulding, belt-course, etc., into the wall on which it is located or around a corner of the building.

Reveal. The projection of a frame or moulding beyond the wall which carries it. Also the jamb of a window or door frame between the window or door and the face of the wall.

Ridge. The top edge of the roof where two slopes meet.

Rostrum. An elevated speaker's platform.

Rotunda. The circular space under a dome.

Roughcast. Stucco when thrown against the wall to form a rough finish. Sometimes applied to roughly troweled work.

Rubble. Roughly broken quarry stone.

Rubrication. The coloring of a background by paint, enamels, etc.

Ruling Pen. See page 10 and **Plate 3**.

Saddle. A small double-sloping roof to carry the water away from the back of chimneys, etc.

Salon. A large and magnificent room.

Scagliola. A plaster imitation of colored marble.

Scale. An instrument used for measurement. See page 9 and **Plate 3**. Scale in design is the feeling of size which is produced by the judicious use of familiar details such as steps, windows, etc.

Scamillus. The groove which separates the hypotrachelium or necking of the Greek Doric column from the shaft. See **Plate 64**.

Scantling. A piece of framing timber about 2 by 4 inches in section.

Scarfig. A method of lap-jointing of timbers in such a way that the joint is no larger than the section of the timbers.

Scratch Coat. The first coat of plaster which is scratched or scored to form a good bond for the second coat.

Screeds. Strips of plaster about 8 inches wide and the depth of the first two coats, which are put on first and trued up carefully to serve as guides in bringing the plastered surfaces to true planes.

Scribing. To mark or fit one edge of a board, etc., to an irregular surface.

Shaft. That part of a column between the capital and the base. See **Plates 62, 63**, etc.

Sheathing. The rough boarding on the outside of a wall or roof over which is laid the finished siding or the shingles.

Shoring. Timbers braced against a wall to form a temporary support where it is necessary to remove the wall below.

Show Rafter. A short rafter, often ornamented, where it may be seen below the cornice. See **Plate 57**.

Sill. The stone or wood member across the bottom of a door or window opening on the outside of the building. Also the bottom timber on which a building frame rests. See **Plate 46**.

Site. The location of a building.

Skew-back. The first stone of an arch, having a horizontal bottom and a sloping top face.

Skirting. See Base Board.

Sleepers. The timbers laid on a firm foundation to carry and secure the superstructure.

Slip Joint. A joint made so as to allow a certain amount of movement of the parts joined without splitting or otherwise injuring them.

Smoke Chamber. That part of the flue directly above the fireplace. See **Plate 61**.

Soffit. The underneath surface of a beam, lintel, arch, etc.

Soil Pipe. The branch pipe that connects the closet or urinal with the soil stack.

Soil Stack. The vertical pipe line that leads from the soil pipe to the house drain.

Span. The distance between supports of a joist, beam, etc.

Specifications. The written or printed description of materials, workmanship, etc., that accompany the working drawings of a building.

Standing Finish. The wood finish secured to the walls.

Stile. The vertical members of a built up part such as a door, window, panel, etc. See **Plate 52**.

Stool. The wood shelf across the bottom and inside of a window. See **Plate 49**.

String. The supporting timber at the end of stair steps. See **Plate 59**.

Stucco. Cement plaster for outside work.

Style (of architecture). The distinguishing characteristics as fixed by the Order used or by the type of roof, windows, doors, walls and other details in combination.

Stylobate. The stepped base of a Greek temple. See **Plate 64**.

Sump. A depression in a roof, etc., to receive the rain water and deliver it to the down-spout. See **Plate 55**.

Taenia. The flat division band between the architrave and the frieze of the Doric Order. See **Plate 64**.

Templet. A pattern for use in cutting irregular stones such as the voussoirs of an arch, etc.

Terrace. A raised bank of earth.

Terra Cotta. A burned clay of fine quality, much used for ornamental work on the exterior of buildings.

Thimble. The short horizontal pipe leading through a chimney wall into the flue.

Threshold. The stone, wood or metal piece directly under a door.

Throat. The opening from a fireplace into the smoke chamber. See **Plate 61**.

Tongue. A projecting bead cut on the edge of one board to fit into a corresponding groove on the edge of another piece.

Tracery. Ornamental curving bars across an opening. They usually occur in Gothic buildings and are cut from stone. See **Plate 37**.

Transom. The horizontal member which divides an opening into parts; see **Plate 51**. It is also applied to a small window built over a door.

Transom Bar. Same as the first use of Transom.

Trap. A water-seal in a sewage system to prevent sewer gas from entering the building.

Tread. The horizontal board or surface of a step.

Trellis. An ornamental lattice made up of wooden strips to support vines.

Triangle. One of the drawing instruments described on page 9 and **Plate 3**.

Triglyph. A grooved plate, ornamenting the frieze of the Doric Order. See **Plates 64, 65**, and **66**.

Trim. The finishing frame around an opening.

Trimmer Arch. The supporting arch beneath a hearth. See **Plate 61**.

Truss. A framework made up of triangular units for supporting loads over long spans. See **Plate 36**.

T Square. A drawing instrument for ruling parallel horizontal lines. See page 9 and **Plate 3**.

Tympanum. The triangular portion of wall under the sloping cornice of a classic building.

Underpinning. A new part of a wall or pier, built under an existing part.

Valley. The gutter formed by the intersection of two roof slopes.

Valley Rafter. The rafter extending along under a valley.

Vault. An arched ceiling or roof.

Veneer. A thin covering of valuable material over a less expensive body.

Vent Pipes. Small ventilating pipes extending from each fixture of the plumbing system to the vent stack.

Vent Stack. The vertical pipe connecting with the vent pipes and extending through the roof. It carries off the gasses and prevents the water-seal from siphoning out of the traps.

ARCHITECTURAL DRAWING

Verge Boards. The boards suspended from the verge of a gable. They are sometimes highly ornamented.

Vestibule. A small entrance room.

Vista. A view down an avenue or a path between shrubbery, etc.

Volute. A feature of the Ionic capital. See **Plates 67 and 68.**

Voussoir. One of the sections or blocks of an arch.

Wainscot. An ornamental or protective covering of walls, often consisting of wood panels.

Wall Plate. See **Plate 46.**

Waste Pipe. The pipe connecting lavatories and sinks with the waste stack.

Waste Stack. The vertical pipe which conducts waste water from the waste pipes to the house drain.

Water Table. A projecting, sloping member around a building near the ground to throw the rain water away from the wall.

Weather Boarding. The finished horizontal boarding of an outside wall. See **Plate 24.**

Wing. A section of a building extending out from the main part.

Wreath. The curved portion of a hand rail as at a landing. See **Plate 59.**

Yoke. The horizontal top member of a window frame. See **Plate 49.**

INDEX

A		Center lines.	47
Abacus, <i>see</i> Orders of Architecture.		Channels of Greek Doric.	109
Acanthus leaf	125	Church door detail.	Plate 54
	Plate 74	Classic orders.	105
Acoustics, <i>see</i> Reference books.			Plates 62-73
Alphabets, <i>see</i> Lettering.		Cleveland discount building.	77
Ampersand.	135		Plates 39-45
Angular perspective.	23	Column entasis.	123
Annulets, <i>see</i> Orders of Architecture.			Plate 73
Arabic numerals.	135	Columns.	105
	Plates 78 & 79	Combination frame.	Plate 46
Architect's scale.	9	Comparison of Orders of Architecture	Plate 62
Architectural and building terms.	151-156	Compasses.	10
design, <i>see</i> Reference books.		Composite Order	121
equipment, <i>see</i> Reference books.			Plate 72
history, <i>see</i> Reference books.		Composition in lettering.	137
magazines.	149		Plates 80, 81, 83 & 84
ornament, <i>see</i> Reference books.		Cone, shadow of.	37
rendering.	43	Construction and superintendence, <i>see</i> Reference books.	
Architecture, Orders of	105	Contour line.	65
	Plates 62-73		Plate 31
Arris.	109	Contour map.	65
Artificial light, <i>see</i> Hand books on illumination.			Plate 31
Attic Ionic base	Plate 69	Conventional light ray.	33
shadows of.	Plate 14	Coordinate paper, use of.	53
Attic Ionic Order.	Plate 69	Corinthian Order	
B		Greek.	121
Balanced title.	137	Roman.	121
	Plate 80		Plates 70 & 71
Balloon frame.	Plate 46	shadows of.	Plate 17
Basement window details.	Plates 47 & 48	Cornice details.	Plates 55, 56 & 57
Battened door.	Plate 52	Cost of buildings, <i>see</i> Reference books.	
Bedrooms.	19	Current architectural magazines.	149
Bench mark.	65	Cylinder, shadow of.	37
Blue prints.	52	Cyma recta, <i>see</i> Mouldings.	Plate 75
Books, reference.	147-150	Cyma reversa, <i>see</i> Mouldings.	Plate 75
Box title.	137	Cymatium, <i>see</i> Orders of Archi- tecture.	
Braced door.	Plate 52	D	
Bristol board.	10	Denticular Doric Order	112
Bronze letters.	141		Plate 66
tablets.	Plate 81	Design, architectural, <i>see</i> Reference books.	
Building terms.	151-156	Detail drawings.	85
C			Plates 46-61
Casement window details.	Plate 51		
Cavetto, <i>see</i> Mouldings.	Plate 75		

INDEX

<p>Detail paper 10</p> <p>Details, scale 51</p> <p style="padding-left: 2em;">books on. <i>see</i> Reference books.</p> <p style="padding-left: 2em;">of interior 73</p> <p style="text-align: right; padding-right: 2em;">Plate 36</p> <p>Dictionary, architectural, <i>see</i> Reference books.</p> <p>Dimensioning 51</p> <p>Dimensions of furniture 19</p> <p>Dining room 16</p> <p>Dividers 10</p> <p>Door details Plates 52, 53 & 54</p> <p>Doors and windows, location of 47</p> <p>Doorways, width and height of 47</p> <p>Doric Order, Denticular 112</p> <p style="text-align: right; padding-right: 2em;">Plate 66</p> <p style="padding-left: 2em;">shadows of Plate 15</p> <p>Double hung window details Plates 49-50</p> <p>Double swinging door detail Plate 52</p> <p>Drawing board 9</p> <p>Drawing, books on, <i>see</i> Reference books</p> <p style="padding-left: 2em;">ink 10</p> <p style="padding-left: 2em;">instruments 9-10</p>	<p>Floor system, combination tile and concrete 69</p> <p style="text-align: right; padding-right: 2em;">Plate 33</p> <p style="padding-left: 2em;">reinforced concrete 69</p> <p style="text-align: right; padding-right: 2em;">Plate 33</p> <p>Floors and walls, kitchen 17</p> <p>Footing plan Plate 39</p> <p>Formal title 137</p> <p style="text-align: right; padding-right: 2em;">Plate 80</p> <p>Foundation plan, office building Plate 39</p> <p>Framing of wooden buildings Plate 46</p> <p>French curve 9</p> <p>French script 142</p> <p style="text-align: right; padding-right: 2em;">Plate 84</p> <p>Frontispiece iv</p> <p>Furniture dimensions 19</p> <p>Furniture space 19</p>
<h3 style="margin: 0;">E</h3>	
<p>Echinus, <i>see</i> Orders of Architecture.</p> <p>Egyptian Order, Temple of Karnak Plate 62</p> <p>Elevations 7-16-50</p> <p style="padding-left: 2em;">of broken ashlar 73</p> <p style="text-align: right; padding-right: 2em;">Plate 34</p> <p>Ellipse 13</p> <p>Enclosed title 137</p> <p style="text-align: right; padding-right: 2em;">Plate 80</p> <p>Entablature 105</p> <p>Entasis of column 123</p> <p style="text-align: right; padding-right: 2em;">Plate 73</p> <p>Equipment, architectural, <i>see</i> Reference books.</p> <p style="padding-left: 2em;">kitchen 17</p> <p style="padding-left: 2em;">mechanical, <i>see</i> Reference books.</p> <p>Erasers 10</p> <p>Estimating, <i>see</i> Reference books.</p> <p>Existing buildings, drawings of 53</p>	<p style="text-align: center; padding: 10px 0;"> <h3 style="margin: 0;">G</h3> </p> <p>Geometric methods 11</p> <p style="text-align: right; padding-right: 2em;">Plates 4 & 5</p> <p>Glass, window 47</p> <p>Gothic alphabet Plate 83</p> <p>Grade line 50</p> <p>Graphic methods of representation 5</p> <p style="text-align: right; padding-right: 2em;">Plates 1 & 2</p> <p>Greek Acanthus leaf Plate 74</p> <p style="padding-left: 2em;">Corinthian Order 121</p> <p style="padding-left: 2em;">Doric Order 109</p> <p style="text-align: right; padding-right: 2em;">Plate 64</p> <p>Ground line (perspective) 21</p> <p>Guide to study 143</p> <p>Guttae, <i>see</i> Orders of Architecture</p> <p>Gutter detail Plates 55-57</p>
<h3 style="margin: 0;">H</h3>	
<p style="text-align: center; padding: 10px 0;"> <h3 style="margin: 0;">F</h3> </p> <p>Fabiano paper 10</p> <p>Fillet, <i>see</i> Mouldings Plate 75</p> <p>Fire place 103</p> <p style="text-align: right; padding-right: 2em;">Plate 61</p> <p>Fireproofing, <i>see</i> Reference books.</p> <p>Floor line 50</p>	<p style="padding-left: 2em;">Hand books, <i>see</i> Reference books.</p> <p>Hand-rail, height of 97</p> <p>Hand-rail, turns Plate 59</p> <p>Head room of stairway 101</p> <p style="text-align: right; padding-right: 2em;">Plate 59</p> <p>Hearth 103</p> <p>Heating, <i>see</i> Reference books.</p> <p>Hexagon 15</p> <p>History of Architecture, <i>see</i> Reference books.</p> <p>Horizon line (perspective) 21</p> <p>Horizontal dimensions 52</p>
<h3 style="margin: 0;">I</h3>	
<p>Illumination, <i>see</i> Reference books.</p> <p>Incised letter Plate 80</p> <p>India ink 10</p>	<p style="padding-left: 2em;">India ink 10</p>

INDEX

- Influence of stock material 47
- Informal title 137
 Plate 80
- Ink 10
- Inscription lettering 141
 Plates 80 & 81
- Instruments, drawing 9-10
 Plate 3
- Introduction 1
- Ionic Order 113
 Plate 67
 shadows of Plate 16
- Ionic volute 113
 Plate 68
- Irregular curve 9
- Irregular plan, method of laying out 67
 Plate 34
- Isometric, axis 29
 drawing 5-29
 Plates 10 & 11
- lines 29
- K**
- Kitchen 19
 equipment 17
 floors and walls 17
 light and ventilation 17
 plan of 17
 score card 17
- L**
- Laws, *see* Reference books.
- Ledged door Plate 52
- Left-hand door 47
- Lettering 131
 Plates 77-84
 See also Reference books on
 lettering.
- Lettering pens 10
- Light and ventilation of kitchen 17
- Light ray, conventional 33
- Lighting, *see* Reference books on
 illumination.
- Lining of fireplace 103
- Living room 16
- M**
- Magazines, architectural 149
- Measuring in perspective 21
- Measuring up present work 53
- Mechanical equipment, *see* Refer-
 ence books.
- Methods of representation Plate 2
- Metope, *see* Orders of Architecture.
- Module 105
- Mouldings 127
 Plate 75
- Mounting drawing or water-color paper 43
- Mutular Doric Order 112
 Plate 65
- Mutules, *see* Orders of Architecture.
- N**
- Newel detail Plate 60
- Nosing of stair step 97
- O**
- Oblique axis 31
 drawing 5-31
 Plate 11
- Office building Plates 39-45
- Old English alphabets Plate 83
- Old Roman alphabet 131
 Plates 78 & 79
- Orders of Architecture 105
 Plates 62-73
- Orientation of the house 16
- Ornament on elevations 51
- Ornament, *see* Reference books.
- Ornamental mouldings Plate 75
- Orthographic projection 5
 Plates 1 & 2
- Outline of study 143
- Outside door details Plate 53
- Ovolo, *see* Mouldings Plate 75
- P**
- Painting, *see* Reference books.
- Panelled door Plate 52
- Paper 10
- Parallel perspective 25
- Parthenon, Order of Plate 64
- Pen and ink board 10
 see Lettering pens.
- Pen, *see* Ruling pen 10
- Pencil 9
- Pentagon 15
- Perspective drawing 21
 Plates 7 & 8
- angular 23
- Cochran residence Plate 9
- parallel 25
- scale of 23
- See also* Reference books.

INDEX

<p>Pictorial drawing 5 Plate 1</p> <p>Picture plane (perspective)..... 21</p> <p>Piers..... 105</p> <p>Piling plan..... 77 Plate 39</p> <p>Piping, <i>see</i> Reference books.</p> <p>Plan symbols..... Plates 19 & 20</p> <p>Plans..... 7-16 irregular method of laying out..... 67 Plate 34 of concrete and tile floor systems..... 69 Plate 33 of reinforced concrete floors..... 69 Plate 33 piling..... 77 Plate 39</p> <p>Plinth, <i>see</i> Orders of Architecture.</p> <p>Plumbing, <i>see</i> Reference books.</p> <p>Plumbing fixtures..... Plate 19</p> <p>Pointed arch..... 15</p> <p>Points and lines, shadows of..... 35</p> <p>Practice sheet..... 45 water-color rendering..... Plate 18</p> <p>Preliminary sketches..... 16 Plates 6-18</p> <p>Proportions of fireplace..... 103 Plate 61 of the Orders..... Plate 62 of stairways..... 97</p> <p>Publishers of architectural books and magazines..... 149-150</p>	<p>Roman Numerals..... 135</p> <p>Ruling pen..... 10</p> <p style="text-align: center;">S</p> <p>Scale..... 9 details..... 51 determination of..... 46 drawings..... 46 Plates 19-45 of details..... 85 of perspective drawings..... 23 of preliminary sketches..... 16 of working drawings..... 46</p> <p>Scamilli, <i>see</i> Orders of Architecture.</p> <p>Schedule of concrete girders, etc..... 69 Plate 33</p> <p>Score card, kitchen..... 17</p> <p>Scotia, <i>see</i> Orders of Architecture and..... Plate 75</p> <p>Script, French..... 142 Plate 84</p> <p>Section through stairway..... 101 Plate 59</p> <p>Sections..... 7-50 Plate 36..... 73</p> <p>Shades and shadows..... 33 <i>See also</i> Reference books.</p> <p>Shading of letters..... 135</p> <p>Shadows, conventional..... Plates 12 & 13 of cylinders, cones and spheres..... 37 of points and lines..... 35</p> <p>Single stroke letters..... 137 Plate 80</p> <p>Site plan..... 65 Plate 31</p> <p>Sketches, preliminary..... 16 Plates 6-18</p> <p>Slicing method of casting shadows..... 39 Plate 14</p> <p>Sliding door detail..... Plate 52</p> <p>Smoke shelf..... 103</p> <p>Soffit, <i>see</i> Orders of Architecture.</p> <p>Space for furniture..... 19</p> <p>Sphere, shadow of..... 37</p> <p>Stairway..... 50-97 Plate 58 details..... Plate 59</p> <p>Station point (perspective)..... 21</p> <p>Stock material, influence of..... 47</p> <p>Stone joints, indication of..... 50 Plates 24, 34 & 37</p> <p>Story height..... 50</p>
--	---

R

University of California Library
Los Angeles

This book is DUE on the last date stamped below.

4 WK DEC 2 0 1995

University of California Los Angeles



L 007 184 105 0

UC SOUTHERN REGIONAL LIBRARY FACILITY



D 001 074 175 9

