

UC-NRLF

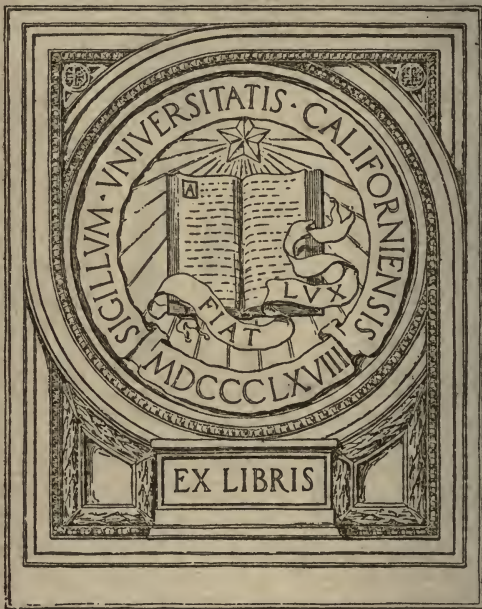

QB 530 788

GIFT OF
C. E. Tyrell



EX LIBRIS

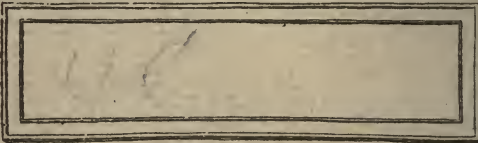

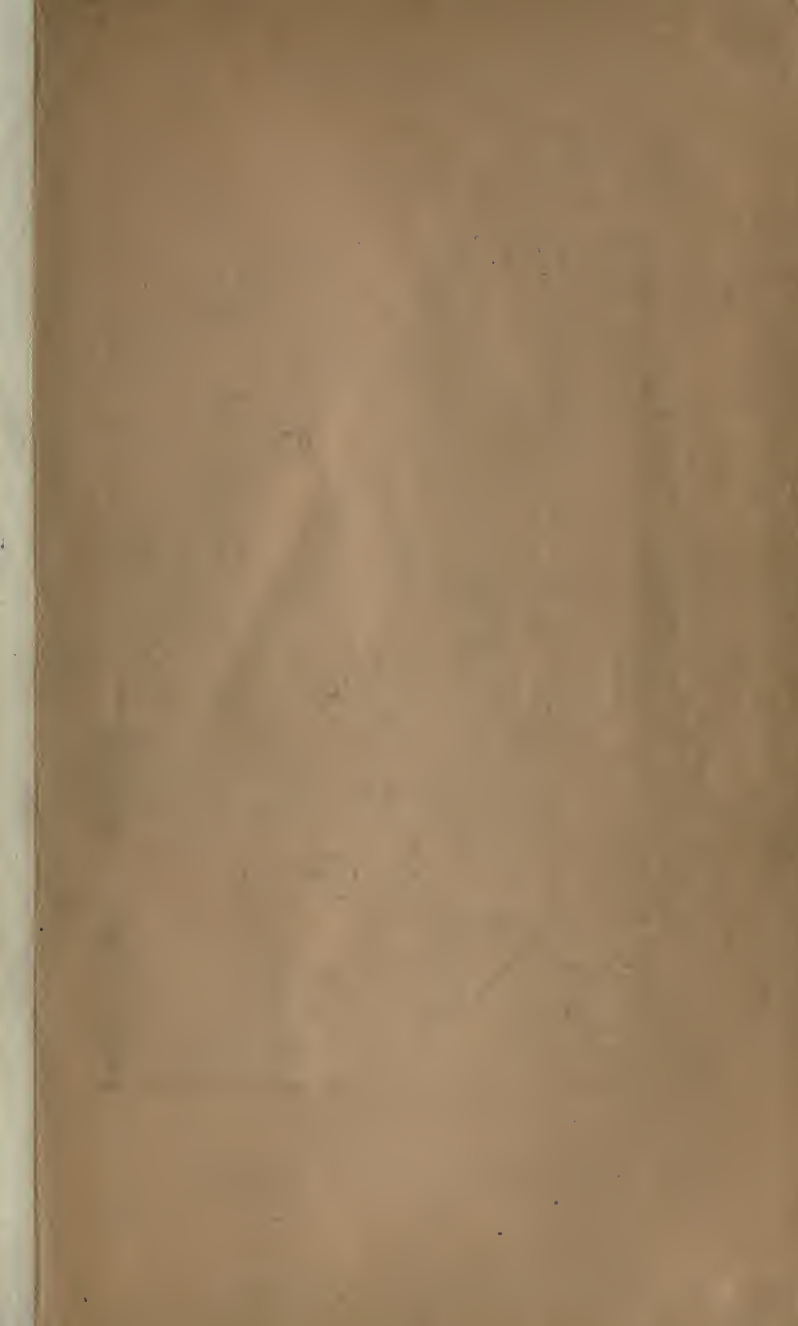

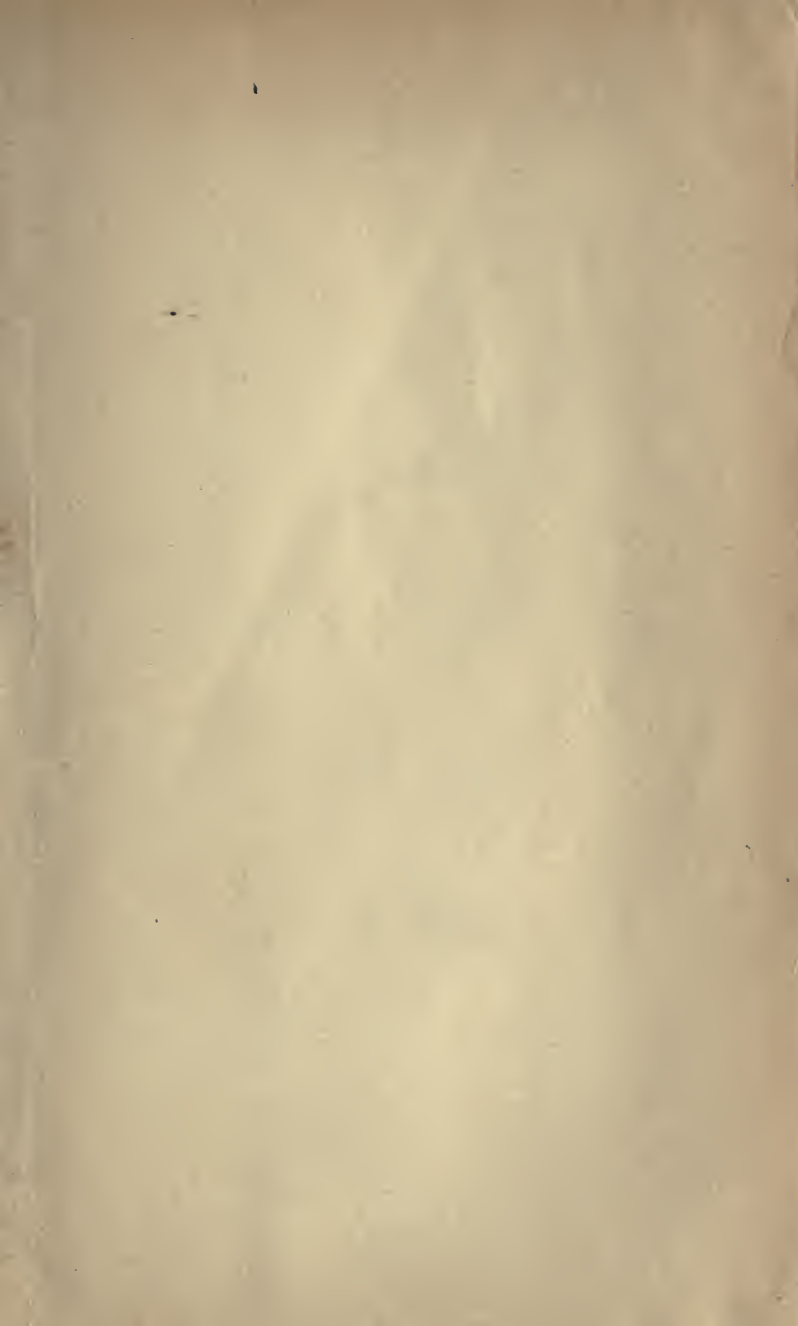



Digitized by the Internet Archive
in 2008 with funding from
Microsoft Corporation

DIFFERENTIAL AND INTEGRAL CALCULUS



THE MACMILLAN COMPANY
NEW YORK · BOSTON · CHICAGO
ATLANTA · SAN FRANCISCO

MACMILLAN & CO., LIMITED
LONDON · BOMBAY · CALCUTTA
MELBOURNE

THE MACMILLAN CO. OF CANADA, LTD.
TORONTO

A FIRST COURSE

IN THE

DIFFERENTIAL AND INTEGRAL
CALCULUS

BY

WILLIAM F. OSGOOD, PH.D.

PROFESSOR OF MATHEMATICS IN HARVARD UNIVERSITY

REVISED EDITION

New York

THE MACMILLAN COMPANY

1909

All rights reserved

QA 303

075

1909

copy of C. E. Lyell

COPYRIGHT, 1907, 1909,

By THE MACMILLAN COMPANY.

Set up and electrotyped. Published October, 1907. Reprinted
April, June, 1908.

New edition with additions, February, 1909.

373574

NO. 1011
ANNEX 1150

Norwood Press

J. S. Cushing Co. — Berwick & Smith Co.
Norwood, Mass., U.S.A.

PREFACE

THE treatment of the calculus that here follows is based on the courses which I have given in this subject in Harvard College for a number of years and corresponds in its main outlines to the course as given by Professor B. O. Peirce in the early eighties. The introduction of the integral as the limit of a sum at an early stage is due to Professor Byerly, who made this important change more than a dozen years ago. Professor Byerly, moreover, was a pioneer in this country in teaching the calculus by means of problems, his work in this direction dating from the seventies.

The chief characteristics of the treatment are the close touch between the calculus and those problems of physics, including geometry, to which it owed its origin; and the simplicity and directness with which the principles of the calculus are set forth. It is important that the formal side of the calculus should be thoroughly taught in a first course, and great stress has been laid on this side. But nowhere do the ideas that underlie the calculus come out more clearly than in its applications to curve tracing and the study of curves and surfaces, in definite integrals with their varied applications to physics and geometry, and in mechanics. For this reason these subjects have been taken up at an early stage and illustrated by many examples not usually found in American text-books.*

It is exceedingly difficult to cover in a first course in the calculus all the subjects that claim a place there. Some teachers will wish to see a fuller treatment of the geometry of special

* Professor Campbell's book: *The Elements of the Differential and Integral Calculus*, Macmillan, 1904, in its excellent treatment of the integral as the limit of a sum, is a notable exception.

curves than I have found room for. But I beg to call attention to the importance of the subject of functions of several variables and the elements of the geometry of surfaces and twisted curves for all students of the calculus. This subject ought not to be set completely aside, to be taken up in the second course in the calculus, to which, unfortunately, too few of those who take the first course proceed. Only a slight knowledge of partial differentiation is here necessary. It has been my practice to take up in four or five lectures near the end of the first year as much about the latter subject as is contained in §§ 3-9 of Chap. XIV, omitting the proofs in §§ 7-9, but laying stress on the theorems of these paragraphs and illustrating them by such examples as those given in the text; and to proceed then to the simpler applications of Chap. XV. Thus the way is prepared for a thorough treatment of partial differentiation, a subject important alike for the student of pure and of applied mathematics. This subject was given in the older English text-books in such a manner that the student who worked through their exercises was able to deal with the problems that arise in practice. But modern text-books in the English language are inferior to their predecessors in this respect.*

Multiple integrals are usually postponed for a second course, and when they are taken up, some of the things that it is most important to say about them are omitted in the text-books. It is the *conception* of the double and triple integral in its relation to the formulation of such physical ideas as the moment of inertia and the area of a surface that needs to be set in the forefront of the course in the calculus. And the *theorem* that such an integral can be computed by a succession of simple integrations (the iterated integrals) should appear as a tool, as a device for accomplishing a material end. The conception, then, of the double integral, its application to the formulation of physical concepts, and its evaluation are the things with which

* I have here to except Goursat-Hedrick, *A Course in Mathematical Analysis*, vol. I; Ginn & Co., Boston, 1904.

Chap. XVIII deals. In Chap. XIX the triple integral is explained by analogy and computed, the analytical justification being left for those who are going to specialize in analysis.

The solution of numerical equations by successive approximations and other methods, illustrated geometrically, and the computation of areas by Simpson's Rule and Amsler's planimeter are taken up in Chap. XX. In an appendix the ordinary definition of the logarithm is justified and it is shown that this function and its inverse, the exponential function, are continuous.

The great majority of problems in the calculus have come down to us from former generations, the Tripos Examinations and the older English text-books having contributed an important share.* For the newer problems I am indebted in great measure to old examination papers set by Professor Byerly and by Professor B. O. Peirce,† and to recent American text-books. It is not possible to acknowledge each time the author, even in the case of the more recent problems, but I wish to cite at least a few of the sources in detail. I am indebted to Campbell ‡ for Ex. 4, p. 181; to Granville§ for Ex. 45, p. 108; to Greenhill || for Ex. 16, p. 188; and to Osborne ¶ for Ex. 43 on p. 107.

* In particular, Williamson, *An Elementary Treatise on the Differential Calculus*, University Press, Dublin, and Todhunter, *A Treatise on the Integral Calculus*, Macmillan.

† Many of these problems have been collected and published, with others, by Professor Byerly in his *Problems in Differential Calculus*; Ginn & Co., Boston, 1895. With the kind permission of the author I have drawn freely from this source.

‡ Campbell, l.c., Chaps. XXXVI and XXXVII.

§ Granville, *Elements of the Differential and Integral Calculus*, p. 129, Ex. 47; Ginn & Co., Boston, 1904.

|| Greenhill, *A Treatise on Hydrostatics*, p. 318; Macmillan, 1894.

¶ Osborne, *Differential and Integral Calculus*, p. 129, Ex. 33; D. C. Heath & Co., Boston, revised edition, 1906. This book contains an especially large collection of exercises.

In choosing illustrative examples to be worked in the text I have taken so far as possible the same examples that my predecessors have used, in order not to reduce further the fund of good examples for class-room purposes by publishing solutions of the same. It is in the interest of good instruction that writers of text-books observe this principle.

As regards the time required to cover the course here presented, I would say that without the aid of text-books which I could follow at all closely, I have repeatedly taken up what is here given in about one hundred and thirty-five lectures, extending over a year and a half, three lectures a week. The time thus corresponds roughly to a five-hour course extending throughout one year.

To Mr. H. D. Gaylord, who has given me much assistance in reading the proof, and to Dr. W. H. Roever and Mr. Dunham Jackson, who have aided me with the figures, I wish to express my appreciation of their kindness.

CAMBRIDGE,
September 12, 1907.

CONTENTS

CHAPTER I

INTRODUCTION

ART.	PAGE
1. Functions	1
2. Slope of a Curve	5

CHAPTER II

DIFFERENTIATION OF ALGEBRAIC FUNCTIONS. GENERAL THEOREMS

1. Definition of the Derivative	9
2. Differentiation of x^n	11
3. Derivative of a Constant	13
4. General Formulas of Differentiation	13
5. Three Theorems about Limits	15
6. General Formulas of Differentiation, Concluded	21
7. Differentiation of Radicals	25
8. Continuation ; x^n , n Fractional	27
9. Differentiation of Algebraic Functions	34

CHAPTER III

APPLICATIONS

1. Tangents and Normals	37
2. Maxima and Minima	39
3. Continuation ; Auxiliary Variables	43
4. Velocity	46
5. Increasing and Decreasing Functions	49
6. Curve Tracing	51
7. Relative Maxima and Minima. Points of Inflection	53
8. On the Roots of Equations	57

CHAPTER IV

DIFFERENTIATION OF TRANSCENDENTAL FUNCTIONS

ART.	PAGE
1. Differentiation of $\sin x$	62
2. Differentiation of $\cos x$, $\tan x$, etc.	67
3. Inverse Functions	68
4. The Inverse Trigonometric Functions	69
5. Logarithms and Exponentials	74
6. Differentiation of $\log x$	78
7. The Compound Interest Law	82
8. Differentiation of e^x , a^x	83

CHAPTER V

INFINITESIMALS AND DIFFERENTIALS

1. Infinitesimals	85
2. Fundamental Theorem	89
3. Tangents in Polar Coordinates	90
4. Differentials	91
5. Technique of Differentiation	94
6. Differential of Arc	99
7. Rates and Velocities	101

CHAPTER VI

INTEGRATION

1. The Area under a Curve	111
2. The Integral	114
3. Special Formulas of Integration	118
4. Integration by Substitution	119
5. Integration by Ingenious Devices	122
6. Integration by Parts	125
7. Use of the Tables	126
8. Length of the Arc of a Curve	129

CHAPTER VII

CURVATURE. EVOLUTES

1. Curvature	134
2. The Osculating Circle	138

CONTENTS

ART.	PAGE
3. The Evolute	139
4. Properties of the Evolute	143

CHAPTER VIII

THE CYCLOID

1. The Equations of the Cycloid	146
2. Properties of the Cycloid	147
3. The Epicycloid and the Hypocycloid	149

CHAPTER IX

DEFINITE INTEGRALS

1. A New Expression for the Area under a Curve	153
2. The Fundamental Theorem of the Integral Calculus	154
3. Volume of a Solid of Revolution	157
4. Other Volumes	159
5. Fluid Pressure	161
6. Duhamel's Theorem	164
7. Length of a Curve	166
8. Area of a Surface of Revolution	167
9. Centre of Gravity	169
10. Centre of Gravity of Solids and Surfaces of Revolution	170
11. Centre of Gravity of Plane Areas	172
12. General Formulation	174
13. Centre of Fluid Pressure	175
14. Moment of Inertia	176
15. A General Theorem	179
16. The Attraction of Gravitation	181
17. Proof of Formula (3). Variable Limits of Integration	184

CHAPTER X

MECHANICS

1. The Laws of Motion	190
2. Absolute Units of Force	194
3. Simple Harmonic Motion	201
4. Motion under the Attraction of Gravitation	206
5. Constrained Motion	209

ART.	PAGE
6. Motion in a Resisting Medium	212
7. Graph of the Resistance	216
8. Motion under an Attractive Force with Damping	218
9. Motion of a Projectile	224

CHAPTER XI

THE LAW OF THE MEAN. INDETERMINATE FORMS

1. Rolle's Theorem	229
2. The Law of the Mean	230
3. Application	231
4. Indeterminate Forms. The Limit $\frac{0}{0}$	231
5. A More General Form of the Law of the Mean	234
6. The Limit $\frac{0}{0}$, Concluded	235
7. The Limit $\frac{\infty}{\infty}$	236
8. The Limit $0 \cdot \infty$	238
9. The Limits 0^0 , 1^∞ , ∞^0 , and $\infty - \infty$	239

CHAPTER XII

CONVERGENCE OF INFINITE SERIES

1. The Geometric Series	243
2. Definition of an Infinite Series	244
3. Tests for Convergence	245
4. Divergent Series	248
5. The Test-Ratio Test	250
6. Alternating Series	252
7. Series of Positive and Negative Terms; General Case	254
8. Power Series	257
9. Operations with Infinite Series	258

CHAPTER XIII

TAYLOR'S THEOREM

1. Maclaurin's Series	262
2. Taylor's Series	264
3. Proof of Taylor's Theorem	266
4. A Second Form for the Remainder	269
5. Development of e^x , $\sin x$, $\cos x$	269

CONTENTS

xiii

ART.	PAGE
6. The Binomial Theorem	272
7. Development of $\sin^{-1} x$	274
8. Development of $\tan x$	274
9. Applications	275

CHAPTER XIV

PARTIAL DIFFERENTIATION

1. Functions of Several Variables. Limits and Continuity	282
2. Formulas of Solid Analytic Geometry	283
3. Partial Derivatives	287
4. Geometric Interpretation	288
5. Derivatives of Higher Order	290
6. The Total Differential	292
7. Continuation. Change of Variable	295
8. Conclusion	298
9. Euler's Theorem for Homogeneous Functions	300
10. Differentiation of Implicit Functions	302
11. A Question of Notation	306
12. Small Errors	306
13. Directional Derivatives	308
14. Exact Differentials	309

CHAPTER XV

APPLICATIONS TO THE GEOMETRY OF SPACE

1. Tangent Plane and Normal Line of a Surface	316
2. Tangent Line and Normal Plane of a Space Curve	317
3. The Osculating Plane	323
4. Confocal Quadrics	326
5. Curves on the Sphere, Cylinder, and Cone	329
6. Mercator's Chart	331

CHAPTER XVI

TAYLOR'S THEOREM FOR FUNCTIONS OF SEVERAL VARIABLES

1. The Law of the Mean	334
2. Taylor's Theorem	335
3. Maxima and Minima	336
4. Test by the Derivatives of the Second Order	340

CHAPTER XVII

ENVELOPES

ART.		PAGE
1.	Envelope of a Family of Curves	344
2.	Envelope of Tangents and Normals	348
3.	Caustics	350

CHAPTER XVIII

DOUBLE INTEGRALS

1.	Volume of Any Solid	351
2.	Two Expressions for the Volume under a Surface ; First Method	353
3.	Continuation ; Second Method	356
4.	The Fundamental Theorem of the Integral Calculus	357
5.	Moments of Inertia	359
6.	Theorems of Pappus	362
7.	Polar Coordinates	363
8.	Areas of Surfaces	367
9.	Cylindrical Surfaces	370
10.	Analytical Proof of the Fundamental Theorem ; Cartesian Co-ordinates	371
11.	Continuation ; Polar Coordinates	373
12.	Surface Integrals	374

CHAPTER XIX

TRIPLE INTEGRALS

1.	Definition of the Triple Integral	380
2.	The Iterated Integral	382
3.	Continuation ; Polar Coordinates	385
4.	Line Integrals	390

CHAPTER XX

APPROXIMATE COMPUTATIONS. HYPERBOLIC FUNCTIONS

1.	The Problem of Numerical Computation	398
2.	Solution of Equations. Known Graphs	398
3.	Newton's Method	399
4.	Direct Use of the Tables	402
5.	Successive Approximations	403

CONTENTS

XV

ART.	PAGE
6. Definite Integrals. Simpson's Rule	406
7. Amsler's Planimeter	409
8. The Hyperbolic Functions	412

APPENDIX

A. THE EXPONENTIAL FUNCTION	417
B. FUNCTIONS WITHOUT DERIVATIVES	422
SUPPLEMENTARY EXERCISES	424
INDEX	460

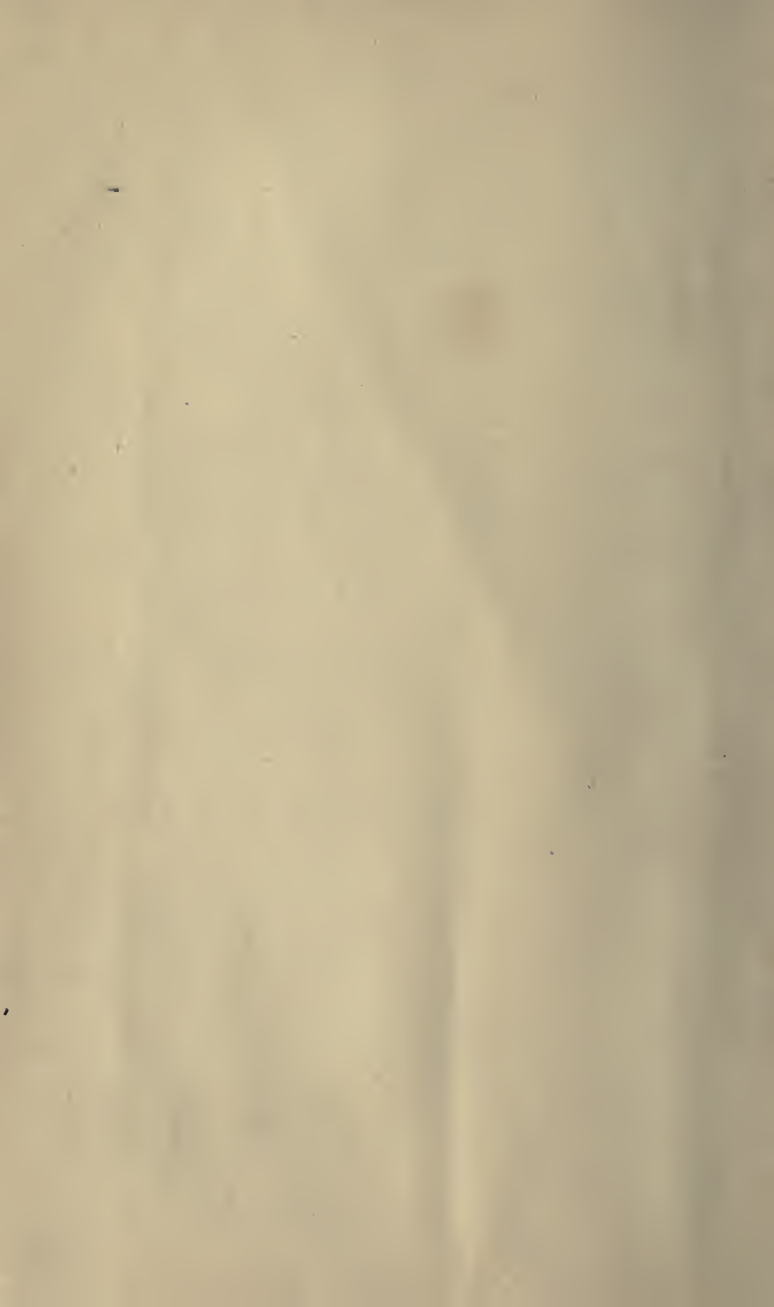

CALCULUS

CHAPTER I

INTRODUCTION

1. Functions. The student has already met the idea of the function in the graphs he has plotted and used in Algebra and Analytic Geometry. For example, if

$$y = 2x + 3,$$

the graph is a straight line; if

$$y^2 = 2mx, \quad y = \pm \sqrt{2mx},$$

it is a parabola, and if

$$y = \sin x,$$

we get a succession of arches that recur periodically. Thus a function was thought of originally as an expression involving x and having a definite value when any special value is given to x :

$$f(x) = 2x + 3,$$

or

$$f(x) = \pm \sqrt{2mx},$$

or

$$f(x) = \sin x.$$

Other letters used to denote a function are $\phi(x)$, $\psi(x)$, $F(x)$, etc. We read $f(x)$ as "f of x."

Further examples of functions are the following: (a) the volume of a sphere, V , as a function of the length of the radius, r :

$$V = \frac{4}{3} \pi r^3;$$

(b) the distance s that a stone falls when dropped from rest, as a function of the time t that it has been falling :

$$s = 16t^2;$$

(c) the sum of the first n terms of a geometric progression :

$$s_n = a + ar + ar^2 + \dots + ar^{n-1},$$

as a function of n :

$$s_n = \frac{a - ar^n}{1 - r}.$$

In higher mathematics the conception of the function is enlarged so as to include not merely the case that y is actually expressed in terms of x by a mathematical formula, but also the case of any law whatever by which, when x is given, y is determined. We will state this conception as a formal definition.

DEFINITION OF A FUNCTION. *y is said to be a function of x if, when x is given, y is determined.*

As an example of this broader notion of the function consider the curve traced out by the pen of a self-registering thermometer. Here, a sheet of paper is wound round a drum which turns slowly and at uniform speed, its axis being vertical. A pen, pressing against this drum, is attached to a thermometer and can move vertically up and down. The height of the pen above the lower edge of the paper depends on the temperature and is proportional to the height of the temperature above a given degree, say the freezing point. Thus if the drum makes one revolution a day, the curve will show the temperature at any time of the day in question. The sheet of paper, unwound and spread out flat, exhibits, then, the temperature y as a function of the time x .*

* Objection has been raised to such illustrations as the above on the ground that the ink mark does not define y accurately for a given x , since the material graph has appreciable breadth. True ; but we may proceed here as in geometry, when we idealize the right line. What we see with our eyes is a taut string or a line drawn with a ruler or a portion of the

Other examples of this broader conception of the function are: the pressure per square inch of a gas enclosed in a vessel, regarded as a function of the temperature; and the resistance of the atmosphere to the motion of a rifle bullet, regarded as a function of the velocity.

A function may involve one or more *constants*, as, for example:

$$f(x) = ax + b, \quad \phi(x) = \tan ax.$$

Here, a and b are any two numbers, which, however, once chosen, are held fast and do not vary with x .

If y is a function of x , $y = f(x)$, then x is called the *independent variable* and y the *dependent variable*. The independent variable is the one which we think of as chosen arbitrarily, *i.e.* we assign to it at pleasure any values which it can take on under the conditions of the problem. The other variable or variables are then determined. Thus when we write:

$$s = 16t^2,$$

we think of t as the independent, s as the dependent variable. But if we solve for t and write:

$$t = \frac{\sqrt{s}}{4},$$

then we think of s , which is here necessarily restricted to positive values, as the independent, t as the dependent variable. In general, if two variables are connected by a single equation, as for example

$$pv = C,$$

where C is a constant, either may be chosen as the independent variable, the other thus becoming the function.

path of a stone thrown hard. These are not straight lines; but they suggest a concept obtained by thinking of finer and ever finer threads and narrower and ever narrower lines, and thus we get at the straight lines of geometry. So here, we may think of the actual temperature at each instant as having a single definite value and thus being a function of the time, the ideal graph of this function, then, being a geometric curve that lies within the material belt of ink traced out by the pen.

A function may depend on more than one independent variable. Thus the area of a rectangle is equal to the product of two adjacent sides. Further examples:

$$f(x, y) = \frac{1}{2} \log(x^2 + y^2),$$

$$\phi(x, y, z) = ax^2 + by^2 + cz^2 - d.$$

Again, it may happen that to one value of x correspond several values of y , as when

$$x^2 + y^2 = a^2, \quad y = \pm \sqrt{a^2 - x^2}.$$

y is then said to be a *multiple-valued function* of x . But usually, when this is the case, it is natural to group the values so as to form a number of single-valued functions. In the above example these will be*

$$y = \sqrt{a^2 - x^2} \quad \text{and} \quad y = -\sqrt{a^2 - x^2}.$$

In this book a function will be understood to be single-valued unless the contrary is explicitly stated.

A function is said to be *continuous* if a small change in the variable gives rise to a small change in the function. Thus the function

$$y = \frac{1}{x},$$

whose graph is a hyperbola, is in general continuous; but when x approaches 0, y increases numerically without limit, and so at the point $x = 0$ the function is discontinuous.

* The sign $\sqrt{\quad}$ means the *positive* square root of the radicand, *not*, either the positive *or* the negative square root at pleasure. Thus, $\sqrt{4}$ is 2, and not -2 . This does not mean that 4 has only one square root. It means that the *notation* $\sqrt{4}$ calls for the positive, and not for the negative, of these two roots. Again,

$$\sqrt{x^2} = x, \quad \text{if } x \text{ is positive;}$$

$$\sqrt{x^2} = -x, \quad \text{if } x \text{ is negative.}$$

A similar remark applies to the symbol $\sqrt[n]{\quad}$, which likewise is used to mean the positive n th root.

It is frequently desirable to use merely the *numerical* or *absolute value* of a quantity, and to have a notation for the same. The notation is: $|x|$, read "the absolute value of x ." Thus, $|-3| = 3$; $|3| = 3$. Again, whether a be positive or negative, we always have

$$\sqrt{a^2} = |a|.$$

2. Slope of a Curve. We have learned in Analytic Geometry how to find the slope of some of the simpler curves. The method is of fundamental importance in the Calculus, and so we begin by recalling it.

Consider, for example, the parabola :

$$(1) \quad y = x^2.$$

Let P , with the coordinates (x_0, y_0) , be an arbitrary point on this curve, and let P' : (x', y') , be a second point. Pass a secant through P and P' . Let

$$x' = x_0 + h, \quad y' = y_0 + k.$$

Then the slope of the secant will be :

$$\tan \tau' = \frac{y' - y_0}{x' - x_0} = \frac{k}{h}.$$

When P' approaches P as its limit, the secant rotates about P and approaches the tangent as its limit, its slope approaching the slope of the tangent : *

$$\lim_{P' \doteq P} \tan \tau' = \tan \tau.$$

We wish to evaluate this limit.

* The sign \doteq means that P' approaches P as its limit, without, however, ever being allowed to reach this limit. For, if P' were to coincide with P , we should no longer have a determinate secant, one point not being sufficient to determine a straight line.

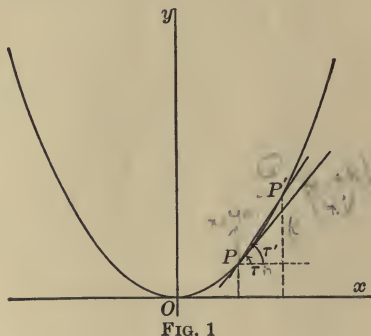

FIG. 1

Suppose the point P is the point $(1, 1)$. Let us compute k and $\tan \tau' = k/h$ for a few values of h . Here, $x_0 = 1, y_0 = 1$. If $h = .1$,

$$\text{then } x' = x_0 + h = 1.1, \quad y' = y_0 + k = 1.21$$

$$\text{and } k = y' - y_0 = .21;$$

$$\text{hence } \tan \tau' = \frac{k}{h} = 2.1.$$

The following table shows further sets of values of h, k , and $\tan \tau'$ that belong together:

h	k	$\tan \tau' = \frac{k}{h}$
.1	.21	2.1
.01	.0201	2.01
.001	.002001	2.001

It is the last column that we are chiefly interested in, and its numbers appear to be approaching nearer and nearer to 2 as their limit. Let us prove that this is really so. As the proof is just as simple for an arbitrary point P , we will return to the general case.

Since P and P' lie on the curve (1), we have:

$$(2) \quad y_0 = x_0^2,$$

$$(3) \quad y_0 + k = (x_0 + h)^2 = x_0^2 + 2x_0h + h^2.$$

Hence, subtracting (2) from (3), we get:

$$(4) \quad k = 2x_0h + h^2,$$

$$\text{and finally: } \tan \tau' = \frac{k}{h} = 2x_0 + h.$$

Now let P' approach P as its limit. Then h approaches 0 and we have:

$$\lim_{P' \rightarrow P} \tan \tau' = \lim_{h \rightarrow 0} \frac{k}{h} = \lim_{h \rightarrow 0} (2x_0 + h),$$

$$(5) \quad \tan \tau = 2x_0.$$

If, in particular, $x_0 = 1$, then $\tan \tau = 2$, as we set out to prove.

EXERCISES

1. If $f(x) = x^3 - 3x + 2$,
show that $f(1) = 0$, and compute $f(0)$, $f(-1)$, $f(1\frac{1}{3})$.

2. If $f(x) = \frac{2x-3}{x+7}$,
find $f(\sqrt{2})$ correct to three significant figures. *Ans.* — .0204.

3. If $F(x) = (x - x^3) \sin x$,
find all the values of x for which $F(x) = 0$.

4. If $\phi(x) = 2^x$,
find $\phi(0)$, $\phi(-3)$, $\phi(\frac{1}{3})$.

5. If $f(x) = x - \sqrt{a^2 - x^2}$,
find $f(a)$ and $f(0)$.

6. If in the preceding question $a = \cos \frac{5\pi}{6}$, compute $f(0)$ to three significant figures.

7. If $\psi(x) = x^{\frac{2}{3}} - x^{-\frac{2}{3}}$,
find $\psi(8)$.

8. If $f(x) = x \log_{10}(12 - x^2)$,
find $f(-2)$ and $f(3\frac{1}{3})$.

9. Solve the equation

$$x^3 - xy + 3 = 5y$$

for y , thus expressing y as a function of x .

10. If $f(x) = a^x$,
show that $f(x)f(y) = f(x+y)$.

11. Continue the table of § 2 two lines further, using the values $h = .0001$ and $h = .00001$.

12. Find the slope of the curve

$$8y = 3x^3$$

at the point $(2, 3)$, first preparing a table similar to that of § 2 and then proving that the apparent limit is actually the limit.

13. Find the slope of the curve

$$y = x^3 - x^2$$

at any point (x_0, y_0) .

14. Find the slope of the curve

$$y = ax^2 + bx + c$$

at the point (x_0, y_0) .

15. Find the slope of the curve

$$y = \frac{1}{x}$$

at (x_0, y_0) .

$$\frac{12}{1-d}$$

$$\frac{8}{1-d}$$

CHAPTER II

DIFFERENTIATION OF ALGEBRAIC FUNCTIONS GENERAL THEOREMS

1. **Definition of the Derivative.** The Calculus deals with varying quantity. If y is a function of x , then x is thought of, not as having one or another special value, but as flowing or growing, just as we think of time or of the expanding circular ripples made by a stone dropped into a placid pond. And y varies with x , sometimes increasing, sometimes decreasing. Now if we consider the change in x for a short interval, say from $x = x_0$ to $x = x'$, the corresponding change in y , as y goes from y_0 to y' , will be in general almost proportional to the change in x , as we see by looking at the graph of the function; for

$$\frac{y' - y_0}{x' - x_0} = \tan \tau',$$

and $\tan \tau'$ approaches the limit $\tan \tau$, *i.e.* comes nearer and nearer to the fixed value $\tan \tau$, the slope of the tangent.

The determination of this limit:

$$\lim_{x' \rightarrow x_0} \frac{y' - y_0}{x' - x_0} = \tan \tau,$$

is a problem of first importance, and we shall devote the next few chapters to solving it for the functions we are already familiar with and to giving various applications of the results.

We will first formulate the idea we have just explained as a definition. Let

$$(1) \quad y = f(x)$$

be a given function of x . Form the function for an arbitrary value x_0 of x :

$$(2) \quad y_0 = f(x_0),$$

and then give to x_0 an *increment*, Δx ; *i.e.* consider a second value x' of x and denote the difference $x' - x_0$ by the symbol * Δx :

$$x' - x_0 = \Delta x; \quad x' = x_0 + \Delta x.$$

The function y will thereby have changed from the value y_0 to the value

$$(3) \quad y' = f(x')$$

and hence have received an increment

$$y' - y_0 = \Delta y; \quad y' = y_0 + \Delta y.$$

From (3), written in the form:

$$(4) \quad y_0 + \Delta y = f(x_0 + \Delta x),$$

and (2), we obtain by subtraction:

$$\Delta y = f(x_0 + \Delta x) - f(x_0),$$

and hence

$$(5) \quad \frac{\Delta y}{\Delta x} = \frac{f(x_0 + \Delta x) - f(x_0)}{\Delta x}.$$

DEFINITION OF A DERIVATIVE. *The limit which the ratio (5) approaches when Δx approaches 0:*

* The student must not think of this symbol as meaning Δ times x . We might have used a single letter, as h , to represent the difference in question: $x' = x_0 + h$; but h would not have reminded us that it is the increment of x , and not of y , with which we are concerned. The notation is read "*delta x*."

$$(6) \quad \lim_{\Delta x \neq 0} \frac{\Delta y}{\Delta x} \quad \text{or} \quad \lim_{\Delta x \neq 0} \frac{f(x_0 + \Delta x) - f(x_0)}{\Delta x},$$

is called the derivative of y with respect to x and is denoted by $D_x y$, (read: “ $D x$ of y ”):

$$(7) \quad \lim_{\Delta x \neq 0} \frac{\Delta y}{\Delta x} = D_x y.$$

In the above definition Δx may be negative as well as positive and the limit (6) must have the same value when Δx approaches 0 from the negative side as when it approaches 0 from the positive side.

Our problem is, then, to compute the derivative for the various functions that present themselves.

To differentiate a function is to find its derivative.

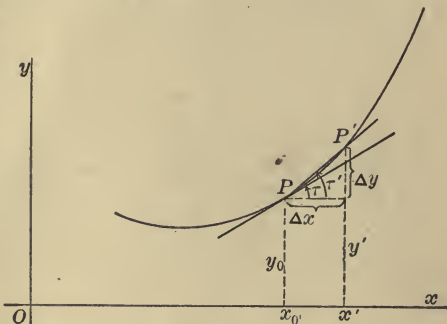

FIG. 2

The geometrical interpretation of the analytical process of differentiation is to find the slope of the graph of the function.

2. Differentiation of x^n . Let

$$(8) \quad y = x^n,$$

where n is a positive integer. To differentiate y we are first to give x an arbitrary value x_0 and compute the corresponding value y_0 of the function:

$$(9) \quad y_0 = x_0^n.$$

Next, give to x an increment, Δx , whereby y receives a corresponding increment, Δy :

$$(10) \quad y_0 + \Delta y = (x_0 + \Delta x)^n.$$

Expanding the right-hand member by the Binomial Theorem, we get:

$$(11) \quad y_0 + \Delta y = x_0^n + nx_0^{n-1}\Delta x + \frac{n(n-1)}{1 \cdot 2}x_0^{n-2}\Delta x^2 + \dots + \Delta x^n.$$

If we subtract (9) from (11) and divide through by Δx , we get:

$$\frac{\Delta y}{\Delta x} = nx_0^{n-1} + \frac{n(n-1)}{1 \cdot 2}x_0^{n-2}\Delta x + \dots + \Delta x^{n-1}.$$

We are now ready to allow Δx to approach 0 as its limit. On the right-hand side the first term is constant. Each of the succeeding terms approaches 0 as its limit, and so their sum approaches 0. Hence we have:

$$\lim_{\Delta x \rightarrow 0} \frac{\Delta y}{\Delta x} = nx_0^{n-1}.$$

The subscript of the x_0 has now served its purpose of reminding us that x_0 is not to vary with Δx . In the final result we may drop the subscript, for x_0 is *any* value of x , and thus we obtain the formula, or theorem:

$$(12) \quad D_x x^n = nx^{n-1}.$$

In particular, if $n = 1$, we have

$$(13) \quad D_x x = 1.$$

EXERCISES

1. Show that

$$D_x(cx^n) = ncx^{n-1},$$

where c is a constant.

2. Write down the derivatives of the following functions:

$$x^2, \quad x^3, \quad x^{49}, \quad 7x, \quad -9x^4.$$

3. Differentiate the function:

$$y = \frac{1}{x^2}. \quad \text{Ans.} \quad -\frac{2}{x^3}.$$

4. Differentiate: $u = t^2 - t.$

3. Derivative of a Constant. If the function $f(x)$ is a constant:

$$y = f(x) = c,$$

the graph is a straight line parallel to the axis of x , and so the slope is 0. Hence

$$(14) \quad D_x c = 0.$$

It is instructive to obtain this result analytically from the definition of § 1. We have:

$$y_0 = f(x_0) = c,$$

$$y_0 + \Delta y = f(x_0 + \Delta x) = c,$$

hence $\Delta y = 0$ and $\frac{\Delta y}{\Delta x} = 0.$

Allowing Δx now to approach 0 as its limit, we see that the value of the variable, $\Delta y/\Delta x$, is always 0, and hence its limit is 0:

$$\lim_{\Delta x \rightarrow 0} \frac{\Delta y}{\Delta x} = 0 \quad \text{or} \quad D_x c = 0.$$

4. General Formulas of Differentiation.

THEOREM I. *The derivative of the product of a constant and a function is equal to the product of the constant into the derivative of the function:*

$$(I) \quad D_x(cu) = cD_x u.$$

For, let $y = cu.$

Then $y_0 = cu_0,$

$$y_0 + \Delta y = c(u_0 + \Delta u),$$

hence $\Delta y = c\Delta u,$

$$\frac{\Delta y}{\Delta x} = c \frac{\Delta u}{\Delta x},$$

and $\lim_{\Delta x \rightarrow 0} \frac{\Delta y}{\Delta x} = \lim_{\Delta x \rightarrow 0} \left(c \frac{\Delta u}{\Delta x} \right).$

The limit of the left-hand side is $D_x y$. On the right, $\Delta u / \Delta x$ approaches $D_x u$ as its limit, hence the limit of the right-hand side is * $cD_x u$, and we have

$$D_x(cu) = cD_x u, \quad \text{q. e. d.}$$

THEOREM II. *The derivative of the sum of two functions is equal to the sum of their derivatives:*

$$(II) \quad D_x(u + v) = D_x u + D_x v.$$

For, let $y = u + v$.

Then $y_0 = u_0 + v_0$,

$$y_0 + \Delta y = u_0 + \Delta u + v_0 + \Delta v,$$

hence $\Delta y = \Delta u + \Delta v$,

and $\frac{\Delta y}{\Delta x} = \frac{\Delta u}{\Delta x} + \frac{\Delta v}{\Delta x}$.

When Δx approaches 0, the first term on the right approaches $D_x u$ and the second $D_x v$. Hence the whole right-hand side approaches * $D_x u + D_x v$, and we have

$$\lim_{\Delta x \neq 0} \frac{\Delta y}{\Delta x} = \lim_{\Delta x \neq 0} \left(\frac{\Delta u}{\Delta x} + \frac{\Delta v}{\Delta x} \right) = \lim_{\Delta x \neq 0} \frac{\Delta u}{\Delta x} + \lim_{\Delta x \neq 0} \frac{\Delta v}{\Delta x},$$

or $D_x y = D_x u + D_x v, \quad \text{q. e. d.}$

COROLLARY. *The derivative of the sum of any number of functions is equal to the sum of their derivatives.*

If we have the sum of three functions, we can write

$$u + v + w = u + (v + w).$$

Hence $D_x(u + v + w) = D_x u + D_x(v + w)$
 $= D_x u + D_x v + D_x w.$

* For a careful proof of this point cf. § 5.

Next, we can consider the sum of four functions, and so on. Or we can extend the proof of Theorem II immediately to the sum of n functions.

Polynomials. We are now in a position to differentiate any polynomial. For example:

$$\begin{aligned} & D_x(7x^4 - 5x^3 + x + 2) \\ &= D_x(7x^4) + D_x(-5x^3) + D_x x + D_x 2 \\ &= 7 D_x x^4 - 5 D_x x^3 + 1 = 28x^3 - 15x^2 + 1. \end{aligned}$$

EXERCISES

Differentiate the following functions:

1. $5x^5 - 8x^4 + 7x^3 - x + 1.$ 3. $\pi x^3 - 4\frac{3}{4}x^2 - \sqrt{2}.$

2. $\frac{8x^7 - 6x + 5}{9}.$ 4. $\frac{ax^2 + 2hx + b}{2c}.$

5. Differentiate

(a) $v_0 t - 16t^2$ with respect to t .

(b) $a + bs + cs^2$ with respect to s .

(c) $.01ly^4 - 8.15my^2 - .9lm$ with respect to y .

6. Find the slope of the curve

$$4y = x^4 - 8x - 1$$

at the point $(1, -2)$.

7. At what angles do the curves $y = x^2$ and $y = x^3$ intersect?

Ans. 0° and $8^\circ 7'$.

5. Three Theorems about Limits.

THEOREM A. *The limit of the sum of two variables is equal to the sum of their limits:*

$$\lim (X + Y) = \lim X + \lim Y.$$

Let $\lim X = A, \quad \lim Y = B,$

and let ϵ denote the difference between X and its limit, A :

$$X - A = \epsilon, \quad X = A + \epsilon.$$

Then $\lim \epsilon = 0.$

(If X is less than A , ϵ will be a negative quantity.)

In like manner let

$$Y - B = \eta, \quad Y = B + \eta.$$

Then $\lim \eta = 0.$

Writing now

$$X + Y = A + B + \epsilon + \eta,$$

we see that the limit of the right-hand side is $A + B$. Hence

$$\lim (X + Y) = A + B, \quad \text{q. e. d.}$$

COROLLARY. *The limit of the sum of n variables is equal to the sum of the limits of these variables, n being any fixed number:*

$$\lim (X_1 + X_2 + \cdots + X_n) = \lim X_1 + \lim X_2 + \cdots + \lim X_n.$$

THEOREM B. *The limit of a product is equal to the product of the limits:*

$$\lim (XY) = (\lim X)(\lim Y).$$

Here

$$\begin{aligned} XY &= (A + \epsilon)(B + \eta) \\ &= AB + A\eta + B\epsilon + \epsilon\eta. \end{aligned}$$

By Theorem A, Corollary, the limit of the right-hand side is

$$AB + \lim (A\eta) + \lim (B\epsilon) + \lim (\epsilon\eta).$$

The last limit is obviously 0. As regards the first two, it is easy to see that if a variable (as η) approaches 0, then the product of any constant (as A) times this variable must also approach 0. An unfavorable case would be that in which the constant is very large, say 10,000,000. But even then the variable, as it decreases, will finally become and remain numerically less than $10^{-7} = \frac{1}{10,000,000}$, and so the product becomes

less than 1. As the variable decreases still further, it becomes and remains numerically less than 10^{-8} , then less than 10^{-9} , and so on; the product thus becoming and remaining numerically less than $\frac{1}{10^8}$, $\frac{1}{10^9}$, and so on. Hence the limit of the product is 0.

Thus each of the limits in the above expression is seen to be 0, and hence

$$\lim (XY) = AB, \quad \text{q. e. d.}$$

In particular, we see that *the limit of a constant times a variable is equal to the product of the constant into the limit of the variable* :

$$\lim (CX) = C \lim (X).$$

For, a constant is a special case of a variable.

COROLLARY. *The limit of the product of n variables is equal to the product of their limits, n being any fixed number :*

$$\lim (X_1 X_2 \dots X_n) = (\lim X_1)(\lim X_2) \dots (\lim X_n).$$

THEOREM C. *The limit of the quotient of two variables is equal to the quotient of their limits, provided that the limit of the variable that forms the denominator is not 0 :*

$$\lim \frac{X}{Y} = \frac{\lim X}{\lim Y} \quad \text{if} \quad \lim Y \neq 0.$$

For

$$\frac{X}{Y} - \frac{A}{B} = \frac{A + \epsilon}{B + \eta} - \frac{A}{B} = \frac{B\epsilon - A\eta}{B(B + \eta)},$$

,

$$\frac{X}{Y} = \frac{A}{B} + \frac{B\epsilon - A\eta}{B^2} \frac{1}{1 + \frac{\eta}{B}}.$$

The limit of the first fraction in the last term is 0, by Theorems A and B. The second fraction ultimately becomes positive and remains less than 2, even if η is negative. For, since $\lim \eta = 0$, $1/B$ will finally become and remain algebraically greater than $-\frac{1}{2}$:

$$-\frac{1}{2} < \frac{\eta}{B}, \quad \frac{1}{2} < 1 + \frac{\eta}{B}, \quad \frac{1}{1 + \frac{\eta}{B}} < 2.$$

Hence the last term becomes and remains numerically less than twice the first factor, and consequently its limit is 0.

$$\therefore \lim \frac{X}{Y} = \frac{A}{B}, \quad \text{q. e. d.}$$

In particular, we see that, *if a variable approaches unity as its limit, its reciprocal also approaches unity* :

$$\text{If } \lim X = 1, \quad \text{then} \quad \lim \frac{1}{X} = 1.$$

Remark. If the denominator Y approaches 0 as its limit, no general inference about the limit of the fraction can be drawn, as the following examples show. Let Y have the values :

$$Y = \frac{1}{10}, \frac{1}{100}, \frac{1}{1000}, \dots, \frac{1}{10^n}, \dots$$

(1) If the corresponding values of X are :

$$X = \frac{1}{10^2}, \frac{1}{100^2}, \frac{1}{1000^2}, \dots, \frac{1}{10^{2n}}, \dots,$$

$$\text{then} \quad \lim \frac{X}{Y} = \lim \frac{1}{10^n} = 0.$$

$$(2) \quad \text{If} \quad X = \frac{1}{\sqrt{10}}, \frac{1}{\sqrt{100}}, \frac{1}{\sqrt{1000}}, \dots, \frac{1}{10^{\frac{n}{2}}}, \dots,$$

then $X/Y = 10^{n/2}$ approaches no limit, but increases beyond all limit.

$$(3) \quad \text{If} \quad X = \frac{c}{10}, \frac{c}{100}, \frac{c}{1000}, \dots, \frac{c}{10^n}, \dots$$

where c is any arbitrarily chosen fixed number, then

$$\lim \frac{X}{Y} = c.$$

$$(4) \text{ If } X = \frac{1}{10}, -\frac{1}{100}, \frac{1}{1000}, -\frac{1}{10,000}, \dots,$$

then X/Y assumes alternately the values $+1$ and -1 , and hence, although remaining finite, approaches no limit.

To sum up, then, we see that when X and Y both approach 0 as their limit, their ratio may approach any limit whatever, or it may increase beyond all limit, or finally, although *remaining finite, i. e.* always lying between two *fixed* numbers, no matter how widely the latter may differ from each other in value, — it may jump about and so fail to approach a limit.

Infinity. If $\lim X = A \neq 0$ and $\lim Y = 0$, then X/Y increases beyond all limit, or *becomes infinite*. A variable Z is said to become infinite when it ultimately becomes and remains greater numerically than any preassigned quantity, however large. If it takes on only positive values, it *becomes positively infinite*; if only negative values, it *becomes negatively infinite*. We express its behavior by the notation:

$$\lim Z = \infty \quad \text{or} \quad \lim Z = +\infty \quad \text{or} \quad \lim Z = -\infty.$$

But this notation does not imply that infinity is a limit; the variable in this case approaches no limit. And so the notation should not be read “ Z approaches infinity” or “ Z equals infinity;” but “ Z becomes infinite.”

Thus if the graph of a function has its tangent at a certain point parallel to the axis of ordinates, we shall have for that point:

$$\lim_{\Delta x \neq 0} \frac{\Delta y}{\Delta x} = \infty;$$

read: “ $\Delta y/\Delta x$ becomes infinite when Δx approaches 0.”

Some writers find it convenient to use the expression “a variable approaches a limit” to include the case that the variable becomes infinite. We shall not adopt this mode of expression, but shall understand the words “approaches a limit” in their strict sense.

If a function $f(x)$ becomes infinite when x approaches a certain value a , as for example

$$f(x) = \frac{1}{x} \quad \text{for } a = 0,$$

we denote this by writing

$$f(a) = \infty$$

(or $f(a) = +\infty$ or $-\infty$, if this happens to be the case and we wish to call attention to the fact).

Definition of a Continuous Function. We can now make more explicit the definition given in Chapter I by saying: $f(x)$ is continuous at the point $x = a$ if

$$\lim_{x \rightarrow a} f(x) = f(a).$$

From Exercises 1–3 below it follows that the polynomials are continuous for all values of x , and that the fractional rational functions are continuous except when the denominator vanishes.

EXERCISES

1. Show that, if n is any positive integer,

$$\lim (X^n) = (\lim X)^n.$$

2. If $G(x) = c_0 + c_1x + c_2x^2 + \cdots + c_nx^n$,

then $\lim_{x \rightarrow a} G(x) = G(a) = c_0 + c_1a + c_2a^2 + \cdots + c_na^n$:

3. If $G(x)$ and $F(x)$ are any two polynomials and if $F(a) \neq 0$,

then

$$\lim_{x \rightarrow a} \frac{G(x)}{F(x)} = \frac{G(a)}{F(a)}.$$

4. If X remains finite and Y approaches 0 as its limit, show that

$$\lim (XY) = 0.$$

5. Show that

$$\lim_{x \rightarrow \infty} \frac{x^2 + 1}{3x^2 + 2x - 1} = \frac{1}{3}.$$

Suggestion: Begin by dividing the numerator and the denominator by x^2 .

6. Evaluate the following limits:

$$(a) \lim_{x \rightarrow \infty} \frac{x+1}{x^3-7x+3}; \quad (d) \lim_{x \neq 0} \frac{ax+bx^{-1}}{cx+dx^{-1}};$$

$$(b) \lim_{x \rightarrow \infty} \frac{12x^6+5}{4x^6+3x^4+7x^2-1}; \quad (e) \lim_{x \rightarrow \infty} \frac{\sqrt{1+x^2}}{x};$$

$$(c) \lim_{x \rightarrow \infty} \frac{ax+bx^{-1}}{cx+dx^{-1}}; \quad (f) \lim_{x \rightarrow \infty} \frac{x}{\sqrt{1+x^4}}.$$

6. General Formulas of Differentiation, Concluded.

THEOREM III. *The derivative of a product is given by the formula:*

$$(III) \quad D_x(uv) = uD_x v + vD_x u.$$

Let $y = uv$.

Then $y_0 = u_0 v_0$,

$$y_0 + \Delta y = (u_0 + \Delta u)(v_0 + \Delta v),$$

$$\Delta y = u_0 \Delta v + v_0 \Delta u + \Delta u \Delta v,$$

$$\frac{\Delta y}{\Delta x} = u_0 \frac{\Delta v}{\Delta x} + v_0 \frac{\Delta u}{\Delta x} + \Delta u \frac{\Delta v}{\Delta x},$$

and, by Theorem A, § 5:

$$\lim_{\Delta x \neq 0} \frac{\Delta y}{\Delta x} = \lim_{\Delta x \neq 0} \left(u_0 \frac{\Delta v}{\Delta x} \right) + \lim_{\Delta x \neq 0} \left(v_0 \frac{\Delta u}{\Delta x} \right) + \lim_{\Delta x \neq 0} \left(\Delta u \frac{\Delta v}{\Delta x} \right).$$

By Theorem B, § 5, the last limit has the value 0, since $\lim \Delta u = 0$ and $\lim (\Delta v / \Delta x) = D_x v$. The first two limits have the values $u_0 D_x v$ and $v_0 D_x u$ respectively.* Hence, dropping the subscripts, we have:

$$D_x y = u D_x v + v D_x u, \quad \text{q. e. d.}$$

* More strictly, the notation should read here, before the subscripts are dropped: $[D_x v]_{x=x_0}$, etc. Similarly in the proofs of Theorems I, II, and V.

By a repeated application of this theorem the product of any number of functions can be differentiated. When more than two factors are present, the formula is conveniently written in the form:

$$(15) \quad \frac{D_x(uvw)}{uvw} = \frac{D_x u}{u} + \frac{D_x v}{v} + \frac{D_x w}{w}$$

For a reason that will appear later, this is called the *logarithmic derivative* of uvw .

THEOREM IV. *The derivative of a quotient is given by the formula:**

$$(IV) \quad D_x\left(\frac{u}{v}\right) = \frac{vD_x u - uD_x v}{v^2}.$$

Let $y = \frac{u}{v}.$

Then $y_0 = \frac{u_0}{v_0}, \quad y_0 + \Delta y = \frac{u_0 + \Delta u}{v_0 + \Delta v},$

$$\Delta y = \frac{u_0 + \Delta u}{v_0 + \Delta v} - \frac{u_0}{v_0} = \frac{v_0 \Delta u - u_0 \Delta v}{v_0(v_0 + \Delta v)},$$

$$\frac{\Delta y}{\Delta x} = \frac{v_0 \frac{\Delta u}{\Delta x} - u_0 \frac{\Delta v}{\Delta x}}{v_0(v_0 + \Delta v)}.$$

By Theorem C of § 5 we have:

$$\lim_{\Delta x \neq 0} \frac{\Delta y}{\Delta x} = \frac{\lim_{\Delta x \neq 0} \left(v_0 \frac{\Delta u}{\Delta x} - u_0 \frac{\Delta v}{\Delta x} \right)}{\lim_{\Delta x \neq 0} [v_0(v_0 + \Delta v)]}.$$

Applying Theorems A and B of § 5 and dropping the subscripts we obtain:

$$D_x y = \frac{vD_x u - uD_x v}{v^2}, \quad \text{q. e. d.}$$

* The student may find it convenient to remember this formula by putting it into words: "The denominator into the derivative of the numerator, minus the numerator into the derivative of the denominator, over the square of the denominator."

Example. Let

$$y = \frac{ax + b}{cx + d}.$$

Then
$$D_x y = \frac{(cx + d)a - (ax + b)c}{(cx + d)^2} = \frac{ad - bc}{(cx + d)^2}.$$

THEOREM V. *If u is expressed as a function of y and y in turn as a function of x :*

$$u = f(y), \quad y = \phi(x),$$

then

$$(V) \quad D_x f(y) = D_y f(y) D_x y$$

or

$$(V') \quad D_x u = D_y u \cdot D_x y.$$

Here $y_0 = \phi(x_0), \quad u_0 = f(y_0),$

$$y_0 + \Delta y = \phi(x_0 + \Delta x), \quad u_0 + \Delta u = f(y_0 + \Delta y),$$

$$\Delta u = f(y_0 + \Delta y) - f(y_0),$$

$$\frac{\Delta u}{\Delta x} = \frac{f(y_0 + \Delta y) - f(y_0)}{\Delta y} \cdot \frac{\Delta y}{\Delta x}.$$

When Δx approaches 0, Δy also approaches 0, and hence the limit of the right-hand side is

$$\left(\lim_{\Delta x \rightarrow 0} \frac{f(y_0 + \Delta y) - f(y_0)}{\Delta y} \right) \left(\lim_{\Delta x \rightarrow 0} \frac{\Delta y}{\Delta x} \right) = D_y f(y) D_x y.$$

The limit of the left-hand side is $D_x u$, and hence

$$D_x u = D_y u \cdot D_x y, \quad \text{q. e. d.}$$

The truth of the theorem does not depend on the particular letters by which the variables are denoted. We may replace, for example, x by t and y by x . Dividing through by the second factor on the right, we thus obtain the formula:

$$(V'') \quad D_x u = \frac{D_t u}{D_t x}.$$

Example. Let $u = (ax + b)^n$,

where n is a positive integer.

Set $y = ax + b$. Then $u = f(y) = y^n$

and $D_x u = D_x y^n = D_y y^n \cdot D_x y = n y^{n-1} \cdot a = na(ax + b)^{n-1}$.

EXERCISES

Differentiate the following functions:

1. $y = \frac{x}{1 - x^2}$.

Ans. $D_x y = \frac{1 + x^2}{(1 - x^2)^2}$.

2. $y = \frac{1}{1 + x^2}$.

4. $y = \frac{x^3}{1 - x}$.

3. $s = \frac{1 - t}{1 + t}$.

5. $y = \frac{x^2}{(1 - x)^2}$.

6. $y = x(a + bx)^n$. *Ans.* $D_x y = [a + (n + 1)bx](a + bx)^{n-1}$.

7. $y = \frac{1}{x^m}$, where m is a positive integer.

8. $y = \frac{1 + x + x^2}{x}$.

9. $y = \frac{5 - x^3 + 5x^6}{x^3}$.

10. Show that Formula (12) holds when n is a negative integer.

Differentiate further:

11. $(t + 3)(2 - t)$.

15. $\frac{z^2 + a^2}{z + a}$.

12. $(a - x)^3$.

16. $(a + bx + cx^2)^n$.

13. $y = \frac{1 - 3x - x^3}{9}$.

17. $\frac{1}{(1 - x^2)^3}$.

14. $\frac{s}{(2s + 3)^2}$.

18. $x = \frac{3y - 1}{y}$.

19. Find the slope of the curve $y = \frac{1}{x}$ at the point $(1, 1)$.

20. Find the slope of the curve

$$240y = (1-x)(2-x)(3-x)(4-x)$$

at the point $x = 0, y = \frac{1}{10}$.

Ans. $-\frac{5}{24}$.

7. **Differentiation of Radicals.** Let us differentiate

$$y = \sqrt{x}.$$

Here, $y_0 = \sqrt{x_0}, \quad y_0 + \Delta y = \sqrt{x_0 + \Delta x}$

$$\frac{\Delta y}{\Delta x} = \frac{\sqrt{x_0 + \Delta x} - \sqrt{x_0}}{\Delta x}.$$

We cannot as yet see what limit the right-hand side approaches when Δx approaches 0, for both numerator and denominator approach 0, and $\frac{0}{0}$ has no meaning, cf. § 5. We can, however, transform the fraction by multiplying numerator and denominator by the *sum* of the radicals and recalling the formula of Elementary Algebra:

$$a^2 - b^2 = (a - b)(a + b).$$

$$\begin{aligned} \text{Thus } \frac{\Delta y}{\Delta x} &= \frac{\sqrt{x_0 + \Delta x} - \sqrt{x_0}}{\Delta x} \cdot \frac{\sqrt{x_0 + \Delta x} + \sqrt{x_0}}{\sqrt{x_0 + \Delta x} + \sqrt{x_0}} \\ &= \frac{1}{\Delta x} \cdot \frac{(x_0 + \Delta x) - x_0}{\sqrt{x_0 + \Delta x} + \sqrt{x_0}} = \frac{1}{\sqrt{x_0 + \Delta x} + \sqrt{x_0}}, \end{aligned}$$

$$\text{and hence } \lim_{\Delta x \neq 0} \frac{\Delta y}{\Delta x} = \lim_{\Delta x \neq 0} \frac{1}{\sqrt{x_0 + \Delta x} + \sqrt{x_0}} = \frac{1}{2\sqrt{x_0}}.$$

Dropping the subscript, we have:

$$(16) \quad D_x \sqrt{x} = \frac{1}{2\sqrt{x}}.$$

We can now differentiate a variety of functions.

Example. To differentiate

$$y = \sqrt{a^2 - x^2}.$$

Introduce a new variable

$$z = a^2 - x^2$$

and then apply Theorem V:*

$$y = \sqrt{z},$$

$$D_x y = D_x \sqrt{z} = D_z \sqrt{z} \cdot D_x z = \frac{1}{2\sqrt{z}} \cdot (-2x) = \frac{-x}{\sqrt{a^2 - x^2}}.$$

Hence

$$D_x \sqrt{a^2 - x^2} = \frac{-x}{\sqrt{a^2 - x^2}}.$$

EXERCISES

Differentiate the following functions:

1. $y = \sqrt{a^2 + x^2}.$

6. $y = \frac{1}{\sqrt{x}}.$ *Ans.* $-\frac{1}{2x^{\frac{3}{2}}}.$

2. $u = \sqrt{a+x} + \sqrt{a-x}.$

7. $\frac{1}{\sqrt{a^2 - x^2}}.$

3. $y = x\sqrt{1-x}.$

8. $y = \sqrt{2mx}.$

4. $u = x^3\sqrt{a^2 + x^2}.$

9. $\frac{x+1}{\sqrt{x}}.$

5. $\frac{t}{\sqrt{1-t^2}}.$ *Ans.* $\frac{1}{(\sqrt{1-t^2})^3}.$

10. $\sqrt{\frac{1-x}{1+x}}.$

* The student should observe that Theorem V is not dependent on the special *letters* used to designate the *variables*. Thus if, as here,

$$y = f(z) \quad \text{and} \quad z = \psi(x)$$

we have

$$D_x y = D_z y \cdot D_x z.$$

8. Continuation : x^n , n Fractional.

The Laws of Fractional Exponents. Let $n = p/q$, where p and q are positive integers prime to each other, and consider the function

$$(17) \quad y = x^n = x^{\frac{p}{q}}$$

for positive values of x . If q is odd, the function is single-valued; but if q is even, there are two q th roots of x , and we might define the function of (17) to be double-valued, namely, as $\pm(\sqrt[q]{x})^p$. This is, however, inexpedient, and usage has determined that the notation (17) shall be defined to mean the positive root:

$$x^{\frac{p}{q}} = (\sqrt[q]{x})^p.$$

If n is a negative fraction, $n = -m$, then

$$x^n = \frac{1}{x^m}. \quad \text{Moreover, } a^0 = 1.$$

In Elementary Algebra the following laws of exponents are established:

$$(A) \quad \begin{cases} \text{I.} & a^m \cdot a^n = a^{m+n}; \\ \text{II.} & (a^m)^n = a^{mn}; \\ \text{III.} & a^n \cdot b^n = (ab)^n. \end{cases}$$

These laws hold without exception when a and b are both positive and m and n are any positive or negative integers or fractions, inclusive of 0.

Graph of the Function x^n . When n is an integer, $n = 1, 2, 3, \dots, 10, \dots$, the graphs are as indicated in Fig. 3; for the slope of the curve (17):

$$\tan \tau = D_x y = nx^{n-1}$$

is positive and increases steadily as x increases if $n > 1$.

Consider next the case that $p = 1, q > 1$. Here

$$(18) \quad y = x^{\frac{1}{q}}, \quad \text{or} \quad x = y^q,$$

and so, when $q = 2, 3, \dots, 10, \dots$, we get the same graphs as

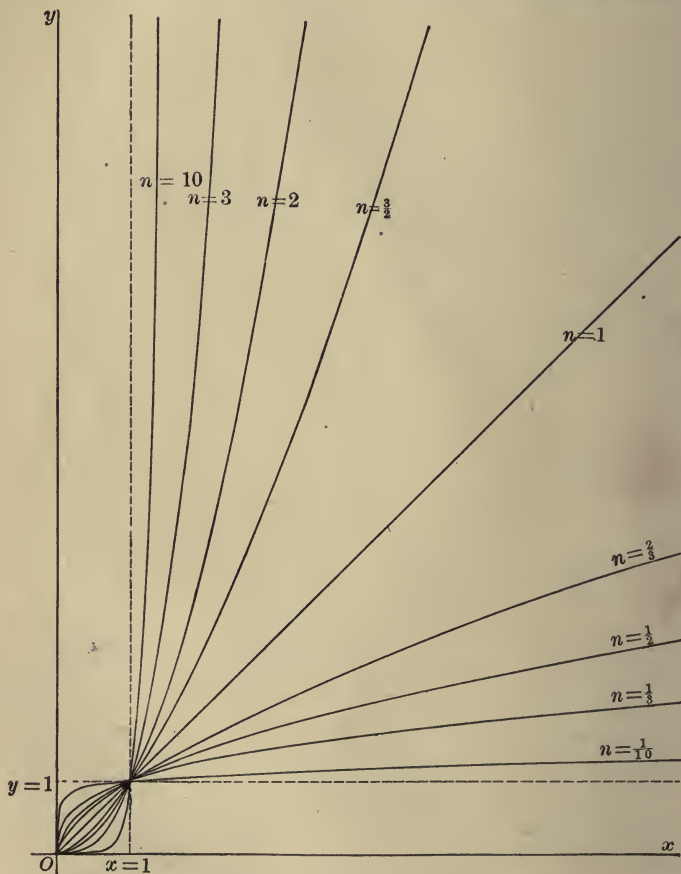

FIG. 3

when n is an integer, only drawn with y as the axis of abscissas and x as the ordinate, cf. Fig. 3. Thus any one of the latter

curves, as $y = x^{1/3}$, is obtained from the corresponding one of the former curves, $y = x^3$, by reflecting this curve in the bisector of the angle made by the positive coordinate axes.

The general case, $n = p/q$, will be taken up at the close of the paragraph.

Differentiation of x^n . Let us first find the slope of the curve (18). If σ denotes the angle between its tangent and the axis of y , then

$$\tan \sigma = D_y x = qy^{q-1}.$$

Now σ is the complement of τ , and so*

$$\tan \tau = \frac{1}{\tan \sigma}.$$

Hence
$$D_x y = \frac{1}{qy^{q-1}} = \frac{1}{q}y^{1-q}.$$

* This is equivalent to the relation :

$$D_x y = \frac{1}{D_y x}.$$

It is easy to give a proof of this relation as follows. If

$$y = f(x)$$

is any continuous function of x whose inverse function :

$$x = \psi(y)$$

is single-valued near the point (x_0, y_0) at which we are considering the derivatives, then

$$\frac{\Delta y}{\Delta x} = \frac{1}{\frac{\Delta x}{\Delta y}},$$

and hence, if $\lim \Delta x / \Delta y \neq 0$,

$$\lim_{\Delta x \neq 0} \frac{\Delta y}{\Delta x} = \frac{1}{\lim_{\Delta y \neq 0} \frac{\Delta x}{\Delta y}} \quad \text{or} \quad D_x y = \frac{1}{D_y x}, \quad \text{q. e. d.}$$

Replacing y by its value, $x^{1/q}$, we have :

$$y^{1-q} = (x^{\frac{1}{q}})^{1-q} = x^{\frac{1-q}{q}} = x^{\frac{1}{q}-1},$$

and thus

$$(19) \quad D_x x^{\frac{1}{q}} = \frac{1}{q} x^{\frac{1}{q}-1}.$$

This shows that Formula (12) holds even when $n = 1/q$.

Turning now to the general case :

$$y = x^{\frac{p}{q}},$$

let $z = x^{\frac{1}{q}}; \quad y = z^p.$

Then by Theorem V, § 5, and (19) :

$$D_x y = D_x z^p = D_x z^p \cdot D_x z = p z^{p-1} \cdot \frac{1}{q} x^{\frac{1}{q}-1},$$

$$z^{p-1} = (x^{\frac{1}{q}})^{p-1} = x^{\frac{p-1}{q}}.$$

Hence $D_x y = \frac{p}{q} x^{\frac{p-1}{q}} \cdot x^{\frac{1}{q}-1} = \frac{p}{q} x^{\frac{p}{q}-1},$

or

$$(20) \quad D_x x^n = n x^{n-1},$$

when n is any positive integer or fraction.

If n is a negative integer or fraction: $n = -m$,

then $x^n = \frac{1}{x^m},$

and hence x^n can be differentiated by the aid of Theorem IV, § 5 :

$$D_x \frac{1}{x^m} = \frac{x^m \cdot 0 - m x^{m-1}}{x^{2m}} = -m x^{-m-1},$$

or

$$D_x x^n = n x^{n-1}.$$

Consequently Formula (12) holds for all commensurable values of n . We shall show later that it holds for incommensurable values, too, and thus is true for any fixed value of n .

If $n = \frac{1}{2}$, we have

$$x^{\frac{1}{2}} = \sqrt{x}, \quad D_x x^{\frac{1}{2}} = \frac{1}{2} x^{-\frac{1}{2}} = \frac{1}{2\sqrt{x}},$$

which agrees with (16).

Example. To differentiate

$$y = \sqrt[3]{a^2 - x^2}.$$

Let
$$z = a^2 - x^2.$$

Then
$$y = z^{\frac{1}{3}},$$

$$D_x y = D_x z^{\frac{1}{3}} = D_x z^{\frac{1}{3}} D_x z = \frac{1}{3} z^{-\frac{2}{3}} (-2x) = \frac{-2x}{3(\sqrt[3]{a^2 - x^2})^2}.$$

Inequalities for x^n . If n is a positive integer, then

$$\text{I.} \quad \begin{cases} x^n > 1 & \text{when } x > 1; \\ x^n < 1 & \text{when } 0 \leq x < 1. \end{cases}$$

The same relations hold when $n = p/q$ is a positive fraction. For, suppose

$$y = x^{\frac{1}{q}} < 1 \quad \text{when } x > 1.$$

Then, by I,
$$y^q < 1.$$

But $y^q = x$, and $x < 1$ is contrary to hypothesis. Similarly when $x < 1$.

Finally, relations I. hold when $n = p/q$ is any positive fraction. For

$$x^{\frac{p}{q}} = (x^{\frac{1}{q}})^p,$$

and if $x > 1$, then

$$x^{\frac{1}{q}} > 1 \quad \text{and hence} \quad (x^{\frac{1}{q}})^p > 1.$$

Similarly for $x < 1$.

When, however, $n < 0$, the first inequality sign in each line of I. must be reversed and the value $x = 0$ excluded. The function x^n is nevertheless always positive when $x > 0$.

THEOREM. *If $n' > n$, then*

$$(a) \quad x^{n'} > x^n \quad \text{when} \quad x > 1;$$

$$(b) \quad x^{n'} < x^n \quad \text{when} \quad x < 1.$$

Let $n' = n + h$. Then

$$x^{n'} - x^n = x^{n+h} - x^n = x^n(x^h - 1).$$

Since $h > 0$, we see from the relations I. that when $x > 1$, this last expression is positive; when $x < 1$, it is negative. Hence the theorem.

Graph of the Function x^n ; Conclusion. From the theorem just established it follows that the graphs of x^n for different positive fractional values of n lie as suggested in Fig. 3, namely: they all pass through the origin and the point (1, 1), and they have no other point of intersection. Their slope is always positive. Of two graphs corresponding to n and $n' > n$, the latter lies below the former when $x < 1$; above it when $x > 1$.*

The student is requested to write out similar statements for the case that $n < 0$, and to draw the graphs. It is better, however, not to complicate Fig. 3 with these latter graphs, but to deduce them when needed from Fig. 3. Thus confusion will be avoided. Fig. 3 should be permanently visualized. The student should construct such a figure for himself accurately on coordinate paper, using the tables of squares and cubes.

* These curves penetrate every part (a) of the square, the coordinates of whose points (x, y) satisfy the relations:

$$0 < x < 1, \quad 0 < y < 1,$$

and (b) of the interior of the right angle of Fig. 3:

$$1 < x, \quad 1 < y.$$

When we include the curves for which n is positive and incommensurable, the complete family $y = x^n$ thus obtained just fills these regions without overlapping. For a proof of these statements see the Appendix.

EXERCISES

Differentiate the following functions :

1. $y = 10x^{\frac{2}{3}} - 4x^{-\frac{1}{2}} - 1.$

4. $y = \sqrt[3]{ax^2}.$

2. $y = x^{\frac{2}{3}} - x^{-\frac{1}{5}} + \pi.$

5. $y = \frac{1 - x^{-1/2}}{x^{1/5}}.$

3. $\frac{1 + x^2}{\sqrt[3]{x}}.$

6. $y = x\sqrt{2x}.$

7. $y = \frac{1}{\sqrt[3]{a^2 - x^2}}. \quad D_x y = \frac{2x}{3(a^2 - x^2)^{\frac{4}{3}}}.$

8. $\dot{y} = x(1 - x^2)^{\frac{3}{7}}.$

9. $4\sqrt[3]{t^2} + \frac{3}{\sqrt{t}} - \frac{1}{t}.$

10. $(y^2 + 1)\sqrt{y^3 - y}. \quad \text{Ans.} \quad \frac{7y^4 - 2y^2 - 1}{2(y^3 - y)^{\frac{1}{2}}}.$

11. $\sqrt[3]{\frac{1 - x}{(1 + x)^2}}.$

13. $\frac{x^c + x^d}{cd}.$

12. $x^a - ax + a.$

14. $x^{a+b} - x^{a-b}.$

15. $\frac{(s^2 - a^2)^{\frac{3}{2}}}{s^3}. \quad \text{Ans.} \quad \frac{3a^2\sqrt{s^2 - a^2}}{s^4}.$

16. $\frac{a - x}{\sqrt{2ax - x^2}}.$

17. $r = \sqrt{a\theta}.$

18. $\frac{\sqrt{a-x} + \sqrt{a+x}}{\sqrt{a-x} - \sqrt{a+x}}. \quad \text{Ans.} \quad \frac{a^2 + a\sqrt{a^2 - x^2}}{x^2\sqrt{a^2 - x^2}}.$

 19. Find the slope of the curve $y = x^{\frac{1}{5}}$ in the point whose abscissa is 2, correct to three significant figures.

Ans. $\tan \tau = .115.$

 20. If $pv^{1.4} = C$, find $D_v p$.

 21. If $y\sqrt{x} = 1 + x$, find $D_x y$.

Ans. $\frac{x-1}{2x\sqrt{x}}.$

9. **Differentiation of Algebraic Functions.** When x and y are connected by such a relation as

$$x^2 + y^2 = a^2$$

or
$$x^3 - xy + y^5 = 0$$

or
$$xysin y = x + y \log x,$$

i.e. if y is given as a function of x by the equation

$$F(x, y) = 0$$

or its equivalent, $\Phi(x, y) = \Psi(x, y)$, where neither Φ nor Ψ reduces to y , then y is said to be an *implicit function* of x . If we solve the equation for y , thus obtaining:

$$y = f(x),$$

y thereby becomes an *explicit function* of x . It is often difficult or impossible to effect the solution; but even when it is possible, it is usually easier to differentiate the function in the implicit form. Thus in the case of the first example we have, on differentiating the equation as it stands with respect to x :

$$D_x x^2 + D_x y^2 = D_x a^2$$

or
$$2x + 2y D_x y = 0.$$

Hence
$$D_x y = -\frac{x}{y}.$$

If we differentiate the second equation in a similar manner, we get:

$$3x^2 - x D_x y - y + 5y^4 D_x y = 0.$$

Solving for $D_x y$, we obtain:

$$D_x y = -\frac{3x^2 - y}{5y^4 - x}.$$

When $F(x, y)$ is a polynomial in x and y , the function y , defined by the equation

$$F(x, y) = 0$$

is called an *algebraic function*. Thus all polynomials and fractional rational functions are algebraic. Moreover, all functions expressed by radicals, as

$$y = \sqrt{a^2 - x^2} \quad \text{or} \quad y = \sqrt[3]{\frac{1-x}{1+x}} - \sqrt[5]{4 - \sqrt{x}},$$

are algebraic, for the radicals can be eliminated and the resulting equation brought into the above form. But the converse is not true: not all algebraic equations can be solved by means of radicals.

It can be shown that an algebraic function in general is continuous. In case the function is multiple-valued it can be considered as made up of a number of branches, each of which is single-valued and continuous. Assuming this theorem we can find the derivative of an algebraic function in the manner illustrated in the foregoing differentiations.

On the assumption just mentioned a short proof of Formula (12), § 2, can be given for the case that $n = p/q$. Since

$$y = x^{\frac{p}{q}}, \quad \text{we have:} \quad y^q = x^p.$$

Differentiate each side with respect to x :

$$D_x y^q = D_x x^p = p x^{p-1}.$$

Now
$$D_x y^q = D_y y^q \cdot D_x y = q y^{q-1} D_x y.$$

Hence
$$D_x y = \frac{p x^{p-1}}{q y^{q-1}} = \frac{p}{q} \frac{x^{p-1}}{x^{\frac{p}{q}(q-1)}} = \frac{p}{q} x^{\frac{p}{q}-1}.$$

The proof of this formula which we gave in § 8 does not depend on the above assumption, but is a complete proof.

EXERCISES

1. Differentiate y in both ways, where

$$xy + 4y = 3x,$$

and show that the results agree.

2. The same for $y^2 = 2mx$.

3. Find the slope of the curve

$$x^4 - 2xy^2 + y^5 = 13$$

at the point $(2, 1)$.

Ans. 10.

4. Show that the curves

$$3y = 2x + x^4y^3, \quad 2y + 3x + y^5 = x^3y$$

intersect at right angles at the origin.

CHAPTER III

APPLICATIONS

1. Tangents and Normals. The equation of a line passing through a point (x_0, y_0) and having the slope λ is

$$y - y_0 = \lambda(x - x_0),$$

and the equation of its perpendicular through the same point is

$$y - y_0 = -\frac{1}{\lambda}(x - x_0) \quad \text{or} \quad x - x_0 + \lambda(y - y_0) = 0.$$

Since the slope of a curve

$$y = f(x) \quad \text{or} \quad F(x, y) = 0.$$

in the point (x_0, y_0) is $[D_x y]_{x=x_0}$, the equation of the tangent line in that point is

$$(1) \quad y - y_0 = [D_x y]_{x=x_0}(x - x_0).$$

Similarly, the equation of the normal is seen to be:

$$(2) \quad y - y_0 = -\frac{1}{[D_x y]_{x=x_0}}(x - x_0) \quad \text{or} \quad x - x_0 + [D_x y]_{x=x_0}(y - y_0) = 0.$$

Example 1. To find the equation of the tangent to the curve

$$y = x^3$$

in the point $x = \frac{1}{2}, y = \frac{1}{8}$. Here

$$D_x y = 3x^2, \quad [D_x y]_{x=x_0} = [3x^2]_{x=\frac{1}{2}} = \frac{3}{4}.$$

Hence the equation of the tangent is

$$y - \frac{1}{8} = \frac{3}{4}(x - \frac{1}{2}) \quad \text{or} \quad 3x - 4y - 1 = 0.$$

Example 2. Let the curve be an ellipse:

$$\frac{x^2}{a^2} + \frac{y^2}{b^2} = 1.$$

Differentiating the equation as it stands, we get:

$$\frac{2x}{a^2} + \frac{2y}{b^2} D_x y = 0, \quad D_x y = -\frac{b^2 x}{a^2 y}.$$

Hence the equation of the tangent is

$$y - y_0 = -\frac{b^2 x_0}{a^2 y_0} (x - x_0).$$

This can be transformed as follows:

$$a^2 y_0 y - a^2 y_0^2 = -b^2 x_0 x + b^2 x_0^2,$$

$$b^2 x_0 x + a^2 y_0 y = a^2 y_0^2 + b^2 x_0^2 = a^2 b^2,$$

$$\frac{x_0 x}{a^2} + \frac{y_0 y}{b^2} = 1.$$

EXERCISES

1. Find the equation of the tangent of the curve

$$y = x^3 - x$$

at the origin; at the point where it crosses the positive axis of x .

$$\text{Ans. } x + y = 0; \quad 2x - y - 2 = 0.$$

2. Find the equation of the tangent and the normal of the circle

$$x^2 + y^2 = 4$$

at the point $(1, \sqrt{3})$ and check your answer.

3. Show that the equation of the tangent to the hyperbola

$$\frac{x^2}{a^2} - \frac{y^2}{b^2} = 1$$

at the point (x_0, y_0) is

$$\frac{x_0 x}{a^2} - \frac{y_0 y}{b^2} = 1.$$

4. Find the equation of the tangent to the curve

$$x^3 + y^3 = a^2(x - y)$$

at the origin.

$$\text{Ans. } x = y.$$

5. Show that the area of the triangle formed by the coordinate axes and the tangent of the hyperbola

$$xy = \alpha^2$$

at any point is constant.

6. Find the equation of the tangent and the normal of the curve

$$x^5 = \alpha^3 y^2$$

in the point distinct from the origin in which it is cut by the bisector of the positive coordinate axes.

7. Show that the portion of the tangent of the curve

$$x^{\frac{2}{3}} + y^{\frac{2}{3}} = a^{\frac{2}{3}}$$

at any point, intercepted between the coordinate axes is constant.

8. The parabola $y^2 = 2ax$ cuts the curve

$$x^3 - 3axy + y^3 = 0$$

at the origin and at one other point. Write down the equation of the tangent of each curve in the latter point.

9. Show that the curves of the preceding question intersect in the second point at an angle of $32^\circ 12'$.

2. Maxima and Minima.

Problem. Find the most advantageous length for a lever, by means of which to raise a weight of 100 lbs. (see Fig. 4), if the distance of the weight from the fulcrum is 2 ft. and the lever weighs 3 lbs. to the foot.

It is clear that, if we make the lever very long, the increased

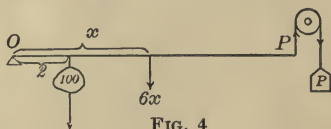

FIG. 4

weight of the lever will more than compensate for the gain in the leverage, and so the force P required to raise the weight will be large. On the other hand, if we make the lever very short, say 3 ft. long, the force required to lift the lever is slight, but there is little advantage from the leverage; and so,

again, the force P will be large. Evidently, then, there is an intermediate length that will give the best result, *i.e.* for which P will be least.

Let x denote the half-length of the lever. Then P is a function of x . If we determine this function, *i.e.* express P as a function of x , we can plot the graph and see where it comes nearest to the axis of x . Now the moments of the forces that tend to turn the lever about the fulcrum O in the clockwise direction are:

- (a) 100×2 , due to the weight of 100 lbs. ;
 (b) $3 \times 2x \times x$, due to the weight of the lever.

Hence their sum must equal the moment of P in the opposite direction, namely, $P \times 2x$, and thus

$$200 + 6x^2 = 2Px, \quad P = \frac{100 + 3x^2}{x}$$

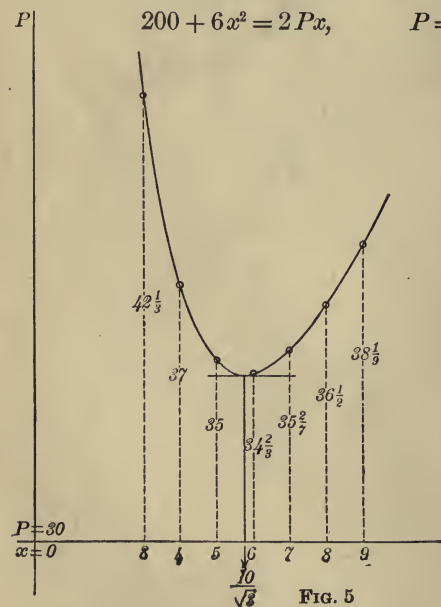

FIG. 5

Let us try a few values of x and see what the corresponding values of P are:

x	P
3	$42\frac{1}{3}$
4	37
5	35
6	$34\frac{2}{3}$
7	$35\frac{2}{7}$
8	$36\frac{1}{2}$
9	$38\frac{1}{9}$

From these figures it appears that the best length corresponds to a value of x between 5 and 7. By computing P for

a sufficiently large number of values of x intermediate between these two numbers, we could evidently approximate to the best value as closely as we wished. Can we not, however, with the aid of the Calculus, save ourselves the labor of these computations? Looking at the graph of the function, we see that the value of x we want to find is that one which corresponds to the smallest ordinate. This point of the curve is characterized by the fact that the tangent is here parallel to the axis of x and hence *the slope of the curve is 0*:

$$\tan \tau = D_x P = 0.$$

Let us compute, then, $D_x P$ and set it equal to 0:

$$D_x P = -\frac{100}{x^2} + 3 = 0,$$

$$x^2 = \frac{100}{3}, \quad x = \frac{10}{\sqrt{3}} = 5.77.$$

Consequently the best length for the lever is $2x = 11.4$ ft., the corresponding value of P being 34.6 lbs.

Example. A box is to be made out of a square piece of cardboard 4 in. on a side, by cutting out equal squares from the corners and turning up the sides. Find the dimensions of the largest box that can be made in this way.

First express the volume V of the box in terms of the length x of a side of one of the squares cut out, and plot the graph of V , thus determining approximately the best value for x . Then solve by the Calculus.

The foregoing examples suggest a simple test for a maximum or a minimum.

TEST FOR A MAXIMUM. *If the function*

$$y = f(x)$$

is continuous within the interval $a < x < b$ and has a larger value at one of the intermediate points than it does at or near each of the ends, then it has a maximum at some point $x = x_0$ within the interval.

Under the above conditions we shall have :

$$D_x y = 0 \quad \text{when} \quad x = x_0.$$

And if this equation has only one root in the above interval, then this root must be : $x = x_0$.*

The test for a minimum is similar, the words "larger" and "maximum" being merely replaced by "smaller" and "minimum."

EXERCISES

1. Find the least value of the function

$$y = x^2 + 6x + 10. \quad \text{Ans. } 1.$$

2. What is the greatest value of the function

$$y = 3x - x^3$$

for positive values of x ?

3. For what value of x does the function

$$\frac{12\sqrt{x}}{1+4x}$$

attain its largest value ?

$$\text{Ans. } x = \frac{1}{4}.$$

* It is true that there are exceptions to the test as stated, for the graph of a continuous function may have sharp corners, as shown in Fig. A.

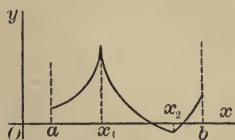

FIG. A

At such a point, however, the function has no derivative, since $\Delta y/\Delta x$ approaches no limit, as at $x = x_1$, or it approaches one limit when Δx approaches 0, passing only through positive values, and another limit when Δx approaches 0 from the negative side, as at $x = x_2$. If, then, we add the further condition to our test, that $f(x)$ shall have a derivative at each

point of the interval, no exception can possibly occur.

This condition is obviously fulfilled when, as is usually the case in practice, we are able to compute the derivative.

4. At what point of the interval $a < x < b$, a being positive, does the function

$$\frac{x}{(x-a)(b-x)}$$

attain its least value?

Ans. $x = \sqrt{ab}$.

5. The legs of an isosceles triangle are each 6 in. long. How long must the base be made in order that the area may be a maximum?

Ans. $6\sqrt{2} = 8\frac{1}{2}$ in.

6. A two-acre pasture in the form of a rectangle is to be fenced off along the bank of a straight river, no fence being needed on the river side. What must be its shape in order that the fence may cost as little as possible?

Ans. It must be twice as long as it is broad.

3. Continuation; Auxiliary Variables. It frequently happens that in formulating a problem in maxima and minima it is advisable to express the function which is to be made a maximum or a minimum in terms of two variables, between which a relation exists. The following example will illustrate the method.

To find the largest rectangle that can be inscribed in a circle.

It is evident that the area of the rectangle will be small when its altitude is small and also when its base is short. Hence the area will be largest for some intermediate shape.

From the equations:

$$u = 4xy, \quad x^2 + y^2 = a^2,$$

we could eliminate y and thus express u as a function of x . In practice, however, it is usually better not to eliminate, but to differentiate the equations as they stand:

$$D_x u = 4(y + xD_x y) = 0, \quad 2x + 2yD_x y = 0.$$

Hence

$$D_x y = -\frac{x}{y}.$$



FIG. 6

Substituting this value in the first equation, we get:

$$y - \frac{x^2}{y} = 0 \quad \text{or} \quad y = x,$$

i.e., the maximum rectangle is a square.

EXERCISES

1. A 100-gallon tank is to be built with a square base and vertical sides, and is to be lined with copper. Find the most economical proportions.

Ans. The length and breadth must each be double the height.

2. Find the greatest cylinder of revolution that can be inscribed in a given cone of revolution.

3. What is the cylinder of greatest convex surface that can be inscribed in the same cone?

4. Find the volume of the greatest cone of revolution that can be inscribed in a given sphere.

5. Find the most economical proportions for a cylindrical tin dipper which is to hold a pint. *Ans.* $h = r$.

6. What ought to be the shape of a tomato can to hold a quart and to require as little tin as possible for its manufacture?

7. If the top and bottom of the can are cut from sheets of tin in such a way that a regular hexagon is used up each time and the waste is a total loss, what will then be the best proportions?

8. A Norman window consists of a rectangle surmounted by a semicircle. If the perimeter of the window is given, what must be its proportions in order to admit as much light as possible? *Ans.* Breadth and height equal.

9. Work the last two questions of the preceding Exercises by the present method.

✓ 10. Assuming that the stiffness of a beam is proportional to its breadth and to the cube of its depth, find the dimensions of the stiffest beam that can be sawed from a log one foot in diameter.

✓ 11. If the cost per hour of running a certain steamboat in still water is proportional to the cube of the velocity, find the most economical rate at which to run the steamer up stream against a four-mile current. *Ans.* 6 m. per h.

12. The gate in front of a man's house is 20 yds. from the car track. If the man walks at the rate of 4 miles an hour and the car on which he is coming home is running at the rate of 12 miles an hour, where ought he to get off in order to reach home as early as possible?

13. If the cost per hour for the fuel required to run a given steamer is proportional to the cube of her speed and is \$20 an hour for a speed of 10 knots, and if other expenses amount to \$135 an hour, find the most economical rate at which to run her. *Ans.* 15 knots an hour.

✓ 14. A telegraph pole at a bend in the road is to be supported from tipping over by a stay 20 ft. long fastened to the pole and to a stake in the ground. How far from the pole ought the stake to be driven in?

15. How much water should be poured into a cylindrical tin dipper in order to bring the centre of gravity as low down as possible?

✓ 16. A man is in a row boat 3 miles from the nearest point A of a straight beach. He wishes to reach a point of the beach 5 miles from A in the shortest possible time. If he can walk at the rate of 4 miles an hour, but can row only 3 miles an hour, what point of the beach ought he to row for?

4. **Velocity.** By the *average velocity* with which a point moves for a given length of time t is meant the distance s traversed divided by the time:

$$\text{average velocity} = \frac{s}{t}.$$

Thus a railroad train which covers the distance between two stations 15 miles apart in half an hour has an average speed of $15/\frac{1}{2} = 30$ miles an hour.

When, however, the point in question is moving sometimes fast and sometimes slowly, we can describe its speed approximately at any given instant by considering a short interval of time immediately succeeding the instant t_0 in question, and taking the average velocity for this short interval.

For example, a stone dropped from rest falls according to the law:

$$s = 16t^2.$$

To find how fast it is going after the lapse of t_0 seconds. Here

$$(1) \quad s_0 = 16t_0^2.$$

A little later, at the end of t' seconds from the beginning of the fall,

$$(2) \quad s' = 16t'^2$$

and the average velocity for the interval of $t' - t_0$ seconds is

$$(3) \quad \frac{s' - s_0}{t' - t_0} \text{ ft. per sec.}$$

Let us consider this average velocity, in particular, after the lapse of 1 second:

$$t_0 = 1, \quad s_0 = 16.$$

Let the interval of time, $t' - t_0$, be $\frac{1}{10}$ sec. Then

$$s' = 16 \times 1.1^2 = 19.36,$$

$$\frac{s' - s_0}{t' - t_0} = \frac{3.36}{.1} = 33.6 \text{ ft. a sec.}$$

Next, let the interval of time be $\frac{1}{100}$ sec. Then a similar computation gives, to three significant figures:

$$\frac{s' - s_0}{t' - t_0} = 32.2 \text{ ft. a sec.}$$

And when the interval is taken as $\frac{1}{1000}$ sec., the average velocity is 32.0 ft. a sec.

Thus we can get at the speed of the stone at any desired instant to any desired degree of accuracy by direct computation; we need only to reckon out the average velocity for a sufficiently short interval of time succeeding the instant in question.

We can proceed in a similar manner when a point moves according to any given law. Can we not, however, by the aid of the Calculus avoid the labor of the computations and at the same time make precise exactly what is meant by *the velocity of the point at a given instant*? If we regard the interval of time $t' - t_0$ as an increment of the variable t and write $t' - t_0 = \Delta t$, then $s' - s_0 = \Delta s$ will represent the corresponding increment in the function, and thus we have:

$$\text{average velocity} = \frac{\Delta s}{\Delta t}.$$

Now allow Δt to approach 0 as its limit. Then the average velocity will in general approach a limit, and *this limit we take as the definition of the velocity v at the instant t_0* :

$$\begin{aligned} \lim (\text{average velocity from } t = t_0 \text{ to } t = t') \\ = \text{actual velocity at instant } t = t_0, \end{aligned}$$

or

$$v = \lim_{\Delta t \rightarrow 0} \frac{\Delta s}{\Delta t} = D_t s.$$

Hence it appears that the velocity of a point is the time derivative of the space it has travelled.

Similarly, the rate at which the distance between two points, one or both of which are moving, is changing is the derivative of their distance apart with respect to the time; see Ex. 4 below. And the rate at which any quantity is changing is its time derivative, as in Ex. 3.

EXERCISES

1. The height of a stone thrown vertically upward is given by the formula :

$$s = 48t - 16t^2.$$

When it has been rising for one second, find (a) its average velocity for the next $\frac{1}{10}$ sec.; (b) for the next $\frac{1}{100}$ sec.; (c) its actual velocity at the end of the first second; (d) how high it will rise.

Ans. (a) 14.4 ft. a sec.; (b) 15.84 ft. a sec.; (c) 16 ft. a sec.; (d) 36 ft.

2. A man 6 ft. tall walks directly away from a lamp-post 10 ft. high at the rate of 4 miles an hour. How fast is the further end of his shadow moving along the pavement?

Ans. 10 miles an hour.

3. Find the rate at which the shadow in the preceding problem is lengthening.

4. The rays of the sun make an angle of 30° with the horizon. A ball is thrown vertically upward to a height of 64 ft. How fast is its shadow on the ground travelling just before the ball strikes the ground?

Ans. 111 ft. a sec.

5. Two ships start from the same port at the same time. One ship sails east at the rate of 9 knots an hour, the other south at the rate of 12 knots. How fast are they separating at the end of 2 hours?

Ans. 15 knots an hour.

6. If in the preceding question the first ship starts an hour ahead of the second ship, how fast will they be separating an hour after the second ship leaves port?

7. One ship is 20 miles due north of another ship at noon, and is sailing south at the rate of 10 knots an hour. The second ship sails west at the rate of 12 knots an hour. How long will the ships continue to approach each other?

8. A stone is dropped into a placid pond and sends out a series of concentric circular ripples. If the radius of the outer ripple increases steadily at the rate of 6 ft. a sec., how rapidly is the area of the water disturbed increasing at the end of 2 sec. ? *Ans.* 452 sq. ft. a sec.

9. A man is walking over a bridge at the rate of 4 miles an hour, and a boat passes under the bridge immediately below him rowing 8 miles an hour. The bridge is 20 ft. above the boat. How fast are the boat and the man separating 3 minutes later ?

5. Increasing and Decreasing Functions. The Calculus affords a simple means of determining whether a function is increasing or decreasing as the independent variable increases. Since the slope of the graph is given by $D_x y$, we see that, when $D_x y$ is positive, y increases as x increases, but when $D_x y$ is negative, y decreases as x increases. Fig. 7 shows the graph in general when $D_x y$ is positive.

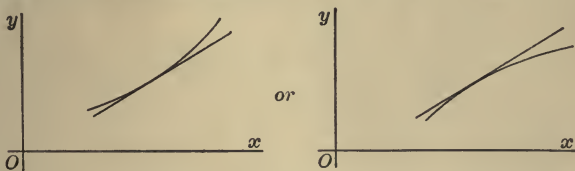

FIG. 7

THEOREM: *When x increases, then*

- (a) if $D_x y > 0$, y increases ;
- (b) if $D_x y < 0$, y decreases.

As an application consider the condition that a curve $y = f(x)$ have its concave side turned upward, as in Fig. 8. The slope of the curve is a function of x :

$$\tan \tau = \phi(x).$$

Consider the tangent line at a variable point P . If we think of P as tracing out the curve and carrying

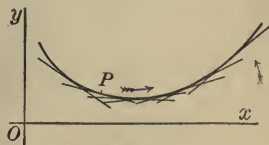

FIG. 8

the tangent along with it, the tangent will turn in the counter clock-wise sense, the slope thus increasing algebraically as x increases, whenever the curve is concave upward. And conversely, if the slope increases as x increases, the tangent will turn in the counter clock-wise sense and the curve will be concave upward. Now by the above theorem, when

$$D_x \tan \tau > 0,$$

$\tan \tau$ increases as x increases. Hence the curve is concave upward, when $D_x \tan \tau$ is positive.

The derivative $D_x \tan \tau$ is the derivative of the derivative of y . This is called the *second derivative of y* :

$$D_x(D_x y) = D_x^2 y$$

(read: " D x second of y ").*

The test for the curve's being concave downward is obtained in a similar manner, and thus we are led to the following important theorem.

TEST FOR A CURVE'S BEING CONCAVE UPWARD, ETC. *The curve*

$$y = f(x)$$

is CONCAVE UPWARD when $D_x^2 y > 0$;

CONCAVE DOWNWARD when $D_x^2 y < 0$.

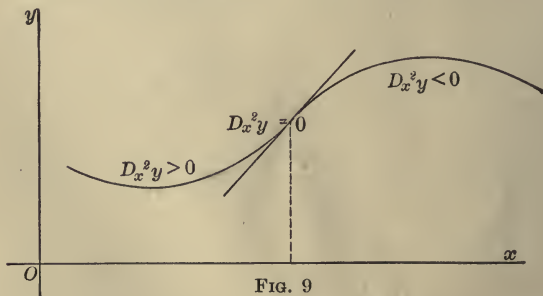

FIG. 9

* The derivative of the second derivative, $D_x(D_x^2 y)$, is called the *third derivative* and is written $D_x^3 y$, and so on.

A point at which the curve changes from being concave upward and becomes concave downward (or *vice versa*) is called a *point of inflection*. Since D_x^2y changes sign at such a point, this function will necessarily, if continuous, vanish there. Hence:

A necessary condition for a point of inflection is that

$$D_x^2y = 0.$$

6. Curve Tracing. In the early work of plotting curves from their equations the only way we had of finding out what the graph of a function looked like was by computing a large number of its points. We are now in possession of powerful methods for determining the character of the graph with scarcely any computation. For, first, we can find the slope of the curve at any point; and secondly we can determine in what intervals it is concave upward, in what concave downward.

As an example let us plot the graph of the function :

$$(1) \quad y = x^3 + px + q.$$

Consider first the case $q = 0$:

$$(2) \quad y = x^3 + px.$$

Here $D_x y = 3x^2 + p,$

$$D_x^2 y = 6x.$$

From the last equation it follows that the curve is concave upward for all positive values of x . Moreover, when x becomes positively infinite, $D_x y$ also becomes positively infinite, no matter what value p may have. The curve goes through the origin and its slope there is

$$[D_x y]_{x=0} = p.$$

Hence the graph is, in character, for positive values of x as shown in Fig. 10.

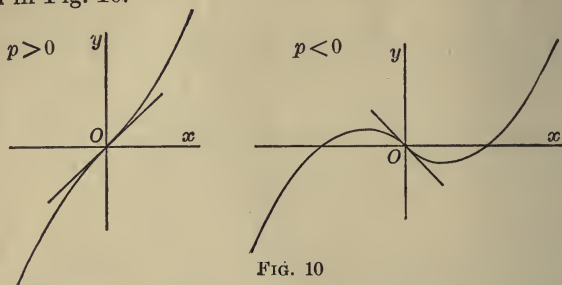

FIG. 10

To obtain the graph for negative values of x we need only observe that the curve is symmetric with respect to the origin. For, if (x, y) be any point of the curve, then $x' = -x$, $y' = -y$ is also a point of the curve. When, therefore, we have once plotted the curve for positive values of x , we need only to rotate the graph through 180° about the origin in order to get the remainder of the curve.

Finally we can get the graph of (1) from that of (2) by merely shifting the axis of x to a parallel axis. The formulas for this transformation are :

$$x = x', \quad y = y' - q.$$

Thus (2) becomes :

$$y' - q = x'^3 + px'.$$

Transposing q and dropping the accents, we get equation (1). This curve is symmetric with respect to the point $x = 0, y = q$.

EXERCISES

Use coordinate paper in working these exercises.

1. Show that the curve

$$y = \frac{3}{3 + x^2}$$

is concave downward in the interval $-1 < x < 1$ and concave upward for all other values of x . Find its slope in its points of

inflection and draw the tangent line in each of these points. Hence plot the curve.

2. Plot the curve

$$4y = x^4 - 6x^2 + 8,$$

determining

- (a) its intersections with the coordinate axes;
- (b) the intervals in which it is concave upward and those in which it is concave downward;
- (c) its points of inflection;
- (d) the points where its tangent is parallel to the axis of x .

Plot the points (a), (c), (d) accurately, using a scale of 2 cm. as the unit, and draw accurately the tangent in each of these points. Hence construct the curve.

Plot the following curves:

3. $10y = x^3 - 12x + 9.$

Note that the curve cuts the axis of x in the point $x = 3$.

4. $y = x^3 + 2x^2 - 13x + 10.$

9. $y^2 = x^2 + x^3.$

5. $y = x - x^5.$

10. $y^2 = x(x-1)(x-2).$

6. $y = \frac{x}{1+x^2}.$

11. $y = \frac{1}{1-x^2}.$

7. $y = \frac{x^2}{1+x^2}.$

12. $y^2 = \frac{x}{1-x}.$

8. $y = \frac{1}{1-x}.$

13. $y^2 = \frac{x^2}{1+x^2}.$

7. Relative Maxima and Minima. Points of Inflection. A function

(1) $y = f(x)$

is said to have a *maximum* at a point $x = x_0$ if its value at x_0 is larger than at any other point in the neighborhood of x_0 . But such a maximum need not represent the largest value of the

function in the complete interval $a \leq x \leq b$, as is shown by Fig. 11, and for this reason it is called a *relative maximum*, in

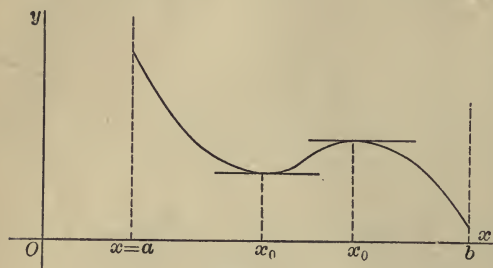

FIG. 11

distinction from a maximum maximum, or an absolute maximum.

A similar definition holds for a minimum, the word "larger" being merely replaced by "smaller."

It is obvious that a characteristic feature of a maximum is that the tangent is parallel to the axis of x , the curve being concave downward. Similarly for a minimum, the curve here being concave upward. Hence the following

TEST FOR A MAXIMUM OR A MINIMUM. *If*

$$(a) \quad [D_x y]_{x=x_0} = 0, \quad [D_x^2 y]_{x=x_0} < 0,$$

the function has a maximum for $x = x_0$; if

$$(b) \quad [D_x y]_{x=x_0} = 0, \quad [D_x^2 y]_{x=x_0} > 0,$$

it has a minimum.

This condition is sufficient, but not necessary. Thus the function

$$(2) \quad y = x^4$$

evidently has a minimum at the point $x = 0$. But here $D_x^2 y$ is not positive, but $= 0$. Still, the above test is adequate for the great majority of cases that arise in practice. We shall obtain a more general test later.

Example. Let

$$y = x^6 - 3x^2 + 1.$$

Here $D_x y = 6x^5 - 6x = 6x(x^2 - 1)(x^2 + 1)$,

and hence $D_x y = 0$ for $x = -1, 0, 1$.

Furthermore, $D_x^2 y = 30x^4 - 6$.

Thus

$$[D_x^2 y]_{x=-1} = 24 > 0, \quad \therefore x = -1 \text{ gives a } \textit{minimum};$$

$$[D_x^2 y]_{x=0} = -6 < 0, \quad \therefore x = 0 \quad \text{“} \quad \text{“} \quad \textit{maximum};$$

$$[D_x^2 y]_{x=1} = 24 > 0, \quad \therefore x = 1 \quad \text{“} \quad \text{“} \quad \textit{minimum}.$$

As a further application of the test just found let us obtain a *sufficient* condition for a point of inflection. We have seen that a *necessary* condition is that $D_x^2 y = 0$; but this is not sufficient, as the example of the function (2) above shows. A geometric feature characteristic of a point of inflection is that the tangent ceases rotating in one direction and, turning back, begins to rotate in the opposite direction. Hence the slope of the curve, $\tan \tau$, has either a maximum or a minimum at a point of inflection.

Conversely, if $\tan \tau$ has a maximum or a minimum, the curve will have a point of inflection. For, suppose $\tan \tau$ is at a maximum when $x = x_0$. Then as x , starting with the value x_0 , increases, $\tan \tau$, *i.e.* the slope of the curve, decreases algebraically, and so the curve is concave downward to the right of x_0 . On the other hand, as x decreases, $\tan \tau$ also decreases, and so the curve is concave upward to the left of x_0 .

Now, by the above theorem, $\tan \tau$ will have a maximum or a minimum if

$$D_x \tan \tau = 0, \quad D_x^2 \tan \tau \neq 0.$$

Hence, remembering that

$$\tan \tau = D_x y,$$

we obtain the following

TEST FOR A POINT OF INFLECTION. *If*

$$[D_x^2 y]_{x=x_0} = 0, \quad [D_x^3 y]_{x=x_0} \neq 0,$$

the curve has a point of inflection at $x = x_0$.

This test, like the foregoing for a maximum or a minimum, is sufficient, but not necessary.

Example. Let

$$12y = x^4 + 2x^3 - 12x^2 + 14x - 1.$$

Then

$$12 D_x y = 4x^3 + 6x^2 - 24x + 14,$$

$$12 D_x^2 y = 12x^2 + 12x - 24 = 12(x-1)(x+2),$$

$$12 D_x^3 y = 12(2x+1).$$

Setting $D_x^2 y = 0$, we get the points $x = 1$ and $x = -2$. And since

$$12[D_x^3 y]_{x=1} = 36 \neq 0, \quad 12[D_x^3 y]_{x=-2} = -36 \neq 0,$$

we see that both of these points are points of inflection.

The slope of the curve in these points is given by the equations:

$$12[D_x y]_{x=1} = 0, \quad 12[D_x y]_{x=-2} = 54.$$

Hence the curve is parallel to the axis of x at the first of these points; at the second its slope is $4\frac{1}{2}$.

EXERCISES

Test the following curves for maxima, minima, and points of inflection, and determine the slope of the curve in each point of inflection.

1. $y = 4x^3 - 15x^2 + 12x + 1.$ ✓ 4. $y = (x-1)^3(x+2)^2.$

2. $y = x^3 + x^4 + x^5.$ ✓ 5. $y = \frac{x}{2+3x^2}.$

3. $6y = x^6 - 3x^4 + 3x^2 - 1.$ 6. $y = (1-x^2)^3.$



FIG. 12

✓ 7. Deduce a test for distinguishing between two such points of inflection as those indicated in Fig.

12.

8. On the Roots of Equations. The problem of solving the equation

$$f(x) = 0$$

can be formulated geometrically as follows: To find the points of intersection of the curve

$$y = f(x)$$

with the axis of x :

$$y = 0.$$

Hence we see that we can approximate to the roots as closely as we please by plotting the curve with greater and greater accuracy near the points where it meets the axis of x .

It is often a matter of importance to know how many roots there are in a given interval; for example, the number of positive roots that an equation possesses. One means of answering this question is by the methods of curve tracing above set forth.

Consider, for example, the equation:

$$x^6 - 3x^2 + 1 = 0.$$

The function

$$y = x^6 - 3x^2 + 1$$

is positive for values of x that are numerically large. For

$$y = x^6 \left(1 - \frac{3}{x^4} + \frac{1}{x^6} \right).$$

Here the parenthesis approaches a positive limit when x increases without limit; the x^6 factor increases without limit, and so the product increases without limit.

Again, the function has a maximum when $x = 0$ (see § 7), its value there being positive, namely 1; and at $x = 1$ it has a minimum, its value there being negative. Consequently the curve must have crossed the positive axis of x between $x = 0$ and $x = 1$, and again when $x > 1$, and so the above equation has at least two positive real roots. Has it more?

In the interval $0 < x < 1$

$$D_x y = 6x(x^2 - 1)(x^2 + 1)$$

is negative and hence the function is steadily decreasing. The graph, therefore, can have crossed the axis of x but once. Again, when $x > 1$, $D_x y$ is positive, and so the function is always increasing. Hence the graph can have crossed the axis of x beyond this point but once.

Thus we see that the equation has just two positive roots, and since to each root $x = a$ corresponds a second root $x = -a$, it has just two nega-

tive roots, and so in all just four real roots.

A general principle is illustrated in this example, which may be stated as follows.

THEOREM. *If a continuous function $f(x)$ changes sign in an interval $a < x < b$ and if its derivative is positive at all points of the interval (or negative at all points of the interval), then the function vanishes at just one point of the interval.*

The cubic equation

$$(1) \quad x^3 + px + q = 0$$

can be treated in a similar manner. The graph of the function

$$(2) \quad y = x^3 + px$$

studied in § 6 was especially simple. The points in which this curve is cut by the line

$$(3) \quad y = -q$$

evidently have for their abscissas the roots of the cubic (1).* Now if $p \geq 0$, the graph will correspond to the first of the two

* Another geometric formulation of the problem of finding the roots of the cubic (1) is to consider the intersections of the curves

$$y = x^3, \quad y = -px - q.$$

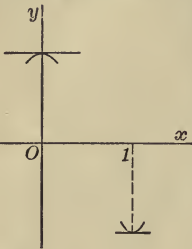

FIG. 13

figures in Fig. 10. Thus the line (3) will cut the curve (2) in just one point, and so equation (1) will have just one real root.* But if $p < 0$, then the graph corresponds to the second figure in Fig. 10, and we see that it depends on the relative magnitudes of p and q as to whether there are three points of intersection or fewer.

The maxima and minima of the function (2) are obtained by setting

$$D_x y = 3x^2 + p = 0, \quad x = \pm \sqrt{-\frac{p}{3}},$$

and it turns out that a minimum occurs at the point †

$$x = \sqrt{-\frac{p}{3}}, \quad y = \frac{2p}{3} \sqrt{-\frac{p}{3}},$$

a maximum at

$$x = -\sqrt{-\frac{p}{3}}, \quad y = -\frac{2p}{3} \sqrt{-\frac{p}{3}}.$$

Hence if q is numerically greater than these equal and opposite values of y , *i.e.* if

$$q^2 > -\frac{4p^3}{27},$$

the cubic (1) will have one real root. If q , however, is numerically smaller:

$$q^2 < -\frac{4p^3}{27},$$

it will have three real roots; and if

$$q^2 = -\frac{4p^3}{27},$$

it will have two real roots, one of which counts twice, except in the case above mentioned, $p = q = 0$, where it has one triple root.

The first is a special cubic, which can be plotted accurately from the tables once for all; and then the straight line can be drawn as soon as p and q are assigned special values. Thus we get a graphical solution for any cubic of the above type.

* In the special case: $p = 0$, $q = 0$, the cubic (1) reduces to $x^3 = 0$. It is customary to say that this equation has three coincident roots.

† Observe that $p < 0$, so that $\frac{2}{3}p\sqrt{-p/3}$ is negative and, further down, $-4p^3/27$ is positive.

We can collect all cases under the following

THEOREM. *The cubic equation*

$$x^3 + px + q = 0$$

has

(a) 1 real root when $\frac{q^2}{4} + \frac{p^3}{27} > 0;$

(b) 3 " " " " $< 0;$

(c₁) 2 " " " " $= 0, \begin{cases} p \text{ and } q \text{ not} \\ \text{both} = 0. \end{cases}$

(c₂) 1 " " " " " $\begin{cases} p = q = 0. \end{cases}$

In case (c₁) one root counts twice; and in (c₂) the root counts three times.

EXERCISES

1. How many real roots has each of the following equations?

(a) $x^5 - 5x - 1 = 0.$

(c) $3x^4 - 4x^3 + 12x^2 + 7 = 0.$

(b) $3x^4 + 4x^3 + 6x^2 - 1 = 0.$

(d) $x^{2n+1} + px + q = 0.$

Ans. (a) three; (b) two; (c) none.

2. How many real roots have the cubics:

(a) $x^3 + 7x - 1 = 0;$

(c) $x^3 - 3x - 2 = 0;$

(b) $x^3 - 4x + 1 = 0;$

(d) $x^3 - x + 3 = 0?$

3. How many positive roots has the equation

$$6x^4 + 8x^3 - 12x^2 - 24x - 1 = 0? \quad \text{Ans. One.}$$

4. Show that the function

$$f(x) = \frac{3}{(x-1)^8} + \frac{7}{(x-2)^9}$$

has just one root in the interval $1 < x < 2.$

5. How many real roots has the equation

$$4x^3 - 15x^2 + 12x + 1 = 0? \quad \text{Ans. Three.}$$

6. Show that, by a suitable transformation of the coordinate axes to parallel axes, the new origin being on the axis of x , namely :

$$x = x' + h, \quad y = y',$$

the equation :

$$y = x^3 + p_1 x^2 + p_2 x + p_3$$

can be carried over into the equation :

$$y = x^3 + px + q.$$

Hence obtain the condition that the cubic :

$$x^3 + p_1 x^2 + p_2 x + p_3 = 0$$

have three real roots.

5. 5/10/22

CHAPTER IV

DIFFERENTIATION OF TRANSCENDENTAL FUNCTIONS

1. **Differentiation of $\sin x$.** *First Method.* The graph of the function

$$(1) \quad y = \sin x$$

can be constructed geometrically by drawing a circle of unit radius and measuring the ordinates corresponding to different

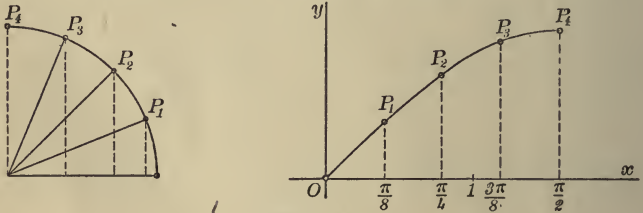

FIG. 14

angles; the angle itself, measured in radians, giving the abscissa and being computed arithmetically.

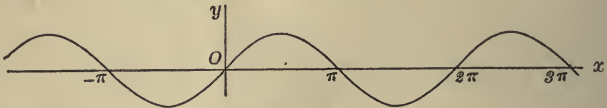

FIG. 15

In order to differentiate $\sin x$ we have to give to x an arbitrary value x_0 and compute the corresponding value of y :

$$y_0 = \sin x_0.$$

Then give x an increment, Δx , and compute again the corresponding value of y :

$$y_0 + \Delta y = \sin(x_0 + \Delta x).$$

Hence
$$\Delta y = \sin(x_0 + \Delta x) - \sin x_0,$$

(2)
$$\frac{\Delta y}{\Delta x} = \frac{\sin(x_0 + \Delta x) - \sin x_0}{\Delta x}.$$

Let us follow these steps geometrically by constructing the successive magnitudes. Fig. 16 explains itself. The radius of the circle is unity, and so

$$MP = \sin x_0, \quad M'P' = \sin(x_0 + \Delta x).$$

$$QP' = \sin(x_0 + \Delta x) - \sin x_0 = \Delta y, \quad \overline{PP'} = \Delta x.$$

Hence

(3)
$$\frac{\Delta y}{\Delta x} = \frac{QP'}{\overline{PP'}}.$$

Now it is easy to see what limit this last ratio approaches when P' approaches P . Suppose first we had in the denominator the chord $\overline{PP'}$. Then

$$\frac{QP'}{\overline{PP'}} = \sin \phi,$$

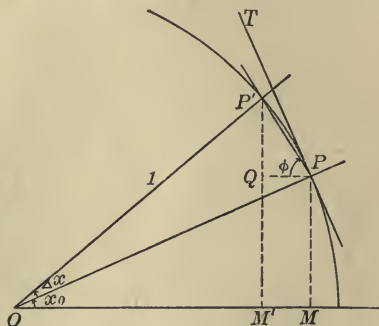

FIG. 16

and since
$$\lim_{P' \rightarrow P} \phi = \angle QPT = \frac{\pi}{2} - x_0,$$

it follows that

$$\lim_{P' \rightarrow P} \frac{QP'}{\overline{PP'}} = \cos x_0.$$

The chord of a small angle differs, however, from the arc only by a small percentage of either. We readily see that

(4)
$$\lim_{P' \rightarrow P} \frac{\overline{PP'}}{\overline{PP'}} = 1.$$

The student is requested to draw an accurate figure representing the arc and the chord of an angle of 30° and also of 15° .

Returning now to the ratio (3) and writing it in the form :

$$\frac{\overbrace{QP'}^{\text{opposite}}}{\underbrace{PP'}^{\text{hypotenuse}}} = \frac{QP'}{PP'} \cdot \frac{\overline{PP'}}{\underbrace{PP'}^{\text{hypotenuse}}},$$

we have, when P' approaches P as its limit :

$$\lim_{\Delta x \neq 0} \frac{\Delta y}{\Delta x} = \left(\lim_{P' \neq P} \frac{QP'}{PP'} \right) \left(\lim_{P' \neq P} \frac{\overline{PP'}}{\underbrace{PP'}^{\text{hypotenuse}}} \right) = \cos x_0,$$

or dropping the subscripts :

$$(5) \quad D_x \sin x = \cos x.$$

EXERCISE

Prove in a similar manner that

$$(6) \quad D_x \cos x = -\sin x.$$

Second Method. The foregoing method has the advantage of being easily remembered. Each analytic step is mirrored in a simple geometric construction. It has the disadvantage, however, of incompleteness. For, first, we have allowed Δx , in approaching 0, to pass through only positive values; and secondly we have assumed x_0 to lie between 0 and $\pi/2$. Hence there are in all seven more cases to consider.

An analytic method that is simple and at the same time general is the following. Recall the Addition Theorem for the sine:

$$\sin(a+b) = \sin a \cos b + \cos a \sin b,$$

$$\sin(a-b) = \sin a \cos b - \cos a \sin b,$$

whence

$$\sin(a+b) - \sin(a-b) = 2 \cos a \sin b,$$

and let

$$a+b = x_0 + \Delta x, \quad a-b = x_0.$$

Solving these last equations for a and b , we get:

$$a = x_0 + \frac{\Delta x}{2}, \quad b = \frac{\Delta x}{2}.$$

Thus $\sin(x_0 + \Delta x) - \sin x_0 = 2 \cos\left(x_0 + \frac{\Delta x}{2}\right) \sin \frac{\Delta x}{2}$,

and the difference-quotient (2) becomes :

$$\frac{\Delta y}{\Delta x} = \cos\left(x_0 + \frac{\Delta x}{2}\right) \frac{\sin \frac{\Delta x}{2}}{\frac{\Delta x}{2}}.$$

The limit of the first factor on the right is $\cos x_0$. The limit of the second is of the form :

$$\lim_{\alpha \neq 0} \frac{\sin \alpha}{\alpha},$$

and here, again, we have to

do with the limit of the ratio of the arc to the chord. For, in Fig. 17 :

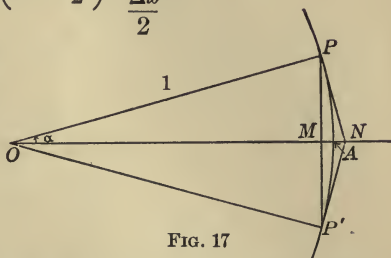

FIG. 17

$$\overline{PP'} = 2 \sin \alpha, \quad \overset{\frown}{PP'} = 2 \alpha.$$

We have seen that the limit (4) has the value 1 by direct inspection of the figure. We can give a formal proof based on the axioms of geometry as follows. First of all, a straight line is the shortest distance between two points, and so

$$\overline{PP'} < \overset{\frown}{PP'}.$$

Secondly, if we draw the tangents at P and P' , meeting in N , we have, by the axiom that a convex curved line is shorter than a convex broken line that envelops it and has the same extremities :

$$\overset{\frown}{PP'} < PN + NP' = 2PN.$$

Hence

$$\overline{PP'} < \overset{\frown}{PP'} < 2PN.$$

Dividing through by $\overline{PP'} = 2PM$, and noticing that

$$\frac{PN}{PM} = \frac{1}{\cos \alpha},$$

we obtain :

$$1 < \frac{\overset{\frown}{PP'}}{\overline{PP'}} < \frac{1}{\cos \alpha}.$$

When α approaches 0, $1/\cos \alpha$ approaches 1, and thus the variable $\overline{PP'}/\overline{PP'}$ is seen to lie between the fixed value 1 and a variable number which is approaching 1 as its limit. Consequently

$$\lim_{\overline{PP'} \rightarrow 0} \frac{\overline{PP}}{\overline{PP'}} = 1, \quad \text{q. e. d.}$$

The reciprocal of this ratio, $\overline{PP'}/\overline{PP}$, must, as was pointed out in Chap. II, § 5, under Theorem C, also approach unity as its limit.

Another Proof of (4). The area of the sector OAP , Fig. 18, is $\frac{1}{2}\alpha$, and it obviously lies between the areas of the triangles OMP and OAQ . Hence

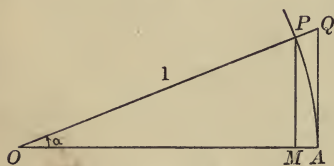

FIG. 18

$$\frac{1}{2} \sin \alpha \cos \alpha < \frac{1}{2} \alpha < \frac{1}{2} \tan \alpha$$

or

$$\cos \alpha < \frac{\alpha}{\sin \alpha} < \frac{1}{\cos \alpha}.$$

When α approaches 0, each of the extreme terms approaches 1, and so the middle term must also do so, q. e. d.

From Peirce's *Tables*, p. 130, we see that

$$\sin 4^{\circ}40' = .0814,$$

and the same angle, measured in radians, also has the value .0814, to three significant figures. Thus for values of α not exceeding $4^{\circ}40'$, $\sin \alpha$ differs from α by less than one part in 800, or one-eighth of one per cent.

Reason for the Radian. The reason for measuring angles in terms of the radian as the unit now becomes clear. Had we used the degree, the increment Δx would not have been equal to $\overline{PP'}$; we should have had:

$$\frac{\Delta x}{360} = \frac{\overline{PP'}}{2\pi}, \quad \text{or} \quad \Delta x = \frac{180}{\pi} \overline{PP'}.$$

Hence (3) would have read: $\frac{\Delta y}{\Delta x} = \frac{\pi}{180} \cdot \frac{QP'}{\overline{PP'}}$,

and thus the formula of differentiation would have become :

$$D_x \sin x = \frac{\pi}{180} \cos x.$$

The saving of labor and the gain in simplicity in not being obliged to multiply by this constant each time we differentiate is enormous.

2. Differentiation of $\cos x$, $\tan x$, etc. To differentiate $\cos x$ we may set

$$x = \frac{\pi}{2} - y.$$

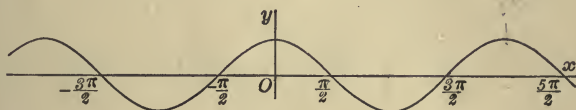

FIG. 19

Then $\cos x = \sin y$,

$$\begin{aligned} D_x \cos x &= D_x \sin y \\ &= D_y \sin y D_x y = -\cos y, \\ (7) \therefore D_x \cos x &= -\sin x. \end{aligned}$$

To differentiate $\tan x$ write

$$\tan x = \frac{\sin x}{\cos x}.$$

Then

$$\begin{aligned} D_x \tan x &= \frac{\cos^2 x - \sin x (-\sin x)}{\cos^2 x} \\ &= \frac{1}{\cos^2 x}, \end{aligned}$$

$$(8) \therefore D_x \tan x = \sec^2 x.$$

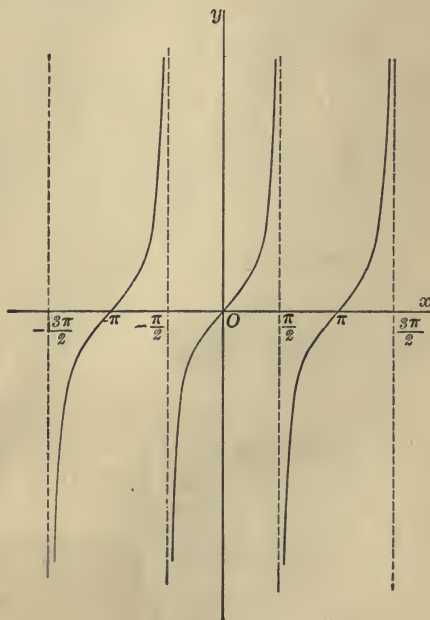

FIG. 20

EXERCISES

1. Show that

$$(a) \quad D_x \cot x = -\operatorname{csc}^2 x;$$

$$(b) \quad D_x \sec x = \sin x \sec^2 x;$$

$$(c) \quad D_x \operatorname{csc} x = -\cos x \operatorname{csc}^2 x;$$

$$(d)^* \quad D_x \operatorname{vers} x = \sin x.$$

Differentiate the following functions :

2. $\sin 2x.$

6. $1 - \sin x.$

10. $\cos^3 x.$

3. $\cos 2x.$

7. $x - \tan x.$

11. $\sec^2 x.$

4. $\tan \frac{x}{2}.$

8. $x \sin x.$

12. $\sin x \cos x.$

5. $\frac{\sin x}{a + b \cos x}.$

9. $\frac{1}{a \sin x + b \cos x}.$

13. $\frac{1 - \cos x}{1 + \cos x}.$

14. Prove that

$$\lim_{\alpha \rightarrow 0} \frac{1 - \cos \alpha}{\alpha} = 0,$$

first, by considering the representation of numerator and denominator by lines in Fig. 17; secondly, by a trigonometric reduction, expressing $1 - \cos \alpha$ in terms of the half-angle, $\alpha/2$.

3. Inverse Functions. Let

$$y = f(x)$$

be a given function of x and let us solve for x as a function of y :

$$x = \phi(y).$$

Then $\phi(y)$ is called the *inverse* of the function $f(x)$. The graph of the former function serves as the graph of the latter, provided in the latter case we take y as the independent, x as the dependent variable. In order to obtain the graph of the

* The *versed sine* and the *coversed sine* are defined as follows :

$$\operatorname{vers} x = 1 - \cos x,$$

$$\operatorname{covers} x = 1 - \sin x.$$

inverse function with x as the independent variable, transform the x, y plane, and with it the above graph, as follows: let

$$x = y', \quad y = x'.$$

This is equivalent to rotating the plane through 180° about the bisector of the angle made by the positive coordinate axes. In other words, it amounts to a *reflection* of the plane in that bisector. We have met an example of inverse functions in the radical, $x^{1/2}$, Chap. II, § 8.

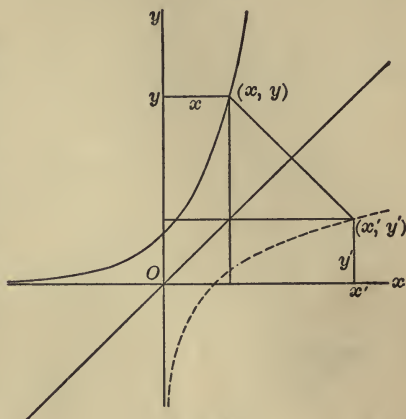

FIG. 21

If, as x increases, y steadily increases (or if y steadily decreases), the inverse function will obviously be single-valued. In this case the derivative of the inverse function is obtained from the definition:

$$y = \phi(x) \quad \text{if} \quad x = f(y),$$

and the relation:

$$\frac{\Delta y}{\Delta x} = \frac{1}{\frac{\Delta x}{\Delta y}};$$

hence
$$\lim_{\Delta x \neq 0} \frac{\Delta y}{\Delta x} = \lim_{\Delta y \neq 0} \frac{1}{\frac{\Delta x}{\Delta y}}, \quad D_x y = \frac{1}{D_y x},$$

provided $D_y x \neq 0$.

4. The Inverse Trigonometric Functions. (a) $\sin^{-1}x$. The inverse of the function

$$(1) \quad y = \sin x$$

is obtained as explained in § 3 by solving this equation for x as a function of y , and is written:

$$(1') \quad x = \sin^{-1}y,$$

read "the antisine of y ." In order to obtain the graph of the function

$$(2) \quad y = \sin^{-1} x$$

we have, then, to reflect the graph of (1) in the bisector of the angle made by the positive coordinate axes. We are thus led

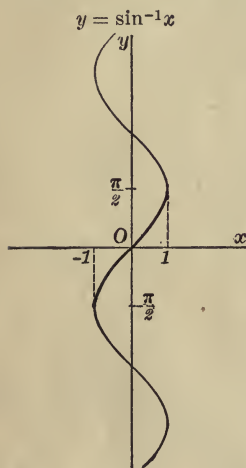

FIG. 22

to a multiple-valued function, since the line $x = x' (-1 \leq x' \leq 1)$ cuts the graph in more than one point, — in fact, in an infinite number of points. For most purposes of the Calculus, however, it is allowable and advisable to pick out just one value of the function (2), most simply the value that lies between $-\pi/2$ and $+\pi/2$, and to understand by $\sin^{-1} x$ the *single-valued* function thus obtained. Its graph is the portion of the curve in Fig. 22 that is marked by a heavy line. This shall be our convention, then, in the future unless the contrary is explicitly stated, and thus

$$(3) \quad y = \sin^{-1} x$$

is equivalent to the relations:

$$(3') \quad x = \sin y, \quad -\frac{\pi}{2} \leq y \leq \frac{\pi}{2}.$$

In particular,

$$\sin^{-1} 0 = 0, \quad \sin^{-1} 1 = \frac{\pi}{2}, \quad \sin^{-1}(-1) = -\frac{\pi}{2}.$$

In order to differentiate the function (3) write it in the implicit form (3') and differentiate:*

$$D_x x = D_x \sin y = D_y \sin y D_x y$$

or

$$1 = \cos y D_x y, \quad D_x y = \frac{1}{\cos y}.$$

* It was shown in § 3 generally that, whenever a function has a derivative $\neq 0$, its inverse function also has a derivative, and hence we are

Now $\sin^2 y + \cos^2 y = 1$ or $\cos^2 y = 1 - x^2$,

and since, for values of y restricted as by (3') to lie between $-\pi/2$ and $+\pi/2$, $\cos y \geq 0$, we have

$$\cos y = \sqrt{1 - x^2},$$

and so finally: *

$$(4) \quad D_x \sin^{-1} x = \frac{1}{\sqrt{1 - x^2}}.$$

(b) $\cos^{-1} x$. The treatment here is precisely similar. We define:

$$(5) \quad y = \cos^{-1} x \quad \text{if} \quad x = \cos y,$$

and we make the inverse function single-valued by choosing that value of y which satisfies the relation:

$$(6) \quad 0 \leq y \leq \pi.$$

In particular

$$\cos^{-1} 1 = 0, \quad \cos^{-1} 0 = \frac{\pi}{2}, \quad \cos^{-1}(-1) = \pi.$$

To differentiate $\cos^{-1} x$ use the implicit form:

$$D_x x = D_x \cos y = D_y \cos y D_x y,$$

$$1 = -\sin y D_x y,$$

$$(7) \quad D_x \cos^{-1} x = -\frac{1}{\sqrt{1 - x^2}}.$$

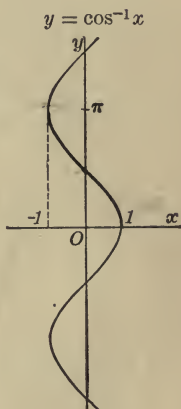

FIG. 23

The functions $\sin^{-1} x$ and $\cos^{-1} x$, when restricted by (3') and (6) to be single-valued, are connected by the relation:

$$(8) \quad \cos^{-1} x = \frac{\pi}{2} - \sin^{-1} x.$$

Hence we could have obtained (7) directly by differentiating (8).

not assuming the existence of a derivative and merely computing it. All the conditions of Theorem V in Chap. II here employed are actually fulfilled, and thus our proof is complete.

* Geometrically the slope of the portion of the graph in question is always positive, and so we must use the positive square root of $1 - x^2$.

(c) $\tan^{-1}x$. Here

$$y = \tan^{-1}x \quad \text{if} \quad x = \tan y,$$

and we make the inverse function single-valued by picking out that value y for which

$$(10) \quad -\frac{\pi}{2} < y < \frac{\pi}{2}.$$

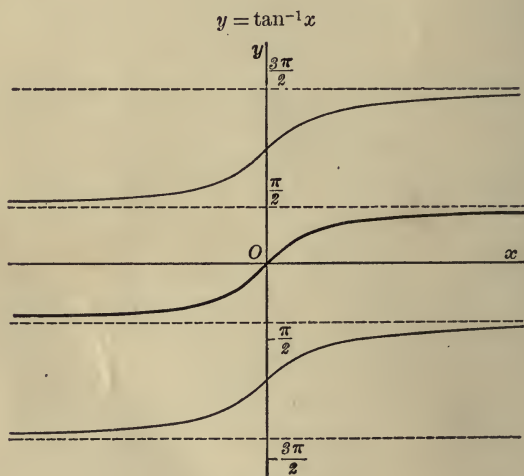

FIG 24.

To differentiate $\tan^{-1}x$ use the implicit form :

$$D_x x = D_x \tan y = D_y \tan y D_x y,$$

$$1 = \sec^2 y D_x y,$$

$$(11) \quad D_x \tan^{-1}x = \frac{1}{1+x^2}.$$

The other inverse trigonometric functions are treated in a similar manner. The usual notation on the Continent for $\sin^{-1}x$, $\tan^{-1}x$, etc., is arc sin x , arc tan x , etc.

Corresponding to the addition theorems for the trigonometric functions there are functional relations for the inverse trigonometric functions, such for example as, for $\tan^{-1}x$:

$$\tan^{-1}u + \tan^{-1}v = \tan^{-1} \frac{u+v}{1-uv}.$$

If these relations are used, the above definitions of $\sin^{-1}x$, $\cos^{-1}x$, $\tan^{-1}x$, by which these functions are made single-valued, must be abandoned. For this reason it is better, for the present, at least, to abandon these relations and to keep these important functions single-valued.

EXERCISES

1. Show that

(a) $\cot^{-1}x = \tan^{-1} \frac{1}{x};$

(b) $\cot^{-1}x = \frac{\pi}{2} - \tan^{-1}x.$

2. Prove the following formulas:

(a) $D_x \cot^{-1}x = -\frac{1}{1+x^2};$

(b) $D_x \sec^{-1}x = \frac{1}{x\sqrt{x^2-1}},$ if $0 < \sec^{-1}x < \pi;$

(c) $D_x \csc^{-1}x = \frac{-1}{x\sqrt{x^2-1}},$ if $-\frac{\pi}{2} < \csc^{-1}x < \frac{\pi}{2};$

(d) $D_x \text{vers}^{-1}x = \frac{1}{\sqrt{2x-x^2}},$ if $0 \leq \text{vers}^{-1}x \leq \pi.$

Plot the graph of the function roughly in each case.

3. Differentiate

(a) $\sin^{-1} \frac{x}{2};$ (b) $\tan^{-1} \frac{x}{a};$ (c) $\cos^{-1} 2x.$

5. Logarithms and Exponentials. In Chap. II, § 8, we have studied the function

$$y = x^n$$

for commensurable values of n , x being the independent variable. Suppose we cut the family of curves of Fig. 3 by a straight line parallel to the axis of ordinates:

$$x = a, \quad a > 1.$$

The ordinate of any one of the points of intersection:

$$(1) \quad y = a^n,$$

is determined as soon as the value of n has been assigned, and is thus a function of n . From the theorem of p. 32 we know that, when n increases, y increases. Moreover, y is always positive; it increases without limit when $n = +\infty$, and it approaches 0 when $n = -\infty$.

As yet the function (1) has been defined only for commensurable values of n . What value shall it have when, for example, $n = \sqrt{2}$? If we allow n , passing through rational values,

to approach $\sqrt{2}$ as its limit, it turns out that a^n approaches a definite limit. We define $a^{\sqrt{2}}$ as this limit:

$$\lim_{n \rightarrow \sqrt{2}} a^n = a^{\sqrt{2}}.$$

And similarly for every other incommensurable value of the exponent. The function thus obtained:

$$(2) \quad y = a^x,$$

is continuous. Its graph for the special

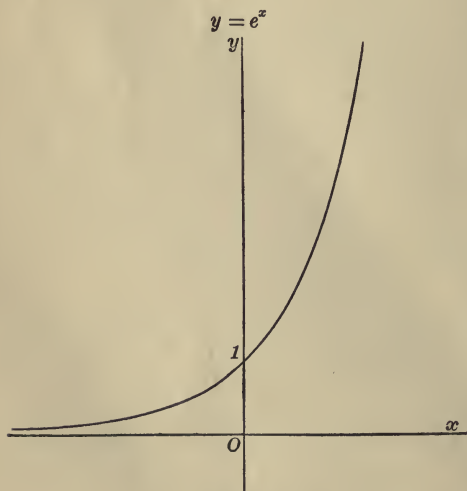

FIG. 25

value $a = 2.72$ is shown in Fig. 25. For a proof of the foregoing statements cf. the Appendix.

The chief properties of the exponential function thus defined are expressed by the equations

$$(I) \quad a^{u+v} = a^u a^v,$$

called the *Addition Theorem*; and

$$(II) \quad (a^u)^v = a^{uv}.$$

The inverse of the exponential function is the *logarithm*:

$$(3) \quad y = \log_a x \quad \text{if} \quad x = a^y.$$

It is single-valued and continuous for all positive values of x . Moreover,

$$\log_a 1 = 0, \quad \log_a a = 1, \quad \log_a 0 = -\infty, \quad \log_a (+\infty) = +\infty.$$

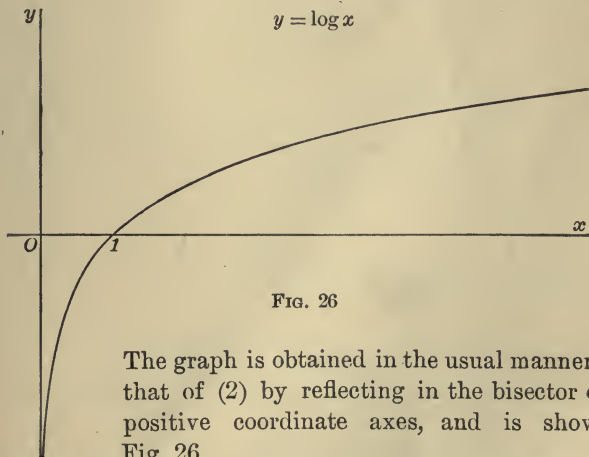

FIG. 26

The graph is obtained in the usual manner from that of (2) by reflecting in the bisector of the positive coordinate axes, and is shown in Fig. 26.

The chief properties of logarithms follow from (I) and (II):

$$(A) \quad \log_a x + \log_a y = \log_a xy;$$

$$(B) \quad \log_a x^n = n \log_a x.$$

The proof of (A) is as follows. Let

$$u = \log_a x, \quad \text{whence } x = a^u;$$

$$v = \log_a y, \quad \text{“ } y = a^v.$$

Then (I) becomes :

$$a^{u+v} = xy, \quad \text{whence } u + v = \log_a xy,$$

$$\text{or} \quad \log_a x + \log_a y = \log_a xy, \quad \text{q. e. d.}$$

To prove (B) write (II) in the form

$$(a^u)^n = a^{nu}$$

and substitute for a^u its value x :

$$x^n = a^{nu}, \quad \text{whence } nu = \log_a x^n,$$

$$\text{or} \quad \log_a x^n = n \log_a x, \quad \text{q. e. d.}$$

A third relation is of importance when we have to change from one base to another. It is:

$$(C) \quad \log_a x = \frac{\log_b x}{\log_b a}.$$

It is easily remembered because of its formal analogy with the formula (V'') of Chap. II, which, when the variables are denoted by a , b , and x , becomes:

$$D_a x = \frac{D_b x}{D_b a}.$$

The proof is as follows. Let

$$(\alpha) \quad u = \log_a x, \quad \text{whence } x = a^u;$$

$$(\beta) \quad v = \log_b x, \quad \text{“ } x = b^v;$$

$$(\gamma) \quad C = \log_b a, \quad \text{“ } a = b^C.$$

We wish to prove that

$$u = \frac{v}{C}.$$

From (γ) follows that

$$b = a^{\frac{1}{C}}.$$

Substituting this value of b in (β) we get:

$$x = a^{\frac{v}{\sigma}}.$$

Substituting this value of x in (α) we get:

$$a^u = a^{\frac{v}{\sigma}}.$$

And now it merely remains to take the logarithm of each side.

In particular, if we set $x = b$, (C) becomes:

$$(4) \quad \log_a b = \frac{1}{\log_b a}.$$

The following identity, which is often useful, is obtained by replacing y in the second equation of (3) by its value from the first equation:

$$(5) \quad x = a^{\log_a x}$$

Thus

$$(6) \quad x^n = a^{n \log_a x}$$

We have assumed hitherto that $a > 1$. If $0 < a < 1$, the graph of (2), Fig. 25, must be reflected in the axis of ordinates, and the graph of (3), Fig. 26, in the axis of abscissas.

EXERCISES

1. Show that

$$(a) \quad \log_a \frac{1}{x} = -\log_a x.$$

$$(b) \quad \log_a \frac{P}{Q} = \log_a P - \log_a Q.$$

$$(c) \quad \log_b \sqrt{1+a^2} = \frac{1}{2} \log_b (1+a^2).$$

$$(d) \quad \log_a (x^2 - y^2) = \log_a (x+y) + \log_a (x-y).$$

$$(e) \quad \log_a (x+h) - \log_a x = \log_a \left(1 + \frac{h}{x}\right).$$

2. Simplify the following expressions:

$$(2^p)^2, \quad \sqrt[3]{a^x}, \quad (2^p)^p, \quad \sqrt[n]{a^{n^2+n}}, \quad \frac{1}{a^{-z}}, \quad \frac{a^{m+n}}{a^{m-n}}.$$

3. Solve the equation :

$$\frac{a^x - a^{-x}}{a^x + a^{-x}} = y$$

for x in terms of y .

4. Show that

$$\frac{\log_a(1+h)}{h} = \log_a[(1+h)^{\frac{1}{h}}].$$

5. Are $(a)^{x^x}$ and $(a^x)^x$ the same thing?

6. If $b^x = c$,

show that

$$x \log_a b = \log_a c.$$

6. Differentiation of $\log x$. To differentiate the function

$$y = \log_a x$$

we have to form the difference-quotient :

$$(7) \quad \frac{\Delta y}{\Delta x} = \frac{\log_a(x_0 + \Delta x) - \log_a x_0}{\Delta x} = \frac{\log_a\left(1 + \frac{\Delta x}{x_0}\right)}{\Delta x}$$

and see what limit it approaches when Δx approaches 0. If we set

$$\frac{x_0}{\Delta x} = \mu,$$

we can write this last expression in the form :

$$(8) \quad \frac{1}{x_0} \cdot \frac{x_0}{\Delta x} \log_a\left(1 + \frac{\Delta x}{x_0}\right) = \frac{1}{x_0} \mu \log_a\left(1 + \frac{1}{\mu}\right) = \frac{1}{x_0} \log_a\left[\left(1 + \frac{1}{\mu}\right)^\mu\right].$$

When Δx approaches 0, μ becomes infinite, and the question is: What is the value of the limit :

$$\lim_{\mu=\infty} \left(1 + \frac{1}{\mu}\right)^\mu ?$$

First, let μ become infinite passing through only positive integral values :

$$\mu = n, \quad n = 1, 2, 3, \dots$$

If we write

$$\phi(\mu) = \left(1 + \frac{1}{\mu}\right)^\mu,$$

we get by direct computation :

$$\phi(1) = 2,$$

$$\phi(2) = 2.25,$$

$$\phi(3) = 2.37,$$

$$\phi(10) = 2.59,$$

$$\phi(100) = 2.70,$$

$$\phi(1000) = 2.72,$$

$$\phi(10,000) = 2.72.$$

Hence we see that, as n increases, $\phi(n)$ increases, but does not appear to mount above a number somewhat less than 3. We can show this to be the case no matter how large n . By the Binomial Theorem :

$$(a + b)^n = a^n + na^{n-1}b + \frac{n(n-1)}{1 \cdot 2}a^{n-2}b^2 + \dots$$

we have :

$$\begin{aligned} \phi(n) &= \left(1 + \frac{1}{n}\right)^n = 1 + n\left(\frac{1}{n}\right) + \frac{n(n-1)}{1 \cdot 2}\left(\frac{1}{n}\right)^2 \\ &\quad + \frac{n(n-1)(n-2)}{1 \cdot 2 \cdot 3}\left(\frac{1}{n}\right)^3 + \dots \text{ to } n + 1 \text{ terms} \\ &= 1 + 1 + \frac{1 - \frac{1}{n}}{1 \cdot 2} + \frac{\left(1 - \frac{1}{n}\right)\left(1 - \frac{2}{n}\right)}{1 \cdot 2 \cdot 3} + \dots \end{aligned}$$

These terms are all positive and each increases when n increases. Moreover, when n increases, additional positive terms present themselves. And so, for both reasons, $\phi(n)$ increases :

$$\phi(n + 1) > \phi(n).$$

Secondly, $\phi(n)$ is always less than 3. For, the above terms after the first two are less than the terms of the series:

$$1 + 1 + \frac{1}{2} + \frac{1}{2^2} + \cdots + \frac{1}{2^{n-1}}.$$

Recalling the formula for the sum of the first n terms of a geometric progression, Chap. I, § 1, and setting $a=1$, $r=\frac{1}{2}$, we get:

$$1 + \frac{1}{2} + \frac{1}{2^2} + \cdots + \frac{1}{2^{n-1}} = \frac{1 - (\frac{1}{2})^n}{1 - \frac{1}{2}} = 2 - \frac{1}{2^{n-1}},$$

and so:
$$\phi(n) < 3 - \frac{1}{2^{n-1}} < 3.$$

Now if we have a function of the positive integer n which always increases as n increases, but never exceeds a certain



FIG. 27

fixed number, A , it must approach a limit not greater than A , when $n = \infty$ (Fundamental Principle for the existence of a limit, Chap. XII, § 2). Hence $\phi(n)$ approaches a limit whose value, e , is not greater than 3:

$$(9) \quad \lim_{n \rightarrow \infty} \left(1 + \frac{1}{n}\right)^n = e.$$

We shall see later that

$$e = 2.718 \dots$$

μ irrational and negative. We can now show that, when μ becomes positively infinite, *varying continuously*, i.e. passing through all positive values, $\phi(\mu)$ still approaches e as its limit.

Let

$$n < \mu < n + 1,$$

where n is an integer; then

$$1 + \frac{1}{n+1} < 1 + \frac{1}{\mu} < 1 + \frac{1}{n},$$

$$\left(1 + \frac{1}{n+1}\right)^\mu < \left(1 + \frac{1}{\mu}\right)^\mu < \left(1 + \frac{1}{n}\right)^\mu.$$

We shall only strengthen this inequality if in the left-hand member we replace μ by n , in the right-hand member, by $n + 1$. Hence

$$\frac{\left(1 + \frac{1}{n+1}\right)^{n+1}}{1 + \frac{1}{n+1}} < \phi(\mu) < \left(1 + \frac{1}{n}\right)^n \left(1 + \frac{1}{n}\right).$$

As μ , and with it n , becomes infinite, each extreme member of this double inequality approaches e as its limit, hence the mean member must likewise approach e and

$$\lim_{\mu \rightarrow +\infty} \phi(\mu) = e.$$

Finally, let μ be negative, $\mu = -r$. Then

$$\begin{aligned} \left(1 + \frac{1}{\mu}\right)^\mu &= \left(1 - \frac{1}{r}\right)^{-r} = \left(\frac{r-1}{r}\right)^{-r} = \left(\frac{r}{r-1}\right)^r = \left(1 + \frac{1}{r-1}\right)^r \\ &= \left(1 + \frac{1}{r-1}\right)^{r-1} \left(1 + \frac{1}{r-1}\right). \end{aligned}$$

When $\mu = -\infty$, $r = +\infty$, and

$$\lim_{\mu \rightarrow -\infty} \phi(\mu) = e.$$

Returning now to equations (7) and (8) and remembering that $\log_a x$ is a continuous function, we see that

$$\begin{aligned} \lim_{\Delta x \neq 0} \frac{\Delta y}{\Delta x} &= \lim_{\mu = \pm\infty} \left[\frac{1}{x_0} \log \left(1 + \frac{1}{\mu}\right)^\mu \right] = \frac{1}{x_0} \log \left[\lim_{\mu = \pm\infty} \left(1 + \frac{1}{\mu}\right)^\mu \right] \\ &= \frac{1}{x_0} \log_a e, \end{aligned}$$

or, dropping the subscript, we have:

$$(10) \quad D_x \log_a x = \frac{\log_a e}{x}.$$

The base a of the system of logarithms which we will use is at our disposal. We may choose it so that the constant factor

$$\log_a e = 1,$$

namely, by taking e as the base: $a = e$. Thus (10) becomes:

$$(11) \quad D_x \log_e x = \frac{1}{x}.$$

This base, e , is called the *natural base*, and logarithms taken with e as the base are called *natural* or *Napierian logarithms*, in distinction from *denary* or *Briggs's logarithms*, for which the base is 10. Natural logarithms are used in the Calculus because of the gain in simplicity in the formulas of differentiation and integration, — a gain precisely analogous to that in the differentiation of the trigonometric functions when the angle is measured in radians.

It is customary in the Calculus not to write the subscript e and to understand by $\log x$ the natural logarithm of x , the denary logarithm being expressed as $\log_{10} x$.

7. The Compound Interest Law. The limit (9) of § 6 presents itself in a variety of problems, typical for which is that of finding how much interest a given sum of money would bear if the interest were compounded continuously, so that there is no loss whatever. For example, \$1000, put at interest at 6%, amounts in a year to \$1060, if the interest is not compounded at all. If it is compounded every six months, we have

$$\$1000 \left(1 + \frac{.06}{2} \right)$$

as the amount at the end of the first six months, and this must be multiplied by $\left(1 + \frac{.06}{2} \right)$ to yield the amount at the end of the second six months, the final amount thus being

$$\$1000 \left(1 + \frac{.06}{2} \right)^2.$$

It is readily seen that if the interest is compounded n times in a year, the principal and interest at the end of the year will amount to

$$1000 \left(1 + \frac{.06}{n} \right)^n$$

dollars, and we wish to find the limit of this expression when $n = \infty$. To do so, write it in the form :

$$1000 \left[\left(1 + \frac{.06}{n} \right)^{\frac{n}{.06}} \right]^{.06}$$

and set $n/.06 = \mu$. The bracket thus becomes

$$\phi(\mu) = \left(1 + \frac{1}{\mu} \right)^\mu,$$

and its limit is e . Hence the desired result is

$$1000e^{.06} = 1061.84.*$$

EXERCISE

If \$1000 is put at interest at 4% compare the amounts of principal and interest at the end of 10 years, (a) when the interest is compounded semi-annually, and (b) when it is compounded continuously. *Ans.* A difference of \$5.88.

8. Differentiation of e^x, a^x . Since a^x and $\log_a x$ are inverse functions, we have:

$$(12) \quad y = a^x \quad \text{if} \quad x = \log_a y.$$

In particular:

$$(13) \quad y = e^x \quad \text{if} \quad x = \log y.$$

Differentiating this last equation with respect to x , we obtain:

$$(14) \quad \begin{aligned} D_x x = D_x \log y = D_y \log y D_x y, & \quad 1 = \frac{1}{y} D_x y, \\ \therefore D_x e^x = e^x. & \end{aligned}$$

* The actual computation here is expeditiously done by means of series; see the chapter on Taylor's Theorem.

If we proceed with (12) in a similar manner, we get as our first result:

$$1 = \frac{\log_a e}{y} D_x y.$$

By (4) in § 5:

$$\log_a e = \frac{1}{\log_e a}.$$

$$(15) \quad \therefore D_x a^x = a^x \log a.$$

Differentiation of x^n , n irrational. Formula (12) of Chap. II can now be shown to hold when n is irrational. Since by § 5, (6):

$$x^n = e^{n \log x},$$

if we set

$$z = n \log x,$$

we have $D_x x^n = D_x e^z = D_z e^z \cdot D_x z = e^z n \frac{1}{x} = n x^{n-1}$, q. e. d.

We are now in a position to differentiate any of the elementary functions without evaluating new limits, for any such differentiations can be reduced, by the aid of Theorems I-V of Chap. II, to special formulas already in our possession. An important aid, however, in the technique of differentiation is furnished by the method of differentials, which we will consider in the next chapter, and so we shall postpone the drill work on this chapter till that method has been taken up.

EXERCISES

Differentiate the following functions:

$$1. \quad y = \log_{10} x. \quad \text{Ans. } D_x y = \frac{.4343}{x}.$$

$$2. \quad y = 10^x. \quad \text{Ans. } D_x y = 2.303 \times 10^x.$$

$$3. \quad y = \log \sin x. \quad 4. \quad y = e^{\cos x}.$$

$$5. \quad y = \log \tan \left(\frac{x}{2} + \frac{\pi}{4} \right). \quad \text{Ans. } D_x y = \frac{1}{\cos x}.$$

Important.

CHAPTER V

INFINITESIMALS AND DIFFERENTIALS

1. **Infinitesimals.** An *infinitesimal* is a variable which it is usually desirable to consider only for values numerically small and which, when the formulation of the problem in hand has progressed to a certain stage, is allowed to approach 0 as its limit. Thus in the problem of differentiation Δx and Δy are infinitesimals; for we allow Δx to approach 0 as its limit and then Δy in general also approaches 0. Again, in Chap. IV, we had to do with $\lim_{\alpha \rightarrow 0} \frac{\sin \alpha}{\alpha}$. Here α and $\sin \alpha$ are infinitesimals.

Further examples of infinitesimals are furnished by the following magnitudes of Fig. 28:

- (1) $\alpha = \overset{\frown}{AP}$, $\beta = AQ = \tan \alpha$,
 $\gamma = MA = 1 - \cos \alpha$, $\delta = AN$,
 $\epsilon = PQ$, $\zeta = AQ + QP$, etc.

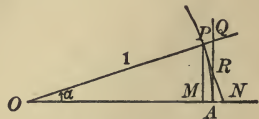

FIG. 28.

That infinitesimal which is chosen as the independent variable is called the *principal infinitesimal*.

Two infinitesimals, α and β , are said to be of the *same order* if their ratio approaches a limit not 0 when the principal infinitesimal approaches 0:

$$\lim \frac{\beta}{\alpha} = K \neq 0.$$

If their ratio approaches 0 as its limit, β is said to be of *higher order* than α , and if it becomes infinite, β is of *lower order*.

Thus if $\beta = \tan \alpha$,

$$\frac{\beta}{\alpha} = \frac{\tan \alpha}{\alpha} = \frac{1}{\cos \alpha} \frac{\sin \alpha}{\alpha}$$

and $\lim_{\alpha \neq 0} \frac{\beta}{\alpha} = 1 \neq 0$.

Hence $\tan \alpha$ is of the same order as α .

Again, if $\gamma = 1 - \cos \alpha$,

$$\frac{\gamma}{\alpha} = \frac{1 - \cos \alpha}{\alpha} = \frac{2 \sin^2 \frac{\alpha}{2}}{\alpha} = \sin \frac{\alpha}{2} \frac{\sin \frac{\alpha}{2}}{\frac{\alpha}{2}}$$

Hence $\lim_{\alpha \neq 0} \frac{\gamma}{\alpha} = 0$

and $1 - \cos \alpha$ is of higher order than α .

An example of an infinitesimal of lower order is $\sqrt{\alpha}$. For

$$\frac{\sqrt{\alpha}}{\alpha} = \frac{1}{\sqrt{\alpha}} \quad \text{and} \quad \lim_{\alpha \neq 0} \frac{1}{\sqrt{\alpha}} = \infty$$

(read: "1/ $\sqrt{\alpha}$ becomes infinite when α approaches 0").

It is readily seen that, if β and γ are infinitesimals of the same order, or if γ is of higher order than β , and if furthermore β is of higher order than α , then γ is also of higher order than α . For, since

$$\lim_{\alpha \neq 0} \frac{\gamma}{\beta} = K,$$

we have: $\frac{\gamma}{\beta} = K + \epsilon$, $\gamma = K\beta + \epsilon\beta$,

where ϵ is infinitesimal. Hence

$$\frac{\gamma}{\alpha} = \frac{\beta}{\alpha} (K + \epsilon),$$

and since $\lim \beta/\alpha = 0$ by hypothesis, we see that $\lim \gamma/\alpha = 0$.

Similarly, if β and γ are of the same order, or if γ is of lower order than β , and if furthermore β is of lower order than α , then γ is also of lower order than α .

An infinitesimal β is said to be of the n -th order if β/α^n approaches a limit not 0, α being the principal infinitesimal:

$$\lim_{\alpha \rightarrow 0} \frac{\beta}{\alpha^n} = K \neq 0.$$

For example, if α is the principal infinitesimal, $\sin \alpha$ and $\tan \alpha$ are of the first order, $\sqrt{\alpha}$ is of order $\frac{1}{2}$, α^n is of order n , and $1 - \cos \alpha$ can be shown to be of order 2. For

$$\frac{1 - \cos \alpha}{\alpha^2} = \frac{2 \sin^2 \frac{\alpha}{2}}{\alpha^2} = \frac{1}{2} \left[\frac{\sin \frac{\alpha}{2}}{\frac{\alpha}{2}} \right]^2,$$

and
$$\lim_{\alpha \rightarrow 0} \frac{1 - \cos \alpha}{\alpha^2} = \frac{1}{2}.$$

THEOREM. *If two infinitesimals α and β differ from each other by an infinitesimal of higher order than either, then*

$$\lim \frac{\beta}{\alpha} = 1.$$

And conversely: If $\lim \beta/\alpha = 1$, then α and β differ from each other by an infinitesimal of higher order than either:

$$\beta - \alpha = \epsilon, \quad \lim \frac{\epsilon}{\alpha} = 0.$$

First, our hypothesis is that, if we write:

$$\beta - \alpha = \epsilon, \quad \text{then} \quad \lim \frac{\epsilon}{\alpha} = 0.$$

Dividing through by α we have:

$$\frac{\beta}{\alpha} = 1 + \frac{\epsilon}{\alpha}.$$

Hence
$$\lim \frac{\beta}{\alpha} = \lim \left(1 + \frac{\epsilon}{\alpha} \right) = 1, \quad \text{q. e. d.}$$

To prove the converse, write

$$\frac{\beta}{\alpha} = 1 + \eta.$$

Then η is infinitesimal. Multiplying up we have:

$$\beta = \alpha + \eta\alpha.$$

The difference, $\beta - \alpha = \eta\alpha = \epsilon$, is evidently an infinitesimal of higher order than α and hence also than β .

DEFINITION. If α is the principal infinitesimal and if

$$\lim_{\alpha \neq 0} \frac{\beta}{\alpha} = K,$$

so that, when we write

$$\frac{\beta}{\alpha} = K + \epsilon,$$

we have

$$\beta = K\alpha + \epsilon\alpha,$$

then the term $K\alpha$ is called the *principal part* of β .

EXERCISES

1. Show that $\alpha - 2\alpha^2$ and $3\alpha + \alpha^3$ are infinitesimals of the same order.
2. Show that $\alpha - \sin \alpha$ is of higher order than α .
3. Show that $\alpha \sin \alpha$ is an infinitesimal of the second order.
4. In Fig. 28 show that PQ and MA are infinitesimals of the same order.
5. Determine the order of AR , referred to α .
6. Show that AN is of higher order than RQ .
7. Show that AQ and MP are of the same order.
8. Show that PQ is of the second order, referred to α .
9. Determine the order of each of the following infinitesimals:

$$(a) \alpha + \sin \alpha; \quad (b) \sqrt{\sin \alpha}; \quad (c) \sqrt[3]{1 - \cos \alpha}.$$

10. Show that the sum of two positive infinitesimals, each of the first order, is always an infinitesimal of the first order, and that the difference is never of lower order. Cite an example to show that the difference may be of higher order.

11. Determine the principal part of each of the infinitesimals in the text numbered (1).

12. If two infinitesimals have the same principal part, show that they differ from each other by a small percentage of the value of either, and that this percentage is infinitesimal, provided that their principal part is not 0.

2. Fundamental Theorem. There are two theorems that are fundamental relating to the replacement of infinitesimals by other infinitesimals that differ from them respectively by infinitesimals of higher order. One is the theorem of this paragraph; the other is Duhamel's Theorem of Chap. IX, § 6.

THEOREM. *In taking the limit of the ratio of two infinitesimals, each infinitesimal may be replaced by another one which differs from it by an infinitesimal of higher order:*

$$\text{if} \quad \lim \frac{\beta'}{\beta} = 1 \quad \text{and} \quad \lim \frac{\gamma'}{\gamma} = 1, \quad \lim \frac{\beta}{\gamma} = \lim \frac{\beta'}{\gamma'}$$

For, since

$$\frac{\beta'}{\beta} = 1 + \epsilon \quad \text{or} \quad \beta' = \beta(1 + \epsilon)$$

$$\text{and} \quad \frac{\gamma'}{\gamma} = 1 + \eta \quad \text{or} \quad \gamma' = \gamma(1 + \eta),$$

where ϵ and η are infinitesimals, we have:

$$\frac{\beta'}{\gamma'} = \frac{\beta}{\gamma} \frac{1 + \epsilon}{1 + \eta}$$

Hence

$$\lim \frac{\beta'}{\gamma'} = \left(\lim \frac{\beta}{\gamma} \right) \left(\lim \frac{1 + \epsilon}{1 + \eta} \right) = \lim \frac{\beta}{\gamma}, \quad \text{q. e. d.}$$

3. Tangents in Polar Coordinates. Let

$$r = f(\theta)$$

be the equation of a curve in polar coordinates. We wish to find the direction of its tangent. The direction will be known if we can determine the angle ψ between the radius vector produced and the tangent. Let P , with the coordinates

(r_0, θ_0) , be an arbitrary

point of the curve and

$P' : (r_0 + \Delta r, \theta_0 + \Delta \theta)$

a neighboring point.

Draw the chord PP'

and denote the $\angle OP'P$

by ψ' . Then obviously

$$\lim_{P' \rightarrow P} \psi' = \psi_0.$$

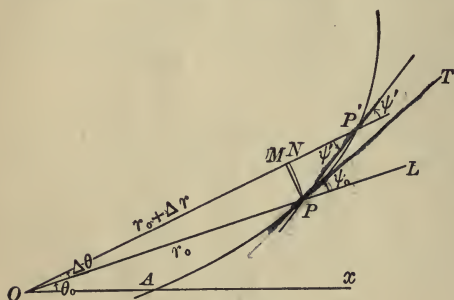

FIG. 29

PM from P on the radius vector OP' and draw an arc PN of a circle with O as centre. The right triangle $MP'P$ is a triangle of reference for the angle ψ' and

$$\tan \psi' = \frac{MP}{P'M}.$$

Hence
$$\tan \psi_0 = \lim_{P' \rightarrow P} \tan \psi' = \lim_{P' \rightarrow P} \frac{MP}{P'M}.$$

In the latter ratio we can, by virtue of the Fundamental Theorem of § 2, replace MP and $P'M$ by more convenient infinitesimals. We observe that

$$MP = r_0 \sin \Delta \theta, \quad \text{hence} \quad \lim_{\Delta \theta \rightarrow 0} \frac{MP}{r_0 \Delta \theta} = 1.$$

Furthermore,

$$P'N = \Delta r, \quad \text{so that} \quad \lim_{\Delta r \rightarrow 0} \frac{P'M}{\Delta r} = 1.$$

Hence we have :

$$\lim_{P' \neq P} \frac{MP}{P'M} = \lim_{\Delta\theta \neq 0} \frac{r_0 \Delta\theta}{\Delta r} = [r D_r \theta]_{\theta=\theta_0},$$

or, dropping the subscripts :

$$(2) \quad \tan \psi = r D_r \theta.$$

Example. The curve

$$(3) \quad r = ae^{\lambda\theta}, \quad a > 0,$$

is a spiral, except when $\lambda = 0$, which coils round the origin infinitely often. Here,

$$D_\theta r = a\lambda e^{\lambda\theta}, \quad D_r \theta = \frac{1}{D_\theta r} = \frac{1}{a\lambda e^{\lambda\theta}}, \quad \tan \psi = \frac{1}{\lambda}, \text{ or } \cot \psi = \lambda.$$

Hence the tangent always makes the same angle, $\cot^{-1} \lambda$, with the radius vector produced. For this reason the curve is called the *equiangular spiral*.

EXERCISES

1. Plot the curve

$$r = \theta,$$

and determine the angle at which it crosses the prime vector when $r = 2\pi$. *Ans.* $\psi = 81^\circ$, nearly.

2. The equation of a parabola referred to its focus as pole is

$$r(1 + \cos \theta) = m.$$

Find the value of ψ when $\theta = 0$ and when $\theta = \pi/2$.

3. The equation of a cardioid is

$$r = a(1 - \cos \theta).$$

Determine ψ .

4. Differentials. Let

$$(1) \quad y = f(x)$$

be a function of x and let $D_x y$ be its derivative :

$$\lim_{\Delta x \neq 0} \frac{\Delta y}{\Delta x} = D_x y.$$

Then
$$\frac{\Delta y}{\Delta x} = D_x y + \epsilon,$$

where ϵ is infinitesimal, and

$$\Delta y = D_x y \Delta x + \epsilon \Delta x.$$

Since x is the independent variable, we may take Δx as the principal infinitesimal, and this last relation represents Δy as the sum of its principal part, $D_x y \Delta x$, and an infinitesimal of higher order, $\epsilon \Delta x$.

DEFINITION. The principal part of the increment Δy of the function (1) is called the *differential* of y and is denoted by dy :

$$(2) \quad dy = D_x y \Delta x.$$

We may, in particular, choose $f(x)$ as the function x . Then (2) becomes:

$$(3) \quad dx = D_x x \Delta x = \Delta x.$$

Thus we see that *the differential of the independent variable, x , is equal to the increment of that variable.* But this is not in general true of the dependent variable, since ϵ does not in general vanish.

By means of (3) equation (2) can be written in the form:

$$(4) \quad dy = D_x y dx.$$

Hence

$$(5) \quad \frac{dy}{dx} = D_x y.$$

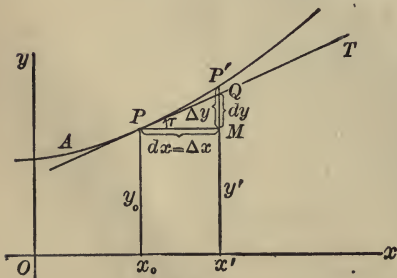

FIG. 30

Geometrically, the increment Δy of the function is represented by the line MP' in Fig. 30, while the differential, dy , is equal to MQ . It is obvious geometrically that the difference between Δy and dy , namely the line QP' , is of higher order than

$\Delta x = PM$. The triangle PMQ is a triangle of reference for τ , and

$$\tan \tau = \frac{dy}{dx}.$$

In the above definition x has been taken as the independent variable, Δx as the principal infinitesimal. The following theorem is fundamental in the theory of differentials.

THEOREM. *The relation (4) :*

$$dy = D_x y dx,$$

is true, even when x and y are both dependent on a third variable, t .

Suppose, namely, that x and y come to us as functions of a third variable, t :

$$(6) \quad x = \phi(t), \quad y = \psi(t),$$

and that, when we eliminate t between these two equations, we obtain the function (1). Then dx and dy have the following values, in accordance with the above definition, since t , not x , is now the independent variable, Δt the principal infinitesimal :

$$dy = D_t y \Delta t, \quad dx = D_t x \Delta t.$$

We wish to prove that

$$dy = D_x y dx.$$

Now by Theorem V of Chap. II :

$$D_t y = D_x y D_t x.$$

Hence, multiplying through by Δt , we get :

$$D_t y \Delta t = D_x y \cdot D_t x \Delta t,$$

or
$$dy = D_x y dx, \quad \text{q. e. d.}$$

With this theorem the explicit use of Theorem V in Chap. II disappears, Formula V of that theorem now taking on the form of an algebraic identity :

$$\frac{du}{dx} = \frac{du}{dy} \frac{dy}{dx}.$$

To this fact is due the chief advantage of differentials in the technique of differentiation.

Differentials of Higher Order. It is possible to introduce differentials of higher order by a similar definition :

$$d^2y = D_x^2y \Delta x^2, \quad d^3y = D_x^3y \Delta x^3, \quad \text{etc.}$$

But inasmuch as a theorem analogous to the above for differentials of the first order does not hold true here, the chief advantage of the differentials of the first order is lost. We shall, therefore, refrain from introducing differentials of higher order and regard the expressions :

$$\frac{d^2y}{dx^2}, \quad \frac{d^3y}{dx^3}, \quad \text{etc.,}$$

not as ratios, but merely as another notation for the derivatives $D_x^2y, D_x^3y, \text{etc.}$ *

Remark. The operator D_x is written in differential form as $\frac{d}{dx}$. Thus

$$\frac{d}{dx} \sqrt{\frac{x}{1-x}} \quad \text{means} \quad D_x \sqrt{\frac{x}{1-x}},$$

and similarly for higher derivatives.

5. Technique of Differentiation. Theorems I–IV of Chap. II, written in terms of differentials, are as follows.

GENERAL FORMULAS OF DIFFERENTIATION

- I. $d(cu) = c du.$
- II. $d(u + v) = du + dv.$
- III. $d(uv) = u dv + v du.$
- IV. $d\left(\frac{u}{v}\right) = \frac{v du - u dv}{v^2}.$

* Differentials of higher order are still used in some branches of mathematics, notably in differential geometry. For a treatment of such differentials cf. Goursat-Hedrick, *Mathematical Analysis*, vol. I, § 14.

Consider, for example, the first :

$$D_x(cu) = c D_x u, \quad \text{i.e.} \quad \frac{d(cu)}{dx} = c \frac{du}{dx},$$

and it remains only to multiply through by dx . — We have already noted the disappearance of Theorem V.

To these are to be added the special formulas of Chapters II and IV. Beside the derivatives that were there worked out *ab initio* it is useful to include in this list a few others.

Impf

SPECIAL FORMULAS OF DIFFERENTIATION

1. $dc = 0.$
2. $dx^n = nx^{n-1} dx.$
3. $d \sin x = \cos x dx.$
4. $d \cos x = -\sin x dx.$
5. $d \tan x = \sec^2 x dx.$
6. $d \log x = \frac{dx}{x}.$
7. $de^x = e^x dx.$
8. $d \sin^{-1} x = \frac{dx}{\sqrt{1-x^2}}.$
9. $d \tan^{-1} x = \frac{dx}{1+x^2}.$

This list is somewhat elastic. Some students will prefer to include the formulas :

10. $d \cos^{-1} x = \frac{-dx}{\sqrt{1-x^2}}.$
11. $d \text{vers}^{-1} x = \frac{dx}{\sqrt{2x-x^2}}.$
12. $d a^x = a^x \log a dx.$

But it is better to err on the side of brevity.

All other functions that occur as combinations of the above, — the so-called *elementary functions*, — can be differentiated by the aid of these two sets of formulas. We will illustrate the use of differentials by some examples.

Example 1. To differentiate

$$y = \sqrt[3]{a^2 - x^2}.$$

Let $z = a^2 - x^2.$

Then $y = z^{\frac{1}{3}},$

$$dy = dz^{\frac{1}{3}} = \frac{1}{3} z^{-\frac{2}{3}} dz = \frac{1}{3} z^{-\frac{2}{3}} (-2x dx),$$

$$\frac{dy}{dx} = -\frac{2}{3} \frac{x}{\sqrt[3]{(a^2 - x^2)^2}}.$$

The work can, however, be abbreviated and rendered more concise by refraining from writing a new letter, z , for the function $a^2 - x^2$:

$$y = (a^2 - x^2)^{\frac{1}{3}},$$

$$dy = \frac{1}{3} (a^2 - x^2)^{-\frac{2}{3}} d(a^2 - x^2) = -\frac{2}{3} x (a^2 - x^2)^{-\frac{2}{3}} dx.$$

Example 2. To differentiate

$$y = \log \sin x.$$

Let $z = \sin x, \quad y = \log z.$

Then $dy = d \log z = \frac{dz}{z} = \frac{\cos x dx}{z},$

or $\frac{dy}{dx} = \frac{\cos x}{\sin x} = \cot x.$

More concisely:

$$dy = d \log \sin x = \frac{d \sin x}{\sin x} = \frac{\cos x dx}{\sin x}.$$

Example 3. To differentiate

$$u = e^{at} \cos bt.$$

$$\begin{aligned}
 du &= \cos bt \, de^{at} + e^{at} \, d \cos bt \\
 &= \cos bt \, e^{at} \, d(at) - e^{at} \sin bt \, d(bt) \\
 &= e^{at} (a \cos bt - b \sin bt) \, dt, \\
 \frac{du}{dt} &= e^{at} (a \cos bt - b \sin bt).
 \end{aligned}$$

When the student has had some practice in the use of differentials he will have no difficulty in suppressing the first two lines of this last differentiation.

Example 4. To differentiate y , where

$$\begin{aligned}
 x^3 - 3xy + y^4 &= 1. \\
 dx^3 - 3d(xy) + dy^4 &= d1, \\
 3x^2 dx - 3x \, dy - 3y \, dx + 4y^3 dy &= 0, \\
 \frac{dy}{dx} &= \frac{3x^2 - 3y}{3x - 4y^3}.
 \end{aligned}$$

The student will avoid errors by noting that when one term of an equation is multiplied by a differential, every term must be so multiplied. Thus such an equation as $dy = x^2 - 3x$ is impossible.

EXERCISES

Employ the method of differentials for performing the following differentiations.

$$1. \quad u = \sqrt{a + bx + cx^2}.$$

$$du = \frac{(b + 2cx) \, dx}{2\sqrt{a + bx + cx^2}}.$$

$$2. \quad y = \frac{1 - 2x + x^2}{x}.$$

$$dy = \frac{x^2 - 1}{x^2} \, dx.$$

$$3. \quad s = \frac{1 - t}{1 + 2t}.$$

$$\frac{ds}{dt} = \frac{-3}{(1 + 2t)^2}.$$

$$4. \quad y = (1 - x)(2 - 3x)(5 - 2x).$$

Work in two ways and check the answers.

5. $r = ae^{\lambda\theta}$.

9. $y = \log \cos x$.

6. $y = e^{-t}(2t^3 + 6t^2 - 3t - 3)$.

10. $y = \log(e^x - e^{-x})$.

7. $u = \sqrt{a^2 - x^2} \sqrt{a - x}$.

11. $y = \frac{\sin x + \cos x}{e^x}$.

8. $y = \log \frac{a+x}{a-x}$.

12. $u = \log \sqrt{1 - \cos x}$.

13. $x = \sqrt{1 + \sin y}$.

$$\frac{dy}{dx} = \frac{2}{\sqrt{2-x^2}}$$

14. $y = \tan^{-1} \frac{2x}{1-x^2}$.

$$\frac{dy}{dx} = \frac{2}{1+x^2}$$

15. $y = \tan^{-1} \frac{2x+1}{3}$.

17. $y = \cot^{-1} \frac{x}{a}$.

16. $y = \sin^{-1}(n \sin x)$.

18. $u = \cos^{-1} \frac{\theta}{2}$.

19. $y = \log \tan \left(\frac{x}{2} + \frac{\pi}{4} \right)$.

$$\frac{dy}{dx} = \sec x$$

20. If $y = xe^{mx}$, find $\frac{d^2y}{dx^2}$ and $\frac{d^3y}{dx^3}$.

21. The same when $y = x^2 e^{mx}$.

22. Differentiate $x^2 a^x$.

$$\frac{d}{dx} x^2 a^x = 2x a^x + x^2 a^x \log a$$

23. Differentiate:

(a) $x10^x$; (b) 10^{x^2} ; (c) $x^n n^x$.

24. Find the slope of the curve $y = \log_{10} x$ at the point $x = 1$, $y = 0$.
Ans. $\tan \tau = .4343$.

25. Obtain the equations of the tangent and normal of the curve $y = 10^x$ at the point where it crosses the axis of ordinates.

To differentiate a function of the form

$$y = [f(x)]^{\phi(x)},$$

begin by taking the logarithm of each side of the equation:

$$\log y = \phi(x) \log f(x).$$

Or, what amounts to the same thing, write

$$f(x) = e^{\log f(x)}, \quad [f(x)]^{\phi(x)} = e^{\phi(x)\log f(x)}.$$

Thus, to differentiate $y = x^x$, write

$$\log y = x \log x \quad \text{or} \quad y = e^{x \log x}.$$

Hence $\frac{dy}{y} = d(x \log x) = \text{etc.}$ or $dy = e^{x \log x} d(x \log x) = \text{etc.}$

$$\frac{dx^x}{dx} = x^x(1 + \log x).$$

Differentiate each of the following functions:

26. $y = x^{\frac{1}{x}}$.

28. $y = (\cos x)^{\tan x}$.

27. $y = x^{\sin x}$.

29. $y = (\sin x)^{\sin x}$.

6. Differential of Arc. Let s denote the length of the arc of the curve $y = f(x)$, measured from a fixed point A , and let Δs denote the length of the arc PP' . Then (see Fig. 30)

$$\overline{PP'}^2 = \Delta x^2 + \Delta y^2,$$

hence $\lim_{\Delta x \neq 0} \left(\frac{\overline{PP'}}{\Delta x} \right)^2 = 1 + \lim_{\Delta x \neq 0} \left(\frac{\Delta y}{\Delta x} \right)^2$.

In taking the first limit we can replace the chord PP' by the arc Δs , since *

$$\lim_{P' \neq P} \frac{\overline{PP'}}{\widetilde{PP'}} = 1.$$

* A formal proof of this statement can be given as follows. We have:

(A) $\overline{PP'} < \widetilde{PP'} < PQ + QP'$,

since (a) a straight line is the shortest distance between two points and (b) a convex curved line is less than a broken line that envelops it and has the same extremities. From (A) follows:

$$1 < \frac{\widetilde{PP'}}{\overline{PP'}} < \frac{PQ}{\overline{PP'}} + \frac{QP'}{\overline{PP'}}.$$

We thus obtain the relation :

$$(1) \quad (D_x s)^2 = 1 + (D_x y)^2 \quad \text{or} \quad ds^2 = dx^2 + dy^2.$$

Geometrically we see that ds is represented by the hypotenuse PQ of the right triangle PMQ . Furthermore :

$$(2) \quad \left\{ \begin{array}{l} \sin \tau = \frac{dy}{ds} = \frac{dy}{\sqrt{dx^2 + dy^2}} = \frac{\frac{dy}{dx}}{\sqrt{1 + \frac{dy^2}{dx^2}}}, \\ \cos \tau = \frac{dx}{ds} = \frac{dx}{\sqrt{dx^2 + dy^2}} = \frac{1}{\sqrt{1 + \frac{dy^2}{dx^2}}}. \end{array} \right.$$

These formulas are written on the supposition that the tangent PT is drawn in the direction in which s increases and that x and s increase simultaneously. If x decreases as s increases, we must place a minus sign before each radical.

Polar Coordinates. Similar considerations in the case of the curve $r = f(\theta)$ lead to the following formulas, cf. Fig. 29 :

$$\overline{PP'}^2 = P'M^2 + MP^2, \quad \lim_{\Delta r \neq 0} \left(\frac{\overline{PP'}}{\Delta r} \right)^2 = \lim_{\Delta r \neq 0} \left(\frac{P'M}{\Delta r} \right)^2 + \lim_{\Delta r \neq 0} \left(\frac{MP}{\Delta r} \right)^2.$$

$$(3) \quad (D_r s)^2 = 1 + r^2 (D_r \theta)^2 \quad \text{or} \quad ds^2 = dr^2 + r^2 d\theta^2.$$

As P' approaches P , the ratio

$$\frac{PQ}{PP'} = \frac{\sqrt{dx^2 + dy^2}}{\sqrt{\Delta x^2 + \Delta y^2}} = \frac{\sqrt{1 + \frac{dy^2}{dx^2}}}{\sqrt{1 + \frac{\Delta y^2}{\Delta x^2}}}$$

obviously approaches 1. QP' , which is equal numerically to $\Delta y - dy$, is an infinitesimal of higher order than Δx and hence than the chord PP' ; hence $QP' / \overline{PP'}$ approaches 0 and thus the limit of the right-hand member is 1. Hence the middle term approaches 1, q. e. d.

Furthermore:

$$(4) \quad \sin \psi = \frac{rd\theta}{ds}, \quad \cos \psi = \frac{dr}{ds},$$

the tangent PT being drawn in the direction of the increasing s . Beside these there is the formula of § 2:

$$(5) \quad \tan \psi = \frac{rd\theta}{dr}.$$

7. Rates and Velocities. The principles of velocities and rates were treated in Chap. II. We are now in a position to deal with a larger class of problems.

Example 1. A railroad train is running at 30 miles an hour along a curve in the form of a parabola:

$$(A) \quad y^2 = 500x,$$

the axis of the parabola being east and west and the foot being taken as the unit of length. The sun is just rising in the east. Find how fast the shadow of the locomotive is moving along the wall of the station, which is north and south.

Since 30 m. an h. is equivalent to 44 ft. a sec., the problem is:

$$\text{Given } \frac{ds}{dt} = 44; \quad \text{to find } \frac{dy}{dt}.$$

$$\text{From (A): } 2y dy = 500 dx, \quad dx = \frac{y dy}{250}.$$

Substituting this value of dx in (1), § 6, we get:

$$ds^2 = dx^2 + dy^2 = \frac{y^2 dy^2}{250^2} + dy^2, \quad dy = \frac{250 ds}{\sqrt{250^2 + y^2}}.$$

Hence, dividing through by dt and writing for ds/dt its value, we get:

$$\frac{dy}{dt} = \frac{250 \times 44}{\sqrt{250^2 + y^2}}.$$

In particular: $\left[\frac{dy}{dt} \right]_{y=250} = \frac{44}{\sqrt{2}}$ ft. a sec., or 21.2 m. an h.

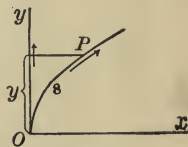

FIG. 31

Example 2. A man standing on a wharf is drawing in the painter of a boat at the rate of 2 ft. a sec. His hands are 6 ft. above the bow of the boat. How fast is the boat moving through the water when there are still 10 ft. of painter out?

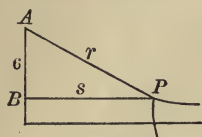

FIG. 32

Let r be the number of feet of painter out at any instant. Then

$$\frac{dr}{dt} = -2.$$

For dr/dt gives the rate at which r is increasing with the time, and since r is decreasing, the rate is negative.

We wish to find the rate at which P is moving. Let s denote the horizontal distance PB of P from the wharf. Then ds/dt gives this rate numerically, but algebraically ds/dt is negative. We desire, then, the value of $-ds/dt$.

Since s and r are connected by the relation :

$$s^2 = r^2 - 36,$$

we have

$$2s ds = 2r dr,$$

$$-\frac{ds}{dt} = -\frac{r}{s} \frac{dr}{dt} = \frac{2r}{\sqrt{r^2 - 36}}.$$

Hence, finally : $\left[-\frac{ds}{dt} \right]_{r=10} = \left[\frac{2r}{\sqrt{r^2 - 36}} \right]_{r=10} = 2\frac{1}{2}$ ft. a sec.

The student will note that the method of solution consists in determining first the velocity at an arbitrary instant, and then substituting the particular value $r = 10$ into the result thus obtained.

EXERCISES

1. A lamp-post is distant 10 ft. from a street-crossing and 60 ft. from the houses on the opposite side of the street. A man crosses the street, walking on the crossing at the rate of 4 m. an h. in the direction toward the lamp-post. How fast is his shadow moving along the walls of the houses when he

is two-thirds of the way over? When he is 55 ft. from the houses? *Ans.* 6 m. an h. and 96 m. an h., respectively.

2. A kite is 150 ft. high and there are 250 ft. of cord out. If the kite moves horizontally at the rate of 4 m. an h. directly away from the person who is flying it, how fast is the cord being paid out? *Ans.* $3\frac{1}{5}$ m. an h.

3. A point describes a circle with constant velocity. Show that the velocity with which its projection moves along a given diameter is proportional to the distance of the point from this diameter.

4. A revolving light sends out a bundle of rays that are approximately parallel, its distance from the shore, which is a straight beach, being half a mile, and it makes one revolution in a minute. Find how fast the light is travelling along the beach when at the distance of a mile from the nearest point of the beach. *Ans.* 15.7 m. a m.

5. The sun is just setting as a base ball is thrown vertically upward so that its shadow mounts to the highest point of the dome of an observatory. The dome is 50 ft. in diameter. Find how fast the shadow of the ball is moving along the dome one second after it begins to fall, and also how fast it is moving just after it begins to fall.

EXERCISES

Determine the maxima and minima of the following functions:

1. $x \log x$. *Ans.* A minimum when $x = .3679$.
2. $x \cos x$. *Ans.* $\begin{cases} \text{A maximum when } x = \cot x, 0 < x < \frac{1}{2}\pi; \\ \text{A minimum " " " } -\frac{1}{2}\pi < x < 0. \end{cases}$
3. xe^{-x} . 9. $\sin 2x - x$. (15). $e^{-kt} \cos(nt + \gamma)$.
4. $x^n e^{-x}$. 10. $\sin x \cos^3 x$. 16. $x - \tan x$.
5. $x^2 \log \frac{1}{x}$. 11. $\frac{\cos x}{1 + \cot x}$. 17. $x + \tan x$.
6. $\frac{x}{\log x}$. (12). $\frac{x}{1 + x \tan x}$. 18. $x^{\frac{1}{x}}$.
7. $\sin x + \cos x$. (13). x^x . 19. $\left(\log \frac{1}{x}\right)^{\frac{1}{x}}$.
8. $x + \sin x$. (14). $e^x \cos 2x$. 20. $\tan x - 2 \sin x$.
21. Prove that

$$|\sin x + \cos x| \leq \sqrt{2}.$$

22. Show how to draw the shortest possible line from the point $(\frac{5}{9}, 0)$ to the curve $y = \frac{4}{3}x^{\frac{3}{2}}$.

23. A rectangular piece of ground of given area is to be enclosed by a wall and divided into three equal areas by partition walls parallel to one of the sides. What must be the dimensions of the rectangle that the length of wall may be a minimum?

24. Find the most economical proportions for a conical tent.

25. A foot-ball field $2a$ ft. long and $2b$ ft. broad is to be surrounded by a running track consisting of two straight sides (parallel to the length of the field) joined by semicircular ends. The track is to be $4c$ ft. long. Show how it should be made in order that the shortest distance between the track and the foot-ball field may be as great as possible.

26. The number of ems (*i.e.* the number of sq. cms. of text) on this page and the breadths of the margins being given, what ought the length and breadth of the page to be that the amount of paper used may be as small as possible?

27. A statue 10 ft. high stands on a pedestal that is 50 ft. high. How far ought a man whose eyes are 5 ft. above the ground to stand from the pedestal in order that the statue may subtend the greatest possible angle?

28. A can-buoy in the form of a double cone is to be made from two equal circular iron plates. If the radius of each plate is a , find the radius of the base of the cone when the buoy is as large as possible. *Ans.* $a\sqrt{\frac{2}{3}}$.

29. At what point on the line joining the centres of two spheres must a light be placed to illuminate the largest possible amount of spherical surface?

30. A block of stone is to be drawn along the floor by a rope. Find the angle which the rope should make with the horizontal in order that the tension may be as small as possible.

Ans. The angle of friction.

31. Into a full conical wine-glass whose depth is a and generating angle α there is carefully dropped a spherical ball of such a size as to cause the greatest overflow. Show that the radius of the ball is

$$\frac{a \sin \alpha}{\sin \alpha + \cos 2\alpha}.$$

32. The illumination of a small plane surface by a luminous point is proportional to the cosine of the angle between the rays of light and the normal to the surface, and inversely proportional to the square of the distance of the luminous point from the surface. At what height on the wall should a gas-burner be placed in order to light most brightly a portion of the floor a ft. distant from the wall?

Ans. About $\frac{7}{10}a$ ft. above the floor.

33. A gutter whose cross-section is an arc of a circle is to be made by bending into shape a strip of copper. If the width of the strip is a , find the radius of the cross-section when the carrying capacity of the gutter is a maximum. *Ans.* a/π .

34. If, in the preceding problem, the cross-section of the gutter is to be a broken line made up of three pieces each 4 in. long, the middle piece being horizontal, how wide should the gutter be at the top? *Ans.* 8 in.

35. A wall 27 ft. high is 64 ft. from a house. Find the length of the shortest ladder that will reach the house if one end rests on the ground outside the wall.

36. A long strip of paper 8 in. wide is cut off square at one end. A corner of this end is folded over onto the opposite side, thus forming a triangle. Find the area of the smallest triangle that can thus be formed.

37. In the preceding question, when will the length of the crease be a minimum?

38. The captain of a man-of-war saw, one dark night, a privateersman crossing his path at right angles and at a distance ahead of c miles. The privateersman was making a miles an hour, while the man-of-war could make only b miles in the same time. The captain's only hope was to cross the track of the privateersman at as short a distance as possible under his stern, and to disable him by one or two well-directed shots; so the ship's lights were put out and her course altered in accordance with this plan. Show that the man-of-war crossed the privateersman's track $\frac{c}{b} \sqrt{a^2 - b^2}$ miles astern of the latter.

If $a = b$, this result is absurd. Explain.

39. Find the area of the smallest triangle cut off from the first quadrant by a tangent to the ellipse

$$\frac{x^2}{a^2} + \frac{y^2}{b^2} = 1. \quad \text{Ans. } ab.$$

40. Assuming that the values of diamonds are proportional, other things being equal, to the squares of their weights, and that a certain diamond which weighs one carat is worth \$ m , show that it is safe to pay at least \$ $8m$ for two diamonds which together weigh 4 carats, if they are of the same quality as the one mentioned.

41. A man is out in a power-boat a miles from the nearest point A of a straight beach. He wishes to reach a point inland whose distance from the nearest point B of the beach is b miles. The distance AB is c miles. If he can make v_1 m. an h. in his boat, but can walk only v_2 m. an h., what point of the beach ought he to head for in order to reach his destination in the shortest possible time?

Ans. $\frac{\sin \theta_1}{v_1} = \frac{\sin \theta_2}{v_2}$, where θ_1 and θ_2 are the angles that his paths make with a normal to the beach.

This problem is identical with that of finding the path of a ray of light that traverses two media separated by a plane surface, as for example when we look at an object submerged in water.

42. Assuming the law of the refraction of light stated in the last problem, show that a ray of light in passing through a prism will experience the maximum deflection from its original direction when the incident ray at one face and the refracted ray at the other make equal angles with their respective faces.

43. A steel girder 25 ft. long is moved on rollers along a passageway 12.8 ft. wide, and into a corridor at right angles to the passageway. Neglecting the horizontal width of the girder, find how wide the corridor must be in order that the girder may go round the corner. *Ans.* 5.4 ft.

44. A town A situated on a straight river, and another town B , a miles further down the river and b miles back from the river are to be supplied with water from the river pumped

by a single station. The main from the waterworks to A will cost $\$m$ per mile and the main to B will cost $\$n$ per mile. Where on the river-bank ought the pumps to be placed?

45. When a voltaic battery of given electromotive force (E volts) and given internal resistance (r ohms) is used to send a steady current through an external circuit of R ohms resistance, an amount of work (W) equivalent to

$$\frac{E^2 R}{(r + R)^2} \times 10^7 \text{ ergs}$$

is done each second in the outside circuit. Show that, if different values be given to R , W will be a maximum when $R = r$.

46. Show that, if a point describe a curve $y = f(x)$ with a constant or variable velocity v , the rates at which its projections on the coordinate axes are moving will be respectively:

$$\frac{dx}{dt} = v \cos \tau, \quad \frac{dy}{dt} = v \sin \tau.$$

If the velocities of its projections along the axes, namely dx/dt and dy/dt , are known, then

$$v = \frac{ds}{dt} = \sqrt{\frac{dx^2}{dt^2} + \frac{dy^2}{dt^2}}, \quad \tan \tau = \frac{dy}{dt} / \frac{dx}{dt}.$$

47. If in the preceding problem the curve be given in polar coordinates, $r = f(\theta)$, and we consider two lines parallel and perpendicular respectively to the radius vector at any instant, the rates at which its projections on these lines are moving will be:

$$\frac{dr}{dt} = v \cos \psi, \quad r \frac{d\theta}{dt} = v \sin \psi.$$

48. A projectile, moving under the force of gravity, describes a parabola:

$$x = v_0 \cos \alpha \cdot t, \quad y = v_0 \sin \alpha \cdot t - 16t^2,$$

provided that the resistance of the atmosphere has no appreciable influence on the motion. Here, α denotes the initial angle of elevation and v_0 the initial velocity. Determine the velocity of the projectile in its path.

Ans. $\sqrt{v_0^2 - 64v_0 \sin \alpha \cdot t + 1024t^2}$

49. A ladder 25 ft. long rests against a house. A man takes hold of the lower end and walks away, carrying it with him, at the rate of 2 m. an h. How fast is the upper end descending when the man is 8 ft. from the house?

50. A conical filtering glass is nearly filled with water. The water is running out of an opening in the vertex at a constant rate. How fast is the surface of the water falling?

51. Let AB , Fig. 33, represent the rod that connects the piston of a stationary engine with the fly-wheel. If u denotes the velocity of A in its rectilinear path, and v that of B in its circular path, show that

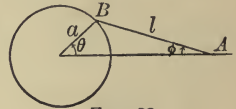

FIG. 33

$$u = (\sin \theta + \cos \theta \tan \phi) v.$$

52. Find the velocity of the piston of a locomotive when the speed of the axle of the drivers is given.

53. A draw-bridge 30 ft. long is being slowly raised by chains passing over a windlass and being drawn in at the rate of 8 ft. a minute. A distant electric light sends out horizontal rays and the bridge thus casts a shadow on a vertical wall, consisting of the other half of the bridge, which has been already raised.

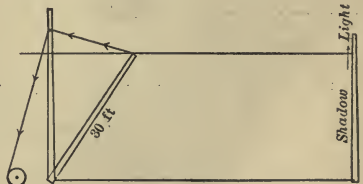

FIG. 34

Find how fast the shadow is creeping up the wall when half the chain has been drawn in.

54. The sun is just setting in the west as a horse is running around an elliptical track at the rate of m miles an hour. The axis of the ellipse lies in the meridian. Find the rate at which the horse's shadow moves on a fence beyond the track and parallel to the axis.

55. Differentiate y when

$$2x \sin y = 3y \sin x.$$

$$\text{Ans. } \frac{dy}{dx} = \frac{3y \cos x - 2 \sin y}{2x \cos y - 3 \sin x}.$$

56. Differentiate y when

$$y = x \log(x - y).$$

57. Plot the curve

$$r = a \cos 3\theta,$$

determining where the tangent is parallel to the axis of a lobe.

58. Plot the following curves :

$$(a) \quad y = x + \sin x.$$

$$(c) \quad r = a \sin 3\theta.$$

$$(b) \quad y = xe^{-x}.$$

$$(d) \quad r = \frac{1}{\theta}.$$

59. Locate the roots of the equation

$$x = \cot x$$

and hence discuss completely the maxima and minima of the function in Question 2.

60. The equation

$$\theta(1 + \cos \theta) = 2 \sin \theta$$

has one root in the interval $-\pi/2 < \theta < \pi/2$, namely $\theta = 0$. Has it others?

61. Find all the roots of the equation

$$(1 + b^2) \tan^{-1} b = b.$$

CHAPTER VI

INTEGRATION

1. **The Area under a Curve.** Let it be required to compute the area bounded by the curve

$$(1) \quad y = f(x),$$

the axis of x , and two ordinates whose abscissas are $x = a$ and $x = b$, ($a < b$). We can proceed as follows. Consider first the variable area, A , bounded by the first three lines just mentioned and an ordinate whose abscissa x is variable. Then A is a function of x . For, when we assign to x any value between the limits a and b in question, the corresponding value of the area is thereby determined and could actually be computed by plotting the figure on squared paper and counting the squares, or by cutting the figure out of a sheet of paper or tin and weighing the piece.

If, then, we can obtain an analytic expression for this function of x , holding for all values of x from a to b , we can then set $x = b$ in this formula and thus solve the above problem.

To do this, begin by giving to x an arbitrary value, $x = x_0$, and denoting the corresponding value of A by A_0 . Next, give to x an increment, Δx , and denote the corresponding increment in A by ΔA . We can approximate to the area ΔA by means of two rectangles, as shown in the figure, and thus we get:

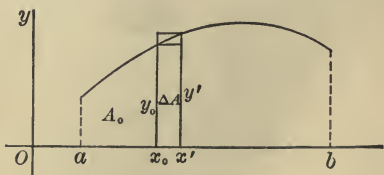

FIG. 35

$$y_0 \Delta x < \Delta A < (y_0 + \Delta y) \Delta x.$$

Hence
$$y_0 < \frac{\Delta A}{\Delta x} < y_0 + \Delta y.$$

(If $f(x)$ decreases as x increases, the inequality signs will be reversed.) Allowing now Δx to approach 0 as its limit, we see that the variable $\Delta A/\Delta x$ always lies between the fixed quantity y_0 and the variable $y_0 + \Delta y$, whose limit is y_0 . Hence

$$\lim_{\Delta x \rightarrow 0} \frac{\Delta A}{\Delta x} = y_0,$$

or, dropping the subscripts, we have :

$$(2) \quad D_x A = y.$$

For example, let the curve be

$$y = x^2$$

and let $a = 1$, $b = 4$. Then

$$D_x A = x^2$$

and the question is: What function must we differentiate in order to get x^2 ? We readily see that $x^3/3$ is such a function. But this is not the only one. For, if we add any constant, $x^3/3 + C$ will also differentiate into x^2 . We shall see later that this is the most general function whose derivative is x^2 , and hence A must be of the form :

$$(3) \quad A = \frac{x^3}{3} + C.$$

This formula is not wholly definite, for C may be any constant. On the other hand we have not as yet brought all our data into play, for we have as yet said nothing about the fact that the left-hand ordinate shall correspond to the abscissa $x = 1$. Now the variable area A will be small when x is only a little greater than 1, and it will approach 0 as its limit when x approaches 1. If, then, (3) is to be a true formula, it must give 0 as the value of A when $x = 1$, or

$$(4) \quad 0 = \frac{1}{3} + C, \quad C = -\frac{1}{3}.$$

$$(5) \quad \therefore A = \frac{x^3}{3} - \frac{1}{3}.$$

Having thus found the variable area, we can now obtain the area we set out to compute by putting $x = 4$ in (5):

$$[A]_{x=4} = \frac{64}{3} - \frac{1}{3} = 21.$$

The process of finding the area under a curve is thus seen to be as follows. First find a function which when differentiated will give the ordinate $y = f(x)$ of the curve (1) before us; and add an undetermined constant to this function. Next, determine this constant by requiring that A shall $= 0$ when $x = a$. Thus the variable area is completely expressed as a function of x . Lastly, substitute $x = b$ in this formula.

EXERCISES

1. Show that, if the area in the foregoing example had been measured from the ordinate $x = 2$, the value of the constant C would have been $-2\frac{2}{3}$:

$$A = \frac{x^3}{3} - 2\frac{2}{3};$$

and if it had been measured from the origin, then C would have been $= 0$:

$$A = \frac{x^3}{3}.$$

2. If, in (1), $y = f(x) = x$, the curve is a straight line; and if $a = 6$, $b = 20$, the figure is a trapezoid. Compute its area by the above method and check your result by elementary geometry.

3. Find the area under the curve

$$y = x^4,$$

lying between the ordinates whose abscissas are $x = 10$ and $x = 20$.

Ans. 620,000.

4. Find the area of one arch of the curve

$$y = \sin x. \quad \text{Ans. } 2$$

5. Find the area under that portion of the curve

$$y = 1 - x^2$$

which lies above the axis of x .

6. A river bends around a meadow, making a curve that is approximately a parabola:

$$y = x - 4x^2,$$

referred to a straight road that crosses the river, as axis of x ; the mile is taken as the unit. How many acres of meadow are there between the road and the river? *Ans.* $6\frac{2}{3}$, nearly.

2. The Integral. In the preceding chapters we have treated the problem: Given a function; to find its derivative. The examples of the last paragraph are typical for the inverse problem: Given the derivative of a function; to find the function. Stated in equations, the problem is this. If

$$D_x U = u, \quad \text{or} \quad dU = u dx,$$

where u is given, to find U .

The function U is called the *integral* of u with respect to x and is denoted as follows:

$$U = \int u dx.$$

Thus we have the following

DEFINITION OF AN INTEGRAL. The function U is said to be the integral of u :

$$U = \int u dx,$$

if $D_x U = u, \quad \text{or} \quad dU = u dx.$

The given function u is called the *integrand*.

More precisely, we should say that U is an integral of u ; for $U + C$ is evidently an integral, too, C being any constant.

For example:

$$(6) \quad \int x^n dx = \frac{x^{n+1}}{n+1} + C, \quad n \neq -1.$$

For, if we differentiate the function:

$$U = \frac{x^{n+1}}{n+1} + C$$

with respect to x , we get:

$$D_x U = x^n,$$

and x^n is the integrand u of the integral in question.

The following theorem is fundamental in the theory of integration.

THEOREM A. *If two functions have the same derivative:*

$$(A) \quad D_x f(x) = D_x \phi(x),$$

they differ from each other only by a constant.

Since the derivative of their difference is 0:

$$D_x [f(x) - \phi(x)] = 0,$$

the theorem is equivalent to the following: *If the derivative of a function is always 0:*

$$(B) \quad D_x \Phi(x) \equiv 0,$$

the function is a constant.

Geometrically, the truth of this last theorem is exceedingly plausible. The graph of the function

$$y = \Phi(x) = C$$

is a straight line parallel to the axis of x , and its slope is 0. If, now, conversely, the slope of a curve is always 0, what can the curve be other than a straight line parallel to the axis of x ? For an analytic proof of these theorems cf. the chapter on the Law of the Mean.

From Theorem A it follows that all the integrals of a given function differ from one another only by additive constants. For, if U and U' are any two integrals of $f(x)$:

$$D_x U = f(x), \quad D_x U' = f(x),$$

then U and U' have the same derivative.

Differentiation and integration are inverse processes, and so we have:

$$D_x \int u \, dx = u \quad \text{or} \quad d \int u \, dx = u \, dx;$$

$$\int D_x U \, dx = U + C \quad \text{or} \quad \int dU = U + C.$$

THEOREM I. *A constant factor can always be taken out from under the sign of integration:*

$$(I) \quad \int cu \, dx = c \int u \, dx.$$

Consider the two functions that enter in (I). We have:

$$D_x \int cu \, dx = cu,$$

$$D_x \left[c \int u \, dx \right] = c D_x \int u \, dx = cu,$$

i.e., the derivatives of these functions are identical. Hence the functions themselves can differ at most by a constant:

$$\int cu \, dx = c \int u \, dx + k,$$

and so by choosing the constant of integration in the integral on the left-hand side suitably, we can make $k = 0$.

THEOREM II. *The integral of the sum of two functions is equal to the sum of their integrals:*

$$(II) \quad \int (u + v) \, dx = \int u \, dx + \int v \, dx.$$

The proof is like that of Theorem I:

$$D_x \int (u + v) dx = u + v,$$

$$D_x \left[\int u dx + \int v dx \right] = D_x \int u dx + D_x \int v dx = u + v.$$

Hence the functions on the two sides of (II) differ at most by a constant, k . The constants in any two of the integrals may be chosen at pleasure and then the constant in the third integral can be so taken that $k = 0$.

Integration of Polynomials. By the aid of the above theorems any polynomial can be integrated. For example:

$$\begin{aligned} \int (a + bx + cx^2) dx &= \int a dx + \int bx dx + \int cx^2 dx \\ &= a \int dx + b \int x dx + c \int x^2 dx \\ &= ax + b \frac{x^2}{2} + c \frac{x^3}{3} + C. \end{aligned}$$

Area under a Curve. We can now express the area discussed in § 1 in the form:

$$(7) \quad A = \int y dx \quad \text{or} \quad A = \int f(x) dx.$$

EXERCISES

Evaluate the following integrals.

$$1. \int (3 - 4x - 9x^2) dx. \quad \text{Ans. } 3x - 2x^2 - x^3 + C.$$

$$2. \int \sqrt{x} dx. \quad \text{Ans. } \frac{2}{3} x^{\frac{3}{2}} + C.$$

$$3. \int \frac{dx}{x^2}. \quad \text{Ans. } -\frac{1}{x} + C.$$

$$4. \int \frac{1+x+x^2}{3} dx.$$

5. $\int \frac{dx}{\sqrt{x}}$

7. $\int (x^{\frac{2}{3}} - x^{-\frac{2}{3}}) dx$

6. $\int \frac{1+x}{\sqrt{x}} dx$

8. $\int \frac{1+x+x^2}{x} dx$

9. Find the area above the positive axis of x bounded by the curve:

$$y = (x^2 - 1)(4 - x^2). \quad \text{Ans. } 1\frac{7}{15}.$$

10. Find the area enclosed between the two parabolas:

$$y = x^2, \quad y^2 = x.$$

3. Special Formulas of Integration. Corresponding to the Special Formulas of Differentiation, of Chap. IV, we can write down a list of special formulas of integration, by means of which, together with the general methods discussed in this chapter, all the simpler integrals can be evaluated. Each formula can be proven by differentiating each side of the equation.

SPECIAL FORMULAS OF INTEGRATION

$$1. \quad \int x^n dx = \frac{x^{n+1}}{n+1}, \quad n \neq -1.$$

$$2. \quad \int \sin x dx = -\cos x.$$

$$3. \quad \int \cos x dx = \sin x.$$

$$4. \quad \int \frac{dx}{x} = \log x.$$

$$5. \quad \int e^x dx = e^x.$$

$$6. \quad \int \frac{dx}{1+x^2} = \tan^{-1}x.$$

$$7. \quad \int \frac{dx}{\sqrt{1-x^2}} = \sin^{-1}x, \\ = -\cos^{-1}x.$$

$$8. \quad \int \sec^2 x \, dx = \tan x.$$

$$9. \quad \int \csc^2 x \, dx = -\cot x.$$

To these may be added the formulas :

$$10. \quad \int \frac{dx}{\sqrt{2x-x^2}} = \text{vers}^{-1}x.$$

$$11. \quad \int a^x dx = \frac{a^x}{\log a}.$$

We have omitted the constant of integration each time for the sake of simplicity. But the student must not forget to insert it in applying these formulas in a given example. Moreover, we have not included the formula :

$$\int 0 \, dx = C.$$

4. Integration by Substitution. Many integrals can be obtained from the special formulas of § 3 by introducing a new variable of integration. The following examples will illustrate the method.

Example 1. To find $\int \sqrt{a+bx} \, dx$.

Let $a+bx=y$. Then $b \, dx = dy$

and $\sqrt{a+bx} \, dx = \frac{1}{b} y^{\frac{1}{2}} dy$.

Integrating each side of this equation, we get :

$$\int \sqrt{a+bx} \, dx = \frac{1}{b} \int y^{\frac{1}{2}} dy = \frac{1}{b} \frac{y^{\frac{3}{2}}}{\frac{3}{2}} + C.$$

Hence
$$\int \sqrt{a+bx} \, dx = \frac{2\sqrt{(a+bx)^3}}{3b} + C.$$

Example 2. To find $\int \cos ax \, dx.$

Let $ax = y.$ Then $a \, dx = dy,$

$$\cos ax \, dx = \frac{1}{a} \cos y \, dy,$$

and
$$\int \cos ax \, dx = \frac{1}{a} \int \cos y \, dy = \frac{1}{a} \sin y + C = \frac{1}{a} \sin ax + C.$$

Example 3. To find $\int x \sqrt{a^2 + x^2} \, dx.$

Let $x^2 = y.$ Then $2x \, dx = dy,$

$$x \sqrt{a^2 + x^2} \, dx = x \sqrt{a^2 + y} \frac{dy}{2x} = \frac{1}{2} \sqrt{a^2 + y} \, dy,$$

and
$$\int x \sqrt{a^2 + x^2} \, dx = \frac{1}{2} \int \sqrt{a^2 + y} \, dy.$$

This last integral is a special case of the integral of Example 1. For, if the a of that formula is replaced by a^2 , the b by 1, and the x by y , we have the present integral. Hence

$$\int x \sqrt{a^2 + x^2} \, dx = \frac{1}{3}(a^2 + x^2)^{\frac{3}{2}} + C.$$

We might have set $a^2 + x^2 = y.$

Example 4. To find $\int \tan x \, dx.$

Here
$$\int \tan x \, dx = \int \frac{\sin x \, dx}{\cos x} = \int \frac{-d \cos x}{\cos x} = -\log \cos x + C.$$

In substance, we have introduced a new variable, $\cos x = y.$ But in practice it is often simpler, as here, to refrain from actually writing a new letter.

In the above examples we have tacitly assumed that if x and y are functions one of the other, and if $f(x)$ and $\phi(y)$ are two functions such that

$$f(x) dx = \phi(y) dy,$$

then

$$\int f(x) dx = \int \phi(y) dy.$$

We can justify this assumption without difficulty. For

$$D_x \int f(x) dx = f(x),$$

$$D_x \int \phi(y) dy = D_y \int \phi(y) dy \cdot D_x y = \phi(y) D_x y;$$

and since

$$f(x) = \phi(y) \frac{dy}{dx},$$

it follows that the above integrals differ from each other at most by a constant, k . Hence, if the constant of integration in one of these integrals is chosen at pleasure, the constant of integration in the other can be so determined that $k = 0$.

This theorem in integration corresponds to Theorem V of Chap. II in differentiation. And, as in the case of that theorem, the use of differentials, — and it is to this fact that their importance is due, — reduces the theorem in form to an algebraic identity:

$$\int u dx = \int \left[u \frac{dx}{dy} \right] dy.$$

EXERCISES

Evaluate the following integrals :

1. $\int \sqrt{1-x} dx.$ *Ans.* $-\frac{2}{3}(1-x)^{\frac{3}{2}} + C.$

2. $\int \sqrt[3]{1+2x} dx.$ *Ans.* $\frac{3}{8}(1+2x)^{\frac{4}{3}} + C.$

$$3. \int \frac{dx}{\sqrt{3-2x}} \quad 5. \int (a+bx)^n dx \quad 7. \int \cos \frac{x}{2} dx.$$

$$4. \int \frac{dx}{\sqrt[4]{a+bx}} \quad 6. \int \sin ax dx \quad 8. \int \sin(\pi x + \gamma) dx.$$

$$9. \int \frac{dx}{a^2+x^2} \quad \text{Ans. } \frac{1}{a} \tan^{-1} \frac{x}{a} + C.$$

$$10. \int \frac{dx}{\sqrt{a^2-x^2}} \quad \text{Ans. } \sin^{-1} \frac{x}{a} + C.$$

$$11. \int \frac{x dx}{\sqrt{a^2-x^2}} \quad \text{Ans. } -\sqrt{a^2-x^2} + C.$$

$$12. \int x^2 \sqrt{a^3+x^3} dx \quad 14. \int \frac{dx}{a+bx} \quad 16. \int x \sin x^2 dx.$$

$$13. \int x e^{-x^2} dx \quad 15. \int \frac{x dx}{a+bx^2} \quad 17. \int \frac{dx}{(1-x)^2}.$$

$$18. \int \cot x dx \quad \text{Ans. } \log \sin x + C.$$

5. Integration by Ingenious Devices.

Example 1. To find $\int \cos^2 \theta d\theta$.

Set $\cos^2 \theta = \frac{1}{2}(1 + \cos 2\theta).$

Then $\int \cos^2 \theta d\theta = \frac{1}{2} \int (1 + \cos 2\theta) d\theta = \frac{1}{2} \theta + \frac{1}{4} \sin 2\theta + C,$

(8) $\therefore \int \cos^2 \theta d\theta = \frac{1}{2}(\theta + \sin \theta \cos \theta) + C.$

We can now evaluate an important integral, namely :

$$\int \sqrt{a^2-x^2} dx.$$

Let $x = a \sin \theta; \quad dx = a \cos \theta d\theta,$

$$\sqrt{a^2-x^2} dx = a^2 \cos^2 \theta d\theta,$$

$$\int \sqrt{a^2 - x^2} dx = a^2 \int \cos^2 \theta d\theta = \frac{a^2}{2} (\theta + \sin \theta \cos \theta) + C,$$

$$(9) \quad \therefore \int \sqrt{a^2 - x^2} dx = \frac{1}{2} \left(x \sqrt{a^2 - x^2} + a^2 \sin^{-1} \frac{x}{a} \right) + C.$$

Example 2. To find $\int \frac{dx}{a^2 - x^2}$.

The integrand can be written in the form :

$$\frac{1}{a^2 - x^2} = \frac{1}{2a} \left[\frac{1}{x+a} - \frac{1}{x-a} \right].$$

Hence
$$\int \frac{dx}{a^2 - x^2} = \frac{1}{2a} \int \frac{dx}{x+a} - \frac{1}{2a} \int \frac{dx}{x-a}$$

$$= \frac{1}{2a} \left[\log(x+a) - \log(x-a) \right] + C;$$

$$(10) \quad \therefore \int \frac{dx}{a^2 - x^2} = \frac{1}{2a} \log \frac{x+a}{x-a} + C.*$$

Example 3. To find $\int \frac{d\theta}{\sin \theta}$.

First Method.
$$\int \frac{d\theta}{\sin \theta} = \int \frac{d\theta}{2 \sin \frac{\theta}{2} \cos \frac{\theta}{2}}$$

* In case $-a < x < a$, formula (10) involves the logarithm of a negative quantity. We can avoid this difficulty by writing the second term in the bracket as $+1/(a-x)$, the corresponding integral thus becoming

$$\int \frac{dx}{a-x} = -\log(a-x).$$

This leads to the formula :

$$(10') \quad \int \frac{dx}{a^2 - x^2} = \frac{1}{2a} \log \frac{a+x}{a-x} + C.$$

It will be shown later in the Calculus that, in the domain of imaginaries, the logarithms of (10) and (10') differ from each other only by an imaginary constant, and since the latter may be included in the constant of integration, (10) and (10') may be regarded as equivalent formulas.

Let $\frac{\theta}{2} = \phi$. Then the last integral becomes :

$$\int \frac{d\phi}{\sin \phi \cos \phi} = \int \frac{\sec^2 \phi d\phi}{\tan \phi} = \int \frac{d \tan \phi}{\tan \phi} = \log \tan \phi + C.$$

$$(11) \quad \therefore \int \frac{d\theta}{\sin \theta} = \log \tan \frac{\theta}{2} + C.$$

Second Method.

$$\begin{aligned} \int \frac{d\theta}{\sin \theta} &= \int \frac{\sin \theta d\theta}{\sin^2 \theta} \\ &= - \int \frac{d \cos \theta}{1 - \cos^2 \theta} = -\frac{1}{2} \log \frac{1 + \cos \theta}{1 - \cos \theta} + C. \end{aligned}$$

The fraction $\frac{1 + \cos \theta}{1 - \cos \theta} = \frac{\cos^2 \frac{\theta}{2}}{\sin^2 \frac{\theta}{2}} = \frac{1}{\tan^2 \frac{\theta}{2}}$.

$$(11) \quad \therefore \int \frac{d\theta}{\sin \theta} = \log \tan \frac{\theta}{2} + C.$$

EXERCISES

1. $\int \sin^2 \theta d\theta.$

Ans. $\frac{1}{2}(\theta - \sin \theta \cos \theta) + C.$

2. $\int \frac{d\theta}{1 + \cos \theta}.$

3. $\int \frac{d\theta}{1 - \cos \theta}.$

4. $\int \frac{d\theta}{\cos \theta}.$

Ans. $\log \tan \left(\frac{\pi}{4} + \frac{\theta}{2} \right) + C,$

or $\frac{1}{2} \log \frac{1 + \sin \theta}{1 - \sin \theta} + C,$ or $\log (\sec \theta + \tan \theta) + C.$

5. $\int \frac{dx}{\sqrt{x^2 + a^2}}.$

Ans. $\log (x + \sqrt{x^2 + a^2}) + C.$

Suggestion : Let $x = a \tan \theta.$

6. $\int \frac{dx}{\sqrt{x^2 - a^2}}.$

Ans. $\log (x + \sqrt{x^2 - a^2}) + C.$

6. **Integration by Parts.** The formula of differentiation:

$$d(uv) = u dv + v du, \quad (19)$$

leads to a formula of integration:

$$(III) \quad \int u dv = uv - \int v du.$$

Integration by means of this formula is known as *integration by parts*.

Example 1. To find $\int xe^x dx$.

Let $u = x, \quad dv = e^x dx;$

then $du = dx, \quad v = \int e^x dx = e^x,$

and $\int xe^x dx = xe^x - \int e^x dx = (x - 1)e^x + C.$

Example 2. To find $\int \log x dx$.

Let $u = \log x, \quad dv = dx;$

then $du = \frac{dx}{x}, \quad v = x,$

and $\int \log x dx = x \log x - \int x \frac{dx}{x} = x(\log x - 1) + C.$

Example 3. To find $\int \sqrt{a^2 + x^2} dx$.

Let $u = \sqrt{a^2 + x^2}, \quad dv = dx;$

then $du = \frac{x dx}{\sqrt{a^2 + x^2}}, \quad v = x,$

and $\int \sqrt{a^2 + x^2} dx = x \sqrt{a^2 + x^2} - \int \frac{x^2 dx}{\sqrt{a^2 + x^2}}.$

Again, $\sqrt{a^2 + x^2} = \frac{a^2 + x^2}{\sqrt{a^2 + x^2}},$

$$\int \sqrt{a^2 + x^2} dx = a^2 \int \frac{dx}{\sqrt{a^2 + x^2}} + \int \frac{x^2 dx}{\sqrt{a^2 + x^2}}.$$

Adding these two equations and recalling Ex. 5 in the preceding Exercises, we have:

$$(12) \int \sqrt{a^2 + x^2} dx = \frac{1}{2} [x \sqrt{a^2 + x^2} + a^2 \log (x + \sqrt{a^2 + x^2})] + C.$$

EXERCISES

Evaluate the following integrals:

$$1. \int x e^{ax} dx. \quad 5. \int x \cos ax dx. \quad 9. \int x \tan^{-1} x dx.$$

$$2. \int x^2 e^{ax} dx. \quad 6. \int \sin^{-1} x dx. \quad 10. \int x \log x dx.$$

$$3. \int x^3 e^{ax} dx. \quad 7. \int \tan^{-1} x dx. \quad 11. \int e^{ax} \sin x dx.$$

$$4. \int x \sin x dx. \quad 8. \int x \sin^{-1} x dx. \quad 12. \int e^{ax} \cos x dx.$$

$$13. \int \sqrt{x^2 - a^2} dx.$$

$$Ans. \frac{1}{2} [x \sqrt{x^2 - a^2} - a^2 \log (x + \sqrt{x^2 - a^2})] + C.$$

7. Use of the Tables. The integrals that ordinarily arise in practice and which can be evaluated in terms of the elementary functions can be found in such a table of integrals as Professor Peirce's,* and for this reason it is not necessary for us to go further into the theory of integration in this course. We have learned how to differentiate all the elementary functions, but not all these functions can be integrated in terms of the elementary functions. Thus the integral:

$$\int \frac{dx}{\sqrt{1+x^4}}, \quad \text{or} \quad \int \frac{d\phi}{\sqrt{1-k^2 \sin^2 \phi}}, \quad (0 < k^2 < 1),$$

* B. O. Peirce, *A Short Table of Integrals*, Revised Edition, 1899 or later, Ginn & Co., Boston.

leads to a new class of transcendental functions, the Elliptic Integrals, and cannot be evaluated in terms of algebraic functions, sines and cosines, etc.

There are, however, large classes of functions that can be integrated,* and the classes that are important in practice have been tabulated. The student is requested to examine with care the classification in the *Tables* above referred to.

Example 1. To find by aid of the *Tables* $\int \frac{x dx}{(1-x)^3}$.

The integrand is a rational function of x , and so we look under "II. Rational Algebraic Functions," p. 5. There we find "A. — Expressions Involving $a + bx$." Formula 31 gives us the integral we want:

$$\int \frac{x dx}{(1-x)^3} = -\frac{1}{1-x} + \frac{1}{2(1-x)^2} + C.$$

Example 2. To find $\int \frac{dx}{1+x+x^2}$.

Here the integrand involves rationally an expression of the form $X = a + bx + cx^2$, and so we look under C, p. 10. Two formulas, 67 and 68, give this integral. But since $q = 4ac - b^2 = 3$ is positive, the second formula would introduce imaginaries. The first gives:

$$\int \frac{dx}{1+x+x^2} = \frac{2}{\sqrt{3}} \tan^{-1} \frac{2x+1}{\sqrt{3}} + C.$$

Example 3. To find $\int \frac{dx}{\sqrt{1+x+x^2}}$.

Here the integrand involves \sqrt{X} , and so we look under "III. Irrational Algebraic Functions," and find under D, p. 23, Formulas 160, 161. Since $c = 1 > 0$, we choose No. 160:

* When we say, a function *can be integrated*, we mean, can be integrated *in terms of the elementary functions*. Every continuous function has an integral, for the area under its graph is an integral.

$$\int \frac{dx}{\sqrt{1+x+x^2}} = \log\left(\sqrt{1+x+x^2} + x + \frac{1}{2}\right) + C.$$

Example 4. To find $\int \sin^6 x \, dx$.

The integrand is a transcendental function. Turning to V, p. 35, and looking down the list we come to No. 263 :

$$\int \sin^n x \, dx = -\frac{\sin^{n-1} x \cos x}{n} + \frac{n-1}{n} \int \sin^{n-2} x \, dx.$$

If we set here $n=6$, we reduce the given integral to an expression involving $\int \sin^4 x \, dx$, and this integral can in turn be reduced by the same formula, written for $n=4$. Thus we get finally :

$$\int \sin^6 x \, dx = -\frac{\sin^5 x \cos x}{6} - \frac{5 \sin^3 x \cos x}{24} - \frac{5 \sin x \cos x}{16} + \frac{5x}{16} + C.$$

Example 5. To find $\int \frac{dx}{5-4 \cos x}$.

Formula 300 gives :

$$\int \frac{dx}{5-4 \cos x} = \frac{2}{3} \tan^{-1} \left[3 \tan \frac{x}{2} \right] + C.$$

EXERCISES

Evaluate the following integrals with the aid of the *Tables*.

$$1. \int \frac{x \, dx}{(4-5x)^2}. \quad \text{Ans. } \frac{1}{25} \left[\log(4-5x) + \frac{4}{4-5x} \right] + C.$$

$$2. \int \frac{dx}{x^2(1-x)}. \quad \text{Ans. } -\frac{1}{x} + \log \frac{x}{1-x} + C.$$

$$3. \int \frac{dx}{(x-2)(x-3)}. \quad 4. \int \frac{x \, dx}{x^2-5x+6}.$$

5. $\int \frac{dx}{5 + 3x^2}$. Ans. $\frac{1}{\sqrt{15}} \tan^{-1} \left(x \sqrt{\frac{3}{5}} \right) + C.$

6. $\int \frac{dx}{5 - 3x^2}$. 7. $\int \frac{x dx}{1 + x + x^2}$.

8. $\int \frac{dx}{x + x^2 + x^3}$. Ans. $\frac{1}{2} \log \frac{x^2}{1 + x + x^2} - \frac{1}{\sqrt{3}} \tan^{-1} \frac{2x + 1}{\sqrt{3}} + C.$

9. $\int \frac{\sqrt{1-x}}{x} dx$. Ans. $2\sqrt{1-x} + \log \frac{\sqrt{1-x}-1}{\sqrt{1-x}+1} + C.$

10. $\int \frac{dx}{x\sqrt{x-1}}$. 12. $\int \frac{\sqrt{x^2-5}}{x} dx.$

11. $\int \frac{dx}{x\sqrt{1+x^2}}$. 13. $\int \frac{\sqrt{1+4x^2}}{x} dx.$

14. $\int \sqrt{-1 + 4x - x^2} dx$. Ans. $\left(\frac{1}{2}x - 1\right) \sqrt{-1 + 4x - x^2} + \frac{3}{2} \sin^{-1} \frac{x-2}{\sqrt{3}} + C.$

15. $\int \frac{dx}{(7 - 9x + 2x^2)^{\frac{3}{2}}}$. 16. $\int \frac{dx}{x\sqrt{x^2 + px + q}}$.

17. $\int \frac{dx}{(1 - x^2)\sqrt{1 + x^2}}$. 18. $\int \sin^2 \theta \cos^2 \theta d\theta.$

8. Length of the Arc of a Curve. We have seen in Chap. V, § 6, that the differential of the arc of a curve is given by the formula:

$$ds = \sqrt{dx^2 + dy^2} = \sqrt{1 + \frac{dy^2}{dx^2}} dx.$$

Hence the length of the arc can be obtained by integration, and we have:

$$(13) \quad s = \int \sqrt{1 + \frac{dy^2}{dx^2}} dx.$$

Example 1. Let us find the length of the arc of the parabola :

$$y = x^2.$$

Here $dy = 2x dx$, $\sqrt{dx^2 + dy^2} = \sqrt{1 + 4x^2} dx$,

$$s = \int \sqrt{1 + 4x^2} dx,$$

and this integral can be reduced at once to (12) in § 6, or to Formula 124 of the *Tables* :

$$s = 2 \int \sqrt{\frac{1}{4} + x^2} dx = x \sqrt{\frac{1}{4} + x^2} + \frac{1}{4} \log(x + \sqrt{\frac{1}{4} + x^2}) + C.$$

If we measure the arc from the vertex, $s = 0$ when $x = 0$, and we have for the determination of C :

$$0 = \frac{1}{4} \log \frac{1}{2} + C, \quad C = \frac{1}{4} \log 2.$$

Hence $s = \frac{1}{2} x \sqrt{1 + 4x^2} + \frac{1}{4} \log(2x + \sqrt{1 + 4x^2})$.

In particular, the length of the arc to the point (1, 1) is

$$[s]_{x=1} = \frac{1}{2} \sqrt{5} + \frac{1}{4} \log(2 + \sqrt{5}).$$

On p. 111 of the *Tables* we find a table of natural logarithms, from which we see that

$$\log(2 + \sqrt{5}) = \log 4.24 = 1.45.$$

Hence $[s]_{x=1} = 1.48$.

As a check on this result we note that the length of the chord is $\sqrt{2} = 1.41$; on the other hand, the length of the broken line consisting of the abscissa and the ordinate of the point (1, 1) is 2. Consequently the length of the arc in question must lie between 1.41 and 2.

Example 2. To find the length of the arc of the equiangular spiral :

$$r = ae^{\lambda\theta}, \quad \lambda = \cot \alpha.$$

Here $ds = \sqrt{dr^2 + r^2 d\theta^2}$, $dr = \alpha \lambda e^{\lambda\theta} d\theta$,

$$\therefore ds = \sqrt{1 + \lambda^2} ae^{\lambda\theta} d\theta = \frac{\sqrt{1 + \lambda^2}}{\lambda} dr = dr \sec \alpha,$$

$$s = \sec \alpha \int dr = r \sec \alpha + k.$$

If we measure the arc from the point $\theta = 0, r = a$, then $s = 0$ when $r = a$ and

$$0 = a \sec \alpha + k. \quad \therefore s = (r - a) \sec \alpha.$$

When $\theta = -\infty$, the spiral coils round the pole $r = 0$ infinitely often, and r approaches 0 as its limit. The value of s , taken numerically, when $r < a$, is:

$$|s| = -s = (a - r) \sec \alpha.$$

Thus we see that the length of the spiral does not increase beyond all limit when $\theta = -\infty$, but

$$\lim_{\theta = -\infty} |s| = a \sec \alpha.$$

EXERCISES

- ✓ 1. Find the length of the cardioid:

$$r = a(1 - \cos \theta). \quad \text{Ans. } 8a.$$

2. Find the length of the spiral $r = \theta$ from the pole to the point where it crosses the prime vector for the first time, $\theta = 2\pi$.
Ans. 21.3.

- ✓ 3. Find the length of the arc of the curve $27y^2 = x^3$ included between the origin and the point whose abscissa is 15.
Ans. 19.

- ✓ 4. Find the length of the arc of the spiral $r = 1/\theta$, measured from the point $\theta = 1, r = 1$.

5. Prove that the length of the arc of the catenary:

$$y = \frac{a}{2} \left(e^{\frac{x}{a}} + e^{-\frac{x}{a}} \right),$$

measured from the vertex, $x = 0$, is: $s = \frac{a}{2} \left(e^{\frac{x}{a}} - e^{-\frac{x}{a}} \right).$

6. Assuming the equation of a parabola, referred to the focus as pole, in the form :

$$r = \frac{m}{1 - \cos \phi},$$

find the perimeter of the segment cut off by the latus rectum. Check your answer.

EXERCISES

Obtain the following integrals without the aid of the *Tables*.

- | | | |
|---|--|--|
| 1. $\int \sqrt{2mx} dx.$ | 9. $\int \frac{\log x dx}{x}$ | 17. $\int \frac{\sin x dx}{a + b \cos x}$ |
| 2. $\int \frac{dx}{\sqrt{1-x}}$ | 10. $\int \frac{t^2 + 1}{t-1} dt.$ | 18. $\int e^{\cos x} \sin x dx.$ |
| 3. $\int (a-x)^2 dx.$ | 11. $\int \frac{dx}{x \log x}$ | 19. $\int \sin^3 x dx.$ |
| 4. $\int (a^{\frac{2}{3}} - x^{\frac{2}{3}})^3 dx.$ | 12. $\int \frac{e^x - e^{-x}}{e^x + e^{-x}} dx.$ | 20. $\int \frac{dx}{e^x + e^{-x}}$ |
| 5. $\int \frac{x dx}{1-x^2}$ | 13. $\int 10^x dx.$ | 21. $\int \frac{\sin \theta d\theta}{\cos^2 \theta}$ |
| 6. $\int \frac{x^2 dx}{1+x}$ | 14. $\int (e^z - e^{-z})^2 dz.$ | 22. $\int \frac{dx}{1 + \sin x}$ |
| 7. $\int \frac{x-1}{x+1} dx.$ | 15. $\int \frac{(r^2-1)^2}{r^3} dr.$ | 23. $\int \sec^4 x dx.$ |
| 8. $\int \frac{x^{n-1} dx}{a + bx^n}$ | 16. $\int x \cos x^2 dx.$ | 24. $\int \cos^3 x dx.$ |

25. Let A denote the area bounded by the curve

$$r = f(\theta),$$

a fixed radius vector $\theta = \theta_0$, and a variable radius vector $\theta = \theta$, see Fig. 29. Show that

$$D_{\theta} A = \frac{1}{2} r^2,$$

and thus obtain the theorem :

$$(14) \quad A = \frac{1}{2} \int r^2 d\theta.$$

✓ 26. Find the area of the cardioid :

$$r = a(1 - \cos \phi). \quad \text{Ans. } \frac{3}{2} \pi a^2.$$

27. Determine the area cut out of the first quadrant by the arc of the equiangular spiral $r = ae^{\lambda\theta}$ corresponding to values of θ between 0 and $\frac{1}{2}\pi$.

28. Obtain the area of one lobe of the lemniscate :

$$r^2 = a^2 \cos 2\theta.$$

29. The same for $r = a \sin 3\theta$.

30. The same for $r = a \cos n\theta$.

✓ 31. Find the area of the ellipse :

$$\frac{x^2}{a^2} + \frac{y^2}{b^2} = 1. \quad \text{Ans. } \pi ab.$$

32. Prove that the length of the arc of the curve

$$y = a \log \frac{a^2}{a^2 - x^2},$$

measured from the origin, is

$$s = a \log \frac{a+x}{a-x} - x.$$

33. Prove that the length of the arc of the curve

$$8a^2y^2 = x^2(a^2 - x^2) \quad \text{is} \quad s = y + \frac{a}{\sqrt{2}} \sin^{-1} \frac{x}{a}.$$

✓ 34. Prove that the area of the curve

$$\left(y - \frac{x^2}{a}\right)^2 = a^2 - x^2 \quad \text{is} \quad \pi a^2.$$

✓ 35. Determine the area of the loop of the curve

$$y^2 = x^2 + x^3. \quad \text{Ans. } \frac{8}{15}$$

CHAPTER VII

CURVATURE. EVOLUTES

1. Curvature. We speak of a sharp curve on a railroad and thus express a qualitative characteristic of the curve. Let us see if we cannot get a quantitative determination of the degree of sharpness or flatness of curves in general.

If we consider the angle ϕ by which the tangent of a curve has changed direction when a point that traces out the curve

has moved from P to P' , then this angle will depend, not only on the sharpness of the curve, but also on the distance from P to P' . We can nearly eliminate this latter element

when P' is near P by taking the average change of angle per unit of arc, $\phi/\overline{PP'}$. This ratio we define as the average curvature :

$$\frac{\phi}{\overline{PP'}} = \text{average curvature for arc } PP'.$$

The limit approached by this average curvature is what we understand by the *curvature* at P ; it is denoted by κ :

$$(1) \quad \kappa = \lim_{P' \rightarrow P} \frac{\phi}{\overline{PP'}} = \text{actual curvature at } P.$$

Thus for a circle of radius a ,

$$\overline{PP'} = a\phi, \quad \frac{\phi}{\overline{PP'}} = \frac{1}{a}, \quad \lim_{P' \rightarrow P} \frac{\phi}{\overline{PP'}} = \frac{1}{a} = \kappa,$$

and the average curvature does not change with P' . The curvature of a circle is the same at all points and is equal to the reciprocal of the radius. Again, the curvature of a straight line is 0.

To evaluate the limit (1) for any curve, $y = f(x)$, we observe that, if we write

$$\widetilde{PP'} = \Delta s, \quad \phi = \Delta \tau,$$

then

$$\kappa = \lim_{\Delta s \rightarrow 0} \frac{\Delta \tau}{\Delta s} = D_s \tau,$$

where τ denotes as usual the angle which the tangent of the curve makes with the axis of x . More precisely, it is the numerical value of $D_s \tau$ which we want, for κ is an essentially positive quantity (or 0). Hence

$$(2) \quad \kappa = \pm \frac{d\tau}{ds}, \quad \text{or better:} \quad \kappa = \left| \frac{d\tau}{ds} \right|.$$

From the foregoing definition we see that the curvature is the rate at which the tangent turns when a point describes the curve with unit velocity.

To compute $d\tau/ds$ we have

$$(3) \quad \tan \tau = \frac{dy}{dx} \quad \text{or} \quad \tau = \tan^{-1} \frac{dy}{dx}.$$

It will be convenient to introduce a shorter notation for derivatives and we shall adopt Lagrange's, which employs accents:

$$y = f(x),$$

$$\frac{dy}{dx} = y' = f'(x), \quad \frac{d^2y}{dx^2} = y'' = f''(x), \quad \dots \quad \frac{d^ny}{dx^n} = y^{(n)} = f^{(n)}(x).$$

It follows, then, that

$$dy' = \frac{dy'}{dx} dx = \frac{d^2y}{dx^2} dx = y'' dx$$

and

$$ds = \sqrt{dx^2 + dy^2} = \sqrt{1 + y'^2} dx.$$

Returning to (3) and differentiating we have:

$$\tau = \tan^{-1} y', \quad d\tau = \frac{dy'}{1+y'^2} = \frac{y'' dx}{1+y'^2},$$

$$\frac{d\tau}{ds} = \frac{y''}{(1+y'^2)^{\frac{3}{2}}},$$

$$(4) \quad \kappa = \frac{|y''|}{(1+y'^2)^{\frac{3}{2}}} = \frac{\left| \frac{d^2y}{dx^2} \right|}{\left[1 + \frac{dy^2}{dx^2} \right]^{\frac{3}{2}}}.$$

The reciprocal of the curvature is called the *radius of curvature* and is usually denoted by ρ :*

$$(5) \quad \rho = \frac{1}{\kappa} = \frac{(1+y'^2)^{\frac{3}{2}}}{|y''|} = \frac{\left[1 + \frac{dy^2}{dx^2} \right]^{\frac{3}{2}}}{\left| \frac{d^2y}{dx^2} \right|}.$$

The radius of curvature of a circle is its radius. The curvature of a curve at a point of inflection is in general 0; for $y'' = 0$ at such a point if y'' is continuous there.

Example. To find the curvature of the parabola

$$y^2 = 2mx.$$

Here

$$2y dy = 2m dx, \quad y' = \frac{m}{y};$$

$$dy' = -\frac{m}{y^2} dy, \quad y'' = -\frac{m^2}{y^3};$$

$$\kappa = \frac{m^2 |y|^{-3}}{\left[1 + \frac{m^2}{y^2} \right]^{\frac{3}{2}}} = \frac{m^2}{(m^2 + y^2)^{\frac{3}{2}}}, \quad \rho = \frac{(m^2 + y^2)^{\frac{3}{2}}}{m^2}.$$

* The student can always recall which of these two ratios is the curvature, which the radius of curvature, by the check of *dimensions*. If we regard x and y each as of the first degree in length, then $y' = dy/dx$ is of the 0-th and $y'' = d^2y/dx^2$ of the -1st degree. Hence the bracket is of the 0-th degree and $|y''|$ of the -1st, and the ratio must therefore be written so as to yield ρ of the 1st, κ of the -1st degree in length.

EXERCISES

Find the curvature of each of the following curves.

✓ 1. $y = x^2$. *Ans.* $\kappa = \frac{2}{(1 + 4x^2)^{\frac{3}{2}}}$

✓ 2. $y = x^3$, at the origin.

✓ 3. $y = \log \csc x$. *Ans.* $\kappa = |\sin x|$

✓ 4. The ellipse: $\frac{x^2}{a^2} + \frac{y^2}{b^2} = 1$. *Ans.* $\kappa = \frac{a^4 b^4}{(b^4 x^2 + a^4 y^2)^{\frac{3}{2}}}$

5. The hyperbola: $\frac{x^2}{a^2} - \frac{y^2}{b^2} = 1$. *Ans.* $\kappa = \frac{a^4 b^4}{(b^4 x^2 + a^4 y^2)^{\frac{3}{2}}}$

✓ 6. The equilateral hyperbola: $xy = \frac{a^2}{2}$.
Ans. $\kappa = \frac{a^2}{(x^2 + y^2)^{\frac{3}{2}}}$

7. Show that the radius of curvature of the curve $y = x^{\frac{3}{2}}$ approaches 0 as its limit when the point P approaches the cusp, $(0, 0)$.

8. Find the radius of curvature of the curve

$$54y = 10x^5 - 19x^4 + 11x^3 + x^2 - 72x$$

at the origin.

Ans. $\rho = 125$.

9. Find the radius of curvature of the catenary

$$y = \frac{a}{2} \left(e^{\frac{x}{a}} + e^{-\frac{x}{a}} \right)$$

at the vertex.

Ans. $\rho = a$.

10. At what points of the curve $y = x^3$ is the curvature greatest?

11. Find the locus of the points in which the curvature of the curves of Fig. 4: $y = x^n$, $x > 0$, $n > 0$, is greatest.

Ans. $x = \left[\frac{n-2}{(2n-1)n^2} \right]^{\frac{1}{2n-2}}$, $y = \left[\frac{n-2}{(2n-1)n^2} \right]^{\frac{n}{2n-2}}$.

2. The Osculating Circle. At an arbitrary point P of a curve let the normal be drawn toward the concave side of the curve and let a distance be laid off on this normal equal to the radius of curvature, ρ . The point Q thus obtained is called the *centre of curvature*. The circle constructed with Q as centre and with radius ρ stands in an important relation to the curve. It is called the *osculating circle* and has the property that it represents the curve more accurately near P than any other circle does. Consider the family of circles drawn tangent to the curve at P and with their centres on the concave side. Those whose radii are very short are curved too sharply, — more sharply than the given curve. Now let the circles grow. If we pass to the other extreme of circles with very large radii, these will be too flat. Evidently, then, certain intermediate circles come nearer to the shape of the curve at P than these extreme ones do. It is not difficult to find a criterion by means of which one circle is characterized as better than all the others. Draw the tangent at P and drop a perpendicular from P' on it meeting it in M and cutting an arbitrary one of the circles in R . Then, as we shall show later, MP' will in general be an infinitesimal of the second order referred to the arc PP' as principal infinitesimal, and $P'R$ will also be of the second order for a circle taken at random. We can, however, in general find *one* circle for which $P'R$ will be an infinitesimal of the *third*

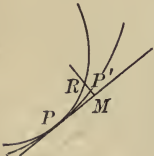

FIG. 37

order, and it turns out that this circle is precisely the osculating circle. We shall give the proof later (Chap. XIII, § 9).

The osculating circle cuts the curve in general at the point of tangency; but there may be certain exceptional points at which this is not the case. Near such a point $P'R$ is an infinitesimal of even higher order than the third, in general, of the fourth.

EXERCISE

Construct carefully the parabola $y = x^2$ for values of x : $-\frac{3}{4} < x < \frac{3}{4}$, taking 10 cm. as the unit. Draw the osculating

circle at the point $x = \frac{1}{2}$, $y = \frac{1}{4}$, and also at the vertex. Ink in the parabola in a fine black line, the first osculating circle in red, and the second in a different colored ink or in pencil.

3. The Evolute. When a point P traces out a curve, the centre of curvature Q traces out a second curve. This latter curve—the locus of Q —is called the *evolute* of the given curve. We proceed to deduce its equation and to discuss its properties.

The point Q can be found analytically by writing down the equation of the normal at P and determining the intersection of this line with a circle of radius ρ , having its centre at P . The equation of the normal is

$$(6) \quad X - x + y'(Y - y) = 0,$$

where (X, Y) are the running coordinates, *i.e.* the coordinates of a variable point on the normal, and (x, y) the coordinates of P ,—the latter being held fast during the following investigation. The equation of the circle is

$$(7) \quad (X - x)^2 + (Y - y)^2 = \rho^2 = \frac{(1 + y'^2)^3}{y''^2}.$$

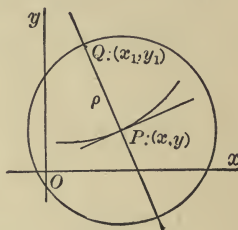

FIG. 38

To find where (6) and (7) intersect, eliminate X :

$$(1 + y'^2)(Y - y)^2 = \frac{(1 + y'^2)^3}{y''^2}, \quad Y - y = \pm \frac{1 + y'^2}{y''}.$$

Which sign must we take? Notice that when the curve is concave upward, as in the figure,

$$Y - y > 0 \quad \text{and} \quad y'' = \frac{d^2y}{dx^2} > 0.$$

Hence in this case we must use the upper sign:

$$(8) \quad Y - y = \frac{1 + y'^2}{y''}.$$

On the other hand, when the curve is concave downward,

$$Y - y < 0 \quad \text{and} \quad y'' = \frac{d^2y}{dx^2} < 0,$$

and again we have the upper sign. Hence (8) is always true and

$$Y = y + \frac{1 + y'^2}{y''}.$$

From (6) and (8) we get:

$$X = x - \frac{y'(1 + y'^2)}{y''}.$$

The values of X and Y thus found are the coordinates (x_1, y_1) of the point Q , and so we have:

$$(9) \quad x_1 = x - \frac{\frac{dy}{dx} \left(1 + \frac{dy^2}{dx^2} \right)}{\frac{d^2y}{dx^2}}, \quad y_1 = y + \frac{1 + \frac{dy^2}{dx^2}}{\frac{d^2y}{dx^2}}.$$

These formulas involve no radicals.

If we eliminate x and y between the two equations (9) and the equation $y = f(x)$ of the given curve, we shall obtain the equation of the evolute in the form

$$F(x_1, y_1) = 0.$$

But it is not necessary to eliminate. We can plot as many points on the evolute as we like by substituting in (9) the values of x, y, y' , and y'' corresponding to successive points on the given curve.

Example 1. To find the evolute of the parabola

$$(10) \quad y^2 = 2mx.$$

$$\text{Here,} \quad \frac{dy}{dx} = \frac{m}{y}, \quad 1 + \frac{dy^2}{dx^2} = \frac{m^2 + y^2}{y^2}, \quad \frac{d^2y}{dx^2} = -\frac{m^2}{y^3}.$$

$$\text{Hence} \quad x_1 = x - \frac{m(m^2 + y^2)}{y^3} \Big/ -\frac{m^2}{y^3} = x + \frac{m^2 + y^2}{m},$$

$$y_1 = y + \frac{m^2 + y^2}{y^2} / - \frac{m^2}{y^3} = - \frac{y^3}{m^2},$$

and it remains to eliminate x and y between these equations and (10). Eliminating x we have :

$$x_1 = \frac{y^2}{2m} + \frac{m^2 + y^2}{m} = m + \frac{3y^2}{2m}$$

or
$$\frac{2m}{3}(x_1 - m) = y^2.$$

From the second equation :

$$- m^2 y_1 = y^3.$$

To eliminate y between these last two equations, square each side of the last and cube each side of the preceding one. Thus we get :

$$m^4 y_1^2 = \frac{8m^3}{27} (x_1 - m)^3.$$

Dropping the subscripts we have as the equation of the evolute of the parabola :

$$(11) \quad y^2 = \frac{8}{27m} (x - m)^3.$$

This is a so-called *semi-cubical parabola*.

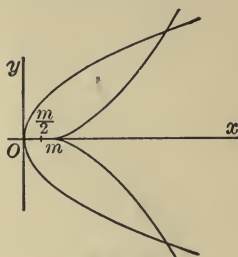

FIG. 39

Example 2. To find the evolute of the ellipse

$$(12) \quad \frac{x^2}{a^2} + \frac{y^2}{b^2} = 1.$$

We obtain without difficulty the equations :

$$\frac{dy}{dx} = - \frac{b^2 x}{a^2 y}, \quad \frac{d^2 y}{dx^2} = - \frac{b^4}{a^2 y^3},$$

$$x_1 = x - \frac{x(b^4 x^2 + a^4 y^2)}{a^4 b^2}, \quad y_1 = y - \frac{y(b^4 x^2 + a^4 y^2)}{a^2 b^4}.$$

To eliminate x and y between these equations and (12) requires a little ingenuity. From (12) we have

$$b^2x^2 + a^2y^2 = a^2b^2, \quad a^4y^2 = a^2b^2(a^2 - x^2),$$

$$b^4x^2 + a^4y^2 = b^2(a^4 - a^2x^2 + b^2x^2).$$

Hence
$$x_1 = x - \frac{b^2x(a^4 - a^2x^2 + b^2x^2)}{a^4b^2} = \frac{a^2 - b^2}{a^4}x^3.$$

In a similar manner we get :

$$y_1 = y - \frac{a^2y(b^4 - b^2y^2 + a^2y^2)}{a^2b^4} = -\frac{a^2 - b^2}{b^4}y^3.$$

We can solve these equations respectively for x^2 and y^2 and substitute the values thus obtained in (12):

$$\left(\frac{ax_1}{a^2 - b^2}\right)^{\frac{2}{3}} + \left(\frac{by_1}{a^2 - b^2}\right)^{\frac{2}{3}} = 1.$$

Dropping the accents we have as the final equation of the evolute of the ellipse:

$$(13) \quad (ax)^{\frac{2}{3}} + (by)^{\frac{2}{3}} = (a^2 - b^2)^{\frac{2}{3}}.$$

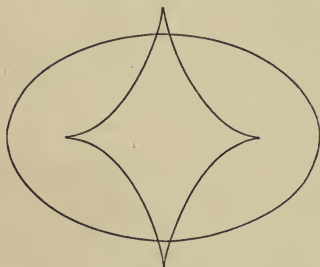

FIG. 40

EXERCISES

Find the equation of the evolute of each of the following curves.

1. The hyperbola: $\frac{x^2}{a^2} - \frac{y^2}{b^2} = 1.$

Ans. $(ax)^{\frac{2}{3}} - (by)^{\frac{2}{3}} = (a^2 + b^2)^{\frac{2}{3}}.$

2. The hyperbola: $2xy = a^2.$

Ans. $(x+y)^{\frac{2}{3}} - (x-y)^{\frac{2}{3}} = 2a^{\frac{2}{3}}.$

3. The catenary: $y = \frac{1}{2}(e^x + e^{-x}).$

Ans. $x_1 = x - \frac{1}{4}(e^{2x} - e^{-2x}), \quad y_1 = 2y;$

$$x = \log \left[\frac{y}{2} \pm \sqrt{\frac{y^2}{4} - 1} \right] \mp \frac{y}{2} \sqrt{\frac{y^2}{4} - 1}.$$

4. $x^{\frac{2}{3}} + y^{\frac{2}{3}} = a^{\frac{2}{3}}.$

Ans. $(x+y)^{\frac{2}{3}} + (x-y)^{\frac{2}{3}} = 2a^{\frac{2}{3}}.$

5. $x = a(\cos \theta + \theta \sin \theta)$, *Ans.* $x^2 + y^2 = a^2$.
 $y = a(\sin \theta - \theta \cos \theta)$.
6. $x = a \cos^3 \theta$, $y = a \sin^3 \theta$. *Ans.* $(x + y)^{\frac{2}{3}} + (x - y)^{\frac{2}{3}} = 2a^{\frac{2}{3}}$.

4. Properties of the Evolute. The property of the evolute to which the curve owes its name is the following. Suppose a material cylinder to be constructed on the concave side of the evolute and a string to be wound on the cylinder, Fig. 41. Let a pencil be fastened to the end of the string, the point being placed at a point P_0 of the given curve and the string drawn taut and fastened at a point A of the evolute so that it cannot slip. If now the pencil is moved along the paper so that the string unwinds from the evolute or winds up, the pencil will describe the given curve.

To prove this, let P be an arbitrary point of the given curve, Q the corresponding point of the evolute, and P' the position of the pencil when the string leaves the evolute at Q . We wish to prove that P' coincides with P . To do this it is sufficient to show (a) that QP is tangent to the evolute, so that P' lies on QP ; and (b) that $QP' = QP = \rho$.

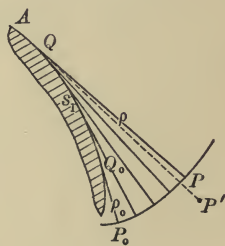

FIG. 41

ad (a) Writing equations (9) in the form :

$$x_1 = x - \frac{y'(1 + y'^2)}{y''}, \quad y_1 = y + \frac{1 + y'^2}{y''}$$

and differentiating with respect to x , we have :*

$$\frac{dx_1}{dx} = x_1' = \frac{y'(1 + y'^2)y'''}{y''^2} - 3y'^2 = \frac{y'(1 + y'^2)y''' - 3y'^2y''^2}{y''^2},$$

$$\frac{dy_1}{dx} = y_1' = 3y' - (1 + y'^2) \frac{y'''}{y''^2} = \frac{3y'y''^2 - (1 + y'^2)y'''}{y''^2},$$

* The student may find it more convenient in working out these differentiations to retain the form (9). Lagrange's form is more compact.

$$\therefore \frac{dy_1}{dx_1} = -\frac{1}{y'} = -\frac{1}{\frac{dy}{dx}},$$

and thus the slope of the evolute at Q is seen to be the negative reciprocal of the slope of the given curve at P . Hence QP is tangent to the evolute, q. e. d.

ad (b) If we denote by s_1 the length of the arc Q_0Q of the evolute, then $\rho = s_1 + \rho_0$, and we wish to show that this quantity is equal to ρ :

$$s_1 + \rho_0 = \rho.$$

It is evidently sufficient to show that

$$\frac{ds_1}{dx} = \frac{d\rho}{dx}.$$

Now

$$ds_1^2 = dx_1^2 + dy_1^2,$$

$$\frac{ds_1^2}{dx^2} = x_1'^2 + y_1'^2 = y_1'^2 \left(1 + \frac{x_1'^2}{y_1'^2} \right) = y_1'^2 (1 + y'^2).$$

And again:

$$\frac{d\rho}{dx} = \pm \frac{3y'y''^2 - (1 + y'^2)y'''}{y''^2} \sqrt{1 + y'^2} = \pm y_1' \sqrt{1 + y'^2}.$$

Hence

$$\frac{ds_1}{dx} = \pm \frac{d\rho}{dx},$$

and since we have taken s_1 so that it increases when ρ increases, the upper sign holds:

$$ds_1 = d\rho, \quad s_1 = \rho + C.$$

At Q_0 , $s_1 = 0$ and $\rho = \rho_0$, hence $0 = \rho_0 + C$,
and

$$\rho = s_1 + \rho_0, \quad \text{q. e. d.}$$

We have shown incidentally that the normals to the given curve are tangent to the evolute. Thus it appears that the evolute is the envelope of the normals of the given curve. This property can be used as the definition of the evolute and its equation is then readily deduced by the method of Chap. XVII.

EXERCISES

1. If the equation of the curve is given in polar coordinates, $r = f(\theta)$, then (see Fig. 29)

$$\Delta r = \Delta \psi + \Delta \theta$$

and hence

$$\frac{dr}{ds} = \frac{d\psi}{ds} + \frac{d\theta}{ds}.$$

Remembering that

$$\tan \psi = r \frac{d\theta}{dr} = \frac{r}{r'},$$

where $r' = dr/d\theta$, obtain the formula,

$$(14) \quad \rho = \pm \frac{\left[r^2 + \frac{dr^2}{d\theta^2} \right]^{\frac{3}{2}}}{r^2 - r \frac{d^2 r}{d\theta^2} + 2 \frac{dr^2}{d\theta^2}}.$$

Find the radius of curvature of each of the following curves at any point.

2. The spiral of Archimedes $r = a\theta$. Ans. $\rho = \frac{(r^2 + a^2)^{\frac{3}{2}}}{r^2 + 2a^2}$.

3. The cardioid $r = 2a(1 - \cos \phi)$. Ans. $\rho = \frac{4}{3} \sqrt{ar}$.

4. The lemniscate $r^2 = a^2 \cos 2\theta$. Ans. $\rho = \frac{a^2}{3r}$.

5. The equilateral hyperbola $r^2 \cos 2\theta = a^2$. Ans. $\rho = \frac{r^3}{a^2}$.

6. The equiangular spiral $r = ae^{\lambda\theta}$.

7. The trisectrix $r = 2a \cos \theta - a$.

Ans. $\rho = \frac{a(5 - 4 \cos \theta)^{\frac{3}{2}}}{9 - 6 \cos \theta}$.

CHAPTER VIII

THE CYCLOID

1. The Equations of the Cycloid. The cycloid is the path traced out by a point in the rim of a wheel as it rolls, *i.e.* by a point in the circumference of a circle which rolls without slipping on a straight line, always remaining in the same plane. Let the given line be taken as the axis of x and let θ be the angle through which the circle has turned since the point P was last in contact with the line at O . The coordinates of P ,

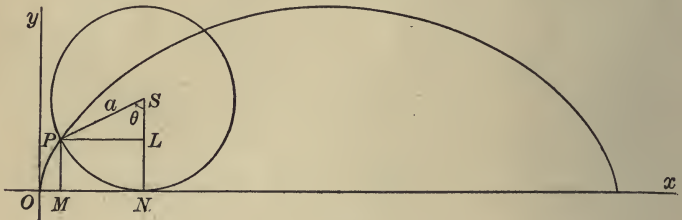

FIG. 42

$x = OM$ and $y = MP$, can be expressed as follows in terms of θ . We notice that the arc $NP = a\theta$ of the circle and the segment ON of the line are of equal length, since the circle rolls without slipping. Hence

$$OM = ON - MN = a\theta - a \sin \theta.$$

Also, $MP = NS - LS = a - a \cos \theta$;

and so we have:

$$(1) \quad \begin{cases} x = a(\theta - \sin \theta), \\ y = a(1 - \cos \theta), \end{cases}$$

as the equations of the cycloid.

It is possible to eliminate θ between these equations and thus obtain a single equation between x and y . But the functions thus introduced are less simple than those of equations (1) and it is more convenient to discuss the properties of the curve directly by means of these equations.

EXERCISES

1. The equations of the cycloid referred to parallel axes with the new origin at the vertex, *i.e.* the highest point, are:

$$(2) \quad \begin{cases} x = a\theta + a \sin \theta, \\ y = -a + a \cos \theta, \end{cases}$$

the angle θ now being the angle through which the circle has turned since the point P was at the vertex. Obtain these equations geometrically, drawing first the requisite figure, and verify the result analytically by transforming the equations (1):

$$x = x' + \pi a, \quad y = y' + 2a, \quad \theta = \theta' + \pi.$$

2. Show that the equations of an inverted cycloid referred to the vertex as origin can be written in the form:

$$(3) \quad \begin{cases} x = a\theta + a \sin \theta, \\ y = a - a \cos \theta. \end{cases}$$

Draw the figure and interpret θ geometrically.

2. Properties of the Cycloid. The slope of the curve is

$$\frac{dy}{dx} = \frac{a \sin \theta d\theta}{a d\theta - a \cos \theta d\theta} = \frac{\sin \theta}{1 - \cos \theta} = \frac{2 \sin \frac{1}{2} \theta \cos \frac{1}{2} \theta}{2 \sin^2 \frac{1}{2} \theta} = \cot \frac{1}{2} \theta,$$

or $\tan \tau = \cot \frac{1}{2} \theta.$

From this result we infer that the tangent at P is perpendicular to the chord PN , Fig. 43. For the latter makes an angle of $\frac{1}{2} \theta$ with the negative axis of x and hence its slope is $-\tan \frac{1}{2} \theta$, *i.e.* the negative reciprocal of the slope of the tangent. Thus we see that the normal at P goes through the

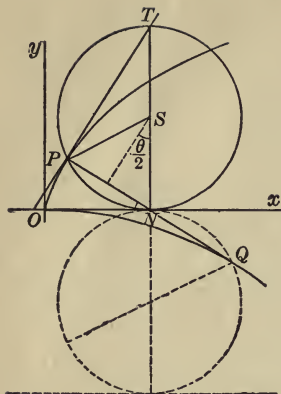

FIG. 43

lowest point of the generating circle and hence the tangent at P goes through the highest point.

The equation of the tangent at the point (x_0, y_0) , $\theta = \theta_0$, is

$$(4) \quad y - y_0 = \cot \frac{1}{2} \theta_0 (x - x_0),$$

and of the normal :

$$(5) \quad x - x_0 + \cot \frac{1}{2} \theta_0 (y - y_0) = 0.$$

The Evolute. We have seen that

$$\frac{dy}{dx} = \cot \frac{1}{2} \theta. \quad \text{Hence } 1 + \frac{dy^2}{dx^2} = \csc^2 \frac{1}{2} \theta$$

and

$$\frac{d^2y}{dx^2} = \frac{d \frac{dy}{dx}}{dx} = \frac{-\frac{1}{2} \csc^2 \frac{1}{2} \theta d\theta}{a d\theta - a \cos \theta d\theta} = -\frac{1}{4a \sin^4 \frac{1}{2} \theta},$$

$$(6) \quad \rho = \frac{4a \sin^4 \frac{1}{2} \theta}{\sin^3 \frac{1}{2} \theta} = 4a \sin \frac{1}{2} \theta.$$

It is now easy to construct the centre of curvature and thus find the evolute. We have merely to lay off on the normal PN a distance $PQ = 4a \sin \frac{1}{2} \theta$, *i.e.* double the distance PN . The locus of the point Q is thus seen to be an equal cycloid having its vertex at the origin O . We leave the proof, which is simple, to the student, referring him to Fig. 43.



FIG. 44

The Arc. We have :

$$ds^2 = dx^2 + dy^2 = a^2 [(1 - \cos \theta)^2 + \sin^2 \theta] d\theta^2 = 4a^2 \sin^2 \frac{1}{2} \theta d\theta^2,$$

$$s = 2a \int \sin \frac{1}{2} \theta d\theta = 4a \int \sin \frac{1}{2} \theta d(\frac{1}{2} \theta) = -4a \cos \frac{1}{2} \theta + C.$$

Furthermore, the arc $AN = a\theta$ and the arc $NP = b\phi$ are equal: $a\theta = b\phi$. Hence we have as the equations of the epicycloid:

$$(9) \quad \begin{cases} x = (a + b) \cos \theta - b \cos \frac{a+b}{b} \theta, \\ y = (a + b) \sin \theta - b \sin \frac{a+b}{b} \theta. \end{cases}$$

If the variable circle rolls on the inside of the fixed circle, the path of the point P is a *hypocycloid*. Its equations are obtained in a similar manner and are:

$$(10) \quad \begin{cases} x = (a - b) \cos \theta + b \cos \frac{a-b}{b} \theta, \\ y = (a - b) \sin \theta - b \sin \frac{a-b}{b} \theta. \end{cases}$$

The following special cases are of interest.

(1) If $a = 2b$, the hypocycloid reduces to a segment of a straight line, namely, the diameter of the circle, $y = 0$. Thus a journal on the rim of a toothed wheel which meshes internally with another wheel of twice the diameter describes a right line, so that circular motion is thereby converted into rectilinear motion.

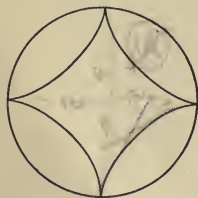

FIG. 46

(2) When $a = 4b$, the equations of the hypocycloid reduce to the following (cf. *Tables*, Formulas 580 and 585):

$$\begin{cases} x = 3b \cos \theta + b \cos 3\theta = a \cos^3 \theta, \\ y = 3b \sin \theta - b \sin 3\theta = a \sin^3 \theta. \end{cases}$$

Hence $x^{\frac{2}{3}} + y^{\frac{2}{3}} = a^{\frac{2}{3}}$.

This is the equation of the *four-cusped hypocycloid*.

The cycloids play an important part in Applied Mechanics, in the theory of the shape in which the teeth of gears should be cut.

For a more extensive discussion of the subject of this chapter see Williamson, *Differential Calculus*, Chap. XIX, Roulettes.

EXERCISES

1. Show by means of the equation of the normal of the cycloid, (5), that the normal goes through the lowest point of the generating circle.

2. Obtain the equations of the path of the journal of the driver of a locomotive and plot the curve.

3. Obtain the equations of the path of a point on the outer edge of the flange of a driver.

4. Obtain the equations of the path of the pedal of a bicycle.

5. Obtain the equation of the path of an arbitrary point in the wheels of a sidewheel steamboat.

The curves of Exs. 2-5 are called *trochoids*.

6. Find the velocity, v , of the point that generates a cycloid.

Ans. $v = 2a\omega \sin \frac{1}{2}\theta = 2V \sin \frac{1}{2}\theta$, where ω is the angular velocity of the wheel and V the linear velocity of the hub. At the vertex $v = 2V$, *i.e.* the velocity of the highest point of the wheel is twice that of the hub.

7. Find the area included between an arch of the cycloid and its evolute. *Ans.* $4\pi a^2$.

8. Show that the length of the arc of an inverted cycloid (3), measured from the vertex is

$$s = 4a \sin \tau.$$

9. Obtain the equations of the evolute of the cycloid analytically, by means of equations (9) in Chap. VII.

10. At what points is the trochoid

$$x = a\theta - b \sin \theta, \quad y = a - b \cos \theta, \quad (b < a)$$

steepest?

Ans. When $\cos \theta = \frac{b}{a}$.

11. Find the area under one arch of the trochoid of question 10. *Ans.* $2\pi a^2 + \pi b^2$.

12. The epicycloid for which $b = a$ is a cardioid :

$$r = 2a(1 - \cos \phi),$$

the cusp being taken as the pole. Obtain this result from equations (9).

13. Obtain the result in question 12 directly geometrically.

14. Prove by elementary geometry that the hypocycloid for which $b = \frac{1}{2}a$ is a straight line.

15. Show that the equation of the normal of the hypocycloid is :

$$(\sin \theta_0 + \sin \frac{a-b}{b}\theta_0)(x - x_0) = (\cos \theta_0 - \cos \frac{a-b}{b}\theta_0)(y - y_0).$$

16. Prove that the normal of the hypocycloid passes through the point of contact of the rolling circle.

17. Work out questions 15 and 16 for the epicycloid.

18. Show that the hypocycloid for which $b = \frac{1}{3}a$ and that for which $b = \frac{2}{3}a$ are the same curve.

19. Show that the length of the four-cusped hypocycloid is three times the diameter of the fixed circle.

20. Find the area of the four-cusped hypocycloid.

$$\text{Ans. } \frac{3\pi a^2}{8}.$$

21. Find the area enclosed between one arch of a four-cusped epicycloid and the fixed circle.

$$\text{Ans. } \frac{7\pi a^2}{32}.$$

22. Obtain the equations of the epitrochoid.

23. Obtain the equations of the hypotrochoid.

24. How many revolutions does the rolling circle make in tracing out a cardioid? a four-cusped hypocycloid? How many revolutions does the moon make in a lunar month?

25. How many cusps does an epicycloid have when a and b are commensurable: $a/b = p/q$? What can you say about this curve when a and b are incommensurable?

CHAPTER IX

DEFINITE INTEGRALS

1. **A New Expression for the Area under a Curve.** In Chap. VI we learned how to compute the area A under a continuous curve, $y = f(x)$, by integration. We found that

$$D_x A = y, \quad A = \int y dx + C,$$

and hence finally:

$$(1) \quad A = \left[\int y dx \right]_{x=b} - \left[\int y dx \right]_{x=a} = \left[\int y dx \right]_{x=a}^{x=b}.$$

We will now consider a new method of computing the same area. Let the interval (a, b) of the axis of x : $a \leq x \leq b$, be divided into n equal parts and let ordinates be erected at each of the points of division. Let rectangles be constructed on these subintervals with altitudes equal to the ordinate that forms their left-hand boundary. Then it is obvious that the sum of the areas of these rectangles will be approximately equal to the area A in question, and will approach A as its limit when n is allowed to increase without limit. A formal proof will be found at the end of this chapter.

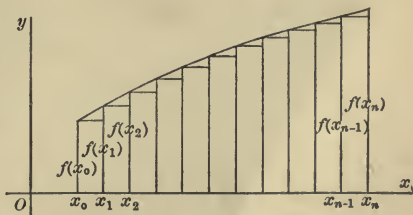

FIG. 47

We will next formulate analytically the above sum. The area of the first rectangle is

$$f(a)\Delta x \quad \text{or} \quad f(x_0)\Delta x,$$

where Δx denotes the length of the base, $x_1 - x_0 = (b - a)/n$. The area of the second rectangle is $f(x_1)\Delta x$, and so on. Hence the sum of these areas is

$$(2) \quad f(x_0)\Delta x + f(x_1)\Delta x + \cdots + f(x_{n-1})\Delta x,$$

and thus, allowing n to increase without limit, we obtain the result:

$$(3) \quad A = \lim_{n \rightarrow \infty} [f(x_0)\Delta x + f(x_1)\Delta x + \cdots + f(x_{n-1})\Delta x].$$

Example. Let

$$y = f(x) = \sin x,$$

and let the interval (a, b) be the interval $0 \leq x \leq \pi/2$. Take $n = 10$. Then $\Delta x = 3.14/20 = .157$, and we have to compute

$$\sin 0^\circ \Delta x + \sin 9^\circ \Delta x + \cdots + \sin 81^\circ \Delta x.$$

Here

sin $0^\circ = .000$	sin $45^\circ = .707$
sin $9^\circ = .156$	sin $54^\circ = .809$
sin $18^\circ = .309$	sin $63^\circ = .891$
sin $27^\circ = .454$	sin $72^\circ = .951$
sin $36^\circ = .588$	sin $81^\circ = .988$
<u>1.507</u>	<u>4.346</u>

and thus we obtain

$$5.853 \times .157 = .92.$$

2. The Fundamental Theorem of the Integral Calculus.

Equating the two values of A found in § 1 to each other, we obtain

$$(4) \quad \lim_{n \rightarrow \infty} [f(x_0)\Delta x + f(x_1)\Delta x + \cdots + f(x_{n-1})\Delta x] = \left[\int f(x) dx \right]_{x=a}^{x=b}$$

Although the formulas (1) and (3) were deduced from geometrical considerations, the final result (4) is purely analytic in

its character. We may liken the process to that of building a masonry bridge. First a wooden arch is erected. On this are placed the blocks of granite, and when the structure is completed the wooden arch is removed. The bridge is the essential thing, the wood was incidental. And so here the geometrical pictures are but a means to the end, which is an analytical theorem,—the theorem on which the integral calculus rests. Let us state the result in words.

FUNDAMENTAL THEOREM OF THE INTEGRAL CALCULUS. *Let $f(x)$ be a continuous function of x throughout the interval $a \leq x \leq b$. Divide this interval into n equal parts by the points $x_0 = a, x_1, x_2, \dots, x_{n-1}, x_n = b$, and form the sum:*

$$f(x_0)\Delta x + f(x_1)\Delta x + \dots + f(x_{n-1})\Delta x.$$

If n now be allowed to increase without limit, this sum will approach a limit; and this limit can be found by integrating the function $f(x)$ and taking the integral between the limits $x = a$ and $x = b$:

$$\left[\int f(x) dx \right]_{x=a}^{x=b}.$$

Expressed as a formula, the theorem is as follows:

$$\lim_{n=\infty} \left[f(x_0)\Delta x + f(x_1)\Delta x + \dots + f(x_{n-1})\Delta x \right] = \left[\int f(x) dx \right]_{x=a}^{x=b}.$$

Instead of choosing the altitudes of the rectangles in § 1 as the left-hand ordinates, we might equally well have taken the right-hand ordinates. We should then have in place of (3):

$$(5) \quad A = \lim_{n=\infty} \left[f(x_1)\Delta x + f(x_2)\Delta x + \dots + f(x_n)\Delta x \right],$$

and hence in place of (4):

$$(6) \quad \lim_{n=\infty} \left[f(x_1)\Delta x + f(x_2)\Delta x + \dots + f(x_n)\Delta x \right] = \left[\int f(x) dx \right]_{x=a}^{x=b}.$$

In fact, we might even choose intermediate ordinates for these altitudes if we wished.

Again, it is not necessary to take the subintervals (x_0, x_1) , (x_1, x_2) , \dots all equal. Their lengths $\Delta x_0, \Delta x_1, \dots$ are arbitrary. But in that case the longest of these must converge toward 0 when n increases indefinitely.

Finally, a definition. The limit of the sum (3) or (5) is called the *definite integral* of the function $f(x)$, and is denoted by

$$\int_a^b f(x) dx.$$

In distinction from the definite integral, which is the limit of a sum, that which we have hitherto called an integral, namely the inverse of a derivative, is called an *indefinite integral*.

The integral sign had its origin in the old-fashioned long s , the initial letter of *summa*, the integral being thus conceived as a definite integral, the limit of a sum.

Such a sum as the one that enters in (2) or (5) is frequently written in the form:

$$\sum_{k=0}^{n-1} f(x_k) \Delta x \quad \text{resp.} \quad \sum_{k=1}^n f(x_k) \Delta x.$$

EXERCISES

1. Write out the sum (2) for the interval $0 \leq x \leq 1$ when

$$f(x) = \frac{1}{1+x^2} \quad \text{and} \quad \Delta x = .1,$$

and compute its value. Determine the limit of the sum (2) for this function by means of the indefinite integral.

2. Taking as the interval $0 \leq x \leq \frac{1}{2}$ and letting

$$f(x) = \frac{1}{\sqrt{1-x^2}}, \quad \Delta x = .05,$$

compute

$$\sum_{k=0}^9 \frac{\Delta x}{\sqrt{1-x_k^2}}, \quad \sum_{k=1}^{10} \frac{\Delta x}{\sqrt{1-x_k^2}}.$$

Determine the limit of the corresponding sums when Δx approaches 0, and show by a figure that this limit lies between the two sums just computed.

3. Volume of a Solid of Revolution. If a plane curve rotates about an axis lying in its plane, it generates the surface of a solid of revolution. Let us determine the volume of such a solid, its bases being planes perpendicular to the axis.

Take the axis of revolution as the axis of abscissas and divide the portion of the axis that lies between the bases into n equal parts by the points $x_0 = a, x_1, \dots, x_{n-1}, x_n = b$. Pass planes through these points of division perpendicular to the axis, thus dividing the solid up into slabs. We can approximate to the volumes of these slabs by means of cylinders whose bases are the successive cross-sections. The volume of the k -th cylinder is

$$\pi y_k^2 \Delta x,$$

and the volume of the solid in question is thus seen to be the limit of the sum of the volumes of these cylinders:

$$V = \lim_{n \rightarrow \infty} \left[\pi y_0^2 \Delta x + \pi y_1^2 \Delta x + \dots + \pi y_{n-1}^2 \Delta x \right],$$

i.e.

$$(7) \quad V = \pi \int_a^b y^2 dx,$$

where $y = \phi(x)$ is the equation of the generating curve.

For example, let it be required to find the volume of a segment of a sphere. Here the generating curve is a circle,

$$x^2 + y^2 = r^2,$$

and, h denoting the altitude of the segment, the abscissas of the bases are $r - h$ and r . Hence

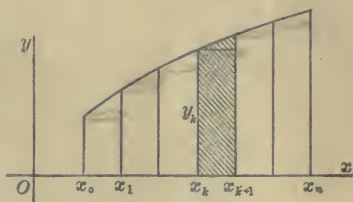

FIG. 48

$$V = \pi \int_{r-h}^r (r^2 - x^2) dx = \pi \left[r^2 x - \frac{x^3}{3} \right]_{r-h}^r = \frac{\pi}{3} (3r - h) h^2.$$

If, in particular, $h = -r$, we have the complete sphere and obtain the familiar result $\frac{4}{3}\pi r^3$.

EXERCISES

1. Show that the volume of an ellipsoid of revolution is $\frac{4}{3}\pi ab^2$, where a denotes the half-length of the axis.

2. A spindle is formed by the rotation of an arch of the curve

$$y = \sin x$$

about its base. Find its volume.

Ans. 4.93480.

3. Show that the volume of a cone is $\frac{1}{3}\pi r^2 h$, and that the volume of a frustum is

$$\frac{\pi h}{3} (r^2 + rR + R^2).$$

4. Show that the volume of a segment of a paraboloid of revolution, of arbitrary altitude, is one-half that of the circumscribing cylinder.

5. A cycloid revolves about its base. Show that the volume of the solid generated is $5\pi^2 a^3$.

6. The four-cusped hypocycloid

$$x^{\frac{2}{3}} + y^{\frac{2}{3}} = a^{\frac{2}{3}}$$

rotates about the axis of x . Find the volume of the solid generated.

Ans. $\frac{32\pi a^3}{105}$.

7. Find the volume of a segment of the solid of revolution generated by the catenary:

$$y = \frac{1}{2}(e^x + e^{-x}),$$

when it rotates about the axis of x , the plane $x=0$ forming one of the bases.

Ans. $\frac{\pi}{8}(e^{2h} - e^{-2h} + 4h)$.

4. Other Volumes. We will begin with the following example. A wood-cutter starts to fell a tree 4 ft. in diameter and cuts half way through. One face of the cut is horizontal, and the other face is inclined to the horizontal at an angle of 45° . How much of the wood is lost in chips?

Since the solid whose volume we wish to compute is symmetric, we may confine ourselves to the portion $OABC$. Divide the edge OA into n equal parts and pass planes through these points of division perpendicular to OA . The solid is thus divided into slabs that are nearly prisms; only the face $QRR'Q'$ is not a plane. Let us meet this difficulty by constructing a right prism on PQR as base and with PP' as altitude. Then its volume will be a little greater than that of the actual slab.

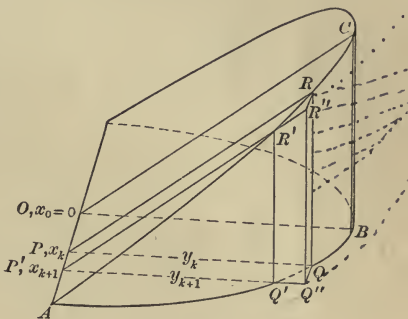

FIG. 49

The solid formed by the n prisms thus constructed differs in volume but slightly from the actual solid.*

We will next formulate analytically the volume of the prisms. The base PQR is a 45° right triangle. Let $OP = x_k$ and $PQ = y_k$. Then, by the Pythagorean Theorem,

$$x_k^2 + y_k^2 = 4.$$

Hence the volume of this prism is

$$\frac{1}{2} y_k^2 \Delta x = \frac{1}{2} (4 - x_k^2) \Delta x,$$

* Let the student not proceed further till this point is perfectly clear to him. Let him make a model of the actual solid out of cardboard or a piece of wood and draw neatly the lines in which the plane sections through P and P' perpendicular to OA cut the solid. He will then be able to visualize the auxiliary prisms without difficulty and to perceive that the sum of their volumes approaches as its limit the volume to be computed.

and the volume of the solid we wish to compute is

$$(8) \quad \lim_{n \rightarrow \infty} \left[\frac{1}{2}(4 - x_0^2) \Delta x + \frac{1}{2}(4 - x_1^2) \Delta x + \cdots + \frac{1}{2}(4 - x_{n-1}^2) \Delta x \right].$$

The problem before us is thus reduced to that of computing the limit (8). Now inspection of this limit shows that it is of the same type as the limit (3) of § 1; in fact, the two variables become identical if we put

$$f(x) = \frac{1}{2}(4 - x^2).$$

Hence the limit (8) can be computed by integrating the function $\frac{1}{2}(4 - x^2)$ and taking the integral between the limits $x = a = 0$ and $x = b = 2$:

$$\int \frac{1}{2}(4 - x^2) dx = 2x - \frac{x^3}{6},$$

$$\left[\int \frac{1}{2}(4 - x^2) dx \right]_{x=0}^{x=2} = \left[2x - \frac{x^3}{6} \right]_{x=2} - \left[2x - \frac{x^3}{6} \right]_{x=0} = 2\frac{2}{3}.$$

The total volume is twice this amount, and thus it appears that there were $5\frac{1}{3}$ cu. ft. of chips hewn out.

EXERCISES

1. A banister cap is bounded by two equal cylinders of revolution whose axes intersect at right angles in the plane of the base of the cap. Find the volume of the cap. *Ans.* $\frac{8}{3}a^3$.

2. A Rugby foot-ball is 16 in. long, and a plane section containing a seam of the cover is an ellipse 8 in. broad. Find the volume of the ball, assuming that the leather is so stiff that every plane cross-section is a square. *Ans.* $341\frac{1}{3}$ cu. in.

3. Do the preceding problem on the assumption that the leather is so soft that every plane cross-section is a circle.

Ans. 536 cu. in.

4. A solid is generated by a variable hexagon which moves so that its plane is always perpendicular to a given diameter of a fixed circle, the centre of the hexagon lying in this diam-

eter, and its size varying so that two of its vertices always lie on the circle. Find the volume of the solid. *Ans.* $2\sqrt{3}a^3$.

5. A conoid is a wedge-shaped solid whose lateral surface is generated by a straight line which moves so as always to keep parallel to a fixed plane and to pass through a fixed circle and a fixed straight line; both the line and the plane of the circle being perpendicular to the fixed plane. Find the volume of the solid.

Ans. $\frac{1}{2}\pi a^2 h$.

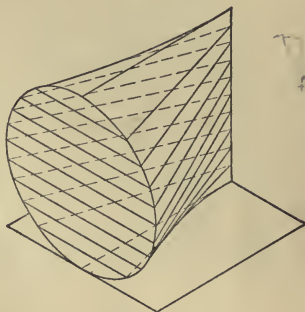

FIG. 50

6. Find the superficial area of two of the solids considered above.

7. Show that the volume of an ellipsoid whose semi-axes are of lengths a, b, c is $\frac{4}{3}\pi abc$.

5. Fluid Pressure. We will next consider the problem of finding the pressure of a liquid on a vertical wall. Let the surface be bounded as indicated in the figure and let it be divided into n strips by ordinates that are equally spaced. Denote the pressure on the k -th strip by ΔP_k . Then we can approximate to ΔP_k as follows. Consider the rectangle cut out of this strip by a parallel to the axis of x through the point (x_k, y_k) . The pressure on this rectangle is less than that on the given strip; but we do not yet know how great it is. Still, if we turn the rectangle through 90° about its upper side, the ordinate y_k , we shall obviously have decreased the pressure further. Now the pressure on the rectangle in this new posi-

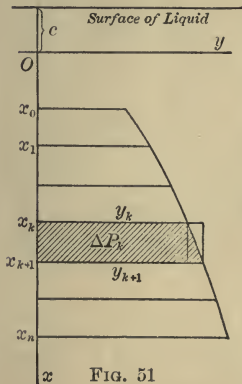

FIG. 51

tion is readily computed. It is precisely the weight of a column of the liquid standing on this rectangle as base. The volume of such a column is $(x_k + c)y_k \Delta x$, and if we denote by w the weight of a cubic unit of the liquid, then the weight of the column in question is

$$w(x_k + c)y_k \Delta x.$$

This is less than ΔP_k .

In like manner we can find a major approximation by considering the rectangle that circumscribes the given strip and whose altitude is y_{k+1} , and then turning it over on its lower base. The pressure on it in its new position is

$$w(x_{k+1} + c)y_{k+1} \Delta x,$$

and this is larger than ΔP_k . We thus obtain:

$$(9) \quad w(x_k + c)y_k \Delta x < \Delta P_k < w(x_{k+1} + c)y_{k+1} \Delta x.$$

If we write out the relations (9) for $k = 0, 1, \dots, n - 1$:

$$w(x_0 + c)y_0 \Delta x < \Delta P_0 < w(x_1 + c)y_1 \Delta x,$$

$$w(x_1 + c)y_1 \Delta x < \Delta P_1 < w(x_2 + c)y_2 \Delta x,$$

.

$$w(x_{n-1} + c)y_{n-1} \Delta x < \Delta P_{n-1} < w(x_n + c)y_n \Delta x,$$

and add them together, we see that the pressure P we seek to determine lies between

$$(10) \quad w(x_0 + c)y_0 \Delta x + w(x_1 + c)y_1 \Delta x + \dots + w(x_{n-1} + c)y_{n-1} \Delta x$$

and

$$(11) \quad w(x_1 + c)y_1 \Delta x + w(x_2 + c)y_2 \Delta x + \dots + w(x_n + c)y_n \Delta x.$$

Finally, allow n to become infinite. Each of the variables (10) and (11) approaches as its limit the definite integral

$$w \int_a^b (x + c)y dx.$$

But the pressure P always lies between these variables, and hence it must coincide with their common limit. Thus we see that

$$(12) \quad P = w \int_a^b (x + c)y \, dx.$$

We have deduced our result under the assumption that the ordinates of the bounding curve never decrease as x increases. The formula is true, however, even if this condition is not fulfilled, as we shall show in § 6.

Example 1. To find the pressure on the end of a tank that is full of water.

Here it is convenient to take the axis of y in the surface of the liquid, so that $c = 0$. The equation of the bounding curve is

$$y = k,$$

and thus

$$P = w \int_0^h xk \, dx = wk \left. \frac{x^2}{2} \right|_0^h = \frac{wh^2k}{2}.$$

Now the area of the rectangle is hk , so that, if we write the result in the form

$$P = w \cdot hk \cdot \frac{h}{2},$$

it appears that the total pressure is the same as what it would be if the rectangle were turned through 90° about a horizontal line through its centre of gravity and lying in its surface, and thus supported a column of the liquid of height $\frac{1}{2}h$.

Example 2. A water main 6 ft. in diameter is half full of water. Find the pressure on the gate that closes the main.

The pressure on half the gate is

$$w \int_0^3 x \sqrt{9 - x^2} \, dx,$$

where w , the weight of a cubic foot of water, is $62\frac{1}{2}$ lbs. Turning to Peirce's *Tables*, Formula 135, we find*

* The integral may be evaluated directly by introducing as a new variable of integration, $y = 9 - x^2$.

$$\int x\sqrt{9-x^2} dx = -\frac{1}{3}(9-x^2)^{\frac{3}{2}}.$$

Hence

$$\int_0^3 x\sqrt{9-x^2} dx = -\frac{1}{3}(9-x^2)^{\frac{3}{2}} \Big|_0^3 = 9,$$

and the total pressure is $2 \times 62\frac{1}{4} \times 9 = 1120$ lbs.

EXERCISES

1. A vertical masonry dam in the form of a trapezoid is 200 ft. long at the surface of the water, 150 ft. long at the bottom, and is 60 ft. high. What pressure must it withstand?

Ans. 9300 tons.

2. A cross-section of a trough is a parabola with vertex downward, the latus rectum lying in the surface and being 4 ft. long. Find the pressure on the end of the trough when it is full of water.

Ans. 66 lbs.

3. One end of an unfinished watermain 4 ft. in diameter is closed by a temporary bulkhead and the water is let in from the reservoir. Find the pressure on the bulkhead if its centre is 40 ft. below the surface of the water in the reservoir.

Ans. Nearly 16 tons.

6. Duhamel's Theorem. *Let*

$$\alpha_1 + \alpha_2 + \dots + \alpha_n$$

be a sum of positive infinitesimals which approaches a limit when n becomes infinite; and let

$$\beta_1 + \beta_2 + \dots + \beta_n$$

be a second sum such that β_k differs from α_k by an infinitesimal of higher order:

$$\lim_{n \rightarrow \infty} \frac{\beta_k}{\alpha_k} = 1, \quad \frac{\beta_k}{\alpha_k} = 1 + \epsilon_k, \quad \beta_k = \alpha_k + \epsilon_k \alpha_k,$$

where ϵ_k is infinitesimal. Then

$$\lim_{n \rightarrow \infty} [\beta_1 + \beta_2 + \dots + \beta_n] = \lim_{n \rightarrow \infty} [\alpha_1 + \alpha_2 + \dots + \alpha_n].$$

In accordance with the hypothesis of the theorem we have

$$\beta_1 + \beta_2 + \dots + \beta_n = \alpha_1 + \alpha_2 + \dots + \alpha_n$$

$$+ \epsilon_1 \alpha_1 + \epsilon_2 \alpha_2 + \dots + \epsilon_n \alpha_n,$$

and we wish to show that the last line of this equation approaches 0 when $n = \infty$. Let η be numerically the largest of the ϵ_k 's. Then

$$\left. \begin{array}{l} -\eta \leq \epsilon_1 \leq \eta, \\ -\eta \leq \epsilon_2 \leq \eta, \\ \dots \\ -\eta \leq \epsilon_n \leq \eta, \end{array} \right\} \quad \therefore \quad \left. \begin{array}{l} -\eta \alpha_1 \leq \epsilon_1 \alpha_1 \leq \eta \alpha_1, \\ -\eta \alpha_2 \leq \epsilon_2 \alpha_2 \leq \eta \alpha_2, \\ \dots \\ -\eta \alpha_n \leq \epsilon_n \alpha_n \leq \eta \alpha_n. \end{array} \right\}$$

Hence

$$-(\alpha_1 + \alpha_2 + \dots + \alpha_n) \eta \leq \epsilon_1 \alpha_1 + \dots + \epsilon_n \alpha_n \leq (\alpha_1 + \alpha_2 + \dots + \alpha_n) \eta.$$

But η approaches 0 and $\alpha_1 + \alpha_2 + \dots + \alpha_n$ remains finite. This completes the proof.

Application. As a typical application of Duhamel's Theorem we will give the completion of the proof of formula (12). Let y'_k be the minimum ordinate in the k -th strip, and let y''_k be the maximum ordinate. Then we have by like reasoning to that of § 5 :

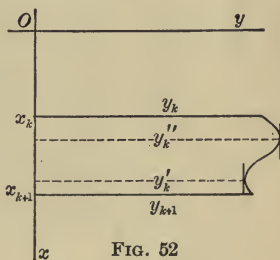

$$w(x_k + c)y'_k \Delta x < \Delta P_k < w(x_{k+1} + c)y''_k \Delta x,$$

and hence P lies between the two variables

$$(13) \quad w(x_0 + c)y'_0 \Delta x + w(x_1 + c)y'_1 \Delta x + \dots + w(x_{n-1} + c)y'_{n-1} \Delta x$$

and

$$(14) \quad w(x_1 + c)y''_0 \Delta x + w(x_2 + c)y''_1 \Delta x + \dots + w(x_n + c)y''_{n-1} \Delta x.$$

Neither of these variables is of the type to which the Fundamental Theorem of § 2 applies ; but each suggests the variable

$$(15) \quad w(x_0 + c)y_0 \Delta x + w(x_1 + c)y_1 \Delta x + \dots + w(x_{n-1} + c)y_{n-1} \Delta x,$$

whose limit is the definite integral (12), and each approaches the value of this integral as its limit, as we will now show.

$$\text{Let } \alpha_k = w(x_k + c) y_k \Delta x, \quad \beta_k = w(x_k + c) y'_k \Delta x.$$

$$\text{Then } \lim_{n \rightarrow \infty} (\alpha_1 + \alpha_2 + \cdots + \alpha_n) = \int_a^b w(x+c) y dx.$$

$$\text{Furthermore, } \frac{\beta_k}{\alpha_k} = \frac{w(x_k + c) y'_k \Delta x}{w(x_k + c) y_k \Delta x} = \frac{y'_k}{y_k}, \quad \lim_{n \rightarrow \infty} \frac{y'_k}{y_k} = 1.$$

Hence $\beta_1 + \beta_2 + \cdots + \beta_n$, *i.e.* the variable (13), approaches the value of the above integral as its limit.

In like manner it is shown that (14) approaches this same limit. Hence P is equal to this limit and (12) holds in all cases.

7. Length of a Curve. In Chap. VI § 8 we found the length of a curve by means of the indefinite integral,

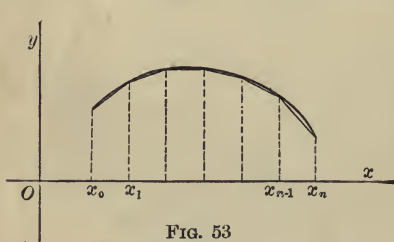

FIG. 53

$$s = \int \sqrt{1 + \left(\frac{dy}{dx}\right)^2} dx.$$

We can also evaluate the required length by considering it as the limit of a sum. Divide the interval from $x=a$ to $x=b$ into n equal parts, erect ordinates at the points of division, and inscribe a broken line in the arc to be measured. The length of this line is

$$\begin{aligned} & \sum_{k=0}^{n-1} \sqrt{\Delta x^2 + \Delta y_k^2} \\ &= \sqrt{\Delta x^2 + \Delta y_0^2} + \sqrt{\Delta x^2 + \Delta y_1^2} + \cdots + \sqrt{\Delta x^2 + \Delta y_{n-1}^2} \\ &= \sqrt{1 + \left(\frac{\Delta y_0}{\Delta x}\right)^2} \Delta x + \sqrt{1 + \left(\frac{\Delta y_1}{\Delta x}\right)^2} \Delta x + \cdots + \sqrt{1 + \left(\frac{\Delta y_{n-1}}{\Delta x}\right)^2} \Delta x, \end{aligned}$$

and the limit of its length is the length s to be determined. Now this latter variable is not of a type whose limit is a definite integral, but it suggests a new sum which is and

whose limit, moreover, can be identified with the above limit by Duhamel's Theorem; namely, since $\lim \Delta y_k / \Delta x = f'(x_k)$:

$$\sqrt{1 + f'(x_0)^2} \Delta x + \sqrt{1 + f'(x_1)^2} \Delta x + \cdots + \sqrt{1 + f'(x_{n-1})^2} \Delta x.$$

For, letting

$$\alpha_k = \sqrt{1 + f'(x_k)^2} \Delta x, \quad \beta_k = \sqrt{1 + \frac{\Delta y_k^2}{\Delta x^2}} \Delta x,$$

we see that

$$\lim_{n \rightarrow \infty} \frac{\beta_k}{\alpha_k} = 1.$$

Hence

$$(16) \quad s = \int_a^b \sqrt{1 + f'(x)^2} dx,$$

and this agrees with the earlier result above referred to.

8. Area of a Surface of Revolution. To find the lateral area of a surface of revolution we proceed in a manner similar to that employed in finding the volume, § 3. Divide the interval from $x = a$ to $x = b$ into n equal parts, erect ordinates, and inscribe a broken line in the arc of the generating curve, as in the preceding paragraph. This broken line, when it rotates about the axis of revolution, generates the lateral surfaces of a series of frusta of cones. Let us compute the lateral area of the k -th frustum. The lateral area of a cone is half the product of its slant height by the perimeter of its base, $\pi r l$. The corresponding formula for the frustum is the product of the slant height by the circumference of the circular cross-section made by a plane passed midway between the bases,

$$\pi(r + R)l.$$

Hence the lateral area in question is

$$(17) \quad \pi(y_k + y_{k+1}) \sqrt{\Delta x^2 + \Delta y_k^2},$$

and the area of the surface S that we wish to compute is thus seen to be:

$$(18) \quad S = \lim_{n \rightarrow \infty} \sum_{k=0}^{n-1} \pi(y_k + y_{k+1}) \sqrt{\Delta x^2 + \Delta y_k^2}.$$

Now the general summand (17) :

$$\beta_k = \pi(y_{k+1} + y_k) \sqrt{1 + \frac{\Delta y_k^2}{\Delta x^2}} \Delta x,$$

suggests the simpler expression :

$$\alpha_k = 2\pi y_k \sqrt{1 + f'(x_k)^2} \Delta x.$$

The sum $\alpha_1 + \alpha_2 + \dots + \alpha_n$ has for its limit $\int_a^b 2\pi y \sqrt{1 + f'(x)^2} dx$.

And since

$$\lim_{n \rightarrow \infty} \frac{\beta_k}{\alpha_k} = 1,$$

it follows from Duhamel's Theorem that the sum $\beta_1 + \beta_2 + \dots + \beta_n$, has the same limit. But the limit of this latter sum is, by (18), S . Hence we obtain the result:

$$(19) \quad S = 2\pi \int_a^b y \sqrt{1 + \frac{dy^2}{dx^2}} dx.$$

For example, we can now obtain with ease the theorem of solid geometry that the area of a zone of a sphere is the product of its altitude by the circumference of a great circle, regardless of where the zone is situated. We have

$$\begin{aligned} x^2 + y^2 &= r^2, \\ 1 + \frac{dy^2}{dx^2} &= 1 + \frac{x^2}{y^2} = \frac{r^2}{y^2}, \\ S &= 2\pi \int_a^{a+h} y \frac{r}{y} dx = 2\pi r x \Big|_a^{a+h} = 2\pi r h, \end{aligned} \quad \text{q. e. d.}$$

The area of the complete sphere is $4\pi r^2$.

EXERCISES

1. Find the area of a segment of a paraboloid of revolution, extending from the vertex. *Ans.* $\frac{2}{3}\pi(\sqrt{m(m+2x)^3} - m^2)$.

2. Find the area of an ellipsoid of revolution.

$$\text{Ans. } 2\pi \left(b^2 + \frac{ab}{e} \sin^{-1} e \right).$$

$$e = \frac{\sqrt{a^2 - b^2}}{a}$$

3. The curve

$$x^{\frac{2}{3}} + y^{\frac{2}{3}} = a^{\frac{2}{3}}$$

rotates about the axis of x . Find the total superficial area of the surface generated.

$$\text{Ans. } \frac{12\pi a^2}{5}.$$

4. An arch of a cycloid rotates about its base. Determine the superficial area of the surface generated.

$$\text{Ans. } \frac{64\pi a^2}{3}.$$

5. Show that in polar coordinates

$$(20) \quad S = 2\pi \int_{\alpha}^{\beta} r \sin \theta \sqrt{r^2 + \frac{dr^2}{d\theta^2}} d\theta.$$

6. Find the area of the surface generated by the rotation of the cardioid

$$r = 2a(1 - \cos \theta)$$

about its axis.

$$\text{Ans. } \frac{128\pi a^2}{5}.$$

7. Show that the area of a surface of revolution is given by the formula

$$(21) \quad S = 2\pi \int_{s_0}^{s_1} y ds,$$

where the coordinates x, y of a point of the generating curve are expressed as functions of the length of the arc, s .

9. Centre of Gravity. *A Law of Statics.* Let n particles, of masses m_1, m_2, \dots, m_n , be situated on a straight line, which we will take as the axis of x , and let their coordinates be x_1, x_2, \dots, x_n . Then the coordinate \bar{x} of their centre of gravity is given by the formula: *

$$(22) \quad \bar{x} = \frac{m_1 x_1 + m_2 x_2 + \dots + m_n x_n}{m_1 + m_2 + \dots + m_n}.$$

* A proof of this formula may be found in any work on Mechanics, for example, Jeans, *Theoretical Mechanics*, Chap. VI.

If the particles are situated in a plane at the points $(x_1, y_1), \dots, (x_n, y_n)$ or in space at the points $(x_1, y_1, z_1), \dots, (x_n, y_n, z_n)$, and if (\bar{x}, \bar{y}) or $(\bar{x}, \bar{y}, \bar{z})$ is their centre of gravity, then \bar{x} is given by the same formula (22), and \bar{y} and \bar{z} are given by similar formulas, in which the x 's are all replaced by y 's or z 's.

Example. A granite column 6 ft. high and $1\frac{1}{2}$ ft. in diameter is capped by a ball of the same substance 2 ft. in diameter and stands on a cylindrical granite pedestal 9 in. high and 2 ft. in diameter. How high above the ground is the centre of gravity of the whole post? *Ans.* 4.26 ft.

10. Centre of Gravity of Solids and Surfaces of Revolution.

By the aid of the Calculus we can compute the centre of gravity of bodies not made up of a finite number of particles or of bodies whose centres of gravity are known. We will begin with homogeneous solids of revolution. Their centre of gravity always lies somewhere in the axis of symmetry. Divide the body into slabs as in § 3, Fig. 48, and denote the abscissa of the centre of gravity of the k -th slab by x'_k . Then, if ρ denote the density of the substance, the mass of the k -th slab is $\rho \Delta V_k$, and

$$\begin{aligned}\bar{x} &= \frac{\rho \Delta V_0 \cdot x'_0 + \rho \Delta V_1 \cdot x'_1 + \dots + \rho \Delta V_{n-1} \cdot x'_{n-1}}{\rho \Delta V_0 + \rho \Delta V_1 + \dots + \rho \Delta V_{n-1}} \\ &= \frac{x'_0 \Delta V_0 + x'_1 \Delta V_1 + \dots + x'_{n-1} \Delta V_{n-1}}{V}.\end{aligned}$$

Here

$$V = \pi \int_a^b y^2 dx,$$

and it remains to compute the value of the numerator. Since this sum has the same value for all values of n , namely $\bar{x}V$, we may allow n to increase without limit, and we shall have

$$(23) \quad \lim_{n \rightarrow \infty} [x'_0 \Delta V_0 + x'_1 \Delta V_1 + \dots + x'_{n-1} \Delta V_{n-1}] = \bar{x}V.$$

Now this bracket readily suggests a sum whose limit can be computed by integration. Since

$$x_k < x'_k < x_{k+1}$$

and

$$\pi y'_k{}^2 \Delta x \leq \Delta V_k \leq \pi y''_k{}^2 \Delta x,$$

where y'_k and y''_k are respectively the smallest and the largest radii of any cross-section of the k -th slab, we see that

$$\pi x_k y'_k{}^2 \Delta x < x'_k \Delta V_k < \pi x_{k+1} y''_k{}^2 \Delta x.$$

Hence if we put

$$\alpha_k = \pi x_k y_k{}^2 \Delta x, \quad \beta_k = x'_k \Delta V_k,$$

we shall have

$$\frac{\beta_k}{\alpha_k} = \frac{x'_k}{x_k} \cdot \frac{\Delta V_k}{\pi y_k{}^2 \Delta x}, \quad \lim_{n \rightarrow \infty} \frac{\beta_k}{\alpha_k} = 1.$$

It follows, then, from Duhamel's Theorem that we can replace the individual terms of the sum in (23), namely $\beta_k = x'_k \Delta V_k$, by $\alpha_k = \pi x_k y_k{}^2 \Delta x$. We thus obtain:

$$\lim_{n \rightarrow \infty} [\pi x_0 y_0{}^2 \Delta x + \pi x_1 y_1{}^2 \Delta x + \dots + \pi x_{n-1} y_{n-1}{}^2 \Delta x] = \bar{x} V.$$

The left-hand side of this equation is a definite integral, and so we are led to the result:

$$(24) \quad \bar{x} = \frac{\pi \int_a^b xy^2 dx}{V}.$$

For example, let us find the centre of gravity of a cone of revolution. Here

$$V = \frac{1}{3} \pi r^2 h, \quad y = \frac{r}{h} x,$$

$$\int_a^b xy^2 dx = \frac{r^2}{h^2} \int_a^b x^3 dx = \frac{r^2}{h^2} \cdot \frac{x^4}{4} \Big|_0^h = \frac{r^2 h^2}{4}$$

and

$$\bar{x} = \frac{\frac{1}{4} \pi r^2 h^2}{\frac{1}{3} \pi r^2 h} = \frac{3}{4} h,$$

i.e. the centre of gravity is three-fourths of the distance from the vertex to the base.

EXERCISES

✓ 1. How far is the centre of gravity of a hemisphere from the centre of the sphere? *Ans.* $\frac{3}{8}r$.

✓ 2. Find the centre of gravity of a segment of a paraboloid of revolution.

3. Find the centre of gravity of a segment of a sphere.

✓ 4. Find the centre of gravity of a frustum of a cone.

Ans. Distance from smaller base, $\frac{h}{4} \cdot \frac{3R^2 + 2Rr + r^2}{R^2 + Rr + r^2}$.

✓ 5. The curve

$$y = \sin x, \quad 0 \leq x \leq \frac{\pi}{2},$$

rotates about the axis of x . Find the centre of gravity of the solid generated.

$$\text{Ans. } \bar{x} = \frac{\pi}{4} + \frac{1}{\pi} = 1.10.$$

✓ 6. Show that the centre of gravity of a surface of revolution bounded by two planes perpendicular to the axis is given by the formula

$$\bar{x} = \frac{2\pi \int_{s_0}^{s_1} xy \, ds}{S} = \frac{2\pi \int_a^b xy \sqrt{1 + \frac{dy^2}{dx^2}} \, dx}{S}.$$

7. Prove that the centre of gravity of any zone of a sphere lies midway between the bases of the zone.

✓ 8. Find the centre of gravity of the lateral surface of a cone of revolution. *Ans.* $\frac{2}{3}h$.

✓ 9. Find the centre of gravity of the lateral surface of a segment of a paraboloid.

11. Centre of Gravity of Plane Areas. To find the abscissa of the centre of gravity of the area under a curve, $y = f(x)$, § 1, Fig. 47, divide the area into n strips of equal breadth as there described, and consider the centre of gravity of these strips. If the area of the k -th strip be denoted by Δ_k , and the super-

ficial density, supposed constant (*i.e.* the mass of one square unit of the slab), by ρ , then the mass of the k -th strip will be $\rho \Delta A_k$. Let the abscissa of its centre of gravity be x'_k . Then we shall have

$$\begin{aligned}\bar{x} &= \frac{\rho \Delta A_0 \cdot x'_0 + \rho \Delta A_1 \cdot x'_1 + \cdots + \rho \Delta A_{n-1} \cdot x'_{n-1}}{\rho \Delta A_0 + \rho \Delta A_1 + \cdots + \rho \Delta A_{n-1}} \\ &= \frac{x'_0 \Delta A_0 + x'_1 \Delta A_1 + \cdots + x'_{n-1} \Delta A_{n-1}}{A}.\end{aligned}$$

Here

$$A = \int_a^b y dx,$$

and it remains to compute the value of the numerator. The reasoning is precisely similar to that of the preceding paragraph. We allow n to become infinite and thus obtain

$$\lim_{n=\infty} [x'_0 \Delta A_0 + x'_1 \Delta A_1 + \cdots + x'_{n-1} \Delta A_{n-1}] = \bar{x}A.$$

Now

$$x_k < x'_k < x_{k+1},$$

$$y'_k \Delta x \leq \Delta A_k \leq y''_k \Delta x,$$

and hence, if $\alpha_k = x_k y_k \Delta x$, $\beta_k = x'_k \Delta A_k$,

$$\lim_{n=\infty} \frac{\beta_k}{\alpha_k} = 1.$$

It follows, then, from Duhamel's Theorem that

$$\lim_{n=\infty} [x_0 y_0 \Delta x + x_1 y_1 \Delta x + \cdots + x_{n-1} y_{n-1} \Delta x] = \bar{x}A,$$

$$(25) \quad \bar{x} = \frac{\int_a^b xy dx}{A}.$$

EXERCISES

1. Find the centre of gravity of a semicircle.

$$Ans. \quad \bar{x} = \frac{4r}{3\pi} = .425r.$$

2. Find the centre of gravity of a parabolic segment.

$$\text{Ans. } \bar{x} = \frac{3}{5} h.$$

3. Find the centre of gravity of half an ellipse, bounded by an axis.

$$\text{Ans. } \bar{x} = \frac{4a}{3\pi} = .425a.$$

4. Show that the abscissa of the centre of gravity of an arbitrary plane area whose boundary is cut by a parallel to the axis of ordinates at most in two points is given by the formula :

$$\bar{x} = \frac{\int_a^b x(y'' - y') dx}{A},$$

where $y' = \phi(x)$ is the equation of the lower boundary, and $y'' = f(x)$ that of the upper one.

5. Show that the centre of gravity of a triangle lies at the intersection of the medians.

6. Show that the centre of gravity of a uniform wire of length l is given by the formula:

$$\bar{x} = \frac{\int_0^l x ds}{l} = \frac{\int_a^b x \sqrt{1 + \frac{dy^2}{dx^2}} dx}{l}.$$

7. Find the centre of gravity of a uniform semi-circular wire.

$$\text{Ans. } \bar{x} = \frac{2r}{\pi} = .637 r.$$

12. General Formulation. The foregoing examples may all be brought under one general formulation, which applies furthermore to bodies of variable density and wholly arbitrary shape. Let the body be divided into small pieces, and denote the mass of any piece by ΔM_k , the abscissa of its centre of gravity by x'_k . Then

$$\bar{x} = \frac{\sum_{k=0}^{n-1} x'_k \Delta M_k}{M},$$

and hence

$$(26) \quad \bar{x} = \frac{\lim_{n \rightarrow \infty} \sum_{k=0}^{n-1} x'_k \Delta M_k}{M}.$$

The latter limit can always be computed by means of integrals, but it may be necessary to employ double or triple integrals, cf. the later chapters. Formula (26) is sometimes written in the form :

$$(27) \quad \bar{x} = \frac{\int x dM}{M}.$$

13. Centre of Fluid Pressure. Let us determine at what height a horizontal brace should be applied to hold the pressure of the liquid computed in § 5, without there being any tendency of the surface to rotate about the brace. Divide the surface into strips, as in § 5, Fig. 51, and consider the pressures on the successive strips. As in the problem of the centre of gravity of n particles, we have here again to do with the abscissa of the resultant of a system of parallel forces. Let the abscissa of the point at which the pressure ΔP_k on the k -th strip acts be denoted by x'_k , the abscissa of the brace by \bar{x} . Then

$$\bar{x} = \frac{x'_0 \Delta P_0 + x'_1 \Delta P_1 + \cdots + x'_{n-1} \Delta P_{n-1}}{\Delta P_0 + \Delta P_1 + \cdots + \Delta P_{n-1}}.$$

The value of the denominator is

$$P = w \int_a^b (x + c) y dx.$$

Allowing n in the numerator to increase without limit, we obtain by reasoning now familiar to us the result :

$$\bar{x} = \frac{w \int_a^b (x + c) xy dx}{P}.$$

For example, to find the centre of pressure for the rectangle considered in § 5. Here

$$P = \frac{1}{2}wh^2k,$$

$$\int_a^b (x+c)xy \, dx = k \int_0^h x^2 \, dx = \frac{h^3k}{3},$$

$$\therefore \bar{x} = \frac{2}{3}h,$$

and the brace should be applied to the end of the tank two-thirds of the way down.

EXERCISE

Find the depth of the centre of pressure in the case of the dam described in § 5, Ex. 1.

14. Moment of Inertia. By the *moment of inertia* of a system of particles about a straight line in space, called the *axis*, is meant the quantity

$$(28) \quad \sum_{k=1}^n m_k r_k^2 = m_1 r_1^2 + m_2 r_2^2 + \cdots + m_n r_n^2,$$

where r_k denotes the perpendicular distance of the k -th particle, whose mass is m_k , from the axis.

If a body consists of a continuous distribution of matter, like a wire or a plate or a solid body, its moment of inertia is defined as follows. Let the body be divided up into small pieces, of mass m_k , and let the mass of each piece be concentrated at one of its points, whose distance from the axis shall be denoted by r_k . Form the sum (28) for all the pieces. Then the limit of this sum as the pieces grow smaller and smaller is the moment of inertia of the body :

$$(29) \quad I = \lim_{n \rightarrow \infty} \sum_{k=1}^n m_k r_k^2.$$

The physical meaning of the moment of inertia is the measure of the resistance which the body opposes, through

its inertia, to being rotated about the axis. The moment of inertia also has an important application in the theory of the strength of materials.

By means of the Calculus we can compute the moment of inertia of any body.

Let us begin with a circular wire, of radius r and mass m , the axis being perpendicular to the plane of the circle and passing through its centre. Here every point in the matter in question is at the same distance r from the axis, and so the moment of inertia is

$$I = mr^2.$$

Next, consider a uniform circular disc. Divide its radius into n equal parts: $r_0 = 0, r_1, r_2, \dots, r_n = a$, and cut the disc up into rings by concentric circles of radii r_1, \dots, r_{n-1} . The moment of inertia of the whole disc is equal to the sum of the moments of inertia of these rings. Now the moment of inertia of the k -th ring, ΔI_k , evidently is greater than what it would be if its mass were concentrated along its inner boundary, but less than if its mass were concentrated along its outer boundary. Hence

$$(30) \quad r_k^2 \Delta M_k < \Delta I_k < r_{k+1}^2 \Delta M_k.$$

Furthermore, $\Delta M_k = \rho \Delta A_k$, where ρ denotes the density and ΔA_k the area:

$$(31) \quad \begin{aligned} \Delta A_k &= \pi r_{k+1}^2 - \pi r_k^2 = \pi (r_k + \Delta r)^2 - \pi r_k^2 = 2\pi r_k \Delta r + \pi \Delta r^2, \\ \Delta M_k &= 2\pi \rho r_k \Delta r + \pi \rho \Delta r^2. \end{aligned}$$

We are now in a position to apply Duhamel's Theorem. We have

$$\begin{aligned} I &= \Delta I_0 + \Delta I_1 + \dots + \Delta I_{n-1} \\ &= \lim_{n \rightarrow \infty} [\Delta I_0 + \Delta I_1 + \dots + \Delta I_{n-1}]. \end{aligned}$$

On the other hand, formulas (30) and (31) suggest a simpler infinitesimal by which to replace ΔI_k , namely

$$a_k = 2\pi \rho r_k^3 \Delta r.$$

In fact, if we divide (30) through by α_k :

$$\frac{r_k^2 \Delta M_k}{2\pi\rho r_k^3 \Delta r} < \frac{\Delta I_k}{2\pi\rho r_k^3 \Delta r} < \frac{r_{k+1}^2 \Delta M_k}{2\pi\rho r_k^3 \Delta r},$$

we see that the limit of either extreme is 1, and so the limit of the middle expression must also be 1. Putting, then, $\beta_k = \Delta I_k$, we get :

$$\lim_{n \rightarrow \infty} \frac{\beta_k}{\alpha_k} = 1.$$

Hence

$$I = \lim_{n \rightarrow \infty} \sum_{k=0}^{n-1} 2\pi\rho r_k^3 \Delta r = 2\pi\rho \int_0^a r^3 dr = \frac{\pi\rho a^4}{2}.$$

The mass of the disc is $M = \pi\rho a^2$, and consequently I may be written in the form :

$$(32) \quad I = \frac{Ma^2}{2}.$$

Definition. If the moment of inertia of a body be written in the form :

$$I = Mk^2,$$

k is called the *radius of gyration*. The radius of gyration is defined, then, as $\sqrt{I/M}$. It may be interpreted as follows: if all the mass were spread out uniformly along a circular wire of radius k , the axis passing through the centre of the ring at right angles to its plane, the moment of inertia would still be the same: $I = Mk^2$. The radius of gyration of the above circular plate is $a/\sqrt{2}$.

EXERCISES

Determine the following moments of inertia.

1. A uniform rod, of length $2a$, about a perpendicular bisector.

$$\text{Ans. } \frac{Ma^2}{3}.$$

2. A square whose sides are of length $2a$, about a parallel to a side through the centre.

$$\text{Ans. } \frac{Ma^2}{3}.$$

3. A uniform rod of length l about a perpendicular through one end.

$$\text{Ans. } \frac{Ml^2}{3}.$$

✓ 4. A circular disc about a diameter.

$$\text{Ans. } \frac{Ma^2}{4}.$$

✓ 5. An isosceles triangle about the median through the vertex.

$$\text{Ans. } \frac{Ma^2}{6}, \text{ where } a \text{ is half the length of the base.}$$

6. A scalene triangle about a median.

$\text{Ans. } \frac{Mh^2}{6}$, where h is the distance of either vertex from the median.

✓ 7. A circular wire about a diameter.

$$\text{Ans. } \frac{Ma^2}{2}.$$

✓ 8. A cone of revolution about its axis.

$$\text{Ans. } \frac{3Mr^2}{10}.$$

9. A sphere about a diameter.

$$\text{Ans. } \frac{2Ma^2}{5}.$$

15. A General Theorem. When the moment of inertia of a body about an axis is once known, its moment of inertia about any parallel axis can be found without performing a new integration. The theorem is as follows.

THEOREM. *If the moment of inertia of a body about an arbitrary axis be denoted by I_0 , that about a parallel axis through the centre of gravity by I , then*

$$(33) \quad I_0 = I + Mh^2,$$

where h denotes the distance between the axes.

We will prove the theorem first for a system of particles. Assume a set of cartesian coordinates (x, y, z) , the axis of z being taken as the first axis of the theorem, and then take a second set of cartesian coordinates (x', y', z') parallel to the first, the origin being at the centre of gravity. Then we have:

$$I_0 = \sum m r^2 = \sum m (x^2 + y^2),$$

$$I = \sum m r'^2 = \sum m (x'^2 + y'^2).$$

Furthermore,

$$x = x' + \bar{x}, \quad y = y' + \bar{y}, \quad z = z' + \bar{z},$$

where $(\bar{x}, \bar{y}, \bar{z})$ is the centre of gravity referred to the (x, y, z) axes. Hence

$$\begin{aligned} \sum m (x^2 + y^2) &= \sum m (x'^2 + y'^2) + 2\bar{x} \sum m x' + 2\bar{y} \sum m y' \\ &\quad + M(\bar{x}^2 + \bar{y}^2). \end{aligned}$$

Now $\sum m x' = 0, \quad \sum m y' = 0.$

For, recall formula (22) in § 9. Applying that formula to the present system of particles, referred to the (x', y', z') -axes, we see that the abscissa of the centre of gravity, \bar{x}' , is:

$$\bar{x}' = \frac{\sum m x'}{M}.$$

But the centre of gravity is at the new origin of coordinates, and so $\bar{x}' = 0$, hence $\sum m x' = 0$. Similarly, $\sum m y' = 0$.

It remains only to interpret the terms that are left, and thus the theorem is proven for a system of particles.

If we have a body consisting of a continuous distribution of matter, we divide it up into small pieces, concentrate the mass of each piece at its centre of gravity, form the above sums, and take their limits. We shall have as before $\sum m x' = 0$, $\sum m y' = 0$, and hence

$$\sum m (x^2 + y^2) = \sum m (x'^2 + y'^2) + M h^2,$$

$$\lim \sum m (x^2 + y^2) = \lim \sum m (x'^2 + y'^2) + M h^2, \quad \text{q. e. d.}$$

EXERCISES

Determine the following moments of inertia.

1. A circular disc about a point in its circumference.*

$$\text{Ans. } \frac{3Ma^2}{2}.$$

2. A uniform rod, of length $2a$, about a point in its perpendicular bisector.

$$\text{Ans. } M\left(\frac{a^2}{3} + h^2\right).$$

3. A rectangle, of sides $2a$ and $2b$, about its centre of gravity.

$$\text{Ans. } \frac{M(a^2 + b^2)}{3}.$$

4. The following figures about the axis through the centre of gravity parallel to the lines of the page:

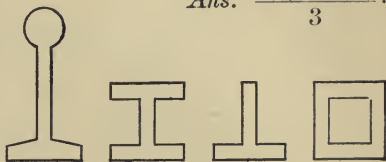

FIG. 54

16. The Attraction of Gravitation. Sir Isaac Newton discovered the law of universal gravitation. This law asserts that any two particles in the universe attract each other with a force proportional to their masses and inversely proportional to the square of the distance between them:

$$(34) \quad f \propto \frac{mm'}{r^2}, \quad f = K \frac{mm'}{r^2},$$

where K is a physical constant.†

By means of the Calculus we can compute the force with which bodies consisting of a continuous distribution of matter attract one another. Let us determine the force which a uniform rod of mass M exerts on a particle of mass m situated

* By the moment of inertia of any distribution of matter in a plane about a point in that plane is meant the moment of inertia about an axis through the point perpendicular to the plane.

† Called the *gravitational constant*. Its value is

$$6.5 \times 10^{-8} \text{ cm}^3 \text{ sec}^{-2} \text{ gr}^{-1}.$$

in its own line. Divide the rod up into n equal parts and denote the attraction of the k -th segment by ΔA_k . The mass

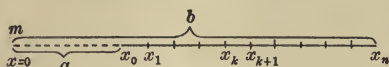

FIG. 55

of this segment is $\rho \Delta x$, where ρ denotes the density of the rod. Now if this whole mass $\rho \Delta x$ were concentrated at the nearer end, its attraction would be greater than ΔA_k ; and similarly, if it were concentrated at the further end, its attraction would be less. Hence

$$K \frac{m\rho \Delta x}{x_{k+1}^2} < \Delta A_k < K \frac{m\rho \Delta x}{x_k^2}.$$

It follows, then, from Duhamel's Theorem, if we set

$$\beta_k = \Delta A_k, \quad \alpha_k = K \frac{m\rho \Delta x}{x_k^2},$$

that

$$\begin{aligned} A &= \sum_{k=0}^{n-1} \Delta A_k = \lim_{n \rightarrow \infty} \sum_{k=0}^{n-1} \Delta A_k \\ &= \lim_{n \rightarrow \infty} \sum_{k=0}^{n-1} K \frac{m\rho \Delta x}{x_k^2} = Km\rho \int_a^b \frac{dx}{x^2} \\ &= Km\rho \left[\frac{1}{a} - \frac{1}{b} \right] = \frac{Km\rho(b-a)}{ab}. \end{aligned}$$

This result may be written in the form

$$A = K \frac{mM}{ab},$$

and thus it appears that the rod attracts with the same force as a particle of like mass situated at a distance from m equal to the geometric mean of the distances a and b of the ends of the rod.

Secondly, suppose the particle were situated in a perpendicular bisector of the rod. Divide the rod as before and consider the attraction of the k -th segment. We must now, however, resolve this force into two components, one perpendicular, the other parallel to the rod. The latter components

annul each other for reasons of symmetry, and it is only the sum of the former,

$$\sum \Delta F_k,$$

that we need consider further. We may confine ourselves, moreover, to half the rod and multiply the final result by 2. It is clear that*

$$K \frac{m\rho \Delta x}{r_{k+1}^2} \cos \phi_{k+1} < \Delta F_k < K \frac{m\rho \Delta x}{r_k^2} \cos \phi_k,$$

and hence we infer by the usual method of reasoning that

$$\frac{1}{2} F = Km\rho \int_0^a \frac{\cos \phi \, dx}{r^2}.$$

Here $r^2 = h^2 + x^2,$ $\cos \phi = \frac{h}{\sqrt{h^2 + x^2}},$

and so we have

$$F = 2 Km\rho h \int_0^a \frac{dx}{\sqrt{(h^2 + x^2)^3}}.$$

From Peirce's *Tables*, Formula 138,

$$\int \frac{dx}{\sqrt{(h^2 + x^2)^3}} = \frac{x}{h^2 \sqrt{h^2 + x^2}},$$

and consequently

$$F = \frac{2 Km\rho}{h} \cdot \frac{x}{\sqrt{h^2 + x^2}} \Big|_0^a = \frac{2 Km\rho a}{h \sqrt{h^2 + a^2}} = K \frac{mM}{h \sqrt{h^2 + a^2}}.$$

EXERCISES

Compute the following attractions.

1. A rod whose density varies as the distance from one of its ends, on a particle in its own line.

$$\text{Ans. } \frac{2 KmM}{l^2} \left[\log \frac{l+h}{h} + \frac{h}{l+h} - 1 \right].$$

* This relation holds for the part of the rod we are considering; namely, when $\phi_k > 0$. For the other half a modification is necessary.

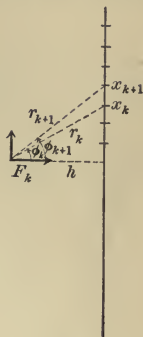

FIG. 56

- ✓ 2. A semicircular wire, on a particle at its centre. Ans. $\frac{2KmM}{\pi a^2}$.
- ✓ 3. The same wire, on a particle in the circumference situated symmetrically as regards the wire. Ans. $\frac{KmM}{\pi a^2} \log \tan \frac{3\pi}{8}$.
- ✓ 4. A rod AB , on a particle situated at O in a perpendicular OB at one end.
 Ans. A force of $\frac{2KmM}{hl} \sin \frac{1}{2}AOB$, making an angle of $\frac{1}{2}AOB$ with OB .
- ✓ 5. A circular disc, on a particle in the perpendicular to the disc at its centre. Ans. $\frac{2KmM}{a^2} \left[1 - \frac{h}{\sqrt{h^2 + a^2}} \right]$.

6. A rectangle, on a particle in a parallel to two of the sides through the centre.

For further simple problems in attraction cf. Peirce, *Newtonian Potential Function*.

17. Proof of Formula (3). We can give a proof of (3) as follows. Suppose that y increases with x , as in Fig. 57. Then the above rectangles are all inscribed in the curve and their sum is less than the area A :

$$(35) \quad f(x_0)\Delta x + f(x_1)\Delta x + \cdots + f(x_{n-1})\Delta x < A.$$

Consider now a second set of rectangles circumscribed about the strips into which we have divided A . Their sum is greater than A :

$$(36) \quad A < f(x_1)\Delta x + \cdots + f(x_{n-1})\Delta x + f(x_n)\Delta x.$$

Thus A lies between the two variable sums (35) and (36). These sums differ from each other only in the first term of (35), $f(a)\Delta x$, and the last term of (36), $f(b)\Delta x$, i.e. they differ by the quantity:

$$(37) \quad [f(b) - f(a)]\Delta x,$$

a quantity that approaches 0 as its limit when $n = \infty$. Hence each of the sums (35) and (36) approaches A , and we have :

$$(38) \quad \begin{aligned} A &= \lim_{n \rightarrow \infty} [f(x_0)\Delta x + f(x_1)\Delta x + \cdots + f(x_{n-1})\Delta x] \\ &= \lim_{n \rightarrow \infty} [f(x_1)\Delta x + f(x_2)\Delta x + \cdots + f(x_n)\Delta x]. \end{aligned}$$

Geometrically the difference between any inscribed rectangle and its corresponding circumscribed rectangle is the area of the little shaded rectangle. If we slide all these latter rectangles over into the last strip, they will form a rectangle whose base is Δx and whose altitude is $f(b) - f(a)$. Its area, then, is precisely the difference (37).

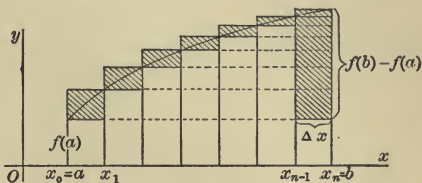

FIG. 57

It is not essential that the lengths of the intervals $x_1 - x_0 = \Delta x_0$, $x_2 - x_1 = \Delta x_1$, ... be equal. Let the greatest of these lengths be denoted by h . Then the difference between the sums

$$f(x_0)\Delta x_0 + f(x_1)\Delta x_1 + \cdots + f(x_{n-1})\Delta x_{n-1},$$

and
$$f(x_1)\Delta x_0 + f(x_2)\Delta x_1 + \cdots + f(x_n)\Delta x_{n-1},$$

as is seen from a figure similar to Fig. 57, will be less than

$$[f(b) - f(a)]h,$$

and so each sum approaches A as its limit.

If y decreases as x increases, the reasoning is similar, only the sum of the inscribed rectangles is now given by (36), that of the circumscribed rectangles by (35), and it remains to reverse the inequality signs in (35) and (36) and change the signs in (37).

Finally, if the curve has a finite number of maxima and minima, it may be divided into segments such that, in each of these, y steadily increases (or remains constant) or steadily

decreases (or remains constant). That part of the total sum which corresponds to strips lying wholly under any one of these segments is shown as in the preceding discussion to approach the area under that segment as its limit; and the sum of the finite number of terms in (35) left over approaches 0. Hence (3), and likewise (5), is true, even when the curve has a finite number of maxima and minima in the interval (a, b) .

Variable Limits of Integration. Let $f(x)$ be continuous in the interval $a \leq x \leq b$, and let x' be chosen arbitrarily in this interval. Then the definite integral

$$\int_a^{x'} f(x) dx$$

is a function of x' , $\phi(x')$. We may denote the variable of integration, x , by t , and at the same time change x' to x . Thus we have:

$$(39) \quad \phi(x) = \int_a^x f(t) dt.$$

The integral on the right-hand side represents the area under the curve, bounded by a variable ordinate whose abscissa is x . Hence its derivative has the value (Chap. VI, § 1) $f(x)$, and thus we see that

$$(40) \quad \phi'(x) = f(x) \quad \text{or} \quad \frac{d}{dx} \int_a^x f(t) dt = f(x).$$

Finally, the variable of integration, t , is often denoted by the same letter as the variable upper limit, (40) thus being written:

$$(41) \quad \phi(x) = \int_a^x f(x) dx.$$

EXERCISES

1. A cycloid revolves about the tangent at its vertex. Show that the volume of the solid generated is $\pi^2 a^3$.

2. Show that the volume of the solid generated by a curve that revolves about the axis of y is given by the formula:

$$V = \pi \int_{y_0}^{y_1} x^2 dy.$$

3. A cycloid revolves about its axis, *i.e.* the line through the vertex perpendicular to the base. Show that the volume of the solid generated is $\pi a^3 \left(\frac{3\pi^2}{2} - \frac{8}{3} \right)$.

4. If the curve

$$y^2(x - 4a) = ax(x - 3a)$$

revolve about the axis of x , show that the volume of the solid generated by the loop is $\pi a^3 (7\frac{1}{2} - 8 \log 2)$. Compute this volume correct to three significant figures when $a = 1$.

Ans. 6.12.

5. The curve $y^2 = x(x - 1)(x - 2)$ revolves about the axis of x . Show that the volume of the solid generated by the oval is $\frac{1}{4}\pi$.

6. Find the volume of the solid generated by the catenary

$$y = \frac{1}{2}(e^x + e^{-x})$$

when it rotates about the axis of y .

Ans. $\frac{\pi}{2} [(r^2 - 2r + 2)e^r + (r^2 + 2r + 2)e^{-r} - 4]$, where r denotes the radius of the base.

7. Find the volume of a torus (anchor ring). *Ans.* $2\pi^2 a^2 b$.

8. Find the area of the surface of a torus.

9. Find the area of the loop of the curve

$$x^3 - 3axy + y^3 = 0. \quad \text{Ans. } \frac{3}{2}a^2.$$

10. Find the area of the loop of the curve

$$r \cos \theta = a \cos 2\theta. \quad \text{Ans. } \left(2 - \frac{\pi}{2}\right)a^2.$$

11. Obtain the area of the surface of a segment of the solid generated by the rotation of a catenary

$$y = \frac{a}{2}(e^{\frac{x}{a}} + e^{-\frac{x}{a}})$$

(a) about the axis of x ; (b) about the axis of y .

Ans. (a) $\pi(ys + ax)$; (b) $2\pi(a^2 + xs - ay)$, where s denotes the length of the arc measured from the origin.

12. The kinetic energy of a system of particles, moving in any manner, is the sum of the kinetic energies of the individual particles, $\sum_{k=1}^n \frac{1}{2} m_k v_k^2$.

Show that the kinetic energy of a uniform rod of length $2a$, which is rotating about its perpendicular bisector with angular velocity ω , is $\frac{1}{6}Ma^2\omega^2$.

13. A pendulum consisting of a rectangular lamina oscillates about an axis perpendicular to its plane and passing through the middle point of one of its sides. Compute its kinetic energy.

$$\text{Ans. } M\left(\frac{4}{3}a^2 + \frac{1}{3}b^2\right)\omega^2.$$

14. A homogeneous cylinder rotates about its axis. Find its kinetic energy.

$$\text{Ans. } \frac{1}{4}Ma^2\omega^2.$$

15. Show that the kinetic energy of a rigid body, rotating with angular velocity ω about any axis, is $\frac{1}{2}I\omega^2$, where I denotes the moment of inertia about the axis.

16. The density of water under a pressure of p atmospheres is given by the formula:

$$\rho = \rho_0 (1 + .00004 p),$$

where p denotes the pressure measured in atmospheres. Show that the surface of an ocean six miles deep lies a little over 600 ft. deeper than it would if water were incompressible.

17. The perimeter of an ellipse whose major axis $2a$ is twice as long as the minor axis can be shown to be $4.84a$. (*Infinite Series*, p. 30.) Find the centre of gravity of a uniform wire in the form of half such an ellipse, the ends being at the extremities of the minor axis.

CHAPTER X

MECHANICS

1. The Laws of Motion. Sir Isaac Newton discovered the laws on which the science of Mechanics rests. They are as follows :

FIRST LAW. *A body at rest remains at rest and a body in motion moves in a straight line with unchanging velocity, unless some external force acts on it.*

SECOND LAW. *The rate of change of the momentum of a body is proportional to the resultant external force that acts on the body.*

THIRD LAW. *Action and reaction are equal and opposite.*

The meaning of the First and Third Laws is obvious. In the Second Law the *momentum* of the body is to be understood as the product of its mass by its velocity, mv . And since, in the vast majority of cases which we meet in practice, the mass is constant, we have

$$\frac{d(mv)}{dt} = m \frac{dv}{dt}.$$

Now the rate at which the velocity changes, dv/dt , is what we commonly call *acceleration*, — we will denote it by α ; — and hence the Second Law may be expressed as follows :

The mass times the acceleration is proportional to the force :

$$(1) \quad ma \propto f \quad \text{or} \quad ma = \lambda f.$$

The factor λ is a physical constant. Its value depends on the units we employ. If these are the English units: foot, pound (mass), second, and pound (weight), λ has the value 32:

$$(2) \quad ma = 32f.$$

Furthermore, since $v = \frac{ds}{dt}$, we have:

$$\alpha = \frac{dv}{dt} = \frac{d^2s}{dt^2}.$$

In applying the Second Law we are to regard a force which tends to increase s as positive, one that tends to decrease s as negative.

If forces oblique to the line of motion* act on the body, each one must be broken up into a component along the line of motion and one perpendicular to this line. The latter component has no influence on the motion; the former component tends to produce motion. The force f of Newton's Second Law is obtained, when several forces act simultaneously, as the algebraic sum of all forces and components of forces along the line of motion, taken positive when they tend to increase s , negative in the other case. The body is thought of as moving without rotation and may, therefore, be conceived as a particle.

Finally, we will deduce a new expression for the acceleration. If in the equation

$$\alpha = \frac{dv}{dt} = \frac{dv}{ds} \frac{ds}{dt},$$

replace ds/dt by its value, v . Hence

$$(3) \quad \alpha = v \frac{dv}{ds}.$$

Example 1. A freight train weighing 200 tons is drawn by a locomotive that exerts a pull of 9 tons. 5 tons of this force are expended in overcoming frictional resistances. How much speed will the train have acquired at the end of a minute?

* We are considering here only the case of rectilinear motion or constrained motion in a given curve. For a more general statement of the law cf. § 9.

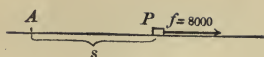

FIG. 58

Here we have

$$m = 200 \times 2000 = 400,000 \text{ lbs.},$$

$$f = 9 \times 2000 - 5 \times 2000 = 8000 \text{ lbs.}^*$$

and hence (2) becomes

$$400,000 \frac{dv}{dt} = 32 \times 8000,$$

or

$$\frac{dv}{dt} = \frac{16}{25}.$$

Integrating with respect to t , we get:

$$v = \frac{16}{25}t + C.$$

Since $v = 0$ when $t = 0$, we must have $C = 0$, and hence

$$v = \frac{16}{25}t.$$

At the end of a minute, $t = 60$, and so

$$v = \frac{16}{25} \times 60 = 38.4 \text{ ft. per sec.}$$

To reduce feet per second to miles per hour it is convenient to notice that 30 miles an hour is equivalent to 44 ft. a second, as the student can readily verify; or, roughly, 2 miles an hour corresponds to 3 ft. a second. Hence the speed in the present case is two-thirds of 38.4, or 26 miles an hour.

Example 2. A stone is sent gliding over the ice with an initial velocity of 30 ft. a sec. If the coefficient of friction between the stone and the ice is $\frac{1}{10}$, how far will the stone go?

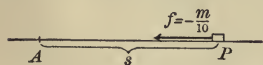

FIG. 59

Here, the only force that we take account of is the retarding force of friction, and this amounts to one-tenth of a pound of force for every pound

of mass there is in the stone. Hence, if there are m pounds of mass in the stone the force will be $\frac{1}{10}m$ lbs.,† and since it tends to decrease s , it is to be taken as negative:

*The student must distinguish carefully between the two meanings of the word *pound*, namely (a) a *mass*, and (b) a *force*; — two totally different physical objects. Thus a pound of lead is a certain quantity of *matter*. If it is hung up by a string, the tension in the string is a pound of *force*.

† The student should notice that m is neither a mass nor a force, but a *number*, like all the other letters of Algebra, the Calculus, and Physics.

$$m\alpha = 32\left(-\frac{m}{10}\right),$$

$$\alpha = -\frac{16}{5}.$$

Now what we want is a relation between v and s , for the question is: How *far* ($s = ?$), when the stone *stops* ($v = 0$). So we use the value (3) of α :

$$v \frac{dv}{ds} = -\frac{16}{5},$$

or
$$v dv = -\frac{16}{5} ds.$$

Hence
$$\frac{v^2}{2} = -\frac{16}{5}s + C.$$

To determine C we have the data that, when $s = 0$, $v = 30$:

$$\frac{30^2}{2} = 0 + C, \quad C = 450,$$

$$v^2 = 900 - \frac{32}{5}s.$$

When the stone stops, $v = 0$, and we have

$$0 = 900 - \frac{32}{5}s, \quad s = 141 \text{ ft.}$$

EXERCISES *

1. An ice boat that weighs 1000 pounds is driven by a wind which exerts a force of 35 pounds. Find how fast it is going at the end of 30 seconds if it starts from rest.

Ans. About 22 miles an hour.

2. A small boy sees a slide on the ice ahead, and runs for it. He reaches it with a speed of 8 miles an hour and slides 15 feet. How rough are his shoes, *i.e.* what is the coefficient of friction between his shoes and the ice? *Ans.* $\mu = .15$.

3. Show that, if the coefficient of friction between a sprinter's shoes and the track is $\frac{1}{12}$, his best possible record in a hundred yard dash cannot be less than 15 seconds.

* The student is expected in these and in all the other exercises in mechanics to draw a figure for each exercise and to mark the forces distinctly in it, preferably in red ink.

4. An electric car weighing 12 tons gets up a speed of 15 miles an hour in 10 seconds. Find the average force that acts on it, *i.e.* the constant force which would produce the same velocity in the same time.

5. In the preceding problem, assume that the given speed is acquired after running 200 feet. Find the time required and the average force.

6. A train weighing 500 tons and running at the rate of 30 miles an hour is brought to rest by the brakes after running 600 feet. While it is being stopped it passes over a bridge. Find the force with which the bridge pulls on its anchorage.

Ans. 25.2 tons.

7. An electric car is starting on an icy track. The wheels skid and it takes the car 15 seconds to get up a speed of two miles an hour. Compute the coefficient of friction between the wheels and the track.

2. Absolute Units of Force. The units in terms of which we measure mass, space, time, and force are arbitrary. If we change one of them we thereby change the value of λ in Newton's Second Law, (1). Consequently, by changing the unit of force properly, the units of mass, space, and time being held fast, we can make $\lambda = 1$. Hence the

DEFINITION. The absolute unit of force is that unit that makes $\lambda = 1$ in Newton's Second Law of Motion, (1):*

$$(4) \quad ma = f.$$

* We have already met a precisely similar question twice in the Calculus. In differentiating the function $\sin x$ we obtain the formula

$$D_x \sin x = \cos x$$

only when we measure angles in radians. Otherwise the formula reads

$$D_x \sin x = \lambda \cos x.$$

In particular, if the unit is a degree, $\lambda = \pi/180$. We may, therefore, define a radian as follows: The absolute unit of angle (the radian) is that unit that makes $\lambda = 1$ in the above equation.

In order to determine experimentally the absolute unit of force, we may allow a body to fall freely and observe how far it goes in a known time. Let the number g be the number of absolute units of force with which gravity attracts the unit of mass. Then the force, measured in absolute units, with which gravity attracts a body of m units of mass will be mg . Newton's Second Law (4) now becomes:

$$m \frac{dv}{dt} = mg, \quad \text{hence} \quad \frac{dv}{dt} = g;$$

$$v = gt + C, \quad C = 0;$$

$$v = \frac{ds}{dt} = gt,$$

$$s = \frac{1}{2}gt^2 + K, \quad K = 0,$$

and we have the law for freely falling bodies deduced directly from Newton's Second Law of Motion, the hypothesis being merely that the force of gravity is constant. Substituting in the last equation the observed values $s = S$, $t = T$, we get:

$$g = \frac{2S}{T^2}.$$

If we use English units for mass, space, and time, g has, to two significant figures, the value 32, *i.e.* the absolute unit of force in this system, a *poundal*, is equal nearly to *half an ounce*. If we use c.g.s. units, g ranges from 978 to 983 at different parts of the earth, and has in Cambridge the value 980. The absolute unit of force in this system is called the *dyne*.

Since g is equal to the acceleration with which a body falls

Again, in differentiating the logarithm, we found

$$D_x \log_a x = (\log_a e) \frac{1}{x}.$$

This multiplier reduces to unity when we take $a = e$. Hence the definition: The absolute (natural) base of logarithms is that base which makes the multiplier $\log_a e$ in the above equation equal to unity.

freely under the attraction of gravity, g is called the *acceleration of gravity*. But this is not our definition of g ; it is a theorem about g that follows from Newton's Second Law of Motion.

The student can now readily prove the following theorem, which is often taken as the definition of the absolute unit of force in elementary physics: The absolute unit of force is that force which, acting on the unit of mass for the unit of time, generates the unit of velocity.

Example 1. A body is projected down an inclined plane with an initial velocity of v_0 feet per second. Determine the motion completely.

The forces which act are: the component of gravity, $mg \sin \gamma$ absolute units, down the plane, and the force of friction, $\mu R = \mu mg \cos \gamma$ up the plane. Hence

$$ma = mg \sin \gamma - \mu mg \cos \gamma$$

$$\text{or} \quad \frac{dv}{dt} = g \sin \gamma - \mu g \cos \gamma.$$

Integrating this equation, we get

$$v = g (\sin \gamma - \mu \cos \gamma) t + C,$$

$$v_0 = 0 + C,$$

$$(A) \quad v = \frac{ds}{dt} = g (\sin \gamma - \mu \cos \gamma) t + v_0.$$

A second integration gives

$$(B) \quad s = \frac{1}{2} g (\sin \gamma - \mu \cos \gamma) t^2 + v_0 t,$$

the constant of integration here being 0.

To find v in terms of s we may eliminate t between (A) and (B). Or we can begin by using formula (3) for the acceleration:

$$v \frac{dv}{ds} = g (\sin \gamma - \mu \cos \gamma),$$

$$\frac{1}{2} v^2 = g (\sin \gamma - \mu \cos \gamma) s + K,$$

$$\frac{1}{2} v_0^2 = 0 + K,$$

$$v^2 = 2g (\sin \gamma - \mu \cos \gamma) s + v_0^2.$$

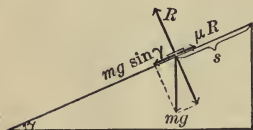

FIG. 6J

Example 2. An Atwood's machine has equal weights, M and M , attached to the cord, and a rider of mass m is added to one of the weights. Determine the motion.

We apply Newton's Second Law to each of the weights M and $M + m$ individually. The forces are indicated in the diagram, the tension in the string, whose weight is negligible, being the same at all points. Moreover, since the space traversed by both weights is the same, s , their velocities and accelerations are also equal. Thus

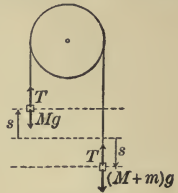

FIG. 61

$$\begin{aligned}
 M\alpha &= T - Mg, \\
 (M + m)\alpha &= (M + m)g - T, \\
 \therefore \alpha &= \frac{mg}{2M + m}, \quad T = \frac{(2M + 2m)M}{2M + m}g.
 \end{aligned}$$

From the last formula it appears that the tension is constant and that it lies between the values Mg and $(M + m)g$. The student can work out for himself the formulas that give v and s in terms of t , and v in terms of s .

EXERCISES *

1. A weightless cord passes over a smooth pulley and carries weights of 8 and 9 pounds at its ends. The system starts from rest. Find how far the 9 pound weight will descend before it has acquired a velocity of one foot a second. What is the tension in the cord? *Ans.* $\frac{17}{4}$ ft.; 8.4 lbs.

2. Obtain the usual formulas for the motion of a body projected vertically :

$$\begin{aligned}
 v^2 &= 2gs + v_0^2 & \text{or} & & = -2gs + v_0^2; \\
 v &= gt + v_0 & \text{or} & & = -gt + v_0; \\
 s &= \frac{1}{2}gt^2 + v_0t & \text{or} & & = -\frac{1}{2}gt^2 + v_0t.
 \end{aligned}$$

3. On the surface of the moon a pound weighs only one sixth as much as on the surface of the earth. If a mouse can jump

* See foot note on p. 193.

up 1 foot on the surface of the earth, how high could it jump on the surface of the moon? Compare the time it is in the air in the two cases.

4. A bullet fired from a revolver penetrates a block of wood to a distance of 6 inches. How much greater would its velocity have to be to make it go in 12 inches? Assume the resistance to be the same at all points, for all velocities.

Ans. About 40 percent.

5. Regarding the big locomotive exhibited at the World's Fair in 1904 by the Baltimore and Ohio Railroad the *Scientific American* says: "Previous to sending the engine to St. Louis, the engine was tested at Schenectady, where she took a 63-car train weighing 3,150 tons up a one-per-cent. grade."

Find how long it would take the engine to develop a speed of 15 m. per h. in the same train on the level, starting from rest, the draw-bar pull being assumed to be the same as on the grade.

6. A block of iron weighing 100 pounds rests on a smooth table. A cord, attached to the iron, runs over a smooth pulley at the edge of the table and carries a weight of 15 pounds, which hangs vertically. The system is released with the iron 10 feet from the pulley. How long will it be before the iron reaches the pulley, and how fast will it be moving?

Ans. 2.19 sec.; 9.1 ft. a sec.

7. Solve the same problem on the assumption that the table is rough, $\mu = \frac{1}{20}$, and that the pulley exerts a constant retarding force of 4 ounces.

8. If Sir Isaac Newton registered 170 pounds on a spring balance in an elevator at rest, and if, when the elevator was moving, he weighed only 169 pounds, what inference would he draw about the motion of the elevator?

9. What does a man whose weight is 180 pounds weigh in an elevator that is descending with an acceleration of 2 feet per second per second?

10. A chest-weight consists of a movable pulley and a fixed pulley, as shown in the diagram. If a 16 pound weight is attached to the movable pulley and if the cord carries a 9 pound weight at its free end, how far will the 9 pound weight descend before it has acquired a velocity of one foot a second? What is the tension in the cord? *Ans.* $\frac{13}{8}$ ft.; 8.3 lbs.



FIG. 62

11. In a system of pulleys like that of question 10 a 4 pound weight is attached to the movable pulley, and to the free end of the cord is fastened a weight of 1 pound and 15 ounces, and in addition a rider weighing 2 ounces is laid on. The system starts from rest, and after the rider has descended 8 feet it is removed. Determine the motion.

12. A bucket of water, at the bottom of which there rests a stone, forms one weight of an Atwood's machine. The bucket with its contents weighs 16 pounds, and the other weight is 18 pounds. If the stone weighs 12 pounds and its specific gravity is 3, find how hard it presses on the bottom of the bucket when the system is released.

13. In the bucket described in the preceding question there is a cork, of specific gravity $\frac{1}{4}$, submerged and held under by a thread tied to the bottom of the bucket. Will the tension in the thread be increased or diminished after the system is released?

14. What is the mechanical effect on one's stomach when one is in an elevator which, starting from rest, is allowed suddenly to descend?

15. A block of ice is resting on a sled, the coefficient of friction between the ice and the sled being $\frac{1}{5}$. The sled is drawn along, starting from rest. Find the shortest possible time in which the ice can be moved 10 ft.

16. A man weighing 180 pounds is at the top of a building 60 feet above the ground. He has a rope which just reaches

to the ground and which can bear a strain of only 170 pounds. Can he slide down the rope to the ground in safety?

Interpret the velocity with which he reaches the ground by finding the height from which he would have to drop in order to acquire the same velocity.

17. Find the shortest time in which a bale weighing 160 pounds can be raised from the ground to a window 25 feet high (coming to rest at the window) by means of the rope of the preceding question, if the rope passes over a fixed pulley just above the window and is drawn in over the drum of a dummy engine.

18. If the speed of a train is being uniformly retarded by the brakes, prove that a plumb line will hang at rest relatively to the train at a certain angle, and determine this angle.

19. In the train described in the preceding exercises, question 6, there is a bucket of water. Find the angle which the surface of the water makes with the plane of the tracks after the water has ceased to surge.

20. At what angle ought a man to stand in a car that is starting with an acceleration of 3 feet per second per second?

21. The drivers of a locomotive are keyed to the axle and are being transported on a platform car. The axle is perpendicular to the track, the diameter of the wheels is 6 ft., and they are blocked by pieces of joist 3 in. thick. The brakes being put on hard, so that the train loses $3\frac{1}{2}$ miles an hour of speed every second, find whether the drivers will jump the cleats.

22. A body slides down a smooth inclined plane. Show that the velocity with which it reaches the foot of the plane is the same that the body would have acquired in falling freely through the same difference in level.

23. Chords are drawn from the highest point O of a vertical circle. Show that the time of descent of a bead from rest at

O , down a smooth wire coinciding with any one of these chords, is constant.

24. A point O is distant 10 feet from an inclined plane, whose angle of inclination is α . Find the shortest time in which a bead can reach the plane if it starts from rest at O and slides down a smooth straight wire.

25. The draw bar of the locomotive in Example 5 weighs 50 pounds. How much harder does the engine pull on the draw bar than the draw bar pulls on the train?

3. Simple Harmonic Motion. *Problem.* One end of an elastic string is made fast at a point A and to the other end is fastened a weight. The weight is carefully brought to rest and then is given a slight vertical displacement. Determine the motion.

Let AB be the natural length of the string, O the point of equilibrium of the weight, and let P be the position of the weight at any instant after it is released; C , the point from which it is released. The forces that act on it are: the force of gravity, mg , downward and the tension T of the string upward, — we neglect the damping due to the atmosphere. Hence we have from Newton's Second Law of Motion

$$(5) \quad m \frac{d^2 s}{dt^2} = T - mg.$$

From Hooke's law, which says that the tension in a stretched elastic string is proportional to the stretching, it follows that

$$(6) \quad T = \lambda \frac{BP}{l},$$

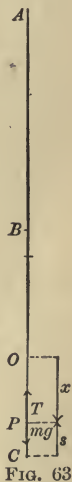

FIG. 63

where λ is Young's modulus,* provided the cross-section of the

* The physical constant λ is sometimes interpreted as that force which would be required to double the length of the string, provided this could be done without exceeding the elastic limit.

string is unity. Since at O the tension is just equal to the force of gravity, we have furthermore

$$(7) \quad mg = \lambda \frac{BO}{l}.$$

Hence from (6) and (7):

$$T - mg = \lambda \frac{BP - BO}{l} = \lambda \frac{x}{l},$$

and thus (5) becomes

$$(8) \quad m \frac{d^2s}{dt^2} = \lambda \frac{x}{l}.$$

The variables s and x are connected by the relation:

$$s + x = OC = h,$$

where h denotes the original displacement. Thus

$$\frac{ds}{dt} + \frac{dx}{dt} = 0 \quad \text{or} \quad \frac{ds}{dt} = -\frac{dx}{dt}$$

and

$$\frac{d^2s}{dt^2} = -\frac{d^2x}{dt^2}.$$

Substituting in (8) we get

$$\frac{d^2x}{dt^2} = -\frac{\lambda}{ml}x,$$

or, setting $\lambda/ml = n^2$:

$$(I) \quad \frac{d^2x}{dt^2} = -n^2x.$$

This differential equation is characteristic for *Simple Harmonic Motion*.

To integrate (I) multiply through by $2dx/dt$ and note that*

$$\frac{d}{dt} \frac{dx^2}{dt^2} = 2 \frac{dx}{dt} \frac{d^2x}{dt^2}.$$

We have, then:

$$2 \frac{dx}{dt} \frac{d^2x}{dt^2} = -2n^2x \frac{dx}{dt}.$$

* This method is evidently applicable to any differential equation of the form:

$$\frac{d^2y}{dx^2} = f(y).$$

Integrating each side with respect to t we get :

$$\frac{dx^2}{dt^2} = \int -2n^2x \frac{dx}{dt} dt = -2n^2 \int x dx = -n^2x^2 + C.$$

To determine C observe that initially $x = h$, while the velocity, equal numerically to dx/dt , is 0 :

$$0 = -n^2h^2 + C.$$

Hence

$$(II) \quad \frac{dx^2}{dt^2} = n^2(h^2 - x^2).$$

From this result we infer (a) that the maximum velocity is attained when $x = 0$ and is nh ; (b) that the height to which the body rises, determined by putting $dx/dt = 0$ in (II), corresponds to $x = -h$. The latter inference, however, is legitimate only on the assumption that the point C : $x = -h$, is not higher than B , i.e. that

$$OC \leq OB.$$

For otherwise the body will rise above B , and since the string cannot push, a new law of force becomes operative, the force now being simply that of gravity, and so (I) is no longer true.

We return to equation (II) and write it in the form

$$\frac{dx}{dt} = -n\sqrt{h^2 - x^2},$$

the minus sign holding so long as the body is rising, since x decreases as t increases. To integrate this equation write it as follows:

$$n dt = -\frac{dx}{\sqrt{h^2 - x^2}}.$$

Hence

$$nt = -\int \frac{dx}{\sqrt{h^2 - x^2}} = \cos^{-1} \frac{x}{h} + C.$$

Initially $t = 0$ and $x = h$, therefore

$$0 = 0 + C$$

and we have

$$(9) \quad nt = \cos^{-1} \frac{x}{h},$$

hence

$$(III) \quad x = h \cos nt.$$

We have deduced this result merely for the interval that the body is rising. When the body begins to descend, dx/dt becomes positive and we have

$$nt = + \int \frac{dx}{\sqrt{h^2 - x^2}}.$$

This integral can, however, still be expressed by the formula

$$(10) \quad nt = \cos^{-1} \frac{x}{h} + C,$$

provided that, contrary to our usual agreement, we choose that determination of the multiple-valued function which lies between π and 2π . To determine C we have from (9) that when $x = -h$, $t = \pi/n$. Substituting these values in (10) we get

$$\pi = \cos^{-1}(-1) + C, \quad C = 0,$$

and thus (9) and (III) hold throughout the descent. From this point on the motion repeats itself, — a fact that is mirrored analytically in equation (III) by the *periodicity* of the function $\cos nt$. Thus formula (III) holds without restriction.

Turning now to a detailed discussion of these results we see that the time from C to O is $t_1 = \pi/2n$. The same time is also required from O to C' , then from C' back to O , and lastly from O to C . Thus the total time from C back to C is

$$T = \frac{2\pi}{n}.$$

In descending, the velocity is the same in magnitude as when the body was going up, only reversed in sense; and the time required to descend from C' to an arbitrary point P is the same as that required to rise from P to C' .

The time T is called the *period* of the oscillation. If we consider the body at an arbitrary point P and time t , then at

the instant T seconds later, the body will be at the same point and moving with the same velocity, both in magnitude and sense,—this fact is expressed by saying that the *phase* is the same,—for

$$x = h \cos n \left(t + \frac{2\pi}{n} \right) = h \cos nt,$$

$$\frac{dx}{dt} = -hn \sin n \left(t + \frac{2\pi}{n} \right) = -hn \sin nt.$$

Finally, we observe that the amplitude $2h$ of the oscillation has no effect on the period.

EXERCISES

1. One end of an elastic string is fastened at a point A , and to the other end is attached a weight that would just double the length of the string. The weight being dropped from A , find how far it will descend.

Assume the string to be 3 feet long and the mass of the weight to be 2 pounds. *Ans.* 11.2 ft.

2. If the weight in the preceding question is brought to a point 9 feet below A and released, how high will it rise? How long will it take for it to return to the starting point?

3. A slender rod is clamped at one end so as to be horizontal when not loaded. A ball of lead is then fastened to the free end and brought carefully to the position of equilibrium, the ball dropping by less than 3% of the length of the rod. The ball being given a slight vertical displacement, show that the oscillation will be approximately simple harmonic motion and determine the period.

Neglect the deviation of the path of the ball from a vertical straight line, and assume that the force that the rod exerts is proportional to the distance which the free end has been displaced from equilibrium.

4. A steel wire of one square millimeter cross-section is hung up in Bunker Hill Monument, and a weight of 25 kilo-

grammes is fastened to its lower end and carefully brought to rest. The weight is then given a slight vertical displacement. Determine the period of the oscillation.

Given that the force required to double the length of the wire is 21,000 kilogrammes, and that the length of the wire is 210 feet. *Ans.* A little over half a second.

4. Motion under the Attraction of Gravitation. *Problem.*

To find the velocity which a stone acquires in falling to the earth from interstellar space.

Assume the earth to be at rest and consider only the force which the earth exerts. Let r be the distance of the stone from the centre O of the earth, and s , the distance it has travelled from the starting point A . Then the force acting on it is

$$f = \frac{\lambda}{r^2},$$

and since $f = mg$ when $r = R$, the radius of the earth:

$$mg = \frac{\lambda}{R^2} \quad \text{and} \quad f = \frac{mgR^2}{r^2}.$$

Hence, from Newton's Second Law of Motion,

$$(11) \quad m \frac{d^2 s}{dt^2} = \frac{mgR^2}{r^2}.$$

Furthermore, $s + r = l$, where l denotes the initial distance OA , and consequently

$$\frac{ds}{dt} + \frac{dr}{dt} = 0, \quad \frac{d^2 s}{dt^2} + \frac{d^2 r}{dt^2} = 0.$$



FIG. 64

Equation (11) thus becomes :

$$(a) \quad \frac{d^2 r}{dt^2} = - \frac{gR^2}{r^2}.$$

To integrate this equation, we employ the method of § 3 and multiply by $2 dr/dt$:

$$2 \frac{dr}{dt} \frac{d^2 r}{dt^2} = - \frac{2gR^2}{r^2} \frac{dr}{dt}.$$

Integrating with respect to t we get:

$$\frac{dr^2}{dt^2} = -2gR^2 \int \frac{dr}{r^2} = \frac{2gR^2}{r} + C.$$

Initially $dr/dt = 0$ and $r = l$:

$$0 = \frac{2gR^2}{l} + C, \quad C = -\frac{2gR^2}{l}.$$

$$(b) \quad \frac{dr^2}{dt^2} = 2gR^2 \left(\frac{1}{r} - \frac{1}{l} \right).$$

Since dr/dt is numerically equal to the velocity ds/dt , the velocity V at the surface of the earth is given by the equation:

$$V^2 = 2gR^2 \left(\frac{1}{R} - \frac{1}{l} \right).$$

If l is very great, the last term in the parenthesis is small, and so, no matter how great l is, V can never quite equal $\sqrt{2gR}$. Here $g = 32$, $R = 4000 \times 5280$, and hence the velocity in question is about 36,000 feet, or 7 miles, a second.

This solution neglects the retarding effect of the atmosphere; but as the atmosphere is very rare at a height of 50 miles from the earth's surface, the result is reliable down to a point comparatively near the earth.

In order to find the time it would take the stone to fall, write (b) in the form

$$\frac{dr}{dt} = -\sqrt{2gR^2} \sqrt{\frac{l-r}{lr}}.$$

Hence
$$dt = -\frac{\sqrt{l}}{8R} \frac{r dr}{\sqrt{lr-r^2}}$$

and
$$t = -\frac{\sqrt{l}}{8R} \int \frac{r dr}{\sqrt{lr-r^2}}.$$

Turning to the *Tables*, No. 169, we find

$$\int \frac{r dr}{\sqrt{lr-r^2}} = -\sqrt{lr-r^2} + \frac{l}{2} \int \frac{dr}{\sqrt{lr-r^2}}$$

$$= -\sqrt{lr-r^2} + \frac{l}{2} \sin^{-1} \frac{2r-l}{l} + K.$$

Thus
$$t = \frac{\sqrt{l}}{8R} \left\{ \sqrt{lr-r^2} - \frac{l}{2} \sin^{-1} \frac{2r-l}{l} \right\} + K'.$$

Initially $t=0$ and $r=l$:

$$0 = \frac{\sqrt{l}}{8R} \left\{ 0 - \frac{l}{2} \frac{\pi}{2} \right\} + K'.$$

Hence finally:

$$t = \frac{\sqrt{l}}{8R} \left\{ \sqrt{lr-r^2} + \frac{l}{2} \left[\frac{\pi}{2} - \sin^{-1} \frac{2r-l}{l} \right] \right\},$$

(c)
$$t = \frac{\sqrt{l}}{8R} \left\{ \sqrt{lr-r^2} + \frac{l}{2} \cos^{-1} \frac{2r-l}{l} \right\}.$$

EXERCISES

1. A hole is bored through the centre of the earth and a stone is dropped in. Find how long it will take the stone to reach the centre and how fast it will be going when it gets there.

Assume that the air has been exhausted from the hole and that the attraction of the earth is proportional to the distance from the centre.

2. Show that if the earth were without an atmosphere and a stone were projected from the surface of the earth with a velocity of $\sqrt{2gR}$, or nearly seven miles a second, it would never come back.

3. The moon's mass is about $\frac{1}{81}$ and its radius about $\frac{3}{11}$ that of the earth. With what velocity would a body have to be projected from the moon in order not to return?

4. Taking the distance of the moon from the earth as 237,000 miles, find the velocity with which a stone would reach the moon if it were placed at the point of no force between these two bodies and then slightly displaced in the direction of the moon.

5. Find how long it would take Saturn to fall to the sun. Given that the acceleration of gravity on the surface of the sun is 905 feet per second per second, that the diameter of the sun is 860,000 miles, and that the distance of Saturn from the sun is 880,000,000 miles.

6. How long would it take the earth to fall to the sun? Given that the distance from the earth to the sun is 92,000,000 miles.

7. How long would it take the moon to fall to the earth?

5. Constrained Motion. If a particle is constrained to describe a given path, as in the case, for example, of a simple pendulum, then the form which Newton's Second Law of Motion assumes is that the product of the mass by the acceleration along the path is equal to the component, along the path, of the resultant of all the forces that act.

Consider the simple pendulum. Here

$$m \frac{d^2 s}{dt^2} = -mg \sin \theta,$$

and since $s = l\theta$,

$$(A) \quad \frac{d^2 \theta}{dt^2} = -\frac{g}{l} \sin \theta.$$

This differential equation is characteristic for *Simple Pendulum Motion*. We can obtain a first integral by the method of § 3 :

$$\begin{aligned} 2 \frac{d\theta}{dt} \frac{d^2 \theta}{dt^2} &= -\frac{2g}{l} \sin \theta \frac{d\theta}{dt}, \\ \frac{d\theta^2}{dt^2} &= -\frac{2g}{l} \int \sin \theta d\theta = \frac{2g}{l} \cos \theta + C, \\ 0 &= \frac{2g}{l} \cos \alpha + C, \end{aligned}$$

where α is the initial angle; hence

$$(B) \quad \frac{d\theta^2}{dt^2} = \frac{2g}{l} (\cos \theta - \cos \alpha).$$



FIG. 65

The velocity in the path at the lowest point is l times the angular velocity for $\theta = 0$, or $\sqrt{2gl(1 - \cos \alpha)}$, and is the same that would have been acquired if the bob had fallen freely under the force of gravity through the same difference in level.

If we attempt to obtain the time by integrating (B), we are led to the equation :

$$t = \sqrt{\frac{l}{2g}} \int \frac{d\theta}{\sqrt{\cos \theta - \cos \alpha}}.$$

This integral cannot be expressed in terms of the functions at present at our disposal. It is an Elliptic Integral. When θ , however, is small, $\sin \theta$ differs from θ by only a small percentage of either quantity, Chap. IV, § 1, and hence we may expect to obtain a good approximation to the actual motion if we replace $\sin \theta$ in (A) by θ :

$$(A') \quad \frac{d^2\theta}{dt^2} = -\frac{g}{l}\theta.$$

This latter equation is of the type of the differential equation of Simple Harmonic Motion, § 3, (I), n^2 having here the value g/l . Hence when a simple pendulum swings through a small amplitude, its motion is approximately harmonic and its period is approximately

$$T = 2\pi\sqrt{\frac{l}{g}}.$$

A question that interested the mathematicians of the eighteenth century was this: In what curve should a pendulum swing in order that the period of oscillation may be absolutely independent of the amplitude? It turns out that the cycloid has this property. For the differential equation of motion is

$$m \frac{d^2s}{dt^2} = -mg \sin \tau,$$

where s is measured from the lowest point, and since, from Ex. 8, p. 151,

$$s = 4a \sin \tau,$$

we have $\frac{d^2 s}{dt^2} = -\frac{g}{4a} s.$

This is the differential equation of Simple Harmonic Motion, § 3, (I), and hence the period of the oscillation :

$$T = 2\pi \sqrt{\frac{4a}{g}} = 4\pi \sqrt{\frac{a}{g}},$$

is independent of the amplitude.

A cycloid pendulum may be constructed by causing the cord of the pendulum to wind on the evolute of the path. But the resistances due to the stiffness of the cord as it winds up and unwinds would be appreciable.

We will close this paragraph with a general theorem. Suppose a bead slides on a smooth wire of any shape whatever. Then its velocity at any point will be the same as what the bead would have acquired in falling freely under the force of gravity the same difference in level.

We have already met special cases of this theorem in the inclined plane and the simple pendulum. We shall restrict ourselves to plane curves, but the proof can be extended without difficulty to twisted curves.

Newton's Second Law of Motion gives

$$m \frac{d^2 s}{dt^2} = mg \cos \tau = mg \frac{dx}{ds},$$

Hence $2 \frac{ds}{dt} \frac{d^2 s}{dt^2} = 2g \frac{dx}{ds} \frac{ds}{dt} = 2g \frac{dx}{dt},$

$$\frac{ds^2}{dt^2} = 2gx + C.$$

If we suppose the bead to start from rest at A , then

$$0 = 2gx_0 + C,$$

$$(2) \quad \therefore v^2 = \frac{ds^2}{dt^2} = 2g(x - x_0).$$

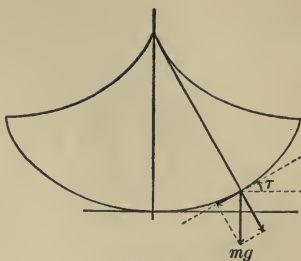

FIG. 66

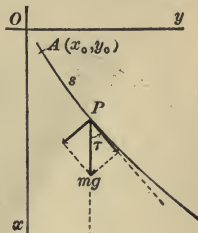

FIG. 67

But the velocity that a body falling freely a distance of $x - x_0$ attains is expressed by precisely the same formula, and thus the theorem is established.

In the more general case that the bead passes the point A with a velocity v_0 we have :

$$v_0^2 = 2gx_0 + C,$$

$$(A') \quad v^2 - v_0^2 = 2g(x - x_0).$$

Thus it is seen that the velocity at P is the same that the bead would have acquired at the second level if it had been projected vertically from the first with velocity v_0 .

The theorem also asserts that the sum of the kinetic and potential energies of the bead is constant, or that the change in kinetic energy is equal to the work done on the bead.

If the bead starts from rest at A , it will continue to slide till it reaches the end of the wire or comes to a point A' at the same level as A . In the latter case it will in general just rise to the point A' and then retrace its path back to A . But if the tangent to the curve at A' is horizontal, the bead may approach A' as a limiting position without ever reaching it.



FIG. 68

EXERCISES

1. A bead slides on a smooth vertical circle. It is projected from the lowest point with a velocity equal to that which it would acquire in falling from rest from the highest point. Show that it will approach the highest point as a limit which it will never reach.

2. From the general theorem (A) deduce the first integral (B) of the differential equation (A).

6. **Motion in a Resisting Medium.** When a body moves through the air or through the water, these media oppose resistance, the magnitude of which depends on the velocity, but

does not follow any simple mathematical law. For low velocities up to 5 or 10 miles per hour, the resistance R can be expressed approximately by the formula:

$$(12) \quad R = av,$$

where a is a constant depending both on the medium and on the size and shape of the body, but not on its mass. For higher velocities up to the velocity of sound (1082 ft. a sec.) the formula

$$(13) \quad R = cv^2$$

gives a sufficient approximation for many of the cases that arise in practice. We shall speak of other formulas at the close of the paragraph.

Problem 1. A man is rowing in still water at the rate of 3 miles an hour, when he ships his oars. Determine the subsequent motion of the boat.

Here Newton's Second Law gives us:

$$(14) \quad m \frac{dv}{dt} = -av,$$

$$dt = -\frac{m}{a} \frac{dv}{v},$$

$$(15) \quad t = \frac{m}{a} \log \frac{v_0}{v},$$

where v_0 is the initial velocity, nearly $4\frac{1}{2}$ ft. a sec.

From (15) we get:

$$(16) \quad v = v_0 e^{-\frac{at}{m}}.$$

Hence it might appear that the boat would never come to rest but would move more and more slowly, since

$$\lim_{t \rightarrow \infty} e^{-\frac{at}{m}} = 0.$$

We warn the student strictly, however, against such a conclusion. For the approximation we are using, $R = av$, holds only

for a limited time and even for that time is at best an *approximation*. It will probably not be many minutes before the boat is drifting sidewise, and the value of a for this aspect of the boat would be quite different, — if indeed the approximation $R = av$ could be used at all.

To determine the distance travelled, we have from (14):

$$mv \frac{dv}{ds} = -av,$$

and consequently:

$$(17) \quad v = v_0 - \frac{a}{m}s.$$

Hence, even if the above law of resistance held up to the limit, the boat would not travel an infinite distance, but would approach a point distant

$$S = \frac{mv_0}{a}$$

feet from the starting point, the distance traversed thus being proportional to the initial momentum.

Finally, to get a relation between s and t , integrate (16):

$$(18) \quad \begin{aligned} \frac{ds}{dt} &= v_0 e^{-\frac{at}{m}}, \\ s &= \frac{mv_0}{a} (1 - e^{-\frac{at}{m}}). \end{aligned}$$

From this result is also evident that the boat will never cover a distance of S ft. while the above approximation lasts.

EXERCISE

If the man and the boat together weigh 300 lbs. and if a steady force of 3 lbs. is just sufficient to maintain a speed of 3 miles an hour in still water, show that when the boat has gone 20 ft., the speed has fallen off by a little less than a mile an hour.

Problem 2. A drop of rain falls from a cloud with an initial velocity of v_0 ft. a sec. Determine the motion.

We assume that the drop is already of its final size, — not

gathering further moisture as it proceeds, — and take as the law of resistance :

$$R = cv^2.$$

Hence

$$m \frac{dv}{dt} = mg - cv^2,$$

$$v \frac{dv}{ds} = \frac{mg - cv^2}{m},$$

$$ds = \frac{mvdv}{mg - cv^2},$$

$$s = -\frac{m}{2c} \log (mg - cv^2) + C,$$

$$0 = -\frac{m}{2c} \log (mg - cv_0^2) + C,$$

and thus finally

$$(19) \quad s = \frac{m}{2c} \log \frac{mg - cv_0^2}{mg - cv^2}.$$

Solving for v we have

$$e^{\frac{2cs}{m}} = \frac{mg - cv_0^2}{mg - cv^2},$$

$$(20) \quad v^2 = \frac{mg}{c} - \frac{mg - cv_0^2}{c} e^{-\frac{2cs}{m}}.$$

When s increases indefinitely, the last term approaches 0 as its limit, and hence the velocity v can never exceed (or quite equal) $\bar{v} = \sqrt{mg/c}$ ft. a sec. This is known as the *limiting velocity*. It is independent of the height and also of the initial velocity, and is practically attained by the rain as it falls, for a rain drop is not moving sensibly faster when it reaches the ground than it was at the top of a high building.

EXERCISES

1. Show that if a charge of shot be fired vertically upward, it will return with a velocity about $3\frac{1}{2}$ times that of rain drops of the same size; and that if it be fired directly downward

from a balloon two miles high, the velocity will not be appreciably greater.

2. Find the time in terms of the velocity and the velocity in terms of the time in Problem 2.

3. Determine the height to which the shot will rise in Ex. 1, and show that the time to the highest point is

$$t = \sqrt{\frac{m}{gc}} \tan^{-1} \left(v_0 \sqrt{\frac{c}{mg}} \right),$$

where v_0 is the initial velocity.

7. Graph of the Resistance. The resistance which the atmosphere or water opposes to a body of a given size and shape can in many cases be determined experimentally with a reasonable degree of precision and thus the graph of the resistance:

$$R = f(v)$$

can be plotted. The mathematical problem then presents itself of representing the curve with sufficient accuracy by means of a simple function of v . In the problem of vertical motion in the atmosphere,

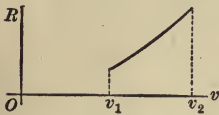

FIG. 69

$$m \frac{dv}{dt} = mg \pm f(v),$$

according as the body is going up or coming down, s being measured positively downward. Now if we approximate to $f(v)$ by means of a quadratic polynomial or a fractional linear function,

$$a + bv + cv^2 \quad \text{or} \quad \frac{\alpha + \beta v}{\gamma + \delta v},$$

we can integrate the resulting equation readily. And it is obvious that we can so approximate, — at least, for a restricted range of values for v .

Another case of interest is that in which the resistance of the medium is the only force that acts:

$$m \frac{dv}{dt} = -f(v).$$

A convenient approximation for the purposes of integration is

$$f(v) = av^b.$$

Here a and b are merely arbitrary constants, enabling us to impose two arbitrary conditions on the curve, — for example, to make it go through two given points, — and are to be determined so as to yield a good approximation to the physical law. Sometimes the simple values $b=1, 2, 3$ can be used with advantage. But we must not confuse these approximate formulas with similarly appearing formulas that represent exact physical laws. Thus, in geometry, the areas of similar surfaces and the volumes of similar solids are proportional to the squares or cubes of corresponding linear dimensions. This law expresses a fact that holds to the finest degree of accuracy of which physical measurements have shown themselves to be capable and with no restriction whatever on the size of the bodies. But the law $R = av^2$ or $R = cv^3$ ceases to hold, *i.e.* to interpret nature within the limits of precision of physical measurements, when v transcends certain restricted limits, and the student must be careful to bear this fact in mind.

EXERCISES

1. Work out the formulas for the motion of the body in each of the above cases.

2. A train weighing 300 tons, inclusive of the locomotive, can just be kept in motion on a level track by a force of 3 pounds to the ton. The locomotive is able to maintain a speed of 60 miles an hour, the horse power developed being reckoned as 1300. Assuming that the frictional resistances are the same at high speeds as at low ones and that the resistance of the air is proportional to the square of the velocity, find by how much the speed of the train will have dropped off in running half a mile if the steam is cut off with the train at full speed.

8. Motion under an Attractive Force with Damping. Let us begin with a concrete example and consider the motion of the particle of § 3 when the resistance of the atmosphere is taken into account. We will assume that this force is proportional to the velocity, $= -kv$. Thus (5) is replaced by

$$(21) \quad m \frac{d^2s}{dt^2} = T - kv - mg,$$

and this equation becomes, on introducing x :

$$(22) \quad \frac{d^2x}{dt^2} + \kappa \frac{dx}{dt} + n^2x = 0,$$

where $\kappa = k/m$, $n^2 = \lambda/ml$.

Differential equations of the type (22) are important in physics. They occur in the problem of the damped vibrations of a swinging magnet, but especially in the case of the suspended coils of d'Arsonval galvanometers. One method, too, of correcting for the influence of the atmosphere on the motion of a pendulum is to assume (a) that the moment of inertia is slightly increased, *i.e.* the length of the equivalent simple pendulum slightly augmented, and (b) that the resistance varies as the velocity. The resulting differential equation is then of the above type.

To *solve* a differential equation is to find a function which, when substituted in, satisfies the equation. By the *order* of a differential equation is meant the order of the highest derivative that enters. Thus (22) is of the second order. As the general solution of a differential equation of the first order we expect to find a function containing one arbitrary constant; as the general solution of a differential equation of the second order, a function containing two arbitrary constants; and so on.

In order to solve (22) we make use of an artifice and inquire whether, in the function

$$(22) \quad x = e^{mt},$$

it may not be possible so to determine m that this function

shall satisfy (21). (The present m has, of course, nothing to do with the earlier m , the mass.) Here

$$\frac{dx}{dt} = me^{mt}, \quad \frac{d^2x}{dt^2} = m^2e^{mt},$$

and thus the left hand side of (21) becomes, on substituting e^{mt} for x :

$$e^{mt}(m^2 + \kappa m + n^2).$$

Hence we see that if m is chosen as either one of the roots of the quadratic equation

$$(23) \quad m^2 + \kappa m + n^2 = 0,$$

$$i.e. \text{ if } m = -\frac{1}{2}\kappa \pm \sqrt{\frac{1}{4}\kappa^2 - n^2},$$

(21) will be satisfied by (22). Both of these roots are negative, and we will denote them by $-m_1, -m_2$; let $m_1 < m_2$.

More generally, the function

$$(24) \quad x = Ae^{-m_1t} + Be^{-m_2t}$$

also satisfies (21), as is shown directly by substituting in; and since it contains two arbitrary constants, it is the general solution of (21) for the case that

$$\frac{1}{4}\kappa^2 - n^2 > 0.$$

This last condition would not be fulfilled in the case of § 3 if the "string" were a steel wire and the weight a piece of lead, for κ would then be very small. It could be realized, however, if the "string" is a spiral spring and the weight is provided with a collar, to act like an inverted parachute and increase the damping. To determine A and B in this case we have that initially $t = 0, x = h$; hence

$$(25) \quad h = A + B.$$

Furthermore, from (24),

$$\frac{dx}{dt} = -m_1Ae^{-m_1t} - m_2Be^{-m_2t},$$

and initially $dx/dt = 0$; hence

$$(26) \quad 0 = m_1 A + m_2 B.$$

From (25) and (26) A and B can at once be determined :

$$A = \frac{m_2 h}{m_2 - m_1}, \quad B = \frac{-m_1 h}{m_2 - m_1},$$

and hence

$$(27) \quad \frac{dx}{dt} = -\frac{m_1 m_2 h}{m_2 - m_1} (e^{-m_1 t} - e^{-m_2 t}).$$

The motion is now completely determined. The particle starts from rest and moves upward with increasing velocity for a time, then slows up and approaches the point $x=0$ as its limit, when $t = \infty$, — practically, of course, reaching this point after a comparatively short time. All this we read off from (24) and (27) :

$$\lim_{t \rightarrow \infty} x = \lim_{t \rightarrow \infty} (A e^{-m_1 t} + B e^{-m_2 t}) = 0;$$

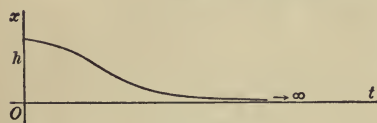

FIG. 70

$$\left. \frac{dx}{dt} \right|_{t=0} = 0, \quad \lim_{t \rightarrow \infty} \frac{dx}{dt} = 0;$$

$$\frac{dx}{dt} < 0, \quad 0 < t < \infty,$$

since $m_1 < m_2$ and consequently

$$e^{-m_1 t} > e^{-m_2 t}.$$

The Case $\frac{1}{4}\kappa^2 - n^2 < 0$. If on the other hand

$$(28) \quad \frac{1}{4}\kappa^2 - n^2 < 0,$$

the solution (24) becomes illusory through the presence of imaginaries in the exponents. Now in the algebra of imaginaries

$$e^{\phi\sqrt{-1}} = \cos \phi + \sqrt{-1} \sin \phi.$$

Hence (24) becomes :

$$x = A e^{-\frac{\kappa}{2} t} (\cos \sqrt{n^2 - \frac{1}{4}\kappa^2} t + \sqrt{-1} \sin \sqrt{n^2 - \frac{1}{4}\kappa^2} t)$$

$$+ B e^{-\frac{\kappa}{2} t} (\cos \sqrt{n^2 - \frac{1}{4}\kappa^2} t - \sqrt{-1} \sin \sqrt{n^2 - \frac{1}{4}\kappa^2} t),$$

and this result can be written in the form

$$(29) \quad x = e^{-\frac{\kappa}{2}t} \left(a \cos \sqrt{n^2 - \frac{1}{4}\kappa^2} t + b \sin \sqrt{n^2 - \frac{1}{4}\kappa^2} t \right),$$

where a and b are constants, to which arbitrary real values can be assigned.

The foregoing explanation, by means of imaginaries, is in no wise essential to the validity of the final formula (29). The student can prove directly that the function (29) really is a solution, no matter what values a and b may have, by actually substituting it in (2).

Another form in which the solution (29) may be written is the following:

$$(30) \quad x = C e^{-\frac{\kappa}{2}t} \sin(\sqrt{n^2 - \frac{1}{4}\kappa^2} t + \gamma),$$

where C and γ are now the constants of integration. Instead of the sine in the last formula the cosine may equally well be written.

Returning to the special problem before us, we have, for the determination of C and γ in (30), initially: $x = h, t = 0$:

$$(31) \quad h = C \sin \gamma.$$

Furthermore,

$$\begin{aligned} \frac{dx}{dt} = C e^{-\frac{\kappa}{2}t} & \left[\sqrt{n^2 - \frac{1}{4}\kappa^2} \cos(\sqrt{n^2 - \frac{1}{4}\kappa^2} t + \gamma) \right. \\ & \left. - \frac{\kappa}{2} \sin(\sqrt{n^2 - \frac{1}{4}\kappa^2} t + \gamma) \right], \end{aligned}$$

and initially $dx/dt = 0$:

$$(32) \quad 0 = C \left[\sqrt{n^2 - \frac{1}{4}\kappa^2} \cos \gamma - \frac{\kappa}{2} \sin \gamma \right].$$

From (32) it follows that

$$\cot \gamma = \frac{\kappa}{2\sqrt{n^2 - \frac{1}{4}\kappa^2}}.$$

If we take the solution that lies in the first quadrant $0 < \gamma < \frac{\pi}{2}$, then, from (31), C will be positive, and we shall have:

$$C = h \csc \gamma = \frac{nh}{\sqrt{n^2 - \frac{1}{4}\kappa^2}}.$$

The accompanying figure represents the curve

$$y = Ce^{-at} \sin (\beta t + \gamma),$$

for the value $\gamma = \pi/4$, and is typical for the whole class of curves (30). The curves cut the axis of abscissas in the points

$$t = \frac{\pi - \gamma + k\pi}{\sqrt{n^2 - \frac{1}{4}\kappa^2}}, \quad k = 0, 1, 2, \dots,$$

and hence the particle passes the point $x = 0$ for the first time $(\pi - \gamma) / \sqrt{n^2 - \frac{1}{4}\kappa^2}$ seconds from the start, and continues to go

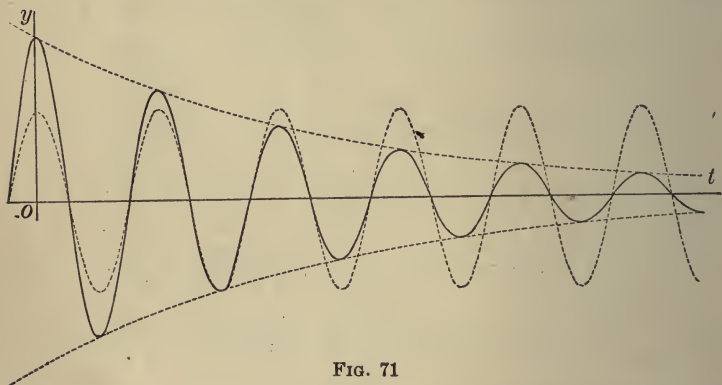

FIG. 71

through this point periodically, but with reversed phase, *i.e.* in opposite directions at intervals of $\pi / \sqrt{n^2 - \frac{1}{4}\kappa^2}$ seconds; with the same phase, at intervals of

$$T = \frac{2\pi}{\sqrt{n^2 - \frac{1}{4}\kappa^2}}$$

seconds. This latter quantity is called the *period* of the oscillation. Since

$$\frac{2\pi}{\sqrt{n^2 - \frac{1}{4}\kappa^2}} = \frac{2\pi}{n} + \frac{\pi\kappa^2}{4n^3} + \left(\begin{array}{l} \text{terms of still} \\ \text{higher order in } \kappa^2 \end{array} \right),$$

as will be shown in the chapter on Taylor's Theorem, it is seen that, when κ/n is small, the period differs but slightly from the value

$$T = \frac{2\pi}{n}$$

which it has for simple harmonic motion, $\kappa = 0$. The effect of the damping is in all cases to lengthen the period.

The amplitude, on the other hand, steadily falls off toward 0 as its limit when $t = \infty$, and thus the particle practically comes to rest after a longer or shorter time, according as κ/n is small or comparatively large. But so long as the oscillation is perceptible, the period is the same.

The Case $n^2 - \frac{1}{4}\kappa^2 = 0$. Here the quadratic (23) has equal roots, and thus the two solutions

$$e^{-m_1 t}, \quad e^{-m_2 t},$$

become coincident. $m_1 = m_2 = \frac{1}{2}\kappa$. And similarly,

$$e^{-\frac{\kappa}{2}t} \cos \sqrt{n^2 - \frac{1}{4}\kappa^2} t \quad \text{reduces to} \quad e^{-\frac{\kappa}{2}t}$$

while $e^{-\frac{\kappa}{2}t} \sin \sqrt{n^2 - \frac{1}{4}\kappa^2} t$

vanishes identically. Thus we fail to get a solution with two arbitrary constants entering in such a way that we can impose two independent conditions on the solution. It is found that in this case the general solution takes the form

$$x = (D + Et) e^{-\frac{\kappa}{2}t}.$$

Determining the constants D and E as in the cases discussed above, we obtain:

$$(33) \quad x = h \left(1 + \frac{\kappa}{2}t \right) e^{-\frac{\kappa}{2}t},$$

$$(34) \quad \frac{dx}{dt} = -\frac{\kappa^2}{4} h t e^{-\frac{\kappa}{2}t}.$$

The character of the motion is the same as in the case

$\frac{1}{4}\kappa^2 - n^2 > 0$. It can, however, also be regarded as a limiting case under $n^2 - \frac{1}{4}\kappa^2 > 0$, the very first point of intersection of the curve with the axis of abscissas having receded to infinity.

9. Motion of a Projectile. *Problem.* To find the path of a projectile acted on only by the force of gravity.

The degree of accuracy of the approximation to the true motion obtained in the following solution depends on the projectile and on the velocity with which it moves. For a cannon ball it is crude, whereas for the 16 lb. shot used in putting the shot it is decidedly good.

Hitherto we have known the path of the body; here we do not. We may state Newton's Second Law of Motion for a plane path as follows:*

$$\left\{ \begin{array}{l} m \frac{d^2x}{dt^2} = X, \\ m \frac{d^2y}{dt^2} = Y, \end{array} \right.$$

where X, Y are the components of the resultant force along the axes.

In the present case $X=0, Y=-mg$, and we have

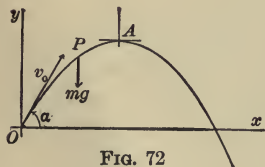

FIG. 72

$$\left\{ \begin{array}{l} m \frac{d^2x}{dt^2} = 0, \\ m \frac{d^2y}{dt^2} = -mg. \end{array} \right.$$

If we suppose the body projected from O with velocity v_0 at an angle α with the horizontal, the integration of these equations gives:

$$\frac{dx}{dt} = C = v_0 \cos \alpha, \quad x = v_0 t \cos \alpha;$$

* The form of Newton's Second Law that covers all cases, both in the plane and in space, be the motion constrained or free, is that the product of the mass by the vector acceleration is equal to the vector force.

$$\frac{dy}{dt} = v_0 \sin \alpha - gt, \quad y = v_0 t \sin \alpha - \frac{1}{2} g t^2.$$

Eliminating t we get :

$$(35) \quad y = x \tan \alpha - \frac{g x^2}{2 v_0^2 \cos^2 \alpha}.$$

The curve has a maximum at the point A :

$$x_1 = \frac{v_0^2 \sin \alpha \cos \alpha}{g}, \quad y_1 = \frac{v_0^2 \sin^2 \alpha}{2g}.$$

Transforming to a set of parallel axes through A :

$$x = x' + x_1, \quad y = y' + y_1,$$

we find:
$$y' = -\frac{g x'^2}{2 v_0^2 \cos^2 \alpha}.$$

This curve is a parabola with its vertex at A . The height of its directrix above A is $v_0^2 \cos^2 \alpha / 2g$, and hence the height of the directrix of (35) above O is

$$\frac{v_0^2 \sin^2 \alpha}{2g} + \frac{v_0^2 \cos^2 \alpha}{2g} = \frac{v_0^2}{2g}.$$

This result is independent of the angle of elevation α , and so it appears that all the paths traced out by projectiles leaving O with the same velocity have their directrices at the same level, the distance of this level above O being the height to which the projectile would rise if shot perpendicularly upward.

EXERCISES

1. Show that the range on the horizontal is

$$R = \frac{v_0^2}{g} \sin 2\alpha,$$

and that the maximum range \bar{R} is attained when $\alpha = 45^\circ$:

$$\bar{R} = \frac{v_0^2}{g}.$$

The height of the directrix above O is half this latter range.

2. A projectile is launched with a velocity of v_0 ft. a sec. and is to hit a mark at the same level and within range. Show that there are two possible angles of elevation and that one is as much greater than 45° as the other is less.

3. Find the range on a plane inclined at an angle β to the horizon and show that the maximum range is

$$R_\beta = \frac{v_0^2}{g} \frac{1}{1 + \sin \beta}.$$

4. A small boy can throw a stone 100 ft. on the level. He is on top of a house 40 ft. high. Show that he can throw the stone 134 ft. from the house. Neglect the height of his hand above the levels in question.

5. The best collegiate record for putting the shot is 46 ft. (F. Beck, Yale, 1903); the amateur and world's record is 49 ft. 6 in. (W. W. Coe, Portland, Ore., 1905).

If a man puts the shot 46 ft. and the shot leaves his hand at a height of 6 ft. 3 in. above the ground, find the velocity with which he launches it, assuming that the angle of elevation α is the most advantageous one. *Ans.* $v_0 = 35.87$.

6. How much better record can the man of the preceding question make than a shorter man of equal strength and skill, the shot leaving the latter's hand at a height of 5 ft. 3 in.?

7. Show that it is possible to hit a mark $B: (x_b, y_b)$, provided

$$y_b + \sqrt{x_b^2 + y_b^2} \leq \frac{v_0^2}{g}.$$

8. A revolver can give a bullet a muzzle velocity of 200 ft. a sec. Is it possible to hit the vane on a church spire a quarter of a mile away, the height of the spire being 100 ft.?

EXERCISES

1. A cylindrical spar buoy (specific gravity $\frac{1}{2}$) is anchored so that it is just submerged at high water. If the cable should break at high tide, show that the spar would jump entirely out of the water.

2. A number of iron weights are attached to one end of a long round wooden spar, so that, when left to itself, the spar floats vertically in water. A ten-kilogramme weight having become accidentally detached, the spar is seen to oscillate with a period of 4 seconds. The radius of the spar is 10 centimetres. Find the sum of the weights of the spar and attached iron. Through what distance does the spar oscillate?

Ans. (a) About 125 kilogrammes; (b) 0.64 metre.

3. A chain rests partly on a smooth table, a piece of the chain hanging over the edge of the table. The chain being released, find the velocity with which it will leave the table.

4. Solve the same problem for a rough table, the chain passing over a smooth pulley at the edge of the table.

5. A particle of mass 2 lbs. lies on a rough horizontal table, and is fastened to a post by an elastic band whose unstretched length is 10 inches. The coefficient of friction is $\frac{1}{3}$, and the band is doubled in length by hanging it vertically with the weight at its lower end. If the particle be drawn out to a distance of 15 inches from the post and then projected directly away from the post with an initial velocity of 5 ft. a sec., find where it will stop for good.

6. Show that if two spheres, each one foot in diameter and of density equal to the earth's mean density (specific gravity 5.6) were placed with their surfaces $\frac{1}{4}$ of an inch apart and were acted on by no other forces than their mutual attractions, they would come together in about five minutes and a half. Given that the spheres attract as if all their mass were concentrated at their centres.

7. A particle is projected horizontally along the inner surface of a smooth vertical tube. Determine its motion.

8. A man and a parachute weigh 150 pounds. How large must the parachute be that the man may trust himself to it at any height, if 25 ft. a sec. is a safe velocity with which to reach the ground? Given that the resistance of the air is as the square of the velocity and is equal to 2 pounds per square foot of opposing surface for a velocity of 30 ft. a sec.

Ans. About 12 ft. in diameter.

9. A toboggan slide of constant slope is a quarter of a mile long and has a fall of 200 ft. Assuming that the coefficient of friction is $\frac{3}{100}$, that the resistance of the air is proportional to the square of the velocity and is equal to 2 pounds per square foot of opposing surface for a velocity of 30 ft. a sec., that a loaded toboggan weighs 300 pounds and presents a surface of 3 sq. ft. to the resistance of the air; find the velocity acquired during the descent and the time required to reach the bottom.

Find the limit of the velocity that could be acquired by a toboggan under the given conditions if the hill were of infinite length.

Ans. (a) 68 ft. a sec.; (b) 30 secs.; (c) 74 ft. a sec.

10. The ropes of an elevator break and the elevator falls without obstruction till it enters an air chamber at the bottom of the shaft. The elevator weighs 2 tons and it falls from a height of 50 ft. The cross section of the well is 6×6 ft. and its depth is 12 ft. If no air escaped from the well, how far would the elevator sink in? What would be the maximum weight of a man of 170 pounds? Given that the pressure and the volume of air when compressed without gain or loss of heat follow the law:

$$pv^{1.41} = \text{const.},$$

and that the atmospheric pressure is 14 pounds to the square inch.

CHAPTER XI

THE LAW OF THE MEAN. INDETERMINATE FORMS

1. Rolle's Theorem. A theorem which lies at the foundation of the theoretical development of the Calculus is that of Rolle, from which follows the Law of the Mean.

ROLLE'S THEOREM. *If $\phi(x)$ is a function of x , continuous throughout the interval $a \leq x \leq b$ and vanishing at its extremities :*

$$\phi(a) = 0, \quad \phi(b) = 0,$$

and if it has a derivative, $\frac{d\phi(x)}{dx} = \phi'(x)$, at every interior point of the interval, then $\phi'(x)$ must vanish for at least one point within the interval :

$$\phi'(X) = 0, \quad a < X < b.$$

For, the function must be either positive or negative in some parts of the interval if we exclude the special case that $\phi(x)$ is always $= 0$, for which case the theorem is obviously true. Suppose, then, that $\phi(x)$ is positive in a part of the interval. Then $\phi(x)$ will have a maximum at some point $x = X$ within the interval, and at this point the derivative, $\phi'(x) = \tan \tau$, will vanish, cf. Chap. III, § 7:

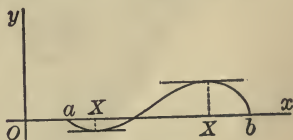

FIG. 73

$$\phi'(X) = 0, \quad a < X < b.$$

Similarly, if $\phi(x)$ is negative, it will have a minimum, and thus the theorem is proven.

2. The Law of the Mean. Let the function $f(x)$ be continuous throughout the interval $a \leq x \leq b$ and let it have a derivative, $df(x)/dx = f'(x)$, at every interior point of the interval. Draw the graph and let LM be the secant connecting its extremities. Then there will be at least one point X within the interval at which the tangent is parallel to the secant LM .

For, consider the distance from a point P of the curve to the secant, measured along an ordinate, PQ . This distance (taken algebraically) will have a maximum or a minimum value, and at such a point the tangent is evidently parallel to the secant. Now the slope of the secant is

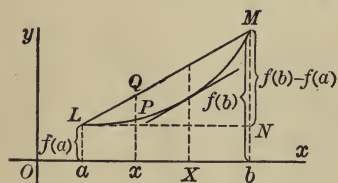

FIG. 74

$$\tan \angle NLM = \frac{f(b) - f(a)}{b - a},$$

and the slope of the curve at $x = X$ is $f'(X)$. Hence

$$\frac{f(b) - f(a)}{b - a} = f'(X),$$

$$(A) \quad f(b) - f(a) = (b - a) f'(X), \quad a < X < b.$$

This is the Law of the Mean. Another form in which it is often useful to write the theorem is obtained by setting

$$b - a = h, \quad b = a + h.$$

Then X can be written as $a + \theta h$, where θ is a proper fraction, or at least a positive quantity less than 1,* and we have:

$$(A') \quad f(a + h) - f(a) = h f'(a + \theta h), \quad 0 < \theta < 1.$$

In (A), a and b can be interchanged and in (A') h can be negative.

An analytical proof of the Law of the Mean is as follows. Form the function

$$\phi(x) = \frac{f(b) - f(a)}{b - a} (x - a) - [f(x) - f(a)].$$

* We may think of the second term, θh , as representing that portion of the interval $b - a = h$ which must be added to the segment a to take us to X .

This function satisfies all the conditions of Rolle's Theorem and hence its derivative,

$$\phi'(x) = \frac{f(b) - f(a)}{b - a} - f'(x),$$

must vanish for a value $x = X$ between a and b :

$$\frac{f(b) - f(a)}{b - a} - f'(X) = 0, \quad a < X < b.$$

Thus the theorem is proven.

This proof merely puts into analytic form the geometric proof first given, for the function $\phi(x)$ here employed is precisely the distance PQ .

3. Application. As a first application of the Law of the Mean we will give the proof of Theorem A in Chap. VI, § 2. In that theorem $\Phi'(x) = 0$ by hypothesis for all values of x , or at least for all in a certain interval. If, then, a and $b = x_1$ are two points of this interval, we have from the Law of the Mean (A):

$$\Phi(x_1) - \Phi(a) = 0,$$

i.e. $\Phi(x_1) = \Phi(a)$ for all points x_1 in question. Hence $\Phi(x)$ is a constant.

Exercise. Show that, if $f(x)$ satisfies the conditions of § 2 and if furthermore $f'(x) \geq 0$ at all points within the interval, then

$$f(x) \geq f(a).$$

4. Indeterminate Forms. The Limit $\frac{0}{0}$. If both the numerator and the denominator of a fraction

$$(1) \quad \frac{f(x)}{F(x)}$$

vanish for a particular value of x , $x = a$:

$$f(a) = 0, \quad F(a) = 0,$$

the fraction takes on the form $\frac{0}{0}$ and thus ceases to have any meaning. The fraction will, however, in general approach a limit when x approaches a , and we proceed to determine this limit.

Sometimes this can be done by a simple transformation. Thus if

$$\frac{f(x)}{F(x)} = \frac{x-a}{x^2-a^2},$$

we need only divide numerator and denominator by $x-a$ and we have:

$$\lim_{x \neq a} \frac{x-a}{x^2-a^2} = \lim_{x \neq a} \frac{1}{x+a} = \frac{1}{2a}.$$

Again, if
and $a=0$, we have

$$\frac{f(x)}{F(x)} = \frac{\tan x}{x}$$

$$\lim_{x \neq 0} \frac{\tan x}{x} = \lim_{x \neq 0} \frac{1}{\cos x} \cdot \frac{\sin x}{x} = 1.$$

When, however,⁽¹⁾ such simple devices as the foregoing are not available, we can apply the Law of the Mean. Let $b=x$ be any point near a . Then, remembering that $f(a)=0$ and $F(a)=0$, we have:

$$f(x) = (x-a)f'(X), \quad F(x) = (x-a)F'(X'),$$

where X and X' both lie between a and x , and hence

$$\frac{f(x)}{F(x)} = \frac{f'(X)}{F'(X')}.$$

When x approaches a , X and X' both approach a , too, and so, if $f'(x)$ and $F'(x)$ are continuous, as is usually the case in practice,

$$\lim_{x \neq a} f'(X) = f'(a), \quad \lim_{x \neq a} F'(X') = F'(a).$$

If, then, $F'(a) \neq 0$, we have:

$$(2) \quad \lim_{x \neq a} \frac{f(x)}{F(x)} = \frac{f'(a)}{F'(a)}.$$

The limit of such a fraction as the one above considered is referred to for brevity as *the limit* $\frac{0}{0}$.*

Example. To find $\lim_{x \rightarrow 1} \frac{\log x}{1-x}$.

$$\begin{aligned} \text{Here } f(x) &= \log x, & f'(x) &= \frac{1}{x}, & f'(1) &= 1; \\ F(x) &= 1-x, & F'(x) &= -1, & F'(1) &= -1; \\ \therefore \lim_{x \rightarrow 1} \frac{\log x}{1-x} &= -1. \end{aligned}$$

EXERCISES

Obtain the following limits without differentiating.

$$1. \lim_{x \rightarrow a} \frac{x-a}{x^3-a^3} = \frac{1}{3a^2}.$$

$$7. \lim_{x \rightarrow 0} \frac{\tan x}{\sin x} = 1.$$

$$2. \lim_{x \rightarrow 1} \frac{x-1}{x^n-1} = \frac{1}{n}.$$

$$8. \lim_{x \rightarrow 0} \frac{\sin 2x}{x} = 2.$$

$$3. \lim_{x \rightarrow a} \frac{x^2-a^2}{x^3-a^3} = \frac{2}{3a}.$$

$$9. \lim_{x \rightarrow \frac{\pi}{2}} \frac{\cos x}{\cot x} = 1.$$

$$4. \lim_{x \rightarrow 1} \frac{x^2+x-2}{x^2-1} = \frac{3}{2}.$$

$$10. \lim_{x \rightarrow 0} \frac{\tan ax}{x} = a.$$

$$5. \lim_{x \rightarrow -2} \frac{x^3+8}{x^5+32} = \frac{3}{20}.$$

$$11. \lim_{x \rightarrow 0} \frac{\tan x - \sin x}{1 - \cos x} = 0.$$

$$6. \lim_{x \rightarrow 0} \frac{\sqrt{a+x} - \sqrt{a}}{x} = \frac{1}{2\sqrt{a}}.$$

$$12. \lim_{x \rightarrow 0} \frac{1 - \cos x}{\sin^2 x} = \frac{1}{2}.$$

13. Obtain the limits in Exs. 2, 4, 7, 9 by differentiation.

* This limit is also called the "true value" of the "indeterminate form" $f(x)/F(x)$ for $x = a$. Both terms are based on a false conception. In the early days of the Calculus mathematicians thought of the fraction as really having a value when $x = a$, only the value cannot be computed because the form of the fraction eludes us. This is wrong. Division by 0 is not a process which we define in Algebra. It is convenient, however, to retain the term *indeterminate form* as applying to such expressions as the above and others considered in this chapter, which for a certain value of the independent variable cease to have a meaning, but which approach a limit when the independent variable converges toward the exceptional value.

Obtain the following limits by differentiation.

$$14. \lim_{x \neq 0} \frac{e^x - 1}{x} = 1.$$

$$20. \lim_{x \neq \frac{\pi}{4}} \frac{\tan x - 1}{x - \frac{\pi}{4}} = 2.$$

$$15. \lim_{x \neq 0} \frac{a^x - 1}{x} = \log a.$$

$$21. \lim_{x \neq \frac{1}{2}} \frac{1 - \sqrt{2} \sin \pi x}{1 - \sqrt{2} \cos \pi x} = -1.$$

$$16. \lim_{x \neq 0} \frac{a^x - b^x}{x} = \log \frac{a}{b}.$$

$$22. \lim_{x \neq 1} \frac{x^{\frac{3}{2}} - 1 + (x-1)^{\frac{3}{2}}}{(x^2 - 1)^{\frac{3}{2}} - x + 1} = -\frac{3}{2}.$$

$$17. \lim_{x \neq 1} \frac{\log_{10} x}{x - 1} = .4343.$$

$$23. \lim_{x \neq a} \frac{\sqrt{x} - \sqrt{a}}{\sqrt[3]{x} - \sqrt[3]{a}} = \frac{3}{2} a^{\frac{1}{6}}.$$

$$18. \lim_{x \neq 0} \frac{e^x - e^{-x}}{\sin x} = 2.$$

$$24. \lim_{x \neq \frac{1}{2}} \frac{\cos \pi x}{2x - 1} = -\frac{\pi}{2}.$$

$$19. \lim_{x \neq -1} \frac{\sin \pi x}{1 + x} = -\pi.$$

$$25. \lim_{x \neq 3} \frac{x^4 + 3x^3 - 7x^2 - 27x - 18}{x^4 - 3x^3 - 7x^2 + 27x - 18}. \quad \text{Check your answer.}$$

5. A More General Form of the Law of the Mean. The method of evaluating $\lim f(x)/F(x)$ set forth in § 4 is inapplicable when $f'(a)$ and $F'(a)$ both vanish, for then $f'(a)/F'(a)$ ceases to have a meaning. Moreover, since we do not know how X and X' vary, — it is not at present clear that they can be taken equal to each other, — we cannot see what limit $f'(X)/F'(X')$ approaches. We can deal with this and other cases that arise by the aid of the following

GENERALIZED LAW OF THE MEAN. *If $f(x)$ and $F(x)$ are continuous throughout the interval $a \leq x \leq b$ and each has a derivative at all interior points of the interval, and if, moreover, the derivative $F'(x)$ does not vanish within the interval; then, for some value $x = X$ within this interval,*

$$(B) \quad \frac{f(b) - f(a)}{F(b) - F(a)} = \frac{f'(X)}{F'(X)}, \quad a < X < b.$$

The proof is as follows. Form the function :

$$\phi(x) = \frac{f(b)-f(a)}{F(b)-F(a)} [F(x) - F(a)] - [f(x) - f(a)].$$

This function satisfies all the conditions of Rolle's Theorem, and hence its derivative,

$$\phi'(x) = \frac{f(b)-f(a)}{F(b)-F(a)} F'(x) - f'(x),$$

must vanish for a value of x within the interval. Hence

$$\frac{f(b)-f(a)}{F(b)-F(a)} F'(X) - f'(X) = 0, \quad a < X < b.$$

By hypothesis, $F'(x)$ is never 0 in the interval. Consequently we are justified in dividing through by it, and thus we obtain Formula (B), q.e.d.

6. The Limit $\frac{0}{0}$, Concluded. We can now state a more general rule for determining the limit considered in § 4. Suppose $f(a) = 0$ and $F(a) = 0$. Let x be a point near a and set $b = x$ in (B). Then

$$\frac{f(x)}{F(x)} = \frac{f'(X)}{F'(X)},$$

where now we have the same X in both numerator and denominator, and X lies between x and a . When x approaches a , X will also approach a . Hence, if $f'(x)/F'(x)$ approaches a limit, $f'(X)/F'(X)$ will approach the same limit, and so will its equal, $f(x)/F(x)$. Thus we have :

$$(I) \quad \lim_{x \rightarrow a} \frac{f(x)}{F(x)} = \lim_{x \rightarrow a} \frac{f'(x)}{F'(x)}.$$

If, then, it turns out on differentiating that $f'(a) = 0$ and $F'(a) = 0$, we can differentiate again, and so on.

Example. To find $\lim_{x \rightarrow 0} \frac{e^x - 1 - \sin x}{1 - \cos x}$.

Here
$$\frac{f'(x)}{F'(x)} = \frac{e^x - \cos x}{\sin x},$$

and the new ratio is still indeterminate when $x = 0$. Differentiating again we have

$$\lim_{x \neq 0} \frac{e^x + \sin x}{\cos x} = 1.$$

Hence the value of the original limit is 1.

7. The Limit $\frac{\infty}{\infty}$. The rule for finding the limit of the ratio (1) when both the numerator and the denominator become infinite for $x = a$:

$$f(a) = \infty, \quad F(a) = \infty,$$

is the same as when both the numerator and the denominator vanish, namely: *Differentiate the numerator for a new numerator, the denominator for a new denominator, and take the limit of the new ratio:*

$$(II) \quad \lim_{x \neq a} \frac{f(x)}{F(x)} = \lim_{x \neq a} \frac{f'(x)}{F'(x)}.$$

To prove this theorem let us first take the case that $a = \infty$, i.e. that the independent variable x increases without limit. In the Generalized Law of the Mean (B), replace a by x' and b by x :

$$(3) \quad \frac{f(x) - f(x')}{F(x) - F(x')} = \frac{f'(X)}{F'(X)}, \quad x' < X < x,$$

and write the left-hand side in the form:

$$(4) \quad \frac{f(x)}{F(x)} \cdot \frac{1 - f(x')/f(x)}{1 - F(x')/F(x)}.$$

It is easily seen that the second factor, which we will denote by λ :

$$\frac{1 - f(x')/f(x)}{1 - F(x')/F(x)} = \lambda,$$

can be made to approach 1 as its limit. For, as x and x' increase without limit, both $f(x)$ and $f(x')$, and also $F(x)$ and $F(x')$, become infinite. Now x and x' are independent of each

other. We may, therefore, choose x' so that, while still becoming infinite as x becomes infinite, it increases so much more slowly than x that

$$\lim \frac{f(x')}{f(x)} = 0, \quad \lim \frac{F'(x')}{F'(x)} = 0.$$

On the other hand, X always lying between x' and x and therefore becoming infinite with them, it is clear that, if $f'(x)/F'(x)$ approaches a limit when $x = \infty$, then $f'(X)/F'(X)$ will approach the same limit. Hence, writing (3) by the aid of (4) in the form:

$$\frac{f(x)}{F(x)} = \frac{1}{\lambda} \frac{f'(X)}{F'(X)},$$

we see that the right-hand side approaches as its limit the same limit that $f'(x)/F'(x)$ approaches. The left-hand side must, therefore, also approach this limit, and the theorem is proved, when $a = \infty$.

If x approaches a limit a , we need only to introduce a new variable:

$$y = \frac{1}{x-a}, \quad x = a + \frac{1}{y}.$$

$$\text{Setting } f(x) = f\left(a + \frac{1}{y}\right) = \phi(y), \quad F(x) = F\left(a + \frac{1}{y}\right) = \Phi(y),$$

we have from the foregoing result:

$$\lim_{y=\infty} \frac{\phi(y)}{\Phi(y)} = \lim_{y=\infty} \frac{\phi'(y)}{\Phi'(y)}.$$

$$\text{But } \phi'(y) = f'(x) \frac{-1}{y^2}, \quad \Phi'(y) = F'(x) \frac{-1}{y^2},$$

$$\therefore \frac{\phi'(y)}{\Phi'(y)} = \frac{f'(x)}{F'(x)}.$$

If, then, $f'(x)/F'(x)$ approaches a limit when x approaches a , $\phi'(y)/\Phi'(y)$ will approach the same limit when $y = \infty$.

Hence $\phi(y)/\Phi(y)$ will approach this limit, too. But $\phi(y)/\Phi(y) = f(x)/F(x)$. This completes the proof.*

Example. To find $\lim_{x \rightarrow \infty} \frac{x}{e^x}$.

We have:
$$\lim_{x \rightarrow \infty} \frac{x}{e^x} = \lim_{x \rightarrow \infty} \frac{1}{e^x} = 0.$$

8. The Limit $0 \cdot \infty$. If we have the product of two functions:

$$f(x) \cdot \phi(x),$$

one of which approaches 0 as x approaches a , while the other becomes infinite, we can determine the limit of this product by throwing the latter into one of the forms:

$$\frac{f(x)}{1} \quad \text{or} \quad \frac{\phi(x)}{f(x)},$$

i.e. the form $0/0$ or ∞/∞ , and then applying the foregoing methods.

Example. To find $\lim_{x \rightarrow 0} x \log x$.

Here it is better to choose the form

$$x \log x = \frac{\log x}{1/x},$$

for then the logarithm will disappear on differentiation:

$$\lim_{x \rightarrow 0} \frac{\log x}{x^{-1}} = \lim_{x \rightarrow 0} \frac{1/x}{-1/x^2} = \lim_{x \rightarrow 0} (-x) = 0.$$

* The theorem contained in (2) goes back to l'Hospital, 1696. The theorem of this paragraph is due to Cauchy, 1823 and 1829, who proved it, however, only on the assumption that $f(x)/F(x)$ approaches a limit. Stolz extended it in 1879 as in the text, showing that, if $f'(x)/F'(x)$ approaches a limit, then $f(x)/F(x)$ will also approach a limit, and this will be the same limit.

EXERCISES

Determine the following limits.

1. $\lim_{x \rightarrow \infty} \frac{x^2}{e^x}$. *Ans.* 0. 6. $\lim_{x \neq 0} x \log \sin x$. *Ans.* 0.
 2. $\lim_{x \rightarrow \infty} \frac{x^n}{e^x}$. *Ans.* 0. 7. $\lim_{x \neq 0} \frac{\cot x}{\cot 3x}$. *Ans.* 3.
 3. $\lim_{x \neq 0} x \cot \pi x$. *Ans.* $\frac{1}{\pi}$. 8. $\lim_{x \neq 0} x^\alpha \log x$, $\alpha > 0$. *Ans.* 0.
 4. $\lim_{x \rightarrow \infty} \frac{\log x}{x}$. *Ans.* 0. 9. $\lim_{x \rightarrow \infty} \frac{e^x}{\log x}$. *Ans.* ∞ .
 5. $\lim_{x \rightarrow \infty} \frac{\log x}{x^n}$, $n > 0$. *Ans.* 0. 10. $\lim_{x \neq 0} \frac{\log \sin 2x}{\log \sin x}$. *Ans.* 1.

9. The Limits 0^0 , 1^∞ , ∞^0 , and $\infty - \infty$. The expression

$$(5) \quad f(x)^{\phi(x)}$$

ceases to have a meaning when $f(x)$ and $\phi(x)$ take on certain pairs of values. If we write (cf. Formula (5) on p. 77)

$$f(x) = e^{\log f(x)}, \quad f(x)^{\phi(x)} = e^{\phi(x) \log f(x)},$$

we see that the expression (5) becomes indeterminate when the exponent of e takes on the form $0 \cdot \infty$. We are thus led to consider new limits of the types:

- (a) $f(a) = 0, \quad \phi(a) = 0; \quad 0^0$.
 (b) $f(a) = 1, \quad \phi(a) = \infty; \quad 1^\infty$.
 (c) $f(a) = \infty, \quad \phi(a) = 0; \quad \infty^0$.

The limiting value of the exponent of a can be obtained by the method of § 8, and hence the limit of (5) determined.

Example. To find $\lim_{x \neq 0} (\cos x)^{\frac{1}{x^3}}$.

$$(\cos x)^{\frac{1}{x^3}} = e^{\frac{\log \cos x}{x^3}},$$

$$\lim_{x \neq 0} \frac{\log \cos x}{x^3} = \lim_{x \neq 0} \frac{-\sin x}{3x^2 \cos x}.$$

This last limit can be obtained immediately by a simple transformation:

$$\frac{-\sin x}{3x^2 \cos x} = -\frac{1}{3x \cos x} \cdot \frac{\sin x}{x}.$$

Hence we see that the exponent of e becomes negatively infinite if x approaches 0 from the positive side, and so

$$\lim_{x \rightarrow 0^+} (\cos x)^{\frac{1}{x^3}} = 0.$$

If, however, x approaches 0 from the negative side, the exponent of e becomes positively infinite, and

$$\lim_{x \rightarrow 0^-} (\cos x)^{\frac{1}{x^3}} = \infty.$$

A convenient notation for distinguishing between these two cases is the following:

$$\lim_{x \rightarrow 0^+} (\cos x)^{\frac{1}{x^3}} = 0, \quad \lim_{x \rightarrow 0^-} (\cos x)^{\frac{1}{x^3}} = \infty.$$

The Limit $\infty - \infty$. If we have the difference of two functions, each of which is becoming infinite, as

$$\log(x+1) - \log x$$

when $x = \infty$, it is sometimes possible to evaluate the limit by a simple transformation. For example:

$$\log(x+1) - \log x = \log\left(1 + \frac{1}{x}\right), \quad \lim_{x \rightarrow \infty} \log\left(1 + \frac{1}{x}\right) = 0.$$

More often, however, the simplest method is that of infinite series, cf. Chap. XIII.

EXERCISES

Determine the following limits.

1. $\lim_{x \rightarrow 0} x^x$. Ans. 1.
3. $\lim_{x \rightarrow 1} x^{\frac{1}{1-x}}$. Ans. $\frac{1}{e}$.
2. $\lim_{x \rightarrow 0} (1 + \sin x)^{\cot x}$. Ans. e .
4. $\lim_{x \rightarrow \infty} (\sqrt{1+x^2} - x)$. Ans. 0.

5. $\lim_{x \rightarrow 0} (\cot x)^x$. *Ans.* 1. 9. $\lim_{x \rightarrow \frac{\pi}{2}} \left(x \tan x - \frac{\pi}{2} \sec x \right)$.
6. $\lim_{x \rightarrow \infty} \left(\frac{a}{x} + 1 \right)^x$. *Ans.* e^a . *Ans.* -1.
7. $\lim_{x \rightarrow 0} (\cos x)^{\frac{1}{x^2}}$. *Ans.* $\frac{1}{\sqrt{e}}$. 10. $\lim_{x \rightarrow 1} \left(\frac{1}{\log x} - \frac{x}{\log x} \right)$.
8. $\lim_{x \rightarrow a} \left(2 - \frac{x}{a} \right)^{\tan \frac{\pi x}{2a}}$. *Ans.* $e^{2/\pi}$. *Ans.* -1.

EXERCISES

Determine the following limits.

1. $\lim_{x \rightarrow \infty} \frac{2 - 3x + 4x^5}{7x + x^3 + 7x^5}$. 11. $\lim_{x \rightarrow a} \frac{\sqrt[7]{x} - \sqrt[7]{a}}{\sqrt[3]{x} - \sqrt[3]{a}}$.
2. $\lim_{x \rightarrow \infty} \frac{3 + x}{4 - 9x + x^2}$. 12. $\lim_{x \rightarrow a} \frac{\sqrt[4]{x - a}}{\sqrt{x} - \sqrt[4]{a}}$.
3. $\lim_{x \rightarrow \infty} \frac{\sqrt{9 + 2x^7}}{x^2}$. 13. $\lim_{x \rightarrow 0} \sin x (\log x)^2$.
4. $\lim_{x \rightarrow \infty} \frac{\sqrt{a + bx + cx^2}}{\sqrt[3]{a + \beta x + x^3}}$. 14. $\lim_{x \rightarrow a} \frac{e^{mx} - e^{ma}}{(x - a)^r}$.
5. $\lim_{x \rightarrow \infty} \left[\frac{x^2}{a - x} + \frac{x^2}{a + x} \right]$. 15. $\lim_{x \rightarrow 0} \csc^2 \beta x \log \cos \alpha x$.
6. $\lim_{x \rightarrow a} \sqrt{a^2 - x^2} \cot \frac{\pi}{2} \sqrt{\frac{a - x}{a + x}}$. 16. $\lim_{n \rightarrow -1} \frac{x^{n+1} - 1}{n + 1}$.
7. $\lim_{x \rightarrow 1} \frac{\cos^{-1} x}{\sqrt{1 - x^2}}$. 17. $\lim_{x \rightarrow 1} (1 - x) \tan \frac{\pi x}{2}$.
8. $\lim_{x \rightarrow \frac{\pi}{2}} \frac{x \sin x - \frac{\pi}{2}}{\cos x}$. 18. $\lim_{x \rightarrow \infty} a^{-x} \log x$.
9. $\lim_{n \rightarrow \infty} n \sin \frac{x}{n}$. 19. $\lim_{x \rightarrow \infty} \frac{x^2 - x}{1 - x + \log x}$.
10. $\lim_{x \rightarrow \infty} \frac{e^{x^2}}{x^3}$. 20. $\lim_{x \rightarrow \infty} \frac{\sqrt[3]{1 + x^6}}{1 - x + 2\sqrt{1 + x^2} + x^4}$.

$$21. \lim_{x \neq 1} \left[\frac{x}{\sqrt[3]{1-x}} - \frac{x^2}{\sqrt[5]{1-x}} \right].$$

$$23. \lim_{x \neq 0} x^\alpha (\log x)^\beta, \alpha > 0, \beta > 0.$$

$$22. \lim_{x \neq 0} \csc x \sin (\tan x).$$

$$24. \lim_{x = \infty} \frac{(\log x)^m}{x^n}, m > 0, n > 0.$$

$$25. \lim_{x = \infty} G(x) e^{-x}, \text{ where } G(x) \text{ is a polynomial.}$$

26. Show that

$$\lim_{x \neq 0} \frac{e^{-\frac{1}{x^2}}}{x^n} = 0,$$

n being any constant whatever.

CHAPTER XII

CONVERGENCE OF INFINITE SERIES *

1. **The Geometric Series.** We have met in Algebra the Geometric Progression:

$$a + ar + ar^2 + \dots,$$

the sum of the first n terms of which is given by the formula:

$$s_n = \frac{a - ar^n}{1 - r}.$$

Suppose, for example, that $a = 1$, $r = \frac{1}{2}$. Then

$$s_1 = 1 = 1$$

$$s_2 = 1 + \frac{1}{2} = 1\frac{1}{2}$$

$$s_3 = 1 + \frac{1}{2} + \frac{1}{4} = 1\frac{3}{4}$$

$$s_4 = 1 + \frac{1}{2} + \frac{1}{4} + \frac{1}{8} = 1\frac{7}{8}.$$

etc.

If we plot on a line the points which represent s_1, s_2, s_3, \dots , it is easy to see how to obtain s_n from its predecessor, s_{n-1} ,



FIG. 75

namely: s_n lies half way between s_{n-1} and the point 2. Hence it appears that, when n grows larger and larger without limit, s_n approaches 2 as its limit.

* This chapter is in substance a reproduction of Chapter I of the author's *Introduction to Infinite Series*, published by Harvard University.

In general, if r is numerically less than 1,

$$|r| < 1, \quad \text{i.e.} \quad -1 < r < 1,$$

r^n will approach 0 as its limit when $n = \infty$, and we shall have:

$$\lim_{n=\infty} s_n = \frac{a}{1-r}.$$

We have here an example of an infinite series, whose value is $a/(1-r)$:

$$(1) \quad \frac{a}{1-r} = a + ar + ar^2 + \dots, \quad |r| < 1,$$

and we turn now to the general definition of such series.

2. Definition of an Infinite Series. Let u_0, u_1, u_2, \dots be any set of values, positive or negative at pleasure. Form the sum:

$$(2) \quad s_n = u_0 + u_1 + \dots + u_{n-1}.$$

When n increases without limit, s_n may approach a limit, U :

$$\lim_{n=\infty} s_n = U.$$

In this case the series which stands on the right-hand side of (2) is said to *converge* and to have the *value* U .* It is customary to express both of these facts by the equation:

$$(3) \quad U = u_0 + u_1 + \dots$$

But if s_n approaches no limit, the series is said to *diverge*.

Such a series is called an *infinite series*. An infinite series, then, is a variable consisting of the sum of n terms.† It is said to be convergent if the value of this sum, s_n , approaches a limit when $n = \infty$; otherwise to be divergent. And in the case of convergence its value is defined as $\lim_{n=\infty} s_n$. No value is assigned to a divergent series.

* U is often called the "sum" of the series. But the student must not forget that U is *not* a sum, but is the *limit* of a sum. Similarly, the expression, "the sum of an infinite number of terms" means the *limit* of the sum of n of these terms, as n increases without limit.

† Each term of the series, however, as u_0 or u_1 or u_k , is independent of the number of terms n involved in the above sum.

Examples of divergent series are:

$$1 + 2 + 3 + 4 + \dots,$$

$$1 - 1 + 1 - 1 + \dots.$$

A notation commonly employed for the series (3) is

$$\sum u_n \quad \text{or, more explicitly:} \quad \sum_{n=0}^{\infty} u_n.$$

Thus the geometric series (1) would be written:

$$\sum_{n=0}^{\infty} ar^n.$$

3. Tests for Convergence. Consider the infinite series

$$(4) \quad 1 + 1 + \frac{1}{1 \cdot 2} + \frac{1}{1 \cdot 2 \cdot 3} + \dots + \frac{1}{n!} + \dots,$$

where $n!$ means $1 \cdot 2 \cdot 3 \dots n$ and is read "factorial n ." Disregarding for the moment the first term, compare the sum of the next n terms,

$$\sigma_n = 1 + \frac{1}{1 \cdot 2} + \frac{1}{1 \cdot 2 \cdot 3} + \dots + \frac{1}{1 \cdot 2 \cdot 3 \dots n},$$

with the corresponding sum of the geometric series,

$$\begin{aligned} S_n &= 1 + \frac{1}{2} + \frac{1}{2 \cdot 2} + \dots + \underbrace{\frac{1}{2 \cdot 2 \dots 2}}_{n-1 \text{ factors}} \\ &= 2 - \frac{1}{2^{n-1}} < 2. \end{aligned}$$

The terms of σ_n after the first two are less than those of S_n and hence

$$\sigma_n < S_n < 2.$$

Inserting the discarded term and denoting the sum of the first n terms of (4) by s_n we have:

$$s_{n+1} = 1 + 1 + \frac{1}{2!} + \frac{1}{3!} + \dots + \frac{1}{n!} < 3,$$

no matter how large n be taken. That is to say, s_n is a variable that always increases as n increases, but that never attains

so large a value as 3. We can make these relations clear to the eye by plotting the successive values of n as points on a line.

$$s_1 = 1 \qquad = 1$$

$$s_2 = 1 + 1 \qquad = 2$$

$$s_3 = 1 + 1 + \frac{1}{2!} \qquad = 2.5$$

$$s_4 = 1 + 1 + \frac{1}{2!} + \frac{1}{3!} = 2.667$$

$$s_5 = 2.708, \quad s_6 = 2.717, \quad s_7 = 2.718, \quad s_8 = 2.718.$$

Thus we see that, when n increases by 1, the point representing s_n always moves to the right, but never advances so far as the point 3. Hence s_n approaches a limit e which is not greater than 3, and the series is convergent. To judge from the computed values of s_n , the value of e to four significant figures is 2.718, a fact that will be established later.

The reasoning by which we have inferred the existence of a limit in the above example is of prime importance in the theory of infinite series as well as in other branches of analysis. We will formulate it as follows.

FUNDAMENTAL PRINCIPLE. *If s_n is a variable which (1) always increases (or remains unchanged) when n increases:*

$$s_{n'} \geq s_n, \qquad n' > n;$$

but which (2) never exceeds some definite fixed number, A :

$$s_n \leq A,$$

no matter what value n has, then s_n approaches a limit, U :

$$\lim_{n \rightarrow \infty} s_n = U.$$

The limit U is not greater than A : $U \leq A$.

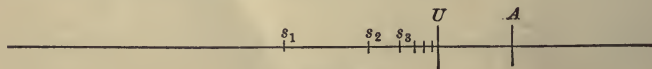

FIG. 76

EXERCISE

State the Principle for a variable which is always decreasing, but which remains greater than a certain fixed quantity, and draw the corresponding diagram.

By means of the foregoing principle we can state a simple test for the convergence of an infinite series of positive terms.

DIRECT COMPARISON TEST. *Let*

$$u_0 + u_1 + \dots$$

be a series of positive terms which is to be tested for convergence. If a second series of positive terms already known to be convergent:

$$a_0 + a_1 + \dots,$$

can be found whose terms are greater than or at most equal to the corresponding terms of the series to be tested:

$$u_n \leq a_n,$$

then the first series converges and its value does not exceed the value of the test-series.

For let

$$s_n = u_0 + u_1 + \dots + u_{n-1},$$

$$S_n = a_0 + a_1 + \dots + a_{n-1},$$

$$\lim_{n=\infty} S_n = A.$$

Then since $S_n < A$ and $s_n \leq S_n$,

it follows that $s_n < A$.

Hence s_n approaches a limit $U \leq A$, q. e. d.

It is frequently convenient in studying the convergence of a series to discard a few terms at the beginning and to consider the new series thus arising. That the convergence of the latter series is necessary and sufficient for the convergence of the former is evident, since

$$\begin{aligned} s_n &= (u_0 + u_1 + \dots + u_{m-1}) + (u_m + \dots + u_{n-1}) \\ &= \bar{u} + \bar{s}_{n-m}. \end{aligned}$$

Here \bar{u} is constant and s_n will converge toward a limit if \bar{s}_{n-m} does, and conversely.

EXERCISES

Prove the following series to be convergent.

$$1. \quad 1 + \frac{1}{2^2} + \frac{1}{3^3} + \frac{1}{4^4} + \dots$$

$$2. \quad r + r^4 + r^9 + r^{16} + \dots, \quad 0 \leq r < 1.$$

$$3. \quad \frac{1}{3!} + \frac{1}{5!} + \frac{1}{7!} + \dots$$

$$4. \quad \frac{1}{1 \cdot 2} + \frac{1}{2 \cdot 3} + \frac{1}{3 \cdot 4} + \dots$$

Suggestion: Write s_n in the form :

$$s_n = \left(1 - \frac{1}{2}\right) + \left(\frac{1}{2} - \frac{1}{3}\right) + \dots + \left(\frac{1}{n} - \frac{1}{n+1}\right) = 1 - \frac{1}{n+1}.$$

$$5. \quad \frac{1}{1 \cdot 2} + \frac{1}{3 \cdot 4} + \frac{1}{5 \cdot 6} + \dots$$

$$6. \quad \frac{1}{2^2} + \frac{1}{3^2} + \frac{1}{4^2} + \dots$$

$$7. \quad 1 + \frac{1}{2^p} + \frac{1}{3^p} + \dots, \quad p > 2.*$$

4. Divergent Series. If a series is to converge, then evidently its terms must approach 0 as their limit. For otherwise the points s_n could not cluster about a single point as their limit. Hence we get the following exceedingly simple test for divergence. It holds for series whose terms are positive and negative at pleasure.

If the terms of a series do not approach 0 as their limit, the series diverges.

* It can be shown that this series converges when $p > 1$; cf. *Infinite Series*, § 6.

This condition, however, is only sufficient, not necessary, as the following example shows:

$$1 + \frac{1}{2} + \frac{1}{3} + \frac{1}{4} + \dots$$

If we strike in anywhere in this series and add as many more terms as the number that have preceded:

$$\frac{1}{n+1} + \frac{1}{n+2} + \dots + \frac{1}{n+n},$$

we get a sum $> \frac{1}{2}$. For each term just written down is $> 1/2n$, and there are n of them. If, then, we can get a sum greater than $\frac{1}{2}$ out of the series as often as we like, we can get a sum that exceeds a billion, or any other number you choose to name, by adding a sufficient number of terms together. Hence the series diverges in spite of the fact that its terms are growing smaller and smaller. This series is known as the *harmonic series*.

A further test for divergence corresponding to the test of § 3 for convergence is as follows.

DIRECT COMPARISON TEST. *Let*

$$u_0 + u_1 + \dots$$

be a series of positive terms which is to be tested for divergence. If a second series of positive terms already known to be divergent:

$$a_0 + a_1 + \dots$$

can be found whose terms are less than or at most equal to the corresponding terms of the series to be tested:

$$u_n \geq a_n,$$

then that series diverges.

The proof is similar to that of the test of § 3 for convergence and is left to the student as an exercise.

EXERCISES

Prove the following series to be divergent.

$$1. \quad 1 + \frac{1}{\sqrt{2}} + \frac{1}{\sqrt{3}} + \frac{1}{\sqrt{4}} + \dots$$

$$2. \quad \frac{1}{2} + \frac{1}{4} + \frac{1}{6} + \frac{1}{8} + \dots$$

$$3. \quad 1 + \frac{1}{3} + \frac{1}{5} + \frac{1}{7} + \dots,$$

$$4. \quad 1 + \frac{1}{2^p} + \frac{1}{3^p} + \frac{1}{4^p} + \dots, \quad p < 1.$$

5. The Test-Ratio Test. The most useful test for the convergence or the divergence of a series is the following, which holds regardless of whether the terms are positive or negative. It makes use of the ratio of the general term to its predecessor, u_{n+1}/u_n , — the *test-ratio*, as we shall call it.

THE TEST-RATIO TEST. *Let*

$$u_0 + u_1 + \dots$$

be an infinite series and let the limit approached by its test-ratio be denoted by t :

$$\lim_{n \rightarrow \infty} \frac{u_{n+1}}{u_n} = t.$$

Then if $|t| < 1$, *the series converges;*

“ $|t| > 1$, “ “ *diverges;*

“ $|t| = 1$, *the test fails.*

We shall prove the theorem in this paragraph, so far as it relates to convergence, only for the case that the terms are all positive. Then $t \geq 0$ and $|t| = t$.

Suppose $t < 1$. Let γ be chosen between t and 1: $t < \gamma < 1$. Since the variable u_{n+1}/u_n approaches t as its limit, the points representing this variable cluster about the point t and hence

ultimately, — *i.e.* from a definite value of n on: $n \geq m$, — lie to the left of the point γ :

$$\frac{u_{n+1}}{u_n} < \gamma, \quad n \geq m.$$

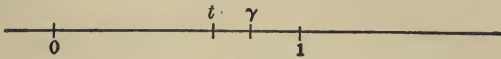

FIG. 77

Now give to n successively the values $m, m + 1$, etc.:

$$n = m, \quad \frac{u_{m+1}}{u_m} < \gamma, \quad u_{m+1} < u_m \gamma;$$

$$n = m + 1, \quad \frac{u_{m+2}}{u_{m+1}} < \gamma, \quad u_{m+2} < u_{m+1} \gamma < u_m \gamma^2;$$

$$n = m + 2, \quad \frac{u_{m+3}}{u_{m+2}} < \gamma, \quad u_{m+3} < u_{m+2} \gamma < u_m \gamma^3;$$

.

Hence we see that the terms of the given series, from the term u_m on, do not exceed the terms of the convergent geometric series

$$u_m + u_m \gamma + u_m \gamma^2 + \dots,$$

and therefore the given series converges.*

Secondly, let $|t| > 1$, the terms now being either positive or negative. Then, when $n \geq m$,

$$\frac{|u_{n+1}|}{|u_n|} > 1 \quad \text{or} \quad |u_{n+1}| > |u_n|,$$

i.e. all later terms are numerically greater than the constant u_m , and so they do not approach 0 as their limit. Hence the series diverges.

* The student should notice that it is not enough, in order to insure convergence, that the test-ratio remain less than unity when $n \geq m$. Thus for the harmonic series $u_{n+1}/u_n = n/(n + 1) < 1$ for all values of n , and yet the series diverges. But the *limit* of the test-ratio is not less than 1. What is needed for the proof is that the test-ratio should ultimately become and remain less than some *constant* quantity, γ , itself *less than 1*.

Lastly, if $|t| = 1$, we can draw no inference about the convergence of the series, for both convergent and divergent series may have the limit of their test-ratio equal to unity. Thus for the harmonic series, known to be divergent:

$$\frac{u_{n+1}}{u_n} = \frac{n}{n+1} = \frac{1}{1 + \frac{1}{n}}, \quad \lim_{n=\infty} \frac{u_{n+1}}{u_n} = 1;$$

while for the convergent series of § 3, Ex. 6:

$$\frac{u_{n+1}}{u_n} = \left(\frac{n}{n+1}\right)^2, \quad \text{and} \quad \lim_{n=\infty} \frac{u_{n+1}}{u_n} = 1.$$

EXERCISES

Test the following series for convergence or divergence.

1. $\frac{1}{2} + \frac{2}{2^2} + \frac{3}{2^3} + \frac{4}{2^4} + \dots$ *Ans.* Convergent.

2. $\frac{1 \cdot 2}{100^2} + \frac{1 \cdot 2 \cdot 3}{100^3} + \frac{1 \cdot 2 \cdot 3 \cdot 4}{100^4} + \dots$ *Ans.* Divergent.

3. $\frac{1}{3} + \frac{1 \cdot 2}{3 \cdot 5} + \frac{1 \cdot 2 \cdot 3}{3 \cdot 5 \cdot 7} + \dots$ 5. $\frac{2^{100}}{2} + \frac{3^{100}}{2^2} + \frac{4^{100}}{2^3} + \dots$

4. $\frac{3^2}{2^5} + \frac{3^3}{2^{10}} + \frac{3^4}{2^{15}} + \dots$ 6. $\frac{3}{5^3} + \frac{3^2}{10^3} + \frac{3^3}{15^3} + \dots$

For what values of x are the following series convergent, for what values divergent?

7. $1 + x^2 + x^4 + \dots$ 9. $1 + \frac{x^2}{2} + \frac{x^4}{4} + \frac{x^6}{6} + \dots$

8. $x^3 + x^5 + x^7 + \dots$ 10. $1 + x^2 + \frac{x^4}{2!} + \frac{x^6}{3!} + \dots$

6. Alternating Series. THEOREM. *Let the terms of an infinite series be alternately positive and negative:*

$$u_0 - u_1 + u_2 - \dots$$

If (1) each u is less than or equal to its predecessor: $u_{n+1} \leq u_n$,

and (2) $\lim_{n \rightarrow \infty} u_n = 0$,

the series converges.

For example:

$$1 - \frac{1}{2} + \frac{1}{3} - \frac{1}{4} + \dots$$

Denote as usual the sum of the first n terms by s_n . Then, when n is even, $n = 2m$, we have:

$$s_{2m} = (u_0 - u_1) + (u_2 - u_3) + \dots + (u_{2m-2} - u_{2m-1}).$$

Thus s_{2m} always increases or remains unchanged when m increases.

If n is odd, $n = 2m + 1$,

$$s_{2m+1} = u_0 - (u_1 - u_2) - \dots - (u_{2m-1} - u_{2m}),$$

and we see that s_{2m+1} steadily decreases or remains unchanged when m increases.

Furthermore, s_{2m} does not exceed the fixed value s_1 . For

$$s_{2m} = s_{2m+1} - u_{2m} \leq s_{2m+1} \leq s_1.$$

Hence, by the Fundamental Principle of § 3, s_{2m} approaches a limit.

In like manner it is shown that s_{2m+1} is never less than s_2 . For

$$s_{2m+1} = s_{2m} + u_{2m} \geq s_{2m} \geq s_2.$$

Hence s_{2m+1} also approaches a limit.

Finally, these limits are equal. For, since

$$s_{2m+1} = s_{2m} + u_{2m}, \quad \lim_{m \rightarrow \infty} s_{2m+1} = \lim_{m \rightarrow \infty} s_{2m} + \lim_{m \rightarrow \infty} u_{2m},$$

and, by hypothesis, $\lim u_n = 0$. Hence s_n approaches a limit when n becomes infinite passing through both odd and even values, and the series converges, q. e. d.

It is easily seen that the error made by breaking an alternating series off at any given term does not exceed numerically the value of the last term retained.

7. Series of Positive and Negative Terms; General Case. Let

$$\sigma_m = v_0 + v_1 + \cdots + v_{m-1}$$

be the sum of the first m positive terms of the series (2),

$$-\tau_p = -w_0 - w_1 - \cdots - w_{p-1}$$

the sum of the first p negative terms. Then s_n can, by a suitable choice of m and p , be written in the form: *

$$s_n = \sigma_m - \tau_p.$$

For example, if the u -series is

$$1 - \frac{1}{2} + \frac{1}{3} - \frac{1}{4} + \cdots,$$

the v -series will be

$$1 + \frac{1}{3} + \frac{1}{5} + \cdots$$

and the $-w$ -series:

$$-\frac{1}{2} - \frac{1}{4} - \frac{1}{6} - \cdots.$$

When $n = \infty$, m and p will in general both increase without limit, and two cases can arise.

Case 1. Both σ_m and τ_p approach limits:

$$\lim_{m=\infty} \sigma_m = V, \quad \lim_{p=\infty} \tau_p = W;$$

i.e. both the v -series and the w -series converge. In this case the u -series converges,

$$\lim_{n=\infty} s_n = U, \quad \text{and} \quad U = V - W.$$

Case 2. At least one of the variables σ_m , τ_p diverges when $n = \infty$. In this case the u -series may still converge, as the above example shows. But if one of the auxiliary series converges and the other diverges, it is evident that s_n can approach no limit. Example:

$$1 - r + \frac{1}{2} - r^2 + \frac{1}{3} - r^3 + \cdots, \quad 0 < r < 1.$$

Absolutely Convergent Series. Let us form the series of the absolute values of the terms of the u -series:

* If, for a given value of n , no positive terms have as yet appeared, we will understand by σ_0 the value 0. Similarly, $\tau_0 = 0$.

$$|u_0| + |u_1| + \dots$$

Here $|u_n|$ will be a certain v if u_n is positive, a certain w if u_n is negative. If we set

$$s'_n = |u_0| + |u_1| + \dots + |u_{n-1}|,$$

then $s'_n = \sigma_m + \tau_p.$

Hence the series of absolute values converges if both the v -series and the w -series converge.

Conversely, if the series of absolute values converges, then both the v -series and the w -series converge and we have Case 1. For both of the latter series are series of positive terms, and no matter how many terms be added in either series, the sum cannot exceed the value U' of the series of absolute values. Hence by the Principle of § 3 each of these series converges.

Series whose absolute value series converge are said to be *absolutely* or *unconditionally* convergent; other convergent series are *conditionally* convergent.

We can now complete the proof of the theorem of § 5, namely, for the case that

$$\lim_{n \rightarrow \infty} \frac{u_{n+1}}{u_n} = t, \quad |t| < 1.$$

Here the series of absolute values converges, for

$$\frac{|u_{n+1}|}{|u_n|} = \left| \frac{u_{n+1}}{u_n} \right| \quad \text{and hence} \quad \lim_{n \rightarrow \infty} \frac{|u_{n+1}|}{|u_n|} = |t| < 1.$$

Consequently the u -series converges absolutely.

Example 1. To test the convergence of the series

$$x - \frac{x^2}{2} + \frac{x^3}{3} - \dots$$

Here $\frac{u_{n+1}}{u_n} = -\frac{n}{n+1}x, \quad \lim_{n \rightarrow \infty} \frac{u_{n+1}}{u_n} = -x,$

and hence the series converges when $-1 < x < 1$ and diverges outside of this interval.

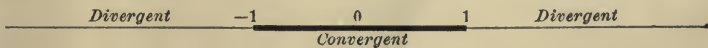

At the extremities of the interval the test fails. But we see directly that for $x=1$ the series is a convergent alternating series; for $x=-1$, the negative of the harmonic series, and hence divergent.

Example 2. The series

$$1 + nx + \frac{n(n-1)}{1 \cdot 2} x^2 + \frac{n(n-1)(n-2)}{1 \cdot 2 \cdot 3} x^3 + \dots$$

has for its general term, u_k :

$$u_k = \frac{n(n-1) \dots (n-k+1)}{k!} x^k.$$

If n is a positive integer, the later terms are all 0 and the series reduces to a polynomial, namely the binomial expansion of $(1+x)^n$. When n is not a positive integer, the value of the test-ratio is

$$\frac{u_{k+1}}{u_k} = \frac{n-k}{k+1} x, \quad \text{and} \quad \lim_{k \rightarrow \infty} \frac{u_{k+1}}{u_k} = -x.$$

Hence the series converges when $-1 < x < 1$ and diverges when $|x| > 1$. For the determination of whether the series is convergent or divergent at the extremities of the interval of convergence more elaborate tests are necessary.

EXERCISES

For what values of x are the following series convergent? Indicate the interval of convergence each time by a figure.

1. $1 + x + 2x^2 + 3x^3 + \dots$ *Ans.* $-1 < x < 1$.

2. $1 + x + \frac{x^2}{2!} + \frac{x^3}{3!} + \dots$

Ans. $-\infty < x < \infty$, i.e. for all values of x .

3. $x - \frac{x^3}{3} + \frac{x^5}{5} - \frac{x^7}{7} + \dots$

Ans. $-1 < x \leq 1$.

4. $1 - \frac{x^2}{2!} + \frac{x^3}{3!} - \frac{x^4}{4!} + \dots$

$$5. 2 \cdot 1x + 3 \cdot 2x^2 + 4 \cdot 3x^3 + \dots$$

$$6. x - \frac{x^3}{3!} + \frac{x^5}{5!} - \dots$$

$$7. x + \frac{x^3}{\sqrt{3}} + \frac{x^5}{\sqrt{5}} + \dots$$

$$8. 10x + 100x^2 + 1000x^3 + \dots$$

$$9. x + 2^{99}x^2 + 4^{99}x^4 + 6^{99}x^6 + \dots$$

$$10. 1 + x + 2!x^2 + 3!x^3 + \dots$$

$$11. 1 - mx + \frac{m(m-1)}{1 \cdot 2} x^2 - \frac{m(m-1)(m-2)}{1 \cdot 2 \cdot 3} x^3 + \dots$$

$$12. x + \frac{x^3}{3} + \frac{x^5}{5} + \dots$$

$$13. 1 + \frac{1}{2}x + \frac{1 \cdot 3}{2 \cdot 4}x^2 + \frac{1 \cdot 3 \cdot 5}{2 \cdot 4 \cdot 6}x^3 + \dots$$

$$14. x + \frac{1}{2} \frac{x^3}{3} + \frac{1 \cdot 3}{2 \cdot 4} \frac{x^5}{5} + \dots$$

$$15. 1 - \frac{x^2}{2} - \frac{1}{2} \frac{x^4}{4} - \frac{1 \cdot 3}{2 \cdot 4} \frac{x^6}{6} - \dots$$

8. Power Series. A series proceeding according to monomials in x of positive and steadily increasing degree:

$$a_0 + a_1x + a_2x^2 + \dots,$$

is called a *power series*. Such a series may converge for all values of x or for no value of x except 0; or it may converge for some values of x different from 0 and diverge for others. In the latter case the interval of convergence always reaches out to equal distances on each side of the point $x = 0$.

This latter statement is easily proven for such power series as ordinarily arise in practice. If we assume, namely, that

the ratio of two successive coefficients, a_{n+1}/a_n , approaches a limit:

$$\lim_{n \rightarrow \infty} \frac{a_{n+1}}{a_n} = L,$$

then the test-ratio test gives:

$$\lim_{n \rightarrow \infty} \frac{u_{n+1}}{u_n} = \lim_{n \rightarrow \infty} \frac{a_{n+1}}{a_n} x = Lx.$$

Hence if $L = 0$, the series converges for all values of x ; but if $L \neq 0$, the series converges when

$$|Lx| < 1, \quad \text{i.e.} \quad -|L| < x < |L|,$$

and diverges outside this interval.

9. Operations with Infinite Series. Since the value of an infinite series is not that of a fixed polynomial, but is the *limit* of a *variable* polynomial, we cannot expect that the ordinary algebraic processes that leave the value of a polynomial unchanged, such as rearranging the order of its terms, will always leave the value of the series unchanged. Nevertheless it can be shown that the terms in an *absolutely convergent* series can be rearranged at pleasure without changing the value of the series. Moreover, any two convergent series can be added term by term:

$$U = u_0 + u_1 + \dots,$$

$$V = v_0 + v_1 + \dots,$$

$$U + V = u_0 + v_0 + u_1 + v_1 + u_2 + \dots.$$

And two absolutely convergent series can be multiplied together like polynomials:

$$UV = u_0v_0 + u_0v_1 + u_1v_0 + u_0v_2 + u_1v_1 + u_2v_0 + \dots.$$

Hence, in particular, for power series, if

$$f(x) = a_0 + a_1x + a_2x^2 + \dots,$$

$$\phi(x) = b_0 + b_1x + b_2x^2 + \dots,$$

then

$$f(x)\phi(x) = a_0b_0 + (a_0b_1 + a_1b_0)x + (a_0b_2 + a_1b_1 + a_2b_0)x^2 + \dots.$$

The resulting series thus obtained will converge at least for all values of x lying within the smaller of the two intervals of convergence of the given series.

It is even possible to divide one power series by another as if they were both polynomials. We shall make use of this property in the next chapter when we come to develop $\tan x$.

An especially important operation with power series is that of differentiating or integrating the series term by term, *i.e.* as if it were a polynomial. For example, take the geometric progression:

$$\frac{1}{1-x} = 1 + x + x^2 + x^3 + \dots$$

Differentiating each side with respect to x , we have

$$\frac{1}{(1-x)^2} = 1 + 2x + 3x^2 + 4x^3 + \dots,$$

a result that can easily be verified by multiplying the first series by itself as explained above.

Again, integrating each side of the equation

$$\frac{1}{1+x} = 1 - x + x^2 - x^3 + \dots$$

between the limits 0 and h , we get, since

$$\int_0^h \frac{dx}{1+x} = \log(1+x) \Big|_0^h = \log(1+h),$$

the important series:

$$\log(1+h) = h - \frac{h^2}{2} + \frac{h^3}{3} - \dots$$

By means of this series and others immediately deduced from it natural and denary logarithms are computed.

In like manner we get from the series

$$\frac{1}{1+x^2} = 1 - x^2 + x^4 - \dots$$

a series for $\tan^{-1}h$:

$$\int_0^h \frac{dx}{1+x^2} = \tan^{-1} h = h - \frac{h^3}{3} + \frac{h^5}{5} - \dots$$

By means of this series the value of π can be expeditiously computed with great accuracy.

It is of value for the student at this stage, before proceeding to the further study of series, to see how the simpler series are actually used in practice as a means of computation. He is referred for a treatment of this subject to the *Infinite Series*, Chap. II: "Series as a Means of Computation," see the footnote at the beginning of this chapter.

The processes with infinite series, of which we have given a brief account in this paragraph, are also taken up and established in the *Infinite Series*, Chap. IV: "Algebraic Transformations of Series," and Chap. V: "Continuity, Integration, and Differentiation of Series." In the latter chapter will also be found a proof of the theorem that a power series always represents a continuous function throughout its whole interval of convergence.

EXERCISES

1. If $a_0 + a_1 + \dots$

is any absolutely convergent series and ρ_0, ρ_1, \dots any set of numbers, positive or negative, that merely remain finite as n increases: $|\rho_n| < G$, where G is a constant, show that the series

$$a_0 \rho_0 + a_1 \rho_1 + \dots$$

converges absolutely.

2. Prove that the series

$$\sin x - \frac{\sin 3x}{3^2} + \frac{\sin 5x}{5^2} - \dots$$

converges absolutely for all values of x .

3. If $a_0 + a_1 + \dots$ and $b_1 + b_2 + \dots$ are any two absolutely convergent series, the series

$$a_0 + a_1 \cos x + a_2 \cos 2x + \dots$$

and

$$b_1 \sin x + b_2 \sin 2x + \dots$$

converge absolutely.

4. Show that the series

$$e^{-x} \cos x + e^{-2x} \cos 2x + \dots$$

converges absolutely for all positive values of x .

5. What can you say about the convergence of the series

$$1 + r \cos \theta + r^2 \cos 2\theta + \dots ?$$

6. If

$$a_0 + a_1 + \dots$$

is an absolutely convergent series and if

$$u_0 + u_1 + \dots$$

is a series such that u_n/a_n approaches a limit when $n = \infty$, show that the latter series converges absolutely.

7. State and prove an analogous theorem for divergent series.

8. Show that the series

$$\frac{2x}{1-x^2} + \frac{2x}{4-x^2} + \frac{2x}{9-x^2} + \dots$$

converges for all values of x for which its terms all have a meaning.

9. Show that the series

$$\frac{a}{b+c} + \frac{a}{b+2c} + \frac{a}{b+3c} + \dots,$$

where a and c are $\neq 0$, diverges.

10. Is the series

$$\left(\frac{1}{x+1} - 1\right) + \left(\frac{1}{x+2} - \frac{1}{2}\right) + \left(\frac{1}{x+3} - \frac{1}{3}\right) + \dots$$

convergent or divergent?

CHAPTER XIII

TAYLOR'S THEOREM

1. Maclaurin's Series. The examples to which the student has been referred in the preceding paragraph show how useful it is for the purposes of computation to be able to represent a function by means of a series. Such a representation is also important as an aid in studying properties of the function. We turn now to a general method for representing any one of a large class of functions by power series, —for *developing* the function in a power series, to use the ordinary expression.

Suppose that it is possible to develop a function in a power series:

$$f(x) = c_0 + c_1x + c_2x^2 + \dots.$$

What values will the coefficients have? If we set $x=0$ we see that

$$f(0) = c_0,$$

and thus the first coefficient c_0 is determined.

To get the next coefficient, differentiate:

$$f'(x) = c_1 + 2c_2x + 3c_3x^2 + \dots,$$

and again let $x=0$:

$$f'(0) = c_1.$$

Thus c_1 is found. Proceeding in this manner we obtain:

$$f''(x) = 2 \cdot 1c_2 + 3 \cdot 2c_3x + 4 \cdot 3c_4x^2 + \dots,$$

$$f''(0) = 2 \cdot 1c_2, \quad c_2 = \frac{f''(0)}{2},$$

and so on; the general coefficient having the value

$$c_n = \frac{f^{(n)}(0)}{n!}.$$

Hence we see that, if $f(x)$ can be developed in powers of x , the series will have the form:

$$(1) \quad f(x) = f(0) + f'(0)x + \frac{f''(0)}{2!}x^2 + \dots$$

This series is known as *Maclaurin's Series*.

For example, let $f(x) = e^x$.

Here $f'(x) = e^x$, $f''(x) = e^x$, \dots $f^{(n)}(x) = e^x$,
and $f(0) = 1$, $f'(0) = 1$, $f''(0) = 1$, etc.

Hence the development will be as follows:

$$(2) \quad e^x = 1 + x + \frac{x^2}{2!} + \frac{x^3}{3!} + \dots$$

This series converges for all values of x .

EXERCISES

Assuming that the function can be developed in a Maclaurin's Series, obtain the following developments.

$$1. \quad \sin x = x - \frac{x^3}{3!} + \frac{x^5}{5!} - \dots$$

$$2. \quad \cos x = 1 - \frac{x^2}{2!} + \frac{x^4}{4!} - \dots$$

$$3. \quad a^x = 1 + x \log a + \frac{x^2 (\log a)^2}{2!} + \frac{x^3 (\log a)^3}{3!} + \dots$$

$$4. \quad (1+x)^n = 1 + nx + \frac{n(n-1)}{1 \cdot 2} x^2 + \frac{n(n-1)(n-2)}{1 \cdot 2 \cdot 3} x^3 + \dots$$

Obtain three terms in each of the following developments.

$$5. \quad \tan x = x + \frac{1}{3}x^3 + \frac{2}{15}x^5 + \dots$$

$$6. \quad \sec x = 1 + \frac{1}{2}x^2 + \frac{5}{24}x^4 + \dots$$

$$7. \quad e^{\sin x} = 1 + x + \frac{1}{2}x^2 - \frac{1}{8}x^4 + \dots$$

2. Taylor's Series. It may, however, happen that no development according to powers of x is possible. Thus if

$$f(x) = \log x,$$

$f(0) = -\infty$. But a power series represents a continuous function and so no power series in x can be expected to represent $\log x$. It is evident generally that, whenever the function or any one of its derivatives becomes discontinuous for $x=0$, the function cannot be developed in a Maclaurin's Series.

A power series is most useful for computation if the values we have to assign to its argument (*i.e.* the independent variable) are small. Now it may happen that we know the value of the function and of all its derivatives at a single point, $x=x_0$, or at least can easily compute them. In such a case we can find the value of the function at points $x=x_0+h$ near by if we develop $f(x)$, not according to powers of x , but according to powers of h . Setting, then,

$$x = x_0 + h, \quad h = x - x_0,$$

we shall have, if a development be possible :

$$f(x) = f(x_0 + h) = c_0 + c_1 h + c_2 h^2 + \dots$$

We can determine the coefficients here as in the case of Maclaurin's Series. Thus, setting $h=0$, we find,

$$f(x_0) = c_0.$$

Differentiating with respect to h and remembering that x_0 is a constant, we obtain :

$$\frac{d f(x)}{d h} = \frac{d f(x)}{d x} \frac{d x}{d h} = f'(x) =$$

$$f'(x_0 + h) = c_1 + 2 c_2 h + 3 c_3 h^2 + \dots,$$

$$f'(x_0) = c_1;$$

$$f''(x_0 + h) = 2 \cdot 1 c_2 + 3 \cdot 2 c_3 h + 4 \cdot 3 c_4 h^2 + \dots,$$

$$f''(x_0) = 2 \cdot 1 c_2, \quad c_2 = \frac{f''(x_0)}{2!},$$

and so on :
$$c_n = \frac{f^{(n)}(x_0)}{n!}$$

If, then, $f(x)$ can be developed in powers of h , the series will have the form :

$$(3) \quad f(x_0 + h) = f(x_0) + f'(x_0)h + \frac{f''(x_0)}{2!}h^2 + \dots$$

When h is replaced by x , (3) becomes :

$$(3') \quad f(x) = f(x_0) + f'(x_0)(x - x_0) + \frac{f''(x_0)}{2!}(x - x_0)^2 + \dots$$

These series are known as *Taylor's Series*.

For example, let

$$f(x) = \log x, \quad x_0 = 1.$$

Then

$$f'(x) = \frac{1}{x}, \quad f'(1) = 1;$$

$$f''(x) = \frac{-1}{x^2}, \quad f''(1) = -1;$$

$$f'''(x) = \frac{2 \cdot 1}{x^3}, \quad f'''(1) = 2!;$$

.

$$f^{(n)}(x) = (-1)^{n+1} \frac{(n-1)!}{x^n}, \quad f^{(n)}(1) = (-1)^{n+1} (n-1)!,$$

and the series will have the form :

$$\log(1 + h) = h - \frac{h^2}{2} + \frac{h^3}{3} - \dots$$

This agrees with the result obtained by integration in the preceding chapter. The series converges for values of h numerically less than 1.

Maclaurin's Series is a special case of Taylor's Series, obtained by letting $x_0 = 0$. But conversely, Taylor's Series can be obtained from Maclaurin's by replacing x by h as above and developing $f(x_0 + h)$ in a Maclaurin's Series.

EXERCISES

Assuming that the function can be developed in a Taylor's Series, obtain the following developments.

$$1. e^{a+h} = e^a + e^a h + \frac{e^a}{2!} h^2 + \dots$$

$$2. \sin(x_0 + h) = \sin x_0 + h \cos x_0 - \frac{h^2}{2!} \sin x_0 - \frac{h^3}{3!} \cos x_0 + \dots$$

$$3. \cos\left(\frac{\pi}{4} + h\right) = \frac{1}{\sqrt{2}} \left[1 - h - \frac{h^2}{2!} + \frac{h^3}{3!} + \dots \right]$$

$$4. x^n = (a+h)^n = a^n + n a^{n-1} h + \frac{n(n-1)}{1 \cdot 2} a^{n-2} h^2 + \frac{n(n-1)(n-2)}{1 \cdot 2 \cdot 3} a^{n-3} h^3 + \dots$$

$$5. \sin\left(\frac{\pi}{6} + h\right) = \frac{1}{2} + \frac{\sqrt{3}}{2} h - \frac{1}{2} \frac{h^2}{2!} - \frac{\sqrt{3}}{2} \frac{h^3}{3!} + \dots$$

$$6. \log x = \log 2 + \frac{x-2}{2} - \frac{1}{2} \frac{(x-2)^2}{2^2} + \frac{1}{3} \frac{(x-2)^3}{2^3} - \dots$$

Obtain three terms in the development of each of the following functions.

$$7. \log(1+x^2), \quad x_0 = 3.$$

$$\text{Ans. } 2.303 + .6(x-3) - .08(x-3)^2 + \dots$$

$$8. \tan x, \quad x_0 = \frac{\pi}{4}.$$

$$10. \frac{\sqrt{1-x}}{x}, \quad x_0 = -1.$$

$$9. \log(e^x + e^{-x}), \quad x_0 = 0.$$

$$11. 10^x, \quad x_0 = 0.$$

3. Proof of Taylor's Theorem. Let the function $f(x)$ be continuous throughout the interval $a \leq x \leq b$ and let it have continuous derivatives of all orders throughout this interval. Let x_0 be an arbitrary point of the interval, which, once chosen, shall be held fast, and let $x_0 + h$ be any second point of the interval. We will see if we can approximate to the value of the function by means of the first $n + 1$ terms of the corresponding Taylor's Series:

$$(4) \quad f(x_0 + h) = f(x_0) + f'(x_0)h + \dots + \frac{f^{(n)}(x_0)}{n!}h^n + R,$$

where R denotes the error, *i.e.* the difference between the value of the function and the value of the approximation. In order to see how good this approximation is, we must have an expression for R that will throw light on the numerical value of this quantity. Such an expression can be found as follows.

Let us write R in the form :

$$R = \frac{h^{n+1}}{(n+1)!}P, \quad \textit{i.e.} \quad \text{let} \quad P = R \div \frac{h^{n+1}}{(n+1)!}.$$

Then (4) becomes, on transposing terms :

$$(5) \quad f(x_0 + h) - f(x_0) - hf'(x_0) - \dots - \frac{h^n}{n!}f^{(n)}(x_0) - \frac{h^{n+1}}{(n+1)!}P = 0.$$

We now proceed to form arbitrarily the following function of z :

$$\begin{aligned} \phi(z) = f(X) - f(z) - (X-z)f'(z) - \frac{(X-z)^2}{2!}f''(z) - \dots \\ - \frac{(X-z)^n}{n!}f^{(n)}(z) - \frac{(X-z)^{n+1}}{(n+1)!}P. \end{aligned}$$

Here $X = x_0 + h$, and X and P are constants. This function satisfies all the conditions of Rolle's Theorem in the interval $x_0 \leq z \leq X$. For $\phi(X)$ is obviously $= 0$, and if we compare $\phi(x_0)$ with the left-hand side of (5), we see that $\phi(x_0)$ vanishes, too. Hence the derivative of $\phi(z)$ must vanish at some point within the interval. Now, on computing the derivative we find that the terms cancel each other to a large extent :*

$$\begin{aligned} \phi'(z) = -f'(z) + f'(z) - (X-z)f''(z) + (X-z)f''(z) - \\ \dots - \frac{(X-z)^n}{n!}f^{(n+1)}(z) + \frac{(X-z)^n}{n!}P, \end{aligned}$$

so that there remain finally only two terms :

* The student is requested to write out the terms in this differentiation for $n = 1, 2$, and 3 .

$$\phi'(z) = -\frac{(X-z)^n}{n!} f^{(n+1)}(z) + \frac{(X-z)^n}{n!} P.$$

Consequently the conclusion of Rolle's Theorem:

$$\phi'(Z) = 0, \quad x_0 < Z < X \quad \text{or} \quad Z = x_0 + \theta h, \quad 0 < \theta < 1,$$

leads to the result,

$$(6) \quad P = f^{(n+1)}(x_0 + \theta h), \quad R = \frac{h^{n+1}}{(n+1)!} f^{(n+1)}(x_0 + \theta h).$$

Thus we obtain one of the most important theorems of the Calculus, *Taylor's Theorem with the Remainder*: *

$$(7) \quad f(x_0 + h) = f(x_0) + f'(x_0)h + \frac{f''(x_0)}{2!}h^2 + \dots + \frac{f^{(n)}(x_0)}{n!}h^n \\ + \frac{h^{n+1}}{(n+1)!} f^{(n+1)}(x_0 + \theta h), \quad 0 < \theta < 1.$$

If we set $n = 0$, thus stopping with the second term, we get the Law of the Mean:

$$f(x_0 + h) = f(x_0) + hf'(x_0 + \theta h).$$

If $n = 1$, we have:

$$f(x_0 + h) = f(x_0) + hf'(x_0) + \frac{h^2}{2!} f''(x_0 + \theta h).$$

If we allow n to increase without limit, the first $n + 1$ terms of (7) become an infinite series, the Taylor's Series corresponding to the function $f(x)$. *In order that this series should converge and represent the function it is necessary and sufficient that*

$$(8) \quad \lim_{n \rightarrow \infty} R = 0.$$

When the condition (8) is satisfied, we say that the function can be *developed* or *expanded* by *Taylor's Theorem about the point* $x = x_0$.

* In the foregoing proof we have made no use of that part of the assumption regarding $f(x)$ which relates to derivatives of higher order than $n + 1$, and consequently our theorem is somewhat more general than would appear in the text.

4. A Second Form for the Remainder. A form of the remainder which is obtained by setting

$$R = hP,$$

and proceeding as in § 3, is sometimes useful. Thus we have

$$f(x_0 + h) - f(x_0) - hf'(x_0) - \dots - \frac{h^n}{n!} f^{(n)}(x_0) - hP = 0,$$

and we form the function of z ,

$$\begin{aligned} \phi(z) = f(X) - f(z) - (X-z)f'(z) - \frac{(X-z)^2}{2!} f''(z) - \\ \dots - \frac{(X-z)^n}{n!} f^{(n)}(z) - (X-z)P, \end{aligned}$$

where $X = x_0 + h$. This function satisfies the conditions of Rolle's Theorem in the interval $x_0 \leq z \leq X$, and so its derivative,

$$\phi'(z) = -\frac{(X-z)^n}{n!} f^{(n+1)}(z) + P,$$

must vanish at some point $Z = x_0 + \theta h$ within the interval. Hence,

$$(9) \quad R = \frac{(1-\theta)^n h^{n+1}}{n!} f^{(n+1)}(x_0 + \theta h).$$

5. Development of e^x , $\sin x$, $\cos x$. The function e^x can be developed by Taylor's Theorem about the point $x_0 = 0$. Here

$$f(x) = e^x, \quad f'(x) = e^x, \quad \dots \quad f^{(n)}(x) = e^x,$$

$$f(0) = 1, \quad f'(0) = 1, \quad \dots \quad f^{(n)}(0) = 1,$$

and the remainder R as given by (6) has the form:

$$R = \frac{h^{n+1}}{(n+1)!} e^{\theta h}.$$

$$\text{If } h < 0, \quad e^{\theta h} < 1, \quad \text{and} \quad R < \frac{|h|^{n+1}}{(n+1)!}.$$

$$\text{If } h > 0, \quad e^{\theta h} < e^h, \quad \text{and} \quad R < \frac{h^{n+1}}{(n+1)!} e^h.$$

$$\text{Now} \quad \lim_{n \rightarrow \infty} \frac{h^{n+1}}{(n+1)!} = 0.$$

For we can write

$$\frac{h^{n+1}}{(n+1)!} = \frac{h}{1} \cdot \frac{h}{2} \cdot \frac{h}{3} \cdot \dots \cdot \frac{h}{n} \cdot \frac{h}{n+1}.$$

No matter how large h may be numerically, since it is *fixed* and n is *variable*, these factors ultimately become small, and hence from a definite point $n = m$ on

$$\frac{|h|}{n} < \frac{1}{2}, \quad n \geq m.$$

If we denote, then, the product of the first m factors, taken numerically, by C , and replace each of the subsequent factors by $\frac{1}{2}$, we shall have:

$$\left| \frac{h^{n+1}}{(n+1)!} \right| < C \left(\frac{1}{2} \right)^{n-m+1}.$$

The limit of this last expression is 0 when $n = \infty$, and consequently $\lim_{n=\infty} h^{n+1} / (n+1)! = 0$.

We have, then, $\lim_{n=\infty} R = 0$ and hence, replacing h by x :

$$(10) \quad e^x = 1 + x + \frac{x^2}{2!} + \frac{x^3}{3!} + \dots$$

The series converges and represents the function for all values of x .

To develop $\sin x$ we observe that

$$\begin{aligned} f(x) &= \sin x, & f(0) &= 0, \\ f'(x) &= \cos x, & f'(0) &= 1, \\ f''(x) &= -\sin x, & f''(0) &= 0, \\ f'''(x) &= -\cos x, & f'''(0) &= -1, \end{aligned}$$

and from this point on these values repeat themselves.

It is not difficult to get a general expression for the n -th derivative, namely:

* We might have given a short proof of this relation by observing that $h^{n+1} / (n+1)!$ is the general term of a convergent series:

$$1 + h + \frac{h^2}{2!} + \frac{h^3}{3!} + \dots$$

$$f^{(n)}(x) = \sin\left(x + \frac{n\pi}{2}\right).$$

This formula obviously holds for $n = 1, 2, 3, 4$, and from that point on the right-hand member repeats itself, as it should.

Thus we find:

$$R = \frac{h^{n+1}}{(n+1)!} \sin\left(\theta h + \frac{n\pi}{2}\right).$$

The second factor is never greater than 1 numerically, and the first factor, as we have just seen, approaches 0 as its limit. Hence $\lim_{n \rightarrow \infty} R = 0$ and we have, on replacing h by x :

$$(11) \quad \sin x = x - \frac{x^3}{3!} + \frac{x^5}{5!} - \dots$$

In a similar manner it is shown that

$$(12) \quad \cos x = 1 - \frac{x^2}{2!} + \frac{x^4}{4!} - \dots$$

EXERCISES

1. Compute the value of $e^{.06}$ (cf. Chap. IV, § 7) to six significant figures.
2. Show that e^x can be developed by Taylor's Theorem about any point x_0 .
3. Obtain a general expression for the n -th derivative of $\cos x$ and hence prove the development (12).
4. Show that $\sin x$ and $\cos x$ can be developed by Taylor's Theorem about any point x_0 .
5. Remembering that 1° is equal to $\pi/180$ radians, compute $\sin 1^\circ$ correct to six significant figures. By about what percentage of either does $\sin 1^\circ$ differ from its arc in the unit circle?

6. The Binomial Theorem. Let

$$f(x) = x^n,$$

where n is any constant, integral, fractional, or incommensurable, positive or negative; and let $x_0 = 1$.

Then $f(1) = 1$ and

$$\begin{aligned} f'(x) &= nx^{n-1}, & f'(1) &= n, \\ f''(x) &= n(n-1)x^{n-2}, & f''(1) &= n(n-1), \\ & \dots & & \dots \end{aligned}$$

$$\begin{aligned} f^{(k)}(x) &= n(n-1)\dots(n-k+1)x^{n-k}, \\ f^{(k)}(1) &= n(n-1)\dots(n-k+1). \end{aligned}$$

For the remainder R it is better here to employ the second form, (9). Thus

$$\begin{aligned} R &= \frac{(1-\theta)^k h^{k+1}}{k!} \cdot n(n-1)\dots(n-k)(1+\theta h)^{n-k-1} \\ &= \frac{n(n-1)\dots(n-k)}{k!} h^{k+1} \left(\frac{1-\theta}{1+\theta h}\right)^k (1+\theta h)^{n-1}. \end{aligned}$$

The last factor remains finite, whatever the value of θ , provided $|h| < 1$. For, since $0 < \theta < 1$,

$$1 - |h| < 1 + \theta h < 1 + |h|,$$

and by Chap. II, § 8:

$$\begin{aligned} (1 + \theta h)^{n-1} &< (1 + |h|)^{n-1}, & n > 1; \\ (1 + \theta h)^{n-1} &< (1 - |h|)^{n-1}, & n < 1. \end{aligned}$$

The next to the last factor is always positive and less than unity, since $k > 0$ and

$$0 < \frac{1-\theta}{1+\theta h} < 1.$$

Finally, the remaining expression is the general term of a series already shown to be convergent, namely (cf. Chap. XII, § 7):

$$1 + nh + \frac{n(n-1)}{1 \cdot 2} h^2 + \frac{n(n-1)(n-2)}{1 \cdot 2 \cdot 3} h^3 + \dots, \quad -1 < h < 1,$$

and hence it approaches 0 as its limit. It follows, then, that R approaches 0 and we have on replacing h by x :

$$(13) \quad (1+x)^n = 1 + nx + \frac{n(n-1)}{1 \cdot 2} x^2 + \frac{n(n-1)(n-2)}{1 \cdot 2 \cdot 3} x^3 + \dots$$

This is the Binomial Theorem for negative and fractional exponents. When n is 0 or a positive integer, the series breaks off of itself with a finite number of terms and we have a polynomial, namely: $(1+x)^n$. In all other cases the series converges when x is numerically less than 1 and represents the function $(1+x)^n$; and it diverges when x is numerically greater than 1.

The following developments obtained from (13) are especially useful.

$$(14) \quad \frac{1}{\sqrt{1-x^2}} = 1 + \frac{1}{2}x^2 + \frac{1 \cdot 3}{2 \cdot 4}x^4 + \frac{1 \cdot 3 \cdot 5}{2 \cdot 4 \cdot 6}x^6 + \dots$$

$$(15) \quad \sqrt{1-x^2} = 1 - \frac{1}{2}x^2 - \frac{1}{2 \cdot 4}x^4 - \frac{1 \cdot 3}{2 \cdot 4 \cdot 6}x^6 - \dots$$

*Just for
fasc. Ten
of right-
manuscript*

EXERCISES

1. Show that, when $|a| > |b|$:

$$(a+b)^n = a^n + na^{n-1}b + \frac{n(n-1)}{1 \cdot 2} a^{n-2}b^2 + \frac{n(n-1)(n-2)}{1 \cdot 2 \cdot 3} a^{n-3}b^3 + \dots$$

2. Compute $\sqrt[3]{3}$ correct to seven significant figures by means of the series (13).

SUGGESTION: Begin by writing $3 = (\frac{7}{4})^2 (\frac{48}{49})$. Here $\frac{7}{4}$ is one of the convergents in the development of $\sqrt[3]{3}$ by continued fractions.

3. Compute $\sqrt[5]{30}$ to five significant figures.

4. Obtain from (13) the development:

$$\frac{1}{(1+x)^2} = 1 - 2x + 3x^2 - 4x^3 + \dots$$

5. Obtain the development:

$$\log(1+h) = h - \frac{h^2}{2} + \frac{h^3}{3} - \dots$$

by the method of this paragraph.

7. Development of $\sin^{-1}x$. We can now obtain the development of $\sin^{-1}x$ in a manner similar to that employed for $\tan^{-1}x$. Integrating each side of (14) gives:

$$\int_0^h \frac{dx}{\sqrt{1-x^2}} = h + \frac{1}{2} \frac{h^3}{3} + \frac{1 \cdot 3}{2 \cdot 4} \frac{h^5}{5} + \dots$$

The value of the left-hand side is $\sin^{-1}h$. Hence, replacing h by x , we have:

$$(16) \quad \sin^{-1}x = x + \frac{1}{2} \frac{x^3}{3} + \frac{1 \cdot 3}{2 \cdot 4} \frac{x^5}{5} + \dots$$

The series converges and represents the function when $|x| < 1$.

8. Development of $\tan x$. We have:

$$\tan x = \frac{\sin x}{\cos x} = \frac{x - \frac{1}{6}x^3 + \frac{1}{120}x^5 - \dots}{1 - \frac{1}{2}x^2 + \frac{1}{24}x^4 - \dots}$$

Now it can be shown that one power series can be divided by another just as if both were polynomials, the resulting series converging throughout a certain interval, cf. *Infinite Series*, § 36. Hence

$$1 - \frac{1}{2}x^2 + \frac{1}{24}x^4 \dots \overline{) \begin{array}{l} x + \frac{1}{3}x^3 + \frac{2}{15}x^5 + \dots \\ x - \frac{1}{6}x^3 + \frac{1}{120}x^5 - \dots \\ \hline x - \frac{1}{2}x^3 + \frac{1}{24}x^5 - \dots \\ \frac{1}{3}x^3 - \frac{1}{30}x^5 + \dots \\ \hline \frac{1}{3}x^3 - \frac{1}{6}x^5 + \dots \\ \frac{2}{15}x^5 + \dots \end{array}}$$

We can obtain in this way as many terms in the development of $\tan x$ as we wish, although the law of the series does not become obvious.

$$(17) \quad \tan x = x + \frac{1}{3}x^3 + \frac{2}{15}x^5 + \dots$$

9. Applications. We shall consider here only two or three applications of Taylor's Theorem, referring the student for further applications to the *Infinite Series*, Chaps. II, III, and IV.

(1) *Test for Maxima, Minima, and Points of Inflection.* We can now state wider sufficient conditions for maxima, minima, and points of inflection than those given in Chap. III.

Suppose that the function $f(x)$, together with its first n derivatives, is continuous in the neighborhood of the point $x = x_0$ and that

$$f'(x_0) = 0, \quad f''(x_0) = 0, \quad \dots \quad f^{(n-1)}(x_0) = 0,$$

but that $f^{(n)}(x_0) \neq 0$.

Then we shall have, by Taylor's Theorem with the Remainder, Formula (7):

$$(18) \quad f(x_0 + h) - f(x_0) = h^n f^{(n)}(x_0 + \theta h) / n!$$

If n is even, h^n will be positive on both sides of the point $h = 0$, $x = x_0$; and since $f^{(n)}(x)$ is continuous, it will preserve the sign it has at x_0 throughout a certain interval about this point:

$$x_0 - a < x < x_0 + a, \quad -a < h < a.$$

Hence the right-hand side of (18) is positive, or else it is negative, when $0 < |h| < a$ and thus we are led to the following

TEST FOR A MAXIMUM OR A MINIMUM. *If*

$$f'(x_0) = 0, \quad f''(x_0) = 0, \quad \dots \quad f^{(2m-1)}(x_0) = 0, \quad f^{(2m)}(x_0) \neq 0,$$

the function $f(x)$ will have

a maximum at $x = x_0$ if $f^{(2m)}(x_0) < 0$;

a minimum " " " $f^{(2m)}(x_0) > 0$.

If, on the other hand, n is odd, the right-hand side of (18) will change sign with h and we shall have a point of inflection parallel to the axis of x . More generally, since the condition for a point of inflection, be it parallel to the axis of x or not, is that $\tan \tau = f'(x)$ be at a maximum or a minimum, we deduce

from the test just obtained, applied, not to $f(x)$, but to $f'(x) = \tan \tau$, the following

TEST FOR A POINT OF INFLECTION. *If*

$$f''(x_0) = 0, \quad f'''(x_0) = 0, \quad \dots \quad f^{(2m)}(x_0) = 0, \quad f^{(2m+1)}(x_0) \neq 0,$$

the curve $y=f(x)$ has a point of inflection in the point (x_0, y_0) .

(2) *Order of Contact of Two Curves.* Let two curves, C_1 and C_2 , be tangent to each other at an ordinary point P of either curve, and draw their common tangent PT . At a point M of PT infinitely near to P (by this is meant that M is taken conveniently near to P and is later going to be made to approach P as its limit) erect a perpendicular cutting C_1 in P_1 and C_2 in P_2 . PM and the arcs PP_1, PP_2 are obviously all infinitesimals of the same order. It will be convenient to take PM as the principal infinitesimal. Denote by n the order of the infinitesimal P_1P_2 . Then the curves C_1 and C_2 are said to have *contact of the $n - 1$ st order*.

For example, the parabola

$$C_1: \quad y = x^2$$

has contact of the first order with its tangent at its vertex:

$$C_2: \quad y = 0.$$

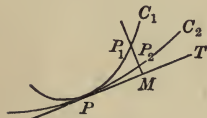

FIG. 78

But the curve $y = x^3$ has contact of the second order with its tangent at the origin; this point being a point of inflection for the latter curve. And the curves

$$y = x^3, \quad y = x^3 - x^4$$

have contact of the third order.

Since we can always transform our coördinate axes so that the tangent PT will be parallel to the axis of x —such a transformation evidently has no influence on the order of contact of the curves—we may without loss of generality assume the equations of the curves in the form

$$C_1: \quad y = f(x),$$

$$C_2: \quad y = \phi(x),$$

where $y_0 = f(x_0) = \phi(x_0)$ and $f'(x_0) = 0$, $\phi'(x_0) = 0$.

Hence, by Taylor's Theorem with the Remainder, (7):

$$C_1: \quad y - y_0 = \frac{h^2}{2!} f''(x_0) + \dots + \frac{h^n}{n!} f^{(n)}(x_0 + \theta h),$$

$$C_2: \quad y - y_0 = \frac{h^2}{2!} \phi''(x_0) + \dots + \frac{h^n}{n!} \phi^{(n)}(x_0 + \theta' h).$$

The infinitesimal P_1P_2 on which the order of contact of these curves depends is numerically equal to the difference between the ordinate y of C_1 and the ordinate y of C_2 , i.e. to

$$(19) \quad \frac{h^2}{2} [f''(x_0) - \phi''(x_0)] + \dots + \frac{h^n}{n!} [f^{(n)}(x_0 + \theta h) - \phi^{(n)}(x_0 + \theta' h)].$$

Now the curvature of these curves at the point (x_0, y_0) is, since $f'(x_0) = 0$ and $\phi'(x_0) = 0$:

$$\kappa_1 = |f''(x_0)|, \quad \kappa_2 = |\phi''(x_0)|.$$

Hence the curves will have contact of the first order if they have different curvatures at P , or if they have the same curvature ($\neq 0$), one curve being concave upward and the other concave downward. But if they have the same curvature and (in case the curvature of both is $\neq 0$) if they both present their concave side in the same direction, then they will have contact of at least the second order. Thus at an ordinary point a curve has contact of the first order with its tangent.

In particular, let C_2 be the osculating circle of C_1 at P . Then C_2 has the same curvature as C_1 and is concave toward the same side of the tangent. Hence it has in general contact of the second order with C_1 ; but at special points it may have contact of higher order.

At an ordinary point of inflection the tangent line has contact of the second order with the curve. For here, if we take C_2 as the tangent line, $\phi(x) = 0$ for all values of x , and hence the derivatives $\phi''(x_0)$, $\phi'''(x_0)$, etc. all vanish. On the other hand, $f''(x_0) = 0$, $f'''(x_0) \neq 0$. Consequently (19) becomes

$$\frac{h^3}{3!} f'''(x_0 + \theta h) \quad \text{and} \quad \lim_{h \rightarrow 0} \frac{P_1 P_2}{h^3} = \frac{1}{6} f'''(x_0) \neq 0.$$

(3) *Evaluation of the Limits* $\frac{0}{0}$, $\infty - \infty$, etc. The limit of the fraction

$$\lim_{x \rightarrow a} \frac{f(x)}{F(x)},$$

when $f(a) = 0$ and $F(a) = 0$, can be obtained without the labor of differentiating whenever the numerator and the denominator can be expressed as power series in terms of $x - a = h$. For example, to find

$$\lim_{x \rightarrow 0} \frac{x - \sin x}{x - \tan x}.$$

By the aid of the series for $\sin x$ and $\tan x$, we have

$$\frac{x - \sin x}{x - \tan x} = \frac{\frac{1}{6}x^3 + \text{higher powers of } x}{-\frac{1}{3}x^3 + \text{higher powers of } x}.$$

Hence, cancelling x^3 from the numerator and the denominator, we see that the value of the limit is $-\frac{1}{2}$.

The method of series is often of service in evaluating the limit $\infty - \infty$. For example, to find

$$\lim_{x \rightarrow \infty} (\sqrt{1 + x^2} - x).$$

Here we can take out x as a factor:

$$x \left(\sqrt{1 + \frac{1}{x^2}} - 1 \right),$$

and then express the radical, since $x > 1$, as a series in $1/x$ by means of the Binomial Theorem:

$$\sqrt{1 + \frac{1}{x^2}} = 1 + \frac{1}{2} \cdot \frac{1}{x^2} + \frac{3}{8} \cdot \frac{1}{x^4} + \dots$$

Hence
$$x \left(\sqrt{1 + \frac{1}{x^2}} - 1 \right) = \frac{1}{2} \cdot \frac{1}{x} + \frac{3}{8} \cdot \frac{1}{x^3} + \dots$$

When $x = \infty$, the terms of this power series in $1/x$ approach 0 as their limit, and since a power series represents a continuous function, the value of the limit in question is seen to be 0.

EXERCISES

1. Show that the function

$$y = 2 \cos x + x \sin x$$

has a maximum when $x = 0$.

2. Have the following functions maxima, minima, or points of inflection when $x = 0$?

(a) $5 \sin x - 4 \sin 2x + \sin 3x$.

(b) $2x^3 - 3e^x + 6 \sin x + \frac{3}{e^x}$.

(c) $15 \cos x - 6 \cos 2x + \cos 3x$.

3. Determine all the maxima, minima, and points of inflection of the function

$$y = \frac{1}{2}x - \frac{2}{3} \sin x + \frac{1}{12} \sin 2x,$$

and hence plot the graph.

4. Show that the curve $y = \cos x$ has contact of the fifth order at the point $(0, 1)$ with the curve

$$y = 1 - \frac{1}{2}x^2 + \frac{1}{24}x^4.$$

5. Show that the curve $y = \sin x$ has contact of the sixth order at the origin with the curve

$$y = x - \frac{1}{6}x^3 + \frac{1}{120}x^5.$$

6. Determine the parabola

$$y = a + bx + cx^2$$

so that it shall have contact of the second order with the curve $y = e^x$, when $x = 0$.

7. The same when $x = 1$.

Ans. $y = \frac{1}{2}e + \frac{1}{2}ex^2$.

8. Show that, when the function $f(x)$ is represented by a Taylor's Series, the n -th approximation curve:

$$y = s_n(x) = f(x_0) + f'(x_0)(x - x_0) + \dots + \frac{f^{(n)}(x_0)}{n!}(x - x_0)^n,$$

has contact of at least the n -th order with the curve $y = f(x)$ at the point (x_0, y_0) . When will it have contact of higher order?

9. Show that the curve

$$y = \frac{\alpha x + \beta}{\gamma x + \delta}$$

can in general be so determined as to have contact of the second order with the curve $y = f(x)$ at the point (x_0, y_0) . For simplicity, assume $x_0 = 0$ and $y_0 = 0$.

What cases are exceptions?

10. Show that

$$(a) \int_0^1 \frac{\log(1+x)}{x} dx = 1 - \frac{1}{2^2} + \frac{1}{3^2} - \dots$$

$$(b) \int_0^1 \frac{x^{a-1}}{1+x^b} dx = \frac{1}{a} - \frac{1}{a+b} + \frac{1}{a+2b} - \dots, \quad (a > 0).$$

$$(c) \int_0^{\infty} e^{-x^2} dx = x - \frac{x^3}{3} + \frac{x^5}{5 \cdot 2!} - \frac{x^7}{7 \cdot 3!} + \dots$$

11. Evaluate to three significant figures

$$\int_0^{\pi} \frac{\sin x}{x} dx.$$

Evaluate the following limits:

$$12. \lim_{x \rightarrow 0} \left(\cot x - \frac{1}{x} \right). \text{ Ans. } 0. \quad 13. \lim_{x \rightarrow \infty} (\sqrt{1+x} - x). \text{ Ans. } -\infty.$$

$$14. \lim_{x \neq 0} \left(\frac{\sin x}{x} \right)^{\frac{1}{x}}. \quad \text{Ans. } 1. \quad 16. \lim_{x \neq 0} \left(\frac{\sin x}{x} \right)^{\frac{1}{x^3}}. \quad \text{Ans. } 0.$$

$$15. \lim_{x \neq 0} \left(\frac{\sin x}{x} \right)^{\frac{1}{x^2}}. \quad \text{Ans. } \frac{1}{\sqrt{e}}. \quad 17. \lim_{x \neq 0} (\cos x)^{\frac{1}{x^2}}. \quad \text{Ans. } \frac{1}{\sqrt{e}}.$$

18. Show that, when two curves have contact of even order, they cross each other; when they have contact of odd order, they do not cross.

19. If $f(x) < \phi(x)$
is $\frac{d}{dx} f(x) < \frac{d}{dx} \phi(x) \quad ?$

20. If $\frac{df(x)}{dx} > \frac{d\phi(x)}{dx}$

and $f(x_0) = \phi(x_0),$

is $f(x_0 + h) \begin{matrix} \geq \\ < \end{matrix} \phi(x_0 + h), \quad h > 0 \quad ?$

21. Show that $\sin \alpha - \alpha$
is an infinitesimal of the third order, referred to α as principal infinitesimal.

22. Determine the order of the infinitesimal $\cos \alpha - e^{-\frac{\alpha^2}{2}}.$

23. Show that the equation

$$\phi \sin \phi = 1$$

has one and only one root lying between 0 and $\pi/2$.

$$\therefore \pi - \frac{\pi^3}{8} = 3.1416 - \frac{3.1416^3}{8} = \frac{3.1416^3}{8}$$

CHAPTER XIV

PARTIAL DIFFERENTIATION

1. Functions of Several Variables. Limits and Continuity.

We shall consider in this chapter functions that depend on more than one variable. Thus the area z of a rectangle is the product of its two sides, x and y :

$$z = xy;$$

and the volume u of a rectangular parallelepiped is the product of its three edges x , y , and z :

$$u = xyz.$$

If the number of independent variables is two, we can represent the function

$$(1) \quad z = f(x, y)$$

geometrically as a surface.

Such a function is said to be continuous at the point (x_0, y_0, z_0) if a small change in the values of x and y gives rise only to a small change in the value of the function. And the function is said to approach a limit, z_0 , when the point (x, y) approaches (x_0, y_0) , if the point (x, y, z) of the surface (1) approaches a limiting point (x_0, y_0, z_0) in space, no matter how the point (x, y) in the plane may approach the point (x_0, y_0) as its limit.

To formulate this latter definition in a more precise manner and at the same time in a way that is applicable to functions of more than two variables, let ϵ be an arbitrarily small positive quantity. If a positive δ can be found such that

$$|f(x, y) - z_0| < \epsilon$$

for all points (x, y) ,— except, of course, (x_0, y_0) ,— which lie in the neighborhood of (x_0, y_0) :

$$|x - x_0| < \delta, \quad |y - y_0| < \delta,$$

then $f(x, y)$ is said to *approach* z_0 as its limit, and we write:

$$\lim_{x \rightarrow x_0, y \rightarrow y_0} f(x, y) = z_0.$$

This conception once being made precise, we can now render the former one accurate by saying: $f(x, y)$ is *continuous* at the point (x_0, y_0) if

$$\lim_{x \rightarrow x_0, y \rightarrow y_0} f(x, y) = f(x_0, y_0).$$

2. Formulas of Solid Analytic Geometry. In what follows we shall need only the simplest formulas of solid analytic geometry, and we set them down here, referring the student for the proofs to any of the current texts.*

Direction Cosines. If α, β, γ denote the angles that a line makes respectively with the axes of x, y , and z , its direction cosines satisfy the relation:

$$(2) \quad \cos^2 \alpha + \cos^2 \beta + \cos^2 \gamma = 1.$$

The angle θ between two lines is given by the equation:

$$(3) \quad \cos \theta = \cos \alpha \cos \alpha' + \cos \beta \cos \beta' + \cos \gamma \cos \gamma'.$$

If l, m, n and l', m', n' are the direction cosines of two lines, or quantities proportional to them:

$$l = \rho \cos \alpha, \quad m = \rho \cos \beta, \quad n = \rho \cos \gamma; \quad l' = \rho' \cos \alpha', \quad \text{etc.},$$

then the necessary and sufficient condition that the lines be perpendicular to each other is that

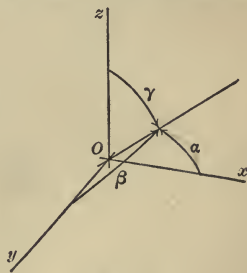

FIG. 79

* Cf. for example Bailey and Woods, *Analytic Geometry*, p. 273 et seq.

$$(4) \quad ll' + mm' + nn' = 0.$$

The condition for their being parallel is that

$$(5) \quad l : l' = m : m' = n : n'.$$

Distance Between Two Points:

$$(6) \quad d = \sqrt{(x_1 - x_0)^2 + (y_1 - y_0)^2 + (z_1 - z_0)^2}.$$

Equation of Sphere. Let the centre be at (a, b, c) and the radius be r :

$$(7) \quad (x - a)^2 + (y - b)^2 + (z - c)^2 = r^2.$$

The Plane. Let OP be the perpendicular dropped from the origin on the plane, let $\overline{OP} = p$, and let α, β, γ be the angles OP makes with the axes. Then the equation of the plane is

$$(8) \quad x \cos \alpha + y \cos \beta + z \cos \gamma = p.$$

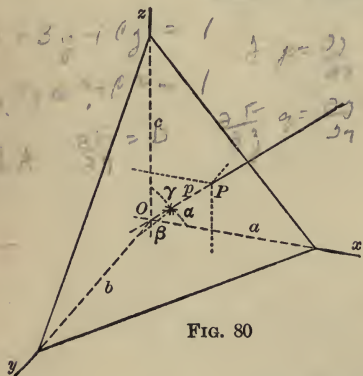

FIG. 80

The equation of a plane whose intercepts on the axes are a, b , and c is:

$$(9) \quad \frac{x}{a} + \frac{y}{b} + \frac{z}{c} = 1.$$

The general equation of the first degree:

$$(10) \quad Ax + By + Cz + D = 0$$

can be thrown into the form (8) as follows:

$$(11) \quad \frac{A}{\Delta}x + \frac{B}{\Delta}y + \frac{C}{\Delta}z = \frac{-D}{\Delta},$$

where $\Delta = (A^2 + B^2 + C^2)^{\frac{1}{2}}$. If D was originally positive, change the signs of all the coefficients, so that D become negative: $-D \geq 0$. Then

$$(12) \quad \cos \alpha = \frac{A}{\Delta}, \quad \cos \beta = \frac{B}{\Delta}, \quad \cos \gamma = \frac{C}{\Delta}, \quad p = \frac{-D}{\Delta}.$$

For most purposes it is sufficient to note that

$$(13) \quad \cos \alpha : \cos \beta : \cos \gamma = A : B : C.$$

The angle between two planes:

$$Ax + By + Cz + D = 0,$$

$$A'x + B'y + C'z + D' = 0,$$

is given by the formula:

$$(14) \quad \cos \theta = \frac{AA' + BB' + CC'}{\Delta \Delta'}.$$

The planes are perpendicular if

$$(15) \quad AA' + BB' + CC' = 0,$$

and conversely. They are parallel if

$$(16) \quad A : A' = B : B' = C : C'.$$

The distance d of the point $P: (x_1, y_1, z_1)$ from the plane (8) is

$$(17) \quad d = \pm (x_1 \cos \alpha + y_1 \cos \beta + z_1 \cos \gamma - p),$$

where the lower sign is to be used if O and P are on the same side of the plane, and the upper sign in case they are on opposite sides.

The Straight Line. A straight line may be determined (a) as the intersection of two planes:

$$(18) \quad \begin{cases} Ax + By + Cz + D = 0, \\ A'x + B'y + C'z + D' = 0; \end{cases}$$

(b) by its direction and one of its points:

$$(19) \quad \frac{x - x_0}{\cos \alpha} = \frac{y - y_0}{\cos \beta} = \frac{z - z_0}{\cos \gamma};$$

or

$$(19 a) \quad \frac{x - x_0}{l} = \frac{y - y_0}{m} = \frac{z - z_0}{n},$$

where $l : m : n = \cos \alpha : \cos \beta : \cos \gamma$;

(c) by two of its points:

$$(20) \quad \frac{x - x_0}{x_1 - x_0} = \frac{y - y_0}{y_1 - y_0} = \frac{z - z_0}{z_1 - z_0}.$$

In the latter case

$$(21) \quad \cos \alpha : \cos \beta : \cos \gamma = x_1 - x_0 : y_1 - y_0 : z_1 - z_0.$$

If (x_0, y_0, z_0) is a point of the line (18), the equations may be expressed in the form (19) as follows:

$$(22) \quad \frac{x - x_0}{\begin{vmatrix} B & C \\ B' & C' \end{vmatrix}} = \frac{y - y_0}{\begin{vmatrix} C & A \\ C' & A' \end{vmatrix}} = \frac{z - z_0}{\begin{vmatrix} A & B \\ A' & B' \end{vmatrix}}.$$

The direction cosines of (18) are thus given by the relations:

$$(23) \quad \cos \alpha : \cos \beta : \cos \gamma = \begin{vmatrix} B & C \\ B' & C' \end{vmatrix} : \begin{vmatrix} C & A \\ C' & A' \end{vmatrix} : \begin{vmatrix} A & B \\ A' & B' \end{vmatrix}.$$

If the line is given as the intersection of two planes perpendicular respectively to the x, y and the x, z planes:*

$$(24) \quad y = px + b, \quad z = qx + c,$$

its equations can be brought into the form (19) as follows:

$$(25) \quad \frac{x - 0}{1} = \frac{y - b}{p} = \frac{z - c}{q}.$$

Hence

$$(26) \quad \left\{ \begin{array}{l} \cos \alpha = \frac{1}{\sqrt{1 + p^2 + q^2}}, \\ \cos \beta = \frac{p}{\sqrt{1 + p^2 + q^2}}, \\ \cos \gamma = \frac{q}{\sqrt{1 + p^2 + q^2}}. \end{array} \right.$$

Line Normal to a Plane. The equations of a straight line passing through any point (x_0, y_0, z_0) of space and perpendicular to the plane (18) are:

$$(27) \quad \frac{x - x_0}{A} = \frac{y - y_0}{B} = \frac{z - z_0}{C}.$$

Plane Normal to a Line. The equation of a plane passing through any point (x_0, y_0, z_0) of space and perpendicular to the line (19 a) is:

$$(28) \quad l(x - x_0) + m(y - y_0) + n(z - z_0) = 0.$$

*The p that figures here has, of course, nothing to do with the former p , the length of the perpendicular.

Variable Plane through a Line. The equation of a variable plane through the line (18) is:

$$(29) \quad (Ax + By + Cz + D) + k(A'x + B'y + C'z + D') = 0,$$

where k may have any value whatever.

Three Planes through a Line. The condition that the three planes

$$Ax + By + Cz + D = 0,$$

$$A'x + B'y + C'z + D' = 0,$$

$$A''x + B''y + C''z + D'' = 0,$$

all intersect in one and the same straight line is that

$$(30) \quad \begin{vmatrix} A & B & C \\ A' & B' & C' \\ A'' & B'' & C'' \end{vmatrix} = 0,$$

and that they have one point in common.

The student should notice that, while one equation determines a plane, it always takes two equations in x, y, z to determine a line.

3. Partial Derivatives. If in the function (1) we hold y fast and differentiate with respect to x , we obtain the *partial derivative* of z with respect to x , denoted by

$$\frac{\partial z}{\partial x} \quad \text{or} \quad f_x(x, y).$$

Similarly, differentiation with respect to y , x being constant, gives

$$\frac{\partial z}{\partial y} \quad \text{or} \quad f_y(x, y),$$

Thus if

$$z = e^{-x} \sin y,$$

$$\frac{\partial z}{\partial x} = -e^{-x} \sin y, \quad \frac{\partial z}{\partial y} = e^{-x} \cos y.$$

EXERCISES

1. Find $\frac{\partial z}{\partial x}$ and $\frac{\partial z}{\partial y}$ in each of the following cases:

$$(a) z = x \log y;$$

$$(b) z = ax^2 + 2bxy + cy^2;$$

$$(c) z = \frac{e^{xy}}{x^2 + y^2};$$

$$(d) x^2 + y^2 + z^2 = \alpha^2.$$

2. Find all the partial derivatives of u , when $u = ax + by + cz$.

3. If $pv = ap_0v_0T$,

where a, p_0, v_0 are constants, find $\frac{\partial v}{\partial T}$.

4. Geometric Interpretation. Geometrically the meaning of the partial derivatives in case there are but two independent variables is as follows. Holding y fast is equivalent to cutting the surface (1) by the plane $y = y_0$. The section is a plane curve:

$$z = f(x, y_0),$$

and $\frac{\partial z}{\partial x}$ is the slope of this curve. Similarly $\frac{\partial z}{\partial y}$ is the slope of the curve

$$z = f(x_0, y).$$

We thus have the slopes of two tangent lines to the surface (1) at the point (x_0, y_0, z_0) , and hence we can readily determine the equation of the tangent plane through this point. For the tangent plane at a point contains all the tangent lines at the point and is determined by any two of them. If, therefore, we write the equation of the tangent plane with undetermined coefficients in the form:

$$z - z_0 = A(x - x_0) + B(y - y_0),$$

we have only to require that the slope of the line in which this plane is cut by the plane $y = y_0$, *i.e.*

$$z - z_0 = A(x - x_0)$$

be $\partial z / \partial x$, formed for the point (x_0, y_0) , — we will denote this quantity by $(\partial z / \partial x)_0$, — and similarly that the slope of the line in which the plane is cut by the plane $x = x_0$:

$$z - z_0 = B(y - y_0),$$

be $(\partial z / \partial y)_0$. Hence

$$A = \left(\frac{\partial z}{\partial x} \right)_0, \quad B = \left(\frac{\partial z}{\partial y} \right)_0,$$

and we obtain as the *equation of the tangent plane*:

$$(31) \quad z - z_0 = \left(\frac{\partial z}{\partial x} \right)_0 (x - x_0) + \left(\frac{\partial z}{\partial y} \right)_0 (y - y_0).$$

From (28) it follows that the equations of the normal line (or simply the *normal*) to the surface (1) at the point P : (x_0, y_0, z_0) are:

$$(32) \quad \frac{x - x_0}{\left(\frac{\partial z}{\partial x} \right)_0} = \frac{y - y_0}{\left(\frac{\partial z}{\partial y} \right)_0} = \frac{z - z_0}{-1}.$$

The direction cosines of the normal are given by the relations:

$$(33) \quad \cos \alpha : \cos \beta : \cos \gamma = \left(\frac{\partial z}{\partial x} \right)_0 : \left(\frac{\partial z}{\partial y} \right)_0 : -1.$$

EXERCISES

Find the equations of the tangent plane and the normal to the following surfaces:

1.
$$z = \tan^{-1} \frac{y}{x}.$$

Ans.
$$y_0 x - x_0 y + (x_0^2 + y_0^2)(z - z_0) = 0;$$

$$\frac{x - x_0}{y_0} = \frac{y - y_0}{-x_0} = \frac{z - z_0}{x_0^2 + y_0^2}.$$

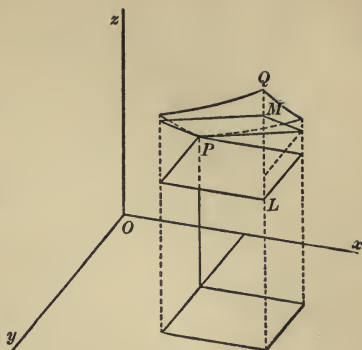

FIG. 81

2. $z = ax^2 + by^2.$

Ans. For the tangent plane: $z = 2ax_0x + 2by_0y - z_0.$

3. $x^2 + y^2 + z^2 = a^2.$

4. Show that the surface

$$z = xy$$

is tangent to the x, y plane at the origin.

5. The sphere: $x^2 + y^2 + z^2 = 14$

and the ellipsoid: $3x^2 + 2y^2 + z^2 = 20$

intersect in the point $(-1, -2, 3)$. Find the angle at which they cut each other there. *Ans.* $23^\circ 33'.$

6. What angle does the tangent plane of the ellipsoid in the preceding question make with the x, y plane? *Ans.* $59^\circ 2'.$

7. At what angle is the surface

$$z = 3xy^2 - 5x^2y - 7x + 3y$$

cut by the axis of x at the origin? *Ans.* $65^\circ 41'.$

5. **Derivatives of Higher Order.** The first partial derivatives of the function

$$u = f(x, y):$$

$$\frac{\partial u}{\partial x} = f_x(x, y), \quad \frac{\partial u}{\partial y} = f_y(x, y),$$

are themselves functions of x and y , and can in turn be differentiated:

$$\frac{\partial^2 u}{\partial x^2} = f_{xx}(x, y) \quad \text{or} \quad f_{x^2}(x, y), \quad \frac{\partial}{\partial y} \left(\frac{\partial u}{\partial x} \right) = \frac{\partial^2 u}{\partial y \partial x} = f_{yx}(x, y), \text{ etc.}$$

It can be shown that the order of differentiation does not matter, provided merely that the derivatives concerned are continuous functions:

(34)

$$\frac{\partial^2 u}{\partial x \partial y} = \frac{\partial^2 u}{\partial y \partial x}.$$

The theorem holds for functions of any number of variables.*

Let us verify the theorem in some special cases.

$$(a) \quad u = e^x \cos y;$$

$$\frac{\partial u}{\partial x} = e^x \cos y, \quad \frac{\partial}{\partial y} \left(\frac{\partial u}{\partial x} \right) = -e^x \sin y;$$

$$\frac{\partial u}{\partial y} = -e^x \sin y, \quad \frac{\partial}{\partial x} \left(\frac{\partial u}{\partial y} \right) = -e^x \sin y.$$

$$(b) \quad u = \frac{x \log z}{y};$$

$$f_x(u) = \frac{\partial u}{\partial x} = \frac{\log z}{y}, \quad \frac{\partial^2 u}{\partial z \partial x} = \frac{1}{yz};$$

$$f_z(u) = \frac{\partial u}{\partial z} = \frac{x}{yz}, \quad \frac{\partial^2 u}{\partial x \partial z} = \frac{1}{yz}.$$

EXERCISES

1. Verify the theorem for the other two pairs of cross derivatives in (b).

2. Verify the theorem in each of the following cases:

$$(a) \quad u = z \sin xy; \quad (b) \quad u = \log(xy^2); \quad (c) \quad u = y^z.$$

3. Prove that

$$\frac{\partial^3 u}{\partial x^2 \partial y} = \frac{\partial^3 u}{\partial y \partial x^2} = \frac{\partial^3 u}{\partial x \partial y \partial x}.$$

4. If

$$u = \log \sqrt{x^2 + y^2},$$

then

$$\frac{\partial^2 u}{\partial x^2} + \frac{\partial^2 u}{\partial y^2} = 0.$$

* The proofs of this theorem formerly given are not rigorous. For a critique of these see Gibson, *Elementary Treatise on the Calculus*, § 93, where a correct proof, due to Schwarz, is to be found; or Goursat-Hedrick, *Mathematical Analysis*, vol. 1, § 11. A simple proof can be given by integration; cf. Whittemore, *Bulletin Amer. Math. Soc.*, ser. 2, vol. 4 (1898), p. 389.

5. If
$$u = \frac{1}{\sqrt{x^2 + y^2 + z^2}},$$

then
$$\frac{\partial^2 u}{\partial x^2} + \frac{\partial^2 u}{\partial y^2} + \frac{\partial^2 u}{\partial z^2} = 0.$$

6. If
$$\frac{\partial u}{\partial x} = \frac{\partial v}{\partial y} \quad \text{and} \quad \frac{\partial u}{\partial y} = -\frac{\partial v}{\partial x},$$

then
$$\frac{\partial^2 u}{\partial x^2} + \frac{\partial^2 u}{\partial y^2} = 0.$$

6. **The Total Differential.** Let us form the increment of the function

$$u = f(x, y):$$

$$\Delta u = f(x_0 + \Delta x, y_0 + \Delta y) - f(x_0, y_0).$$

If we subtract and add the quantity $f(x_0, y_0 + \Delta y)$, we shall have:

$$\begin{aligned} \Delta u &= f(x_0 + \Delta x, y_0 + \Delta y) - f(x_0, y_0 + \Delta y) \\ &\quad + f(x_0, y_0 + \Delta y) - f(x_0, y_0). \end{aligned}$$

Applying the law of the mean to these two differences gives:

$$(35) \quad \Delta u = \Delta x f_x(x_0 + \theta \Delta x, y_0 + \Delta y) + \Delta y f_y(x_0, y_0 + \theta' \Delta y).$$

Now if $f_x(x, y)$ and $f_y(x, y)$ are continuous functions of x, y , $f_x(x_0 + \theta \Delta x, y_0 + \Delta y)$ will approach $f_x(x_0, y_0)$ as its limit when Δx and Δy both approach zero, and hence will differ but slightly from $f_x(x_0, y_0)$ when Δx and Δy are numerically small:

$$f_x(x_0 + \theta \Delta x, y_0 + \Delta y) = f_x(x_0, y_0) + \epsilon,$$

where ϵ is infinitesimal:

$$\lim_{\Delta x \neq 0, \Delta y \neq 0} \epsilon = 0.$$

Similarly, the limit of $f_y(x_0, y_0 + \theta' \Delta y)$ is $f_y(x_0, y_0)$ and

$$f_y(x_0, y_0 + \theta' \Delta y) = f_y(x_0, y_0) + \eta,$$

where η is infinitesimal.

Hence (35) may be written in the form:

$$(36) \quad \Delta u = \frac{\partial u}{\partial x} \Delta x + \frac{\partial u}{\partial y} \Delta y + \epsilon \Delta x + \eta \Delta y,$$

where we have dropped the subscripts and replaced $f_x(x, y)$, $f_y(x, y)$ by the alternative notation.

Formula (36) is analogous to the second formula on p. 92, and so it is natural to describe the linear terms:

$$\frac{\partial u}{\partial x} \Delta x + \frac{\partial u}{\partial y} \Delta y$$

as the *principal part* of Δu . The remaining terms form an infinitesimal of higher order.*

DEFINITION. We define the *total differential* of u as the principal part of Δu :

$$(37) \quad du = \frac{\partial u}{\partial x} \Delta x + \frac{\partial u}{\partial y} \Delta y.$$

Since this definition holds for all functions u , we may in particular set $u = x$. From (37) follows then that

$$(38) \quad dx = \Delta x.$$

Similarly, setting $u = y$, we get:

$$(39) \quad dy = \Delta y.$$

Substituting these values in (37) gives

* If ζ is an infinitesimal depending on several, let us say two, independent variables, α and β , and if we take these variables as the principal infinitesimals, then ζ is said to be an *infinitesimal of higher order* than α and β if

$$\lim_{\alpha \neq 0, \beta \neq 0} \frac{\zeta}{\sqrt{\alpha^2 + \beta^2}} = 0.$$

ζ is said to be of the *same order* if

$$K \leq \frac{\zeta}{\sqrt{\alpha^2 + \beta^2}} \leq G,$$

where K and G are constants, both positive or both negative. Instead of the above ratio we might equally well have used

$$\frac{\zeta}{|\alpha| + |\beta|}.$$

$$(A) \quad du = \frac{\partial u}{\partial x} dx + \frac{\partial u}{\partial y} dy.$$

The definition (37) and the theorems (38) and (39) can be extended to functions of any number of variables. Thus if $u = f(x, y, z)$ we have by definition

$$du = \frac{\partial u}{\partial x} \Delta x + \frac{\partial u}{\partial y} \Delta y + \frac{\partial u}{\partial z} \Delta z,$$

and we conclude as above that

$$du = \frac{\partial u}{\partial x} dx + \frac{\partial u}{\partial y} dy + \frac{\partial u}{\partial z} dz.$$

It is sometimes convenient to use the partial differentials of u obtained by allowing only one of the variables to change:

$$d_x u = \frac{\partial u}{\partial x} \Delta x = \frac{\partial u}{\partial x} dx, \quad \text{etc.}$$

We have then:

$$(40) \quad du = d_x u + d_y u + \dots$$

Geometric Interpretation. In the case of a function of two independent variables:

$$z = f(x, y),$$

the increment and the differential of the function admit a simple geometric interpretation. If we pass a plane through the point $P : (x_0, y_0, z_0)$ parallel to the x, y plane and then draw a line parallel to the z -axis and cutting that plane in the points $x = x_0 + \Delta x$, $y = y_0 + \Delta y$, the segment of this line between the above plane $z = z_0$ and the surface is (see Fig. 81):

$$LQ = f(x_0 + \Delta x, y_0 + \Delta y) - f(x_0, y_0) = \Delta z.$$

The equation of the tangent plane at P is

$$z - z_0 = \left(\frac{\partial z}{\partial x} \right)_0 (x - x_0) + \left(\frac{\partial z}{\partial y} \right)_0 (y - y_0),$$

and the segment of the line between the plane $z = z_0$ and this plane is

$$LM = \left(\frac{\partial z}{\partial x} \right)_0 \Delta x + \left(\frac{\partial z}{\partial y} \right)_0 \Delta y = dz.$$

The difference :

$$\Delta z - dz = MQ = \epsilon \Delta x + \eta \Delta y,$$

is an infinitesimal of higher order than Δx and Δy .

7. Continuation. Change of Variable. In the foregoing paragraph we have assumed that x and y are the independent variables. If each depends on a third variable, t :

$$(41) \quad x = \phi(t), \quad y = \psi(t),$$

then u becomes a function of a single variable, t , and the differential of such a function has already been defined, Chap. V, § 4 :

$$(42) \quad du = D_t u \Delta t = D_t u dt.$$

Also :

$$(43) \quad dx = D_t x dt, \quad dy = D_t y dt.$$

Here $dt = \Delta t$; but dx and dy are not in general equal to Δx and Δy respectively. The question therefore arises: Will the theorem (A) still hold? We proceed to show that it will.

Let Δx and Δy be the increments that x and y receive by virtue of (41) when t has the increment Δt . Then, substituting these values in (36), we get the increment of u . Now divide through by Δt and take the limit of each side:

$$\lim_{\Delta t \neq 0} \left(\frac{\Delta u}{\Delta t} \right) = \frac{\partial u}{\partial x} \lim_{\Delta t \neq 0} \left(\frac{\Delta x}{\Delta t} \right) + \frac{\partial u}{\partial y} \lim_{\Delta t \neq 0} \left(\frac{\Delta y}{\Delta t} \right) + \lim_{\Delta t \neq 0} \left(\epsilon \frac{\Delta x}{\Delta t} + \eta \frac{\Delta y}{\Delta t} \right).$$

The last limit has the value 0, and hence

$$(44) \quad D_t u = \frac{\partial u}{\partial x} D_t x + \frac{\partial u}{\partial y} D_t y,$$

and
$$du = \frac{\partial u}{\partial x} dx + \frac{\partial u}{\partial y} dy, \quad \text{q. e. d.}$$

Thus (A) is seen to hold even when t is the independent variable.

Finally, let x and y depend on r and s :

$$(45) \quad x = \phi(r, s), \quad y = \psi(r, s).$$

If we hold s fast and allow r alone to vary, we have the case just treated, the independent variable now being r instead of t . Hence (44) is still valid, the derivatives with respect to r now being partial :

$$(B) \quad \frac{\partial u}{\partial r} = \frac{\partial u}{\partial x} \frac{\partial x}{\partial r} + \frac{\partial u}{\partial y} \frac{\partial y}{\partial r}.$$

In like manner :

$$\frac{\partial u}{\partial s} = \frac{\partial u}{\partial x} \frac{\partial x}{\partial s} + \frac{\partial u}{\partial y} \frac{\partial y}{\partial s}.$$

Let us state this result in the form of a theorem. It is applicable to functions of any number of variables.

THEOREM 1. *If*

$$u = f(x, y, z, \dots),$$

and if each of the arguments x, y, z, \dots is made to depend on r, s, \dots :

$$x = \phi(r, s, \dots), \quad y = \psi(r, s, \dots), \quad z = \omega(r, s, \dots),$$

then, if all the derivatives involved are continuous :

$$(B) \quad \frac{\partial u}{\partial r} = \frac{\partial u}{\partial x} \frac{\partial x}{\partial r} + \frac{\partial u}{\partial y} \frac{\partial y}{\partial r} + \frac{\partial u}{\partial z} \frac{\partial z}{\partial r} + \dots,$$

with similar formulas for $\frac{\partial u}{\partial s}$, etc., obtained from (B) by replacing r by s , etc.

The number of variables in each class, (x, y, z, \dots) and (r, s, \dots) , is arbitrary. If, in particular, there is only one variable, x , in the first class, but several in the second, we have

$$\frac{\partial u}{\partial r} = \frac{du}{dx} \frac{\partial x}{\partial r};$$

and if there is only one variable, t , in the second class, but several in the first, then we have formula (44):

$$\frac{du}{dt} = \frac{\partial u}{\partial x} \frac{dx}{dt} + \frac{\partial u}{\partial y} \frac{dy}{dt} + \frac{\partial u}{\partial z} \frac{dz}{dt} + \dots$$

Example. Let

$$u = e^{xy},$$

$$x = \log \sqrt{r^2 + s^2}, \quad y = \tan^{-1} \frac{s}{r}.$$

Then
$$\frac{\partial u}{\partial x} = ye^{xy}, \quad \frac{\partial u}{\partial y} = xe^{xy},$$

$$\frac{\partial x}{\partial r} = \frac{r}{r^2 + s^2}, \quad \frac{\partial y}{\partial r} = \frac{-s}{r^2 + s^2},$$

and hence

$$\frac{\partial u}{\partial r} = \frac{ry - sx}{r^2 + s^2} e^{xy},$$

from which expression x and y can be eliminated if desired.

For Prob.

EXERCISES

✓ 1. If

$$u = x^2 - y^2$$

and

$$\begin{cases} x = 2r - 3s + 7, \\ y = -r + 8s - 9, \end{cases}$$

find $\frac{\partial u}{\partial r}$.

Ans. $\frac{\partial u}{\partial r} = 4x + 2y.$

✓ 2. In the preceding question, find $\frac{\partial u}{\partial s}$.

✓ 3. If

$$u = xy^z$$

and

$$x = a \cos \theta, \quad y = a \sin \theta, \quad z = b\theta,$$

find $\frac{du}{d\theta}$.

✓ 4. If

$$u = \frac{x+y}{1-xy}$$

and

$$x = \tan(2r - s^2), \quad y = \cot(r^2 s),$$

find $\frac{\partial u}{\partial r}$ and $\frac{\partial u}{\partial s}$.

✓ 5. If

$$u = f(x, y, z)$$

and

$$\left. \begin{aligned} x &= ax' + by' + cz', \\ y &= a'x' + b'y' + c'z', \\ z &= a''x' + b''y' + c''z', \end{aligned} \right\}$$

show that
$$\frac{\partial u}{\partial x'} = a \frac{\partial u}{\partial x} + a' \frac{\partial u}{\partial y} + a'' \frac{\partial u}{\partial z},$$

and find $\frac{\partial u}{\partial y'}$ and $\frac{\partial u}{\partial z'}$.

6. If $x = r \cos \phi, \quad y = r \sin \phi,$

show that
$$\left(\frac{\partial u}{\partial x}\right)^2 + \left(\frac{\partial u}{\partial y}\right)^2 = \left(\frac{\partial u}{\partial r}\right)^2 + \frac{1}{r^2} \left(\frac{\partial u}{\partial \phi}\right)^2.$$

Suggestion. Compute first $\frac{\partial u}{\partial r}$ and $\frac{\partial u}{\partial \phi}$ in terms of $\frac{\partial u}{\partial x}$ and $\frac{\partial u}{\partial y}$.

8. Conclusion. We are now in a position to show that the theorem (A) is true no matter what the independent variables are. If

$$u = f(x, y)$$

and $x = \phi(r, s), \quad y = \psi(r, s),$

then, by the definition (37),

$$du = \frac{\partial u}{\partial r} \Delta r + \frac{\partial u}{\partial s} \Delta s.$$

Also

$$dx = \frac{\partial x}{\partial r} \Delta r + \frac{\partial x}{\partial s} \Delta s,$$

$$dy = \frac{\partial y}{\partial r} \Delta r + \frac{\partial y}{\partial s} \Delta s.$$

Hence

$$\begin{aligned} \frac{\partial u}{\partial x} dx + \frac{\partial u}{\partial y} dy &= \\ \left(\frac{\partial u}{\partial x} \frac{\partial x}{\partial r} + \frac{\partial u}{\partial y} \frac{\partial y}{\partial r}\right) \Delta r + \left(\frac{\partial u}{\partial x} \frac{\partial x}{\partial s} + \frac{\partial u}{\partial y} \frac{\partial y}{\partial s}\right) \Delta s &= \\ = \frac{\partial u}{\partial r} \Delta r + \frac{\partial u}{\partial s} \Delta s = du, & \end{aligned}$$

q. e. d.

We will state the result as

THEOREM 2. *If*

$$u = f(x, y, z, \dots),$$

and if each of the arguments x, y, z, \dots is made to depend on r, s, \dots :

$$x = \phi(r, s, \dots), \quad y = \psi(r, s, \dots), \quad z = \omega(r, s, \dots),$$

then, if all the first partial derivatives are continuous, we shall have:

$$du = \frac{\partial u}{\partial x} dx + \frac{\partial u}{\partial y} dy + \frac{\partial u}{\partial z} dz + \dots,$$

no matter whether the independent variables are x, y, z, \dots or r, s, \dots .

The number of variables in each class, (x, y, z, \dots) and (r, s, \dots) , is arbitrary.

It is readily shown that the general theorems relating to the differentials of functions of a single variable:

$$d(cu) = cdu,$$

$$d(u + v) = du + dv,$$

$$d(uv) = u dv + v du,$$

$$d\left(\frac{u}{v}\right) = \frac{v du - u dv}{v^2},$$

hold for functions of several variables. Moreover, the differential of a constant, considered as a function of several variables, is 0:

$$dc = 0.$$

Example. Let us work the example of § 7 by means of the above theorem.

$$du = ye^{xy} dx + xe^{xy} dy,$$

$$dx = \frac{r}{r^2 + s^2} dr + \frac{s}{r^2 + s^2} ds,$$

$$dy = \frac{-s}{r^2 + s^2} dr + \frac{r}{r^2 + s^2} ds.$$

Hence

$$\begin{aligned} du &= \frac{ry - sx}{r^2 + s^2} e^{xy} dr + \frac{sy + rx}{r^2 + s^2} e^{xy} ds \\ &= \frac{\partial u}{\partial r} dr + \frac{\partial u}{\partial s} ds. \end{aligned}$$

Now $dr = \Delta r$ and $ds = \Delta s$ are independent variables, and consequently we can equate their coefficients on the two sides of the last equation: *

$$\frac{\partial u}{\partial r} = \frac{ry - sx}{r^2 + s^2} e^{xy}, \quad \frac{\partial u}{\partial s} = \frac{sy + rx}{r^2 + s^2} e^{xy}.$$

EXERCISES

1. Work the first four exercises at the end of § 7 by the method just explained.

2. If $u = f(x + a, y + b),$

show that $\frac{\partial u}{\partial x} = \frac{\partial u}{\partial a},$ and $\frac{\partial u}{\partial y} = \frac{\partial u}{\partial b}.$

3. If $u = f(x)$ and $x = 3r + 2s + 7t,$

show that $\frac{\partial u}{\partial s} = 2 \frac{du}{dx}.$

9. Euler's Theorem for Homogeneous Functions. A function u is said to be *homogeneous* if, when each of the arguments is multiplied by one and the same quantity, the function is merely multiplied by a power of this quantity. For definiteness we will assume three arguments:

$$u = f(x, y, z),$$

$$(46) \quad f(\lambda x, \lambda y, \lambda z) = \lambda^n f(x, y, z).$$

* The reasoning here, given at greater length, is as follows. Since dr and ds are both arbitrary, we may set $ds = 0, dr \neq 0,$ and then cancel $dr.$ Thus the coefficients of dr on both sides of the equation are seen to be equal. Similarly, setting $dr = 0, ds \neq 0,$ we infer the equality of the coefficients of $ds.$

The exponent n of λ is called the *order* of the function.

Thus the functions

$$u = ax^2 + bxy + cy^2, \quad u = \frac{1}{2} \log(x^2 + y^2) - \log x,$$

$$u = \frac{ax + by}{cx + dy}, \quad u = \frac{z}{\sqrt[3]{x^2 + y^2}}, \quad u = z \tan^{-1} \frac{y}{x},$$

are homogeneous of order $2, 0, 0, \frac{1}{3}, 1$, respectively.

If in particular we set $\lambda = \frac{1}{x}$, we have

$$f\left(1, \frac{y}{x}, \frac{z}{x}\right) = \left(\frac{1}{x}\right)^n f(x, y, z),$$

$$(47) \quad f(x, y, z) = x^n f\left(1, \frac{y}{x}, \frac{z}{x}\right).$$

Let the student verify this last formula for each of the functions above given.

EULER'S THEOREM. *If u is homogeneous and has continuous first partial derivatives, then*

$$(C) \quad x \frac{\partial u}{\partial x} + y \frac{\partial u}{\partial y} + z \frac{\partial u}{\partial z} = nu.$$

We have by (46)

$$(48) \quad f(x', y', z') = \lambda^n f(x, y, z), \\ x' = \lambda x, \quad y' = \lambda y, \quad z' = \lambda z.$$

Differentiate (48) partially with respect to λ :

$$(49) \quad f_x(x', y', z')x + f_y(x', y', z')y + f_z(x', y', z')z = n\lambda^{n-1}f(x, y, z),$$

where $f_x(x', y', z')$ denotes as usual the partial derivative of $f(x, y, z)$ with respect to x , the arguments being subsequently replaced by x', y', z' respectively. If we now put $\lambda = 1$, (49) assumes the form (C), and the theorem is proven.

We have stated and proved the theorem for a function of three variables. But theorem and proof hold for a function of any number of variables.

EXERCISE

Verify Euler's Theorem for each of the above examples.

10. Differentiation of Implicit Functions. Let y be defined implicitly as a function of x by the equation (cf. Chap. II, § 9):

$$(50) \quad F(x, y) = 0.$$

To differentiate y we begin by setting

$$u = F(x, y)$$

and forming the total differential of u :

$$du = \frac{\partial F}{\partial x} dx + \frac{\partial F}{\partial y} dy.$$

This relation is true, no matter what the independent variables are, § 8, Theorem 2. We may, therefore, in particular choose y so that the equation (50) is satisfied. Then $du = 0$, and we have:

$$(51) \quad \frac{\partial F}{\partial x} + \frac{\partial F}{\partial y} \frac{dy}{dx} = 0 \quad \text{or} \quad \frac{dy}{dx} = -\frac{\frac{\partial F}{\partial x}}{\frac{\partial F}{\partial y}}.$$

In like manner, if z is defined by the equation:

$$(52) \quad F(x, y, z) = 0,$$

we can differentiate z partially by setting

$$u = F(x, y, z)$$

and taking the total differential of each side:

$$du = \frac{\partial F}{\partial x} dx + \frac{\partial F}{\partial y} dy + \frac{\partial F}{\partial z} dz.$$

This equation is true, no matter what the independent variables are.

If in particular z be so chosen that the equation (52) is satisfied, then $du = 0$, and

$$\frac{\partial F}{\partial x} dx + \frac{\partial F}{\partial y} dy + \frac{\partial F}{\partial z} dz = 0.$$

But dz now has the value:

$$dz = \frac{\partial z}{\partial x} dx + \frac{\partial z}{\partial y} dy.$$

Hence, eliminating dz , we have

$$\left(\frac{\partial F}{\partial x} + \frac{\partial F}{\partial z} \frac{\partial z}{\partial x}\right) dx + \left(\frac{\partial F}{\partial y} + \frac{\partial F}{\partial z} \frac{\partial z}{\partial y}\right) dy = 0.$$

Here $dx = \Delta x$ and $dy = \Delta y$ are independent variables. We may, therefore, set $dy = 0$, $dx \neq 0$, and divide through by dx :

$$(53) \quad \frac{\partial F}{\partial x} + \frac{\partial F}{\partial z} \frac{\partial z}{\partial x} = 0, \quad \frac{\partial z}{\partial x} = -\frac{\frac{\partial F}{\partial x}}{\frac{\partial F}{\partial z}}.$$

A similar equation holds for $\partial z / \partial y$, x being replaced throughout in (53) by y .

The student should notice carefully what the independent variables are in each differentiation. Thus $\partial F / \partial x$ is the derivative of a function of *three* independent variables, x, y, z , and the values of these variables are not in general such as to satisfy the equation (52). At this stage of the work (52) is irrelevant, does not exist for us, has not as yet come into play. The same is true of $\partial F / \partial y$ and $\partial F / \partial z$. When we come to $\partial z / \partial x$, however, *this* z is a *function* of the *two* independent variables, x and y , — and such a function that (52) is satisfied.

The generalization to a function u of any number of variables is now obvious:

$$F(u, x, y, z, \dots) = 0,$$

$$(54) \quad \frac{\partial F}{\partial u} \frac{\partial u}{\partial x} + \frac{\partial F}{\partial x} = 0, \quad \frac{\partial u}{\partial x} = -\frac{\frac{\partial F}{\partial x}}{\frac{\partial F}{\partial u}},$$

etc.

Example. Differentiate z partially, where

$$\frac{x^2}{a^2} + \frac{y^2}{b^2} + \frac{z^2}{c^2} = 1.$$

Here

$$F(x, y, z) = \frac{x^2}{a^2} + \frac{y^2}{b^2} + \frac{z^2}{c^2} - 1,$$

and we have:

$$\begin{aligned} \frac{2x}{a^2} + \frac{2z}{c^2} \frac{\partial z}{\partial x} &= 0, & \frac{\partial z}{\partial x} &= -\frac{c^2 x}{a^2 z}; \\ \frac{2y}{b^2} + \frac{2z}{c^2} \frac{\partial z}{\partial y} &= 0, & \frac{\partial z}{\partial y} &= -\frac{c^2 y}{b^2 z}. \end{aligned}$$

Several Implicit Functions. We may have two implicit functions, u and v , of any number of variables, x, y, \dots , defined implicitly by two equations:

$$(55) \quad \begin{cases} F(u, v, x, y, \dots) = 0, \\ \Phi(u, v, x, y, \dots) = 0. \end{cases}$$

For definiteness, let the number of variables x, y, \dots be two. Setting

$$U = F(u, v, x, y), \quad V = \Phi(u, v, x, y),$$

and taking differentials, we have:

$$(56) \quad \begin{cases} dU = \frac{\partial F}{\partial u} du + \frac{\partial F}{\partial v} dv + \frac{\partial F}{\partial x} dx + \frac{\partial F}{\partial y} dy, \\ dV = \frac{\partial \Phi}{\partial u} du + \frac{\partial \Phi}{\partial v} dv + \frac{\partial \Phi}{\partial x} dx + \frac{\partial \Phi}{\partial y} dy, \end{cases}$$

no matter what the independent variables are. If we now require that u and v be so determined that the equations (55) be satisfied, we get: $dU = 0, dV = 0$; and furthermore:

$$du = \frac{\partial u}{\partial x} dx + \frac{\partial u}{\partial y} dy,$$

$$dv = \frac{\partial v}{\partial x} dx + \frac{\partial v}{\partial y} dy.$$

Substituting these values of du and dv in the right-hand sides

of (56), we see that the coefficients of dx and dy are equal to 0, and hence we get the two equations :

$$\frac{\partial F}{\partial u} \frac{\partial u}{\partial x} + \frac{\partial F}{\partial v} \frac{\partial v}{\partial x} + \frac{\partial F}{\partial x} = 0, \quad \frac{\partial \Phi}{\partial u} \frac{\partial u}{\partial x} + \frac{\partial \Phi}{\partial v} \frac{\partial v}{\partial x} + \frac{\partial \Phi}{\partial x} = 0,$$

$$\frac{\partial F}{\partial u} \frac{\partial u}{\partial y} + \frac{\partial F}{\partial v} \frac{\partial v}{\partial y} + \frac{\partial F}{\partial y} = 0, \quad \frac{\partial \Phi}{\partial u} \frac{\partial u}{\partial y} + \frac{\partial \Phi}{\partial v} \frac{\partial v}{\partial y} + \frac{\partial \Phi}{\partial y} = 0,$$

and two similar equations, in which F is replaced by Φ . These latter equations the student should write out for himself. From the first and third of these four equations we can solve for $\partial u/\partial x$ and $\partial v/\partial x$, and from the second and fourth, for $\partial u/\partial y$ and $\partial v/\partial y$. Thus

$$(57) \quad \frac{\partial u}{\partial x} = - \frac{\begin{vmatrix} F_x & F_v \\ \Phi_x & \Phi_v \end{vmatrix}}{\begin{vmatrix} F_u & F_v \\ \Phi_u & \Phi_v \end{vmatrix}},$$

with similar formulas for $\partial v/\partial x$, $\partial u/\partial y$, $\partial v/\partial y$. The student should also write these out clearly and neatly.

The generalization is now obvious. Thus if

$$(58) \quad \begin{cases} F(u, v, w, x, y, \dots) = 0, \\ \Phi(u, v, w, x, y, \dots) = 0, \\ \Psi(u, v, w, x, y, \dots) = 0, \end{cases}$$

we shall have

$$(59) \quad \frac{\partial u}{\partial x} = - \frac{\begin{vmatrix} F_x & F_v & F_w \\ \Phi_x & \Phi_v & \Phi_w \\ \Psi_x & \Psi_v & \Psi_w \end{vmatrix}}{\begin{vmatrix} F_u & F_v & F_w \\ \Phi_u & \Phi_v & \Phi_w \\ \Psi_u & \Psi_v & \Psi_w \end{vmatrix}}.$$

The determinant that appears in the denominators :

$$(60) \quad \begin{vmatrix} \frac{\partial F}{\partial u} & \frac{\partial F}{\partial v} \\ \frac{\partial \Phi}{\partial u} & \frac{\partial \Phi}{\partial v} \\ \frac{\partial \Psi}{\partial u} & \frac{\partial \Psi}{\partial v} \end{vmatrix}, \quad \begin{vmatrix} \frac{\partial F}{\partial u} & \frac{\partial F}{\partial v} & \frac{\partial F}{\partial w} \\ \frac{\partial \Phi}{\partial u} & \frac{\partial \Phi}{\partial v} & \frac{\partial \Phi}{\partial w} \\ \frac{\partial \Psi}{\partial u} & \frac{\partial \Psi}{\partial v} & \frac{\partial \Psi}{\partial w} \end{vmatrix},$$

is called the *Jacobian* of the functions F, Φ , or F, Φ, Ψ . In the foregoing it has been tacitly assumed that all the partial derivatives are continuous and that the Jacobian does not vanish.

11. A Question of Notation. *Problem.* Suppose

$$u = f(x, y), \quad y = \phi(x, z),$$

to find $\frac{\partial u}{\partial x}$.

Before beginning a partial differentiation the first question which we must ask ourselves is: *What are the independent variables?* Hitherto the notation has always been such as to suggest readily what the independent variables are. In the present case they may be:

(a) x and y ; or (b) x and z ; or (c) y and z .

We can indicate which case is meant by writing the independent variables as subscripts, thus:

$$(a) \quad \frac{\partial u_{xy}}{\partial x}; \quad (b) \quad \frac{\partial u_{xz}}{\partial x}.$$

In case (c) $\frac{\partial u}{\partial x}$ has no meaning.

Another notation sometimes employed is to mark the variable or variables that are held fast, thus:

$$(a) \quad \left. \frac{\partial u}{\partial x} \right]_y; \quad (b) \quad \left. \frac{\partial u}{\partial x} \right]_z.$$

Let the student compute $\frac{\partial u}{\partial x}$ in cases (a) and (b).

12. Small Errors. In the case of functions of a single variable we have seen that the linear term in the expansion of Taylor's Theorem:

$$f(x) = f(x_0) + f'(x_0)(x - x_0) + \dots,$$

can frequently be used to express with sufficient accuracy the effect of a small error of observation on the final result, cf.

Infinite Series, § 27. This term, $f'(x_0)(x - x_0)$, is precisely the differential of the function, df , for $x = x_0$.

The differential of a function of several variables can be used for a similar purpose. If x, y, \dots are the observed quantities and u the magnitude to be computed, then the precise error in u due to errors of observation $\Delta x = dx, \Delta y = dy$, etc. is Δu . But

$$du = \frac{\partial u}{\partial x} dx + \frac{\partial u}{\partial y} dy + \dots$$

will frequently differ from Δu by a quantity so small that either is as accurate as the observations will warrant,—and du is more easily computed.

Example. The period of a simple pendulum is

$$T = 2\pi\sqrt{\frac{l}{g}}$$

To find the error caused by errors in measuring l and g , or in the variation of l due to temperature and of g due to the location on the earth's surface.

Here
$$dT = \frac{\pi}{\sqrt{lg}} dl - \frac{\pi}{g} \sqrt{\frac{l}{g}} dg$$

or

$$\frac{dT}{T} = \frac{1}{2} \frac{dl}{l} - \frac{1}{2} \frac{dg}{g},$$

and hence a small positive error of k per cent in observing l will increase the computed time by $\frac{1}{2}k$ per cent, and a small positive error of k' per cent in the value of g will decrease the computed time by $\frac{1}{2}k'$ per cent.

EXERCISES

1. A side c of a triangle is determined in terms of the other two sides and the included angle by means of the formula:

$$c^2 = a^2 + b^2 - 2ab \cos \omega.$$

Find approximately the error in c due to slight errors in measuring a , b , and ω .

Ans. The percentage error is given by the formula:

$$\frac{dc}{c} = \frac{(a - b \cos \omega) da + (b - a \cos \omega) db + ab \sin \omega d\omega}{a^2 + b^2 - 2ab \cos \omega}.$$

2. Find approximately the error in the computed area of the triangle in the preceding question.

3. The acceleration of gravity as determined by an Atwood's machine is given by the formula:

$$g = \frac{2s}{t^2}.$$

Find approximately the error due to small errors in observing s and t .

4. Describe an experiment you have performed to determine the focal length of a lens, or the horizontal component of the earth's magnetic force; recall the relative degrees of accuracy you attained in the successive observations, and discuss the effects of the errors of observation on the final result.

13. Directional Derivatives. Let a function

$$u = f(x, y)$$

be given at each point of a region S of the x, y plane and let a curve C be given passing through a point $P: (x_0, y_0)$ of the region. Let P' be a second point of C and form the quotient:

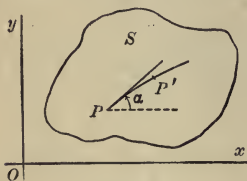

FIG. 82

$$\frac{u_{P'} - u_P}{\overline{PP'}}.$$

The limit of this quotient, when P' approaches P , is defined as the *directional derivative* of u along the curve C .

We set $u_{P'} - u_P = \Delta u$, $\overline{PP'} = \Delta \xi$ and write

$$\lim_{\Delta \xi \rightarrow 0} \frac{\Delta u}{\Delta \xi} = \frac{\partial u}{\partial \xi}.$$

If, in particular, C is a ray parallel to the axis of x and having the same sense, the directional derivative has the value of the partial derivative, $\frac{\partial u}{\partial x}$; if the ray has the opposite sense, the directional derivative is equal to $-\frac{\partial u}{\partial x}$. A similar remark applies to the axis of y .

To compute the directional derivative in the general case we make use of (36) or (37); hence

$$\lim_{\Delta\xi \neq 0} \frac{\Delta u}{\Delta\xi} = \frac{\partial u}{\partial x} \left(\lim_{\Delta\xi \neq 0} \frac{\Delta x}{\Delta\xi} \right) + \frac{\partial u}{\partial y} \left(\lim_{\Delta\xi \neq 0} \frac{\Delta y}{\Delta\xi} \right),$$

or

$$(61) \quad \frac{\partial u}{\partial \xi} = \frac{\partial u}{\partial x} \cos \alpha + \frac{\partial u}{\partial y} \sin \alpha.$$

The extension of the definition to space of three dimensions is immediate. We have:

$$(62) \quad \frac{\partial u}{\partial \xi} = \frac{\partial u}{\partial x} \cos \alpha + \frac{\partial u}{\partial y} \cos \beta + \frac{\partial u}{\partial z} \cos \gamma,$$

where α, β, γ are the angles that C makes at P with the axes.

EXERCISES

1. If a normal be drawn to a curve at any point P and if r denote the distance of a variable point of the plane from a fixed point O ; γ , the angle between PO and the direction of the normal, show that

$$(63) \quad \frac{\partial r}{\partial n} = -\cos \gamma.$$

2. Explain the meaning of $\frac{\partial n}{\partial r}$ and show that

$$(64) \quad \frac{\partial n}{\partial r} = \frac{\partial r}{\partial n}.$$

14. **Exact Differentials.** If in the expression

$$(65) \quad P dx + Q dy$$

P and Q are functions of x and y subject to no restriction ex-

cept that, along with whatever derivatives we wish to use, they be continuous, there may or may not be a function $u = f(x, y)$ whose total differential:

$$du = \frac{\partial u}{\partial x} dx + \frac{\partial u}{\partial y} dy$$

coincides with (65). If there is such a function, then

$$\frac{\partial u}{\partial x} = P, \quad \frac{\partial u}{\partial y} = Q.$$

Now since

$$\frac{\partial}{\partial y} \left(\frac{\partial u}{\partial x} \right) = \frac{\partial}{\partial x} \left(\frac{\partial u}{\partial y} \right),$$

we see that P and Q are subject to the restriction:

$$(66) \quad \frac{\partial P}{\partial y} = \frac{\partial Q}{\partial x}.$$

It can be shown that conversely, when P and Q do satisfy (66), there always does exist a function u , of which (65) is the total differential.* In this case the expression (65) is said to be an *exact differential*.

Example. Consider the expression:

$$(2ax + by + l) dx + (bx + 2cy + m) dy.$$

Here

$$\frac{\partial P}{\partial y} = b, \quad \frac{\partial Q}{\partial x} = b,$$

and hence we have an exact differential before us. To integrate it, begin with

$$\frac{\partial u}{\partial x} = P = 2ax + by + l,$$

and integrate each side with respect to x , regarding y as constant:

$$u = ax^2 + bxy + lx + \phi(y),$$

the constant of integration depending, of course, on y . Now differentiate this expression for u with respect to y :

* Cf. Goursat-Hedrick, *Mathematical Analysis*, vol. 1, §§ 151, 152.

$$\frac{\partial u}{\partial y} = bx + \phi'(y).$$

Comparing this last expression with

$$Q = bx + 2cy + m,$$

we see that

$$\phi'(y) = 2cy + m,$$

$$\phi(y) = cy^2 + my + C.$$

Hence $u = ax^2 + bxy + cy^2 + lx + my + C.$

If we have three independent variables and the expression

$$P dx + Q dy + R dz,$$

the necessary and sufficient condition that it be an exact differential is that

$$(67) \quad \frac{\partial P}{\partial y} = \frac{\partial Q}{\partial x}, \quad \frac{\partial Q}{\partial z} = \frac{\partial R}{\partial y}, \quad \frac{\partial R}{\partial x} = \frac{\partial P}{\partial z}.$$

It is assumed that the partial derivatives are continuous.

EXERCISES

Determine which of the following expressions are exact differentials and integrate such as are :

- $\left(e^x \cos y - \frac{3}{\sqrt{1-x^2}} \right) dx - (e^x \sin y + 7 \sec^2 y) dy.$

- $(x + y) dx + (x - y) dy.$

- $yz e^{xyz} dx + zx e^{xyz} dy + xy e^{xyz} dz.$

EXERCISES

1. If $pv^{1.41} = C$, find $\frac{dv}{dp}$.

2. If $u = \frac{\cos y}{x}$,

$x = r^2 - s$, $y = e^s$,

find $\frac{\partial u}{\partial r}$.

3. If $u = e^{x \sin v} + x \log(x + y)$,

$x = pqr$, $y = r \sin^{-1}(qr)$;

find $\frac{\partial u}{\partial q}$.

4. If $u = 2xy$

and $2x + 3y + 5z = 1$,

explain all the meanings which $\frac{\partial u}{\partial x}$ may have, and evaluate this derivative in each case.

5. If $\begin{cases} u^5 + v^5 + x^5 = 3y, \\ u^3 + v^3 + y^3 = -3x, \end{cases}$

find $\frac{\partial u}{\partial x}$.

6. If $V = 2uv$

and $\begin{cases} u^5 + v^5 + x^5 = 3y, \\ u^3 + v^3 + y^3 = -3x, \end{cases}$

find $\frac{\partial V}{\partial x}$.

7. If $\begin{cases} ue^v + vx = y \sin u, \\ u \cos u = x^2 + y^2, \end{cases}$

find $\frac{\partial v}{\partial y}$.

8. From the equations

$$x = f(u, v), \quad y = \phi(u, v)$$

it follows that

$$1 = \frac{\partial x}{\partial u} \frac{\partial u}{\partial x} + \frac{\partial x}{\partial v} \frac{\partial v}{\partial x},$$

$$0 = \frac{\partial y}{\partial u} \frac{\partial u}{\partial x} + \frac{\partial y}{\partial v} \frac{\partial v}{\partial x}.$$

Explain the meaning of each of the partial derivatives. Compute $\frac{\partial u}{\partial x}$ and $\frac{\partial u}{\partial y}$.

9. If
$$\begin{cases} x = u + uv^2, \\ y = v - uv^2, \end{cases}$$
 find $\frac{\partial u}{\partial x}$.

10. If $u = x^2 + y^2 + z^2$ and $z = xyt$, explain all the meanings of $\frac{\partial u}{\partial x}$.

11. If
$$\begin{cases} z = f(x, y), \\ \phi(x, y) = 0, \end{cases}$$

show that
$$\frac{dz}{dx} = \frac{\frac{\partial z}{\partial x} \frac{\partial \phi}{\partial y} - \frac{\partial z}{\partial y} \frac{\partial \phi}{\partial x}}{\frac{\partial \phi}{\partial y}}.$$

12. If $u = f(x + \alpha t, y + \beta t),$

show that
$$\frac{\partial u}{\partial t} = \alpha \frac{\partial u}{\partial x} + \beta \frac{\partial u}{\partial y},$$

$$\frac{\partial^2 u}{\partial t^2} = \alpha^2 \frac{\partial^2 u}{\partial x^2} + 2\alpha\beta \frac{\partial^2 u}{\partial x \partial y} + \beta^2 \frac{\partial^2 u}{\partial y^2},$$

and obtain the general formula for $\frac{\partial^n u}{\partial t^n}$.

13. If $u = f(y + ax) + \phi(y - ax),$

show that

$$\frac{\partial^2 u}{\partial x^2} = a^2 \frac{\partial^2 u}{\partial y^2}.$$

14. If

$$u = f\left(\frac{y}{x}\right),$$

show that

$$x \frac{\partial u}{\partial x} + y \frac{\partial u}{\partial y} = 0.$$

15. If

$$u = f(x + u, y - u),$$

find $\frac{\partial u}{\partial x}.$

16. If

$$u = f(xu, y),$$

find $\frac{\partial u}{\partial x}.$

17. Use the method of differentials to find $\frac{\partial u}{\partial x}, \frac{\partial u}{\partial y}$ and $\frac{\partial u}{\partial t},$ in terms of $f_{\xi}(\xi, \eta), f_{\eta}(\xi, \eta),$ if

$$u = f(x + ut, y - ut).$$

18. If u is a function merely of the differences of the arguments x_1, x_2, \dots, x_n show that

$$\frac{\partial u}{\partial x_1} + \frac{\partial u}{\partial x_2} + \dots + \frac{\partial u}{\partial x_n} = 0.$$

19. If u and v are two functions of x and y satisfying the relations:

$$\frac{\partial u}{\partial x} = \frac{\partial v}{\partial y}, \quad \frac{\partial u}{\partial y} = -\frac{\partial v}{\partial x},$$

show that, on introducing polar coordinates:

$$x = r \cos \phi, \quad y = r \sin \phi,$$

we have

$$\frac{\partial u}{\partial r} = \frac{1}{r} \frac{\partial v}{\partial \phi}, \quad \frac{1}{r} \frac{\partial u}{\partial \phi} = -\frac{\partial v}{\partial r}.$$

20. If

$$f(x, y) = 0 \quad \text{and} \quad \phi(x, z) = 0,$$

show that

$$\frac{\partial \phi}{\partial x} \frac{\partial f}{\partial y} \frac{dy}{dz} = \frac{\partial f}{\partial x} \frac{\partial \phi}{\partial z}.$$

21. If

$$\phi(p, v, t) = 0,$$

show that

$$\frac{\partial p}{\partial t} \frac{\partial t}{\partial v} \frac{\partial v}{\partial p} = -1.$$

Explain the meaning of each of the partial derivatives.

22. Under the hypotheses of question 19, show that

$$\frac{\partial^2 u}{\partial r^2} + \frac{1}{r} \frac{\partial u}{\partial r} + \frac{1}{r^2} \frac{\partial^2 u}{\partial \phi^2} = 0.$$

23. If $u = f(x, y)$ is homogeneous of order n , show that

$$x^2 \frac{\partial^2 u}{\partial x^2} + 2xy \frac{\partial^2 u}{\partial x \partial y} + y^2 \frac{\partial^2 u}{\partial y^2} = n(n-1)u.$$

24. If u is a function of x, y, z and x, y, z are connected by a single relation, is it true that

$$\frac{\partial u_{xy}}{\partial y} = \frac{\partial u_{xz}}{\partial z} \frac{\partial z_{xy}}{\partial y} ?$$

25. If

$$dU = \theta dS - p dv$$

is an exact differential, and if S and v can be expressed as functions of the independent variables θ, p , show that

$$\frac{\partial \theta}{\partial v} = -\frac{\partial p}{\partial S}, \quad \frac{\partial S}{\partial p} = -\frac{\partial v}{\partial \theta}.$$

State what the independent variables are in each differentiation.

CHAPTER XV

APPLICATIONS TO THE GEOMETRY OF SPACE

1. Tangent Plane and Normal Line to a Surface. We have already obtained the equation of the tangent plane to the surface

$$(1) \quad z = f(x, y)$$

at the point (x_0, y_0, z_0) in Chap. XIV, § 4:

$$(2) \quad z - z_0 = \left(\frac{\partial z}{\partial x}\right)_0 (x - x_0) + \left(\frac{\partial z}{\partial y}\right)_0 (y - y_0).$$

Also of the normal:

$$(3) \quad \frac{x - x_0}{\left(\frac{\partial z}{\partial x}\right)_0} = \frac{y - y_0}{\left(\frac{\partial z}{\partial y}\right)_0} = \frac{z - z_0}{-1}.$$

If the equation of the surface is given in the implicit form:

$$(4) \quad F(x, y, z) = 0,$$

then (2) and (3) become by virtue of (53) in Chap. XIV:

$$(5) \quad \left(\frac{\partial F}{\partial x}\right)_0 (x - x_0) + \left(\frac{\partial F}{\partial y}\right)_0 (y - y_0) + \left(\frac{\partial F}{\partial z}\right)_0 (z - z_0) = 0,$$

$$(6) \quad \frac{x - x_0}{\left(\frac{\partial F}{\partial x}\right)_0} = \frac{y - y_0}{\left(\frac{\partial F}{\partial y}\right)_0} = \frac{z - z_0}{\left(\frac{\partial F}{\partial z}\right)_0}.$$

For the direction cosines of the normal at (x, y, z) we have, on dropping the subscript:

$$(7) \quad \cos \alpha : \cos \beta : \cos \gamma = \frac{\partial F}{\partial x} : \frac{\partial F}{\partial y} : \frac{\partial F}{\partial z}.$$

Example. Consider the ellipsoid :

$$\frac{x^2}{a^2} + \frac{y^2}{b^2} + \frac{z^2}{c^2} = 1.$$

Here

$$\frac{2x_0}{a^2}(x - x_0) + \frac{2y_0}{b^2}(y - y_0) + \frac{2z_0}{c^2}(z - z_0) = 0$$

or

$$\frac{x_0x}{a^2} + \frac{y_0y}{b^2} + \frac{z_0z}{c^2} = 1$$

for the tangent plane; and for the normal :

$$a^2 \frac{x - x_0}{x_0} = b^2 \frac{y - y_0}{y_0} = c^2 \frac{z - z_0}{z_0}.$$

EXERCISES

1. Find the equation of the tangent plane and the normal of the cone :

$$z^2 = 2x^2 + y^2,$$

at the point (2, 1, 3).

$$\text{Ans. } 4x + y - 3z = 0; \quad \frac{x-2}{4} = y-1 = \frac{z-3}{-3}.$$

2. How far distant from the origin is the tangent plane to the ellipsoid :

$$x^2 + 3y^2 + 2z^2 = 9$$

at the point (2, -1, 1) ?

Ans. 2.182.

3. Determine the angle between the normal to the ellipsoid in the preceding question at the point (2, -1, 1) and the line joining the origin with this point.

2. Tangent Line and Normal Plane of a Space Curve. A curve in space may be given analytically

(a) by expressing its coordinates as functions of a parameter :

$$(8) \quad x = f(t), \quad y = \phi(t), \quad z = \psi(t);$$

(b) as the intersection of two cylinders :

$$(9) \quad y = \phi(x), \quad z = \psi(x);$$

(c) as the intersection of two arbitrary surfaces:

$$(10) \quad F(x, y, z) = 0, \quad \Phi(x, y, z) = 0.$$

A familiar example of (a) in the case of plane curves is the cycloid; also the circle. In the case of space curves we have the helix:

$$(11) \quad x = a \cos \theta, \quad y = a \sin \theta, \quad z = b\theta.$$

This curve winds round the cylinder $x^2 + y^2 = a^2$, its steepness always keeping the same. It is the curve of the thread of a screw that does not taper. Again, if a body is moving under a given law of force the coordinates of its centre of gravity are functions of the time, and we may think of these as expressed in the form (a). But the student must not regard it as essential that we find a simple geometrical or mechanical interpretation for t in (a). Thus if we write arbitrarily:

$$(12) \quad x = \log t, \quad y = \sin t, \quad z = \frac{t}{\sqrt[3]{1+t^2}},$$

we get a definite curve, t entering purely analytically.

In particular, we can always choose as the parameter t in (a) the length of the arc of the curve, measured from an arbitrary point:

$$(13) \quad x = f(s), \quad y = \phi(s), \quad z = \psi(s).$$

The form (b) may be regarded as a special case under (a), namely that in which

$$x = t.$$

On the other hand, it is a special case under (c).

The Direction Cosines. To find the direction cosines of the tangent to a space curve at a point $P: (x_0, y_0, z_0)$, pass a secant through P and a neighboring point $P': (x_0 + \Delta x, y_0 + \Delta y, z_0 + \Delta z)$. The direction cosines of the secant are:

$$\cos \alpha' = \frac{\Delta x}{PP'}, \quad \cos \beta' = \frac{\Delta y}{PP'}, \quad \cos \gamma' = \frac{\Delta z}{PP'},$$

and hence, for the tangent,

$$\cos \alpha = \lim_{\overline{PP'} \rightarrow 0} \frac{\Delta x}{\overline{PP'}} = \lim_{\overline{PP'} \rightarrow 0} \left(\frac{\Delta x}{\Delta s} \cdot \frac{\Delta s}{\overline{PP'}} \right) = D_s x,$$

with similar formulas for $\cos \beta$, $\cos \gamma$. Hence

$$(14) \quad \cos \alpha = \frac{dx}{ds}, \quad \cos \beta = \frac{dy}{ds}, \quad \cos \gamma = \frac{dz}{ds}.$$

Here the tangent is thought of as drawn in the direction in which s is increasing. If it is drawn in the opposite direction, the minus sign must precede each derivative.

From (14) it follows at once that

$$(15) \quad ds^2 = dx^2 + dy^2 + dz^2.$$

This important formula can be proven directly from the relation

$$\overline{PP'}^2 = \Delta x^2 + \Delta y^2 + \Delta z^2.$$

If we assume the form (a),

$$ds^2 = [f'(t)^2 + \phi'(t)^2 + \psi'(t)^2] dt^2$$

and

$$(16) \quad \left\{ \begin{aligned} \cos \alpha &= \frac{f'(t)}{\sqrt{f'(t)^2 + \phi'(t)^2 + \psi'(t)^2}}, \\ \cos \beta &= \frac{\phi'(t)}{\sqrt{f'(t)^2 + \phi'(t)^2 + \psi'(t)^2}}, \\ \cos \gamma &= \frac{\psi'(t)}{\sqrt{f'(t)^2 + \phi'(t)^2 + \psi'(t)^2}}. \end{aligned} \right.$$

$$(17) \quad s = \int_{t_0}^{t_1} \sqrt{f'(t)^2 + \phi'(t)^2 + \psi'(t)^2} dt.$$

Applying these results to (9), we get

$$(18) \quad \cos \alpha = \frac{1}{\sqrt{1 + \frac{dy^2}{dx^2} + \frac{dz^2}{dx^2}}}, \quad \text{etc.,}$$

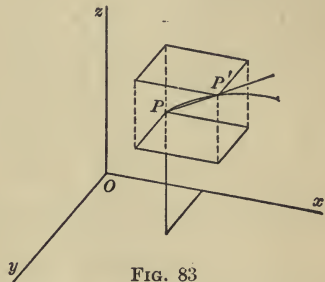

FIG. 83

$$(19) \quad s = \int_{x_0}^{x_1} \sqrt{1 + \frac{dy^2}{dx^2} + \frac{dz^2}{dx^2}} dx.$$

The Equations of the Tangent Line and the Normal Plane.
For the tangent line we have, in case (a) :

$$(20) \quad \frac{x - x_0}{f'(t_0)} = \frac{y - y_0}{\phi'(t_0)} = \frac{z - z_0}{\psi'(t_0)};$$

and in (b) :

$$(21) \quad y - y_0 = \left(\frac{dy}{dx}\right)_0 (x - x_0), \quad z - z_0 = \left(\frac{dz}{dx}\right)_0 (x - x_0).$$

The normal plane is given by

$$(22) \quad f'(t_0)(x - x_0) + \phi'(t_0)(y - y_0) + \psi'(t_0)(z - z_0) = 0$$

in (a) ; and in (b) by

$$(23) \quad x - x_0 + \left(\frac{dy}{dx}\right)_0 (y - y_0) + \left(\frac{dz}{dx}\right)_0 (z - z_0) = 0.$$

On the other hand, the tangent line in case (c) may be obtained most simply as the intersection of the tangent planes to the surfaces at the point in question :

$$(24) \quad \left\{ \begin{array}{l} \left(\frac{\partial F}{\partial x}\right)_0 (x - x_0) + \left(\frac{\partial F}{\partial y}\right)_0 (y - y_0) + \left(\frac{\partial F}{\partial z}\right)_0 (z - z_0) = 0, \\ \left(\frac{\partial \Phi}{\partial x}\right)_0 (x - x_0) + \left(\frac{\partial \Phi}{\partial y}\right)_0 (y - y_0) + \left(\frac{\partial \Phi}{\partial z}\right)_0 (z - z_0) = 0. \end{array} \right.$$

These equations may be thrown into the equivalent form :

$$(25) \quad \frac{x - x_0}{\left| \begin{array}{cc} F_y & F_z \\ \Phi_y & \Phi_z \end{array} \right|_0} = \frac{y - y_0}{\left| \begin{array}{cc} F_x & F_z \\ \Phi_x & \Phi_z \end{array} \right|_0} = \frac{z - z_0}{\left| \begin{array}{cc} F_x & F_y \\ \Phi_x & \Phi_y \end{array} \right|_0}.$$

Hence we see that the direction cosines of the tangent line to the curve of intersection of the surfaces (10) are given at (x, y, z) by the proportion :

$$(26) \quad \cos \alpha : \cos \beta : \cos \gamma = \left| \begin{array}{cc} F_y & F_z \\ \Phi_y & \Phi_z \end{array} \right| : \left| \begin{array}{cc} F_x & F_z \\ \Phi_x & \Phi_z \end{array} \right| : \left| \begin{array}{cc} F_x & F_y \\ \Phi_x & \Phi_y \end{array} \right|.$$

The equations of the normal plane can now be written down at once.

EXERCISES

Find the equations of the tangent line and the normal plane to the following space curves :

1. The helix (11) and the curve (12).

2. The curve: $y^2 = 2mx, \quad z^2 = m - x.$

3. The curve: $2x^2 + 3y^2 + z^2 = 9, \quad z^2 = 3x^2 + y^2,$
at the point $(1, -1, 2).$

4. Find the angle that the tangent line in the preceding question makes with the axis of $x.$

5. Compute the length of the arc of the helix :

$$x = \cos \theta, \quad y = \sin \theta, \quad 5z = \theta,$$

when it has made one complete turn around the cylinder.

6. How steep is the helix in the preceding question?

7. Show that the condition that the surfaces (10) cut orthogonally is that

$$(27) \quad \frac{\partial F}{\partial x} \frac{\partial \Phi}{\partial x} + \frac{\partial F}{\partial y} \frac{\partial \Phi}{\partial y} + \frac{\partial F}{\partial z} \frac{\partial \Phi}{\partial z} = 0.$$

8. Show that the condition that the three surfaces :

$$F(x, y, z) = 0, \quad \Phi(x, y, z) = 0, \quad \Psi(x, y, z) = 0,$$

intersecting at the point $(x_0, y_0, z_0),$ be tangent to one and the same line there is that, in this point;

$$(28) \quad J = \begin{vmatrix} \frac{\partial F}{\partial x} & \frac{\partial F}{\partial y} & \frac{\partial F}{\partial z} \\ \frac{\partial \Phi}{\partial x} & \frac{\partial \Phi}{\partial y} & \frac{\partial \Phi}{\partial z} \\ \frac{\partial \Psi}{\partial x} & \frac{\partial \Psi}{\partial y} & \frac{\partial \Psi}{\partial z} \end{vmatrix} = 0.$$

It is assumed that in no row do all the elements vanish.

9. The surfaces

$$x^2 + y^2 + z^2 = 3, \quad xyz = 1, \quad z = xy,$$

all go through the point (1, 1, 1). Find the angles at which they intersect there.

10. Obtain the condition that the surface (4) and the curve (8) meet at right angles.

11. Find the direction of the curve

$$x = t^2, \quad y = t^3, \quad z = t^4$$

in the point (1, 1, 1).

12. Find the direction of the curve

$$xyz = 1, \quad y^2 = x$$

in the point (1, 1, 1).

13. Find all the points in which the curve

$$x = t^2, \quad y = t^3, \quad z = t^4$$

meets the surface

$$z^2 = x + 2y - 2,$$

and show that, when it meets the surface, it is tangent to it.

14. Show that the surfaces

$$xyz = 1, \quad \frac{x^2}{a^2} + \frac{y^2}{b^2} - \frac{z^2}{c^2} = 1,$$

in general never cut orthogonally; but that, if

$$\frac{1}{a^2} + \frac{1}{b^2} - \frac{1}{c^2} = 0,$$

they cut orthogonally along their whole line of intersection.

15. When will the spheres

$$x^2 + y^2 + z^2 = 1, \quad (x - a)^2 + (y - b)^2 + (z - c)^2 = 1$$

cut orthogonally?

16. Two space curves have their equations written in the form (13). They intersect at a point P . Show that the angle ϵ between them at P is given by the equation:

$$\cos \epsilon = x'_1 x'_2 + y'_1 y'_2 + z'_1 z'_2,$$

where
$$x'_1 = \frac{dx_1}{ds_1}, \text{ etc.}$$

17. The ellipsoid: $x^2 + 3y^2 + 2z^2 = 9$ and the sphere: $x^2 + y^2 + z^2 = 6$ intersect in the point $(2, 1, 1)$. Find the angle between their tangent planes at this point.

3. **The Osculating Plane.** Let $P: (x_0, y_0, z_0)$ be an arbitrary point of a space curve (8), and pass a plane

$$(29) \quad A(x - x_0) + B(y - y_0) + C(z - z_0) = 0$$

through P . Then the distance D of a point

$$P': \quad x = f(t_0 + h), \quad y = \phi(t_0 + h), \quad z = \psi(t_0 + h)$$

of the curve from this plane will be in general an infinitesimal of the first order with reference to $\overline{PP'}$ as principal infinitesimal. For

$$\pm D = \frac{A(x - x_0) + B(y - y_0) + C(z - z_0)}{\sqrt{A^2 + B^2 + C^2}},$$

where x, y, z are the coordinates of P' .

Hence

$$\pm D = \frac{A[f(t_0 + h) - f(t_0)] + B[\phi(t_0 + h) - \phi(t_0)] + \text{etc.}}{\sqrt{A^2 + B^2 + C^2}}.$$

Applying Taylor's Theorem with the Remainder to each bracket:

$$f(t_0 + h) - f(t_0) = hf'(t_0) + \frac{h^2}{2} f''(t_0 + \theta h),$$

etc.,

and setting $\sqrt{A^2 + B^2 + C^2} = \Delta$, we obtain

$$\begin{aligned} \pm D &= h[Af'(t_0) + B\phi'(t_0) + C\psi'(t_0)]/\Delta \\ &+ \frac{h^2}{2}[Af''(t_0 + \theta h) + B\phi''(t_0 + \theta_1 h) + C\psi''(t_0 + \theta_2 h)]/\Delta. \end{aligned}$$

Hence

$$\lim_{P' \rightarrow P} \frac{\pm D}{h} = \frac{Af'(t_0) + B\phi'(t_0) + C\psi'(t_0)}{\Delta},$$

and this will not $= 0$ if A, B, C are chosen at random, unless P happens to be a point at which $f'(t_0), \phi'(t_0), \psi'(t_0)$ all vanish. We exclude this case. On the other hand, $PP' = \Delta s$ and $h = \Delta t$ are infinitesimals of the same order, since

$$\lim_{\Delta t \neq 0} \frac{\Delta s}{\Delta t} = D_t s = \sqrt{f'(t_0)^2 + \phi'(t_0)^2 + \psi'(t_0)^2} \neq 0.$$

Thus the above statement is proven.

If, however, $A, B,$ and C are so chosen that

$$(30) \quad Af'(t_0) + B\phi'(t_0) + C\psi'(t_0) = 0,$$

then $\lim \pm D/h = 0$ and

$$\lim_{P' \neq P} \frac{\pm D}{h^2} = \frac{Af''(t_0) + B\phi''(t_0) + C\psi''(t_0)}{2\Delta}.$$

Now (30) is precisely the condition that the tangent line to (8) be perpendicular to the normal to the plane (29), and hence the tangent will lie in this plane; *i.e.* the plane (29) is here tangent to the curve, and D becomes now in general an infinitesimal of the second order. But if $A, B,$ and C are furthermore subject to the restriction that

$$(31) \quad Af''(t_0) + B\phi''(t_0) + C\psi''(t_0) = 0,$$

then even $\lim \pm D/h^2 = 0$ and D becomes an infinitesimal of still higher order; — of the *third* order, as is readily shown, if

$$Af'''(t_0) + B\phi'''(t_0) + C\psi'''(t_0) \neq 0.$$

Equations (30) and (31) serve in general to define the ratios of the coefficients A, B, C uniquely. The latter may, therefore, be eliminated from (29), (30), and (31), and thus we obtain the equation of the *osculating plane*:

$$(32) \quad \begin{vmatrix} x - x_0 & y - y_0 & z - z_0 \\ f'(t_0) & \phi'(t_0) & \psi'(t_0) \\ f''(t_0) & \phi''(t_0) & \psi''(t_0) \end{vmatrix} = 0.$$

The osculating plane as thus defined is a tangent plane having contact of higher order than one of the tangent planes

taken at random. There is in general only one osculating plane at a given point. But in the case of a straight line all tangent planes osculate. Again, if $f''(t_0) = \phi''(t_0) = \psi''(t_0) = 0$, the same is true. The osculating plane cuts the curve in general at the point of tangency; for the numerator of the expression for $\pm D$ changes sign when h passes through the value 0.

It is easy to make a simple model that will show the osculating plane approximately. Wind a piece of soft iron wire round a broom handle, thus making a helix, and then cut out an inch of the wire and lay it down on a table. The piece will look almost like a plane curve in the plane of the table, and the latter will be approximately the osculating plane.

The normal line to a space curve, drawn in the osculating plane, is called the *principal normal*. The centre of curvature lies on this line, the radius of curvature being obtained by projecting the curve orthogonally on the osculating plane and taking the radius of curvature of this projection.

If a body move under the action of any forces, the vector acceleration of its centre of gravity always lies in the osculating plane of the path.

When the equation of the curve is given in the form (9), the equation (32) becomes:

$$(33) \left(\frac{dz}{dx} \frac{d^2y}{dx^2} - \frac{dy}{dx} \frac{d^2z}{dx^2} \right)_0 (x-x_0) + \left(\frac{d^2z}{dx^2} \right)_0 (y-y_0) - \left(\frac{d^2y}{dx^2} \right)_0 (z-z_0) = 0.$$

EXERCISES

1. Find the equation of the osculating plane of the curve (12) at the point $t = \pi$.

2. Find the equation of the osculating plane of the curve of intersection of the cylinders:

$$x^2 + y^2 = a^2, \quad x^2 + z^2 = a^2,$$

and interpret the result.

Suggestion. Express x, y, z in terms of t :

$$x = a \cos t, \quad y = a \sin t, \quad z = a \sin t.$$

3. Show that the centre of curvature of a helix lies on the radius of the cylinder produced.

4. Show that the osculating plane of the curve

$$y = x^2, \quad z^2 = 1 - y$$

at the point $(0, 0, 1)$ has contact of higher order than the second.

4. **Confocal Quadrics.*** Consider the family of surfaces:

$$(34) \quad \frac{x^2}{a^2 + \lambda} + \frac{y^2}{b^2 + \lambda} + \frac{z^2}{c^2 + \lambda} = 1, \quad a > b > c > 0,$$

where λ is a parameter taking on different values. Each surface of the family is symmetric with regard to each of the coordinate planes. We may, therefore, confine ourselves to the first octant.

If $\lambda > -c^2$, we have an ellipsoid, which for large positive values of λ resembles a huge sphere. As λ decreases, the surface contracts, and as λ approaches $-c^2$, the ellipsoid, whose equation can be thrown into the form:

$$z^2 = (c^2 + \lambda) \left(1 - \frac{x^2}{a^2 + \lambda} - \frac{y^2}{b^2 + \lambda} \right),$$

* No further knowledge of quadric surfaces is here involved than their mere classification when their equation is written in the normal form

$$\frac{x^2}{a^2} \pm \frac{y^2}{b^2} \pm \frac{z^2}{c^2} = 1.$$

See Bailey and Woods, *Analytic Geometry*, p. 316. It is desirable that the student have access to models of the three types here involved.

The student should work out for himself, after a first reading of this paragraph, the corresponding treatment of the confocal conics in the plane:

$$\frac{x^2}{a^2 + \lambda} + \frac{y^2}{b^2 + \lambda} = 1.$$

flattens down toward the plane $z=0$ as its limit, — more precisely, toward the surface of the ellipsoid

$$\frac{x^2}{a^2 - c^2} + \frac{y^2}{b^2 - c^2} = 1, \quad z = 0.$$

In so doing, it sweeps out the whole first octant just once, as we shall presently show analytically.

Let λ continue to decrease. We then get the family :

$$(35) \quad \frac{x^2}{a^2 + \mu} + \frac{y^2}{b^2 + \mu} - \frac{z^2}{-(c^2 + \mu)} = 1, \quad -b^2 < \mu < -c^2.$$

These are hyperboloids of one nappe, and they rise from coincidence with the plane $z=0$ for values of μ just under $-c^2$, sweep out the whole octant, and flatten out again toward the plane $y=0$ as their limit when μ approaches $-b^2$.

Finally, let λ trace out the interval from $-b^2$ to $-a^2$. We then get the hyperboloids of two nappes :

$$(36) \quad \frac{x^2}{a^2 + \nu} - \frac{y^2}{-(b^2 + \nu)} - \frac{z^2}{-(c^2 + \nu)} = 1, \quad -a^2 < \nu < -b^2.$$

These start from coincidence with the plane $y=0$ when ν is near $-b^2$, sweep out the octant, and approach the plane $x=0$ as ν approaches $-a^2$.

THEOREM 1. *Through each point of the first octant passes one surface of each family, and only one.*

Let $P: (x, y, z)$, be an arbitrary point of this octant. Then $x > 0, y > 0, z > 0$. Hold x, y, z fast and consider the function of λ :

$$f(\lambda) = \frac{x^2}{a^2 + \lambda} + \frac{y^2}{b^2 + \lambda} + \frac{z^2}{c^2 + \lambda} - 1.$$

The function is continuous except when $\lambda = -c^2, -b^2, \text{ or } -a^2$. In the interval $-c^2 < \lambda < +\infty$ we have*

$$f(+\infty) = -1, \quad \lim_{\lambda \rightarrow -c^2+} f(\lambda) = +\infty.$$

* The notation $\lim_{x \rightarrow a+} f(x), \lim_{x \rightarrow a-} f(x)$ is explained in Chap. XI, § 9.

Hence the curve

$$\eta = f(\lambda)$$

crosses the axis of abscissas *at least* once in this interval.

On the other hand

$$f'(\lambda) = -\frac{x^2}{(a^2 + \lambda)^2} - \frac{y^2}{(b^2 + \lambda)^2} - \frac{z^2}{(c^2 + \lambda)^2} < 0.$$

Hence $f(\lambda)$ always increases as λ decreases, and so the curve cuts the axis *only once* in this interval. We see, therefore, that one and only one ellipsoid passes through the point P .

Similar reasoning applied to the intervals $(-b^2, -c^2)$ and $(-a^2, -b^2)$ shows that one and only one hyperbola of one nappe, and one and only one hyperbola of two nappes pass through P .

THEOREM 2. *The three quadrics through P intersect at right angles there.*

The condition that two surfaces intersect at right angles is given by (27). Applying this theorem to (34) and (35) we wish to show that

$$\frac{2x}{a^2 + \lambda} \frac{2x}{a^2 + \mu} + \frac{2y}{b^2 + \lambda} \frac{2y}{b^2 + \mu} + \frac{2z}{c^2 + \lambda} \frac{2z}{c^2 + \mu} = 0.$$

Now subtract (35) from (34) :

$$(\mu - \lambda) \left[\frac{x^2}{(a^2 + \lambda)(a^2 + \mu)} + \frac{y^2}{(b^2 + \lambda)(b^2 + \mu)} + \frac{z^2}{(c^2 + \lambda)(c^2 + \mu)} \right] = 0,$$

and since $\mu - \lambda \neq 0$, this proves the theorem.

The three systems of surfaces that we have here investigated are analogous to the three families of planes in cartesian coordinates, to the spheres, planes, and cones in spherical polar coordinates, and to the planes, cylinders, and planes in cylindrical polar coordinates. They form what is called an *orthogonal system* of surfaces, and enable us to assign to the points of the first octant the coordinates (λ, μ, ν) , where

$$-c^2 < \lambda < +\infty, \quad -b^2 < \mu < -c^2, \quad -a^2 < \nu < -b^2.$$

5. Curves on the Sphere, Cylinder, and Cone. In order to study the properties of curves drawn on the surface of a sphere, we introduce as coordinates of the points of the surface the longitude θ and the latitude ϕ . Any curve can then be represented by the equation

$$(37) \quad F(\theta, \phi) = 0.$$

To determine the angle ω between this curve and a parallel of latitude, draw the meridians and the parallels of latitude through an arbitrary point $P : (\theta_0, \phi_0)$ and a neighboring point $P' : (\theta_0 + \Delta\theta, \phi_0 + \Delta\phi)$ of this curve. We thus obtain a small curvilinear rectangle, of which the arc PP' is the diagonal. We wish to determine the angle

$$\omega = \angle MPP'.$$

Now consider, alongside of the curvilinear right triangle MPP' a rectilinear right triangle whose hypotenuse is the chord PP' and one of whose legs is the perpendicular PM_1 let fall from P on the meridian plane through P' . The angle

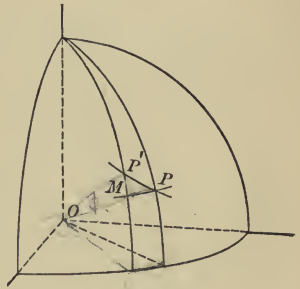

FIG. 84

$$\omega' = \angle M_1PP'$$

of this triangle evidently approaches ω as its limit when P' approaches P .

We have:

$$\tan \omega' = \frac{M_1P'}{PM_1}.$$

Now PM_1 differs from $\widetilde{PM} = a \cos \phi_0 \Delta\theta$ by an infinitesimal of higher order and likewise M_1P' differs from $\widetilde{MP}' = a \Delta\phi$ by an infinitesimal of higher order. Hence, by the theorem of Chap. V, § 2, we obtain:

$$\lim_{P' \rightarrow P} \tan \omega' = \lim_{P' \rightarrow P} \frac{M_1P'}{PM_1} = \lim_{\Delta\theta \rightarrow 0} \frac{a \Delta\phi}{a \cos \phi_0 \Delta\theta},$$

$$\tan \omega = \frac{1}{\cos \phi_0} D_\theta \phi,$$

or, dropping the subscript:

$$(38) \quad \tan \omega = \frac{1}{\cos \phi} \frac{d\phi}{d\theta}.$$

In order to obtain the differential of the arc of the curve (37) we write down the Pythagorean Theorem for the triangle PM_1P' :

$$\overline{PP'}^2 = PM_1^2 + M_1P'^2,$$

divide through by $\Delta\theta^2$ and then let $\Delta\theta$ approach 0 as its limit. Since the chord PP' differs from the arc Δs by an infinitesimal of higher order, we have:

$$\lim_{P' \neq P} \left(\frac{PP'}{\Delta\theta} \right)^2 = \lim_{P' \neq P} \left(\frac{\Delta s}{\Delta\theta} \right)^2 = \alpha^2 \cos^2 \phi_0 + \alpha^2 \lim_{P' \neq P} \left(\frac{\Delta\phi}{\Delta\theta} \right)^2,$$

$$(D_\theta s)^2 = \alpha^2 \cos^2 \phi + \alpha^2 (D_\theta \phi)^2,$$

$$(39) \quad ds^2 = \alpha^2 [\cos^2 \phi d\theta^2 + d\phi^2].$$

Rhumb Lines. A *rhumb line* or *loxodrome* is the path of a ship that sails without altering her course, *i.e.* a curve that cuts the meridians always at one and the same angle. If we denote the complement of this angle by ω , then we have from (38) for the determination of the curve:

$$\frac{d\phi}{\cos \phi} = d\theta \tan \omega,$$

$$(40) \quad \theta \tan \omega = \int \frac{d\phi}{\cos \phi} = \log \tan \left(\frac{\phi}{2} + \frac{\pi}{4} \right) + C.$$

This is the equation of an equiangular spiral on the sphere, which winds round each of the poles an infinite number of times.

EXERCISES

1. Show that the total length of a rhumb line on the sphere is finite.

2. The cartesian coordinates of a point on the surface of a sphere are given by the equations :

$$x = a \cos \phi \cos \theta, \quad y = a \cos \phi \sin \theta, \quad z = a \sin \phi.$$

Deduce (39) from these relations and the equation :

$$ds^2 = dx^2 + dy^2 + dz^2.$$

3. Taking as the coordinates of a point on the surface of a cone (ρ, θ) , where ρ is the distance from the vertex and θ is the longitude, show that

$$(41) \quad \tan \omega = \frac{d\rho}{\rho d\theta \sin \alpha}.$$

4. Obtain the equation and the length of a rhumb line on the cone.

5. The preceding two questions for a cylinder.

6. **Mercator's Chart.** In mapping the earth on a sheet of paper it is not possible to preserve the shapes of the countries and the islands, the lakes and the peninsulas represented. Some distortion is inevitable, and the problem of cartography is to render its disturbing effect as slight as possible. This demand will be met satisfactorily if we can make the angle at which two curves intersect on the earth's surface go over into the same angle on the map. For then a small triangle on the surface of the earth, made by arcs of great circles, will appear in the map as a small curvilinear triangle having the same angles and almost straight sides, and so it will look very similar to the original triangle. What is true of triangles is true of other small figures, and thus we should get a map in which Cuba will look like Cuba and Iceland like Iceland, though the scale for Cuba and the scale for Iceland may be quite different.

A map meeting the above requirement may be made as follows. Regarding the earth as a perfect sphere, construct a cylinder tangent to the earth along the equator. Then the

meridians shall go over into the elements of the cylinder and the parallels of latitude into its circular cross-sections as follows: Let P be an arbitrary point on the earth, Q , its image on the cylinder.

(a) Q shall have the same longitude, θ , as P .

(b) To the latitude ϕ of P shall correspond a distance z of Q from the equator such that the angle ω which an arbitrary curve C through P makes with the parallel of latitude through P and the angle ω_1 which the image C_1 of C makes with the circular section of the cylinder through Q shall be the same. Now from (38)

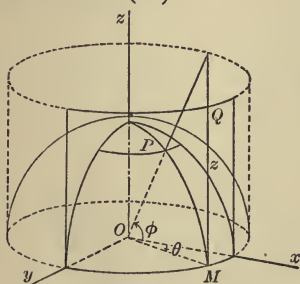

FIG. 85

$$\tan \omega = \frac{d\phi}{d\theta \cos \phi}.$$

On the other hand,

$$\tan \omega_1 = \frac{dz}{a d\theta}.$$

Hence, setting a for convenience = 1, we get

$$\frac{d\phi}{d\theta \cos \phi} = \frac{dz}{d\theta} \quad \text{or} \quad dz = \frac{d\phi}{\cos \phi},$$

$$z = \int \frac{d\phi}{\cos \phi} = \log \tan \left(\frac{\phi}{2} + \frac{\pi}{4} \right),$$

the constant of integration vanishing because $z = 0$ corresponds to $\phi = 0$.

Thus a point in latitude 60° N. goes over into a point distant 1.32 units from the equator.

The cylinder can now be cut along an element, rolled out on a plane, and the map thus obtained reduced to the desired scale.

This map is known as Mercator's Chart.* It has the property that the meridians and the parallels of latitude go over into two orthogonal families of parallel straight lines. Furthermore, a rhumb line on the earth is represented by a straight line on the map.

*G. Kremer, the latinized form of whose name was Mercator, completed a map of the world on the plan here set forth in 1569.

We call attention to the fact that the above map cannot be obtained by projecting the points of the sphere on the cylinder along a bundle of rays from the centre.

EXERCISE

Turn to an atlas and test the Mercator's charts there found by actual measurement and computation.

CHAPTER XVI

TAYLOR'S THEOREM FOR FUNCTIONS OF SEVERAL VARIABLES

1. **The Law of the Mean.** Let $f(x, y)$ be a continuous function of the two independent variables x and y , having continuous first partial derivatives. We wish to obtain an expression for

$$f(x_0 + h, y_0 + k)$$

analogous to the Law of the Mean for functions of a single variable, Chap. XI, § 2. One such expression has been found in Chap. XIV, § 6; but there is a simpler one. Form the function :

$$\Phi(t) = f(x_0 + th, y_0 + tk), \quad 0 \leq t \leq 1,$$

where x_0, y_0, h, k are constants and t alone varies. Notice that

$$\Phi(1) = f(x_0 + h, y_0 + k), \quad \Phi(0) = f(x_0, y_0).$$

If we apply the Law of the Mean, p. 230, Formula (A'), to $\Phi(t)$, setting $a = 0, b = 1$, we get :

$$\Phi(1) = \Phi(0) + 1 \cdot \Phi'(\theta), \quad 0 < \theta < 1.$$

Now $\Phi'(t) = hf_x(x_0 + th, y_0 + tk) + kf_y(x_0 + th, y_0 + tk)$.

Hence $f(x_0 + h, y_0 + k) =$

$$(1) \quad f(x_0, y_0) + hf_x(x_0 + \theta h, y_0 + \theta k) + kf_y(x_0 + \theta h, y_0 + \theta k),$$

where $0 < \theta < 1$, and this is the form we sought for the Law of the Mean for functions of two independent variables.

The extension to functions of $n > 2$ variables is obvious.

2. Taylor's Theorem. We obtain Taylor's Theorem with the Remainder if we write the corresponding theorem for $\Phi(t)$:

$$\Phi(1) = \Phi(0) + \Phi'(0) + \dots + \frac{1}{n!} \Phi^{(n)}(0) + \frac{1}{(n+1)!} \Phi^{(n+1)}(\theta),$$

and then substitute for Φ and its derivatives their values. Thus when $n = 1$ we get

$$(2) \quad f(x_0 + h, y_0 + k) = f(x_0, y_0) + hf_x(x_0, y_0) + kf_y(x_0, y_0) + \frac{1}{2}[h^2 f_{x^2}(X, Y) + 2hk f_{xy}(X, Y) + k^2 f_{y^2}(X, Y)],$$

where $X = x_0 + \theta h$, $Y = y_0 + \theta k$, and $0 < \theta < 1$.

The student should write out the formula for the next case, $n = 2$.

The general term, $\Phi^{(n)}(0)/n!$, can be expressed symbolically as

$$\frac{1}{n!} \left[h \frac{\partial}{\partial x} + k \frac{\partial}{\partial y} \right]^n f(x, y) \Bigg|_{\substack{x=x_0 \\ y=y_0}}$$

and the remainder as

$$\frac{1}{(n+1)!} \left[h \frac{\partial}{\partial x} + k \frac{\partial}{\partial y} \right]^{n+1} f(x, y) \Bigg|_{\substack{x=x_0 + \theta h \\ y=y_0 + \theta k}}.$$

The extension to functions of $n > 2$ variables is immediate.

If the remainder converges toward zero when n becomes infinite, we obtain an infinite series whose terms are homogeneous polynomials and which converges toward the value of the function. If furthermore the series whose terms consist of the monomials that make up the terms of the latter series converges for all values of h and k within certain limits: $|h| < H$, $|k| < K$, we say that the function can be *developed in a power series in $h = x - x_0$ and $k = y - y_0$* :

$$(3) \quad f(x, y) = \Sigma c_{mn} (x - x_0)^m (y - y_0)^n,$$

or that it can be *developed by Taylor's Theorem*. A series of the form (3) is often called a Taylor's Series. But it is not in general feasible to show that the remainder converges toward zero, and so other methods of analysis have to be employed to establish a Taylor's development.

3. Maxima and Minima. The function $f(x, y)$ will have a maximum at the point (x_0, y_0) if the tangent plane of the surface

$$u = f(x, y)$$

at (x_0, y_0) is parallel to the x, y plane and the surface lies below this plane at all other points of the neighborhood of (x_0, y_0, u_0) . Hence we see that at (x_0, y_0)

$$(4) \quad \frac{\partial u}{\partial x} = 0, \quad \frac{\partial u}{\partial y} = 0.$$

A similar statement holds for a minimum.

The necessary condition contained in (4) can be extended at once to functions of $n > 2$ variables. For, if any one of the first partial derivatives, $\partial u / \partial x$, for example, were $\neq 0$ at (x_0, y_0, z_0, \dots) , then the function $f(x, y_0, z_0, \dots)$, a function of x alone, would be increasing as x passes through the value x_0 , or else it would be decreasing, according to the sign of $\partial u / \partial x$.

The conditions (4) are frequently sufficient to determine a maximum or a minimum.

Example 1. Given three particles of masses m_1, m_2, m_3 , situated at the points $(x_1, y_1), (x_2, y_2), (x_3, y_3)$. To find the point about which the moment of inertia of these particles will be a minimum.

Here it is clear that for all distant points of the plane the moment of inertia is large, becoming infinite in the infinite region of the plane. Furthermore, the moment of inertia is a positive continuous function. Hence the surface

$$u = I = m_1 [(x - x_1)^2 + (y - y_1)^2] + m_2 [(x - x_2)^2 + (y - y_2)^2] \\ + m_3 [(x - x_3)^2 + (y - y_3)^2]$$

must have at least one minimum, and at such a point

$$\frac{\partial u}{\partial x} = 2 [m_1 (x - x_1) + m_2 (x - x_2) + m_3 (x - x_3)] = 0,$$

$$\frac{\partial u}{\partial y} = 2 [m_1 (y - y_1) + m_2 (y - y_2) + m_3 (y - y_3)] = 0.$$

But these equations determine the centre of gravity of the particles and are satisfied by no other point. Hence the centre of gravity is the point about which the moment of inertia is least.

The result is in accordance with the general theorem of Chap. IX, § 15, and it holds for any system of particles whatever.

Auxiliary Variables. As in the case of functions of a single variable, so here it frequently happens that it is best to express the quantity to be made a maximum or a minimum in terms of more variables than are necessary, one or more relations existing between these variables. The student must, therefore, in all cases begin by considering *how many independent variables* there are, and then write down *all* the relations between the letters that enter; and he must make up his mind as to what letters he will take as independent variables before he begins to differentiate.

Example 2. What is the volume of the greatest rectangular parallelepiped that can be inscribed in the ellipsoid:

$$(5) \quad \frac{x^2}{a^2} + \frac{y^2}{b^2} + \frac{z^2}{c^2} = 1 ?$$

We assume that the faces are to be parallel to the coordinate planes and thus obtain for the volume:

$$V = 8xyz.$$

But x, y, z cannot all be chosen at pleasure. They are connected by the relation (5). So the number of independent variables is here two, and we may take them as x and y . We have, then:

$$\frac{\partial V}{\partial x} = 8y \left(z + x \frac{\partial z}{\partial x} \right) = 0,$$

$$\frac{\partial V}{\partial y} = 8x \left(z + y \frac{\partial z}{\partial y} \right) = 0.$$

From (5) we obtain:

$$\frac{\partial z}{\partial x} = -\frac{c^2 x}{a^2 z}, \quad \frac{\partial z}{\partial y} = -\frac{c^2 y}{b^2 z}.$$

Now neither $x=0$ nor $y=0$ can lead to a solution, and the only remaining possibility is that

$$z - \frac{c^2 x^2}{a^2 z} = 0, \quad z - \frac{c^2 y^2}{b^2 z} = 0,$$

or

$$\frac{x^2}{a^2} = \frac{y^2}{b^2} = \frac{z^2}{c^2}.$$

Thus the parallelopiped whose vertices lie at the intersections of these lines with the ellipsoid, *i.e.* on the diagonals of the circumscribed parallelopiped $x = \pm a$, $y = \pm b$, $z = \pm c$, is the one required,* and its volume is

$$V = \frac{8abc}{3\sqrt{3}}.$$

EXERCISES

1. Required the parallelopiped of given volume and minimum surface. *Ans.* A cube.

2. Required the parallelopiped of given surface and maximum volume. *Ans.* A cube.

3. A tank in the form of a rectangular parallelopiped, open at the top, is to be built, and it is to hold a given amount of water. Find what proportions it should have, in order that the cost of lining it may be as small as possible. How many independent variables are there in this problem?

Ans. Length and breadth each double the depth.

* The reasoning, given at length, is as follows. V is a continuous positive function of x and y at all such points of the quadrant of the ellipse

$$\frac{x^2}{a^2} + \frac{y^2}{b^2} = 1,$$

for which $x > 0$, $y > 0$, and it vanishes on the boundary of this region. Hence it must have at least one maximum inside. But we find only one point, $x = a/\sqrt{3}$, $y = b/\sqrt{3}$ at which V can possibly be a maximum. Hence, etc.

4. Find the shortest distance between the lines

$$\begin{cases} y = 2x, \\ z = 5x, \end{cases} \quad \begin{cases} y = 3x + 7, \\ z = x. \end{cases}$$

5. Show without using the calculus that the function

$$x^4 + y^4 + 4x - 32y - 7$$

has a minimum.

Suggestion. Use polar coordinates.

6. Find the minimum in the preceding problem.

7. A hundred tenement houses of given cubical content are to be built in a factory town. They are to have a rectangular ground plan and a gable roof. Find the dimensions for which the area of walls and roof will be least.*

8. A torpedo in the form of a cylinder with equal conical ends is to be made out of boiler plates and is just to float when loaded. The displacement of the torpedo being given, what must be its proportions, that it may carry the greatest weight of dynamite?

Ans. The length of the torpedo must be three times the length of the cylindrical portion, and the diameter must be $\sqrt{5}$ times the length of the cylindrical portion.

9. Find the point so situated that the sum of its distances from the three vertices of an acute-angled triangle is a minimum.

Ans. The lines joining the point with the vertices make angles of 120° with one another.†

10. Find the most economical dimensions for a powder house of given cubical content, if it is built in the form of a cylinder and the roof is a cone.

* The problem is identical with that of finding the best shape for a wall-tent.

† For a complete discussion of the problem for any triangle see Goursat-Hedrick, *Mathematical Analysis*, vol. 1, § 62.

11. Find approximately the most economical dimensions for a two-gallon milk can. Assume the upper part of the can to be a complete cone.

4. Test by the Derivatives of the Second Order. We proceed to deduce a sufficient condition for a maximum or a minimum in terms of the derivatives of the second order. Suppose the necessary conditions (4) are fulfilled at (x_0, y_0) . Then from (2) we get:

$$(6) \quad f(x_0 + h, y_0 + k) - f(x_0, y_0) = \frac{1}{2}(Ah^2 + 2Bhk + Ck^2),$$

$$\text{where} \quad A = f_{x^2}(x_0 + \theta h, y_0 + \theta k), \quad B = f_{xy}(x_0 + \theta h, y_0 + \theta k),$$

$$C = f_{y^2}(x_0 + \theta h, y_0 + \theta k),$$

and for a minimum the difference (6) must be positive for all points $x = x_0 + h$, $y = y_0 + k$ near (x_0, y_0) except for this one point, where it vanishes.

Definite Quadratic Forms. A homogeneous polynomial of the second degree in any number of variables is called a *quadratic form*,* and is said to be *definite* if it vanishes only when all the variables vanish. Thus

$$h^2 + k^2, \quad 2h^2 + 3k^2 + 5l^2$$

are examples of definite quadratic forms in two and three variables respectively;

$$h^2, \quad 3h^2 + 7hk + 2k^2 = (3h + k)(h + 2k),$$

regarded as quadratic forms in two variables, are not definite. A definite quadratic form never changes sign.

THEOREM. *In order that*

$$U = Ah^2 + 2Bhk + Ck^2,$$

*For some purposes it is desirable to define an algebraic form merely as a polynomial. But we are concerned here only with homogeneous polynomials. Moreover, we exclude the case that all the coefficients vanish.

where A, B, C are independent of h and k , be a definite form, it is necessary and sufficient that

$$(7) \quad B^2 - AC < 0.$$

That this condition is sufficient is at once evident. For, if it is fulfilled, surely neither A nor C can vanish, and we can write:

$$U = \frac{1}{A} [(Ah + Bk)^2 + (AC - B^2)k^2].$$

Hence U can vanish only when

$$Ah + Bk = 0 \quad \text{and} \quad k = 0,$$

i.e. only when $h = k = 0$, *q. e. d.*

We leave the proof that the condition is necessary to the student.

When the condition (7) is fulfilled, A and C necessarily have the same sign, and this is the sign of U .

COROLLARY. *If A, B, C depend on h and k in any manner whatever, and if, for a pair of values (h, k) not both zero, the condition (7) is fulfilled, then for these values U has the same sign as A and C .*

Application to Maxima and Minima. Returning now to equations (6), let us suppose that

$$(8) \quad \left(\frac{\partial^2 u}{\partial x \partial y} \right)^2 - \frac{\partial^2 u}{\partial x^2} \frac{\partial^2 u}{\partial y^2} < 0$$

at (x_0, y_0) and that these derivatives are continuous in the vicinity of this point. Then the relation (8) will hold for all points near (x_0, y_0) and furthermore, for such points, both $\frac{\partial^2 u}{\partial x^2}$ and $\frac{\partial^2 u}{\partial y^2}$ will preserve the sign they have at (x_0, y_0) . Hence the right-hand side of (6) will vanish only at (x_0, y_0) , and at other points in the neighborhood will have the sign common to these latter derivatives. We are thus led to the following:

SUFFICIENT CONDITION FOR A MAXIMUM OR A MINIMUM.

If at the point (x_0, y_0)

$$(a) \quad \frac{\partial u}{\partial x} = 0 \quad \frac{\partial u}{\partial y} = 0$$

$$(b) \quad \left(\frac{\partial^2 u}{\partial x \partial y} \right)^2 - \frac{\partial^2 u}{\partial x^2} \frac{\partial^2 u}{\partial y^2} < 0$$

and if the derivatives of the second order are continuous near (x_0, y_0) , then u will have a maximum at (x_0, y_0) if

$$(c_1) \quad \frac{\partial^2 u}{\partial x^2} < 0,$$

and a minimum there if

$$(c_2) \quad \frac{\partial^2 u}{\partial x^2} > 0.$$

Conditions (b) and (c) are not necessary, but only sufficient. u may have a maximum or a minimum even when the sign of inequality in (b) is replaced by the sign of equality. But if, in (b), the sign of inequality is reversed, u has neither a maximum nor a minimum.

When f depends on $n > 2$ variables, the method of procedure is similar. First, the algebraic theorem about quadratic forms has to be generalized. Thus for three variables,

$$(9) \quad U = a_{11}x_1^2 + a_{22}x_2^2 + a_{33}x_3^2 + 2a_{12}x_1x_2 + 2a_{13}x_1x_3 + 2a_{23}x_2x_3,$$

and the necessary and sufficient condition that U be a positive definite quadratic form is that

$$(10) \quad a_{11} > 0, \quad \begin{vmatrix} a_{11} & a_{12} \\ a_{21} & a_{22} \end{vmatrix} > 0, \quad \begin{vmatrix} a_{11} & a_{12} & a_{13} \\ a_{21} & a_{22} & a_{23} \\ a_{31} & a_{32} & a_{33} \end{vmatrix} > 0,$$

where $a_{ij} = a_{ji}$. This form of statement suggests the generalization for $n = n$.

If U is to be a negative definite quadratic form, the first, third, fifth, etc. inequality signs in (10) must be reversed. For a proof by Gibbs, arranged by Saurel, cf. the *Annals of Mathematics*, ser. 2, vol. 4 (1902-03), p. 62.

The case of implicit functions, treated by Lagrange's multipliers, is given in Goursat-Hedrick, *Mathematical Analysis*, vol. 1, § 61.

EXERCISES

1. Show that the surface

$$z = xy$$

has neither a maximum nor a minimum at the origin.

2. Test the function

$$x^3 + 3x^2 - 2xy + 5y^2 - 4y^3$$

for maxima and minima.

3. Determine the maxima and minima of the surface

$$x^2 + 2y^2 + 3z^2 - 2xy - 2yz = 2.$$

CHAPTER XVII

ENVELOPES

1. Envelope of a Family of Curves. Consider a family of circles, of equal radii, whose centres all lie on a right line :

$$(1) \quad (x - \alpha)^2 + y^2 = 1,$$

where the parameter α runs through all values. The lines

$$(2) \quad y = 1 \quad \text{and} \quad y = -1$$

are touched by all the curves of this family.

Again, let a rod slide with one end on the floor and the other touching a vertical wall, the rod always remaining in the same vertical plane. It is clear that the rod in its successive positions is always tangent to a certain curve. This curve, like the lines (2) in the preceding example, is called the *envelope* of the family of curves.



FIG. 86

Turning now to the general case, we see that the family of curves

$$(3) \quad f(x, y, \alpha) = 0$$

may have one or more curves to which, as α varies, the successive members of the family are tangent. When this is so, two curves of the family corresponding to values of α differing but slightly from each other :

$$(4) \quad f(x, y, \alpha_0) = 0, \quad f(x, y, \alpha_0 + \Delta\alpha) = 0,$$

will usually intersect near the points of contact of these curves with the envelope, as is illustrated in the above examples. So if we determine the limiting position of this point P of intersection of the curves (4), we shall obtain a point of the envelope. Now a third curve through P is the following:

$$(5) \quad 0 = f(x, y, \alpha_0 + \Delta\alpha) - f(x, y, \alpha_0) = \Delta\alpha f_\alpha(x, y, \alpha_0 + \theta\Delta\alpha).$$

For, the coordinates of P satisfy the equation of this curve. Hence, allowing $\Delta\alpha$ to approach 0, we get*

$$(6) \quad f_\alpha(x, y, \alpha_0) = 0.$$

Thus the coordinates of a point of the envelope, when one exists, are seen to satisfy the simultaneous equations:

$$(7) \quad \begin{cases} f(x, y, \alpha) = 0, \\ \frac{\partial f}{\partial \alpha} = f_\alpha(x, y, \alpha) = 0. \end{cases}$$

Conversely, the locus (7) will be tangent to each curve (3) provided that $\partial f/\partial x, \partial f/\partial y$ do not both vanish along this locus. To prove this, observe that the slope of a curve of the family (3) is given by the equation:

$$(8) \quad \frac{\partial f}{\partial x} + \frac{\partial f}{\partial y} \frac{dy}{dx} = 0.$$

In order to find the slope of the envelope, we may think of equations (7) as solved for x and y :

$$(9) \quad x = \phi(\alpha), \quad y = \psi(\alpha).$$

* The reasoning, in detail, is as follows. We assume that the coordinates x, y of the point P vary continuously as $\Delta\alpha$ approaches 0, and approach a definite limiting point. The coordinates of P satisfy (5) and hence

$$f_\alpha(x, y, \alpha_0 + \theta\Delta\alpha) = 0.$$

Finally, we assume $f_\alpha(x, y, \alpha)$ to be a continuous function of x, y , and α , and so

$$\lim_{\Delta\alpha \rightarrow 0} f_\alpha(x, y, \alpha_0 + \theta\Delta\alpha) = f_\alpha(x, y, \alpha_0) = 0.$$

Then the slope of the envelope is

$$\frac{dy}{dx} = \frac{\psi'(\alpha)}{\phi'(\alpha)}.$$

Now take the total differential of $f(x, y, \alpha)$:

$$df = \frac{\partial f}{\partial x} dx + \frac{\partial f}{\partial y} dy + \frac{\partial f}{\partial \alpha} d\alpha.$$

If x and y satisfy (9), then $df = 0$, $dx = \phi'(\alpha) d\alpha$, $dy = \psi'(\alpha) d\alpha$, and $\frac{\partial f}{\partial \alpha} = 0$. Hence

$$(10) \quad 0 = \frac{\partial f}{\partial x} dx + \frac{\partial f}{\partial y} dy \quad \text{or} \quad \frac{\partial f}{\partial x} + \frac{\partial f}{\partial y} \frac{\psi'(\alpha)}{\phi'(\alpha)} = 0.$$

Thus (10) gives the same slope that (8) does, and the envelope is tangent to the family.

Example 1. Applying the formulas (7) to the family of circles (1) we get:

$$\frac{\partial f}{\partial \alpha} = -2(x - \alpha) = 0.$$

The elimination of α between this equation and (1) gives

$$y^2 = 1 \quad \text{or} \quad y = 1 \text{ and } y = -1.$$

Example 2. To find the envelope of the family of ellipses whose axes coincide and whose areas are constant.

Here,

$$(a) \quad \frac{x^2}{a^2} + \frac{y^2}{b^2} = 1,$$

$$(b) \quad \pi ab = k.$$



FIG. 87

It is more convenient to retain both parameters, rather than to eliminate, but we must be careful to remember that only one is independent. If we choose a as that one, $a = \alpha$, and differentiate with respect to α , we have:

$$-\frac{2x^2}{a^3} - \frac{2y^2}{b^3} \frac{db}{da} = 0, \quad \pi \left(b + a \frac{db}{da} \right) = 0,$$

and hence

$$(c) \quad \frac{x^2}{a^2} = \frac{y^2}{b^2}.$$

Between (a), (b), and (c) we can eliminate a and b and thus get a single equation in x and y , which will be the equation of the envelope. To do this, solve (a) and (c) for a^2 and b^2 , thus getting

$$a^2 = 2x^2, \quad b^2 = 2y^2,$$

and then substitute the values of a and b from these equations in (b):

$$\pm 2\pi xy = k,$$

a pair of equilateral hyperbolas.

The equations

$$x = \pm a\sqrt{2}, \quad y = \pm b\sqrt{2},$$

combined with (b), give the coordinates of the points of the envelope in which the particular ellipse corresponding to that pair of values of a and b is tangent to it. This remark applies generally whenever the coordinates x and y of a point of the envelope are obtained as functions of α .

EXERCISES

In each of the following questions draw a rough figure to indicate the curves of the family and the envelope.

1. Find the envelope of the family of parabolas:

$$y^2 = 3ax - a^3.$$

2. Circles are drawn on the double ordinates of a parabola as diameters. Show that their envelope is an equal parabola.

3. Show that the envelope of all ellipses having coincident axes, the straight line joining the extremities of the axes being of constant length, is a square.

4. Find the envelope of straight lines drawn perpendicular to the normals of a parabola at the points where they cut the axis.

5. Show that the envelope of the lines in the second example of § 1, p. 344, is an arc of a four-cusped hypocycloid.

6. The legs of a variable right triangle lie along two fixed lines. If the area of the triangle remains constant, find the envelope of the hypotenuse.

7. Find the envelope of a circle which is always tangent to the axis of x and always has its centre on the parabola $y = x^2$.

8. What is the envelope of all the chords of a circle which are of a given length?

9. Find the envelope of the family of circles which pass through the origin and have their centres on the hyperbola $xy = 1$.

10. A straight line moves in such a way that the sum of its intercepts on two rectangular axes is constant. Find its envelope. Draw an accurate figure.

11. The streams of water in a fountain issue from the nozzle, which is small, in all directions, but with the same velocity, v_0 . Show that the form of the fountain is approximately a paraboloid of revolution.

2. Envelope of Tangents and Normals. Any curve may be regarded as the envelope of its tangents. Thus the equation of the tangent to the parabola

$$(11) \quad y^2 = 2mx$$

at the point (x_0, y_0) is

$$y - y_0 = \frac{m}{y_0} (x - x_0)$$

or

$$(12) \quad y = \frac{mx}{y_0} + \frac{y_0}{2}.$$

Hence the envelope of the lines (12), where y_0 is regarded as a parameter, must be the parabola (11), and the student can readily assure himself that this is the case.

The evolute of a curve was defined as the locus of the centres of curvature, and it was shown that the normal to the curve is tangent to the evolute. Hence the evolute is the envelope of the normals, and thus we have a new method for determining the evolute.

For example, the equation of the normal to the parabola

$$y = x^2$$

at the point (x_0, y_0) is

$$x - x_0 + 2x_0(y - y_0) = 0$$

or
$$x + 2x_0y - x_0 - 2x_0^3 = 0,$$

and we get at once as the envelope of this family of lines:

$$y = 3x_0^2 + \frac{1}{2}, \quad x = -4x_0^3,$$

or
$$(y - \frac{1}{2})^3 = \frac{27}{16}x^2.$$

EXERCISES

1. Obtain the equation of the evolute of the ellipse:

$$x = a \cos \phi, \quad y = b \sin \phi,$$

as the envelope of its normals.

2. Obtain the evolute of the cycloid:

$$x = a(\theta - \sin \theta), \quad y = a(1 - \cos \theta).$$

3. Obtain the coordinates (x_1, y_1) of any point on the envelope of the normals to the curve $y = f(x)$:

$$x - x_0 + f'(x_0)(y - y_0) = 0,$$

and show that the result agrees with the formulas of Chap. VII, § 3.

3. Caustics. When rays of light that are nearly parallel fall on the concave side of a napkin ring or a water glass, a portion of the table cloth is illuminated. Let us determine the equation of the boundary.



FIG. 88

Suppose we have a narrow semicircular band, on the polished concave side of which a bundle of parallel rays fall. The rays are reflected at the same angle with the normal as the angle of incidence, and so we wish to find the envelope of the reflected rays. Take the radius of the band as 1. Then the equation of the reflected ray is

$$(13) \quad y - \sin \theta = \tan 2\theta(x - \cos \theta).$$

To get the envelope of the family, we differentiate with respect to θ :

$$\begin{aligned} -\cos \theta &= 2 \sec^2 2\theta (x - \cos \theta) + \tan 2\theta \sin \theta, \\ 2x &= 2 \cos \theta - \cos^2 2\theta \cos \theta - \cos 2\theta \sin 2\theta \sin \theta \\ &= 2 \cos \theta - \cos 2\theta (\cos 2\theta \cos \theta + \sin 2\theta \sin \theta) \\ &= 2 \cos \theta - \cos 2\theta \cos \theta, \end{aligned}$$

or:
$$x = \frac{1}{2}(3 \cos \theta - 2 \cos^3 \theta).$$

Substituting this value of x in (13) we get:

$$y = \sin^3 \theta.$$

But these are the equations of an epicycloid of two cusps, *i.e.* the one in which $a = 2b$, $b = \frac{1}{4}$, p. 150, (9).

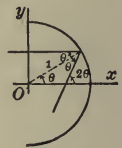

FIG. 89

EXERCISE

If the band is a complete circle and a point-source of light is situated on the circumference, draw accurately a figure showing the reflected rays and prove that their envelope is a cardioid.

CHAPTER XVIII

DOUBLE INTEGRALS

1. Volume of Any Solid. In Chap. IX we have computed the volumes of a number of solids more or less irregular in shape. It is not difficult to generalize and obtain a method for computing the volume of any solid whatsoever by integration. A suggestive example is given by a problem of naval architecture, — that of determining the displacement of a ship. Here, the plans of the ship, drawn on paper to scale, furnish the areas of cross-sections which are near enough together so that a good approximation for the volume of the ship between two successive cross-sections may be obtained by considering this part of the ship as a cylinder whose base is one of the cross-sections and whose altitude is the distance to the next one.*

Let us now conceive a solid of arbitrary shape. Assume a line in space, whose direction is taken at pleasure, and cut the solid by a variable plane perpendicular to this line; see Fig. 90. Denote the distance of an arbitrary point on the line from a fixed point of the line by x . The area of the cross-section made by the above plane is a function of x , which we will denote by $A(x)$, or simply A . Let the minimum x corresponding to one of the above planes be $x = a$, the maximum, $x = b$. Divide the interval from a to b into n equal parts by the points

* It is possible to approximate to the volume still better by means of more elaborate formulas (Simpson's Rule), but this simplest approximation is more suggestive for our present purposes.

$x_0 = a, x_1, \dots, x_n = b$ and pass planes through these points perpendicular to the line. Then the volume in question is given approximately by the sum :

$$A(x_0) \Delta x + A(x_1) \Delta x + \dots + A(x_{n-1}) \Delta x,$$

and the limit of this sum, when n becomes infinite, is exactly the volume sought :

$$(1) \quad V = \int_a^b A dx.$$

Example. To compute the volume of the ellipsoid :

$$\frac{x^2}{a^2} + \frac{y^2}{b^2} + \frac{z^2}{c^2} = 1.$$

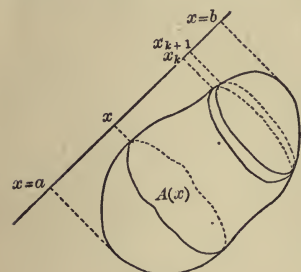

FIG. 90

Here, the cross-section made by an arbitrary plane $x = x'$ is the ellipse

$$\frac{y^2}{b^2} + \frac{z^2}{c^2} = 1 - \frac{x'^2}{a^2},$$

i.e.

$$\frac{y^2}{b^2 \left(1 - \frac{x'^2}{a^2}\right)} + \frac{z^2}{c^2 \left(1 - \frac{x'^2}{a^2}\right)} = 1.$$

Its semiaxes have respectively the lengths

$$b \sqrt{1 - \frac{x'^2}{a^2}}, \quad c \sqrt{1 - \frac{x'^2}{a^2}},$$

and hence its area is, the accents being suppressed :

$$A = \pi bc \left(1 - \frac{x^2}{a^2}\right).$$

The volume V is, therefore,

$$\begin{aligned} V &= \pi bc \int_{-a}^a \left(1 - \frac{x^2}{a^2}\right) dx \\ &= \pi bc \left(x - \frac{x^3}{3a^2}\right) \Big|_{-a}^a = \frac{4}{3} \pi abc. \end{aligned}$$

2. Two Expressions for the Volume under a Surface; First Method. We turn now to the problem of computing the volume under any surface,

$$(2) \quad z = f(x, y).$$

Given, namely, a region S of the (x, y) -plane and a function $f(x, y)$, single valued and continuous throughout S ; for the present we will assume, furthermore, that f is positive. Erect a cylindrical column on S as base and consider

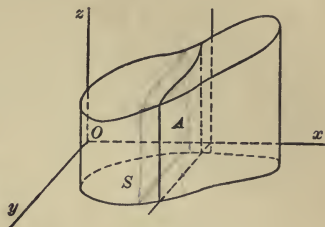

FIG. 91

the volume of the part of this column capped by the surface (2). It is this volume V that we wish to compute.

Our first method is that of § 1. We cut the solid by a plane $x = x'$ and compute the area A of this cross-section. Now A is merely the area under the curve

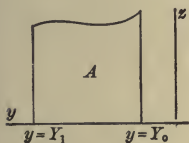

FIG. 92

$$z = \phi(y) = f(x', y) \quad (x', \text{constant})$$

between the ordinates corresponding to the abscissas $y = Y_0$ and $y = Y_1$. Hence

$$A = \int_{Y_0}^{Y_1} f(x', y) dy.$$

Dropping the accent, which has now served its purpose, we have:

$$(3) \quad A(x) = \int_{Y_0}^{Y_1} f(x, y) dy,$$

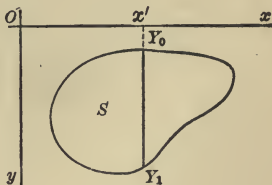

FIG. 93

where we must remember that x is constant, y being the variable of integration, and that Y_0 and Y_1 are functions of x .

It remains only to integrate A with respect to x between the limits $x = a$ and $x = b$, where a is the smallest abscissa

that any point in S has, and b is the largest. We thus obtain:

$$V = \int_a^b A(x) dx.$$

This last integral is commonly written in either of the forms: *

$$\int_a^b dx \int_{Y_0}^{Y_1} f(x, y) dy \quad \text{or} \quad \int_a^b \int_{Y_0}^{Y_1} f(x, y) dy dx.$$

It is called the *iterated integral* of $f(x, y)$ (not the double integral; the latter will be explained later), since it is the result of two ordinary integrations performed in succession.

Instead of integrating first with regard to y and then with regard to x , we might have reversed the order, integrating first with regard to x . We should thus obtain the formula:

$$V = \int_a^B dy \int_{x_0}^{x_1} f(x, y) dx.$$

For example, let us compute the volume cut off from the paraboloid:

$$z = 1 - \frac{x^2}{4} - \frac{y^2}{9}$$

by the (x, y) -plane. Since the surface is obviously symmetric with respect both to the (x, z) and the (y, z) planes, it is sufficient to compute the part of the volume that lies in the first octant, and then multiply the result by 4. To get A we have

* Another form sometimes employed is to be avoided, namely:

$$\int_a^b \int_{Y_0}^{Y_1} f(x, y) dx dy.$$

The second form given in the text is to be thought of as an abbreviation for

$$\int_a^b \left\{ \int_{Y_0}^{Y_1} f(x, y) dy \right\} dx.$$

to hold x fast, *i.e.* to cut the solid by the plane $x = x'$, and compute the area of the section. This is the area under the curve

$$z = \phi(y) = 1 - \frac{x'^2}{4} - \frac{y^2}{9},$$

the limits of integration being determined as follows. The (x, y) plane, whose equation is $z = 0$, cuts the surface in the ellipse

$$0 = 1 - \frac{x^2}{4} - \frac{y^2}{9},$$

and the region S is the part of this ellipse lying in the first quadrant. The segment of the line $x = x'$ which lies within S has for its minimum ordinate $Y_0 = 0$, for its maximum Y_1 , where

$$0 = 1 - \frac{x'^2}{4} - \frac{Y_1^2}{9}, \quad Y_1 = \frac{3}{2} \sqrt{4 - x'^2}.$$

Thus

$$\begin{aligned} A &= \int_0^{Y_1} \left(1 - \frac{x'^2}{4} - \frac{y^2}{9}\right) dy = \left(1 - \frac{x'^2}{4}\right)y - \frac{y^3}{27} \Big|_0^{Y_1} = \left\{1 - \frac{x'^2}{4} - \frac{Y_1^2}{27}\right\} Y_1 \\ &= \frac{1}{4}(4 - x'^2) \sqrt{4 - x'^2}. \end{aligned}$$

Hence, dropping the accent, we get :

$$A = \frac{1}{4}(4 - x^2)^{\frac{3}{2}}.$$

Finally, integrating A from the smallest x in S to the largest, we have (see *Tables*, No. 137) :

$$\begin{aligned} &\frac{1}{4} \int_0^2 (4 - x^2)^{\frac{3}{2}} dx = \\ &\frac{1}{16} \left[x(4 - x^2)^{\frac{3}{2}} + 6x \sqrt{4 - x^2} + 24 \sin^{-1} \frac{x}{2} \right]_0^2 = \frac{3\pi}{4}, \end{aligned}$$

and so the total volume is $3\pi = 9.42$.

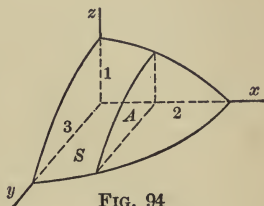

FIG. 94

EXERCISES

1. A round hole of radius unity is bored through the solid just considered, the axis of the hole being the axis of z . Find the volume removed.

2. Compute the volume of a cylindrical column standing on the area common to the two parabolas

$$x = y^2, \quad y = x^2$$

as base and cut off by the surface

$$z = 12 + y - x^2.$$

3. Work each of the foregoing examples, integrating first with regard to x and then with regard to y .

3. Continuation. Second Method. Another way of finding the above volume is as follows. Divide the region S up into small pieces, called *elements of area*, of arbitrary shape, and denote the area of any one of them by ΔS_k . Let (x_k, y_k) be an arbitrary point of the k th element. Construct a cylinder on this element as base and of height $f(x_k, y_k)$; see Fig. 102. The volume of this column is

$$f(x_k, y_k) \Delta S_k.$$

Consider now the totality of such columns. They form a solid whose volume,

$$(4) \quad \sum_{k=0}^{n-1} f(x_k, y_k) \Delta S_k,$$

differs only slightly from the volume V we wish to compute. As n grows larger and larger, the maximum diameter of each of the elementary areas approaching 0 as its limit, it is clear that the limit of (4) is V :

$$(5) \quad V = \lim_{n \rightarrow \infty} \sum_{k=0}^{n-1} f(x_k, y_k) \Delta S_k.$$

This is the second expression for the volume we set out to obtain.

We remark that it is not important that the elementary areas just fill out the region S . Thus we might divide the plane by parallels to the coordinate axes into rectangles whose sides are of length Δx and Δy , and then take as the elementary areas (a) all the rectangles that lie wholly within S ; or (b) all those just mentioned and in addition such as contain at least one point of the boundary of S in their interior or on their boundary; or (c) any set intermediate between (a) and (b). In each case the sum (4) would clearly have as its limit the volume V .

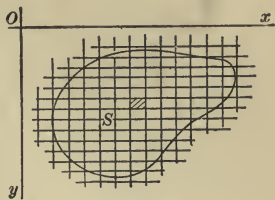

FIG. 95

4. The Fundamental Theorem of the Integral Calculus. Just as in Chap. IX, § 2, we equated the two expressions for the area under a curve to each other and thus obtained an analytical theorem regarding limits, so here we equate the two expressions just found for the volume under a surface and thereby deduce a corresponding theorem for functions of two independent variables.

FUNDAMENTAL THEOREM OF THE INTEGRAL CALCULUS. Let $f(x, y)$ be a continuous function of x and y throughout a region S of the (x, y) -plane. Divide this region up into n pieces of area $\Delta S_0, \Delta S_1, \dots, \Delta S_{n-1}$ and form the sum:

$$f(x_0, y_0) \Delta S_0 + f(x_1, y_1) \Delta S_1 + \dots + f(x_{n-1}, y_{n-1}) \Delta S_{n-1},$$

where (x_k, y_k) is any point of the k -th elementary area. If n now be allowed to increase without limit, the maximum diameter of each of the elements of area approaching 0 as its limit, this sum will approach a limit which is given by the formula:

$$\int_a^b dx \int_{y'}^{y''} f(x, y) dy \quad \text{or} \quad \int_a^{\beta} dy \int_x^{x''} f(x, y) dx,$$

where the limits of integration are determined as described in § 2.

Expressed as a formula the theorem is as follows :

$$(6) \quad \lim_{n \rightarrow \infty} \sum_{k=0}^{n-1} f(x_k, y_k) \Delta S_k = \int_a^b dx \int_{y'}^{y''} f(x, y) dy = \int_a^{\beta} dy \int_{x'}^{x''} f(x, y) dx.$$

DEFINITION OF THE DOUBLE INTEGRAL. The limit that stands in the first member of (6) is called the *double integral* of the function f taken over the region S , and is written as follows :

$$(7) \quad \lim_{n \rightarrow \infty} \sum_{k=0}^{n-1} f(x_k, y_k) \Delta S_k = \iint_S f dS.$$

It is independent of the particular system of coordinates used, and applies equally well, whether cartesian or polar coordinates are employed. The iterated integral, on the other hand, has been obtained at present only for cartesian coordinates.

The double integral is also written in the form :

$$\iint f dx dy \quad \text{or} \quad \iint f r dr d\theta,$$

the latter form referring to polar coordinates (cf. § 7).

The Fundamental Theorem can now be written as follows :

$$(6') \quad \iint_S f dS = \int_a^b dx \int_{y'}^{y''} f(x, y) dy,$$

with a similar formula when the first integration is performed with respect to x .

We have hitherto assumed that the boundary of S is cut by a parallel to the axis of y at most in two points. If this is not the case, there is still no difficulty in the definition of the double integral. For the purpose of evaluating the same, however, by means of the iterated integral, S may be divided up into regions, for each of which

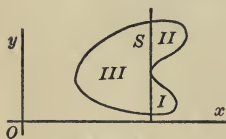

FIG. 96

the above is true (see Fig. 96), and then, inasmuch as the double integral extended over all S is evidently equal to the sum of

the double integrals of the same function extended over the different divisions of S , it is sufficient to compute the double integral for each of these divisions by means of (6).

We have further assumed that the function f is positive in S . If it were negative, the same reasoning would still hold, only both expressions for V would yield the negative value of the volume. They would, therefore, still be equal to each other. If, finally, f changes sign in S , divide S up into regions in which f is positive and those in which it is negative. The Fundamental Theorem holds for each region by itself, and so it holds for the combined region.

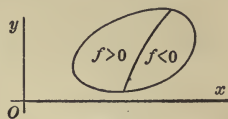

FIG. 97

EXERCISE

Show that the abscissa of the centre of gravity of a homogeneous plane area is given by the formula:

$$\bar{x} = \frac{\iint_S x dS}{A}.$$

5. Moments of Inertia. Consider the moment of inertia of a plane lamina of variable density ρ about a point O in its plane. In accordance with Chap. IX, § 14, we divide the lamina up into small pieces, of area ΔS_k and of mass ΔM_k , and form the sum:

$$\sum_{k=0}^{n-1} r_k^2 \Delta M_k,$$

where r_k is the distance of a point (x_k, y_k) of the k th elementary area from O . We can write the mass ΔM_k as the product of the corresponding area ΔS_k by the average density of this piece, $\bar{\rho}_k$:

$$\Delta M_k = \bar{\rho}_k \Delta S_k.$$

Hence

$$I = \lim_{n \rightarrow \infty} \sum_{k=0}^{n-1} \bar{\rho}_k r_k^2 \Delta S_k.$$

If the first factor, $\bar{\rho}_k$, in each term is the value of ρ in the particular point (x_k, y_k) , then the limit of this sum is by definition the double integral

$$\iint_S \rho r^2 dS.$$

If, however, this is not the case, we need only to apply Duhamel's Theorem, setting

$$\alpha_k = \rho_k r_k^2 \Delta S_k, \quad \beta_k = \rho_k r_k^2 \Delta S_k,$$

where ρ_k is the value of ρ in (x_k, y_k) .

Then
$$\lim_{n \rightarrow \infty} \frac{\beta_k}{\alpha_k} = 1,$$

and hence in all cases

$$(8) \quad I = \iint_S \rho r^2 dS.$$

Example 1. The density of a rectangle is proportional to the square of the distance from one corner. Find its moment of inertia about that corner.

Here,
$$\rho = \lambda r^2,$$

and hence
$$I = \lambda \iint_S r^4 dS;$$

$$\begin{aligned} \iint_S r^4 dS &= \int_0^a dx \int_0^b (x^4 + 2x^2y^2 + y^4) dy = \frac{1}{5}a^5b + \frac{2}{9}a^3b^3 + \frac{1}{5}ab^5; \\ I &= \frac{\lambda ab}{45} (9a^4 + 10a^2b^2 + 9b^4). \end{aligned}$$

The mass of any lamina is easily seen to be

$$(9) \quad M = \iint_S \rho dS.$$

In the present case, therefore,

$$M = \lambda \iint_S r^2 dS = \frac{\lambda ab}{3} (a^2 + b^2)$$

Hence
$$I = M \frac{9a^4 + 10a^2b^2 + 9b^4}{15(a^2 + b^2)}.$$

It is sometimes more convenient to use the formulation of the moment of inertia as a double integral, even when the density of the lamina is constant, *e.g.*:

Example 2. To find the moment of inertia of a triangular lamina of constant density about a vertex.

Here,

$$I = \rho \int_s \int r^2 dS;$$

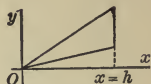

FIG. 98

$$\int_s \int r^2 dS = \int_0^h dx \int_{y'}^{y''} (x^2 + y^2) dy,$$

$$y' = l'x, \quad y'' = l''x.$$

$$\therefore I = \rho [l'' - l' + \frac{1}{3}(l''^3 - l'^3)] \frac{h^4}{4} = \frac{Mh^2}{6} (3 + l'^2 + l'l'' + l''^2).$$

EXERCISES

1. Determine by double integration the moment of inertia of a right triangle of constant density about the vertex of the right angle.

Ans. $\frac{M(a^2 + b^2)}{6}$.

2. Compute the moment of inertia about the focus of the segment of a parabola cut off by the latus rectum.

3. Show that the moment of inertia of a lamina about the axis of *y* is

$$I = \int_s \int \rho x^2 dS.$$

4. Find the moment of inertia about the axis of *y* of a uniform lamina bounded by the parabola $y^2 = 4ax$, the line $x + y = 3a$, and the axis of *x*. Work the problem both ways, integrating first with regard to *x*, then with regard to *y*; and then in the opposite order.

Ans. $I = \frac{46\rho a^4}{7}$.

6. Theorems of Pappus. THEOREM I. *If a closed curve rotate about an external axis lying in its plane, the volume of the ring thus generated is the same as that of a cylinder whose base is the region S enclosed by the curve and whose altitude is the distance through which the centre of gravity of S has travelled:*

$$(10) \quad V = 2\pi h \cdot A,$$

where h denotes the distance of the centre of gravity of S from the axis, and A , the area of S .

We will confine ourselves to the case that the boundary curve is met at most in two points by a parallel to the axis of rotation, which we will take as the axis of ordinates. Divide the area into strips of breadth Δx by parallels to the axis of y , and approximate to the volume generated by the k th strip by means of the volume generated by a rectangle with the left-hand boundary of this strip for one of its sides and with base Δx .* This latter volume can be computed at once as the difference between two cylinders of revolution, and is $\pi x_{k+1}^2(y''_k - y'_k) - \pi x_k^2(y''_k - y'_k) = 2\pi x_k(y''_k - y'_k)\Delta x + \pi(y''_k - y'_k)\Delta x^2$, $y' = \phi(x)$ being the equation of the lower boundary, and $y'' = f(x)$ that of the upper one. Hence

$$V = \lim_{n \rightarrow \infty} \sum_{k=0}^{n-1} \{2\pi x_k(y''_k - y'_k)\Delta x + \pi(y''_k - y'_k)\Delta x^2\}.$$

This last expression can be simplified by Duhamel's Theorem, and thus

$$V = \lim_{n \rightarrow \infty} \sum_{k=0}^{n-1} 2\pi x_k(y''_k - y'_k)\Delta x = 2\pi \int_a^b x(y'' - y')dx.$$

Recalling the result of Ex. 4, p. 174, we see that the value of this integral is $\bar{x}A = hA$, and this completes the proof.

If the curve rotates only through an angle Θ instead of completely round the axis, we have merely to replace 2π by Θ .

* The student should draw the requisite figure.

Finally, the form of the proof is somewhat simplified by means of double integrals, the above restriction on the boundary, as well as the use of Duhamel's Theorem, being then unnecessary. We have at once:

$$V = \lim \sum 2\pi x \Delta S = 2\pi \int_s \int x dS, \quad \bar{x} = \frac{\int_s \int x dS}{A}.$$

THEOREM II. *If a plane curve, closed or not closed, rotate about an axis not cutting it and lying in its plane, the area of the surface thus generated is the same as that part of the cylindrical surface having the given curve as generatrix, which lies between two parallel planes whose distance apart is the distance traversed by the centre of gravity of the given curve:*

$$S = 2\pi h \cdot l \quad \text{or} \quad \odot h \cdot l.$$

The proof is similar to that of the first theorem, and is left as an exercise for the student.

7. Polar Coordinates. We have computed the volume V under the surface $z=f(x, y)$ by iterated integration, using cartesian coordinates. Let us now compute the same volume, using polar coordinates. To do this we divide the solid up into thin wedge-shaped slabs (the slab not extending in general clear to the edge of the wedge) by means of n equally spaced planes through the axis of z : $\theta = \theta_0 = \alpha, \theta_1, \dots, \theta_n = \beta$, and approximate to the volume of the k -th slab, ΔV_k , as follows. Let A_k be the area of the section of the plane $\theta = \theta_k$ with the solid, and let this section rotate about the axis of z through the angle $\Delta\theta$. Then, by the first theorem of Pappus, § 6, the volume generated is $\Delta\theta \cdot h_k A_k$, and the sum of such volumes,

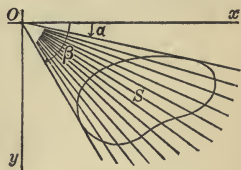

FIG. 99

$$\sum_{k=0}^{n-1} h_k A_k \Delta\theta,$$

is a good approximation for V . In fact, when we visualize the totality of these pieces, we see that the volume of the solid thus obtained approaches V as its limit, when $n = \infty$. Hence

$$(11) \quad V = \lim_{n \rightarrow \infty} \sum_{k=0}^{n-1} h_k A_k \Delta\theta = \int_a^{\beta} h A d\theta.$$

Furthermore, let us consider the product hA corresponding to the cross-section made by an arbitrary plane $\theta = \theta'$. Writing the equation of the surface in the form

$$z = f(x, y) = F(r, \theta)$$

and recalling the general formula for the centre of gravity :

$$\bar{x} = \frac{\int_a^b xy dx}{A},$$

we have here to set

$$x = r, \quad \bar{x} = h, \quad y = z = F(r, \theta'), \quad a = r', \quad b = r'',$$

and we thus obtain :

$$hA = \int_{r'}^{r''} r F(r, \theta') dr.$$

Substituting this last expression in (11), we get the final formula :

$$V = \int_a^{\beta} d\theta \int_{r'}^{r''} r F(r, \theta) dr,$$

and hence the

THEOREM :

$$(12) \quad \iint_S F(r, \theta) dS = \int_a^{\beta} d\theta \int_{r'}^{r''} r F(r, \theta) dr.$$

The first integration is performed on the supposition that θ is held fast and that r varies from the smallest value r' , which it has in S corresponding to the given value of θ to the largest value, r'' .

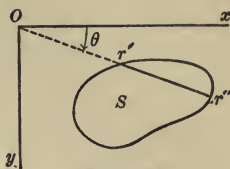

FIG. 100

The Inverse Order of Integration. If instead of using the planes $\theta = \theta_0, \theta_1, \dots, \theta_n$ we had divided the solid up by the cylinders $r = r_0 = a, r_1, \dots, r_n = b$, we should have been led to the result:

$$(13) \quad \iint_S F(r, \theta) dS = \int_a^b dr \int_{\theta'}^{\theta''} rF(r, \theta) d\theta.$$

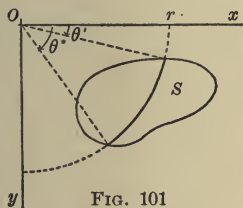

FIG. 101

Here, the first integration is performed on the supposition that r is held fast and that θ varies from the smallest value, θ' , which it has in S corresponding to the given value of r to the largest value, θ'' .

Example. To find the moment of inertia of a uniform circular disc about its centre. Here

$$I = \rho \iint_S r^2 dS = \rho \int_0^{2\pi} d\theta \int_0^a r^3 dr = \rho \cdot 2\pi \cdot \frac{a^4}{4},$$

and hence

$$I = Ma^2/2.$$

This problem we have solved before by single integration. The solution by double integration is simpler in form, though in substance the two solutions are closely related.

EXERCISES

1. The density of a circular disc is proportional to the distance from the centre. Find the radius of gyration of the disc about its centre.

Ans. $a\sqrt{\frac{3}{5}}$.

2. Determine the moment of inertia about the focus of the segment of the parabola:

$$r = \frac{m}{1 - \cos \theta}$$

bounded by the latus rectum.

3. The density of a square lamina is proportional to the distance from one corner. Find its moment of inertia about this corner.

4. Find the moment of inertia about the origin of the part of the first quadrant bounded by two successive coils of the equiangular spiral

$$r = e^\theta,$$

the inner boundary going through the point $\theta = 0, r = 1$.

5. Find the moment of inertia of the lemniscate:

$$r^2 = a^2 \cos 2\theta,$$

about the point $r = 0$.

6. Show that the abscissa of the centre of gravity of any plane area is given by the formula:

$$\bar{x} = \frac{\int_S \int_S \rho x dS}{M}.$$

7. Find the centre of gravity of the lemniscate of question 5.

8. Show that the area of any plane region S is expressed by the integrals:

$$A = \int_S \int_S dx dy = \int_S \int_S r dr d\theta.$$

9. Find the area bounded by the curve

$$\theta = \sin r$$

and the portion of the axis of x between the origin and the point $x = \pi$.

Ans. π .

8. Areas of Surfaces. We have determined the area under a plane curve and the lateral area of a surface of revolution by means of simple integrals. The general problem of finding the area of any curved surface is solved by double integration.

Let the equation of the surface be

$$z = f(x, y)$$

and let the projection on the x, y plane of the part \mathcal{S} of this surface whose area A is to be computed, be the region S . Divide S up into elementary areas and erect on the perimeter of each as generatrix a cylindrical surface. By means of these cylinders the surface \mathcal{S} is divided into elementary pieces, of area ΔA_k , ($k = 0, 1, \dots, n - 1$), and we next consider how we may approximate to these partial areas. Evidently this may be done by constructing the tangent plane at a point (x_k, y_k, z_k) of the k -th elementary area and computing the area cut out of this plane by the cylinder in question. Now the orthogonal cross-section of this cylinder is of area ΔS_k , and hence the oblique section will have the area

$$\Delta S_k \sec \gamma_k,$$

where γ_k is the angle between the planes, or between their normals. The desired approximation is thus seen to be

$$\sum_{k=0}^{n-1} \Delta S_k \sec \gamma_k,$$

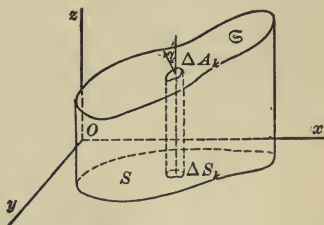

FIG. 102

and consequently A is equal to the limit of this sum, or*

* It is a fundamental principle of elementary geometry to refer all geometrical truth back directly to the definitions and axioms. What are the axioms on which this formula depends? The answer is: *The formula itself is an axiom.* The justification for this axiom is the same as for any other physical law, namely, that the physical science, here geometry, built on it is in accord with experience.

$$(14) \quad A = \int_s \int \sec \gamma \, dS.$$

The angle γ is the angle between the normal to the surface and the axis of z . Hence by Chap. XV, § 1:

$$(15) \quad \sec \gamma = \sqrt{1 + \frac{\partial z^2}{\partial x^2} + \frac{\partial z^2}{\partial y^2}}.$$

If the equation of the surface is written in the form

$$F(x, y, z) = 0,$$

we have

$$(16) \quad \sec \gamma = \frac{\sqrt{\left(\frac{\partial F}{\partial x}\right)^2 + \left(\frac{\partial F}{\partial y}\right)^2 + \left(\frac{\partial F}{\partial z}\right)^2}}{\left|\frac{\partial F}{\partial z}\right|}.$$

Example. Two equal cylinders of revolution are tangent to each other externally along a diameter of a sphere, whose radius is double that of the cylinders. Find the area of the surface of the sphere interior to the cylinders.

It is sufficient to compute the area in the first octant and multiply the result by 8. We have to extend the integral (14) over the region S indicated in Fig. 104. Here,

$$x^2 + y^2 + z^2 = a^2,$$

and by (16)

$$\sec \gamma = \frac{a}{z} = \frac{a}{\sqrt{a^2 - r^2}}, \quad r^2 = x^2 + y^2.$$

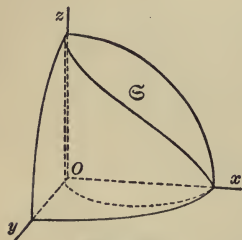

FIG. 103

Since the integrand, $\sec \gamma$, depends in a simple way on r , it will probably be well to use polar coordinates in the iterated integral. We have, then:

$$\frac{1}{8} A = \int_s \int \sec \gamma \, dS = \int_0^{\frac{\pi}{2}} d\theta \int_0^{a \cos \theta} \frac{ar \, dr}{\sqrt{a^2 - r^2}},$$

$$\int_0^{a \cos \theta} \frac{ar dr}{\sqrt{a^2 - r^2}} = -a \sqrt{a^2 - r^2} \Big|_0^{a \cos \theta} = a^2(1 - \sin \theta),$$

$$\therefore \frac{1}{8} A = a^2 \int_0^{\frac{\pi}{2}} (1 - \sin \theta) d\theta = a^2 \left(\frac{\pi}{2} - 1 \right),$$

$$A = 4\pi a^2 - 8a^2.$$

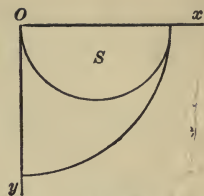

FIG. 104

Objection may be raised to the foregoing solution on the ground that the integrand, $\sec \gamma = a/\sqrt{a^2 - r^2}$, does not remain finite throughout S , but becomes infinite at the point $\theta = 0$, $r = a$. We may avoid this difficulty by computing first only so much of the area as lies over the angle $\alpha \leq \theta \leq \pi/2$, where the positive quantity α is chosen arbitrarily small. The value of this area is

$$a^2 \int_{\alpha}^{\frac{\pi}{2}} (1 - \sin \theta) d\theta = a^2 \left(\frac{\pi}{2} - \alpha + \cos \alpha \right),$$

and its limit, when α approaches 0, is

$$a^2 \left(\frac{\pi}{2} - 1 \right).$$

EXERCISES

1. A cylinder is constructed on a single loop of the curve $r = a \cos n\theta$ as generatrix, its elements being perpendicular to the plane of this curve. Determine the area of the portion of the surface of the sphere $x^2 + y^2 + z^2 = 2az$ which the cylinder intercepts.

Ans. $\frac{2(\pi - 2)a^2}{n}$

2. Compute the moment of inertia about the axis of z of the surface whose area was determined above in the text.

3. A square hole is cut through a sphere, the axis of the hole

coinciding with a diameter of the sphere. Find the area of the surface removed.

$$\text{Ans. } 16ab \sin^{-1} \frac{b}{\sqrt{a^2 - b^2}} - 8a^2 \sin^{-1} \frac{b^2}{a^2 - b^2}.$$

4. Determine the area of the surface

$$z = xy$$

included within the cylinder

$$x^2 + y^2 = a^2.$$

5. A cylindrical surface is erected on the curve $r = \theta$ as generatrix, the elements being perpendicular to the plane of this curve. Find the area of the portion of the surface

$$z = xy$$

which is bounded by the y, z plane and so much of the cylindrical surface as corresponds to $0 \leq \theta \leq \pi/2$.

9. **Cylindrical Surfaces.** If the surface \mathfrak{S} is a cylinder, the area can be expressed explicitly as a simple integral. Let the elements of the cylinder be parallel to the axis of y . The equation of the surface then becomes:

$$z = f(x).$$

Hence
$$A = \int_s \int \sec \gamma \, dS = \int_a^b dx \int_{y'}^{y''} \sqrt{1 + f'(x)^2} \, dy,$$

$$(17) \quad A = \int_a^b \sqrt{1 + f'(x)^2} (y'' - y') \, dx.$$

EXERCISES

1. Two cylinders of revolution, of equal radii, intersect, their axes cutting each other at right angles. Show that the total area of the surface of the solid included within these cylinders is $16a^2$.

2. Obtain formula (17) directly, without the use of double integrals.

3. Write out formula (17) when the elements of the cylinder are perpendicular (a) to the x, y plane; (b) to the y, z plane.

4. Show that the lateral area of that part of either of the cylinders discussed in the example of § 8 which is contained in the sphere is $4a^2$.

5. The area of a region S of the x, y plane may be written in the form :

$$A = \int_s \int dS = \int_a^b (y'' - y') dx = \int_a^b (x'' - x') dy.$$

By means of the last formula compute the area of the region common to the circle and the parabola :

$$x^2 + y^2 = 16a^2, \quad y^2 = 6ax.$$

6. Deduce from formula (14) the formula of Chap. IX, § 8, for the area of a surface of revolution :

$$A = 2\pi \int_a^b y \sqrt{1 + f'(x)^2} dx.$$

10. **Analytical Proof of the Fundamental Theorem. Cartesian Coordinates.** In the sum :

$$(18) \quad \sum_{k=0}^{n-1} f(x_k, y_k) \Delta S_k,$$

whose limit is the double integral

$$(19) \quad \int_s \int f dS,$$

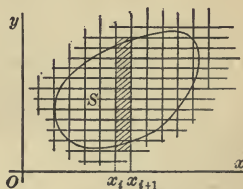

FIG. 105

we may choose as elementary areas rectangles with sides $\Delta x, \Delta y$, thus making $\Delta S_k = \Delta x \Delta y$, and then add all those terms together which correspond to rectangles lying in a column parallel to the axis of y . This partial sum can be represented as follows :

$$\Delta x \sum_{j=0}^{q-1} f(x_i, y_j) \Delta y,$$

where we have assigned new indices, i and j , to the coordinates of the point (x_k, y_k) , and where furthermore we have chosen the points (x_k, y_k) of this column so that they all have the same abscissa, x_i .

If, now, holding x_i and Δx fast, we allow q to increase without limit, Δy approaching 0 as its limit, we have

$$(20) \quad \Delta x \lim_{q=\infty} \sum_{j=0}^{q-1} f(x_i, y_j) \Delta y = \Delta x \int_{y'_i}^{y''_i} f(x_i, y) dy.$$

Next, we add all the limits of these columns together:

$$\sum_{i=0}^{p-1} \Delta x \int_{y'_i}^{y''_i} f(x_i, y) dy,$$

and allow p to increase without limit, Δx approaching 0. This gives

$$\lim_{p=\infty} \sum_{i=0}^{p-1} \Delta x \int_{y'_i}^{y''_i} f(x_i, y) dy = \int_a^b dx \int_{y'}^{y''} f(x, y) dy,$$

i.e. the iterated integral of the Fundamental Theorem.

This method of deduction is less rigorous than the former one, for we have not proven that we get the same result when we take the limit by columns and then take the limit of the sum of the columns, as when we allow all the ΔS_k 's to approach 0 simultaneously in the manner prescribed in the definition of the double integral.* It is nevertheless useful as giving us

* For a complete analytical treatment of the subject of this paragraph along the lines here indicated, which in point of elegance and rigor leaves nothing to be desired, see Goursat-Hedrick, *Mathematical Analysis*, Chap. VI.

additional insight into the structure of the iterated integral, for it enables us to think of the first integration as corresponding to a *summation of the elements in (18) by columns*, and of the second integration as corresponding to the *summation of these columns*. Moreover, when we come to polar coordinates in the next paragraph, it helps to explain and make evident the limits of integration.

11. Continuation; Polar Coordinates. Let the region S be divided up into elementary areas by the circles $r = r_i$, $r_{i+1} - r_i = \Delta r$, and the straight lines $\theta = \theta_j$, $\theta_{j+1} - \theta_j = \Delta \theta$. Then

$$\Delta S_k = r_k \Delta r \Delta \theta + \frac{1}{2} \Delta r^2 \Delta \theta,$$

and hence, in taking the limit of the sum (18), ΔS_k may, by Duhamel's Theorem, be replaced by $r_k \Delta r \Delta \theta$. Writing

$$f(x, y) = F(r, \theta)$$

we have, therefore,

$$\int_S \int f dS = \lim_{n \rightarrow \infty} \sum_{k=0}^{n-1} F(r_k, \theta_k) r_k \Delta r \Delta \theta.$$

In order to evaluate this latter limit, we may replace (r_k, θ_k) by (r_i, θ_j) and, holding θ_j fast, add together those terms that correspond to elementary areas lying in the angle between the rays $\theta = \theta_j$ and $\theta = \theta_{j+1}$, thus getting:

$$\Delta \theta \sum_{i=0}^{p-1} F(r_i, \theta_j) r_i \Delta r.$$

The limit of this sum, as $p = \infty$, is

$$\Delta \theta \int_{r_j}^{r_j''} F(r, \theta_j) r dr.$$

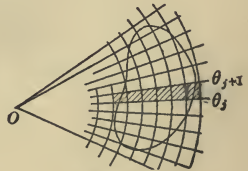

FIG. 106

Next, add all the limits thus obtained for the successive elementary angles together and take the limit of this sum. We thus get

$$\lim_{q \rightarrow \infty} \sum_{j=0}^{q-1} \Delta\theta \int_{r'_j}^{r''_j} F(r, \theta_j) r dr = \int_a^\beta d\theta \int_r^{r''} F(r, \theta) r dr,$$

i.e. the first iterated integral, (12), of § 7.

If on the other hand we hold r_i fast and add the terms that correspond to elementary areas lying in the circular ring bounded by the radii $r = r_i$ and $r = r_{i+1}$, we get

$$\Delta r \sum_{j=0}^{q-1} F(r_i, \theta_j) r_i \Delta\theta,$$

and the limit of this sum, when $q = \infty$, is

$$\Delta r \int_{\theta'_i}^{\theta''_i} F(r_i, \theta) r_i d\theta = r_i \Delta r \int_{\theta'_i}^{\theta''_i} F(r_i, \theta) d\theta.$$

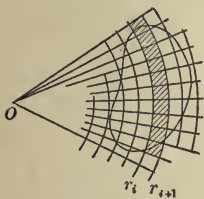

FIG. 107

Adding all these latter limits together and taking the limit of this sum, we have:

$$\lim_{p \rightarrow \infty} \sum_{i=0}^{p-1} r_i \Delta r \int_{\theta'_i}^{\theta''_i} F(r_i, \theta) d\theta = \int_a^b r dr \int_{\theta'}^{\theta''} F(r, \theta) d\theta,$$

i.e. the second iterated integral, (13), of § 7.

12. Surface Integrals. The extension of the conception of the double integral from a plane region S to a curved surface \mathfrak{S} is immediate. Let a function f be given, defined at each point of \mathfrak{S} , and let it be continuous over \mathfrak{S} . Let \mathfrak{S} be divided up into a large number of small areas, — *elementary areas*, — $\Delta\mathfrak{S}_k$, and let f_k be the value of f at an arbitrary point of $\Delta\mathfrak{S}_k$. Form the sum:

$$\sum_{k=0}^{n-1} f_k \Delta\mathfrak{S}_k.$$

The limit of this sum when n grows larger and larger is the *surface integral of f over the region \mathfrak{S}* :

$$\lim_{n \rightarrow \infty} \sum_{k=0}^{n-1} f_k \Delta\mathfrak{S}_k = \int_{\mathfrak{S}} \int f d\mathfrak{S}.$$

EXERCISE

Show that the volume of a closed surface is given by the surface integral:

$$V = \frac{1}{3} \int_{\mathcal{S}} r \cos \phi \, d\mathcal{S},$$

where r denotes the distance of a variable point P of the surface from a fixed point O of space and ϕ is the angle that the outer normal of the surface at P makes with the line OP produced.

EXERCISES

1. Find the volume cut out of the first octant by the cylinders

$$z = 1 - x^2, \quad x = 1 - y^2.$$

Ans. $\frac{1}{3}\frac{8}{5}$.

2. Compute the value of the integral:

$$\int_S \int e^{x^2+y^2} \, dS,$$

extended over the interior of the circle

$$x^2 + y^2 = 1.$$

Ans. 5.40.

3. Evaluate

$$\int_S \int (x^2 - 3ay) \, dS,$$

where S is a square with its vertices on the coordinate axes, the length of its diagonal being $2a$.

Ans. $\frac{1}{3}a^4$.

4. Express as an iterated integral in polar coordinates the double integral

$$\int_S \int f \, dS,$$

extended over a right triangle having an acute angle in the pole. Give both orders of integration.

5. Express the iterated integral

$$\int_{-\frac{\pi}{2}}^{\frac{\pi}{2}} d\theta \int_0^{2a \cos \theta} f r dr$$

as a double integral, and state over what region the latter is extended.

6. The same for

$$(a) \int_{\beta}^{\frac{\pi}{2}} d\theta \int_0^{b \csc \theta} f r dr;$$

$$(b) \int_0^{2a} dy \int_{\frac{y^2}{2a}}^{\sqrt{2ay}} f dx.$$

7. Change the order of integration in the following integrals:

$$(a) \int_0^1 dx \int_{x^2}^1 f(x, y) dy;$$

$$(b) \int_0^a dy \int_{\sqrt{a^2-y^2}}^{y+a} f(x, y) dx.$$

8. The density of a square lamina is proportional to the distance from one corner. Determine the mass of the lamina.

Ans. $.765 \lambda a^3$.

9. Find the centre of gravity of the lamina in the preceding question.

$$*Ans.* \bar{x} = \bar{y} = \frac{a[7\sqrt{2} - 2 + 3\log(1 + \sqrt{2})]}{8[\sqrt{2} + \log(1 + \sqrt{2})]}.$$

10. Two circles are tangent to each other internally. Determine the moment of inertia of the region between them about the point of tangency.

11. Find the attraction of a uniform circular disc on a particle situated in a line perpendicular to the plane of the disc at its centre.

12. Solve the same problem for a rectangular disc.

$$\text{Ans. } \kappa \frac{mM}{ab} \tan^{-1} \frac{ab}{h \sqrt{h^2 + a^2 + b^2}}.$$

13. Determine the attraction of a uniform rectangle on an exterior particle situated in a parallel to two of its sides, passing through its centre.

$$\text{Ans. } \kappa \frac{mM}{2ab} \log \left[\frac{h+a}{h-a} \cdot \frac{b + \sqrt{(h-a)^2 + b^2}}{b + \sqrt{(h+a)^2 + b^2}} \right].$$

14. The intensity of light issuing from a point source is inversely proportional to the square of the distance from the source. Formulate as an integral the total illumination of a plane region by an arc light exterior to the plane.

15. Compute the illumination in the foregoing question on the interior of the curve

$$r^2 = 1 - \theta^2,$$

the light being situated in the perpendicular to the plane of the curve at $r = 0$.

$$\text{Ans. } 2\lambda(1 - h \cot^{-1} h).$$

16. One loop of the curve

$$r^3 = a^3 \cos 3\theta$$

is immersed in a liquid, the pole being at the surface and the initial line vertical and directed downward. Find the pressure on the surface.

$$\text{Ans. } \frac{wa^3 \sqrt{3}}{8}.$$

17. One loop of the lemniscate

$$r^2 = a^2 \cos 2\theta$$

is immersed as the loop of the curve in the preceding question. Find the centre of pressure.

$$\text{Ans. Distance below the surface} = a \sqrt{2} \left(\frac{2}{3\pi} + \frac{1}{4} \right).$$

18. Formulate the volume of a solid of revolution as a double integral.

19. The curve

$$\cos \theta = 3 - 3r + r^2$$

rotates about the initial line. Find the volume of the solid generated.

$$\text{Ans. } \frac{23\pi}{30}.$$

20. Find the volume cut from a circular cylinder whose axis is parallel to the axis of z , by the x, y plane and the surface

$$xy = az.$$

Assume that the cylinder does not cut the coordinate axes.

$$\text{Ans. } \frac{\pi h k r^2}{a}.$$

21. A cone of revolution has its vertex in the surface of a sphere, its axis coinciding with a diameter. Find the volume common to the two surfaces.

$$\text{Ans. } \frac{4}{3}\pi a^3(1 - \cos^4 \alpha).$$

22. Determine the volume of an anchor ring.

23. Determine the area of the surface of an anchor ring.

24. Find the moment of inertia of an anchor ring about its axis.

$$\text{Ans. } M \left(\frac{3a^2}{4} + b^2 \right).$$

25. Find the area of that part of the surface

$$z = \tan^{-1} \frac{y}{x}$$

which lies in the first octant below the plane $z = \pi/2$ and within the cylinder $x^2 + y^2 = 1$.

26. Obtain a formula for the centre of gravity of a curved surface of variable density.

27. Obtain a formula for the components of the attraction which a surface of constant or of variable density exerts on a particle of matter not lying in the surface.

Hence show that the force with which a homogeneous piece of the surface of a sphere lying wholly in one hemisphere and symmetrical with reference to the diameter perpendicular to the base of the hemisphere attracts a particle situated at the centre of the sphere is proportional to the projection of the piece on the base.

28. Find the moment of inertia about the origin of the portion of the first quadrant bounded by the curve

$$(x + 1)(y + 1) = 4,$$

correct to three significant figures.

29. Find the volume of a column capped by the surface

$$z = xy,$$

the base of the column being the portion of the first quadrant in the x, y plane which lies between two successive coils of the logarithmic spiral:

$$r = ae^{\theta}.$$

$$\text{Ans. } \frac{a^4}{80}(e^{8\pi} - 1)(e^{2\pi} + 1).$$

30. Find the abscissa of the centre of gravity of the above column.

31. A square hole $2b$ on a side is bored through a cylinder of radius a , the axis of the hole intersecting the axis of the cylinder at right angles. Find the volume of the chips cut out.

$$\text{Ans. } 4b^2\sqrt{a^2 - b^2} + 4a^2b \sin^{-1}\frac{b}{a}.$$

32. A square hole $2b$ on a side is bored through a sphere of radius a , the axis of the hole going through the centre of the sphere. Find the volume of the chips cut out.

$$\text{Ans. } 2\pi a^2 - 8a^2 \left[\sin^{-1} \frac{a}{\sqrt{2(a^2 - b^2)}} - \frac{b}{a} \tan^{-1} \frac{b}{\sqrt{a^2 - 2b^2}} \right].$$

CHAPTER XIX

TRIPLE INTEGRALS

1. Definition of the Triple Integral. Let a function of three independent variables, $f(x, y, z)$, be given, continuous throughout a region V of three dimensional space. Let this region be divided in any manner into small pieces, of volume ΔV_k , and let (x_k, y_k, z_k) be an arbitrary point of the k -th piece. Form the product $f(x_k, y_k, z_k) \Delta V_k$ and add all these products together:

$$(1) \quad \sum_{k=0}^{n-1} f(x_k, y_k, z_k) \Delta V_k.$$

When n is made to grow larger and larger without limit, the greatest diameter of each of the elementary volumes approaching 0 as its limit, the sum (1) approaches a limit, and this limit is defined as the *triple* or *volume integral* of the function f throughout the region V :

$$(2) \quad \lim_{n \rightarrow \infty} \sum_{k=0}^{n-1} f(x_k, y_k, z_k) \Delta V_k = \iiint_V f dV.$$

It is not essential that the totality of the elementary volumes should just fill out the region V . We might, for example, divide space up into small rectangular parallelepipeds, the lengths of whose edges are $\Delta x, \Delta y, \Delta z$, and consider such as are interior to V , or such as have at least one point of V in their interior or on their boundary.

The integral is also written as follows:

$$\iiint_V f(x, y, z) dx dy dz.$$

The proof involved in the above definition, that the sum (1) actually approaches a limit, has to be given along different lines for triple integrals, from what was possible in the case of double integrals. There, we were able to represent the sum

$$\sum_{k=0}^{n-1} f(x_k, y_k) \Delta S_k$$

by a variable volume which obviously approached a fixed volume as its limit. Here, we should need a four dimensional space in which to represent geometrically the sum (1). It is necessary, therefore, to fall back on an analytical proof. Such a proof will be found in Goursat-Hedrick, *Mathematical Analysis*, Vol. 1, Chap. VII. The proofs of this and the later theorems of this chapter belong properly to a later stage of analysis. The theorems themselves, however, are easily intelligible from their analogy with the corresponding theorems for double integrals, and it is our purpose here to state them and to explain their uses.

EXERCISES

1. Show that the mass of a body, of variable density ρ , is

$$M = \iiint_V \rho dV,$$

and that

$$\bar{x} = \frac{\iiint_V \rho x dV}{\iiint_V \rho dV} = \frac{\iiint_V \rho x dV}{M},$$

$$I = \iiint_V \rho r^2 dV,$$

where r denotes the distance of a variable point from the axis.

2. Formulate as a triple integral the attraction of a body on a particle exterior to it.

2. The Iterated Integral. In order to compute the value of the volume integral defined in § 1 we introduce an iterated integral. The method is that of Chap. XVIII, §§ 10, 11. Let the region V be divided up by planes parallel to the coordinate planes into rectangular parallelepipeds whose edges are of lengths Δx , Δy , Δz , and let us take as our elements of volume these little solids. Then $\Delta V_k = \Delta x \Delta y \Delta z$, and the sum (1) becomes

$$(3) \quad \sum_{k=0}^{n-1} f(x_k, y_k, z_k) \Delta x \Delta y \Delta z.$$

We will select from this sum the terms that correspond to elements situated in a column parallel to the axis of z and add them together, see Fig. 108:

$$\Delta x \Delta y \sum_{l=0}^{s-1} f(x_i, y_j, z_l) \Delta z,$$

where we have assigned new indices, i , j , and l , to the coordinates of the point (x_k, y_k, z_k) and where furthermore we have chosen the points (x_k, y_k, z_k) of this column so that they all lie in the line $x = x_i$, $y = y_j$. If, now, still holding x_i , y_j , Δx , and Δy fast, we allow s to increase without limit, Δz approaching 0, we have

$$\Delta x \Delta y \lim_{s \rightarrow \infty} \sum_{l=0}^{s-1} f(x_i, y_j, z_l) \Delta z = \Delta x \Delta y \int_{z'}^{z''} f(x_i, y_j, z) dz,$$

where z' is the smallest ordinate of the points of V on the line $x = x_i$, $y = y_j$, and z'' is the largest, — we assume for simplicity that the surface of V is met by a parallel to any one of the coordinate axes which traverses the interior of V in two points.

Next, we add all the limits of these columns together:

$$\sum \Phi(x_i, y_j) \Delta x \Delta y,$$

where we have set

$$\int_{z'}^{z''} f(x, y, z) dz = \Phi(x, y),$$

and take the limit of this sum. The region S of the x, y plane over which this summation is extended consists of the projections of the points of V on that plane, and hence the limit of this sum is the double integral of $\Phi(x, y)$, extended over S :

$$\lim \sum \Phi(x_i, y_j) \Delta x \Delta y = \iint_S \Phi dS = \int_a^b dx \int_{y'}^{y''} \Phi(x, y) dy.$$

We are thus led to the final result:

FUNDAMENTAL THEOREM OF THE INTEGRAL CALCULUS:

$$\begin{aligned} (4) \quad \iiint_V f dV &= \iint_S dS \int_{z'}^{z''} f(x, y, z) dz \\ &= \int_a^b dx \int_{y'}^{y''} dy \int_{z'}^{z''} f(x, y, z) dz. \end{aligned}$$

Another notation for the iterated integral is as follows:

$$\int_a^b \int_{y'}^{y''} \int_{z'}^{z''} f(x, y, z) dz dy dx.$$

Any other choice of the orders of integration is equally allowable.

An example or two will serve to illustrate the process.

Example. Find the moment of inertia of a tetrahedron whose face angles at a vertex O are all right angles, about an edge adjacent to O .

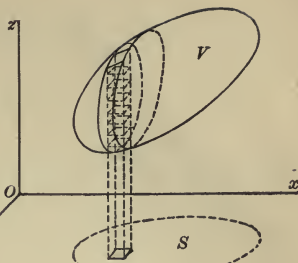

FIG. 108

Take O as the origin of coordinates and the three adjacent edges as the axes. Then

$$I = \rho \int_V \int \int (x^2 + y^2) dV = \rho \int_0^a dx \int_0^y dy \int_0^z (x^2 + y^2) dz,$$

where the limits of integration are as follows. First, the limit $z' = 0$ and the limit $z'' = Z$ is the maximum ordinate in V corresponding to an arbitrary pair of values x, y ; *i.e.* the ordinate of a point in the oblique face of the tetrahedron:

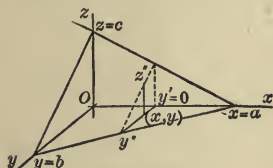

FIG. 109

$$\frac{x}{a} + \frac{y}{b} + \frac{z}{c} = 1.$$

$$\text{Hence } Z = c \left(1 - \frac{x}{a} - \frac{y}{b} \right),$$

and the result of the first integration is:

$$\begin{aligned} \Phi(x, y) &= \int_0^z (x^2 + y^2) dz = (x^2 + y^2) z \Big|_0^z = c(x^2 + y^2) \left(1 - \frac{x}{a} - \frac{y}{b} \right) \\ &= c \left[x^2 \left(1 - \frac{x}{a} \right) - \frac{x^2}{b} y + \left(1 - \frac{x}{a} \right) y^2 - \frac{y^3}{b} \right]. \end{aligned}$$

Next, this latter function must be integrated over the surface S consisting of a triangle bounded by the positive axes of x and y , and the line

$$\frac{x}{a} + \frac{y}{b} = 1.$$

This double integral may be computed by iterated integration, the limits of integration for y being $y' = 0$ and

$$y'' = Y = b \left(1 - \frac{x}{a} \right),$$

and those for x , 0 and a . The remainder of the computation is, therefore, as follows:

$$\int_0^x dy \int_0^z (x^2 + y^2) dz = \frac{bc}{12} \left[6x^2 \left(1 - \frac{x}{a} \right)^2 + b^2 \left(1 - \frac{x}{a} \right)^4 \right],$$

$$\int_0^a dx \int_0^x dy \int_0^z (x^2 + y^2) dz = \frac{abc}{60} (a^2 + b^2);$$

$$\therefore I = \frac{M(a^2 + b^2)}{10}.$$

The student can verify the answer by slicing the tetrahedron up by planes parallel to the x, y plane and employing the result of Ex. 1 at the end of § 5 in Chap. XVIII.

EXERCISES

1. Find the centre of gravity of the above tetrahedron.
2. Determine the moment of inertia of a rectangular parallelepiped about an axis passing through its centre and parallel to four of its edges.
3. A square column has for its upper base a plane inclined to the horizon at an angle of 45° and cutting off equal intercepts on two opposite edges. How far is the centre of gravity of the column from the axis?

$$\text{Ans. } \frac{a^2}{3h}.$$

3. Continuation; Polar Coordinates. In space there are two systems of polar coordinates in common use, namely, spherical coordinates and cylindrical coordinates.

Spherical Coordinates. Let P , with the cartesian coordinates x, y, z , be any point of space. Its spherical coordinates are defined as indicated in the figure. If we think of P as a point of a sphere with its centre at O and of radius r , then θ is the longitude and ϕ is the colatitude of P .

We have

$$x = r \sin \phi \cos \theta,$$

$$y = r \sin \phi \sin \theta,$$

$$z = r \cos \phi.$$

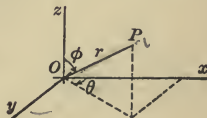

FIG. 110

We propose the problem of computing the volume integral

$$(5) \quad \lim_{n \rightarrow \infty} \sum_{k=0}^{n-1} f(x_k, y_k, z_k) \Delta V_k = \iiint_V f dV$$

by means of iterated integration in spherical coordinates. For this purpose we will divide the region V up into elementary volumes as follows. Construct (a) a set of spheres with O as their common centre, $r=r_i$, their radii increasing by Δr ; (b) a set of half-planes $\theta=\theta_j$, the angle between two successive planes being $\Delta\theta$; and lastly (c) a set of cones $\phi=\phi_i$, their semi-vertical angle increasing by $\Delta\phi$: $\phi_{i+1}-\phi_i=\Delta\phi$. The element of volume thus obtained is indicated in Fig. 111. The lengths of the three edges that meet at right angles at P are Δr , $r\Delta\phi$, $r\sin\phi\Delta\theta$, and hence this volume ΔV differs from

the volume of a rectangular parallelepiped with the edges just named:

$$(6) \quad r^2 \sin \phi \Delta r \Delta \theta \Delta \phi$$

by an infinitesimal of higher order:

$$\lim \frac{\Delta V}{r^2 \sin \phi \Delta r \Delta \theta \Delta \phi} = 1.$$

It follows, then, from Duhamel's Theorem that in the limit of the

sum (5) we may replace ΔV_k by the infinitesimal (6). If we set

$$f(x, y, z) = F(r, \theta, \phi),$$

we have
$$\iiint_V f dV = \lim_{n \rightarrow \infty} \sum_{k=0}^{n-1} F(r_k, \theta_k, \phi_k) r_k^2 \sin \phi_k \Delta r \Delta \theta \Delta \phi.$$

Can we evaluate this last limit by iterated integration? It is easy to see that we can. For the sum is of the type of the sum (3), and hence the method of § 2 is applicable. Following that method, let us select, for example, those terms for which θ and ϕ have a constant value, and add them together:

$$\Delta\theta\Delta\phi \sum_{i=0}^{p-1} F(r_i, \theta_j, \phi_i) r_i^2 \sin \phi_i \Delta r,$$

where θ_j and ϕ_i are constant. They correspond to elementary volumes lying in a row bounded by the planes $\theta=\theta_j$ and

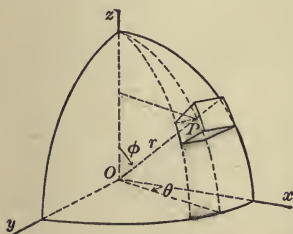

FIG. 111

$\theta = \theta_{j+1}$, and by the cones $\phi = \phi_l$ and $\phi = \phi_{l+1}$. Now allow p to increase without limit, Δr approaching 0. This gives, as the limit of the above sum,

$$\Delta\theta\Delta\phi \sin \phi_l \int_{r'}^{r''} r^2 F(r, \theta_j, \phi_l) dr,$$

where r' is the distance of the nearest point of V to O on the line $\theta = \theta_j$, $\phi = \phi_l$, and r'' , that of the farthest. We assume for simplicity that the surface of V is met by any one of the lines:

$$\left\{ \begin{array}{l} \theta = \text{const.}, \\ \phi = \text{const.}, \end{array} \right. \quad \left\{ \begin{array}{l} \phi = \text{const.}, \\ r = \text{const.}, \end{array} \right. \quad \left\{ \begin{array}{l} r = \text{const.}, \\ \theta = \text{const.}, \end{array} \right.$$

which traverses the interior of V , in two points.

Next, we add all the limits thus obtained together:

$$\sum \Phi(\theta_j, \phi_l) \Delta\theta\Delta\phi,$$

where we have set

$$\sin \phi \int_{r'}^{r''} F(r, \theta, \phi) r^2 dr = \Phi(\theta, \phi),$$

and take the limit of this sum. If we interpret θ and ϕ as the coordinates of a point on the surface of a sphere $r = \text{const.}$ (say, $r = 1$), then the region S over which the above sum is to be extended consists of those points in which radii vectors drawn to points of V pierce the surface of this sphere. Hence the limit of this sum is the double integral of $\Phi(\theta, \phi)$, extended over S :

$$\begin{aligned} \lim \sum \Phi(\theta_j, \phi_l) \Delta\theta\Delta\phi &= \int_S \int \Phi(\theta, \phi) dS \\ &= \int_{\alpha}^{\beta} d\theta \int_{\phi'}^{\phi''} \sin \phi d\phi \int_{r'}^{r''} F(r, \theta, \phi) r^2 dr. \end{aligned}$$

We are thus led to the following result:

$$(c) \quad \iiint_V f dV = \int_a^{\beta} d\theta \int_{\phi'}^{\phi''} \sin \phi d\phi \int_r^r f r^2 dr$$

The student is requested after a careful study of the foregoing, to think through for himself the cases in which the first integration is performed (a) with respect to θ ; (b) with respect to ϕ .

The above volume integral and the iterated integral are also written in the forms:

$$\iiint_V f r^2 \sin \phi dr d\theta d\phi \quad \text{and} \quad \int_a^{\beta} \int_{\phi'}^{\phi''} \int_r^r f r^2 \sin \phi dr d\phi d\theta.$$

Example. To find the centre of gravity of a homogeneous hemispherical shell whose radii are a and A .

$$\text{Here } \bar{x} = \frac{\rho \iiint_V x dV}{M}, \quad M = \frac{2\pi}{3} \rho (A^3 - a^3);$$

$$\begin{aligned} \iiint_V x dV &= \iiint_V r \sin \phi \cos \theta dV \\ &= \int_{-\frac{\pi}{2}}^{\frac{\pi}{2}} d\theta \int_0^{\pi} d\phi \int_a^A r^2 \sin^2 \phi \cos \theta dr = \frac{\pi (A^4 - a^4)}{4}. \end{aligned}$$

$$\bar{x} = \frac{3(a^3 + a^2A + aA^2 + A^3)}{8(a^2 + aA + A^2)}.$$

Check. When $a = A$, $\bar{x} = \frac{1}{2}A$; when $a = 0$, $\bar{x} = \frac{3}{8}a$.

The student may solve the same problem, taking the axis of symmetry as the axis of z and computing \bar{z} .

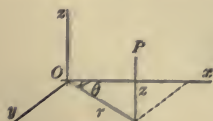

FIG. 112

Cylindrical Coordinates. The cylindrical coordinates of a point are defined as in the accompanying figure. They are a combination of polar coordinates in the x, y plane and the cartesian z .

$$x = r \cos \theta, \quad y = r \sin \theta, \quad z = z.$$

The element of volume is shown in Fig. 113. The lengths of the edges adjacent to P , — they meet at right angles there, — are: Δr , $r\Delta\theta$, Δz . Hence the volume ΔV of the element differs from $r\Delta r\Delta\theta\Delta z$ by an infinitesimal of higher order, and we have:

$$\lim \frac{\Delta V}{r\Delta r\Delta\theta\Delta z} = 1.$$

From Duhamel's Theorem it follows, then, that in taking the limit of the sum (1), ΔV_k may be replaced by $r_k \Delta r \Delta \theta \Delta z$, and so, setting

$$f(x, y, z) = F(r, \theta, z),$$

we obtain:
$$\iiint_V f dV = \lim_{n \rightarrow \infty} \sum_{k=0}^{n-1} F(r_k, \theta_k, z_k) r_k \Delta r \Delta \theta \Delta z.$$

This last limit can be computed by iterated integration in a manner precisely similar to that set forth in the case of spherical coordinates. We thus obtain:

$$(8) \quad \iiint_V f dV = \int_a^b dz \int_{\psi'}^{\psi''} d\theta \int_{r'}^{r''} f r dr,$$

together with similar formulas yielded by adopting a different order of integration.

The above volume integral and the iterated integral are also written in the forms:

$$\iiint_V f r dr d\theta dz \quad \text{and} \quad \int_a^b \int_{\psi'}^{\psi''} \int_{r'}^{r''} f r dr d\theta dz.$$

Example. To find the attraction of a cylindrical bar on a particle of unit mass situated in its axis.

The magnitude of the attraction is evidently*

* The unit of force is here taken as the gravitational unit.

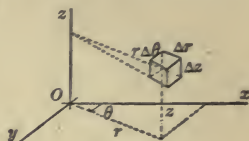

FIG. 113

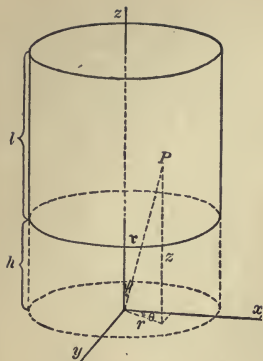

FIG. 114

$$A = \iiint_V \frac{\rho \cos \psi}{r^2} dV.$$

Here

$$r^2 = r^2 + z^2, \quad \cos \psi = \frac{z}{r} = \frac{z}{\sqrt{r^2 + z^2}}.$$

Hence

$$A = \rho \int_0^{2\pi} d\theta \int_h^{h+l} dz \int_0^a \frac{zr dr}{(r^2 + z^2)^{3/2}}.$$

$$\int_0^a \frac{zr dr}{(r^2 + z^2)^{3/2}} = -\frac{z}{\sqrt{r^2 + z^2}} \Big|_0^a$$

$$= 1 - \frac{z}{\sqrt{a^2 + z^2}};$$

$$\int_h^{h+l} dz \int_0^a \frac{zr dr}{(r^2 + z^2)^{3/2}} = l - \int_h^{h+l} \frac{z dz}{\sqrt{a^2 + z^2}}$$

$$= l - \sqrt{a^2 + (h+l)^2} + \sqrt{a^2 + h^2};$$

$$\therefore A = 2\pi\rho [l + \sqrt{a^2 + h^2} - \sqrt{a^2 + (h+l)^2}].$$

EXERCISES

1. Determine the attraction of a straight pipe on a particle situated in its axis.

2. Find the force with which a cone of revolution attracts a particle at its vertex. *Ans.* $2\pi\rho h(1 - \cos \alpha)$.

3. Show that the force with which a piece of a spherical shell cut out by a cone of revolution with its vertex at the centre O attracts a particle at O depends, for a given cone, only on the thickness of the shell.

4. Prove the preceding theorem for any cone.

4. Line Integrals. Line integrals present themselves in such physical problems as that of finding the work done by a variable force when the point of application describes a curve.

Let a plane curve C :

$$y = f(x) \quad \text{or} \quad F(x, y) = 0,$$

be given. Its coordinates can always be expressed as functions of the arc s , measured from an arbitrary point. Thus in the case of the circle

$$x^2 + y^2 = a^2$$

we can write

$$x = a \cos \frac{s}{a}, \quad y = a \sin \frac{s}{a},$$

where s is measured from the point $(a, 0)$. We will think of the equation of the curve C , therefore, as expressed in the form:

$$(1) \quad x = \phi(s), \quad y = \psi(s).$$

Consider next a function $F(s)$ defined at each point of the curve. It may be given as a function both of the coordinates x, y of a variable point P of the plane and of the arc s ; $f(x, y, s)$. But in the latter case P is to lie on C , and so x and y have the values given by (1), $f(x, y, s)$ thus becoming a function of s alone:

$$f(x, y, s) = f[\phi(s), \psi(s), s] = F(s).$$

We will now divide the arc up into n equal parts by the points $s_0 = 0, s_1, \dots, s_{n-1}, s_n = l$ and form the sum:

$$\sum_{k=0}^{n-1} F(s_k) \Delta s.$$

The limit of this sum as n becomes infinite is

$$\int_0^l F(s) ds,$$

and is called the *line integral* of the function $F(s)$ or $f(x, y, s)$ taken along C . Other notations for this integral are

$$\int_C f(x, y, s) ds \quad \text{and} \quad \int_{(x_0, y_0)}^{(x_1, y_1)} f(x, y, s) ds,$$

where (x_0, y_0) and (x_1, y_1) are the coordinates of the extremities of the arc C .

Geometrically the line integral admits of a simple interpretation. Let a cylinder be constructed on C as generatrix, its elements being perpendicular to the x, y plane, and let the values of the function $F(s)$ be laid off along the elements of this cylinder. Then the area of the cylinder bounded by this curve and the generatrix represents the line integral in question.

As an example of a line integral, suppose a point moves in a field of force. Let the magnitude of the force be \mathfrak{F} and let the force make an angle θ with the tangent to C drawn in the direction of the motion. Then the component

of the force along the curve is $\mathfrak{F} \cos \theta$, and the work done by the force is

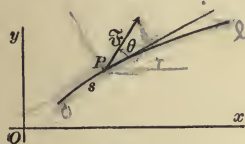

FIG. 115

(2)

$$W = \int_0^l \mathfrak{F} \cos \theta ds.$$

A Second Form of the Line Integral. A second form in which line integrals appear is the following:

$$\int_{(x_0, y_0)}^{(x', y')} P dx + Q dy,$$

the meaning of the integral being this. Two functions $P(x, y)$, $Q(x, y)$ of the independent variables x, y are given, the curve is divided as before, and the sum

$$(3) \quad \sum_{k=0}^{n-1} [P(x_k, y_k) \Delta x_k + Q(x_k, y_k) \Delta y_k]$$

is formed, Δx_k denoting the difference $x_{k+1} - x_k$, and similarly for Δy_k . The limit of this sum is the limit in question.

To evaluate the limit, we may write the summand in the form:

$$\left(P(x_k, y_k) \frac{\Delta x_k}{\Delta s} + Q(x_k, y_k) \frac{\Delta y_k}{\Delta s} \right) \Delta s.$$

Now $\lim_{\Delta s \rightarrow 0} \frac{\Delta x}{\Delta s} = \cos \tau, \quad \lim_{\Delta s \rightarrow 0} \frac{\Delta y}{\Delta s} = \sin \tau,$

and hence by Duhamel's Theorem the limit of (3) and the limit of the sum

$$\sum_{k=0}^{n-1} [P(x_k, y_k) \cos \tau_k + Q(x_k, y_k) \sin \tau_k] \Delta s$$

are the same. But the limit of the latter sum is

$$\int_0^l [P(x, y) \cos \tau + Q(x, y) \sin \tau] ds = \int_0^l \left(P \frac{dx}{ds} + Q \frac{dy}{ds} \right) ds,$$

where the x and y in the integrands are given by (1).

As an example of the second form of line integral consider again a field of force, the components of the force along the axes being denoted at each point by X, Y . Then the work done by the force when the point of application describes the curve C is

$$(4) \quad W = \int_{(x_0, y_0)}^{(x_1, y_1)} X dx + Y dy.$$

The relation between formulas (2) and (4) for the work becomes clear when we consider the special case that the point of application P moves in a right line, the force not changing in magnitude or direction. One expression for the work, — that corresponding to (2), — is

$$W = (\mathfrak{F} \cos \theta) l.$$

On the other hand, the work done by the component X is

$$(X \cos \tau) l = X(x_1 - x_0),$$

and that done by Y ,

$$(Y \sin \tau) l = Y(y_1 - y_0).$$

Hence we ought to have:

$$\mathfrak{F} l \cos \theta = X(x_1 - x_0) + Y(y_1 - y_0).$$

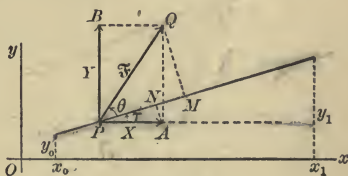

FIG. 116

That this is in fact a true relation is readily seen. For the component of \mathfrak{F} along the line P describes, namely

$$PM = \mathfrak{F} \cos \theta,$$

is equal to the sum of the components of X and Y , namely,

$$PN = X \cos \tau \quad \text{and} \quad NM = Y \sin \tau.$$

But
$$\cos \tau = \frac{x_1 - x_0}{l}, \quad \sin \tau = \frac{y_1 - y_0}{l}.$$

Hence
$$\mathfrak{F} \cos \theta = X \frac{x_1 - x_0}{l} + Y \frac{y_1 - y_0}{l},$$

and thus the above relation is seen to be true.

When the force changes and the path is a curve, we still have

$$\mathfrak{F} \cos \theta = X \cos \tau + Y \sin \tau = X \frac{dx}{ds} + Y \frac{dy}{ds},$$

and hence
$$\mathfrak{F} \cos \theta ds = X dx + Y dy.$$

Space Curves. Both line integrals admit of immediate extension to space curves C :

$$x = \phi(s), \quad y = \psi(s), \quad z = \omega(s),$$

the first integral giving

$$\int_0^l f(x, y, z, s) ds = \int_0^l f[\phi(s), \psi(s), \omega(s), s] ds = \int_0^l F(s) ds,$$

and the second,

$$\int_{(x_0, y_0, z_0)}^{(x_1, y_1, z_1)} P dx + Q dy + R dz.$$

Thus in the case of a field of force we should have for the work:

$$W = \int_{(x_0, y_0, z_0)}^{(x_1, y_1, z_1)} X dx + Y dy + Z dz.$$

Example. Let a particle move along a given path in interplanetary space. To find the work done on it by the earth, supposed stationary.

Assume a system of cartesian axes with the origin at the centre of the earth. Then the magnitude of the attraction will be

$$\mathfrak{F} = \frac{\lambda}{r^2}$$

and we shall have

$$X = \mathfrak{F} \cos \alpha = \frac{\lambda}{r^2} \cdot \frac{x}{r},$$

$$Y = \mathfrak{F} \cos \beta = \frac{\lambda}{r^2} \cdot \frac{y}{r},$$

$$Z = \mathfrak{F} \cos \gamma = \frac{\lambda}{r^2} \cdot \frac{z}{r};$$

$$W = \lambda \int_{(x_0, y_0, z_0)}^{(x_1, y_1, z_1)} \frac{x dx + y dy + z dz}{r^3} = \lambda \int_{r_0}^{r_1} \frac{dr}{r^2} = \lambda \left(\frac{1}{r_0} - \frac{1}{r_1} \right).$$

Thus we see that the work done depends only on the positions of the extremities of C , not on the particular path joining the points, *i.e.* we have a *conservative field of force*.

In connection with this subject we will mention the following definition. Hitherto we have defined the definite integral:

$$\int_a^b f(x) dx$$

only for the case that $a < b$. If $a > b$, the definition is, however, still valid, $\Delta x = (b - a) / n$ now being negative. Hence in all cases

$$\int_a^b f(x) dx = - \int_b^a f(x) dx.$$

Furthermore we agree that

$$\int_a^a f(x) dx = 0.$$

From these relations we infer that

$$\int_a^b f(x) dx = \int_a^c f(x) dx + \int_c^b f(x) dx,$$

no matter how a , b , and c are related to each other. We can also write:

$$\int_a^b f(x) dx + \int_b^c f(x) dx + \int_c^a f(x) dx = 0.$$

EXERCISES

1. The density of a rectangular parallelopiped is proportional to the square of the distance from one vertex. Find its mass.

$$\text{Ans. } \frac{\lambda abc}{3} (a^2 + b^2 + c^2).$$

2. Determine accurately the volume of the element in spherical polar coordinates, Fig. 111.

3. Find the centre of gravity of the volume in the preceding question.

4. Express the iterated integral

$$\int_0^a dx \int_0^{\frac{b}{a}\sqrt{a^2-x^2}} dy \int_{x+y}^{2+4x+5y} f dz$$

as a volume integral, and state throughout what region of space the latter is to be extended.

5. The same for

$$\int_{-\frac{\pi}{2}}^{\frac{\pi}{2}} \cos \theta d\theta \int_0^{\frac{\pi}{4}} \sin \phi d\phi \int_{2b \cos \phi}^{2a \cos \phi} dr.$$

6. Write down the five equivalent forms of the integral

$$\int_0^a dy \int_0^y dx \int_0^x f(x, y, z) dz,$$

obtained by changing the order of the integrations.

7. Two spheres are tangent to each other internally, and also to the x, y plane at the origin. Denoting the space included between the spheres by V , express the volume integral

$$\iiint_V f dV$$

by means of iterated integrals in cartesian coordinates.

8. The temperature within a spherical shell is inversely proportional to the distance from the centre, and has the value T_0 on the inner surface. Given that the quantity of heat required to raise any piece of the shell from one uniform temperature to another is proportional jointly to the volume of the piece and the rise in temperature, and that C units of heat are required to raise the temperature of a cubic unit of the shell by one degree, find how much heat the shell will give out in cooling to the temperature 0° . *Ans.* $2\pi C T_0 a(b^2 - a^2)$.

9. The interior of an iron pipe is kept at 100°C . and the exterior at 15° . The length of the inner radius of the pipe is 2 cm., that of the outer radius, 3 cm. The temperature at any interior point is given by the formula:

$$T = \alpha \log r + \beta,$$

where r is the distance from the axis and the constants α, β are to be determined from the above data. Taking the specific heat of iron as .11, and its specific gravity as 7.8, how much heat will a segment of the pipe 30 cm. long give out in cooling to 0° ? *Ans.* 21,000 calories.

10. Determine the attraction of a bar, of rectangular cross-section, on an exterior particle situated in its axis.

CHAPTER XX

APPROXIMATE COMPUTATIONS. HYPERBOLIC FUNCTIONS

1. The Problem of Numerical Computation. It frequently happens in practice that we wish to know the value of a function for a special value of the independent variable or that we wish to compute a definite integral. In all such cases only a limited number of decimal places or of significant figures, as the case may be, are of interest in the result, for the data of the problem are accompanied by errors of observation or are otherwise inexact, and as soon as these errors begin to make themselves felt, we have obviously reached the limit of accuracy for the result in hand. Hence any method that will enable us to obtain the result with the degree of accuracy above indicated yields a solution of our problem.

On the other hand, rough approximate solutions of the kind we are about to take up serve as useful checks for solutions obtained by other methods.

2. Solution of Equations. Known Graphs.

*Example.** Let it be required to solve the equation

$$(1) \quad \cos x + \frac{1}{4}x = 0, \quad 0 < x < \pi.$$

The student has constructed the graph of the curve

$$(2) \quad y = \cos x$$

* This example and the exercise present themselves in the following problem of Mechanics. A heavy uniform circular disc can turn freely

accurately to scale. Since equation (1) is equivalent to the equation

$$(3) \quad -\frac{1}{4}x = \cos x,$$

we can obviously formulate our problem as follows. To find the intersection of the curves :

$$y = -\frac{1}{4}x, \quad y = \cos x.$$

Graphically, then, it will be sufficient to draw a straight line through the origin and the point $x = 4, y = -1$, and observe the abscissa of the point of intersection with the cosine curve.

EXERCISE

Find the largest value of P for which the equation :

$$\cos x + Px = 0$$

admits a solution in the interval $0 < x < \pi$.

3. Newton's Method. Let it be required to solve the equation

$$(4) \quad f(x) = 0.$$

In practice we usually know that the equation has a solution within a restricted interval. Moreover, $f(x)$ will be a continuous function in this interval, and its derivative will not vanish there. We can frequently make a good guess at the solution to begin with. Take this value, $x = a_1$, as a first approximation. Then we shall get a second approximation if we draw the tangent at the point $x = a_1, y = f(a_1)$ and take the point $x = a_2$ in which the tangent cuts the axis of $x, y = 0$, Fig. 117.

The equation of the tangent in question is

about a horizontal axis through its centre, perpendicular to its plane. There is a weight W fastened to the rim of the disc and a fine thread is wound round the rim and hangs down, carrying a weight Q at its end. W being at the lowest point of the disc and the free end of the string being vertical, the system is released. Find how high W will rise and determine the least value of W for which W will not be pulled over.

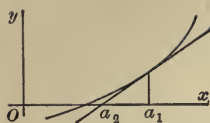

FIG. 117

$$y - f(a_1) = f'(a_1)(x - a_1).$$

For its point of intersection with the axis of x :

$$0 - f(a_1) = f'(a_1)(x - a_1).$$

Hence
$$a_2 = a_1 - \frac{f(a_1)}{f'(a_1)}.$$

To get a third approximation, proceed with a_2 as above with a_1 , and so on.

If $f(x)$ is a polynomial with numerical coefficients, the actual computation of $f(a_1)$ and $f'(a_1)$ would be laborious. To meet this difficulty *Horner's Method* has been devised, cf. any of the standard text-books on Higher Algebra.

Example. It is shown that the equation of the curve in which a chain hangs, — the *Catenary*, — is

$$(5) \quad y = \frac{a}{2} \left(e^{\frac{x}{a}} + e^{-\frac{x}{a}} \right),$$

where a is a constant. The length of the arc, measured from the vertex, is

$$(6) \quad s = \frac{a}{2} \left(e^{\frac{x}{a}} - e^{-\frac{x}{a}} \right).$$

Let it be required to compute the dip in a chain 32 feet long, its ends being supported at the same level, 30 feet apart.

We can determine the dip from (5) if we know a , and we can get the value of a from (6) by setting $s = 16$, $x = 15$:

$$16 = \frac{a}{2} \left(e^{\frac{15}{a}} - e^{-\frac{15}{a}} \right).$$

Let $x = \frac{15}{a}$. Then

$$f(x) = e^x - e^{-x} - \frac{32}{15}x = 0,$$

and we wish to know where the curve

$$(7) \quad y = f(x) = e^x - e^{-x} - \frac{3}{15}x$$

crosses the axis of x .

This curve starts from the origin and, since

$$\frac{dy}{dx} = f'(x) = e^x + e^{-x} - \frac{3}{15}$$

is negative for small values of x , the curve enters the fourth quadrant. Moreover,

$$\frac{d^2y}{dx^2} = e^x - e^{-x} > 0, \quad x > 0,$$

and hence the graph is always concave upward. Finally,

$$f(1) = e - e^{-1} - 2\frac{2}{15} = .217 > 0,$$

and so the equation has one and only one positive root and this root lies between 0 and 1.

It will probably be better to locate the root with somewhat greater accuracy before beginning to apply the above method. Let us compute, therefore, $f(\frac{1}{2})$. By the aid of the *Tables*, p. 121, we find:

$$f(.5) = 1.6487 - .6065 - 1.0667 = -.0245 < 0.$$

Comparing these two values of the function:

$$f(.5) = -.02, \quad f(1) = .22,$$

and remembering that the curve is concave upward, so that the root is somewhat larger than the value obtained by direct interpolation (this value corresponding to the intersection of the chord with the axis of x) we are led to choose as our first approximation $a_1 = .6$:

$$f(.6) = 1.8221 - .5488 - 1.2800 = -.0067,$$

$$f'(.6) = 1.8221 + .5488 - 2.1333 = .2376,$$

$$a_2 = .6 - \frac{-.0067}{.2376} = .6 + .0282 = .628.$$

To get the next approximation, a_3 , we compute

$$f(.628) = 1.8739 - .5337 - 1.3397 = .0005.$$

Hence the value of the root to three significant figures is .628 with a possible error of a unit or two in the last place, and the value of a we set out to compute is, therefore, $15/.628 = 23.9$.

4. Direct Use of the Tables. While explaining methods of solution more or less obvious geometrically, we must not overlook an immediate solution of the problem in certain cases by mere inspection of the tables.

For example, the equation

$$\cos x = x$$

has one and only one root, as we see by inspection of the graphs of

$$y = \cos x \quad \text{and} \quad y = x.$$

To find this root, turn to the *Tables*, p. 134. There we find:

RADIANS	DEGREES	COSINES
.7389 ²⁹	42° 20'	.7392
.7418	42° 30'	.7373 ¹⁹

Hence $x = .7391$, corresponding to an angle of 42° 21'. The interpolation by which x was found is a neat problem in elementary algebra. It is left to the student.

The example of § 3 is nearly a case in point. The hyperbolic sine and cosine are defined by the equations (cf. § 8):

$$\text{sh } x = \frac{e^x - e^{-x}}{2}, \quad \text{ch } x = \frac{e^x + e^{-x}}{2}.$$

Tables of values of these functions are given on pp. 120-123 of the *Tables*. The problem in hand thus becomes the following: to solve the equation

$$\text{sh } x = \frac{16}{5}x.$$

From the tables on p. 121 we find:

x	$\frac{1}{15}x$	$\text{sh } x$
.62	.6613	.6605
.63	.6720 ¹⁰⁷	.6725 ¹²⁰

Hence the value of x given by direct interpolation is .626.

EXERCISE

Solve the equation :

$$\cot x = x.$$

5. Successive Approximations. The method of successive approximations is most easily understood by inspection of the graphs of the functions. There are two cases, both illustrated in the accompanying figures. If the slopes of the curves both have the same sign, let

$$C_1: \quad F(x, y) = 0 \quad \text{or} \quad y = f(x)$$

be the one that is less steep,

$$C_2: \quad \Phi(x, y) = 0 \quad \text{or} \quad x = \phi(y)$$

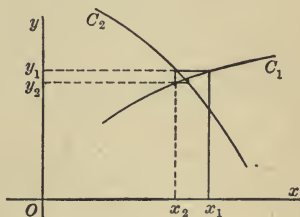
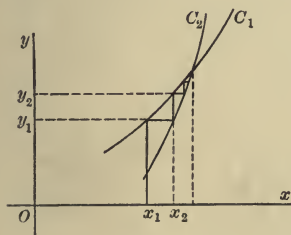

FIG. 118

the other. Then, making the best guess we can to start with, $x = x_1$, compute

$$y_1 = f(x_1)$$

and substitute this value in the equation of C_2 , thus getting the second approximation:

$$x_2 = \phi(y_1).$$

Proceeding with x_2 in the same manner we obtain first y_2 , then x_3 , and so on.

The successive steps of the process are shown geometrically by the broken lines of the figures.

The success of the method depends on the ease with which y can be determined when x is given in the case of C_1 , while for C_2 x must be easily attainable from y . If the curves happened to have slopes numerically equal but opposite in sign, the process would converge slowly or not at all.

The method has the advantage that each computation is independent of its predecessor. An error, therefore, while it may delay the computation, will not vitiate the result.

Example. A beam 1 ft. thick is to be inserted in a panel 10×15 ft. as shown in the figure. How long must the beam be made?

We have:

$$\begin{cases} \sin \phi + l \cos \phi = 15, \\ \cos \phi + l \sin \phi = 10. \end{cases}$$

Hence $\cos^2 \phi - \sin^2 \phi = 10 \cos \phi - 15 \sin \phi$.

Now an expression of the form

$$a \cos \phi - b \sin \phi$$

can always be written as

$$\sqrt{a^2 + b^2} \left(\frac{a}{\sqrt{a^2 + b^2}} \cos \phi - \frac{b}{\sqrt{a^2 + b^2}} \sin \phi \right) = \sqrt{a^2 + b^2} \cos(\phi + \alpha),$$

where $\cos \alpha = \frac{a}{\sqrt{a^2 + b^2}}, \quad \sin \alpha = \frac{b}{\sqrt{a^2 + b^2}}.$

In the present case, then:

$$\cos 2\phi = \sqrt{325} \cos(\phi + \alpha),$$

where $\cos \alpha = \frac{10}{\sqrt{325}}, \quad \sin \alpha = \frac{15}{\sqrt{325}}.$

Thus α is an angle of the first quadrant and

$$\tan \alpha = \frac{3}{2}, \quad \alpha = 56^\circ 16'.$$

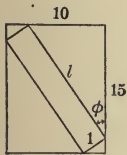

FIG. 119

Our problem may be formulated, then, as follows: To find the abscissa of the point of intersection of the curves:

$$y = \cos 2\phi, \quad y = \sqrt{325} \cos(\phi + \alpha).$$

We know a good approximation to start with, namely:

$$\tan \phi = \frac{2}{3}, \quad \phi = 33^\circ 44'.$$

For this value of ϕ the slopes are given by the equations:

$$\frac{180}{\pi} \cdot \frac{dy}{d\phi} = -2 \sin 2\phi = -2 \sin 67^\circ 28' = -1.8,$$

$$\frac{180}{\pi} \cdot \frac{dy}{d\phi} = -\sqrt{325} \sin(\phi + \alpha) = -\sqrt{325} = -18.$$

Hence we have:

$$C_1: \quad y = \cos 2\phi;$$

$$C_2: \quad y = \sqrt{325} \cos(\phi + \alpha) \quad \text{or} \quad \phi = \cos^{-1} \frac{y}{\sqrt{325}} - \alpha.$$

Beginning with the approximation

$$\phi_1 = 33^\circ 44',$$

we compute $y_1 = \cos 67^\circ 28'.$

Passing now to the curve C_2 , we compute its ϕ when its $y = y_1$:

$$y_1 = \sqrt{325} \cos(\phi_2 + \alpha), \quad \phi_2 = 32^\circ 31'.$$

We now repeat the process, beginning with $\phi_2 = 32^\circ 31'$ and find:

$$y_2 = \cos 65^\circ 02',$$

$$y_2 = \sqrt{325} \cos(\phi_3 + \alpha), \quad \phi_3 = 32^\circ 23'.$$

A further repetition gives $\phi_4 = 32^\circ 22'$, and this is the value of the root we set out to determine.

EXERCISES

1. Solve the same problem for a beam 2 ft. thick.

2. A cord 1 ft. long has one end fastened at a point O 2 ft. above a rough table, and the other end is tied to a rod 2 ft. long. How far can the rod be displaced from the vertical through O and still remain in equilibrium when released?

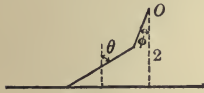

FIG. 120

The equations on which the solution depends are:

$$\begin{cases} 2 \cot \theta + \frac{1}{\mu} = \cot \phi, \\ 2 \cos \theta + \cos \phi = 2. \end{cases}$$

If the coefficient of friction $\mu = \frac{1}{2}$, find the value of ϕ .

3. A heavy ring can slide on a smooth vertical rod. To the ring is fastened a weightless cord of length $2a$, carrying an equal ring knotted at its middle point and having its further end made fast at a distance a from the rod. Find the position of equilibrium of the system.

4. Solve the example worked out in § 3 by the method of successive approximations.

5. In the example worked in the text replace $\cos \phi$ by its value in terms of $\sin \phi$, reduce the resulting equation to the form of an algebraic equation in $\sin \phi$ and solve the latter by Horner's Method.

6. Definite Integrals. Simpson's Rule. If we wish actually to compute the area under a curve numerically, we can make an obvious improvement on the method of inscribed rectangles by using trapezoids, as shown in Fig. 53. We begin as before by dividing the interval (a, b) into n equal parts, and we denote the length of each part by h . The area of the k -th trapezoid is

$$\frac{1}{2}(y_k + y_{k+1})h$$

and hence the approximation thus obtained is

$$A_1 = \left[\frac{1}{2}(y_0 + y_n) + (y_1 + y_2 + \cdots + y_{n-1}) \right] h.$$

This formula is known as the *Trapezoidal Rule*. If the curve is concave downward, as in Fig. 53, A_1 is too small.

Again, if we take n as an even integer and draw tangents at the points $(x_1, y_1), (x_3, y_3), \dots (x_{n-1}, y_{n-1})$, we get some trapezoids as shown in the figure, the area of any one being $2y_k h$, where k is odd. Hence

$$A_2 = 2h[y_1 + y_3 + \dots + y_{n-1}]$$

is an approximation which is too large, and

$$A_1 < A < A_2.$$



FIG. 121

If the curve is concave upward, the inequalities must be reversed.

Finally, a still closer approximation may be obtained by using arcs of parabolas instead of straight lines. If we make the parabola

$$y = a + b(x - x_k) + c(x - x_k)^2$$

go through three successive points, $(x_{k-1}, y_{k-1}), (x_k, y_k), (x_{k+1}, y_{k+1})$, it will follow the arc of the curve more closely in between than the broken lines or the tangents of the preceding approximations do. Now the area under the parabolic arc is

$$\int_{x_k-h}^{x_k+h} [a + b(x - x_k) + c(x - x_k)^2] dx = ax + b \frac{(x - x_k)^2}{2} + c \frac{(x - x_k)^3}{3} \Big|_{x_k-h}^{x_k+h} = 2ah + \frac{2ch^3}{3},$$

and it remains to determine a and c from the above conditions:

$$\begin{aligned} x = x_k, & & y_k = a; \\ x = x_k + h, & & y_{k+1} = a + bh + ch^2; \\ x = x_k - h, & & y_{k-1} = a - bh + ch^2. \end{aligned}$$

Hence $a = y_k, \quad 2ch^2 = y_{k-1} - 2y_k + y_{k+1}.$

Thus the area under the parabolic arc is seen to have the value

$$\frac{1}{3}h(y_{k-1} + 4y_k + y_{k+1}).$$

Adding these areas for $k = 1, 3, \dots, n-1$, we get a new approximation :

$$A_3 = \frac{1}{3}h[y_0 + y_n + 2(y_2 + y_4 + \dots + y_{n-2}) + 4(y_1 + y_3 + \dots + y_{n-1})].$$

This formula is known as *Simpson's Rule*.

If we set
$$u = y_0 + y_n,$$

$$v = y_1 + y_3 + \dots + y_{n-1}, \quad w = y_2 + y_4 + \dots + y_{n-2},$$

we have:
$$A_1 = \frac{1}{2}h(u + 2v + 2w), \quad A_2 = 2hw,$$

$$A_3 = \frac{1}{3}h(u + 4v + 2w).$$

It turns out that
$$A_3 = \frac{2}{3}A_1 + \frac{1}{3}A_2.$$

*Example.** Consider $\int_1^2 \frac{dx}{x}$, and let $n = 10$. Then $h = .1$ and

$$u = 1.5, \quad v = 3.459\ 539\ 4, \quad w = 2.728\ 174\ 6.$$

Hence $A_1 = .693\ 771$, $A_2 = .691\ 908$, $A_3 = .693\ 150$.

The value of the integral is (*Tables*, p. 109):

$$\log 2 = .693\ 147.$$

Thus A_1 differs from the true value by less than 7 parts in about 7000, or one tenth of one percent. A_2 differs by about 12 parts in 7000; while A_3 is in error by less than 3 parts in 600,000, or 1 part in 200,000.

EXERCISES

1. Compute $\int_0^1 e^x dx$; taking $n = 10$, and compare the result with that obtained by integration. Note the tables on pp. 120, 121 of the *Tables*.

* These figures are taken from Gibson's *Elementary Treatise on the Calculus*, p. 331, to which the student is referred for further examples. A more extended treatment of the subject of this paragraph will be found in Goursat-Hedrick, *Mathematical Analysis*, vol. 1, § 100.

2. Compute

$$\int_1^2 \frac{dx}{\sqrt{1+x^4}}$$

3. Obtain an approximate formula for the content of a cask whose bung diameter is a , head diameter, b , and length, l .

$$\text{Ans. } \frac{\pi l}{60} [8a^2 + 4ab + 3b^2].$$

4. If in the preceding question a is only slightly greater than b , the formula may be replaced by the simpler one:

$$\frac{\pi a l (a + 2b)}{12}.$$

7. **Amsler's Planimeter.** A curve may be given graphically, as in naval architecture, when the plans of a ship are made by drawing to scale successive cross-sections. Again, take the indicator diagrams of a steam engine. A pencil or stylus is carried over a sheet of paper, tracing a curve as shown in Fig. 122. The height of the pencil above the axis of abscissas represents the pressure p of the steam on the piston, and the abscissa is proportional to the distance the piston has travelled. Hence the work done in the direct stroke is proportional to*

$$\int_a^b p dx,$$

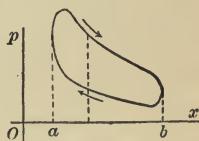

FIG. 122

the ordinate p being given by the upper part of the curve. When the piston returns, negative work is done, and the amount is

$$-\int_a^b p dx \quad \text{or} \quad \int_b^a p dx,$$

* Since x is proportional to the volume of steam behind the piston, we may also write the work as

$$\int p dv.$$

the ordinate now being given by the lower part of the curve. Hence the total work done is proportional to the algebraic sum of these two integrals, namely, the line integral

$$\int p dx \quad \text{or} \quad \int p dv,$$

taken round the complete boundary, *i.e.* the work is proportional to the area enclosed by the curve.

In order to compute such areas one method is that of § 6, and this is the one employed in naval architecture. Another method is by means of integrating machines, integragraphs, or planimeters, as they are called, and this is the one employed for measuring indicator diagrams. There are several such machines in use, one of which, Amsler's Planimeter, we will now describe. It consists of two arms, OP and PQ , jointed at P . One arm is pivoted at O ; the other has a point at its end Q , and Q is made to trace out the curve whose area is sought.

The theory is as follows. Consider the area swept out by the arm PQ . Give to this arm an infinitesimal displacement, its new position being $P'Q'$. The corresponding infinitesimal increment of area, ΔA , is seen to differ from the area $PQSQ'P'P$, where SQ is congruent to the arc PP' and makes the same angle with PQ , by an infinitesimal of higher order. But this latter area is obviously equal to

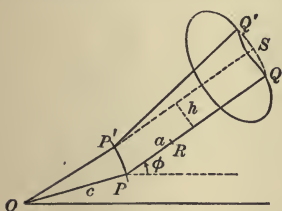

FIG. 123

$$lh + \frac{1}{2}l^2\Delta\phi,$$

where h denotes the perpendicular distance from $P'S$ to PQ and l is the length of PQ . Hence

$$\Delta A = lh + \frac{1}{2}l^2\Delta\phi + \epsilon,$$

where ϵ is an infinitesimal of higher order.

In order to measure h , a disc is attached to the arm PQ at R , the axis of the disc coinciding with that arm.* The disc can

* As a matter of fact, R lies in the line QP produced. This alters nothing in the theory, the distance $PR = a$ merely being taken negative.

turn freely on its axis and the rim of the disc rests on the paper. Now suppose that the arm PQ were brought into its new position $P'Q'$ as follows:

(a) PQ is moved in its own line till P reaches the foot of the perpendicular dropped from P' on its line;

(b) PQ is moved perpendicular to itself till it comes into the position $P'S$;

(c) PQ is rotated about P' as a pivot till it comes into the final position $P'Q'$.

It is now easy to compute the angle through which the disc has turned. During the movement (a) it does not turn at all. During (b) it turns through an angle proportional to $h, h/r$, where r is the radius of the disc; and during (c) through an angle $a\Delta\phi/r$, where a denotes the length PR . The total angle thus obtained, $(h + a\Delta\phi)/r$, will differ from the angle $\Delta\omega$ due to the actual displacement at most by an infinitesimal of higher order, η :

$$\Delta\omega = \frac{h + a\Delta\phi}{r} + \eta.$$

This assumption is an axiom or physical law, borne out by experience, on which the whole theory of this machine rests.

If we eliminate h between the equation for ΔA and that for $\Delta\omega$, we get:

$$\Delta A = lr\Delta\omega + \left(\frac{1}{2}l^2 - al\right)\Delta\phi - lr\eta + \epsilon.$$

Dividing by $\Delta\phi$ and allowing $\Delta\phi$ to approach 0 as its limit, we obtain:

$$D_\phi A = lrD_\phi\omega + \left(\frac{1}{2}l^2 - al\right)$$

and hence

$$dA = lrd\omega + \left(\frac{1}{2}l^2 - al\right)d\phi.$$

The simplest case is that in which, as Q describes the closed curve in question, ϕ steadily increases for one arc from ϕ_0 to ϕ_1 and steadily decreases for the remaining arc from ϕ_1 to ϕ_0 . The total area swept out for the first arc is

$$A_1 = l(\omega_1 - \omega_0) + \left(\frac{1}{2}l^2 - al\right)(\phi_1 - \phi_0).$$

For the second arc, ϕ is decreasing, and the area will be negative:

$$A_2 = lr(\Omega - \omega_1) + (\frac{1}{2}l^2 - al)(\phi_0 - \phi_1).$$

The area of the curve is the algebraic sum of these two areas:

$$A = A_1 + A_2 = lr(\Omega - \omega_0)$$

and hence is proportional to the angle $\Omega - \omega_0$ through which the disc has turned. This angle is read off on the vernier, and the constant multiplier is known or determined for the particular machine that is being used.

It can be shown generally that the area of any closed curve is given by the same formula, provided ϕ comes back to its initial value, the method being merely to divide the area enclosed by the curve up into pieces, for each of which the above determination is applicable. But if the bar PQ makes a complete rotation, so that ϕ changes by 2π , the integral of the last term in the expression for dA will not vanish, but will contribute $(\frac{1}{2}l^2 - al) \cdot 2\pi$ to the result.

8. The Hyperbolic Functions. Certain functions analogous to the trigonometric functions, called the *hyperbolic functions*, have recently come into general use. They go back, however, to Riccati (1757) and are defined as follows:

$$\sinh x = \frac{e^x - e^{-x}}{2};$$

$$\cosh x = \frac{e^x + e^{-x}}{2};$$

$$\tanh x = \frac{\sinh x}{\cosh x},$$

etc. (read "hyperbolic sine of x ," etc.). An abbreviated notation for $\sinh x$, $\cosh x$, $\tanh x$, is $\text{sh } x$, $\text{ch } x$, $\text{th } x$. The graphs of these functions are shown in Fig. 124. The functions satisfy the following functional relations, $\text{sh } x$ and $\text{th } x$ being odd functions, $\text{ch } x$ an even function:

$$\operatorname{sh}(-x) = -\operatorname{sh} x, \quad \operatorname{ch}(-x) = \operatorname{ch} x, \quad \operatorname{th}(-x) = -\operatorname{th} x.$$

Moreover: $\operatorname{sh} 0 = 0, \quad \operatorname{ch} 0 = 1, \quad \operatorname{th} 0 = 0.$

Also: $\operatorname{ch}^2 x - \operatorname{sh}^2 x = 1,$

$$1 - \operatorname{th}^2 x = \operatorname{sech}^2 x, \quad \operatorname{coth}^2 x - 1 = \operatorname{csch}^2 x.$$

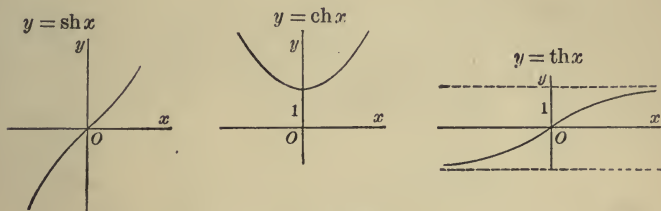

FIG. 124

The Addition Theorems are as follows:

$$\operatorname{sh}(x + y) = \operatorname{sh} x \operatorname{ch} y + \operatorname{ch} x \operatorname{sh} y;$$

$$\operatorname{ch}(x + y) = \operatorname{ch} x \operatorname{ch} y + \operatorname{sh} x \operatorname{sh} y;$$

$$\operatorname{th}(x + y) = \frac{\operatorname{th} x + \operatorname{th} y}{1 + \operatorname{th} x \operatorname{th} y}.$$

From these relations follow at once:

$$\operatorname{sh} 2x = 2 \operatorname{sh} x \operatorname{ch} x,$$

$$\operatorname{ch} 2x = \operatorname{ch}^2 x + \operatorname{sh}^2 x = 2 \operatorname{ch}^2 x - 1 = 1 + 2 \operatorname{sh}^2 x.$$

Derivatives of the Hyperbolic Functions. The derivatives have the values:

$$\frac{d \operatorname{sh} x}{dx} = \operatorname{ch} x, \quad \frac{d \operatorname{ch} x}{dx} = \operatorname{sh} x,$$

$$\frac{d \operatorname{th} x}{dx} = \operatorname{sech}^2 x, \quad \frac{d \operatorname{coth} x}{dx} = -\operatorname{csch}^2 x,$$

etc.

The Inverse Functions. The inverse of the hyperbolic sine is called the antihyperbolic sine:

$$y = \operatorname{sh}^{-1} x \quad \text{if} \quad x = \operatorname{sh} y.$$

Hence

$$x = \frac{1}{2}(e^y - e^{-y}).$$

Solving for e^y , we get:

$$e^y = x \pm \sqrt{1 + x^2}.$$

Since $e^y > 0$ for all values of y , the upper sign alone is possible,

and
$$y = \text{sh}^{-1}x = \log(x + \sqrt{1 + x^2}).$$

The antihyperbolic cosine, however, is multiple-valued, as appears from a glance at its graph, obtained as usual in the case of an inverse function by rotating the graph of the direct function about the bisector of the angle made by the positive coordinate axes:

$$\text{ch}^{-1}x = \log(x \pm \sqrt{x^2 - 1}), \quad x \geq 1.$$

The upper sign corresponds to positive values of $\text{ch}^{-1}x$.

Also:
$$\text{th}^{-1}x = \frac{1}{2} \log \frac{1+x}{1-x}, \quad -1 < x < 1.$$

The derivatives have the values:

$$\frac{d \text{sh}^{-1}x}{dx} = \frac{1}{\sqrt{1+x^2}},$$

$$\frac{d \text{ch}^{-1}x}{dx} = \pm \frac{1}{\sqrt{x^2-1}},$$

$$\frac{d \text{th}^{-1}x}{dx} = \frac{1}{1-x^2}.$$

We thus obtain a close analogy between certain formulas of integration:

$$\int \frac{dx}{\sqrt{a^2 - x^2}} = \sin^{-1} \frac{x}{a}, \quad \int \frac{dx}{\sqrt{a^2 + x^2}} = \text{sh}^{-1} \frac{x}{a};$$

$$\int \frac{dx}{a^2 + x^2} = \frac{1}{a} \tan^{-1} \frac{x}{a}, \quad \int \frac{dx}{a^2 - x^2} = \frac{1}{a} \text{th}^{-1} \frac{x}{a}.$$

A collection of formulas relating to the hyperbolic functions will be found in Peirce's *Tables*, pp. 81-83, and tables for $\text{sh} x$ and $\text{ch} x$ are given there on pp. 119-123.

Relation to the Equilateral Hyperbola. The formula :

$$\int_0^x \sqrt{1-x^2} dx = \frac{1}{2} x \sqrt{1-x^2} + \frac{1}{2} \sin^{-1} x$$

expresses the area $OQPA$ under a circle in terms of the function $\sin^{-1}x$ and enables us, on subtracting the area of the triangle OQP from each side of the equation, to interpret $\sin^{-1}x$ as twice the area of the circular sector OPA .

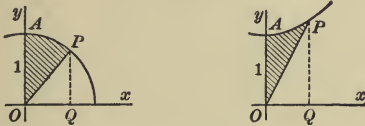

FIG. 125

There is a similar interpretation for $\text{sh}^{-1}x$ with reference to the equilateral hyperbola

$$y^2 = 1 + x^2.$$

$$\begin{aligned} \int_0^x \sqrt{1+x^2} dx &= \frac{1}{2} x \sqrt{1+x^2} + \frac{1}{2} \log(x + \sqrt{1+x^2}) \\ &= \frac{1}{2} x \sqrt{1+x^2} + \frac{1}{2} \text{sh}^{-1}x. \end{aligned}$$

Thus we see that $\text{sh}^{-1}x$ is represented by twice the area of the hyperbolic sector, OPA .

To the formulas for the circle :

$$x^2 + y^2 = 1,$$

$$x = \sin u, \quad y = \cos u,$$

correspond the following formulas for the hyperbola :

$$y^2 - x^2 = 1,$$

$$x = \text{sh } u, \quad y = \text{ch } u,$$

the parameter u being represented geometrically in each case by twice the area of one of the above sectors.

The analogy of the hyperbolic functions to the trigonometric functions is but one phase of the fact that in the domain of complex quantities the trigonometric and the exponential functions and their inverse functions, the antitrigonometric functions and the logarithms are closely related. We have already had occasion to mention the formula:

$$e^{\phi i} = \cos \phi + i \sin \phi, \quad i = \sqrt{-1}.$$

Thus

$$\sin z = \frac{e^{zi} - e^{-zi}}{2i},$$

$$\cos z = \frac{e^{zi} + e^{-zi}}{2},$$

$$\sin^{-1} z = \frac{1}{i} \log (zi \pm \sqrt{1 - z^2}),$$

$$\tan^{-1} z = \frac{i}{2} \log \frac{i+z}{i-z},$$

where $z = x + yi$ is any complex quantity.

The Gudermannian. Let ϕ be defined as a function of x by the relation:

$$\operatorname{sh} x = \tan \phi, \quad \phi = \tan^{-1} \operatorname{sh} x, \quad -\frac{\pi}{2} < \phi < \frac{\pi}{2}.$$

Then ϕ is called the *Gudermannian* of x and is denoted as follows:*

$$\phi = \operatorname{gd} x.$$

We have:

$$\operatorname{sh} x = \tan \phi, \quad \operatorname{ch} x = \sec \phi, \quad \operatorname{th} x = \sin \phi,$$

$$\operatorname{csch} x = \cot \phi, \quad \operatorname{sech} x = \cos \phi, \quad \operatorname{coth} x = \csc \phi;$$

and since

$$e^x = \operatorname{ch} x + \operatorname{sh} x,$$

$$e^x = \tan \left(\frac{\pi}{4} + \frac{\phi}{2} \right), \quad x = \log \tan \left(\frac{\pi}{4} + \frac{\phi}{2} \right).$$

* Also called the *hyperbolic amplitude* and denoted by $\operatorname{amh} x$.

APPENDIX

A. — THE EXPONENTIAL FUNCTION

In Chap. II, § 8, it was shown that, when $x = a > 1$,

$$(1) \quad a^{n'} > a^n \quad \text{if} \quad n' > n,$$

where n and n' are two positive or negative rational numbers. Moreover

$$(2) \quad a^n > 0$$

for all rational values of n ; and

$$(3) \quad \lim_{n \rightarrow +\infty} a^n = +\infty, \quad \lim_{n \rightarrow -\infty} a^n = 0.$$

One further relation, which we will now prove, is important, namely:

$$(4) \quad \lim_{n \rightarrow 0} a^n = 1.$$

When $0 < n < 1$, the curve

$$y = x^n$$

is concave downward, for $D_x^2 y = n(n-1)x^{n-2} < 0$, and so it lies below its tangent. The equation of the latter in the point $(1, 1)$ is:

$$y = n(x-1) + 1.$$

Hence for such values of n , the ordinate of the curve, a^n , is less than the ordinate of the tangent, $n(a-1) + 1$:

$$1 < a^n < n(a-1) + 1, \quad 0 < n < 1.$$

Thus (4) is seen, at least, to be true when n approaches 0 from the positive side.

Similarly it is shown that, when $n < 0$, the curve is concave upward, and

$$1 > a^n > n(a - 1) + 1, \quad n < 0.$$

Hence (4) is true when n approaches 0 from the negative side, too, and the relation is thus established generally.

We can now prove the following theorem.

THEOREM 1. *If ν be any irrational number and n be allowed to approach ν , passing only through rational values, then a^n approaches a limit.*

First, let n approach ν from below, $n < \nu$. Then, by (1), a^n steadily increases as n increases, but never becomes so great as $a^{l'}$, where l' is any rational number greater than ν . Hence, by the Fundamental Principle for the existence of a limit, Chap. XII, § 3, a^n approaches a limit not greater than $a^{l'}$, and in fact here less. For, if l'' be chosen between ν and l' , then $\lim a^n$ is not greater than $a^{l''}$, and $a^{l''} < a^{l'}$. Denote the limit by A . Then

$$(5) \quad \lim_{n \rightarrow \nu^-} a^n = A < a^{l'}, \quad l' > \nu.$$

Here, l' is any rational number greater than ν .

Again, let n approach ν from above, $n = n' > \nu$. Then, by similar reasoning, $a^{n'}$ approaches a limit $A' > a^l$, where l is any rational number less than ν .

$$(6) \quad \lim_{n' \rightarrow \nu^+} a^{n'} = A' > a^l, \quad l < \nu.$$

Finally, to show that $A' = A$. It is clear that A' is not less than A , for (5) gives, when $l' = \infty$:

$$A \leq A'.$$

Since $a^{l'} > A'$ and $a^l < A$, we infer that

$$a^{l'} - a^l > A' - A.$$

Setting $l' = l + h$, we get:

$$0 \leq A' - A < a^l(a^h - 1).$$

Now let l and l' both approach ν . Then h approaches 0 and the right-hand member, therefore, approaches 0. But A and A' do not change with l and l' , and so the value of their difference, being constant, must be 0:

$$0 = A' - A.$$

This completes the proof.

DEFINITION. For an irrational value of the exponent, $n = \nu$, we will define a^ν as

$$\lim_{n \rightarrow \nu} a^n,$$

n passing through only rational values.

Relations (1)–(4) are readily shown to hold when n and n' are one or both irrational.

THEOREM 2. *The function*

$$y = a^x$$

thus defined is continuous.

We wish to prove that, if x_0 is an arbitrary value of x , then

$$\lim_{x \rightarrow x_0} a^x = a^{x_0}.$$

The proof is similar to that of Theorem 1; but the present theorem differs from that one in that x_0 is any number, rational or irrational, and furthermore x , in approaching x_0 , passes through all values, irrational as well as rational.

First let x approach x_0 from below, $x < x_0$. Then it follows as in the proof of Theorem 1 that a^x approaches a limit A :

$$\lim_{x \rightarrow x_0^-} a^x = A < a^{l'}, \quad l' > x_0.$$

where now l' is any number $> x_0$.

Similarly,

$$\lim_{x' \rightarrow x_0^+} a^{x'} = A' > a^{l'}, \quad l' < x_0,$$

And

$$A \leq A'.$$

Hence as before:

$$0 \leq A' - A < a^l - a^l.$$

If we choose l and l' both as rational numbers and set $l' = l + h$ we have:

$$0 \leq A' - A < a^l (a^h - 1),$$

and we now can infer as in the earlier proof that $A' = A$.

It remains, therefore, only to show that $a^{x_0} = A$. Now by (1)

$$a^x < a^{x_0} < a^{x'} \quad \text{if} \quad x < x_0 < x'.$$

Hence

$$\lim_{x \rightarrow x_0^-} a^x \leq a^{x_0} \leq \lim_{x' \rightarrow x_0^+} a^{x'}$$

or

$$A \leq a^{x_0} \leq A.$$

Thus a^{x_0} is seen to $= A$, and this completes the proof.

We have hitherto assumed that $a > 1$. It is shown without difficulty that Theorems 1 and 2 hold when $0 < a \leq 1$.

THEOREM 3. *The relations (A) of Chap. II, § 8, hold when m and n are one or both irrational.*

Consider, for example, the second relation :

$$(a^m)^n = a^{mn}.$$

Let m approach an irrational value, μ , as its limit. Then, since x^n is a continuous function of x when n is rational, we have :

$$\lim_{m \rightarrow \mu} (a^m)^n = \left(\lim_{m \rightarrow \mu} a^m \right)^n = (a^\mu)^n.$$

On the right-hand side,

$$\lim_{m \rightarrow \mu} a^{mn} = a^{\mu n},$$

and hence

$$(a^\mu)^n = a^{\mu n}.$$

If here we allow n to approach an irrational number ν as its limit, we see by Theorems 1 and 2 that

$$(a^\mu)^\nu = a^{\mu\nu}.$$

The proof that

$$(a^m)^n = a^{mn}$$

depends on Theorem 1 alone.

The other relations of (A) are proven in a similar manner.

We have now established rigorously all that was assumed in Chap. IV for the purpose of defining the logarithm and of differentiating the logarithm and the exponential functions. Hence we are entitled to the conclusion of that chapter that x^n is continuous and has a derivative when n is irrational. We have also the material for proving the final statements of Chap. II, § 8, respecting the graph of x^n . If $x = a$, ($0 < a < 1$ or $a > 1$) and $y = b > 0$ are chosen arbitrarily, one and only one value of n can be found for which the curve

$$y = x^n$$

will go through the point (a, b) , namely :

$$b = a^n, \quad n = \log_a b = \frac{\log b}{\log a}.$$

The whole subject of logarithms, exponentials, and fractional exponents can be treated with great simplicity by basing all of these functions on the logarithm, defined as the definite integral :

$$\int_1^x \frac{dx}{x}.$$

Cf. a paper by Bradshaw, *Annals of Mathematics*, ser. 2, vol. 4 (1903), p. 51; or Osgood, *Lehrbuch der Funktionentheorie*, vol. 1, p. 487.

B. — FUNCTIONS WITHOUT DERIVATIVES

In recent years much attention has been paid to discontinuous functions and to functions which, though continuous, still do not have a derivative. Consider, for example, the function

$$y = \sin \frac{1}{x}.$$

When x approaches 0 as its limit, y oscillates between the values $+1$ and -1 , and thus the function, while remaining finite, approaches no limit. It does not even approach one limit when x approaches 0 from the positive side and another limit when x approaches 0 from the negative side. The reader can easily plot the graph roughly.

Let us now form the following function:

$$f(x) = x \sin \frac{1}{x}, \quad x \neq 0;$$

$$f(0) = 0.$$

This function is continuous for all values of x , and its graph is comprised between the lines $y = x$ and $y = -x$. At the point $x = 0$, however, it has no derivative. For, form the difference-quotient:

$$\frac{f(0 + \Delta x) - f(0)}{\Delta x} = \sin \frac{1}{\Delta x}.$$

This variable — the slope of a secant through the origin and a variable point P with the coordinates Δx and $\Delta y = \Delta x \sin \frac{1}{\Delta x}$ — oscillates between $+1$ and -1 , *i.e.* the secant OP turns to and fro, and approaches no limit whatever.

Again, a function may have a first derivative, but no second derivative, as for example:

$$\phi(x) = x^2 \sin \frac{1}{x}, \quad x \neq 0;$$

$$\phi(0) = 0.$$

The foregoing functions have a derivative, to be sure, in general; only for a single point is there trouble. But examples can be adduced of functions that, though continuous for all values of x , do not for one single value of x have a derivative.

In the light of these facts it might seem as if a thoroughgoing revision of all we have said in the early chapters were necessary. The revision, however, is simple. So far as our theorems about derivatives are applied to special functions we have fortified ourselves by showing that the elementary functions actually possess derivatives unless possibly at exceptional points easily recognized. In the statement of the general theorems of Chap. II, § 4, however, it is true that we need to add the requirement that the functions u and v shall possess a derivative. With this supplementary condition Theorems I–V are true in all cases. The proof of Theorem V, however, requires a modification, of which we will speak presently.

Curves. A further restriction on the functions we have treated, which is essential for some of the proofs, is this, that the curve $y=f(x)$ shall have at most a finite number of maxima and minima in a finite interval. The functions $f(x)$ and $\phi(x)$ of the above examples do not have this property. In the neighborhood of the point $x=0$, they both have an infinite number of maxima and minima. We can impose this restriction, however, throughout the Calculus and still the functions will be general enough for most purposes.

With this restriction the proof of Theorem V is valid. Without it, the theorem can still be proven by the aid of the Law of the Mean.

The proof of convergence required to justify the definition of the definite integral, Chap. IX, § 17, rests on this assumption.

SUPPLEMENTARY EXERCISES

A. — INTRODUCTION

Find the slope of each of the following curves.

○ 1. $y = x - x^2$, $x_0 = 1$. *Ans.* -1 .

○ 2. $y = 4 + x^2$, $x_0 = 0$. *Ans.* 0 .

3. $y = \frac{1-x}{x}$, $x_0 = \frac{1}{3}$. *Ans.* -9 .

4. $y = \frac{2x}{(3-x)^2}$, $x_0 = x_0$. *Ans.* $\frac{6+2x_0}{(3-x_0)^3}$.

5. $y = \frac{x^2+a^2}{x+a}$, $x = x_0$. *Ans.* $1 - \frac{2a^2}{(x_0+a)^2} = \frac{x_0^2+2ax_0-a^2}{(x_0+a)^2}$.

6. $y = \frac{x}{3-2x}$. 7. $y = \frac{1}{1-x^2}$.

8. $y = 2x^2 - \frac{1}{x}$. 9. $y = x^3 - 2x + \frac{1}{x-1}$.

10. $y = x + \frac{4}{x} - \frac{1}{x^2}$. 11. $y = \frac{x^6-1}{x^3} + 7$.

Differentiate the following functions by the Fundamental Method of p. 10.

○ 12. $2y = 3x^2 - 2x + 1$. *Ans.* $3x - 1$.

13. $y = x^4 - 3x^3 + x^2 - 9x - 12$. *Ans.* $4x^3 - 9x^2 + 2x - 9$.

○ 14. $y = -10 - 12x^2 + 2x^3$. 15. $y = x(2x - 5)$.

16. $y = x^2(1 - 3x)$. 17. $y = 5 - ax^2 + 7x$.

$$18. \quad y = \frac{2x}{1-x}. \qquad \text{Ans.} \quad \frac{2}{(1-x)^2}.$$

$$19. \quad y = \frac{1}{x^4}. \qquad \text{Ans.} \quad -\frac{4}{x^5}.$$

$$20. \quad y = x^n. \qquad \text{Ans.} \quad nx^{n-1}.$$

$$21. \quad y = \frac{1}{x^m}. \qquad \text{Ans.} \quad -\frac{m}{x^{m+1}}.$$

$$22. \quad xy + x = 7y. \qquad \text{Ans.} \quad \frac{7}{(7-x)^2}.$$

$$23. \quad 5x + 2xy - 4y = 3. \qquad \text{Ans.} \quad \frac{7}{2(2-x)^2}.$$

$$24. \quad y = \frac{ax + b}{cx + d}. \qquad \text{Ans.} \quad \frac{ad - bc}{(cx + d)^2}.$$

B. — DIFFERENTIATION OF ALGEBRAIC FUNCTIONS

An instructor who wishes, after finishing Chapter II, to spend more time on pure drill work in differentiation will probably prefer to introduce the differential at this point. This may be done by taking up §§ 1, 2, 4, and 5 in Chapter V, omitting in § 5 all that relates to transcendental functions. A complete set of the formulas needed for this plan (*v. Chap. V, § 5*) is herewith appended.

$$(A) \quad du = D_x u dx \quad \text{or} \quad \frac{du}{dx} = D_x u.$$

$$\text{I.} \quad d(cu) = cdu.$$

$$\text{II.} \quad d(u + v) = du + dv.$$

$$\text{III.} \quad d(uv) = u dv + v du.$$

$$\text{IV.} \quad d\left(\frac{u}{v}\right) = \frac{v du - u dv}{v^2}.$$

$$1. \quad dc = 0.$$

$$2. \quad \left\{ \begin{array}{l} dx^n = n x^{n-1} dx \\ du^n = n u^{n-1} du. \end{array} \right. \quad \text{or}$$

Differentiate the following functions.

25. $2x^2 - 8x + 3.$

26. $8x^4 - 3x^2 + x - \pi.$

27. $5x^7 - 13x^5 - 9x^4 - x + 1.$

28. $a^3x - 7a^3x - 5a^4.$

29. $(x + 10)(5 - x)^2.$

30. $px^2 - (p + q)x - q.$

31. $\theta(2m - n\theta).$

32. $(a + bx)(ax - b).$

33. $\frac{1}{3}x^3 - 2(a - b)x^2 + 3bx - a + b.$

34. $\frac{x^3}{3} - 2(3x - 5) + x - 1 - \frac{4x - 7}{9}.$

35. $(3 - 2x)^7$

36. $(p + qx)^n.$

37. $x(2 - 3x) - 4(1 - x)^2.$

38. $(2x + 1)(1 - 2x) - 3x(x + 3) + 1.$

39. $6(5 - 4x)^3 - 2(1 - 2x)^4.$

40. $r^4 - 4ar + a^2.$

41. $3t^2 - (a - b)t + 4a - 3b.$

42. $aw^2 - (2a + \beta)w - a\beta.$

43. $3x^{-4} - x^{-2} + x^{-1}.$

44. $4x^5 - \frac{1}{4}x^{-12} - x^{-1}.$

45. $2x - \frac{3}{x}.$

46. $x^2 + \frac{1}{7x^7}.$

47. $r - \frac{1}{r}.$

48. $\frac{s + 1}{s}.$

49. $\frac{2x + 4}{x}.$

50. $\frac{x - x^{-1}}{x} + \sqrt{2.5}.$

51. $x - \frac{1}{x} + \frac{2}{x^3}.$

52. $\frac{1 - x^4}{x^2}.$

53. $\frac{7x^2 - 5x + 3}{x}.$

54. $\frac{7x^2 - 5x + 3}{8}.$

55. $\frac{l + mx^2}{n}.$

56. $\frac{\pi x^4 - x + \sqrt{10}}{x^2}.$

57. $p = \frac{p_0 v_0}{v}.$

Ans. $\frac{dp}{dv} = -\frac{p}{v}.$

58. $\frac{x^2 - 2x + 3}{1 - 2x}.$

59. $\frac{x - 7}{7 - x^3}.$

60. $\frac{as^2 - 2bs + c}{e}$

61. $\frac{t^2 - 1}{t}$

62. $\frac{1}{(1-x)^2}$

63. $\frac{2}{(4-3x)^3}$

64. $\frac{2x}{(5-x)^4}$

65. $\frac{x^2}{(a+bx)^n}$

66. $\frac{2}{(4-x)^2} - \frac{1}{4-x}$

Ans. $\frac{x}{(4-x)^3}$

67. $\frac{a^2 - t^2}{a+t}$

68. $\frac{2s}{1-s^2}$

69. $\frac{1}{2-x} - \frac{4}{1+2x} - \frac{3}{2-3x}$

70. $\frac{a}{a+x} - \frac{2a}{a-x}$

71. $\frac{1}{t} + \frac{2}{1-t^2} - \frac{4}{2+3t^2}$

72. $\frac{s}{1-s} - \frac{4}{s-s^2} + 1$

73. $\frac{x^5(7+2x)^4}{(14-3x)^9}$

Ans. $\frac{14x^4(24x+35)(7+2x)^8}{(14-3x)^{10}}$

74. $\frac{6x}{x^2 - x + 1}$

75. $\frac{3v}{v^2 + 1}$

76. $\frac{x^3 - 8}{x^2 + 2x + 4}$

Ans. 1.

77. $\frac{x^4 - x + 1}{x^2 + x + 1}$

78. $\frac{2x}{(1-2x)^2} + \frac{1}{1-2x} + 3x$

79. $x\sqrt{a^2 - x^2}$

80. $x\sqrt{x^2 + a^2}$

81. $\frac{x}{\sqrt{a^2 - x^2}}$

82. $\frac{\sqrt{x^2 + a^2}}{x+a}$

83. $\sqrt{\frac{a+x}{a-x}}$

84. $\frac{a+x}{\sqrt{2ax-x^2}}$

85. $(a^2 + x^2)\sqrt{a-x}$

86. $(t^2 - 1)\sqrt{1-4t}$

87. $\sqrt[3]{\frac{1-r}{1+r}}$

88. $\sqrt[3]{\frac{a+bx}{c+dx}}$

89. $\frac{\lambda x + \mu}{\sqrt{a - \beta x}}$.
90. $\frac{a + \beta x^2}{\sqrt{2ax - x^2}}$.
91. $x^2 \sqrt{\lambda - \mu x^2}$.
92. $(\beta^2 - x^2) \sqrt{a - \beta x}$.
93. $\sqrt{4 - 5x + x^2}$.
94. $\sqrt{-6 - 5x - x^2}$.
95. $\sqrt{-x}$.
96. $x \sqrt{4 - 5x^2}$.
97. $r^2 \sqrt{-1 + 3r - 2r^2}$.
98. $t \sqrt{-t}$.
99. $\frac{t - t_0}{\sqrt{t_0^2 - t^2}}$.
100. $\frac{3x}{(x+1)\sqrt{4-3x^2}}$.
101. $x - \sqrt{1 + 7x^2}$.
102. $\sqrt{a^2 - x^2} - \sqrt{a^2 + x^2}$.
103. $\frac{x}{\sqrt{a-x} - \sqrt{a+x}}$.
104. $\frac{\sqrt{1-x-x}}{\sqrt{1-x+x}}$.
105. $\sqrt{\frac{x^2 + x + 1}{x^2 - x + 1}}$.
106. $\sqrt{\frac{r}{2r \cos a - r^2}}$.
107. $(2a - 3bx) \sqrt{(a + bx)^3}$. *Ans.* $-\frac{15b^2x\sqrt{a+bx}}{2}$.
108. $(8a^2 - 12abx + 15b^2x^2) \sqrt{(a + bx)^3}$. *Ans.* $\frac{105b^3x^2\sqrt{a+bx}}{2}$.
109. $(2a - bx) \sqrt{a + bx}$.
110. $(8a^2 - 4abx + 3b^2x^2) \sqrt{a + bx}$.
111. $\sqrt{(h^2 - s^2)^3}$.
112. $\sqrt{(a^2 + r^2)^3}$.
113. $\sqrt{(m^2 - y^2)^5}$.
114. $\sqrt{(p^2 + c^2)^5}$.
115. $\frac{\sqrt{v^2 - v_0^2}}{v}$.
116. $\frac{\sqrt{t_0^2 - t^2}}{t^3}$.
117. $\frac{4x + 17}{\sqrt{17 - 8x - 9x^2}}$.
118. $\frac{1 - 4x}{\sqrt{25 + 6x - 12x^2}}$.
119. $\frac{5 - x}{\sqrt{-5 + 10x - x^2}} \left(\frac{5 + 10x - x^2}{5 - 10x + x^2} \right)$. *Ans.* $\frac{600}{(-5 + 10x - x^2)^{\frac{5}{2}}}$.

120. $\frac{x+1}{\sqrt{4+2x+x^2}} \left(\frac{11+4x+2x^2}{4+2x+x^2} \right)$. *Ans.* $\frac{27}{(4+2x+x^2)^{\frac{5}{2}}}$.

121. $\frac{(\rho x - 1)\sqrt{\rho(1+x^2)-2x}}{2\rho}$.
Ans. $\sqrt{\rho(1+x^2)-2x} - \frac{\rho^2-1}{2\rho} \frac{1}{\sqrt{\rho(1+x^2)-2x}}$.

122. $4x^{\frac{1}{2}} - 6x^{-\frac{1}{2}} + x^{\frac{3}{2}}$. 123. $12x^{\frac{3}{2}} - 20x^{\frac{1}{2}} + 8x^{-\frac{3}{2}}$.

124. $\frac{4}{\sqrt{x}} - 8\sqrt{x} + (\sqrt{x})^3$. 125. $\frac{1-t}{\sqrt{t}}$.

126. $\frac{3}{\sqrt[3]{x}} - \frac{7}{x^3} + \frac{1}{x}$. 127. $\frac{1+\sqrt{x}}{\sqrt[3]{x}}$.

128. $\sqrt[3]{x^2} - \sqrt{x^3} + 2(\sqrt[4]{x})^6$. *Ans.* $\frac{2}{3\sqrt[3]{x}} + \frac{3\sqrt{x}}{2}$.

129. $(\sqrt[5]{x})^7 - \frac{1}{(\sqrt[7]{x})^5}$. 130. $\frac{2\sqrt{x^3} - 3\sqrt{x} - 5}{\sqrt{2}}$.

131. $\frac{1+x+x^2}{\sqrt[3]{x}}$. 132. $\frac{x-x^{-1}}{\sqrt{x}}$.

133. $(7-9x)\sqrt{2x}$. 134. $\sqrt{ax} - \frac{a}{\sqrt{bx}}$.

135. $\frac{1-r^2}{\sqrt{mr}}$. 136. $(a^{\frac{2}{3}} - x^{\frac{2}{3}})^3$.

137. $\frac{1+x^{\frac{2}{3}}}{x^{\frac{1}{3}}}$. 138. $\frac{\theta - \alpha}{\sqrt{3\theta}}$.

139. $\frac{2\sqrt{x} - \sqrt[3]{x} - 1}{\sqrt[4]{x}}$. 140. $\frac{\sqrt{4-x^2} - 5}{\sqrt{2-x}}$.

141. $nx^{\frac{m}{n}} - mx^{\frac{n}{m}} + m + n$. 142. $cv^{1.41}$.

143. $(lx^a + mx^b)^2$. 144. $x(1-x^3)^{\frac{7}{5}}$.

145. $(a+x)(a^2-x^2)^{\frac{4}{5}}$. 146. $(a+bx^n)^p$.

147. $\frac{(x^3-1)^{\frac{1}{3}}}{(x^3+1)^{\frac{1}{3}}}$. *Ans.* $\frac{2x^2}{(x^3+1)^{\frac{4}{3}}(x^3-1)^{\frac{2}{3}}}$.

148. $[\sqrt{a-x} - \sqrt{a+x}]^n.$

150. $\frac{x^n - x^{-n}}{n}.$

152. $x^{c+1} + x^{c-1}.$

154. $\frac{x^2}{1 + \sqrt{1-x^2}}.$

156. $\left(\frac{x}{\sqrt{a} - \sqrt{a-x}}\right)^2.$

158. $2x^2 + 5y^2 = 7.$

160. $xy = ax + by.$

162. $x^3y = x_0^3y_0.$

164. $x^3 + y^3 - 3axy = 0.$

166. $y^3 = a^2(x-y).$

168. $2x^2 - 3xy - y^2 = 1.$

170. $x^2y - y^2x + ax^2 - aby = 0.$

172. $x^4 + y^4 + 1 - 6ax^2y^2 = 0.$

149. $[\rho(1+x^2) - 3x]^2.$

151. $\frac{n}{m} x^{n-m}.$

153. $(x^a + x^{-a})^2.$

155. $\frac{x}{x - \sqrt{1+x^2}}.$

157. $\left(\frac{x^3}{1 - \sqrt{1+x}}\right)^3.$

159. $y(x-y) - x^2 = a.$

161. $x + xy = a + b.$

163. $b^2x^2 + a^2y^2 = a^2b^2.$

165. $\frac{x^2}{a^2} - \frac{y^2}{b^2} = 1.$

167. $y^2 = \frac{x-y}{x+y}.$

169. $x^3 - xy + y^4 = 0.$

171. $y^2 - 2ax - 2by + x^2.$

173. $x^5 - 3x^2y + 4xy^2 + 11y^7 = 1.$

C. — DIFFERENTIATION OF TRANSCENDENTAL FUNCTIONS

The further special formulas of p. 95 are required, which may also be written as follows. The student should notice, however, that this form is no more and no less general than that of p. 95.

3. $d \sin u = \cos u du.$

4. $d \cos u = -\sin u du.$

5. $d \tan u = \sec^2 u du.$

6. $d \log u = \frac{du}{u}.$

7. $de^u = e^u du.$

$$8. \quad d \sin^{-1} u = \frac{du}{\sqrt{1-u^2}}.$$

$$9. \quad d \tan^{-1} u = \frac{du}{1+u^2}.$$

To these may be added, if desired:

$$10. \quad d \cos^{-1} u = \frac{-du}{\sqrt{1-u^2}}.$$

$$11. \quad d \operatorname{vers}^{-1} u = \frac{du}{\sqrt{2u-u^2}}.$$

$$12. \quad da^u = a^u \log a \, du.$$

The student should note further the trigonometrical formulas:*

$$(A) \quad \cos^{-1} u = \frac{\pi}{2} - \sin^{-1} u.$$

$$(B) \quad \cot^{-1} u = \tan^{-1} \frac{1}{u} = \frac{\pi}{2} - \tan^{-1} u.$$

$$(C) \quad \csc^{-1} u = \sin^{-1} \frac{1}{u}.$$

$$(D) \quad \sec^{-1} u = \cos^{-1} \frac{1}{u}.$$

Differentiate the following functions.†

$$174. \sin ax. \quad 175. 1 - \cos \pi x. \quad 176. \sin^5 x.$$

$$177. \cos \frac{x}{a}. \quad 178. \csc^2 x. \quad 179. \frac{\cos x}{x}.$$

$$180. \frac{1 + \sin \theta}{1 - \sin \theta}. \quad 181. \sec(\theta - \alpha). \quad 182. \cot \frac{\phi}{2}.$$

$$183. \tan \frac{x}{1-x}. \quad 184. \cos \frac{\pi(\phi_0 - \phi)}{2}. \quad 185. \csc \frac{\theta}{n}.$$

* For further formulas relating to the trigonometric functions, cf. Peirce's *Tables*, pp. 73-80.

† Cf. also the examples on pp. 96-99.

186. $\frac{\sin \phi}{1 - \cos \phi}$. 187. $\frac{1 - \cos \phi}{\phi}$. 188. $\frac{1 + \cos \phi}{\sin \phi}$.
189. $\cos^n \theta$. 190. $\sin^n \pi x$. 191. $\sin ax \cos bx$.
192. $\sin(n - m)\theta$. 193. $\cos(n + m)\phi$. 194. $x^2 \cos ax$.
195. $\frac{\sin mx}{x^2}$. 196. $\frac{\sin \frac{(2n+1)x}{2}}{\sin \frac{x}{2}}$. 197. $\frac{\cos \frac{(2n-1)x}{2}}{\sin \frac{x}{2}}$.
198. $\text{vers } ax$. 199. $x \text{ vers } x$. 200. $\text{vers}^2 ax$.
201. $\sqrt{1 - k^2 \sin^2 \theta}$. 202. $\sqrt{\frac{1 + \cos \theta}{1 - \cos \theta}}$. 203. $\frac{x}{\sqrt{1 + \cos x}}$.
204. $\frac{\sin \theta + \text{vers } \theta}{\sin \theta - \text{vers } \theta}$. 205. $\sqrt{\frac{\text{vers } x}{2 - \text{vers } x}}$. 206. $\frac{\theta}{\sqrt{\text{vers } \theta}}$.
207. $\tan\left(\frac{\pi}{4} - \frac{x}{2}\right)$. 208. $\cot\left(\frac{\pi}{4} - \frac{x}{2}\right)$. 209. $x + \cot x$.
210. $\cot x - \csc x$. 211. $\cot \frac{x}{2}$. 212. $\cot x + \csc x$.
213. $\sin 2x - \frac{\cos 3x}{3} + \sin 3x$. 214. $\cos 5x + \frac{\sin 7x - \cos 9x}{63}$.
215. $\sin 2x = 2 \sin x \cos x$. 216. $\cos 2x = \cos^2 x - \sin^2 x$.
217. $\sin^{-1} \frac{x-1}{2}$. 218. $\cos^{-1} \frac{x}{n}$. 219. $\tan^{-1} \frac{1-2x}{3}$.
220. $\tan^{-1}(2 \tan x)$. 221. $\cos^{-1}(n \sin x)$. 222. $\sin^{-1} ax$.
223. $\cot^{-1} \frac{a-x}{a+x}$. 224. $\tan^{-1}\left(\sin \sqrt{\frac{x}{2a}}\right)$.
225. $\sec^{-1}\left(\frac{x^{\frac{n}{2}}}{a}\right)$. 226. $\text{vers}^{-1} \frac{x}{a}$.
227. $\sin^{-1} \sqrt{\frac{x}{b}}$. 228. $\text{vers}^{-1} \frac{a-x}{a}$.

229. $\tan^{-1} \frac{1-2x}{5x}$. 230. $\sin^{-1} \frac{a-x}{x}$. 231. $\cos^{-1} \frac{1}{x}$.
232. $\sin^{-1} \frac{b+a \cos x}{a+b \cos x}$. *Ans.* $\frac{-\sqrt{a^2-b^2}}{a+b \cos x}$.
233. $\sin^{-1} \left[\frac{\sqrt{a^2-b^2} \sin x}{a+b \cos x} \right]$. 234. $\tan^{-1} \left[\sqrt{\frac{a-b}{a+b}} \tan \frac{1}{2} x \right]$.
235. $\tan^{-1} \left[\frac{\sqrt{a^2-b^2} \sin x}{b+a \cos x} \right]$. *Ans.* $\frac{\sqrt{a^2-b^2}}{a+b \cos x}$.
236. $\log(2-3x)$. 237. $\log(a-x)$. 238. $\log x^2$.
239. $\log(1+x^2)$. 240. $\log \frac{1-x}{x}$. 241. $\log(x+2x^2)$.
242. $\log \sqrt{1+\cos \theta}$. 243. $\log \frac{\sqrt{x}-\sqrt{a-x}}{\sqrt{a}}$.
244. $\log(a-x)^2$. 245. e^{-x} .
246. e^{ax+b} . 247. e^{1-x^2} .
248. e^{-2x} . 249. $e^{x \log a}$. 250. a^{-x^2} .
251. $\sqrt{e^x}$. 252. $\sqrt[3]{a^{-x}}$. 253. $\sqrt[3]{8^t}$.
254. $e^{\sqrt{x}}$. 255. $e^{mx} - e^{-mx}$. 256. $\log \log x$.
257. $\log \frac{1+e^x}{e^x}$. 258. e^{m-x} . 259. $(10^{1+t})^2$.
260. $e^{-nt} \cos(at-\beta)$. 261. $e^{-x} \log ax$. 262. $e^{x \sin x}$.
263. $\frac{a^x - a^{-x}}{a^x}$. 264. $a^{\log \phi}$. 265. 10^{-x^3} .
266. $\sin \log x$. 267. $\log \cos^n x$.
268. $\log(a + \sqrt{a^2+x^2})$. 269. $a^x \log a$.
270. $e^{\sin^{-1} x}$. 271. $\sqrt{10^x}$.
272. $\frac{1}{\sqrt{a}} \log \frac{\sqrt{a+bx} - \sqrt{a}}{\sqrt{a+bx} + \sqrt{a}}$, $a > 0$. *Ans.* $\frac{1}{x\sqrt{a+bx}}$.
273. $\frac{2}{\sqrt{-a}} \tan^{-1} \sqrt{\frac{a+bx}{-a}}$, $a < 0$. *Ans.* $\frac{1}{x\sqrt{a+bx}}$.

$$274. \log \frac{a + \sqrt{a^2 \pm x^2}}{x}. \quad \text{Ans. } \frac{-a}{x\sqrt{a^2 \pm x^2}}.$$

$$275. \log \sqrt{\frac{\sqrt{x+a} + \sqrt{x-a}}{\sqrt{x+a} - \sqrt{x-a}}}. \quad \text{Ans. } \frac{1}{2\sqrt{x^2 - a^2}}.$$

$$276. \log(\sqrt{21 - 8x + x^2} + x - 4). \quad \text{Ans. } \frac{1}{\sqrt{21 - 8x + x^2}}.$$

$$277. \log(\sqrt{-12 + 16x + 4x^2} + 2x + 4). \quad \text{Ans. } \frac{1}{\sqrt{-3 + 4x + x^2}}.$$

$$278. (\sin ax)^x. \quad 279. (1+x)^{\frac{1}{x}}. \quad 280. (\log x)^{x^2}.$$

$$281. \left(\cos^{-1} \frac{x}{a}\right)^{\tan x}. \quad 282. (\cos x)^{x^3}. \quad 283. (4 - \tan x)^{\frac{1}{x}}.$$

$$284. (a^2 + x^2)^x. \quad 285. (\tan^{-1} x)^{\sin^{-1} x}. \quad 286. r^{r^2}.$$

$$287. (\log \cos x)^x. \quad 288. (\log \tan x)^{\frac{1}{x}}. \quad 289. x^{\log x}.$$

$$290. x = \frac{c}{2} \left(e^{\frac{y}{c}} + e^{-\frac{y}{c}} \right). \quad \text{Ans. } \frac{dy}{dx} = \frac{2}{e^{\frac{y}{c}} - e^{-\frac{y}{c}}}, \text{ or } \frac{\pm c}{\sqrt{x^2 - c^2}}.$$

$$291. e^x \cos^{-1} y - (1-x) \log(1+y) = 1.$$

$$\text{Ans. } \frac{dy}{dx} = \frac{e^x \cos^{-1} y + \log(1+y)}{e^x \sqrt{1+y} + (1-x) \sqrt{1-y}} (1+y) \sqrt{1-y}.$$

$$292. r^2 = a^2 \cos 2\theta. \quad 293. x^y - y^x = 0. \quad 294. \theta = \sin(\theta + \phi).$$

$$295. x = y \sin y. \quad 296. y - k \sin y = a + x.$$

$$297. \tan^{-1} x - \tan^{-1} y = ax + by. \quad 298. xe^y - y \log x = 1.$$

$$299. a \sin(r\theta) = b\theta + r. \quad 300. re^r = \theta \sin \theta.$$

$$301. x^{\frac{2}{3}} + y^{\frac{2}{3}} = a^{\frac{2}{3}}. \quad 302. \sqrt{x} + \sqrt{y} = \sqrt{a}.$$

$$303. \left(\frac{x}{a}\right)^{\frac{2}{3}} - \left(\frac{y}{b}\right)^{\frac{2}{3}} = 1. \quad 304. (\log x)^y - y \cos \pi x = 1.$$

$$305. \begin{cases} x = a \cos^5 \theta, \\ y = b \sin^5 \theta. \end{cases} \quad 306. \begin{cases} x = \tan \theta - \theta, \\ y = \cos \theta. \end{cases}$$

$$307. \begin{cases} x = a + bt + ct^2, \\ y = a' + b't + c't^2. \end{cases}$$

$$308. \begin{cases} x = a(3t - t^3), \\ y = a(5t + t^5). \end{cases}$$

$$309. \begin{cases} x = \frac{1 - \lambda^2}{1 + \lambda^2} a. \\ y = \frac{2\lambda}{1 + \lambda^2} a. \end{cases}$$

$$310. \begin{cases} x = \frac{1 + t^3}{t}, \\ y = \frac{1 - t^3}{t^2}. \end{cases}$$

311. Find the slopes of the curves in Exs. 308–310 where these curves cross the axis of x .

312. Remembering that

$$1 + r + r^2 + \dots + r^n = \frac{1 - r^{n+1}}{1 - r},$$

show that

$$1 + 2r + 3r^2 + \dots + nr^{n-1} = \frac{1 - (n+1)r^n + nr^{n+1}}{(1-r)^2}.$$

313. Using the result of the preceding question, obtain a formula for the sum:

$$1 + 2^2r + 3^2r^2 + \dots + n^2r^{n-1}.$$

314. In the formula

$$p = \frac{RT}{v-a} - \frac{c}{T(v+b)^2},$$

R , a , b , and c are constants and p , v , and T denote pressure, volume, and temperature, respectively.

(a) Considering T as constant, find the derivative of p with respect to v .

(b) Considering v as constant, find the derivative of p with respect to T .

(c) Considering p as constant, find the derivative of T with respect to v .

D. — APPLICATIONS

Find the value of x for which y is a maximum or a minimum in each of the following cases.

315. $12y = x^3 - 6x^2$, $x > 0$.

316. $ay = x^7 - 35x^5$, $x < 0$.

317. $y = x^5 - 15x^3 + 25, x > 0.$ 318. $y = x^5 - 2x^3 - \frac{7}{5}x, x > 1.$

319. $y = \frac{9}{3 + x^2}.$

320. $y = \frac{-12}{4 + 7(2 - x)^2}.$

321. $y = \frac{x^2 + 1}{x}.$

322. $y = \frac{48 + x^4}{x}.$

323. $y = \frac{13 - 4x + x^2}{x - 2}, x > 2.$ 324. $y = \frac{(x + 1)^2}{2x - 3}, x > 3.$

325. Divide 12 into two such parts that the product of one of these parts by the square of the other is as large as possible.

326. Divide a into two such parts that the product of one of them by the cube of the other is as large as possible.

327. Divide 30 into two such parts that twice the cube of one of them increased by three times the square of the other may be as large as possible.

328. If the strength of a beam is proportional to its breadth and the square of its depth, find the dimensions of the strongest beam that can be cut from a log of circular cross-section.

329. What is the shortest distance from the point $x = 12, y = 0$ to the curve $y^2 = 4x$?

330. What point of the curve $y = x^{\frac{3}{2}}$ is nearest to the point $x = 1, y = 0$?

331. Tangents are drawn to the parabola

$$y^2 = a^2 - 2ax.$$

What one of them cuts off the smallest triangle from the first quadrant?

332. In the foregoing problem, what tangent has the shortest segment in the first quadrant?

333. A trough is to be made of a long rectangular-shaped piece of copper by bending up the edges so as to give a rectangular cross-section. How deep should it be made, in order that its carrying capacity may be as great as possible?

334. A block of stone is to be drawn up an inclined plane by a rope. Find the angle that the rope should make with the plane in order that the tension may be as small as possible.

335. Show that the abscissa of that point of the curve $y = \log x$ which is nearest to the origin is given by the equation:

$$\log \frac{1}{x} = x^2.$$

336. Find the value of x from the foregoing equation correct to two significant figures.

Suggestion. Tabulate for some trial values of x the values of x^2 , $1/x$, $\log 1/x$, read off directly from convenient tables, such as Huntington's *Four Place Tables*.

337. Assuming the density of water to be given from 0° to 30° C. by the formula

$$\rho = \rho_0(1 + \alpha t + \beta t^2 + \gamma t^3),$$

where ρ_0 denotes the density at freezing, t the temperature, and

$$\alpha = 5.30 \times 10^{-5}, \quad \beta = -6.53 \times 10^{-6}, \quad \gamma = 1.4 \times 10^{-8},$$

show that the maximum density occurs at $t = 4.08^\circ$.

Determine by inspection whether the following functions are increasing algebraically or decreasing as the independent variable increases.

338. $a - x$.

339. $t(t - c)$, $t > c$.

340. $\frac{4}{1+x}$, $x > -1$.

341. $\frac{1}{a^2 + x^2}$, $x > 0$.

342. $x(x-1)(x-2)$, $x > 2$.

343. $x(1-x^2)$, $x > 1$.

344. $\frac{1}{1+t^2}$, $t < 0$.

345. $\frac{1+t}{1-t}$, $0 < t < 1$.

346. $\frac{a^2 - x^2}{a^3 + x^3}$, $0 < x < a$.

347. $\frac{x}{a-x}$, $0 < x < a$.

348. $x^3 - bx$, $b < 0$.

349. $t(1+t^2)$.

350. $(x-2)(x-7)(x-20)$, $x < 2$.

351. $a^4 + 5a^2x^2 + 7x^4$.

Are the following functions increasing or decreasing?

352. $y = \frac{4+x}{2+3x}$.

353. $s = \frac{7+3t}{4+5t}$.

354. $u = \frac{5-x}{4+2x}$.

355. $y = \frac{\alpha + \beta x}{\gamma + \delta x}$.

356. $y = \frac{2x}{1+x^2}, x = 0$.

357. $y = \frac{1+x^2}{x}, x = \frac{1}{2}$.

358. $y = x - x^3 + x^4, x = 1$.

359. $s = 100t - 16t^2, t = 3$.

360. $y = x \sin x, x = \pi$.

361. $y = x - 2 \sin x, x = 0$.

362. $y = 2 \sin x - 3 \cos 2x, x = \frac{1}{2}\pi$.

363. $y = x \log x, x = 1$.

In what intervals are the following functions increasing, and in what decreasing?

364. $y = 10 - 3x + x^3$.

365. $u = -5 + 30x^2 - 20x^3$.

366. $y = x^4 - 10x^3 - 41$.

367. $s = t^3 + t^4 + 8$.

368. $y = 2x^3 - 15x^2 + 36x - 1$.

369. $r = 3\theta^3 + 5\theta - 11$.

370. $y = \frac{x}{a^2 + x^2}$.

371. $y = x + \sin x$.

372. $y = \sin x + \cos x$.

373. $y = e^{-x} \sin x$.

374. $x = A \sin (nt - \gamma), A > 0, n > 0$.

375. $x = C \cos (nt + \epsilon), C > 0, n > 0$.

376. $x = e^{-at} \sin (nt - \epsilon), n > 0$.

In what intervals are the following curves concave upward, and in what downward?

377. $y = x^3 - 9x^2 + 7x - 3$.

378. $y = 2x^3 + 3x^2 - 1$.

379. $y = 3x^5 + 5x^4 - 2x + 7$.

380. $y = x^{11} - x^{10}$.

381. $y = ax^3 + bx^2 + cx + d$.

382. $y = ax^2 + bx + c$.

383. $y = 2x^6 - 9x^5 + 10x^4 - x$.

384. $y = \frac{x^8}{56} - \frac{x^7}{42} + \frac{x^6}{30}$.

385. $y = x + \cos x$.

386. $y = \sin x - x$.

387. $y = x \log x.$

388. $y = xe^{-x}.$

389. $y = \frac{\log x}{x}.$

390. $y = x^x.$

391. $y = e^{-x^2}.$

392. $y = \log \cos x.$

393. Plot the curves which represent the functions in Exs. 384–392.

394. A point moves along the hyperbola $xy = 100$ and its ordinate increases uniformly at the rate of 20 ft. a sec. Find how fast the abscissa is decreasing when $y = 15$.

395. A point moves along the curve $r = 1/\theta$ at the rate of 6 ft. a sec. How fast is radius vector turning when $\theta = 2\pi$?

396. If a drop of rain, as it moves through moist air, receives accretions so that its radius is increasing at the rate of c cm. a sec., at what rate is its volume increasing when its radius is a cm.?

397. A point describes the cardioid $r = 2a(1 - \cos \theta)$ with uniform velocity c . How fast is its distance from the pole $r = 0$ changing when $\theta = \frac{1}{2}\pi$?

398. A man in a train that is running at full speed looks out of the window in a direction perpendicular to the track. If he fixes his attention successively for short intervals of time on objects at different distances from the train, show that the rate at which he has to turn his eyes to follow a given object is inversely proportional to its distance from him.

399. A point describes the circle $x^2 + y^2 = 25$ with a velocity of 12 ft. a sec. Find the component velocity along the axis of x when $x = 4$.

400. At what rate is the ordinate of the curve $y = x - x^3$ changing when $x = 1$, if the abscissa is increasing at the rate of 10 metres a second? Is the ordinate increasing or decreasing?

401. A man walks across the floor of a semicircular rotunda 100 ft. in diameter, his speed being 4 ft. a sec., and his path the radius perpendicular to the diameter joining the extremi-

ties of the semicircle. There is a light at one of the latter points. Find how fast the man's shadow is moving along the wall of the rotunda when he is half way across.

402. Water is flowing out of a hemispherical bowl from an opening at the lowest point. If the rate of efflux is c cu. cm. a sec. when the level of the water is half way between the hole and the centre of the bowl, how fast is the level falling?

Suggestion. Compare the volume of water that flows out in Δt seconds with the fall in level, Δx , and thus compute directly $\lim \Delta x / \Delta t$.

E. — ERRORS OF OBSERVATION *

Let x be an observed quantity and y a second quantity, dependent on x , to be computed:

$$y = f(x).$$

An error of Δx in observing x , the true value being x_0 , will give rise to an error Δy in the computed value, where

$$\Delta y = f(x_0 + \Delta x) - f(x_0).$$

Now we are concerned only with an approximate value of Δy and hence any other quantity that differs from Δy by less than the error in Δy which we are willing to admit is an equally faithful representative of the error in y . Such a representative is found for most of the cases that arise in practice in dy , since, if the derivative $f'(x)$ is finite for $x = x_0$ and $\neq 0$, Δy and dy will differ from each other only by a small percentage of either, when Δx is small, that is:

$$\lim_{\Delta x \rightarrow 0} \frac{\Delta y - dy}{dy} = 0.$$

DEFINITION. — By the *absolute error* in y is meant

$$dy = f'(x_0) dx,$$

* I am indebted to Dr. Harvey N. Davis for the problems in this section.

the error in x being denoted by dx . The *relative error* is defined as

$$\frac{dy}{y}.$$

Since the relative error is $d \log y$, it is often better to take the logarithm of each side of the equation $y = f(x)$ before differentiating.

If y depends on several variables, x, t, \dots , it is frequently desirable to consider the errors in y arising separately from the errors in x, t, \dots ; *i.e.* to hold all but one of the letters x, t, \dots fast and allow that one alone to vary.

By the *coefficient of propagation* is meant the multiplier λ when the error equation is written in one of the four standard forms:

$$dy = \lambda_1 dx, \quad \frac{dy}{y} = \lambda_2 \frac{dx}{x}, \quad dy = \lambda_3 \frac{dx}{x}, \quad \frac{dy}{y} = \lambda_4 dx.$$

Thus, when both errors are absolute errors, $\lambda = \lambda_1 = f'(x_0)$; when both errors are relative errors, $\lambda = \lambda_2 = x_0 f'(x_0) / f(x_0)$; and so on.

Example. The length and the diameter of a cylindrical bar are nearly 25 cm. and 2 cm., respectively. Find the absolute and the relative errors in the volume due to an error of $\delta = .02$ cm. in measuring the diameter.

Here,
$$V = \frac{1}{4} \pi D^2 H.$$

Hence the absolute error is

$$dV = \frac{1}{2} \pi DH \delta = 1.6 \text{ cu. cm.}$$

The relative error may be found by dividing each side of the equation by $V = \frac{1}{4} \pi D^2 H$;

$$\frac{dV}{V} = 2 \frac{\delta}{D} = .02,$$

or 2 per cent. Had the relative error been the only thing to be computed, we should have proceeded more simply as follows:

$$\log V = \log \frac{1}{4} \pi H + 2 \log D,$$

$$\frac{dV}{V} = 2 \frac{dD}{D} = \frac{2\delta}{D}.$$

403. In the case of a sphere find the absolute error in the volume produced by an error of .01 cm. in the radius, r , (a) when $r = 1$ cm.; (b) when $r = 50$ cm.

Ans. (a) .126 cu. cm.; (b) 314 cu. cm.

404. In the two cases of the preceding problem, find the relative error in the volume due to an error of 2 per cent in determining r .

Ans. 6 per cent in both cases.

405. What is the allowable absolute error (a) in the measurement of the longest, and (b) in the measurement of the shortest dimension of a rectangular block 10 cm. by 5 cm. by 2 cm., if its volume is to be determined within one-fifth of one per cent? Assume in each case that the other measurements are correct.

Ans. (a) .02 cm.; (b) .004 cm.

406. What is the allowable relative error in measuring (a) the diameter of the base (5 cm.) and (b) the height (10 cm.) of a right circular cone, if its volume is to be determined within a fifth of one per cent? Assume in each case that the other measurement is correct.

407. What conditions must the dimensions of a right cylinder satisfy if, for a given error in the volume, the allowable absolute errors in the length are equal?

408. A desired quantity, S , is the sum (or difference) of two measured quantities, a and b . Show that the coefficients of propagation for relative errors are numerically as the quantities a and b , and that the allowable relative errors are inversely as a and b .

409. What is the relation between the allowable absolute errors in the last question?

410. If $y = a - b$ and $3a = 4b$, what relative error in y is caused by an error of one per cent in a ?

411. A flag pole subtends, at a point 40 ft. from its base, an angle of 60° . What relative error in the computed height is caused by an error of 1° in the observed angle?

412. What relative error is caused by an error of one per cent in the distance ?

413. Would the computed height in Ex. 411 be more or less sensitive to the error in the observed angle if the observer moved farther away from the pole ?

414. At what distance from the pole is the computed height least sensitive to errors in the observed angle ?

415. If, in Ex. 411, a minute of arc in the angle and a tenth of one per cent in the distance from the foot of the pole are degrees of accuracy in the measurement about equally easy to obtain, where should the observer stand ?

416. Discuss the accuracy of the determination of the ordinate of a point on a given circle centred at the origin when the abscissa is measured.

417. A surveyor has a measured base line of 100 miles and finds that the angles between it and a distant mark are 60° and 45° . With what absolute accuracy must each of the three measurements be made if no one of the resulting errors in the shorter of the unknown distances is to exceed one hundredth of one per cent ?

418. A steel cylinder is 8 cm. long and 6 cm. in diameter, and it weighs 20 gr. The moment of inertia of such a cylinder about its geometric axis being

$$I = \frac{Mr^2}{2},$$

what is the allowable absolute error in the measured diameter if I is desired within one hundredth of one per cent ?

419. The moment of inertia of a right cylinder about a line through its centre perpendicular to the axis of figure is

$$I = M \left(\frac{r^2}{4} + \frac{l^2}{12} \right),$$

where l is the whole length. If the diameter of the cylinder

in Ex. 418 is known to one part in 600, with what relative accuracy should l and M be known, to give equally small errors in I ?

420. A certain magnetic measurement (in Gauss's "B position") leads to the formula

$$\frac{M}{H} = (s^2 + l^2)^{\frac{3}{2}} \tan \alpha,$$

and in a certain case s was 35 cm., l was 4 cm., and α was 4° . If M/H is to be determined within a fifth of one per cent, what is the allowable absolute error (a) in s , and (b) in l ?

421. A similar magnetic measurement (in Gauss's "A position") leads to the formula

$$\frac{M}{H} = \frac{(s^2 - l^2)^2}{2s} \tan \alpha,$$

and in a certain case s was 35 cm., l was 4 cm., and α was 8° . What relative error in M/H would be caused by an error of three hundredths of one per cent in s ? What is the corresponding relative error in l ?

422. When a magnet or pendulum is swinging through a viscous medium, like air, it is found that the successive amplitudes form a geometric series: that is, if any amplitude be called a_0 , those following are

$$a_1 = a_0/k, \quad a_2 = a_0/k^2, \quad \cdot \quad \cdot \quad \cdot, \quad a_m = a_0/k^m,$$

where $k > 1$ is a constant of the apparatus. If $\log k$ (called the "logarithmic decrement") be denoted by λ , then

$$\lambda = \frac{\log a_0 - \log a_m}{m}.$$

Assuming that a_0 is correct, but that every subsequent amplitude a_m is subject to an absolute error δ independent of m , find the absolute error in λ in terms of a_0 , k , and m , and show that it is a minimum when m satisfies the equation $k^m = e = 2.718$, so that under the conditions of this problem one should use, in determining λ , that a_m which is nearest $a_0/2.718$ to get the best results.

423. Assuming that in the preceding problem both a_0 and a_m are subject to the absolute error δ , and that the resulting error in λ is the sum of the absolute values of the errors which would be produced by the errors in a_0 and a_m acting separately, show that the best value of m is given by the equation

$$\log k_m = 1 + k^{-m}.$$

424. Solve the foregoing equation by approximate methods and show that k^m or a_0/a_m should have the value 3.59.

425. In Ex. 423 assume that the error in λ has its "most probable value," which is the square root of the sum of the squares of the errors which would be produced by the errors in a_0 and in a_m acting separately. Show that the best value for a_0/a_m is now 3.03.

426. The period of a pendulum varies inversely as the square root of the force of gravity, g , at the place of observation. With what percentage accuracy must the period be observed if g is to be determined to one part in ten thousand?

427.* If the period of such a pendulum is very nearly one second, the period can be compared with that of the pendulum of a clock beating seconds. Suppose that the two are beating exactly together at the time t_1 , that the unknown pendulum gains on the other, and that they beat together again at the time t_2 . Then in exactly $n = t_2 - t_1$ sec. the unknown pendulum has made exactly $n + 1$ swings, and its period is $n/(n + 1)$ sec. How large must n be to make an error of 1 sec. in determining n allowable under the conditions of the preceding question?

428. If the n of the last question is 45, what percentage error in the period would result from an error of 2 sec. in determining n ?

429. If the allowable error in the period is a tenth of one per cent, how great must n be to make an error in it of 10 sec. allowable under the conditions of Ex. 427?

* The solutions of Exs. 427-429 belong in a course in physics, for the mathematical processes involved are exceedingly simple. They are inserted merely to indicate more clearly the bearing of such work as is here given in errors of observation, on the actual problems that arise in practice.

F. — INTEGRATION

Integrate each of the following functions with respect to x .

430. $12x^5 - 10x^4 - 16x^3 + 2x$. 431. $x^7 - 5x^6 + x + 1$.
432. $ax^b - bx^a + ab$. 433. $(m+n)x^{\frac{m}{n}} + m - n$.
434. $1 - 4x - x^3 + 11x^{10}$. 435. $-3 + x + \frac{1}{2}x^2 - \frac{1}{3}x^3$.
436. $4x^9 - 13x^6 - 5x^3 - 1$. 437. $\frac{1}{7}x^7 - \frac{1}{4}x^2 + 2x + 1$.
438. $\frac{9 - 3x + x^2}{12}$. 439. $\frac{x^3 - 5x^2 + x - 1}{3x}$.
440. $x^2 + \frac{1}{x} - 1$. 441. $3 - \frac{1}{x} + x^3$.
442. $x^{\frac{5}{2}} + x^{-\frac{5}{2}} + 1$. 443. $x^{\frac{1}{2}} + x^{-\frac{1}{2}} - 2$.
444. $\sqrt{x} - \frac{1}{\sqrt[3]{x}} + \frac{1}{x}$. 445. $x^{-\frac{3}{2}} - x^{-1} + x^{-\frac{1}{2}}$.
446. $\frac{1}{\sqrt[3]{x^2}} - \frac{3}{\sqrt[3]{x^4}} - \frac{7}{x} + 3$. 447. $\frac{a + bx + cx^2}{(a+b)x^2}$.
448. $9x^{\frac{4}{3}} - \frac{2}{x^{\frac{1}{3}}} - \frac{4}{x^{\frac{3}{7}}}$. 449. $\frac{1 - x^3}{2\sqrt[3]{x^2}}$.
450. $\frac{1 + \sqrt{x}}{x} - (1+x)\sqrt{x}$. 451. $x(a + b\sqrt{2x})$.
452. $(5 - \sqrt{x})(x + 3\sqrt{x})$. 453. $(a + bx)\sqrt{cx}$.
454. $(\sqrt{c} - \sqrt{2x})^2$. 455. $\left(\sqrt[3]{ax} - \frac{1}{\sqrt[3]{ax}}\right)^3$.
456. $(a^2 - x^2)\sqrt{7ax}$. 457. $(\sqrt{a} - \sqrt{3bx})^3$.

Evaluate the following integrals.

458. $\int \left(\frac{2}{1-x} - \frac{1}{1+x} \right) dx$. 459. $\int \left(\frac{2}{1+3t} - \sqrt{2t} \right) dt$.
460. $\int \frac{dy}{\sqrt{1-ay}}$. 461. $\int \left\{ \frac{\sqrt{a+s}}{\sqrt{a}} - \frac{1}{\sqrt{1+\frac{s}{a}}} \right\} ds$.

462. $\int \frac{x dx}{a-x}$

463. $\int \left(\frac{a}{a+t} - \frac{2a}{a-3t} \right) dt$

464. $\int \frac{a^2+x^2}{a+x} dx$

465. $\int \frac{x^3-2x^2+x-1}{x-1} dx$

✓ 466. $\int (a \sin 2x - b \cos 3x) dx$ 467. $\int e^{-a^2x} dx$

468. $\int \left(\frac{4}{x+1} - 1 \right)^3 dx$

469. $\int \left(\frac{2}{2-x} - x \right)^2 dx$

470. $\int \left(e^{t \cos a} - \frac{1}{t} \right) dt$

471. $\int \frac{e^{cx} - e^{-cx}}{c} dx$

✓ 472. $\int \cot \frac{x}{a} dx$ ✓ 473. $\int \sin \frac{\pi x}{2} dx$

474. $\int \sec ax dx$

475. $\int \csc \frac{x}{2} dx$

✓ 476. $\int \sec^2 2x dx$

477. $\int \left(1 + \cot^2 \frac{x}{2} \right) dx$

478. $\int \cos(nt - \epsilon) dt$

479. $\int e^{-\frac{1}{x}} \frac{dx}{x^2}$

480. $\int \tan^3 x \sec^2 x dx$

✓ 481. $\int \frac{\csc^2 x dx}{\sqrt{\cot x}}$

482. $\int \cos^{-1} x \frac{dx}{\sqrt{1-x^2}}$

483. $\int \frac{\tan^{-1} \frac{x}{a}}{a^2+x^2} dx$

484. ✓ $\int e^x \cos e^x dx$

✓ 485. $\int e^{-x}(1-e^{-x})^3 dx$

486. ✓ $\int \sqrt{e^x+2} dx$

487. ✓ $\int \frac{dx}{e^x - e^{-x}}$

488. $\int t(e^{\kappa t^2} - e^{-\kappa t^2}) dt$

✓ 489. $\int \frac{\sqrt{a^4+x^4}}{x^3} dx$

490. $\int (a - 3bx)^{\frac{3}{2}} dx.$

492. $\int \frac{\sqrt{a} ds}{\sqrt{c + 3as}}.$

494. $\int \left(\frac{r+a}{b}\right)^3 dr.$

✓ 496. $\int [(ax)^{b-1} - (ax)^{-b+1}] dx.$

498. $\int \frac{1}{3} \tan \frac{2x}{3} dx.$

✓ 500. $\int a \cos \frac{2x-3a}{5} dx.$

502. $\int (2e^{-r} - e^{r\sqrt{a}}) dr.$

504. $\int (a+b-ax)^2 dx.$

506. $\int x^2 \left(\frac{1}{1+x} - 4\right) dx.$

✓ 508. $\int x(a^2 - x^2)^{\frac{3}{2}} dx.$

510. $\int \frac{x^2 dx}{\sqrt{x^3 - a^3}}.$

✓ 512. $\int x(1+ax^2)^{\frac{5}{2}} dx.$

514. $\int \frac{t^5 dt}{1+ct^6}.$

516. $\int x^2(2a-nx^3)^3 dx.$

491. $\int \sqrt{-x} dx, (x < 0).$

493. $\int (k-r)^{m-n} dr.$

495. $\int (a^2 - 2ax)^{-\frac{1}{2}} dx.$

497. $\int \frac{k dt}{\sqrt{-ct}}.$

499. $\int \sin \frac{x-c}{\sqrt{a}} dx.$

501. $\int \sqrt{a} \sin(\sqrt{a} t) dt.$

503. $\int \frac{2 \cos ax - \sin \beta x}{a + \beta} dx.$

505. $\int (a+t)^3 dt.$

507. $\int \left(\frac{1}{1+x} - 4\right)^3 dx.$

509. $\int t^2 \sqrt{a+b-at^3} dt.$

511. $\int \frac{x dx}{\sqrt{(a^2+x^2)^3}}.$

513. $\int x(a+bx^2)^n dx.$

515. $\int \frac{x^4 dx}{3a-4bx^5}.$

517. $\int \frac{\sin(\pi\sqrt{s}-\delta)}{\sqrt{s}} ds.$

518. $\int \log x \frac{dx}{x}$.

519. $\int x \tan \pi x^2 dx$.

520. $\int x e^{-\sqrt{x}} dx$.

521. $\int \log \sqrt{1-x} dx$.

522. $\int x \log \sqrt[3]{a^2 - x^2} dx$.

523. $\int x \left(\frac{a}{1+x^2} - b \right)^2 dx$.

524. $\int \frac{2x+p}{x^2+px+q} dx$.

525. $\int \frac{(b-x^2) dx}{(a+3bx-x^3)^2}$.

526. $\int ap \left[\frac{p^2}{c^2} - 1 \right]^{-\frac{3}{2}} dp$.

527. $\int \frac{2at dt}{5a-2b+4t^2}$.

528. $\int \frac{3 dx}{5-2x^2}$.

529. $\int \frac{3 dx}{5+2x^2}$.

530. $\int \frac{dx}{(x+a)^2 + (x-a)^2}$.

531. $\int \frac{dt}{1+7t^2}$.

532. $\int \frac{dp}{l-p^2}$.

533. $\int \frac{2 ds}{63+27s^2}$.

534. $\int \frac{dx}{(x+a)^2 - (x-a)^2}$.

535. $\int \frac{dq}{m^2+n^2q^2}$.

536. $\int \frac{\cos x dx}{\sin^2 x}$.

537. $\int \frac{\sin x dx}{\cos^5 x}$.

538. $\int \frac{du}{p+qu^2}$.

539. $\int \frac{dx}{b+(x-a)^2}$.

540. $\int \frac{dx}{b-(x-a)^2}$.

541. $\int \frac{(3+5x) dx}{\sqrt{2-6x-5x^2}}$.

542. $\int \frac{x dx}{1+x^4}$.

543. $\int \frac{y dy}{m-y^4}$.

544. $\int \frac{x^7 dx}{5+13x^{16}}$.

545. $\int \frac{x^4 dx}{1-x^2}$.

546. $\int \frac{x^{-1} dx}{\sqrt{\log x}}.$

547. $\int \tan(nx - 2) dx.$

548. $\int \frac{(c^2 - r^2)^3}{r} dr.$

549. $\int e^{-nx-x^2}(n+2x) dx.$

550. $\int \cos x \sqrt{1 - k^2 \sin^2 x} dx.$

551. $\int \frac{dx}{\cos^2 \frac{x}{l}}.$

552. $\int e^{-\sin \theta} \cos \theta d\theta.$

553. $\int \frac{\sin \theta d\theta}{\sqrt{4 - \cos \theta}}.$

554. $\int \sin \theta \log \cos \theta d\theta.$

555. $\int \cos \log x \frac{dx}{x}.$

556. $\int \frac{1 + \cos \theta}{1 - \cos \theta} d\theta.$

557. $\int \cos^2 \theta \sin \theta d\theta.$

558. $\int \sin x \cos^2 2x dx.$

559. $\int \cos x \sin 2x dx.$

560. $\int \sin^2 x \cos x dx.$

561. $\int \sin^2 x \cos^2 x dx.$

562. $\int \sin^n x \cos x dx.$

563. $\int \cos^n x \sin x dx.$

564. $\int \cos^2 mx dx.$

565. $\int \sin^2 mx dx.$

566. $\int \frac{dx}{a^2 \cos^2 x + b^2 \sin^2 x}.$

Ans. $\frac{1}{ab} \tan^{-1} \left(\frac{b \tan x}{a} \right).$

567. $\int \frac{\sin x \cos x dx}{a \cos^2 x + b \sin^2 x}.$

Ans. $\frac{1}{2(b-a)} \log(a \cos^2 x + b \sin^2 x).$

568. $\int \frac{\cos x dx}{\sqrt{1 - k^2 \sin^2 x}}.$

569. $\int \sin mx \sin nx dx.$

Ans. $\frac{\sin(m-n)x}{2(m-n)} - \frac{\sin(m+n)x}{2(m+n)}.$

$$570. \int \sin mx \cos nx \, dx. \quad \text{Ans.} \quad -\frac{\cos(m-n)x}{2(m-n)} - \frac{\cos(m+n)x}{2(m+n)}.$$

$$571. \int \cos mx \cos nx \, dx. \quad \text{Ans.} \quad \frac{\sin(m-n)x}{2(m-n)} + \frac{\sin(m+n)x}{2(m+n)}.$$

Evaluate the following integrals by the aid of the *Tables*.

$$572. \int \frac{dx}{3-7x+2x^2}.$$

$$573. \int \frac{dx}{3-2x+7x^2}.$$

$$574. \int \frac{dx}{3x-7x^2+2x^3}.$$

$$575. \int \frac{x \, dx}{3-2x+7x^2}.$$

$$576. \int \frac{dx}{(3-7x+2x^2)^2}.$$

$$577. \int \frac{dx}{3x^2-2x^3+7x^4}.$$

$$578. \int \frac{dx}{\sqrt{3-7x+2x^2}}.$$

$$579. \int \frac{dx}{\sqrt{3-2x+7x^2}}.$$

$$580. \int \frac{dx}{x\sqrt{3-7x+2x^2}}.$$

$$581. \int \frac{dx}{x\sqrt{3-2x+7x^2}}.$$

$$582. \int \frac{dx}{(3-7x+2x^2)^{\frac{3}{2}}}.$$

$$583. \int \frac{dx}{(3-2x+7x^2)^{\frac{5}{2}}}.$$

$$584. \int \frac{dx}{4-5\cos x}.$$

$$585. \int \frac{dx}{5-4\cos x}.$$

$$586. \int \frac{5 \, dx}{3+7 \tan x}.$$

$$587. \int \frac{dx}{11+13 \sin x}.$$

$$588. \int \frac{dx}{(5-4\cos x)^2}.$$

$$589. \int \frac{dx}{\cos x(5-4\cos x)}.$$

$$590. \int \frac{dx}{\sin x(5-4\cos x)}.$$

$$591. \int \frac{dx}{9-7\cos^2 x}.$$

$$592. \int \frac{dx}{10-\cos x+2\sin x}.$$

$$593. \int \frac{x \, dx}{1+\cos x}.$$

G. — DEFINITE INTEGRALS

594. The hyperbola $xy = 100$ rotates about the axis of x . Find the volume of that part of the solid thus generated which is contained between the planes perpendicular to the axis and corresponding to $x = 5$ and $x = 2$.

595. The curve $y = \sec x$ revolves about the axis of x . Find the volume of the solid whose bases correspond to $x = \frac{1}{6}\pi$ and $x = \frac{1}{8}\pi$.

596. The curve $y = x - x^4$ rotates about the axis of x . Find the volume of the solid generated by that part of it which lies above the axis of x .

597. The hyperbola $\frac{x^2}{a^2} - \frac{y^2}{b^2} = 1$

revolves about the axis of x . Find the volume cut off from one of the two solids thus obtained by a plane perpendicular to the axis and distant h from the vertex.

$$\text{Ans. } \frac{\pi b^2 h^2}{3a^2} (3a + h).$$

598. So much of that arc of the curve $y = \cos x - \frac{1}{2} \cos 2x$ which cuts the axis of ordinates and lies above the axis of x rotates about the latter axis. Find the volume of the solid generated.

599. The curve $y = \cos^{-1}x$ rotates about the axis of x . Find the volume generated by that part of the curve for which $0 \leq y \leq \pi$, the base being a plane perpendicular to the axis at $x = -1$.

600. The parabola $x^{\frac{1}{2}} + y^{\frac{1}{2}} = a^{\frac{1}{2}}$ rotates about the axis of x . Find the volume of the solid bounded by the arc which is tangent to the coordinate axes at its extremities, the base being formed by a plane through the origin perpendicular to the axis.

601. Determine the volume of the following solid. Think of the axis of y as vertical and consider the cylinder whose

elements are perpendicular to the curve $y = 12 - 12x^2$. Next, turn this cylinder about the axis of y through 90° . The two cylinders and a horizontal plane through the origin bound the solid in question.

602. If the base of the conoid of Ex. 5, p. 161, is an ellipse whose plane is parallel to the fixed line, show that the volume is $\frac{1}{2}\pi abh$, where h denotes the distance from the line to the plane.

603. The solid of p. 159, Fig. 49, is cut by a plane through O , perpendicular to the plane of the base AOB and making an angle of 45° with OA . Determine the volume of the part with the vertex A .

604. A horn is generated by a variable circle whose plane turns about a fixed line. The point of the circle nearest the line describes a quadrant AB of a circle of radius a , and the radius of the variable circle is $c\theta$, where θ denotes the angle between the variable plane and its initial position, when it passes through A . Show that the volume of the horn is $\frac{1}{192}\pi^4 c^2(8a + 3\pi c)$.

605. Find the area of the lateral surface of the solid described in Ex. 603.

606. Find the area of the lateral surface of the solid described in Ex. 601. *Ans.* 64, nearly.

607. An arbitrary closed curve is drawn on the surface of a sphere, cutting out a region S from that surface. Show that the volume of the cone whose vertex is at the centre of the sphere and whose base is S is

$$\frac{1}{3}AR,$$

where A denotes the area of S and R the radius of the sphere.

608. The curve $r = f(\theta)$ rotates about the axis $\theta = 0$. Assuming $f(\theta)$ to be single-valued and continuous for $\alpha \leq \theta \leq \beta$, where $0 \leq \alpha < \beta \leq \pi$, obtain a formula for the volume of the solid generated by the rotation of the plane region bounded by the curve and the two radii vectores drawn to its extremities.

609. Hence determine the volume of the solid generated by the rotation

- (a) of the curve $r = a \cos 2\theta$;
 (b) of the lemniscate $r^2 = a^2 \cos 2\theta$;
 (c) of the curve $r = 1 - \theta^2$.

610. Show that, if two solids are so related to each other that, when cut by any plane parallel to a certain fixed plane, the areas of the two cross-sections are equal, then the volumes of the solids are equal. (*Cavalieri's Theorem.*)

611. Find the areas of the surfaces in (a) Ex. 594; (b) Ex. 597.

612. Find the fluid pressure on the vertical plane area bounded by the curve

$$y^2 = \frac{a^4 b}{a^4 + x^4}$$

and the double ordinate $x = h$, the axis of y lying in the surface of the liquid.

613. Assuming that the density of water at a distance of x ft. below the surface is

$$\rho = \rho_0(1 + .000\,001\,3x),$$

find how much greater the pressure is on a vertical rectangle 10 ft. broad and a mile deep, with one side in the surface, than what it would be if water were incompressible.

614. Find the pressure on the end of the trough described in Ex. 2, p. 164, if the density is a linear function of the distance below the surface.

615. If the density, ρ of any curve is variable, show that the mass of the curve is

$$M = \int_0^l \rho ds.$$

616. The density of a rod is proportional to the distance from one end. Find its mass.

617. The density of a semicircular wire is proportional to the perpendicular distance from the diameter joining its ends. Find its mass.

618. If in the preceding problem the density is proportional to the square of the perpendicular distance from the radius drawn perpendicular to the above diameter, what is the mass?

619. Find the centre of gravity of the rod in Ex. 616.

620. Find the centre of gravity of a quadrant of the wire in Ex. 617 and in Ex. 618.

621. The density of a spherical surface at any point is proportional to the distance of the point from a fixed diameter. Required the mass.

622. The same problem for a cone of revolution, the density being proportional to the distance from the axis.

623. The density at each point of a sphere is proportional to the distance of the point from the centre. Find its mass.

624. If the density is $a + br$, where r denotes the distance from the centre, required the mass.

Determine the following moments of inertia and radii of gyration:

625. A rod whose density is proportional to the distance from one end, about a perpendicular at that end.

626. The same rod, about a perpendicular bisector.

627. The circular wire of Ex. 617 about the diameter.

628. The same, about the radius perpendicular to the diameter.

629. The circular wire of Ex. 618 about the diameter.

630. The same, about the radius perpendicular to the diameter.

631. A circular disk whose density is proportional to the distance from the centre, about the centre.

632. The same, about a diameter.
633. A circular disk whose density is proportional to the distance from the circumference, about the centre.
634. The same, about a diameter.
635. A circular disk whose density at any point is $\lambda\sqrt{b^2-r^2}$, r denoting the distance from the centre, about the centre.
636. The same, about a diameter.
637. A conical surface of revolution, about the axis of the cone.
638. A spherical surface, about a diameter.
639. A conical surface of revolution whose density is proportional to the distance from the axis, about the axis.
640. A spherical surface whose density is proportional to the distance from a diameter, about that diameter.
641. A sphere whose density is proportional to the distance from the centre, about a diameter.
642. A sphere whose density is proportional to the distance from a diameter, about that diameter.
643. A sphere whose density is any linear function of the distance from the centre, about a diameter.
644. A triangle whose density is proportional to the distance from one side, about that side.
645. A semicircle whose density is proportional to the distance from the bounding diameter, about that diameter.

Determine the following centres of gravity:

646. A uniform circular segment.
647. A uniform circular sector. Check your answer.
648. A segment of the equilateral hyperbola

$$x^2 - y^2 = a^2,$$

cut off by the double ordinate $x = a + h$.

649. The corresponding segment for any hyperbola.

650. A triangle whose density is proportional to the distance from one side.

651. A uniform parabolic wire, extending equal distances to each side of the vertex.

652. A semicircular wire whose density is proportional to the length of the arc measured from its middle point.

653. The same, when the density is proportional to the distance from the diameter through its extremities.

654. A semicircle whose density is proportional to the distance from the bounding diameter.

655. A semicircle whose density is proportional to the distance from the centre. (Suggestion. First obtain a formula for the centre of gravity of a semicircle whose density is an arbitrary function of the distance from the centre.)

656. Show that the ordinate of the centre of gravity of the uniform plane area of § 1, p. 153, is given by the formula: *

$$\bar{y} = \frac{\int_a^b y^2 dx}{2A}.$$

657. Find the attraction of a quadrant of a circle on a particle at the centre of the circle.

658. Find the attraction of so much of a cylindrical surface of revolution as lies between two planes normal to the axis, on a particle situated in the axis.

659. The same, when the density of the surface is proportional to the distance from one of the planes.

660. Find the attraction of a homogeneous hemispherical surface on a particle situated at the centre of the sphere.

* This formula was given to me by Mr. Rogers Sherman Hoar, at that time a student in the first course in the Calculus.

661. The same question, only that the density of the surface is proportional to the distance from the axis.

662. The same, when the density is proportional to the distance from the base measured along the arc of a great circle meeting the base at right angles.

663. Find the attraction of the semicircular wire (a) in Ex. 617; (b) in Ex. 618, on a particle at the centre of the circle.

664. The same for a particle on the circumference extended, at the point situated symmetrically with respect to the wire.

665. Find the attraction of a homogeneous surface in the form of a right cone of revolution on a particle at the centre of the base.

666. Find the attraction of the surface of a frustum of a cone of revolution on a particle at the centre of the smaller base.

667. Evaluate the double integral

$$\iint_s xy dS,$$

where S is the rectangle whose vertices lie at the points (1, 2), (1, 5), (3, 2), (3, 5). *Ans.* 42.

668. The same integral, extended over the triangle cut off from the first quadrant by the line joining the points (0, 3) and (3, 0). *Ans.* $3\frac{3}{8}$.

669. Compute
$$\iint_s (40 + x + y^2) dS,$$

the region S being the piece of the plane bounded by the parabola $y = x^2 - x$ and the right line $y = x$. *Ans.* $55\frac{1}{2}$.

670. Extend the integral

$$\iint_s \left(40 - \frac{x^2}{2} - \frac{y^2}{3}\right) dS$$

over the same region, and check your answer by inverting the order of integration.

671. Compute the value of

$$\int_S \int x^2 y dS,$$

the region S consisting of a triangle whose vertices are at the origin and the points $(1, 2)$ and $(2, 1)$.

672. Check your result in the last question by using polar coordinates skilfully.

673. Find the centre of gravity of the solid consisting of the part cut out of a homogeneous sphere by two planes through the centre.

674. Show that the moment of inertia of a homogeneous right cylinder about an axis through its centre perpendicular to its axis of figure is

$$I = M \left(\frac{r^2}{4} + \frac{l^2}{12} \right).$$

675. Find the moment of inertia of a homogeneous right cone of revolution about an axis through the vertex perpendicular to the axis of figure.

INDEX

- Absolute value, 5.
 Acceleration, 190.
 Addition theorem, 75.
 Amsler's planimeter, 409.
 Approximate computations, Chap. XX.
 Area under a curve, 111, 117, 153, 407;
 — in polar coordinates, 132;
 — of a surface of revolution, 167;
 — of any surface, 367;
 — of cylindrical surface, 370;
 further problems in areas, 453.
 Attraction of gravitation, 181, 457.
 Cardioid, 152.
 Catenary, 131, 400.
 Caustics, 350.
 Centre of fluid pressure, 175.
 Centre of gravity, 169;
 general formulation for —, 174, 381;
 further problems in —, 456.
 Change of variable, 295.
 Chart, A Mercator's, 331.
 Compound interest law, 82.
 Computation, Numerical, Chap. XX.
 Concave upward, Test for, 50;
 further examples for —, 438.
 Confocal quadrics, 326.
 Conservative field of force, 395.
 Contact of curves, 276.
 Continuity, 4, 20, 283.
 Convergence, Fundamental principle
 for, 246.
 Cubic equation, 58, 61.
 Curvature, Definition of, 134;
 radius of —, 136;
 formula for — in polar coordinates,
 145.
 Curve tracing, 51;
 further problems in —, 110, 439.
 Curves on the sphere, cylinder, and
 cone, 329;
 — without tangents, 422.
 Cycloid, 146.
 Definite integral, 156, 358, 380;
 further problems relating to —, 452.
 Density, Examples of variable, 183,
 188, 360, 376, 381, 396, 454.
 Derivative, 9;
 logarithmic —, 22;
 partial —, 287;
 directional —, 308;
 normal —, 309.
 Developments in series, Chap. XIII.
 Differentials, Definition of, 91;
 — of higher order, 94;
 — of arc, 99;
 — of functions of several variables,
 293;
 total —, 293;
 exact —, 309.
 Differentiation, General formulas of,
 13, 21, 94;
 special formulas of —, 95;
 — of implicit functions, 34, 302.
 Direction cosines, 283, 289, 319.
 Directional derivatives, 308.
 Double integral, 358, 458.
 Duhamel's theorem, 164.
 Elementary functions, 96.
 Envelopes, 344.
 Epicycloid, 149.
 Equiangular spiral, 91, 130.
 Errors of observation, etc., 306, 440.
 Euler's theorem for homogeneous
 functions, 300.
 Evolute, 139, 349.
 Exact differentials, 309.

- Fluid pressure, 161.
 Four-cusped hypocycloid, 150.
 Fractional exponents, 27.
 Function, Definition of a , 2;
 continuous —, 4, 20, 58;
 implicit —, 34, 302;
 algebraic —, 35;
 test for increasing or decreasing
 —, 49;
 further examples of latter, 281, 437;
 inverse —, 68;
 elementary —, 96;
 — of several variables, 282;
 hyperbolic —, 412;
 exponential —, 417;
 — without a derivative, 422.
- Gudermannian, 416.
 Guldin, *cf.* Pappus.
- Helix, 318.
 Homogeneous functions, 300.
 Hyperbolic functions, 412.
 Hypocycloid, 150.
- Implicit functions, 34, 302.
 Indefinite integral, 156.
 Indeterminate forms, 231, 278, 280.
 Indicator diagrams, Area of, 409.
 Infinitesimals, 85;
 — with several variables, 293.
 Infinity, 19.
 Inflection, Point of, 51, 53, 276.
 Integral, Definition of (indefinite),
 114;
 tables of —, 126;
 — as the limit of a sum, 155, 358, 380;
 definite —, 156, 358, 380;
 iterated —, 354, 382;
 double —, 358;
 surface —, 374;
 triple —, 380;
 line —, 390;
 numerical computation of definite
 —, 406;
 further problems in double and
 triple —, 458.
 Integration, Special formulas of, 118;
 further problems in —, 446;
 variable limits of —, 186;
 mechanical —, 409.
 Iterated integral, 354, 382.
- Jacobian determinant, 305.
- Law of the mean, 230, 334;
 generalized —, 234.
 Laws of motion, 190.
 Lemniscate, 133.
 Length of a curve, 129, 166.
 Limits, Three theorems about, 15;
 the — %, etc., 231, 278, 280;
 — for functions of several variables,
 282.
 Line integrals, 390.
 Logarithmic spiral, *cf.* *Equiangular
 spiral*.
 Loxodrome, 330.
- Mass in terms of density, 360, 381.
 Maxima and minima, 39, 53, 275, 336;
 further problems in —, 104, 279, 435.
 Mercator's chart, 331.
 Minima, *cf.* *Maxima*.
 Moment of inertia, 176, 359, 381;
 further problems in —, 455.
- Napierian logarithm, Reason for, 82.
 Natural logarithm, *cf.* *Napierian* —.
 Newton's laws of motion, 190;
 — method for numerical equations,
 399.
 Normal, Equation of, 37;
 — lines and planes, 286, 289, 316, 317;
 — derivative, 309;
 principal —, 325.
 Numerical computation, Chap. XX.
- Osculating circle, 138, 277;
 — plane, 323.
- Pappus, Theorems of, 362.
 Peirce's Tables, 126.
 Planimeter, Amsler's, 409.
 Principal normal, 325.
- Quadratic forms, 340.
 Quadric surfaces, Confocal, 326.
- Radian measure, Reason for, 66.
 Radius of gyration, 178.
 Rates, *cf.* *Velocity*.
 Rhumb line, 330.
 Rolle's theorem, 229.

- Roots of equations, 57, 398;
 further problems in —, 110, 281, 322.
 Roulettes, 150.
- Semi-cubical parabola, 141.
- Series, Definition of infinite, 244;
 power —, 257;
 Maclaurin's —, 262;
 Taylor's —, 264, 266, 335;
 binomial —, 272.
- Simple harmonic motion, 201.
- Simpson's rule, 406.
- Slope of a curve, 5.
- Spirals, 131;
 — of Archimedes, 145;
 cf. also *Equiangular spiral*.
- Square root sign, 4.
- Successive approximations, 403.
- Surface integral, 374.
- Tables of integrals, 126.
- Tangent, Slope of, 5, 11;
- Tangent, Equation of, 37;
 — in polar coordinates, 90;
 — plane, 289, 316;
 — line to space curve, 317.
- Taylor's series, 264;
 — theorem, 266, 335.
- Test-ratio, 250.
- Total differential, 292.
- Triple integral, 380, 459.
- Trisectrix, 145.
- Trochoids, 151.
- Velocity, Definition of, 46;
 rates and —, 101;
 further problems in —, 108, 109, 439.
- Volume of a solid of revolution, 157;
 volumes of other solids, 159, 352;
 further problems relating to such
 volumes, 452.
- Work done by a variable force, 393,
 409.

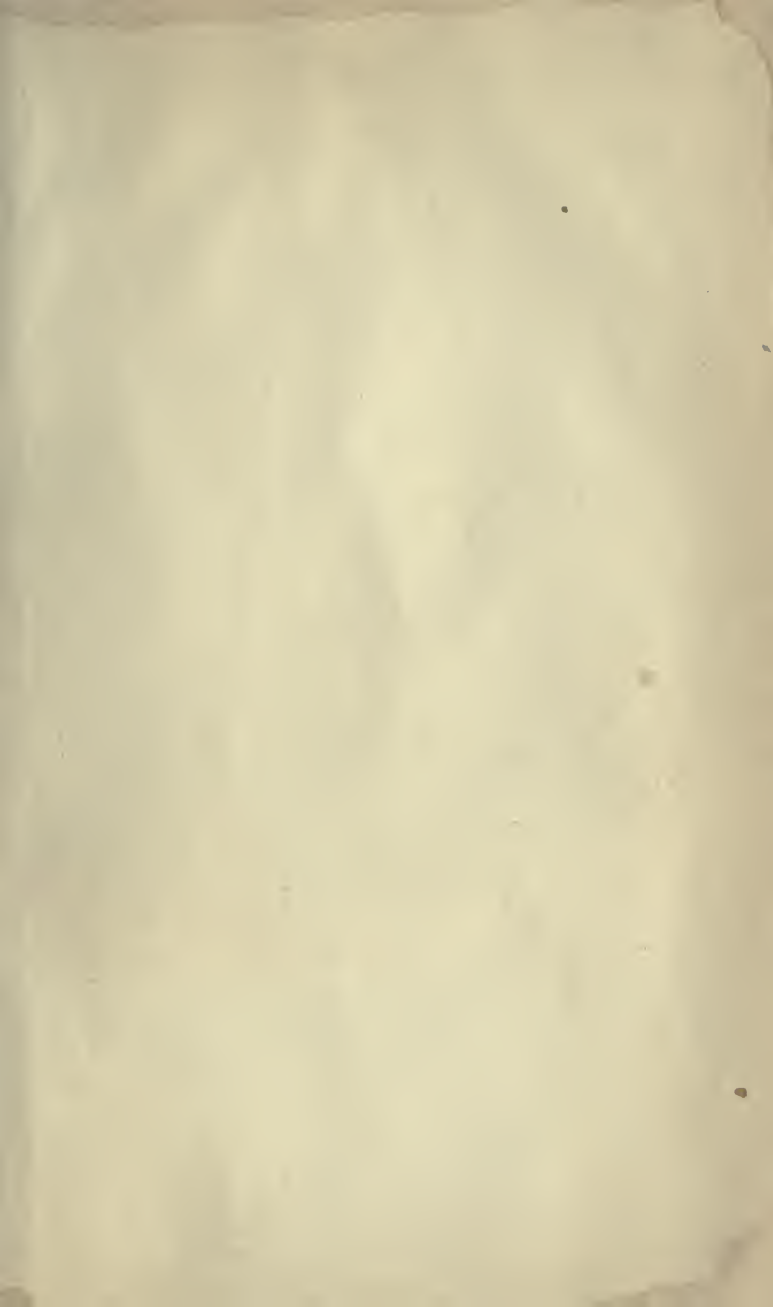

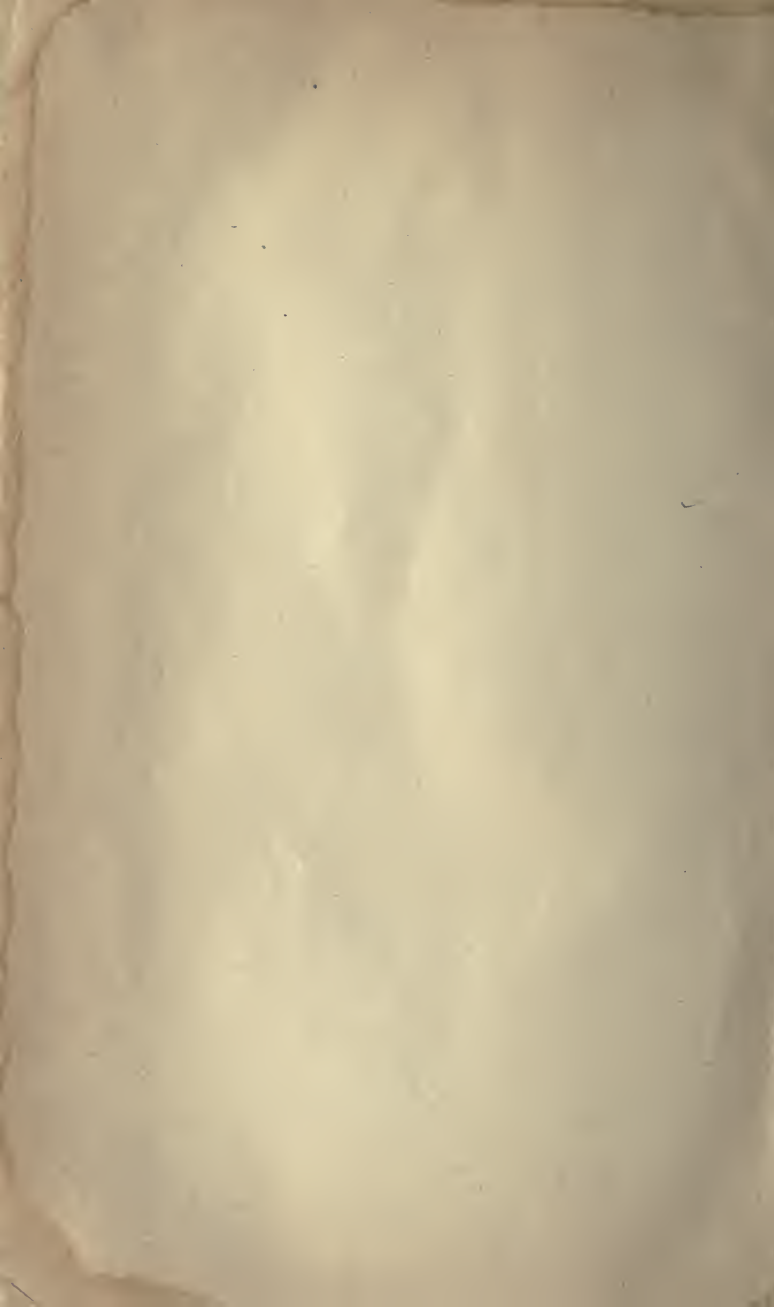

14 DAY USE
 RETURN TO DESK FROM WHICH BORROWED
LOAN DEPT.

This book is due on the last date stamped below, or
 on the date to which renewed.

Renewed books are subject to immediate recall.

25 Feb '57 TS	3 Fe '59 ES
REC'D LD	REC'D LD
FEB 11 1957	JAN 8 5 1959
30 Dec '57 W	13 Dec 61 LZ
REC'D LD	REC'D LD
FEB 8 1958	DEC 15 1961
10 Apr '58 CS	24 Apr '57 DF
REC'D LD	REC'D LD
REC 16	MAY 25 1962
APR 8 1958	AUG 23 1972 9 1
REC'D CIRC DEPT	FEB 9 '74

LD 21-100m-6, '56
 (B9311s10)476

General Library
 University of California
 Berkeley

383514

UNIVERSITY OF CALIFORNIA LIBRARY

