

EX LIBRIS

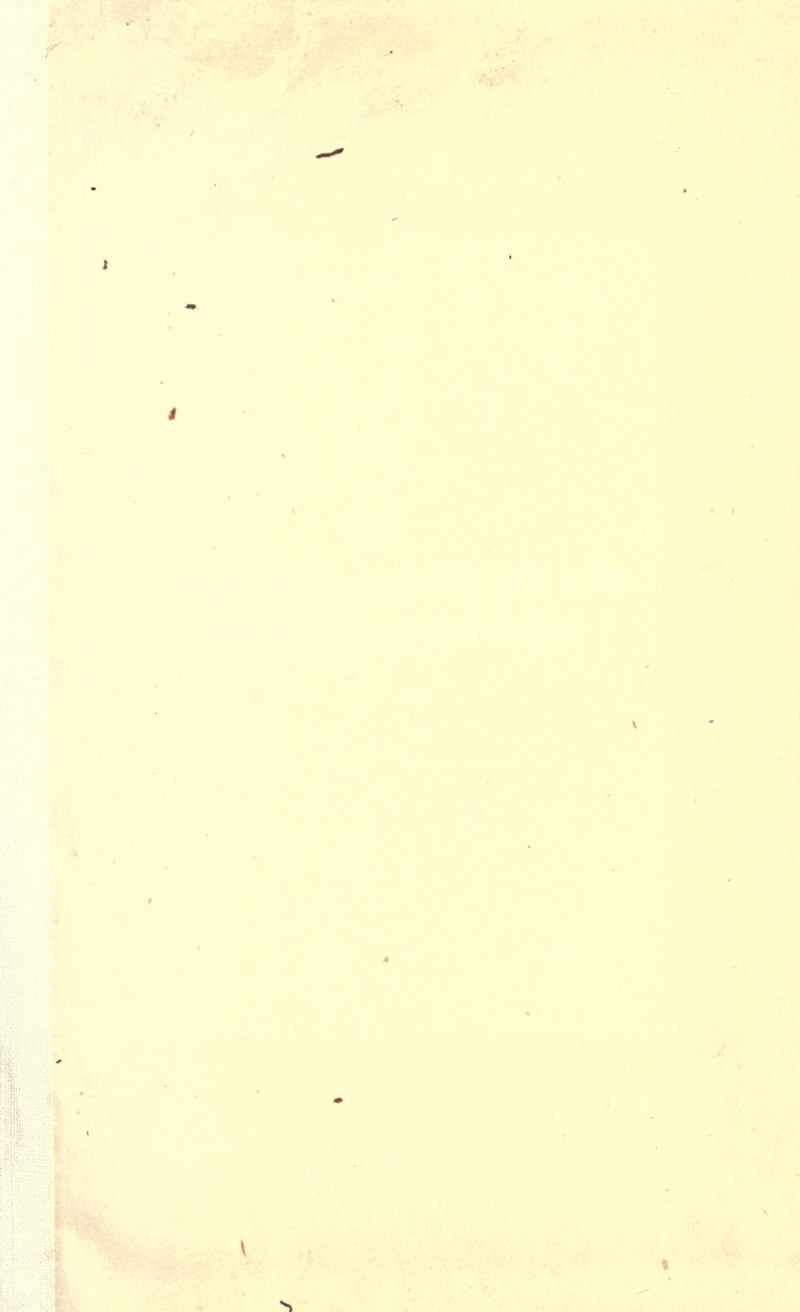



PRACTICAL SURVEYING AND  
ELEMENTARY GEODESY



MACMILLAN AND CO., LIMITED  
LONDON • BOMBAY • CALCUTTA  
MELBOURNE

THE MACMILLAN COMPANY  
NEW YORK • BOSTON • CHICAGO  
DALLAS • SAN FRANCISCO

THE MACMILLAN CO. OF CANADA, LTD.  
TORONTO

# PRACTICAL SURVEYING AND ELEMENTARY GEODESY

INCLUDING

LAND SURVEYING, LEVELLING, CONTOURING, COMPASS  
TRAVERSING, THEODOLITE WORK, TOWN SURVEYING,  
ENGINEERING FIELD WORK AND SETTING OUT  
RAILWAY CURVES

*WITH NOTES ON PLANE TABLING, ASTRONOMICAL SURVEYING  
AND HELIOGRAPHING*

BY

HENRY ADAMS

LATE PROFESSOR OF ENGINEERING AT THE CITY OF LONDON COLLEGE  
M.INST.C.E., M.I.MECH.E., F.S.I., F.S.E., F.R.SAN.I., M.S.A., ETC.  
EXAMINER TO THE INSTITUTION OF MUNICIPAL ENGINEERS, THE SOCIETY OF  
ENGINEERS, THE INSTITUTE OF SANITARY ENGINEERS, THE ROYAL  
SANITARY INSTITUTE AND THE SOCIETY OF ARCHITECTS

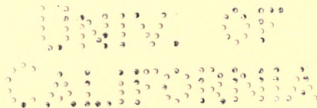

MACMILLAN AND CO., LIMITED  
ST. MARTIN'S STREET, LONDON

1913

TA545

A2

*COPYRIGHT*

70 .vml  
ANBOLIAO



## PREFACE.

AN endeavour has been made in this manual to present the elements of practical land surveying in a form suitable for students preparing for examinations in that subject held by various educational and professional bodies, and also for private workers. It is hoped and believed that the volume will be a helpful guide to practical methods whether the intention of the student is to undertake responsible work in the field, or more particularly to qualify for an examination.

Many years' experience as a practical surveyor and teacher of land surveying in all its branches has made the author acquainted with the difficulties experienced by beginners; and although personal effort is necessary to master any subject, progress is facilitated when principles and procedure are stated precisely and concisely. This has been the aim in the preparation of the present book. The course of work is so graduated that the careful study of each chapter, together with practical field work and the plotting of the accompanying surveys should enable the diligent student to become qualified to undertake land surveying in a few months.

The questions at the ends of the chapters will serve as exercises to test progress; while those at the end of the volume should be particularly useful to students preparing for public examination in land surveying.

HENRY ADAMS.

60 QUEEN VICTORIA ST., E.C.



# CONTENTS.

## CHAPTER I.

Scope of subject—Definition of land surveying—Geometry and mensuration—Origin of the term geometry—Distinction between theoretical or pure geometry, and practical or applied geometry—Principles upon which land surveying is dependent—Difference between old system of surveying and modern systems—Objects in view in measuring land—Distinction between office and field work—Six selected problems in practical geometry—Table of linear measures—Table of square measures. . . . . 1

## CHAPTER II.

Linear measurement—British standard of length—Units of measurement—Units adopted in measuring land—Form of working in calculating area—Pointing off—Rule for area of rectangular figure—Example—Rule for area of triangular figure when base and perpendicular are given—Example—Rule for area of triangular figure when sides only are given—Example—Rule for area of four-sided figure, having two sides parallel—Example—Irregular four-sided figure divided into two triangles by a diagonal—The same divided into two triangles and a trapezoid—Example—Method of tabulating the working. 7

## CHAPTER III.

Drawing to scale or plotting—Description and use of chain scales—Decimal system—Base line of survey—Direction—Points of the compass—Direction of north obtained by a watch—Magnetic meridian—Magnetic variation—North point. . . . . 13

## CHAPTER IV.

Measuring straight-lined figures—Tie and check lines—Rule for distance from angle—Well-conditioned and ill-conditioned triangles—

Use of box tape—Measurements put on sketch plan instead of in field-book—Testing tape for shrinkage—Gunter's chain—General description of its use—Tally points—Entries in field-book—Steel tapes. . . . . 20

## CHAPTER V.

Measurement of straight-sided fields—Use of station poles—How chain lines and stations are indicated in field-book—Conventional signs—Offsets, how measured and recorded—Examples of offset pieces—Plotting from field notes—Drawing in the outlines. . . . . 26

## CHAPTER VI.

Nature of boundaries—Hedge and ditch—Why hedge is on inside of ditch—Allowance for width of ditch—Owner's side of boundary, how marked—Poling out chain line when view of ends obstructed by rising ground—Numbering and naming stations. . . . . 33

## CHAPTER VII.

Hedges and trees on plans—Area of field by equalising lines—Area by computing scale—Area by planimeter—Simpson's rule for area—Plotting a survey plan with junctions in boundaries. . . . . 41

## CHAPTER VIII.

Cutting-up a plan, or arranging chain-lines, for a survey—Complete survey of small field to explain routine—Office plans and finished plans—Estate in detached portions, how plotted—Colouring plans. . . . . 48

## CHAPTER IX.

Surveying woods, lakes, marshes, standing crops, etc.—Example of survey of a wood and a lake—Measuring past obstructions—Cross staff, construction and use—Optical square, construction and use—Setting up perpendiculars by chain only. . . . . 55

## CHAPTER X.

Measuring gaps and detours, view unobstructed—Special precautions when view is obstructed—Measuring across a lake, quarry or bend in river—Measuring across a stream, river or valley—Example of survey at Hilly Fields. . . . . 63

# CONTENTS

ix

## CHAPTER XI.

Plans and maps—Various systems of projection—Curvature of earth not taken into account in ordinary surveys—Ordnance survey maps—Surveying over hilly ground—Correction for inclination, how made—Instruments for obtaining angle of slope—Indicating hilly ground on maps—Hachures—Contour lines. . . . . 71

## CHAPTER XII.

Field notes for survey of small farm—Sketch of chain lines—Secondary lines not falling on previous station—Plotting notes and preparation of survey plan. . . . . 82

## CHAPTER XIII.

Instructions of “The Copyhold, Inclosure and Tithe Commission” for the preparation of “First Class Plans”—Regulations for testing plans—Charges for surveys—Errors in chaining. . . . . 90

## CHAPTER XIV.

Traversing with chain—Traversing with prismatic compass—Reducing bearings—Circumferentor—Definition of terms used in traversing. . . . . 96

## CHAPTER XV.

Examples of open and closed traverses—Reducing to a single meridian—Tables of sines and cosines—Traverse tables—Plotting traverse surveys. . . . . 105

## CHAPTER XVI.

Copying plans by tracing and photography—Use of triangular compass—Pricking through and transfer—Enlarging and reducing by proportional squares—Use of proportional compasses—Use and adjustment of pantagraph and eidograph—Ordnance maps. . . . . 111

## CHAPTER XVII.

Definition of levelling—Datum line—Gravatt’s dumpy level—Construction of level—Construction of level staff—Curvature and refraction. . . . . 118

## CHAPTER XVIII.

Simple and compound levelling—Parallax and collimation, and adjustments therefor—Bubble error and its adjustment—Setting up a level—Holding the staff. . . . . 126

## CHAPTER XIX.

Levelling a section—Running or flying levels—Check levels—Bench marks—Ordnance datum—Reducing levels—Plotting sections—Minus readings. . . . . 133

## CHAPTER XX.

Notes for part of a main section—Plotting of same—Working section of short piece of railway—Description of features shown—Rise and fall method of keeping level book contrasted with collimation method—Telemetry, or optical measurement of distances. . . 141

## CHAPTER XXI.

Levels of building plots—Equal vertical and horizontal scales—Spot levels—Building plot with sections—Building plot with sections and contour lines—Levelling with barometer—Surveyor's compensated aneroid barometer and method of using. . . . . 148

## CHAPTER XXII.

Principles of angular measurement—Old definition of an angle—Trigonometrical definition—Instruments for setting off or measuring angles—Semicircular and rectangular protractors—Circular protractor with pricker arm and vernier—Scale of chords. . . . . 156

## CHAPTER XXIII.

Construction and reading of diagonal scale—Construction and reading of vernier scale—Construction and reading of verniers on the theodolite—Construction and adjustment of box sextant—Method of using same—Construction and use of plane-table—The three-point problem. . . . . 162

## CHAPTER XXIV.

Construction of theodolite—Primary horizontal circle and verniers—Vertical circle and verniers—Setting up and adjusting theodolite—Reading verniers—Repeating an angle. . . . . 170

## CHAPTER XXV.

Traversing with theodolite, surveying by the back angle—Field notes of traverse survey—Traversing by angles from magnetic meridian—Triangulation or surveying from two stations—Field notes of

# CONTENTS

xi

survey from two stations—Observations required for obtaining heights and distances. . . . . 176

## CHAPTER XXVI.

Principles of town surveying—Choice of base lines—Chain or steel tape—Triangulated offsets—Sketching details—Field notes of lines and angles with offsets omitted—Plotting of same—Field notes of one street with measurements—Plotting of same—Connecting chain lines. . . . . 184

## CHAPTER XXVII.

Difference in lay-out of old and modern towns—Available accuracy depending upon scale employed—Double chain lines—Example of field-book—Plotting of same—Tape surveys—Sketch of back premises with measurements—Plotting of same. . . . . 192

## CHAPTER XXVIII.

Principal features of railway surveying—Limits of deviation—Reference book—Railway gauges—Engineering field work—Location field-book—Permanent stakes—Level pegs—Earthwork terms—Batters and slopes—Earthwork formulæ. . . . . 201

## CHAPTER XXIX.

Railway curves—Nomenclature of curves—Minimum radius—Curve “elements” and formulæ—Simple and compound curves—Reverse curves. . . . . 207

## CHAPTER XXX.

Difference in length of inner and outer rails—Centrifugal force and super-elevation of outer rail—Widening of gauge on curves—Transition curves. . . . . 220

## CHAPTER XXXI.

Ranging a curve—By chain and offsets—By one theodolite—By two theodolites—Practical example—Points and crossings—Sidings. . . . . 227

## CHAPTER XXXII.

Astronomical surveying—Finding true meridian—Celestial sphere—Longitude and local mean time—Astronomical, civil and nautical time—Finding the latitude of a place. . . . . 235

## CHAPTER XXXIII.

Signalling at a distance—The Morse alphabet and Universal code—Flag signalling—Flashing signals—Heliographing. . . . .	242
--	-----

## APPENDIX.

300 Examination questions. . . . .	245
------------------------------------	-----

INDEX. . . . .	272
----------------	-----



## CHAPTER I.

Scope of subject—Definition of land surveying—Geometry and mensuration—Origin of the term Geometry—Distinction between theoretical or pure geometry and practical or applied geometry—Principles upon which land surveying is dependent—Difference between old system of surveying and modern systems—Objects in view in measuring land—Distinction between office and field work—Six selected problems in practical geometry—Table of linear measures—Table of square measures.

**Scope of the subject.**—Geodesy comprises several branches of work that will perhaps be better recognised under their ordinary titles of chain surveying, levelling, theodolite work, compass traversing, town surveying, engineering field work, etc. It is proposed to deal with these in the order named.

**Land surveying**, as it is usually called, consists of accurately measuring and recording the lengths and positions of carefully selected lines, indicated by temporary poles placed in the ground adjacent to the boundaries of the various properties. Land is measured usually for one or both of two purposes, either to find the area or to enable a plan or map of the place to be prepared; in either case equal care must be taken in the measurements to produce correct results.

Many text-books commence with a chapter on **Practical Geometry**, and rightly so, because this forms the ground-work of the method of recording upon paper the plans of any surveys of which the measurements may have been obtained, while **Mensuration** is the art of determining the areas of the various plots or surveys by calculation, the two branches forming together that part of surveying which may be called office work, as distinguished from outdoor or field work.

**Geometry.**—The word Geometry is derived from two Greek words, signifying earth-measure or land-measure, and from this it may readily be assumed that Geometry had its origin in

attempts to measure exactly certain portions of the earth's surface. The science of Geometry is supposed to have had its birthplace in Egypt some 3000 years ago, and to have been necessitated by the annual overflow of the Nile obscuring any minor landmarks which might have been set up by the respective owners of property adjacent to its course. The theoretical investigations of Geometry have, however, far outstripped the direct practical use of the science.

Theoretical or Pure Geometry, of which Euclid, who lived in the third century before the Christian era, is the well-known exponent, teaches us, *by reasoning*, what are the properties of lines, surfaces, and solids, irrespective of matter or substance. Practical or Applied Geometry shows us in what way the properties may be made subservient to our various handicrafts.

Before use can be made of any of these properties, it is essential to know (1) the meaning of the different names or terms employed, (2) their fundamental relationships, and (3) what may be possible in the way of employing them. These are the (1) definitions, (2) axioms, (3) postulates given by Euclid.

A **definition** is simply a strict description of what is meant by a certain name.

An **axiom** is something intuitively known to be true or self-evident, and is so simple that it cannot be proved by anything simpler.

A **postulate** is something which it is admittedly possible to do.

Six simple and useful constructions in Practical Geometry are given below.

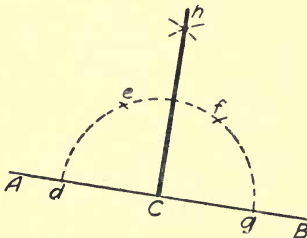

FIG. 1.—To erect a perpendicular from a given point in a straight line.

*From a given point in a straight line to erect a perpendicular.*

Let AB be the given line in any direction, and C the given point. Then from C, with any radius Cd, describe the arc defg, and from points d and g, with the same radius, cut the arc at e and f. From points e and f describe arcs intersecting in h, and join hC, which will be perpendicular to AB.

It will be observed that the given lines are shown thin, the construction lines dotted, and the lines found by construction thick. They are also lettered in the order of construction, the given parts with capital letters and the construction lines with small letters, so that what may be called the "life-history" of the problem is presented at a glance, and does not really require any description to enable anyone to work it out.

*To let fall a perpendicular from a given point on to a given straight line.*

Let  $AB$  be the given line and  $C$  the given point. From  $C$ , with any radius greater than the distance from the line, draw arcs cutting the line at  $d$  and  $e$ . From points  $d$  and  $e$ , with a radius less than the distance to  $C$ , describe arcs intersecting at  $f$ , and draw line from  $C$  through  $f$  to meet the base line in  $g$ . Then  $Cg$  will be the required perpendicular to  $AB$ .

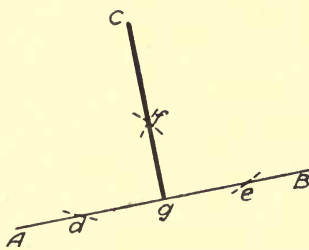

FIG. 2.—To let fall a perpendicular from a given point on to a given straight line.

*To copy a given angle.*

Let  $ABC$  be the given angle.

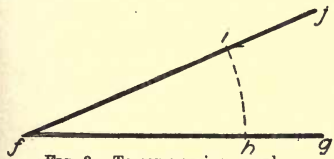
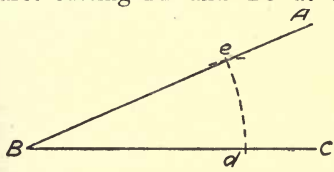

FIG. 3.—To copy a given angle.

With any radius  $Bd$  describe arcs cutting  $BA$  and  $BC$  at  $d$  and  $e$ . Then draw line  $fg$  indefinitely, or the same length as  $BC$ , and from  $f$  strike the arc  $ih$  with radius equal to  $Bd$ , then from point  $h$  with radius  $de$  cut  $hi$  in point  $i$ , and through  $i$  draw  $fg$  equal in length to  $BA$ . If  $BC$  is at any given angle with the horizontal, this angle may be first copied to give an identical position for the lines forming the angle.

To construct a triangle whose sides shall be equal to three given straight lines.

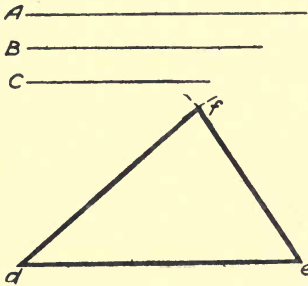

FIG. 4.—To construct a triangle having sides equal to three given straight lines.

Let A, B and C be the three given lines any two of which must be greater than the third. Draw  $de$  equal to A, from point  $d$  with radius equal to B describe an arc, and from point  $e$  with radius equal to C describe another arc to intersect the previous one in point  $f$ ; join  $fd$  and  $fe$ , then  $dfe$  is the required triangle.

To construct a triangle on a given line having the position and length of its perpendicular given.

Let AB be the given line (Fig. 5), C the position of the perpendicular and CD the length of perpendicular. Draw line AB and mark position C, then from C with any radius cut AB with arcs  $e$  and  $f$ , and from points  $e$  and  $f$  with any radius draw arcs intersecting in  $g$ . Then from point C through  $g$  draw CD equal to the given length CD, and join AD and BD.

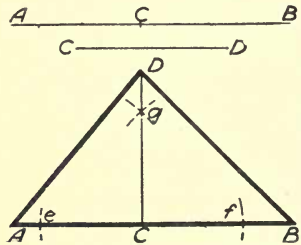

FIG. 5.—To construct a triangle on a given line having the position and length of its perpendicular given.

To make a triangle equal to a given trapezium.

Let ABCD be the given trapezium (Fig. 6). Join CA. Produce DA to  $e$ , meeting Be, drawn parallel to CA. Join Ce. Then the triangle CeD is equal to the trapezium ABCD, as the piece cut off the trapezium at B is equal to the piece added on to the triangle at Ac.

The solution really depends upon the proposition of Euclid, "Triangles upon the same base and between the same parallels are equal." The triangles are ABC and AeC, and the parallels

AC and eB; the triangle ACD is common to both the trapezium and the equivalent triangle.

We need not trouble at present with anything relating to angles or *angular measurement*, as in chain surveying we are only concerned with the length of the sides of the triangles, and from these lengths the work can be plotted and the areas calculated without knowing what the angles are.

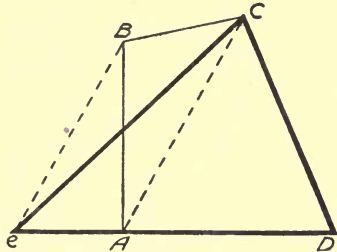

FIG. 6.—To make a triangle equal to a given trapezium.

**Old and modern systems of surveying.**—In the old system of land surveying, each field was measured separately, often by the village schoolmaster, and added on to the bulk already measured, large estates being sometimes checked by the theodolite used round its boundary.

In the modern system, if there are several fields, a base line or two main lines are laid out, running to each extreme of the survey, and triangles are set out from these following the irregularities of the various boundaries, so that the whole is tied into a network of triangles with the fewest possible lines.

In large surveys the theodolite is used to measure the angles of the main lines, in order that the distances may be checked by calculation, as will be shown later.

TABLE OF LINEAR MEASURE.

Inches.	Links.	Feet.	Yards.	Poles.	Chains.	Furlongs.	Miles.
7·92	1						
12	1·515	1					
36	4·545	3	1				
198	25	16·5	5·5	1			
792	100	66	22	4	1		
7,920	1,000	660	220	40	10	1	
63,360	8,000	5,280	1,760	320	80	8	1

## PRACTICAL SURVEYING

TABLE OF SQUARE MEASURE.

Sq. Links.	Sq. Feet.	Sq. Yards.	Perches.	Sq. Chains	Roods.	Acres.	Sq. Miles.
2·296	1						
20·661	9	1					
625	272·25	30·25	1				
10,000	4,356	484	16	1			
25,000	10,890	1,210	40	2·5	1		
100,000	43,560	4,840	160	10	4	1	
64,000,000	27,878,400	3,097,600	102,400	6,400	2,560	640	1

## QUESTIONS ON CHAPTER I.

1. Give a brief description of land surveying under the two heads of field work and office work.
2. Draw two lines at right angles to each other by a rule and set square, and test them by geometrical construction.
3. Draw the outline of one of your set squares, and by construction drop a perpendicular from the largest angle to the opposite side.
4. Measure the length of the sides of a set square, and draw a similar triangle whose sides are half the length.
5. Repeat the last triangle on both sides of the longest line as a common base, and draw a single triangle equal to the combined area of the two.
6. Describe the general principles upon which a survey is made.

## CHAPTER II.

Linear measurement—British standard of length—Units of measurement—Units adopted in measuring land—Form of working in calculating area—Pointing off—Rule for area of rectangular figure—Example—Rule for area of triangular figure when base and perpendicular are given—Example—Rule for area of triangular figure when sides only are given—Example—Rule for area of four-sided figure, having two sides parallel—Example—Irregular four-sided figure divided into two triangles by a diagonal—The same divided into two triangles and a trapezoid—Example—Method of tabulating the working.

**Linear measurement.**—Linear measurement is the measurement of straight lines referred to some known length called a **unit**, or **standard**, of length. This length is purely arbitrary, and differs in different countries. The **yard** is the British standard of length. It is subdivided into *feet* and *inches*, and multiplied into **chains** of 66 feet, and into *furlongs* and *miles*. The chain again is subdivided into 100 **links**, each  $\frac{66 \times 12}{100} = 7.92$  inches long, so that the apparently odd length of 7.92 inches is strictly derived from the British yard.

In linear measurement, when the total length of any measured distance is given, it may be stated in different ways. As a general rule, long distances are given in miles and furlongs, or miles and chains, or miles and yards; and short distances in chains and links, or feet and inches.

**Square measure** is called also *superficial measure*, because it is the measure of surfaces. A square foot is a space that measures a foot each way; or a surface measuring half a foot one way and two feet the other way will likewise be a square foot. The term “square feet” must not be confused with the term “feet square.” Thus, 9 square feet make 1 square yard, but the expression 9 feet square means a square each

side of which is 9 feet long, and therefore has an area of 81 square feet. There is as much difference between square feet and feet square as between a horse chestnut and a chestnut horse.

In square measure the denominations most used by land surveyors are **acres**, **roods** and **perches**, any small amount over being put as the fraction of a perch,  $\frac{1}{4}$ ,  $\frac{1}{2}$  or  $\frac{3}{4}$ , whichever is nearest to the true result. Decimal fractions of a perch, such as are recorded in the Ordnance Survey, give the appearance of minute accuracy which, however, the facts of the case do not warrant. It may be taken as a rule that no field survey can be relied upon for accuracy within less than one perch per acre (five-eighths of 1 per cent.), but straight-sided building plots measured with a steel tape may be accurate within a tenth of 1 per cent.

The tables at the end of the last chapter (pp. 5 and 6) give a concise view of the common linear and square measures. In some tables of square measure, areas are stated as acres, roods and poles, instead of acres, roods and perches, as here given. The reason is that the length of  $16\frac{1}{2}$  yards is known as a rod, pole, or perch, and the corresponding square with that length of side as a square rod, pole or perch.

In order to avoid confusion, surveyors have generally adopted the term pole for linear measure and perch for square measure, and it is well to bear in mind this distinction.

**Areas of regular figures.**—We are now in a position to consider the methods of finding the areas of any regular figures or those bounded by straight lines.

**The area of any rectangular figure is found by multiplying together its length and breadth.**

Ex. 1. *In a field 7 chains long and 3 chains wide (Fig. 7) how many acres, roods and perches?*

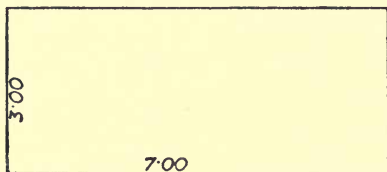

FIG. 7.—Rectangular field.

$$\begin{array}{r} 7 \\ 3 \\ \hline 21 \\ 4 \\ \hline 4 \\ \hline 40 \\ \hline 160 \end{array}$$

Ans. :

2 a. 0 r. 16 p.



*Explanation.* 10 square chains make 1 acre, therefore divide 21 square chains by 10, or, what is the same thing, point off one figure. Then multiply the remainder by 4 to bring to roods and point off. Then multiply the remainder by 40 to bring it to perches and point off. The figures to the left of the pointing show the acres, roods and perches.

**The area of a triangle is found by multiplying together its base and perpendicular height and dividing by 2.**

There is a special reason for not saying multiply the base by half the height, which will be seen later.

Ex. 2. *In a triangular field (Fig. 8), one side of which is 13 chains long, and the perpendicular to the opposite angle 9 chains long, how many acres, roods and perches?*

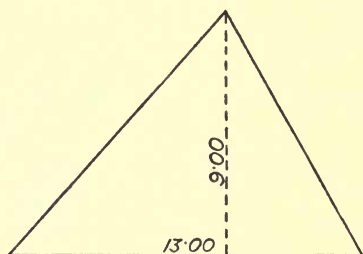

FIG. 8.—Triangular field.

$$\begin{array}{r}
 13 \\
 9 \\
 2 \overline{) 117} \\
 \underline{58\cdot5} \\
 4 \\
 \underline{34\cdot0} \\
 40 \\
 \underline{16\cdot00}
 \end{array}$$

Ans. :  
5 a. 3 r. 16 p.

When the length of the three sides only of a triangle is given, the calculation is a little more complicated. The rule is :

**From half the sum of the three sides subtract each side severally, and multiply it and the three remainders together and take the square root for the area.**

This is usually expressed by the formula,

$$\text{Area} = \sqrt{s(s-a)(s-b)(s-c)},$$

where  $a$ ,  $b$  and  $c$  are the three sides respectively, and  $s$  = half their sum, or  $\frac{a+b+c}{2}$ .

Ex. 3. In a triangular field (Fig. 9) the three sides are respectively 3, 4 and 5 chains long. What is the area?

$$\frac{3+4+5}{2} = 6.$$

$$\begin{aligned} 6-3 &= 3, \\ 6-4 &= 2, \\ 6-5 &= 1. \end{aligned}$$

$$\begin{aligned} 6 \times 3 \times 2 \times 1 &= 36, \\ \sqrt{36} &= 6 \text{ sq. ch.} \end{aligned}$$

$$\begin{array}{r} 6 \\ \underline{4} \\ 24 \\ \underline{40} \\ 160 \end{array}$$

Ans. : 0 a. 2 r. 16 p.

With a four-sided figure having two sides parallel and perpendicular to the base, called by surveyors a **trapezium**, the rule is :

**Multiply the sum of the two parallel sides by the base, and divide by 2.**

Ex. 4. In a field (Fig. 10) with two parallel sides whose

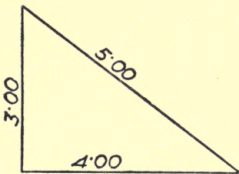

FIG. 9.—Triangular field.

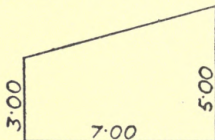

FIG. 10.—Four-sided field having two sides parallel, and perpendicular to the base, called a trapezium.

lengths are respectively 3 and 5 chains long, and their distance apart 7 chains, what is the area?

$$\frac{(3+5)7}{2} = 28.$$

$$\begin{array}{r} 28 \\ \underline{4} \\ 32 \\ \underline{40} \\ 80 \end{array}$$

Ans. : 2 a. 3 r. 8 p.

With irregular four-sided figures there are two ways of finding the area depending upon the angles the sides make

with the base. For instance, in Fig. 11, the area can be divided up into two triangles, with either diagonal as base, from which perpendiculars are drawn to the opposite angles. If both sides make angles of less than 90 degrees with the base,

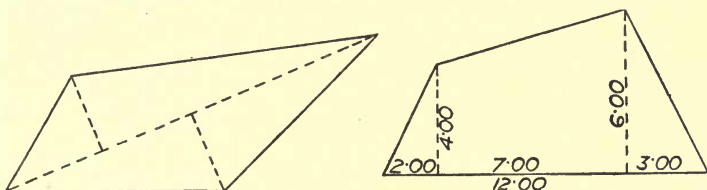

FIGS. 11 and 12.—Irregular four-sided fields.

the method just described is available, and also the method shown in Fig. 12, where, by drawing perpendiculars to the base, it is divided into two triangles and a trapezium.

For the first method the calculations are the same as for a single triangle, the two perpendiculars being added together and treated as one. In the second method the work must be tabulated.

Ex. 5. *A four-sided field whose longest side is 12 chains long has perpendiculars to opposite angles on the same side of base 4 chains long at 2 chains from one end, and 6 chains long at 3 chains from the other end. What is the area?*

4	4	6	2	96
2	6	3		48
—	10	18		4
8	7	70		32
—	70	8		40
	—	96		80
				—

Ans. : 4 a. 3 r. 8 p.

The reason for putting the division by 2 last is that one division suffices instead of one for each part, but care must be taken not to omit it, or it would be as bad as the quantity surveyor who omitted to “twice” his items for the other wing of a hospital.

Generally the measurements are in chains and links, which is the same as units and decimals, but the decimal point is

generally omitted, so that the measurement stands as links only. Then, in multiplying out, the result is given in square links, and as 100,000 square links make one acre, it is only necessary to point off five figures to get acres and decimals.

*Ex. 6. In 285,350 square links, how many acres, roods and perches?*

$$\begin{array}{r}
 285350 \\
 \underline{\quad 4} \\
 341400 \\
 \underline{\quad 40} \\
 \underline{1656000}
 \end{array}$$

**Ans. :** 2 a. 3 r.  $16\frac{1}{2}$  p.

The remainder 0·56 is just over the  $\frac{1}{2}$  perch, which would be 0·5, but it is called  $\frac{1}{2}$  in accordance with the rule laid down. The area could also be written 2·8535 acres.

### QUESTIONS ON CHAPTER II.

1. State what is the British standard of length, and explain how the length of a link in a 4-pole chain is derived from it.
2. What will be the length of a side in feet of a square containing one acre? (**Ans. :** 208·71.)
3. A circular pond is required to contain exactly one acre. What will be its diameter in feet? (**Ans. :** 235·457.)
4. If 25 ordinary walking paces equal one chain, how many paces will there be in a mile? (**Ans. :** 2000.)
5. The three sides of a triangle are 4, 6 and 8 chains long respectively. What is the area in acres, roods and perches? (**Ans. :** 1 a. 6 r. 19 p.)
6. How many acres will be covered by 60 plots of land each 30 feet frontage and 121 feet deep? (**Ans. :** 5 exactly.)

## CHAPTER III.

Drawing to scale or plotting—Description and use of chain scales—Decimal system—Base line of survey—Direction—Points of the compass—Direction of north obtained by a watch—Magnetic meridian—Magnetic variation—North point.

**Drawing to scale.**—Suppose it were desired to mark upon paper certain points representing the distance apart of any objects, say telegraph posts, or to mark the length of any structure, say a fence or building, the actual distance cannot be marked on account of the smallness of the paper; all distances must therefore be reduced in some given proportion, so that when they appear on the paper they give a true idea of their relative values. This is called **drawing to scale**, or, applied to land surveying, it is called **plotting**.

If, for instance, the distance between two points were found to be 3 chains, and it was desired to appear upon the paper about 3 inches long, a scale of 1 chain to 1 inch would be adopted.

**Chain scales** are made of various patterns in boxwood,

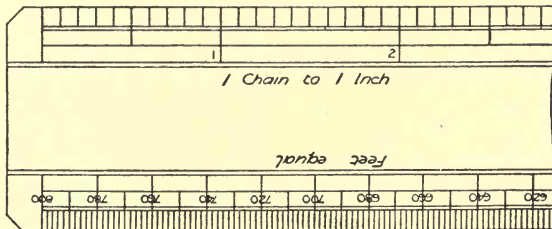

FIG. 13.—Scale of chains and feet corresponding.

vulcanite or ivory, and containing either a single scale each, with “feet equal” on the opposite edge (Fig. 13), or a dif-

ferent scale on each of the two edges (Fig. 14), or containing all the eight usual scales upon one slip, using both edges on

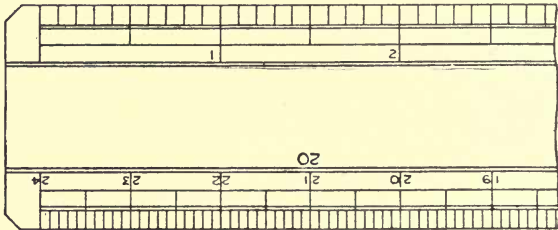

FIG. 14.—Duplex scale.

both sides (Fig. 15). This is called the **Universal Chain Scale**, and is a very handy implement for class use, as all the scales

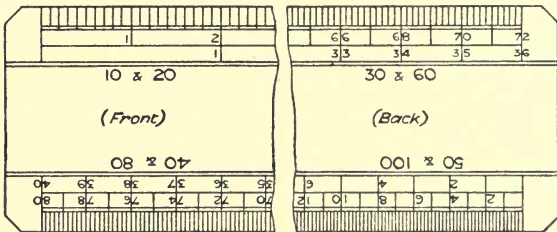

FIG. 15.—Universal chain scale.

are decimally divided. For office work it is usual to have a set of scales similar to Fig. 13 in a box.

There are also special scales to suit special cases; for

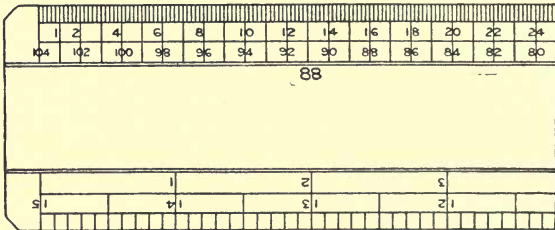

FIG. 16.—Special scale for use on ordnance maps.

example, the most commonly used Ordnance maps are drawn to a scale of 88 feet to 1 inch, or 5 feet to 1 mile, and it may

be desired to scale off a distance either in chains or feet. The special scale made for this purpose is shown in Fig. 16.

Upon the universal chain scale it will be observed that one edge is marked 10 and 20; there are two rows of figures, the one with the widest spaces relating to the 10 scale and the other to the 20. The 10 scale can be used for 1 chain to the inch, or 10 or 100 to the inch; if for 1 chain to the inch, then the smallest divisions will represent 5 links, because there are 20 divisions to the inch, and  $20 \times 5 = 100$ , the

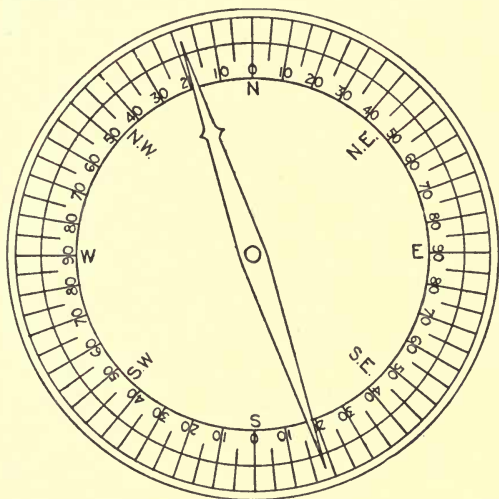

FIG. 17.—Pocket compass.

number of links in a chain. If used for 10 chains to the inch, the smallest divisions will each represent 50 links, and if for 100 chains, each division will stand for 5 chains. All the other scales may be used in the same way, and they may also be used for feet and tenths, so that they become handy for other purposes.

**Base line of survey.**—The longest side of a triangle, or the longest chain line used in making a survey, is generally considered to be the **base line**. A base line must not only be carefully measured, but must be on fairly level ground, and

its direction with regard to the points of the compass must be noted. This is found by means of a pocket compass (Fig. 17), or the compass attached to any of the surveying instruments, or by comparing it with the direction of the shadow cast from an upright stick, by the sun at apparent noon, that is, when the sun has reached its highest point for the day, or is due south, or approximately by means of a watch, as follows :

Stand over the chain line facing the further end, hold the watch so that the hour hand points to the sun. Bisect with the eye the angle between 12 and the sun, producing it backwards to give the direction of true north, note the minute

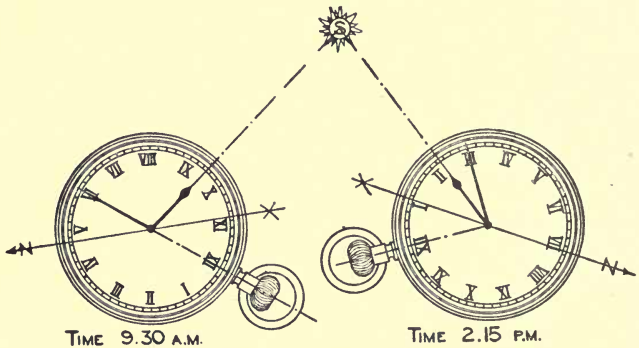

FIG. 18.—Use of watch to find N. point.

indicated by this direction and also the minutes indicated by the direction of the chain line ; then six times the difference in minutes can be plotted as the angle in degrees made by the chain line with true north. Fig. 18 shows two examples of this use of a watch. The shadow and the watch give approximations to the direction of the **true or geographical north**.

**Magnetic meridian.**—The direction in which the north end of the compass needle points is known as the **magnetic north**, and any line coinciding with it is said to be in the **magnetic meridian**. This direction differs from the true north by an amount which differs more or less in different parts of the world and at different times at the same place. It oscillates slowly backwards and forwards during a course of years between about 30 degrees east and west of true north, and is



assumed to point towards the centre of magnetic attraction in the earth, which travels in a circle round the north pole during the same period. There is a daily variation of the needle, as shown by Fig. 19; a monthly variation, as shown by Fig. 20; and also a mean annual variation, as shown by

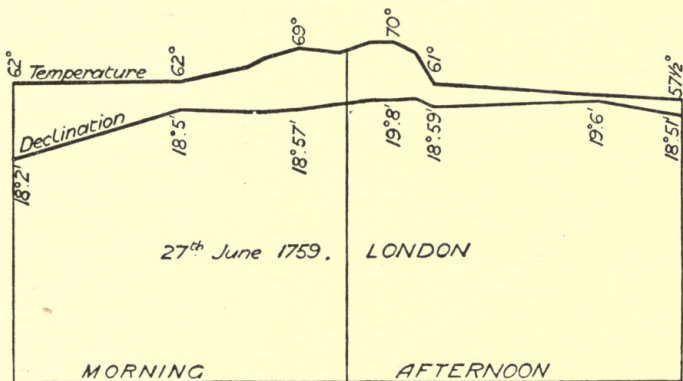

FIG. 19.—Daily variation of compass.

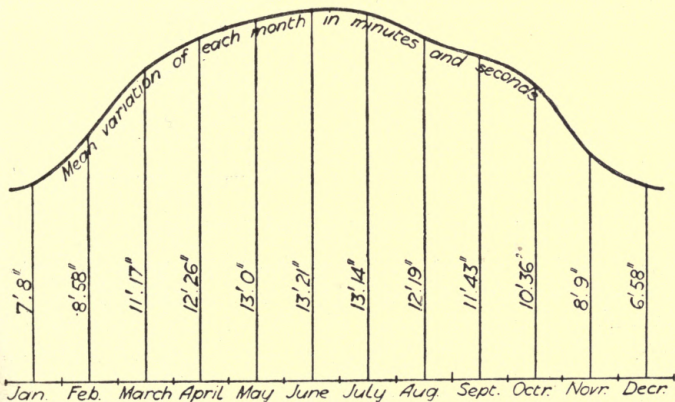

FIG. 20.—Monthly variation of compass.

Fig. 21. In London the mean annual position is now about  $15\frac{1}{4}$  degrees west of true north, and is reducing at the rate of about 7 minutes per annum. The exact variation will be found in the *Nautical Almanac* for the current year.

**The north point.**—In the field-book the bearing of the

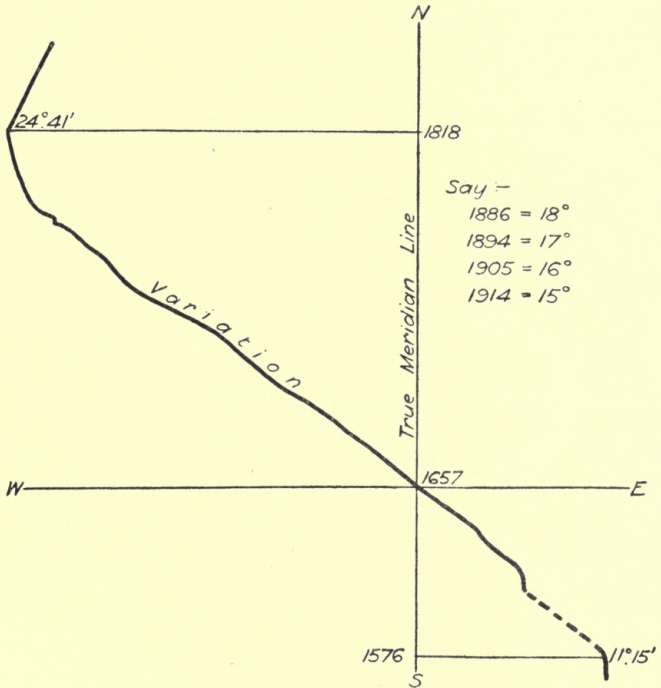

FIG. 21.—Mean annual variation of compass.

base line with regard to the magnetic north is generally entered as so many degrees east or west of north or south; thus, N. 20 W. would mean a direction of 20 degrees west of north, but on all plans, whether manuscript or lithographed, both the true north and the magnetic variation should be shown, in order to make quite clear what the bearing of the plot really is. This is generally done by means of a **north**

point, as Fig. 22, but which may be very much more elaborate. In maps and Ordnance sheets it is customary to make the top of the sheet north, but in detached surveys, if the shape of

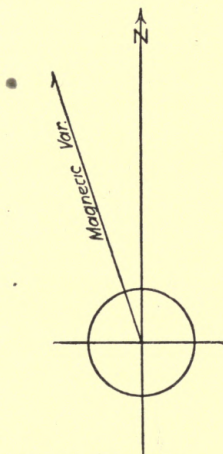

FIG. 22.—North point.

the plot should render it desirable, the plan may be placed in any position, provided the north point is placed accordingly.

### QUESTIONS ON CHAPTER III.

1. What will be the length in inches of a line representing 19 chains  $12\frac{1}{2}$  links to a scale of 3 chains to 1 inch? (**Ans.** :  $6\frac{3}{8}$ .)
2. Make a scale of 40 feet to 1 inch to represent chains and tens of links.
3. Find the area in square yards of a rectangular plot of land, two adjacent sides of which measure 4 chains 34 links and 2 chains 15 links. (**Ans.** : 4516·204.)
4. In 395,590 square links how many acres, roods and perches? (**Ans.** : 3 a. 2 r. 33 p.)
5. A line measures 6 chains 13 links ; what is its length in feet and inches? (**Ans.** : 404 ft. 7 in. nearly.)
6. With a magnetic variation of 16 degrees west, what will be the true bearing of a line whose compass direction is N. 82 W. ? (**Ans.** :  $262^\circ$  or S. 82 W.)

## CHAPTER IV.

Measuring straight-lined figures—Tie and check lines—Rule for distance from angle—Well-conditioned and ill-conditioned triangles—Use of box tape—Measurements put on sketch plan instead of in field-book—Testing tape for shrinkage—Gunter's chain—General description of its use—Tally points—Entries in field-book—Steel tapes.

**Measurement of straight-lined figures.**—In the rules laid down for the mensuration of areas it was assumed that the outlines were more or less regular, and that, for instance, in a rectangular four-sided figure it was only necessary to multiply the length by the breadth. In practice, it must not be assumed that there are any regular figures.

If it were desired to obtain the plan of a single room it would not be sufficient to measure the length and the breadth, and assume the angles all to be right angles, although they might appear to be so; some method must be adopted by which measured lines representing the four sides can be transferred to paper in their true relative positions. It might be divided into two triangles by means of a diagonal across two opposite corners, but in a large room there might be obstructions in the way, and there is another method of which constant use is made in surveying. It is founded upon the method of copying an angle shown among the selected problems in Practical Geometry.

Suppose distances are marked from one of the corners on each of the walls meeting there, and then the distance is measured between the two marks, these three measurements will give the sides of a small triangle, two of which produced to a sufficient length give two of the walls, and the third one is a tie between them, deciding their relative positions.

**Tie and check lines.**—In a four-sided figure (Fig. 23) the measurement of the sides  $a$ ,  $b$ ,  $c$  and  $d$ , and one angle  $e$ , enables it to be put down to scale; but in that case the accuracy of the result depends solely upon the carefulness with which the work has been done, as there is no check upon it. If, however, a second angle be measured,  $f$ , there is a perfect check upon the work, as it would be found impossible to close the figure entirely if a mistake is made in either measuring or plotting any one of the lines. The rule in surveying for

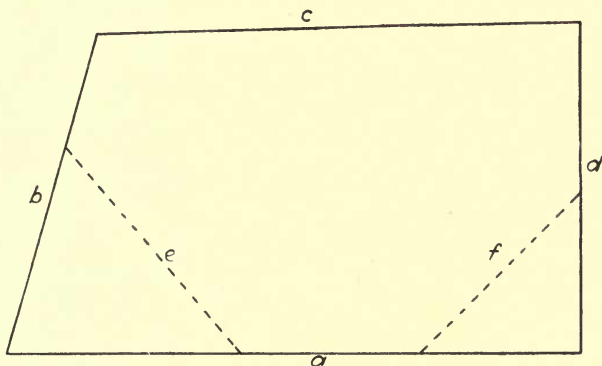

FIG. 23.—Measuring sides and angles of a room.

these **tie and check lines** is that the points should be taken not less than one-fourth of the length of each main line from the angle, and not necessarily at equal distances, so long as the triangles formed are *well-conditioned*, *i.e.* having no angle less than 30 degrees nor more than 120 degrees. An *ill-conditioned triangle* is one that would not conform to these conditions. The rule only applies to ordinary surveys; for important work the complete diagonals should be taken.

**Use of box tape.**—The **box tape** (Fig. 24) is commonly employed for all measurements about buildings and yards, where the general distances are under one chain in length. It is marked off to a total length of 66 feet, one side being divided into feet and inches, and the other into poles and

links, so that either denomination can be used for the measurements.

In using a tape line the starting point is always the furthest extremity of the brass ring. There must be no twist in the tape, and it must be pulled sufficiently tight to prevent the sagging from affecting the measurements. As the surveyor cannot be at both ends of the tape, he takes the box and gives the ring end to an assistant, and, unless the assistant is experienced, care must be taken that he does not take a turn of the tape round his wrist to keep his hold firm.

About buildings and yards the tape is much simpler than the chain, and handier to carry about, and the measurements being short and intricate are generally entered upon a sketch plan instead of in the columns of a field-book.

**Testing tape for shrinkage.**—Although the 66-foot Chesterman metallic tape has wires woven in to prevent

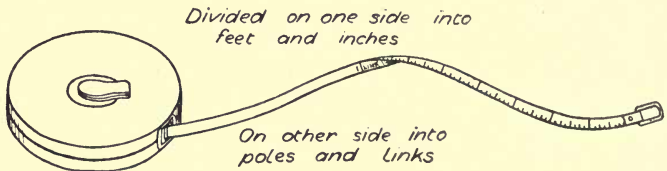

FIG. 24.—Box tape.

stretching, it is worthy of notice that one of these tapes used on wet grass and wound up again was found, when tested two days later at the Guildhall, to have shrunk to 65 feet 4 inches, and when tested three weeks later it had recovered so far as to measure 65 feet 9 inches long. It is useful to practise pacing as a rough check upon distances; a long step is 3 feet or 1 yard, and a natural step or pace about  $2\frac{2}{3}$  feet; therefore multiply the number of paces by 4 and point off two figures; the result is chains and links.

**Gunter's chain.**—For land surveying the chain is always used, but the tape sometimes comes in as an accessory for measuring long offsets. The surveyors' chain is called a **Gunter's chain**, after its inventor, Rev. Edward Gunter, who was a professor of astronomy about the year 1640 at Gresham College. It is sometimes called a 4-pole chain, to distinguish

it from the 100-foot chain used by civil engineers. The 4-pole chain is more useful for land measure, as it is an exact decimal of a mile, one-eightieth, and the square formed by it is exactly one-tenth of an acre. It consists of a series of links and rings (Fig. 25), measuring altogether 66 feet, and is always used on the ground, as its weight would cause it to sag if held up, as the tape often is. It requires at least two operators, the surveyor and his assistant, or surveyor and chainman, or driver and leader.

**Use of Gunter's chain.**—The chain is accompanied by ten galvanised iron arrows or pins, to indicate the various

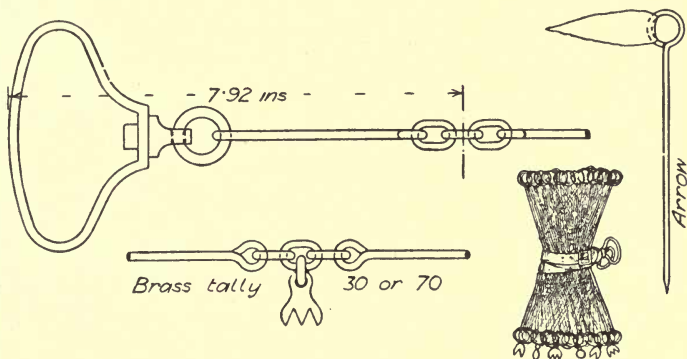

FIG. 25.—Gunter's chain and arrows.

chain lengths as they are reached in a measurement. These are inserted in the ground by the leader and withdrawn by the driver, an exchange taking place at every ten chains which is entered in the field-book. In using the chain the driver passes his fingers through the end ring, holding it vertically on the ground at the starting point; the leader holds the other end leg high, with his fingers through the ring and an arrow held against it by his thumb through the loop; he sees that it is straight, and then watches the signals made by the surveyor with his free hand, the palm of the hand facing the side the leader must go to to put himself in line, and the fingers moved to show it, reversing the palm and movement of fingers when the leader goes too far, and putting the palm

downwards and moving the fingers in the same direction when the leader is in the right spot. As he nears the right spot he will, of course, be stooping down, with the point of the arrow just clearing the ground.

To get the chain to lie straight on the ground, the leader gives the end held by him a few sharp vertical jerks, which causes a wave-like motion to pass along the length of the chain. The jerks must not be too vigorous, or the pull on the chain too tight, as that would cause it to stretch by opening the links.

As soon as the arrow is fixed the two operators walk on for another chain length, unless there are any interim measurements to be made for offsets, or notes to be entered. In the old days there was an eleventh arrow made of brass to insert in the ground when the tenth was withdrawn by the surveyor, but the writer has not seen one for many years, and the custom now is for the surveyor to put his toe on the spot, count the ten arrows at every change, and hand them over to the leader again.

The divisions of the chain are indicated by brass tallies at each tenth link—one point stands for 10 or 90 links, being the same from each end, two points for 20 or 80, three points for 30 or 70, four points for 40 or 60, and a round tally with the maker's name for 50 links. No confusion arises from the number of points being the same for two readings, as it is easy to see which is the nearer end.

**Entries in the field-book.**—In the field-book there is one column only, down the centre. This is for entering any measurement obtained by the chain in a direct line, all the measurements being reckoned from the starting point. The left-hand space is for recording anything occurring to the left of the chain line, and the right for anything occurring on the right. An important and curious point in connection with the field-book is that the surveyor begins at the end and finishes at the beginning, working backwards all the way. He begins at the bottom of the last page and makes his entries consecutively upwards, so that he stands with regard to the book exactly in the same position as he stands with regard to the chain line.

**Steel Tape.**—In modern work a 66-foot or 100-foot steel tape is often used instead of a chain, consisting of a ribbon of



steel  $\frac{1}{2}$  inch wide, with brass plugs riveted in to mark the links. It is more accurate than a chain, but requires more care in handling. A 100-foot standard steel tape is a very delicate instrument, marked in feet, inches and eighths, needing as much care as an infant, difficult to keep free from corrosion and consequent indistinctness of divisions, and only used for building surveys.

### QUESTIONS ON CHAPTER IV.

1. A chain is one link short, next to the 50 tally, a line measured by it is given as 13·47 ; what is the true length? (**Ans.** : 13·34.)
2. A triangular plot of land has its sides 4·32, 3·51 and 2·17 ; plot this to a scale of 1 chain to 1 inch, and find the distance along the base line, from the shortest side, where a perpendicular from the apex would fall. (**Ans.** : 1·28 nearly.)
3. What will be the area in acres, roods and perches of 10 square inches on a map drawn to a scale of 3 chains to 1 inch? (**Ans.** : 9 a. Or. Op.)
4. Describe the instruments used for measuring distances in the field.
5. Describe the operation of poling out and chaining a line in the field.
6. Explain, by a sketch, the reason for measuring check lines as well as tie lines in a survey.

## CHAPTER V.

Measurement of straight-sided fields—Use of station poles—How chain lines and stations are indicated in field-book—Conventional signs—Offsets, how measured and recorded—Examples of offset pieces—Plotting from field notes—Drawing in the outlines.

**Measurement of straight-sided fields.**—In surveying a field with straight sides it is, in theory, only necessary to divide it into triangles and measure the base and perpendicular of each, but in practice very few straight-sided fields occur, and the only spaces of the sort likely to be found are building plots. Generally, the chain lines cannot be laid along the boundaries, but must be some little distance inside them, so that the position of the boundary must be measured by perpendicular **offsets** from the chain line. These offset measurements are put in the right or left-hand column of the field-book according as they occur to the right or left-hand side of the chain line when facing forwards from the starting point.

**Use of station poles.**—The positions of the chain lines are marked out on the ground by light poles, painted in red, white and black bands (Fig. 26), with a small red and white

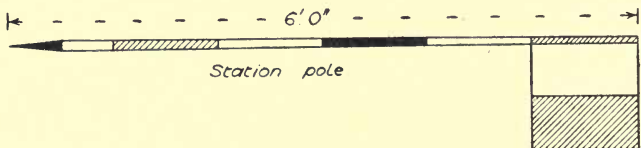

FIG. 26.—Station pole.

flag about 12 in. square nailed on the top, to distinguish them at a distance, a pole being placed at each junction of the

lines and at one or two intermediate points when the line is a long one.

**Conventional signs.**—In measuring the lines, whenever a station pole is reached, the measurement is recorded and the pole indicated in the field-book by a small circle with a dot in the centre (Fig. 27). There are other conventional signs used

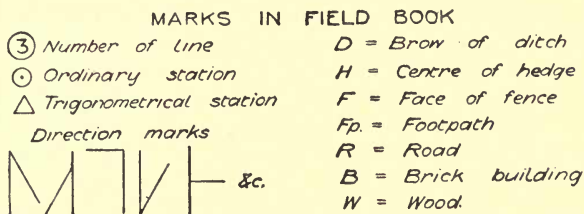

FIG. 27.—Marks in field-book.

by surveyors for indicating in the field-book and on plans the various details of a survey, as roads, fences, footpaths, etc., which are here given. In chain surveying the lines are numbered in the order in which they are measured. It is useful to record the chain lines **on the plan** and show the direction in which they were measured, as in Fig. 28.

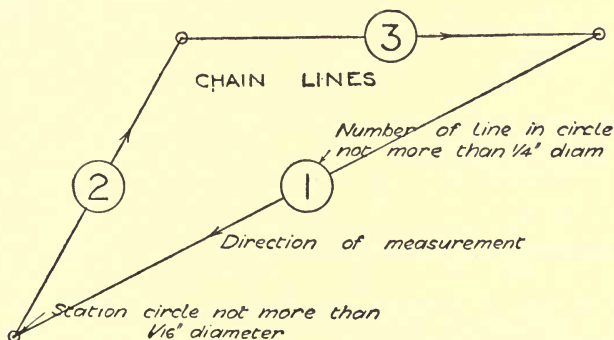

FIG. 28.—Drawing chain lines on plan.

When the offsets are short they are measured by an offset-staff, which is simply a ten or fifteen-link rod, divided into

links, painted alternately black and white, the fifth link having a red ring painted round its end, as in Fig. 29. The end

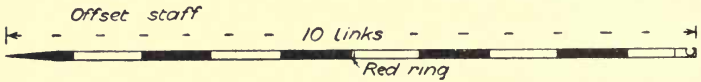

FIG. 29.—Offset-staff.

of the offset-staff is finished with a flush hook for pulling the chain through a hedge. In a well-arranged survey no offset should exceed one chain in length. Sometimes it may happen that there is a strip of grass, a footpath, and a roadway occurring between the chain line and the boundary; with an offset-staff the measurements would be recorded as in Fig. 30,

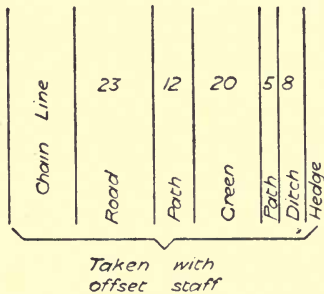

FIG. 30.—Measurements taken with offset-staff.

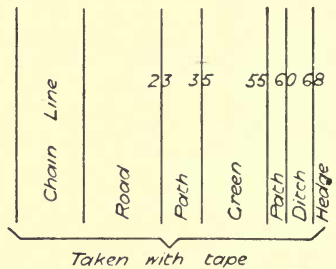

FIG. 31.—Measurements taken with tape.

being placed between the lines to indicate the number of links in width; but time may often be saved by using a tape in such a case, and the measurements would then be continuous from the chain line. This is shown by putting the measurements on the lines, as in Fig. 31, instead of in the spaces.

**Measuring and recording offsets.**—In taking offsets with the staff, the surveyor judges by his eye where the perpendicular from the point required would fall upon the chain line, and then keeping the point in view, he passes the staff hand over hand from the chain to the point. Generally, it is desirable to look round the field and sketch the proposed chain lines in the field-book, numbering them in the order in which they will be measured. Then the surveyor

walks round and puts in the station poles, and is ready to commence chaining.

The first entry in the field-book is the name of the place and the date. After that comes the position of the base line with regard to the points of the compass, or its "bearing."

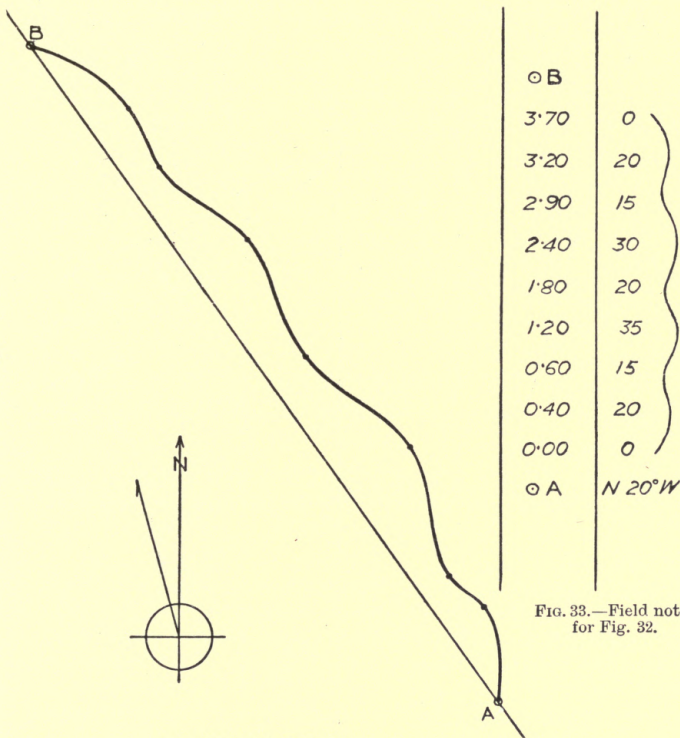

FIG. 33.—Field notes for Fig. 32.

FIG. 32.—Offset piece.

This is generally taken by a pocket compass, and is therefore the bearing from the magnetic north; but, in plotting the plan, due allowance must be made for the "variation of the compass" and both the true north and magnetic north shown by the north point, as previously explained. The approximate

direction of all chain lines after the first may be very clearly indicated by a "signal-post" or mark in the offset column opposite the commencement. The upright or "post" represents the previous line, or line from which the departure is to

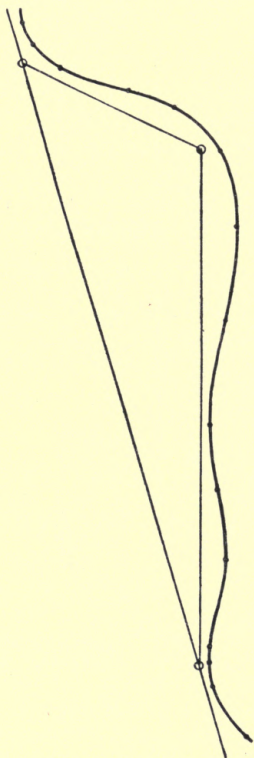

FIG. 34.—Supplementary triangle on chain line.

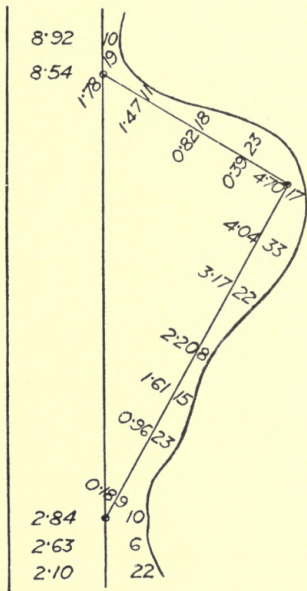

FIG. 35.—Field notes for Fig. 34.

be made, and the "arm" shows the direction taken by the new line. Some illustrations of these marks are shown on Fig. 27. In plotting, the approximate direction facilitates finding the intersecting points in constructing the triangles.

An **offset piece** is the irregular strip of land between a

straight chain line and the boundary, as in Fig. 32, of which the field notes are given in Fig. 33. Where several long offsets would occur, a supplementary triangle should be laid down, the base being on the chain line and the sides approximating to the outline of the field, as in Fig. 34, of which the field notes are given in Fig. 35.

**Plotting from field notes.**—In plotting from the field notes, the base line should be drawn in first, with the correct bearing, taking the total length between the first and last stations, then the lines forming the great triangles, and lastly the check or proof lines. When these agree, the plotting of

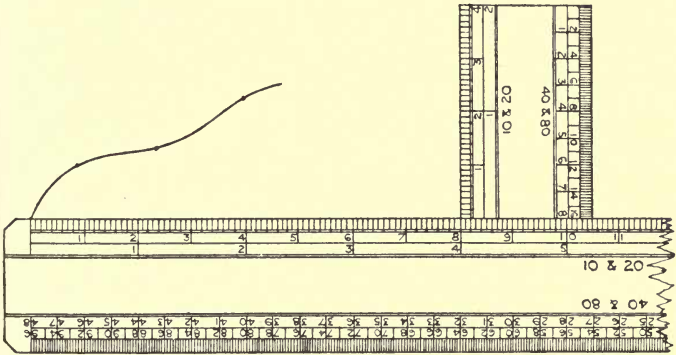

FIG. 36.—Plotting with offset-scale.

the smaller triangles may be proceeded with, and after these the offsets. The importance of having the base and tie lines correctly measured is therefore evident, as if they are wrong all the other measurements are useless, and the work must be done over again.

In a survey occupying more than one day, it is especially desirable to plot the day's work each evening, in order that mistakes may be rectified; and, in fact, however simple the survey may be, the sooner it is plotted the better, the various details being fresh in the memory. On large surveys, with experienced surveyors, the routine is somewhat different, as a survey party may be away from headquarters for many weeks or months, and the practice is to have two field-books,

one being sent to headquarters each week, for plotting by a different set of men, and returned at the end of the week.

**Drawing in outlines.**—Having plotted the chain lines to the most convenient scale, the readiest way to lay off the offsets is to place the chain scale exactly against the line, with its zero opposite the commencement of the line, then to put a leaden weight on each end of the scale to keep it firm, and to slide the offset scale against it like a set-square. A hard pencil, or needle point, or pricker, should be used to mark the various points, as in Fig. 36. No mark is wanted on the chain line, nor any line perpendicular to it, but when the offset scale reaches the right distance along the chain scale, a point may at once be placed at the right distance on the offset scale, reading the distance from the chain line. The points thus found are joined either by straight or curved lines, according to the sketches made in the offset columns of the field-book at the time of taking the measurements, to show the character of the boundaries. French curves should be used whenever necessary to obtain a steady curved outline.

### QUESTIONS ON CHAPTER V.

1. Name the appliances used in simple chain surveying and describe their use.
2. Give an example of the entries in a field-book for a chain line 7·42 long, with offsets to a hedge on the right.
3. Show by a sketch how chain lines and stations are recorded on a survey plan.
4. What is the usual limit for the length of an offset in measuring fields, and what practical reason exists for so limiting the length?
5. What is meant by “magnetic variation”? What are the extreme limits of the variation and what is the annual change in England?
6. Give a sketch showing the use of a supplementary triangle on a chain line and state what advantage results from it.



## CHAPTER VI.

Nature of boundaries—Hedge and ditch—Why hedge is on inside of ditch—Allowance for width of ditch—Owner's side of boundary, how marked—Poling out chain line when view of ends obstructed by rising ground—Numbering and naming stations.

**Nature of boundaries.**—Various methods are adopted for indicating the boundaries of property, and there are comparatively few cases in which a surveyor can tell, by simple inspection, what the precise boundary line is. In the case of a parish, stones or posts are often fixed at intervals, and these are sometimes in such out-of-the-way places that local enquiries have to be made to find them. **Parish boundaries**, if such occur, should always be put upon any survey plan when they can be ascertained. When a brook or running stream forms the boundary between two parishes, the centre is usually the division line, and lawsuits have occurred from the course of the stream shifting by natural causes.

When land is laid out in building plots the boundary of each plot is marked by pegs driven in the ground at the angles, the face of the peg with the number of the plot painted on it, forming the outer boundary, and imaginary straight lines roughly cut in the grass form the division lines between the plots.

With brick or stone walls, the centre sometimes forms the division line, in which case it is called a **party wall**, but in other cases the wall is built entirely on one property, and the boundary line is then the outer face of it. If there are footings, they usually stand on the neighbour's land, and may be built upon or cut off, or proceeded against for trespass as the neighbour may determine.

**Hedge and ditch.**—A hedge without a ditch on either side may be taken as a party wall, the division line being the

centre ; but when it has a ditch, or the remains of one, on one side of it, the ditch with the hedge usually belong to the land on the opposite side of the hedge, the clear side, or brow of the ditch, forming the boundary line as in Fig. 37. This is

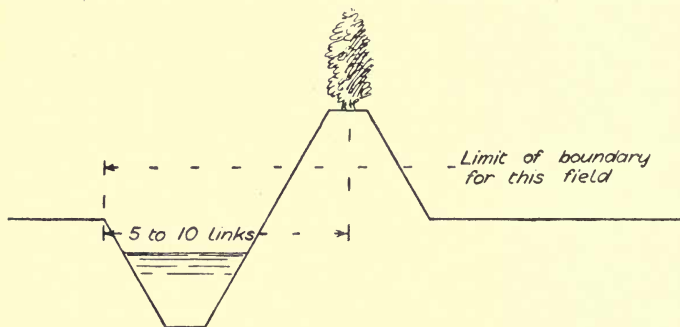

FIG. 37.—Hedge and ditch boundary.

said to arise from the fact that in digging a ditch the earth must not be thrown on to the neighbour's land, but is utilised for planting the hedge. It would, however, be just as easy to dig the ditch sufficiently within the boundary to plant the hedge outside it, and the writer's opinion is that the relative position of hedge and ditch is simply a survival of the old custom, when a wall and ditch were built as protective bound-

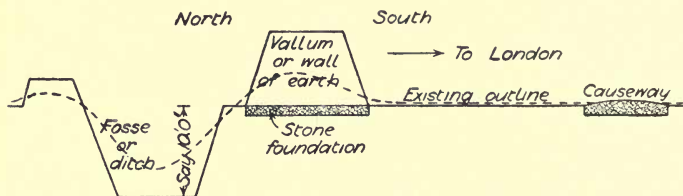

FIG. 38.—Græm's dyke.

daries, as in the case of the Roman wall and ditch, or *vallum* and *fosse*, known as Græm's Dyke, and built by Antoninus Pius between the Forth and the Clyde, A.D. 140, shown in Fig. 38.

If a surveyor is measuring in a field with a ditch belonging to it on the further side of the hedge, he cannot, of course,

get the exact measurement to it in taking his offsets, and he therefore measures to the centre of the hedge, and makes an allowance of 5 to 10 links for the width of the ditch, according to local custom. Usually the allowance is :

5 links when between fields belonging to the same owner.

6 to 7 when between fields belonging to different owners.

7 to 10 links when abutting on public lands.

**Owner's side of boundary.**—With a wooden fence or paling, the face of it is usually the boundary, as in Fig. 39, or

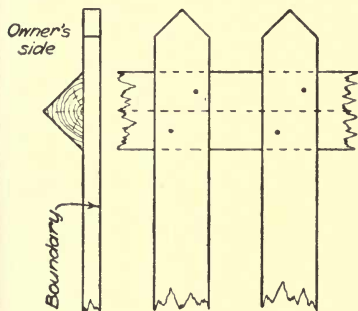

FIG. 39.—Fence boundary.

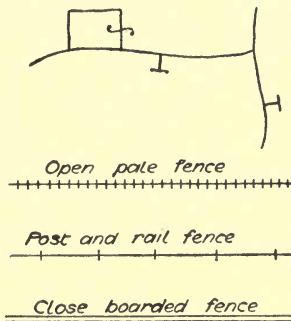

FIG. 40.—Methods of showing fences and boundaries.

as they say, the nails are driven “home,” *i.e.* towards the property to which the fence belongs, so that the owner looks on the back of it; but when the fence is next to a road there is sometimes a ditch outside it to be included in the boundary. With all boundaries of whatever nature, the **owner's side** should be marked on the plans by a letter T placed against it, showing that the fence, etc., as the case may be, belongs to T “this” side, and when a smaller enclosure is taken in with the area of a larger one, a brace or long  $\int$  is put across the boundary, as in Fig. 40.

The simplest fields to survey are three-sided, and in these a single triangle, with offsets, can generally be adopted; but sometimes, if one side is very irregular, a supplementary triangle may be required having a part of the side of the

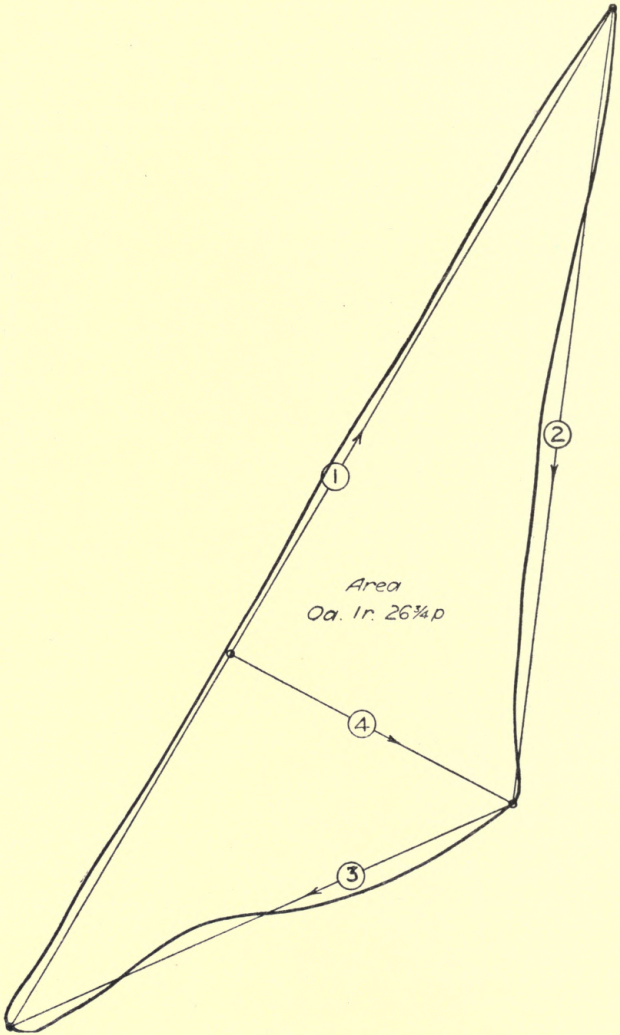

FIG. 41.—Small survey.

original triangle for its base, to avoid long offsets. Before commencing the survey, it is necessary to walk round and notice particularly whether there are any obstructions, at the same time observing which positions for the station poles will

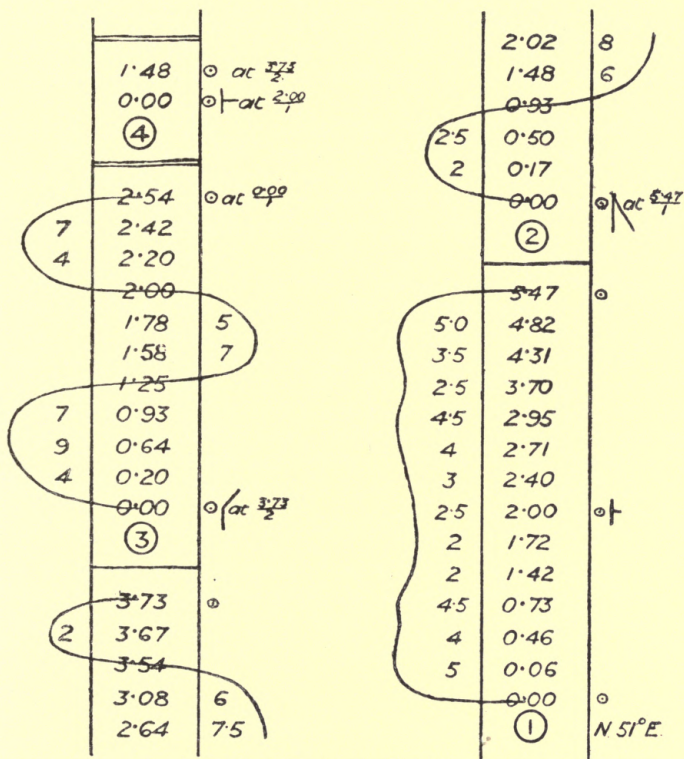

FIG. 42.—Field notes for Fig. 41.

give the longest lines. If the field be small, the arrangement of the lines can be decided upon at once; the station poles can be carried round at the same time and fixed where required, to save unnecessary walking. Although the size and shape of a triangle are determined when the three sides are known,

that is not enough in a careful survey. It is necessary to obtain a check upon the measurements, either by finding the length of a perpendicular, or by finding the length of a check or proof line from intermediate stations on two of the chain lines, not less than one-fourth of their length from the junction. A small survey (Fig. 41) is here given with the field notes (Fig. 42). It is a triangular strip of grass just below the summit of Primrose Hill, in the north-west of London.

**Obstruction by rising ground.**—In this survey, owing to the rise of the ground between, the station poles at either end of the first line could not be seen from the other end, and a method had to be adopted in poling out the line that is often used when surveying over hilly ground. It may be explained from Fig. 43, where A and B are the poles at the extremities of the line. Two operators, C and D, with a pole each, then take up intermediate positions, from which C can see pole B, and D can see pole A. C then signals to D to put him in line with pole B, and D signals to C to put him in line with pole A. With very little labour the poles A, C, D and B will be in true alignment, and the line can then be chained through. It is only necessary to leave in one of the poles, C or D, which can afterwards be used for a check line.

A station is known by its position on the chain line, thus in line 1 the stations are known as  $\frac{0\cdot00}{1}$ ,  $\frac{2\cdot00}{1}$  and  $\frac{5\cdot47}{1}$ , reading 0·00 on 1, 2·00 on 1 and 5·47 on 1; and whenever a station is arrived at a second time it is not only marked in the field-book as a station, but an entry is made against it of its original position, as shown in lines 2, 3 and 4.

### QUESTIONS ON CHAPTER VI.

1. Make a sketch showing the section across a hedge and ditch, and mark, by a vertical arrow, the usual position of the boundary line.
2. Describe and illustrate by a sketch the method of chaining a line when the further end is hidden by rising ground.
3. Give a simple rule for marking stations in the field-book, so that they may be identified when reached a second time.

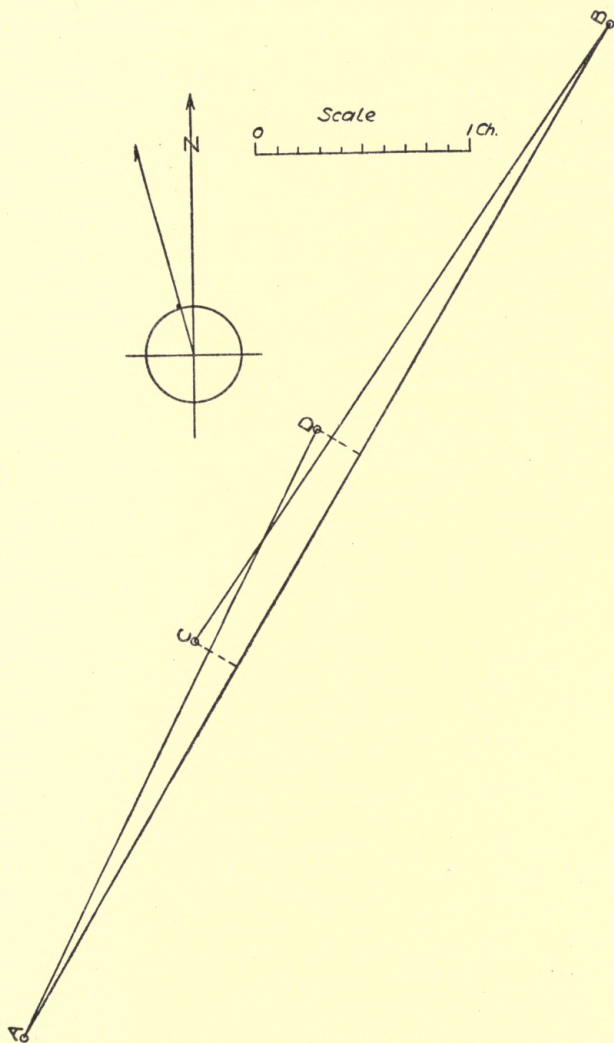

FIG. 43.—Method of poling out the line over hilly ground.

4. Make a sketch of a small field, add chain lines, and make up a field-book to correspond with the plan. State the scale to which it is drawn.
5. In measuring a field with a hedge and a ditch beyond it, how is the width of ditch allowed for?
6. Explain the use of the marks T and  $\int$  on a survey plan.



## CHAPTER VII.

Hedges and trees on plans—Area of field by equalising lines—Area by computing scale—Area by planimeter—Simpson's rule for area—Plotting a survey plan with junctions in boundaries.

**Hedges and trees on plans.**—The chain lines of a survey are not necessarily all within the field or estate, and wherever



FIG. 44.—Sketch of a hedge, magnified.

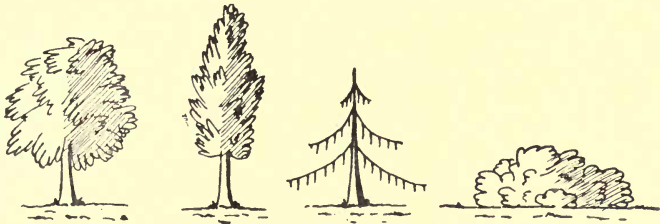

FIG. 45.—Sketches of trees and bushes, magnified.

a better lead can be obtained outside the boundary the lines may be taken there, subject to any "Notice to Trespassers." Hedges on small scale plans are shown by single lines, but on a larger scale they may be sketched with a pen as Fig. 44. Trees may also be sketched as in Fig. 45. These figures are magnified to show the kind of stroke used in making them, but the proper scale must be borne in mind on each plan. Another mode of indicating trees on plan is shown in Fig. 46, which is more in accordance with reality but not so picturesque;



FIG. 46.—  
Another  
method of  
showing trees.

the centre of the cross marks the centre of the tree, but sometimes a section of the tree-trunk is shown.

**Area of field by equalising lines.**—The ordinary mode of obtaining the area of a field or estate is to run **equalising lines** in pencil through the boundaries after they are inked in, and before the plan is coloured; then to divide the whole plot into triangles, measure the base and perpendicular of each, calculate the areas, and total up. An example of this is shown in Fig. 47.

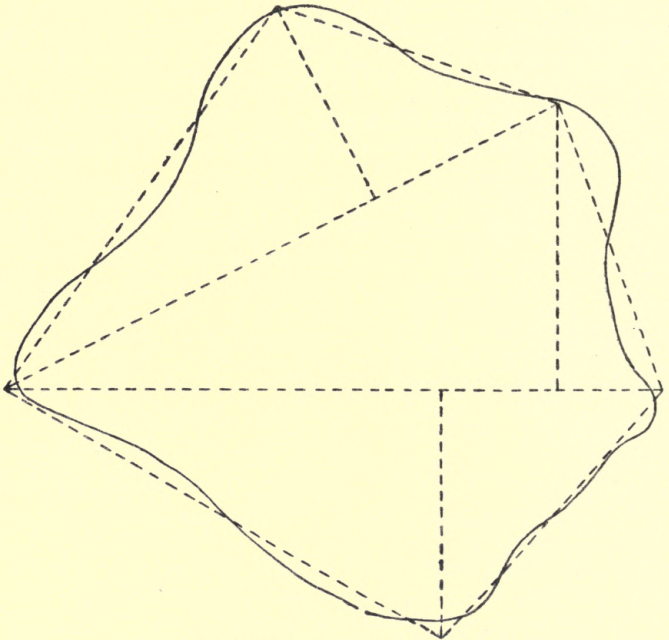

FIG. 47.—Obtaining area of irregular figure.

**Area by computing scale.**—Another method of obtaining the area is by means of a **computing scale** (Fig. 48). To use this, horizontal lines are drawn one chain apart upon tracing paper or upon the plan itself; then it is evident that for every length of 10 chains between two of these lines there will be included one acre.

A different computing scale is required for each different scale; they are usually 24 inches long, set off as shown, the only difference between them being the size of the divisions. The metal frame carrying the wire slides in the central groove and indicates in its passage over the parallel strips of the plan, the number of acres, roods and perches.

In using the scale it is set parallel to the lines across the

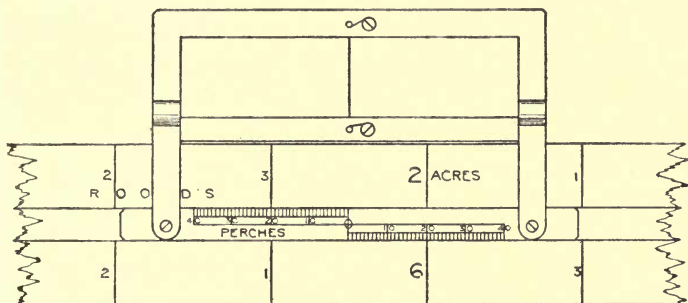

FIG. 48.—Computing scale.

plan, with the wire cutting the boundary as at *c*, Fig. 48A, so as to form an equalising line for the angular piece *ab*. The scale being held, the slide is then moved to a similar position at the other end of the strip, then the scale is lifted bodily and the wire placed over the commencement of the next strip, the scale held and the slide moved.

This goes on until the slide reaches the end of the groove, when a mark is made under the wire, the scale is turned upside down, the wire placed to the same mark and the slide then shifted along the groove towards the commencement again. When the end of the groove is reached, a mark is put under the wire and 8 acres written against it, which is the value of the double travel along the scale. Then the scale is put the right way up again and the slide moved as before. At the finish the slide may be in such a position as shown in Fig. 48, when the reading should be as many 8 acres as had been recorded, plus 1 acre 3 roods 20 perches if the slide was travelling forward, or plus 6 acres

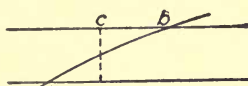

FIG. 48A.—Method of using computing scale.

0 roods 20 perches if the slide had been to the end of the groove and was on its way back.

**Area by planimeter.**—The **planimeter** is another instrument for measuring areas. It is a small and delicate instrument requiring a steady hand, and is used chiefly for obtaining areas from Ordnance maps and parish plans. It consists, as seen by the diagram (Fig. 49), of two arms jointed together so as to

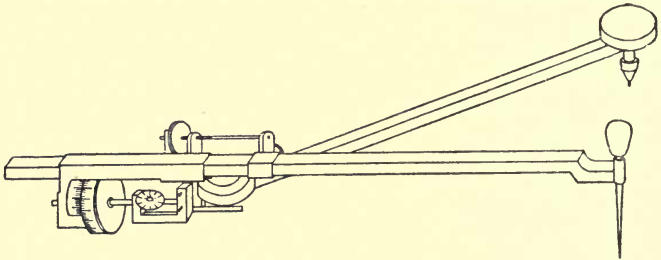

FIG. 49.—Planimeter.

move with perfect freedom in one plane, and a wheel which records by its revolutions the area of the figure traced out by a point on the arm to which the wheel is attached, while the point on the other arm is made a fixed centre about which the instrument revolves.

The principle of its construction is based on Euclid II., 12, 13, and it is fully described in Heather's *Mathematical Instruments* (Crosby Lockwood, 3 vols. in 1, 4s. 6d.), vol. 1, p. 81. In its usual form the wheel has a vernier attached to it, and is connected by gearing to an index wheel which counts the revolutions of the main wheel. The fixed point may be either within or without the area to be measured. In small plots it must be outside, and the reading given by the wheel gear when the tracing point is moved round the whole of the boundary is the area of the figure. When the fixed point is within the boundary, the area of a circle, varying with the size of the instrument, and given by a number stamped on the top of the bar, must be added to the reading.

**Simpson's rule** for the area of any irregular figure is :

Divide the area up into any even number of parts by an odd number of lines, or ordinates. Take the sum of the extreme ordinates, four times the sum of the even ordinates, and twice

the sum of the odd ordinates (omitting the first and last ordinates), multiply the total by one-third of the distance between the ordinates; this equals the area.

In the survey (Fig. 50), of which the field notes are given

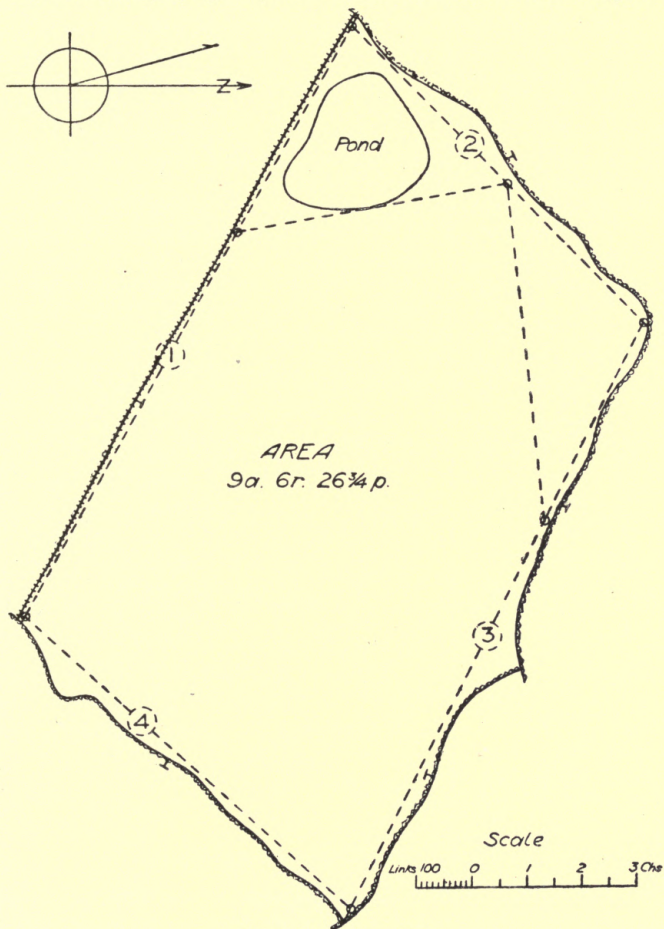

FIG. 50.—Survey of field.

in Fig. 51, it should be observed that the junction of the boundaries with adjacent boundaries should be shown on the

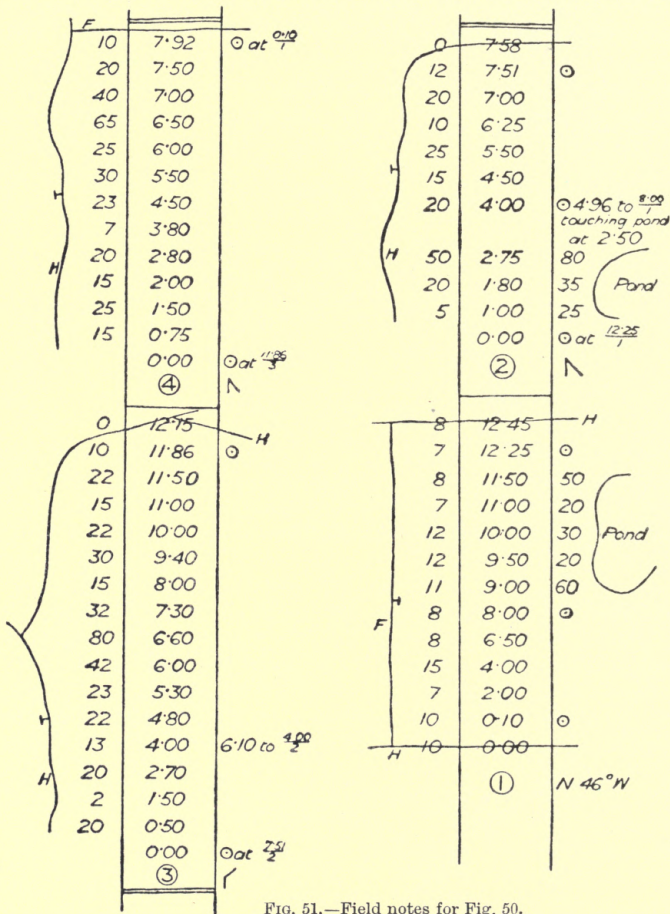

FIG. 51.—Field notes for Fig. 50.

plan, but only to a very short distance, as, no offsets having been taken to these other boundaries, some error might creep in if they were extended more than a few links.

## QUESTIONS ON CHAPTER VII.

1. Show by neat sketches how hedges and trees are indicated on a large scale survey plan. State the scale you have in mind.
2. Make a sketch of a field, and describe how the area is obtained by scaling.
3. Make a sketch of a computing scale, and describe the method of using it.
4. A planimeter is set to the 0·01 in. mark on the arm; after setting to zero and traversing the boundaries of a field on the plan the reading is 2+ on the horizontal wheel, 4 by main divisions and 3 by small divisions on the rolling wheel, and 5 on the vernier. What is the area indicated? (**Ans.**: 24·35 sq. in.)
5. If in the last question the plan is drawn to a scale of 2 chains to 1 inch, what is the area in acres, roods and perches? (**Ans.**: 9 a. 2 r. 38½ p.)
6. A plan was assumed to be drawn to a scale of 3 chains to 1 inch, and the area found to be 10 a. 3 r. 24 p. It was afterwards found that the true scale was 5 chains to 1 inch. What was the true area? (**Ans.**: 30 a. 1 r. 4½ p.)

(NOTE.—In the last answer the ratios of the areas will be as  $5^2$  to  $3^2$ , or 25 to 9.)

## CHAPTER VIII.

Cutting-up a plan, or arranging chain lines, for a survey—Complete survey of small field to explain routine—Office plans and finished plans—Estate in detached portions, how plotted—Colouring plans.

**Arrangement of chain lines.**—It should be considered a fundamental principle that all the main lines of a survey should be so tied together as mutually to check each other, or any one not so proved should have a special check line for the purpose. These check lines may generally be made useful for

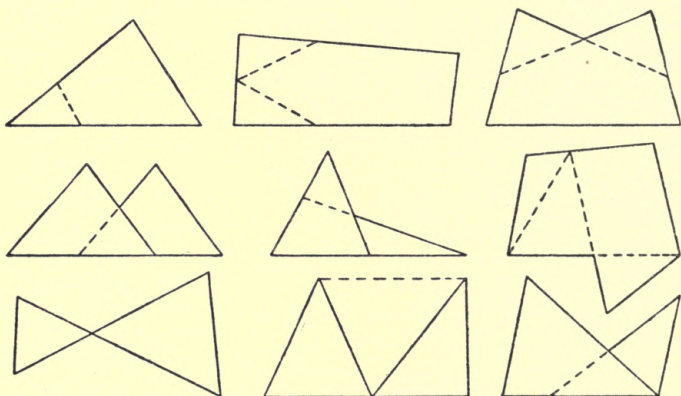

FIG. 52.—Main lines for surveys.

taking offsets from, or getting the position of fences, etc. With a little consideration one check line may often be continued through two or three triangles, and by this much labour is saved.

The base line, or principal line of a survey, should be laid



out on the most level and unobstructed portion of the estate, and should be as long as possible in one straight line, although it may be much too long for making the side of a triangle; in fact, there may be two or three triangles upon it. It should be looked upon as the **backbone of the survey**. Fig. 52 shows some examples of how the main lines may be laid out; generally they appear much more complex, because so many subsidiary lines are required to get the intermediate fences and boundaries. The dotted continuations are the check lines. What are called **false stations** are frequently made in poling out a base line, and the true stations are afterwards placed as the survey proceeds.

**Explanation of routine.**—The small survey shown in Fig. 53 is very suitable for explaining the general routine. The top of the field is bent inwards, forming virtually two sides, as there must be a chain line approximating to each important change in the direction of the boundaries, and this will form a guide in placing the station poles. Having walked from the gate right across the field to see the nature and relative position of the boundaries, a commencement is made at the top right hand corner where a station pole is placed. Then, walking along by the brook, a pole is placed at the further end, near the fence, in such a position that the chain line will just clear the brook from the previous station. Then, walking along by the fence, the buildings are taken into consideration, and, seeing that they are small and unimportant, it is decided to take them by offsets and sketches in the field-book, so the next pole is placed in such a position that the previous station can be seen and a direct chain line obtained to the next angle of the field. Then a pole is put in at the next angle, and the footpath, which is observed to be straight, is crossed, and another pole put opposite the bend, where it projects furthest into the field, in such a position that the pole previously put in, and the one first placed, can both be seen.

Having now obtained all the principal stations, the chaining is commenced from the first pole and continued alongside the brook. While proceeding, a look-out is kept and the distance on the chain line noted and entered in the book where a line through the fourth and fifth poles would fall. Another station pole is put in here; or, if short of poles, an arrow with

# SURVEY OF BROOK MEADOW

IN THE PARISH OF  
LONGMEAD  
FOR ALEXANDER JONES ESQ.

BY  
Henry Adams, F.S.I.  
Surveyor &c

Scale—1 inch to 1 chain

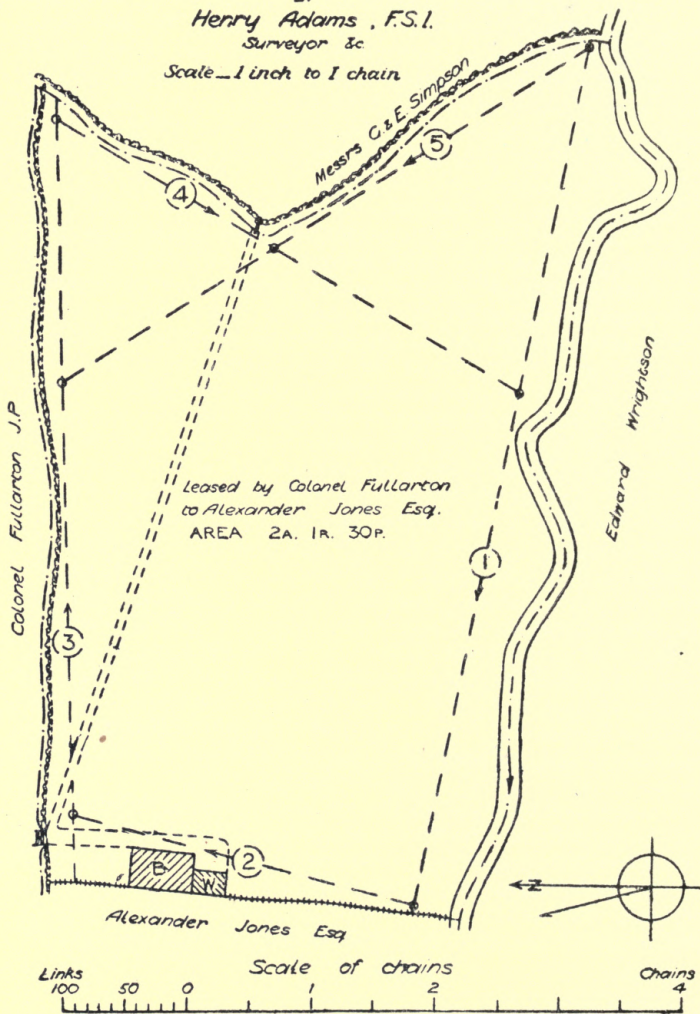

FIG. 53.—Survey of Brook Meadow.

a small white flag tied to it, as in Fig. 54; or a "white," which is a twig with a piece of white paper inserted in a single slit or in a cross slit, as Fig. 55.

On completing the first chain line, the second is started, taking care to note in the field-book everything occurring to the right or to the left of it, or crossing it.

In commencing the third line it will be found necessary to start some distance back from the station, against the fence,

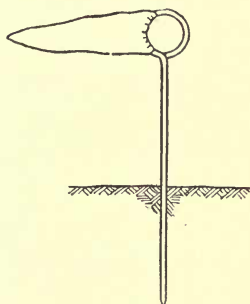

FIG. 54.—Arrow "white" to denote subsidiary station.

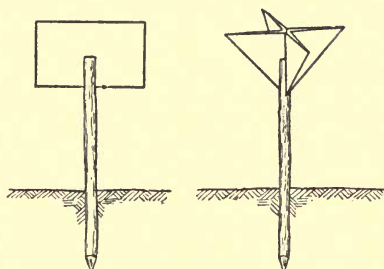

FIG. 55.—Ordinary "whites."

in order to get the road, gate, and boundary properly shown by offsets. Then, on this third line, when the point is reached where a line through stations 1 and 5 would fall, it is marked by a "white." Line 4 is continued through station 5 and up to the "white" which had been left on the first line. And, finally, line 5 would be measured from station 1 through 5 to the "white" on line 3. The continuation of line 4 between lines 5 and 1 forms a "tie," and the continuation of line 5 between lines 4 and 3 forms a "check," or both these continuations may be looked upon as "ties," and then line 2 forms the check.

The field book for this survey is given in Fig. 56. In plotting the work, which is reduced to half size for printing, it should be remembered that a surveyor's duties do not end in the field, and that unless he is able to submit a fairly presentable plan to his employer, he loses credit for skill in his work, and no one would trust a surveyor who cannot

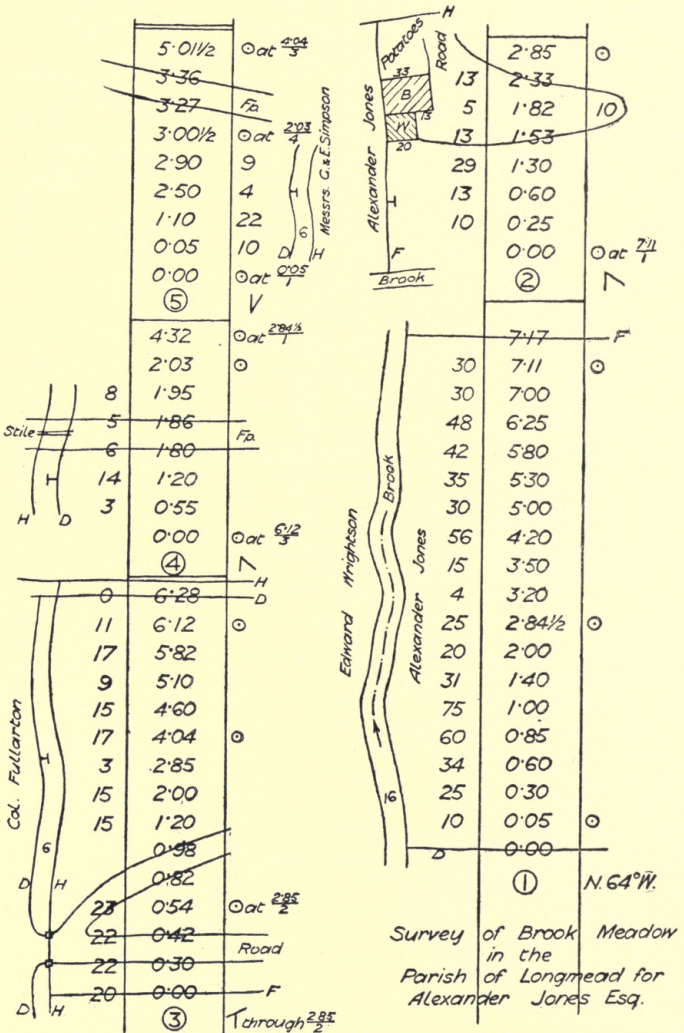

FIG. 56.—Field notes for Fig. 53.

make a neat plan of his work. Neatness and accuracy generally go together.

**Office plans and finished plans.**—Survey plans of estates are usually of two kinds : office plans and finished plans.

**Office plans** have little or no colour upon them, and the chain lines are shown in crimson lake with the number, direction, and station points, as shown in last chapter.

On **finished plans** neither chain lines nor stations should appear, and, according to the purpose for which the plan is required, so would be the expenditure of labour upon it in printing and colouring.

When an estate consists of detached portions they may appear on separate sheets in the office copy, but on the finished plan they should, when possible, all be placed upon the same sheet in their true relative positions and with one north point only. Office plans are drawn to a large scale for obtaining the area, but are often reduced upon the finished plan for sake of appearance.

**Colouring plans.**—When there are any large washes of colour to be put on, or the plan is likely to be long in hand, it may be strained down on the board by damping and glueing the edges, but otherwise this is neither necessary nor desirable. The effect is increased when the green tint used for pasture land is varied in adjacent fields. Hooker's green No. 2 may be used in a pale tint, with more or less of Hooker's green No. 1 added. Any blue and any yellow mixed will make a green of some sort, but anything approaching emerald green should be avoided. Arable land may be coloured a pale brown by using a light tint of burnt umber or sepia. Roads are coloured with Roman ochre. Trees and hedges are shown in a darker green. Water is tinted with Prussian blue, dark at the margin and softened towards the centre. Brick buildings are shown in crimson lake. For wooden buildings Indian yellow or Indian ink is used. Property surrounding the estate is always left uncoloured, the only departure from the rule being that buildings beyond the boundary are sometimes hatched in black.

The area of the various fields is frequently marked upon the centre of each, together with the name of the field, if it has one. In other cases the fields are lettered or numbered, and a reference table is put in the corner of the plan, the area

of each field is given separately, and the total added up at the bottom. The title or heading to the plan may be put in ornamental lettering on the finished plan, but on the office plans plain block letters are quite sufficient. The north point must always be put on the plan, and it is useful to show both the true north and the magnetic variation.

### QUESTIONS ON CHAPTER VIII.

1. Make a sketch of four adjacent fields, and show how you would lay out the chain lines.
2. What are "whites" in a survey?
3. What colours are used in finishing a survey plan? How are buildings indicated?
4. Print neatly, in plain block letters  $\frac{3}{8}$  inch high, the words "Survey Plan of," and underneath, in ornamental letters  $\frac{1}{2}$  inch high, the word "Estate."
5. What are "false stations" in a chain survey, and what is the advantage of using them?
6. Describe the method of undoing a chain preparatory to making a survey and doing it up again after completion.

## CHAPTER IX.

Surveying woods, lakes, marshes, standing crops, etc.—Example of survey of a wood and a lake—Measuring past obstructions—Cross staff, construction and use—Optical square, construction and use—Setting up perpendiculars by chain only.

In surveying **woods, lakes,** and sometimes **standing crops, swampy ground,** etc., by the chain, a system of triangulation has to be laid down outside the boundary, and this always involves more difficulty than measuring open land, and more labour compared with the area, than when the lines can be run inside the boundary. An example of the survey of a wood is given in Fig. 57 (p. 56) with the field notes in Fig. 58, and the survey of a lake is given in Fig. 59 (p. 58) with the field notes in Fig. 60.

**Survey of a lake.**—In the latter case, it will be observed that the brook feeding the lake is just under a chain wide, and the end of the first chain would fall in the water if measured direct. The figures at the side, crossed through, show how the matter was dealt with. The line was first measured to the edge of the brook in line with the station poles, the end of the chain was then carried across the narrow part further up and the width measured on the chain line; the chain then pulled forward to where the end of the second chain would fall, and the line then proceeded in the ordinary way.

**Measuring past obstructions.**—In measuring past obstructions, one of the first necessities of the surveyor is to be able to set up a true perpendicular; this is easily and effectively done with the **cross staff** or the **optical square**.

One form of the **cross staff** is shown in Fig. 61; this has a cylindrical body, with a compass on the top, and having at the lower end a socket to go on a stick, or a screw to go on a

tripod. Smaller instruments are octagonal, with a plain socket and without a compass. They all have slits on four sides, *i.e.* at the extremities of two diameters at right angles to each other. These slits are narrow for half their depth and wide for the other half; the wide part contains a wire or horse-hair, and the narrow part is left plain for sighting

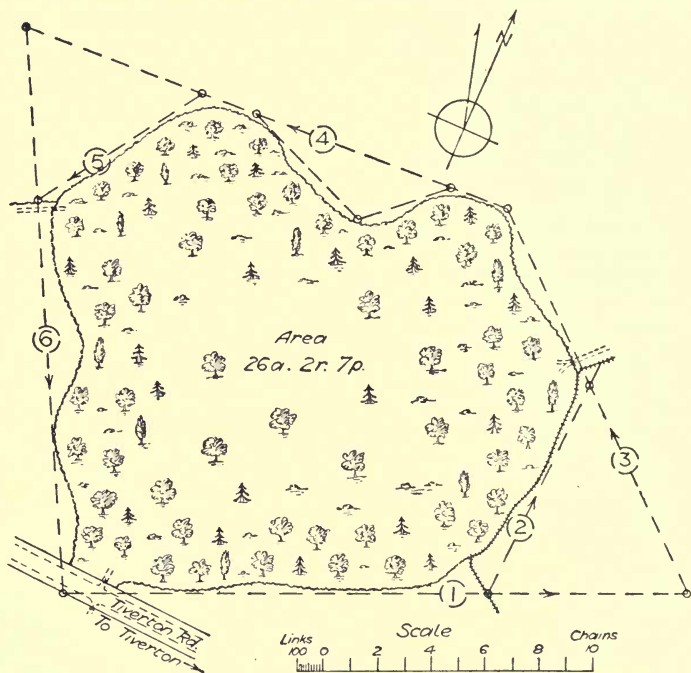

FIG. 57.—Survey of a wood.

through. The narrow part on one side is opposite the wide part on the other side, so that, in looking through, the wire may be sighted with the station pole at each end of the chain line. Then, looking through the slit at right angles, an assistant may be directed to place a pole to be cut by the wire, which will then give a line at right angles to the chain line. A simple form of cross staff may be made by saw cuts



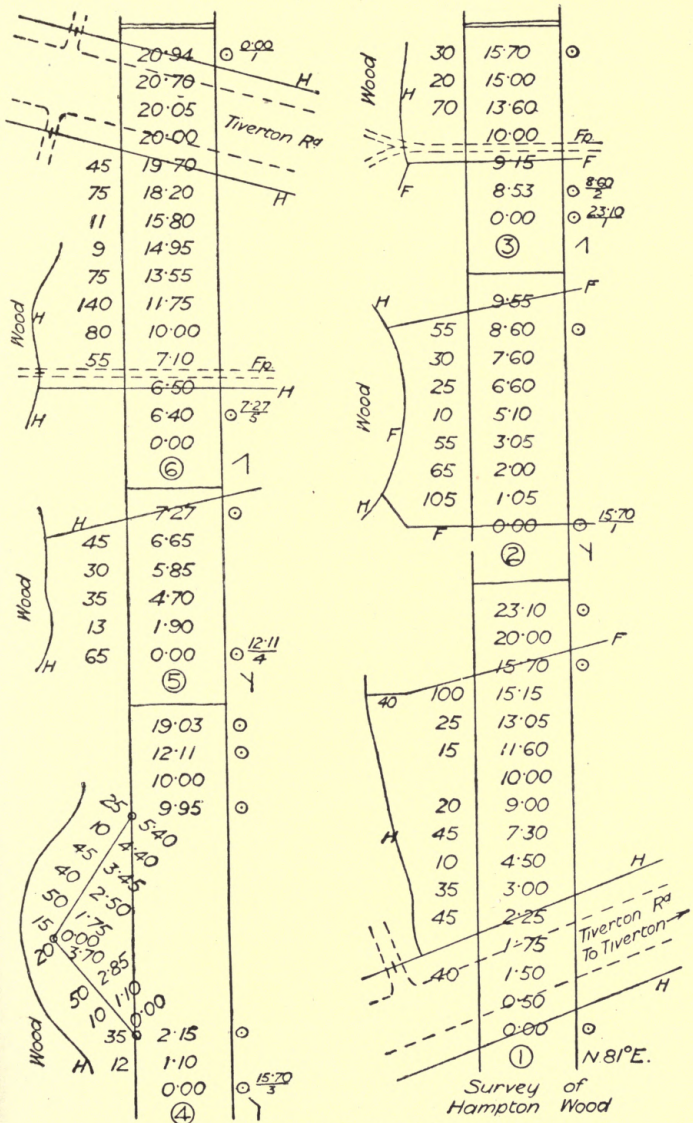

FIG. 58.—Field notes for Fig. 57.

in a disc of wood, say 6 inches diameter and 1 inch thick, fixed on a pointed stick about 4 feet long.

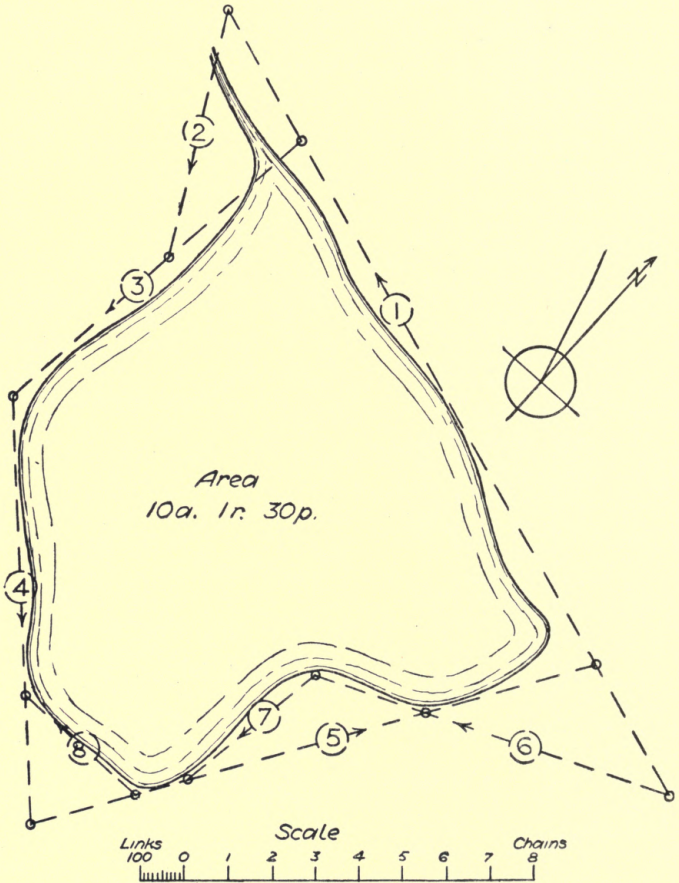

FIG. 59.—Survey of a lake.

The **optical square** is a small circular bronze box about  $2\frac{1}{4}$  inches diameter and  $\frac{1}{2}$  inch thick, as shown in plan in Fig. 62.

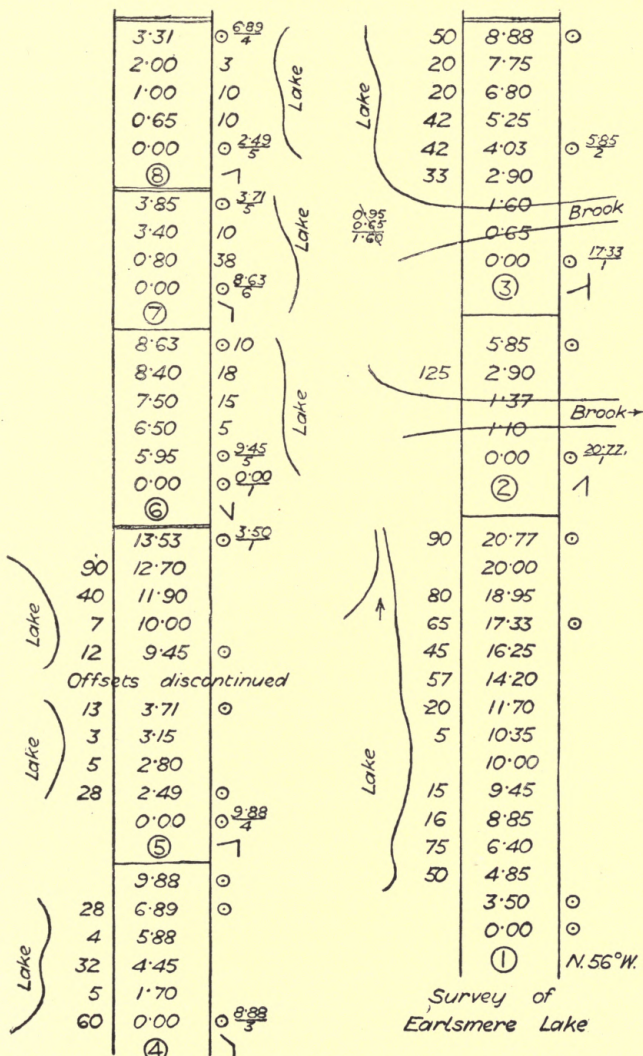

FIG. 60.—Field Notes for Fig. 59.

It contains two fixed mirrors, A and B, and sight hole C. Mirror A is half plain glass and half silvered, as shown in Fig. 63, and B is wholly silvered. In the position shown, the instrument would be held in the left hand, or turned

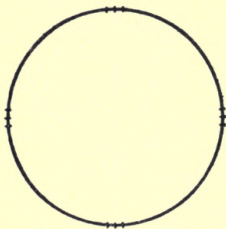
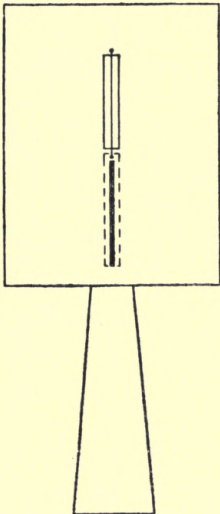

FIG. 61.—Cross staff.

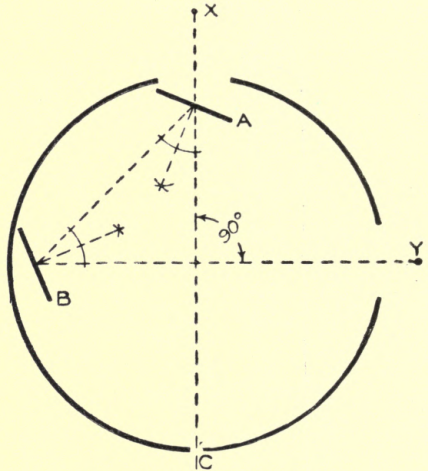

FIG. 62.—Plan of optical square.

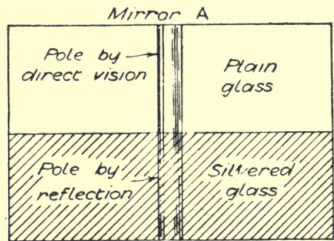

FIG. 63.—Enlarged view of mirror.

over for use in the right hand, according to which side the reflection was to come from. Standing on the chain line and sighting the pole X at the end through the plain part of mirror A, a pole Y may be set at right angles from the position of the

surveyor, the exact spot being determined by the reflection from the pole to mirror B and from there to mirror A, coinciding with the pole X seen by direct vision. The position of the mirrors is fixed by the geometrical construction shown on the diagram, viz. perpendicular to the bisection of the angle found by joining their centres with the two axes, the angle of incidence being equal to the angle of reflection.

**Setting up perpendiculars by chain.**—A perpendicular may be set up approximately by the chain alone, use being made of the well-known property of three lines in the proportion of 3, 4, and 5, forming a right-angled triangle, as in Fig. 64. Let *a* be a point in the chain line, at which a perpendicular is required; measure back 40 links to *b*, and at this point put an arrow through the 80th

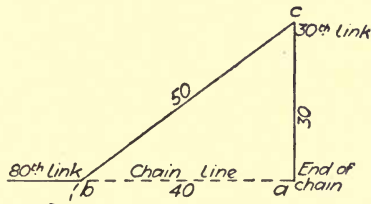

FIG. 64.—Setting off right angle with chain.

link, fix the commencement of the chain at *a*, and taking hold of the 30th link, pull it steadily and gently until the sides *cb* and *ca* are tight and straight; then *ac* will be a perpendicular, and may be extended to any required length. Although in theory this method is perfect, in practice it cannot be relied upon to give the perpendicular exactly, and an error of 2 to 3 inches in a chain length may easily occur.

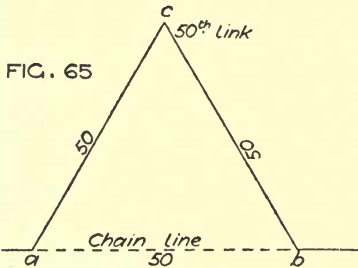

FIG. 65

FIG. 65.—Setting off 60 degrees.

Another useful direction is an angle of 60 degrees, which, being repeated, makes an equilateral triangle (Fig. 65). Measure 50 links back and fix the ends of the chain at *a* and *b*; take the 50th link, and pulling equally, *abc* will be an angle of 60 degrees.

The best perpendicular with the chain is obtained by

pegging down the ends as in the last figure and marking point *c*; then, reversing the chain to the other side of the line, mark point *d*, as in Fig. 66, *cd* is then at right angles to *ab*.

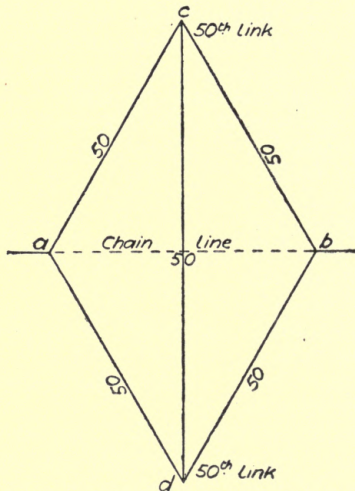

FIG. 66.—Setting off perpendicular to line.

### QUESTIONS ON CHAPTER IX.

1. Show by a sketch how you would lay out the chain lines for making a survey of a small compact wood of, say, 2 acres in extent.
2. Sketch and describe the use of a cross staff.
3. What is the use of an optical square in a survey? Make a sketch of one full size, and describe its construction.
4. In setting out a rectangular plot of land with the chain only, how would you ensure the perpendicularity of the sides?
5. Show by a sketch how you would make a survey of an approximately circular gravel pit 20 yards across.
6. An optical square is found to be out of adjustment; describe how you would set off a true right angle with it in that condition.

## CHAPTER X.

Measuring gaps and detours, view unobstructed—Special precautions when view is obstructed—Measuring across a lake, quarry or bend in river—Measuring across a stream, river or valley—Example of survey at Hilly Fields.

**Gaps and detours.**—The simplest case of obstruction to the chain line is a pond, or bend in a brook or river, or a piece of marshy ground, or a gravel pit or quarry, where the direction is entirely visible but the ground cannot be walked over. In such cases the true distance is required from the point where the chain line breaks off to where it is again resumed; and frequently offsets are required at the same time to the outline of the obstruction.

To take the case of a bend in a stream (Fig. 67), the chain

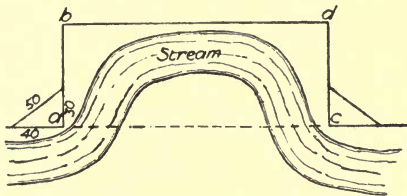

FIG. 67.—Chaining round bend of river.

line proceeds up to *a*, and a perpendicular is there erected and extended to *b*, making *ab* of sufficient length to clear the obstruction. Fix a pole at *c* in the direction of the chain line, setting it true by sighting through, and then set up a perpendicular *cd*, equal to *ab*. The length *bd* will be equal to *ac*. Remember to take offsets wherever necessary. If the perpendicular required is very short, the offset staff may be used, being

placed by the eye, but this should only be done when it is within, say, 15 links.

Another method of making a detour would be as shown in Fig. 68. Measure back 50 links from  $a$ , set up an angle of 60 degrees from  $b$ , continue  $bc$  to such a point  $d$  that an angle of 60 degrees from  $bcd$  would clear the obstruction, then at  $d$  set off an angle of 60 degrees and place a pole at  $e$  in such a position that it sights truly with the chain line and also with the angle from  $d$ . The length  $be$  will be equal to  $bd$ , and also  $de$ , which latter can be measured as a check. Or the

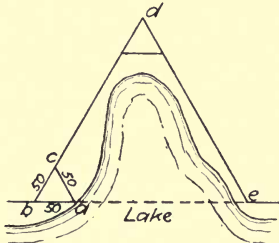

FIG. 68.—Chaining round bend in lake.

distance  $de$  can be chained through, equal to  $bd$ , and if correctly worked the point  $e$  will sight truly with the chain line.

Another mode of measuring the omitted portion of a chain line when the direction is visible is shown in the next diagram (Fig. 69). A triangle is laid out, all the lines measured, and the necessary offsets taken. In plotting the work, the omitted portion is calculated by the formula given and checked by drawing the complete triangle, or, without calculating, the triangle may be plotted to a large scale as in Fig. 70, and the distance  $ad$  measured off.

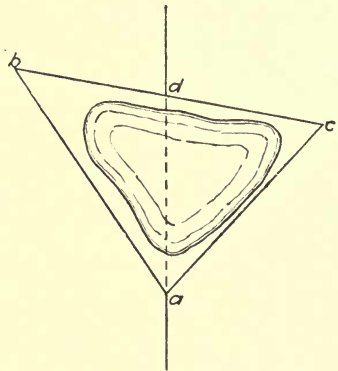

FIG. 69.—Measuring omitted portion of chain line.

When the view is obstructed, extra precautions have to be taken to ensure the chain line being continued in the exact direction required. In such a case, as Fig. 71, the following method may be adopted: Set up equal perpendiculars from  $a$  and  $b$ , of the requisite length to clear the obstruction, taking care that the distance apart is twice the length of the perpen-



diculars. Then before going further check the two diagonals  $ad$  and  $cb$ , which should be equal to one another; and  $cd$  which should be equal to  $ab$ . Continue the line  $cd$  sufficiently beyond the building, tree, or other obstruction, to be able to repeat the

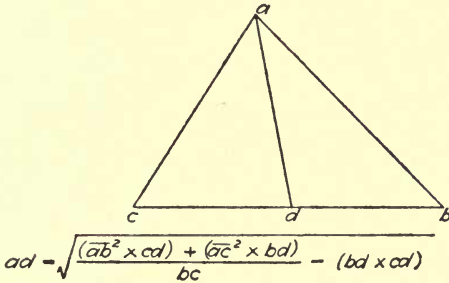

FIG. 70.—Drawing to check same.

operation with exactly the same measurements on the other side. Make  $ef$  equal to  $ab$ , the perpendiculars  $eg$ ,  $fh$ , equal to  $ac$  and  $bd$ , and the diagonals  $eh$ ,  $fg$ , equal to the diagonals  $ad$ ,  $bc$ ; then  $gh$  will give the true direction of the chain line, and the distance  $de$  will be equal to the gap  $bg$ .

**Measurement across a river, etc.**—When a river or lake is too wide to be measured by the chain, or when the chain

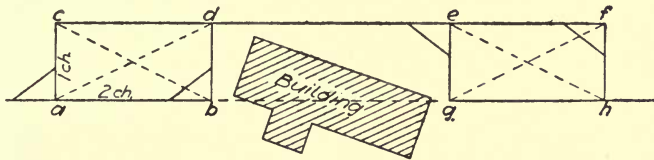

FIG. 71.—Chaining round building.

line has to be continued across them, the distance may be obtained by a practical application of the properties of similar triangles. The simplest case is that of equal triangles, as in Fig. 72. Let  $ab$  be the chain line which it is required to continue across the river, and therefore to obtain the distance  $bc$ . From  $ab$  set up a perpendicular  $bd$  and produce it, making  $de$  equal  $bd$ . At  $e$  set up another perpendicular  $ef$ , and then fix a

pole in such a position that it sights truly with  $cd$  and also with  $ef$ , at point  $g$ . Then the distance  $eg$  is equal to  $bc$ . Point  $c$  is a station pole fixed to sight with the chain line before the measurements begin.

This method answers equally well when the chain line crosses the river at an angle as Fig. 73, the only difference being in the order of laying out the lines. The letters show the order of working,  $d$  is a pole put at any distance along the bank in order that point  $e$  may be found by the cross staff or

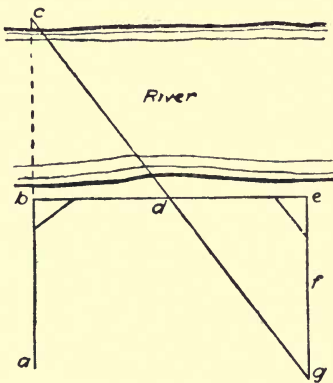

FIG. 72.—Measuring width of river at right angles.

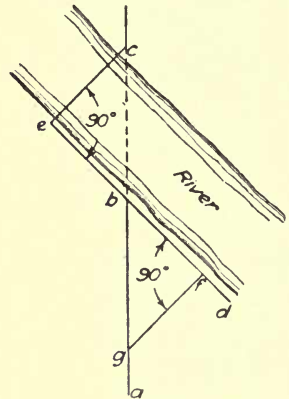

FIG. 73.—Measuring width of river diagonally.

optical square so that  $dec$  is a right angle. Then  $bf$  is made equal to  $be$  and the cross staff or optical square held at  $f$  to direct an assistant to point  $g$ , where he can place himself at the same time in line with  $bc$ , then  $gb$  is equal to  $bc$ .

Another method, which has the advantage of requiring linear measurement only, is shown in Fig. 74. The points  $ab$  and  $c$  on the chain line are first marked by poles, then any point  $d$  is taken,  $ad$  measured and repeated to give  $de$ , also  $bd$  to give  $df$ , then holding a pole the surveyor proceeds to point  $g$ , where he can sight through  $fe$  and  $dc$ . Then  $fg$  will be equal to the required length  $bc$ .

A modification of this method is shown in Fig. 75 applied to the case of a quarry or gravel pit, occurring on the chain

line. The poles *a*, *b* and *c* on the chain line are first set up, and then a pole is set up at *d*, so that both *b* and *c* can be sighted, and

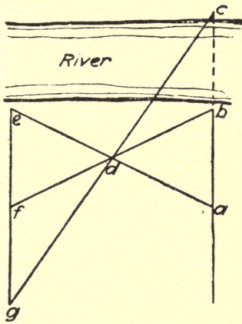

FIG. 74.—Another method of measuring across river.

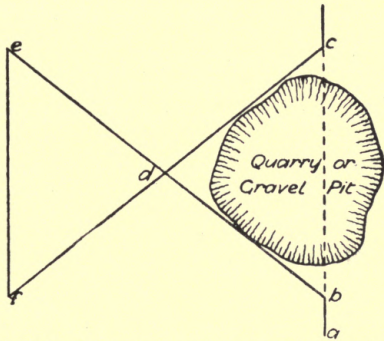

FIG. 75.—Measuring across quarry or gravel pit.

also so that the chain lines clear the edge of the quarry. Continue *bd* and *cd* to *e* and *f*, making *bd* = *de* and *cd* = *df*, then *ef* will be equal to the required distance *bc*.

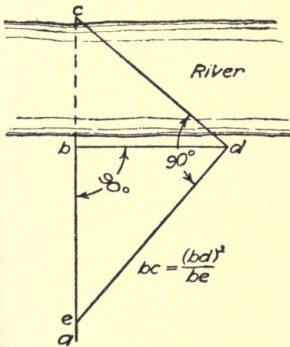

FIG. 76.—Measuring river by cross staff.

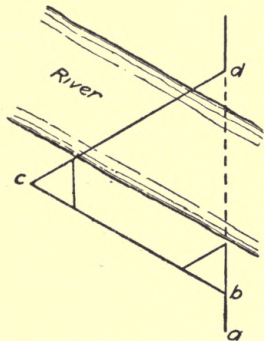

FIG. 77.—Another method.

There is another method of measuring across a river by the use of a cross staff or optical square and a little calculation, as shown in Fig. 76. Take *bd* perpendicular to *ab* and any length.

At  $d$  set the cross staff to sight with  $c$  and direct an assistant to  $e$ , where he places himself in line with  $bc$ .

$$\text{Then } bc : bd :: bd : be, \text{ or } bc = \frac{(bd)^2}{be}.$$

Another method (Fig. 77), is to take the chain line  $ab$  through to  $b$ , and from  $b$  set off a line  $bc$  at 60 degrees with the chain line. From  $c$  set off  $cd$  at 60 degrees with  $bc$ , so that  $d$

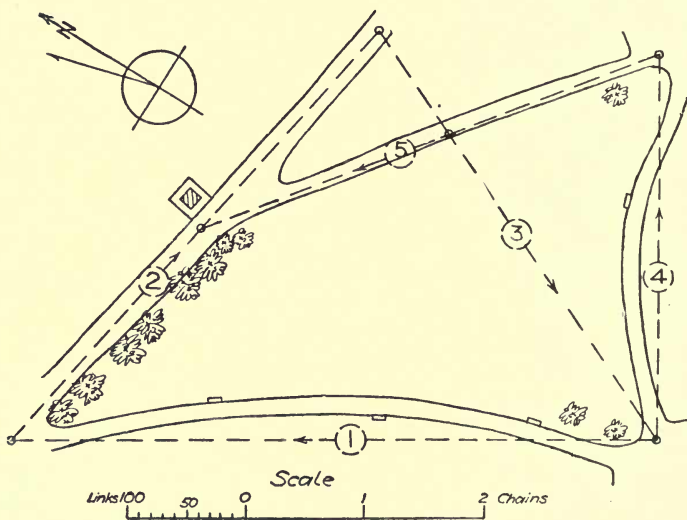

FIG. 78.—Survey of part of Hilly Fields, Brockley.

may be sighted with  $ab$ . Then  $bc$  will be equal to the required distance  $bd$ .

**Example of a survey.**—Fig. 78 shows the survey of a part of Hilly Fields, Brockley, London, S.E., the field notes for which are given in Fig. 79. All the examples given in this series should be drawn out for practice to at least four times the published size, and properly finished and coloured. The principles may be fully understood by merely reading and examining the diagrams, but it is necessary to do the actual plotting to a reasonable scale to obtain the full advantage.

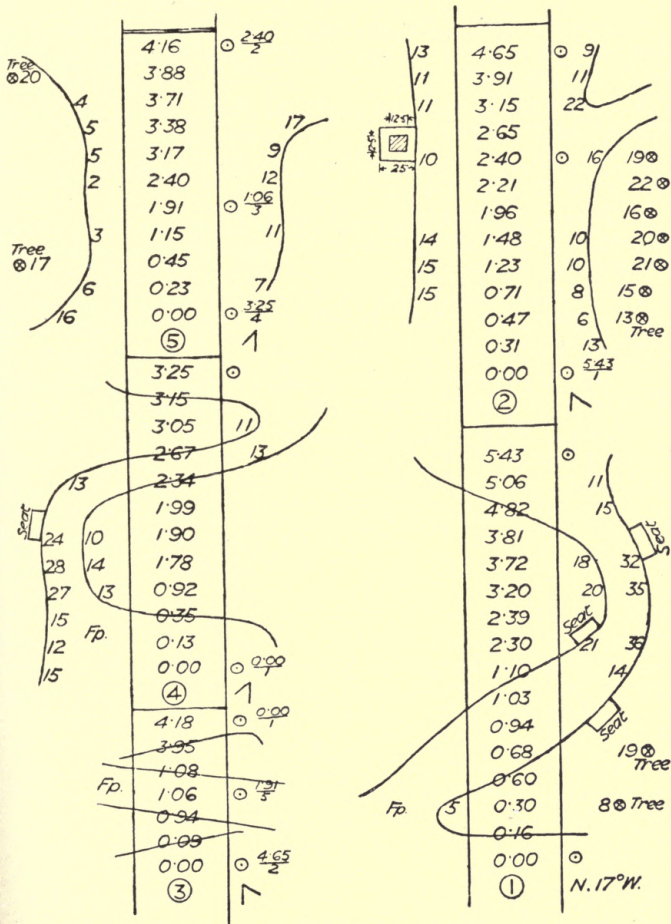

FIG. 79.—Field notes for Fig. 78.

## QUESTIONS ON CHAPTER X.

1. It is found in drawing a line between two stations that the bend of a stream intervenes, show by sketch how this would be dealt with practically.
2. Sketch and describe two methods of procedure when an obstruction occurs to the continuation of a chain line.
3. Describe how a chain line may be continued across a river and the omitted portion measured.
4. Show by a sketch the special precautions that are necessary in continuing a chain line when it is obstructed by an intervening building.
5. At what distance apart would you place pickets or station poles in poling out a long chain line, and how would you ensure that they were in a straight line?
6. Illustrate by sketches what is meant by gaps and détours in chain lines and some of the methods of overcoming them.

## CHAPTER XI.

Plans and maps—Various systems of projection—Curvature of earth not taken into account in ordinary surveys—Ordnance survey maps—Surveying over hilly ground—Correction for inclination, how made—Instruments for obtaining angle of slope—Indicating hilly ground on maps—Hachures—Contour lines.

**Systems of projection.**—All plans and maps are drawn upon flat surfaces, but they have to represent portions of the earth's surface, which is, roughly speaking, spherical. An attempt to lay a piece of orange peel flat would illustrate the difficulty that arises in representing any large tract of country upon a flat sheet of paper. If a terrestrial globe be examined the lines of longitude will be seen meeting at the poles. If all these lines were cut through and the paper removed, there would result a number of strips with pointed ends, as Fig. 80, which would for all practical purposes lie flat, and would contain the representation of the whole surface with blank spaces between the ends, and the same scale could be applied to any part. Suppose the tapering points, with everything marked upon them, to be widened until the strips were parallel, then the whole of the length and breadth would be covered and the lines of longitude would be parallel, but the scale would be variable, increasing from the centre to the top and bottom. This is known as **Mercator's projection**.

Examining the terrestrial globe again, lines of latitude will be seen as circles, at equal distances apart from the equator to the north and south poles, and therefore varying in diameter, getting very small towards the poles. Looking down upon one of the poles the circles upon that half of the globe will be seen to be concentric, *i.e.* all struck from the pole as a centre, but, owing to the curving of the surface, as the circles get larger they will appear to be closer together,

and the countries near the equator will appear cramped along the lines of longitude although having their proper dimensions in the other direction. If the circles be drawn, not as they appear, but at equal distances apart, then the scale will be uniform along the lines of longitude and enlarged along the circles in proportion to the distance from the pole. This is known as **Polar projection**.

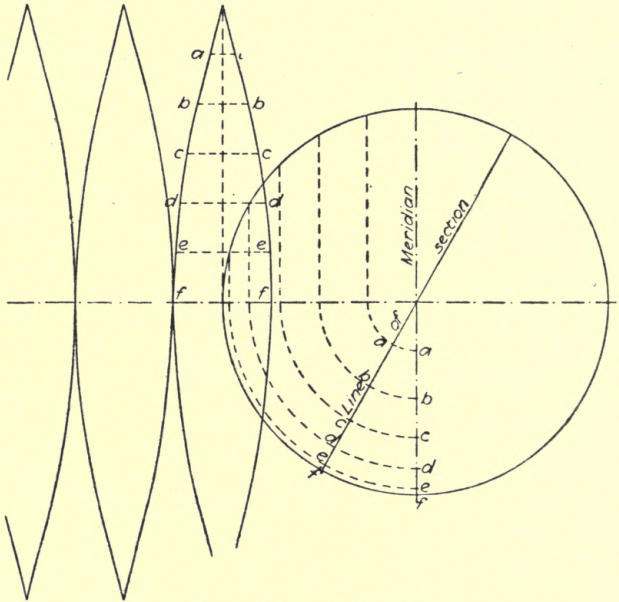

FIG. 80.—Mercator's projection.

There are also *Orthographic*, *Stereographic*, *Gnomonic*, and *Flamsteed's projection* applied to representations of the hemisphere. These may be found described in various works on map projection, but are of no immediate use to the land surveyor.

**Ordnance survey maps.**—In the Ordnance Survey, where a considerable tract of country has to be delineated, the difficulties are not quite so great, but are of the same



kind, and in measuring long base lines and taking the angles between them, spherical trigonometry has to be employed to enable the necessary corrections to be made. In practice the principle adopted is shown in Fig. 81, where the flat surface

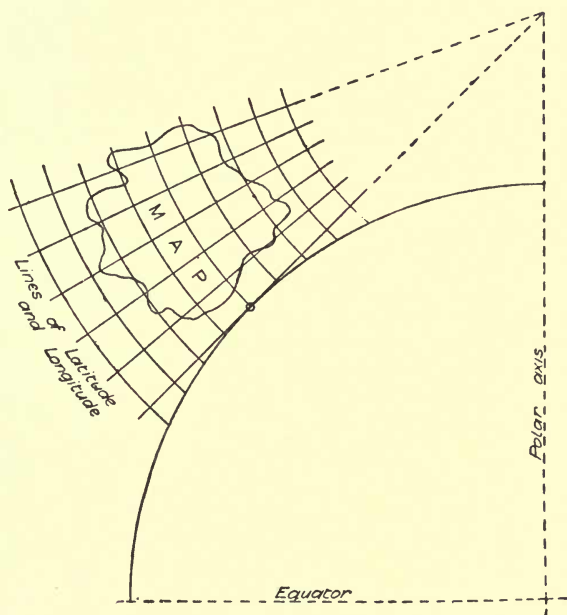

FIG. 81.—Tangential projection.

of the paper is tangential to the globe at its centre point, so that the distortion is reduced to a minimum.

**Surveying over hilly ground.**—When the area is smaller, as in a parish or estate, difficulties due to curvature of the earth are inappreciable, but local curvature due to hilly ground, necessitates the reduction of inclined chain lines to horizontal lengths. If  $ab$ , Fig. 82, represents the slope of the ground or inclination of the chain line,  $ac$  a horizontal line, and  $bc$  a vertical one, then  $ab$  will always be longer than  $ac$ , and as  $ac$  is the length to be put upon the plan, the

measured chain line must have some correction made. But it may be said that if  $ab$  represents the actual surface of the ground, and  $ac$  is the length it is bought and sold by, it would be better to buy hilly ground, because there would be more

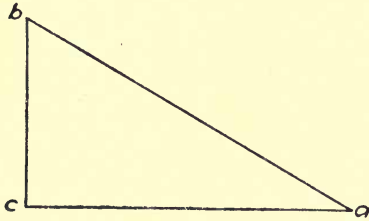

FIG. 82.—Inclination of ground.

for the money. A moment's consideration would show that there would be no increase in the number of houses of a given frontage that could be put upon it. With corn and trees, of course, the growth is vertical—towards the light—so that on any slope the actual direction of the stalk or tree is at right angles to the horizontal. There is a certain natural distance apart for the stalks to grow whatever the slope may be, so that although the surface may be larger on sloping ground, the crop will be regulated by the horizontal area, and the value will not be augmented; in fact, hilly ground is often less valuable, from the extra labour entailed in any operation upon it.

**Corrections for inclination.**—In measuring hilly ground, whether the surveyor is going uphill or downhill, the same correction has to be made, and the practical method of doing this is shown in Fig. 83. Each chain length upon the ground is marked by an arrow, and the chain then pulled forward according to the slope,

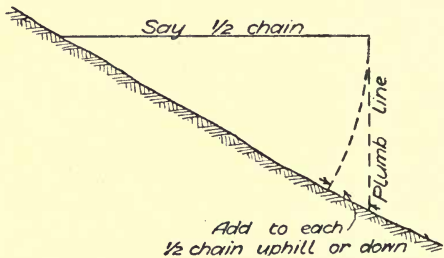

FIG. 83.—Method of allowing for sloping ground in chaining.

and the arrow shifted to the new position, so as to indicate a horizontal chain length. This is better than measuring straight through and then calculating the reduction on the

length to give true horizontal distance. If any offsets occur on the chain it may be pulled forward part of the way according to the position of the offsets, so that all the offsets will be recorded the same as in ordinary chaining.

When the angle of inclination is known the amount of correction may be taken from the following table :

Angle.	Allowance.	Angle.	Allowance.
4 degrees.	$\frac{1}{4}$ link.	14 degrees.	3 links.
6     "	$\frac{1}{2}$ "	16     "	4     "
8     "	1     "	18     "	5     "
10    "	$1\frac{1}{2}$ "	$19\frac{1}{2}$ "	6     "
$11\frac{1}{2}$ "	2     "	20     "	$6\frac{1}{2}$ "
$12\frac{1}{2}$ "	$2\frac{1}{2}$ "		

Trigonometrically the additions = secant - radius.

**Objections to stepping.**—Some of the books and some practical men recommend **stepping** with the chain on inclined ground, as shown in Fig. 84, but it is a very objectionable

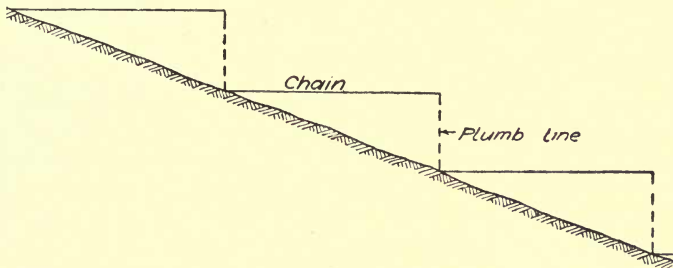

FIG. 84.—“Stepping” with chain.

method. The weight of the chain renders it physically impossible to pull it out straight ; very few men are able to judge when it is horizontal, and the common plan of dropping an arrow to plumb the end is a clumsy termination to an altogether inadequate method. The writer has several times tested the method with parties of students, and frequently the corrected horizontal distances in a length of six or seven chains has come out longer than the measurement on the slope itself. When the method is used, a half length of the chain should be taken, and the end on the low side held up until it

appears to be horizontal, then an arrow should be dropped, ring downwards, to mark the plumb point under the end, the chain then laid down and the difference between this point and the end of chain noted, as in Fig. 83. Twice this difference will be the amount to pull each chain forward in measuring on the slope. This may be tried two or three times to get the allowance as accurate as possible. If the chaining is going to be uphill, Fig. 84 could not be adopted,

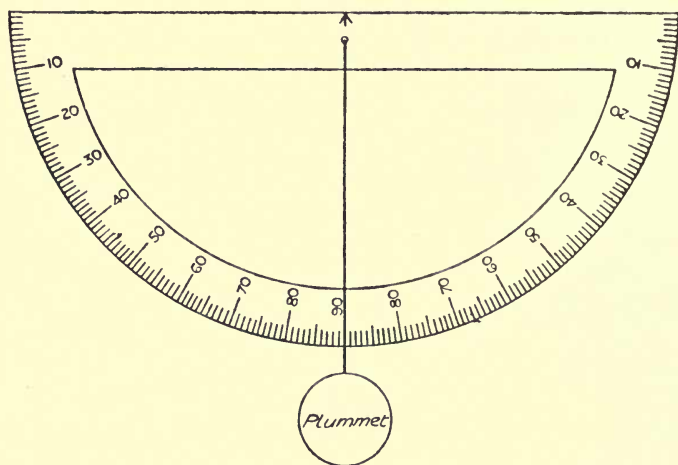

FIG. 85.—Protractor with plummet.

but there is no difficulty in determining the allowance by Fig. 83 before the chaining is commenced.

**Angle of slope measured by instruments.**—The angle of a slope may be taken by instruments, such as a common brass **protractor with a plummet** on a long thread, as Fig. 85, or a **surveyors' card**, as Fig. 86, or by an **Abney's reflecting level**, as Fig. 87.

In using these instruments the surveyor sights the top rail of a fence, or a man's head, or anything at a distance, about the height of the surveyor's eye, as the line of sight will then be practically parallel with the surface of the ground.

The **Abney level** consists of a square tube, sometimes with

a draw-out eyepiece but no lens in it, and sometimes with a small telescope, but neither of these accessories is of much use. There is a mirror placed at an angle of 45 degrees in a draw tube at the other end, and occupying half its width ; a

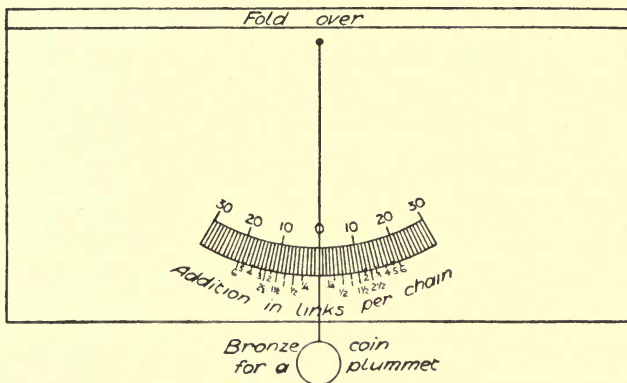

FIG. 86.—Surveyors' card.

horse-hair "wire" is fixed across this draw tube, cutting the central axis and in the same line of sight as a mark cut across the mirror. A small spirit level is attached to a vernier arm which can be rotated by a milled wheel over a divided arc.

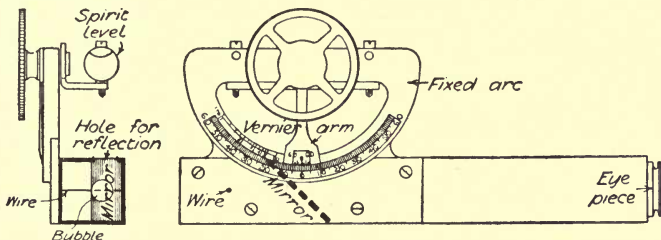

FIG. 87.—Abney's reflecting level.

In sighting to any point cut by the wire, the wheel is turned until the reflection of the bubble is cut centrally by the mark on the mirror, then the vernier is read off.

**How hilly ground is shown on maps.**—To indicate hilly ground on plans there are two principal methods in use; one is by a special sort of shading formed by **hachures**

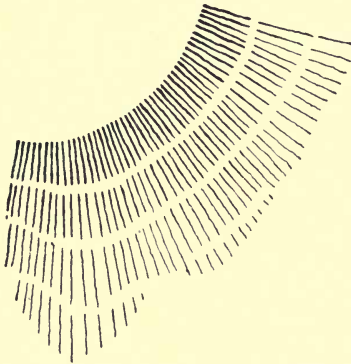

FIG. 88.—Indicating hilly ground on plans.

or strokes put in the direction in which water would flow from any point on the ground, as Fig. 88. They are darkest near the crest of the hill, *i.e.* thicker and closer together; they are also shortest there, and it will be noticed from the diagram that they are all tapering and slightly wavy. Continuous lines would not give the same effect; they require to be broken in order to keep them fairly close together down the hills, and so at each joint,

as it may be called, the lines increase in number. Another way of showing hills, principally used in military surveying, is by putting the lines in the reverse direction, *i.e.* running round the hills, as in Fig. 89, but keeping them thicker and closer upon the steeper ground. In both these methods the right and lower sides of the hills are made rather darker than the other parts, as will be seen on looking at the mountain chains in any good atlas.

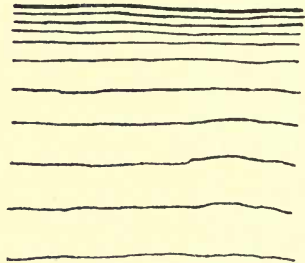

FIG. 89.—Another method, used in military surveying.

Another system which has been known and practised for many years, is now coming into more general use; it is not so pictorial, but admits of greater accuracy and usefulness. The system is known as **contouring** and the lines as **contour lines**. These may be called the outlines of horizontal sections taken at equal vertical distances. They may be 10 to 100 feet apart vertically according to the

nature of the surface, the former, say, in London and the latter in a mountainous country, but the distances will also vary with the scale, the smaller the scale the greater must be the distance apart. In any drainage operations, especially surface drainage, particular attention must be paid to the

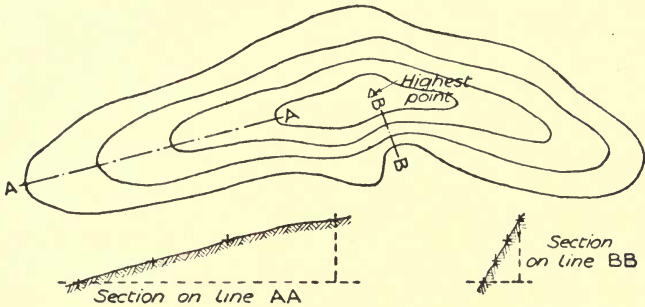

FIG. 90.—Plan of contour lines round a hill.

contour, and advantage taken of the natural surfaces in obtaining the required fall at a nearly uniform depth.

Fig. 90 shows a plan of four contour lines round a hill, which may be looked upon as coast lines formed by water rising to different levels. When the contours are further apart, as across line AA, it is evident that the slope is flat, as shown by the section AA; and when they are closer, as at

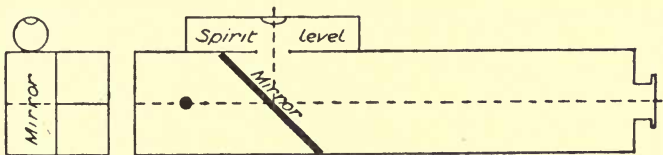

FIG. 91.—Hand reflecting level.

BB, the slope is steeper, as shown in section BB. The highest point on a contoured surface is generally marked by a small triangle.

Contour lines are set out in various ways according to the circumstances of each case. A good method for a limited

area is shown in Fig. 92. Poles are set as shown by the small circles. Levelling from a bench mark in the neighbourhood by means of a dumpy level and staff, a point is fixed between one of the outer poles and the centre one, as at *a*, at the height of a given number of feet above Ordnance datum. Another point, *b*, is fixed in the same way at the required difference of level between the contours, and afterwards point *c*, and so on according to the height. The same series of operations takes place on each of the radial lines, giving the points marked by small crosses. Then an

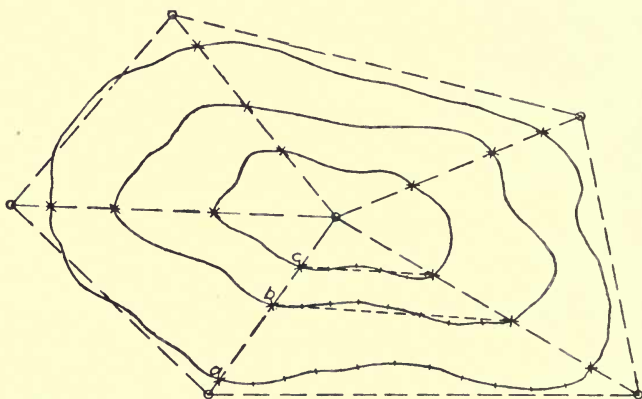

FIG. 92.—Method of setting out contour lines.

assistant holds the levelling staff on point *a*, and the surveyor stands near with a common hand reflecting level, Fig. 91. He observes what height the wire cuts on the staff, and then directs the assistant to walk along the probable line of contour, and signals him up or down until the level gives the same reading. This is repeated to give a series of positions shown by the short lines across the contours, working half way from each of the radial lines. Then all the lines are chained and the contour points taken by offsets. Contours frequently form two or more closed rings within single larger rings. This occurs when more than one hill rises out of the earlier slopes, and there may be a series of contours within these inner rings if the hills rise to any considerable extent.



QUESTIONS ON CHAPTER XI.

1. How can a map which is flat represent part of the earth's surface, which is a portion of a sphere? Describe one method of overcoming the difficulty.
2. Describe a method of chaining on hilly ground to ensure true horizontal measurements.
3. With a slope of 1 in 10 state what will be the correction per chain for length of line, and whether it will be added or deducted. (Ans. :  $\frac{1}{2}$  link, added).
4. Show by sketch what is meant by "stepping with the chain," and describe the precautions necessary to be taken.
5. Sketch and describe the use of a hand instrument for ascertaining the slope of ground.
6. Define a contour line. Give a small specimen of hill shading.

## CHAPTER XII.

Field notes for survey of small farm—Sketch of chain lines—Secondary lines not falling on previous station—Plotting notes and preparation of survey plan.

**Survey of a small farm.**—The accompanying plan and field notes are for the survey of a farm near Hampstead, made

some years ago when the land was more open, by Mr. J. H. Castle, a celebrated land surveyor. Plotted to a scale of 1 chain to 1 inch on “double elephant” paper (40 in. by 27 in.), it will occupy a net space of 32 in. by 22 in., or on “imperial” paper (30 in. by 22 in.) to a scale of 2 chains to 1 inch it will occupy a net space of 16 in. by 11 in.

True north should be at the head of the paper, each field should be numbered, and the areas tabulated in one corner of the plan. Fig. 93 shows a rough sketch plan of the chain lines which will be of considerable use in plotting the notes. The magnetic variation was  $20^{\circ}$  W., and allowance must be made for this in plotting.

Each page of the field-book is here shown separately. It

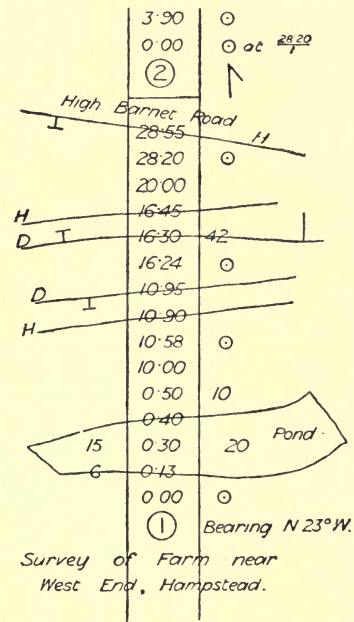

is sometimes difficult to get a line to fall exactly on a previous

# SURVEY OF FARM NEAR WEST END HAMPSHIRE

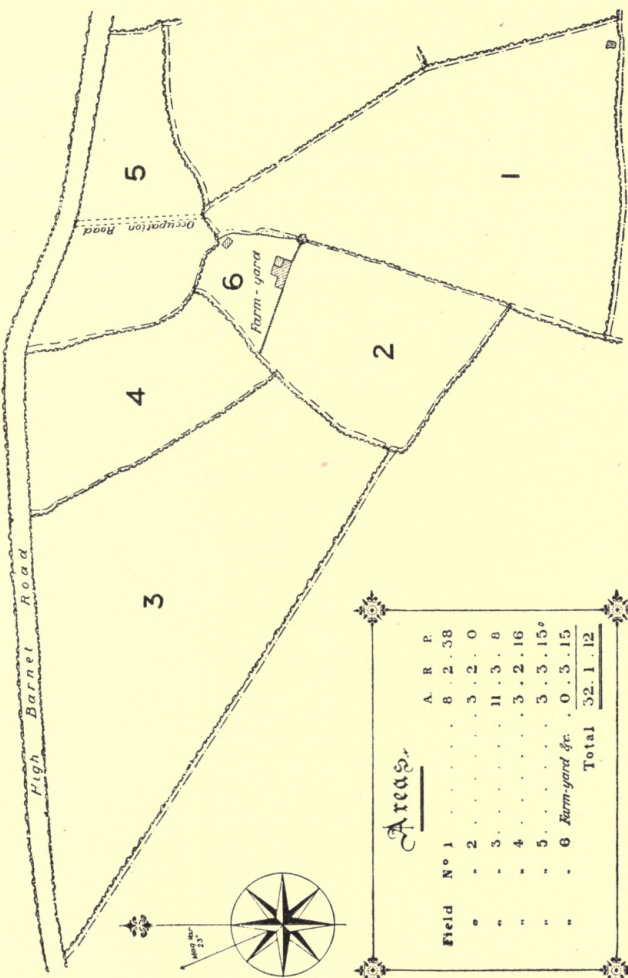

### Areas

Field No 1	A	R	P
1	8	2	38
2	3	2	0
3	11	3	8
4	3	2	16
5	3	3	15
6 Farm-yard &c.	0	3	15
Total	32	1	12

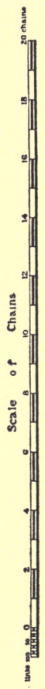

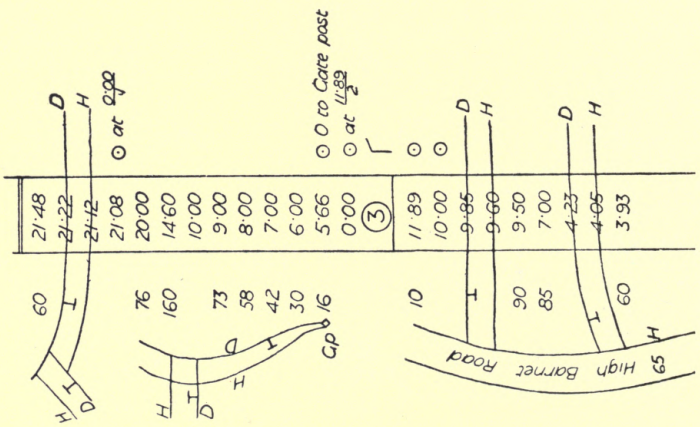
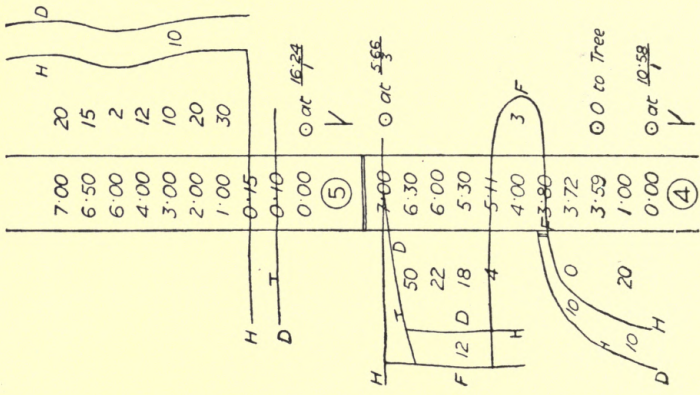

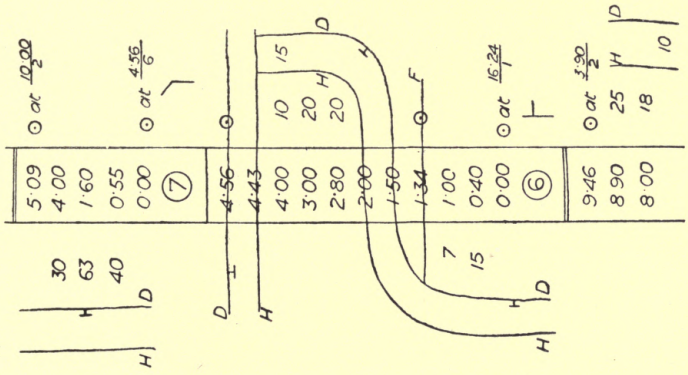
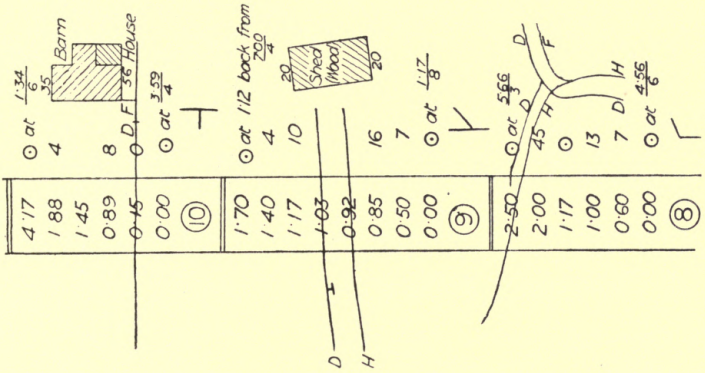

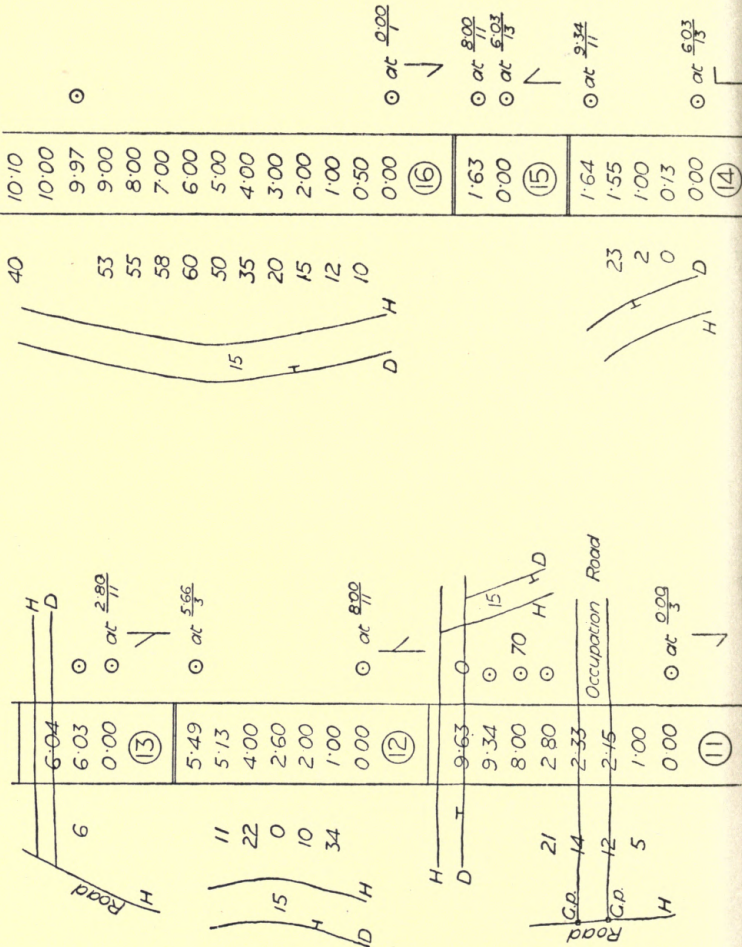

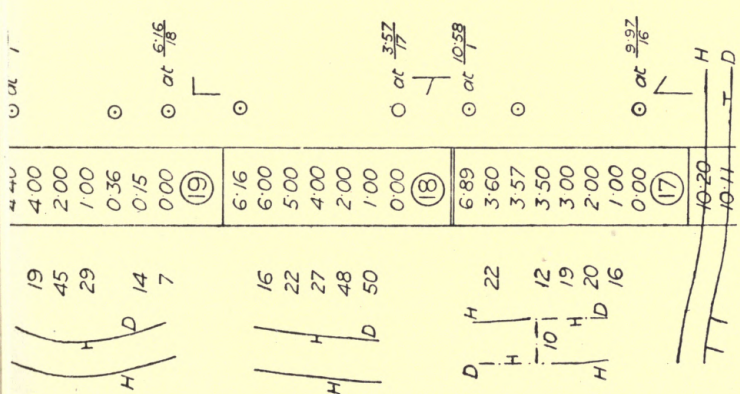
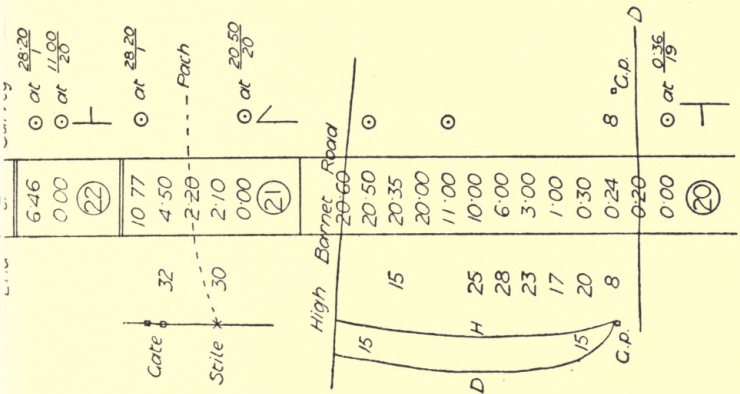

station, the junction is then recorded as in the case of 1·70 on line 9 in this survey, which is located by being described as 1·12 back from 7·00 on 4. This difficulty often arises from the 6-ft. or 10-link pickets, or station poles, being too short to be seen far over rough ground, and although long poles are more inconvenient to carry about owing to their length and weight, they are found very useful in a large survey. A flag on the

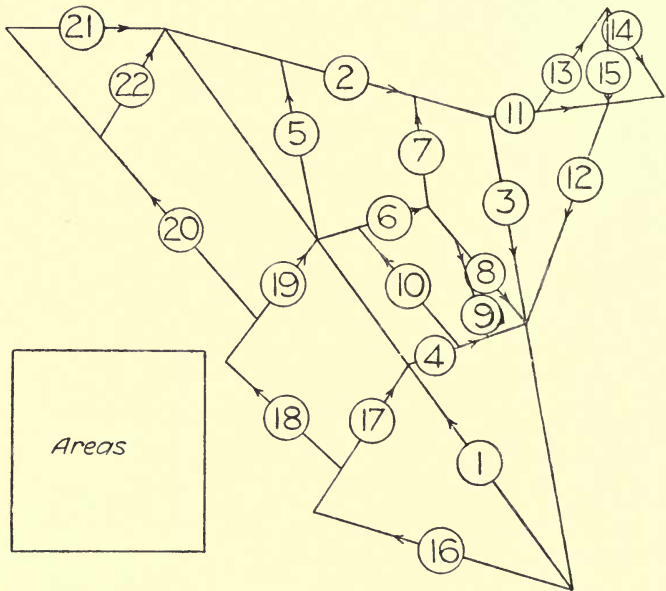

FIG. 93.—Chain lines for survey.

top of the pole, even although it is not more than 12 in. square, by its fluttering in the wind enables the station to be seen from a very long distance by the naked eye.

In a survey made by the writer at Epping Lower Forest, one of the lines was 26 chains long, and yet the small flag on a 6-ft. pole could be seen by the naked eye, which was rather good, considering the proximity of London smoke.



## QUESTIONS ON CHAPTER XII.

1. What are the advantages of making a sketch plan of the principal lines of a survey in the field-book before commencing the chaining?
2. What considerations would guide you in fixing the direction of the base line of a survey?
3. Describe how the bearing of a line may be taken in the absence of a compass.
4. What degree of accuracy in measurement is necessary in order that no error should exceed the thickness of a line on a scale of 1 chain to 1 inch? (**Ans. : To 1 link.**)
5. A boxwood scale is marked on one edge "chains," and on the other "88," and it is found by trial that 8 chains measure 6 inches. Explain the proportion and use of the scale.
6. Show by a sketch how you would connect two detached portions of an estate by chain lines so as to plot them in their true relative position on the same map.

## CHAPTER XIII.

Instructions of The Copyhold, Inclosure and Tithe Commission for the preparation of "First Class Plans"—Regulations for testing plans—Charges for surveys—Errors in chaining.

**First Class Plans.**—Very little remains to be said under the head of Land Surveying. The Copyhold, Enclosure and Tithe Commission published instructions some years ago (Dec. 1, 1861) for the preparation of **First Class Plans** which may be usefully studied at the present time. They represent the best procedure in official work, and are given below by permission of the Board of Agriculture :

### DESCRIPTION OF PLAN REQUIRED.

The Plan is to be made on good drawing paper previously mounted on linen, and is required to represent, in their true relative positions, the several objects which occupy the surface of the ground, such as railways, roads, rivers, lakes, ponds, canals, streams, drains, parks, woods, fences, houses and other buildings, bridges, etc. ; also the boundaries of counties and their various subdivisions, such as ridings, lathes, wapentakes, rapes, hundreds, parishes, townships, etc., and all the details usually given in estate surveys. Plates showing the boundary and other characteristics to be used, may be obtained by application to the Commissioners.

The ordinary usage in other respects is to be observed, of placing the north towards the top of the Plan, writing the name of the parish and county and other necessary information, as a title, the name and address of the surveyor, the date of performance, the scale, and the total contents. And when a parish is mapped in two or more distinct parts, a notice to that effect must be added to the title.

The Plan is to be drawn to the scale of three chains to one inch in rural parishes or districts, and two chains or one chain to an inch in towns. With a view to the easy determination at any time of the contraction of the paper, a long single-line scale, graduated to thousands, is to be drawn at the foot of the plan when the plotting is commenced.

The lines of construction or main lines should, wherever practicable, be laid out before they are chained, and be disposed in the form of triangles, each triangle having a proper proof line measured within it from one of the angles to the opposite side.

All lines measured over hilly ground are to be reduced to the horizontal plane.

The entries in the field-books are to be made *with ink in the field*, and the chained lines are to be numbered consecutively throughout the books.

The name of the person by whom the survey is actually made is to be entered at the beginning of each book, and the date is to be noted at the commencement of each day's work.

When alterations are made in the field-books, an explanation of the cause of the alteration is to be entered at the same time, and erasures in the field-books can on no account be allowed.

The chained lines are all to be drawn upon the Plan in red ink, and marked with a reference to the number of the line in the field-books, or to the page of the book in which the notes of the measurement are entered;—thus, L 1, L 2, L 3, etc., if referring to the lines, or P 1, P 2, P 3, etc., when referring to the pages. And when several field-books are used, each book should have a distinctive letter assigned to it, which may be added to the reference upon the plan after the number referring to the line or page;—thus, L 1, A; P 1, B; etc. The lengths of the construction or main lines should also be added to their respective reference numbers.

Each separate parcel of land is to be numbered upon the Plan, the numbers following in succession from No. 1 to the highest number required. These numbers are to correspond with those given in the Reference Book.

The boundaries or limits of all land and parcels of land are to be treated separately, are to be marked on the Plan, whether they are defined by fences or not; and where no boundary fences exist, the exact limits are to be shown by a dotted line.

The Quantities are not to be written upon the Plan, but in the Reference Book only.

The Quantities in the Reference Book are to be arranged in the consecutive order of their reference numbers, and figures are invariably to be used for the reference.

When the quantity of two or more *contiguous* parcels of land is given in one sum, the reference number must be repeated on each parcel, or the parcels must be connected by a brace, as in the annexed sketch (Fig. 94), where it is shown by the brace (∫) that four parcels of land, the house, and the pond are all included in the quantity assigned to No. 47.

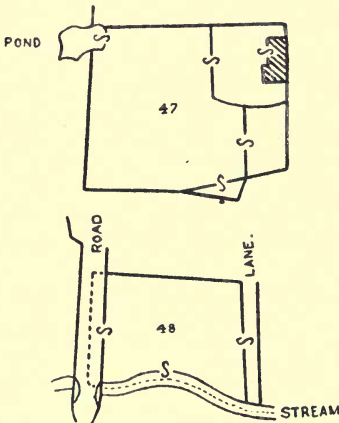

FIG. 94.—Method of indicating parcels of land taken in one area.

It is essential that the accuracy of the Plan, when completed, should be such that the measurement on the Plan of the inclosures thereon represented should correspond with the quantities assigned to them in the Book of Reference, and such also as to bear the test of comparison with any proof lines which the Commissioners may desire to have measured upon the ground.

The *working* Plan, prepared as above, together with the *original* field-books and Reference Books, must be sent to the office of the Commission for examination, otherwise the accuracy of the work can only be proved by the measurement of test-lines upon the ground.

Where the whole breadth, or any portion of a road, stream, etc., is included with the adjoining field, the brace must also be used; and where only part of the road, stream, etc., is included, the exact limit to which the quantity applies must be marked with a dotted line on the Plan.— See No. 48 in the annexed sketch (Fig. 94), of which the quantity is thus shown to include the whole breadth of the lane, half the road, and half the stream.

It is essential that the accuracy of the Plan, when completed, should be such that

The Commissioners will not pledge themselves to seal a Plan to which any of the following objections apply, without testing it upon the ground :

1. Where there is any reason to distrust the authenticity or integrity of the survey.
2. Where the means afforded are insufficient to prove the accuracy of the work *in all its details*.
3. Where the Plan does not agree with the field-books.
4. Where the field-books have been kept *in common or metallic pencil*.
5. Where erasures have been made in the field-books.
6. Where alterations have been made in the field-books without a satisfactory explanation being afforded.
7. Where the offsets *exceed* a chain in length.

#### REGULATIONS FOR TESTING PLANS UPON THE GROUND.

The Commissioners will require to appoint the Surveyor to be employed, and that a sum of money sufficient to cover the expenses should be lodged in their hands before the testing is commenced.

The lines which the Commissioners will require to have measured on the ground, for testing the accuracy of the Plan, are three lines in the form of a well-shaped triangle, with a proof line from one of the angles to the opposite side.

In measuring the testing lines, all intersections of fences are to be noted, and offsets taken within the ordinary limits of a chain's length.

Distances, measured along the fences joined, are to be given to all junctions of fences which fall within two chains of the test lines.

The fields in which the angular points of the triangle occur are to be wholly surveyed, or enough of their boundaries ascertained to determine precisely the position of those points on the Plan.

The entries in the field-books are to be made with ink in the field, and any alterations which require to be made in them are to be attested by the initials of the surveyor. An explanation of the cause of the alteration is also to be entered.

A projection of the testing lines on the scale of the original

Plan is to be sent with the field-notes to the office of the Commissioners.

The cost of testing on the ground will not, as a general rule, exceed £15 for a parish or district under 3000 acres; and for a parish of larger size will be at the rate of £5 per thousand acres, not including travelling expenses."

Generally speaking, in ordinary chain surveys an error of 1 perch per acre is allowable, or say 1 link in 10 chains, but in tithe or parish surveying perfect accuracy is expected; or, in other words, no error must be so great that it is possible to be detected. In railway surveying for Parliamentary Plans, only a generally close approximation to accuracy is required. A scale of 1 chain to 1 inch allows a difference of 3 inches upon the ground to be detected upon the plan, and this will give some idea of the accuracy in plotting which is attainable. Usill says that "40 acres per day is good average surveying," but this will obviously depend upon the nature of the land and whether there are many buildings and small enclosures.

**Charge for surveys.**—The charge for surveys may be assumed to be approximately as follows:

For surveys of country estates: With map showing external boundary and gross area—3 guineas, plus 1s. per acre for first 100 acres, and 9d. per acre for remainder. With map showing boundary and area of each farm—4 guineas, plus 1s. 6d. per acre for first 100 acres, and 1s. per acre for remainder. With map showing fields, buildings, etc., with area of each inclosure—5 guineas, plus 2s. per acre for first 100 acres, and 1s. 6d. per acre for remainder. Copies of the map:

Scale $\frac{1}{3}$ in. to 1 chain,	-	-	-	1d. per acre.
„ $\frac{1}{2}$ „ to 1 „	-	-	-	2d. „
„ 1 „ to 1 „	-	-	-	3d. „

Reductions or enlargements one-half more, but no charge less than half-a-guinea. Elaborate plans according to time. Surveys of building plots by special arrangement, from 3 guineas. Travelling and hotel expenses in addition to above charges.

Town surveys by special arrangement.

**Note on errors in chaining.**—Capt. J. E. E. Craster (1911) had 208 lines chained by 40 surveyors across rough

country in all weathers. The correct length of each line was determined by triangulation unknown to the surveyors.

A few large errors in booking occurred, and other considerable errors were unaccounted for. Rejecting all lines with errors of over 50 links, there only remained 196 lines giving 92 positive and 104 negative errors. The lines were grouped for analysis as follows ;

No. of Lines.	Length in Chains.	Mean Error in Links.
27	70-80	10·21
32	80-90	9·5
23	90-100	10·8
34	100-110	11·53
21	110-120	13·8
30	120-130	13·6

General average error, say 1·16 links in 10 chains.

### QUESTIONS ON CHAPTER XIII.

1. Name the usual scales for survey plans and the conditions under which they are used.
2. Why are lines chained on sloping ground reduced to horizontal measurement ?
3. Describe the method of testing the survey plan of a parish.
4. What percentage will an error in area of 1 perch per acre be ?  
(Ans. :  $\frac{5}{8}$  per cent.)
5. What degree of accuracy is required in Parliamentary Plans ?
6. What would be the approximate cost of making a survey of 250 acres in a rural district, and supplying a map showing fields, buildings, etc., with their areas ? (Ans. : £26 10s.)

## CHAPTER XIV.

Traversing with chain—Traversing with prismatic compass—Reducing bearings—Circumferentor—Definition of terms used in traversing.

**Traversing with chain.**—Traversing is the name given to a method of surveying by which, without covering the whole area with a network of triangles, a boundary or route, as of a

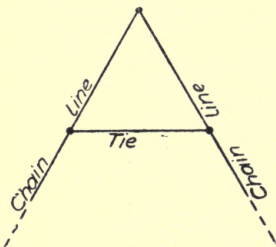

FIG. 95.

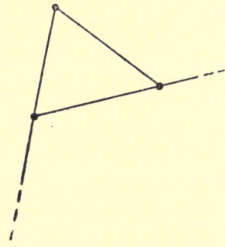

FIG. 96.

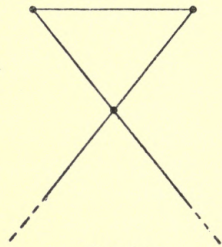

FIG. 97.

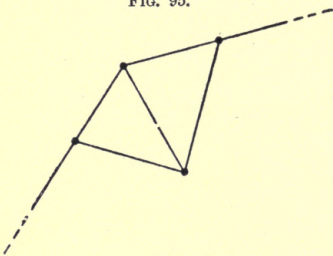

FIG. 98.

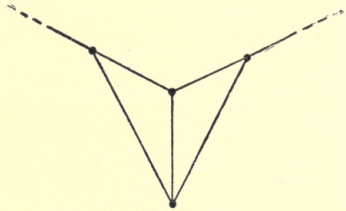

FIG. 99.

FIGS. 95 to 99.—Tie lines in traversing.

road or river, can be surveyed in the course of passing along it. This may be done roughly with the chain only, the end of each line being tied to the next by a small measured triangle, or two triangles, variously formed according to the



angle between the lines as in Figs. 95 to 99, and so enabling any number of lines to be plotted without forming them into the ordinary large triangles. The lines may be ten or twenty chains long if necessary, while the sides of the triangles will not be more than one or two chains long.

In plotting the survey it will make for accuracy if the triangles are set off to twice the scale of the lines, but it is quite evident that this method, although very simple, is not

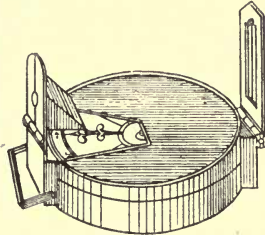

FIG. 100.—General view of prismatic compass.

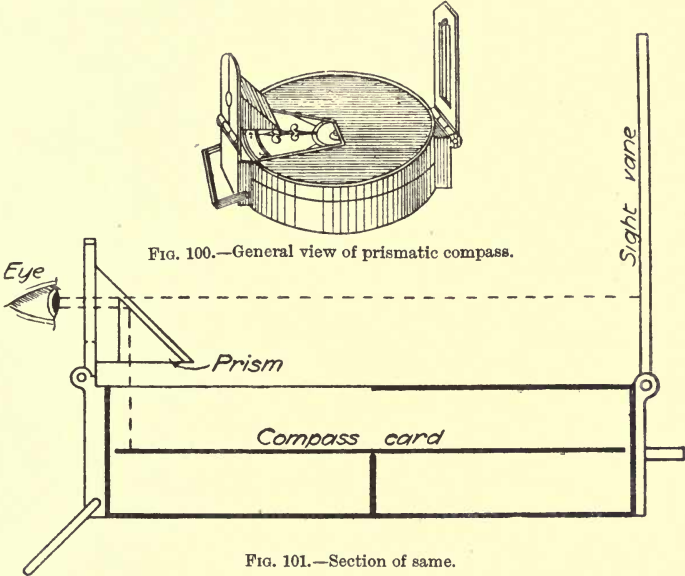

FIG. 101.—Section of same.

very precise, as an error at any point of the survey affects the whole of the remainder, and there is practically no check upon the work. With proper care it may be useful in certain circumstances, its chief advantage being that with no more knowledge than that possessed by an ordinary chainman a survey of considerable extent may be made with some approximation to accuracy, without any instruments beyond the chain and station poles. Two independent surveys at considerable distance apart may be connected upon the same principle ; all

that is requisite is to run a chain line between them and tie the ends to a line in each survey by one or other of the little triangles.

**Traversing with prismatic compass.**—By the use of the **prismatic compass** (Fig. 100 general view, Fig. 101 section and Fig. 102 plan) greater accuracy may be obtained, as, although the instrument is not very trustworthy, the error is practically confined to the individual lines upon which it is

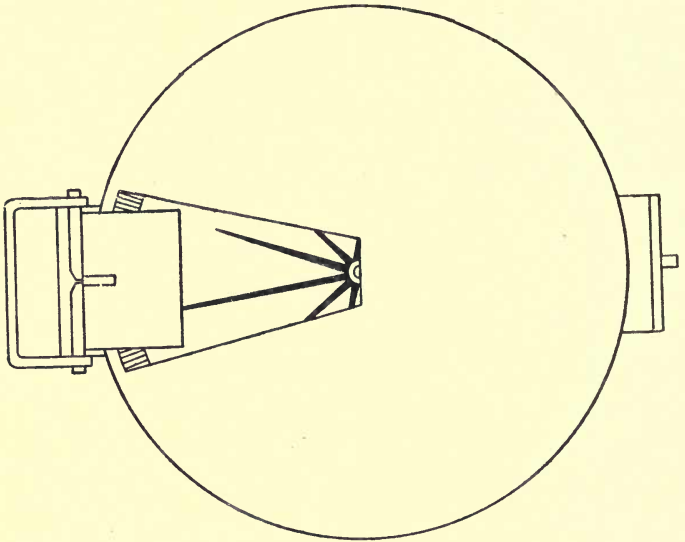

FIG. 102.—Plan of prismatic compass.

used. Its construction combines a reflecting prism with a magnetic compass. It is marked in the reverse way to what it would be if the card were observed by direct vision; for example, when the needle is pointing north the eye is looking at the south end of the card and the zero or north must be indicated there. For the same reason the divisions appear to be numbered backwards. The lines are chained in the ordinary manner, but instead of tying their junctions with triangles, the direction of each line is taken with regard to the magnetic meridian, or, in common language, its “bearing” is taken.

There is still the liability to error in measuring the length of the lines from omitting a chain length, but if a sufficient distance is sighted there will not be any great error of direction.

A short staff is useful to rest the compass on if the hand is at all unsteady, and if there are large water mains under the ground, or the observation is taken in proximity to iron railing, the compass may be affected. In compass surveys it may be stated that the allowable error is one link in five

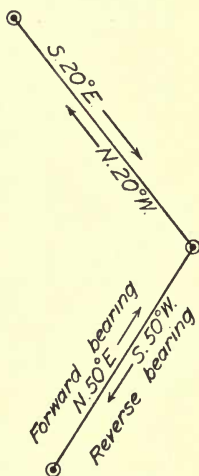

FIG. 103.—Forward and reverse bearing of line.

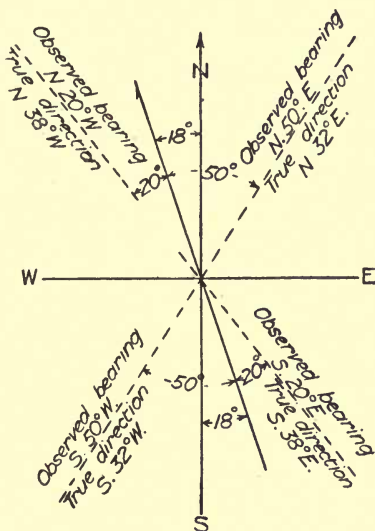

FIG. 104.—True direction of lines.

chains. All the stations may be known by the number of the line which commences at that station. A circular protractor will be found convenient to use for the plotting. The reverse bearing should be taken on every line as a check upon the forward bearing; see Fig. 103.

**Reducing the bearings.**—In reducing the bearing of any given line to its true direction, it is well to make a sketch of a north point with the magnetic variation upon it, as it will then be seen by inspection whether the magnetic variation is to be added or subtracted from the given bearing, and how many

right angles have to be subtracted to get the true bearing (Fig. 104).

Compass surveys are usually confined to rough preliminary work, or to filling in the details of a large survey after the main points have been fixed by more accurate means. The survey should be checked by taking frequent bearings to surrounding objects that can be observed from two or more stations.

A recent form of the surveyors' compass made by Messrs. F. Barker & Son, Camberwell Road, London, to take the place of a prismatic compass, is shown in Fig. 105. This compass is a

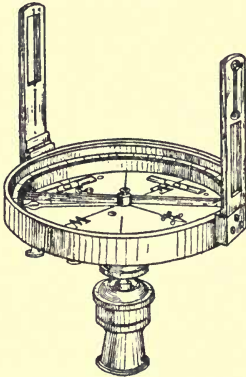

FIG. 105.—Surveyors' compass.

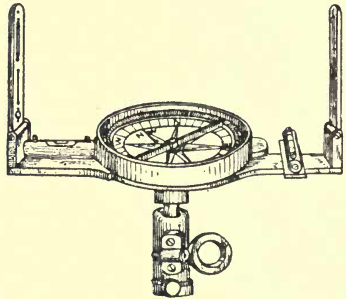

FIG. 106.—Circumferentor.

good instrument for approximate work, and, being made very substantial in every way, will stand the rough usage often happening when using this class of compass. The folding sights are made with hair and slit vane on each; this gives the advantage of taking a reverse sight when in alignment. The sight vanes attached to the outer limb of the compass are made to revolve around its circumference, and a vernier also is attached. The compass is fitted with two spirit levels, bar needle, jewelled centre and stop, and is used with a ball-and-socket head "Jacob-Staff."

A **circumferentor** (Fig. 106) is a more elaborate compass with sights to it, which can be used for the same class of work. It is also called a *miner's dial*, as it is frequently used underground for surveying mines, but is not in any way to be

compared with a theodolite for accuracy. There are certain terms used in connection with compass surveys that it will be well to explain.

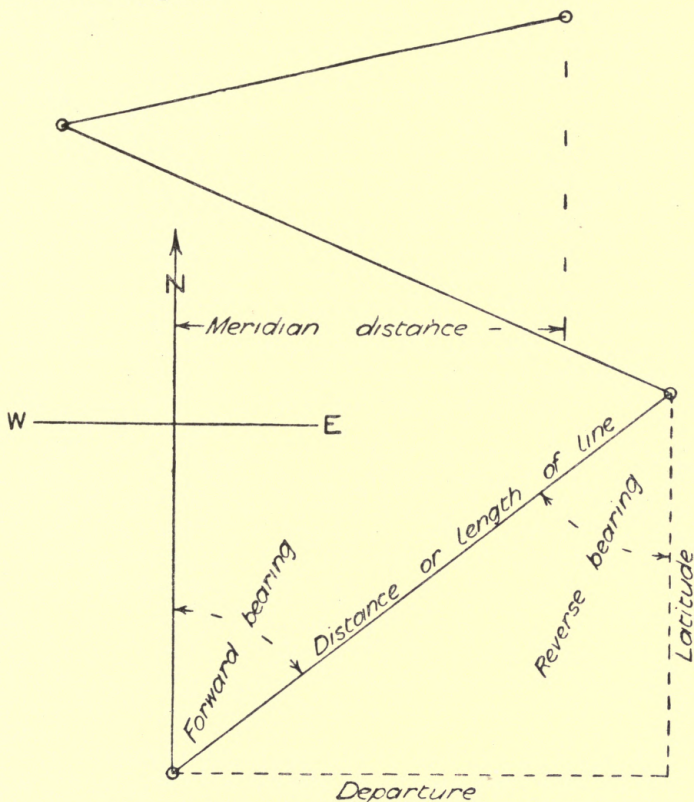

FIG. 107.—Illustration of terms used in compass traversing.

**Terms used in traversing.**—Meridian lines are lines lying due north and south, and all meridian lines are assumed to be parallel.

The bearing of a line is the angle made by it with a meridian line, and is measured either by degrees up to  $360^\circ$  East of

North, or by degrees up to  $90^\circ$  E. or W. of N. or S., according to the mode in which the compass card is divided.

The reverse bearing is the bearing taken at the end of a

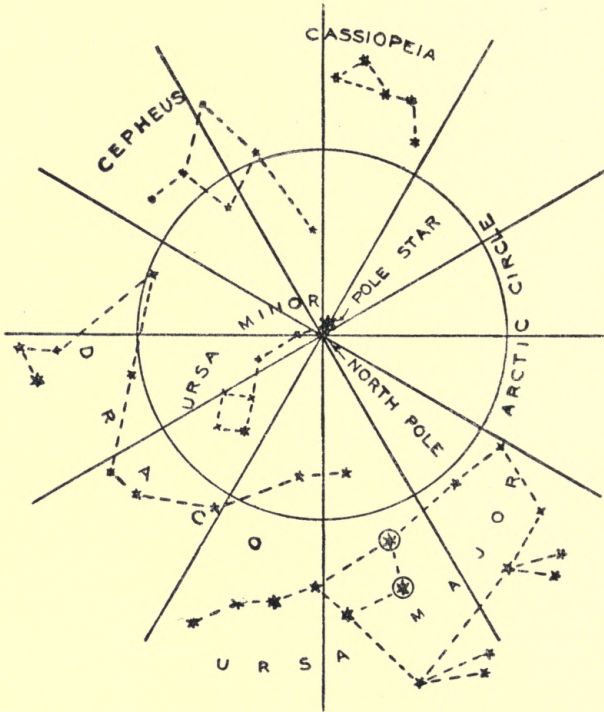

☉ THESE STARS IN URSA MAJOR  
ARE KNOWN AS THE POINTERS

FIG. 108.—Constellations round the pole star.

line instead of the commencement, and will differ from the latter by  $180^\circ$ .

The difference of latitude or *Northing and Southing* is the distance the end of the line is further north or south than the beginning.

The difference of longitude or *Departure* is the distance the end of the line is east or west from the beginning.

The **meridian distance** of any station is the distance east or west from some previous fixed point, such as the first station, and is equal to the difference between the sums of the eastings and westings, being actually east or west from the fixed point as the total of one or the other is greater.

These terms are illustrated in Fig. 107.

Maps are generally made on rectangular pieces of paper, and so the positions of points on it came naturally to be spoken of in reference to the length and breadth of the map. Also, that part of the world best known to the Romans lay along the coasts of the Mediterranean Sea, so that the length of the map lay from west to east, its breadth from north to south. Hence distances measured eastward or westward were *longitudes* (lengths), distances measured northwards and southwards were called *latitudes* (breadths). This method of indicating the positions of places by means of longitude and latitude, made use of by geographers, has been extended to geometry and land surveying. (Sang.)

The latitude of any place is found approximately by taking the angle of elevation of the pole star, when the angle equals the latitude. The constellations round the pole star are shown in Fig. 108, and as the pole star rotates round the pole it is clear that there are only two points in its course that will give an exactly accurate result.

### EXAMPLES.

The following examples are given for practice in reducing bearings. A sketch should be made in each case to help the work.

1. Given AB, S.  $86^{\circ} 23'$  E., variation  $23^{\circ}$  W., what is the true bearing? (Ans.: N.  $70^{\circ} 37'$  E.)

2. Given reverse bearing N.  $5^{\circ} 17'$  E., variation  $21^{\circ} 30'$  W., what is the true forward bearing? (Ans.: S.  $16^{\circ} 13'$  E.)

3. Given AB making an angle of N.  $237^{\circ}$  E., variation  $18^{\circ}$  W., what is the true bearing? (Ans.: S.  $39^{\circ}$  W.)

4. Given bearing of 1st line N.  $16^{\circ}$  W., and 2nd line N.  $57^{\circ}$  E., variation  $20^{\circ}$  W., what is the angle between them? (Ans.:  $107^{\circ}$ .)

5. Required the difference of latitude and departure of a line which bears S.  $16^{\circ} 30'$  E., and is 3.47 long. (Ans.: Diff. lat.  $3^{\circ} 33'$  S., diff. dep.  $0^{\circ} 99'$  E.)

6. Given a line bearing N.  $13^{\circ} 30'$  W. and 6.10 long., find the latitude and departure. (Ans.: Lat.  $5^{\circ} 93'$  N., dep.  $1^{\circ} 42'$  W.)

7. What are the latitude and the departure of a line bearing N.  $41^{\circ} 9'$  E., and 4.47 long.? (Ans.: Lat.  $3^{\circ} 37'$  N., dep.  $2^{\circ} 94'$  E.)

8. A line bears N.  $22^{\circ} 45'$  W., and is 27.62 long.; required its latitude and departure. (Ans.: Lat.  $25^{\circ} 47'$  N., dep.  $19^{\circ} 68'$  W.)

#### QUESTIONS ON CHAPTER XIV.

1. Explain by sketches what is meant by traversing with a chain, and state why the method cannot be relied upon for accuracy.

2. Make a sectional sketch of a prismatic compass, and explain why the north end is marked 180.

3. What precautions should be taken in the use of a prismatic compass in a survey?

4. Explain the terms "meridian line," "bearing," "reverse bearing," and "meridian distance."

5. Explain how a point in a survey can be located in reference to the starting point.

6. Make an approximate sketch showing the pole star and the surrounding constellations.



## CHAPTER XV.

Examples of open and closed traverse—Reducing to a single meridian—  
Tables of sines and cosines—Traverse tables—Plotting traverse  
surveys.

**Open and closed traverses.**—An **open traverse** is one where several lines are taken, which, when plotted, make an open figure.

A **closed traverse** is one making a closed figure, or a survey which is completed upon arrival at the point from which it started.

Although the plotting may be done very carefully with a vernier protractor, there is much risk of error, and to avoid this risk, the whole of the traverse may be **reduced to a single meridian**. That is, a north and south line may be drawn through the first station, and all succeeding stations may be calculated as offset points by rectangular co-ordinates, the distances being found by a table of sines and cosines or by traverse tables. In a closed traverse the sum of each set of ordinates should equal zero.

**Sines and cosines.**—A table of sines and cosines is generally given in books of mathematical tables,\* of which that on page 106 is a sufficient extract to show the construction and method of use.

In using a table of sines and cosines for rough work, only the first three figures need be used, increasing the last figure by unity when the fourth figure is 5 or higher, then multiply by the length of the line. It should be noticed that the figures given are all decimals. The columns headed “Diff.” show the difference between the value of one entry and the next, so that a proportional amount may be added for the seconds in the bearing, viz.  $\text{Diff.} \times \frac{\text{seconds}}{60} = \text{quantity to be added.}$

\* See the author's *Practical Trigonometry* (Whittaker & Co., 2s. 6d. net), or for a fuller set of tables, *Chambers' Mathematical Tables*.

## TABLE OF NATURAL SINES AND COSINES.

## NATURAL SINES.

'	30°	Diff.	31°	Diff.	*	34°	Diff.	'
0	5000000	2519	5150381	2493	*	5591929	2411	60
1	5002519	2518	5152874	2493	*	5594340	2411	59
2	5005037	2519	5155367	2492	*	5596751	2411	58
*	*	*	*	*	*	*	*	*
58	5145393	2494	5294258	2468	*	5730998	2383	2
59	5147887	2494	5296726	2467	*	5733381	2383	1
60	5150381	2493	5299193	2466	*	5735764	2383	0
'	59°	Diff.	58°	Diff.	*	55°	Diff.	'

## NATURAL COSINES.

**Traverse tables.**—Traverse tables are given in some of the larger works on surveying, of which the following extract will be sufficient to show the construction and use :

## TRAVERSE TABLES.

## DISTANCE IN CHAINS, ETC.

Deg. and Min.	1		2		3		4		*	9		10		Deg. and Min.
	Lat.	Dep.	Lat.	Dep.	Lat.	Dep.	Lat.	Dep.	Lat.	Dep.	Lat.	Dep.		
24°	·914	·407	1·83	·813	2·74	1·22	3·65	1·63	*	8·22	3·66	9·14	4·07	66°
3	·913	·408	1·83	·815	2·74	1·22	3·65	1·63	*	8·22	3·67	9·13	4·08	57
6	·913	·408	1·83	·817	2·74	1·22	3·65	1·63	*	8·22	3·67	9·13	4·08	54
9	·912	·409	1·82	·818	2·74	1·23	3·65	1·64	*	8·21	3·68	9·12	4·09	51

In using traverse tables only addition is required instead of multiplication, but be careful to notice that between 45° and 90° the figures for latitude and departure are reversed as marked at the bottom of each page and read upwards.

10.62	⊙
(5)	N. 5° W.
6.15	⊙
(4)	N. 44° E.
8.73	⊙
(3)	N. 15° E.
9.24	⊙
(2)	N. 17° W.
4.56	⊙
(1)	N. 30° W.
Open traverse by Compass Mag Var 18° W	

FIG. 109.—Field notes for open traverse.

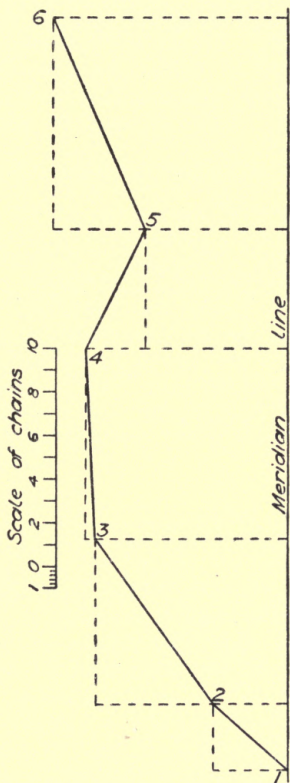

FIG. 110.—Plotting for same.

**Plotting traverse surveys.**—The field notes above, without offsets (Fig. 109), give the lines of an open traverse, with their bearings taken from an ordinary pocket compass, so that they are stated in degrees east or west of north or

south. The plotting may be done to a scale of 5 chains to 1 inch.

In order to carry out the plotting successfully it will be necessary to reduce the bearings, and the proper way of doing this is shown in the accompanying table. The reduced bearing being obtained by sketching a north point, as shown in Fig. 104 in the last chapter, the co-ordinates will be obtained by calculation from the reduced bearings. With this table the plotting may be done in various ways:

- (1) Each line may be plotted from the length given in

*REDUCTION OF OPEN TRAVERSE TO A SINGLE MERIDIAN*

Survey of \_\_\_\_\_ Date \_\_\_\_\_ Mag. Var. 18° W

Station or line	Observed bearing	Distance	Reduced bearings	Consecutive Co-ordinates		Independent Co-ordinates	
				Lat. or cos.	Dep. or sin.	Latitude	Departure
1	N 30° W	4.56	N 48° W	3.0512 N	3.3887 W	3.0512 N	3.3887 W
2	N 17° W	9.24	N 35° W	7.5668 N	5.2979 W	10.6180 N	8.6866 W
3	N 15° E	8.73	N 3° W	8.7180 N	0.4569 W	19.3360 N	9.1435 W
4	N 44° E	6.15	N 26° E	5.5248 N	2.6957 E	24.8608 N	6.4478 W
5	N 5° W	10.62	N 25° W	9.7804 N	4.1518 W	34.6412 N	10.5996 W

34.6412      13.2953

2.6957

10.5996

Surveyed by \_\_\_\_\_

Reduced by \_\_\_\_\_ Checked by \_\_\_\_\_

the distance column and the bearing given in the column headed reduced bearings.

(2) Each line may be plotted by measuring the consecutive co-ordinates, the latitude or cosine vertically and the departure or sine horizontally, the direction being up or down for N. or S. and left or right for W. or E.

(3) Each line may be plotted by using the independent co-ordinates, measuring all the latitudes from the commencement of the survey and all the departures from the meridian line through the first station.

For practice, all three methods may be carried out upon the same survey plan as in Fig. 110.

The following field notes, without offsets (Fig. 111), give the lines of a closed traverse, with the bearings taken by a

prismatic compass or circumferentor, all the angles being taken east of north, the compass ring or card being marked continuously from 0° to 360°. The bearings may be reduced as before and latitudes and departures taken from traverse tables. In the previous example these were entered in single columns, but it is a little more convenient to place them in

11·50	⊙
(7)	275°30'
5·18	⊙
(6)	317°
8·27	⊙
(5)	230°
10·20	⊙
(4)	157°
5·62	⊙
(3)	83°
8·14	⊙
(2)	64°
7·22	⊙
(1)	37°

Closed Traverse  
by Compass  
Mag Var. 18°W

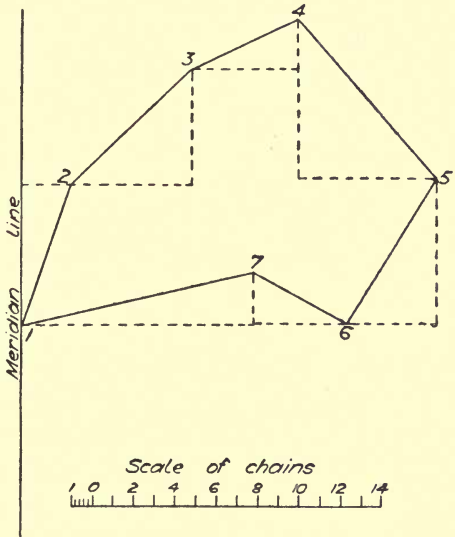

FIG. 112.—Plotting for same.

FIG. 111.—Field notes for closed traverse.

double columns, as in the following form of reduction (p. 110).

It is seldom that the measurements and observations will be so accurate that a closed traverse will exactly close. In the above example it will be seen that there is a small error, making the last position 0·1328 chains N. and 0·1527 chains W. of the true place. The plotting of this survey is given in Fig. 112.

Surveying on the meridian and perpendicular system is the same as the method used in reducing a traverse survey to

a single meridian. It consists of calculating and plotting the latitude or cosine and the departure or sine of every observed

REDUCTION OF CLOSED TRAVERSE BY TABLES

Survey of \_\_\_\_\_ Date \_\_\_\_\_ Mag. Var.  $18^{\circ} W$

Station or Line	Observed bearing	Distance	Reduced bearings	Latitude		Departure	
				Northings	Southings	Eastings	Westings
1	$37^{\circ}$	7.22	$N19^{\circ}E$	6.8279		2.3506	
2	$64^{\circ}$	8.14	$N46^{\circ}E$	5.6573		5.8507	
3	$83^{\circ}$	5.62	$N65^{\circ}E$	2.3724		5.0921	
4	$157^{\circ}$	10.20	$S41^{\circ}E$		7.6980	6.6918	
5	$230^{\circ}$	8.27	$S32^{\circ}W$		7.0094		4.3831
6	$317^{\circ}$	5.18	$N61^{\circ}W$	2.4716			4.5275
7	$275^{\circ}30'$	11.50	$S77^{\circ}30'W$		2.4890		11.2273
				17.3292	17.1964	19.9852	20.1379
				17.1964			19.9852

Surveyed by \_\_\_\_\_ Error  $\frac{.1328}{17.1964}$   
 Reduced by \_\_\_\_\_ Checked by \_\_\_\_\_

angle and distance instead of plotting the angle with a protractor and marking off the distance. In plotting a traverse by chords a table of sines can be used. Strike an arc with a radius of 5 units and cut it with a chord to the same scale of 5 times "twice the sine of half the angle," i.e.  $10 \sin (\frac{1}{2}A)$ .

### QUESTIONS ON CHAPTER XV.

1. Show by a sketch the difference between an open traverse and a closed traverse, and explain how they are plotted.
2. What is meant by "rectangular co-ordinates," and what is their application to a compass survey?
3. How do traverse tables differ in their use from tables of sines and cosines?
4. Describe the method of using a "Scale of Chords" in plotting an angle.
5. In calculating a closed traverse, why do the first and last positions seldom agree?
6. In a protractor 10 inches diameter, what will be the linear measurement of 10 minutes of arc? (Ans.: 0.0145 in.)

## CHAPTER XVI.

Copying plans by tracing and photography—Use of triangular compass—Pricking through and transfer—Enlarging and reducing by proportional squares—Use of proportional compasses—Use and adjustment of pantagraph and eidograph—Ordnance maps.

**Copying plans.**—Reference was made in Chapter VIII. to the two principal kinds of plans produced by the surveyor, viz. office plans to a large scale uncoloured and with the chain lines shown, and the finished plans reduced to a small scale, coloured, and finished off artistically, for the use of the surveyor's client. It happens from time to time that copies of plans have to be made either upon the same scale as the original, or to a reduced scale; and sometimes, but rarely, to an enlarged scale. The various methods by which these copies of plans are made will now be described.

**Tracing.**—The simplest way is to copy the plan by tracing, tracing paper or linen being put over the original plan and the lines inked in, exactly in the way the original drawing was inked in. The tracing when on paper may afterwards be mounted by nailing down a piece of cotton, linen, or holland upon an old drawing board, then pasting and sticking upon it a piece of lining paper, and lastly pasting and sticking the tracing upon that. Linen tracings are made upon prepared linen to save the expense of mounting, and now photography is very largely used. A tracing in bold lines is made upon blue shade tracing paper, and this being used as a negative, a "blue print" with white lines on a blue ground is produced, or, at slightly greater expense, lines in purple, brown, or black, upon a white ground.

If the original plan is to be copied upon drawing paper, it must be traced through upon a tracing frame, which consists of a sheet of plate-glass in a hinged frame, which can be set up at

an angle of say  $30^\circ$ . It is put in front of a window and the blind pulled down to the level of the top of the frame so that the light from the lower part of the window enters underneath the glass and shows up the lines through the paper.

**Pricking through.**—Another mode of copying plans to the same scale, upon drawing paper, is to place the original over a clean sheet of paper and to prick through with a needle at every angle or junction of lines, and at a sufficient number of points along an irregular boundary to enable all the lines to be drawn when the original is removed. If the paper upon

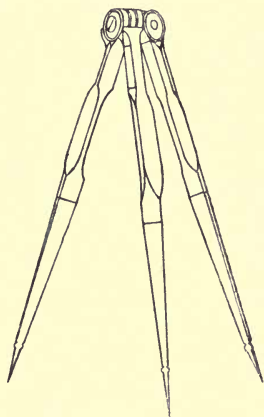

FIG. 113.—Triangular compasses.

which the original drawing is made is sufficiently thin, the drawing may be transferred by inserting a piece of carbon transfer paper, or what is better a sheet of tracing paper black-leaded on the underside, between the original and the clean sheet of paper. The whole of the outlines are then traced over with a blunt tracer of agate or steel, the pressure transferring the black-lead where required to the plain sheet of paper. These outlines are afterwards inked in and coloured in the ordinary manner. A pair of compasses with three legs, known as triangular compasses and shown in Fig. 113,

is extremely useful for copying small plans, two of the legs being set to the extremities of a base line; the third one will give any required point with regard to this line, so that all points of a plan can be transferred in sequence.

**Enlargement and reduction of plans.**—When the copy has to be enlarged or reduced the method adopted will depend upon circumstances. The simplest method without special instruments is by the use of **proportional squares**, as shown in Fig. 114. If squares be drawn upon the original plan measuring say one chain each way, or tracing paper with similar squares be used to lay over it, then lines may be drawn upon the clean sheet of paper representing the squares shown to the



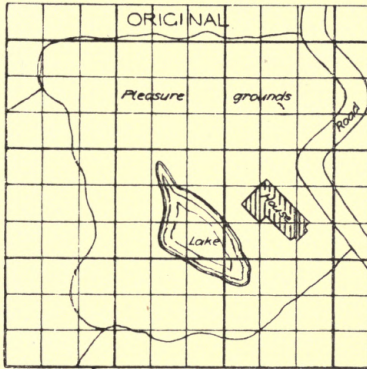

Scale - 60 feet to 1 inch

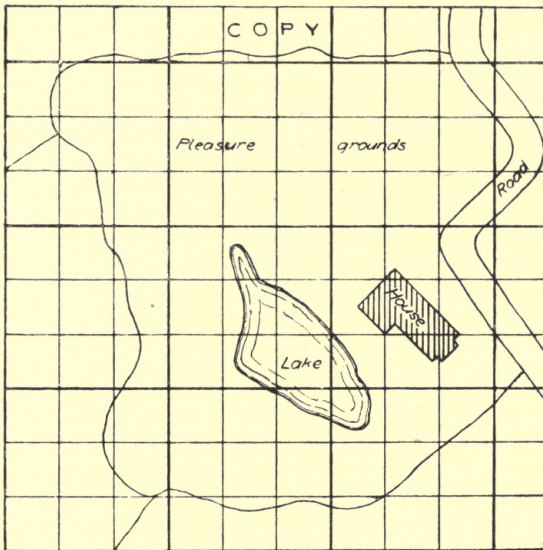

Scale - 40 feet to 1 inch

FIG. 114.—Method of enlarging by proportional squares.

required scale, all the outlines upon the original being drawn across the squares of the required plan by the eye.

**Proportional compasses**, as shown in Fig. 115, may be used for fixing the proportionate distance along any square where a line to be copied should cross, also for enlarging or reducing a straight lined plan. The pivot is adjustable, so that the legs may open in any required proportion. Various scales are marked upon these compasses, but the scale of lines is the only one commonly used. Suppose the pivot to be set to 5 on the scale of lines, it means that the long points will open 5 times

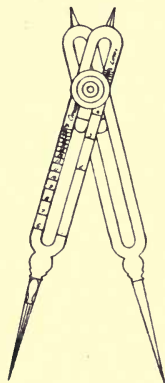

FIG. 115.—Proportional compasses.

as far as the short points in any position of the legs, so that any distance upon an original drawing may be enlarged or reduced in any given proportion for the required drawing. With this instrument the drawing has to be constructed, or the survey plotted, almost as fully as if the original drawing were being made.

The **Pantagraph** and **Eidograph** are two very important instruments used for copying plans; they are sometimes used for copying to the same size, rarely for enlarging, and very frequently for reducing.

The **Pantagraph**, shown in Fig. 116, is supposed to be the most ancient of all mathematical contrivances for copying on an enlarged or reduced scale, and is said to have been invented about the year 1603 by the Jesuit Scheiner, then a professor in the German Academy at Dillingen. It consists of two long arms pivoted together at one end, and two short arms pivoted together at one end, and each pivoted to the centre of one of the long arms. These are supported by small rollers, and one of the long arms is pivoted upon a weight which holds the instrument in place. The other long arm carries a tracing point for passing over the lines of the original plan, and one of the short arms carries a lead pencil for drawing reduced copies. The pencil is connected by a cord to the tracing point, where a loop is placed for the finger in order that the pencil may be raised when passing over the space between two lines.

There are two ways of using the Pantagraph, the erect and

reverse, the former showing the copy the same way up as the original, and the latter producing it reverse or upside down. For erect copies the fulcrum is placed on the long arm B and the pencil point on the short arm A, and in reverse copies the positions of the fulcrum and pencil are simply reversed. There are two rows of numbers on the beams—the right-hand row refers to reduction in the erect manner, the left-hand column to reductions in the reverse manner, so that remembering this no calculation is required. The numbers relating to erect copying may, however, be used for reverse copying, and *vice versa*; but they will give other proportions which are only occasionally

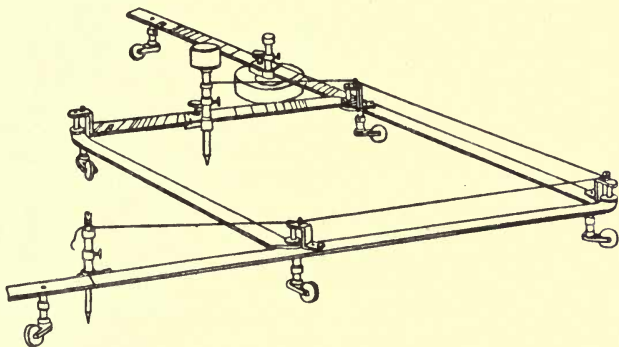

FIG. 116.—Pantagraph.

required and a student need not trouble about them until they are actually wanted.

The Eidograph (Fig. 117), invented by Professor Wallace in 1821, is used for similar purposes to the Pantagraph, but is more elaborate and expensive, and also more correct. It consists of a centre bar with a vernier, pivoted upon a heavy block. At each end is a roller connected with the other by an adjustable steel band; these rollers each carry clamping boxes through which the tracer and the pencil arms pass. To set the instrument to reduce or enlarge to any required proportion, take the sum and the difference of the two proportional numbers, then say, as the sum is to the difference so is 100 to the numbers required upon the arms and centre bar. Thus, to reduce in the proportion of 3 to 2, say  $3 + 2 = 5$ ,  $3 - 2 = 1$ ,

then  $5 : 1 :: 100 : 20$ , 20 will be the division to set the centre bar to, on the pencil side of O, the tracer arm is to be lengthened to 20 and the pencil arm shortened to 20. When the drawing is to be enlarged in the same proportion the tracer arm will be shortened and the pencil arm lengthened, the centre bar being set to 20 upon the side away from the pencil.

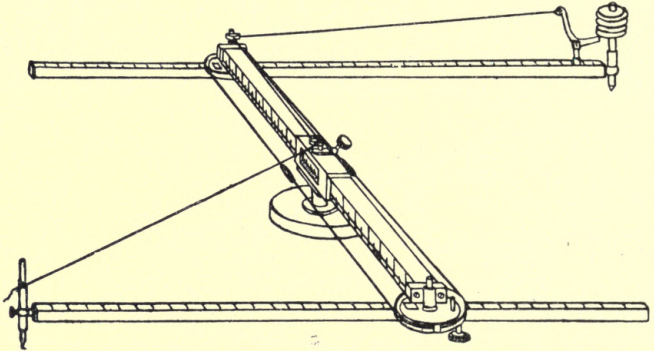

FIG. 117.—Eidograph.

**Common scales of ordnance maps.**—The common scales of Ordnance maps are as follows :

$$\frac{1}{63360} = 1 \text{ inch to a mile, is the small scale.}$$

$$\frac{1}{10560} = 6 \text{ inches to a mile, is the medium scale.}$$

$$\frac{1}{2500} = 25\cdot344 \text{ inches to a mile, is the large scale.}$$

$$\frac{1}{1056} = 5 \text{ ft. to a mile} = 88 \text{ ft. to an inch, is a special scale for towns.}$$

$$\frac{1}{528} = 10 \text{ ft. to a mile} = 44 \text{ ft. to an inch, larger scale for towns.}$$

$$\frac{1}{500} = 10\cdot56 \text{ ft. to a mile} = 41\cdot66 \text{ ft. to an inch, is the new Ordnance scale for towns.}$$

Tithe and parish maps are usually  $\frac{1}{2376} = 3$  chains to an inch, which gives nearly one acre to the square inch.

Small estates and single fields are often plotted to  $\frac{1}{792} = 1$  chain to an inch.

Engineers' working plans are sometimes drawn  $\frac{1}{1200} = 100$  ft. to an inch, but the Ordnance scale of  $\frac{1}{1056}$  is more convenient.

As areas depend upon square measure, a mistake in scaling requires the use of squaring to correct it. For example, having used a 3-chain scale for computing the area of a field upon a plan drawn to a scale of 2 chains to an inch, the result was 5 acres 3 roods, whereas the true area would be  $5\text{a. } 3\text{r.} \times \frac{2^2}{3^2} = 2\text{a. } 2\text{r. } 9\text{p.}$  nearly.

Scales can be converted from one to another with a little consideration. For example, to convert "25·344 ins. to 1 mile," to "chains to 1 inch," the ratio is 25·344 ins. to 80 chains, hence in 1 inch there will be  $\frac{80}{25\cdot344} = 3\cdot15$  chains.

To make a scale to measure the chains note that 25·344 : 80 is practically 5 : 16, therefore draw a line 5 inches long and divide it into 16 parts each 1 chain.

### QUESTIONS ON CHAPTER XVI.

1. What different methods are in use for copying survey plans to the same scale ?
2. Describe and illustrate the method of enlarging a plan by proportional squares.
3. Make a sketch of a pantagraph and describe its use in reducing a survey plan to half size.
4. State the general scales of Ordnance Maps for various purposes.
5. Explain the use of triangular compasses and proportional compasses.
6. What will be the value in feet to 1 inch of a scale of  $\frac{1}{2500}$ .

## CHAPTER XVII.

Definition of levelling—Datum line—Gravatt's dumpy level—Construction of level—Construction of level staff—Curvature and refraction.

**Levelling.**—Chain surveying forms the first portion of a land surveyor's professional education; it enables him to map any plots or districts of tolerably level land, but with that knowledge alone he cannot attempt to set out any new roads, or lay out a system of sewerage, or project a line of railway; or, in fact, deal with any of the more important work of the profession. Chain surveying may be described as surface work, whereas **levelling** has to do with the height of the different portions.

**Levelling** may be defined as the art of determining the heights of any number of points above an imaginary line everywhere equidistant from the centre of the earth.

This line, technically known as a **datum line**, is usually spoken of as level, but it must neither be looked upon as horizontal nor straight; it is really curved with a radius of rather less than 4000 miles, the mean radius of the earth, and is the shape assumed by a vertical section through the surface of still water.

**Gravatt's dumpy level.**—The instrument generally used for determining these heights is called a **level**, and is a combination of a spirit level with a telescope. The one most used by surveyors in ordinary work is **Gravatt's dumpy level** (Fig. 118). It is preferred because it is less liable to get out of adjustment than older forms, but it contains many unnecessary details, particularly the compass. The compass is an instrument of direction, whereas the level, in its ordinary use, has nothing to do with direction, and the compass in the Gravatt level is in such an awkward position that it is very difficult to read it accurately. A 10-inch

builders' dumpy is a light handy instrument, quite sufficient for ordinary work, but the larger instrument is necessary for railway work and road surveying of any magnitude.

The level is screwed on top of a tripod, as three legs will stand firm, however irregular the ground may be.

The parallel plates, AA, hold between them a ball and socket joint, so that the upper portion can be tilted in any direction by the four parallel plate screws, BBBB. C is a

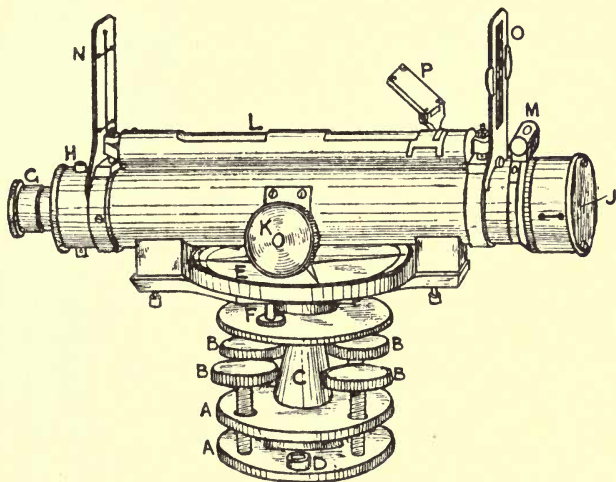

FIG. 118.—Gravatt's dumpy level.

socket attached to the upper plate in which the vertical spindle of the telescope rotates. D is a centre-bubble spirit level for roughly adjusting the legs. E is a compass with a tripping screw F. G is the eyepiece of the telescope containing lenses, making it virtually into a microscope for magnifying the image thrown upon the intersection of the cross wires in the diaphragm at H. The object glass J is focussed by means of the milled head screw K and internal rack. The bubble of the main spirit level L is adjusted by setting it over a diagonal pair of the parallel plate screws, while the cross spirit level M is adjusted by the other pair.

N and O are sight vanes for putting the telescope approximately in the right direction.

There are many details in connection with the instrument which only an expert need trouble about, as the full description would probably mislead most young surveyors. For instance, in Mr. Gravatt's description we find the following paragraph: "On the bubble tube slides the mirror C, which is of great assistance in reading the bubble on

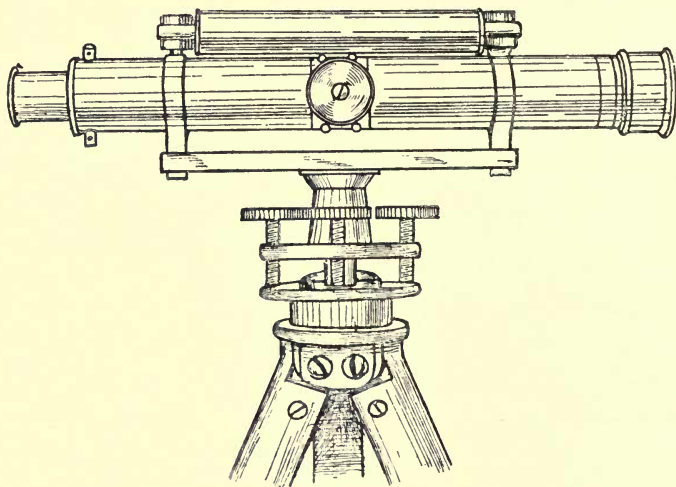

FIG. 119.—Builders' or contractors' level.

spongy ground or in windy weather; a little practice enabling the leveller to observe the staff through the telescope with one eye, whilst with the other he observes that the bubble is not disturbed by his shifting his position. If he be disturbed, he can set it right without changing his position; and if he have the free use of both his eyes, he can read the staff and correct the bubble at once by simply pressing the level legs."

The builders' or contractors' dumpy level is shown in Fig. 119. This has no unnecessary fittings, but has everything that is requisite for ordinary work. Its cost is under £5.



The theoretical object of a level is to obtain a perfectly horizontal line of sight from the observer's eye, the height being taken upon a staff at the other extremity of the line.

**Construction of level staff.**—There are various forms of



Fig. 120.—Level staff.

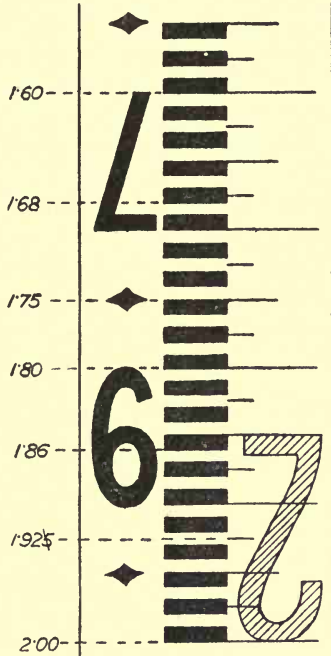

Fig. 121.—Enlarged view of portion of staff.

levelling staves, but that most used by surveyors is known as the **Sopwith pattern** (Fig. 120), arranged in telescopic lengths. This consists of a mahogany box, 5 feet long, 4 inches broad, and 2½ inches deep, within which is another hollow box, 4 feet 6 inches long, made so that it will slide easily within the other, whilst a solid mahogany staff again works within the latter, so that when pulled out to their full length,

having springs or clips to secure them, they represent a staff 14 feet long.

Fig. 121 shows an enlarged view of a portion of the level staff as it appears upon looking through the telescope. It is divided in feet by red figures, the figure for 2 feet being shown in the diagram; each foot is divided into ten parts, the alternate tenths being indicated by black figures as shown, each figure extending over the whole space. The tenths are divided again into ten parts by black strokes and white

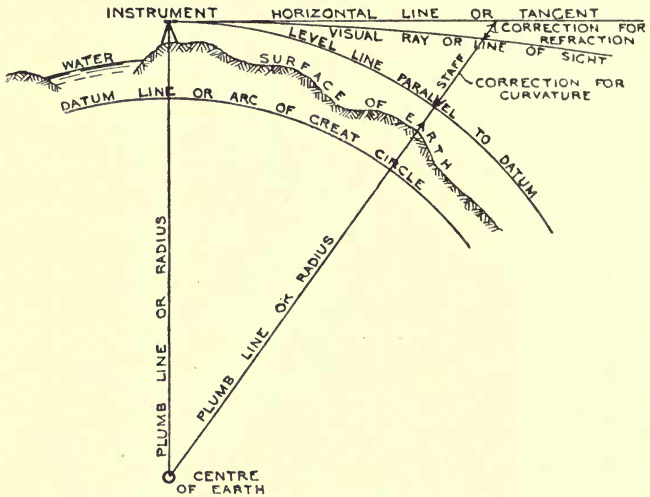

Fig. 122.—Difference between level and horizontal lines.

spaces, each measuring one hundredth of a foot. Several "readings" are marked upon the diagram to indicate the method of using the staff. When a half division is cut by the wire, the third decimal is omitted as at 1.925. The staff appears upside down in the telescope, so that the readings are taken from above downwards, and the surveyor experiences no difficulty in this after a little practice; in fact, he is so used to it that he is not aware of it being upside down, unless a stranger looks through the telescope and calls his attention to it. It would be possible, by increasing the number of lenses, to get an erect image, but this would be at the expense

of some of the light passing through to the eye, and all the light that is possible is needed in taking long sights, *i.e.* reading the staff at a considerable distance.

**Curvature and refraction.**—When the difference in level between two distant points is required, correction must be made for **curvature** and **refraction**.

Curvature is the difference between a truly horizontal line and what is properly known as a level line, *i.e.* one following the curve of the earth.

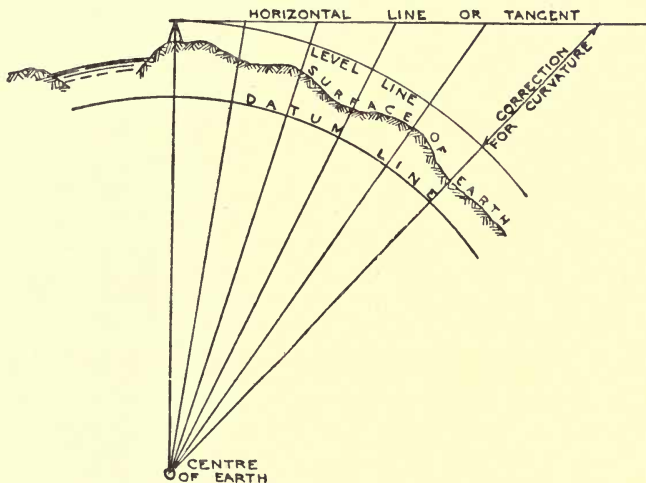

Fig. 123.—Correction for curvature.

Refraction is the apparent raising of the object observed, by reason of the bending of the rays of light from the object in passing through the atmosphere.

Fig. 122 will make quite clear the distinction between the terms straight, level and horizontal. Seeing that the instrument gives horizontal lines only, while for determining the heights of various points level lines are required, the reduction from one to the other, or the correction for curvature becomes an important matter. Fig. 123 shows how rapidly the correction increases with increase of distance. In this case the horizontal line appears in the position that would ordinarily be called

horizontal, but a tangent line perpendicular to any radius of the earth would equally be entitled to be called horizontal. The apparent height of any object reaching the horizontal line when seen through the telescope would be that of the observer's eye, say 5 feet, but the actual height will vary according to the distance. The difference is about 8 inches or two-thirds of a foot for the first mile, but increases as the *square* of the distance, and thus a very simple formula may be obtained :

$$(\text{Distance in miles})^2 \times \frac{2}{3} = \text{correction in feet.}$$

The refraction is variable according to the state of the atmosphere, but it is generally assumed to be one-seventh of the curvature, and is always deducted from it, or in other words the effect of curvature is always lessened by the effect of refraction.

In some text-books it is stated that if the observation be taken to some fixed point at a distance, as the crest of a hill, the correction for curvature must be added, but if taken on a staff it must be deducted. Now, the observation is never taken practically without a staff, and therefore all cases will come under one rule, which is as follows :

Height of reading - height of instrument - correction for curvature + correction for refraction = comparative level of the two stations.

It has been stated above that the correction for refraction is always deducted from that for curvature, and it is really so in this rule, for the *whole* curvature having been deducted the refraction must be added, which is the same as first reducing the curvature by the refraction. For example, if the reading on the staff by the telescope at a distance of 25 chains is 7.49, the height of the telescope 5.26, the difference of level

$$\text{between the two stations will be } \left(\frac{25}{80}\right)^2 \times \frac{2}{3} = \frac{1250}{192000} = 0.065,$$

$$\frac{0.065}{7} = 0.009, 7.49 - 5.26 - (0.065 - 0.009) = 2.174 \text{ ft. difference}$$

of level, the instrument being higher.

It is necessary to be aware of all the facts above stated, but for short distances, such as occur in ordinary work, no correction is required. By the method adopted in adjusting the level for collimation, which will be explained later, the

allowance is adjusted automatically, although if it were not, the error in a length of 10 chains would be only about  $\frac{1}{100}$  of a foot.

### QUESTIONS ON CHAPTER XVII.

1. Explain what is meant by "levelling a section."
2. What is a datum line and how is it determined?
3. Explain how a level line differs from a horizontal line.
4. Sketch the construction of a level and describe its adjustment.
5. Explain the corrections for curvature and refraction.
6. Sketch full size, six inches of a levelling staff, marking the divisions upon it, including a foot figure, and indicate three readings.

## CHAPTER XVIII.

Simple and compound levelling—Parallax and collimation, and adjustments therefor—Bubble error and its adjustment—Setting up a level—Holding the staff.

**Compound levelling.**—All the remarks in the previous chapter have been directed to what is called simple levelling; but there is another method, called **compound levelling**, by which all the difficulties of curvature and refraction are legitimately avoided, even in long lines. The expedient is very simple and is shown in Fig. 124.

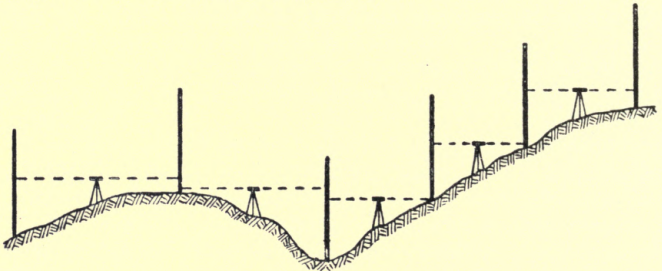

FIG. 124.—Compound levelling.

By placing the level midway, or thereabouts, between the successive stations which are selected, the effects of curvature and refraction are neutralized, for it is evident that if the instrument were exactly midway between two stations, upon the same level as in Fig. 125, the back and fore sights would show the same reading, being both subject to the same amount of correction, and if any difference of level existed it would be shown simply by the difference of reading without needing any correction. This is the method adopted in practical

levelling, and although the instrument cannot often be set exactly midway between two positions of the staff, the error cannot exceed that due to the difference of distance on the two sides. Briefly, we may say that "simple levelling" is reading forward to the staff from one station only, while "compound levelling" is when the level is placed between two staves, or two positions of the staff, and a reading taken from each.

**Parallax and collimation.**—There are two adjustments requiring attention in connection with the level, one is for parallax and the other for collimation.

**Parallax** is the apparent movement of the cross wires when taking a reading, which is so perplexing to beginners. It is partly due to the foci of the object glass and eye piece not falling together upon the cross wires, and partly to the width

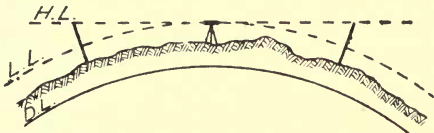

FIG. 125.—Corrections equal when distances equal.

of the aperture of the eye piece allowing too great a range of movement to the eye.

The adjustment for it consists in first focussing the eye piece so that the wires are perfectly distinct, and then focussing the object glass so that the figures on the staff are also perfectly distinct. Sometimes, owing to the position of the sun in front of the telescope, it will be necessary partly to shade the object glass with the hand, or to hold a piece of white paper in front of it, to see the wires distinctly. To overcome the difficulty of width of aperture the eye must be kept as nearly as possible in the centre of the aperture. With a single observer there is no difficulty in adjusting for parallax, but with a class of students using the same instrument it may need alteration to suit individual eyesight. When the cross wire seems to make a regular pulsation it will be due to the heart-beats of the observer, as he will find by placing his fingers on his wrist and noting the coincidence of the movements.

Astronomically, parallax is the apparent change of position of an object when viewed from different places, and when it

is said that a fixed star has no parallax, the meaning is that, when viewed from opposite extremes of the earth's orbit, roughly a base line of 200 million miles, the angle appears to be unaltered, showing the infinite distance of the star compared with this comparatively long base line. Even in the case of the nearest star—Alpha Centauri—the angle between two lines drawn from the star to the ends of this great base line is only 1.5 seconds of arc.

Under the head of **collimation** two or three different adjustments are usually included. In the first place, a line joining the centre of the object glass with the intersection of the cross wires is called the "line of collimation." A line joining the centre of the eye piece with the centre of the object glass is called the "optical axis" of the telescope. A centre line

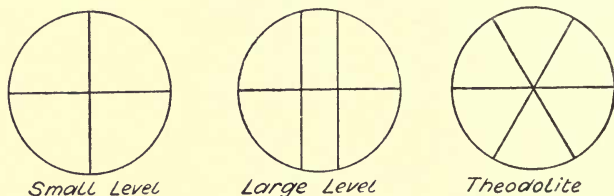

FIG. 126—Arrangement of wires in levels and theodolite.

through the spindle or axis upon which the level turns is called the "vertical axis." Then the spirit level may be considered to have an axis or centre line such that this line is truly horizontal when the bubble is in the centre of its run. Now when the level is in adjustment the line of collimation must pass through the optical axis and be parallel to the axis of the spirit level and perpendicular to the vertical axis.

**The adjustments for collimation** vary in the different forms of level, and should as a rule be left to the makers, except in the case of the diaphragm requiring a new wire, which every surveyor should learn to put in and adjust afterwards. Fig. 126 shows the general appearance of the aperture in the diaphragm with the wires. Suppose one of these to be damaged, the surveyor must take the diaphragm in his hand and put a drop of stiff gum or glue on each side and then lightly strain a thread from a spider's web across it, give it a minute or two to set, and then cut the loose ends off with a pair of scissors.



Marks will generally be found upon the diaphragm to show where the wire should cross it. The diaphragm should then be replaced, and the adjustment will be carried out by proceeding as in Fig. 127.

Set the level up midway between two stakes driven in the ground about four chains apart. With the bubble central for each reading, whether it reverses properly or not, sight the staff at A and B and drive down the stake that gives the lesser reading until they are both equal. Then shift the instrument to about 20 links from one of the stakes and take the reading from both. As they are both at the same

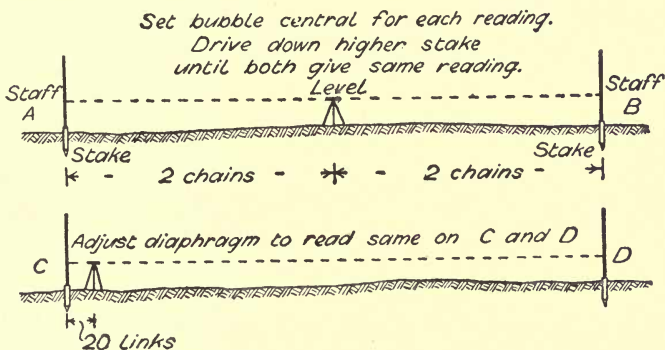

FIG. 127.—Adjustment of level for collimation.

level they should give the same reading, and if they do not, by slackening one of the diaphragm screws on the vertical line and tightening the other, it will soon be seen which way the diaphragm should be moved to make both readings alike.

**Bubble error.**—If the bubble does not remain central when the telescope is reversed there is a **bubble error**. This may generally be neglected if the bubble is set in the centre of its run for each direction of reading, but it may be easily corrected by shifting it half the required distance by means of the parallel plate screws and the other half by the clamping nut under the end of bubble tube.

**Setting up a level.**—In setting up a level preparatory to taking a reading, first see that the parallel plates are parallel,

or nearly so, and alter if necessary by the screws. Let the screws be just up to their work, not jammed, nor off the lower plate. Then open the legs equally to an angle at the top of about 30 degrees, or 75 degrees elevation from the ground. Stand between two of them and grasp the head of the tripod with the left hand just below the parallel plates. Turn the telescope across the direction of the leg on the right, and holding the leg about the middle, move it to or from you until the bubble is central, when the point of the leg is on the ground. Then turn the telescope in the direction of the leg on the right and move it in or out to bring the bubble central in that direction. See that the legs are firmly set in that position, and then with both hands released, set the telescope over a diagonal pair of the parallel plate screws and obtain the final adjustment by the screws, the direction for movement being "thumbs in for bubble to the right, thumbs out for bubble to the left." Then turn the telescope over the other pair of screws and adjust. The bubble should now remain central in any position of the telescope, and if it does not it is better to let the maker examine it and put it right.

The next step is to focus the eye piece until the wires are distinct, always turning it to the right while moving in or out, to avoid the chance of losing the cap or pulling out the eye piece like a cork and damaging the wires by the rush of air into the telescope. The object glass is adjusted for each reading, and no attempt should be made to raise or depress the eye piece in order to get a red figure within the field of vision. When the telescope is so close to the staff as not to show a red figure, the latter can be read from the outside by looking along the barrel of the telescope level with its centre to see where it points.

To adjust the screws of a **tribrach** or three-screw level, the telescope is first placed parallel with the paired screws and adjusted in the ordinary way, and then over the single screw which is adjusted to bring the bubble central. A surveyor who has been used to the four-screw level fails to find any advantage, in time or convenience, in the newer form, unless perhaps on rough ground or hill-sides, where it may afford rather more range in the position of the legs without straining the screws.

"An ounce of practice is worth a pound of theory," and an

early opportunity should be taken to practise the operations described above. A beginner after a little practice should be able to set up and adjust a level in one minute and level twice over the same mile, *i.e.* there and back, without a greater difference in the result than one-tenth of a foot. If anyone is nearer than that without much practice the accuracy is accidental. Learn first to work accurately and afterwards rapidly, speed soon comes with systematic work. In levelling long lines the permissible error is proportionately less, varying as the square root of the distance, *e.g.* 9 miles =  $\frac{3}{10}$  foot.

There are some curious points in connection with levelling

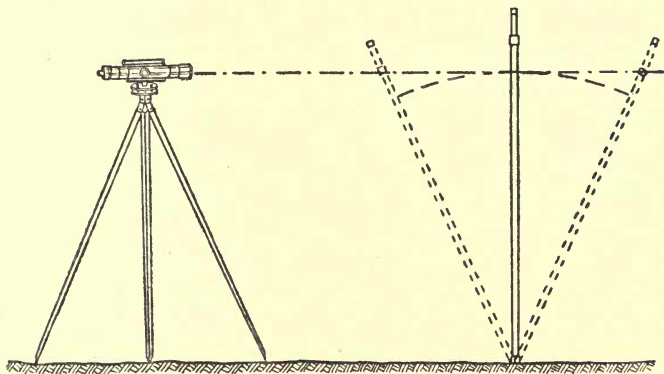

FIG. 128.—Obtaining reading when staff is vertical.

which a careful study of a surveyor's notes will reveal. For instance, Mr. Bunt, a surveyor, in 1837-8 found in 74 miles, that each stage of 2 to 6 miles, although levelled very carefully both ways, always came out less by levels returning than by levels going, or the starting point appeared lower upon returning than upon setting out. In levelling uphill there will be a general tendency to make the backsights too great, and *vice versa*. Also the settlement of the staff in turning round on soft ground increases the reading of the backsights.

**Holding the staff.**—The greatest care should be observed in holding the staff so that it is perfectly vertical when the reading is taken. The staff holder should see that, when wanted, each length is drawn out to its full extent and the

spring clips are secure. Some surveyors instruct their staff holder to stand behind the staff and to wave it slowly backwards and forwards as in Fig.



FIG. 129.—How NOT to use a level.

128, they then take the lowest reading that is seen, as that must necessarily occur when the staff is vertical. It is better, however, that the staff holder should stand at the side and be responsible for keeping it upright, a chance assistant is liable to wave the staff without reaching the vertical. There should be an intelligible code of signals between the leveller and the staff holder, and when once upon a back or fore sight the holder must never move until so directed by the surveyor.

The illustration (Fig. 129) is an example of how not to use

a level. No part of the hands, body or clothes should touch the legs while taking a reading.

### QUESTIONS ON CHAPTER XVIII.

1. Explain the difference between simple and compound levelling. What corrections have to be made in the former case?
2. What is parallax in the telescope of a level and what adjustment is made for it?
3. Define the "line of collimation" and explain how this may differ from the optical axis of a level.
4. Illustrate by sketches and describe how a level is adjusted for collimation.
5. In using a level with a bubble out of adjustment what precaution must be adopted in taking a reading?
6. Describe the setting up and adjusting of a three-screw level ready for taking a reading.

## CHAPTER XIX.

Levelling a section—Running or flying levels—Check levels—Bench marks—Ordnance datum—Reducing levels—Plotting sections—Minus readings.

**Levelling a section.**—In levelling over any ground for the purpose of obtaining a section, it is requisite to measure the distance between the various stations of the staff, but the completeness of the Ordnance Survey maps renders this in some cases unnecessary. In all cases it is of very great assistance to have the Ordnance map of the district traversed, but where this is not available the operations generally involve chaining as well as levelling. For merely finding the difference in level between two distant points, or checking the levels of a previous survey, no measurements are needed.

**Running or flying levels.**—The simplest work in levelling consists of taking running or flying levels for the purpose of ascertaining the relative height of two points, the starting point and the terminal point. In this case, if the distance require more than one sight to be taken, compound levelling is adopted, as explained in the last chapter, the stations for the staff being taken as far apart as the figures can be read, irrespective of the nature of the ground, *i.e.* without regard to the level of intermediate points.

**Check levels and bench marks.**—Almost as simple is the work of taking “check” levels, which consists of checking the heights of various points along a line previously levelled. These points are, at certain levels, greater or smaller according to the nature of the work, selected by the person who made the original section, and are generally curbstones, milestones, coping stones of bridges, plinths, hinges of gate posts, stakes, marks cut on trees, walls, etc.—in fact, anything easily found again and not likely to shift. All these points are known as

**bench marks.** They are marked on the survey plan "B.M. No. —," with a description of where they are to be found.

Bench marks should be recorded about every half mile, so that in case of accident a return may be made to the last bench mark without much extra labour. The first bench mark should be referred to some well-known level in the neighbourhood.

**Ordnance datum.**—The standard or **Ordnance datum** is the assumed mean half-tide level of the sea at Liverpool, marked on the entrance to the Mersey Docks, and all the figures indicating the level on Ordnance Maps are the heights above this datum. It is now found, however, that Ordnance datum as fixed at Liverpool is 0·65 feet below the general mean level of the sea as determined by observation at 32 places on the coast of England and 18 on the coast of Scotland.

The H.W.M. of ordinary tides on Ordnance maps represent mean tides, *i.e.* tides half-way between spring and neap, and are generally surveyed at the fourth tide before new and full moon. Trinity High-Water Mark, which is much used as a datum in London, and is required to be marked on all drawings of sections of property adjacent to the river when submitted to the Thames Conservancy, is 12 feet 6 ins. above the Ordnance datum (or, more exactly, 12·48 feet). It is the level of the lower edge of a stone fixed in the face of the river wall upon the east side of the Hermitage entrance to the London Docks. It may be remarked here that all retaining walls, embankments, etc., adjacent to the river Thames must be carried up to a height of 5 ft. 6 in. above T.H.W. This was formerly 5 feet, but in consequence of floods, said to be due to the Thames Embankment, it has been increased to 5 ft. 6 in.

The ordinary ruling of a level book for each opening is shown below in Fig. 130.

In taking running levels, the staff is first of all set up on some point which is to be the starting place, and should be such as may be easily recognised at a future time. The level is then carried forward to a distance of 2 or 3 chains, less or more, according to the nature of the ground, the clearness of the weather, and the size of the instrument. It is then adjusted and directed to the staff. The height is recorded in the level book under the column "back sight," and in the column of remarks is entered "B.M. so and so," describing its position exactly. Then the level remaining in

the same position, the staff is carried forward an equal distance beyond it, and the height read off and entered in the column "fore sight," in the next line. The staff is then turned round, but kept upon the same spot, while the level is carried forward to any convenient distance, the height of the staff being now read as a "back sight" and put on the same line in the book as the last fore sight, because it is really the same point read from a different position. The same course of operations is repeated until the destination is reached. Then by adding up the two columns and putting the smaller under the greater, and subtracting, the difference in level will be obtained. If the fore sights make the greater total, the starting point was the higher, and *vice versa*, or the larger reading for fall, smaller for rise.

*Space for name of place and date*

BACK SIGHT	INTER-MEDIATE	FORE SIGHT	RISE	FALL	REDUCED LEVELS	DISTANCE	TOTAL DISTANCE	REMARKS

← - - - Left hand page - - - → Right hand page →

FIG. 130.—Ruling for level book.

**Reducing levels.**—Now it is evident that between *each* back and fore sight there must be a certain rise or fall; if then the rise or fall at each point be entered in the proper column, it can be carried further, and under the column of **reduced level** or "height above base," by addition or subtraction, an entry can be made of the level of each point above the datum line. Every page should begin with a back sight and end with a fore sight. Then at the foot of each page the rise column and fall column should be added up, the lesser total put under the greater and subtracted, and if the reductions have been made correctly, the remainder will exactly equal the remainder found under the back and fore sight columns. This is a valuable check upon the accuracy of the entries, and each page of the book should invariably be served in this way, carrying forward to the next page, not the final balance, but the total of each column.

When a true section of the ground is to be made, the distance between each position of the staff must be measured and entered in the column of distances, or all the positions measured in one line from the starting point, and the entries made in the columns of total distance similar to a chain line. When the ground varies in level at short distances, intermediate sights are taken and entered in the column of intermediates, the back sight columns being reserved for the first reading after shifting the level forward, and the fore sight column for the last reading before shifting it forward again.

It is necessary to bear in mind that after every back sight,

*Levels at Highbury, London, N.*

*9th May 1900*

BACK SIGHT	INTER-MEDIATE	FORE SIGHT	RISE	FALL	REDUCED LEVELS	DISTANCE	TOTAL DISTANCE	REMARKS
7.02					10.00		0.00	
7.95		3.01	4.01		14.01	1.20	1.20	B.M. on pavement under side of lamp post, corner of Highbury Crescent W.
5.67		2.03	5.92		19.93	1.88	3.08	
6.60		0.88	4.79		24.72	2.00	5.08	
5.36		1.31	5.29		30.01	2.52	7.60	
3.33		0.99	4.37		34.38	2.80	10.40	
	1.02		2.31		36.69	0.80	11.20	
		0.41	0.61		37.30			O.B.M. on pier corner of Ronalds Rd. N.
35.93		8.63	27.30		27.30	11.20		
8.63								
27.30								

*Plot to scales of Hor 1ch = 1in, Vert: 10ft = 1in.*

FIG. 131.—Levels at Highbury, London, N.

however many intermediate sights there may be, there must come a fore sight. These back and fore sights forming two ends of one stage in the levelling. The columns headed back sight, intermediate, fore sight, distance, and remarks, are called **field columns**; while the rise, fall, reduced level, and total distance columns are called **office or plotting columns**, because they can be filled in afterwards.

The method of working out the levels will be understood clearly by reference to the above example (Fig. 131), the levels being plotted as in the section Fig. 132.

**Plotting sections.**—In plotting a section a horizontal line should first be drawn for a datum or base line. This should always be low enough to allow of the surface of the ground



appearing above it at all parts of the survey ; common depths are 20 ft., 50 ft., 100 ft.

After the datum line on a plan is drawn, the distances noted

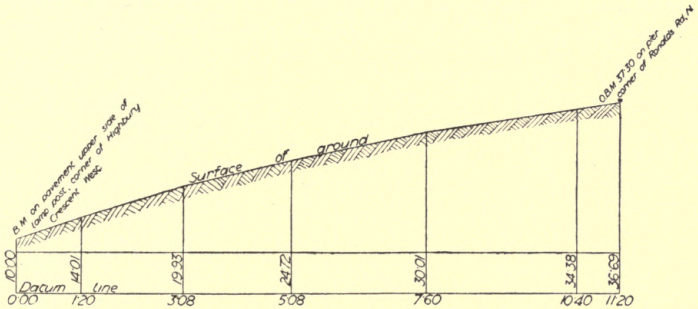

FIG. 132.—Section plotted from Fig. 131.

in the level book, which have been corrected for inclination when chained, should be set off along it, and a perpendicular drawn at each point. Upon these perpendiculars the heights

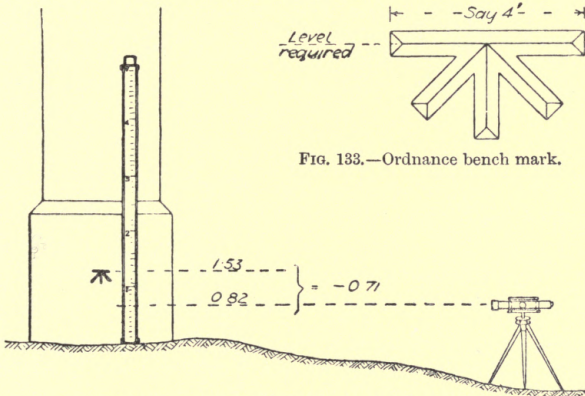

FIG. 133.—Ordnance bench mark.

FIG. 134.—Reading to Ordnance bench mark.

or reduced levels should be marked, and the outlines of the surface of the ground drawn through. The vertical scale of the section is generally much larger than the horizontal, in order to magnify the irregularities of the ground—for instance,

a common proportion is 4 in. to the mile horizontal, and 100 ft. to the inch vertical.

The Ordnance bench mark, as cut on piers and walls, is shown in Fig. 133. In reading to an Ordnance bench mark, as shown on the pier in Fig. 134, if the wire cuts above the

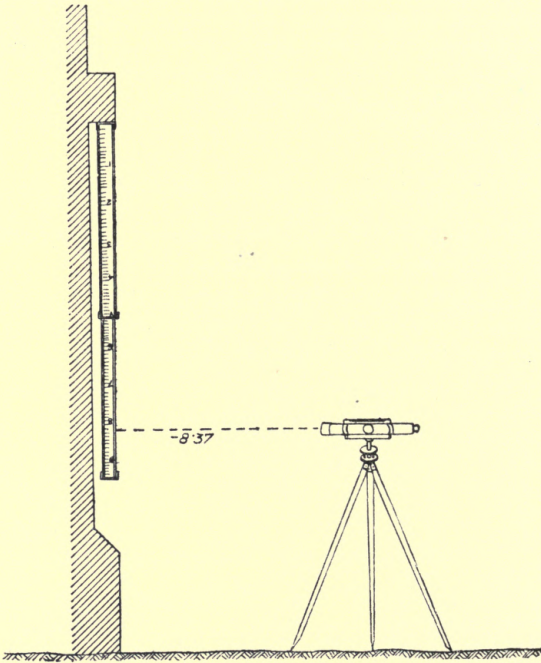

FIG. 135.—Reading downwards from string course.

centre of the horizontal groove, the blade of a pocket knife can be put in the groove and the staff rested upon it while the reading is taken; but if the wire cuts below the mark, the operation will be as shown in the diagram. The staff is rested on the ground against the pier and the reading taken as 0.82, then the centre of the groove is sighted across to read 1.53, then the difference between 0.82 and 1.53 = 0.71, entered in the book as -0.71, because it is a reading from above downwards.

Primrose Hill, Main and Cross-Section 16th May 1900

BACK SIGHT	INTER-MEDIATE	FORE SIGHT	RISE	FALL	REDUCED LEVELS	DISTANCE	TOTAL DISTANCE	REMARKS
2 80					100.00		0 00	B.M. on N.E. corner of stone base to seat on top of Hill
	6 70			3 90	96.10	1.44	1.44	
1 63		11 40		4 70	91.40	1.42	2 86	At junct of cross-roads 160 up road on left 200 " " right
	3 82			2 19	89.21	1.45	4 31	
	2 50		1 32		90.53			
	9 23			6 73	83.80			
0 75		7 39	1 84		85.64	1 20	5 51	
0 30		12 93		12 18	73.46	2 00	7 51	
0 40		11 65		11 35	62.11	1 44	8 95	
2 87		11 54		11 14	50.97	1 42	10 37	
		9 05		6 18	44.79	1 96	12 33	B.M. on pavement at E side of N.E. gateway
8 75		63 96	3 16	58 37	55 21	12 33		
		8 75		3 16				
		55 21		55 21				

Plot to scales of Hor 1ch = 1in., Vert 20 Ft = 1in.

Fig. 136.—Levels at Primrose Hill.

Another case of reading downwards occurs when the underside of a string-course is made a bench mark, as in Fig. 135, giving a minus reading of 8.37. In reducing levels a minus reading is treated in the opposite manner to an ordinary reading, deduct instead of add, or *vice versa*.

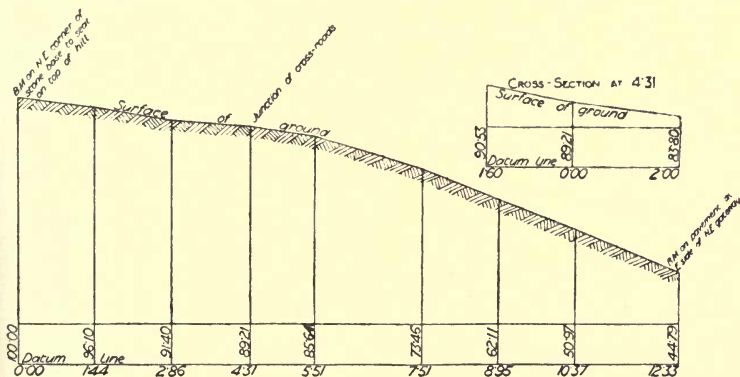

Fig. 137.—Sections plotted from Fig. 136.

The preceding levels (Fig. 136) taken at Primrose Hill, London, show examples of main and cross sections, and the method of plotting them is shown in the accompanying section (Fig. 137).

### QUESTIONS ON CHAPTER XIX.

1. Explain what is meant by running or flying levels.
2. Define the terms "check levels," "bench mark," "Ordnance datum."
3. What is the level of Trinity High Water Mark in London compared with Ordnance datum?
4. Show by a sketch the columns used in a level book, and give three lines of entries.
5. When are "intermediate sights" used in levelling, and how is the reduction of the levels checked?
6. Sketch an Ordnance bench mark full size, and indicate at what part the level is taken.

## CHAPTER XX.

Notes for part of a main section—Plotting of same—Working section of short piece of railway—Description of features shown—Rise and fall method of keeping level book contrasted with collimation method—Telemetry, or optical measurement of distances.

**Part of a main section.**—The following notes (Fig. 138), form part of a main section, and are typical of the work required in levelling over the route proposed for a line of road or railway, and in practice, at each point of a road crossing the line of levels, cross sections would be taken in order to judge of the approaches and what alterations they would require. The fall of the ground across the line of section must be noted in railway surveying to enable the side-widths to be calculated, but this will be dealt with later under engineering field-work.

The plotting of this section is shown in Fig. 139. A study of the remarks column in the level book will show how it is utilised as a field book to give particulars of features and points on the line of section, which are required to be indicated, but where levels are not required to be taken. It should be noted that each page begins with a back sight and finishes with a fore sight, and that the entries are checked by totalling up at the bottom of the page as already described.

The working section of a short piece of railway is shown in Fig. 140, where the gradients laid down upon the section are the flattest available, being so placed as to cause the excavation and embankment to balance each other, and avoiding the provision of a "spoil bank" for excess excavation, or the purchase of embankment material owing to deficient excavation. The part from A to L is in cutting, and that from L to D in embankment, with a bridge over the river at C. The gradient is so arranged as to give headway under

Page 1. *Hickman & Marsden. Final levels.* 29/5/79. Page 2.

BACK SIGHT	INTER-MEDIATE	FORE SIGHT	RISE	FALL	REMOVED LEVELS	DISTANCE	TOTAL DISTANCE	REMARKS	BACK SIGHT	INTER-MEDIATE	FORE SIGHT	RISE	FALL	REMOVED LEVELS	DISTANCE	TOTAL DISTANCE	REMARKS	
9.96					100.00	8 M'		Fallen in the centre on string course of bridge over Canal	86.04		66.18	43.60	23.74	119.86		37.24	Lane X 37.24 & 37.54 Centre of Lane	
3.49	10.85			0.89	99.11			Headland to Marlborough	10.40		3.14	7.26	0.32	127.12		39.50	Headge X 47.03	
2.57	4.81		6.04		105.15	0.67		Bank of Field Road X 0.00 & 0.65	6.25	6.52	1.60	4.92		126.80		42.70	Headge X 44.04	
4.46				1.57	103.58	1.50		Headge X at 4.34	8.13		1.28	6.30		128.02		45.00		
4.63		6.54		3.76	99.82	4.55			8.32		3.67	5.46		142.99		47.00		
6.33		3.12		2.08	89.67	11.00		Mill pond X 12.30 & 15.00	8.28		1.50	6.82		155.27		51.00		
					91.18	12.10		On bank of mill pond	7.13	0.52	1.44	6.80		162.07		52.25	Road X 52.25 & 52.85	
10.18	7.33			1.00	90.18			Surface of water in pond		8.92		5.21		167.28			Road from Aylston Hill to Morescor	
11.94		2.46		4.87	95.05	16.00			0.92		5.91	5.01		165.29		53.00		
4.48		1.08		9.10	104.15	17.50		Headge X 23.33			5.90		4.98	160.31	8 M <sup>3</sup>			On staks driven down by side of road, out of line
6.08		3.53		8.41	112.56	21.00		Headge X 26.72						100.00				
6.75		4.75		0.27	112.29	25.00								60.31				
1.89		6.43		0.35	111.94	28.00		Road X 30.37 & 32.40	148.70		88.33	37.35	37.04					
		9.03		5.75	106.19	30.00		Centre of road from Marlborough to Morescor	88.39									
		3.14		3.61	109.80	31.65		On lower hinge of gate opposite Crown Inn	60.31									
	5.84			6.05	115.85	8 M <sup>2</sup>		Headge X										
86.04		1.83		4.01	119.86	33.50												
66.18		43.60	23.74		100.00													
19.86		23.74	19.86		19.86													

Plac this section to scale of  $\left\{ \begin{array}{l} 5 \text{ chs.} = 1 \text{ in. Hor} \\ 50 \text{ ft.} = 1 \text{ in. Vert} \end{array} \right.$

Fig. 138.—Notes for main section of a railway.

# MAIN SECTIONS

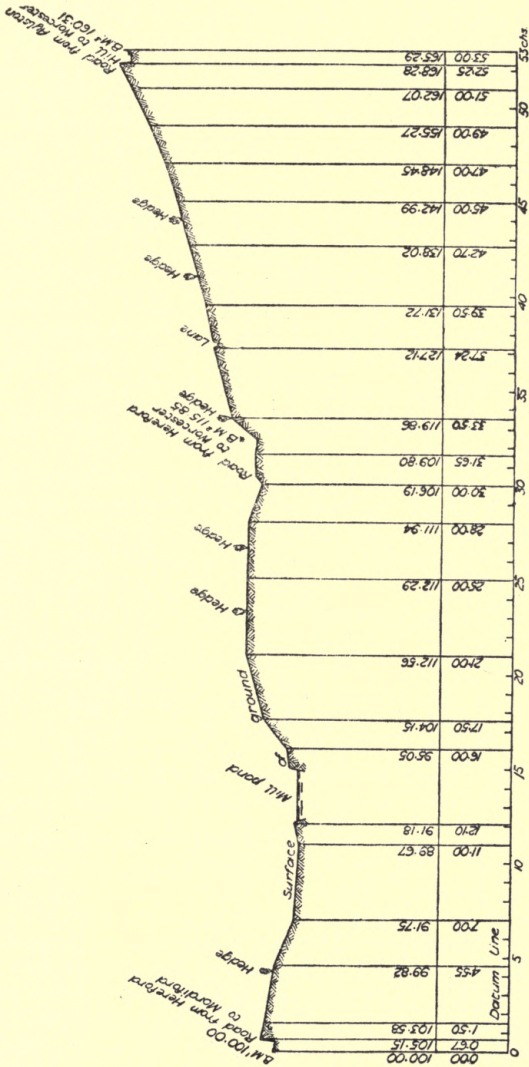

FIG. 139.—Plotting of same.

the road bridge at B and over the river at C. At D a road is crossed on the level. The gradient from D to M is placed so as to give headway for the road bridge at M and will necessitate raising the approaches to the road bridge at E, as shown by the cross section. From M to the terminus the gradient is kept up to give extra headway over an important

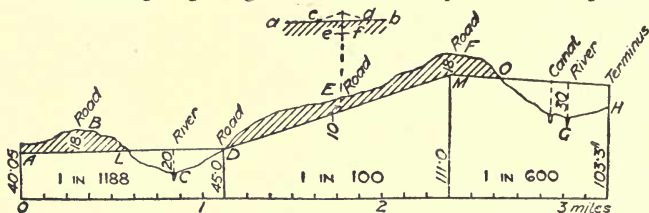

FIG. 140.—Working section of short piece of railway.

river. This will be sufficient to show the general principles that govern the work.

**Keeping the level book.**—The mode of keeping the level book in the examples shown above is known as the **rise and fall system**, and is applicable to all cases, but there is another method of keeping the book used by some surveyors, known

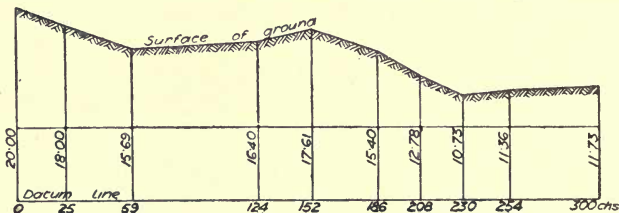

FIG. 141.—Section for comparison of methods of keeping level book.

as the **collimation method**. This is more particularly applicable to level sections where there are many intermediates, such as spot levels in land drainage, etc.; an example of the same section will be given, worked by both methods. Surveyors who use the collimation method speak of the **line of collimation** as an imaginary level line drawn from the back sight reading on the staff through the telescope to the fore sight reading, and this perhaps gives the clearest idea. Fig. 141 is a single section, Fig. 142 is the level book



by rise and fall method, and Fig. 143 the level book by collimation method for the same section.

BACK SIGHT	INTER-MEDIATE	FORE SIGHT	RISE	FALL	REDUCED LEVELS	DISTANCE	TOTAL DISTANCE	REMARKS
4.28					20.00		0	B.M.
	6.28			2.00	18.00		25	
	8.59			2.31	15.69		59	
3.96		7.88	0.71		16.40		124	
	2.75		1.21		17.61		152	
	4.96			2.21	15.40		186	
5.20		7.58		2.62	12.78		208	
	7.25			2.05	10.73		230	
	6.62		0.63		11.36		254	
	6.25		0.37		11.73		300	
13.44		21.71	2.92	11.19	20.00			
		13.44		2.92	11.73			
		8.27		8.27	8.27			

Fig. 142.—Level book for Fig. 141 by "rise and fall" method.

DISTANCE	READINGS	COLLIMATION	REDUCED LEVELS		REMARKS
0	4.28	24.28	20.00		B.M.
25	6.28		18.00		
59	8.59		15.69		
124	7.88		16.40	97.12	
	3.96	20.36	16.40		
152	2.75		17.61		
186	4.96		15.40		
208	7.58		12.78	81.44	
	5.20	17.98	12.78		
230	7.25		10.73		
254	6.62		11.36		
300	6.25		11.73	71.92	
	71.60		178.88	250.48	
				178.88	
				71.60	

Fig. 143.—Level book for Fig. 141 by "collimation" method.

**Telemetry.**—The optical measurement of distances, or **telemetry**, is extremely useful in connection with levelling. Every schoolboy is aware that when he views distant objects

through a telescope, while they are apparently brought nearer, they still appear to vary in size according to their distance. All that is required to convert an ordinary telescope, whether independent or connected with a level or theodolite, into a telemeter, is to fix two additional wires upon the diaphragm in such a position that when the staff is 100 feet away they shall appear exactly a foot apart, then for 50 feet they will appear to be separated by five-tenths of a foot, 30 feet by three-tenths, 120 feet by one foot and two-tenths, and so on.

Upon the Continent, where the metric system is in use, this mode of measuring distances is extensively practised, with a very considerable saving of time and labour. The telescope is arranged with three horizontal wires, one of them central, and the others indicating a space equal to *two* metres upon the

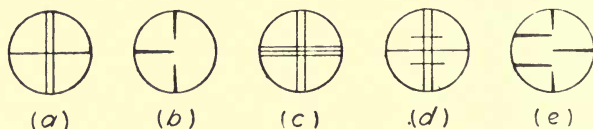

FIG. 144.—A, Ordinary webs in a level; B, stadia points in a level; C, extra webs for telemetry; D, lines engraved on glass diaphragm; E, stadia points for telemetry.

staff when at 100 metres distance. The staff is marked with metres and centimetres, but of *double* size, *i.e.* 2 metres is marked 1 metre, 40 centimetres as 20, etc.; then when the telescope is set level the top reading minus the bottom reading, multiplied by 100, gives the distance, and the top reading plus the bottom reading gives the level. For example, if the top reading be 1.69, and the bottom be 0.83, the distance will be  $(1.69 - 0.83) \times 100 = 86$  metres, and the level will be  $1.69 + 0.83 = 2.52$  metres; the middle wire reads 1.26, and this, being doubled on account of the enlarged divisions, will prove a check upon the latter figures.

The webs for ordinary use in a level are shown in Fig. 144A, and stadia points of platinum-iridium, as in Fig. 144B, are sometimes substituted for them. For purposes of telemetry, extra horizontal spider webs may be put in the diaphragm, as Fig. 144C, or a glass diaphragm with lines engraved on it, as Fig. 144D, or platinum-iridium stadia points, as Fig. 144E.

**QUESTIONS ON CHAPTER XX.**

1. In plotting a main section of levelling how are cross sections indicated?
2. Show by sketches how the difference between cutting and embankment is indicated on a plan.
3. Explain the collimation method of keeping a level book.
4. What do you understand by telemetry ; how is it carried out and what are its advantages?
5. Explain how the cross wires of a level are adjusted in the telescope. What substitutes can be used for spider web?
6. What are "stadia points" in a level? Give an example of their use.

## CHAPTER XXI.

Levels of building plots—Equal vertical and horizontal scales—Spot levels—Building plot with sections—Building plot with sections and contour lines—Levelling with barometer—Surveyors' compensated aneroid barometer and method of using.

**Levels of building plots.**—Architects frequently require the levels of building plots taken so that they may design the building to suit the ground, or determine what alteration must be made to the ground to suit the building. As their

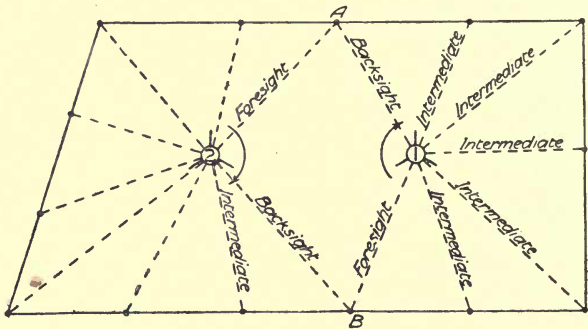

FIG. 145.—Plan of plot showing method of taking levels from two points.

drawings are generally to the scale of  $\frac{1}{8}$  in. to 1 ft. that will be the scale, both vertical and horizontal, to which the levels of building sites should be plotted.

Fig. 145 shows a very simple case, where the whole of the readings can be taken from two points, marked respectively 1 and 2. The instrument being set up at 1 and adjusted, a reading is taken to the staff held on the boundary at A and entered as a back-sight. Then at any required intervals,

measured and recorded, intermediate sights are taken, and the last entry sighting to B before shifting the instrument to

Levels of building plot.

BACK SIGHT	INTER-MEDIATE	FORE SIGHT	RISE	FALL	REDUCED LEVELS	DISTANCE	TOTAL DISTANCE	REMARKS
	1'66				20'00		A	
	2'25			0'59	19'41		10	
	2'79			0'54	18'87		20	
	3'47			0'68	18'19		30	
	4'04			0'57	17'62		40	
	4'99			0'95	16'67		B 50	
	5'54			0'55	16'12		20	
	6'36			0'82	15'30		40	
	7'26			0'90	14'40		60	
	8'35			1'09	13'31		C 80'9"	
	7'25		1'10		14'41		25	
	6'48		0'77		15'18		D. 50	
	4'45		2'03		17'21		40	
	1'66		2'79		20'00		A	
			<u>6'69</u>	<u>6'69</u>				

FIG. 146.—Levels of building plot.

the new position is entered as a fore-sight, which becomes the back-sight when the instrument is set up at 2.

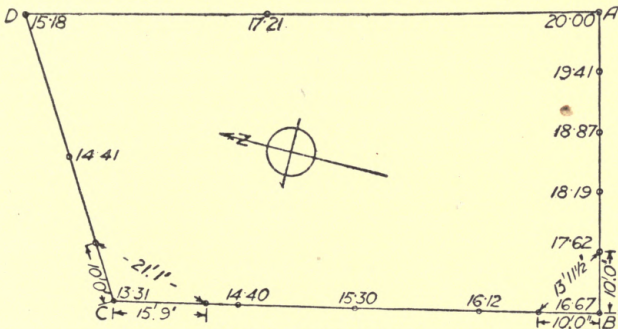

FIG. 146A.—Plan of same.

Fig. 146 gives the copy of the level book with sketch and Fig. 146A the plotting of the plan of a site where one position

of the level was sufficient, and there was therefore only a single collimation line for the whole survey.

**Spot levels.**—When the levels are marked upon the plan, they are called **spot levels**, and this applies also to random levels taken anywhere about a plan so long as they can be located with sufficient accuracy to be suitable for the purpose intended. They are used when a section is not required to be drawn, as in many cases of land drainage, etc. From the spot levels a section can of course be drawn in any direction, the distances being scaled from plan and the levels used as ordinates.

Fig. 147 shows the plan of a building plot with measurements and levels marked on. A section is also given along each boundary, and this must always be drawn as seen when facing the side, to be of any use in connection with the design of the building.

Fig. 148 shows the same plot contoured from the sections just drawn with the addition of levels on the diagonals. The verticals being marked on the sections at every 1 ft. difference of level, the points are transferred to the plan, and a line drawn through all those points indicating the same level.

**Levelling with barometer.**—In hilly countries another instrument is sometimes used for approximate levelling, viz. the **aneroid barometer**, invented by M. Vidi in 1844.

The ordinary barometer contains a glass tube, closed at the top, about 32 inches long with a column of mercury in it, the lower end of the tube being turned up and enlarged to form a reservoir. The top end of the tube being closed, and having a vacuum in it, the mercury is supported by the pressure of the atmosphere upon its surface in the reservoir, and as the pressure varies by atmospheric disturbances so the top of the mercurial column varies in height, which is registered against a scale of inches and tenths. The mercury would fall in the tube if this instrument were carried up a hill, because there would be less weight of atmosphere above to balance the mercury, but it would not be possible to carry it about without extreme care, as the mercury would hammer the top of the tube off.

In levelling with a mercurial barometer the approximate difference in level in feet is given by the formula

$$\frac{H-h}{H+h} \times 55761 \left\{ \begin{array}{l} +117 \text{ for each degree } \frac{1}{2}(T+t) \text{ exceeds } 60, \\ -117 \quad \text{,,} \quad \text{,,} \quad \text{,,} \quad \text{falls short of } 60, \end{array} \right.$$

where  $H$  = height of barometer at lower station,  $h$  = height of barometer at upper station,  $T$  = temperature in  $F^\circ$  at lower station,  $t$  = temperature at upper station.

The aneroid barometer contains no mercury or other liquid, and, being small, is specially adapted for portable use. The principle of it is that two concentrically corrugated discs are fixed together inside by their edges, so that the pressure of the air outside them may compress them or allow them to expand. When carried to a higher level the pressure is reduced, the plates separate more and the movement is indicated by a pointer attached by gearing to the moving plate.

Fig. 149 shows a surveyor's aneroid compensated to allow for changes of temperature. The face is marked with a fixed scale of inches and tenths and half-tenths to which the pointer is adjusted at sea level. Outside this it has a scale indicating feet altitude from 0 up to 8000, or when employed for mining purposes indicating from 3000 ft. below to 5000 ft. above sea level, or the whole 8000 below. This scale is movable by a rack and pinion inside the ring-handle, so that it can be adjusted to zero at the bottom of any ascent.

In going up a hill, the difference of level from the starting point is given, but not the height above Ordnance datum; it is not possible to adjust it to any such standard. In order to read the indications clearly, the barometer is encircled by a ring, to which is attached a fine pointer and a magnifying glass, so that it can be placed exactly over the needle. To use the barometer for practical purposes, it is necessary to have two similar instruments, one to remain at the first station all day so that its fluctuations can be recorded, say, every half-hour; the other to be taken by the surveyor to register his altitudes. He enters the time of each observation so that when he returns he is able to correct his reading according to the variations in the atmospheric pressure which have occurred throughout the day, which are presumed to have occurred also at the various positions which the surveyor reached, but which he would not be cognisant of unless he had the stationary barometer to check by. At a temperature of  $55^\circ F$ . the mercurial barometer falls about  $\frac{1}{100}$  inch for each 10 ft. rise in position, and by interpolation the aneroid barometer can be read to a difference of level of 5 ft. Upon several trials of the

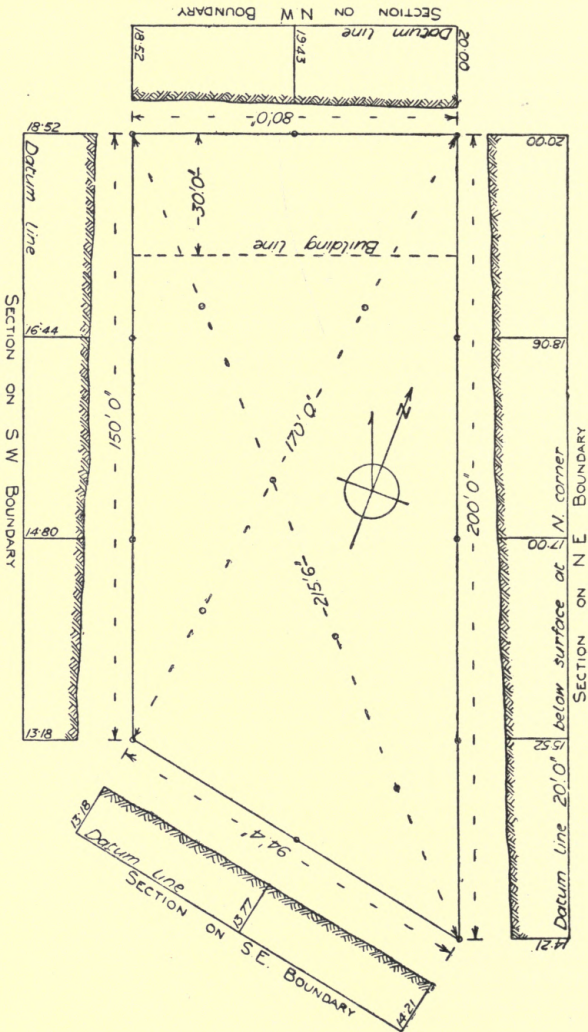

FIG. 147.—Plan of building plot with sections plotted from level book.



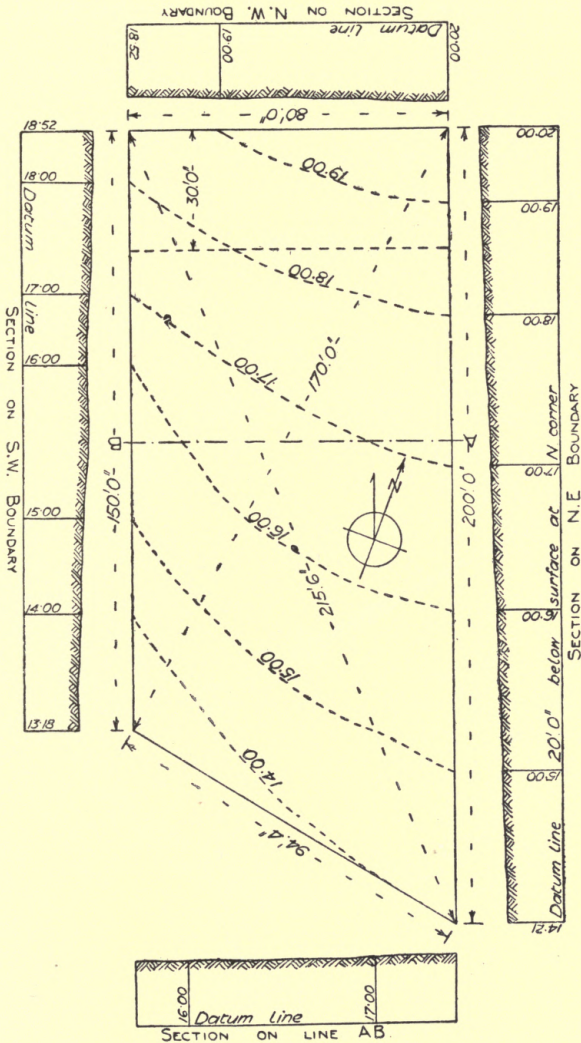

Fig. 148.—Plan of building plot with contour lines plotted from sections.

instrument against actual levels the author has found the indications reliable within about 3 ft.

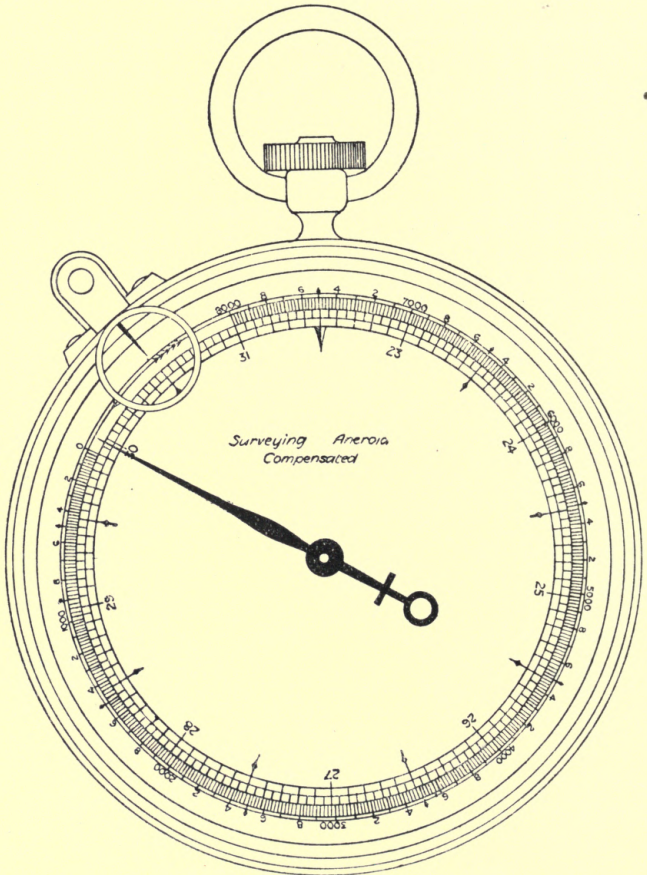

FIG. 149.—Aneroid barometer.

**QUESTIONS ON CHAPTER XXI.**

1. Describe how you would survey and level a simple building site on falling ground.
2. What are "spot levels" and when are they used?
3. Describe the construction and use of an aneroid barometer.
4. What causes the rise and fall of a barometer when kept at one station?
5. How much does the mercurial barometer fall for each 10 ft. rise in position?
6. Explain how contour lines can be plotted from sections taken through a building plot?

## CHAPTER XXII.

Principles of angular measurement—Old definition of an angle—Trigonometrical definition—Instruments for setting off or measuring angles—Semicircular and rectangular protractors—Circular protractor with pricker arm and vernier—Scale of chords.

**Angular measurement**—Before entering upon the use of instruments for angular measurement, it will be desirable to say a few words about angles.

The theodolite is an instrument by which vertical and horizontal angles can be measured with great accuracy, theodolite surveying being distinguished from chain surveying by the measurement of angles instead of tie lines, although all theodolite work involves some amount of chaining, or measuring distances, even if it is only a base line to start the work.

Trigonometry, or three-angle measurement, is the science by which the complete dimensions of triangles may be calculated from certain given portions, viz. three sides, two sides and the included angle, or one side and two angles. It is essential to understand trigonometry for advanced work, but the author's little book on *Practical Trigonometry*<sup>1</sup> will be found to deal with the subject fully enough for actual use. At present it will be sufficient to consider the general principles upon which angular measurement depends.

An **angle** is the opening made by two straight lines which meet together in a point (Fig. 150), or would do if produced (Fig. 151), and in trigonometry an angle may be described as the opening between two radii. The first thing to observe is that the angle is quite independent of the length of the lines, and any given length may, therefore, be assumed for them in dealing with the properties of an angle. Take two lines, say

<sup>1</sup> *Practical Trigonometry for Engineers, Architects and Surveyors.* (Whittaker, 2s. 6d. net.)

1 inch long, meeting at a point, as Fig. 152, one of them fixed horizontally and the other hinged at the meeting point, being free to revolve round the point as a centre. These lines can be closed together or opened to any extent, and if in opening them the movement is continued right round until the starting point is again reached, the outer end of the moving line will have described a circle. The line can readily be imagined as stopping at any intermediate position, and wherever that may be a definite angle will be formed. If the movement is stopped

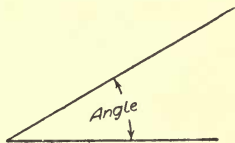

FIG. 150.

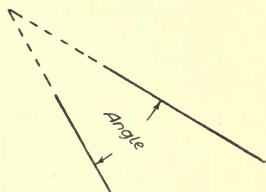

FIG. 151.

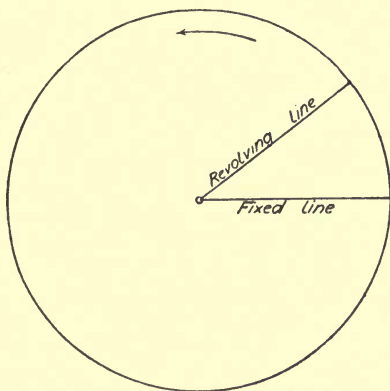

FIG. 152.

FIGS. 150 to 152.—Angles.

ninety times at equal distances from the horizontal base line to a vertical position at right angles to the base line, there will have been marked 90 spaces, each of which will be called 1 **degree**, and continuing the movement of the line through the remainder of the circle, with stops of equal duration, there will be marked in all 360 degrees. This is the substance of angular measurement.

Any other interval might have been taken, giving a greater or less total number of divisions; for instance, the French use **grades** or 100 divisions in a right angle, but the accepted English standard or unit of 1 degree is just large enough to make 90 divisions in a quadrant, or 360 in a whole circle. If longer lines were taken the circle would be larger, and the

divisions, if marked on its circumference, would be larger, but the respective inclinations would be the same for equal angles, that is, angles containing the same number of degrees.

In circular measurement an angle of 180 degrees may be spoken of, which is simply *the space above or below any straight line with regard to a given point in the line*. An angle of 400 or more degrees may be talked about, which is more than a complete revolution of the line, and the meaning is perfectly clear when the angle is looked upon as being formed by a moving radius, but would be unintelligible by Euclid's definition.

In order to allow of very exact measurement, a degree is subdivided into 60 parts, called **minutes**, and these again may each be subdivided into 60 parts, called **seconds**, so that a second is the 3600th part of a degree, or the 1,296,000th part of a complete circle. By a further subdivision into thirds, 60 of which equal one second, very minute divisions for astronomical purposes are obtained, a "third" being approximately equal to one 80-millionth part of a circle, but astronomers usually express angles less than one second as decimals of a second. It is interesting, and possibly useful, to note that 1 minute of arc equals 18 inches at a distance, or radius, of one mile.

**Protractors.**—In order to save the trouble of dividing a circle every time it is desired to measure an angle, certain scales are provided, the commonest of which is a semi-circular protractor, with the edge marked off into degrees as shown in Fig. 153. These degrees are numbered from the base line in both directions, so that an angle opening either to the right hand or left hand may be set off or measured.

Another form of the instrument is the ivory or boxwood rectangle shown in the same diagram, and the relative position of these two instruments with the divided circle shows exactly the method upon which they are constructed.

An improved form of the protractor is a complete circle, which in its most complete form carries an arm with a pricker to mark off any required angles, having also a special scale called a vernier, for estimating minute divisions, which will be explained in connection with the theodolite.

**Scale of chords.**—There is still another way to measure an angle, and that is by a **scale of chords**. This, being a plain straight scale, can be marked in any narrow space upon another

scale, but it is a little more trouble to use. If any circle be drawn and the degrees marked upon it, it will be found that

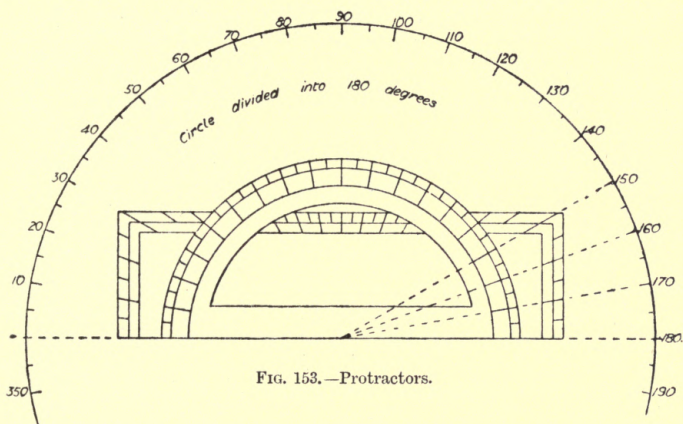

FIG. 153.—Protractors.

the distance from 0 to  $60^\circ$ , measured in a straight line, will be exactly equal to the distance from the centre to the circum-

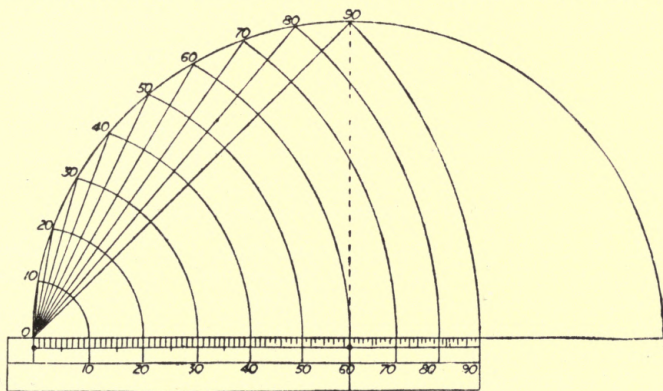

FIG. 154.—Scale of chords.

ference, or in other words, the chord of  $60^\circ$  is equal to radius. This holds good for any size of circle, because as the radius

increases or decreases, so does the chord, and it is a very important property, as will be seen when the mode of using the scale of chords is explained.

The above diagram (Fig. 154) shows the construction of this scale. If a quarter of a circle be drawn and the degrees marked off, lines may be drawn from the zero point to each degree; these will represent chords of the various arcs. The respective lengths of these chords may be transferred to one line and numbered consecutively from zero, making an ordinary scale of chords. Now it will be seen at once that if we have part of a circle of the same radius as the one from which the scale was set off, any number of degrees can be marked upon it by taking the distance off the scale and applying it to the circumference as a chord. Remembering that the chord of  $60^\circ$  is equal to radius, the size of the circle employed in constructing the scale can always be found by taking the distance from 0 to 60.

To set off an angle of  $37^\circ$  from point A (Fig. 155), take the

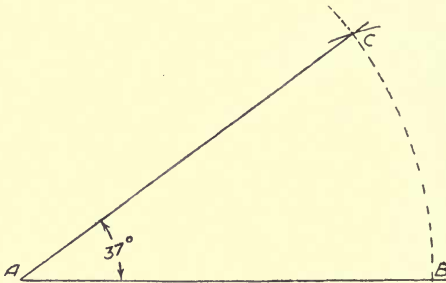

FIG. 155.—Setting off angle by scale of chords.

scale of chords, open the compasses from 0 to 60, and strike the arc BC. Then open the compasses from 0 to 37 and from B strike an arc with this radius to intersect the previous arc, and give point C, when the angle BAC will be 37 degrees. To measure an angle already drawn, strike an arc with radius 0 to 60, take the chord of the arc upon the angle and apply it to the scale of chords to ascertain the angle.

In the best scales of chords a brass peg is let in at 0 and at 60 to avoid the damage resulting from compass points being continually applied.



QUESTIONS ON CHAPTER XXII.

1. Draw an angle  $BAC=180^\circ$ , and state how many right angles there are in a circle.

2. Find how many degrees, minutes, and seconds there are in  $1\frac{3}{4}$  right angles, and how many seconds there are in  $35^\circ 19' 53''$ . (Ans.:  $128^\circ 34' 17\frac{1}{2}''$ . 127193.)

3. State in what other way you could define an angle of  $540^\circ$ , and find how many degrees and decimals there are in 4139 seconds. (Ans.: 6 right angles. 1.14972.)

4. If the distance from 0 to 60 on a scale of chords be 3 inches, what will be the length of a chord of 45 degrees? (Ans.: 2.296 in.)

5. In a right-angled triangle one acute angle measures  $47^\circ 15' 23''$ ; what does the other measure? (Ans.:  $42^\circ 44' 37''$ .)

6. In two triangular fields of different size, but whose angles at corresponding extremities of the base are equal, the base and perpendicular of the smaller one are respectively 13.40 and 6.17, and the base of the larger is 19.21; what is its perpendicular, and what is the area of each triangle in a. r. p.? (Ans.:  $8.84\frac{1}{2}$ . 4 a. 0 r.  $21\frac{1}{2}$  p. 8 a. 1 r.  $39\frac{1}{4}$  p.)

## CHAPTER XXIII.

Construction and reading of diagonal scale—Construction and reading of vernier scale—Construction and reading of verniers on theodolite—Construction and adjustment of box sextant—Method of using same—Construction and use of plane table.

**Diagonal scales.**—Now that we are considering how very accurate measurements may be made, it may be as well to show how minute sub-divisions on a straight line may be obtained by what is called a **diagonal scale**.

Suppose a scale is required upon which hundredths of a unit may be measured. Divide the given line into units by the application of an ordinary scale, draw ten other parallel lines, say  $\frac{1}{8}$  inch apart, as in Fig. 156; divide the first unit

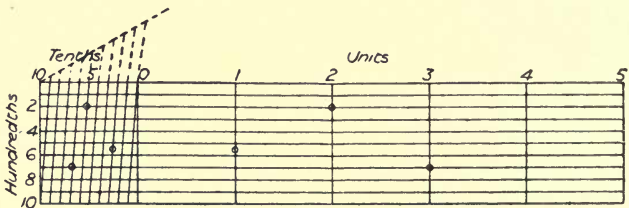

FIG. 156.—Diagonal scale.

into tenths by the method shown, then, with the tee and set-square, project all the unit divisions through to the bottom line and the tenth divisions on the bottom line only. Then with the tee-square shifted so that the set-square will join the end of the first tenth on the top line with the beginning of it on the bottom line draw parallel diagonal lines. As a diagonal line progresses one-tenth of a unit in passing over the ten spaces of the depth of scale, it will progress only one-tenth of a tenth, or one-hundredth of a unit from one line

to the next. The lengths marked by the dots on three of the horizontal lines shown in Fig. 156 will be respectively 2.52, 1.255, and 3.67.

**Verniers.**—The same minuteness of sub-division may be obtained by the use of a **vernier**, which is a small movable scale placed against a longer one called the primary scale. It is shown in Fig. 157 for the reading of hundredths of an

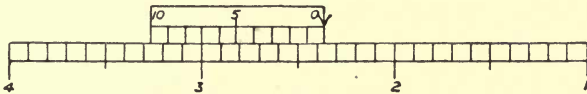

FIG. 157.—Vernier scale.

inch, and is similar to that attached to a standard mercurial barometer.

The principle is as follows: If the vernier is desired to give tenths of the smaller divisions on the primary scale, nine of these divisions will be taken and the length divided into ten equal parts. Then each of the vernier divisions will be one-tenth less than each of the primary divisions, and if, say, the third division on the vernier coincides with a division on the primary scale, the commencement of the vernier will be three-tenths of a division in advance of the nearest division on the primary scale. With the vernier in the position shown, it will be seen that the arrow on the vernier is in advance of  $2\frac{3}{10}$  or 2.3 on the primary scale, and, looking along the

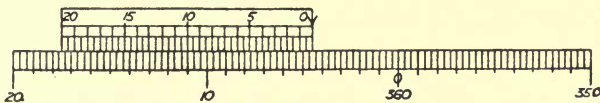

FIG. 158.—Theodolite vernier.

vernier, the seventh division is found to coincide with a division on the primary scale, so that the reading becomes 2.37 in. If two intermediate lines on the vernier are equally upon the point of coinciding with lines on the primary scale it will add 0.005 to the reading from the lower division, and so on, by estimation for any other position.

**Theodolite vernier.**—The primary scale or horizontal circle of a 6-in. theodolite is usually divided to degrees and thirds of a degree, as in Fig. 158, so that the arrow of the

vernier reads to 20 minutes of arc, but the vernier, having 39 of these divisions sub-divided into 40 equal parts, enables half minutes, or intervals of 30 seconds, to be read. The reading shown on the figure is  $4^{\circ} 30'$ .

It will be observed that the scale on a theodolite is marked from right to left, because the eyepiece of the telescope is always turned that way, the object-glass travelling from left to right between the objects observed.

In using the theodolite for horizontal, or azimuthal angles, as they are sometimes called, the angle through which the telescope has been turned is marked by the position of the vernier zero, the circle being a fixture. When the arrow coincides with a division on the circle, the angle is read off as

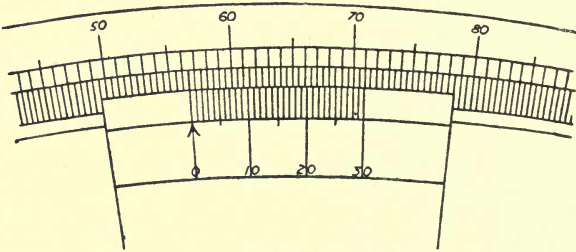

FIG. 159.—Box-sextant vernier.

if from an ordinary protractor, being exactly so many degrees, or degrees and 20 minutes or 40 minutes, or degrees and 30 minutes, according to the mode in which the circle is divided. The odd minutes and seconds are read off by a microscope placed over the vernier, search being made for the lines which most nearly coincide with the divisions of the primary circle.

The **vernier on a box-sextant** is a flat arc of about 150 degrees, commencing at 5 degrees below zero, with a radius of about 2 inches, and divided into degrees and half degrees. The vernier has 29 of these divisions divided into 30 equal parts, so that single minutes may be read from it by means of a magnifying glass. Fig. 159 shows a highly-magnified view of this vernier and part of the primary arc, the reading indicated being  $56^{\circ} 32'$ .

As the box-sextant is the simplest instrument for observing angles, its construction and use will be described next.

**Construction and use of box-sextant.**—The general appearance of a box-sextant is as shown in Fig. 160, and an enlarged diagrammatic plan of it is shown in Fig. 161. It is about 3 in. in diameter, and is made with or without a telescope; it is used for measuring approximately the angle between any two lines by observing station poles at their extremities from the point of intersection. In Fig. 161, A is the sight-hole, B is the horizon glass, a fixed mirror having one half silvered and the other half plain; C is the index glass, a mirror attached to the same pivot as the vernier arm

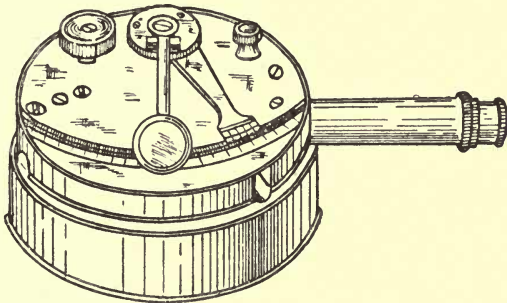

FIG. 160.—General view of box-sextant.

D. The side of the case is open to admit rays of light from the observed objects.

In making an observation of the angle formed by lines to two poles, one pole would be seen through the clear part of mirror B, and at the same time rays of light from the other pole would fall on to mirror C, which would be moved until the pole is reflected on the silvered part of mirror B, exactly in line, vertically, with the pole seen by direct vision, then the angle between the two poles would be indicated by the vernier. Take the case of a single pole, then the angle indicated should be zero, but whether it would actually be so depends upon circumstances, which may be explained as follows:

Suppose the pole to be fixed at E, which is extremely close,

it will be found that the arrow on the vernier arm falls short of the zero of the scale owing to what may be called the

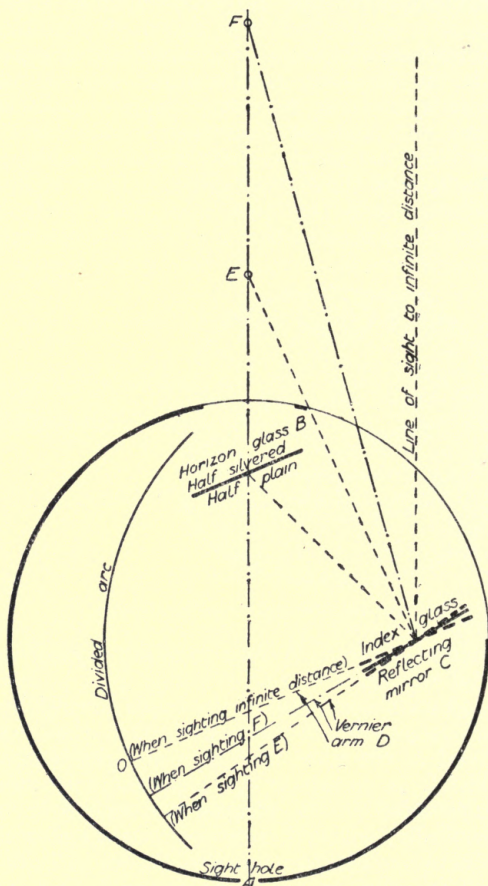

FIG. 161.—Diagram showing principle of box sextant.

width of the base line of the instrument. If the pole is placed farther off, as at F, the rays of light from the pole will take the course of the stroke-and-dot line, and the vernier

arm will require to be shifted nearer the zero of the scale. After a distance of two chains between the pole and sextant is reached, the rays of light from the pole to B and C are so nearly parallel that the error is under one minute, and the instrument can be used under such conditions without difficulty occurring by reason of error. To adjust the box-sextant, the smoked glass slide should be drawn over the eye piece, and then, if the sun is sighted, it should appear as a perfect sphere when the vernier is at zero, in whatever position the sextant may be held. When reading the angle formed by the lines from two stations, the nearer station should be sighted through the plain glass, which may necessitate holding the instrument upside down. When the angle to be read between two stations exceeds  $90^\circ$ , an intermediate station should be fixed and the angle taken in two parts, as in viewing large angles the mirror C is turned round to such an extent that its own reflection and that of the image upon it is viewed almost edgewise in the mirror B.

It should be noted that the box-sextant only indicates angles in the plane of the instrument, so that if one object sighted is at a lower level than the other, the angle read will be the direct angle between them, and not the horizontal angle, as given by a theodolite.

**The plane table.**—The plane table is principally used as an aid in rough military sketching, but it may be occasionally useful for an approximate general survey. It consists of a small drawing board fixed upon a tripod, so that it can be levelled and clamped in any given position. A sheet of drawing paper is pinned upon it, on which the directions of any prominent objects may be obtained by means of a loose sighting-arm or sight-rule, called an *alidade*, which may be placed in any position on the paper. The base of the alidade may conveniently contain a rectangular compass box, *i.e.* with a needle having a scale of degrees and half or thirds of degrees extending say 5 degrees each side of North; then turning the instrument so that the needle points exactly to zero, a line may be drawn alongside, which represents the direction of magnetic north. The sides of the base may be divided into convenient scales, such as 88 feet to 1 inch, 10 chains to 1 inch, or 6 inches to 1 mile.

In using a plane table, it is set up at a convenient point

facing the part to be surveyed, the paper fixed upon the board and the direction of magnetic north determined. Then the distance to some other point facing the survey is measured to serve as a base line, the direction sighted and ruled on the paper by the right-hand edge of the sighting rule, and the length cut off according to the scale that is adopted. Then the prominent features of the part to be surveyed are sighted

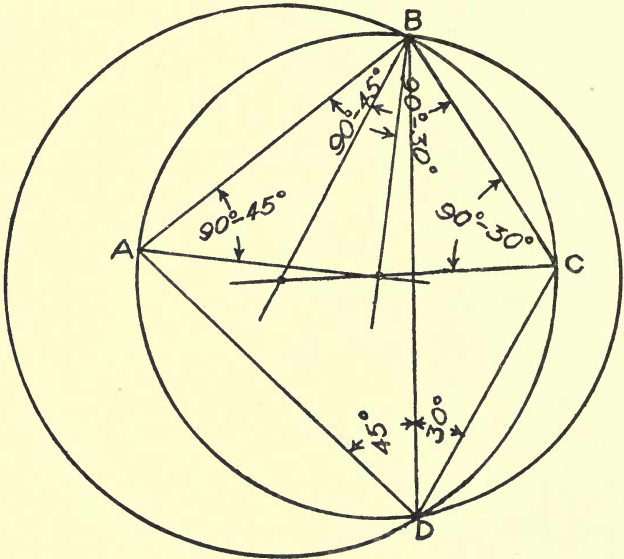

FIG. 161A.—Three-point problem in plane-tableing.

and ruled in from the first station, and either the lines numbered to correspond with a description of the object in the field-book, or the description briefly noted on each line. The plane table is then moved to the other end of the base line and set by the compass mark, so as to be in the same relative position with the meridian, and directions sighted to the same prominent features from the second station and ruled in to intersect with the other lines.

The distinctive points being thus obtained by automatic triangulation upon the paper in their true relative positions,



the other features can be sketched in with a close approximation to accuracy. As in large triangulation surveys, new base lines can be located when necessary, so in plane tabling a new base line can be set up anywhere so long as the ends are observed from both ends of the previous base line. In drawing the lines of direction, it will be found very convenient to insert a needle or a small pin on the point from which the lines radiate as a guide to the rule. Fig. 169, although drawn for another purpose, shows exactly how the intersecting lines from the two ends of the base determine the positions of the principal points of a plane table survey.

The three-point problem in plane tabling is similar to that in hydrographical surveying, viz. locating the position of a point from which the angles made by three given points have been observed. Let A, B, C (Fig. 161A) be the three given points on a map whose angles ADB and BDC, subtended at D, are found to be respectively  $45^\circ$  and  $30^\circ$ . Join AB and set off at each end angles  $= 90 - 45 = 45^\circ$  to give the centre of a circle which will pass through AB and D. Then join BC and set off at each end angles  $= 90 - 30 = 60^\circ$  to give the centre of a circle which will pass through BDC. The common intersection of the circles gives the point D.

### QUESTIONS ON CHAPTER XXIII.

1. Make a diagonal scale to measure inches and hundredths of an inch.
2. Draw about 30 degrees of the arc of a circle 3 in. radius and construct a scale and vernier to read to 10 min.
3. Show by a full-sized sketch the arrangement of a box-sextant and describe how the vernier arm is moved.
4. Sketch a method by which an angle of  $175^\circ$  may be read with a box-sextant.
5. Explain why a box-sextant cannot be used for taking horizontal angles on undulating ground.
6. Give a brief description of the method of surveying known as plane-tabling.

## CHAPTER XXIV.

Construction of theodolite—Primary horizontal circle and verniers—  
Vertical circle and verniers—Setting up and adjusting theodolite—  
Reading verniers—Repeating an angle.

**Construction of theodolite.**—The theodolite consists essentially of a telescope mounted upon bearings by which the object glass can be elevated or depressed, with a vertical axis upon which it can be rotated. Attached to the frame supporting the telescope is a circular base plate containing two, or sometimes three, verniers; and this plate can be rotated on a base attached to the upper parallel plate which is divided round the whole circumference in degrees and half degrees, and sometimes degrees and thirds of degrees. This is called the **primary circle** and enables **horizontal angles** to be measured accurately.

The vernier plate has a clamp and tangent screws so that it can be accurately set in any desired position; and the primary circle has also a separate clamp and tangent screw, so that when the verniers are at zero the telescope can be directed and clamped in any required position.

Some theodolites have the primary circle fixed so that the telescope cannot be set to zero upon the first station, but this is of very little consequence, as the angle is easily obtained by taking the difference of the first and second readings, and some surveyors even consider it an advantage. At any rate, it avoids the constant setting of the vernier to zero and the consequent wear upon the clamp at one spot, which is apt to prevent it from holding firmly.

There is also a **vertical circle** in the transit instruments, or a half circle in the Everest theodolites, divided similarly to the primary circle and attached to the telescope. The frame carries two verniers by which the vertical circle can be read to minutes or half-minutes, and the arm to which the verniers

are fixed is adjustable by tangent screws, so that when the verniers are set to zero the telescope will have the spirit bubble in the centre of its run. The detail of the arrangement varies in different instruments, but there is no difficulty in finding the necessary adjustment. The lower portion of the instrument has two parallel plates and screws similar to the level, and the whole stands upon a substantial tripod. The general arrangement is as shown in Fig. 162.

Some theodolites have a compass between the A frames, so that it may be used as a circumferentor, but it is difficult to read the compass needle in this position, and a better arrangement is to have a long compass needle in a narrow box on the top of the telescope, with about 5 degrees marked on each side of the centre, so that it can be clearly seen, and the telescope can be readily set in the magnetic meridian. If the vernier be set to zero on the primary circle, and the telescope turned and clamped so that the needle is at zero, the verniers may be unclamped and the telescope turned to read the compass bearing on any line.

If facility has been attained in using a level, no serious difficulty will be found in using a theodolite, and considerable practice may be obtained with both instruments in a back garden. As in the level, the parallel plates are first adjusted by the screws, so that they are as nearly parallel as can be seen by the eye; then, all clamps being loosened, the bubbles are placed across and in line with the right hand leg, and the leg adjusted to bring both bubbles central. The plummet is then observed to see how far it is away from the centre over which the instrument is to be fixed, and in what direction. Then the two legs that have not been adjusted are shifted the required amount and direction, and the right-hand leg again adjusted to bring the bubbles central. This is repeated until the plummet is exactly over the required point or station, when the legs are equally and firmly pressed into the ground. Then the first vernier to the left of the eye piece is set approximately with the arrow to zero or 360 by the eye, and adjusted exactly by clamping the vernier plate, looking through the microscope, and turning the tangent screw as required. Then the lower clamp being loose, the bubbles are set over the diagonal pairs of screws, and they are adjusted to bring the bubbles exactly central.

The telescope is now turned to sight the end of the first line, the lower plate clamped and adjusted by its tangent

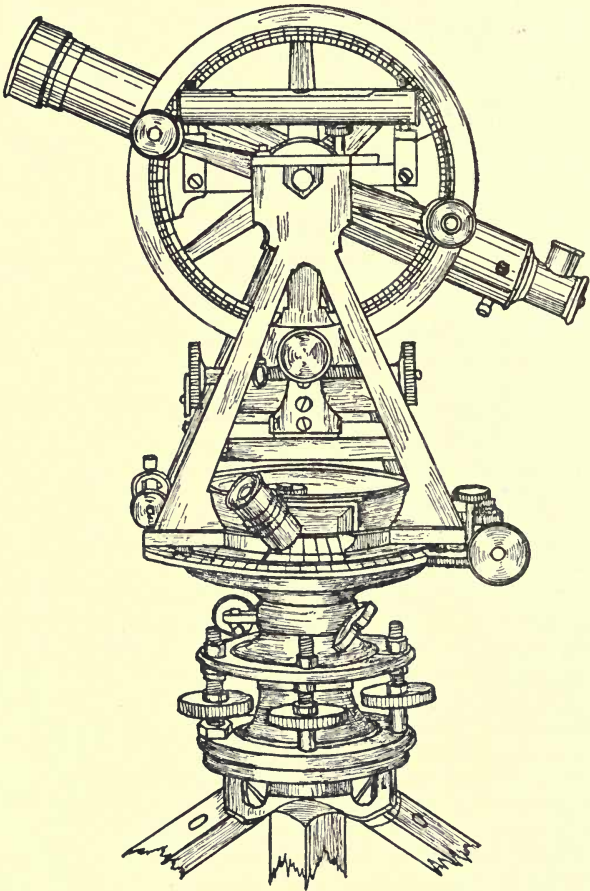

FIG. 162.—General view of theodolite.

screw. The vernier plate is then unclamped and the telescope turned by means of the A frames to read the first angle, the

plate clamped, the telescope adjusted exactly by the vernier tangent screw, and the angle read off by the microscope. In setting the zero, both ends of the vernier should be examined to see that they equally coincide with the divisions on the primary circle, and in reading an angle the adjacent divisions should be observed to see that they are equally displaced, so that the coinciding line may be determined with certainty, and it should then be in the middle of the field of view of the microscope.

In making an open traverse with the theodolite, the instrument is generally set up at the end of the first line and the reverse bearing taken, but in a closed traverse it may be set up at the beginning of the first line and the forward bearing taken; the angle at this station will then be taken

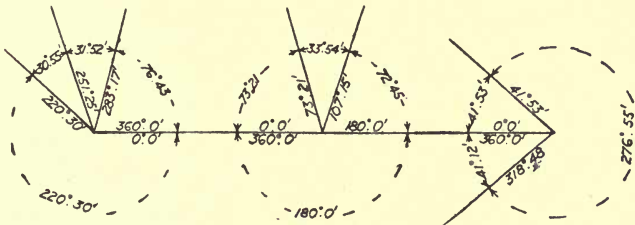

FIG. 163.—Recording angles on chain lines.

between the first line and the last line. When the theodolite is used as an accessory to the chaining, the angles are recorded upon a plan, as shown in Fig. 163.

As all the angles taken with a theodolite are clockwise from the base line, or from the old line to the new line, it often happens that the required angle must be obtained by taking the difference between the observed angles, as shown in Fig. 163. If the telescope is set to zero on the magnetic meridian, all observed angles will be east of north up to 360 degrees. In rough work it is sufficient to read a single vernier, but in careful work the other vernier, or verniers, should be read and the mean taken. In a good instrument the readings will not differ by more than one minute.

When an angle is to be observed with great accuracy, it may be obtained by repeating twice or more, each time keeping the vernier clamped at the observed angle, and

setting back the primary circle, and adjusting it by the tangent screw, so that the telescope is on the first station.

<i>Left-hand vernier</i>		<i>Right-hand vernier</i>	
<i>from 0°. 0'</i>		<i>from 179°. 59'</i>	
<i>1st. reading</i>	84°. 29'	<i>1st. reading</i>	264°. 26'
<i>2nd. "</i>	168°. 56'	<i>2nd. "</i>	348°. 54'
<i>3rd. "</i>	253°. 22'	<i>passing</i>	360°. 0'
<u>6</u>	6 <u>506°. 47'</u>	<i>3rd. reading,</i>	73°. 21'
	<u>84°. 27'. 50'</u>	<u>6</u>	<u>1226°. 40'</u>
	84°. 27'. 50'	<i>(4 times 180°) =</i>	720°. 0'
	84°. 26'. 40'	6	<u>506°. 40'</u>
2	<u>168°. 54'. 30'</u>		<u>84°. 26'. 40'</u>
	<u>84°. 27'. 15'</u>		

FIG. 164.—Repeating angles.

The ordinary method of recording the observations is as shown in Fig. 164, and an abbreviated method is shown in Fig. 165. In the latter the minutes only of the second vernier are entered and the mean of the readings. The entry

	<i>Left-hand vernier</i>	<i>Right-hand vernier</i>	<i>Mean</i>
<i>1st. reading</i>	359°. 60'	- . 59'	359°. 59'. 30"
<i>Last</i>	253°. 22'	- . 21'	<u>253°. 21'. 30"</u>
		<i>Difference</i>	<u>253°. 22' -</u>
	<i>Divided by 3 repetitions</i>		<u>84°. 27'. 20"</u>

FIG. 165.—Another method of repeating angles.

under difference is the mean space passed over by the verniers, viz.: second reading + 360 - first reading.

## QUESTIONS ON CHAPTER XXIV.

1. Make an outline sketch of a theodolite sufficient to indicate the general construction.
2. Describe how a horizontal angle is measured with a theodolite when the stations observed are at different levels.
3. Explain the operation of repeating an angle on the theodolite.

4. What practical uses are made of the vertical circle on a theodolite?
5. How are compass needles attached to theodolites, and what is their use in connection therewith?
6. Describe in detail the operation of setting up a theodolite and reading an angle.

## CHAPTER XXV.

Traversing with theodolite, surveying by the back angle—Field notes of traverse survey—Traversing by angles from magnetic meridian—Triangulation or surveying from two stations—Field Notes of survey from two stations—Observations required for obtaining heights and distances.

**Using the theodolite.**—There are three methods of using the theodolite :

- (a) Traversing or surveying by the back angle ;
- (b) Traversing by taking all angles from the magnetic meridian ;
- (c) Triangulation or surveying from two stations.

	①				
	0.59½	Δ	174°		
	0.00	Δ			
	⑩				
	3.21½	Δ	112°30'		
	0.00	Δ			
	⑨				
	9.50½	Δ	185°		
	0.00	Δ			
	⑧				
	1.61	Δ	70°30'		
	0.00	Δ			
	⑦				
	5.72	Δ	172°30'		
	0.00	Δ			
	⑥				
			161°		
Offsets omitted					
	2.34	Δ			
	0.00	Δ			
	⑤		114°30'		
	4.69	Δ			
	0.00	Δ			
	④		181°		
	5.93	Δ			
	0.00	Δ			
	③		89°		
	2.86½	Δ			
	0.00	Δ			
	②		178°30'		
	1.75½	Reverse Δ bearing			
	0.00	Δ	96°		
	①				at point A
					Sydney Road, Homerton
					24 <sup>th</sup> July 1880
					Traverse Survey with Theodolite
Offsets omitted					

Fig. 166.—Notes for traverse survey with theodolite.



Surveying by the back angle is the method used in railway surveying. It consists chiefly in setting up the instrument at the end of the first line with zero on the primary circle, and

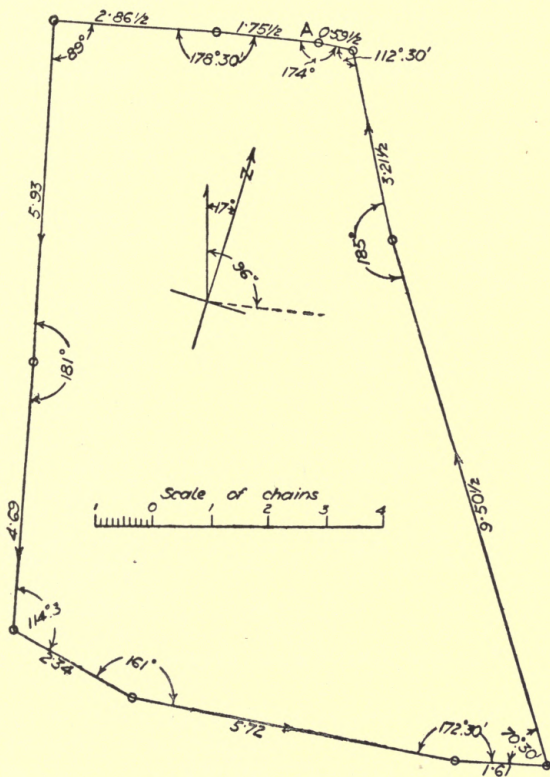

FIG. 167.—Plotting from same.

bringing the telescope to bear upon the station at the commencement of the line, then reading the angle to the station at the end of the second line. The telescope is always supposed to be turned clockwise, but whichever way it is turned the result is the same, as the reading of the angle depends upon

which way round the primary circle is marked. When the angle is less than  $180^\circ$  the new line will run to the left of the old line, and when more than  $180^\circ$  to the right.

**Theodolite traverse survey.**—Fig. 166 gives the field notes of a small theodolite traverse survey in a field at Sydney Road, Homerton, and Fig. 167 the lines. The offsets and boundaries were taken, but are omitted to simplify matters, so

Offsets omitted	11.60	⊙ C	A = $360^\circ$ E = $343^\circ 30'$ D = $313^\circ 30'$ C = $248^\circ 40'$ I = $137^\circ 30'$ H = $95^\circ 5'$ G = $42^\circ$ F = $19^\circ 15'$ Angles at $\Delta B$ from A B = $360^\circ$ I = $342^\circ 20'$ H = $321^\circ 15'$ G = $302^\circ$ F = $245^\circ$ E = $124^\circ 55'$ D = $68^\circ 35'$ C = $19^\circ 35'$ Angles at $\Delta A$ from B AB = 11.90, bearing $132^\circ 45'$ From 2 stations A & B Survey of field with Theodolite
	0.00	⊙ I	
	7.10	⊙ I	
	0.00	⊙ H	
	9.25	⊙ H	
	0.00	⊙ G	
	6.90	⊙ G	
	0.00	⊙ F	
	9.40	⊙ F	
	0.00	⊙ E	
	7.95	⊙ E	
	0.00	⊙ D	
11.10	⊙ D		
0.00	⊙ C		

FIG. 168.—Notes for survey of field with theodolite.

that only the first and last readings on the chain lines are given, and the angle read at each junction is placed where it was read. Any error in alignment or in reading the angle is by this method carried through the remainder of the survey, but in practice every care is taken by reading round to  $360^\circ$  on the original direction, and, if need be, reading the angle again. In railway work three repetitions are made and the mean taken.

To avoid this possibility of carrying on an error, some surveyors recommend the second method of working named above,

taking angles from the magnetic meridian at each station instead of from the previous line; but with ordinary instruments and observers it is difficult to read a bearing closer than half a degree instead of single minutes. For this method of using the instrument a circumferentor or miner's dial is better.

The other method of using the theodolite is **surveying from**

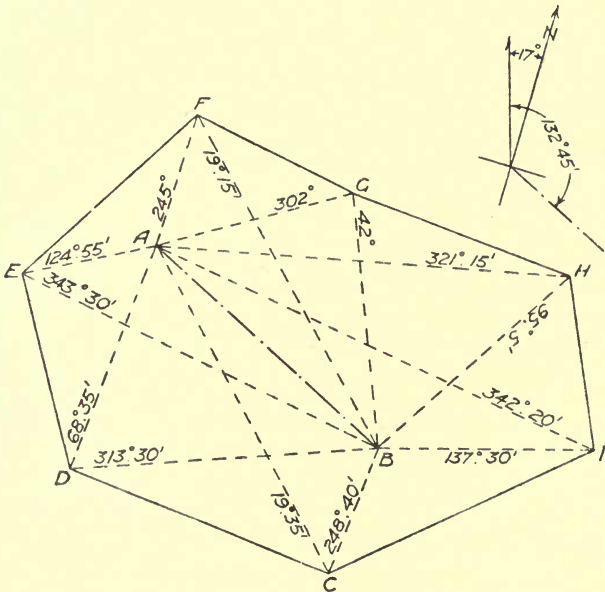

FIG. 169.—Plotting from same.

the two ends of a base line by triangulation. This was the method adopted in the Ordnance Survey of Great Britain. The base line of the Ordnance Survey was a line measured by glass rods in 1794 on Salisbury Plain, about 36,578 feet long, or nearly 7 miles, and from its extremities observations were extended to 250 trigonometrical stations over the whole kingdom. The line of verification, about 41,641 feet, or nearly 8 miles long, measured on the border of Lough Foyle in Ireland,

360 miles from the base, differed from its calculated length by a little over 5 inches.

Fig. 168 gives the field notes for a small theodolite survey from two stations, where the angles were first taken to station poles placed round the field and the chain lines and offsets were afterwards measured. The offsets are omitted in the notes now given. Fig. 169 shows the plotting from the notes,

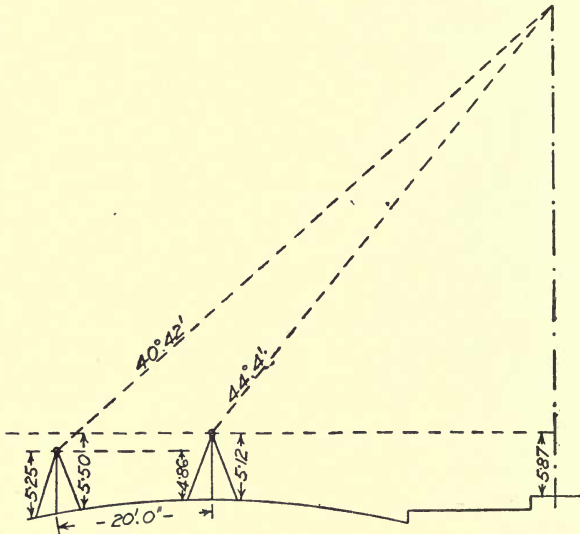

FIG. 170.—Sketch showing necessary observations to find the height of a church finial.

the dotted lines being the lines of sight for its various angles. It will be observed in these field notes that the "trig." stations or places where the theodolite is set up are marked by a small triangle, while the ordinary stations are marked by a circle with a dot in it.

Owing to London smoke, there are great difficulties in the way of theodolite work on a scale of any magnitude without going some distance out. Some time previous to 1847, Mr. Castle, the elder, a celebrated teacher of surveying, made observations at Streatham Common to St. Paul's Cathedral

(5 miles), and to Highgate Church ( $8\frac{3}{4}$  miles), but the writer has found in recent years that only occasional glimpses of St. Paul's Cathedral can be obtained from Highgate Archway ( $4\frac{1}{2}$  miles), although he has on two occasions, between 1890 and 1910, seen the Alexandra Palace from Forest Hill ( $12\frac{1}{2}$  miles) right across London.

In trigonometrical surveying on a large scale, allowance has to be made for the curvature of the earth, but in the ordinary way this is negligible. A knowledge of plane trigonometry, so far as the solution of triangles, is essential to work out the simplest cases when plotting is insufficient, and this may be learnt from the book before mentioned.\* The examples in books and the questions in examinations generally assume ideal conditions, so that when a student attempts practical observations of heights and distances he is perplexed by circumstances for which he has no precedent.

**Typical survey.**—One example only will be given to show the additional measurements that have to be made in practice beyond a simple base line and two angles. A base line was measured carefully with a level staff, and observations taken to the top of the finial of Park Church, Grosvenor Road, London, N., in accordance with Fig. 170, the object being to find the height of the finial above the entrance step.

It is often convenient to use a theodolite as a level when only a few short sights are required as in this case. To do this, the vertical circle is set to zero with the telescope bubble in the centre and the horizontal verniers clamped; the instrument is then used exactly as a level would be used. Vertical angles taken above the zero are known as angles of elevation, and below zero as angles of depression. First reduce the base line to true horizontal length

$$\frac{(5.25 - 4.86) + (5.50 - 5.12)}{2} = 0.385$$

$$\text{True base} = \sqrt{20^2 - 0.385^2} = 19.9963$$

Then find the reduction of base ( $x$ ) due to the prolongation of the angle  $44^\circ 4'$  down to the level of the axis of the lower theodolite, as in Fig. 171.

\* *Practical Trigonometry* (Whittaker & Co.; 2s. 6d net).

Difference of level of the axes of instruments

$$= \frac{(5.50 - 5.25) + (5.12 - 4.86)}{2} = 0.255$$

then

$$x = 0.255 \cot 44^\circ 4' = 0.2634$$

$$\therefore \text{virtual base} = 19.9963 - 0.2634 = 19.7329.$$

Then we have the plane triangles as Fig. 172 to solve, where

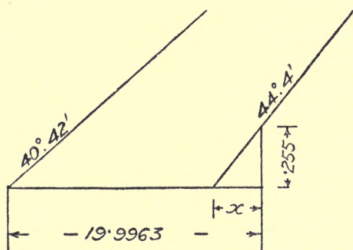

FIG. 171.—Sketch showing method of finding virtual base line.

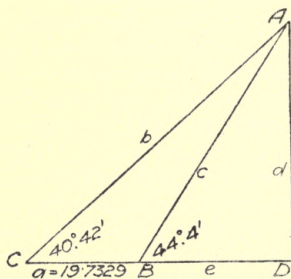

FIG. 172.—Sketch of triangle to be solved by trigonometry.

$C = 40^\circ 42'$ ,  $B = 44^\circ 4'$ ,  $a = 19.7329$ , and the labour of calculation is much reduced by the use of logarithms.

$$\begin{aligned} \log d &= \log a + L \sin C + L \sin B - L \sin (B - C) - 10 \\ &= \log 19.7329 + L \sin 40^\circ 42' + L \sin 44^\circ 4' - \\ &\quad L \sin (44^\circ 4' - 40^\circ 42') - 10 \\ &= 1.2951910 + 9.8143131 + 9.8422939 - 8.7688275 - 10 = \\ &= 2.1829705 \end{aligned}$$

whence  $d = 152.395$  and the required height  $= 152.395 + 5.87 - 0.255 = 158.01$  feet.

In the above calculation the  $-10$  is put in because, in the tables of logarithmic sines, 10 has been added to each group of numbers to keep the value positive, and when there are two plus items and only one minus item, the result would be too great if the 10 were not deducted.

## QUESTIONS ON CHAPTER XXV.

1. Give a sketch showing what is meant by "Surveying by the back angle" or traversing with a theodolite.
2. Why is compass traversing comparatively ineffective with a theodolite? What alternative would you adopt?
3. Describe the general method of triangulation surveys with a theodolite.
4. What is meant by trigonometrical surveying, and what is the particular importance of the base line?
5. Make a sketch showing how the height of a spire may be obtained by observations in one plane.
6. AB is a base line 400 feet long and C a distant point whose height is required above A. The angle  $CAB = 73^\circ 20'$  and  $CBA = 84^\circ 35'$ . The vertical angle to C from A is  $12^\circ 16'$ . Find the height of the point.

## CHAPTER XXVI.

Principles of town surveying—Choice of base lines—Chain or steel tape—Triangulated offsets—Sketching details—Field notes of lines and angles with offsets omitted—Plotting of same—Field notes of one street with measurements—Plotting of same—Connecting chain lines.

**Town surveying.**—For town surveying, or the preparation of plans of land more or less covered by buildings and laid out in streets, the ordinary methods of surveying require some modification to suit the peculiar circumstances of the case. The chief difficulty is that the chain lines are necessarily confined to the streets, and can only in rare cases form part of the general triangulation of the district.

**Choice of base lines.**—Where there is a high street or main thoroughfare through the town, the line through it should be made the base line, and be connected, when possible, with the triangulation outside; but if not, it can still be made the backbone of the survey with the smaller streets branching out from it like ribs. When there is more than one good thoroughfare, each should have a line through it equivalent to a subsidiary base line, and then any streets running through from one main thoroughfare to the other, straight enough for a single chain line, form good checks upon the work by their length without their angles being required. It is seldom that the ordinary station poles can be used, except for a very short period and for the part of the survey which is in immediate progress, so that small iron spikes, or dogs, are driven between the joints of the paving stones, or elsewhere, when it is required to mark a station for future reference. The chain used may be the 4-pole chain, the 50-foot chain, or the 100-foot chain; for a large survey the 100-foot chain or a 100-foot steel tape is best.

The offsets are taken with the tape, using preferably the



side with feet and inches. In narrow and unimportant streets they are simply taken at right angles to the chain as in surveying common field boundaries; but, at all corners and at intervals along important streets, particularly where the frontage line alters, they are taken by triangulation from the chain line. The measurements are taken to the outer boundaries of the various properties, the width of footpaths, forecourts, and other variations, being left until the details are measured.

The field-book for this purpose is kept upon the same principle as for any combined theodolite and chain survey, with the exception that in addition to numbering the lines the names of the streets through which they pass are given, and the angles are marked as taken because the sketches in the field-book make it a rough plan of the survey. As in the field surveys, the main lines are first plotted and afterwards the offsets, so in town surveying the chain lines are first plotted and then the triangulated offsets.

The detailed measurements are generally left until after the main work is done and plotted, but they may be carried on at the same time with another set of assistants. So far the particulars obtained enable a skeleton, or block plan, to be made sufficient for tramway purposes, or any object that involves roadwork only, the plan being a map of the roads and whatever abuts upon them. Town plans, however, are generally expected to show the buildings themselves and any land there may be in the rear. This is all done by tape measurements within the boundary of each property, and is generally a long and tiring job.

This field-book differs from the former, and is generally a small quarto into which each block from the skeleton survey is plotted on a separate page to a scale of 20 to 50 feet to the inch according to the amount of detail that is wanted. Then a sketch of the individual premises is made, and the length of every straight part marked down, together with a sufficient number of diagonal distances to enable the whole to be drawn accurately.

Some prefer the book made of paper ruled in small squares so that the premises may be sketched roughly to scale at the time, but a neat draughtsman will find very little assistance from this, as the best and most expeditious work is done by

# PRACTICAL SURVEYING

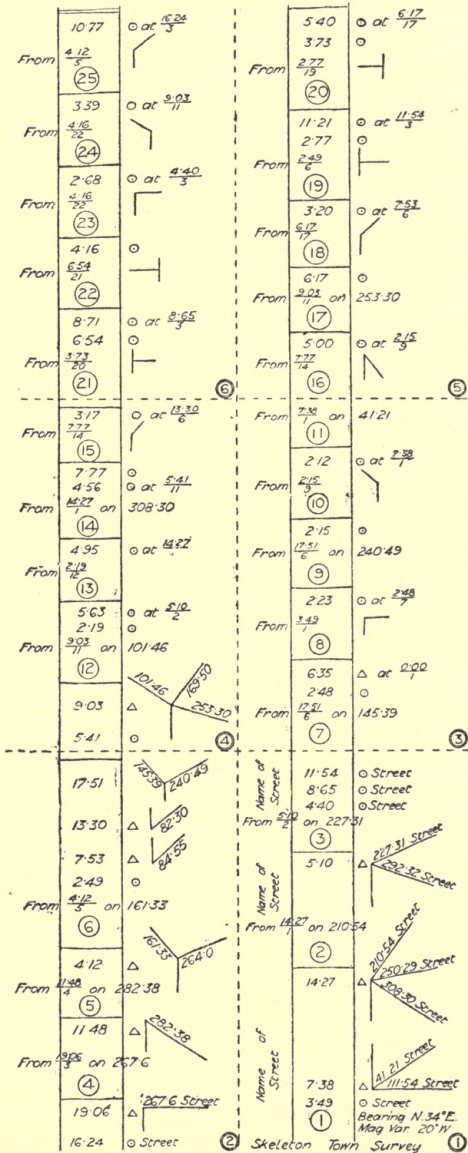

slightly exaggerating all the natural features, making a slight bend more excessive to emphasise its direction and a straight

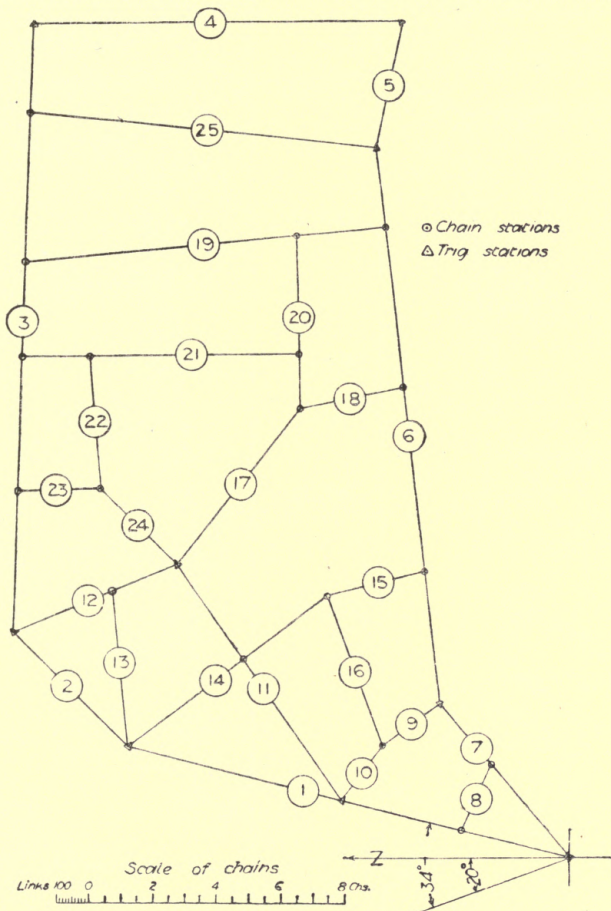

Fig. 173.—Skeleton town survey.

line shorter than its real length because it requires fewer measurements upon it. This is the general procedure, when

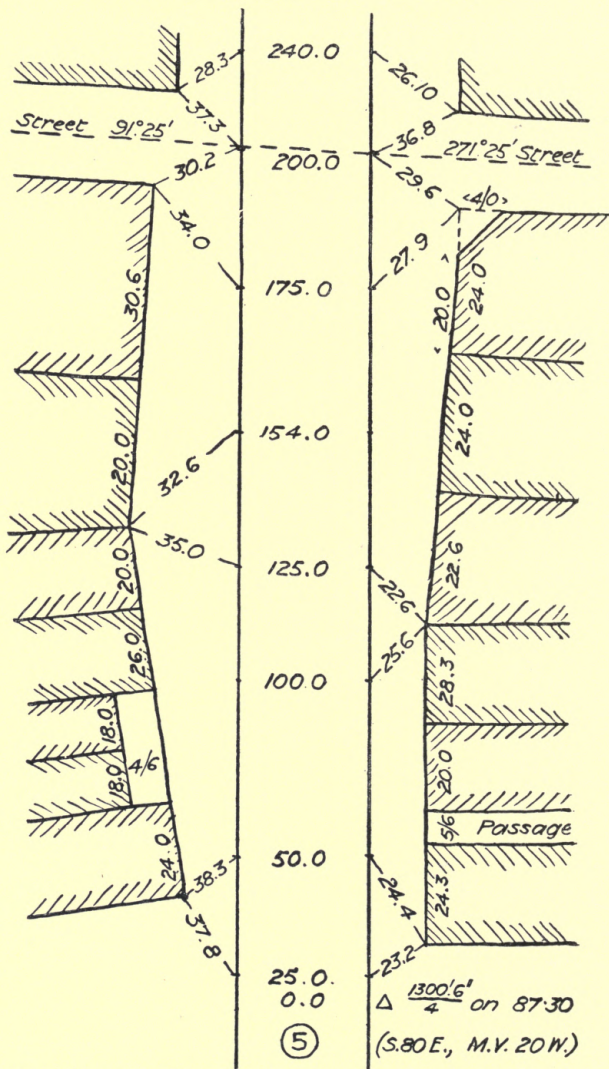

Fig. 174.—Extract from field notes of town survey with 100-foot chain.

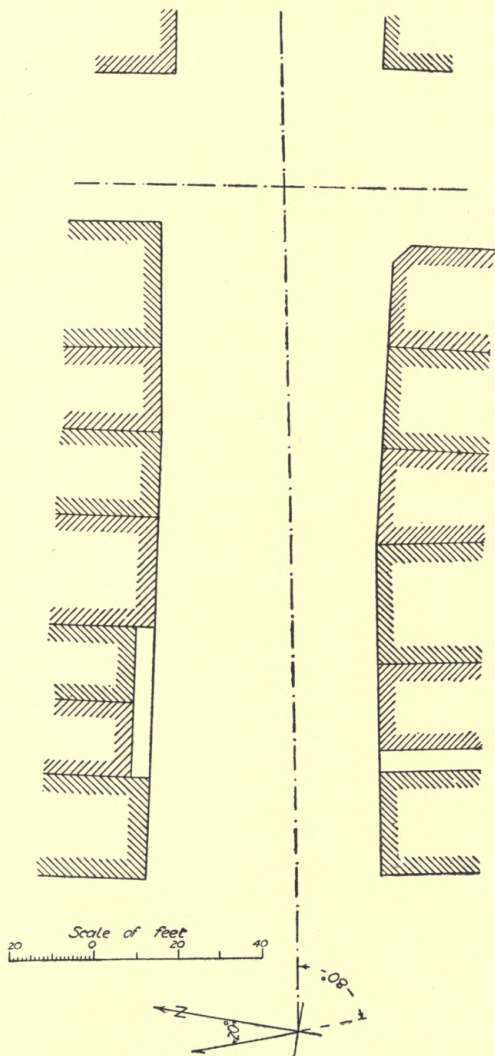

Fig. 175.—Plotting of same.

the scale upon which the plan is ultimately required does not exceed 5 feet to the mile = 88 feet to 1 inch. The common parish map scale of 3 chains to 1 inch is 198 feet to 1 inch or  $26\frac{2}{3}$  inches to 1 mile, nearly corresponding to the Ordnance scale of  $\frac{1}{2500}$  or 25.344 inches to 1 mile.

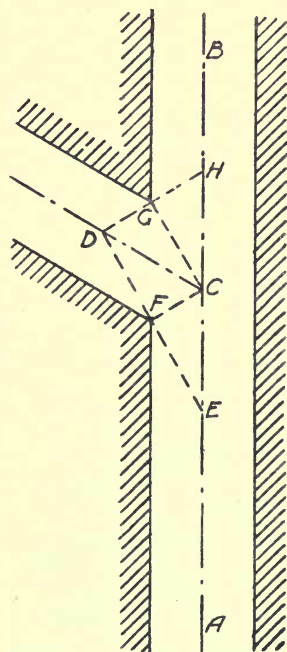

Fig. 176.—Tying junction of streets in chaining.

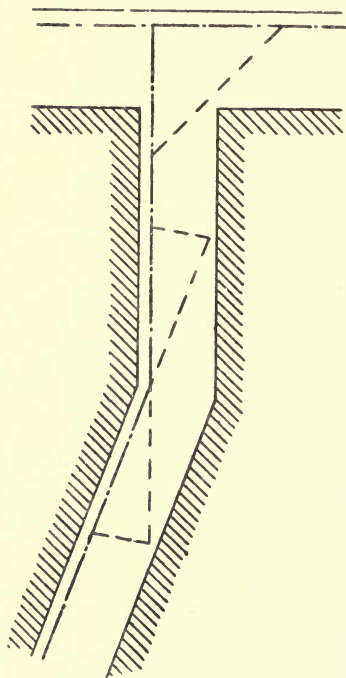

Fig. 177.—Tying bend in street in chaining.

The field notes on p. 186 omit all details and give only the chain lines and angles, which may be looked upon roughly as giving the centre lines of the streets. The plotting of the lines and angles is given in Fig 173.

**Field notes of one street.**—Fig. 174 shows the field notes of one street with the frontage of the various properties, the

plotting of which is given in Fig. 175. Sometimes the bends and junctions of the street have to be tied by chaining only. Figs. 176 and 177 show examples of the methods employed. In Fig. 176 two chain lines, AB and CD, are shown intersecting at C. A point is taken at E and sighted through to D, tangent to the corner of the building at F. Then from D, tangent to G, a line is sighted to H, and the measurements between the letters along each of the dotted lines are taken. If the road is a cross road passing on both sides of the main road, the same set of operations is repeated on the other side of the base line. If a larger survey is being made and a village is included within the area, and a main line does not run through the village, there should be, if possible, a large triangle surrounding the village, within the three corners of which the smaller survey may be made, and to which it may be connected. In Fig. 177 by keeping the chain lines on the side of the street where the salient angles occur, longer ties may be obtained, and the tie triangles may be drawn to twice the scale of the plan to ensure greater accuracy.

### QUESTIONS ON CHAPTER XXVI.

1. What are the general principles of town surveying?
2. Give an illustration of a triangulated offset and state what is its advantage over a common offset.
3. What are double chain lines, and why are they used?
4. How are the stations marked in a town survey when not actually in use for observations?
5. Show by a sketch how the angles of intersecting roads are recorded in a town survey?
6. How may angles be plotted with the greatest accuracy?

## CHAPTER XXVII.

Difference in lay-out of old and modern towns—Available accuracy depending upon scale employed—Double chain lines—Example of field-book—Plotting of same—Tape surveys—Sketch of back premises with measurements—Plotting of same.

**Old and modern towns.**—There is a considerable difference in the labour of surveying an old and a modern town, particularly if the old is English and the modern town Colonial or American. In olden times, there was no systematic arrangement of thoroughfares; in fact, it almost seems as if, to avoid mending the holes in a bad road, the inhabitants went round them, and so made winding roads. Taking a view of the old towns as a whole, it looks as if originally there were a few isolated houses, and from every one to every other there was a direct footpath, afterwards formed into a road, the streets being short cuts from road to road.

In modern towns and cities, particularly in America, the roads are straight and the junctions rectangular, making the work of the surveyor, and also the architect, much simpler, but giving considerable trouble to the inhabitants who want to go from N.E. to S.W., or in any diagonal direction. On the whole we prefer our own picturesque and convenient arrangement, which does not necessitate barrack-like buildings on every side.

In the last chapter the *modus operandi* was described, when a comparatively small scale for the finished plan was required. The detail that can be shown on any map varies with the scale. The amount of accuracy required so that the plan may be without appreciable error, may easily be determined. Suppose every part of the plotting to be true to  $\frac{1}{100}$  of an inch, then the limit of necessary minuteness on the various



scales (provided there is no accumulating error) will be as follows:

1 mile	to	1 inch	=	about	50 feet.
6 inches	,,	1 mile	=	,,	10 ,,
3 chains	,,	1 inch	=	,,	3 ,,
100 feet	,,	1 ,,	=	,,	1 foot.
5 ,,	,,	1 mile	=	,,	10 inches.
10 ,,	,,	1 ,,	=	,,	5 ,,
$\frac{1}{8}$ inch	,,	1 foot	=	,,	1 inch.

**Double chain lines.**—A  $4\frac{1}{2}$ -inch set-off in a brick wall can be shown clearly upon plans of 20 feet to the inch or any larger scale, and this is a good general guide. When any part of a town survey is required to be plotted to a scale of 20 feet to 1 inch or larger, it is necessary to have **double chain lines** down the streets, and then rectangular offsets may be taken to the boundaries, but additional oblique offsets will be requisite to all important points where the chain line is more than 2 or 3 links away. Double chain lines are occasionally used for the main thoroughfares of a town, while only single lines are adopted for the side streets.

The ordinary field-book may be adapted for double chain lines by ruling another line outside each red line about  $\frac{3}{8}$  inch off, leaving the original central column for entering anything which occurs between the two chain lines. As illustrating the principle of double lines and close detail, the writer now gives, by special permission of Messrs. Crosby, Lockwood & Co., the notes and sketches of a survey published in Jackson's *Aid to Survey Practice*. These should be plotted carefully to a scale of 20 feet to 1 inch, when they will appear as shown in Fig. 178. In filling in the details of back premises, the tape is the only instrument used. An approximate sketch is made and the walls measured round, then diagonals are taken to those angles required for tying and checking the work.

A steel tape is the only accurate kind, but these are expensive and difficult both to use and to keep in order. Generally, the work is done with one of **Chesterman's metallic tapes**; that is, a painted linen tape with wire threads woven in. These tapes vary considerably in length, according to their dryness. The writer has known a good 66-foot tape

FIELD - RECORD  
OF  
TOWN SURVEY  
WITH THE CHAIN

FOR PLOTTING ON THE SCALE OF  $\frac{1}{120}$  OR  
10 FEET TO THE INCH.

*Chain lines are taken in links.  
Other dimensions and offsets in feet and inches*

*The coal Shoots when not marked are  
1 foot Sq; or 1 foot in diam.*

GENERAL SKETCH.

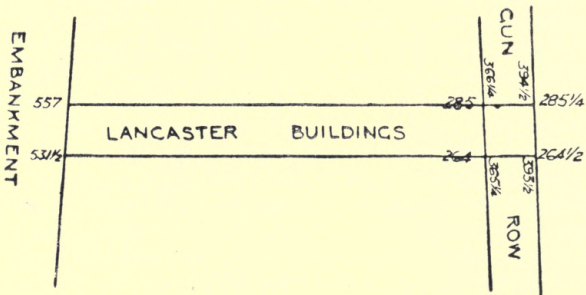

EXAMPLE OF DOUBLE CHAIN LINE 195

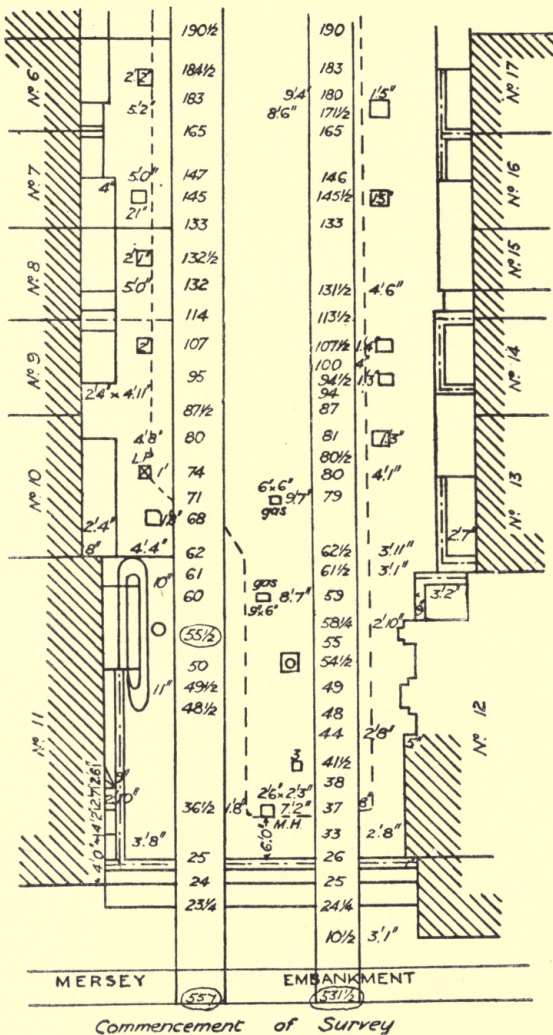

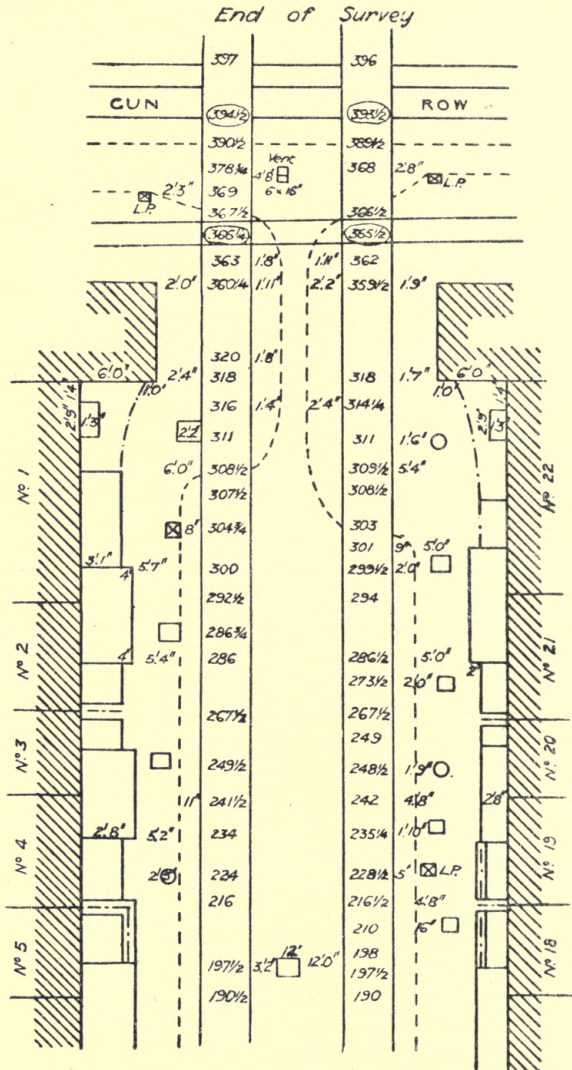

PART OF TOWN SURVEY  
WITH DOUBLE CHAIN LINES.

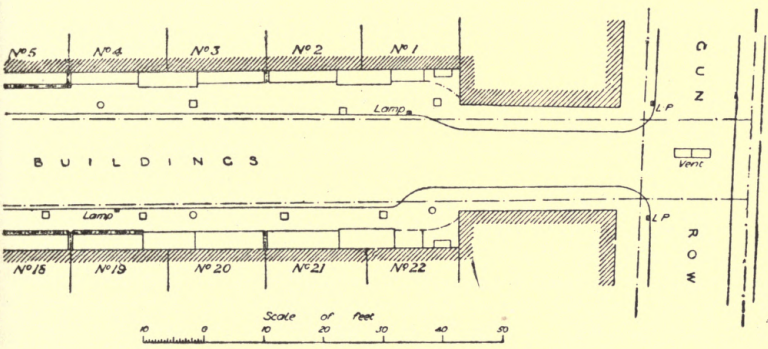
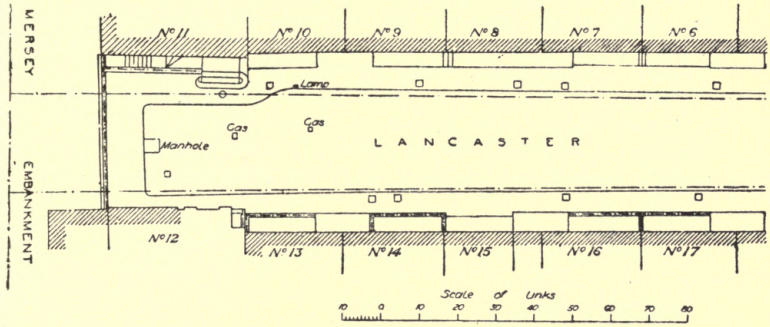

FIG. 178.—Detail plotting of street in town survey.

to vary 18 inches in length between wet and dry. The common tapes are no better than a piece of string would be.

Before leaving the premises the sketch must be carefully examined to see that all the necessary tie lines have been taken; it is very annoying to have to go over the same ground a second time solely through carelessness.

Frequently the surveyor will have to rely for assistance upon any boy or man picked up in the neighbourhood, and although it appears a simple matter, it is very difficult to get them to understand that the end of the brass ring is the part

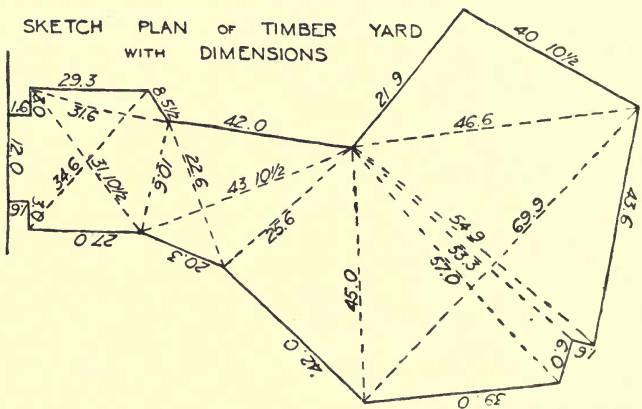

FIG. 179.—Sketch plan of timber yard with dimensions.

to be held against the wall. If not watched, they will take the ring between their thumb and finger, and hold it at right angles to the line of the tape so that the length is measured minus the length of ring. The only way to prevent it is to make them put their finger or thumb through the ring, and then it is necessary to see that when they get tired they do not twist the tape round their hand. It seems as if, because the figures are read from the other end, they think their end does not matter.

When independent measurements are taken of piers and panels on a wall, the whole length should always be taken also and used in the tie lines, because a number of small

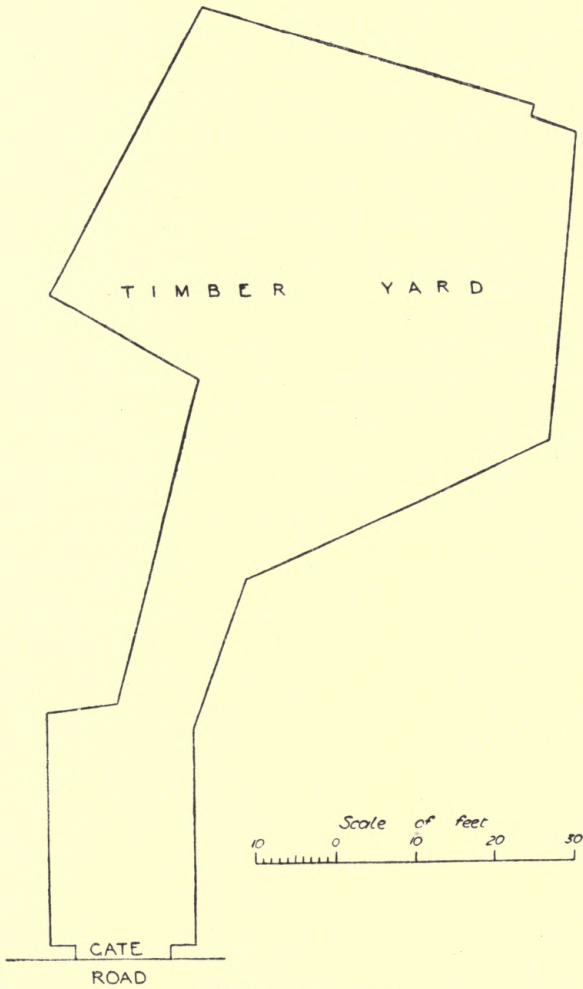

FIG. 180.—Plotting of same.

measurements will never agree exactly with the total. Parts that cannot be reached easily may be estimated with great accuracy by observing the number of bricks, either in height or length, dividing by 4 for height in feet, and deducting  $\frac{1}{4}$  for length in feet, two headers counting as one brick. Fig. 179 shows the sketch plan of back premises measured with a tape, and Fig. 180 shows the plotting of the same.

### QUESTIONS ON CHAPTER XXVII.

1. Give some idea of the degree of accuracy required in measurements according to the scale of map required.
2. A plan is drawn to a scale of  $\frac{1}{8}$  inch to 1 foot; what is the nearest measurement that can be indicated on the paper by scaling?
3. How are the details of a town survey obtained and recorded?
4. Describe the method of using a box tape for taking detail measurements. How would you check the work?
5. A house in the London suburbs has 100 courses of bricks from the ground up to the underside of cornice; what is the height in feet? Would the same number of courses give the same height in a Midland town?
6. Make a sketch of an irregular town building site and show what measurements you would take to obtain a true plan. How could you obtain the measurements before the site is cleared?



## CHAPTER XXVIII.

Principal features of railway surveying—Limits of deviation—Reference book—Railway gauges—Engineering field work—Location field work—Permanent stakes—Level pegs—Earthwork terms—Batters and slopes—Earthwork formulæ.

**Railway surveying.**—Railway surveying begins with the work of the engineer who rides, or walks, over the district with an Ordnance map and sketches upon it the route he considers best. Then trial levels are taken along the proposed line, with additional levels where it is probable that a deviation from the first suggestion will be approved. A set of Ordnance maps with the finally proposed centre line of railway is then given to the surveyor, who has to make a chain survey along the course, taking in all features within the **limits of deviation**, and the complete boundaries of those properties of which any part commences within.

The limits of deviation are usually 5 chains on each side of the centre line, but they may be 100 yards each side in the country and 10 yards in town, and only within these limits may the promoters vary the line of railway without fresh statutory powers. The survey for a railway is made by running base lines within the limits of deviation and connecting them—where a change of direction occurs—by theodolite angles, repeated to ensure accuracy.\* The chain lines are tied to these base lines by ordinary triangulation. Each parcel of land shown on the plan is numbered and the plan is accompanied by a Reference Book giving the numbered list with

\* The best practical description of railway surveying known to the writer is given in Chapters VI. to X. of H. J. Castle's *Engineering Field Notes on Parish and Railway Surveying and Levelling*. Second edition (Simpkin, Marshall & Co., London, 1847). It has, however, long been out of print.

description and the names of the owner and occupier of each parcel. The referencing is usually done by a separate staff. Main and cross sections are also prepared as explained under levelling, and the adjustment of gradients is made as shown previously in Fig. 140.

The various gauges are as follows :

#### RAILWAY GAUGES

(between inner edges of rails).

Broad gauge . . . . .	7 ft. 0 $\frac{3}{4}$ in. = 7.06 ft.
Indian „ . . . . .	5 „ 6 „ = 5.5 „
Irish „ . . . . .	5 „ 3 „ = 5.25 „
Standard narrow gauge . . . . .	4 „ 8 $\frac{1}{2}$ „ = 4.71 „
Australian „ . . . . .	3 „ 6 „ = 3.5 „
Metric „ . . . . .	3 „ 3 $\frac{3}{8}$ „ = 3.281 „
Hill and tramway „ . . . . .	{ 3 „ 6 „ = 3.5 } „ to to 1 „ 6 „ = 1.5 } „

**Engineering field work.**—Engineering field work in its full sense comprises all branches of land surveying and levelling, together with the setting out of intended works, but as usually understood it is limited to the “setting out” or “location” of proposed works by means of centre lines, side widths, and levels—whether for roads, railways, canals, or any incidental structures. Land surveying, as so far described, consists of ascertaining all particulars of existing features of the ground, “setting out” assumes all features known and places upon those features certain marks for future use.

The centre line of the route is the part which first receives attention; it is drawn out carefully upon an accurate (or supposed accurate) plan and has to be transferred to the ground. A diary should always be kept for recording the date of setting out any work, particularly detached works, such as bridges, culverts, etc., as in the event of delays the date is always disputed. The book varies in different cases, but the following shows a typical form.

**Location field-book.**—Ranging straight lines may be done by the eye with a few station poles when for short distances only, but generally speaking a 6-inch transit theodolite reading

to 20 or 30 seconds is required. The ranging of curves will be taken later on, and in considerable detail, as it is the most important and difficult part of the engineer's work. In English practice, Gunter's chains have been generally used and the distances marked in miles and chains, or miles, furlongs and chains; but in the most recent work 100 feet chains have been used.

The permanent stakes to mark the centre line are 3 inches square and 3 feet long, painted and numbered, the distance apart being say 5 chains in open country, 1 or 2 chains through towns, and  $\frac{1}{2}$  chain on curves. At every 10th chain *two* pegs

Distance from beginning of section	Formation level	Levels of bench marks, stakes or other marks	Depths of cutting and heights of embankment	Lateral slope from centre line outwards		Side widths on each side	Remarks. Gradients, Curves, Spans, Headways, Foundations, Springing, &c &c Descriptions of bench marks.
				R	L		

FIG. 181.—Working section book.

are placed, and at every tangent point where a curve starts or terminates *three* pegs. In American practice where the 100-foot chain is used, the permanent stakes "are generally placed at distances of 100 feet apart through the whole line from the commencement, in towns or crowded localities they are interpolated by pegs at every 50 feet apart, and on sharp curves at 25 feet apart." The difficulty of setting out is largely dependent upon the nature of the country; when tolerably flat it is simple enough, but in hilly countries where cutting and embankment, tunnel and viaduct, rapidly succeed each other, the labour is very heavy.

**Level pegs** are generally round when separate pegs are used, but sometimes the level is cut on the permanent stakes. Level

pegs are required at every alteration of gradient, at all junctions and crossings, and at all sites of bridges, culverts, stations, etc. For embankments, poles are set up clear of the bank and cross pieces nailed upon them to show the intended final level. For tunnelling, iron staples and spikes are used driven into the timbers of the headings. In setting out the foundations of bridges and other structures, the marks have to be kept quite clear of the work, so that they may be referred to at any time during its progress. *E.g.* a square block would be marked as

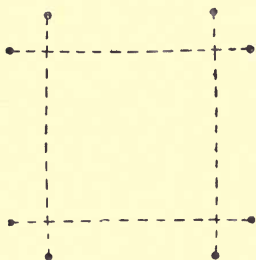

FIG. 182.—Pegs for setting out a square block.

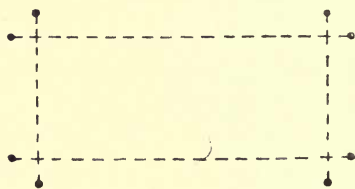

FIG. 183.—Pegs for setting out a trench.

Fig. 182, and a trench as Fig. 183. In each case the measurement of the two diagonals from the corners checks the accuracy of the setting out.

**Earthwork terms.**—**Formation breadth** = Actual width of roadway.

**Side-width** = Half formation breadth + Extra portion due to slope of ground and intended side slope.

**Land-breadth** = side-width + additional land for hedge, ditch, etc.

**Batters and slopes.**—Batter of 2 inches per foot = 2 inches horizontal in 1 foot vertical.

Batter of 1 in 10 = 1 horizontal in 10 vertical.

Slope of  $1\frac{1}{2}$  to 1 =  $1\frac{1}{2}$  horizontal to 1 vertical.

Slope of 1 in 20 = 1 vertical to 20 horizontal.

$$\text{Rise of } A^\circ = \text{slope of 1 in } \frac{\cos A^\circ}{\sin A^\circ} = 1 \text{ in } \frac{1}{\tan A^\circ}.$$

After setting out and marking the centre line of the railway, a cross section of the ground surface is taken at each permanent stake and plotted in the office to a natural scale, *i.e.* horizontal and vertical scales equal. The central heights or depths of the formation level are marked on them and the

CALCULATION OF SIDE WIDTHS  
IN CUTTINGS OR EMBANKMENT

- h* = central height or depth of earthwork at any given section or half-section.
- b* = the formation breadth.
- f* to 1 = the intended side-slope.
- g* to 1 = the natural lateral inclination of the ground.
- AB* = the side-width

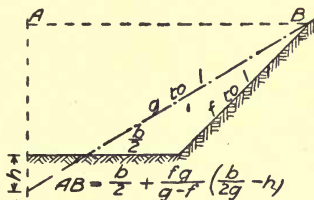
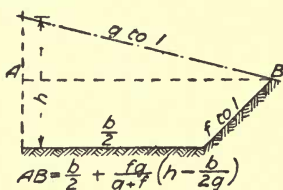
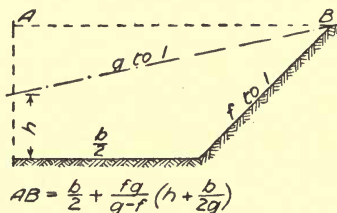
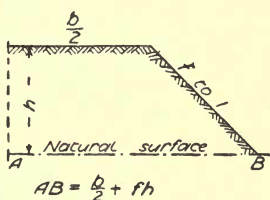

FIG. 184.—Formulae for earthwork calculations (side-widths).

formation level shown by a horizontal line cut off on each side at formation breadth, which is 30 feet for two lines of way, occupied with 27 feet by 10 inches of ballast and two 18-inch ditches, or 28 feet of ballast with 12-inch drain pipes. A cardboard templet, having on it the half formation breadth and proper side slope to suit the soil, enables the slope to be ruled in, from which the side width may be scaled off and the con-

tents estimated. If it be desired to calculate the side width the formulæ shown on the diagrams in Fig. 184 must be employed. The same diagrams inverted or turned from left to right will give all the other cases that can arise. For

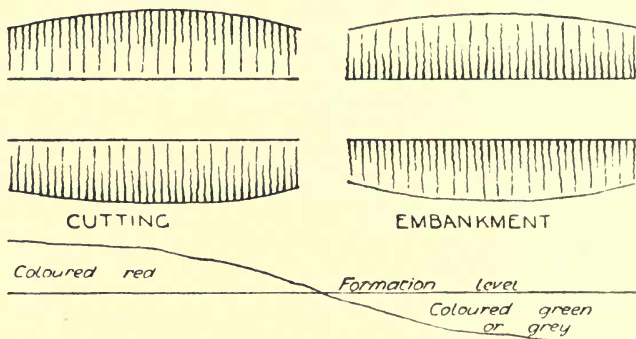

FIG. 185.—Indication of cuttings and embankments on completed plans and sections.

the land-breadths 8 feet or 10 feet “cess” is usually allowed between edge of slope and fence; this is marked on the plan and set out on the ground when required. On the completed plans and sections, cuttings and embankments are shown as in Fig. 185.

### QUESTIONS ON CHAPTER XXVIII.

1. What do you understand by the “limit of deviation”?
2. The survey for a railway being very long and narrow but not straight, how are the various portions connected?
3. Name and give the dimensions of the most common railway gauges.
4. What does “engineering field work” consist of?
5. Show by sketches the difference in the use of the terms “batter” and “slope.”
6. How far apart are the “permanent stakes” usually placed in setting out a railway, and under what conditions would they be set closer?

## CHAPTER XXIX.

Railway curves—Nomenclature of curves—Minimum radius—Curve “elements” and formulae—Simple and compound curves—Reverse curves.

**Railway curves.**—It is not possible to construct a road or railway of any considerable length in a straight line on account of obstructions and the necessity of slight deviations to avoid expensive work such as tunnels, bridges, and viaducts. The change of direction, however slight, has to be made by the intervention of a curve of as large a radius as possible, and it

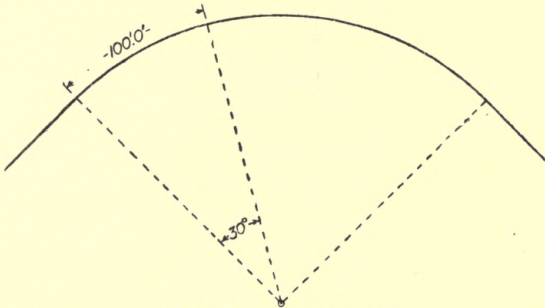

FIG. 186.—“30 degree curve.”

is therefore desirable to consider the question of curves, first theoretically and afterwards practically.

Formerly the curves were designated by their radius in chains of 66 ft. up to 80 chains and beyond that in miles, but on new railways they are now generally expressed in hundreds of feet. In the American system they are named by the number of degrees in the centre angle subtending 100 ft. on the curve, so that the greater the radius the smaller the angle. Fig. 186

shows the method, where the curve would be called a "30 degree curve." The radius in feet is given by the constant 5730 divided by the number of degrees.

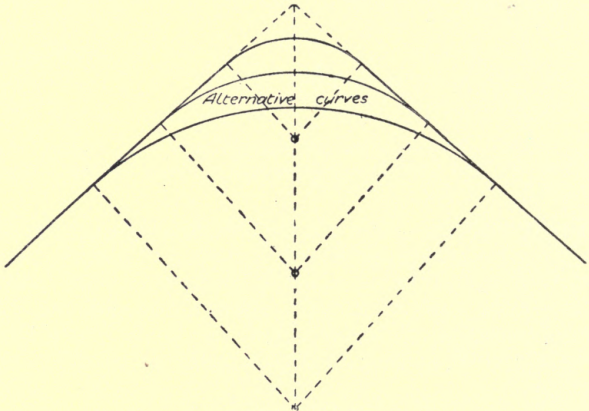

FIG. 187.—Simple curve.

**Nomenclature.**—A simple curve is one consisting of a single arc of any given radius, as in Fig. 187.

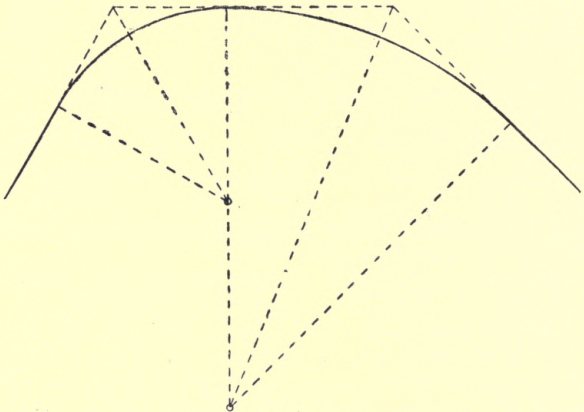

FIG. 188.—Compound curve.



A **compound curve** is one that is composed of two or more arcs of different radii, as in Fig. 188.

**Inverted, reverse or S curves** are alternatively concave and convex, as shown in Fig. 189.

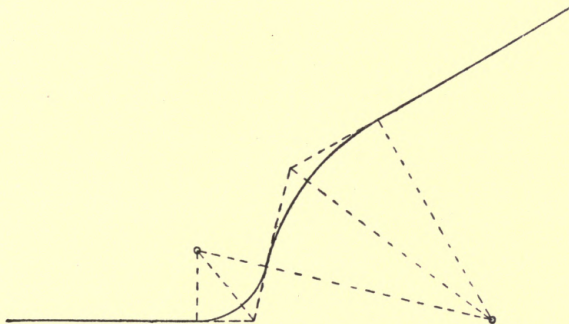

FIG. 189.—Inverted, reverse, or S curves.

For main lines on first-class railways, 4 ft. 8½ in. gauge, the minimum radius of curve is 1 mile. The minimum radius for branch lines is 25 chains and for sidings 5 chains.

**Curve elements.**—Fig. 190 shows the various **curve elements**, or lines and angles occurring in connection with circular curves, together with their names, and the following equations give the mathematical value of each.

$$\text{Chord of } \frac{1}{2} \text{ arc} = \sqrt{\left(\frac{1}{2} \text{ span}\right)^2 + \text{rise}^2} = \sqrt{\left(\frac{1}{2}s\right)^2 + v^2}.$$

$$\text{Radius (R)} = \frac{1}{2} \left[ \frac{\left(\frac{1}{2} \text{ span}\right)^2}{\text{rise}} + \text{rise} \right] = \frac{1}{2} \left( \frac{\left(\frac{1}{2}s\right)^2}{v} + v \right) = \frac{\frac{1}{4}s^2 + v^2}{2v},$$

$$\text{or } \frac{\text{span}}{2 \sin \gamma} = \frac{s}{2 \sin \gamma}.$$

$$\cos \beta = 1 - \frac{(\text{Chord of whole arc})^2}{2 \times \text{radius}^2} = 1 - \frac{s^2}{2R^2},$$

whence  $\beta$  is obtained from table and  $a = 180 - \beta$ .

$$\sin \gamma = \sin \frac{\beta}{2} = \frac{\left(\frac{1}{2} \text{ span}\right)^2}{\text{Curve tangent (radius - rise)}} = \frac{\frac{1}{4}s^2}{T(R - v)},$$

P.S.

O

$$\text{or } \sin \gamma = \frac{2 \text{ rise} \times (\frac{1}{2} \text{ span})^2}{\text{Curve tangent} \{(\frac{1}{2} \text{ span})^2 - \text{rise}^2\}} = \frac{\frac{1}{2} v s^2}{T (\frac{1}{4} s^2 - v^2)}$$

$$\text{or } \sin \gamma = \frac{2 \text{ rise} \times \frac{1}{2} \text{ span}}{\text{rise}^2 + (\frac{1}{2} \text{ span})^2} = \frac{vs}{v^2 + \frac{1}{4} s^2}$$

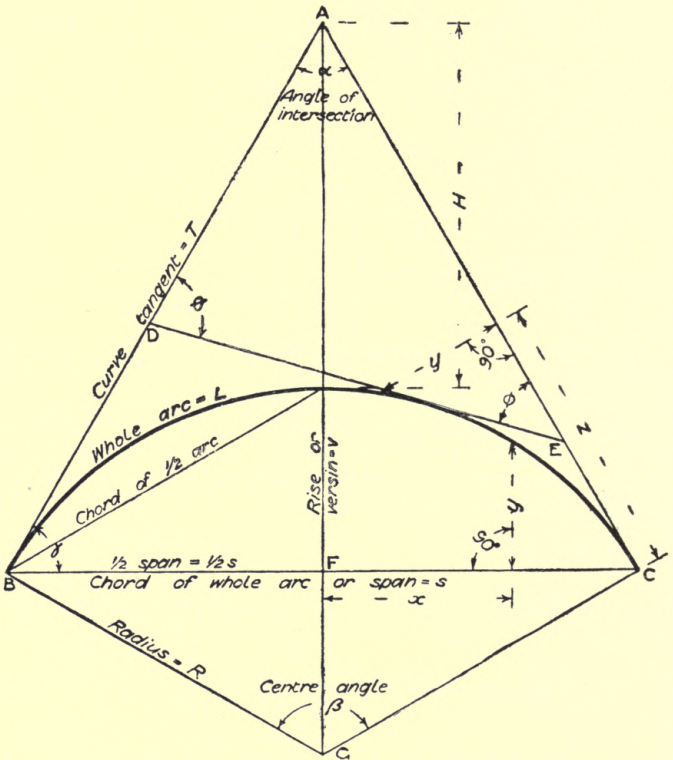

FIG. 190.—Diagram showing curve elements.

Angle between tangent and any chord =  $\frac{1}{2}$  centre angle of chord.

$$\text{Curve tangent (T)} = R \cot \frac{\alpha}{2} = R \tan \frac{\beta}{2} = R \tan \left( 90 - \frac{\alpha}{2} \right)$$

$$= \sqrt{\left( \frac{2 \text{ rise} \times \frac{1}{2} \text{ span}^2}{\frac{1}{2} \text{ span}^2 - \text{rise}^2} \right)^2 + \frac{1}{2} \text{ span}^2}$$

$$= \sqrt{\left( \frac{\frac{1}{2} v s^2}{\frac{1}{4} s^2 - v^2} \right)^2 + \frac{1}{4} s^2},$$

$$\text{Span (s)} = 2R \sin \left( 90 - \frac{\alpha}{2} \right).$$

$$H = \sqrt{(\text{curve tan})^2 + \text{rad.}^2} - \text{radius} = \sqrt{T^2 + R^2} - R,$$

$$\text{or } R(\sec \gamma - 1) = R \left( \operatorname{cosec} \frac{\alpha}{2} - 1 \right).$$

$$\text{Rise (v)} = \text{rad.} - \sqrt{\left( \text{rad.}^2 - \frac{\text{chord}^2}{4} \right)} = R - \frac{\text{Curve tan} - \frac{1}{2} \text{ span}}{\text{Curve tan}}$$

$$= R \frac{(T - \frac{1}{2}s)}{T} = \frac{1}{2}s \tan \frac{\beta}{4} = 2R \sin^2 \frac{\beta}{4},$$

$$\text{AF} = H + v \text{ or } \frac{(\frac{1}{2}s)^2}{R - v} \text{ or } R \sqrt{\cot^2 \frac{\alpha}{2} + 1} - R + 2R \sin^2 \frac{180 - \alpha}{4},$$

$$\text{FG} = R - v = R - 2R \sin^2 \frac{180 - \alpha}{4},$$

$$y \text{ for } x = \sqrt{\text{rad.}^2 - x^2} - (\text{rad.} - \text{rise}) = \sqrt{R^2 - x^2} - (R - v),$$

$$y \text{ for } z = \text{rad.} - \sqrt{\text{rad.}^2 - z^2} = R - \sqrt{R^2 - z^2}.$$

$$\text{Length of the whole curve (L)} = \frac{4\pi}{360} R \left( 90 - \frac{\alpha}{2} \right)$$

$$= .0349066 R \left( 90 - \frac{\alpha}{2} \text{ in degrees and decimals} \right).$$

$$\text{Curve to touch 3 given lines BD, DE, EC; } R = \frac{\text{DE}}{\tan \frac{\theta}{2} + \tan \frac{\phi}{2}}.$$

Curve to touch 2 given lines BA, AC, and one of them in a given point B. Make AC = AB = T, then  $R = \frac{T \times s}{2\sqrt{T^2 - \frac{1}{4}s^2}}$ .

To find  $\alpha$  when T and s are given,

$$\sin \frac{\alpha}{2} = \frac{s}{2T}, \text{ whence } \frac{\alpha}{2}, \text{ and } 2\left(\frac{\alpha}{2}\right) = \alpha.$$

The above will be found to give all the information needed for calculating from certain particulars the remaining portions so far as regards simple circular arcs. A few questions and worked examples upon these formulæ will render them clearer.

*Ex. 1. With an angle of intersection of 75 degrees, a radius of 100 feet, what will be the length of the curve tangents, length of whole curve, distance from point of intersection to middle point of curve, and the chord, or span of whole curve?*

$$\begin{aligned} T &= R \cot \frac{\alpha}{2} = 100 \times \cot \frac{75}{2} \\ &= 100 \times 1.3034 = 130.34 \text{ feet. } \mathbf{Ans.} \end{aligned}$$

$$\begin{aligned} L &= 0.039066 R \left(90 - \frac{\alpha}{2}\right) \\ &= 0.0349066 \times 100 \times \left(90 - \frac{75}{2}\right) \\ &= 183.26 \text{ feet. } \mathbf{Ans.} \end{aligned}$$

$$\begin{aligned} H &= R \left(\operatorname{cosec} \frac{\alpha}{2} - 1\right) \\ &= 100 \left(\operatorname{cosec} \frac{75}{2} - 1\right) = 100(1.6427 - 1) \\ &= 64.27 \text{ feet. } \mathbf{Ans.} \end{aligned}$$

$$\begin{aligned} s &= 2R \sin \left(90 - \frac{\alpha}{2}\right) \\ &= 2 \times 100 \times \sin 52^\circ 30' \\ &= 2 \times 100 \times 0.7933 = 158.66 \text{ feet. } \mathbf{Ans.} \end{aligned}$$

Ex. 2. With the angles  $\alpha = 75$ ,  $\theta = 45$ ,  $\phi = 60$ , and cross tangent to curve = 99.15 feet, what will be the required radius of curve?

$$R = \frac{\text{Cross tangent}}{\tan \frac{\theta}{2} + \tan \frac{\phi}{2}} = \frac{99.15}{\tan \frac{45}{2} + \tan \frac{60}{2}}$$

$$= \frac{99.15}{0.9915} = 100 \text{ feet. Ans.}$$

Ex. 3. With an angle of intersection of 75 degrees, curve tangents of 130.32 ft. and whole chord of 158.66 ft., what will be the radius of curve?

$$R = \frac{T}{\cot \frac{\alpha}{2}} = \frac{130.32}{\cot \frac{75}{2}} = \frac{130.32}{1.3032} = 100 \text{ ft. Ans.}$$

$$\text{or } R = \frac{S}{2 \sin \left(90 - \frac{\alpha}{2}\right)} = \frac{158.66}{1.5866} = 100 \text{ ft. Ans.}$$

Ex. 4. Given  $R = 100$  ft., what "degree" curve will it be called?

$$\text{Circumference of whole circle} = \pi d = 3.1416 \times 100 \times 2$$

$$= 628.32 \text{ ft.}$$

$$\therefore \text{angle subtended by 100 ft.} = \frac{100}{628.32} \times 360$$

$$= 57.29578 \text{ degrees. Ans.}$$

Ex. 5. With a span of 50 ft. and versine of 12 ins., what will be the radius of the curve?

See Fig. 191.

$$CD : DB :: DB : DE$$

$$DE = \frac{(DB)^2}{CD},$$

$$R = \frac{DE + DC}{2}$$

$$= \frac{\frac{25^2}{1} + 1}{2} = \frac{625 + 1}{2} = 313 \text{ ft.}$$

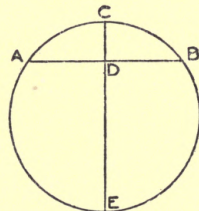

FIG. 191.—Finding radius of curve from chord and versine.

Ans. : 313 ft.

**Compound Curves.**—Attention may now be directed to compound curves, or those made up of two separate curves of different radii.

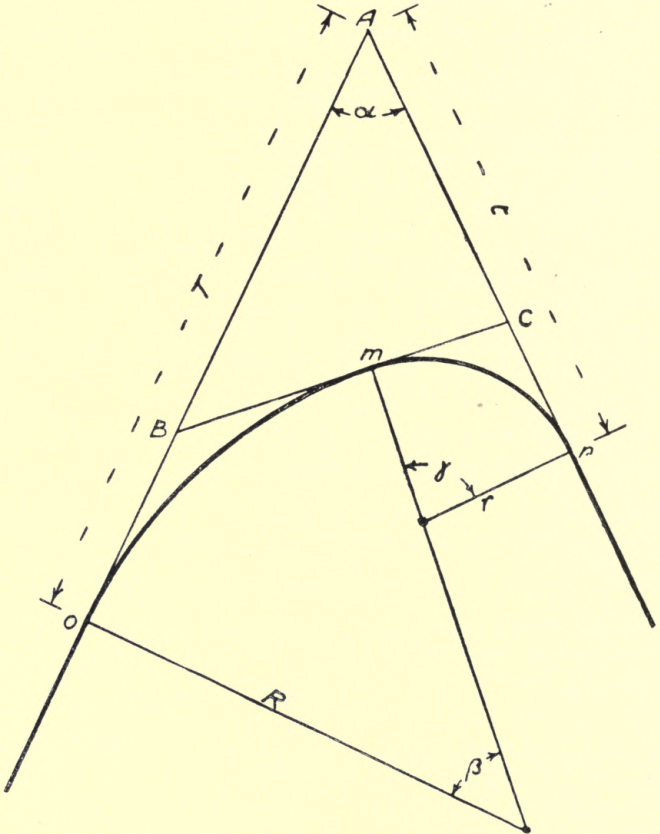

FIG. 192.—Problem in compound curves.

Fig. 192. shows the general type of problem required to be elucidated, and the various formulæ involved are as follows: Given  $\alpha$ ,  $t$ ,  $r$ , and  $R$ , to find  $T$ .

(Note.  $x$  = imaginary angle, used as  $a$  means to an end.)

$$\sin x = \frac{R + \sin a(r \cot a - t)}{R - r},$$

$$Cn = r \tan \frac{x + 90 - a}{2},$$

$$Cm = Cn, AC = t - Cn,$$

$$AB = AC \frac{\sin(x + 90 - a)}{\sin(90 - x)},$$

$$BC = \sqrt{AB^2 + AC^2 - (2 \times AB \times AC \times \cos a)},$$

$$ABC = 90 - x, ACB = x + 90 - a,$$

$$Bm = Bo = BC - Cm,$$

$$T = r \cot a \sec a + \cos a(t - r \cot a) + \cos x(R - r) \\ = AB + Bo.$$

Given  $a$ ,  $T$ ,  $R$ , and  $om$ , to find  $r$ .

$$\gamma = 180 - a - \beta,$$

$$r = \frac{R\{\cos(180 - a) - \cos \gamma\} + T \sin(180 - a)}{1 - \cos \gamma}.$$

Given  $T$ ,  $t$ ,  $a$  and  $m$ , to find  $R$  and  $r$ .

$$\cos Aom = \frac{T^2 + om^2 - Am^2}{2 \cdot T \cdot om} \text{ whence angle } Aom,$$

$$\text{then } R = \frac{om}{2} \times \text{cosec } Aom,$$

$$\cos Anm = \frac{t^2 + mn^2 - Am^2}{2 \cdot t \cdot mn} \text{ whence angle } Anm,$$

$$\text{then } r = \frac{mn}{2} \times \text{cosec } Anm.$$

For example :

Let  $a = 52^\circ 1' 50''$ ,  $t = 142.5$ ,  $r = 50$ ,  $R = 150$ ,  
find the remaining elements.

$$\sin x = \frac{150 + 0.7883(50 \times 0.7804 - 142.5)}{150 - 50} = 0.6841,$$

$$x = 43^\circ.10',$$

$$Cn = 50 \times \tan 40^\circ 34' 5'' = 50 = 0.8561 = 42.8,$$

$$AC = 142.5 - 42.8 = 99.7,$$

$$AB = \frac{99.7 \times \sin 81^\circ 8' 10''}{\sin 46^\circ 50'} = \frac{99.7 \times 0.988053}{0.7294} = 134.9,$$

$$BC = \sqrt{134.9^2 + 99.7^2 - 2 \times 134.9 \times 99.7 \times 0.61522} = 107.7,$$

$$ABC = 90^\circ - 43^\circ 10' = 46^\circ 50',$$

$$ACB = 43^\circ 10' + 90^\circ - 52^\circ 1' 50'' = 81^\circ 8' 10'',$$

$$T = 50 \times 0.7804 \times 1.62542 + 0.61522(142.5 - 50 \times 0.7804) \\ + 0.72937(150 - 50)$$

$$= 63.28 + 63.67 + 72.93 = 199.88,$$

$$Bo = 199.88 - 134.9 = 64.98.$$

It is sometimes necessary to make a detour on a single

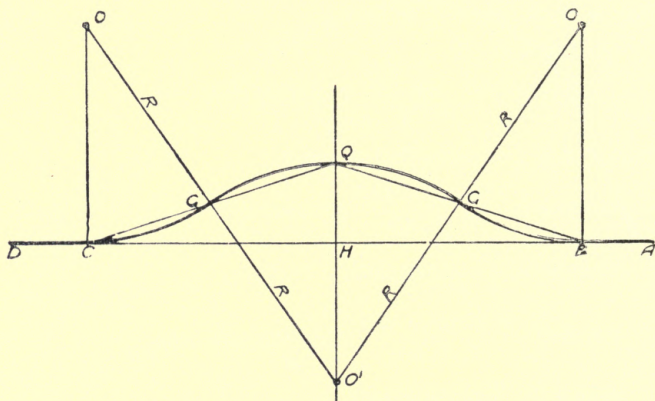

FIG. 193.—Detour on a single track with four curves of the same radius.

track, as in Fig. 193, where all four curves have the same radius. Then given  $BC$  and  $QH$ ,

$$R = BO = \frac{HC^2 + QH^2}{4QH},$$

$$BG = GQ = QG' = G'C = \sqrt{BO \times QH}.$$



Given QH and BO,

$$BH = HC = \sqrt{QH(4BO - QH)}.$$

Fig. 194 shows reverse curves of equal radius to join two pieces of straight making any angle with each other. The formulæ will be as follows :

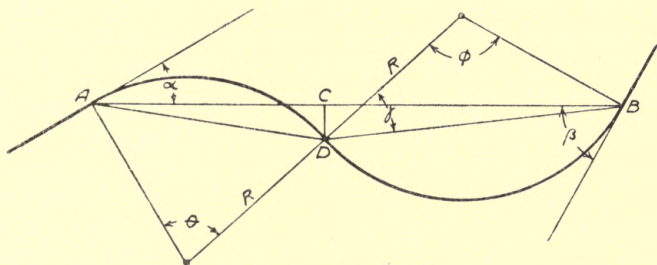

FIG. 194.—Reverse curves to join two pieces of straight.

Given A, B,  $\alpha$  and  $\beta$ , to find R and the junction of the curves.

$$\sin \gamma = \frac{\cos \alpha + \cos \beta}{2},$$

$$\theta = 180 - 90 + \alpha - \gamma = 90 + \alpha - \gamma,$$

$$\phi = 180 - 90 + \beta - \gamma = 90 + \beta - \gamma,$$

$$R = \frac{AB \sin \gamma}{\sin \theta + \sin \phi}$$

$$= \frac{AB}{\sin \alpha + \sin \beta + 2 \sin (90 - \gamma)},$$

$$AD = R\sqrt{2 - 2 \cos \theta},$$

$$CAD = \frac{\theta - 2\alpha}{2},$$

$$CD = AD \cdot \sin CAD = R\sqrt{2 - 2 \cos \theta} \times \sin \frac{\theta - 2\alpha}{2},$$

$$AC = R\sqrt{2 - 2 \cos \theta} \times \cos \frac{\theta - 2\alpha}{2},$$

$$BD = R\sqrt{2 - 2 \cos \phi},$$

$$CB = AB - AC = R\sqrt{2 - 2 \cos \phi} \times \cos \frac{2\beta - \phi}{2}.$$

Generally it is stipulated that reverse curves shall be separated by a length of straight to prevent a sudden change of cant in passing over them, and in colonial work the directions of the various straight portions are given by their bearings east of north, clockwise. Fig. 195 gives an example, which is worked out as follows :

$$\text{Angle } ABC = 55^\circ + (180^\circ - 129^\circ 16') = 105^\circ 44' = \alpha.$$

$$\text{Angle } BCD = (180^\circ - 129^\circ 16') + 77^\circ 28' = 128^\circ 12' = \alpha_1.$$

$$\text{Centre angle opposite } ABC = 180^\circ - 105^\circ 44' = 74^\circ 16' = \beta.$$

$$\text{Centre angle opposite } BCD = 180^\circ - 128^\circ 12' = 51^\circ 48' = \beta_1.$$

Let  $T$  and  $T_1$  = length of curve tangents, then

$$T + T_1 = 11.70 - 3.00 = 8.70.$$

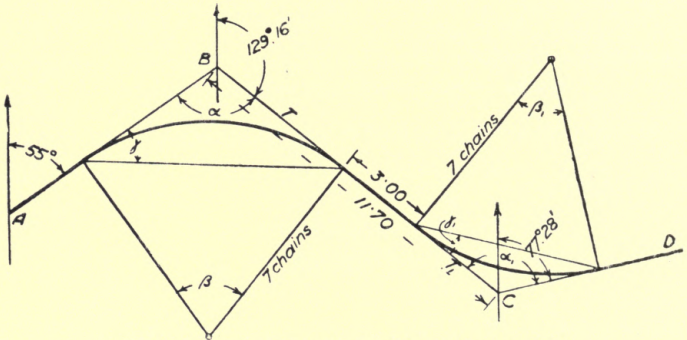

FIG. 195.—Reverse curves separated by a piece of straight.

Let  $x$  = required radius.

$$\gamma = 90 - \frac{\alpha}{2} = 37^\circ 8'.$$

$$\gamma_1 = 90 - \frac{\alpha_1}{2} = 25^\circ 54'.$$

$$T = x \tan \gamma = x \tan 37^\circ 8' = x \times 0.75721$$

$$T_1 = x \tan \gamma_1 = x \tan 25^\circ 54' = x \times 0.48557$$

$$\underline{1.24278}$$

$$\therefore 1.24278 x = T + T_1,$$

but  $T + T_1 = 8.70 \therefore x = \frac{8.70}{1.24278} = 7$  chains radius.

QUESTIONS ON CHAPTER XXIX.

1. How are railway curves designated to indicate their curvature?
2. Show by sketches the difference between simple, compound, and reverse curves.
3. The angle of deflection of a railway curve is  $14^{\circ} 28' 30''$  and the chord 1000 feet, what is the radius? (**Ans.:** 2000 ft.)
4. The angle of intersection of two centre lines is  $57^{\circ} 34'$  and the radius 1320 feet. What is the length of the curve tangents? (**Ans.:** 2402.73 ft.)
5. Why are reverse curves made with a short piece of straight between them?
6. Explain what is meant by centrifugal force, and state what is its effect upon a train going round a curve.

## CHAPTER XXX.

Difference in length of inner and outer rails—Centrifugal force and  
 superelevation of outer rails—Widening of gauge on curves—  
 Transition curves.

**Inner and outer rails.**—In going round a curve the outer rail will be longer than the inner rail, but the maximum difference allowed in the radial line of the joints is 3 inches. This is effected by having a certain number of rails 3 inches shorter than the others, so that when the projection reaches 3 inches a short rail is laid next.

By calculation the difference in length between the inner and outer rail is found thus :

- R = radius of curve to centre line of rails.
- G = width of gauge inside to inside of rails.
- w = width of rail top.
- L = length of outer rail.
- l = length of inner rail.

(All in feet).

$$l = L \frac{R - \frac{1}{2}G - W}{R + \frac{1}{2}G + W}.$$

Or, the difference in length in feet per chain of 66 ft. on the centre line  $= \frac{G}{R}$ , or approx.  $\frac{5}{R}$ ,

*e.g.* 20-chain radius,  $\frac{5}{20} = 0.25$  ft., or 3 miles radius,  $\frac{5}{240} = 0.021$  ft.

In bending rails by a "Jim Crow," if L be length of rail in feet, and R radius of curve in feet, the versine at centre will be  $\frac{1.56 L^2}{R}$ .

**Effect of centrifugal force.**—When rails are laid on a curve it is necessary to raise the level of the outer above the inner rail, or **cant the track** to counteract the effect of centrifugal force. Centrifugal force is the tendency of the vehicle to mount the rails at any point and continue in a straight line instead of following the curve. If the rails were laid on the same level, the pressure of the flanges against the outer rails, or in other words, the centrifugal force, would be measured by the formula

$$F = \frac{Wv^2}{gr},$$

where  $F$  = centrifugal force in tons,  $W$  = weight of vehicle in

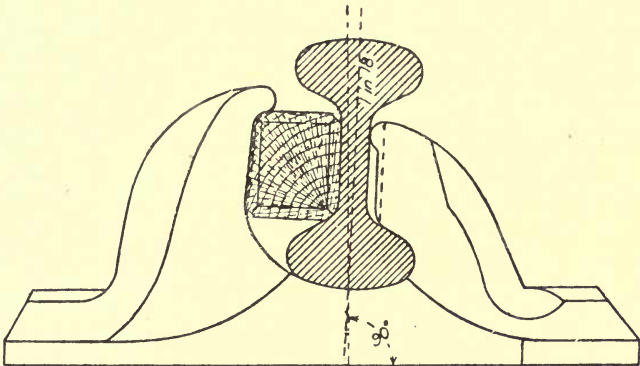

FIG. 196.—Double-headed rail in a cast-iron chair.

tons,  $v$  = velocity in ft. per sec.,  $g$  = force of gravity = 32.2,  $r$  = radius of centre line of curve in ft.

Taking the velocity in miles per hour ( $V$ ) and the radius of curve in ft. ( $r$ ) the super-elevation of outer rail in inches (or difference of level of the two rails for standard 4 ft.  $8\frac{1}{2}$  in. gauge) will be  $3.8 \frac{V^2}{r}$ , therefore the needful super-elevation

varies as the square of the velocity and inversely as the radius.

The "platelayers' rule" for super-elevation is to make it equal to the versine of the curve of outer rail for a chord one chain (66 ft.) in length, with a maximum of 5 inches. More

accurately, the length of chord upon which the versine is measured should be  $= \frac{v \text{ ft. per sec.}}{2} \times \sqrt{\text{gauge in feet}}$ . In America, the common allowance for super-elevation is  $\frac{1}{2}$  inch

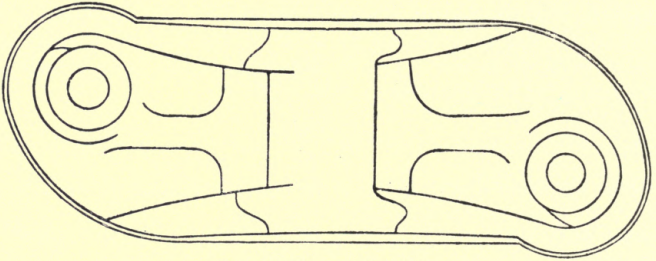

FIG. 197.—Plan of the chair.

per degree of curve. A check rail is sometimes fixed on the inside of the inner rail at a curve.

The rails themselves are usually fixed in the chairs with a cant of 1 in 18 towards the centre of the track. Fig. 196 shows a double-headed rail in a cast-iron chair; Fig. 197 a

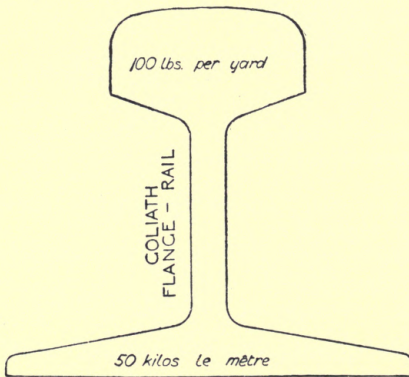

FIG. 198.—Goliath flange rail.

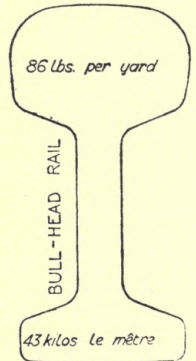

FIG. 199.—Bull-headed rail.

plan of the chair; Fig. 198 a Goliath flange rail weighing 100 lb. per yard; and Fig. 199 an 86-lb. bull-headed rail.

**Widening of gauge.**—On curved tracks it is not only necessary to give super-elevation to the outer rail to overcome the effect of centrifugal force at the maximum velocity, but, to allow for the rigid wheel base in the type of rolling stock in general use, a widening of the gauge is required.

$D$  = degree of curve, standard gauge.

$p$  = flange play in inches.

$I$  = rigid wheel base in ft.

$$D = \frac{3825p}{I^2}.$$

The widening of gauge should begin with a 6 degree curve and increase  $\frac{1}{2}$  inch per degree up to 1 inch. Beyond 16 degrees guard rails should also be used. The standing clearance to flange is  $\frac{5}{8}$  inch.

For the least possible radius, let

$W$  = wheel base of rolling stock in feet.

$G$  = gauge of railway in feet.

$R$  = minimum radius of curve in feet.

$k = 5$  for keyed wheel,  $2\frac{1}{2}$  for loose wheels.

$$R = kWG.$$

For an approximate rule to estimate existing curves it may be noted that if a 2-foot chord has rise of  $n$  inches, then radius of curve =  $\left(\frac{6}{n} + \frac{n}{24}\right)$ .

On the London and North-Western Railway it was decided in 1897 that all curves under 1 mile radius should be compounded, leaving the straight with  $\frac{1}{2}$  chain at 1 mile radius,  $\frac{1}{2}$  chain at  $\frac{3}{4}$  mile radius,  $\frac{1}{2}$  chain at  $\frac{1}{2}$  mile radius, and branch lines should have no curve less than 28 chains radius.

Fig. 200 shows a diagram for a simple case of compounding, the formulæ for which are as follows :

Given  $T$ ,  $R$ ,  $r$  and  $\alpha$ , to find the lengths of the curves.

$$EAD = ADE = \frac{180 - \alpha}{2}.$$

$$AD = T\sqrt{2 - 2 \cos \alpha}.$$

$$\text{DAG} = \text{ADF} = \frac{\alpha}{2}$$

$$\text{AF} = \sqrt{\text{AD}^2 + \text{R}^2 - 2 \cdot \text{AD} \cdot \text{R} \cos \frac{\alpha}{2}}$$

$$\sin \text{DAF} = \frac{\text{R} \sin \frac{\alpha}{2}}{\text{AF}}, \text{ whence angle DAF.}$$

$$\text{AFD} = 180 - \text{DAF} - \text{ADF.}$$

$$\text{GAF} = \text{DAF} - \text{DAG.}$$

$$\text{FG} = \sqrt{\text{AF}^2 + \text{R}^2 - 2 \cdot \text{AF} \cdot \text{R} \cos \text{GAF.}}$$

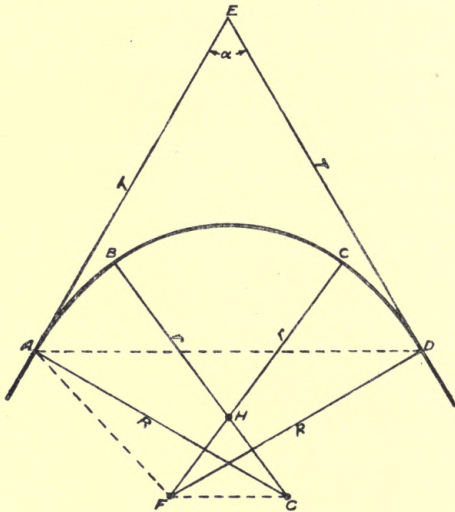

FIG. 200.—Compounding curves.

$$\cos \text{FHG} = \frac{2(\text{R} - r)^2 - \text{FG}^2}{2(\text{R} - r)^2}, \text{ whence angle FHG} = \text{BHC.}$$

$$\text{Length of BC} = 2\pi\text{R} \times \frac{\text{BHC}}{360}.$$

$$\sin \text{AGF} = \frac{\sin \text{GAF} \times \text{AF}}{\text{FG}}, \text{ whence angle AGF.}$$



$$\cos \text{HGF} = \frac{\text{FG}}{2(\text{R} - r)}, \text{ whence HGF.}$$

$$\text{BGA} = \text{HGF} - \text{AGF.}$$

$$\text{Length of AB or CD} = 2\pi\text{R} \times \frac{\text{BGA}}{360}.$$

**Transition curves.**—A transition curve is based upon the principle of compound curves, but when a pure circular curve is entered directly from the straight, centrifugal force acts very suddenly on each vehicle; this sudden action of the centrifugal force produces a swing, similar to the swing of a pendulum bob when drawn aside and released. As a rule, the outer rail on the straight leading to the curve is gradually superelevated, so that the proper amount of cant is attained at the entrance to the curve, but this cannot lessen the extent of the swing, although it lessens the sense of discomfort to the passengers. The over-swing or pendulum effect is augmented by reversal of curvature, and consequently it is at such points discomfort is most felt. The true purpose of a transition curve is, therefore, to enable the centrifugal force to be applied gradually.

An efficient transition curve should allow of a rate of gain or loss of radial acceleration for the fastest trains just equal to the maximum amount that will pass unnoticed. The radial acceleration of a car moving  $v$  feet per second in a curve of  $r$  feet radius equals  $v^3/r$ ; so that, neglecting the easing effect due to the length of a coach, the rate of gain of acceleration when a car enters a curve of  $r$  feet radius with a transition  $l$  feet long, at  $v$  feet per second, equals  $v^3/lr$ . In Mr. W. H. Shortt's experience on the London and South-Western Railway the maximum rate of gain or loss of acceleration that will pass unnoticed is 1 foot per second in a second, so that  $l$ , the length of transition necessary, equals  $v^3/r$  feet.

Let  $V$  = velocity in miles per hour,  $R$  = radius in chains,  $L$  = length of transition in chains, then the maximum speed attained over the curve will be  $V = 11\sqrt{R}$  up to a speed of about 82 miles per hour, and  $L = \sqrt{R}$ , when  $R$  is not more than 54.3 chains. Where speeds as high as  $11\sqrt{R}$  are not probable, the length of transition may be  $\frac{0.000724 V^3}{R}$ , where  $V$  is the

maximum speed. The form of transition should satisfy the relation  $\frac{1}{\rho} = \lambda r l$ , where  $\rho$  = the radius at any point,  $\lambda$  is the length of transition traversed up to that point,  $r$  = radius of main curve, and  $l$  = the length of the transition. Mr. Glover, in a paper appearing in Vol. cxi. of the *Minutes of Proceedings of the Institution of Civil Engineers*, shows that the spiral  $\lambda = m\sqrt{\phi}$  completely satisfies this condition and is the simplest form of transition curve to use.

### QUESTIONS ON CHAPTER XXX.

1. How is the difference in length of the inner and outer rail on a railway curve dealt with in practice?
2. What practical expedient is adopted to neutralise the effect of centrifugal force on a railway curve?
3. Give a simple rule for the super-elevation of the outer rail on a curve.
4. Make a sketch showing the fixing of a rail in a cast-iron chair.
5. Explain what is meant by transition curves and the reason for their adoption.
6. What methods are available for enabling the rectangular wheel base of a vehicle to travel round a railway curve?

## CHAPTER XXXI.

Ranging a curve—By chain and offsets—By one theodolite—By two theodolites—Practical example—Points and crossings—Sidings.

**Ranging a curve.**—Ranging a curve consists in placing pegs at intervals along the centre line or railway from the tangent point where the curve leaves the straight. The distance from peg to peg depends upon the sharpness of the curve to some extent, and is independent of the position of the permanent stakes which have to be placed round the curve

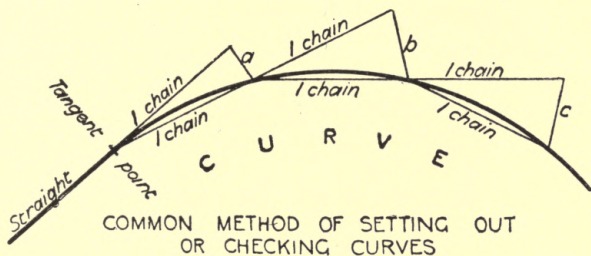

FIG. 201.—“Platelayers method” of setting out or checking curves.

at even distances from the commencement of the line, irrespective of the tangent points. The two things may be and sometimes are combined: the first point in the curve is then set out to range from the last permanent stake. Various simple methods may be first described, and then the more usual methods, as practised. Fig. 201 shows the “platelayer’s method” of setting out or checking curves, where

$$\frac{\text{ft. in. } 1 \text{ ch.}}{\text{rad. in. ch.}} = \text{ft. in offset } b, c, \text{ etc.}, \quad \frac{b}{2} = \text{ft. in offset } a.$$

Ex. 1. Say curve 3 chains radius (4 pole chain).

$$b = \frac{66}{3} = 22 \text{ feet.}$$

$$a = \frac{22}{2} = 11 \text{ feet.}$$

Ex. 2. Say curve 3 chains radius (100 ft. chain).

$$b = \frac{100}{3} = 33\frac{1}{3} \text{ feet.}$$

$$a = \frac{33}{2} = 16\frac{2}{3} \text{ feet.}$$

Theoretically, there are two closely allied methods which are shown with their formulæ in Figs. 202 and 203.

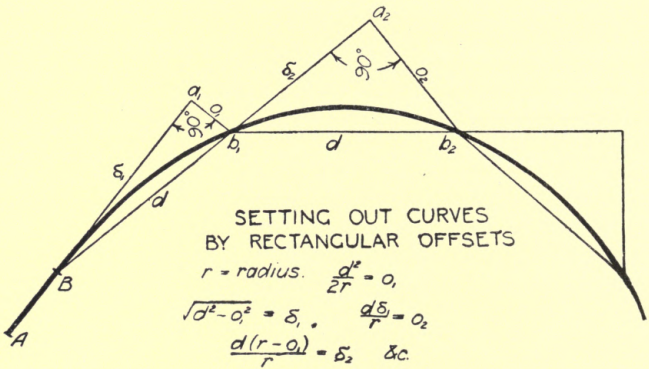

FIG. 202.

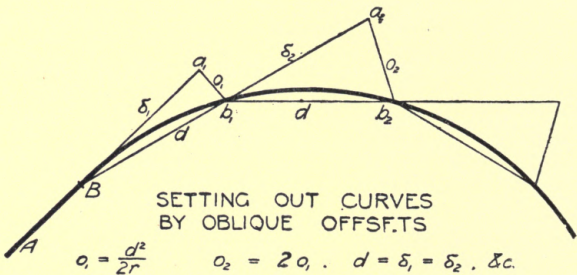

FIG. 203.

FIGS. 202 and 203.—Curves by chain and offsets.

Fig. 204 shows how a curve is placed on a bridge, and Fig. 205 the same principle extended to a curve on a viaduct. Fig. 206 shows a practical method of finding the radius of

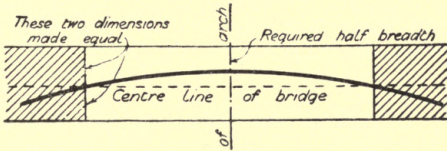

FIG. 204.

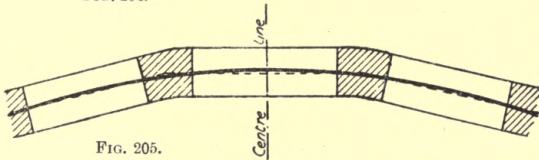

FIG. 205.

FIG. 204.—Curve on a bridge.

FIG. 205.—Curve on a viaduct.

an existing curve where  $C$  = length of chord on outer rail tangent to inner rail,  $g$  = width of gauge, then mean radius

$$= \frac{C^2}{8g}$$

The principle of setting out curves by angles of deflection is that equal arcs on the circumference of a circle subtend

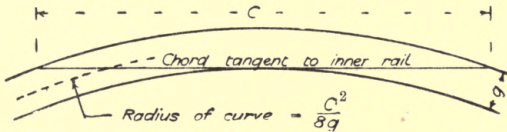

FIG. 206.—Finding radius of existing curve.

equal angles at any one point on the circumference. Let  $\delta$  = angle of deflection for an arc of  $a$  feet or chains, when the radius =  $r$  in same units, then  $\delta$  in minutes

$$= \frac{180 \times 60}{2\pi} \times \frac{a}{r} = 1718.873 \frac{a}{r}$$

When arc  $a > \frac{1}{20} r$ , chord  $c = a \left( 1 - \frac{a^2}{24r^2} \right)$ .

Where arc  $a \leq \frac{1}{20} r$ , chord  $c = a$  approx.

**Use of one theodolite.**—In setting out the angles of deflection by one theodolite as in Fig. 207, unless the curve

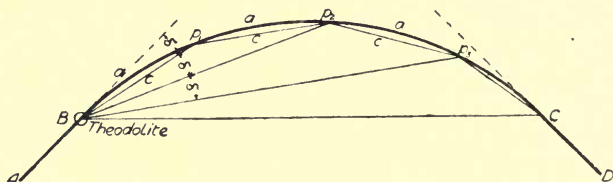

FIG. 207.—Setting out curves with one theodolite.

commences exactly at a given number of chains from the starting point of the railway, it will be necessary to make the first angle to fall upon the first chain-end on the curve. For instance, if the tangent point occurs at 8 m. 37 ch. 45 l., then  $100 - 45 = 55$ ,  $\frac{55}{100} \delta =$  first angle,  $\delta + \frac{55}{100} \delta =$  second angle, and so on.

The end of the curve may be treated in the same way. When two theodolites are used, as in Fig. 208, one is placed at

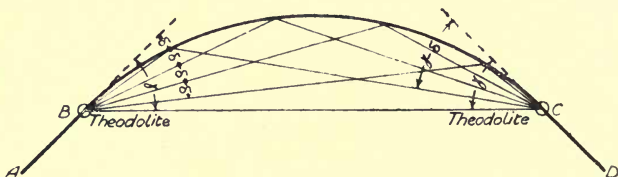

FIG. 208.—Setting out curves with two theodolites.

each tangent point, and the angles set off in an identical manner, the lines of sight intersecting at the successive chain ends,  $\delta$  being set off from one station and  $(\gamma - \delta)$  from the other,  $\gamma$  being the total angle of deflection.

A brief series of instructions for elementary field work, by means of which a couple of students, without further assist-

ance, could set out a curve with one theodolite, may prove useful at this point.

Required : Theodolite and legs, 6 poles, chain and arrows.

(1) Locate directions of straight portions, Fig. 209.

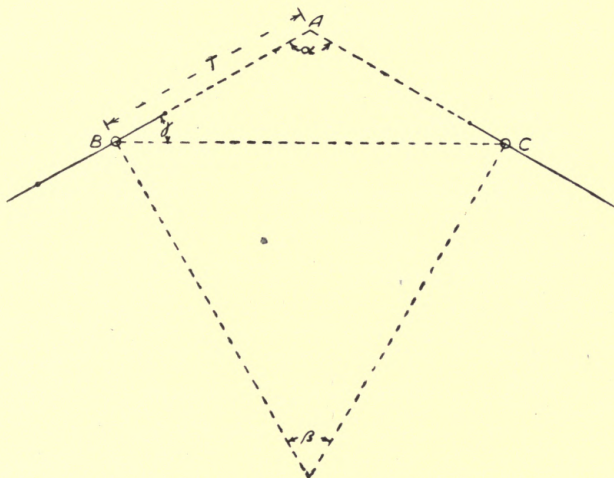

FIG. 209.—Practical example of setting out curve.

- (2) Decide radius, say 3 chains.
- (3) Find point of intersection (A).
- (4) Take angle of intersection ( $\alpha$ ), say  $120^\circ$ .
- (5) Find length of curve tangent (T)

$$= R \tan \frac{\beta}{2} = 3 \times \cdot 577 = 1\cdot73.$$

- (6) Chain and mark points B, C.
- (7) Say first tangent point B occurs at 3·17 on line, and stakes required 1 chain apart.
- (8) Owing to short radius, there will be appreciable difference between chord and arc.
- (9) The arc is to be set off in 1 chain lengths,

$$\therefore c = a \left( 1 - \frac{a^2}{24R^2} \right) = 1 \left( 1 - \frac{1^2}{24 \times 3^2} \right) = 0\cdot99537, \text{ say } 99\frac{1}{2} \text{ links.}$$

(10) Tangent point does not fall on chain end,

$$\therefore \text{first angle} = \frac{100 - 17}{100} \delta = 0.83\delta.$$

(11) And  $\delta = 28^\circ 38.8734'$   $\frac{\alpha}{R} = 9^\circ 33'$  for each angle after the first.

(12) First angle  $= 9^\circ 33' \times 0.83 = 7^\circ 55'$ ; first chord  $= 0.83 \times 0.99537 = 82\frac{1}{2}$  links.

(13) Second angle  $= 9^\circ 33' + 7^\circ 55' = 17^\circ 28'$ ; second chord,  $= 99\frac{1}{2}$  links.

(14) Third angle  $= 17^\circ 28' + 9^\circ 33' = 27^\circ 1'$ ; third chord  $= 99\frac{1}{2}$  links.

(15) Find whole deflection to see when to stop,

$$\gamma = 90 - \frac{\alpha}{2} = 30^\circ,$$

therefore now stop, as would be seen by peg at C in the field.

(16) To find length of remainder of curve, find whole length of curve and deduct distance traversed.

$$(17) \quad L = 0.0349066R \left( 90 - \frac{\alpha}{2} \right) = 3.141594,$$

$$3.14 - (0.83 + 1 + 1) = 0.31 = 31 \text{ links.}$$

100 - 31 = 69 links from tangent point to end of chain on straight.

The planning of the various junctions in the railway metals does not come under the purview of this work, but a very short description, with illustrations, of some of the arrangements may increase the usefulness of the book to young railway engineers. A simple turnout or pair of points or switches is shown in Fig. 210, and the crossing where the new

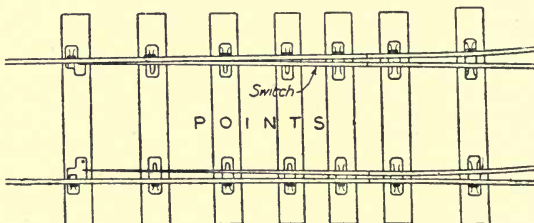

FIG. 210.—Pair of points or switches.



line leaves the old is shown in Fig. 211. A cross-over road is shown in Fig. 212, with trailing points, and it should be

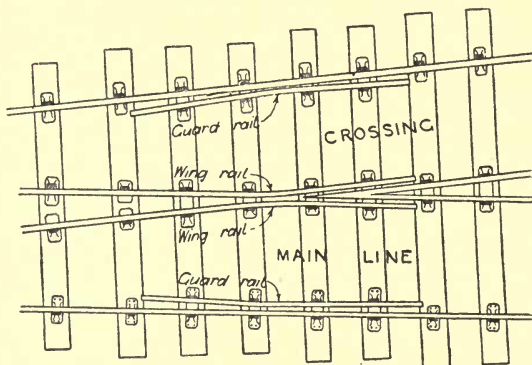

FIG. 211.—Crossing.

noted that facing points are not allowed on main lines. Fig. 213 shows the usual method of connecting sidings with

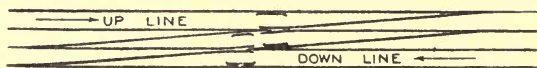

FIG. 212.—Cross-over road with trailing points.

the main lines of a railway, but the scale is unequal in length and breadth to keep within the limits of the page. Crossings

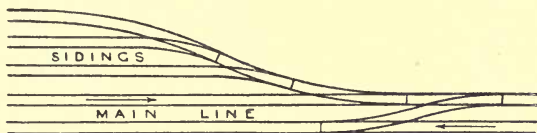

FIG 213.—Connection of sidings with main line.

should not be flatter than 1 in 8, or sharper than 1 in 6. Switches vary in length according to the radius of the turnout, from 10 to 20 feet.

**QUESTIONS ON CHAPTER XXXI.**

1. What is meant by "ranging a curve"?
2. Describe the simplest method you know of for ranging a curve of short radius.
3. How are bridges and viaducts arranged to allow railway curves to pass over them?
4. Explain the method of setting out a railway curve with two theodolites.
5. Make a sketch of a cross-over road in railway work, marking the direction of the traffic by arrows.
6. Explain a method of setting out a railway curve when the point of intersection of the tangents is inaccessible.

## CHAPTER XXXII.

Astronomical surveying—Finding true meridian—Celestial sphere—Longitude and local mean time—Astronomical, civil, and nautical time—Finding the latitude of a place.

**Astronomical surveying.**—It is often necessary for a surveyor to be able to locate his geographical position, in other words to find his latitude and longitude. This is a matter of some difficulty if exactitude is required, but it may be done approximately without very much trouble.

Roughly, the latitude of a place in the northern hemisphere is given by the mean altitude of the pole star, less 45 seconds for refraction, but to obtain it more correctly much subsidiary work is involved, which must first be explained.

To determine the meridian of a place, *i.e.* a true north and south line, there are various methods :

(*a*) Bisect the angle formed by the bearing of the sun at sunrise and sunset, when the lower limb is a semi-diameter above the horizon.

(*b*) Bisect the angle formed by the sun, or a star, in east and west positions of equal altitude.

(*c*) Take the mean between the eastern and western elongations of a circumpolar star.

(*d*) Find the direction when a vertical circle cuts both the pole star and the star Alioth in Ursa Major, otherwise "the shaft-horse of Charlie's wain," see Fig. 214.

The pole star is not precisely at the North Pole, but is nearer than any other star, being only 1 deg. 16 min. 42 sec. away from it and rotating round it, so that it crosses the meridian twice in twenty-four hours.

**Celestial sphere.**—Fig. 215 represents a celestial sphere as if it were a hollow globe surrounding the earth, with the visible heavens projected upon it. The point immediately

overhead is called the **zenith**, and the opposite point below is the **nadir**. **Culmination** is the term used for the passage of a celestial body across the meridian of a place, and in the northern hemisphere most of the bodies observed culminate southwards. **Declination** is the celestial term corresponding to the terrestrial one of latitude. Any celestial body would serve for observations of latitude as well as a star, but the

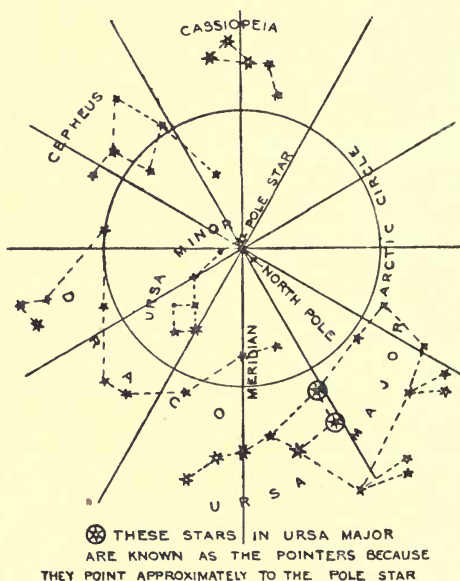

FIG. 214.—Position of the circumpolar stars.

declination of the bodies of the solar system varies from day to day and, in order to get the correct declination from the almanac, it is necessary to know the Greenwich mean time, whereas the declination of the fixed stars varies so little that no knowledge of longitude or time is required.

Let  $S$  (Fig. 215) = the apparent position of a body culminating to the south of the observer, then its declination will be north =  $SE$ , its altitude =  $HS$ , and the co-latitude =  $HE$ .

Let  $U$  be the position of a body culminating south and with a south declination, then  $EU = \text{declination}$ ,  $UH = \text{altitude}$ ,  $HE = \text{co-latitude}$ .

When a body culminates to the north of the observer above the pole,  $VR = \text{altitude}$ ,  $VP = \text{co-declination}$ ,  $PR = \text{latitude}$ ; and below the pole,  $V'R = \text{latitude}$ ,  $V'P = \text{co-declination}$ ,  $PR = \text{latitude}$ . Therefore,  $HE = SH - SE$ ,  $HE = EU + UH$ ,  $PR = VR - VP$ ,  $PR = V'R + V'P$ .

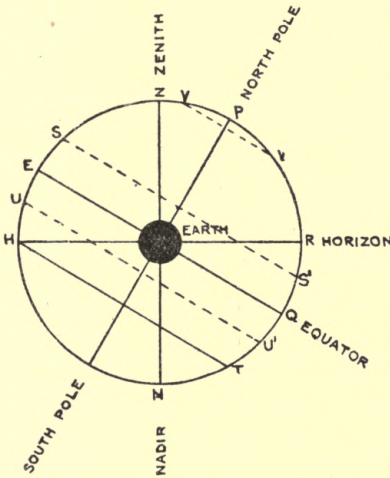

FIG. 215.—Diagram of celestial sphere.

The "prime vertical" is due east and west of the observer, *i.e.* at right angles to a meridian, and the apparent motion in altitude is greatest there.

**Longitude and local mean time.**—The centre of the sun passing the meridian, or the maximum altitude of the sun, gives approximate local noon. Longitude is determined by the difference between mean local time and Greenwich mean time. Noon is later on a west longitude and earlier on an east longitude, the difference in time being 4 minutes per degree.

Ex. Suppose the longitude is  $3^{\circ} 45' W.$ , then local mean time (noon) is  $4 \times 3\frac{45}{60} = 15$  min. after Greenwich mean time. Say *Whitaker's Almanac* under given date shows "sun  $2^m 22^s$  after clock," this is the "equation of time," and the apparent local time (noon) =  $12^h + 15^m + 2^m 22^s = 12^h 17^m 22^s$ . Or *vice versa*: Local noon =  $12^h 17^m 22^s$ , Greenwich time -  $2^m 22^s = +15$  min. Then 1 hour = 15 degrees of arc; therefore time  $\times 15 =$  longitude,  $15 \times 15 = 225$  min.,  $\frac{225}{60} = 3^{\circ} 45' W.$  longitude, or as is stated, longitude in time  $\times 15 =$  longitude in arc.

**Divisions of time.**—Now, as to time, Fig. 216 shows the relation, in order of succession, of the various divisions of time

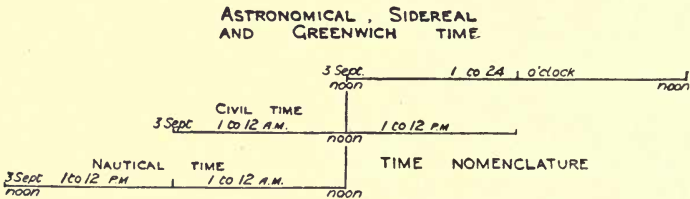

FIG. 216.—Relation of various divisions of time.

in use, with the name to each. It will be seen from this why the *Nautical Almanac* is said to be always a day behind. To find astronomical time from the civil time for P.M., make no change; for A.M., diminish the day of the month by 1 and add 12 to the hours. The **mean solar day** is the average interval between two consecutive passages of the sun over the same meridian, or true north and south line. The **apparent local day** is the actual interval between two consecutive passages of the sun over the meridian. A **sidereal day** is the interval between two successive transits of a star over the meridian of a place; and it is 3 min. 55.908 seconds less than a mean solar day. The **equation of time** in the *Nautical Almanac* is the difference between apparent and mean time, and is used for reducing apparent local to mean local time.

The time may be found by observation on a celestial body whose apparent position is given in the *Nautical Almanac*; or the transit of a star across the meridian gives true sidereal time of the locality from its **Right Ascension (R.A.)**. Right ascension is the angular distance measured along the equator

from the intersection of the equator and ecliptic at the vernal equinox (commonly called the first point of Aries, because it was originally there, but has since retrograded). Right ascension and declination are the two co-ordinates which define any point on a celestial sphere with regard to the equator as a fundamental plane, just as longitude and latitude define a terrestrial point. "Southing" is the time a heavenly body passes the meridian, or is the time of greatest altitude; right ascension may be called "Sidereal time of Southing."

**Finding the latitude of a place.**—A writer in *Building World* describes a method of obtaining the latitude approximately with a 2-foot rule and spirit level as follows:

"The instruments required are a fourfold rule and a small spirit level. Open the rule out its whole length, and raise up one fold at right angles to the other three. When the sun is on the meridian—that is, at local apparent noon—turn the rule to the sun so that the length of the shadow thrown by the upright fold may be measured on the three extended folds when the latter are held horizontally, as shown by the bubble of the small level, which must be placed on the extended part of the rule, in such a position that the eye may see at the same time the bubble at the centre of its run, and the end of the shadow. After a small amount of practice, this operation is easy to perform. The time of the sun's passage of the meridian can be obtained, for places near London, from *Whitaker's Almanac*. For any other place allowance should be made for the longitude at the rate of  $15^{\circ}$  to the hour. Where the longitude is unknown, the sun crosses the meridian at the time that it shows the shortest shadow, and the length of this shadow should be taken for calculating purposes."

The following is the calculation of latitude made from observations taken on February 6 (cloudy, with bright intervals). Rule, 2-foot fourfold; spirit level, 3 inch brass. Length of vertical fold, 6 inches; length of shortest shadow,  $14\frac{1}{2}$  inches.

$$\frac{6}{14\frac{1}{2}} = \frac{12}{29} = 0.4138, \text{ by reference table of natural tangents}$$

$0.4183 = \tan$  of  $22^{\circ} 30'$ , which is the altitude of sun. Then

Angular zenith distance from horizon	=	90° 0' 0"
Altitude of sun's centre	-	22° 30' 0"
		67° 30' 0"
Angular distance of sun from zenith	-	=
Sun's distance from celestial equator or declination south (from Whitaker)	}	= 15° 37' 45"
		=
Latitude of place of observation	-	N. 51° 37' 15"

Should the declination be north, it must be added to the sun's angular distance from the zenith instead of subtracted, to give the latitude. The latitude of the garden, where these observations were made, is, according to the Ordnance map (of 6 inches to the mile), 51° 37' 0" N.

With a theodolite, or other angular instrument of precision, latitude would be obtained practically by observing the meridian altitude of the sun as follows. Set up and level the theodolite ten minutes before apparent noon, put the dark glass on the eyepiece, direct the telescope to the sun, cut the lower edge with the horizontal wire, and follow the sun by the tangent screws as the altitude increases, stopping directly the highest point is reached. Note the reading of the vertical circle, and the remainder of the work is effected by reference and calculation.

The inversion in the telescope of the object and its movements must be duly remembered in making the observation.

Example. Plymouth, 9th Oct., 1901.

Observed altitude,	-	-	-	33° 6'
Add semi-diameter,	-	-	-	0° 16'
				33° 22'
Apparent altitude,	-	-	-	33° 22'
Deduct refraction,	-	-	-	0° 1'
				33° 21'
Add parallax,	-	-	-	0° 9'
				33° 30'
True altitude,	-	-	-	33° 30'
Add declination south,	-	-	-	6° 6'
				39° 36'
Co-latitude,	-	-	-	39° 36'
Latitude = (90 - co-latitude),	-	-	-	= 50° 24' N.



The semi-diameter, refraction, parallax and declination are taken from the *Nautical Almanac*. Note that a north declination must be deducted and a south declination added. The resulting latitude above is approximate only ; for exact work, the observations and corrections must be carried out to seconds, personal and instrumental errors allowed for, etc.

If, instead of a theodolite, a nautical sextant and artificial horizon be used, the angle taken will be a double altitude, to be divided by 2 before making the corrections.

**QUESTIONS ON CHAPTER XXXII.**

1. What is meant by the meridian of a place ?
2. What is the position of "the pole star" with regard to the North Pole ?
3. What is meant by local noon and how is it ascertained ?
4. What is the relationship between "solar," "sidereal," "nautical," and "Greenwich mean" time ?
5. What is meant by "the equation of time," and where may it be found ?
6. What are the items required in order to determine the latitude of a place ?

## CHAPTER XXXIII.

Signalling at a distance—The Morse alphabet and Universal code—Flag signalling—Flashing signals—Heliographing.

**Signalling at a distance.**—As surveyors may have to transmit signals to long distances they should learn the **Morse code and telepost alphabet**, or universal dot-and-dash code, consisting of long and short intervals indicated as below, in whatever way they may be produced.

### LETTERS.

A . -	K - . -	U . . -
B - . . .	L . - . .	V . . . -
C - . - .	M - - -	W . - - -
D - . .	N - .	X - . . .
E .	O - - - -	Y - . - - -
F . . - .	P . - - .	Z - - . . .
G - - - .	Q - - . - -	. (full stop) . . . . .
H . . . .	R . - . .	, (comma) . - . - -
I . .	S . . .	¶ (paragraph) - - - - -
J . - - - -	T -	& . . - - -

### FIGURES.

1 . - - - -	5 . . . . .	8 - - - . .
2 . . - - -	6 - . . . .	9 - - - - .
3 . . . - -	7 - - . . .	0 - - - - -
4 . . . . -		

To attract attention or to denote completion of message . . . . .  
Repeat . - - . .

**Flag signalling.**—A station pole or picket with a flag on it forms a good medium for transmitting signals over moderate distances, of say half a mile to a mile in daylight, without using binoculars. Holding the pole diagonally the flag should be moved sharply from the left to the right shoulder for dots and from the left shoulder to the ground for dashes.

**Heliographing.**—Sun-flash signals on the Morse code may be transmitted by heliograph over distances of several miles. Fig. 217 shows the method of carrying out the work. A is a mirror from which the sun's rays are reflected and B a screen for obscuring it in the direction the signals are to be transmitted. C is a horizontal bar carrying cross wires D. To adjust for signalling, the operator looks through a hole E in

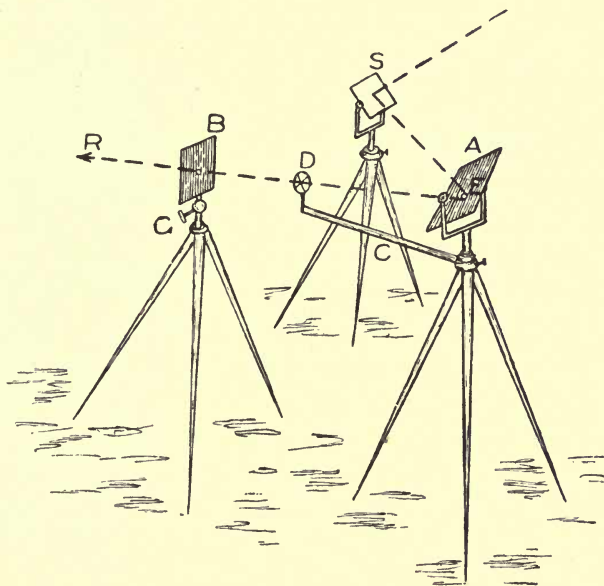

FIG. 217.—Sketch of operations in heliographing.

the mirror A, while an assistant adjusts the cross wires D until the point of intersection and the distant place to which the rays are to be directed are as nearly as possible in a straight line with observer's eye at E. The arm and wire frame are now fastened by means of screws. A white disc is next placed at the centre of the cross wires and a black one at the hole E. If the light reflected from A be now thrown upon B, a black dot will be seen upon it, this portion of the light having been

absorbed by the black disc. The screws of the signalling mirror are now turned until this shadow of the black disc is thrown on to the white one at the junction of the cross-wires. The rays now proceed in the required direction ER. The screen B is now adjusted so that the shadow of the white disc falls on the hole. The arm C being removed, everything is now ready and the screen B is operated by means of the thumb-screw G to give the required flashes. If the sun is so placed as to make it difficult to reflect its rays in the required direction a second mirror S is used to throw them on to A.

At night a signalling hand lamp, with flashing shutter, may be used for sending messages over moderate distances.

In case of necessity the signals can be communicated by any method of alternately shutting off and exposing a light of any kind, or by a series of knocks, it is well known that experienced operators can read off a transmitter by the sound only.

### QUESTIONS ON CHAPTER XXXIII.

1. Describe the principle of the Morse code.

2. Translate the following message :

... .. · · · | · · · · · | · · | · · | · · | · · | · · | · · | · · | · · |  
 || | · · · · | · · · · | · · | · · | · · | · · | · · | · · | · · | · · | · · | · · |

3. How are Morse signals transmitted by flag ?

4. Describe a heliograph and explain the method of using it ?

5. How can code signals be transmitted at night ?

6. What colours are seen most distinctly against the following back-grounds : (a) green trees, (b) dark earth mounds, (c) the sky ?

*her eye & I see*

## APPENDIX.

### EXAMINATION QUESTIONS IN LAND SURVEYING.

THE following questions have been given in various examinations, the source being named at the end of each. They are roughly classified in the order in which the subjects are dealt with in this book, and comprise the following list:— Admiralty Assistant Civil Engineers (12); Admiralty Assistant Surveyor (6); Architectural Association (8); Institution of Municipal and County Engineers (7); City and Guilds of London Institute (2); City of London College (56); Eastern Cadets (13); Engineers' Examinations, New South Wales (9); India Forest Service (9); Institute of Sanitary Engineers (4); Institution of Civil Engineers (68); Institution of Municipal Engineers (1); Public Works Department, India, Assistant Civil Engineers (18); Public Works Office, Ireland, Assistant Surveyor (6); Mason College, Birmingham (4); Owens College, Manchester (6); Royal Agricultural College, Cirencester (5); Royal Institute of British Architects (9); Society of Architects (8); Survey Department, Brisbane (13); Surveyors' Institution (4); Valuation Office, Ireland, Surveyor and Valuer (10); University College, London (4).

1. With 100-foot frontage what depth in feet will contain one acre? *(Arch. Assoc.)*

2. What is the length of a link in a 4-pole chain? Upon a scale of 88 feet to one inch what will be the length of 1 chain? *(Arch. Assoc.)*

3. Convert 17 acres 1 rood 20 perches statute measure into square yards. *(Surv. Inst.)*

4. Required in feet, the side of a square that shall contain an acre. *(R.I.B.A. Inter.)*

5. With the use of a chain of one hundred foot-links, how many square chains are there in one square mile? *(City Lond. Coll.)*

6. What is the scale of a map which shows 250 acres in 1 square inch? *(City Lond. Coll.)*

7. What is the object of measuring the area of a field without the aid of plotting? *(Owens Coll.)*

8. Distinguish between plotting scales and mechanical draughtsmen's scales, the latter designated as so many inches or parts of an inch to one foot. Also fully explain the expression "feet equal" upon a plotting scale. *(City Lond. Coll.)*

9. For what purpose are Ordnance Maps chiefly employed, and what are the comparative advantages of published maps which are drawn to the scale of (a) one inch to one mile, (b) six inches to one mile, (c)  $\frac{1}{2500}$  or 25·344 inches to one mile, (d) five feet to one mile, and (e)  $\frac{1}{250}$  or 10·56 feet to one mile? To which of the above Ordnance Maps is a scale of 88 divisions to one inch applicable and how is it applied? *(City Lond. Coll.)*

10. What are the representative fractions of the following scales: 5 chains to an inch, 6 inches to a mile? What scales are represented by the following fractions:— $\frac{1}{1056}$ ,  $\frac{2378}{1}$ , and  $\frac{1}{2500}$ ? *(India Forest Service.)*

11. If a plan is plotted to a scale of 3 chains to an inch, what proportion does the area of the plan bear to the ground? *(Surv. Inst.)*

12. Find the area in acres, roods and perches of a trapezium whose parallel sides are 45 links and 130 links, and base 3 chains 27 links. *(City Lond. Coll.)*

13. The outline of a certain piece of ground may be indicated by a square of 3 chains side, with an equilateral triangle on one side and a semi-circle on the opposite side. What is its area in acres, roods and perches? *(Arch. Assoc.)*

14. The distance from Hyde Park Corner to Cooper's Hill is 20 miles, and measures on map 2·75 inches. Draw the scale of the map showing 40 miles on right of zero, and 10 miles (subdivided into miles) on the left of it. *(Civ. Eng. P. W. D. India.)*

15. Make a scale of chains and links equivalent to 40 feet to 1 inch. *(City Lond. Coll.)*

16. A plan is to be plotted to a scale of 5 chains to an inch, but after it is completed it is found that the opposite side of the scale representing "feet equal" has been used by mistake. Draw the true scale of feet for the plan as plotted. *(India Forest Service.)*

17. In an old survey of 30 acres the chain used is found to have been 4·54 inches long. What is the correct area? *(Surv. Dept. Brisbane.)*

18. Having calculated the area of an estate from a plan drawn to a scale of one chain to the inch, upon the supposition that a

chain of foot-links (consisting of the usual 100 links) had been employed, the result was found to be 69 acres, 1 rood, 20 perches; but it was subsequently ascertained upon enquiry that Gunter's chain of 22 yards length had been employed for taking the measurements in the field. What is the correct area?

(*City Lond. Coll.*)

19. Upon what geometrical principles is land surveying based?

(*City Lond. Coll.*)

20. Describe the field-book used by land surveyors, and the method of using it.

(*City Lond. Coll.*)

21. How can an irregular four-sided figure be converted into a triangle, and what use is made in surveying of this principle?

(*City Lond. Coll.*)

22. Explain the use of the parallel ruler in reducing crooked fences to straight ones, and lay down a right-lined offset piece from the following notes; reduce it to a triangle by the parallel ruler, and find its contents both by calculation from the offsets and the casting of the ruler:—

To	B
751	0
550	150
400	51
250	99
50	75
000	0

From A range W.

(*R.I.B.A. Inter.*)

23. State Simpson's rule; and calculate the area contained between the fence and the line in the following example of distances and offsets:—0-0, 10-7, 20-13, 30-11, 40-9, 50-9, 60-10, 70-12, 80-14.

(*Owens Coll.*)

24. What are the chief scales of Ordnance maps? What information is given in Ordnance Survey Reference Books? What are the representative fractions corresponding to 24 inches to a mile, and 3 chains to 1 inch?

(*City Lond. Coll.*)

25. Take out the area of the wood numbered 1001 on the plan P, and reduce it to acres, roods and perches, etc. Show all your calculations.

(*Eastern Cadets.*)

26. A surveyor walks from A to B at 4 miles an hour, and he then walks back again by another road at 3 miles an hour; the last-named road is longer than the former by 2 miles. If he takes 9 hours in all, how long is each road?

(*Survey Dept. Brisbane.*)

27. A four-sided figure has two diagonals respectively 325 links and 450 links in length, with an angle of intersection of  $75^\circ$ , what is the area of the figure in square chains?

(*City Lond. Coll.*)

28. The area in acres, roods and poles [*sic*] is required of an irregular field, which was surveyed by running one line through it from end to end (A to B) with offsets taken as under.\* No plan to be drawn. (*City Guilds.*)

29. Give the formula for calculating the area of a triangular piece of land with sides respectively 300 chains, 236 chains and 126 chains long; state the area in acres and decimals of an acre. (*Mun. & County Eng.*)

30. The sides of a triangle are in the proportion of 5, 6 and 7, and the area is 100 square chains, what are the lengths of the sides? (*City Lond. Coll.*)

31. How many acres of horizontal ground would be covered by a bank 35 chains long, 7 yards wide at the top, 6 feet above the ground at one end and 27 feet above the ground at the other end, the slopes being two to one throughout? (*Inst. Mun. Eng.*)

32. Divide the triangle ABC into three equal portions by lines parallel to the side AB.  $AB = 2500$  links;  $AC = 2100$ ; and  $BC = 1800$ . Give the area of ABC and the distances  $Aa$ ,  $ab$ , and  $bC$ . (*Surv. Inst.*)

33. The sides of a triangular field containing  $x$  acres, are in the proportion  $a : b : c$ , find each side. (*Surv. Dept. Brisbane.*)

34. Write out a list of any instruments which are useful in enlarging or reducing maps or drawings, and describe shortly the two principal instruments. (*Valuation Office, Ireland.*)

35. Construct a diagonal scale of 3 inches to 1 mile, to read miles, furlongs and chains, and long enough to read 2 miles. (*Admiralty Civ. Eng.*)

36. In chaining the base line of a survey, a pond is met with crossing the line, which is too wide to be chained across; explain, with the help of a sketch, how the chaining can be accurately extended beyond the pond. (*Inst. C.E.*)

37. The length of a survey line was measured with a Gunter's chain and noted as 5000 links. It was re-measured with a 100-foot chain and noted as 3300 feet. The error of the Gunter's chain was  $+0.2$  link. What was the true length of the 100-foot chain? (*Inst. C.E.*)

38. Plot the survey, from the field-book accompanying this Paper, to a scale of 1 inch = 100 links. (*Inst. C.E.*)

\*The field-book part of many of the questions being often voluminous and of an ordinary character, or containing diagrams, has been omitted here and in other similar questions. Such questions serve, however, to show what is expected of candidates in the Examinations concerned.



39. Describe the manner in which the light band chain suspended free of the ground, is used. What degree of accuracy may be expected from the use of this system of measurement? (*Inst. C.E.*)

40. How are base lines measured by steel tapes? What should be the length of the tape? What precautions should be taken during the work and what accuracy would you expect? (*Inst. C.E.*)

41. The accompanying extract from the pages of a field-book represents the survey of two adjoining fields. A plan is to be drawn out of these fields and the exact area comprised within the base lines of the survey is to be ascertained. (*Inst. C.E.*)

42. State briefly the points to be attended to in selecting positions for the stations of a chain survey; also the precautions to be taken to secure accuracy in chaining the lines. (*Inst. C.E.*)

43. The following perpendicular offsets were taken, at consecutive intervals of 20 feet, from a straight line to a wavy boundary: 9, 15, 12.3, 17, 5.2, 9.4, 7. Find the area between the straight line and the boundary line by Simpson's rule. (*Inst. C.E.*)

44. Distinguish between compensating and cumulative errors in chaining. A field was measured with a chain 0.3 of a link too long, the area thus found was 30 acres. What is the true area? (*Inst. C.E.*)

45. One of the lines of a chain survey crosses a pond. Give three methods of finding the distance across the pond without using any instruments for measuring angles. (*Inst. C.E.*)

46. Describe a Gunter's chain; state what precautions are necessary to ensure accurate work. (*Mun. and County Eng.*)

47. What is the proper presumption as to where the dividing line between two estates is situated; (a) where separated by a hedge and ditch; (b) where separated by a hedge and ditch on either side of the hedge; (c) where separated by a fence? (*Valuation Off. Ireland.*)

48. What is the present "magnetic variation," and what use is made of it in land surveying? (*Arch Assoc.*)

49. Describe a complete set of instruments required by a land surveyor in field work, giving the size of each instrument where desirable. (*Valuation Off. Ireland.*)

50. Describe the methods of lineal measurement (a) with short tapes; (b) with long ribands. (*Surv. Dept. Brisbane.*)

51. Compare the relative merits of a Gunter's chain, 66 feet long, with a chain of 100 foot-links, and state under what circumstances the use of the one is to be preferred to the other. (*City Lond. Coll.*)

52. Describe Gunter's chain, and state for what purpose it is of the prescribed length; to what branch of surveying is it particularly

applicable? Also, describe the 100-foot chain and its divisions; how many arrows are attached to each chain, and what is their use? (*Civ. Eng. P. W. D. India.*)

53. Show by a sketch the usual method of taking offset measurements to a fence boundary, and any variation you would adopt to accurately delineate the intersection of one fence with another fence. (*City Lond. Coll.*)

54. Explain the object of a base line. What is the purpose of a tie line, and what is meant by an offset? (*City Lond. Coll.*)

55. How are the lines of a chain survey fixed in position, and how is the correctness of the work tested? What is meant by "tying" the lines? Give a sketch. (*Mun. and County Eng.*)

56. Can you make a survey without using any instrument for measuring angles? If so, prove the correctness of the method you would employ. (*Val. Off. Ireland.*)

57. What considerations would guide you as to the limit of length of an ordinary offset in making a survey? What considerations would determine the number of offsets which you would deem it necessary to take, and what value would you attach to a split offset scale, when plotting; that is, an offset scale with the zero in the centre. (*City Lond. Coll.*)

58. In what manner would you record measurements from a base line to some well defined point in a survey, such as the corner of a building, which it is, of course, necessary to fix in position most accurately. (*City Lond. Coll.*)

59. What is a "north-point"? What is meant by "magnetic variation"? (*City Lond. Coll.*)

60. Sketch the cross section through a hedge and ditch between two fields, and mark the point of the usual boundary. What is the usual allowance from the centre of hedge to brow of ditch when they separate the property of two different owners? (*Soc. Archs.*)

61. Sketch an irregular five-sided field, the longest side, about 3 inches long, being taken as the base. Rule on the chain lines you would use in making the survey, assuming the scale to be 2 chains to 1 inch, and give the field-book entries, with offsets for the base line. (*Soc. Archs.*)

62. Show by sketch, and describe how you would continue a chain line across a circular pond 100 feet diameter. (*Soc. Archs.*)

63. Describe the method of setting the poles and chaining over rising ground when the station pole at one end cannot be seen from the other. (*Soc. Archs.*)

64. How would you proceed to set out a straight line, between two points, the intervening land being too high to allow of your sighting from one to the other. (*Assist. Surv. P. W. O. Ireland.*)

65. Explain how you would range out a base line over a hill of moderate slope, and give a sketch showing how you would proceed in order to measure the length of this base line with a chain 100 feet long. (*City Lond. Coll.*)

66. Describe how perpendiculars to a chain line are set out in the field. (*R.I.B.A. Inter.*)

67. Describe a means of erecting a perpendicular to a base line with the use of a chain only; and the method you would take with the chain, to check the direction of the perpendicular in the field, if you had any fear of your chain being out of adjustment. (*City Lond. Coll.*)

68. Show by a sketch how you would continue a station line past an obstacle, such as a tree. (*Owens Coll.*)

69. How would you chain past an obstruction in the field when (a) it can be seen over; (b) it cannot be seen over? (*Arch. Assoc.*)

70. Explain and illustrate by diagram how you would obtain the distance to an inaccessible point, using only chain and poles. (*Surv. Inst.*)

71. Illustrate and describe in what way you would produce a survey line obstructed by a large tree or building? (*Surv. Inst.*)

72. In chaining a line up or down a slope, would you consider the total length accurately arrived at by stepping with the chain in short lengths, and using a dropping arrow or a plumb-bob? Do you prefer a plumb-bob being employed to a heavy dropping arrow, and if so, state your reason. (*City Lond. Coll.*)

73. Give a sketch showing in what manner the length of a base line may be accurately measured when required to be continued (1) over a broad stone wall, 5 feet high; (2) over a thick-set hedged fence; (3) over a hill of moderately steep slope; and (4) across a pond more than one chain wide. (*City Lond. Coll.*)

74. State three ways of carrying a chain line past an obstruction, and describe how the width of a river can be determined without actually measuring across it. (*R.I.B.A. Inter.*)

75. Give a sketch showing in what manner the length of a base line may be accurately measured when needed to be continued (1) over a broad stone wall, 5 feet high; (2) over a thick hedge fence; (3) over a hill of moderately steep slope; (4) across a pond; or (5) round a detached house. (*City Lond. Coll.*)

76. How may the ranging and chaining of a base line in open country be conducted in each of the following cases, with the use of the chain and ranging rods only: (a) when the first station and the direction of the line is obstructed by a building which can only be passed upon one side of the line; (b) when both stations are given,

but the station at one end of the line cannot be seen from the station at the other end of the line, owing to the hilly nature of the district. *(City Lond. Coll.)*

77. Two lines, AB and CB, meet at an inaccessible point, D, in the centre of a large lake. Show how to find the position of point D without the aid of any regular instrument.

*(India Forest Service.)*

78. How would you ascertain the distance of a point in the middle of a broad river, 1st, with a chain; 2nd, without anything but a few pickets?

*(Civ. Eng. P. W. D. India.)*

79. From the accompanying notes (a) lay down the survey lines and plot the plan to a scale of 2 chains to an inch. Also find the area of the field.

*(Assist. Surv. P. W. O. Ireland.)*

80. The accompanying sketch represents two level fields to a scale of 3 chains to 1 inch. Show upon it the lines you would use to make a survey.

*(City Lond. Coll.)*

81. Plot the following field notes of the survey of a lake to a scale of 1 chain to 1 inch, and give the area of the lake in square yards.

*(Arch. Assoc.)*

82. Required from the following field notes, the plan and area of a wood, two of the fences of which are straight.

*(R. I. B. A. Inter.)*

83. From the field notes given, lay down the survey lines, and plot a plan to a scale of 2 chains to an inch.

*(Surv. Inst.)*

84. What are the instruments in general use for surveying? Mention the object of each.

*(Eastern Cadets.)*

85. Measure the acreage of the lake on the plan A. Show your field-book, with all the notes you would take in making the survey of the lake.

*(Eastern Cadets.)*

86. Draw on the plan A the main survey lines you would use in the field to enable you to make this plan, rule a form of field-book, and enter up the field notes you would take on any one of your main lines.

*(Val. Off. Ireland.)*

87. Enlarge the lower half of Plan A to double its present scale. You are recommended to ink in and completely finish part as a specimen of your work before completing the whole enlargement.

*(Val. Off. Ireland.)*

88. Draw two adjoining irregular fields, show the survey lines on same which you would run, and enter up your field notes in such a way that you would reproduce your plan from the notes. The measurements may be assumed.

*(Admiralty Assist. C. E.)*

89. A survey with the chain only is to be made from the outside of the wood shown on the accompanying plan A. Show in red on the plan all the lines you would set out and chain for this purpose.

*(India Forest Service.)*

90. Enter in pencil in the "Field Book" supplied to you all the notes you would make in chaining the lines in the last question, so as to enable you to plot your survey at any future time.

*(Indian Forest Service.)*

91. Make a sketch of the accompanying plan, sufficiently accurate to indicate upon the sketch the position in which you would probably lay out the base lines. Number these lines and letter the main stations without filling in all the detail, which is drawn to a scale of 3 chains to 1 inch, supposing the ground to be intersected by railway which is partly in cutting and partly in embankment as shown upon the plan.

*(City Lond. Coll.)*

92. Given a plan in which the base lines CA, AD, DB, BC, and AB are run and chained, indicate what other base lines you would run to complete the survey.

*(City Lond. Coll.)*

93. Make a sketch-copy of the accompanying plan, showing by fine lines, how you would run and connect your base lines for making a complete survey of the ground. Rule a form of field-book, and enter in it a few of the notes you would make in conducting the survey, indicating both upon the plan and the field-book all "check lines" and "tie lines."

*(City Lond. Coll.)*

94. Assume you had to make a survey similar to that shown on plan A; mark in red on this plan the survey lines you would take, and calculate the area of field No. 3 on plan A. Enter up in the form of a field-book the notes you would take in the field of the main survey lines required to produce plan A.

*(Admiralty Assist. C.E.)*

95. Taking AB as a base line on plan P, show by fine red lines, on the plan, all the lines you would set out and measure in order to make a plan of the field numbered 1000 with the chain only and without entering the wood. Rule a form of field-book and enter in it all the notes you would make in chaining the base line AB, recording also the stations on it.

*(Eastern Cadets.)*

96. On the plan given draw in pencil the lines it would be necessary to run to enable you to make a complete survey with the chain only.

*(Surv. Inst.)*

97. Compute the areas of the enclosures in the corner of the plan above mentioned, giving the result in acres, roods and perches; one of these enclosures must be computed by means of the ordinary plotting scale, and the other in any way the candidate may elect. (Enclosure No. 1, if well done and a correct answer arrived at by the ordinary plotting scale, will carry full marks.)

*(Surv. Inst.)*

98. Having a pole fixed at the points marked A and B upon the plan show how you could ascertain the width of the river between A and B, without the use of an angular instrument, supposing the

distance greater than one chain across. Show by dotted lines upon the plan, the direction and position of such longitudinal and transverse sections as you might consider it advisable to take, in order to give a general idea of the levels of the ground. Also indicate by marks thus +, the positions of any extra spot levels which might be added, and number the section lines in order.

(*City Lond. Coll.*)

99. Describe the clinometer. When is it used by land surveyors to great advantage? (*Survey Dept. Brisbane.*)

100. For what uses is a clinometer valuable? (*City Lond. Coll.*)

101. Explain the construction and use of an optical square. (*City Lond. Coll.*)

102. Explain by a sketch the construction and use of a simple cross staff. (*City Lond. Coll.*)

103. Explain the use of a planimeter and the application of its readings to a plan, drawn to a scale of 6 inches = 1 mile, when the area of an enclosure is required. (*City Lond. Coll.*)

104. Explain the construction and adjustments of the box sextant. Point out the errors to which the instrument is liable, from its construction and in use. (*Inst. C.E.*)

105. Explain the principle and use of a box sextant and any difficulty there is in adjusting it. (*City Lond. Coll.*)

106. How can you ascertain whether a pocket sextant is in adjustment, and why, in trying its adjustment, should the object observed be at least half-a-mile away? The areas of the theodolite and sextant both read to minutes, why is the former the more accurate instrument? (*Civ. Eng. P.W.D. India.*)

107. Show with a diagram, that the angle measured by the sextant is only half of that actually subtended by the objects observed. (*Civ. Eng. P.W.D. India.*)

108. State the reasons why the sextant is but seldom used for ordinary surveying. (*Owens Coll.*)

109. How can you ascertain your position on a plan of any ground by the aid of the sextant? (*Civ. Eng. P.W.D. India.*)

110. Explain the principle of the Vernier scale, and illustrate it with a sketch of a Vernier reading to half minutes, to any primary scale you like. (*City Lond. Coll.*)

111. Define the meanings of the words "bearing" and "azimuth." What is, approximately, the variation of the magnetic needle at Greenwich? Give its direction with regard to the true meridian. (*Inst. C.E.*)

112. Three sides of a quadrilateral field were surveyed by compass and chain and their bearings and lengths were determined as

given in the following notes.\* Assuming that the work has been correctly done, calculate the bearing and length of the fourth side.

(Inst. C.E.)

113. A prismatic compass traverse closes on its starting point. In plotting the field observations you find there is a closing error. How would you eliminate it? The bearings have been corrected for local attraction before plotting.

(Inst. C.E.)

114. The latitude of B from A is 106.42 feet N. and its departure is 273.62 feet W. What is the bearing of the line AB?

(Inst. C.E.)

115. Define magnetic declination. Write down its present value in one of the following places:—London, Edinburgh, Dublin, Bombay, Cape Town, Toronto. What are the variations to which this quantity is subject?

(Inst. C.E.)

116. A piece of waste land has been marked out by pegs at its six corners, A, B, C, D, E, and F, and the following bearings, angles, and measurements have been taken: A is west-north-west of F, and north-east of B; angles BAC  $21^{\circ} 15'$ , CAD  $24^{\circ} 15'$ , DAE  $33^{\circ} 30'$ , BCA  $30^{\circ} 15'$ , ACD  $107^{\circ}$ , DEA  $86^{\circ} 15'$ , AEF  $30^{\circ} 15'$ , and AB = 15.6 chains. Make a plan of the piece of land, and ascertain the length of straight fencing between the corners required to enclose it and the area.

(Inst. C.E.)

117. From a point A on the surface of the ground a drained tunnel is to be driven in a straight line rising along a grade of 1 in 100 to meet a shaft which is sunk centrally round a point B. A and B have been connected by the traverse.

A 1 = 225 feet N.  $43^{\circ}$  W.

1 2 = 310 feet N.  $15\frac{1}{2}^{\circ}$  W.

B 2 = 415 feet N.  $53^{\circ}$  E.

and the level of B is 85.37 feet above formation level of the tunnel at A. Find the length of the tunnel from A to the centre of the shaft and the depth of its formation level at B.

(Inst. C.E.)

118. Define "magnetic declination" and write short notes on: Secular variation and diurnal variation of the declination, isogonic lines and agonic lines.

(Inst. C.E.)

119. What is meant by "error in closure" in a traverse survey? Describe clearly the different methods used in adjusting this error.

(Inst. C.E.)

120. Describe a method of determining the declination of the magnetic needle. What is approximately the declination about London at present?

(Inst. C.E.)

121. What is meant by the three-point problem? How is it solved mechanically in plane-table work?

(Inst. C.E.)

\* See previous footnote.

122. Describe the method by which any definite point on a plane-table can be centred over a particular station on the ground and discuss the question as to the necessity for accurately centering the table. *(Inst. C.E.)*

123. Sketch the form of level staff you are most familiar with, showing the principle upon which its graduations are marked for reading, and state the precautions to be observed by the staff holder to ensure accuracy in your records, when at work over undulatory ground. *(City Lond. Coll.)*

124. Describe the various instruments used in levelling, and the way in which each is used. Illustrate by sketches. *(R.I.B.A. Inter.)*

125. Describe the principal points of difference between a Y level and a dumpy level, and the advantages classified for each type of instrument. *(City Lond. Coll.)*

126. What are the adjustments of a level and how would you test it? *(Eastern Cadets.)*

127. What is meant by the diaphragm of an ordinary dumpy level? Explain by an illustrative sketch its usual mode of attachment within the telescope of a level, and its use in adjusting the instrument for collimation. *(City Lond. Coll.)*

128. If on looking through a level the crosshairs were indistinct what part of the instrument would require adjustment? State also what other test besides that of distinctness can be applied for this adjustment. *(Owens Coll.)*

129. If you were able to choose, would you make any special arrangement as to the relative distances of the back-staff and fore-staff from your level? State your reasons. *(Assist. Surv. P.W.O. Ireland.)*

130. In taking accurate levels over a series of stakes, how would you work to neutralise errors of "curvature" and "collimation," and why? *(Mun. and County Eng.)*

131. Describe briefly the setting up and reading of a dumpy level. What influence has the height of the telescope on the reading, (a) in simple levelling, (b) in compound levelling? *(Arch. Assoc.)*

132. Briefly describe how a dumpy level is tested to ascertain if it is in adjustment. *(R.I.B.A. Inter.)*

133. What is the line of collimation in a level? How would you adjust a dumpy level for collimation? What is the nature of the error likely to occur from using a level that is not in adjustment? Illustrate your answer by a sketch. *(Eastern Cadets.)*

134. Explain the meaning of the terms "parallax" and "collimation" in the level, and describe how a dumpy level may have



these adjustments tested either in a well paved road or upon an open field. *(City Lond. Coll.)*

135. Describe the operation of levelling by means of a dumpy level. *(Val. Off. Ireland.)*

136. Show in large detail, 1 foot in length of a levelling staff, and sketch the spring joint in common use between the various lengths of the staff. *(Admiralty Assist. Civ. Eng.)*

137. What are the various forms of levels? Explain the kind you prefer and your reasons for the preference. *(Admiralty Assist. Civ. Eng.)*

138. Show a section through the telescope of a level and state how you would test and adjust a dumpy level. *(Admiralty Assist. Civ. Eng.)*

139. How is the spirit level made parallel with the line of collimation in a Gravatt's level? *(Roy. Agr. Col. Cirencester.)*

140. Before commencing to take a series of levels briefly describe how you would ascertain if your level was in adjustment. *(Surv. Inst.)*

141. Describe the "dumpy level," and how it is set up for use. Give a specimen of a "level book," showing "back," "fore," and "intermediate" sights and the mode of getting the "reduced levels." *(Mun. and County Eng.)*

142. How would you test the object glass in a telescope; and give an explanation of the effect known as parallax. *(Surv. Dept. Brisbane.)*

143. Describe carefully the setting up and adjusting of the level before taking a reading. *(Soc. Arch.)*

144. Sketch the divisions of a level staff from 3·85 to 4·15 and mark a line through 4·01. *(Soc. Arch.)*

145. What is meant by a level line? And what is the meaning of each of the following terms: Ordnance datum, bench mark, mean sea level, Trinity high water, gradient? Also describe in what manner the datum level should be recorded upon a parliamentary plan and section. *(City Lond. Coll.)*

146. Illustrate by diagram the difference between "true" and "apparent" level, and give a rule for determining same. *(Surv. Inst.)*

147. Explain the effect of the curvature of the earth on levelling operations. When is a correction on its account necessary, and what, in general terms, is the amount of such correction? Is it an additive or subtractive quantity? What is the correction for curvature due to a distance of 29,040 feet? *(Civ. Eng. P.W.D. India.)*

148. What do you understand by "refraction"? Are the effects constant or variable, and to what cause are they attributable?

What is the mean correction ordinarily applied on its account to an observed angle? And how, in practice, may the effects of curvature and refraction ordinarily be obviated? (*Civ. Eng. P.W.D. India.*)

149. Give the full entries in a level book for three settings of the level, reading from a bench mark. (*Soc. Arch.*)

150. What is meant by an intermediate sight in taking levels? And, with the use of a level book in which a column headed "intermediate" is introduced, in what way are the entries in that column dealt with, when making up and checking a page of reduced levels? (*City Lond. Coll.*)

151. Rule a page of level book, and give the names of the several columns that you would adopt, stating in which columns the entries are made in the field and which columns are used for plotting the levels. How may accuracy in the book work be secured? What kind of notes would you enter in the field upon the columns or page of remarks? (*City Lond. Coll.*)

152. In a series of levels, if the first back sight read 3.25 on an Ordnance bench mark of 28.30, the sum of the back sights be 12.95 and the fore sights 17.20, what will be the Ordnance reading of the last fore sight? (*City Lond. Coll.*)

153. What form of level book do you prefer? Sketch a page, giving the headings and their use, and state why you prefer this method to other systems with which you may be acquainted. (*City Lond. Coll.*)

154. Reduce the following levels and plot them to a scale of  $\frac{1}{2}$  inch to 100 feet for horizontals and  $\frac{1}{2}$  inch to 10 feet for verticals. (*Roy. Agr. Coll. Cirencester.*)

155. Rule a form of level book, enter 8 or 10 imaginary readings and complete the column, reading on the staff 5.43 on a bench mark, 103.65 above datum, and without moving the level, 4.07 on the first point in the section. The level afterwards to be moved two or three times to complete the section.

(*Assist. Surv. P.W.O. Ireland.*)

156. Rule a form of level book, classify the following staff readings, and work out the reduced levels upon a datum of 60 feet below the point A of commencement, where the level staff was first held when taking the levels:

At point A,	back sight reads	2.20 ft.		
"    B,	fore sight reads	12.09 ft.,	back sight reads	1.11 ft.
"    C,	"          "	11.70 ft.,	"          "	2.30 ft.
"    D,	"          "	7.51 ft.,	"          "	8.28 ft.
"    E,	"          "	1.90 ft.,	"          "	11.00 ft.
"    F,	"          "	3.30 ft.,	"          "	6.37 ft.
"    G,	"          "	8.81 ft.,	"          "	2.39 ft.
"    H,	"          "	8.92 ft.		( <i>City Lond. Coll.</i> )

157. In running a line of check levels the staff readings in feet were as follows : back sights 4·23, 2·75, 5·31, 9·42, 11·24, 8·78, 7·29, 10·34 ; fore sights 3·90, 11·07, 10·25, 6·38, 2·50, 1·33, 6·44, 6·11. The first reading was taken on a bench mark, 70·36 feet above Ordnance datum. Rule a form of level book on the sheet of paper provided for the purpose and enter in it the above readings in their proper columns. Make up the level book and check it completely.

(*India Forest Service.*)

158. Describe the operation of levelling and a form of level book. Enter up sample figures in each column of the level book and show how the arithmetical work can be checked.

(*Admiralty Assist. Civ. Eng.*)

159. Show how you would arrange the columns in a level book suitable for obtaining the cross sections along the line of a proposed road. Give an example.

(*Inst. C.E.*)

160. Explain how it is possible to eliminate the effects of curvature and refraction in levelling across a wide river by the use of two levels.

(*Inst. C.E.*)

161. Show clearly the nature of the corrections for curvature and refraction in taking long sights in levelling. What correction should be applied for a sight of 1 mile, assuming that the correction for refraction is one-sixth of that for curvature?

(*Inst. C.E.*)

162. Give a specimen page of a levelling book, and describe the method of checking to be observed in cases where extreme accuracy is desirable.

(*Mun. and County Eng.*)

163. In levelling across the river Severn, the horizontal wire cuts the underside of a signboard, 14·35 feet above the level of the ground, the distance being 2 miles 5 chains from the instrument ; the back sight to a bench mark close by was 7·25 feet, the level of the bench mark being 52·80. Determine the level of the ground at the signboard.

(*Surv. Inst.*)

164. Reduce the entries in the following level book, and show how you would check the arithmetical operations.

(*Inst. C.E.*)

165. Plot the following section to a horizontal scale of 2 chains to an inch, and to a vertical scale of 20 feet to an inch.

(*Surv. Inst.*)

166. Cast up the following level book, and make a rough sketch of the section.

(*Owens Coll.*)

167. Reduce the following levels, and plot them to a scale of 1 chain to 1 inch horizontal, and 10 feet to 1 inch vertical.

(*Arch. Assoc.*)

168. Plot the following section to a scale of 2 chains to the inch, horizontal, and 20 feet to an inch, vertical. Datum line, 100 feet below the bench mark A.

(*R.I.B.A. Inter.*)

169. Make up the level book on the back of this sheet, and plot the same to scales of 2 chains to 1 inch, and 10 feet to 1 inch.

(*Surv. Inst.*)

170. Show by a sketch what is meant by contour lines, and describe how you would obtain them in the field.

(*Soc. Arch.*)

171. An engineer's pupil runs a line of levels along some miles of a road with steep gradients. On checking the work, an experienced surveyor finds that he makes the gradients flatter than the pupil did. What is the most likely cause of the discrepancy, and what precautions have probably been overlooked by the pupil?

(*Inst. C.E.*)

172. What is a contoured survey? Describe the field work required for such a survey.

(*Eastern Cadets.*)

173. State what you think about contouring and cross-sectioning the land to be traversed. Compare railways, roads and canals in this respect.

(*Mason Coll.*)

174. What do you understand by contour lines? How do you trace them upon the ground with a spirit level or theodolite? and for what purpose and with what objects are contoured surveys ordinarily executed?

(*Civ. Eng. P.W.D. India.*)

175. Describe a hand-level which may be used in surveying. Show clearly by the aid of sketches and specimen field-notes, how it may be used to determine the contours on a route along which the surface levels have been found at every station.

(*Inst. C.E.*)

176. You have to make a longitudinal section along a centre line which has been pegged out in a field. What instruments, equipment, and labour would you take into the field with you?

(*Inst. C.E.*)

177. Explain the method of tracing contours with a dumpy level. At what vertical distances apart may contour lines be most usefully applied, according to the scale of the plan, the nature of the country, and the purpose for which such contours are usually required.

(*City Lond. Coll.*)

178. The sketch herewith is a portion of a map with contour lines, the figures indicating the height in feet above a certain datum level. Sketch freehand on your paper a set of contour lines approximately similar to them, then draw a section by the vertical plane PP. The vertical scale may be taken 20 feet to an inch.

(*City Guilds Cent. Inst.*)

179. What is a contour survey? How would you make one of a mountain, say, 1000 feet high? Illustrate your answer by sketches.

(*Admiralty Assist. Civ. Eng.*)

180. How would you make a contour survey? (*Eastern Cadets.*)

181. Describe what precautions you would take if you were to use an aneroid barometer to determine the difference in elevation between two places. Note the accuracy you would expect in any particular case. Explain what is meant by saying that the instrument is "compensated," and why a "correction" for temperature has to be applied. *(Inst. C.E.)*

182. You are given a 6-inch Ordnance map, with contours of 100 feet vertical interval. How would you interpolate contours at 25 feet interval, using a clinometer? *(Inst. C.E.)*

183. On some of the Ordnance Survey maps, two kinds of contours are shown, viz. : instrumental contours and interpolated contours. How have these been located? *(Inst. C.E.)*

184. It is required to find the difference of level of two pegs on opposite banks of a river, and it is known that the collimation line of the level you have to use is out of adjustment. How would you find the difference of level required? *(Inst. C.E.)*

185. Give an account of the methods by which the heights of mountains can be ascertained, in cases in which the ordinary process of levelling is inapplicable. *(Inst. C.E.)*

186. What is meant by the variation of the needle?  
*(R.I.B.A. Inter.)*

187. What are the meanings of the terms, magnetic meridian and variation of the compass? Explain the method of finding the latter in the field, and state how a meridian line can be marked out on the ground without the aid of any instrument, with sufficient accuracy for common purposes. *(Civ. Eng. P.W.D. India.)*

188. Sketch and describe a prismatic compass.  
*(Val. Off. Ireland.)*

189. Describe the method of using the prismatic compass. State how you would survey a road with it. Also, explain the method of finding your station by interpolation, by means of two or more stations already fixed. *(Civ. Eng. P.W.D. India.)*

190. What is meant by surveying on "the meridian and perpendicular system"? *(City Lond. Coll.)*

191. Having taken the angle with a theodolite set up over a station point at the intersection of two base lines, show how their relative positions may be accurately plotted with the aid of trigonometrical tables, and without the use of a protractor. *(City Lond. Coll.)*

192. In a traverse survey, state what steps you would adopt to ensure accuracy in recording the value of the angles between your base lines in the field with the use of a theodolite. *(City Lond. Coll.)*

193. Plot to a scale of 3 chains to an inch, the following traverse round a wood, and scale the length of AF.

A to B,	length,	1075	bearing	343·15
B "	C,	"	810	" 51·10
C "	D,	"	660	" 104·56
D "	E,	"	745	" 139·14
E "	F,	"	1000	" 188·17

(*Assist. Surv. P.W.O. Ireland.*)

194. ABCD is a four-sided figure. For AB, BC, and CD, the azimuthal angles are  $40^\circ$ ,  $110^\circ$ , and  $225^\circ$ , and the lengths are 350, 420, and 390 links respectively. Plot the figure to a scale of  $\frac{1}{2}$  inch to a chain. Find the azimuthal angle and length of AD. Find the four included angles: reduce the figure to its equivalent triangle, and find its area in acres and decimals.

(*Roy. Agr. Coll. Cirencester.*)

195. From the point A on plan, lay off a portion of 160 acres, exclusive of road, and having a frontage of 2828 links.

(*Surv. Dept. Brisbane.*)

196. The sketch is a plan of an old survey, the posts and corner trees of which have disappeared, except those at A and F. It being necessary to establish the intermediate corners for road purposes, a traverse is run from A on the lengths and bearings of the plan; but in closing on to the corner F, the final bearing was found to be  $80^\circ 56'$ , and the length 1498 links instead of  $80^\circ$  and 1480 links. Find the difference between the old and the new chain, and modify the lengths and bearing in accordance, so that the positions of the old corners shall be obtained as nearly as possible.

(*Surv. Dept. Brisbane.*)

197. In reconnoitering in unmapped countries, it sometimes happens that the only available check upon your route survey is to find the latitude and longitude of your halting stations. Describe simple methods of ascertaining these points.

(*Civ. Eng. P.W.D. India.*)

198. A trial line bearing  $270^\circ$  is run 4192 links to pick up an old fenced line. In starting an offset of 5 links due south is taken, and on reaching the end of the line the offset is found to be  $4\frac{1}{2}$  links due north; using circular measure. Explain the principle of the method.

(*Surv. Dept. Brisbane.*)

199. Explain how in the field the time may be approximately ascertained by the prismatic compass.

(*Civ. Eng. P.W.D. India.*)

200. Find all boundaries and make the necessary computations for laying off from A towards B the portions A, B, C of 2 acres each, by lines parallel to A C.

(*Surv. Dept. Brisbane.*)

201. How would you plot long lines and angles without the aid of a protractor?

(*India Forest Service.*)

202. Explain the method of surveying with the plane table, describing the instrument employed and stating the circumstances which limit the accuracy of the method. *(Inst. C.E.)*

203. The vernier of a box sextant is set to 0. A vertical rod at a distance of about 500 feet is sighted. The portion of the rod seen through the clear glass and the portion reflected in the mirror appear in the same vertical line. Without altering the adjustment of the instrument a rod about 10 feet away is observed. The portion now seen in the mirror is no longer in the same vertical line with the portion seen through the clear glass. Explain this. *(Inst. C.E.)*

204. It is suspected that the horizontal circle of a theodolite is unequally divided. How would you test for this supposed error. *(Inst. C.E.)*

205. Sketch and explain the principles of either an Abney level, a Watkins clinometer, or any instrument of a similar type with which you may be familiar. *(Inst. C.E.)*

206. Sketch in detail any arrangement of levelling screws, such as are fitted to a level or a theodolite: one sketch should be a section through the vertical axis. *(Inst. C.E.)*

207. A dumpy level has accidentally fallen and been put out of adjustment. How would you proceed to put the instrument into working order? *(Inst. C.E.)*

208. In a transit theodolite, when the horizontal plates are exactly level, it is found that the horizontal axis of the telescope is not horizontal. Show how this error affects the horizontal angle subtended at the instrument by two observed points, and how the error due to the axis being out of the horizontal may be eliminated. *(Inst. C.E.)*

209. Describe with aid of sketches the theory and use of (a) the optical square, (b) the reflecting level, (c) the prismatic compass. *(Inst. C.E.)*

210. Explain the principle upon which the construction of a vernier is based. Why have some theodolites two sets of figures on the vertical arc verniers, while others have only one set? *(Inst. C.E.)*

211. What is the rate per chain (in feet and decimals) of a gradient rising 1 in 250? *(Surv. Inst.)*

212. A brick wall is laid in horizontal courses along a line ABC, from A to B the ground rises at angle  $10^\circ$ , from B to C it rises at  $22^\circ$ . Distance A to B is 230 feet, and B to C 150 feet. Give the number of steps required 1 foot in height between A and B and the number 2 feet in height between B and C. Also give the horizontal distance apart. *(Surv. Inst.)*

213. In a 5-inch theodolite reading to minutes a line on the vernier coincides with a line on the primary circle, what interval occurs between the next two lines which nearly coincide?

(*City Lond. Coll.*)

214. What arc does an angle of 1 minute subtend at a distance of 10 chains?

(*City Lond. Coll.*)

215. Explain the principle of the vernier, and in what manner would you construct a vernier to read 15 seconds when the arc is divided into quarter degrees.

(*Civ. Eng. P. W. D. India.*)

216. Give a sketch showing how you construct the divisions upon a vernier scale to a theodolite, the primary divisions of which read to degrees and thirds of a degree, in order to be able accurately to record angles to 30 seconds or half minutes by the aid of the vernier scale.

(*City Lond. Coll.*)

217. Give a sketch showing how you would construct the divisions upon a vernier scale to a theodolite, the primary divisions of which read to degrees and thirds of a degree, in order to be able accurately to record angles to 20 seconds or thirds of a minute by the aid of the vernier scale.

(*City Lond. Coll.*)

218. Give a sketch and description of a plain theodolite.

(*Val. Off. Ireland.*)

219. Describe how you make the adjustments of the line of collimations in the Y theodolite.

(*Roy. Agr. Coll. Cirencester.*)

220. In a transit instrument, explain the usual adjustments to test the accurate traverse of both the horizontal and vertical circles. Also describe the process of taking and booking an angle with the use of a theodolite set up over the intersection of two base lines.

(*City Lond. Coll.*)

221. Describe road traversing with the theodolite, what points should be especially attended to, and in what manner can the work be checked? What is the peculiar character of theodolite traversing, and why may this character not be equally maintained by using the magnetic meridian?

(*Civ. Eng. P. W. D. India.*)

222. What is a transit theodolite? Show the principal parts to a large scale, and describe these by reference letters.

(*Admiralty Assist. Civ. Eng.*)

223. Describe the operations of testing and setting up a theodolite, and all the uses to which this instrument can be put.

(*Admiralty Assist. Civ. Eng.*)

224. What are the various forms of theodolite? Make a detailed sketch of the simplest form.

(*Admiralty Assist. Civ. Eng.*)

225. Describe the method of adjusting the line of collimation of a level and theodolite, having two firm station points on level ground 7 chains apart.

(*Assist. Surv. P. W. O. Ireland.*)



226. State accurately the methods for adjustment for collimation in azimuth in a 5-inch transit theodolite; state your reasons for accepting one method before another. (*Surv. Dept. Brisbane.*)

227. On what scientific grounds would you condemn at once a theodolite or level, and state your methods of arriving at the conclusion. (*Surv. Dept. Brisbane.*)

228. How would you proceed to adjust a 5-inch transit theodolite? (*Inst. C.E.*)

229. How would you survey, with a theodolite and chain, the boundary of a thick wood through which it is impossible to range lines? In making a plan of the outline, how would you deal with errors of observation in angles and lengths? (*Inst. C.E.*)

230. Describe the theodolite and the successive operations necessary for the measurement of angles with it. (*Inst. C.E.*)

231. Give all the details of the methods you would adopt to run a straight line with an engineer's transit so as to eliminate experimental errors. (*Inst. C.E.*)

232. You have to make a plan of the boundary of a dense forest in a country where the compass is unreliable. How would you carry out the work? (*Inst. C.E.*)

233. What is a satellite station, and when is it used? How are observations from the satellite station reduced to the centre? (*Inst. C.E.*)

234. A base for a topographical survey is measured with a steel band. Explain the corrections applied to the field measurements in order to reduce the base for computation of the triangulation. (*Inst. C.E.*)

235. Explain how distances measured by triangulation are reduced to "mean sea-level." (*Inst. C.E.*)

236. How would you survey a town, and how would you commence to run the main lines in surveying a whole county? (*Val. Off. Ireland.*)

237. State under what circumstances you would employ the method, (a) of trigonometrical and (b) of chain surveying. (*Eastern Cadets.*)

238. Describe the method of measuring a base line by the aid of a chain and theodolite, pointing out the correction necessary for each angle of elevation or depression. (*Civ. Eng. P.W.D. India.*)

239. In a trigonometrical survey it is sometimes desirable to prolong a base line by triangulation. Explain the method of doing this, and illustrate it by a diagram. In a similar survey show by a diagram how the sides of the principal triangles may be increased as rapidly as possible from the measured base.

(*India Forest Service.*)

240. In the triangle ABC, given  $a = 1000$ ,  $B = 104^\circ$ , and  $C = 24^\circ 30'$ , find A and  $b$ . (*Roy. Agr. Coll. Cirencester.*)

241. Describe briefly the several steps taken in making a large trigonometrical survey, from and including the setting out and measuring up of the base lines to the filling in of the details. (*Eastern Cadets.*)

242. Construct a triangle ABC having its sides  $AB = 3$  inches,  $BC = 2\frac{1}{2}$  inches and  $AC = 1\frac{1}{2}$  inches. Suppose the points ABC to be trigonometrical stations of a survey, and that from a point D of a traverse A bears  $120^\circ$ , B  $150^\circ$ , and C  $165^\circ$ , find the point D by construction. (*Surv. Inst.*)

243. Where an object is selected as a trigonometrical point on which the theodolite cannot be set up, the angles taken from its vicinity require "reduction to the centre." Explain how this is done and illustrate it by a diagram. (*Civ. Eng. P. W. D. India.*)

244. How would you determine the latitude of any position (on land), and what instrument would you require? (*Surv. Inst.*)

245. How would you determine the height of a point on the opposite side of a river to yourself? An easily accessible point on the ground on your side is 150 feet above datum level; on it a level staff can conveniently be placed. The river is about 250 feet wide; the ground is fairly level, and there is no obstruction to the view. A chain and theodolite are to be used. (*Inst. C.E.*)

246. B is 1000 feet due east of point A. A theodolite is set up at A and B, and is at the same height in both cases. Point C when sighted from A has a whole circle bearing of  $100^\circ 6'$ , and an elevation of  $12^\circ 30'$ , and when sighted from B a whole circle bearing of  $105^\circ 18'$ . What is the height of point C above the theodolite? (*Inst. C.E.*)

247. Indicate the fundamental principles upon which surveying with the tacheometer is based, and explain briefly the method of applying tacheometry to the survey of rugged country. (*Inst. C.E.*)

248. A river has a width of 200 feet and an average depth of 7 feet. If the current is about 5 miles per hour, describe how you would proceed to determine the cross section as accurately as possible. (*Inst. C.E.*)

249. Explain how soundings are measured and located in making a hydrographical survey of a harbour. (*Inst. C.E.*)

250. Give three methods of finding the width of a river without using any instrument for measuring angles. The river is too wide to stretch a tape across. (*Inst. C.E.*)

251. A yachtsman measures the angle subtended by two lighthouses whose positions are shown on the chart. He then takes the

bearings of the two lighthouses. Show that the second observation is sufficient to fix his position, while the first observation is not.

(*Inst. C.E.*)

252. Describe the principal parts of the sextant, and explain by diagrams how you would use it in locating soundings. (*Inst. C.E.*)

253. Describe the method of setting out curves with and without a theodolite. (*Eastern Cadets.*)

254. Explain fully the method of setting out a curve of given radius with a theodolite. (*Eastern Cadets.*)

255. Make a figured sketch and show your calculations for joining two lines with a curve half a mile radius, the included angle between the lines being 120 degrees. (*Eastern Cadets.*)

256. Marking out a canal in a given direction, AB, you find that the alignment, if prolonged, would take you through a village; to avoid this you change the direction to a line, BC, and between the points A and C you trace a curve with a radius of 4 miles. Describe the method of doing this in the field and, without going through the necessary calculations in detail, explain how they are made, when required, the distances AB and BC being measured and the angle ABC observed. (*Civ. Eng. P.W.D. India.*)

257. The following bearings and distances were taken along a centre line of a road survey:

AB bearing 15 degrees, distance 1200 feet.

BC " 45 " " 1000 "

CD " 310 " " 1400 "

Connect AB and CD by an S curve from B to C, the two portions having equal radii. (*Civ. Eng. P.W.D. India.*)

258. Explain the construction and formulas for the calculation of cuttings and embankments, and how and when to use them.

(*Mason Coll. B'ham.*)

259. What are the chief things to aim at as regards cuttings and embankments? What is the quantity it is best to try to reduce to a minimum? (*Mason Coll. B'ham.*)

260. What would be the cost of a cutting 33 feet wide at the formation level, with slopes  $1\frac{1}{2}$  to 1 and depths 0, 9, 24, 15, 0 feet taken at 1 chain distances, the price of excavation being 3s. per cubic yard? (*Mason Coll. B'ham.*)

261. A cutting is to be made through the solid rock for a straight road 350 feet long. The depths in feet at 50 feet apart are 0, 5, 7, 10, 13, 9, 6, 0; the width of the road 15 feet and the slopes  $\frac{1}{2}$  to 1. Calculate the contents of the cutting. (*India Forest Service.*)

262. A straight level road runs east and west; the summit of a hill observed from a point in the road, due north, at an angular elevation of 32 degrees, from another point a quarter of a mile

along the road the elevation is found to be 19 degrees. Find the height of the summit above the road in feet.

(*Admiralty Assist. Surv.*)

263. The sides of a triangle are 2040, 5095, and 5960 links. Find (1) the angles, (2) the area.

(*Surv. Dept. Brisbane.*)

264. The telescope of a theodolite is set 4.25 feet above the point A having a level value of 25 feet, is directed towards the bottom of a staff at B and shows an angle of elevation of  $10^{\circ} 4'$ , it is then directed to 10 feet on the staff, when it shows an angle of elevation of  $10^{\circ} 35'$ . Required the horizontal distance A to B in feet and also the level of the point B.

(*Surv. Inst.*)

265. The point A being inaccessible and at a considerable altitude above the surrounding country, illustrate and describe in what way you would ascertain its height above the point B (the nearest convenient point of observation) using a theodolite for the purpose.

(*Surv. Inst.*)

266. What are the simplest methods of surveying in a town and in the country? Describe each method and any desirable method of checking these surveys.

(*Admiralty Assist. Civ. Eng.*)

267. Describe and prove any method of obtaining the distance between two marked points on the opposite sides of the river without the use of angle measuring instruments. How would you make this measurement if you had a theodolite or sextant at your disposal.

(*Univ. Coll. London.*)

268. Describe the process of setting up a theodolite at the first two stations of a survey. Show that by the method employed, the telescope will always point to the north if, at any station whatever, the instrument be put to zero.

(*Univ. Coll. London.*)

269. What are the objects and advantages of the method of plotting by "traversing"? What essential condition must be fulfilled by any instrument in order that its results may be used in this way?

(*Univ. Coll. London.*)

270. Describe briefly the system used in carrying out the Ordnance Survey of this country.

(*Univ. Coll. London.*)

271. Describe the information that has to be obtained, and the surveys with sketches, which have to be made for locating a railway through a mountainous district.

(*Inst. C.E.*)

272. The formation level of a railway embankment is 30 feet wide, the side slopes are  $1\frac{1}{2}$  horizontal to 1 vertical, and the height of the centre 8.8 feet above the original surface of the ground, which has a slope of 5 horizontal to 1 vertical in a direction at right angles to the line of the railway. Find the area of the cross section of the embankment.

(*Inst. C.E.*)

273. Explain the principle upon which the setting out of railway curves with a theodolite is based, and find a general formula for the tangential angle suitable for any radius and any length of chord. *(Inst. C.E.)*

274. Two straight lines meeting at a known angle are to be joined by a  $2^\circ$  curve. Describe the computations required and the method of lining out the curve in 100-foot lengths. *(Inst. C.E.)*

275. Two converging lines of railway which would if produced meet at an angle of  $140^\circ$  are to be joined by a curve of 20 chains radius. What would be the distance from the intersection to the starting point of the curve, and the length of the curve in chains? How would you set out this curve in practice? *(Inst. C.E.)*

276. Describe the setting out of a double junction, the main lines being straight and the radius of the branch line 15 chains; length of stock-rail 18 feet. Give the distance of each crossing from the point of the switch and the spread of each crossing. *(Inst. C.E.)*

277. The tangents to a curve meet at an angle of  $150^\circ$ . On the bisector of this angle is a point 53 feet from the vertex through which the curve must pass. Find the radius of the required curve and the tangent distance. *(Inst. C.E.)*

278. In lining out a curve for the centre line of a railway, what are the practical advantages in using a curve of  $x^\circ$  curvature rather than a curve of  $y$  feet radius? What is the fundamental formula connecting the radius of a curve and its tangential angle? *(Inst. C.E.)*

279. A pipe line has been laid on a curve of unknown radius joining two straight lengths. It is found that the tangents measure 83.2 feet, and that the contained angle is  $156^\circ 30'$ . Find the length and radius of the curve, also the chord and the distance of the centre of the curve from the point of intersection. *(Eng. N.S.W.)*

280. The pipe line as above has been marked at every 50 feet to the commencement of the curve, which is found to start at 784.6 feet on the continuous chainage. It is desired to carry on this chainage round the curve, fixing the points with a theodolite by tangential angles. Calculate and tabulate the tangential bearings to be set off on the instrument, and fully describe how you would carry out the marking, and check the close of both bearings and chainage—(a) If all the points can be observed from the tangent points, (b) if the two tangent points cannot be seen from one another. *(Eng. N.S.W.)*

281. In case (a), how could the curve be marked without chaining the chords? Describe the process. *(Eng. N.S.W.)*

282. The following staff readings have been taken with a dumpy level: Back sight 13.06 feet at 700 feet. Intermediate sight

10.43 feet at 800 feet. Intermediate sight 6.86 feet at 900 feet. Fore sight 1.22 feet at 1,000 feet. Back sight 12.74 feet at 1,000 feet. Intermediate sight 8.31 feet at 1,100 feet. Fore sight 2.16 feet at 1,200 feet. The reduced level at the starting point is 100 feet above datum. Rule off the proper columns for booking these readings, enter the readings, compute the reduced level at each station, make the ordinary test checks of the calculations, and give the gradient between the extreme points. (*Eng. N.S.W.*)

283. Give the method of testing and correcting a theodolite—(a) for error in collimation in azimuth, (b) for error in collimation in altitude. (*Eng. N.S.W.*)

284. State the methods you would adopt, apart from adjusting your theodolite, to eliminate slight errors in adjustment—(a) in running a straight line, (b) in observing horizontal angles. State what errors are eliminated by the process you adopt. (*Eng. N.S.W.*)

285. Describe fully the adjustment of the dumpy level for parallax and collimation, and state what methods you would adopt in observations to eliminate all probable errors in adjustment. (*Eng. N.S.W.*)

286. In a triangle, ABC, the length of AB is 55 feet, of AC 70 feet, and angle A is  $53^{\circ} 22'$ . Find side BC and angles B and C, and compute the area of the triangle in square feet and in acres. (*Eng. N.S.W.*)

287. In a circle of 40 feet diameter a segment has a chord of 28 feet: find (a) the versed sine of the segment, (b) the distance from the centre of an ordinate 5 feet long, (c) the area of the segment in square feet. (*Eng. N.S.W.*)

288. Sketch half-a-dozen adjacent fields, and illustrate by ruled lines the method of surveying them with the chain only. (*Admiralty Assist. Surv.*)

289. Make a sketch of an irregular plot of land and describe how you would obtain the area. Chain lines are to be shown upon the paper. (*Inst. San. Eng.*)

290. Show by sketch how you would lay out the survey lines on a nearly regular five-sided field. Assuming your sketch to be to scale of 3 chains to 1 inch, give the approximate area in acres, roods, and perches. (*Inst. San. Eng.*)

291. In taking particulars for laying a sewer it was found that it was impossible to see from end to end of the proposed route owing to the centre of the land being higher. Illustrate by sketch how you would obtain a straight line. (*Inst. San. Eng.*)

292. Give the levels of points B, C, and D on a continuous

section, the level of point A being 25 feet, and the horizontal distances and angles as follows :—

A to B, 12 chains ; angle of elevation,  $3^{\circ} 20'$ .

B to C, 9 " " depression,  $4^{\circ} 25'$ .

C to D, 15 " " elevation,  $2^{\circ} 15'$ .

(*Surv. Inst.*)

293. Construct a triangle ABC, having its sides  $AB = 3$  inches,  $BC = 2\frac{1}{2}$  inches, and  $AC = 1\frac{1}{2}$  inches. Suppose the points A, B, and C to be trigonometrical stations of a survey, and that from a point D of a traverse A bears  $120^{\circ}$ , B  $150^{\circ}$ , and C  $165^{\circ}$ , find the point D by construction.

(*Surv. Inst.*)

294. It is proposed to fence round a piece of open ground and to convert it into a recreation ground. Pegs have been driven in at the five corners A, B, C, D, and E. The relative positions of the pegs were found to be as follows : B is south-east of A, C is south-south-west of B, and D is due west of C ; angles  $BAC 28^{\circ} 30'$ ,  $CAD 35^{\circ}$ ,  $DAE 36^{\circ}$ ,  $AED 95^{\circ}$  ; and the distance between pegs A and B 10.40 chains. Make a plan of the piece of ground, state the length of fencing required to enclose it, and find the area.

(*Admiralty Assist. Surv.*)

295. With the aid of sketches, describe the construction and method of use of *one* of the following instruments : (1) prismatic compass, (2) optical square, (3) box sextant.

(*Admiralty Assist. Surv.*)

296. In the construction of a railway tunnel, what methods should be adopted for determining the alignment above and below ground ?

(*Admiralty Assist. Surv.*)

297. What errors in direction are likely to arise in surveys made with the magnetic needle, and how can such errors be controlled and corrected ?

(*Admiralty Assist. Surv.*)

298. Describe the process of setting out a large rectangular building, by means of the theodolite. Illustrate your answer by sketches.

(*Inst. San. Eng.*)

299. Show by the aid of a sketch diagram, accompanied by a brief description, in what way you would proceed to take and fix a series of soundings from the shore to a distance of half-a-mile from land, describing the instruments you would use, and the appliances, fixed marks and assistants you would deem essential.

(*City Lond. Coll.*)

300. How would you obtain a cross section of a river when there is neither a boat nor a raft available ?

(*Mun. & County Eng.*)

## INDEX

### A

- Abney's reflecting level, 77.
- Acres, roods and perches, 6, 12.
- Adjustment for collimation, 128.
  - for parallax, 127.
- Allowance for slope of ground, 75.
  - for width of ditch, 35.
- Alphabet, Morse, 242.
- Amsler's planimeter, 44.
- Aneroid barometer, 150, 154.
- Angle, Definition of an, 156.
- Angle of slope, Measuring the, 76.
- Angles on chain line, 173.
- Angular measurement, 156.
- Annual variation of the compass, 18.
- Area by equalising lines, 42.
  - by computing scale, 43.
  - by planimeter, 44.
  - of rectangle, 8.
  - of triangle, 9.
- Areas of regular figures, 8.
- Arrangement of chain lines, 48.
- Astronomical surveying, 235.

### B

- Backbone of survey, 49.
- Back sights and fore sights, 134.
- Barometer, Aneroid, 150.
  - Levelling with, 150.
  - Mercurial, 150.
- Base line of survey, 15.
  - Ordnance Survey, 179.
- Batters and slopes, 204.
- Bearing of a line, 10.
- Bench Marks, 133.
- Boundaries, Nature of, 33.
- Boundary, Owner's side of, 35.

- Box sextant, 165.
  - vernier, 164.
  - tape, 21.
- Brace, Use of, 35.
- British standard of length, 7.
- Brook Meadow, Survey of, 50.
- Bubble error, 129.
- Builders' dumpy, 120.
- Building plots, Surveying, 150.
- Bull-headed rail, 222.

### C

- Casting by equalising lines, 42.
- Celestial sphere, 235.
- Centrifugal force, 221, 225.
- Cess, Allowance for, 206.
- Chain and arrows, 23.
  - lines, how marked, 27.
  - mode of using, 24.
  - scales, 13.
  - traversing, 96.
- Chaining across a gravel pit, 67.
  - river, 66, 67.
  - round a bend, 63.
  - building, 65.
  - Signals in, 23.
- Charge for surveys, 94.
- Charlie's wain, 235.
- Check levels, 133.
  - lines, 21.
- Chesterman's metallic tape, 22, 193.
- Chords, Scale of, 158.
- Circumferenter, 100.
- Closed traverse, 105, 109.
- Collimation, 127.
  - system of booking levels, 144.
- Colouring plans, 53.



- Compass, Pocket, 15.  
 surveys, Use of, 100.  
 traversing, 98.
- Compound curves, 209, 214, 223.  
 levelling, 126.
- Computing scales, 43.
- Constellations, 102.
- Contouring building plots, 150,  
 153.  
 Methods of, 79.
- Contour lines, 78.
- Conventional signs, 27.
- Copyhold, Enclosure and Tithe  
 Commission, 90.
- Copying plans, 111.
- Cost of surveys, 94.
- Correction for curvature and re-  
 fraction, 124.
- Cross sections, 139.  
 staff, 55, 60.
- Curvature, 123.
- Curve by one theodolite, 230.  
 by two theodolites, 231.  
 elements, 209.  
 formula, 209.  
 To find radius of, 229.  
 ranging, 227.  
 tangents, 210.
- Curves by oblique offsets, 228.  
 on bridges, 229.  
 by rectangular offsets, 228.  
 Railway, 207.
- Crossing, Railway, 233.
- Cross-over roads, 233.
- Culmination, 236.
- Cutting up a plan, 48.

## D

- Daily variation of compass, 17.
- Datum line, 136.
- Declination, 236.
- Definition, axiom and postulate, 2.
- Degree curves, 207.
- Degrees and grades, 157.
- Departure or longitude, 101, 103.
- Detours and gaps, 63.
- Diagonal scales, 162.
- Difference of latitude, 102.  
 longitude, 103.
- Ditch and hedge, 33.

P.S.

- Dot or spot levels, 150.
- Double chain lines, 193.
- Drawing field outlines, 32.  
 to scale, 13.
- Dumpy levels, 118.

## E

- Earthwork terms, 204.
- Eidograph, 114.
- Engineering field work, 202.
- Enlargement and reduction of  
 plans, 112.
- Entries in field book, 24.
- Equalising lines, 42.
- Equation of time, 238.
- Errors in chaining, 94.  
 levelling, 131.  
 scaling, 117.
- Everest Theodolite, 170.

## F

- Facing points, 233.
- False stations, 49.
- Fences, 35.
- Field book, Entries in, 24.  
 columns, 136.
- Finished plans, 53.
- First-class plans, 90.
- Flag signalling, 242.
- Flying levels, 133.
- Focussing a level, 130.
- Fore sights, 134.
- Formation breadth, 204, 206.
- Forward and reverse bearings, 99,  
 101.
- Fractions of perch, how dealt with,  
 12.

## G

- Gaps and detours, 63.
- Geographical north, 16.
- Geometry, Definition of, 1.
- Give-and-take lines, 42.
- Goliath rail, 222.
- Grades and degrees, 157.
- Græm's Dyke, 34.
- Gravatt's dumpy level, 118.
- Great triangulation, 179.
- Gunter's chain, 22.  
 mode of using, 23.

S

## H

- Hachures, 78.  
 Hand reflecting level, 79.  
 Hedge and ditch, 33.  
 Hedges and trees on plans, 41.  
 Heights, Measurement of, 181.  
 Heliographing, 243.  
 Hill shading, 78.  
 Hilly ground, Corrections for, 74.  
   how indicated, 78.  
   Poling over, 39.  
 Holding the staff, 131.

## I

- Inclination, Corrections for, 74.  
 "Instruction to surveyors," 90.  
 Intermediates, 136.  
 Inverted curve, 209.

## J

- Jacob staff, 99.

## L

- Lake, Survey of a, 57.  
 Land-breadth, 204.  
   surveying, Scope of, 1.  
 Latitude, Difference of, 101.  
   Finding the, 239.  
 Level and horizontal lines, 122.  
   book, Keeping the, 144.  
   pegs, 203.  
   staff, 121.  
 Levelling, Definition of, 118.  
   Errors in, 131.  
   with barometer, 150.  
 Levels of building plots, 148.  
 Limit of accuracy in plotting, 192.  
 Linear measure, Table of, 5.  
   measurement, 7.  
 Link, Length of a, 7.  
 Location field book, 202.  
 Long chain line, 88.  
 Longitude and local mean time,  
   237.

## M

- Magnetic meridian, 16.  
 Main sections. 141.

- Map scales, 116.  
 Marks on plans, 35.  
 Mean solar day, 238.  
 Measurement of straight-lined  
   figures, 20, 26.  
 Measuring across a river, 66.  
   offsets, 28.  
 Mercator's projection, 71.  
 Meridian distance, 101, 103.  
   lines, 101.  
   Magnetic, 16.  
   To determine the, 235.  
 Miner's dial, 100.  
 Minimum radius of curves, 209.  
 Minus readings, 138.  
 Monthly variation of compass, 17.  
 Morse code, 242.

## N

- Nadir, 236.  
 Nomenclature of curves, 208.  
 Northing and southing, 101.  
 North point by watch, 16.  
   on plan, 19.

## O

- Obstruction by rising ground, 38.  
 Obstructions, Measuring past, 55.  
 Office columns, 136.  
   plans, 53.  
   work in surveying, 1.  
 Offset piece, 30.  
   scale, 31.  
 Offsets, 26.  
 Open and closed traverses, 105,  
   107; 109.  
 Optical square, 58, 60.  
 Ordnance bench mark, 137.  
   datum, 134.  
   map scales, 116.  
   survey, 179.  
 Owner's side of boundary, 35.

## P

- Pantagraph, 114.  
 Parallax, 127.  
 Parish boundaries, 33.  
   plans, 90.

Parliamentary plans, 94.  
 Party wall, 33.  
 Perch, Fractions of, 12.  
 Permanent stakes, 203.  
 Perpendiculars, To set up, 61.  
 Plane table, 167.  
 Planimeter, Use of, 44.  
 Platelayers' curves, 227.  
 Plotting, 13.  
   columns, 136.  
   from field notes, 31.  
   sections, 136.  
   traverse surveys, 107.  
 Pointers, 102.  
 Points or switches, 232.  
 Pocket compass, 15.  
 Polar projection, 71.  
 Pole Star, 102, 235, 236.  
 Poling over hilly ground, 38, 39.  
 Practical curve ranging, 231.  
   geometry, Exercises in, 2.  
 Pricking through, 112.  
 Primary circle, 170.  
 Prime vertical, 237.  
 Prismatic compass, 97.  
 Projection, Various systems of, 71.  
 Proportional compasses, 114.  
   squares, 112.  
 Protractor and plummet, 76.  
 Protractors, 158.  
 Pure and applied geometry con-  
   trasted, 2.

## Q

Quarry, Chaining across a, 67.

## R

R.A. (Right ascension), 238.  
 Radial measurement of angles, 157.  
 Railway chair, 221.  
   crossing, 233.  
   curves, 207.  
   gauges, 202.  
   surveying, 201.  
 Rails, Length of, 220.  
 Ranging a curve, 227.  
 Rectangle, Area of, 8.  
 Reduced level, 135.

Reducing the bearings, 99.  
   levels, 135.  
 Reduction of closed traverse, 110.  
   open traverse, 108.  
   to single meridian, 105.  
 Reference book, 201.  
 Refraction, 123.  
 Regulations for testing plans, 93.  
 Repeating an angle, 174.  
 Reverse bearing, 101.  
   curve, 209, 217, 218.  
 Right ascension, 238.  
 Rise and fall system of booking  
   levels, 144.  
 Roman wall and ditch, 34.  
 Routine of a survey, 49.  
 Running levels, 133.

## S

S curve, 209.  
 Scale of chords, 158.  
 Scales for maps, 116.  
 Setting out foundations, 204.  
 Setting up a level, 129.  
 Sextant, Box, 165.  
   Nautical, 241.  
 Shrinkage of tape, 193.  
 Side width, 204.  
 Sidings from main line, 233.  
 Sight vanes, 100.  
 Signalling, 242.  
 Simple curve, 208.  
 Simpson's rule, 44.  
 Sines and cosines, 105.  
 Skeleton town survey, 187.  
 Slopes and batters, 204.  
 Sloping ground, Chaining on, 74.  
 Sopwith level-staff, 121.  
 Split vernier in Abney level, 77.  
 Spoil bank, 141.  
 Spot levels, 150.  
 Square measure, Explanation of, 7.  
   Table of, 6.  
 Stadia points, 196.  
 Staff, Holding the, 131.  
 Standard of length, 7.  
 Station poles or pickets, 26.  
 Steel tape, 24.  
 Stepping with a chain, 75.  
 Super-elevation of outer rail, 221.

Survey, Base line of, 15.  
 of small farm, 82.  
 of woods and lakes, 55.  
 Surveying by the back angle, 177.  
 from two stations, 179.  
 Surveyor's card, 76.  
 compass, 100.  
 Switches, 232.  
 Systems of surveying, 5.

## T

T, Meaning of, 35.  
 Tallies on chain, 24.  
 Tangential projection, 73.  
 Tape measurement, 21.  
 Shrinkage of, 22  
 survey, 198.  
 Telemetry, 145.  
 Telepost alphabet, 242.  
 Testing plans, 93.  
 Theodolite, Adjustment of, 171.  
 angles on chain line, 173.  
 Construction of, 170.  
 Methods of using the, 176.  
 traverse, 177.  
 vernier, 163.  
 Three-point problem, 168.  
 Tie and check lines, 21.  
 lines in traversing, 96.  
 Time, Astronomical, 238.  
 Divisions of, 238.  
 Greenwich mean, 238.  
 Local mean, 237.  
 Sidereal, 238.  
 Town planning, 184.  
 surveying, 184, 194.  
 Tracing, 111.  
 Transit theodolite, 170, 172.

Transition curves, 214, 223, 225.  
 Trapezium, Area of, 10.  
 Traverse tables, 106.  
 Traversing with chain, 96.  
 with prismatic compass, 98.  
 Terms used in, 101.  
 Trees on plans, 41.  
 Triangle, Area of, 9.  
 Triangular compasses, 112.  
 Triangulated offsets, 188.  
 Tribach level, 130.  
 Trigonometry, Principle of, 156.  
 Trinity high-water mark, 134.  
 True north, 16.  
 Turnout, Railway, 232.

## U

Unit of measurement, 7.  
 Universal chain scale, 14.

## V

Variation of the compass, 17.  
 Vernier scales, 163.  
 Vertical circle, 170.

## W

Watch, North point by, 16.  
 Whites, 51.  
 Widening of gauge on curves, 223.  
 Wires in levels and theodolites,  
 128, 146.  
 Wood, Survey of a, 56.  
 Working section, 141.

## Z

Zenith, 236.

*WORKS BY THE SAME AUTHOR.*

---

- \***JOINTS IN WOODWORK.** Demy 8vo. 44 pp., with large plate of 80 joints. 6d. net, postage 1d.
- \***TIMBER PILING, IN FOUNDATIONS AND OTHER WORKS.** Demy 8vo. 24 pp., with folded plate. 6d. net, postage 1d.
- STRAINS IN IRONWORK.** Crown 8vo, cloth, with 8 folded plates, containing 172 illustrations. 5s. post free. (Spon.)
- \***DESIGNING IRONWORK (Second Series):**
- Part 1. Steel Box Girders. 26 pp., and folded plate. 9d. net, postage 1d.
  - Part 2. Built-up Steel Stanchions. 59 pp., and 2 folded plates. 1s. 3d. net, postage 1½d.
  - Part 3. Cisterns and Tanks. 48 pp., and 2 folded plates. 1s. net, postage 1d.
  - Part 4. Rolled Joists, Compound Girders and Fire-resisting Floor. 52 pp., and folded plate. 1s. net, postage 1½d.
- PRACTICAL TRIGONOMETRY FOR ENGINEERS, ARCHITECTS AND SURVEYORS.** Crown 8vo. 69 pp., illustrated. 2s. 6d. net, postage 3d. (Whittaker.)
- ENGINEERS' HANDBOOK.** Royal 8vo. 576 pp. 7s. 6d. net, postage 6d. (Cassell.)
- CASSELL'S BUILDING CONSTRUCTION.** Royal 8vo. 568 pp. 2284 illustrations and 12 coloured plates. 7s. 6d. net, postage 6d. (Cassell.)
- \***EXAMINATION WORK IN BUILDING CONSTRUCTION.** Demy 4to. 56 pp., including 23 full page plates. 2s. 6d. net, postage 3d.
- REINFORCED CONCRETE: IN THEORY AND PRACTICE.** Demy 8vo. 316 pp., with 324 illustrations. 10s. 6d. net, postage 6d. (Longmans.)
- THE MECHANICS OF BUILDING CONSTRUCTION.** Demy 8vo. 240 pp., with 589 illustrations. 6s. net, postage 4d. (Longmans.)
- THEORY AND PRACTICE IN DESIGNING.** Demy 8vo. 240 pp., with 370 illustrations. 6s. net, postage 4d. (Constable.)
- 

**From all Booksellers, or (\*) direct from the Author,  
60 Queen Victoria Street, London, E.C.**



## Works on Engineering.

---

- Field and Colliery Surveying. A Primer designed for the use of Students of Surveying and Colliery Manager Aspirants. By T. A. O'DONAHUE. Globe 8vo. 3s. 6d.
- Lessons in Applied Mechanics. By J. H. COTTERILL, F.R.S., and J. H. SLADE. Fcap. 8vo. 5s. 6d.
- Applied Mechanics for Beginners. By J. DUNCAN. Globe 8vo. 2s. 6d.
- Steam and other Engines. By J. DUNCAN. Globe 8vo. 5s.
- The Steam Engine, and Gas and Oil Engines. By Prof. JOHN PERRY, F.R.S. 8vo. 7s. 6d. net.
- Marine Engineering. By Engineer-Commander A. E. TOMPKINS, R.N. 8vo. 15s. net.
- The Mechanics of Machinery. By Sir Alex. B. W. KENNEDY, F.R.S. Crown 8vo. 8s. 6d.
- Simple Practical Methods of Calculating Strains on Girders, Arches, and Trusses. With a Supplementary Essay on Economy in Suspended Bridges. By E. W. YOUNG. 8vo. 7s. 6d.
- Building Construction for Beginners. By J. W. RILEY. Globe 8vo. 2s. 6d.
- Graphical Methods in Applied Mathematics. By G. C. TURNER, B.Sc. Crown 8vo. 6s.

LONDON : MACMILLAN AND CO., LTD.

## Works on Practical Mathematics.

---

Elementary Practical Mathematics. By Prof.  
JOHN PERRY, D.Sc., F.R.S. 8vo. 6s.

Calculus Made Easy. By F.R.S. Globe 8vo.  
2s. net.

Practical Integration for the Use of Engineers,  
etc. A. S. PERCIVAL, M.A. Crown 8vo. 2s. 6d. net.

Four-Figure Mathematical Tables. Comprising  
Logarithmic and Trigonometrical Tables, and Tables of  
Squares, Square Roots, and Reciprocals. By J. T. BOTTOMLEY,  
M.A. 8vo. 2s. 6d.

A First Book of Practical Mathematics. By T.  
S. USHERWOOD, B.Sc., and C. J. A. TRIMBLE, B.A. Globe 8vo.  
1s. 6d.

*By F. CASTLE, M.I.M.E.*

Practical Mathematics for Beginners. Globe 8vo.  
2s. 6d. Key, 5s. net.

Elementary Practical Mathematics for Technical  
Students. Globe 8vo. 3s. 6d.

A Manual of Practical Mathematics. Globe 8vo.  
6s.

Practical Arithmetic and Mensuration. Globe  
8vo. 2s.

Workshop Mathematics. In two parts. Globe  
8vo. 1s. 6d. each.

Logarithmic and other Tables for Schools. 8vo.  
8d. Sewed. 6d.

Five-Figure Logarithmic and other Tables.  
Fcap. 4to. 1s.

LONDON: MACMILLAN AND CO., LTD.





RETURN TO the circulation desk of any  
University of California Library  
or to the  
NORTHERN REGIONAL LIBRARY FACILITY  
Bldg. 400, Richmond Field Station  
University of California  
Richmond, CA 94804-4698

---

ALL BOOKS MAY BE RECALLED AFTER 7 DAYS

- 2-month loans may be renewed by calling  
(510) 642-6753
  - 1-year loans may be recharged by bringing  
books to NRLF
  - Renewals and recharges may be made 4  
days prior to due date.
- 

DUE AS STAMPED BELOW

---

**FEB 18 1999**

---

---

---

---

---

---

---

---

---

---

---

---

12.000 (11/95)

---

ID 11007

copy  
pre use  
son

U. C. BERKELEY LIBRARIES



C042159410

TA 545  
A2

290923

Adams

UNIVERSITY OF CALIFORNIA LIBRARY



