

Class TS 230

Book T 23

Copyright N^o _____

COPYRIGHT DEPOSIT.



FOUNDRY PRACTICE

A TREATISE ON
MOLDING AND CASTING
IN THEIR VARIOUS DETAILS

BY
JAMES M. TATE
AND
MELVIN O. STONE, M.E.

PREPARED FOR THE USE OF STUDENTS IN THE COLLEGE OF
ENGINEERING, UNIVERSITY OF MINNESOTA

THIRD EDITION, REVISED

NEW YORK
JOHN WILEY & SONS
LONDON: CHAPMAN & HALL, LIMITED
1909

T 5230
T 23

LIBRARY of CONGRESS
Two Copies Received
JAN 12 1909
Copyright entry
Jan. 6, 1909
CLASS 2 XXc. No.
227174
COPY 3.

Copyright, 1904, 1909
BY
JAMES M. TATE

9-15991



The Scientific Press
Robert Drummond and Company
New York

INTRODUCTION

IN administering the work in foundry practice at the University of Minnesota, the want of a good text-book has been a serious disadvantage. The work of the shop and that of the class-room should be correlated—shop-work should be studied and discussed in the class-room, and examples illustrating the various principles underlying good practice should be worked out in the shop.

While there have been some excellent books written upon the subject of foundry practice, yet, as a rule, these have been written with the needs of the experienced molder in view rather than those of the beginner. For this reason it is a difficult matter to teach the subject so that the student will acquire an intelligent understanding of its various details. The nomenclature and shop phraseology are not sufficiently elementary for the average beginner to grasp the statement presented, and much time is frequently spent in explaining an author's meaning.

The present little treatise has been written with a full knowledge of the problems involved and with the object of lessening some of the difficulties which arise in teaching the subject. The authors are both men of wide experience in foundry practice and its correlated subjects. Mr. Tate is an experienced pattern maker, who has been in charge of the pattern shop at the University of Minnesota for the past fifteen years, and during a part of this time he has also had charge of the work in the foundry. Mr. Stone is a graduate of the University,

who has given especial attention to foundry work, both from the standpoint of the chemist and from that of the molder.

In presenting this work on foundry practice, the authors realize that it is not a complete treatise on the subject. The aim has been to produce a book in which the principles of foundry practice are set forth concisely and clearly. The needs of the engineering student rather than those of the practical foundryman were kept in view. To this end numerous examples are given representative of the different kinds of molding, and it is believed that the simple methods used in illustrating and describing the various operations involved and the reasons therefor will give the student a ready knowledge of the details of molding which will go far to supplement the practical work of the foundry, which, in a college course, must necessarily be limited.

While the treatment is thus somewhat brief, the subject matter as here presented is intended to cover all ordinary work in foundry practice, including both brass and iron casting.

A glossary of foundry terms has been added, as it has been found that to obtain the greatest value from a work of this character the reader must become familiar with names and expressions used by foundrymen, for even if it were possible to eliminate shop expressions, it would be undesirable to do so.

J. J. FLATHER,

Professor of Mechanical Engineering,
UNIVERSITY OF MINNESOTA

MINNEAPOLIS, MINNESOTA,
September, 1904.

CONTENTS

CHAPTER I

	PAGE
GREEN SAND MOLDING	I
Plain mold. Parted pattern. Coping out. Bedding in. Setting cores. Check molding.	

CHAPTER II

DRY SAND MOLDING	53
Dry sand mixtures. Venting. Drying, finishing, blacking. Skin-drying, pit mold, and sweeps.	

CHAPTER III

MOLDING SAND, MOLDER'S TOOLS, MOLDING MACHINES, AND EQUIPMENT	69
Facing sand. Flasks. Gating. Gaggers. Soldiers. Nails and rods. Patching. Stopping off. Venting cores. Chaplets. Setting chaplets. Weighting and clamping. Shrink holes. Burning on, or casting on. Bench molding. Snap-flasks. A match. Molding machines.	

CHAPTER IV

CORES, CORE BOXES, CORE MACHINES, AND DRYING OVENS.....	123
---	-----

CHAPTER V

CUPOLAS, BLOWERS, AND MELTING FURNACES FOR IRON	151
Tapping hole. Tuyères. Charging door, hearth. Slag notch, lining, charging, tapping out. Ladles, blowers.	

CHAPTER VI

	PAGE
CHILLED CASTINGS	172
The chill. Mixture of iron for chilled casting.	

CHAPTER VII

MALLEABLE CASTINGS	176
The malleablizing process.	

CHAPTER VIII

CLEANING CASTINGS	180
Hand work. Tumbling barrels, rattlers. Sand blast, pneumatic hammers, portable grinders.	

CHAPTER IX

COMPRESSED AIR FOR FOUNDRY PURPOSES	185
Pneumatic crane. Hoist. Molding machine, chipping hammer. Sand rammer. Sifter.	

CHAPTER X

STEEL CASTINGS	195
The sand mixture. The mold. The mixtures of metal. Melting and converting.	

CHAPTER XI

BRASS FOUNDRY	199
Brass molding. The sand. The flask. The furnace. Oil furnaces.	

CHAPTER XII

CAST-IRON ALLOYS	208
Tables for foundry use.	

CHAPTER XIII

GLOSSARY OF FOUNDRY TERMS	215
---------------------------------	-----

FOUNDRY PRACTICE

CHAPTER I

GREEN SAND MOLDING

THE method of proceeding in making a mold for a **plain casting** may be demonstrated by consideration of the pattern shown in Fig. 1. After having the sand

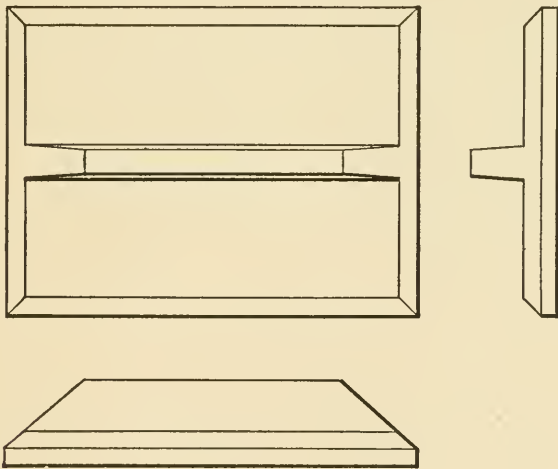

FIG. 1.

properly tempered, the turn-over board is placed on a sand bed so as to have bearing all over to avoid rocking or unevenness of the top. The pattern is then placed

on the board as shown in Fig. 2. The drag may now be placed over the pattern and facing sand riddled onto the



FIG. 2.

pattern. Cover the pattern with sand to a depth of approximately 6 inches, as shown in Fig. 3. The sand is rammed around the edge of the flask with the pein rammer by directing it as shown at A, Fig. 3. It is next rammed around the pattern with the rammer directed as shown at B, Fig. 3. The sand falling between these two rammings

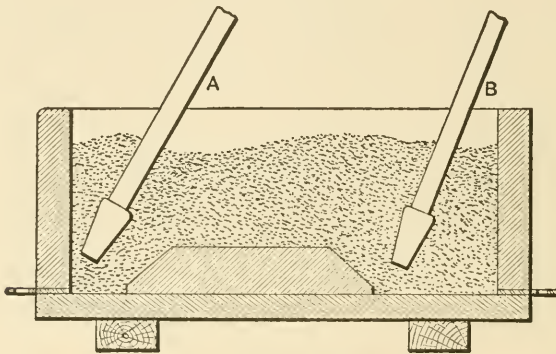

FIG. 3.

is then rammed to an even hardness sufficient to form a firm body and allow the free escape of the gases.

Care should be taken in ramming to avoid striking the rammer nearer to the pattern than one inch. Wherever the pein strikes the pattern, a hard spot is left in the sand which will cause a scab on the casting. The flask is now filled full of heap sand and rammed with the butt

rammer, as shown in Fig. 4. The drag may now be struck off with a straight edge even with its top. A thin layer of loose sand is then scattered over the surface to ensure a good bearing on the entire surface of the bottom board. The drag should now be vented with one-eighth inch wire all around and over the pattern, using care not to strike the pattern so as to allow the metal to flow into the vent. The bottom board is placed onto the drag, with care that it bears on the sand at all points. The

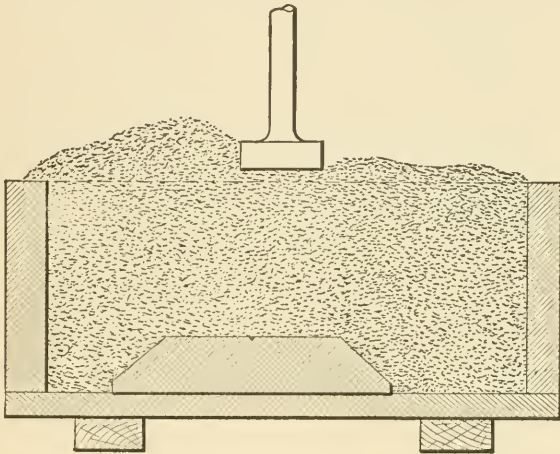

FIG. 4.

two boards are clamped to the drag with short clamps, as shown in Fig. 5. The flask is then turned over onto a bed of loose sand, so as to have an even bearing at both ends. The clamps are then removed and the board taken off, leaving the pattern at the top of the drag. The surface of the joint is made by tucking sand into any soft places that there may be, then riddle a little loose sand on the surface, and slick with a trowel so as to make it a little harder than the main body of the sand. Parting sand is dusted

over the surface of the joint until the entire surface is covered. That falling onto the pattern is brushed off.

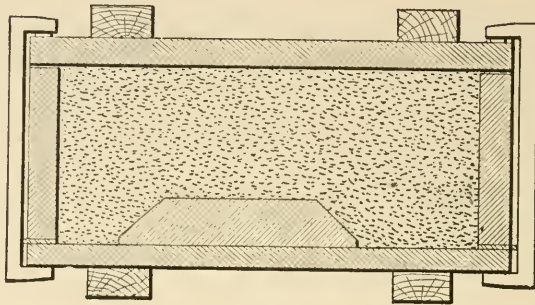

FIG. 5.

Since the flask is small and the cope has no bars, it may now be placed on and the gate stick set even with the centre of the pattern and midway between the flask and pattern, as shown in Fig. 6. This pattern having a rib

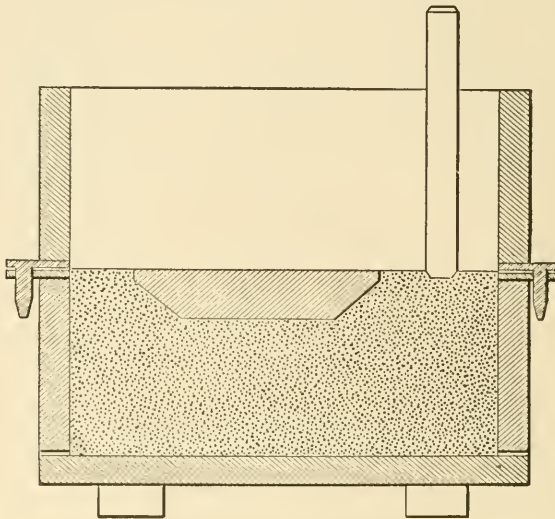

FIG. 6.

running lengthwise, the inflowing metal should enter the rib from an end and not over an edge. This will reduce

the liability of the metal cutting away the sand, causing a bunch on the casting. A little facing sand is riddled over the pattern, then the heap sand is riddled through a No. 4 riddle to a depth of about one inch. Heap sand is filled in and rammed next to the flask with the pein, then the remainder is rammed to an even hardness. The cope is filled and rammed with the butt rammer and struck off similarly to the drag. It is vented over the pattern and around the gate stick with one-eighth inch vent wire.

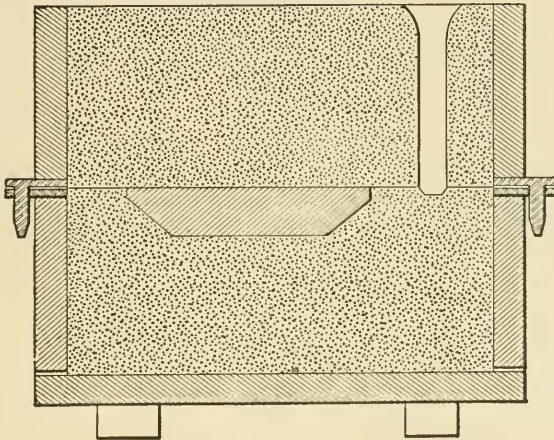

FIG. 7.

The gate stick is loosened by rapping sidewise and withdrawn. The hole is reamed out, leaving a large opening to pour the iron into, as shown in Fig. 7. The cope is ready to be lifted off and placed on any convenient rest where it may be finished. The cope should always be finished before the drag is touched, for, if anything happened to necessitate shaking it out, the drag is ready to have the cope replaced for another ramming. The portion of the cope that covers the pattern should be slicked lightly with the trowel, then covered with plum-

bago with a soft camel's hair brush, or by dusting from a sack and then slicking with a trowel. The gate should be reamed slightly to take off the loose edge and pressed to firmness with the fingers. The drag should be brushed off to remove the parting sand; then wet the sand around the pattern slightly with the swab. If the sand is too wet at any point the metal will blow when poured, therefore

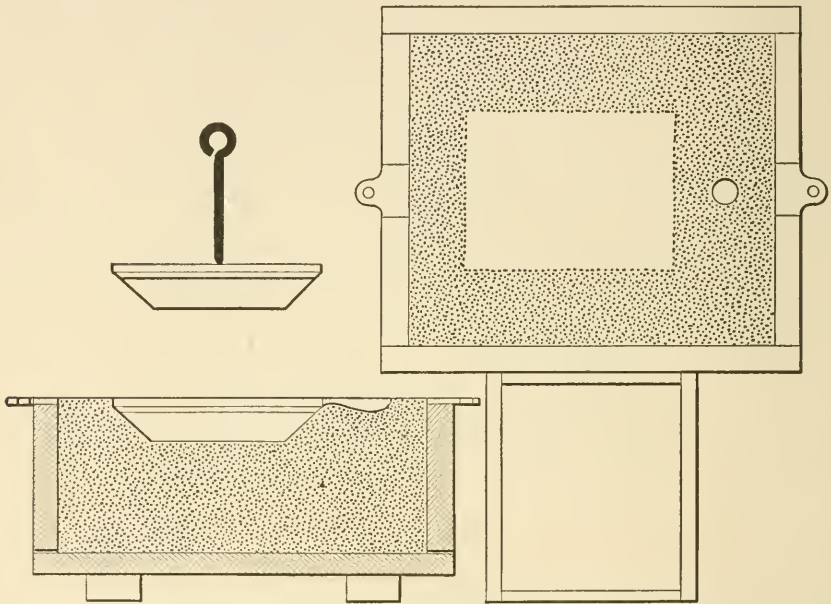

FIG. 8.

care must be exercised in putting on only as much water as is necessary to make the sand stick together well. The pattern may now be drawn by driving the draw spike into the centre of the pattern, then rapping it until the sand is free from the edges of the pattern; then lift the pattern out by slowly raising it, as shown in Fig. 8. The mold is slicked over lightly and patched in case the pattern tears

the sand at any place. The pouring gate is now connected to the mold by cutting a runner from the mold to the gate of a size that will admit the iron freely, but it must be smaller than the portion of the casting where it connects so that the runner may be broken off easily without damage to the casting. The runner should be smoothed with the fingers or a slicking tool to ensure

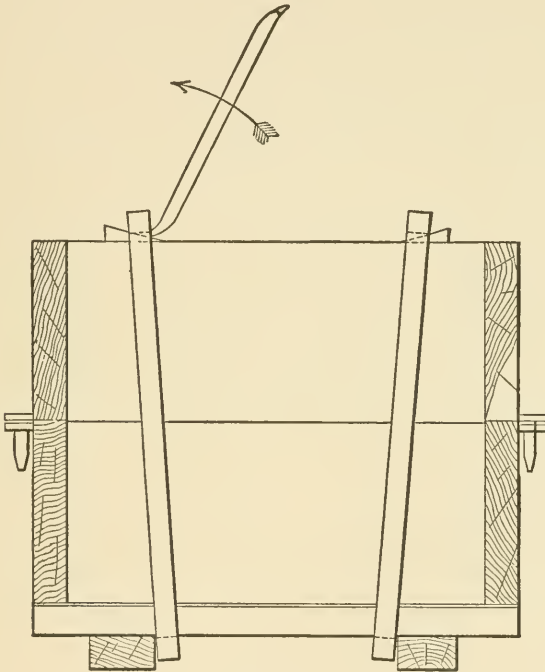

FIG. 9.

against loose sand being washed into the mold. The mold may now be dusted with plumbago and slicked, at which time the flask is ready to close. The flask should be clamped to provide against the cope being lifted by the metal and the metal flowing out at the joint when the mold is poured. In clamping a flask it must not be moved or

jarred, as the sand hanging at the top is liable to drop. Nor should the cope and drag be drawn together with a great pressure, as the flask is liable to give, causing the sand to crush the mold at the joint. The best method of putting on the clamps is to have them stand nearly vertical and resting on a wedge at the top. The clamp may be tightened with a clamping iron by catching the point under the clamp and on the wedge, then moving the upper end toward the clamp, as indicated by the arrow in Fig 9. The mold is now ready to cast.

The process of making a mold with a **split**, or **divided pattern** is shown by the small pulley in Fig. 10. The

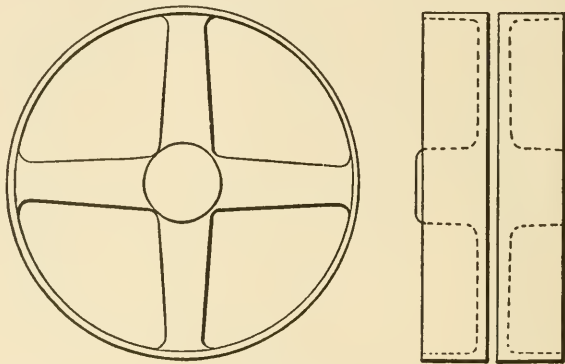

FIG. 10.

half of the pattern without the dowel-pins is placed on the turn-over board and the drag placed on it as in the previous case. The facing sand is put on until the arms are covered, then heap sand is riddled through a No. 4 riddle until the centre is filled to the top of the rim. Since the hub is deeper than the rim, there is liability of the sand crushing out when the mold is poured, as the hub fills to the height of the arms before the rim receives any

iron. To prevent the sand from breaking and to hold it together more firmly, wooden soldiers are put into the sand between the rim and the hub. The soldiers are made of any small pieces of wood, only large enough to be stiff and of a length to reach beyond the pattern about the same distance as it is inserted into the pattern. They are wet with clay wash, or flour paste, to hold the sand to the soldier. They are placed to a depth of the arms about midway between the rim and hub, and between the arms, as shown in Fig. 11.

The pattern is now completely covered with riddled sand and the outside rammed as before. The sand within

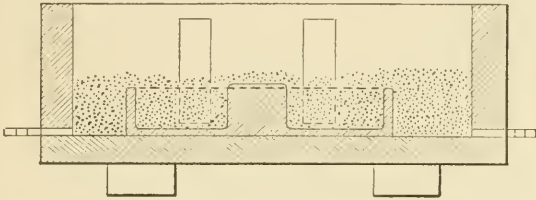

FIG. 11.

the pattern is rammed with any small tool or iron rod that can be gotten in between the soldiers and the pattern. The remainder of the drag is filled in, rammed and vented. The flask may now be turned over and the joint slicked as before. The other half of the pattern is put on as shown in Fig. 12. Parting sand is put over the joint, then the cope is placed in position. Pulleys and sheaves are generally poured from the hub, in which case the gate stick must be placed above the hub. The facing sand is put on the arms and hub, and riddled sand filled in over the pattern. Soldiers may now be placed in the

same manner as in the drag, but their office in this place is more to hold the sand from falling away when the cope is lifted off or closed after removing the pattern. The

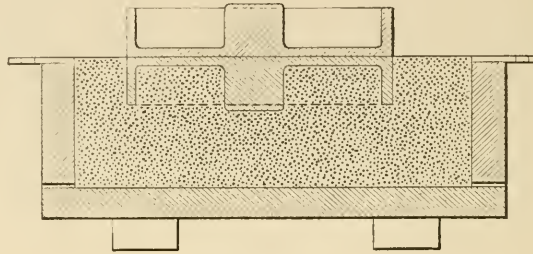

FIG. 12.

first ramming is the same as the drag, then the gate stick may be put in place and the ramming finished. The cope is vented, the pouring basin cut and the gate stick removed, giving the flask in form as shown in Fig. 13.

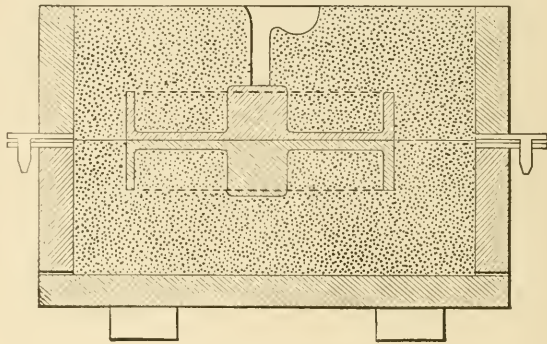

FIG. 13.

The cope is lifted off and placed on any convenient blocking, as shown in Fig. 14. The pattern in the cope is brushed off and lightly swabbed with water.

The pattern is rapped and removed by lightly jarring as it is drawn. The gate is reamed a little at the hub to

remove loose sand, then the hub and arms are slicked and blackened with plumbago. The drag is prepared in the same manner, then the flask is ready to close and clamp for casting.

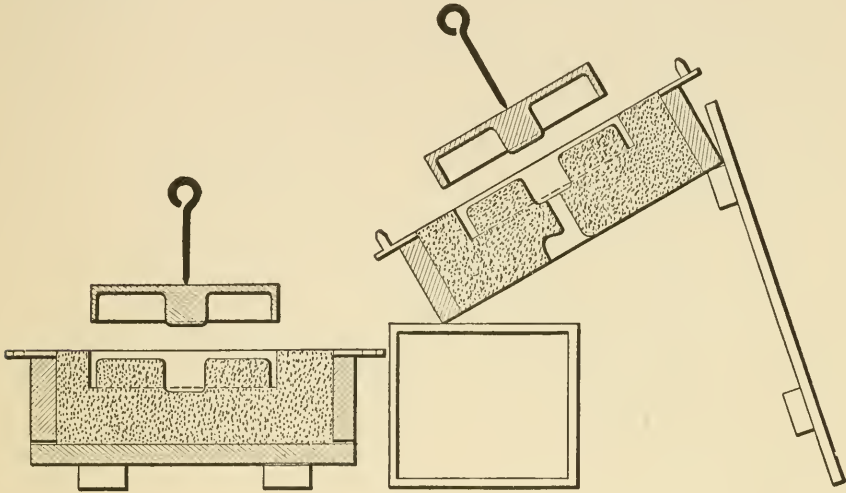

FIG. 14.

Many patterns have rounded edges or have the point of parting located at different levels in various parts of the pattern. In these cases the parting on the drag must be shaped to allow the pattern to be withdrawn without destroying the shape or tearing up the sand. The upper portion of the pattern must be formed in the cope. This causes a portion of the sand to be hung in the cope below the level of the flask, or the sand is **coped out to the pattern**. In cases of coping out, a portion of the sand is lifted from the pattern when the cope is lifted off. This does not admit of rapping the pattern or otherwise loosening the sand, therefore the sand must be well anchored so as to hold its form well and not require too much patching.

The pattern of the half of an eccentric strap, shown in Fig. 15, may be taken as an example where coping out is necessary. The pattern can not be drawn sidewise, as the inner circle has a flange on each side.

To cast this eccentric strap the pattern is placed in the drag with the inner circle toward the turn-over board, then facing is put on the pattern and the drag filled, rammed, vented, and turned over as in previous cases. The parting is now made even with the face of the drag at

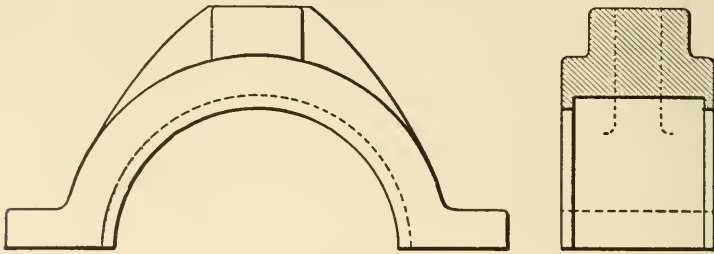

FIG. 15.

each end up to the edge of the inner circle. The parting surface then follows the outer edge of the pattern and the sand is sloped outward on each side, as shown in Fig. 16. This slope must be so as to allow the sand to part freely at all points when the cope is lifted. The dry parting sand is then placed over the level portion of the drag, but it will not stay on the slope. A good way to part that portion of the mold is to coat the surface with a fine, new, sharp sand, dampened so it may be slicked on with a tool, or the fingers; then dust a dry parting sand over this.

The cope for a pattern like this must have special bars following near to the shape of the pattern, as shown in Fig. 17. The bars must be dampened with clay wash or thin flour paste to make the sand stick to the bars.

Facing is riddled onto the pattern and sand riddled over the drag to a depth of about one-half inch. The flask joint is then cleared and the cope is put in place. The gate stick is placed opposite the centre of one end, while a riser is placed at the other. The offices of the riser are to allow the gases to escape from the mold, and

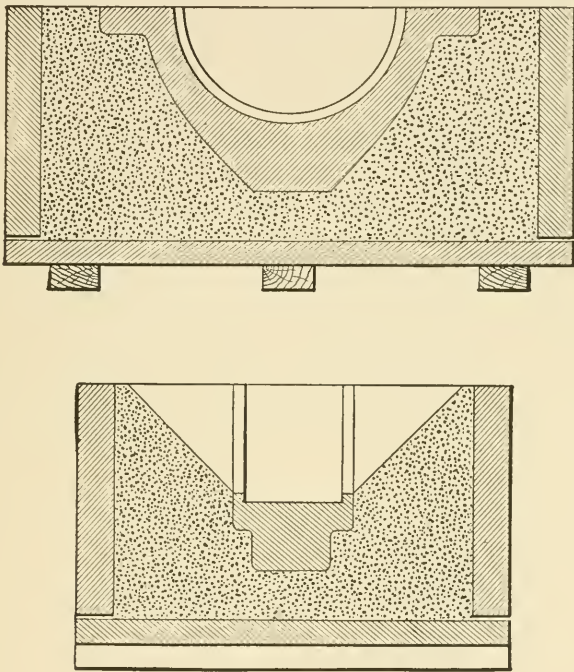

FIG. 16.

to furnish iron to feed the casting when shrinkage takes place.

Gaggers are then set in the cope as shown in Fig 17, and are placed near enough together to anchor the sand firmly in the cope. The sharp edge coming inside of the flanges may be better anchored by placing nails with heads toward the pattern at intervals of about one to two

inches. The nail heads should be clay-washed and set as soldiers. Sand is now riddled into the cope to a depth

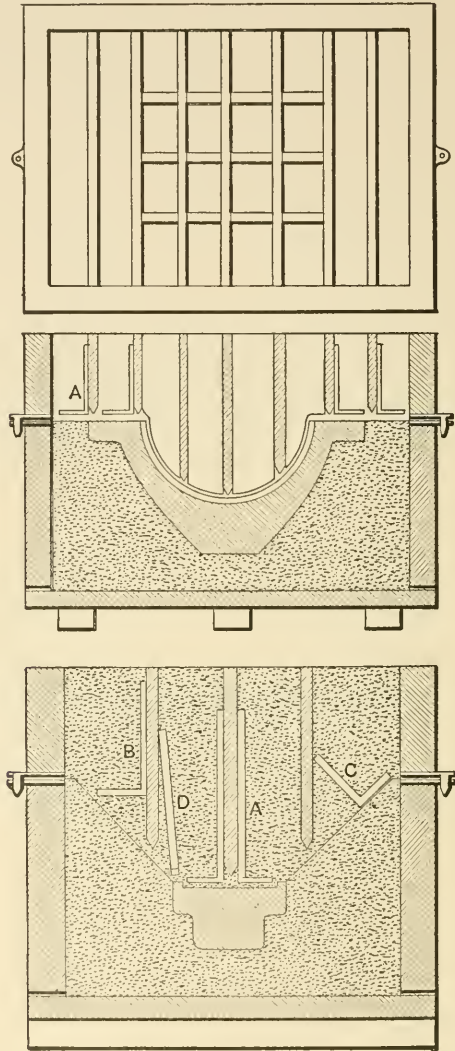

FIG. 17.

of two or three inches, then the bars are tucked with the fingers to harden the sand under the bars, the same as the

rammed portion between the bars. Sand is filled in to a depth of about six inches. The part enclosed between each set of bars is rammed separately, similarly to an individual cope, but using care to have all the divisions rammed to an even hardness. The remainder of the cope is then filled in and rammed, having about 6 to 8 in. of sand to a ramming, until the cope is entirely filled, when it is butted off and vented. In ramming, the operator must avoid striking the gagers, as that drives them into the drag and then necessitates patching when the cope is lifted off. The cope may now be lifted off, using care to lift it slowly and evenly, in order that the sand may not be torn by striking at any point. The cope should be gone over with the hand to see if there are any soft spots, which, when found, should be filled to an even hardness with other parts. It is then patched where necessary and slicked to a smooth surface. The pattern is drawn from the drag after removing all the parting sand and swabbing the sand at the edge of the pattern. The mold is slicked and the gate and riser connected to the mold by the runner. This gives the mold in the form as shown in Fig. 18. The mold may be blackened and closed, ready to be cast.

Many patterns are of such form that they require a special follow-board or match in order to mold them by turning over. When there are not enough castings required to pay to make a follow-board, other means must be resorted to. If these are of such form that they may be evenly rammed by **bedding in**, that method often saves much time.

To mold by bedding in is to place the drag in the posi-

tion it is to have when the cope is put on, then ram the sand in until it is of such a height as to bring the parting of the pattern at the parting of the flask, and finish the ramming of the drag with the pattern in position. Many forms of patterns easily admit of this method in that there are no parts that are not easily accessible for ramming the sand from the top side. Other patterns may be such that a molder may easily patch any soft spots that are under the pattern when finishing the mold.

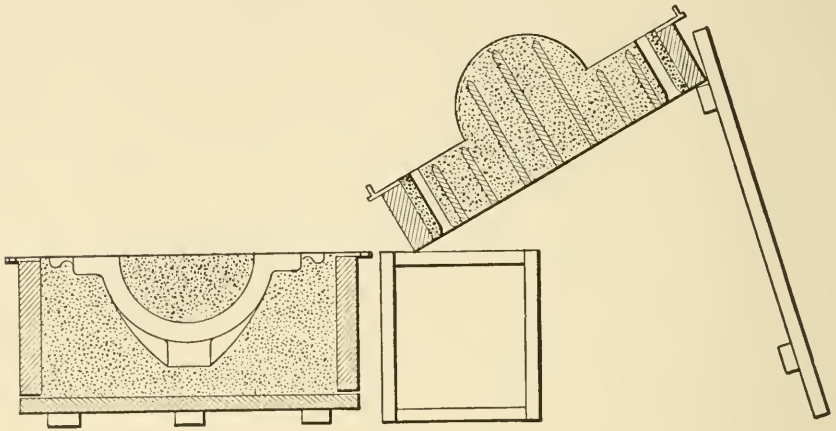

FIG. 18.

In some places the main portion of the molding is done by this method, but on the majority of patterns it is easier and quicker to prepare the drag by turning it over. In England, where iron flasks are used the main method used is that of bedding in due to the weight and to the difficulty in turning over the flask.

The molder must use his discretion in deciding which method he should use, in order to save time and labor. Different men making a mold from the same pattern

may be able to do the best and quickest work by using opposite methods, according as each is most accustomed.

One type of casting that may best be made by bedding in may be illustrated by the making of a large plain plate by use of the frame shown in Fig. 19. The pattern is made in frame so as to be able easily to ram the sand which comes under it. The narrow frame may easily be tucked to the required hardness, while if a solid pattern be used an even hardness is much more difficult to obtain.

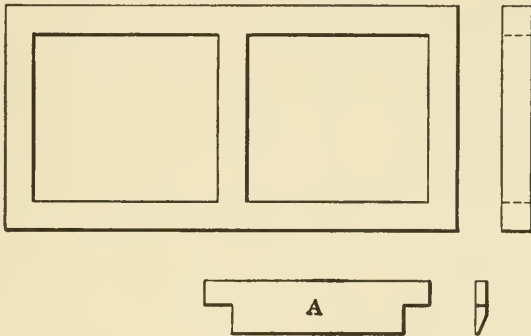

FIG. 19.

In making the mold the drag is placed on the bottom board in the position to receive the cope. Sand is shoveled in and rammed to a depth that will hold the top of the pattern nearly to a level of the parting of the flask. Sand is then riddled into the drag to a sufficient depth for putting the pattern in place and tucking the sand firmly under it. The pattern is placed in position and forced to the level of the drag, then it may be held by placing a weight on it to avoid raising while tucking sand under it at the soft places. The remainder of the drag is rammed to the parting. The drag is well vented before making the parting, thus closing the top of the vents and forcing

the gases out at the bottom board. The cope is placed on, rammed, and lifted by observing the precautions previously given.

In order to make a plate of the mold, the sand within the frame must be taken out to a depth equal to that of the pattern. In order to make this of even depth, a strike stick, as shown at A, Fig. 19, is used to strike out the sand. The pattern is then removed and the surface is slicked to an evenness, using care not to cause hard spots. The mold may now be blackened and runners cut, when it is ready to close.

When a mold is made in the sand on the floor without a cope to cover it, it is called **open sand molding**. This is a cheap form of molding for some types of castings. The casting will not be clean or smooth, but may have its exact form all except the upper surface.

This method may be used for making castings for parts of iron flasks, clamps, core irons, floor plates, or castings whose upper surface may be rough and where the exact thickness of metal is not important.

Many of the precautions necessary to obtain a good casting from open sand work may be noted in the procedure for making the flask bar shown in Fig. 20. The manner of making molds of this style varies, as is most convenient with the material the molder has at hand. The method given below is most flexible and may be used on a great variety of patterns. Particular cases may be handled in very different manner.

The top surface of the pattern must be level in all directions, for the metal when poured is a liquid which seeks its level. The metal lies on the sand with only the thick-

ness of the casting. Since there is no head, as in gates and risers, to give a pressure, the sand must be open and well vented to give a free escape to the gases; or they will force through the iron and cause the sand to cut away, making a bunch on the casting, or leaving blow-holes through the iron.

The pattern here shown has the lower face a plane except for the flanges at each end. We may therefore make a level bed and place the pattern onto it. To make the bed two straight pieces, preferably T-rails, are placed on the floor and leveled. One piece is placed down and

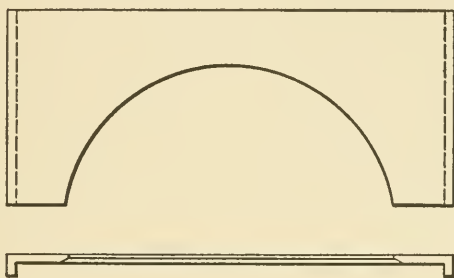

FIG. 20.

leveled with a spirit level, then the other is laid parallel with it at a distance that will give ample room to locate the pattern, with the pouring basin coming at the edge of the bed. This piece is made level with the first by use of a straight edge resting on each piece and the level on the upper parallel edge of the straight edge. Sand is filled in almost to the top of the pieces and rammed lightly to an even hardness. The remainder is filled with riddled sand and struck off, having pieces about $\frac{3}{8}$ inch in thickness between the strike stick and the rails. To ram, the rails are cleared, then by holding the strike stick firmly on its

edge on one rail and striking down with the other end until the sand is compressed to the level of the rails. This ensures even hardness. Unless the sand is very open, the bed should be well vented downward with cross vents, allowing the gas to escape to the sides. The bed is then struck off with a straight edge resting on the leveled pieces, thus giving an even and level bed.

The pattern is then placed on the bed in the position most convenient for pouring. It may be driven down part the depth of the flange, then drawn out and the depression of the flanges cut with a trowel to soften the sand, to avoid its becoming too hard when the pattern is forced down to the bed. The pattern is replaced and forced down to a bearing on the bed. The edges may then be tucked a little to harden the sand on which the edges rest. Sand is filled in and tucked with the hands around the pattern until the sand is above its top. The top is struck off even with the pattern by any short straight edge, and the surface slicked with a trowel. The pouring basin may be built at the end by making a U-shaped mound of sand with the enclosed portion tapering down away from the edge of the pattern. The object of this depression is to hold some metal on which the inflowing metal strikes instead of on the sand.

The pattern may be removed from the mold after swabbing the edge and rapping to free the sand. The bottom is slicked smooth with the trowel, care being used not to make hard spots. The flange may be patched to proper shape whenever necessary, then the mold is ready to receive the metal.

In the case of coring holes through the plate, the prints may be on the lower side of the pattern when placed on the bed. The cores near to the entering metal should be supported by nails to avoid washing out by the flow of the metal. It is a good plan to put a few nails at the edge next to the basin to prevent its breaking in when poured.

Many castings require dry sand cores for making holes and openings in the castings that are solid in the pattern. In these cases the pattern has a print which locates the core and holds it in position in the mold. The core must be vented off in the mold to allow the gases to escape freely. It must be properly anchored by bearing on the sand or by chaplets to prevent its floating when the iron surrounds it in pouring.

Some of the principles involved in **setting cores** are illustrated in making the casting shown in Fig. 21. This is the casing for a threadstock whose body part is hollow and having the bearings cored for babbit.

The pattern used is shown in Fig. 22. This is a one-part pattern having loose pieces for the projecting parts. In this case the loose pieces are held in place by a dovetail. Usually loose pieces are pinned onto the pattern. In cases where loose pieces are pinned on, the sand is rammed around the loose piece, then the pin is drawn, leaving it free from the pattern when it is withdrawn from the mold.

The drag and cope are rammed in the usual manner of a common mold. When the pattern is drawn from the drag, the loose pieces remain in position in the sand, as at A, Fig. 23. The mold should be patched and finished before drawing the loose pieces. The edge of the large

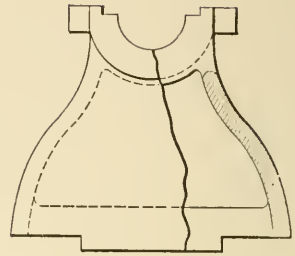
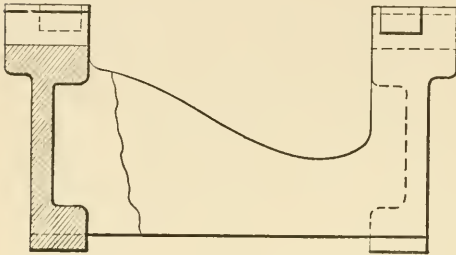
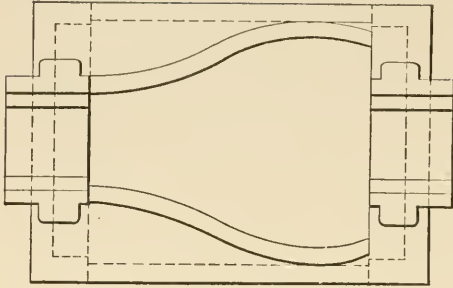

FIG. 21.

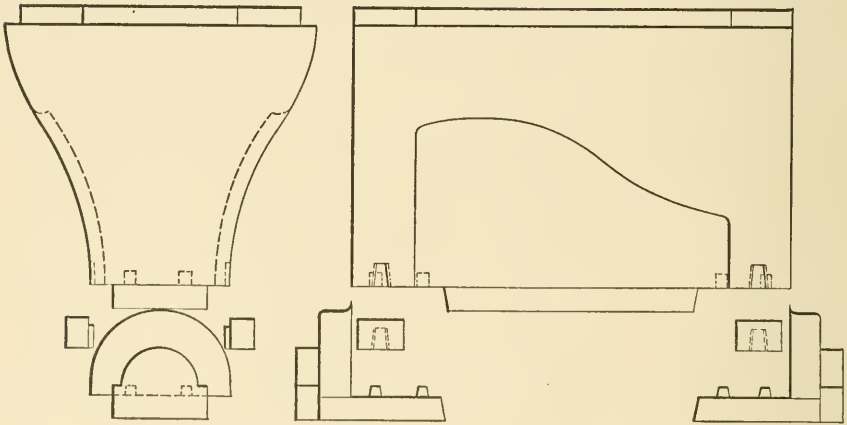

FIG. 22.

pieces should be nailed with short nails to prevent tearing or dropping when the piece is removed. The nails should be slanted away from the pattern and pressed in so the head comes even with the surface. The loose piece is then loosened from the sand by rapping, and drawn into the mold, as at B, Fig. 23. These new parts are then finished and the mold may be blackened all over.

The cores are placed into the mold after the manner shown in Fig. 24. The cores are vented off at the bottom

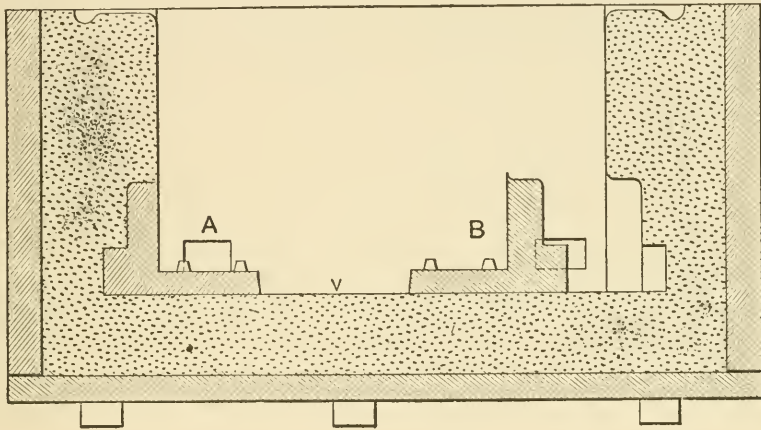

FIG. 23.

by running a vent wire down from the print, then inserting another wire on the bottom board to strike the former. Several vents must be made in this manner to ensure free escape of the gases. This being a compound core, those at the bottom must be set first. The small bearing cores go into the opening left by the print on the loose pieces A and B, Fig. 23. The main core has a bearing on each of these cores and is held in place by the side of the mold which was formed by the main print of the pattern.

The upper vents of the core should be closed with sand or flour to prevent the metal flowing into the vent if it should get above the core. The print in the cope holds the upper side of the core in position, thus preventing the liability of moving sidewise when the mold is cast. The mold may be closed when the gates and runners are properly cut.

Many patterns are of such form that they can not be drawn from a two-part flask, in which case an intermedi-

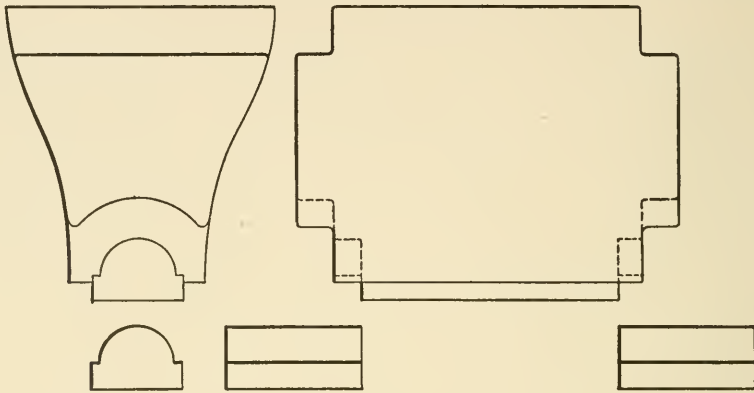

FIG. 24.

ate portion called a cheek is required. This branch of molding is generally known as **three-part work**. The flask used and the methods of procedure are dependent upon the pattern. These are greatly varied.

To illustrate one of the general forms using a "plain cheek," we have taken for an example the piston spider for a Corliss engine, shown in Fig. 25. The pattern, as shown in Fig. 26, is in two parts. The main or body consists of the outside ring as shown in the figure. The other portion consists of the centre hub with web con-

necting it to the ring. The bosses in the pockets are loose and pinned onto the body portion of the pattern.

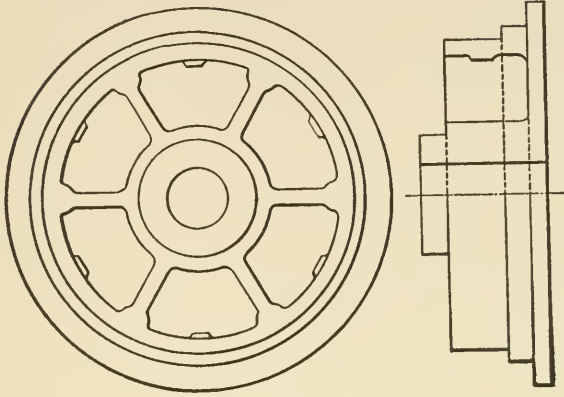

FIG. 25.

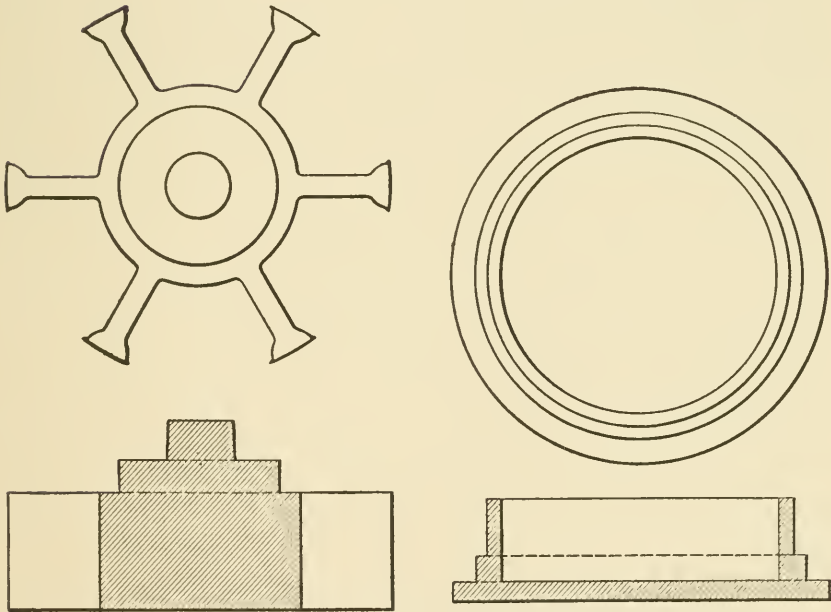

FIG. 26.

To ensure a firm, clean casting, it is advisable in this case to run some metal through the mold after it is filled.

The mold is poured from the bottom, thus providing a skim gate and allowing the metal to rise in the mold without flowing across the overhanging portion of the cheek.

To form the mold, the pattern is placed on the follow-board with all the parts in place. Facing sand is put into the pockets to a depth of about 2 in. Long rods are placed in the pockets to securely anchor them in the cope. Fill in about 2 in. more of facing and ram lightly with a rod or stick, using care to avoid making the sand too hard. The remainder of the pocket is filled and rammed. The pins may be removed from the bosses. The pockets should now be thoroughly vented, using a needle wire smaller than $\frac{1}{16}$ in. in diameter.

The cheek may be placed on the follow-board about the pattern. The gate stick is placed in its position outside of the pattern. The cheek is now rammed and the parting made at the upper edge of the ring. The cope may be placed upon the cheek. The pouring gate from the cheek extends through the cope, and a flow-off gate is placed on the centre hub beside the centre core. The cope is rammed, ensuring proper anchorage for the rods from the pockets. It should be well vented, especially above the pockets. The gate sticks are then removed. A bottom board is placed upon the cope, the flask firmly clamped together, and the whole turned over. The follow-board is removed and the lower parting made on the cheek.

The core print is placed on the pattern. The drag is rammed, having proper anchorage for lifting it off. After venting the drag is lifted off and placed on a bottom board bedded for receiving the flask. The drag is slicked

and finished. The surface directly in front of the gate is nailed to prevent the iron from cutting away the sand.

The body portion of the pattern is drawn from the flask. The top of the cheek is finished and the runner cut to connect with the pouring gate. The cheek is lifted off and completely finished and blackened, then placed in its position on the drag. Before removing the second portion of the pattern from the cope, the edges of the pockets should be well nailed to better anchor the sand. The pattern may now be drawn and the cope finished and blackened. After setting the centre core, the flask may be closed. The gate sticks are replaced in their respective positions, in order to form the overflow runner and the pouring basin, which must be higher than the flow-off gate. To prevent closing the vents in the cope, when the flow-off gate is made, the surface is covered with paper, hay, or any convenient material. The gate is made with a runner to conduct the overflow from the flask. After clamping it is ready to receive the metal.

In some cases it is found that dirt accumulates in the flange directly above the gate where the metal enters. It acts as a whirl or retaining point that is not forced to circulate as the metal is flowing into the mold. To avoid this, it is advisable to put a top gate on the opposite side of the centre core from the flow-off gate.

Many forms of patterns requiring three-part flasks are such that the "cheek can not be lifted." In such cases the lower portion of the pattern is drawn and that part of the mold finished before the drag and cheek are rolled over.

The lathe bed casting shown in Fig. 27 gives a good example of this class of work. The pattern has the two upper rails loose with the fillets attached forming the guides to hold them in place.



This casting may best be gated so as to allow the metal to enter at both top and bottom rails, thus reducing the liability of the metal cutting, from too great a flow at the bottom or by falling from the top of the mold.



FIG. 27.

The cheek is placed on the follow-board and the pattern placed with the cope side down, in which case the loose rails come on the upper side. The gate stick is placed in position so that runners may be cut to the lower rails. The pattern is then faced on the outside and rammed in the usual manner. The inner portion will be a green sand core which is separate from the flask and has bearing at top and bottom. In the centre of each should be placed a vent rod to give an opening for carrying off the gases. The sand is filled in and rammed to a depth of about four inches. Rods are now laid in diagonally to bind the sand together. Use facing next to the pattern and riddled sand for the remainder. Each succeeding ramming of from 2 to 4 in. should be well rodded laying them in different directions each time. When the cross webs of the pattern are covered, it is best to place two or three long rods in to bind the whole core together.

When the cheek is finished the parting is made even with the top of the pattern. The face of this parting

should be harder than in the previous cases, because the pressure head of the metal is very great as this comes at the bottom of the mold. A good method of getting this parting of even hardness is to riddle some sand onto the surface to a depth of about 2 in., then butt in firmly but not hard.

Strike it off with a stick, then slick with a trowel after riddling on a little sand over the entire surface. The gate stick should come to this surface but not extend beyond. Parting sand is put on and the drag rammed, vented and lifted off.

The cheek should be well vented on the outside of the pattern and under the rail that is about to be drawn. These vents should be led off to the parting of the flask. The centre portion should have vent gutters cut around within about 2 in. of the pattern and leading to the centre vent rod of each of the cores. The vents are all made to extend from this gutter. The wire should be $\frac{1}{8}$ or $\frac{3}{16}$ in. in diameter. Vent particularly under the rails and around the centre web.

The parts of the pattern are drawn. The edges of the fillets near the web or the part of the pattern still remaining in the mold should be nailed, using tenpenny nails and placing them about 2 in. apart. The mold is then slicked, blackened, and gates cut from the rails to the gate stick. The drag is then closed onto the cheek. Sand should be thrown onto the top and struck off evenly. This may be easily accomplished by using a straight edge with a gagger or strip of wood under it and bearing on the flask. The bottom board is placed on and rubbed to good bearing, then the flask is clamped together firmly and turned over,

using care not to strain the mold. The follow-board is removed and the upper parting made on the cheek.

The cope is then rammed, having a riser opposite the gate and the vent rods drawn up to give opening through the cope. This is lifted off and finished in the usual manner. The cheek is vented under the rails on the outside of the pattern and the vents led off to the parting. In venting, do not endanger forcing the wire into the lower part of the mold where the pattern has been removed. In the centre portion, vent gutters should be cut around each core and led to the centre vent; then vent the core to lead to these gutters. The pattern may now be drawn and the mold slicked and blackened. Runners are cut to connect the rails to the main gate. The cope may be closed, the pouring basin made, and the riser built to the same height.

In this mold there is a depth of metal which causes a pressure against the side. This must be provided for in clamping the mold. A tie clamp may be placed over the flask, having the parallel ends long enough to reach to the bottom of the cheek. Wedges are placed between the clamp and the flask, and forced to a firm bearing, but must not spring the flask. These may be driven in hard enough by striking with a hammer handle. In these cases, be very careful not to put great pressure at the sides, for the flask will be forced together, making the metal of the web too thin or causing the cheek to cut through the core.

In making many castings much time may be saved by making "three-part work in two-part flasks." This may be accomplished by using a cover core over the bottom

division of the mold when that is a plane surface. In other cases the cheek portion may be made in the sand alone. This latter form may be shown by the sheave-

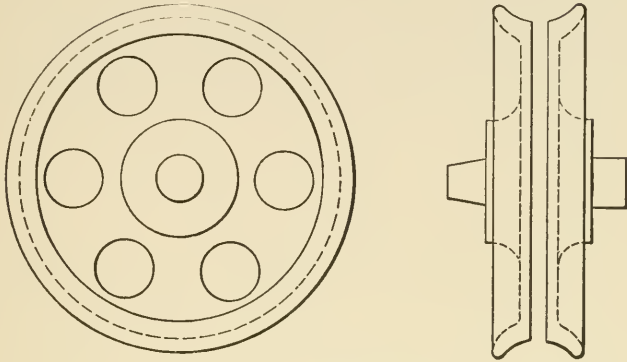

FIG. 28.

wheel made from the pattern shown in Fig. 28. There are two other methods of making this, and the method

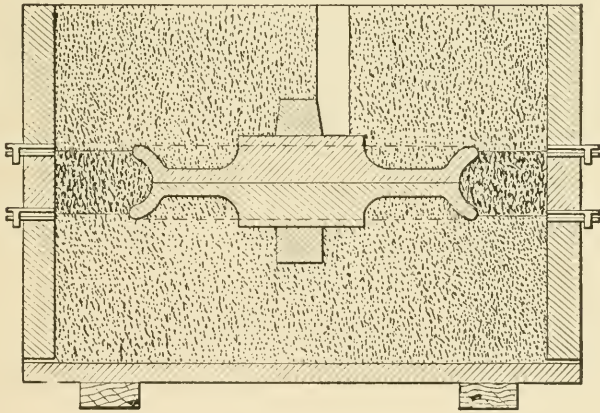

FIG. 29.

chosen depends mainly upon the size of the wheel to be made. Fig. 29 represents a three-part flask with the cheek so it may be lifted. Fig. 30 is a two-part flask

having the third or cheek made in core. After the pattern is drawn out, cores of the form shown at A are set in the place of the print on the pattern. This method is of great convenience when there are two or more grooves in place of the single groove here represented.

The pattern is made in halves, as shown in Fig. 28. The

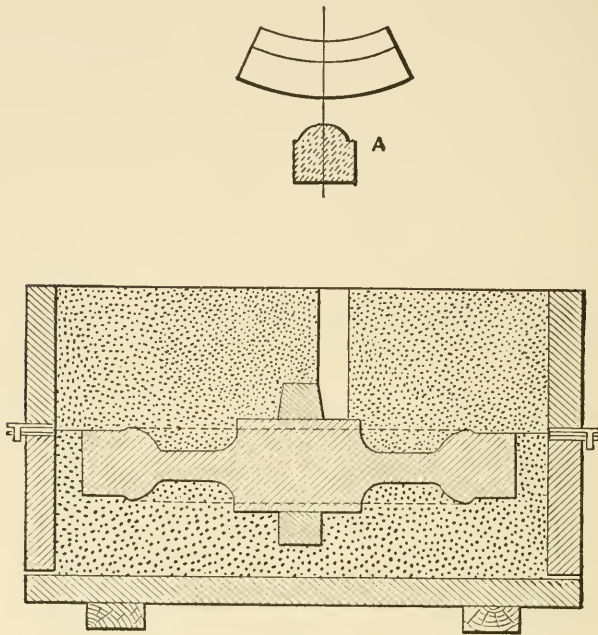

FIG. 30.

process of molding would be to ram the cope as usual with the pattern in the centre of the flask, as shown in Fig. 31, having the gate stick placed on the hub. The flask is turned over and the parting made to slope down to the parting line of the pattern, as shown in Fig. 32. The other half of the pattern is put in place and weighted so as to ensure its remaining in place while the cheek is made.

The cheek is made by tucking in about the pattern until filled, so as to make the upper parting as shown in Fig. 33.

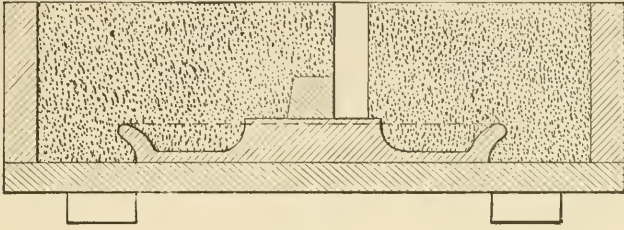

FIG. 31.

The drag may now be put in place and rammed. It must be sufficiently anchored to allow lifting off.

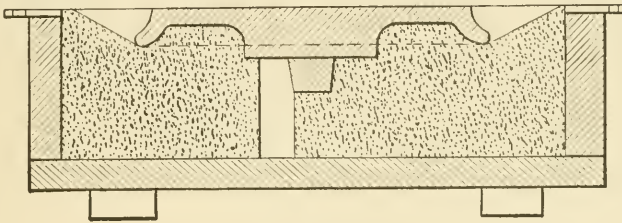

FIG. 32.

The drag is then lifted off and that half of the pattern drawn and the mold slicked and finished, as shown in

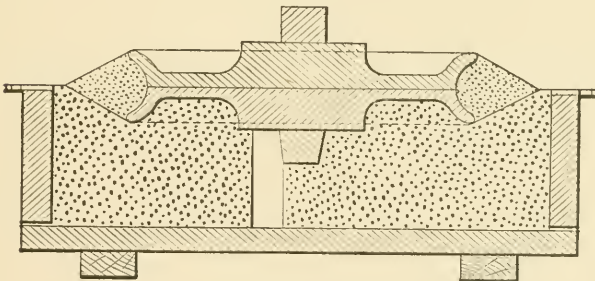

FIG. 33.

Fig. 34. The drag is replaced and the bottom board given a firm bearing by use of loose sand on the flask,

then turned over carefully onto the bed where it is to remain. The cope is now lifted and the remainder of the pattern drawn and the mold finished. In lifting a part of the flask where the pattern is lifted with it, a draw spike, or wood screw, should be put into the pattern and held when the flask is lifted. The centre core is set, then the mold may be closed. A pouring basin should be built on the runner so that the iron may strike in the basin in-

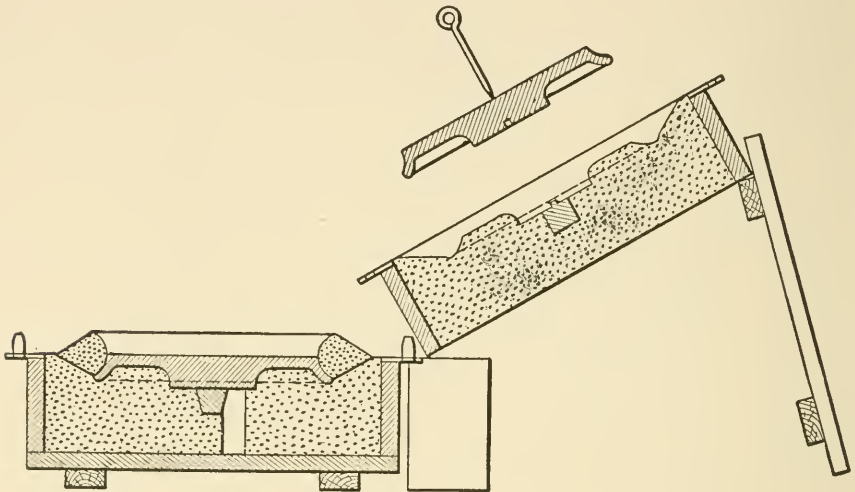

FIG. 34.

stead of directly into the gate. This breaks the fall of the iron from the ladle and relieves the straining pressure on the mold, besides acting as a skim gate when the basin is kept full. The dirt and slag float on top, while the clean metal enters the mold from the bottom of the basin. This gives the mold as shown in Fig. 35.

The use of cores for covering part of the mold instead of a third part to the flask is found to be of great advantage when making large base-plates for columns. Fig. 36

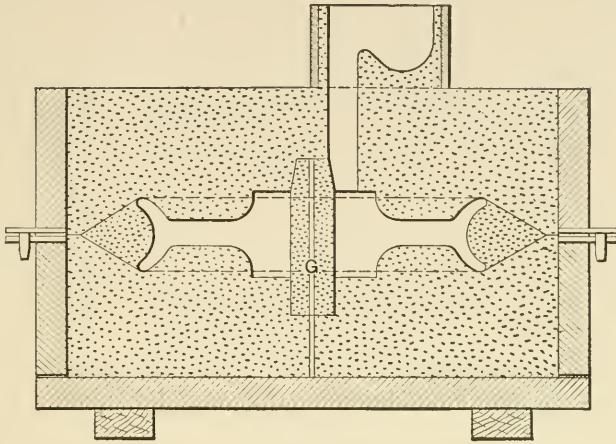

FIG. 35.

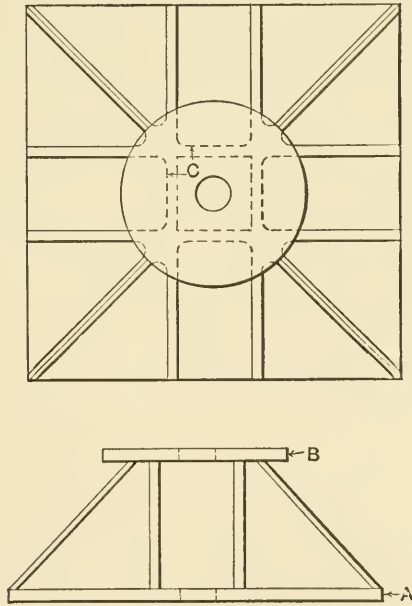

FIG. 36.

shows a base-plate casting which may be made by use of cover cores.

The pattern for this casting has the top and bottom pieces doweled to the centre piece and the ribs, while the ribs are also separate from one another. The pattern in its complete form is placed on the follow-board in the drag. The bottoms of the pockets are faced and filled with sand to a depth of about 3 in. This is rammed lightly, then long rods are laid in horizontally, extending out to the flask. Two rods should be placed in near the corner of each pocket and slanting upward to just allow room for the cores to be placed on the top without striking the rods. These rods should not strike the pattern. The buoyancy of the metal, acting on the bottom of the sand which forms the pocket, is held by these rods placed in the sand. This buoyancy, or lifting force, acts on the surface exposed by the lower plate proportionally to the area exposed and the height of the pressure head. About 3 or 4 in. of sand is filled into the pockets and rammed about the rods with a small rammer, care being used to have the rods firmly rammed into place and not sprung so as to tear the mold when the pattern is drawn. The sand should be well vented in the pockets and a coke bed for collecting the gases laid into the pockets and leading to the flask where the gases may escape. The coke bed is covered with sand to a depth for ramming, then a number of rods should be laid in horizontally as before.

Much time may be saved in molding if cores are made to fit the pockets next to the top plate and of a thickness of about 2 in. These cores should extend out to a distance of 3 in. beyond the plate B. This prevents the

green sand from breaking when turned over. The sand below the cores should be well vented to the coke bed and have a firm, even bearing all over. When no cores are used, rods should be laid in near to the plate and the sand well rammed and vented to the coke bed. After removing the plate the edges should be well nailed before replacing the cover core.

The flask is now filled to the plate B. This is left in place and sand rammed in and a surface made even with the top of pattern. When a special cover core is used, it should be put in place determined by the centre print and the edges marked in the sand and guide rods placed at the corners to ensure replacing to the proper position. The core is now lifted, the pattern drawn and the mold finished in this portion. The cover core is replaced and the remainder of the drag filled, rammed, and vented, ready to turn over.

When no special cover core is provided, an extra piece may be made for the pattern coming to the edges marked C in the figure. This may be drawn from the other side of the mold. In this case, after the surface is made even with the top of the pattern, the plate B is drawn and this piece is placed on the pattern with the centre print. Stock slab cores may be used to cover the mold in the place of the cover core.

The drag is turned over, the parting made, and the cope rammed, having a gate at the centre of one side and a riser at another side. The large plate A is drawn first and the faces of the pockets finished. The front corners should be nailed with large nails and a few placed along the sides to prevent the sand from cutting, cracking off,

or scabbing when the mold is poured. The ribs may be drawn separately and the centre square last. The gate should be cut opposite the ribs, thus reducing to a minimum the liability of cutting.

When the bottoms of the pockets overhang quite a distance, it is advisable to put double-end chaplets between the core at the bottom of the pocket and the cover core. This takes the weight of the core and prevents it from sagging when the flask is turned over. The lifting pressure may be greater than will be held by the rods that are placed in the pockets. In this case, a plate of thin cast iron may be placed on the top of the pocket and a chaplet run through the cope to bear on this plate. The chaplet should be wedged only tight enough to prevent giving, but not so as to endanger cracking the green sand. Another manner of chapleting these pockets is to use a double-end chaplet with plates on both sides or very large heads. The chaplets should be such that the distance between the two outer faces exactly equals the thickness of the plate A. The plates on the chaplets are necessary since they bear on green sand, and small heads would cut through without offering much resistance.

Pulleys having a face of any desired width may be made by use of a pattern ring which is drawn up in molding to the width desired. The pattern consists of a pattern ring, as shown in Fig. 37, the arms with the desired hubs, and the core prints. Making the hub separate from the arms allows putting any sized hub desired onto the one set of arms.

The mold is made by the method of bedding in. The drag is placed on the bottom board and rammed with

sand nearly to the height that the pattern ring should be placed. Riddled sand is put in to a height such that the ring will bed into it. The ring is then bedded down to such a distance that the width of the ring plus the dis-

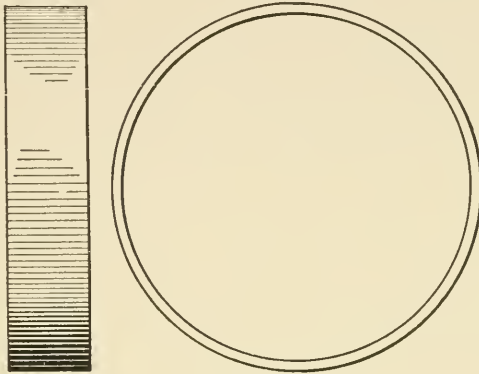

FIG. 37.

tance A, Fig. 38, will equal the desired width of face plus the finish on the pulley. The sand is then rammed around the ring nearly to its top. This should be well

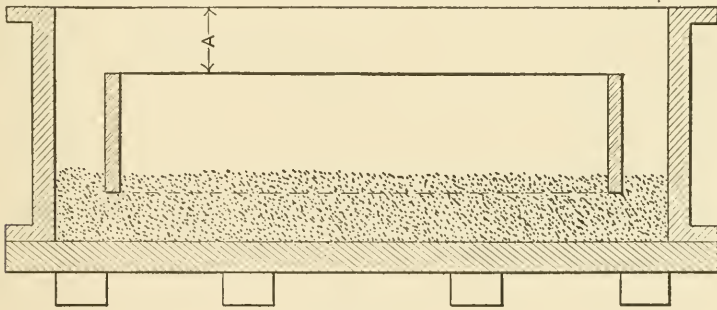

FIG. 38.

vented all over before drawing up. The ring is then drawn up about 2 in. by placing blocks at three or four points about the rim and extending above the ring an even height on each one. This keeps the ring even when

drawn to a level of the blocks each time. In ramming, the sand must not be too hard about the ring or the iron will not run the rim full. Usually direct the rammer slightly away from the ring rather than toward it.

The arms should be positioned when the ring has been drawn to half the width of the face of the required pulley. The arms are bedded in and the parting made from the centre line of the arms having the sand between them come to a level of their top, giving the flask as shown in

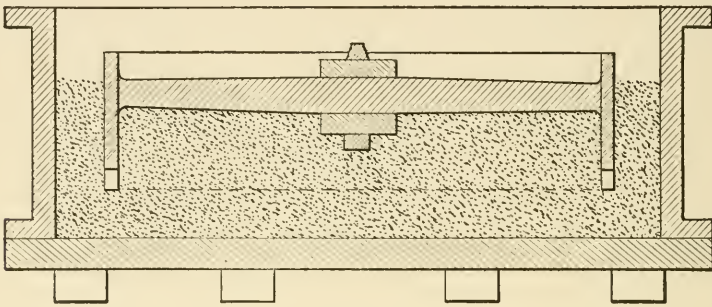

FIG. 39.

Fig. 39. This is to prevent having a heavy body of sand hanging below the anchor.

Sand is riddled over the parting and the anchor placed in position. The anchor, as shown in Fig. 40, has the three nuts for the screw eyes which are for lifting the anchor. These screw eyes are left in place until after the cheek is rammed, then they are removed and the holes covered for ramming the cope. The outer circle of the anchor must be smaller than the inside of the ring to allow for the contraction of the rim when cooling. Pieces should be put in to guide the anchor back to the same position after removing from the mold. These may be short cones

or square pyramids. They are placed in two or three places between the arms and extending below the parting. They are fastened so as to ensure remaining firm in the anchor. These pieces are often called pulley feet. Around the edges of the anchor nails should be placed to extend nearly to the pattern and firmly anchor the sand about the edges and the arms. The remainder is filled in, rammed, and the pattern drawn until the parting is reached at the

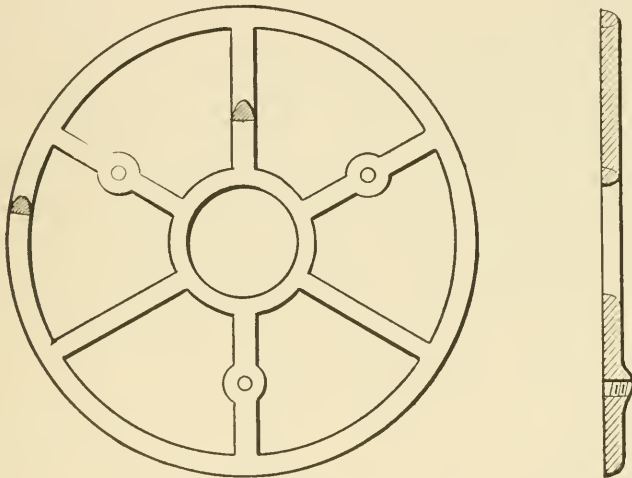

FIG. 40.

top of the drag. Two small gate sticks are placed on the hub for admitting the metal. The flask is ready for forming the parting, as shown in Fig. 41, and for placing on the cope for ramming.

The cope is rammed, having the two centre gates, a riser on the rim, and a vent opening from the cheek. The cope is lifted and finished.

The vent gutter is cut around the outside of the cheek within about 2 in. of the ring and connecting with the vent

opening in the cope. Slant vents lead to the gutter from all parts of the cheek. The outside is vented and led to the parting of the flask. In venting the wire must not be forced deeper than the pattern ring, because it would break away the face of the mold. The pattern ring is drawn out and the screw eyes are replaced into the anchor and the cheek lifted out. The arms may then be drawn, giving the mold in parts, as shown in Fig. 42. These may be finished and replaced, then the mold closed.

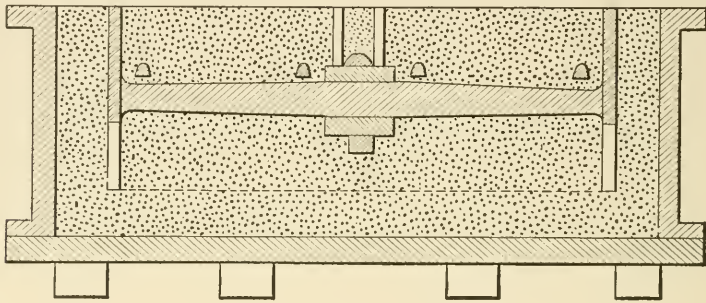

FIG. 41.

A pouring basin should be built to allow pouring from the outside of the flask. The riser should be built to the height of the basin to avoid overflowing onto the flask.

The methods above given may be used for many forms of pulleys and sheave-wheels. Double-arm pulleys may be made in this manner by using a second anchor to lift the cheek from the lower set of arms. The thickness of the rim may be increased by placing thin strips inside of the ring. In pulleys having wide face it is best to anchor the sand in the outside of the flask so that it may be lifted off. The face of the pulley, the inside of the

rim, and the bottom of the rim may be finished easily when thus removed.

For making sheave-wheels by use of the pulley ring the grooves are made in core. Sheaves having from 1 to

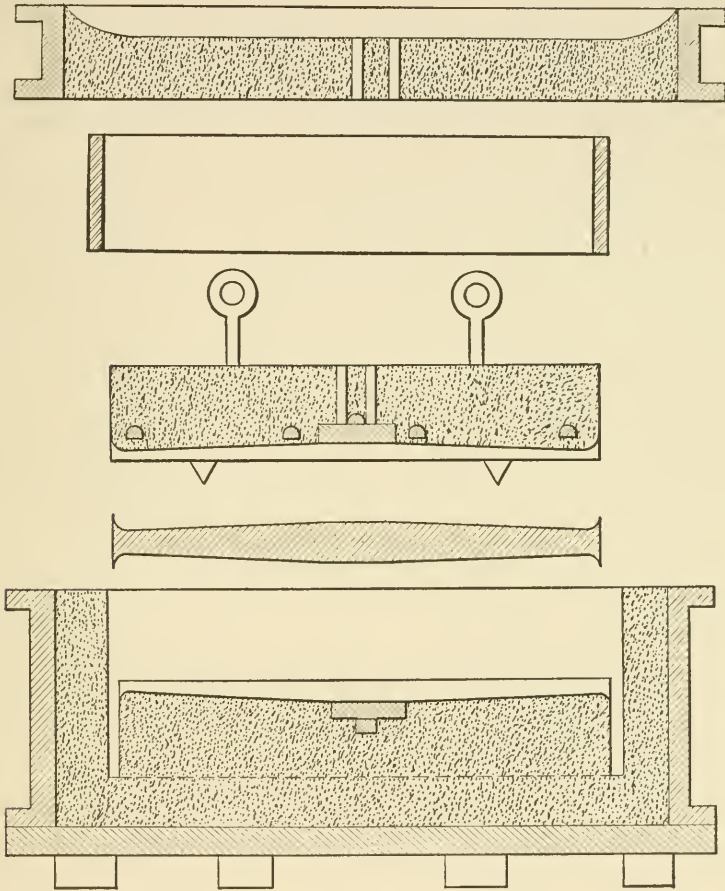

FIG. 42.

3 grooves are made without using an anchor lift, by coping out the sand above the arms by a cope lift. In making a sheave, the method of procedure is the same as that of a pulley until the cope is lifted off. The

sand on the outside of the pulley ring is then removed to a depth equal to the width of the cores which form the grooves. The centre part is finished as in the case of the pulleys. The cores are set about the cheek by use of strips which are the thickness of the metal below the grooves. The sand is filled in back of the cores, thus forming the outer face for the desired sheave. The strips are drawn out and the mold prepared for closing.

Columns are cast with centre cores of such a size that the thickness of metal on the outside is that desired. Fig. 43 shows a column that is here taken to explain some of the methods for making such forms of castings.

The pattern used is shown in Fig. 44. It is a halved pattern longer than the desired casting and having the brackets loose. The drag is rammed in the customary manner. Facing is used all over the pattern when the length and thickness of metal will allow without cold-shotting the end away from the gate. The ramming must be even throughout its length, and is best made much harder than on smaller castings. The parting is made and the other half of the pattern is placed in position. Facing should be put on, the same as in the drag. It should be tucked beside the pattern to allow the gagers to be placed near the pattern. The cope is then placed on and an upset placed over the brackets to give sufficient depth of sand above the pattern. The gagers are set in the cope. They should be long enough to reach nearly to the top of the flask and have a heel about 6 in. long. The gagers will be most effective when placed in the division having the heel extending parallel to the pattern and as close as possible to the pattern. When pointed toward

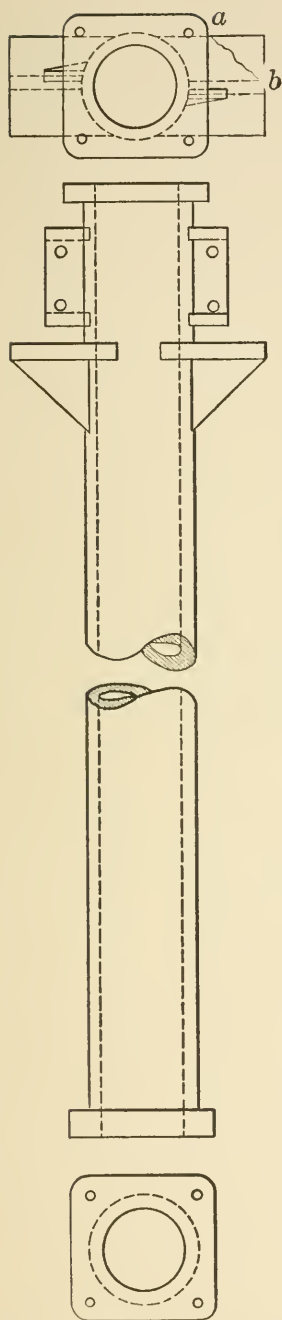

FIG. 43.

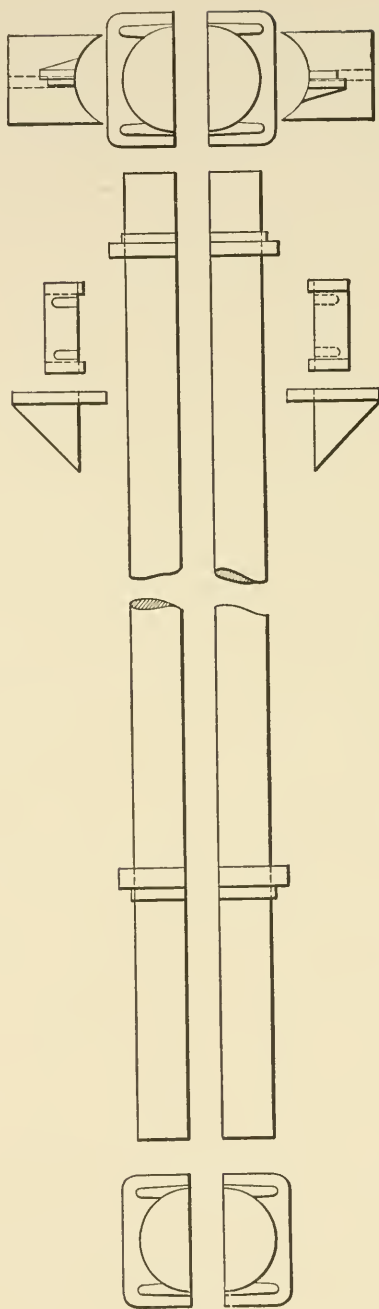

FIG. 44.

the pattern the edge is liable to break between the gaggers. It is only necessary to ram the cope one bar back of the collar. The gate is placed in this division and above the pattern. A riser should be placed above the large bracket. When the column has metal so thin that the iron is liable to be too cold when it reaches the bracket, it is preferable to have a gate at that end and pour with a bull ladle, thus supplying hot iron for the brackets. The cope should be rammed to an even hardness the same as that of the drag and should be well vented. The bracket must be anchored as strongly as possible, having a gagger come between the bracket and the beam connection to prevent the metal from breaking through. The ramming around the bracket should be lighter than on the main body of the pattern. The pressure of the metal is not sufficient to prevent scabbing or blowing as in the other parts. The pattern should be held firmly to the cope by wood screws while the cope is being lifted off.

In finishing the drag, it should first be vented by running the wire under the pattern from the sides of the flask and leading these vents off at the parting. Nails should be put in the corners near the collars and the brackets. The joint may be wet with the swab, then the pattern drawn. The brackets still remain in the drag. A large nail should be placed in each corner of the bracket and two placed between the bracket and beam connection to prevent breaking through, as the metal fills one before entering the other. The brackets are drawn and the mold slicked. The cores shown at B, Fig. 45, are set in the collars and those at A are placed in the beam connections. These cores must be anchored to prevent lifting, due to the

buoyancy of the metal. These cores may be held by nails so placed as to resist an upward pressure. The end stop-off core shown at C is placed at the outer edge of the collars. This core is the same thickness as the metal of the desired column. The chaplets are set in the drag. The number of chaplets depends upon the weight and length of the centre core. The centre core is placed in position and the end stop-off cores are placed on the top side. These small cores should be fastened so that they will not be pressed forward while ramming up the ends or be washed in by the iron. The gate comes through the end stop-off, hence it

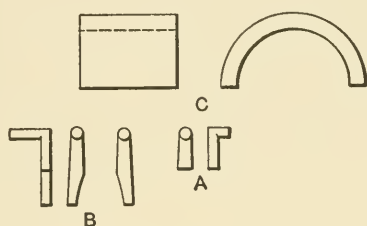

FIG. 45.

must be cut away back to where the metal enters from the cope and of a width to give the desired area of gate.

The cope should be finished similarly to the drag and the small cores set in the collars and the beam connection. The edges should be more firmly anchored than in the drag, so as to ensure holding when the flask is closed.

The cope chaplets are set and the flask may be closed.

In this form there is nothing to hold the metal from forcing the end cores out, hence there should be a division of the flask which may now be rammed with sand. The vents for the centre cores must be led off through the portion thus rammed.

The pouring basin may be built and the riser raised to the level with it. The flask is clamped and chaplets properly wedged, thus it is ready to receive the metal.

The strength of facing and the amount which may be used is entirely dependent upon the thickness of the metal and the length of the column. Generally, when the metal is 1 in. in thickness, facing of a strength of from 1-10 to 1-16 should be used all over the pattern. Small columns up to 9 in. in diameter having metal less than 1 in. in thickness should not be covered all over with facing except when short.

A column of 9-in. diameter and $\frac{3}{4}$ -in. metal, 18 ft. long may be made with facing 1-16 covering one-half its length. With facing stronger or covering more of the pattern, the iron is so cold before reaching the opposite end that it causes cold-shots, or it will not run full.

The manner of gating a column is dependent upon the size of the column. For small and thin columns, a single gate at the end supplies the metal fast enough and enables forcing in case the metal is somewhat cold. In larger sizes, as from 10 in. up, or 9 in. having thick metal, a gate on each side is more desirable. The metal may be led in by the end core or at the side by a runner and several gates.

In making cast **gears**, it is very important to maintain the exact form of the pattern and form all the teeth perfectly. The teeth are the most important part of such a casting, for if some are out of shape it will not run with the gear meshing into it, hence the casting cannot be used.

The sand must be rammed into the teeth uniformly, and that as soft as will resist the pressure of the metal. In small gears it can be done best by riddling the sand out-

side and throwing it into the teeth until all are covered, then ramming up the backing moderately hard. In large gears the sand should be nailed or rodded while being rammed and care should be used to ram the teeth to an even hardness.

When a gear is so small that facing cannot be used, mix new sand with the old in a proportion of 1 part new sand to 3 parts old sand and use it for the facing. In all other gears use facing varying in strength according to size. Generally use facing of strength of 1 part sea coal to 12 parts sand. Never use plumbago or blacking on the teeth unless they are of large enough size to smooth it on with a brush or slick. The loose dust only roughens the casting and causes a dirty, uneven surface.

The teeth of a gear cannot be patched with tools as can corners and surfaces of a common mold. The form of the tooth must be true, hence it is important that the pattern draw out well, leaving the teeth without tearing. Some patterns have the teeth dovetailed into the body, then if any tooth does not leave the mold well it may be pressed down and drawn out separately. With other patterns, in case of patching being necessary, the pattern must be replaced and the tooth re-formed.

The gate must always be placed upon the centre of a gear, as the teeth would be very liable to wash if the metal entered the mold from the rim.

The method of procedure in making a gear from a solid pattern may be shown in making a mold for the bevel gear shown in Fig. 46. The parting comes at the top or outer diameter of the teeth and at the bottom of the hub at the short side of the arms. If a special follow-board or match

is made for the pattern, the drag may be placed and rammed. In other cases, a match must be made on the cope. The cope is laid on a sand bed with the pins upward. Sand is filled in and rammed to a height that brings the parting line of the teeth even with that of the flask when the pattern is in position. The sand is rammed around the pattern until the level of the parting is reached. The parting between the arms is more easily made from this side than after the pattern is reversed; so this portion

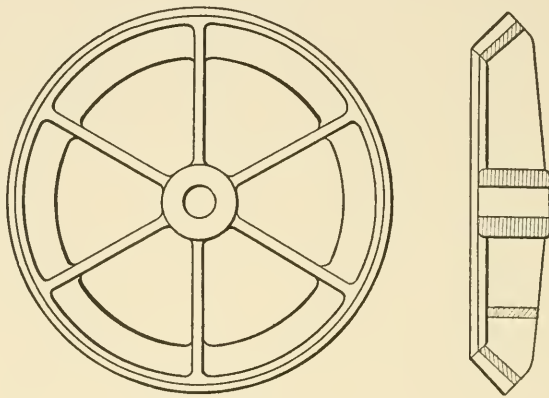

FIG. 46.

of the parting is made and parting sand put upon it. The drag is placed upon the cope, facing sand is thrown into the teeth until they are well covered, sand is riddled over this, and the remainder is filled and rammed. The drag is vented, care being used not to strike the teeth of the pattern. The whole is turned over and the cope lifted while the pattern is held into the drag. The parting at the outside of the pattern is first made and the sand removed from the centre down to the pattern. The pattern and adjacent sand are marked at some point by which to replace

the pattern after it has been removed. The pattern is rapped to loosen the sand in the teeth, then drawn, carrying with it the sand above the parting previously made. The pattern is brushed clean and replaced, which completes the parting of the drag. Facing is riddled over the face of the drag and the cope is replaced. Soldiers are placed to anchor the sand between the arms. These should extend to the top of the cope to ensure sufficient strength to hold the sand firmly when the pattern has been removed. The gate stick is placed on the hub beside the core print. Facing is filled in to cover the pattern and rammed between the arms with a hand rammer or rod that will tighten the sand evenly around the soldiers. The remainder of the cope is filled and rammed, care being used to ram around the soldiers without striking them. The cope is well vented and the gate stick removed without reaming or enlarging the hole, so that it may be replaced after the flask is closed. A wood screw or draw-spike is placed in the hub through the gate. This is held and slightly rapped as the cope is lifted off. The rapping frees the teeth and the pattern is held firmly in the cope by lifting on the screw. The sand around the pattern and between the arms is patched and nailed where necessary. In large patterns the sand should be nailed before drawing the pattern, to prevent the sand from loosening or dropping while closing the mold. The sand at the edges of the pattern is moistened with the swab and the pattern drawn. In case any of the teeth were torn or damaged when the cope was lifted, the pattern should be replaced on the drag and the tooth re-formed by ramming in sand with a small rod or nail. The pattern, then drawn, should give a per-

fect set of teeth as desired. Blacking may be put upon the cope and slicked, but it is preferable to leave the drag without blackening. The centre core is vented off at the bottom and has its top vent closed with sand so the iron cannot flow into it. The flask is closed and the gate stick replaced. A basin is built about it, as shown in Fig. 35, so that the metal will not be poured directly into the gate, giving the additional strain due to the metal dropping from the ladle.

CHAPTER II

DRY SAND MOLDING

Dry sand molds are made similarly to green sand mold, using special facings. The mold is blackened with a wet blacking and slicked smooth, then dried in an oven or by special drying apparatus. The surface after drying is hard, similar to a brick. This gives a surface that can withstand great pressures where a high head is necessary in casting. The dry face coated with the blacking prevents fusion of the sand and thus gives a smooth casting. Hence where it is desirable to have a smooth casting, or when the head pressure is great; dry sand or loam molds are used.

The mixture used next to the pattern in dry sand work is called the **dry sand facing**. That used to fill in between the facing and the flask is called the **backing sand**. Old molding sand forms a good backing. Dry sand facing comprises a mixture which will become hard and strong when dried and still be open to allow free escape of the gases. The mixture for the dry sand facing is dependent upon the sand obtainable in the locality. A sand too strong with clay gives the hard, strong face to the mold but will not allow the gases to escape. Where the molding sand is of a fine quality and quite strong with clay, Receipts Nos. 1 and 2 will make a good facing. The propor-

tion of sharp or lake sand may be varied where the facing is found to be too close or too open.

Receipt No. 1. Mix 1 part new molding sand, 1 part old molding sand, and 2 parts sharp or core sand. To 30 parts of sand add 1 part flour and 1 part sea coal. Wet with water.

Receipt No. 2. Mix 4 parts of molding sand with 1 part sharp or lake sand. To 30 parts of sand add 1 part of flour. Wet with clay wash.

Receipt No. 3. Mix 1 part of molding sand with 1 part of bank sand. To 30 parts of sand add $1\frac{1}{2}$ parts of sea coal and 1 part of flour. Wet with clay wash.

Dry sand may be **rammed** much harder than green sand. The facings are more open and the moisture is evaporated from it before casting. The ramming should be even, because unevenness may cause trouble similar to green sand though not so readily. Hard spots in the face of a dry sand mold will cause a scab on the casting.

The importance of **venting** dry sand must not be underestimated. After the mold is dried there is no moisture to form steam, as in the green sand mold. The other gases are still formed at the face of the casting and must be carried away or the casting is liable to blow or scab. When there is six inches, or more, of sand between the casting and the flask no venting is necessary. When less than six inches there is not sufficient space to relieve the pressure unless there are holes in the flask for release or vents for carrying off the gases.

As the body of sand increases, the pressure of the gases decreases, hence the smaller the body of sand the greater the necessity of vents. Large bodies of sand give relief to

the pressure through its openings or porosity. It literally holds the gases without increasing the pressure to a dangerous degree. Pockets, corners, flanges, and similar projections require venting and provision for conducting off the gases, but not so extensive as in green sand molds.

In green sand, when the joint comes together closely, it may compress slightly without damage when the flask is clamped. In dry sand, the hard surface will not admit of any compression without breaking away. This is avoided by cutting away the joint slightly at the edge of the pattern before or after drawing. This leaves a **fin** on the casting which may be chipped off. The edges where cores bear should be similarly treated. This fin should be from $\frac{1}{8}$ in. to $\frac{1}{4}$ in. in thickness and should slope back about 3 in. The maxim "It is better to have a fin than a crush" should be remembered in dry sand work.

The **finishing** of dry sand molds gives the face which causes the casting to peel. After the pattern is removed the face of the mold is dampened with molasses water or beer wash. This makes the facing stick together firmly and gives a smooth compact surface when slicked. The flour in the facing makes it rather pasty so it can be shaped more easily than a green sand mold. The entire face is slicked with the tools before blackening. Any part torn by the pattern may be patched similarly to a green sand mold. The face of the mold may be slicked much harder than in a green sand mold. The sand is much more open and held together by the flour so it will not scab so easily as green sand.

The **blackening** is put upon the dry sand mold to close the pores of the sand and give a smooth surface that will peel

from the casting. The **mixtures** given below have yielded very good results. The proportions may be varied to suit the qualities of the ingredients and to give better results in particular cases. When the blacking cracks or peels upon drying, the body has been put on too heavy or there is too great a percentage of clay wash.

Receipt No. 1 is used for light castings or where the thickness of metal is less than two inches. Receipt No. 2 is better for heavy or thick castings. Receipt No. 3 is a very simple mixture which gives good results on small or thin castings.

Receipt No. 1.—Mix 1 part charcoal blacking, 1 part Lehigh blacking, 2 parts plumbago. Wet with molasses water or sour beer.

Receipt No. 2.—Mix 8 parts charcoal blacking, 8 parts plumbago, 1 part thick clay wash. Wet with sour beer and allow to stand 2 or 3 days before using.

Receipt No. 3.—Mix a clay wash from red clay of a thickness that will color the hand when dipped into it. Add plumbago until it becomes of the thickness desired.

The molds are **dried** by heating sufficiently to drive off the water from the sand. This is accomplished in many different ways to suit the conditions. The best method is to dry the mold in an oven. The oven for this purpose is similar to the core ovens which admit a core car. The molds are put on the car for placing in the oven. The temperature is kept between 500° and 600° F. This will not burn the face of the mold and dries it very rapidly.

Some molds are dried by **injecting hot air**. The mold is closed with the pipe from a heater projecting into it. All the openings and the parting are sealed with clay to

resist the air pressure. The air is kept under a small pressure which forces it out through the sand and vents. The heat dries the sand, giving the desired result. One form of apparatus to accomplish this would consist of a heater or large stove having a coil of pipe in the place of the lining. The air is forced through this by a root blower. The blower is driven by a motor or belted from a shaft. The coil in the heater is connected to the mold by a pipe. The heater should be as close to the mold as convenient to reduce the cooling of the air before reaching the mold.

Another common method of drying is to use the **fire pot**. A charcoal fire is built in a fire pot and lowered into the mold. It should be kept at equal distances on all sides from the faces to be dried. The fire pot should conform to the general shape of the mold. This gives unequal drying on an irregular-shaped mold. When carefully followed very satisfactory results are obtained.

The face of the parting was slicked down before drying, so that the sand does not touch when the flask is closed. It is therefore necessary to place upon the face of the parting something that will seal this opening and hold the metal. A stiff dough made of flour and water, then rolled out into long strings, serves the purpose. The dough will flatten without damage to the mold, when the two parts of the mold come very near together: These strings, often called **noodles**, are placed around the edge of the mold and over cores which should bear on the cope.

Dry sand may be employed **without the use of facing**. It is claimed by many of the best foundrymen that it is unnecessary to use flour and sea coal in the facing for a dry sand mold where a good blacking is used. The object

of the flour is to make the face hard when dry, as a core. The sea coal is to prevent fusion of the sand and to peel the casting. For the medium-sized casting in dry sand, the facing used is 1 part new molding sand with 1 part old molding sand wet with clay wash and riddled through a No. 6 riddle. The backing may be of the coarsest heap sand. The blacking for the mold is made from Receipt No. 3. Castings made by this method have been found to peel and to leave as smooth and bright a surface as any dry sand mold.

In many cases where previously dry sand molds were used, it is found as satisfactory to only **skin-dry** the mold. The mold is handled in the same manner as a dry sand mold, but the drying is continued only long enough to dry the sand for a depth of about two inches.

Some kinds of sand which are quite strong with clay do not require the flour used in the dry sand facing, but hold well when moistened with clay wash, molasses water, or beer wash. Generally the same facing is used as in dry sand molds.

A skin-dried mold has the hard surface but the backing is still soft. This increases the danger of crushing when closed and of the cutting of the metal when poured. The mold should be cut away at the parting and the entire joint slicked down slightly to ensure the bearing on the flask instead of on the sand. The dried crust will separate from the green backing much more easily than a dried mold would break. When a casting is so gated that it would be liable to cut if the sand were green, it should be well nailed in front of the gate before skin-drying.

The face of the mold is finished, blackened, and slicked

the same as in dry sand. The blacking may be put on dry, then moistened with molasses water; or, better, the wet blacking mixture may be used.

A mold is skin-dried by the same method used for dry sand molds. For slightly drying the face of small molds, gasoline may be sprayed on the surface and burned off, giving a hard face. This may be used with some kinds of sand in the common green sand mold, giving the casting the appearance of coming from a dry sand mold. It gives a smoother casting in small work than the wet face.

Many castings cannot be easily made in a flask, owing to their size or form. These are made into the floor with a cope to cover a part or the whole. This division of molding is called **pit molding**. Fly wheels, large sheaves, and large gears are made in this way more easily than in the drag of a flask. Many large castings that might otherwise be made in a flask are bedded into the pit when there is no flask at hand. It is much cheaper to bed the pattern into the floor than it would be to make a flask when only one casting is desired. Some molds are subjected to an intense down and side pressure when the metal is poured. It would require a very strong flask to withstand this stress, hence it would be very expensive. If placed in the pit, the sand is rammed hard to the adjoining ground, hence the pressure is resisted except that on the cope, which must be provided for by weights, or the cope must be bolted to anchors in the ground.

Since there is no opening at the bottom, as in the case of a flask, for the escape of the gases, provision must be made to carry these off from the bottom of the mold. Below the mold at a depth of about 2 ft., a layer of coke or cinders is

placed to collect the gases. This **coke bed** is connected to the surface by a vent pipe. All the vents from the lower portion of the mold extend through to this coke bed, which gives relief to the gases.

To make the coke bed the pit is dug out about $1\frac{1}{2}$ or 2 ft. deeper than the mold would require. It is then leveled off and a layer of coke of about the size of an egg is put in to a thickness of 4 or 8 in. The coke is covered with hay, straw, or burlap to keep the sand from packing solid around the coke. A pipe of ample size to give free vent to the bed is placed at the outside to connect with the surface. The lower end of the pipe rests on the coke and is so covered with coke that the sand cannot enter the pipe. The sand may now be filled in to form the mold above.

Making castings by use of **sweeps**, in the place of patterns, is being extensively practiced where but a single casting is required. The time required for making such a mold is greater than that required where a pattern is used, but the expense of making the pattern is saved, except for forming the sweeps, which is very slight.

A simple form of the necessary rigging is illustrated in Fig. 47. The socket A is a cast base having a tapered hole in the centre for holding the spindle. The spindle B is made of steel or cast iron, and is uniform in diameter, having its lower end tapered to fit the socket. A collar is fitted to the spindle and has a set screw for fastening it at any point. This carries the sweep arm at the desired height. The revolving arm D is made of cast iron, bored to fit the spindle and having slots for bolting the sweep and allowing adjustment. The sweep is made of wood having the special shape for the desired casting.

The process of forming a green sand mold by use of a sweep may be noted in making a cover, as shown in Fig. 48. A hole is dug into the floor and the socket is bedded in so as to hold the spindle plumb. A coke bed is formed around it with the vent pipes leading to the surface. Sand

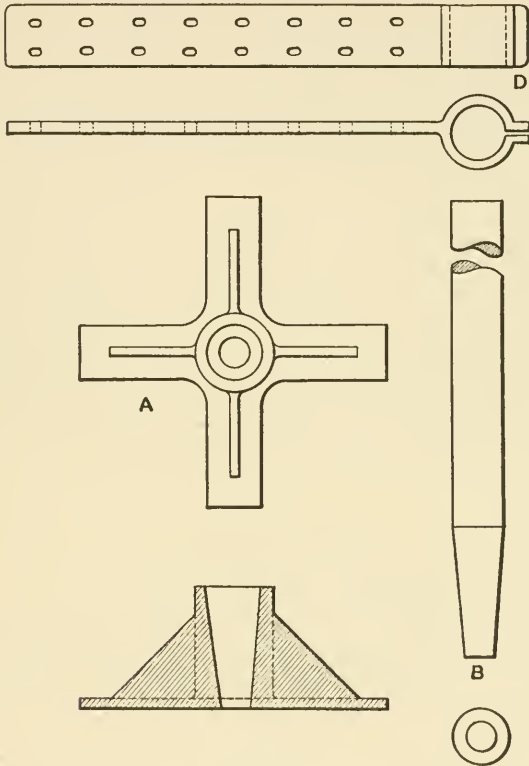

FIG. 47.

is filled in and rammed to a level shown by line MN, Fig. 49. This is well vented to the coke bed with a $\frac{3}{8}$ in. wire. Facing sand is filled in and rammed to the height that it is to be struck off and to approximately conform to the line ACB of the top of the cover. The sweep arm is placed upon the spindle above the collar C. The sweep is made

to conform exactly to the upper face of the cover. It is fastened to the arm so as to have the outer end at A strike

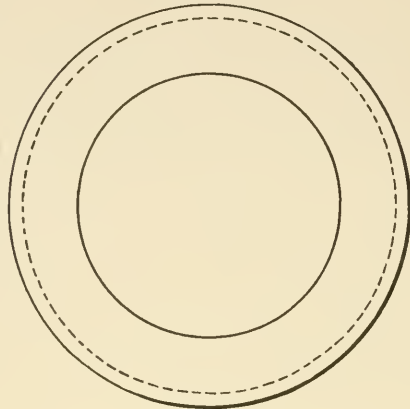
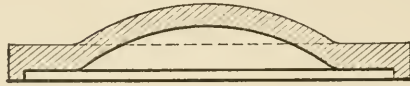

FIG. 48.

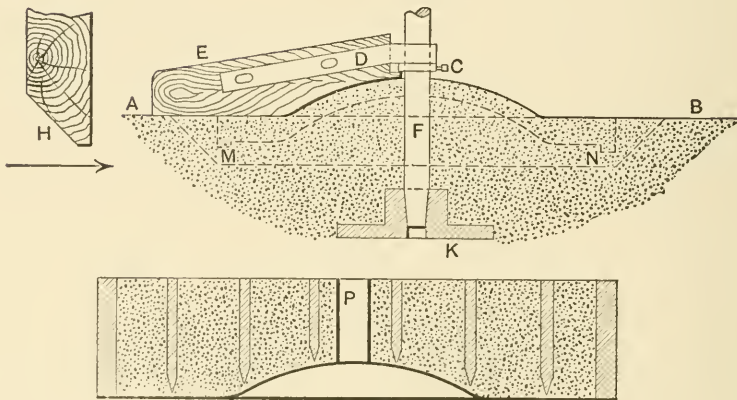

FIG. 49.

a level face, which gives the guide for the location of the sweep to be used later. The collar is adjusted to give the outer edge of the cover at the floor line. The surface ACB

is swept by revolving the sweep away from the cutting edge, as indicated at H.

The sweep and collar are removed and the surface slicked for a parting surface as usual. Parting sand is then put upon the surface and a cope placed in position and staked at the corners to allow replacing after removing for finishing the mold. A short pipe or box is placed around the spindle to allow lifting the cope, as at P, Fig. 49. The cope is rammed as usual with the necessary gates and risers. The cope is lifted off, finished and

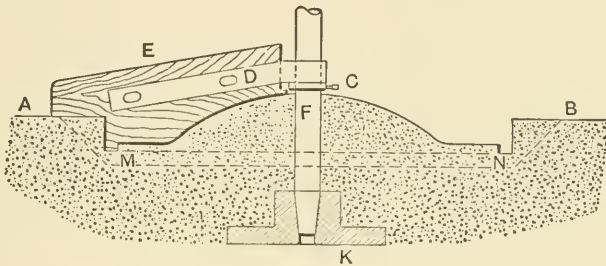

FIG. 50.

blackened. The pipe at the centre is drawn back and filled, then faced to the desired surface of the cope, care being used to properly vent it. A second sweep, E, Fig. 50, is placed upon the spindle which exactly conforms to the under side of the cover, having the edge A as a gauge for the depth and following the level surface previously swept. The collar on the spindle is adjusted so that the level face of the sweep just touches the level face previously swept, then the drag is swept out to the desired shape. The sweep and spindle are now removed and the face of the mold finished. The opening left by the spindle is filled with cinders nearly to the surface, then facing sand is

rammed in until the desired face is reached. The drag is finished and blackened, with the gates and risers properly connected to the mold. The cope may be replaced by aid of the stakes, which completes the mold as shown in Fig. 51.

Methods of casting fly wheels are various. Fly wheels are made from part patterns which are moved about a centre spindle. The arms are made in core, while the rim may be in green sand, core sand or loam. The method of procedure in making a mold for a fly wheel will be given

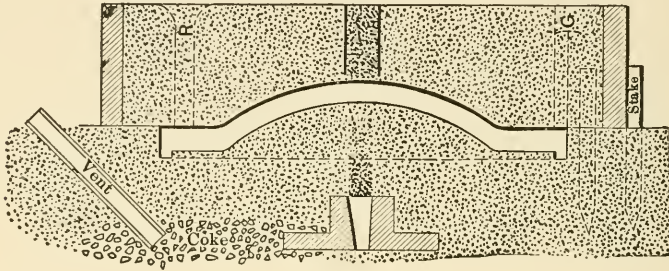

FIG. 51.

in a general way, for the details cannot be understood until the actual experience has been met with.

The coke bed is made under the rim to extend inside part way. The socket for the spindle is set in the centre and below the hub cores. This socket is so leveled that the spindle stands exactly plumb.

The bottom core for the hub is located about the spindle. A sweep, so shaped as to form a bed for the arm cores of the wheel, is then placed on the spindle. This sweep has its lower edge shaped like the strike stick previously mentioned.

The bed is rammed and struck off with the sweep over

the entire portion within the rim of the wheel. This gives a bed such that when the arm cores are laid upon it the centre line of the arm is level.

The arm cores are so placed upon the bed that their outer ends just touch the inner face of the pattern for the rim. This is gauged by fastening a vertical piece onto the sweep previously used at the same radius as the inner portion of the pattern. The collar on the spindle is fastened so as to support the sweep above the cores. The cores are placed so the vertical piece on the sweep will just clear the end, thus giving the desired radius.

The pattern is placed upon the spindle and the rim is rammed, a section at a time. Each time the pattern is moved it is kept at an exact level, thus when the last section is made the pattern strikes exactly where it started. With wheels having a straight rim without flanges, both faces may be rammed in green sand. Where there is a flange at both edges, various methods are used. When the rim is light and the face less than 14 in., the lower flange may be made by cores laid while ramming the mold, and the outer face rammed at the same time. When large it is preferable to make the outer face in core or loam. The pattern then has a core print below the face and one above it and the green sand is rammed only on the inside of the rim. The cores for the face bear on the green sand above and below the casting and extend to the inner face of the flange. These cores are held in place by ramming the sand solid back of the cores, bringing the floor level with the top of the core. The cores may also be held by binding plates and supports to hold the outward pressure on the rim when the mold is poured. When the outer face

is made of green sand, the top is covered with cores, then weighted down to hold the pressure.

The gates are placed on the hub with a runner and pouring basin leading to the outside of the rim, where it is accessible to the ladle. Risers are placed on the rim and the casting fed through the gates and the risers, when the rim is heavy enough to require feeding.

Loam is used to make large molds of the same type as dry sand. Loam can be easily shaped by use of a sweep, and when dried will resist great pressures and will give a casting with smooth surface the same as dry sand. Loam is chiefly used where the whole or a part is made with a sweep.

Loam must be of a very open texture, so that in general the mold requires but little **venting**. Corners, pockets, projections, and parts not having free relief to the gases are safer when vented and these vents led to the outside. Hard-burned brick should never be used for the face of the mold, as it prevents the escape of the gases. The courses of brick are occasionally separated by a layer of straw to give better venting.

The body portion of a loam mold is made of **bricks**. This conforms approximately to the pattern or desired face of the mold. The bricks are laid up in courses so as to break joints and to bind the whole firmly together. They are laid in a coarse, open mixture of loam to aid the escape of gases. The bricks must be of a soft porous kind. In some cases bricks are made from loam for forming portions of the brick wall. These are more porous and crush more easily than common bricks when the casting shrinks. They are made from a stiff mixture of coarse loam just

soft enough to work easily. The bricks are made in the box and laid on a plate whose face has been oiled, and are then dried in the oven.

The bricks are given a first coat of coarse, open loam, swept to shape, and a second or finishing coat of loam which is finer and thinner. The thickness should never be less than $\frac{3}{8}$ in. to $\frac{3}{4}$ in. for plane surfaces, and not less than 1 in. in pockets, projections, etc. The thickness of the metal does not gauge the thickness of the loam, because a heavy casting will scab as quickly as a thin one. The thicker the loam, the better the venting.

The **loam mixture** is more of a mud than that of green or dry sand. It contains much clay combined with sharp sand and other materials to make it open. The exact mixture is entirely dependent upon the sand used. In a few places the natural loam is found which may be used without any additions. The mixture must contain enough clay to hold the sand together. If the mixture is too weak with clay, it will crumble when compressed in the hand. When too strong, an experienced mechanic can tell by the feeling, but no easy method can be pointed out. When the mixture is too weak the face of the mold will crack or crumble easily. When too strong or close the casting will scab, as the iron will not lie quiet against it. The percentage of clay determines its condition. The mixture giving the best results can only be told when the sands to be used are known. Several mixtures are given below which give good results at different places, using the sands available at the particular place. These may be taken as general guides and varied to suit the sands used. The clay wash generally consists of 6 to 8 parts

of clay to 1 of flour, wet with water to the desired consistency.

Receipt No. 1.—4 parts loam sand, 1 or 2 parts sharp sand, 1 part dried horse manure. Wet with medium thick clay wash.

Receipt No. 2.—4 parts molding sand, 5 part sharp sand, 1½ parts dried horse manure, ½ part dried and sifted fire clay, ½ part sea coal. Wet with fair clay wash.

Receipt No. 3.—3 parts fire sand, 2 parts molding sand, 1 to 10 parts horse manure. Wet with thick clay wash.

Receipt No. 4.—4 parts fire sand, 1 part molding sand, 1 part dry riddled fire clay, 1 part white pine sawdust. Wet with thin clay wash.

Receipt No. 5.—2 parts loam sand, 2 parts sharp sand, 1 part old burned loam sand, 1 part horse manure. Wet with thin clay wash.

CHAPTER III

MOLDING SAND, MOLDERS' TOOLS, MACHINES, AND EQUIPMENT

A **sand** suitable for **molding** must be open to allow the escape of gases and must be able to hold a given form to withstand pressure and wash of the metal. Such a sand has a percentage of clay, or binding material, which will hold the mass together firmly when dampened and compressed. If the percentage of clay becomes too great, the sand is too close when compressed, so the gases cannot pass off; then the metal will not lie quietly against the face of the sand.

The molding sands used in different parts of the country vary greatly in their composition. Those high in clay must be used with as little water as possible and must not be compressed or rammed much, as the mold must give free escape for gases through the sand. The coarse sands very low in clay may require much water and hard ramming in order to form a satisfactory mold. The tempering and ramming of the sand must be largely gauged by the nature of the sand the molder has at hand.

Tempering the sand means the mixing and wetting of the sand ready for making a mold. It is otherwise known as **cutting over the sand**.

The sand should be mixed evenly and to a dampness such that it will stick together when squeezed in the hand, but not so wet as to show moisture or dampen the hand. The sand pile should be opened out so that there will be no holes in which the water will accumulate. The water should then be thrown over the sand in thin sheets by swinging the pail with the bottom slightly ahead of the top. In this manner the water is distributed evenly and does not cause mud in spots. If the sand is wet excessively in spots, as by throwing the water on the pile in a body, it requires much more shoveling to obtain an even temper, hence loss of time. The sand should then be shoveled over in order to mix thoroughly. The shoveling should be done so as to scatter the sand when casting it from the shovel. This is accomplished by giving the handle of the shovel a twist just as the sand is leaving it. When wishing to throw the sand to a distant point, it should be allowed to leave the shovel in a solid mass, but this does not mix it evenly. In mixing, a space should always be kept between the pile from which the sand is taken and the one to which it is thrown. If this is not observed some of the sand will not be thoroughly mixed. After the sand has been shoveled over once it is seldom found to be mixed thoroughly, which makes it preferable to cut it over from two to three times. All the water necessary for the proper tempering should be put on before shoveling over the sand the last time. When trying to find whether the sand needs more water or not, the hand should be forced into the pile to get some sand from the interior from which to determine its temper. This should be done at several points. When only a little more water is necessary it should be

sprinkled on by throwing the water from the pail with the hand.

The molder or helper should learn to shovel both right- and left-handed, so as to be able to take either side of the heap when working with an assistant.

The **riddle** is the sieve used for sifting the sand. Its meshes range from 2 to the inch to 16 or 32 per inch. They are numbered according to the number of meshes per inch, as a No. 2 riddle means one having $\frac{1}{2}$ in. meshes, a No. 4 has $\frac{1}{4}$ in. meshes, a No. 16 has $\frac{1}{16}$ in. meshes, etc. In some places the riddles having the mesh finer than $\frac{1}{8}$ in. are called sieves.

In **riddling sand** by hand, the riddle should be held loosely in the hand and carried by the fingers, so that the palm of the hand will strike the rim as it is cast from side to side. Hitting the rim of the riddle in this way jars loose the sand that sticks to the riddle, keeps the meshes open better, and allows the sand to pass through more freely. By practice in holding the riddle in this manner, a rocking swing may be obtained which jars the riddle at each turn and carries but very little weight on the fingers. It is often found of advantage, especially in fine riddles, to put some irons in with the sand, as gagers, etc. These irons scrape the wires clean and add to the jarring of the riddle.

When not in use, the riddle should always be hung up on a nail or placed on the sand heap with the screen up. If left with the screen resting on the sand, the meshes become clogged, thus hindering the passage of the sand through the screen.

There are many forms of mechanical sand sifters. The

two representative forms of pneumatic sifters are shown in Figs. 92 and 94, while the belt-driven sifters are shown in Figs. 99 and 100.

Facing sand is placed next to the pattern in making a mold in order that the sand will **peel**, or part, from the casting freely and leave a smooth surface. Facing sand contains a percentage of sea coal and usually new sand, dependent upon the kind of work for which it is to be used.

The percentage of sea coal varies greatly, depending upon the thickness of metal and type of casting. The limits are 1 part of sea coal to 2 parts of sand, and 1 part of sea coal to 16 to 20 parts of sand. The limiting proportions are very seldom used. The usual proportions are from 1 to 6, to 1 to 14 of sand, depending on the thickness of the metal. When the metal is thinner than $\frac{1}{2}$ in. no facing is necessary. Better and smoother castings are obtained in this case by using heap sand riddled through a fine riddle onto the pattern. For metal between $\frac{1}{2}$ in. and 1 in. the proportion should be about 1 part of sea coal to 12 or 14 parts of sand; between 1 in. and 2 in., 1 part of sea coal to 8 or 10 parts of sand; above 2 in., 1 part of sea coal to 6 or 8 parts of sand.

The sand used in the facing may also vary in its proportion of new and old sand. This is dependent upon the sand used. The most general proportion is 1 part of new sand to from 3 to 5 parts of old sand. Greater percentages of new sand may be used on heavy work. The limiting case is a facing made of entirely new sand for the cope of very heavy work.

It is not always the thickness of the casting that regulates the strength of the facing sand. There are many

other things to be considered: (1) whether the casting is to be poured with hot or dull iron; (2) the distance of some parts of the mold from the gate; (3) the time it will take the mold to become filled with iron; (4) whether the metal is running over flat surfaces, and (5) is covering them slowly or quickly. Then again, heavy solid castings have become "cold-shot" owing to the use of facings that were weak in proportion to the casting, caused by the slow rising of the metal in pouring. Strong facings on the sides of a mold, where the iron enters and rises slowly, may easily cause heavy castings to be "cold-shot." Again, the square corners of castings should, in general, have weaker facings than the straight, plain surfaces. The lower parts of deep molds should have a stronger facing than the upper portion, because the metal becomes dull while rising to the top of the mold. If the facing suitable for the lower portion were used at the upper, the casting at the upper part would become curly or partly cold-shot at the surface. A new sand without mixture will require more sea coal than if it were mixed with old or common heap sand.

A thorough mixing of the facing is necessary. If the sea coal is not evenly mixed, it often causes the casting to be streaked, veined, or cold-shot.

In mixing by hand it is almost impossible to distribute the sea coal evenly, therefore it is important that it should be handled several times in order to come as near as possible to a thorough mixture.

In mixing, the old and new sand should be kept as dry as possible when shoveled over in order to mix well. The sea coal is added while the sand is spread out thin. The whole is cut over once or twice, then riddled through a No.

6 or 8 riddle. It is then tramped down and water put on to give the proper temper, as in the case of tempering the heap sand. It is again cut over to mix the wet and dry sand, then riddled through a No. 4 riddle. It is now ready to be riddled onto the pattern. The mixture should always be riddled twice, and better still, three or four times. It is best to use sand quite dry to start the mixture, as when wet the sea coal sticks in small balls and does not mix well.

In large foundries, the facing sand is mixed by a facing machine which gives a mixture of exact proportions and more thoroughly mixed than can be done by hand.

The frame in which a mold is made is called a **flask**. It is composed of two or more parts. The bottom part is called the **drag** or **nowel**, the top part is called the **cope**, and the intermediate parts, when used, are called the **cheek**. Flasks are made of wood or iron.

The form of flask used for small patterns when the pressure of the metal is very little, is represented in Fig. 52. These are called **snap flasks**. They are hinged at one corner and fasten at the diagonal corner with a snap. The mold is rammed in the flask and when ready for pouring the flask is unsnapped and removed. Thus many molds may be made with a single flask. Before casting, a frame the same size as the flask is placed around the body of sand and a weight is placed on top to prevent straining the mold when under pressure.

Small flasks up to 14 in. square may best be made of iron, without bars in the cope. Those larger may be of either wood or iron to suit the style of work to be put in the flask. When the flask is for a special pattern and is to be used for that only, an iron flask will give the better service

and is far cheaper. When for general patterns, the wood flask has many advantages. The bars may be fitted to a pattern in wood with little time or expense, and for a class of small work up to 40 in. square, may be made of sufficient strength. Larger flasks are made of wood having bolts or iron bars for stiffening the cope. When but a single casting is desired, even to very large castings, the flask may

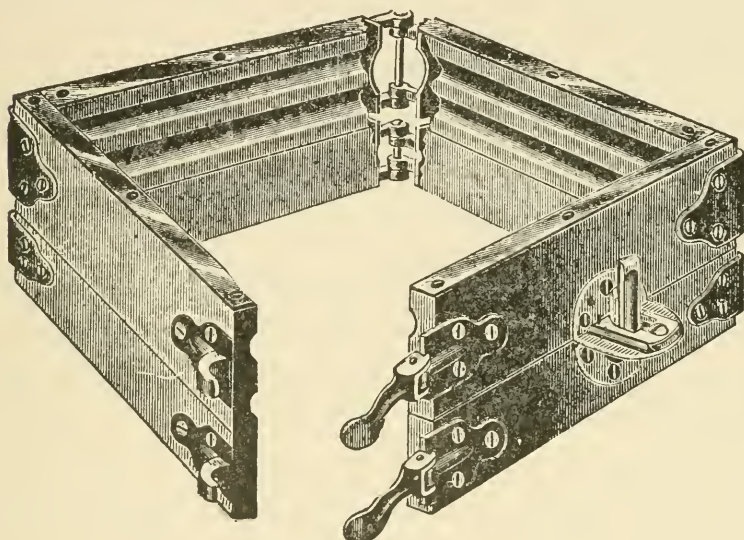

FIG. 52.

be more cheaply made with a wood frame and iron bars than entirely of iron.

In manufacturing shops having a fixed line of patterns, the iron flask is of great value. The first cost is more than that of a wood flask, but the durability far exceeds that of wood. The bars are shaped to suit the pattern, and they remain so; while a wood bar burns out and the joint of the wood flask burns away leaving holes which may cause a un-out, thus losing the casting. The iron flask is much

heavier to handle, but it may be fitted so as to require less anchoring in the sand, as gagers and soldiers which would be required in a wood flask; thus the time saved in molding will more than equal the extra help necessary to handle the flask. Large flasks to hold castings, as cylinders, engine girders, bed castings, etc., and flasks to be used many times, should be made of iron and well braced. They are then ready at all times and may be used without loss of time in repairs.

To point out the saving resulting from the use of a flask instead of bedding the pattern into the pit, the relative time required for making a girder casting in the two ways may be cited. Before the flask was made to hold the pattern, it was bedded into the pit with a cope to cover it. It required a time equivalent of 14 days for a molder and helper to complete and cast the mold. After the flask was made so the pattern was rammed in the drag and turned over, it required a time equivalent of 9 days for a molder and helper to make the same casting.

Molders' tools vary greatly with the general type of work that the molder is making. The number of tools necessary for a molder on a particular type of work may be three or four, while on intricate work many tools may be required. There are tool manufacturers who can furnish tools of nearly any size or shape that a molder may desire. The more common forms are shown in Fig. 53. These are used for nearly all classes of work and are made in many sizes as desired. No. 1 is a round point finishing trowel; No. 2, a square trowel; No. 3, a lifter for removing sand from deep and narrow parts of a mold; No. 4, a flange and bead tool for slicking special round surfaces;

Nos. 5 and 6 are two forms of **double-end slicks** which represent the general forms out of greatly varying forms of such tools; No. 5 has an **oval slick** at one end with the **spoon slick** at the other; No. 6 has the **square and heart slicks**; Nos. 7, 8 and 9 show **corner slicks** of which No. 7 is for round corners, No. 8 for square, and No. 9 for inside corners; Nos. 10 and 11 are **pipe slicks** for cylindrical

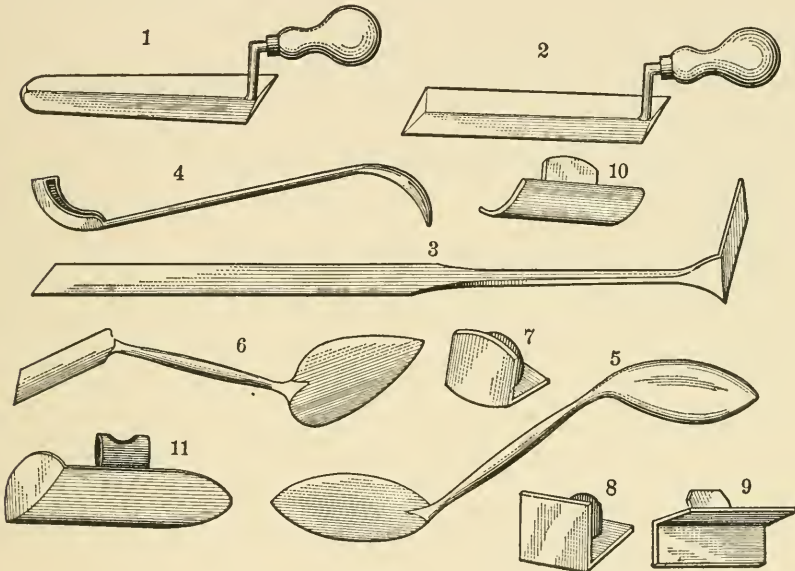

FIG. 53.

surfaces; No. 10 has the square ends, while No. 11 has the safe end for a corner slick.

The success of making the mold and obtaining a good casting is dependent mainly upon the manner of **ramming the sand** to form the mold. Hard spots in the sand cause scabs, and soft spots cause swells. Unevenness of ramming causes similar unevenness in the casting.

In ramming the drag, the flask should be filled to a

depth of from 5 to 6 inches, ramming first around the edge of the flask, then next to the pattern, and, lastly, the portion between, using the **pein**. On small castings, it is rarely necessary to ram the sand over the pattern. The **pein** or the **butt** of the rammer should never strike within an inch of the pattern, as it will cause a hard spot at that point.

In deep molds the succeeding rammings should be done by filling in loose sand to the depth of about 6 inches, and ramming first with the **pein** then with the **butt** in order to give the mold the proper degree of hardness.

In ramming the drag, either the **pein** or the **butt** may be used as soon as the pattern is well covered, so that the ramming is not near the pattern. It is of advantage to tramp the sand with the feet before butting, as that more quickly compresses it to a moderate hardness and facilitates the **butt** ramming.

In ramming the rim of a pulley, the rammer should be directed away from the pattern to prevent scabbing the rim.

The larger the pattern, the harder the sand may be rammed. When of a depth to give a great pressure on the bottom, the sand must be rammed harder to hold the pressure and prevent the cracking of the surface, causing roughness sometimes called "whiskers."

On patterns of the round column type, the sand may be rammed very much harder than in other cases, if the metal is to be thick. It is very important to have these rammed evenly, as unevenness will cause defects in the casting; even though it is not of a hardness at any point which would be detrimental were the entire mold of that hardness.

The softer the sand can be left and still hold the casting in proper form, the less is the liability of losing the casting. The sand must be hard enough to hold its shape, but after that the risk of loss in casting is increased as the hardness is increased.

In ramming the cope where there are no bars, the sand is filled in to a depth of about six inches and rammed around inside the flask, then the remaining portion is rammed evenly with the pein. The butt should not be used in the cope until the entire flask is filled, then the last ramming on top is done with the butt. If the butt is used before this it causes a hard surface, so that the sand does not unite in the succeeding ramming and is liable to fall out when the cope is turned over. When the cope has bars, each division enclosed by the bars is rammed separately as a small cope, but all the divisions must be of an even hardness. The successive rammings are made by filling in about six inches at a time and ramming with the pein.

The proper manner of holding the floor rammer while ramming is to grip the rod connecting the pein and butt with one hand above the other. Never hold the rammer with one hand on top of the upper end of the rammer, as it will jar the operator, and it is harder to do good ramming while in this position.

The proper **venting** of a mold is of as great importance as any part of the process. If at any point the venting is insufficient to carry off the gases, the metal will blow and spoil the casting.

The air in the mold, when the metal is being poured, must be able to escape. This is provided for in some

cases by the riser, but often the vents are depended upon for this purpose. The water in the sand is evaporated as steam and must escape through the sand. The continued addition of sea coal in the facing, and flour and plumbago in the mold, increases the formation of gases when the metal comes in contact with the face of the mold. If these cannot escape into the sand, they force an opening through the molten metal, which is known as blowing. To enable the gases to pass through the sand, the mold must be properly vented. Some sands are so coarse and open that they require much less venting than others which are fine and close in texture.

Small and thin castings, rammed lightly, require no venting. In casting heavy, thick plates the drag must be well vented, but the cope does not require much venting, although it is always best to vent it. In venting any plain casting, the size of vent wire is mainly dependent upon the depth of sand to be vented. For flasks up to 12 in. in depth, $\frac{1}{8}$ in. wire serves well. The exact size of wire used is unimportant, so that the venting is close enough to give free escape for the gases. The vent wire should not strike the pattern or scrape along a side, as it forms holes that the metal may flow through and allows the metal to stop up the vent, which gives the same condition as though there were no vent. The bottom board should be put on the drag and rubbed to a bearing, then removed, and the surface creased crosswise by striking with the corner of a stick to reach the width of the drag, then the drag vented. The creases form openings through which the gases may escape when the drag is turned over.

For small castings, the cope should be vented through

almost to the pattern to give free escape for the gases and air. For larger castings it is often advisable to leave a layer of two to three inches next to the pattern without vents. This does not give free escape for the air; thus a pressure can be maintained within the mold while pouring, which prevents the drawing down of the cope.

Many molds have enclosed bodies of sand which do not have free vent connections with the top or bottom of the flask, as anchors in pulley molds, centre parts in three-part flasks, or large green sand cores. The vent must be led to some convenient point where an opening is left through the cope for the gases to escape. A gutter may be cut around the surface of the body of sand about three or four inches from the pattern and connected to the vent opening. Slant vents from the gutter will give free vent to the gases.

In some molds there are pockets having metal on all sides but one. The vent must be led away through this side and this very freely. When the pocket is small, a vent rod may be laid in it, and slant vents leading to the pattern give the necessary relief. When the pocket is of large size, it is not safe to depend on the slanting vent. In these cases the gases are collected by a coke or cinder bed laid in the pocket and led to the outside by a vent pipe or large vent rod.

In some patterns, as columns, the vent may be led off at the parting instead of through the bottom of the drag. After the flask is rammed up and the cope removed, vents are made under the pattern from the surface of the drag at a distance of about two inches apart. These are led to the outside by cutting, or

scratching, a small gutter in the surface from the vent to the flask.

Pit molds and all floor molds must be provided with a cinder bed located about one and one half or two feet below the casting to provide for the escape of the gases of the lower half of the mold. The cinder bed is connected to the surface by vent pipes, which give free passage for the gases. Very deep molds may have cinder beds located at different levels around the mold. The gases are led to the cinder bed by freely venting the mold so that the wire strikes the bed.

Surface molds require much better venting than those covered with a cope, as the metal gives no pressure except its weight; thus it cannot force the gases against much resistance. Small surface molds may not require venting, if the sand is rammed only enough to prevent the metal cutting when poured. Large molds must be provided with a cinder bed which has free vent to the surface. The mold must be well vented to the bed.

When two parts of a flask are to be lifted apart after the sand is rammed, it is necessary to make the surface at the **parting** so that the two bodies of sand will not knit together but separate freely when the flask is opened. In order to ensure the parting, the surface of the sand must be slicked smooth after making the surface harder than the other part of the mold and covered with a parting sand.

When the drag is turned over and the follow board is removed, the surface is gone over with the hand and sand tucked in wherever soft spots are found. The sand is then cut away to the parting of the pattern or to the

surface of the part. A thin coat of sand is then riddled onto this surface and the whole slicked to a smooth face. The additional sand compacts the surface to a harder shell and should not be easily broken by the ramming of the sand that rests on this parting. This slicking must not be carried to an extent of causing an extra hard, or bricklike face, as this will cause defective castings similar to hard spots in ramming.

Parting sand is put over the surface in a thin coating. All parts of the sand must be covered, for any spots left bare will stick and not give a clean part. Parting sand used for this purpose may be any fine, dry, sharp sand, very fine cinders, or burnt core sand from the burned cores in the castings. This sand is most convenient on all plane surfaces and where the slope is not so great that it will not stay on the entire face. In cases where the dry sand will not cover the surface well, wet sharp sand makes a good part. The fine, sharp sand is dampened until the sand sticks together, then it is put onto the surface with the hand or slicked on with a tool. It often helps to dust a little dry parting sand over the wet sand after it is on the surface, as the wet sand sometimes sticks when the surfaces are lifted apart.

Parting sand and burnt core sand make molding sand coarse and weak, as it loses its strength to hold a form when rammed. Too much of the parting sand will spoil the sand for the mold.

Gates are the openings through which the metal enters the mold. The location of the gate makes a great difference in the resulting casting. A mechanic can show his ability in gating properly more readily than in any other

part of the mold. Many castings are lost just because the molder is not particular enough in locating and cutting his gates.

All plain castings having about an even thickness, and that greater than the runners, are gated at the side and present little or no difficulty. As thin plates having runners heavier than the casting set sooner than the runner, they cannot be gated at the side, because when the runner cools the casting will be strained or warped. A good form of gate in such cases is that known as the bridge gate, having a basin above which is connected to the mold by a long narrow opening through which the metal enters. This gate is easily broken off and leaves the casting straight.

On any casting having ribs running from the side to the bottom, the metal should be directed lengthwise of the rib, in preference to flowing over the edge of the sand, as there will be less danger of the metal cutting the sand.

The thin parts of a casting should be filled as quickly as possible after the metal starts into them. A casting having heavy and light parts should be gated so that the thin parts can be filled quickly, and not rise slowly, as when filling both the heavy and light parts at the same time. If the gate is placed on a thin part so that the metal flows over the surface of the mold into the heavy portion of the casting, the inflowing metal will become cooled, and as it rises into the thinner parts it is liable to become cold-shot or form seams, which spoils the casting.

The gate must be so located that the metal will not flow over a sharp bead of sand which may be washed

away. This difficulty is sometimes overcome by use of the horn gate.

The common use of a **riser** on small castings is to allow the air and gases to pass out of the mold while it is being poured. The dirt carried into the mold by the inflow of metal is carried on the surface of the iron, and, as the metal rises in the riser, the dirt is floated out of the casting.

On large castings or those whose shrinkage is great, the riser is made large so as to supply metal to feed the shrinkage. The riser must be large enough so that it will not freeze until the casting itself has set. If the shrinkage is not thus taken care of, the casting is liable to have shrink-holes in it.

The location of the riser for small castings is not of great importance, although it is best to have it where the dirt is most liable to accumulate. In castings where it acts as a feeder, it should be connected as near as possible to the heaviest part of the casting. In castings of such a size as to require feeding, the riser is placed over the heaviest part of the casting and it becomes a feeding head. In this case the casting is fed by a feeding rod, which keeps the riser from freezing until the casting sets. This process is called feeding, or churning, the casting. In some cases, as cannons or rolls which are cast on end, the casting is made longer than that desired and the end turned off in the lathe. The extra length takes the place of the feeding head and is known as a sinking head. In this case the casting does not require feeding.

Some foundries making castings only up to the me-

dium weight never make use of the feeding rod, but, instead, depend on the riser as a sinking head and pour the iron as dull as it can be run into the mold. These castings are often unsatisfactory and frequently have shrink-holes in their upper surface.

A **skim gate** is an arrangement of gates, risers, and runners leading to a mold, whereby a supply of pure metal may be obtained, and the impurities remain in the riser. An ordinary skim gate may be constructed,

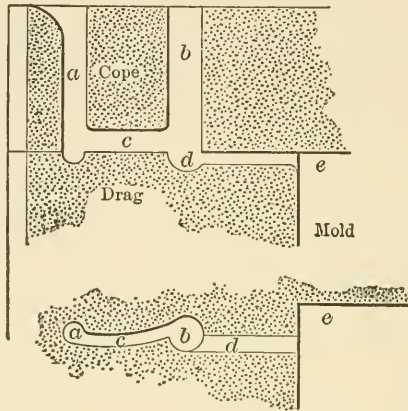

FIG. 54.

as in Fig. 54. The molten metal enters through the pouring gate *a* and flows through the runner *c* into the riser *b*. The impurities come to the top in the riser while the pure metal, being heavier, remains at the bottom and flows out through the runner *d* into the mold *e*. The arrangement of the gate, runner, and riser, as shown in the plan view, is for the purpose of giving the metal a rotary motion while rising in the riser *b*. This is intended to aid the separation of the impure metal, sand, and dirt from the pure metal. The runner *d* is below

the level of the runner *c*. The cross-section of *c* must be greater than that of *d* to ensure keeping the riser *b* full while the metal is being poured. Good results and sound castings are obtained by the use of this arrangement for the gate.

The top gate with the pouring basin, shown in Fig. 35, forms a good skimming gate. It is upon the principle that the pure metal being heavier flows into the mold from the bottom of the basin, while the impurities remain

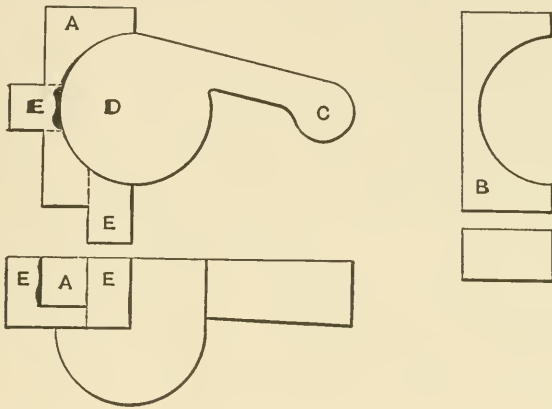

FIG. 55.

at the top. In pouring, the basin must be kept full so that the metal enters the gate from the bottom instead of from the surface of the metal in the basin. The only time when dirt can be carried into the mold is before the basin is full. The dirt is carried ahead of the metal.

The preceding arrangements are formed by the gate sticks, gate cutter, and trowel. A very convenient device for forming a skim gate is by use of a pattern, as shown in Fig. 55. This pattern is rammed up in the drag with the pattern to be molded. The portion marked

A is a core print. After drawing the pattern, the core B is placed in the prints. The metal entering at C is given a rotary motion under the riser placed at D where the impurities rise. The pure metal flows under the core into the mold through E.

There are few things in connection with making a mold that are of greater importance than the construction of the **pouring basin**, gate, runner, and riser. Skill is necessary to be thoroughly successful in their construction. In these, the washing or cutting away of the sand by the force of the falling metal is most likely to occur. When this takes place, great damage is likely to result to the casting. If the molder should slight any other portion of the mold, he may still get a casting which would pass inspection; but any neglect or ignorance in the construction of the pouring basin, gates, or runners will usually spoil the casting. When the sand in these cuts or breaks, the loose sand flows with the metal into the mold and causes a dirty casting. Great care should be taken to have the sand well tempered for the construction of a pouring basin. To make a reliable pouring basin, the sand should be rammed evenly into the box, or frame, and the basin cut out with the trowel. This ensures an even solidity to the sand and prevents cutting or washing.

Gaggers are L-shaped irons used by molders to anchor the sand into the flask. The lower end of the gagger is called the "heel," and varies in length from two to six inches, to suit different conditions. The other portion of the gagger may be of any length to suit the depth of flask in which it is used. Some gaggers are

made with a short hook bent at the upper end for hooking over the bar of the cope to ensure firmness in lifting. They are made either of wrought or cast iron. Wrought iron is preferable, for in some places it is necessary to bend the gagger to suit the particular conditions.

Gaggers are of great assistance in securing sand into a flask and in many cases are indispensable. To obtain a good lift in a cope without gaggers, requires the bars to be in very good condition and to come near to the parting. With gaggers, the sand may be anchored without the bars being new for each special casting.

The strength with which the gaggers hold the sand depends upon the manner in which they are set. When properly set they hold with great efficiency. When set wrongly, they only add weight tending to pull the sand down or cause a drop-out.

The gagger should be so placed that the heel comes near to the parting of the sand to be lifted and should be parallel to it. The length of the gagger should come against the bar or frame of the flask, as shown at A in Fig. 17. It is not always necessary to have the gagger stand vertical, although that is the best position. Odd slopes may often be accommodated by slanting the gagger or bending the heel. Oftentimes mistakes are made in setting gaggers improperly and cause trouble. A few ways of setting gaggers so they do not hold as desired are shown in Fig. 17. At B the gagger will hold the sand above all right, but the sand below is liable to drop. In this cope the desired end could be accomplished by placing the gagger against the bar at right angles and have the heel parallel to the face of the slope.

At C the heel comes onto the slope rightly, but the length of the gagger does not come against a bar, therefore it does not hold anything. In almost every case the gagger would drop down when the cope is lifted off. At D the gagger is placed at a slight slope to the bar and its heel parallel with the parting. This will usually hold quite well, but is not strong nor a good way to set the gagger. The holding power depends upon the sand pressing the gagger against the bar firmly and compressing closely around it. Another mistake sometimes made in setting gaggers is to have several located in a corner against one another and the heels radiating in different directions to hold in a difficult place. The sand can not compress around all the gaggers or hold them firmly together. Part of them are held only by the friction of one on the other, which is insufficient, and will drop out.

The number of gaggers needed is dependent upon the sand used and the width and depth of the body of sand lifted. When holding a corner or edge of sand by a gagger, have the gagger as near as possible to the edge and parallel with it. Always be sure the gagger is covered with at least a thin coating of sand. If not, the iron is liable to cause an explosion when coming in contact with the wet rust. Before setting in the sand, the heel of the gagger must be wet in clay wash or flour paste. Otherwise the sand will not stick to it. Have at least two-thirds of the length of the gagger come against the bar, and have the gagger as long as the cope will allow.

Soldiers are wooden strips or pieces placed in the sand to anchor the body together. They are made of size, length, and shape to suit the case where they are to be

used. Oftentimes soldiers are placed beside bars to hold hanging bodies of sand, instead of having special bars.

The holding power of soldiers is much greater than that of rods or nails, as the sand packs against their uneven surface and will not give without tearing up the entire body of sand. This will be fully appreciated if you try to pull a soldier out after it is rammed into the sand. The customary use is for holding small bodies of sand that can not be held by gagers. It is not necessary to have the soldier come against a bar. It holds firmly when in the body of the sand itself.

In setting soldiers, they should have the lower end wet in clay wash and pressed down to place in the sand before ramming. The sand should be in a loose coating of about one inch over the parting to be soldiered, then when the soldier is placed, some sand will remain below the wood, but there should not be a thick coating that may fall away after the pattern is removed. The main precaution is to be sure that the wood is covered by sand and not have that coating such that it may fall away and expose the soldier. In case the soldier is exposed to the mold, the molten metal will ignite the wood, giving gases that can not escape fast enough, thus causing the metal to blow. This sometimes throws the metal for a great distance, endangering the safety of the men near by. Even a very thin coat of sand will prevent the blowing from the soldier.

The points or corners of a mold are usually held by **nails or rods**. When a body of sand comes under the pattern, the nails or rods are set similarly to soldiers and rammed into the sand. When the pattern is liable to

tear in drawing or a body of sand is not strong in itself, it should be well nailed when being rammed.

Green sand cores which are exposed at the parting may best be nailed after the flask is rammed, for then the nail head supports the surface of the sand while the nail strengthens the entire body of the core. Whenever there is doubt of the strength of a corner or core, be sure to secure well by nails.

Where the mold is of such shape as to endanger the metal cutting at any point, the part should be well nailed after the pattern is removed, leaving the heads of the nails exposed. A few nails placed where a corner or surface is liable to cut or wash by the inflowing metal will prevent the washing away of the sand and will secure the surface in a surprising degree.

Rods are often rammed in the sand to strengthen and bind a body of sand that must resist a pressure from the metal. Any large green sand core must be well rodded to give the mass strength and firmness. When the surface of a green sand mold must resist strong pressure of the metal, the sand must be well tied together with rods. In a pit mold for fly wheels, the head in the risers gives a head on the sand of from 2 ft. to 4 ft., which means a pressure per square inch of from 8 to 14 pounds. This is resisted by rods laid close together in the sand when the mold is rammed. In pockets having metal under a portion of them, giving a strong lifting pressure, rods are laid in to take up the strain and secure the pocket firmly.

A molder's skill is shown in his ability to **patch** a mold, much more than in any other part of his trade.

In some cases patching and botching are synonymous, but with a good molder the latter is not known. Many patterns can not be removed from the sand without more or less tearing of the mold, and many old patterns are used that an unskilled man would think impossible to get a good casting from. A good molder will be able to repair a mold that seems almost completely ruined when the pattern is removed, and to get as good a casting as though the pattern were perfect and he secured a good draw; the difference being mainly in the time necessary to finish the mold.

Practice and experience with different cases and conditions can alone fit a man to cope with cases requiring much patching, but we can offer a few suggestions that may be helpful to the beginner. When the sand is dry or tempered properly for the main body of the mold, it is nearly impossible to patch the sand at corners or difficult places. To begin, then, the part to be patched should be dampened with the swab, being careful not to wet the sand so as to cause the casting to blow. In patching a corner, place a tool or a straight face against one side and press the sand in at the other. A good corner can not be made with a single tool alone. Sand pressed on with the fingers may be added to and will hold firmly. When put on with a trowel, a surface is made which will not unite well with the sand put on afterwards. Patching done with the fingers will not cause a scab on the casting, but slicking a patch may act similarly to being rammed too hard at that point. Where much sand is to be put on, put nails in the place to be patched so the heads will come a little below the finished surface.

The nails help to hold the sand while putting it on and secure the patch after it is finished. Whenever the patched part is quite large, it should be well nailed after finishing, so that the heads come flush with the surface. In patching down in a mold, sand may be put on by pressing small balls of sand onto a tool so that it will carry its weight, then lower to the desired place and lightly slick on.

In finishing the mold, the entire surface must be closely examined to be sure that it conforms to the casting desired. The loose sand at the edges must be pressed back to place or removed so that it will not fall into the mold when the flask is closed, thus causing a dirty casting. All loose sand in the path of the inflowing metal must be removed. Be sure the runners are made so that the sand will not wash when pouring the mold.

The last thing before closing a mold, a molder should see that all loose sand is removed and the mold is clean. If portions of the mold are dark, light may be thrown in by a small hand mirror which may be turned so as to light the desired parts.

Thin and weak patterns have oftentimes to be strengthened by pieces which are **stopped off** in the mold, leaving the desired shape of casting. Where a pattern is uniform throughout its section and castings are desired of different lengths, a pattern is made for the greatest length and the mold is stopped off to the desired length for the casting.

In stopping off strengthening pieces, the face of the sand in the part to be filled is cut up with a tool, then filled with sand and tucked with the fingers. Fill in

small amounts at a time so the sand will be of the same hardness as other parts of the mold. When within about half an inch of the finished surface, the part should be well vented through the sand. The finished face is slicked with the trowel, being careful not to get the face too hard.

When stopping off a portion of the pattern, a stop-off piece which conforms to the pattern at that point is laid in and the end formed to the piece. When without a stop-off piece the end is formed by a trowel or a piece of wood and the sand filled in to close that part of the mold.

The face of the sand should always be cut so the sand pressed onto it will unite and hold firmly. When the metal is not to cover the face made in the stopping-off, it is not necessary to vent the sand nor to be so particular in obtaining an even hardness; but it is always advisable to be as careful with this as in cases that are more particular.

When a mold is filled, the metal freezes at the surface first. The bottom solidifies before any other part, then the other surfaces where the heat is most readily carried off. This solid surface gives a fixed form which resists any force tending to change its shape. As the metal shrinks upon solidifying, something must replace this shrinkage. After the outside surface is set, the metal is drawn from the still molten centre of the casting to replace the shrinkage. This gives a porous, honey-combed centre which has no strength. This defective condition is prevented by **feeding** hot iron to the centre of the casting while it is solidifying to replace this shrinkage.

There are two general methods of feeding a casting: first, using a sinking head; second, feeding by use of a feeding rod. A sinking head is where the mold, when standing in a vertical position, is made longer than the desired casting and of the same size. The excess length is filled with metal and allowed to sink to replace the shrinkage of the casting below. This excess is turned off, giving the solid casting. To greatly reduce the work of turning off a large part of a casting, the feeding head is made much smaller than the casting and kept open by means of a feeding rod.

The feeding head must always be large enough to enable it to be kept open until the casting below has set. When the feeding head is small, it freezes almost before a rod can be inserted, hence does not accomplish its purpose. It is always safe to expect that some of the metal will freeze to the sides of the feeder all the time, even if the metal is kept in motion constantly; hence the feeder must be increased to allow for this in proportion to the time that it should be kept open. A feeding rod can not be used to advantage in a feeder less than three inches in diameter. This can be kept open only a short time, hence becomes ineffective where the casting below requires quite a time to solidify. Where a large feeder cannot be used, due to bars or to conditions that cannot be avoided, a small one may be made to keep open longer by increasing its length and supplying hot iron to heat this portion above that of the casting.

A large riser or feeder may have a much smaller opening into the casting and still be as effective. A 3-inch feeder may have an opening into the casting $1\frac{1}{2}$ inches in

diameter and give as good results as though the full size of the feeder were opened through. This allows the use of a much larger feeder and permits of its removal from the casting as easily as the smaller one. The smaller opening is kept from freezing by use of the feeding rod.

The rod should be heated in the ladle before lowering into the feeder, to prevent chilling the iron. It should be lowered slowly into the mold until the bottom is touched, then lifted two or three inches and given an up-and-down motion. Due to this motion it is commonly called "pumping," or "churning," a casting. The feed rod should not strike the bottom of the mold, as it is liable to punch a hole in the mold, causing a bunch on the casting. The rod should be held at one side of the centre and moved around to keep as large an opening as possible at the entrance of the feeder into the casting. A casting properly fed will freeze from the bottom and slowly crowd the feed rod out of the casting until at last it is only in the riser.

The job of feeding a casting is not a pleasant one. The direct radiation from the metal and the burning gases about the flask make it very hot and disagreeable work. For this reason, many molders will freeze up a riser long before the casting below has set. It is very marked that often in feeding a number of the same castings, poured at the same time, part of the men will have their feeders frozen long before the others do. Those who froze theirs first have castings the same on the surface as the others, but the centres would be very different were the castings cut open. The man keeping his feeder open the longest has the strongest and most solid casting.

The size of the rod used is unimportant except when it is so large that it closes up the feeder rather than keeping it open. In a feeder smaller than 3 in., the feeding rod should be $\frac{1}{4}$ -in. For larger feeders, the rod may be increased. A $\frac{3}{8}$ -in. rod is most commonly used, as larger ones become too heavy to handle and quickly tire the workman.

The proper **setting and venting of cores** is an important factor in molding. Cores are made of sand with binders which, when dry, form a solid mass of the desired shape. They are placed in a mold to make the casting different, in part, from the pattern. When burned by the molten metal, the core crumbles and leaves the casting hollow in that part. The core may be made to form recesses, to hollow out the inside, or to make holes of desired shape through the casting.

The binders which hold the sand together in the core, the entrained gases of the new sand, and other constituents of the core, burn out, forming a volume of gas that must be allowed to escape when the metal comes in contact with the core. If the gases are not properly carried off, they force their way through the easiest relief, which may be through the molten metal, causing blowing; this spoils the casting, making the body spongy, if not blowing nearly all the metal out of that portion of the mold.

When a core is made, vents are always provided to carry the gases to some particular points where they may be conducted away through the sand of the mold. A core completely surrounded with metal, except at its vent, must be well provided with free passage for the gases. Cores having the metal only on one face, as slab cores

covering a plane surface, do not require special venting, as the sand will carry off the gases freely enough. Small cores partly surrounded with metal do not require special venting, as the sand will be sufficient to take up the small amount of gases given off.

Where prints are provided on the pattern for simple cores, the setting of the core is a simple matter. The vent must be provided for, then the core is lowered into the print recess which anchors the core in the desired position. Round cores having a print at both ends must be set into the drag so as to enter the print of the cope without tearing up the top of the mold. This can be done by the eye in lining it from different directions, being sure that it is directed vertically. Horizontal cores have the print of both ends to rest the core on. The cores thus far considered are held in position by the print recess in the mold.

Many forms of cores have prints for locating the core, but nothing to hold the core from floating when the metal is poured into the mold. Small cores, as those for making a hole in a depressed lug, may be anchored by placing nails slantwise into the sand to bear against the core.

Large cores resting in the drag are held down by means of chaplets, as considered under the setting of chaplets (Fig. 57).

Many cores have no print in the drag but have one in the cope. In such cases the cores are anchored in the cope by wires so as to hold their weight before the mold is poured; then when the metal tends to float the core, the sand bears the stress. In green sand copes, the core may be anchored by running a soft iron wire from the

loop in the core to the top of the cope, then fastening firmly to a cross bar or to a rod resting on the cope bars. In dry sand copes having heavy cores, the cores are often bolted to cross beams by bolts having a hook to enter the loop in the core.

Cores are sometimes of such form or weight as to require straps for lowering them into the mold. Heavy cores may be set by a crane, when straps are used, which bend easily to prevent tearing the sand when being removed from the mold.

Chaplets are used for anchoring cores into a mold when the cores are of such shape that they are not properly supported by the sand. The forms and types of these chaplets vary greatly. The two main types are the **single-headed** and the **double-headed** chaplets, as shown in Fig. 56. The simple form of single-headed chaplet is shown at *a*. This has the forged head, having burrs at *N* to secure the chaplet more firmly in the metal. The end may be sharp or blunt, to suit the place where it is to be used. *b* shows a stem on which a head of desired size and shape may be riveted. *d* shows the double-end forged chaplet. These are made of any desired length between outside faces varying by $\frac{1}{16}$ of an inch. *c* is a stem for a double-headed chaplet. Any size or form of head may be riveted on to suit particular cases. *e* shows a double-end chaplet and nail. The nail holds the chaplet in position before the core rests on it. This assists in setting in some cases. The one shown has riveted heads, making use of a stem on which the desired heads are placed. *f* gives a form of chaplet made of cast iron. This is a cheap double-end chaplet which may be made

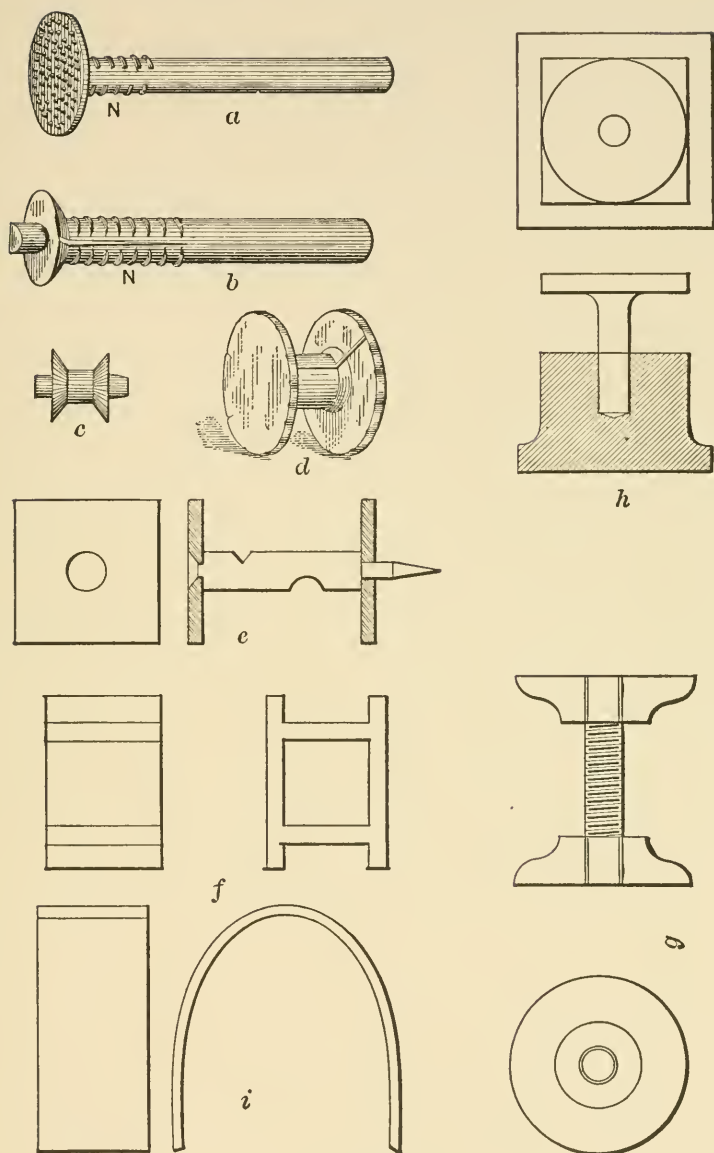

FIG. 56.

where it is used. *g* shows an adjustable double-end chaplet. It is threaded into both heads with the stem threaded to allow the adjustment. The chaplet and stand are shown at *h*. This enables quick adjustment of chaplets, as the stand is rammed in the drag against the pattern; hence the chaplet may be dropped into place when the pattern is removed. A form of spring chaplet shown at *i* may be used to substitute for a double-headed chaplet and springs to give the desired distance between faces.

The most common forms of chaplets are those shown at *a*, *b*, *c*, and *d*. There are factories making these of all sizes and shapes. They may be purchased at a lower cost than they could be made without the use of special machinery.

In using chaplets, a few precautions should be observed. Chaplets placed in a mold weaken the resulting casting in a greater or less degree. It is always preferable to avoid their use where possible. They weaken the casting: first, by introducing a foreign metal into the casting, thus destroying the uniformity of the metal; second, by forming blow-holes or porous metal about chaplet; and third, by failing to unite with the metal, thus becoming loose or leaving a hole in the casting. These evils may be greatly reduced by proper design and use. The first cannot be avoided, but may be made small by using chaplets of proper size and shape to cause the least possible break in the uniformity of the metal. The second may be nearly always avoided by proper care in regard to the condition of the surface of the chaplet. Moisture on the chaplet holds the metal away, causing blow-holes. Rust

makes the metal boil and blow, causing porous metal to form. The coating on the chaplet must be such that the iron will unite with it and lie quiet. Red lead put on with benzine makes a good coating. A tinned surface gives the best satisfaction for this purpose.

The third evil may be avoided by so shaping the chaplet that the metal will adhere closely and bind itself to the chaplet. This may be done by having notches or depressions in the stem, as shown at *e*, Fig. 56, or by barbs or burrs, as *N* on *a*. In some cases the thickness of the metal where the chaplet is placed is not sufficient to ensure a firm hold on the chaplet. The thickness should be increased around the chaplet by cutting away the sand, forming a button having the chaplet in its centre.

The effective strength or holding power of a chaplet is dependent upon the way it is set in the mold and the manner of **wedging** it after the flask is clamped. Many castings are lost, due to improper setting of the chaplets. The chaplet must have a firm bearing on the core and the pressure it is to resist must act directly against its length. When so placed that the pressure tends to move it sidewise, the resisting power is only that of the sand around the chaplet.

The chaplet set in the drag must come to a bearing where it is to remain. Those in the cope extend through and are held against the core by wedges or weights from above. Where the flask has a bottom board, the chaplets set in the drag may be pointed and driven into the bottom board, as shown at *a* and *d*, Fig. 57. The head of the chaplet should conform to the shape of the core. If the head is not shaped the same as the core at the point of

bearing, the chaplet may cut into the core, thus not holding it in the proper position, or the bearing may be on one side of the chaplet, which may tip it over. Where the sand is very deep below the point where the chaplet is to be placed, or there is no bottom board to drive the chaplet into, a block may be rammed into the sand, as at

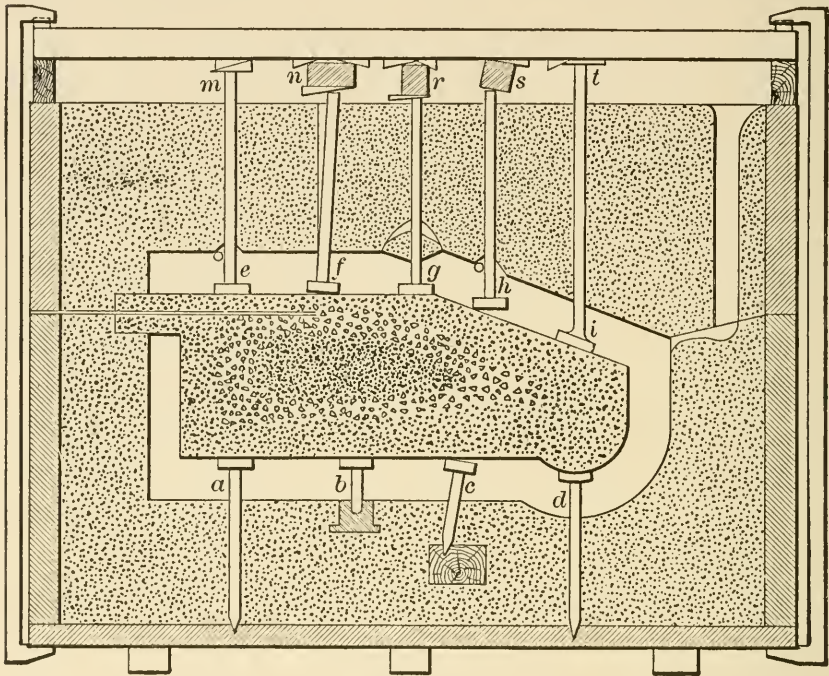

FIG. 57.

the base of *c*. The chaplet must be set vertical, for, if slanting, the effect will be that shown at *c*. This chaplet has bearing only at the edge and will hold but little, as the sand will crush beside the chaplet, allowing the core to move. Where many chaplets of the same length are to be set, as in duplicate work, much time may be saved by ramming in the mold the chaplet stand shown at *b*.

When the pattern is removed, the chaplet may be placed in the stand, thus saving the adjustment of height and driving to a firm bearing, as required in previous cases.

There are many other conditions to be considered in setting chaplets in the cope. It is best to pass a vent wire through the cope at the point where the chaplet is to be placed, then gradually increase the size of the rod until nearly the size of the chaplet, when it may be pressed through the sand. By thus slowly increasing the size of the hole, the sand is compressed and not cracked or loosened, as may be done when too great a pressure is exerted in inserting a large rod or chaplet. The chaplet should be drawn out when first inserted and the hole reamed, as shown at *o*. This avoids the danger of the chaplet pulling down the sand around it, as at *g*, when the chaplet is brought to a better bearing or wedged down after closing the cope. Where the chaplet bears on the slant side of a core, the head should be bent at the same angle as that of the core, as at *i*, to ensure a firm bearing. Where the exact shape of the core is not important, a level place may be filed into the core, thus allowing the use of a chaplet having the head at right angles to the stem. The chaplet must not be placed, as shown at *h*, Fig. 57, for it is liable to slide down the slope, thus tending to displace the core or to crush the sand around the stem of the chaplet.

Chaplets may be properly set in the mold and arranged so as to give the best service possible, but still be rendered ineffective by improper wedging. The pressure resisted by chaplets may oftentimes be very great, espe-

cially in large molds. The wedges must be so placed that the pressure may be held without any tendency to move the chaplet sidewise. This cannot be done with one wedge, as that gives the bearing of the stem onto the slant surface. The double wedge, as at *m*, gives a firm bearing on a surface at right angles to the stem of the chaplet. The taper of the wedges should be very small so as to avoid slipping when the pressure is exerted on them. Many times the chaplet is too short for using wedges alone; then a block must be inserted. This is as good as the wedges alone when the surfaces of the block and the wedges are kept at right angles to the chaplet. Some of the incorrect methods of wedging with a block are shown at *n*, *r*, and *s*. At *n* the single wedge has been driven from one side, thus tilting the chaplet so that it is liable to move over when the pressure acts against it. The single wedge effect is also shown at *s*. It is a poor plan to insert wedges from opposite sides of a block not bearing on each other, as at *r* and *n*. The block is quite liable to be tilted or the wedges to loosen at one side, causing damage.

Another improper use of wedges is shown at *t*. Here the wedges are either of different tapers, or so placed that the one resting on the chaplet has a bearing only at the ends. This may give or the wedge break when the pressure is applied. Cast-iron wedges placed in this manner on heavy work have been broken, thus allowing the core to rise.

Wedges made of hard wood give good satisfaction in light work. Wrought and cast iron wedges are more reliable and may be used in any case.

The parts of a mold are held together by properly **clamping or weighting the cope and cores** before casting. The stress upon the cope due to the molten metal when a flask is poured, is dependent upon many conditions. The main force is that of the static fluid while the metal is still a liquid. A second force, in some cases of great magnitude, is that due to the momentum of the metal when the mold fills and the metal comes up in the riser. This force may be inappreciable in many cases. In particular cases there appears to be a force exerted that cannot be well accounted for, but which must be provided against when liable to appear.

The static, or fluid, pressure on a cope may be calculated directly. Before giving the method of determining the force, let us understand what causes this force. The metal when molten is a fluid the same as water, and it passes from the fluid state to the solid when the temperature lowers below its fusion point, the same as water becomes ice as soon as it cools below 32° F. or 0° C. The same laws hold true with each fluid while in the same state of fluidity. Since water is better known, let us consider that we are handling water; then by the change of weight we will have the conditions existing in the case of molten iron. Any body lighter than water will sink into its surface until it has displaced an amount equal to its own weight. In order to press the body still further into the water a force must be exerted equal to the weight of the water displaced. When once the body becomes immersed only a slight increase of the force will sink it to any depth. This additional pressure is small enough so it may be neglected in cases that we consider. This

gives the action that takes place upon a core that is surrounded by metal. The pressure exerted upon any surface by the water is due to the area of the surface and the height of the water above that surface. In fluids the pressure at any point is equal in all directions and is transmitted without loss throughout its entire body. Thus if a tank be tight and have a small pipe extending directly above it, and it be filled with water until the pipe is partly filled, the pressure on any cross-section is the same as though the tank extended at its maximum size and were filled to the same level as that in the pipe.

The amount of force necessary to hold down a core that is surrounded with iron may be found, since it will equal the difference between its weight and that of an equal volume of iron. Sand weighs about .06 lbs. per cubic inch, and iron weighs .26 pounds. The difference between the two is therefore .2 lbs. per cubic inch. By finding the volume of the core in cubic inches and multiplying .2 lbs. by this number we have the weight necessary to hold the core down when the mold is poured. If the core has metal partly around it, the pressure will be the same as that exerted on the sides of the mold at that level.

The pressure exerted on the cope will be that due to the head above the surface of the cope and acting on the area of mold which the cope covers. This can be more plainly understood by taking a particular case, as a plate whose top is 12 in. by 24 in., and having a cope 16 in. by 24 in. and 6 in. deep. The head on the face of the cope will then be 6 inches. The area of the mold is 12×24 , or 288 square inches. The volume of metal

which would be equivalent to the pressure is 288×6 , or 1728 cubic inches. Its weight will be $1728 \times .26$, or 499.28 pounds. The weight of the cope will be its volume in cubic inches $\times .06$, the weight of a cubic inch of sand, or $26 \times 16 \times 6 \times .06 = 113.76$ pounds. Therefore the additional weight required upon the cope will be $499.28 - 113.76 = 385.52$ pounds.

The magnitude of the force due to momentum cannot be calculated and is dependent upon the style of gate and rapidity of pouring. If the mold is poured slowly, the metal rises slowly and comes up in the riser easily, exerting no force of momentum. If, on the other hand, the metal is poured in rapidly, and the mold fills quickly, the moment of the flowing metal has to be overcome by the cope, which stops its flow suddenly.

The style of gate has a great influence upon the amount of the pressure due to momentum. If the metal is poured into a basin, the fall of the metal from the ladle is broken and the iron enters the gate with but little force. Therefore the pressure in the mold will be practically that due to a head the height of the metal in the basin. When the metal is poured directly into the gate, a much greater momentum is attained. The metal falling from the ladle into the gate attains a velocity and consequent energy which is exerted upon the metal in the gate. This gives a pressure almost equivalent to that produced by a head the height from which the metal falls. The allowance necessary to cover this extra force makes the safe weight one-half larger than that calculated for the statical head. This will take care of all other force not accounted for.

Castings are often ruined by putting too great a weight upon the cope or by drawing the clamps too tight, thus causing a **crush** in the mold.

In clamping a cope, the main idea is to hold the flask firmly together so it cannot strain at any point, allowing the metal to run out. It is not necessary to put great pressure on the cope with the clamps in order to hold the metal. After the clamp is tight so it cannot give, any additional pressure on the clamp is more detrimental than beneficial. The clamp should stand nearly straight and be tightened onto the wedge with a clamping iron, as shown in Fig. 9. Clamps should be placed near enough together to avoid straining the flask between them.

The strength of a clamp throughout its central part where the stress is tense may be calculated, allowing 5000 lbs. per square inch of cross-section for cast iron and 15,000 lbs. per square inch for wrought iron. The greatest stress on the clamp is at the corner, and that is dependent upon the leverage to the bearing point. The corner must be greatly reinforced to make it equal to the other part. Wrought-iron clamps are usually made by bending a bar, which makes them weaker. The force they will resist is that necessary to bend the corner.

The volume of a given weight of iron changes as it passes from the liquid to the solid state. This diminution of volume upon solidification is called **shrinkage**. The amount of shrinkage varies with the chemical composition of the iron. The average shrinkage is an eighth inch to one foot in length. This shrinkage is allowed for in the patterns by use of the pattern scale, the dimensions of which are that amount in excess of the standard scales.

The volume also reduces after solidification as the temperature reduces to that of the atmosphere. This is often treated as the contraction of the iron, but it is more simple to combine the two and treat it as shrinkage. The feeding of large casting is for the purpose of supplying metal to the interior of the casting to replace that drawn away by the shrinkage after the outer shell has become set.

Many castings are ruined by holes in the casting where it should be solid and filled to the form of the pattern. These holes may be from either or both of two causes: first, the casting may blow, or second, the shrinkage draws away the metal from a particular point. The defects are called **blow-holes** in the first case and **shrink-holes** in the second. The causes of the first, or blow-holes, may be various. It is the gases failing to escape from the face of the mold or some core and forcing their way through the molten metal, leaving the opening when the metal sets. A few causes may be mentioned which are most common: too wet sand, too hard ramming, improper venting of sand or cores, wood or rusty iron coming in contact with the molten metal, or faces such that the metal will not lie quietly against them. These holes are characterized by rough, irregular surfaces, and have the appearance of gas enclosed.

Shrink-holes are caused by the drawing away of the metal to replace the shrinkage while solidifying. These are caused by failure to supply feeding iron to the heavy parts after the surface has set. It may be due to the form of the casting or to insufficient feeding when such is provided. The point where such a shrink-hole is most

liable to be is where there is a break in the regular surface of the casting, as under a feeding head which was of insufficient size, where the gate or riser is cut into the casting, where a lighter part of the casting joins to the heavier part, or at the top surface when no weak point is adjacent.

These holes are characterized by smooth holes depressed into the casting with solid bases, or depressions in the casting having the appearance of a shell solidifying in contact with the face of the mold, then drawn down by the shrinkage. When the shrink-hole is not at the surface it may take a very different appearance. The honeycombing at the centre of large castings is due to the shrinkage drawing the metal away from the centre after the outer shell has become of such strength as to resist the shrinkage strains.

The remedies for such shrink-holes are to make feeding heads of ample size and feed the casting until the shrinkage is provided for, to have the feeder connected to the heaviest part of the casting, to supply a feeder where the shrink-holes appear, or, when feeding with a rod, to keep the feeder open until the casting is set by supplying hot iron in the feeding head.

Burning on, or casting on, is the uniting of two parts of a casting or the forming of a new part onto a casting. It is the welding of the cast-iron parts. In order to form such a weld the face of the casting must be heated to a plastic or molten state. This is accomplished by pouring hot molten metal over the surface where the weld is to be made, until it starts to melt or becomes plastic.

Often the arms of pulley castings break in cooling. When the other parts are sound, the arms may be burned together, forming a perfect casting. This is done by chipping away the edges of the break so as to expose the surfaces of the casting. The pulley is laid onto a sand bed so the top of the arm is level. A dry sand core is fitted about the arm at the bottom and sides of the break, leaving its top entirely exposed. A runner is made to lead the overflow away to pig beds. The burning is accomplished by pouring a constant stream of metal onto the break until the surfaces become plastic or molten. The pouring is stopped, leaving the opening between the cores filled, which unites the broken surfaces.

The excess metal is chipped off, giving the repaired casting. The progress of the burning can be determined by scraping the face with a rod while the metal is being poured onto it. When the face of the casting begins to melt it can be felt to soften under the rod. When the hard spots are felt, the inflowing metal should be directed onto them until the entire surface softens, which marks the completion of the process.

The method of casting a piece onto a casting may be illustrated by forming a portion of the bracket onto the column shown in Fig. 43. Consider the bracket to be broken off along the dotted line *ab*. The column is laid on the sand so the face, *a*, is level. Dry sand cores are fitted to enclose the bracket, giving the desired form, with the top side, *a*, open. A small hole is left through the core at *b*. A runner is led from this hole to the pig bed. The iron is poured onto the broken surface at the rate the opening will allow it to escape. The stream is directed

onto different points until the entire surface becomes plastic. The opening at *b* is then closed with a clay ball and the bracket filled with metal, which forms the desired casting.

Bench molding includes the light work where the mold is made upon a bench, and after completion the mold is placed upon the floor for casting. The bench is so fitted that the sand-pile is under it while shelves are attached for holding the tools within convenient reach. The bench is moved back over the sand-pile as it is used, while the molds are placed in front in a convenient arrangement for pouring. The molder, being in a standing position, is more comfortable and can produce more molds than on the floor in a stooping position.

The snap-flask is especially suited to this class of work. Individual flasks of small sizes are also used on the bench. The flasks are of such sizes that they may be handled easily from the bench to floor after the mold is finished. Ordinarily the individual flask should not exceed 16 inches square.

Bench molding is used extensively in brass foundries. The sand is mixed and tempered in a box or trough within convenient reach of the bench.

Most patterns have the lines of parting at different levels at different parts of the pattern. In these cases, if the pattern were laid on a plain board, the molder would be obliged to cut away the sand to the line of parting of pattern and slick the surface for the parting of the mold. To avoid this loss of time, a special **follow-board** is made which conforms to the pattern and forms the desired parting surface on the drag.

A **match** is a follow-board made from new sand rammed hard, core mixtures, or any convenient material that will maintain its shape firmly. A match is often made for the present use for a special order. With standard patterns the match is made permanent and goes with the pattern. A permanent match may be cheaply made of core mixtures. The preferable mixture is that of linseed oil and fine sand, because it holds its shape firmly and is not affected by dampness.

When there are not enough castings to be made from a pattern to pay to shape a special follow-board, and the pattern projects into the cope, it is often desirable to make a match of green sand in the cope with the pattern at its proper location. The drag is rammed up in its position on the cope. When turned over the cope is removed, the sand is cleared away, and the parting of the drag is prepared for ramming the cope.

A plain board is used as a turn-over or follow-board with patterns having plain surfaces or the parting nearly in the plane of the face of the drag.

Molding machines are for the purpose of expediting the operation of molding. The term molding machine does not mean that the machine will do the work of forming a mold. Molding machines may be classified under three general heads: first, the machine for mechanically drawing the pattern; second, the molding press; and, third, the machine with press and mechanical drawing of the pattern.

In the first class of machine, the sand is rammed by hand in the usual manner. When ready to be removed from the machine, the pattern is drawn down by mechan-

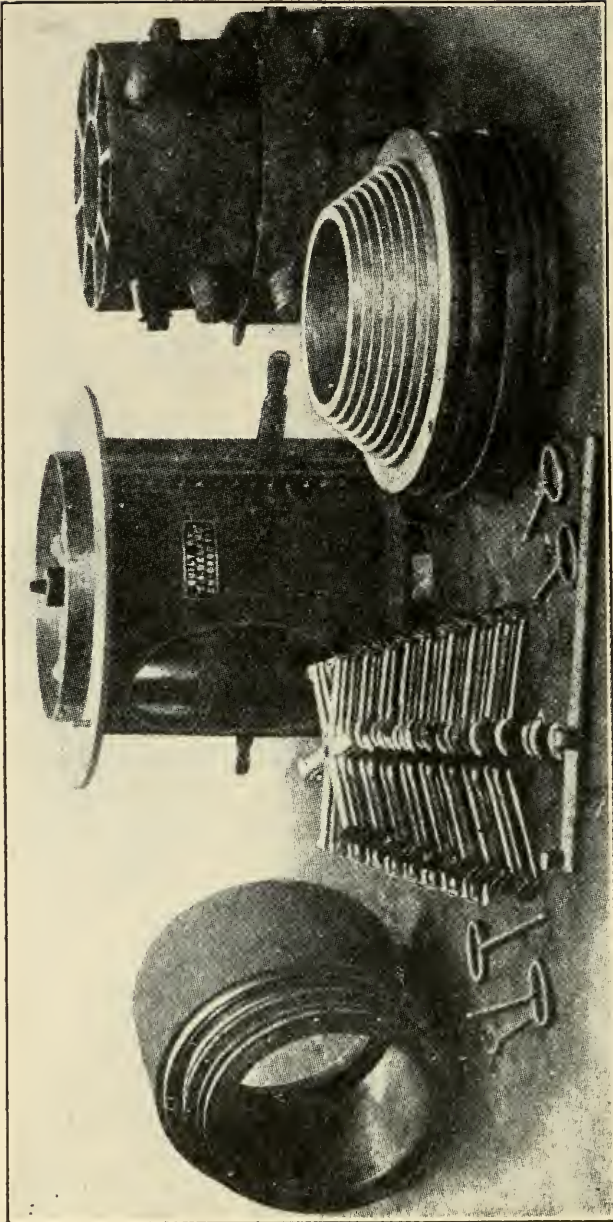

FIG. 58.

ical means, usually a lever or rack and pinion. The pattern is drawn through a stripping plate, which prevents the sand from tearing and makes possible the performing of the operation more rapidly. The hand is unsteady and cannot hold the pattern so as to move it out of the mold perpendicular to its face; hence it takes much time and skill to draw the pattern without tearing the mold.

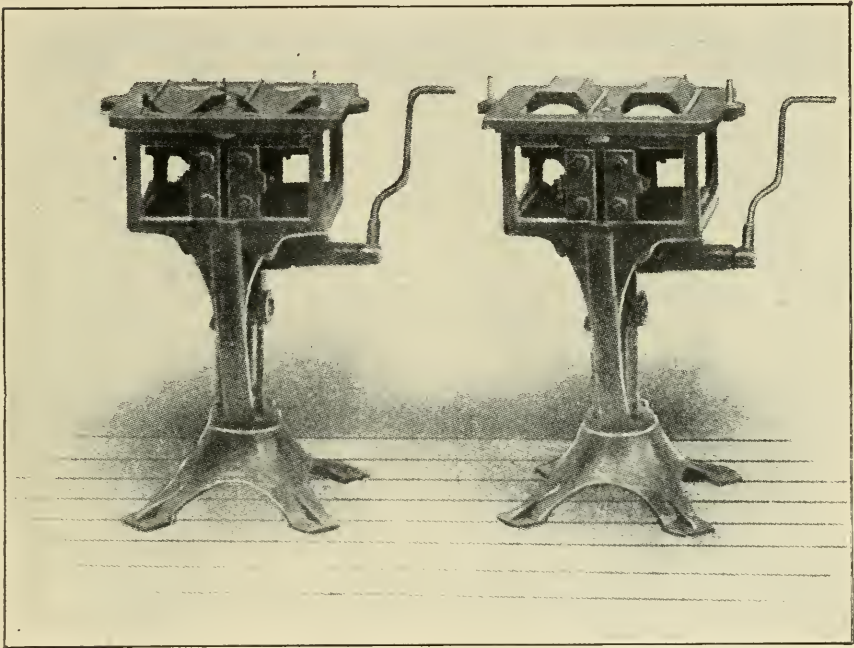

FIG. 59.

This type of machine is suited to a wide range of castings. Many manufacturers of molding machines are fitted to build a machine for a very great variety of patterns. One machine of this class is shown in Fig. 58. It is for making pulleys of any desired size and width of face up to about 44 in. diameter with 24 in. face. The range for each machine is about 12 in. on the diameter;

i.e., a machine will make all sizes from 6 in. to 18 in. in diameter. The changeable parts are the pattern ring, the

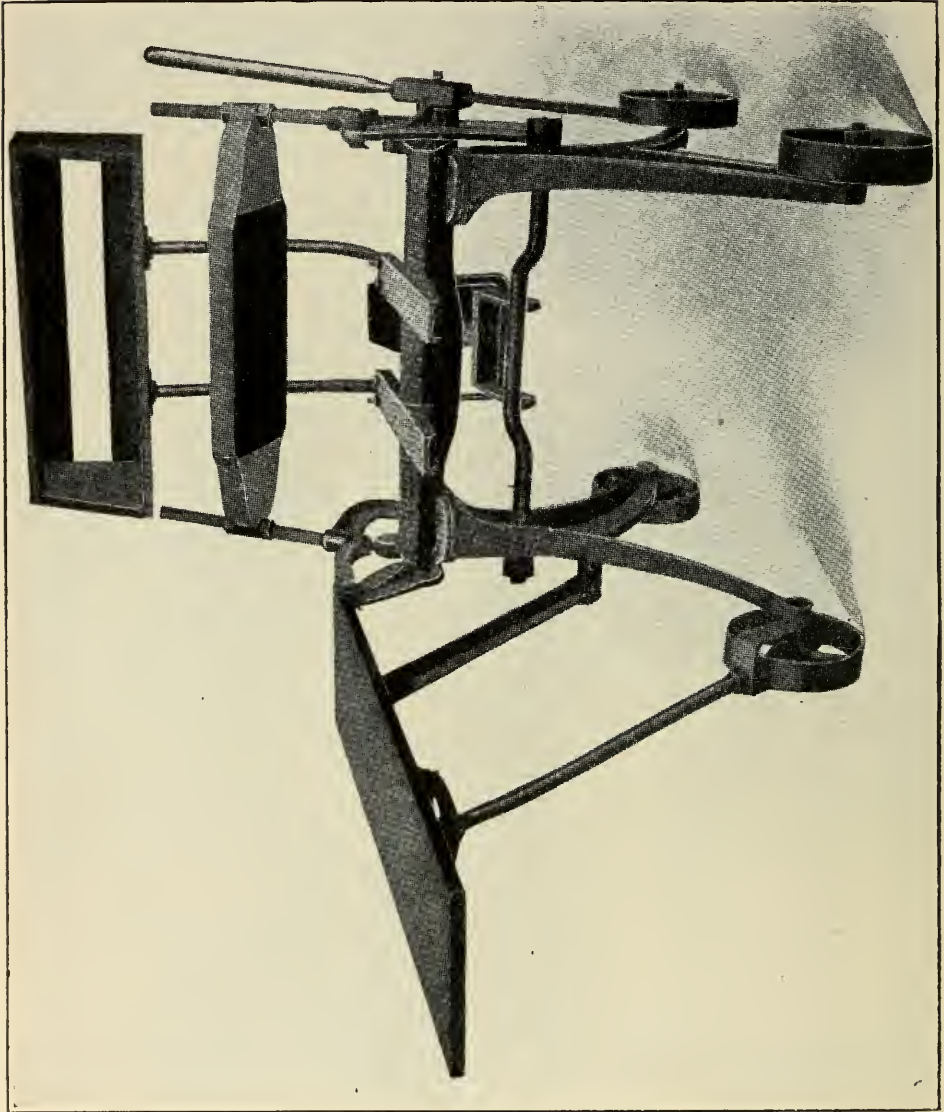

FIG. 60.

arms, and the stripping plates for each size, as shown in Fig. 58. The cope and drag are rammed on the same

machine, and the pins are so arranged that the joint comes together correctly when the flask is closed.

The machine shown in Fig. 59 is one of a great variety

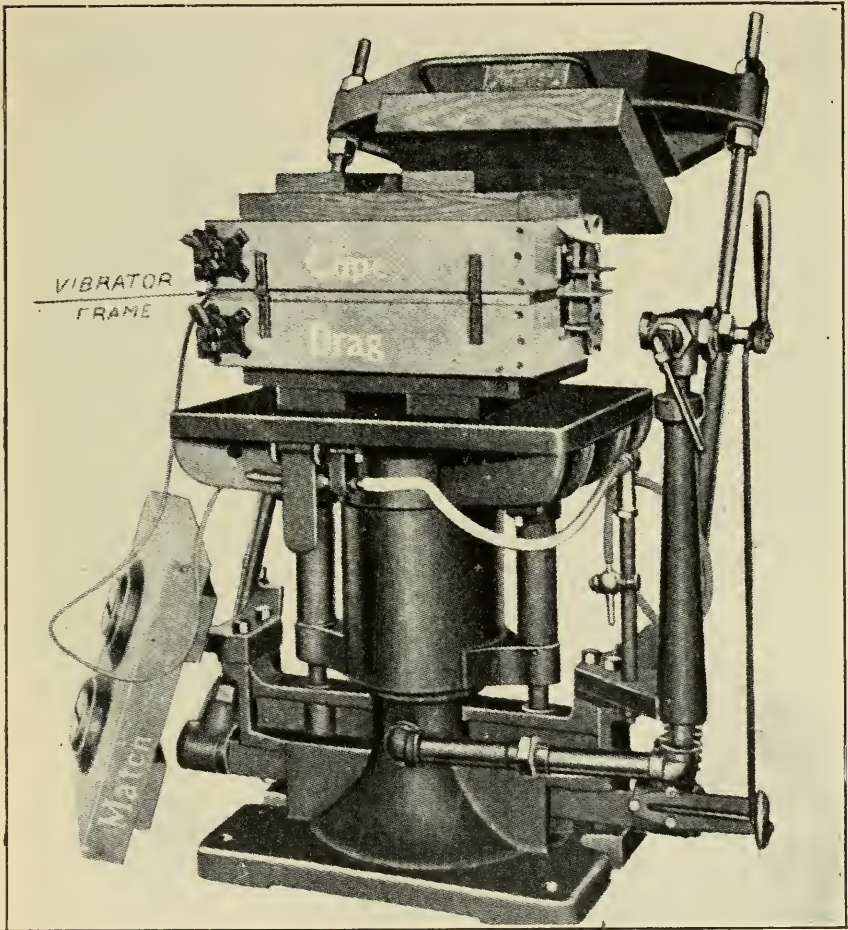

FIG. 61.

of machines which are for a special casting. One machine forms the cope while the other forms the drag. These two machines are combined in one for some pat-

terns; then each flask contains two castings. Special flasks are required for all this type of machine.

The second class of machine performs the operation of

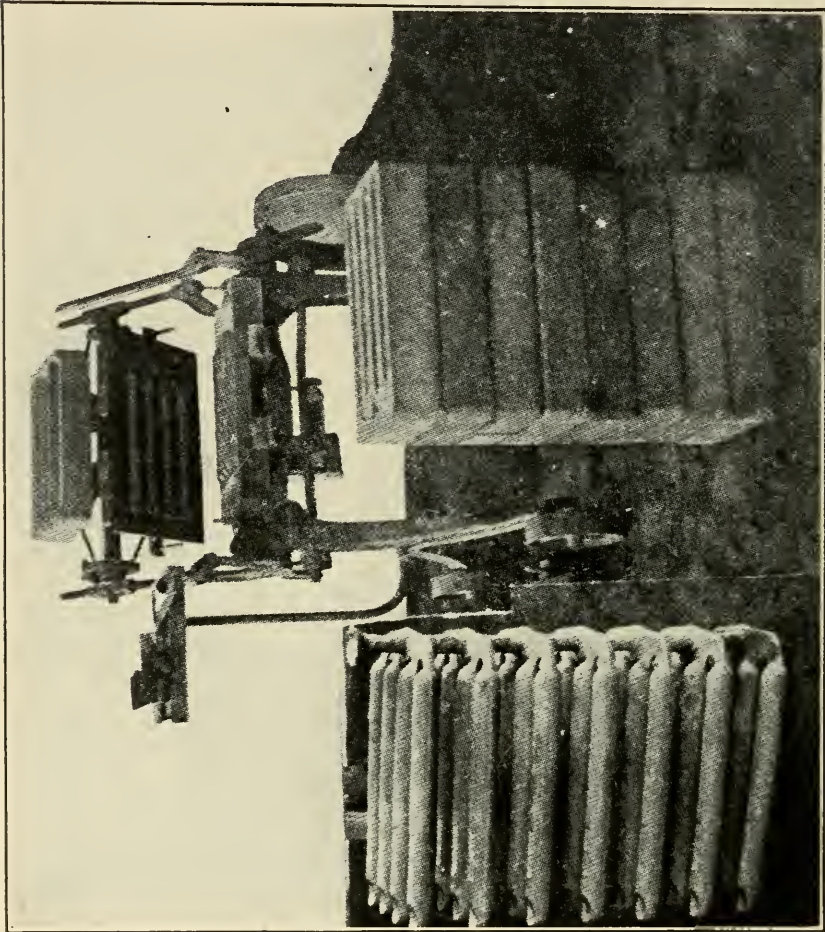

FIG. 62.

ramming the sand in the flask, while all the other operations are performed by hand. Fig. 60 represents a press molding machine, or "squeezer." The machine fulfills the offices of the bench used in bench molding, and also

has the presser head which compresses the sand into the flask instead of ramming by hand. The work handled on these machines is the same as that done on the bench. The snap-flask is used on all small machines.

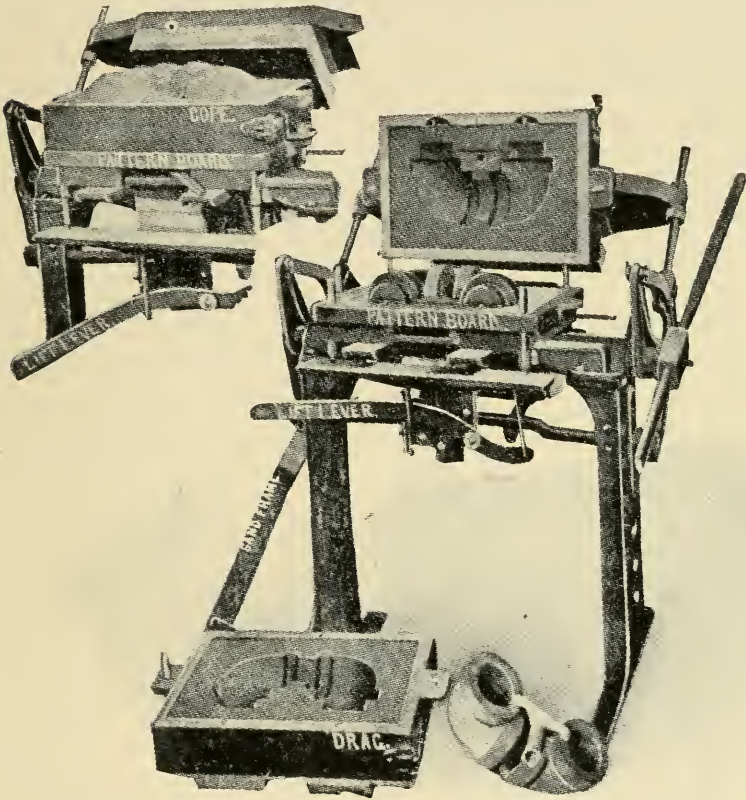

FIG. 63.

Fig. 61 represents a press molding machine having pneumatic connections. The pattern is loosened by the vibrator frame when the cope is ready to be lifted.

Fig. 62 shows a multiple mold made by the use of a press molding machine and the casting that is obtained

from the mold. This secures the making of a great number of molds on a small floor space.

The third class of molding machine performs the operation of ramming and drawing the pattern. Fig. 63 shows such a machine for making ells, as shown at the bottom of the figure. The presser head conforms to the pattern, leaving the cope as shown after the sand has been compressed. Before compressing the sand into the flask, the sand frame is placed upon the flask and filled to its top. The degree of hardness due to the press is dependent upon the depth of this sand frame. After striking off and venting, the flask is lifted off from the pattern by the lift lever, thus mechanically drawing the pattern. The pattern board forms the stripping plate.

These machines are made for many special patterns and are claimed to give good results; and they very much reduce the cost of making the mold.

CHAPTER IV

CORES, CORE BOXES, CORE MACHINES, AND DRYING OVENS

Cores are bodies of sand in the mold for forming interior openings or holes in the casting. They may be made of green sand, dry sand, or loam. Some patterns are of such form that the core is formed by the pattern. Generally the core is made separate from the mold and placed into it. When made in green sand it maintains the shape more accurately than dry sand, as the core is often distorted in drying. It requires more skill and time to form green sand cores than dry sand, hence the dry sand is used when the core is not simple or easily made in green sand.

Dry sand cores may be made in a great variety of shapes to suit any case. They are made strong enough to resist the pressure of the metal, and may be anchored so as to be almost surrounded by metal, leaving an opening through which the gases escape. The use of cores greatly simplifies molding in many cases. They may be used to stop off portions of the pattern, to prevent the necessity of many parts to the flask, to form irregularities and pockets that would be difficult to make with the pattern, and to form parts of molds instead of using a pattern, as in pit molding.

A **dry sand core** is any form made in sand mixtures, dried until hard to allow handling, and used to form part of a mold. These cores may be made in any form from the plain to the very intricate and irregular cores required in some castings. When properly dried, the core becomes hard so it may be handled, and may be anchored by use of chaplets when necessary. The binder used in the mixture holds the sand together so that shapes may be easily made which would be very difficult to form in green sand. Dry sand cores may be made strong enough to support the sand of portions of a mold or to resist great pressures from the metal.

The proper **venting** of cores is a necessity. All core mixtures have a binder which holds the sand together when dried. This binder burns out when in contact with the molten iron, giving off gases which greatly increases that in the new sand used in the core. This formation of gas must have free relief within the core to prevent its forcing its escape through the metal. All mixtures for cores must be sufficiently open to give free passage for the gases.

Cores having metal against one face only will not require any special vents. Small round cores require a vent through the centre. This should extend throughout its length. Cores having one face not covered by the metal may be vented to this face by a vent wire to give the necessary relief to the gases.

When the core is large or not easily vented, coke, cinders, stones, or any very open material is placed in the core to collect the gases, which are led off by an opening to the outside. Straight cores may be vented by rods

placed in the box when ramming the core. Crooked cores are vented by many methods. When large enough to use coke without weakening the core, the vent may be led out by placing coke through the centre of the crooked part to lead to the vent opening. Small crooked cores may be vented in many ways. A roll of paraffine laid through the core when rammed will melt and run out when the core is dried, giving the desired vent. Straight vents may be made to the bent portion of a core, and after drying these are connected by cutting away the core and laying in a string through one vent and extending into the other, then covering with new molding sand or core mixture to re-form the shape. The desired vent is left when the string is drawn out.

Core sand will admit of hard **ramming** without causing trouble when used. When rammed hard, the core will be stronger. The only precaution is to have the sand left sufficiently open to give free vent. All ramming must be done with the peñ rammer until the last surface is reached, when it is butted off. If the butt is used between the layers while filling a box, the surface made will not unite with the sand rammed on top, which makes a weak place in the core. If the sand is too wet, it should not be rammed so hard, for the pores close easier and form a solid cake, which will blow when used in the mold.

Cores may be greatly strengthened by putting **wires** and **rods** into them. The sand adheres to the rods so closely that it cannot be pulled out even from a short core. This strengthens the core far more than the simple bending of the rod, because it causes a tension in the rod, due to a tendency to elongate in an arc of a circle

whose centre is at the surface of the core. This action is effective only to the amount necessary to crush the core at that centre. Small cores needing but little strength do not require rods. The strength due to the dry sand is sufficient where there is not much pressure or weight to be borne.

The rods necessary for a core depend upon the weight of the core and the strength it must have. Many cores are of such size or shape that they would not bear their own weight without rodding. Small and thin cores may be sufficiently rodded by heavy wire. All oil cores, except very small ones, should have rods to hold them to shape while green and to give extra strength when dried. The oil will adhere to the rod so that it becomes so firmly fixed that the core will break a wire before loosening from it. Larger cores are rodded in all directions so as to tie the whole together firmly. The rods are bent to conform to the desired shape.

Many cores require to be hung in the cope. These must have hooks or loops in them for their support. Other cores require the loop for handling or setting them into the mold. The loop is made of wire or rods of the necessary strength and is placed in the desired position in the core. Except when the core is small, the loop is anchored in the core by cross rods so placed as to brace the entire core from the loop. This gives strength to the core and makes the loop capable of bearing the weight.

Large, heavy cores cannot be safely rodded by loose, separate rods, as they do not give sufficient strength. Special anchors, bars, or core irons are used in these cases. These core irons may be of cast iron, of wrought

iron welded together, or may have cast-iron bodies with wrought-iron parts. These are so shaped as to carry the entire core firmly from the core iron. The hooks or nuts for screw eyes are made solid to the core iron for handling. When the core has a large body part, loose bars and rods are used to bind the whole to the core iron. In many cases the iron in it weighs more than the sand.

Many cores are made in two or more parts and are **pasted** together after drying. This is done in order to give a form to the core that will hold its shape before drying. Large round cores will sag and deform while green if made full, supported on a side. When made in halves the support comes upon the flat side, giving sufficient strength to maintain its shape. The making of cores in halves greatly simplifies the boxes used and gives the largest face outward to work from in making the core.

The halves are pasted together after drying, to form the complete core. The paste used must be sufficiently strong to hold the core when handled, when set in the mold, and when the mold is poured. Wheat or rye flour wet with water to an even mixture forms a strong paste for this purpose. Graham flour, buckwheat flour, and fine meal each makes a paste that may be smoother but not so strong as wheat flour.

In pasting a core the halves must come to a close bearing all over the surface of the joint. When the joint surface is warped or irregular, the halves may be rubbed together until a good bearing is obtained. When large or very irregular, the high places may be filed off or rubbed down with a brick. In some cases the halves are slightly thick, causing the core to be elliptical when pasted.

Therefore a core should be measured with a caliper, and when too thick the joint should be rubbed down until the proper thickness is obtained.

The sand and dust on the joint must be brushed off before putting on the paste, as the dust takes up the paste and prevents the solid joint desired. The paste should be spread over the portion forming the joint; the core is then put together and rubbed slightly, with pressure to give close union to the parts.

In pasted cores, the vent is taken off at the joint by cutting gutters in the joint surface and leading off through the print portion. These gutters must be kept open when the core is pasted. Sometimes it is advisable to lay into the gutter a rod, a string, or anything that may be drawn out after pasting.

The paste must be dried in order to give it strength. If pasted while hot, the core will dry the paste. When pasted cold, the core should be put in the oven until dried.

If the core is properly pasted and dried, the joint will be as strong as any part of the core outside of the rods or anchors.

All cores are **baked or dried** to drive off the moisture and harden the core. If a core is heated too much or left in the oven after it is dry, the binder burns out, leaving the soft burnt sand which crumbles and cannot be used. When a core is dry it will give a clear ring when tapped with a stick or hammer. A convenient tool for sounding a core is the handle of a trowel. If the core is only partly dry the ring will be deadened.

Cores may also be tested for dryness by the odor.

When green the flour, or binder, gives an odor similar to sour dough. When dry, no steam nor odor of green binder can be detected.

The ovens for drying cores are of various kinds, chiefly using direct heat, although some have indirect heat. The indirect heat process is where the fire is in a separate chamber about the oven where the cores are dried. The direct heat process is to have the fire so placed that the heat and smoke pass directly through the oven into the chimney.

By indirect heating, the intensity of the heat is more nearly even throughout the oven. By direct, the upper part is always much hotter than the lower part. By direct heating, the chimney flue opens from the lower part of the oven at the end opposite the fire. This draws the cooler air from the bottom, which must be replaced by the hotter air from the upper part or from the fire; thus it distributes the heat more evenly and reduces the loss of heat passing into the chimney.

The ovens for small cores are fitted with shelves, upon which the plates of cores may be placed. These are so arranged as to be convenient and accessible while the oven is hot. A convenient form of oven for small cores is shown in Fig. 64. In this oven the shelves are of the form of a semicircle hung at its centre. A door is fitted to each side, thus closing the oven when the shelf is swung out or in.

The common forms of core ovens have the shelves fixed within the oven. The cores are placed upon the shelves through a door that opens in front of the shelves, or the oven is so arranged that the coremaker may go

inside the oven to the shelves arranged about in it. The ovens have the coke fire at one end while the gases are

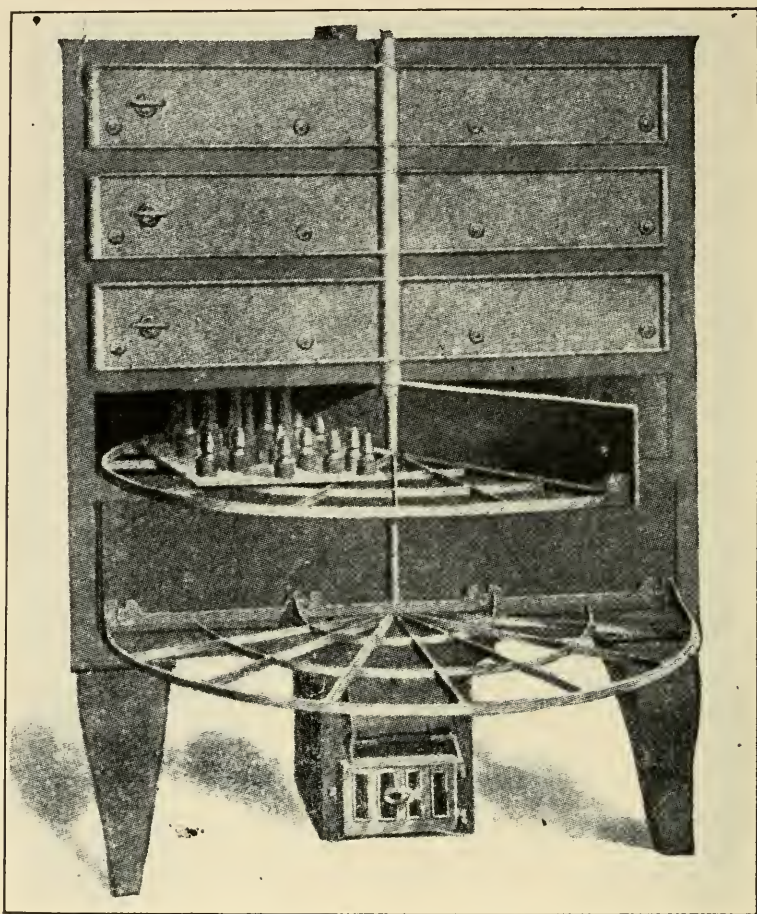

FIG. 64.

drawn off near the bottom at the opposite end. This arrangement distributes the heat as evenly as possible, but great variation is noted at various points of the oven. The shelves at the top nearest the fire are very hot, while

the ones that are low at the opposite end are not hot enough to dry a core. This distribution of heat is often

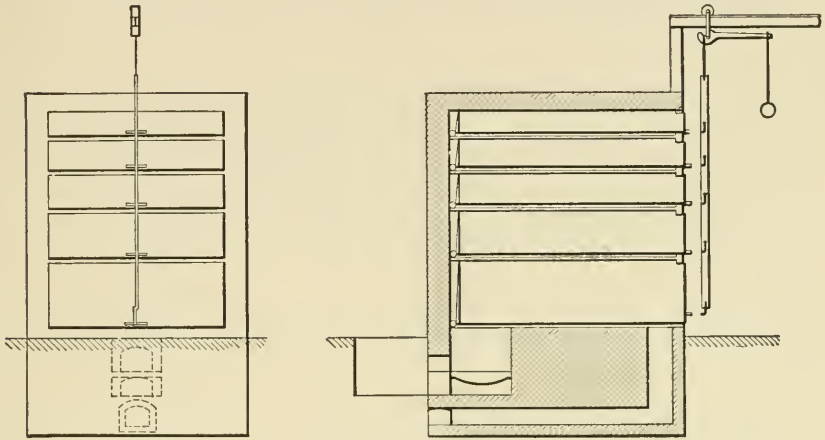

FIG. 65.

of advantage, as those cores which must be dried quickly or slightly burned, as oil cores, may be placed on the

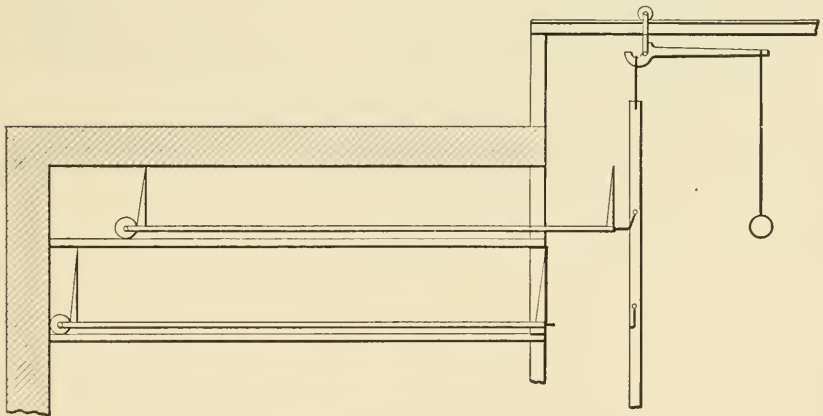

FIG. 66.

hottest shelves, while other cores may be best dried in cooler portions of the oven. Cores that are replaced

in the oven for drying the blacking or the paste may best be placed in the coolest parts of the oven.

Fig. 65 shows an elevation and a sectional view of an oven for small cores. Fig. 66 gives detail of the same,

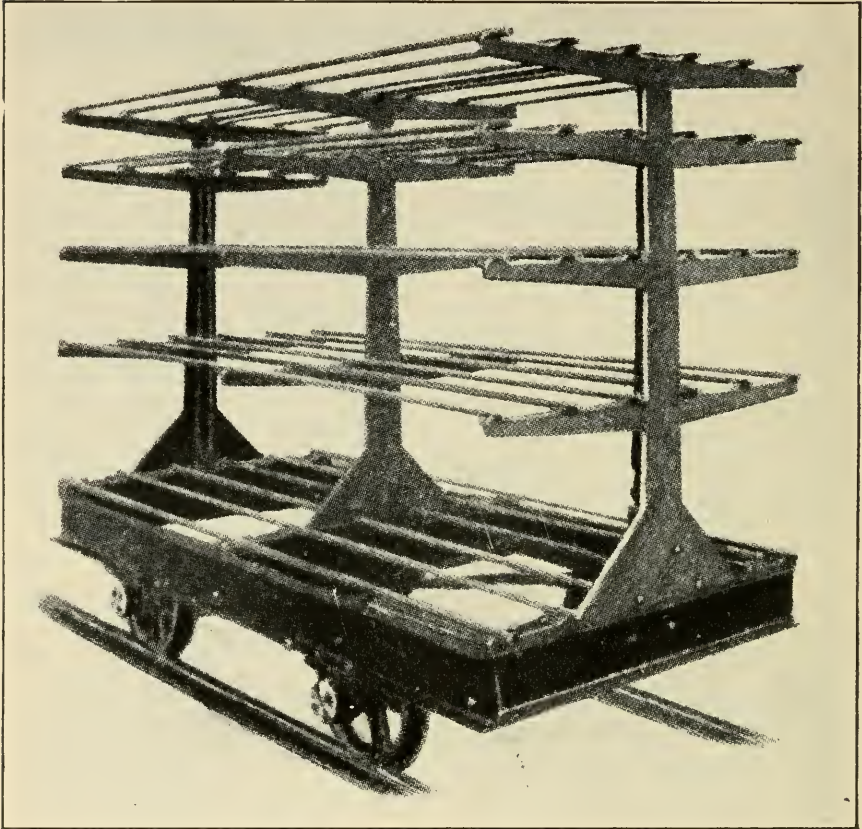

FIG. 67.

showing its operation. The shelves for the cores are mounted on wheels at the back and are carried at the front by the trolley, while the shelf is drawn out. Each shelf has its door at front and at back, so that the oven is closed when the shelf is out or in. Any one may be

drawn out by hooking the trolley to the handle, as in the case of the one in Fig. 66. The whole number may be drawn at once if so desired.

A form of oven used extensively in shops making a special line of castings is one having a core-truck with shelves fitted for the special cores used. The truck is drawn out of the oven while it is loaded or unloaded, and is replaced in the oven while drying the cores. A form



FIG. 68.

of such a truck is shown in Fig. 67. The oven for this purpose has its interior dimensions to suit the size of truck and its front end is fitted with some form of door that may be opened for removing the truck. The fire is made below the floor line at the back end of the oven and the gases drawn off at the front end near the bottom of the oven. A simple form of truck, or core car, is shown in Fig. 68. This is suited to large cores of any form. It is of advantage in jobbing shops having heavy castings, because the cores there used vary greatly in size

and form. These may be decked by placing rests on the platform and laying bars across.

The **mixture** for a core may vary greatly to suit particular conditions and different sands. The amount of binder necessary is that which will form a hard core when dry and which will not be too close, nor burn out, allowing the metal to enter into the core forming roughness on the casting.

The mixture given in Receipt No. 1 is well adapted to small cores made on the bench. With some sands this percentage may be increased. With large cores, the percentage may be reduced to that of 1 part flour to 12 parts sharp sand.

The core may be strengthened in heavy work by mixing a percentage of new molding sand with the sharp sand. The mixture given in Receipt No. 4 gives a strong core for large work, as arm cores for fly wheels, etc.

When a core is nearly surrounded by metal, it is necessary to have a strong core with as little enclosed gas as possible. Receipt No. 2 forms a core which is very strong and which may be easily vented since it is nearly an oil core. This mixture while green will not have much strength, so that it may be difficult to dry without its losing the form desired. By adding a small percentage of flour, the green core has more strength and has as much strength when dry.

Receipt No. 3 will give a hard oil core which has great strength for its size and will not blow when the metal covers the greater percentage of it. This is of greatest value in making thin split cores. The core should be

slightly burned after drying to give an open texture without injuring its strength.

The mixture given in Receipt No. 5 is for making cores by the machine. The proportions may be varied to give the best core with the easiest operation of the machine. If the sand is too wet or has too much flour, it will stick to the tube, thus clogging the machine. If too dry, the machine will not compress the sand sufficiently to give a strong core. These cores are improved by burning slightly while drying.

Receipt No. 1.—6 parts fine sharp sand, 1 part flour, wet with water. Vary the above, to suit conditions, to 12 parts sand to 1 part flour.

Receipt No. 2.—2 parts fine sharp sand, 1 part new molding sand. To 75 parts of mixture add 1 part of linseed oil or core compound.

Receipt No. 3.—Add oil to the sharp sand until it becomes saturated, or will show slightly on the finger-nail when pressed into the sand.

Receipt No. 4.—3 parts of sharp sand, 1 part new molding sand, 1 part flour to 8 parts of the mixture. Wet with water.

Receipt No. 5.—10 parts of medium grade sharp sand, 1 part flour. To 75 parts of mixture add 1 part linseed oil. Moisten with water until the whole adheres.

The face of the core which is to be covered with iron is coated with blacking to give a smooth face and prevent fusion with the sand.

The mixtures of blacking for dry sand molds give a very good mixture for large cores. Cheaper mixtures give good results on small cores. The simplest blacking

is the prepared coke blacking or black lead mixed with water of the desired thickness. A better mixture for light cores may be made by use of the following receipt: Mix 6 parts charcoal blacking and 1 part graphite. Wet with molasses water or sour beer.

Hay or straw is twisted into **ropes** in order to form an open band which may be placed where it gives strength in holding the sand, besides providing a free escape for the gases. It is used chiefly in loam work,

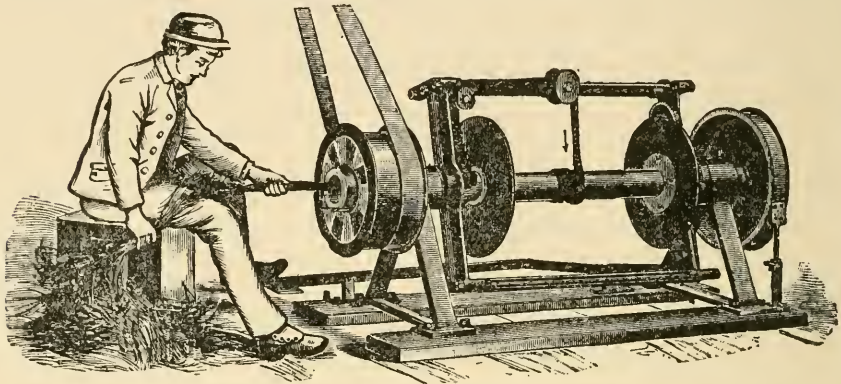

FIG. 69.

or in cores where the core barrel is used. It is sometimes used in molds to provide a vent passage from parts of the mold.

The rope is made by twisting by hand or by the use of a hay-rope twisting machine. Fig. 69 shows a machine for twisting hay rope and winding the rope upon a reel for convenience in handling.

Long round cores are often made upon a **core barrel** to give them strength and to lessen the amount of core sand necessary to make the core. The barrel is a pipe of wrought or cast iron, having holes through its surface to

allow the free escape of the gases from the outside to the inside of the barrel. When made of cast iron, the outer face has projections and unevenness for holding the core sand to the barrel. Wrought-iron barrels may be the plain pipe with vent holes drilled through at frequent intervals.

The core barrel is used for making the centre core for columns, pipes, cylinders, and round cores of that type. The core made on the core barrel is much lighter and easier to handle than a solid sand core. The barrel gives the core greater strength than the rods, especially in cores of small diameter. The amount of core mixture used to make the core will be that necessary to form a shell over the barrel, while the other core must be solid. The saving of core mixture is often worthy of consideration.

In order to form a core on a core barrel, the barrel is wrapped with hay or straw rope, then covered with loam or core mixture to give the desired diameter. The barrel is placed upon supports at each end and fitted with a crank so that it may be rotated. This mechanism with the strike or sweep for forming the face of the core is called a **core lathe**. The end supports may be a frame having a notch in the upper side for holding the barrel or centre shaft which supports the barrel. The frame extends horizontally to support the sweep. The barrel is placed upon the supports and rotated by the crank, while the coremaker guides the hay rope onto it until the desired length is covered. The surface is then covered with the core sand and compressed to give the necessary strength. The sweep is placed upon the supports and the surface swept up by rotating the barrel. The sweep

is moved toward the axis until the desired diameter of core is formed, when the surface is slicked ready for drying.

The procedure in making cores varies to quite an extent in particular cases. The general principles always apply and the variations are mainly in rodding, venting, and mixture of sand best suited to the special core desired. As it is impossible to give examples and explanation to cover every case, a few examples are given to illustrate the principal methods of making cores.

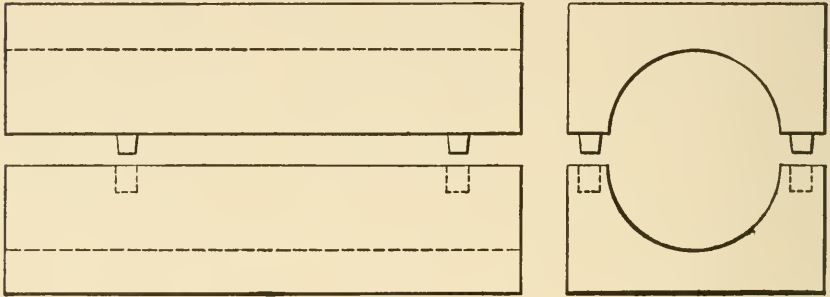

FIG. 70.

All **small cores** that do not require rodding are made by ramming the box full of the core mixture and venting toward the print side of the core. It is then ready to put on the plate for drying.

Fig. 70 shows a box for making a round core. The method of making such a core is here given. The two parts of the box are clamped together and placed on end upon a smooth board or plate. Some core sand is placed in the box, then the vent wire is pressed into the centre. The sand is rammed around the vent wire with any convenient rod. This form of core will stand to be rammed

quite hard. The ramming is continued while the sand is added in small amounts until the box is full. The top is slicked even with the box and the vent wire withdrawn. The box is inverted and the lower end slicked even with the box if it were not so left by the piece it rested upon. The clamps are removed from the box. The core is loosened by rapping the box on the sides.

Half of the box is lifted off from the core, leaving it in the lower half. This is turned out upon the plate by the following method. Place the part containing the core on the plate. With the fingers of both hands gently resting on the core, raise the box with the thumbs so that it turns over until the fingers nearly touch the plate. Gradually withdraw the fingers, allowing the core to slide down to the plate evenly and gently. The core may be moved by placing a straight side of the box against it and moving the box until the core is in the desired place.

The object of placing the vent wire before ramming is to keep it in the centre of the core. When the core is short, it may be quicker to ram the box full, then press the vent wire through, using care to keep it in the centre. When the core is long and must bear a pressure it should have a rod put in while ramming. Many core-makers press the rod in after ramming the core by running the vent wire through first. This is a very poor plan, as the sand may be loose around the rod, so that it does not strengthen the core, or it may close the vent, causing trouble in that way. In order that a rod should strengthen a core, it must be solid into the sand as a part of it.

Many cores are made in a **skeleton box** with a strike or former. This form of box is very cheap to make and

a core may be readily made in it. Fig. 71 shows such a box with its strike. This makes one-half of the core,

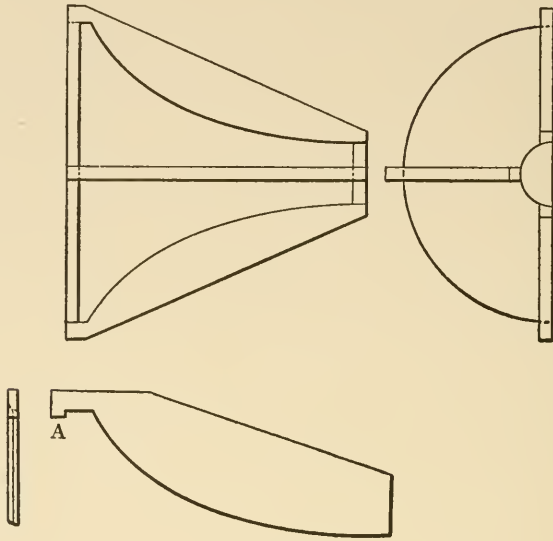

FIG. 71.

which when pasted forms the core shown in Fig. 72. This core is 18 in. in diameter at the base, 4 in. at the

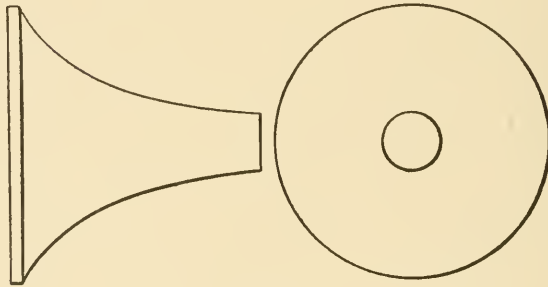

FIG. 72.

top, and 30 in. long. The core rests on prints at each end, and must be sufficiently strong at the small end to sustain the weight of the core when placed in the mold.

The box is placed upon a plate having a smooth face. A little dry sand is sprinkled over the plate to prevent the core from sticking to it. Core sand is then filled in to a depth of about two inches. A rod about 26 inches long is wet with paste and placed in the centre of the box and bedded into the sand. Sand is then filled in and rammed with the pein until it is nearly of the required size. The last sand is butted onto the surface, making a solid core to strike off. A few vents are directed to the centre of the lower side from the larger portions of the core.

The face of the core is struck off by maintaining the notch A against the end of the box and always keeping the face of the strike directed radially to the centre line of the core. The surface is slicked and brought to an even smooth surface. The box is then drawn from the core.

The second half is made in the same manner. The two halves are blackened with a medium thick mixture of the blacking and are put in the oven and dried. They are then placed together and rubbed to give a good bearing. The two ends should be tried with a caliper for the correct diameter. When too large, the core should be rubbed down until the proper diameter is reached. The halves are then taken apart and the vent gutter is cut through the centre the full length of the core and on both halves. This should connect the vents previously made through the body of the green core. The sand and dust are removed from the face of the joint and paste is put upon one-half of the core. The paste should be strung along in a thick, narrow row midway between the edge and the vent gutter. If spread thin over the surface it

may not give contact at a portion of the face. When put on thick, it squeezes out when the core is put together and makes a firm joint. Care must be taken to prevent filling the vent gutter with paste when the core is put together, thus closing the vent passage.

The half without the paste is then placed upon the other and the two pressed together with a little rubbing to force the excess of paste out of the joint. The openings still left at the joint on the sides of the core should be filled with stiff blacking if small, but when large pieces may have broken off, the interior surface is covered with paste and core mixture is pressed in to fill to the desired surface. The face of the joint may be smoothed by going over with wet blacking on a swab or brush. After the paste and blacking are dried, the core is ready for use in the mold.

The skeleton box and strike may be made use of under greatly varying conditions. Whenever there is a core or portion of a core that may be struck into the desired form with a strike, the skeleton box may be made use of. The most general use is found in making round cores, especially large sizes. The strike in this case is straight. The strike or former is also used to move lengthwise of the core instead of crosswise or around the core. In making cores for water-pipe specials, as ells, tees, etc., a former is made of the desired semicircumference, and the core is shaped by guiding upon the skeleton box or upon a core plate made to the desired outline.

The head stock core, shown in Fig. 24, is made in a **half box**, having loose pieces to form the recesses for the bearings. The halves are made the opposite way by

having reversible parts to the one box or by having two separate boxes. The preferable way is to have the one frame with the loose piece to make the desired parts. This core is thick enough to have the necessary strength without rodding. The box is filled about four inches with core sand and rammed with a small pein rammer. The loose pieces are put in place and the core sand is bedded under and around them, care being used to ram it sufficiently and to keep the pieces in their proper position. The remainder of the box is filled, rammed, and butted off. The face is struck off and surfaced with the trowel even with the top of the box. Vent gutters are cut to lead off at the print side. Slant vents are directed from the gutter under the loose pieces and into the body portions of the core. The loose pieces are then drawn from the box. The face is slicked, if necessary, then the opening is filled with molding sand of the usual temper for molding. This supports the overhanging portion of the core while it is green and is easily removed when dry.

A core plate is placed on the box and the box is turned over, holding the two firmly together. The box is rapped on all sides, then drawn vertically with light rapping on the outside of the box. The core is slicked, then dampened on the face with water and placed in the oven for drying. The face of the core is dampened to form a harder skin when the core is dried. If too much water is put on at any spot, it washes away the binder, leaving the face soft and rough with loose sand. The water may best be sprinkled on the core by wetting a brush and throwing the water from it by holding the hand and striking the brush against it with the other, so that the jar

throws the water. With a little practice the core may be dampened just as desired by this method. A more convenient method of dampening the core is by use of the spray can or spraying bellows.

The core is blackened, pasted, and finished as in the previous case, giving the completed core desired.

A simple form of core using a **special anchor** may be found in making a large round core for a cylinder. Fig. 73 shows an anchor for half of a core for a cylinder

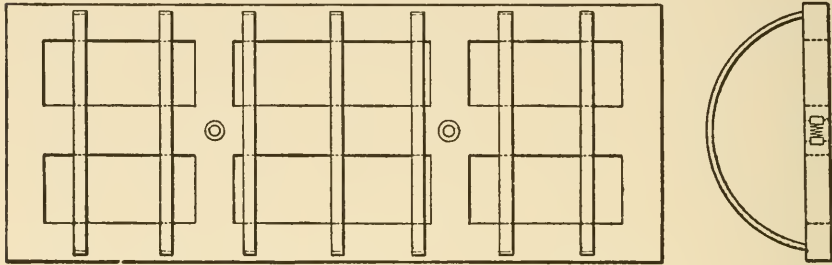

FIG. 73.

48 in. in diameter. The anchor was made for a skeleton box.

The method of making the core may be explained briefly as follows: The box is placed upon a smooth, even plate easily accessible to the drying oven. The core sand is riddled evenly over the surface enclosed by the box to a thickness of about one inch. The anchor is coated with flour paste or clay wash and placed in position within the box. When the anchor is light it should be rapped down, then tucked all around to ensure an even, hard core under the anchor. The core sand is filled in and pinned firmly. Each layer should be but 3 or 4 in. in thickness. After the anchor is covered to a thickness

of about 2 in., the core is vented, leading toward the centre. A bed of coke is laid through the centre about 10 in. wide and 5 in. deep. Long rods are laid in near the wrought-iron bands to firmly tie the sand between them. Rods are placed at the outer rim at intervals of 2 or 3 in. as the core is rammed. This size of core must be very solid in order to have sufficient strength to carry its own weight.

While ramming, it saves time to fasten pieces onto the outside of the frame of the box to hold the core to the desired form. Without the pieces on the sides, the sand will crush out or expand at the bottom while ramming on the upper portion of the core. When the ramming is completed, the pieces are taken off the side and the entire core is vented to the coke centre. It is then struck off and the surface slicked to a smooth, even face. This anchor is provided with nuts into which screw eyes are placed for handling the core. The screw eyes are left in while ramming the core. The rods must be kept at least an inch from the screw eye, so that they will not be loosened when the screw eye is removed.

The box may be taken from the core and the remainder of the core is slicked. Wet blacking is put evenly over the surface. The blacking should be as thick as will spread readily and evenly. The core is then ready to dry.

The other half has the nuts in the anchor offset from those in the first half, so that openings may be left through the entire half directly over the nuts in the previous one. When the core is together finished, the screw eyes are fastened into the lower half of the core. The second half

is made the same as the first, except that round sticks are placed exactly in the position of the nuts of the first half.

The core should be pasted while one-half is hot in order to dry the paste. The crack at the parting is filled with hard blacking or core sand, then coated with blacking and dried by replacing in the oven or by a fire built around the core.

The same core may be made in many other ways, dependent upon the appliances available. The principles are similar in making all cores having special anchors. All large cores must have special frames or anchors to give them strength. The forms of these anchors and the fitting for handling are nearly as various as the different cores in which they are used.

In many cases the core is **nearly submerged in iron** when the mold is poured. These cores must be made so as to give very free vent to the gases in order to prevent blowing in some part. Where the core is large enough to easily collect the gases at its centre and lead them off through the print, the core may be made very similar to other cores. When the core is thin or so shaped that proper venting is difficult to obtain, the mixture should be such as to give a hard core with as little gas as possible.

The core shown in Fig. 74 is for forming a pocket in a crank disk which will be filled with lead as the counterweight for balancing the engine. The core here shown is a semicircular segment whose inner radius is 10 in. and outer radius $21\frac{1}{2}$ inches. The thickness is 3 in. with four openings on one side $2\frac{1}{2}$ in. in diameter. This core

is surrounded by metal, except the openings through which the vent is led off.

To make this core, the mixture given in Receipt No. 2 proved very satisfactory. Procure four pieces of wrought-iron pipe 1 in. or $1\frac{1}{4}$ in. in diameter and 4 in. long. Burr out one end so that the pipe bulges bell-shaped. Cover the pipe well with linseed oil, then place in the centre of each print or opening and fill in with the core sand. This pipe extends to the centre of the core where the gases are led off. The entire box is filled in a little over an inch in depth with the core sand and rammed.

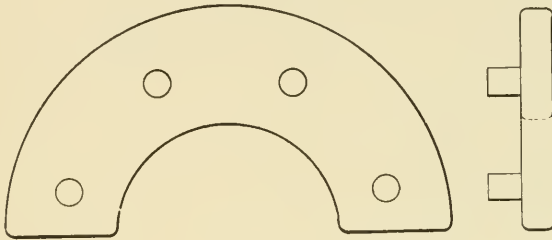

FIG. 74.

Wires are laid in to bind the core. These wires should be of such a size as to hold the core and still be easy to remove from the casting through these small openings of $2\frac{1}{2}$ in. in diameter. These wires are laid in lengthwise of the core, placing one near the outer circle and one near the inner, while one is placed about an inch away from the pipes on either side of it. The wires are bedded into the sand now in the box. Sand is filled in to the level of the top of the vent pipe.

Vent gutters are laid out just inside of the outer wires, with a similar one through the centre to connect the vent pipes. Cross gutters connect the ends and join the outer

gutter at each of the pipes, and similarly midway between the vent pipes. These gutters are made to a depth of about $\frac{1}{2}$ inch below the centre. Fine coke is laid in the gutter to a depth of about 1 inch. The coke taken is that which will pass through a No. 2 riddle and will not pass through a No. 6. The coke is then covered with coarse sharp sand or fine gravel to prevent the core sand filling up the openings between the coke. This should bring the sand above the top of the pipes. The pipes should be filled with waste or anything to prevent the sand from filling them, and the waste may be removed after the core is finished. The top of the pipes is covered with coke to connect freely with the vent gutters. This is covered with sand the same as the gutters. Core sand is filled in to the top of the gutters and rammed. Cross wires are laid at distances of about 4 or 5 inches to bind the core together. A little more sand is filled in over the entire surface of the box and long rods laid in as before. The remainder of the box is filled and rammed. The top is struck off even with the box and the face slicked smooth with the trowel. Parting sand or dry sharp sand is dusted over the face to prevent its sticking to the plate. A straight plate is clamped onto the core box and turned over, when the box may be removed giving the core as desired.

Oil or core compound readily bakes onto a plate so as to stick the core to it. When making these cores, something must be put onto the plates to prevent the oil from fastening to the plates. Other cores separate readily from the plates after drying.

The round cores of various sizes are used in so many

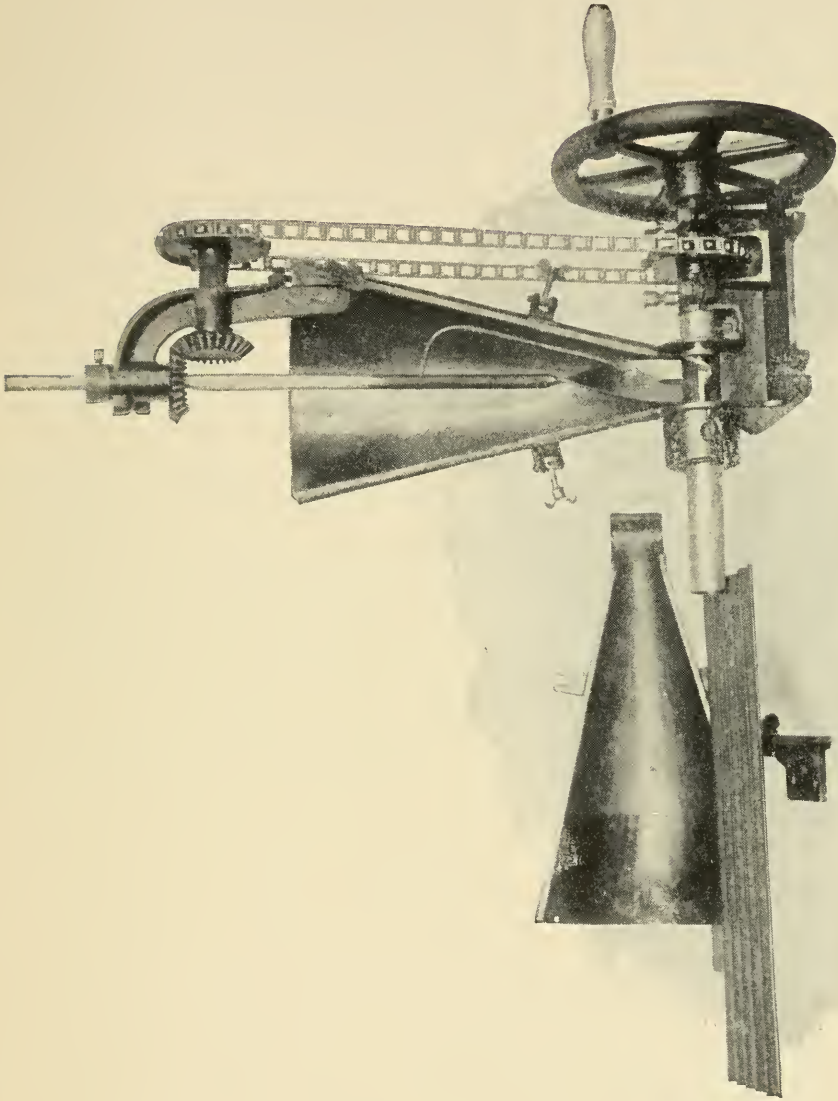

FIG. 75.

different castings that all foundries keep a supply of each size in stock. These may be cut to the length desired in any case. This is a much cheaper method than making special cores for each pattern used. The boxes for cores up to 4 in. in diameter are made similarly to those shown in Fig. 70, and of a standard length.

Machines have been invented for making these **stock cores** which greatly reduces the cost of labor. These machines are made with changeable parts for making cores up to about 3 in. in diameter. There are several manufactories making machines for this purpose. The hammer core machine shown in Fig. 75 is fitted to make cores from $\frac{3}{8}$ in. to 3 in. in diameter. The mixture is placed in the hopper and, by turning the crank wheel, is forced through the tube of the desired size by a bit directly back of the tube. These give a core vented in the centre throughout its length and of an even hardness. The ramming is dependent upon the friction of the sand on the tube through which the core passes.

The mixture that makes a very good core is one with oil and flour as a binder.

CHAPTER V

CUPOLAS, BLOWERS, AND MELTING FURNACES FOR IRON

THERE are two types of furnace most generally used for remelting cast iron in the foundry. The **reverberatory furnace** is used in places where soft grades of fuel are plentiful and where special grades of iron are necessary. This type will be explained later. The **cupola** is most generally used and regarded as the most economical furnace.

Fig. 76 shows an elevation and section of a Newton cupola which illustrates the general type and its construction. The shell is built up of iron or steel plates riveted together. This is lined with fire-brick to enable it to withstand the heat. The lining is of the same diameter from the charging door to the bottom. The bottom is fitted with doors which cover the entire diameter of the cupola so as to allow a free fall for the droppings at the end of each heat. On small cupolas up to about 30 in. in diameter, a single door is used. In most cases up to 72 in. the door is double, swinging from the centre line. In larger ones the door is made in more parts.

The **tapping hole or breast** is located above the bottom at a height to allow the sand covering to be put upon the bottom doors for holding the molten metal and for protecting the doors from the heat. The **runner or spout**

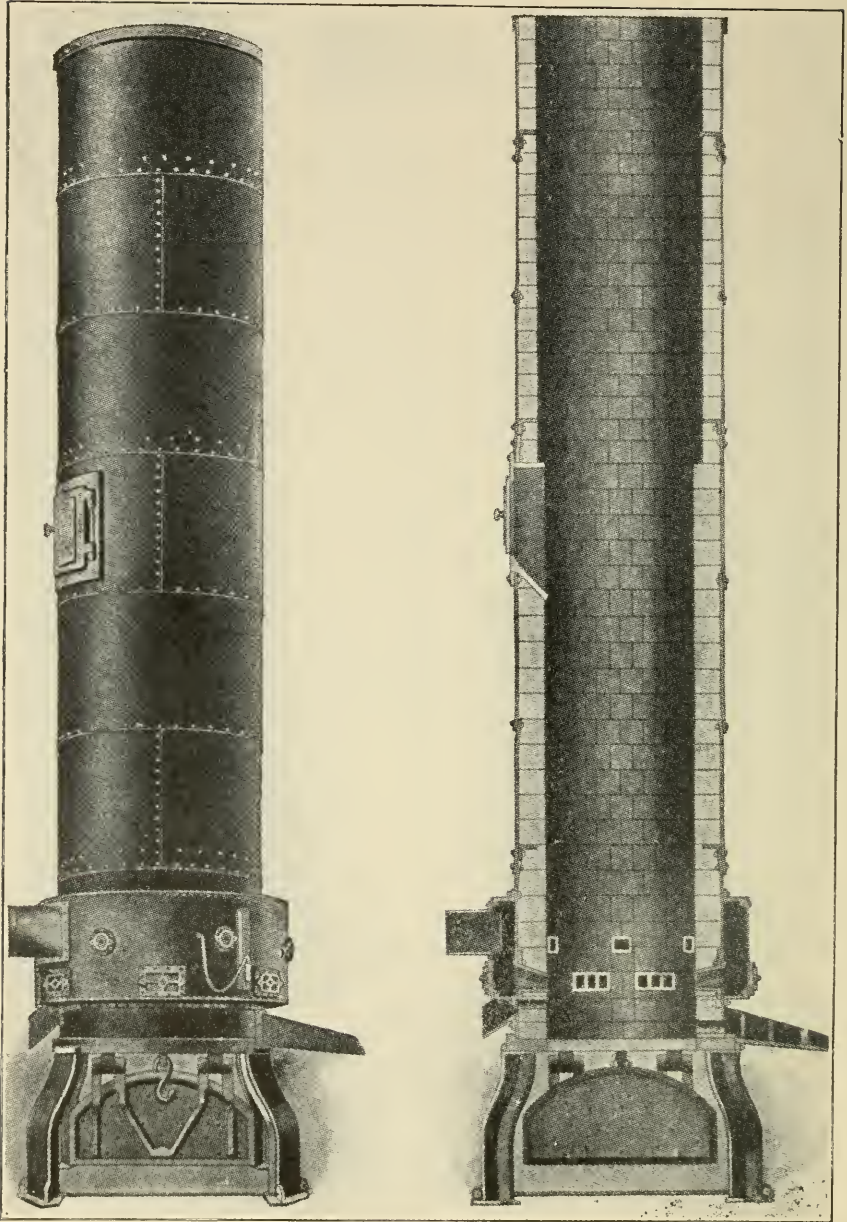

FIG. 76.

leads from the breast to conduct the metal to the receiving ladle. The **tuyères** are openings through the lining for the air blast to enter. There may be one, two, or three rows of tuyères located at different levels. The total tuyère area varies from one-tenth the cross-sectional area of the cupola, inside the lining, for small cupolas, to one-seventh for those of large diameter. A **wind-belt, or wind jacket**, surrounds the shell over the tuyères. The blast is conducted to this wind belt and enters the cupola through the tuyères. **Peep holes** are provided in the covering of the wind jacket opposite each tuyère. Through these the melter may watch the process of melting. In the figure a **manometer** is shown fastened to the wind jacket. This indicates the pressure of the blast. The amount of blast pressure varies with the size of cupola. The air must be forced to the centre of the fire to effect combustion there at the same rate as nearer the lining. In small cupolas the pressure varies from 4 to 8 oz., while in larger sizes it may be up to 14 oz. per square inch.

The **charging door** is placed at the charging floor. Its height above the tapping hole or hearth of the cupola should be such as to ensure complete combustion of the fuel, and absorption of the largest percentage of the heat by the charges, before passing the charging door.

The **hearth** is where the molten metal accumulates. It is the space between the bottom and the level of the bottom of the tuyères. The average height of the hearth is about 10 inches.

A **slag notch** is provided on all cupolas for drawing off the slag from the surface of the iron when running long

heats. The slag notch is fitted similarly to the breast of the cupola but at a level slightly below the bottom of the tuyères. It should be so arranged that the tuyère is not close on either side as the cold air chills the slag forming bridging, or obstructing the tuyère. In order to draw off the slag, the iron is allowed nearly to fill the hearth up to the slag notch. The notch is then opened, allowing the slag to flow off the surface of the iron. When the iron appears, the slag notch is closed and the tapping hole opened to draw off the iron.

An **alarm tuyère or plug** should be provided on every cupola. When the metal rises to the bottom of the tuyères, it overflows first at the alarm, thus giving warning so the metal is not allowed to flow into the wind belt and eventually fill it with the iron. A common form of alarm is to have a groove through the lowest tuyère which allows the rising metal to flow off there first. Directly below the groove a plug is fitted having its centre of soft metal which is easily melted. The hot iron or slag melts the plug, then flows to the outside on the ground where it is seen. A form which gives good results where the blast pressure does not exceed eight ounces is to have a casting with open centre and tapered flanges for holding its cover fitted to the wind jacket below the alarm tuyère. The cover has a small hole about 1 inch in diameter through its centre. About three thicknesses of common paper are placed over the cover, then slid into place, thus making it nearly air-tight, and burning through almost instantly when the cupola overflows. This form is quickly replaced, and acts more quickly than most forms of alarm.

The **lining** of a cupola is burned out more rapidly in some parts than in others. To allow renewing parts of the lining without disturbing the entire brick work, angle irons are riveted to the shell at different levels to hold the lining between those levels. The brick may then be removed between any two angle irons without disturbing the remainder of the lining.

In putting a new lining into a cupola the less clay that can be used between the bricks and have the joints sealed, the longer the lining will last. When the clay is thick in the joints, it burns quickly and crumbles, leaving the edges of the bricks exposed to the fire, thus burning them away. The clay should be mixed with water, and very thin, so that by dipping the bricks into the mixture enough will adhere to form a tight joint. The bricks should be pressed together to squeeze out the superfluous clay and to ensure a tight joint.

The shell expands as the temperature rises, while the brick changes but slightly. To avoid crushing the lining when the shell contracts and to maintain a tight lining as the shell expands, a space is left between the shell and the brick when the lining is made. This space is filled with fine cinders, a mixture of fire-clay and cinders, or dry fire-clay. This loose material protects the shell from metal breaking through the lining, and allows the shell to give without injuring the lining.

The cupola must be **prepared for each** succeeding **heat**. At the end of each heat, when all the iron has been melted, the bottom is dropped to allow the slag and refuse to fall out. There is always enough molten slag and iron left with the fuel to form a solid mass if allowed

to cool in the cupola. Some of the refuse always clings to the lining so that it does not drop clean. In some cases, the formation on the lining projects out for some distance or to nearly cover the bottom. Before another heat can be taken off, this refuse must be removed. This can be done with a small pick or pinch bar, having one end sharpened. The thick parts are broken off with a hammer, then the remainder with the bar. Care must be taken to avoid loosening or injuring the brick. Where the brick is glazed over, it should be left, for that glazing is as good protection to the brick as the clay daubing.

After the cupola has been picked out and the lining left clean, a coating of clay is put over the lining. This process is called **daubing** the cupola and the clay mixture used is called the daubing. The best clay for this purpose is fire-clay. Other mixtures are red or blue clay mixed with sharp sand in a proportion that will not crack open when dry, or 1 part of sand to 4 of clay. Too much sharp sand destroys the body of the clay so that it crumbles. The fire-clay is more expensive, but the lining will last much longer than when the mixture is used.

The daubing is spread over the face of the burned lining to a thickness of from $\frac{1}{2}$ to 1 inch. Where a brick is burned away deeper than the others, it should be filled in with pieces of brick mixed with the clay. This keeps the body of the clay thin so it will not crack or sag as is the case when thick in places. When the bricks are burned away so that the lining becomes hollowing, this should not be filled with the clay to make it even with the upper parts. If this is filled in, the clay will sag

down and become too heavy to stick to the lining. The commotion of the fuel and iron against it when melting soon starts the clay and makes it break away from the lining. This produces a large amount of slag and may cause trouble by clogging up the cupola and stopping the melting. When daubing to a thickness of $\frac{1}{2}$ to 1 inch will not keep the shell from becoming red hot during the heat, it should be relined with brick.

After the lining is prepared the **bottom** is made. This consists of a sand bed on the bottom door so prepared as to hold the iron and conduct it to the tapping hole. The bottom, or drop, door is put up and permanently propped in place. The sand is placed upon it and rammed enough to compress the surface to bear the weight of the iron. The bottom should slope back from the tapping hole so as to give a free flow of the metal when tapped out. It should not be sloped too much, as that gives force to the flow which makes it difficult to stop, and if not sloped enough the iron may freeze at the tapping hole when the metal enters it.

The sand should be very open and yet be loamy enough to hold together and not allow the metal to ooze through it. The sand may be taken from the gangway, or from the dirt pile. When too loamy it may bake hard and form a crust which will not drop, especially in small cupolas. Very open sand may be used, then after the bottom is shaped it may be coated with clay wash, which forms a firm crust on the surface.

Forming the tapping hole is an important factor in preparing the cupola. The portion of the cupola in front of the spout is called the **breast**. The opening made

in the breast for the metal to flow through is called the **tapping hole or port**.

The brick work is arched over the breast, leaving an opening for forming the tapping hole of the desired depth. For the remaining distance between the inner edge of the tapping hole and the face of the brick the form is cone-shaped of such a pitch that it enlarges rapidly toward the inside. The tapping hole should not be more than three inches long. The front may be put in before putting in the fuel for the bed, or afterwards by using the fuel for a backing to form it against. When the cupola is large enough, a good plan is to place a board against the lining to cover the breast, put the draw-plug in the desired position for the tapping hole, and ram or pack the breast into the desired shape. The plug and board are removed, then the inside is shaped with a trowel even with the brick and a conical hole from the outside to within two inches of the inner face to form the tapping hole. The breast may be made of a mixture of clay and new molding sand or a stiff clay. It is best to form the bottom of clay for four or five inches in front of the tapping hole, to prevent the tapping bar from making a hole in the bottom.

The spout should be lined with clay when the breast is put in. It is partly dried with charcoal or with wood before the fuel is charged into the cupola.

After the cupola is prepared for charging, the kindling for **starting the fire** is placed upon the bottom. Shavings are placed in front of the breast for lighting and the wood on top of them. A sufficient amount of wood is put upon the kindling to ensure its starting the coke to

a good fire. Coke is placed upon the wood to the amount of the bed charge. It is then ready to light. Iron should not be charged until the coke begins to burn or until fire

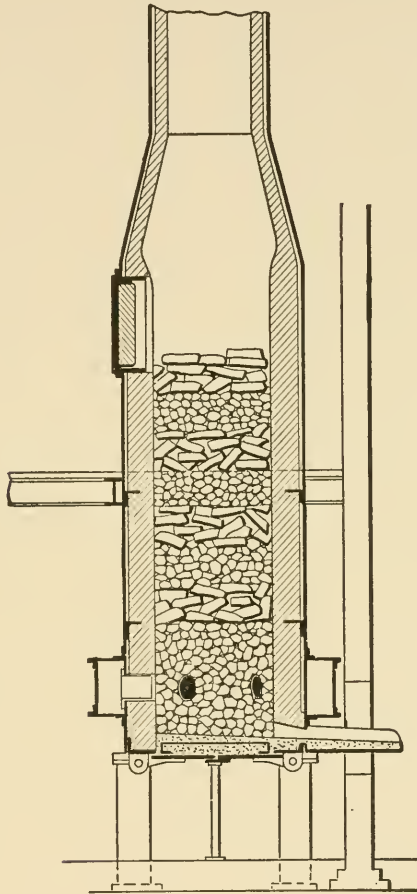

FIG. 77.

shows through at the top of the bed. Iron and coke should be charged successively until it is at the height of the charging door. Succeeding charges are put in as fast as the preceding charges settle away from the charging door. The charge within the cupola is kept to the height

of the charging door until the entire amount to be charged has been put in. This is so that the descending charge may take up as much of the heat of the escaping gases as possible, so that the iron may be near the melting-point when it descends to the melting zone. The charge of coke on the bed must be of an amount that will hold the iron at the melting zone of the cupola until it is all melted. Each succeeding charge should be of the amount necessary to melt the charge of iron placed upon it. The first charge of iron may be much larger than the succeeding charges, but must not be so large that part of it passes below the melting zone before it is melted.

The weights of the charges for a 26-inch cupola are as follows: On first charge, 390 pounds of coke on bed, 1170 pounds of iron. On each succeeding charge, 50 pounds of coke, alternating with 450 pounds of iron.

The smallest heat that may be taken from a cupola consists of the bed charge and one succeeding charge. The largest heat is that which may be run off before the tuyères become clogged so that the melting stops. For long heats, a flux should be charged with the iron, which forms a slag of the refuse in the cupola and makes the slag more fluid. The slag is removed through the slag notch, which clears the cupola, allowing it to run longer without stopping up.

In order to produce a soft iron for machinery castings, mix 1 part of soft foundry pig iron with 4 parts of machinery scrap iron.

In using limestone, marble, or shells, the flux is charged with the iron in an amount of 30 to 50 pounds to one ton of iron.

The **tapping out and stopping up** of a cupola must be accomplished while the blast is on. After the fire is lighted, the breast, or port hole and the tuyères are left open to supply air to the fire until the blast is turned on. The fire should be started early enough to allow the wood to burn out and the coke to become well ignited before the blast is turned on. As the blast is started, the covers over the tuyères are closed, leaving only the port hole open. This is kept open until the molten metal appears, when it is closed with a clay ball.

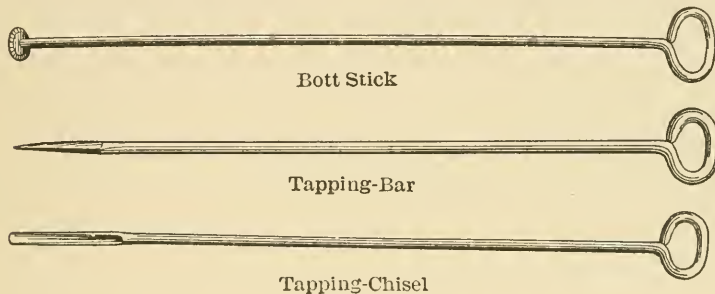

FIG. 78.

The blast is allowed to blow through the port so as to burn the coke lodged in it and ensure a free passage for the first tap. After the metal appears it will keep the coke and refuse out of the tapping hole. The fire blowing through the port heats it to prevent the chilling of the first iron that enters it.

The tools used for tapping and stopping up a cupola are shown in Fig. 78. The bott stick is for stopping up the cupola by placing a clay ball upon the disk end to close the port. The tapping bar is used for tapping out or removing the clay ball which has become baked in the port. The tapping chisel is used when iron or encrusta-

tions have frozen about the tapping hole so that the bar cannot remove them.

In stopping up the cupola, the bott stick should be directed downward into the port, so that the clay is pressed into the hole before it dries on the face by contact with the metal. When the bott stick is forced against the stream of metal, it washes away or forms a crust which will not unite with the edges of the hole, therefore it will not stop the flow. The clay ball must hold the pressure of the blast and that of the metal head acting against it.

Where long bott sticks are necessary, a light and stiff one may be made of a tube whose ends are drawn, so that a handle is welded at one end and a rod bearing the disk at the other. A soft wood bott stick having a metal end on which to place the ball gives good service and is light to handle.

The clay for stopping a cupola must be capable of bearing the pressure and still not bake so hard that it can not be broken away with the tapping bar. A mixture for forming the clay balls is 1 part sand to 3 parts of good clay, then 1 part flour to 10 parts of the mixture. This will bake as a core for holding the metal and after drying it crumbles away easily before the tapping bar.

Furnaces of the **reverberatory** type are now used only where it is important to have the iron of a particular quality or chemical combination. For chilled work and castings for malleablizing, the reverberatory furnace has some advantage over the cupola. The fuel required for melting a given amount is about double that of a cupola. Soft and cheaper fuels may be used.

In this furnace the fuel is burned upon a grate and the metal is held in a separate division where it is not in contact with the fuel. The process of melting is slower, and the molten metal may be retained in the furnace until its chemical condition is that desired. Test may be made

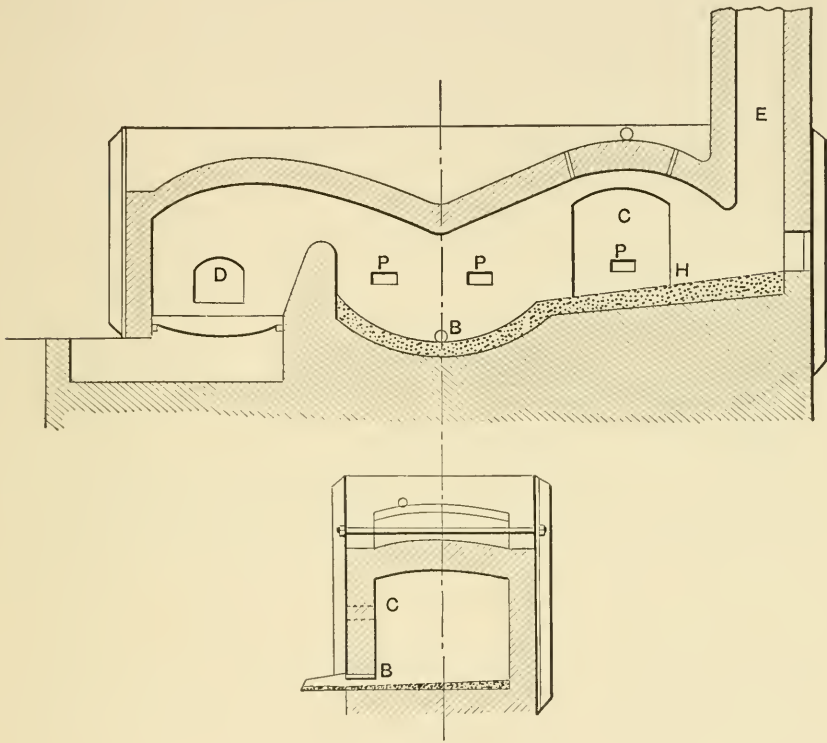

FIG. 79.

of the accumulated metal, and when the carbon is in the proper condition the metal may be tapped out and cast.

The two general forms of furnace are shown in Figs. 79 and 80. In the furnace represented by Fig. 79, the bath is immediately behind the bridge, while that shown

in Fig. 80 has its bath at the end remote from the bridge. The fuel is placed upon the grates through the opening D. The charging door is shown at C, which is a cast-iron door lined with fire-brick. The hearth at H is where the metal is placed when charged. P shows the opening or peep holes through which the process of melting may be seen or the working of the metal effected. The tapping hole is shown at B at the bottom of the bath.

The bed or bottom of the furnace is made similar to that of a cupola, using the same mixture or one that is

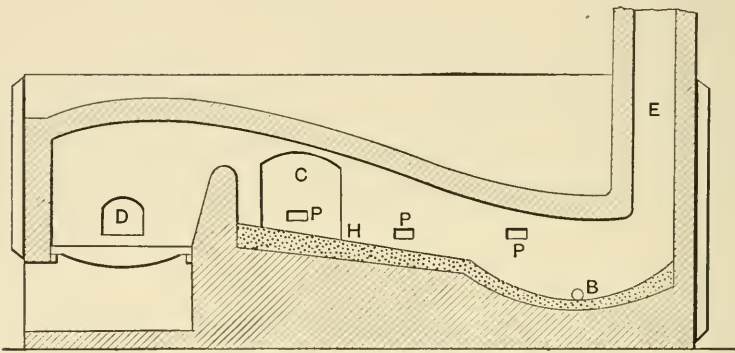

FIG. 80.

more open. This bed will last for eight to ten heats, if it has been well dried before the first charge is placed upon it. The walls and roof of the furnace are made of the most refractory kind of fire-brick, using care to have close joints and all crevices carefully sealed to ensure proper working of the furnace.

When iron is in a molten state, the presence of oxygen will affect the carbon in the iron and burn out the graphitic carbon, making it harder and more brittle. The special object of using a reverberatory furnace is to

obtain an iron having its carbon in the form desired, hence it is very important that cold air or oxygen should not strike upon the metal. The openings must be closed except when necessary to assist the working of the furnace. The entire charge for the heat must be placed upon the hearth before melting begins, because the furnace is so cooled and the metal acted upon by the cold air when a new charge is put in that it cannot be brought back and the charge melted before the iron in the bath is too cold for use. It is similarly of importance that an even fire should be maintained and that no holes be caused by cleaning or raking the fire, thus avoiding the entrance of air to the furnace through the fire. The pressure of the blast should be that necessary to maintain a rapid fire with complete combustion. The usual pressure necessary is from 6 in. to 7 inches of water column.

The iron should be charged onto the hearth so as to leave openings between the pieces. The first layer should extend lengthwise of the furnace and each succeeding one should lie across the preceding layer. The melter may often hasten the process of melting by separating the pieces or by breaking apart those that tend to weld. The molten metal is skimmed, as the accumulation of dirt or scum shields the surface from the direct action of the flames and thus the furnace loses its efficiency. When various brands of iron are charged into the furnace, the metal is mixed by the process of "boiling," or "polling the metal." This process usually consists of thrusting green wood into the metal, causing a violent ebullition throughout the mass, ensuring a homogeneous product. After all the charge is melted and the iron is white-hot,

the melter dips a sample from the furnace with a small hand ladle for testing. If found satisfactory, the mass is boiled or polled for about five minutes, then the damper in the flue is closed and the furnace tapped. The iron should then be poured immediately, as it will change in



FIG. 81.

the ladles. All the operations in the furnace are conducted through the openings or peep holes, and are performed as quickly as possible to avoid keeping the holes open longer than absolutely necessary.

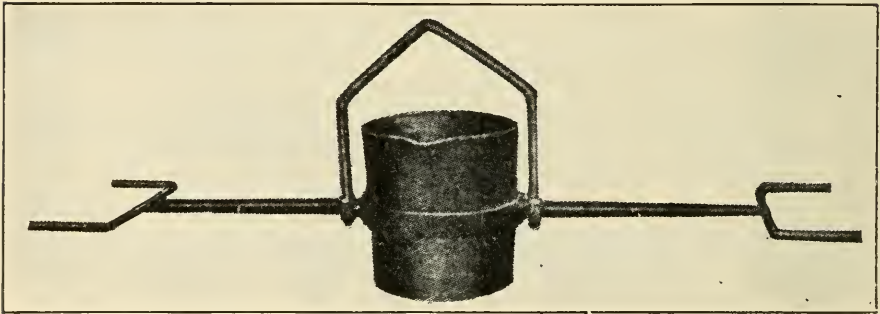

FIG. 82.

The vessels in which the molten iron is handled are called **ladles**. They are generally divided into four classes. Hand ladles shown in Fig. 81 are handled by one man and hold up to 50 pounds of iron. The bull ladles are those having a double shank and are carried by two or more men. Such a ladle is shown in Fig. 82

with the bail removed, or, similarly in Fig. 111, having the straight shank on one side. These ladles hold from 75 to 350 pounds of iron. The crane ladles are all those handled by use of the crane. There are two general types, those having the fixed shank with bail, as in Fig. 82, and those having the gearing, as in Fig. 83. The fourth type of ladle is used only in special places where

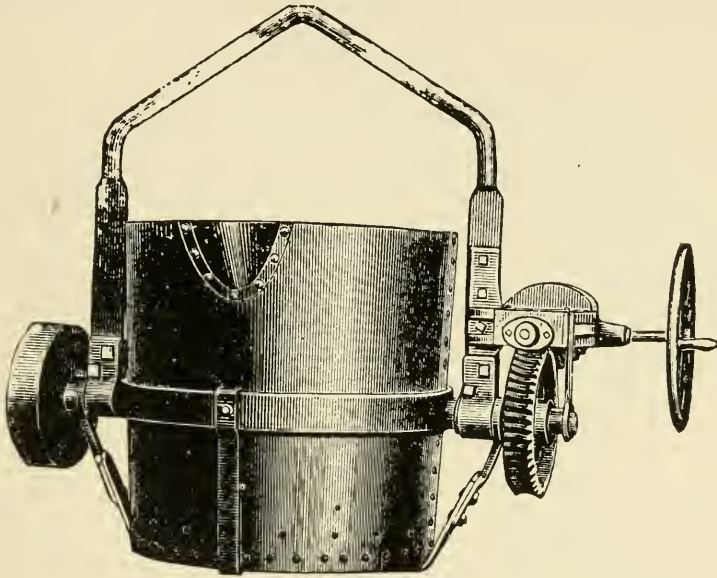

FIG. 83.

suited for such use. These are mounted on wheels and are known as truck or car ladles, as shown in Fig. 84. They are used for delivering the iron from the cupola to a crane ladle or to the floors where it is to be poured.

The ladle is made of sheet iron riveted together, and must be lined with clay or fire-brick to withstand the heat. The clay used may be about one part sharp sand to four parts pure clay. When the clay itself contains sand, the sharp sand may be reduced. The lining

is put on evenly from one half to three quarters inch thick and dried. The cracks are filled with thin clay

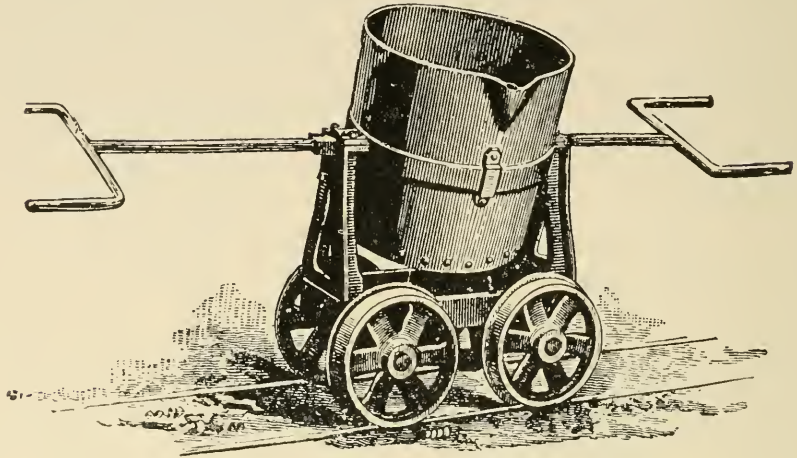

FIG. 84.

and again dried to ensure a solid surface. The large ladles, as for the crane, are lined with fire-brick laid

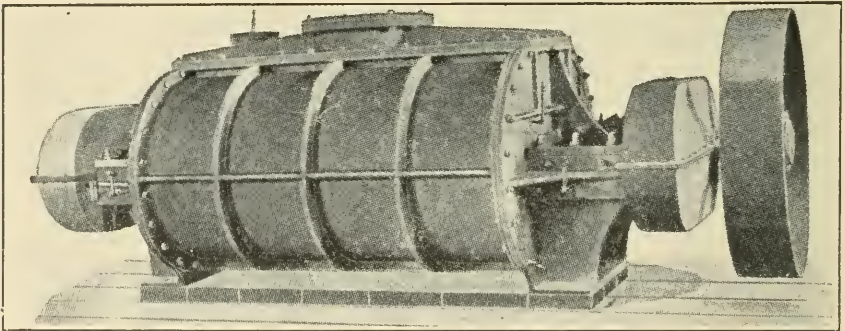

FIG. 85.

up in fire-clay, as in the case of the cupola lining. A daubing of clay is placed over the fire-brick to take the cutting and wash of the iron. The daubing is put

on the same as the lining of the smaller ladles. In receiving ladles for the cupola, the continual fall of the iron upon one point as it comes from the spout cuts away the lining very rapidly. Without special protection the lining will be cut away in a comparatively short time. A good method of daubing this ladle is to have the place where the metal strikes built up with small pieces of fire-

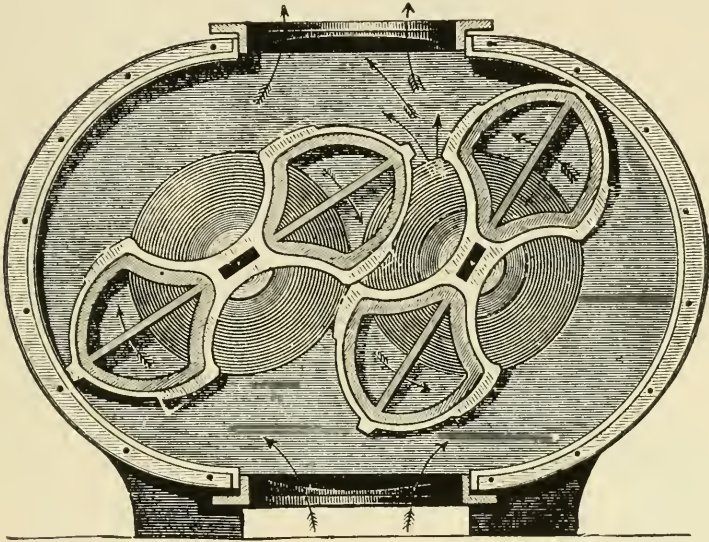

FIG. 86.

brick laid into the clay very closely, and the mass well bound together with the clay daubing and thoroughly dried before the metal strikes it.

The blast for melting the iron is produced by **blowers** suitable to deliver the volume of air desired and to maintain the pressure required for the particular furnace. There are two types of blower in general use: first, the **positive blast** or root blower, and second, the **fan**.

Fig. 85 illustrates one style of a root blower which is

driven by a belt. The blast is produced by the rotation of the vanes, as indicated by the arrows shown in the sectional view in Fig. 86. These blowers are positive,

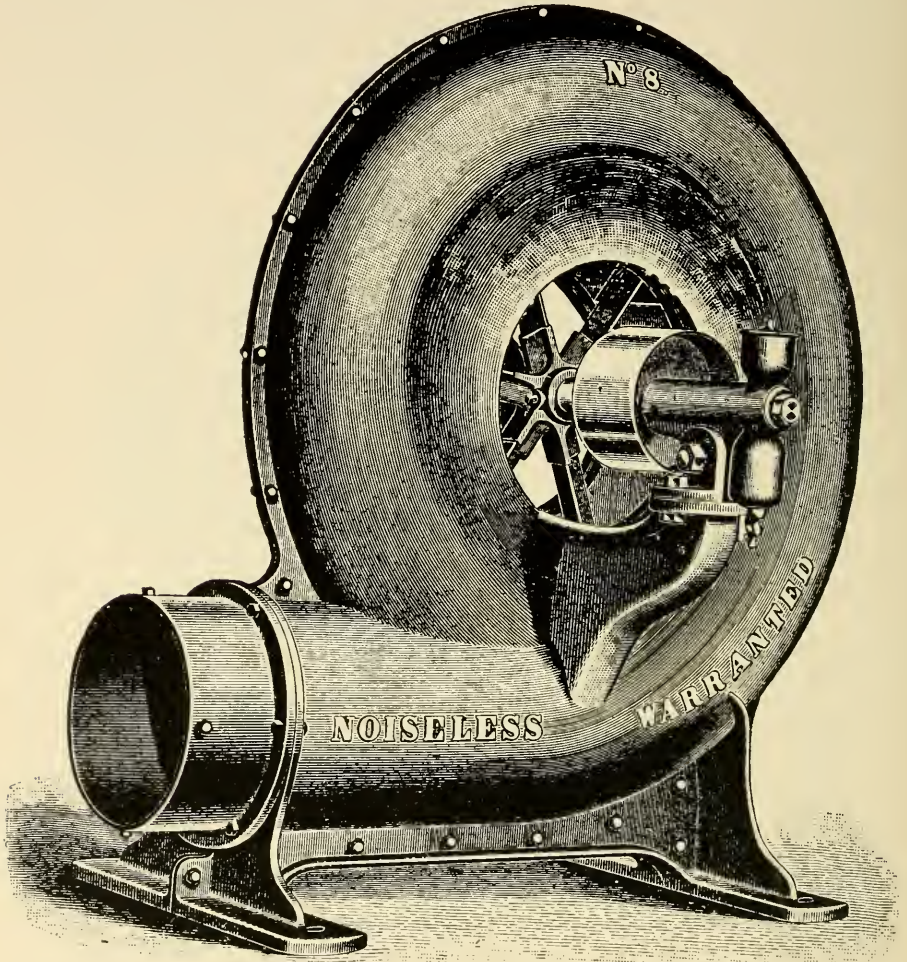

FIG. 87.

because the volume of air delivered at the discharge side cannot escape back between the vanes to the admitting side, even if the pressure is increased in the discharge

pipe. A relief valve is usually placed on the discharge pipe which relieves excess pressures.

Fig. 87 shows one form of fan blower which is driven by belt. The blast is produced in these by the centrifugal force given the air at the end of the vanes and acting tangentially to the rotation of the fan, thus discharging into the delivery pipe. The air supply is taken in at the centre, which is left open. When the pressure in the delivery pipe becomes equal to the centrifugal force produced by the fan, the air will not be delivered into the discharge pipe, hence no further increase of pressure.

Either of these blowers may be directly connected or may be driven by ropes or belts.

CHAPTER VI

CHILLED CASTINGS

IN many castings it is desirable that parts of the surface shall be very hard, to withstand wear and tear, while other parts shall retain its general toughness or shall be of soft iron. This result is effected by **chilling** the portion of casting desired to be hard. The chilling is accomplished by placing an iron **chill** in the mold where chilling is desired, while the other portions of the mold are formed of sand as usual. The metal coming in contact with the iron is cooled quickly and holds the carbon in the combined or white iron form, while the parts cooling more slowly allow the carbon to change back to the graphitic or gray iron form, which is soft and tough.

This method of hardening parts of castings is used for many forms of casting and under various conditions. The most extensive use is that of chilling the rim of car wheels and the face of rolls.

The sand parts of the mold are made similar to other castings, either in green or dry sand, as the case may require. The chill portions are placed into the mold as a third part to the flask, as in car wheels and rolls, or are set similarly to a core in the side of small molds, as machine parts, anvils, etc. The chill is heated in an oven to a temperature of about 200° F., before placing in the

mold. The moisture from the mold and from the sand adjoining the chill would be deposited on the surface if it were cold, thus causing it to blow and to force the molten iron away from it when cast. After warming, the face of the chill must be coated in order to prevent the iron from sticking to the surface and to allow the chill to be lifted from the surface. A coating of blacking wet with molasses water gives good satisfaction. Other methods of coating that work better in particular cases are: to shellac the face and allow to harden well before using; to varnish the face with a common grade and when nearly dry sprinkle with plumbago; or to use a thin coating of a light clean oil, as a heavy oil or a thick coat will burn off, thus holding the iron away by the gases formed.

The chill should be so placed in the mold that the metal shall rise on the chill but shall not lie horizontally or have the inflowing metal fall upon the chill. The gates should be so arranged and of such a size that the chill will be covered quickly to prevent the metal forming bubbles on the surface of the chill. It should be flushed up quickly, or the chill will cause cold-shots and streaks in the chill surface.

The metal in contact with the chill forms a crust or shell quickly and contracts, holding the remainder of the iron while still in the molten state. If there is any unevenness in the pressure on this shell, it may cause cracking or bursting of the surface, as is sometimes noted in chilled faces. This may be lessened by having the flask so arranged that the chill is level, as in rolls or car wheels.

The chill should be made of the best grade of iron

having little contraction, so that the surface will not check and break when the face is suddenly heated by the molten metal. A good iron for making chill casting will make a good chill. Wrought iron is sometimes used for a chill. The thickness of the chill is much dependent upon the depth that it is desired to chill the casting. It must be of such a size that it may conduct away the heat necessary to cool the iron from the molten state, about 2500° F., to that of solidification, about 1000° F., and must hold it at that temperature so that the iron within will not remelt the chilled skin. Special types of chill for car wheels are in use which give good results. They are made up of parts instead of a solid ring, and some forms are so arranged that the chill contracts as the casting contracts, thus following the surface of the castings as it cools. Another form has open chambers through which steam is circulated to warm the chill before casting, then cold water is circulated after casting, to effect a deeper chill. The depth of chill is dependent upon the mixture of iron used and the rapidity with which the face of the casting is cooled. The depth of chill on rolls varies from one half inch to seven-eighths inch to suit different requirements. Some users of rolls desire a defined chilled skin while others wish the chilled portion to shade gradually into the soft interior of the casting. Car wheels are chilled to a depth of about three fourths of an inch.

The mixtures of iron for chill castings can be successfully made only by use of chemical analysis, and not by judging from the fracture. Good soft iron should have 1.8 per cent silicon; while this will not chill without

excess of sulphur, which makes a very poor iron. Chill iron should have less than 1 per cent silicon and not over 0.08 per cent sulphur. The total carbon should be as high as possible, other metalloids being constant. The combined carbon should rarely exceed 0.6 per cent, as that makes the iron too hard and too brittle. The mixtures must be closely watched and tested every day to ensure the proper proportion of impurities. Iron melted in a cupola is tested before pouring into the chill molds. The test is for depth of chill, and the test bar is about 2 in. square and 6 in. long, having one side against a chill. It is cooled and broken, and if the chill is insufficient it is poured into other molds or pig beds where it may be remelted. The air or reverberatory furnace has many advantages for this class of work, as the iron may be tested and varied by addition of special irons before tapping for the purpose of pouring.

CHAPTER VII

MALLEABLE CASTINGS

Malleable cast iron is a form that becomes tough and partly malleable when annealed by the malleablizing process. The iron loses its brittleness and may be bent or straightened without breaking. Thus it may better resist shock and occupies a place between gray iron and wrought iron, having a higher tensile strength than the former and less ductility than the latter.

The effect of the malleablizing process is to change both the chemical composition and physical properties of the iron. The most important of these changes is to convert a large part of the carbon, which originally existed in the combined form, into a special variety of the graphitic form. This variety does not occur, as ordinarily in plates, but in a much finer state of division. In practice, the percentage of total carbon as well as other metalloids is somewhat reduced. The results of these changes are to make some of the physical properties of the casting resemble those of wrought iron.

The iron used must be a white iron whose carbon will be in the combined form. The percentage of silicon must be low. When above 0.75 per cent, the metal will have a high tensile strength but small elongation. The fracture has a steely appearance in the finished casting when

the silicon is too high. Phosphorus is beneficial up to 0.15 per cent, as it helps maintain fluidity in the metal. Sulphur is very detrimental when present in appreciable percentages. An iron having sulphur or phosphorus too high will be harder and have cracks at the surface of the casting. The presence of manganese in comparatively high percentages is beneficial to the resulting casting. It acts as a neutralizer on the silicon to prevent its effect upon the carbon. Manganese assists the carbon change, and shortens the time necessary for its completion. Scaly castings, when properly packed, result from too low a percentage of manganese.

The process of annealing is effected by packing the castings with oxidizing reagents into covered cast-iron boxes. They are placed in ovens which are sealed and heated by some form of direct-fired furnace which holds the temperature uniformly at about 1850° F. for a period from eight hours to several days, dependent upon the size and character of the castings. The ovens are so arranged as to distribute the heat evenly and not to be subjected to sudden changes. The temperature is measured by a pyrometer which will indicate the high temperature. Too high or too low a temperature affects the action of the reagents and injures the resulting castings. The oven is heated slowly so as to maintain the temperature of the castings at nearly that of the oven at all times, and is cooled very slowly when the process is complete, to avoid a chemical change due to the sudden change of temperature. These ovens may be fired by coke, coal, oil, or gas.

The reagents used must be high in oxygen, which at

the temperature of the annealing will combine with the carbon of the iron forming CO gas, which passes off. Some of the reagents used are red hematite ore, rolling mill scale well oxidized or rusted, and steel turnings heavily rusted. The oxidizing may be effected by a weak solution of sal-ammoniac. These may be used several times by the addition of a partly fresh unburnt reagent. or by reoxidizing with sal-ammoniac each time. The casting must be completely covered with the reagent when packed in the boxes. If two castings touch, those spots will not be properly malleablized, thus making an imperfect casting.

The form and proportions of the pattern for malleable work require special attention. Sharp angles must be avoided and all corners filleted with adequate radii. The iron always shrinks away from the angle in both directions, thus causing a crack or depression, which should be avoided. The change from light to heavy section should be gradual. The round section has proved to be the weakest form, hence it should be avoided. As the greatest strength of malleable castings lies in the skin, it is preferable to have as great a surface as possible with no great thickness of metal, as in many cases it is preferable to have several thin ribs rather than one thick one.

The gating of castings to be malleablized is of great importance and requires the most skill and experience of any part of the work. For this reason most patterns have gates attached which are put on by experienced men. The cause of difficulty in gating a casting or running intricate forms, as in gray iron, is the hardness of the iron, causing it to shrink more and set more quickly. The

branch gate should not extend from the bottom of the feeder, as it will chill from the sand, thus solidifying sooner than the metal in the mold. The feeder should extend about one-third its length below the branch gate and should be as close as possible to the casting. For light patterns the branch gate should not exceed half an inch in length, and it is preferably of circular section. When it is difficult to feed a portion of a mold properly, a chill may be placed at that point to solidify it more quickly than the other parts, thus preventing fracture or shrink-holes.

CHAPTER VIII

CLEANING CASTINGS

WHEN the casting comes from the mold it has more or less sand adhering to its surface, or the cores are still in the casting. It must be **cleaned** and all sand removed

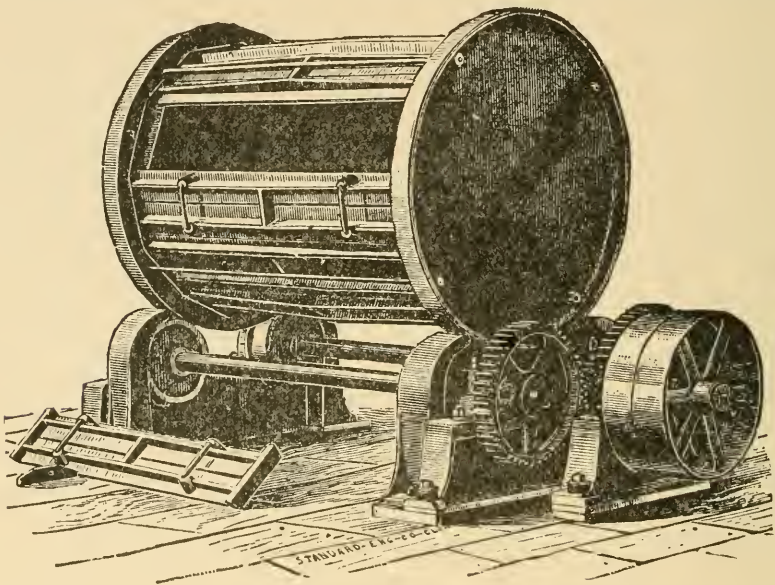

FIG. 88.

before it is ready for the machine shop. The gates and risers, as well as all fins, should be **chipped off**. This is a portion of the cleaning and of the preparation for leaving the foundry. The methods of cleaning the sand from

castings may be classed under three main heads: First, the use of tumbling barrels; second, hand work; third, the use of pneumatic appliances. The tumbling barrel,

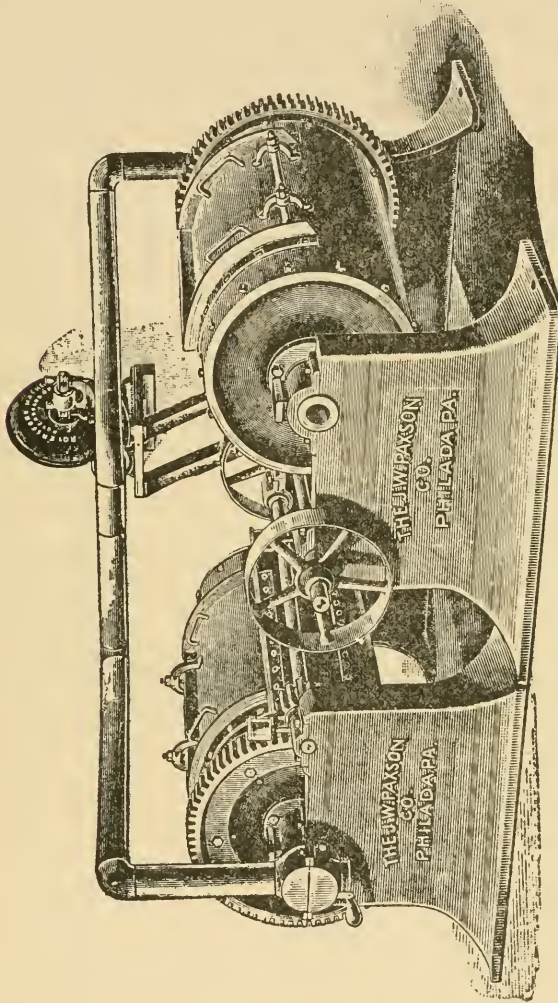

FIG. 89.

or rattler, is driven by power and cleans the castings by their rolling about in the drum as it turns over. Fig. 88 represents a tumbling barrel driven by the friction wheels on which it rests. Fig. 89 shows a pair of tumbling

barrels driven by gears and having the exhaust connection for drawing away the dust as it is freed from the castings.

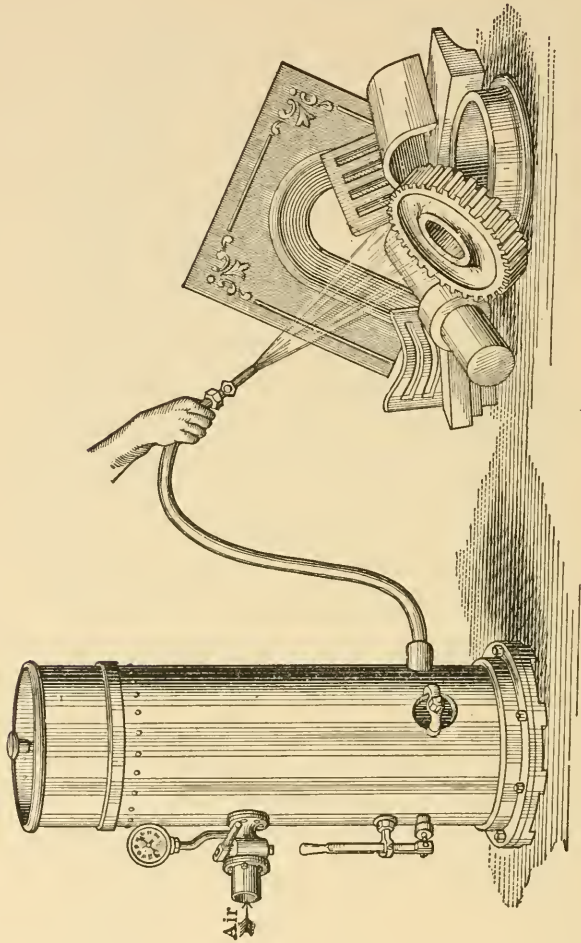

FIG. 90.

The cleaning by hand is chiefly done by use of wire brushes and emery bricks, or rub-stones. When the sand is fused hard onto the casting, it may require chipping, filing, or scraping with iron scrapers. The use of pneumatic appliances for foundry work is increasing rapidly.

The greatest convenience for cleaning is found in the sand-blast appliances, as represented in Fig. 90; also as connected to a tumbling barrel having an exhaust connection. The sand blast is attached to the tumbling barrel at the centre opposite to the exhaust pipe. This gives the action of the sand blast upon the castings as they move about in the tumbling barrel.

The gates, risers, and fins on castings are removed, in general, by hand chipping, or by the use of a pneumatic hammer shown in Fig. 95. When the gates on castings cannot be broken and chipped without danger of breaking into the casting, it is sawed off or ground off on an emery wheel. Many shops are equipped with cold saws for this purpose. All shops making steel castings must be provided with cold saws of some type, because the gates and risers must be so large that it is impossible to chip them off without danger of spoiling the casting. The emery wheel is used extensively on small castings and for smoothing over the chipping on other castings. The fixed wheel of a coarse grade is generally used. The portable emery wheel, or grinder, is very convenient for large castings.

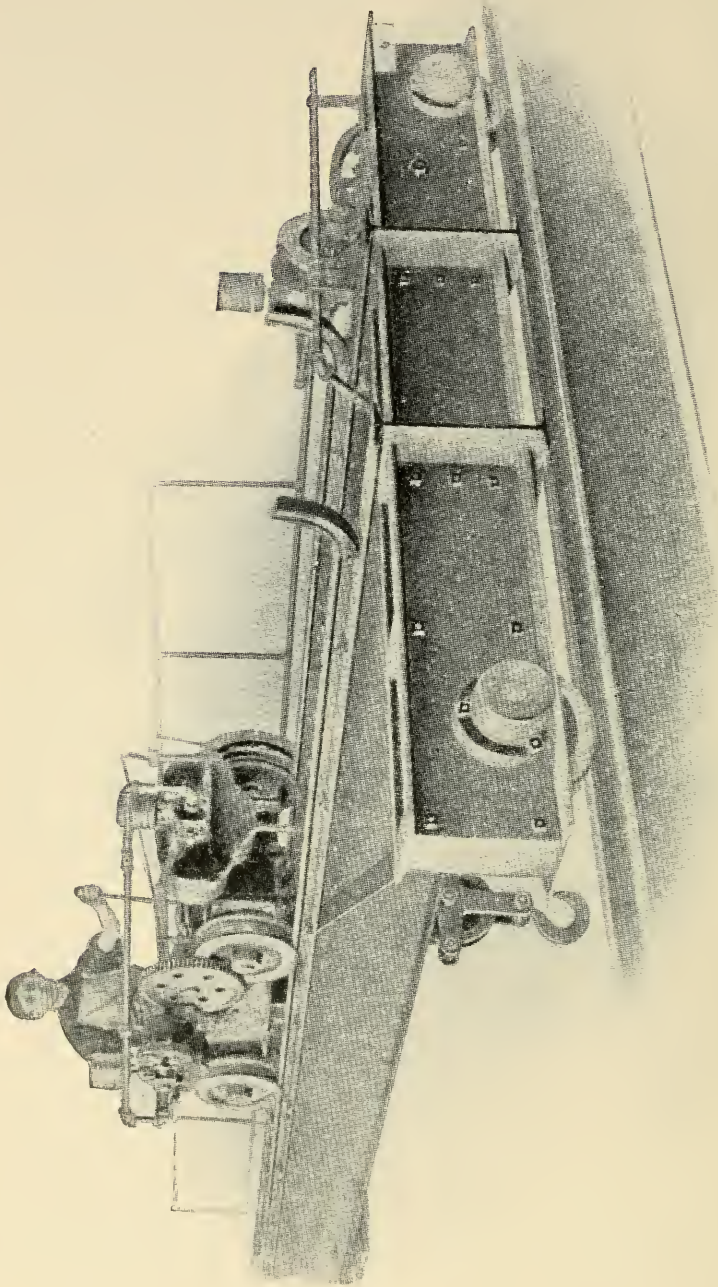

FIG. 91.

CHAPTER IX

COMPRESSED AIR FOR FOUNDRY PURPOSES

THE use of **compressed air** in a modern foundry is considered indispensable. By use of pneumatic tools and machinery the cost of foundry products is greatly reduced. The appliances operated by compressed air are the pneumatic crane, hoist, molding machine, sand sifter, chipping hammer, screen shaker, sand rammer, and sand-blast machine.

The **pneumatic crane** is shown in Fig. 91. All movements of the crane are controlled by the operator in the carriage.

The **pneumatic hoist** is shown in Fig. 92. In lifting copes and drawing patterns, the most perfect and regular motion is required to prevent "sticks," "tears," and "drop-outs." A jerk is fatal to the mold. This hoist may be moved with a speed as slow and as regular as the hour hand of a clock, and a change of speed may be made without a sudden jerk or jar. It may be operated rapidly as well.

A **pneumatic molding machine** is shown in Fig. 93.

The **pneumatic sand sifter** is shown in Fig. 94. This machine is operated by an air cylinder directly connected to the sifter. The air is supplied to the cylinder

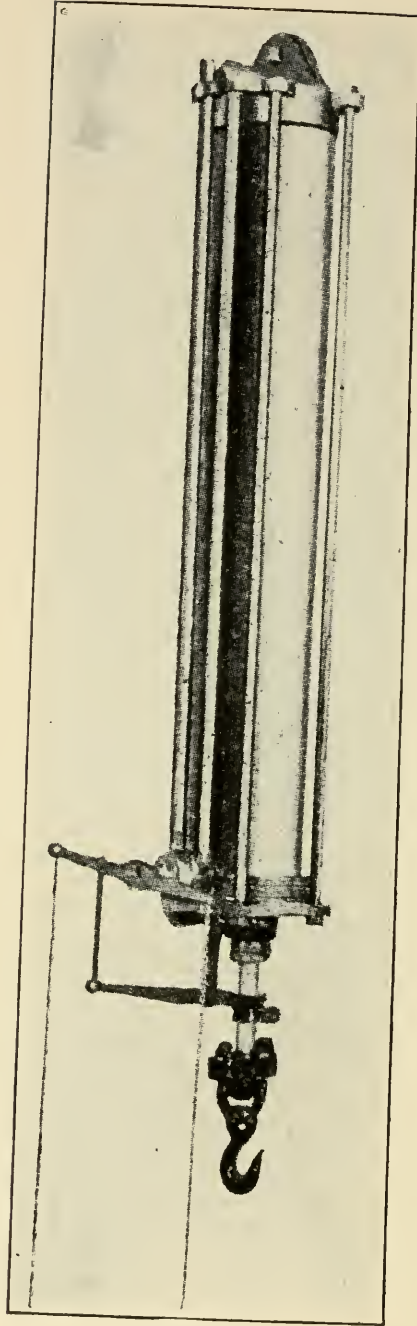

FIG. 92.

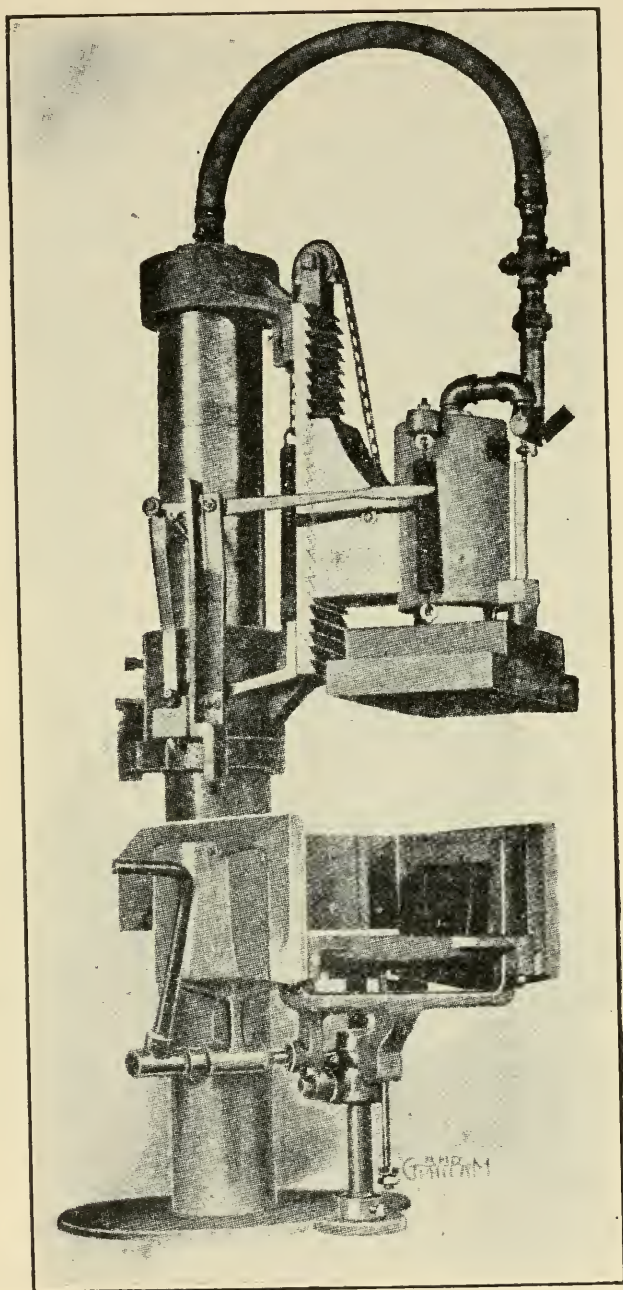

FIG. 93.

by a rubber hose, making the machine portable so that it may be used in any location in the foundry.

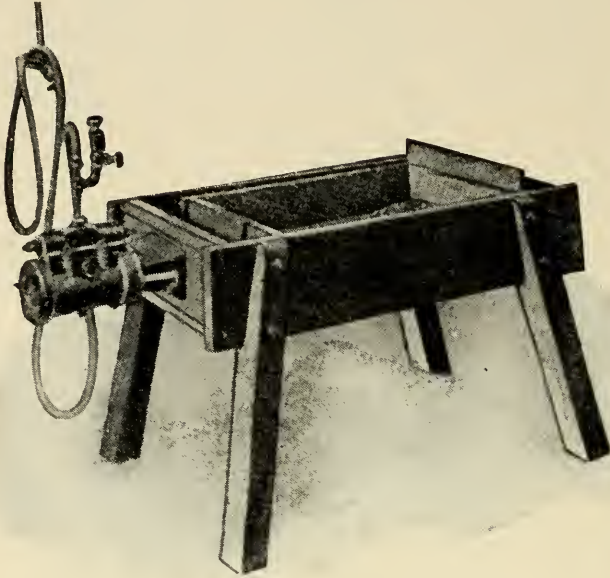

FIG. 94.

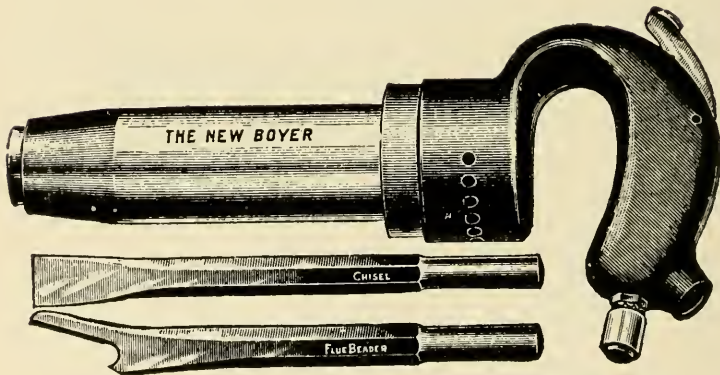

FIG. 95.

The pneumatic chipping hammer is shown in Fig. 95. The pneumatic sand rammer in Fig. 96 is fitted to

hang from a support, and has both pein and butt as the operator may desire.

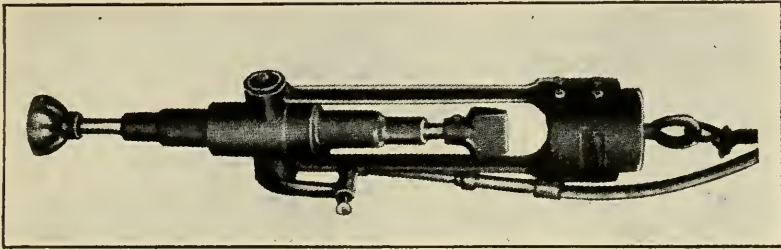

FIG. 96.

The **sand blast machine** is shown in Fig. 90.

Fig. 97 shows a **pneumatic shaker** mounted on a tripod so that it may be placed wherever desired and may

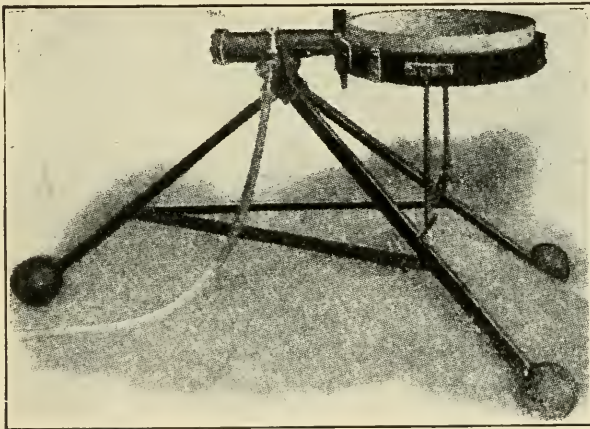

FIG. 97.

be fitted to hold a riddle, so that a riddle of any desired number may be placed in it.

Fig. 98 represents a **pneumatic hoist** having a winding drum driven by cylinders.

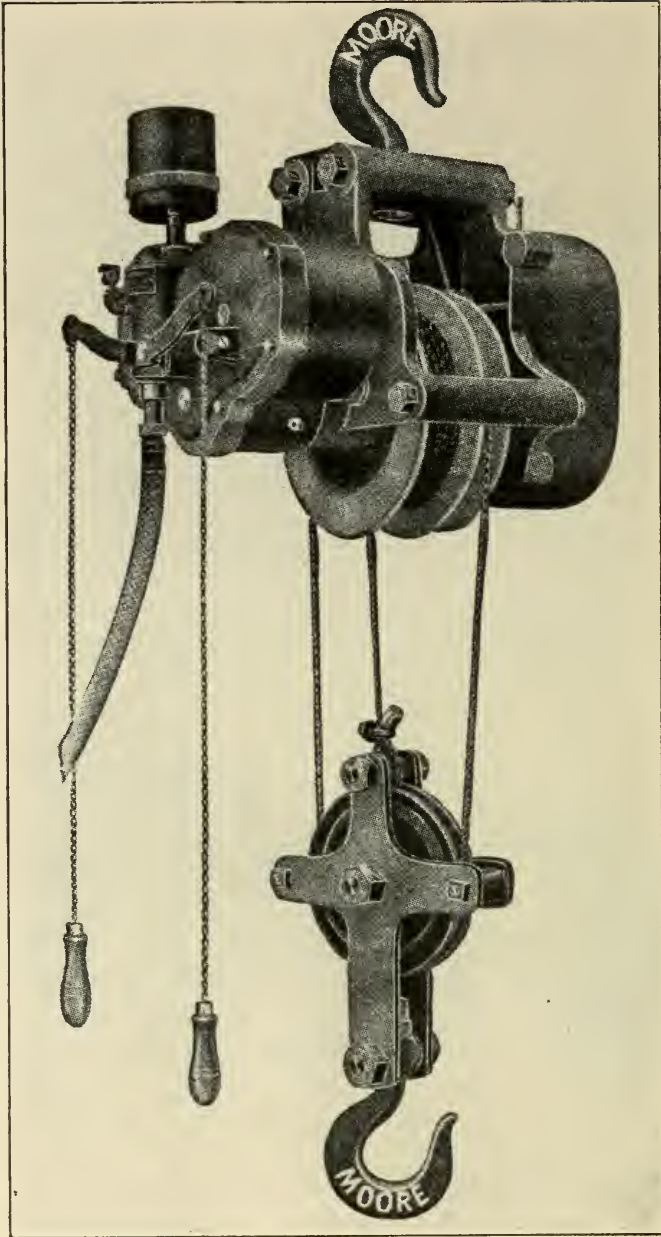

FIG. 98.

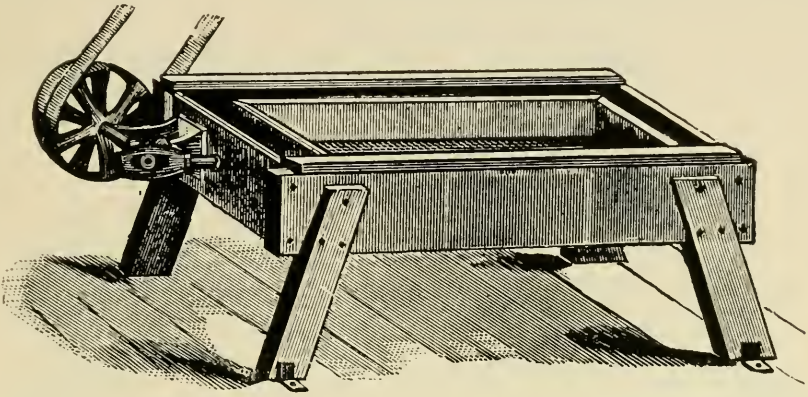

FIG. 99.

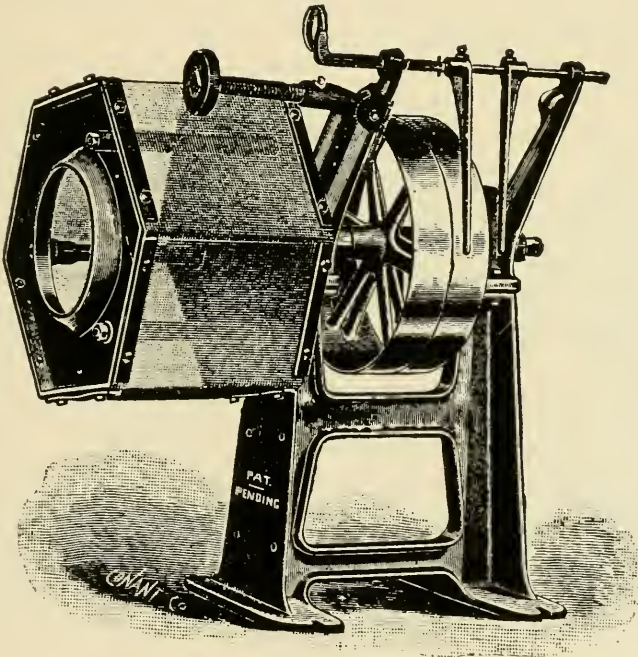

FIG. 100.

The machines shown in figures 99 to 104 represent a few of the special foundry machines. The sand sifter

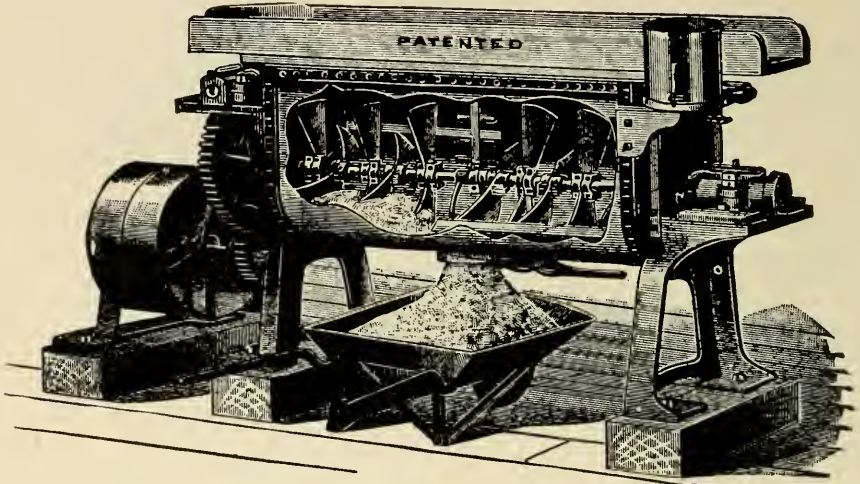

FIG. 101.

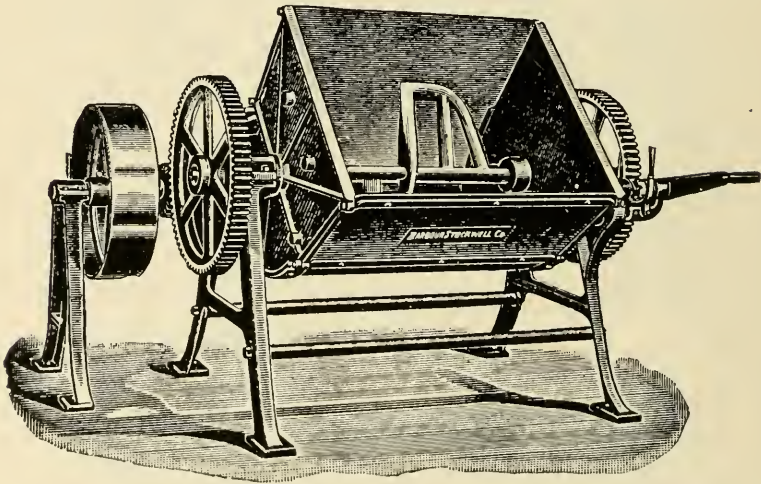

FIG. 102.

shown in Fig. 99 is driven by belt but may be fitted with a hand wheel for hand power.

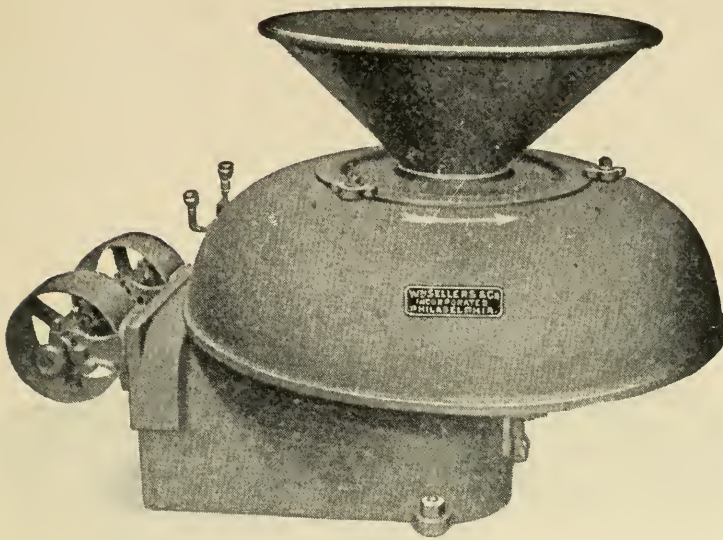

FIG. 103.

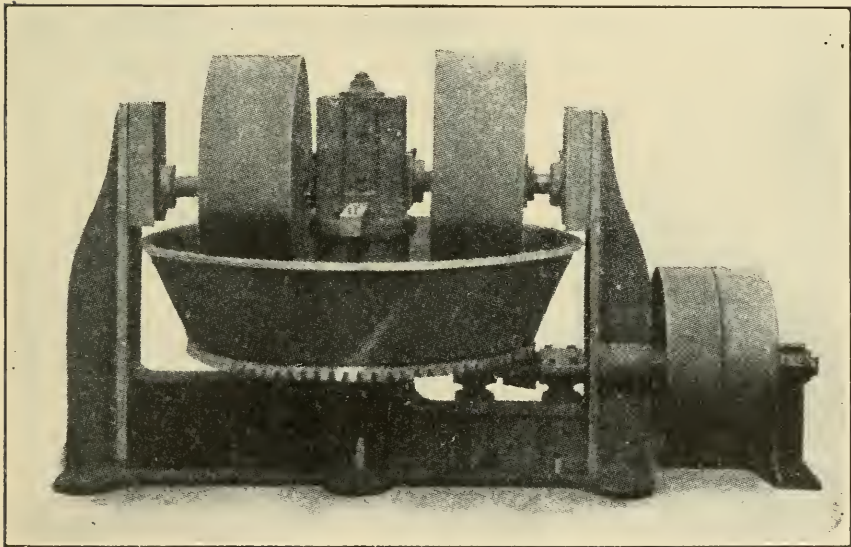

FIG. 104.

Fig. 100 represents a **rotary sand sifter** which is belt-driven.

Figs. 101 and 102 are **sand mixers** having paddles which rotate to mix the sand thoroughly.

Fig. 103 is a **centrifugal mixer**. The sand entering from the hopper falls upon a rotating disk which throws the sand by centrifugal force, thus mixing it.

These mixers are of especial advantage in mixing facings or sands of different kinds where a thorough mixing is necessary.

Fig. 104 represents a **sand crusher**. The pan holding the sand rotates under the rolls and the sand is loosened by fixed paddles between the rolls. These paddles may serve as a mixer also and are used in mixing the sand and clay for the facing of molds for steel castings.

CHAPTER X

STEEL CASTINGS

THE manufacture of **steel castings** is greatly increasing in extent and variety. The industry is young, so that it has not been developed to its fullest extent. A few brief points will here be given which may give the iron worker an idea of methods necessary in making steel castings.

The mold is formed in sand, which may be green or dried to suit the type of work. The same mixtures are used in both cases. The sand is a very open mixture with sufficient clay to form a binder. The following mixture may be taken as a guide: Mix 3 parts coarse sharp sand 98 per cent SiO_2 , 2 parts fine sharp sand 95 per cent SiO_2 , 1 part red clay.

This mixture should be thoroughly blended and crushed in a sand crusher. This is used as a facing while the heap sand from former molds is used as a backing sand.

The mold is rammed very hard, so that in the green form it is nearly as hard as a dry sand mold for iron. The sand is tempered to hold together but is kept as dry as possible. When the mold is dried it becomes very hard and has great strength to resist pressure.

Steel will cut the sand and much more readily than iron.

All edges and projections must be well nailed so that the heads hold the surface of the sand. All large plane surfaces must be nailed quite closely to prevent cutting in the drag and drawing down the cope.

Owing to the hard ramming, the pattern is hard to remove, hence the exact form of casting is not obtained so easily as in iron. Particular forms, as gear teeth, are more difficult to obtain in steel than in iron.

The metal must be of a higher temperature than iron in order to maintain fluidity. Hence it sets more quickly and usually is duller when poured than iron. The gates must be made correspondingly large to allow the mold to fill quickly, or the light or sharp parts will not run. The shrinkage is about double that of iron, and takes place very soon after pouring. A riser must be provided of adequate size to feed the shrinkage. The feeding rod cannot be used as effectively as in iron, hence the riser must act more as a sinking head.

Castings of such form that they crush the sand of the mold when shrinkage takes place are sometimes found to be broken or drawn weak in places when they come from the mold. This is due to the casting being unable to crush the sand to permit the shrinkage. This may be prevented by cutting a gutter on the parting of the flask about two inches from the casting and connecting this gutter by an opening through the cope. As soon as the casting has set the gutter is filled with water, which softens the sand, making it easier to crush. In some cases, castings of quite intricate and large size have been made more successfully in green sand than in dry owing to the mold's resistance to crushing.

The chief methods of melting steel for steel casting are by the cupola or by a converter. Steel is successfully melted in the cupola the same as iron. The higher temperature required offers many difficulties which are a drawback to the process. It is hard to obtain good fluidity in the cupola. The converter gives steel of the composition desired, and the fluidity is much more perfect.

Formerly steel was melted in a crucible, similarly to brass, but this is an expensive method which is not used except in isolated cases. The bottom blow, side blow, and open-hearth converter are the most economical producers of steel for castings. Where the furnace can be kept in operation continuously, the open-hearth furnace presents many advantages. For intermittent heats, the bottom or side blow converter gives the best results. The side-blow converter proves preferable, as the iron used may be lower in silicon and yet obtain a good steel; and besides the steel becomes superheated, which better permits handling and pouring.

In the open-hearth furnace, the metal is melted and reduced in its bath. Any kind of iron or steel scrap may be charged. The product is tested by a sample and is poured when the steel is of the nature desired. The process is slow, taking from eight to twelve hours to reduce a charge.

In the blow converter, the reduction takes place in a very few minutes. The iron for the charge is melted in a cupola and put into the converter in the molten state. The progress of the conversion is told by the gases which pass off at the top. When the desired amount of impur-

ities have been removed, a charge of spiegeleisen is mixed with that in the converter, giving a product of the desired percentage of carbon. The steel may be varied by changing the percentage of spiegeleisen charged. The blast is turned off before charging the spiegeleisen. The two charges in the converter are allowed to mix, then it is poured out ready for the molds.

The iron used for the converter should have about 2 per cent of silicon, phosphorus below 0.06 per cent, manganese as low as possible, and sulphur very low.

The following mixture may be substituted for the ore spiegeleisen: 95 lbs. of ferrous silicate, 45 lbs. of manganese, 65 lbs. of pig iron which is low in phosphorus and high in silicon.

CHAPTER XI

BRASS FOUNDRING

Brass molding is so similar to iron molding that a description is unnecessary. One is different from the other only in the particular that gating and venting must be given more consideration. The sand used for brass molding is much finer, and when rammed in the flask it must be well vented, or unsound castings will result. The metal used in brass casting is of a nature that will not permit an unnecessarily high temperature, as the castings will not then be sound. Long runners cool the metal so as to prevent its filling the mold properly. Short runners and a liberal amount of gating are desirable. The sand most used for brass molding is the Albany. This sand is fine and gives entire satisfaction for ordinary brass work; but for heavy work in brass, and when the casting is to be finished, the mold is made in a coarse and more open sand. Sometimes it is advisable to make the mold in dry sand for heavy work. In pouring the metal into the mold, it should be run as rapidly as possible until the mold is filled. On heavy castings it is very necessary to provide the mold with a riser or shrinking head, as the shrinkage in brass or bronze is greater than in cast iron. After the metal has been cast it may be cooled in water as soon as it has solidified.

By slowly cooling the brass becomes hard, and by sudden cooling the brass may be softened. The immersing in water gives the sudden cooling, and besides removes the sand from the casting.

In preparing the mold for brass the ordinary facings used in iron molds are unnecessary. Plumbago is seldom used except in heavy castings; for light and medium

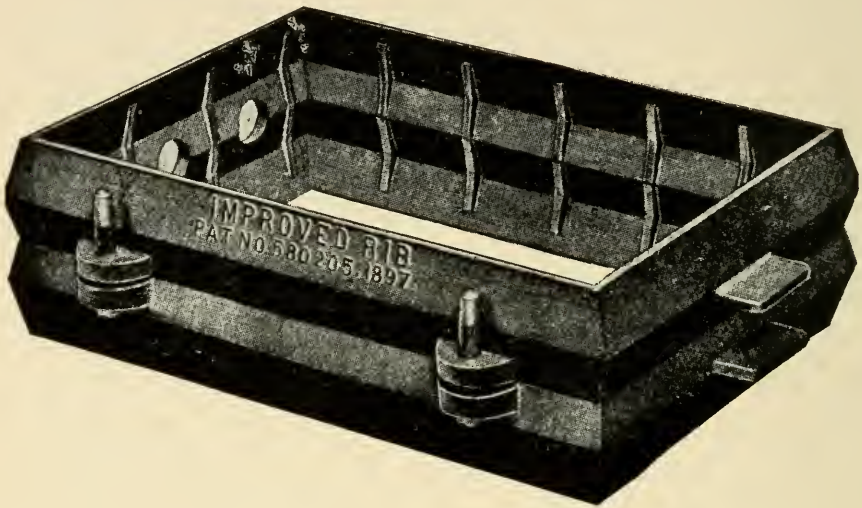

FIG. 105.

work, flour, pulverized soapstone, charcoal, and sometimes plaster of Paris or bone dust are used. In very light castings nothing is necessary except very fine molding sand.

Very good results are obtained in small work by using a very fine sand and spraying the mold with gasoline, lighting it, and allowing it to burn off. This skin-dries the mold and prevents the metal from washing or cutting the mold in pouring.

The snap-flask is sometimes used in brass molding, but for small and for light, thin castings the flask shown in Fig. 105 is more convenient. This flask is provided with openings at one end which are used for pouring-

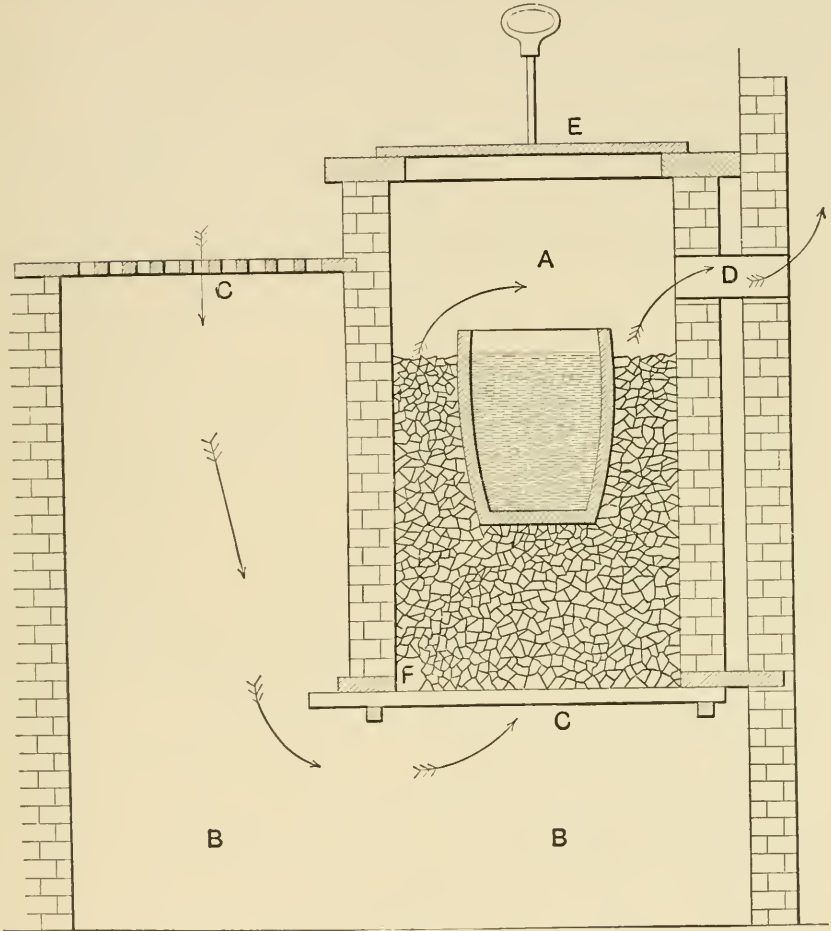

FIG. 106.

holes. When the mold is ready to cast it is set on end with the openings up. This gives more force to the metal and greater pressure in the mold. This also avoids the chilling of the metal before it reaches the mold.

Brass founding differs somewhat from iron founding, for the reason that the metal is of a different character and must be treated differently. Brass, or copper alloys, cannot be melted in a cupola furnace and sound castings

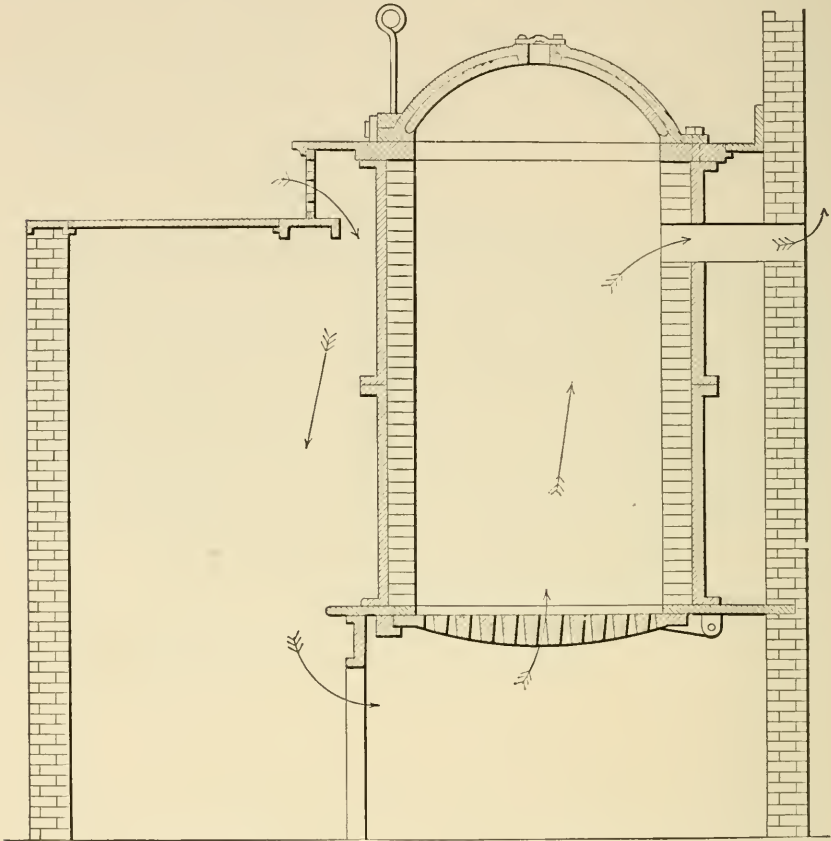

FIG. 107.

be obtained, except in the case of heavy castings with thick metal. The metal coming in contact with the fuel is impregnated with impurities, which causes unsound castings. A simple form of furnace for melting brass is shown in Fig. 106. The more improved furnace is

shown in Fig. 107. To prevent the metal from coming in contact with the fuel, a crucible is used. The crucible containing the metal is placed in the furnace, as shown in Fig. 106. The crucible is handled by means of tongs, as shown in Fig. 108. The furnace is connected with a chimney or smoke stack of sufficient height to furnish draft. Mechanical draft is, however, applied in some cases. The furnace shown in Fig. 107 is supplied with both natural and mechanical draft. This arrangement is best. While the natural draft is cheaper, there are days when the draft is inadequate and the melting slow.

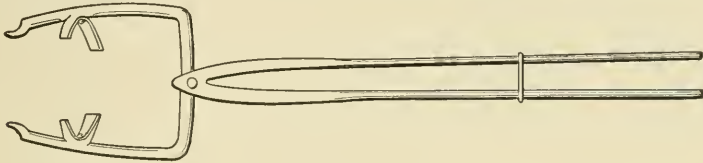

FIG. 108.

At such times, it is desirable to use mechanical draft for faster melting. Foundry coke or anthracite coal is used in this type of furnace.

In Fig. 106 the portion marked A is the fire chamber, B the ash pit through which the air is admitted to the grate C, and D the flue connecting with the chimney or stack. The ash pit in front and underneath the fire chamber is covered by a grating which may be lifted off when it is necessary to remove the ashes from the pit. The fire chamber cover E is provided with an upright handle to enable the operator to remove the cover when the furnace is hot. The fire chamber is constructed of fire-brick and is cylindrical in form. The bottom plate F, which supports the fire chamber, is square, having a

round opening at its centre the same diameter as the chamber. This plate is made of cast iron and is supported in the brick wall at the back and sides of the ash pit. The grate underneath the plate is composed of

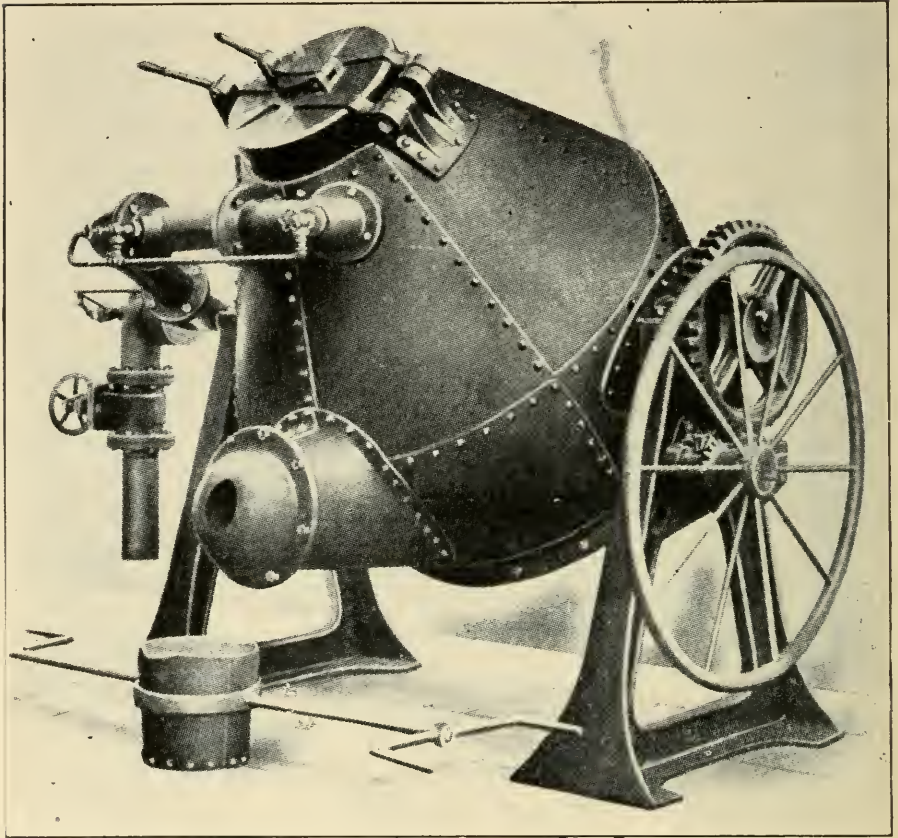

FIG. 109.

single iron bars placed the proper distance apart and supported by cross bars at front and back extending into the sidewalls of the pit. The single bar grate is preferred by many, on account of the convenience in cleaning the fire without rebuilding. After one heat has been

taken, it is desirable to clear the furnace of cinders and ashes which form on the grate. This is difficult to do with the drop gate, as shown in Fig. 107. The single bars may be jarred sidewise with a long bar reaching

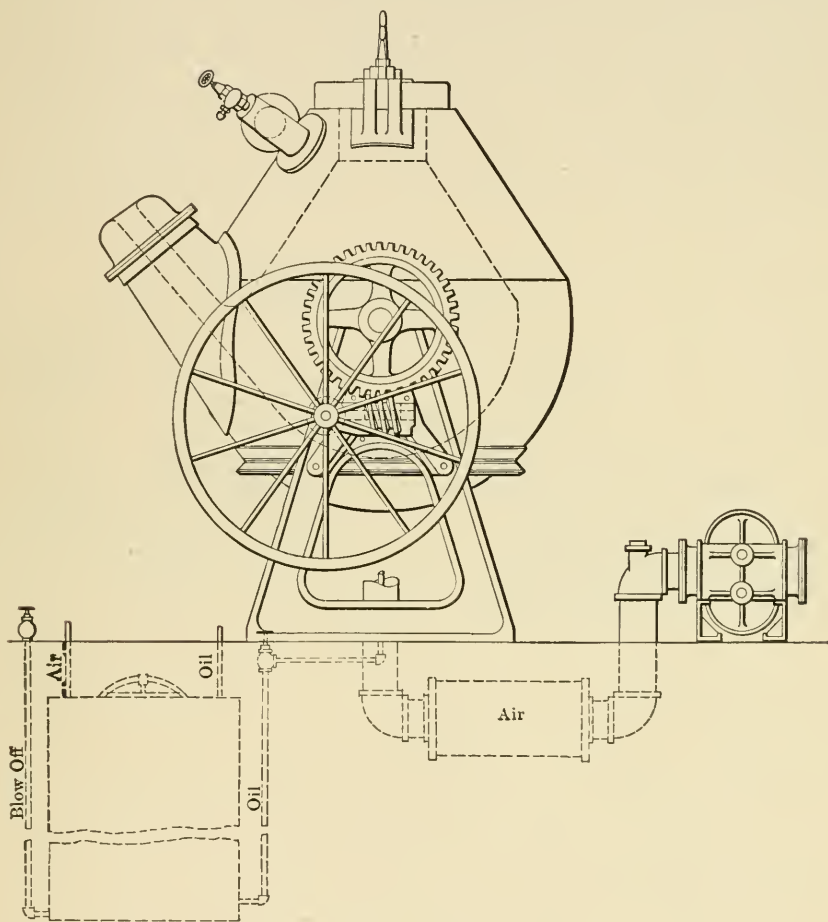

FIG. 110.

through the grating on the ash pit, thus saving much time.

To prepare for melting in this type of furnace, remove the grate bars, clear the furnace of ashes and clinkers,

adjust the bars in their place, put in a sufficient amount of wood to start the coal or coke to burning, and add enough fuel to form a bed 10 or 12 inches in depth. After the fuel is well ignited, place the crucible with metal on the bed of coals and add fuel around the crucible to near its top. As the fuel burns away at the bottom of the furnace, the crucible must be raised slightly and more fuel added around its outside. While this is being done, care must be taken to prevent fuel falling

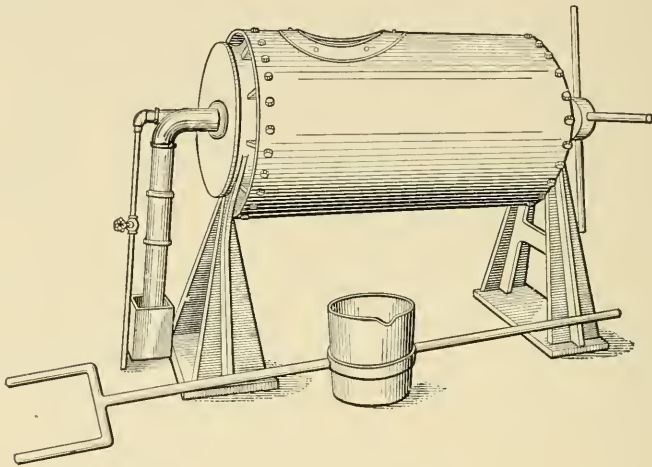

FIG. III.

inside the crucible, as this is a source of damage to the metal. More metal may be added when that in the crucible melts and settles. When the metal has become fluid enough to run well, it should not be allowed to remain in the furnace, but should be removed with the crucible tongs and poured. If allowed to stand, or if overheated, the metal will be damaged.

There are still more modern and improved brass melting furnaces than those mentioned. Among others are

the Schwartz metal melting and refining furnace and the Charlier rolling furnace. These furnaces are heated by fuel oil or gas. They are very efficient and economical on account of rapid melting. The Schwartz furnace is shown in Fig. 109. This furnace is lined with fire-brick and is supported by trunnions having a bearing on pedestals. Air and oil are supplied at an opening through the trunnion at one end. The flow of oil is obtained from a standpipe, by pumping, or by air pressure in the tank.

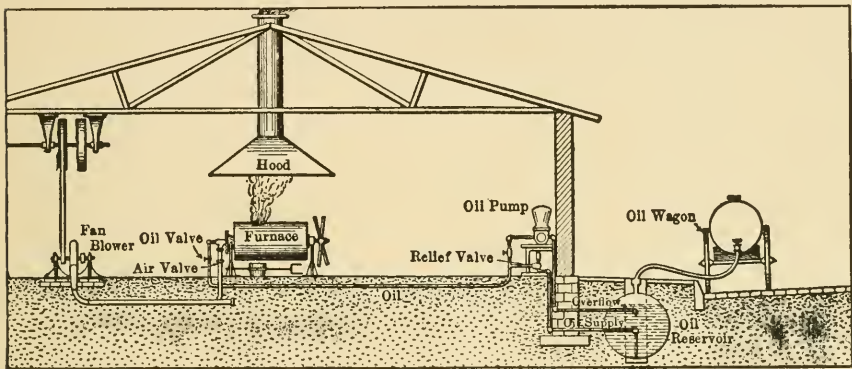

FIG. 112.

The air is supplied from a blower or from a storage tank of compressed air, and is regulated by a valve. Fig. 110 is a general view of the furnace and its arrangement.

The Charlier rolling furnace is shown in Fig. 111. This furnace consists of a metallic casing lined with fire-brick and having an opening in the centre of rotation at one end, through which the fuel and air are admitted to the melting chamber. The arrangement of this furnace is similar to the one previously shown. Fig. 112 shows a general plan of a plant equipped with a Charlier furnace.

CHAPTER XII

CAST-IRON ALLOYS

To toughen cast iron: 10 to 15 per cent of wrought iron scrap (stirred in); $\frac{1}{4}$ to 1 per cent of copper (stirred in).

To toughen cast iron or to form semi-steel: Add from 5 to 30 per cent of steel scrap to the charge of iron in the cupola.

To harden cast iron: Mix $\frac{1}{2}$ pint vitriol, 1 peck common salt, $\frac{1}{2}$ lb. saltpetre, 2 lbs. alum, $\frac{1}{4}$ lb. prussic potash, $\frac{1}{4}$ lb. cyanide potash. Dissolve the mixture in 10 gallons of soft water. Heat the iron to a cherry-red and dip into the solution. For a harder and deeper skin on the iron, repeat the heating and dipping two or more times.

To soften or to anneal cast iron: Heat to a cherry-red, then pack in a coating of bone-black and cover with ashes to allow cooling very slowly.

TABLES

MELTING-POINTS OF DIFFERENT BRANDS OF IRON

Combined Carbon. Percentage.	Graphite. Percentage.	Character of Fracture.	Melting-point. Deg. F.	Remarks.
1.60	3.16	Gray	2210	Samples cast from same ladle
4.67	.03	White	2000	
1.57	2.90	Gray	2250	Samples cast from same ladle
4.20	.20	White	1990	
1.20	2.90	Gray	2250	Samples cast from same ladle
3.90	.16	White	2000	

MELTING-POINTS OF SOLIDS

Cast iron	2250 deg.	Lead	600 deg.
Wrought iron	3981 deg.	Zinc	741 deg.
Gold	2587 deg.	Cadmium	602 deg.
Silver	1250 deg.	Saltpetre	600 deg.
Steel	2501 deg.	Tin	420 deg.
Brass	1897 deg.	Sulphur	225 deg.
Copper	2550 deg.	Potassium	135 deg.
Glass	2377 deg.	Antimony	951 deg.
Platinum	3077 deg.	Bismuth	476 deg.

METAL ALLOYS (VALUES REPRESENT PROPORTIONAL PARTS)

	Copper.	Tin.	Zinc.	Lead.	Anti- mony.	Bis- muth.
Brass valves	9	1	.50			
Brass bearings	10	1.50	.50			
Bell metal	15	5				
Yellow brass	36	2.50	17	2.50		
Gun metal	9	1				
Fine solder		1		1		
Plumber's solder		1		2		
Cast-iron solder		2		1		
Babbitt metal	1	10			1	
Metal to expand in cooling				9	2	1
Type metal				9	1	
Hard bronze for lathe bearings	80	20				

CHILLED-ROLL IRON

No. of Test.	Approx. Diameter of Bar. Inches.	Exact Diameter of Bar. Inches.	Breaking Load. Pounds.	Area of Bar. Sq. Inches.	Strength per Square Inch. Pounds.	Deflection. Inches.
1	$1\frac{1}{8}$	1.140	3.250	1.021	3.183	.105
2	$1\frac{5}{8}$	1.655	9.500	2.151	4.417	.090
3	$1\frac{5}{16}$	1.968	15.250	3.042	5.013	.085

GUN-CARRIAGE IRON

4	$1\frac{1}{8}$	1.122	2.780	.988	2.812	.100
5	$1\frac{5}{8}$	1.664	9.250	2.174	4.264	.110
6	$1\frac{5}{16}$	1.859	11.820	2.714	4.355	.100

CAR-WHEEL IRON

7	$1\frac{1}{8}$	1.174	2.200	1.082	2.033	.053
8	$1\frac{5}{8}$	1.690	8.100	2.244	3.610	.070
9	$1\frac{5}{16}$	2.008	13.500	3.167	4.263	.072

HEAVY MACHINERY IRON

10	$1\frac{1}{8}$	1.187	2.800	1.106	2.530	.092
11	$1\frac{5}{8}$	1.705	7.100	2.282	3.111	.072
12	$1\frac{5}{16}$	2.001	11.900	3.143	3.786	.079

STOVE-PLATE IRON

13	$1\frac{1}{8}$	1.182	2.500	1.097	2.288	.117
14	$1\frac{5}{8}$	1.745	6.050	2.391	2.530	.078
15	$1\frac{5}{16}$	2.047	9.900	3.288	3.011	.081

BESSEMER IRON

16	$1\frac{1}{8}$	1.175	2.150	1.084	1.983	.100
17	$1\frac{5}{8}$	1.698	5.500	2.263	2.430	.100
18	$1\frac{5}{16}$	1.991	8.900	3.112	2.860	.085
19	1 in. square	.994	1.757	.988	1.778	.150

CHEMICAL ANALYSIS OF IRONS DESCRIBED ABOVE

Class of Iron.	Silicon.	Sulphur.	Man-ganese.	Phos-phorus.	Com-bined Carbon	Graph-itic Carbon	Total Carbon
Chill iron84	.071	.285	.547	.61	2.45	3.06
Gun-metal73	.059	.408	.453	.76	2.47	3.23
Car-wheel78	.132	.306	.364	1.07	2.36	3.43
General machinery.	1.30	.053	.224	.433	.58	3.31	3.89
Stove-plate	2.47	.094	.265	.508	.19	4.00	4.19
Bessemer iron	1.52	.059	.326	.083	.49	3.73	4.22

SIZE AND CAPACITY OF FOUNDRY LADLES

	Capacity in Pounds.	Inside Dimensions.			Allows for Daubing.		Allows at Top over Capacity. Inches.
		Diameter.		Depth. Inches.	At Bottom. Inches.	At Sides. Inches.	
		Top. Inches.	Bottom. Inches.				
Hand and bull ladles	50	8.25	6.25	6	.50	.375	.50
	100	10	9	9.50	1	.50	1.50
	150	11	10	10.50	1	.50	1.50
	200	12	11	11.50	1	.50	1.50
	250	13	12	12.50	1	.50	1.50
Crane ladles	300	14	12.50	13	1	.50	1.50
	350	14.50	13	13.50	1	.50	1.50
	400	15.50	14	14.50	1.25	.75	1.75
	500	16.50	15	15.50	1.25	.75	1.75
	600	17.50	16	17	1.25	.75	1.75
	700	18	16.50	17.50	1.25	.75	1.75
	800	18.50	17	18	1.25	.75	1.75
	1,000	20.50	18.50	19.50	1.50	1	2
	1,200	21.50	19.50	21	1.50	1	2
	1,500	23	21	22	1.50	1	2
	2,000	25.50	23.50	24.50	1.50	1	2.50
	2,500	27	25	26	1.50	1	2.50
	3,000	28.50	26	27.50	1.50	1	2.50
	3,500	30	27.50	29	1.50	1	2.50
	Crane ladles with pouring gear	4,000	31.50	28.50	30	1.50	1
4,500		33.50	30.50	32	2	1.50	3
5,000		34.50	31	33	2	1.50	3
6,000		36.50	33	35	2	1.50	3
8,000		40.50	36.50	38.50	2.50	1.75	3
10,000		43.50	39	41	2.50	1.75	3.50
12,000		45.50	41	43.50	2.50	1.75	3.50
14,000		48	43	45.50	2.50	1.75	3.50
16,000		50	45	47.50	2.50	1.75	3.50
18,000		52	46.50	49	2.50	1.75	3.50
20,000		53.50	48	50.50	2.50	1.75	3.50
24,000		57	51	54	2.50	2	3.50

SHRINKAGE OF CASTINGS (APPROXIMATE VALUES ONLY)

Metal.	Inches per Lineal Foot.
Cast iron.....	.125
Brass.....	.1875
Tin.....	.19
Zinc.....	.3125
Steel.....	.25

WEIGHTS OF CASTINGS FROM PATTERNS WHERE NO CORES ARE USED

A Pattern Weighing 1 Pound made of	Will Weigh when Cast in				
	Cast Iron, Pounds.	Zinc, Pounds.	Copper, Pounds.	Yellow Brass, Pounds.	Gun Metal, Pounds.
Mahogany, Nassau . . .	10.7	10.4	12.8	12.2	12.5
“ Honduras . . .	12.9	12.7	15.3	14.6	15.0
“ Spanish . . .	8.5	8.2	10.1	9.7	9.9
Pine, red	12.5	12.1	14.9	14.2	14.6
“ white	16.7	16.1	19.8	19.0	19.5
“ yellow	14.1	13.6	16.7	16.0	16.5
Oak	9.0	8.6	10.4	10.1	10.9

WEIGHTS OF ONE CUBIC FOOT OF METALS WITH THEIR TENSILE STRENGTH

Metal.	Weight of 1 Cubic Foot in Pounds.	Tensile Strength per Square Inch in Pounds.
Cast iron	450	16,500
Ordinary brass	525	36,000
Wrought iron	480	50,000
Hard structural steel	490	78,000
Aluminum	166.5	26,800

WEIGHT IN POUNDS OF ONE CUBIC INCH OF DIFFERENT METALS

Brass (average)3023	Zinc, cast26
Bronze306	Antimony242
Copper, cast3135	Bismuth355
Gold, pure6965	Manganese289
Iron, cast2622	Silver378
Iron, wrought282	Platinum735
Lead, cast415	Cadmium312
Steel281	Potassium031
Tin, cast263		

MIXTURES FOR PHOSPHOR-BRONZE BEARING METAL

Number of Mixture.	Copper. Per Cent.	Lead. Per Cent.	Tin. Per Cent.	Phosphorus. Per Cent.
1	79.0	10.0	10	1.0
2	79.7	9.5	10	.8
3	79.7	10.0	10	.3

SIZE AND CAPACITY OF CRUCIBLES

Number of Crucible.	Outside Height. Inches.	Greatest Outside Diameter. Inches.	Capacity in Molten Metal. Pounds.
1.....	3.50	3	3
2.....	4	3.25	6
3.....	4.625	3.75	9
4.....	5.125	4.25	12
5.....	6	4.625	15
6.....	6.50	5.125	18
8.....	7.25	5.875	24
10.....	8.25	6.25	30
12.....	8.625	6.50	36
14.....	9.125	7.25	42
16.....	9.625	7.75	48
18.....	10	8.125	54
20.....	10.625	8.625	60
25.....	11.125	9	75
30.....	11.75	9.375	90
35.....	12.25	9.75	105
40.....	12.625	9.875	120
45.....	13	10.50	135
50.....	13.75	10.75	150
60.....	14.125	11.25	180
70.....	14.75	11.75	210
80.....	15.50	12.50	240
100.....	16.125	13	300

GLOSSARY

Air-dried.—The surface drying of cores left in open air too long before placing in oven. Molds left open also dry out on surface, causing crumbling or washing when metal is poured.

Air hoist.—A piston and cylinder suspended from an overhead track or traveling crane and operated by compressed air. For hoisting ladles, flasks, or weights in the foundry.

Alloy.—Any compound of two or more metals, as copper and zinc to form brass.

Anchor.—A contrivance used to hold parts of the mold down or together. See PULLEY ANCHOR.

Arm.—The portion of a pulley which connects the hub and the rim.

Ash pit.—The space underneath a fire box, in a core oven or brass furnace, to receive the ashes which fall from the grate.

Bars.—The framework inside the cope of a molding flask, to retain the molding sand in position while lifting or handling the flask, and also to resist the pressure of metal when casting.

Batten.—A piece attached to a thin, flat pattern for the purpose of strengthening and keeping it straight; not a part of the pattern nor to be a part of the casting. It should be marked "stop-off," and the recess formed by this piece in the mold should be filled up or stopped off after the pattern has been removed from the sand.

Bed charge.—The first or lower charge of coke in a cupola, reaching from the bed or bottom to a point above the tuyères.

Bedding in.—The process of molding a pattern by embedding it in the sand in the exact position in which it is to be cast.

Bellows.—An instrument for forcing air through a tube. Used in foundries for the purpose of blowing away loose sand from the molds.

Binders.—The various articles used in loam, core sand, and facings for the purpose of holding the sand together when dry, such as glue water, molasses, linseed oil, flour, etc.

Blacking.—A thin facing of carbon, consisting of pulverized charcoal or plumbago, by which the fusible ingredients of the sand are protected from the intense heat of the metal when casting. Blacking is sometimes applied as a powder to green sand molds; but for dry sand, loam, or skin-dried molds and cores wet blacking or black wash is used. Wet blacking consists of common blacking mixed with water thickened with clay to the consistency of thin paint. Wet blacking somewhat hardens the surface of a mold when dry.

Black lead.—See GRAPHITE.

Blast.—The current of atmospheric air delivered from the blower or fan under pressure through the blast pipe and tuyères into the cupola.

Blast gauge.—The blast gauge is a device to determine the amount of pressure in the wind belt or jacket of a cupola while in operation. This instrument is a form of manometer.

Blast pipe.—The pipe through which the air passes from the fan or blower to the cupola.

Blower.—A box with revolving wings or vanes inside, so constructed and arranged as to force a pressure of air through the blast pipe into the cupola.

Blow-holes.—Holes occurring in castings, due to air and gas in the metal and in the mold when casting. Blow-holes are the result of insufficient venting and of moisture.

Bott stick.—A stick of wood or bar of iron with one flat end on which to place a ball of clay in stopping the flow of iron from the cupola.

Bottom board.—The board on which the flask rests when in position to cast. It may be of iron or wood.

Breast.—The clay front built in the opening over the spout of the cupola and through which the tapping port is made.

Bricking up.—Building up the skeleton of a loam mold by means of bricks cemented together with loam.

Bull ladle.—A vessel for handling molten metal. It is placed in a shank and is carried by two or more men.

Burning on, or casting on.—The process of mending cracked or broken castings or of adding on metal, where the casting is unsound or incomplete, by means of flowing molten metal over the part to be treated until fusion takes place.

Burnt sand.—Sand which has had contact with molten metal. The sand which forms the face of a mold invariably becomes burnt.

Butting, or butt ramming.—The process of butting or ramming the sand with the flat end of the rammer.

Camber.—The curving of certain types of casting in cooling, due to want of symmetry in their sectional forms, by reason of which one portion cools off more rapidly than the other, causing distortion of figure in the longitudinal direction.

Carrier.—A casting which is attached to the arm of a gear molding machine and to which the tooth block is attached.

Casting.—A piece of metal work obtained by pouring molten metal into a mold.

Casting on.—The same as burning on.

Changing hook.—An S crane hook which is double at one end and which is useful in transferring from one crane to another.

Chaplet.—Chaplets are iron supports to retain a core in its proper position where core prints can not be used.

Chaplet block.—A block of wood rammed in the sand to receive the spike of a chaplet nail. The block affords the requisite steadiness to the chaplet when in position.

Chaplet nails.—A chaplet with one end flat and the other a sharp point to be driven into the bottom board or into a block of wood rammed up in the sand which forms the mold.

Charcoal.—Coal made by charring wood. It is used in drying molds. Oak charcoal pulverized is used for the purpose of blackening molds.

Cheek.—An intermediate part of a mold where more than two parts are necessary.

Chill.—A metal form placed in a mold or forming a portion of the mold against which the iron is poured to produce a chilled casting.

Chilled casting.—A casting whose surface is hardened by pouring molten iron against a chill.

Cinder bed.—A bed or layer of cinders or coke placed below a pit mold for the purpose of carrying off the gases that pass downward. The cinder bed is connected to the surface by a vent pipe.

Clamps—are wrought or cast-iron bars whose ends form a right angle. They are useful in binding together the top and bottom of a flask while pouring the metal.

Clamping.—Placing the clamps in their proper position on the flask when the mold is completed.

Clay wash.—A mixture of clay and water.

Coke bed.—See CINDER BED.

Cold shots.—Small globular particles of metal which are formed by the first splashing of metal in a mold and which harden quickly and do not amalgamate with the other metal in the mold.

Cold-shuts—are produced by pouring the metal too cold or too slowly into the mold and are due to imperfect amalgamation of the metal in the mold. They may also be caused by gases in the mold, arising from the use of facing sand containing too great a percentage of sea coal.

Contraction.—See SHRINKAGE.

Cope.—The top part of a flask or mold.

Core.—A body of sand in the mold for forming interior openings or holes in the casting.

Core barrel.—A hollow bar or pipe on which a cylindrical core is formed. The barrel gives the core strength, and also openings through the sides, affording vent for the gases generated in casting the metal around the core.

Core board.—A board whose edge is profiled to a sectional form of a desired core.

Core box.—A box in which a core is to be formed or molded. Its interior shape to be the same as the outside form of core desired.

Core carriage.—A carriage upon which the cores are placed after being molded and on which they are conveyed into the drying oven.

Core irons.—Rods or bars of iron rammed up in a core to give it strength.

Core lathe.—A frame having V's or bearings in which to place a core barrel provided with a crank, on which barrel a core is to be formed and trued up by revolving the core against a sweep which forms the desired shape of the core.

Core mixture.—A core sand dampened and mixed with a binder in such proportions that when dry it will become hard.

Core oven.—An oven in which to bake or dry cores after molding them.

Core plate.—A plate on which cores are formed or placed while drying.

Core print.—An attachment or projection on a pattern which forms a seat or pocket in the sand in which the core is to be placed in the mold after the pattern has been removed.

Core rope.—Ropes or strings used for forming vents in crooked cores, from which rods or wires could not be withdrawn without damage to the core.

Core sand.—Any sharp sea sand or nearly pure silica.

Core trestles.—Upright standards or trestles whose tops are provided with V-shaped recesses or bearings in which to place the ends of a core bar or barrel while revolving to sweep up a core.

Core wash.—See BLACKING.

Crane.—A device for lifting and moving heavy weights in a foundry, such as flasks, weights, and ladles of molten metal.

Crane ladle.—See LADLE.

Crushing.—Compressing the sand in the mold by too great a strain on the clamps after the pattern has been withdrawn, causing the mold to crumble and sand to fall into the mold.

Crystalline fracture.—Where the face of the break shows a coarse formation of crystals.

Cupola.—A cylindrical furnace for melting iron. A cupola is lined with fire-brick and provided with ports or tuyères near its base through which a pressure of air is forced.

Cutting over.—The process of shoveling over the sand to obtain an even mixture and temper.

Daubing.—Lining or plastering up the interior of a cupola or ladle with clay or molding sand. The operation is performed with the hands.

Dowel.—A pin of wood or metal used to hold the parts of a divided pattern in their respective positions while they are being rammed in the sand.

Draft.—The allowance or slight taper made on a pattern to aid in its removal from the sand after being rammed up. The portion of the pattern at the parting line of the mold must be larger than that extending into the cope or drag.

Drag.—The lower part of a mold when in position to be cast.

Draw.—The casting draws when the shrinkage causes depressions of the surface or openings in the interior. See DRAWING.

Drawback.—A section of a mold rammed up separate from the drag and cope and parted by a plate or piece of cloth, and which may be drawn back for the convenience of the molder in removing the pattern or in patching the mold.

Drawback plate.—The iron plate on which a drawback is rammed up.

Drawing.—Removing the pattern from the sand after the mold has been formed, also increasing the depth of a mold without altering the dimensions of the pattern by drawing the pattern a part of the length upward and ramming the sand around its upper portion.

Draw plate.—A plate attached to a pattern for the purpose of receiving the rapping iron and lifting screw.

Draw spike.—A tool pointed at one end to be driven into the pattern for the purpose of lifting it from the sand.

Drop-out.—The whole or part of the sand falling out of the cope of a mold while turning over or closing a flask.

Drying.—The process of evaporating moisture from a mold by means of hot air injected, or of a charcoal fire basket, or by baking in an oven.

Dry sand.—Mixtures of sand which, after being dried in

an oven or otherwise, become hard and better resist the strain from molten metal.

Dull iron.—Iron which has not been heated to a proper temperature, or which has been allowed to remain in the ladle too long before pouring. Dull iron causes seams, cold-shuts, and unsound castings.

Facing.—Any material used to mix with the sand for the purpose of preventing the fusion of the sand and the metal. Pulverized sea coal is commonly used.

Facing sand.—The mixture of sand which forms the face of the mold.

Fan.—An apparatus provided with revolving wings enclosed within a case for the purpose of forcing air into the blast pipe of a cupola.

Feeder head.—A body of molten metal contained in a riser or opening above a mold for the purpose of supplying metal to the mold when shrinkage takes place.

Feeding.—Forcing the metal into the mold from the feeding head during the time it is liquid by means of an iron rod kept in motion vertically in the feeding head. It is sometimes termed “pumping” a mold.

Feeding rod.—A wrought-iron bar used for the purpose of feeding a mold.

Fin.—A thin projection on the casting at the parting line of the mold, caused by an imperfect joint.

Fire-clay.—A kind of clay which will sustain intense heat and which is used in furnaces, cupolas, and ladle linings.

Flask.—A box or frame in which a mold is formed. A flask must consist of two or more parts and may be made of either wood or metal.

Flow-off gate.—A vertical passage through which the metal flows after the mold has been filled. Its top is lower than the level of the pouring gate.

Flux.—Any material used in a melting furnace or cupola

to cause the slag to become more liquid and more easily drawn off before tapping out the iron. Limestone is commonly used.

Follow-board.—A board which conforms to the form of the pattern and defines the parting surface of the drag.

Foundation plate.—A plate of cast iron placed in the bottom of a mold to receive the spindle to maintain a sweep.

Founding.—The casting of metal in molds.

Fusing.—The iron and sand are said to fuse when a hard coating of sand adheres to the metal after casting, due to the heat of the molten metal.

Gaggers—are made of iron in the shape of the letter L and are used for the purpose of anchoring the sand to be lifted in the cope of a mold.

Gangway.—The passages between the molding floors and leading from the cupola. The gangway is usually laid with iron plates over which trucks or ladle carriages are run.

Gate.—The terminus of the runner where the metal enters the mold. The opening through the cope left by the gate stick is commonly called the gate.

Gate cutter.—A piece of thin sheet metal bent to the shape of the letter U. It is used to cut the runners which conduct the metal to the mold.

Gate stick.—A wooden pin or stick used by the molder to form the opening leading from the pouring basin to the runner. It is placed in position before the sand is rammed in the cope.

Grab hook.—Hooks connected by short chains or rods for the purpose of attaching loads to the crane hook.

Graphite.—Carbon in one of its conditions, distinguished by its usually crystallizing in foliated, six-sided prisms, though often massive, by its softness, by its metallic lustre, and by leaving a dark lead-colored trace on paper. It is often called plumbago or black lead.

Green sand.—Common molding sand suitably tempered to form molds for metal without subsequent drying.

Gutters.—Shallow channels cut at the parting of a mold for the purpose of receiving the vents which are led off at the parting and of conducting them to a relief vent.

Hand ladle.—See LADLE.

Hard ramming.—Ramming the sand in a mold until hard. Some molds should be rammed hard to resist the pressure of the metal.

Hatching up.—Cutting or roughening the surface of a mold for the purpose of better holding new sand which may be added in patching.

Hay rope.—Hay twisted or spun to the form of a rope, used to wind around a core barrel or hollow bar in striking up round cores or loam. The hay holds the sand or loam to the bar and also affords escape for the gases.

Hot metal.—Metal which is in its liquid state. Light and thin castings should be poured with hot metal.

Ladle.—An iron vessel lined with fire-clay and used in handling molten metal from the cupola to the mold. Hand ladles are carried by one man and bull ladles by two or more. Crane ladles are handled by the crane.

Leveling.—Making a bed of sand level by the use of parallel strips, a straight edge, and a level.

Leveling strips.—Parallel strips used in leveling sand beds.

Lifter.—A tool used for removing loose sand from the bottom of deep molds.

Lifting screw.—An iron rod with a screw or thread cut at one end and an eye or loop at the other. The screw may be used in the wood pattern and the thread in a tapped plate attached to the pattern.

Lift off.—To remove a portion of a mold after ramming up.

Loam.—Loam sand is a mixture of sand, clay, and venting material, such as horse manure, which gives a firm, hard, but open-grained body when dry. The mixture must be regulated by the class of castings for which the loam is to be used.

Loam board.—A board the edge of which is profiled to a sectional form of a mold which it is to strike up. It is swept around a vertical bar to which it is bolted.

Loam mold.—A mold constructed of loam.

Loam plate.—A plate of iron cast in an open mold and studded with spikes upon which the brickwork of a loam mold is built.

Loose piece.—A portion or projection made detachable from the body of a pattern for convenience in molding.

Melting zone.—A space above the tuyères in a cupola where the greatest heat is obtained.

Mold.—The matrix or reverse form of a pattern made in sand.

Molding.—The process of forming a mold in which metal is to be cast.

Molding machine.—Any machine by which the operation of molding is performed or the drawing of a pattern is made safe and expeditious.

Molding sand.—Sand used for the purpose of forming a mold, and possessing the quality of resisting the pressure of molten metal as well as the heat. It must also be porous or open when compressed in order to allow the free escape of the gases generated by the heat of the metal.

Nowel.—The bottom portion of a mold when in position to cast. Commonly called drag.

Old sand.—Sand which has been used for the purpose of molding until it becomes old, black, and burnt from contact with the molten metal.

Open sand molding.—Molds formed in the floor of the foundry and having no cope or covering. Only castings

having one flat side or surface can be formed this way. The mold must in all cases be perfectly leveled.

Parting sand.—Sand used for the purpose of preventing two parts of a mold from uniting. It causes the sand to part when the flask is opened after ramming. Sharp sand or burned core sand is commonly used.

Patching.—The process of repairing a mold after the pattern has been removed from the sand.

Pattern.—A model from which to form a mold; its impression in the sand forming a mold in which to pour molten metal to form a casting.

Peeling.—A casting is said to peel when the molding sand and iron do not fuse. After the casting has cooled the surface of the metal is left smooth and free from sand.

Pit molding.—Forming a mold in a pit dug in a foundry floor. Light pit molding is usually of green sand.

Plate anchor.—The anchor used in a pulley anchor having plates to cover the surfaces between the arms.

Plate molding.—Dividing the pattern at its centre and placing each half on one side of a parting board which is provided with pin-holes corresponding with the pins of interchangeable flasks. The drag and cope may be rammed on opposite sides of the board, and after the board has been removed the flask may be closed.

Plumbago.—A mineral consisting chiefly of carbon. It is used for blacking and for facing. It is properly called graphite, but often called black lead.

Pouring.—The emptying of the molten metal from the ladle into the pouring basin or gate of a mold.

Pouring basin.—A reservoir or basin formed on the cope of a mold to receive the molten metal and from which it flows into the gate.

Pulley anchor.—The part of the mold of a pulley between the arms and the face of the cope.

Pulley foot.—A cone or pyramid placed in the anchor of a pulley mold for the purpose of ensuring removing and replacing to the same position. The pulley foot may be separate and placed in the anchor while ramming, or it may be a part of the anchor, as in a plate anchor.

Rammer.—A tool used for the purpose of ramming the sand in the flask and around the pattern. The rammer is usually made of iron. One end is called the pein and the other the butt. The pein end is rectangular in section and the butt end is round and flat.

Rapping.—The process of loosening the pattern from the sand while yet in the mold. A bar is inserted in the pattern and is rapped sidewise in every direction until the sand compresses and is free from the pattern, after which the pattern may be easily withdrawn.

Rapping bar.—A bar of iron either pointed or threaded at one end to be inserted into a pattern for the purpose of rapping.

Rapping hole.—A hole bored in a pattern or in a rapping plate let into the pattern to receive the rapping bar.

Rapping plate.—An iron plate screwed to or let into a pattern having a hole to receive the rapping bar.

Reverse mold.—A dummy mold on which a portion of an actual mold is to be rammed.

Riddle.—A sieve for sifting sand for the purpose of molding.

Riser.—An opening from the mold to the top of the flask through which gases may escape and the surplus metal rise above the upper surface of the casting.

Runner.—A channel cut in the sand to conduct the metal from the pouring basin to the gate.

Sand sifter.—A mechanical device for the purpose of sifting sand.

Scabbed castings.—Scabbed castings are those on the surface of which rough and uneven projections appear. Scabs occur from various causes, such as imperfect venting, improper ramming, unsuitable material, too rich facing sand, excess of moisture, etc.

Scrap.—That which is of no use in its present form. The old castings which are only good for the metal in them, or castings which cannot be used, are called scrap.

Sea coal.—Sea coal is ordinary bituminous coal. When pulverized and mixed with molding sand, it is called sea-coal facing.

Shrinkage.—Contraction of metal while cooling after casting.

Shrink-holes.—Openings in the surface or in the interior of a casting caused by the shrinkage of the metal in cooling.

Sinking head.—The prolongation upon a casting vertically to supply metal to replace shrinkage. The excess length is cut off, leaving the desired casting.

Skeleton core box.—A frame or skeleton in which to form a core without a full core box. Skeleton core boxes are commonly used in forming one-half of a round core by means of a strike stick.

Skim gate.—An arrangement of gates, runners, and risers which will effect the separation of the impurities before the metal enters the mold.

Skimmer.—A bar of iron usually bent to the shape of the letter L at one end for the purpose of preventing the slag and dirt from following the metal as it flows from the ladle to the pouring basin of a mold.

Skimming.—The holding back of the slag and dirt on the surface of molten metal while being poured from the ladle into the mold.

Skin-drying.—The process of drying the face of a mold.

Slag.—The refuse from the cupola, caused by impurities

of the metal and fuel, as well as by the fused compounds of the silica and alumina in the lining and daubing.

Slag hole.—A port hole in a cupola slightly below the level of the tuyères for the purpose of tapping out the slag before tapping the iron.

Sleeking.—See SLICKING.

Slick.—A tool used for smoothing the surface of a mold. An ordinary trowel may be used for a slick.

Slicking.—Smoothing and finishing the surface of a mold with a trowel or slicking tool. Sometimes spelled sleeking.

Sling.—A device made of iron or of rope for the purpose of handling flasks or weights. The sling is used to connect the crane to a weight or to the trunnion of a flask.

Snap-flask.—A small flask used in bench molding having a hinge at one corner and a latch at the diagonal corner.

Soldiers.—Strips of wood used by the molder to strengthen or to anchor bodies of sand.

Socket.—The base for supporting the spindle in a sweep mold. See FOUNDATION PLATE.

Spongy.—A casting is spongy when honeycombed by blow-holes. The centre of a casting may be spongy from shrinkage of the metal in solidifying.

Spout.—A box or gutter lined with clay to conduct the molten metal from the tapping hole to the ladle.

Spray can.—A can fitted with a blow-pipe or bellows so that the liquid in the can may be forced out in a spray or mist.

Sprue.—The casting formed in the gate of a mold.

Staking.—The setting of the cope on a pit mold by means of stakes.

Stopping off.—The process of filling up a portion of the mold which is not desired to be cast.

Stopping-off piece.—A piece used as a guide or template

in stopping off. A stop-off piece is a duplicate of the desired casting at the point stopped off on the pattern.

Stopping over.—Filling up with sand the space over a core placed in a print pocket.

Straining.—The distortion of a mold by the pressure of the metal, usually caused by insufficient ramming of the sand.

Strike stick.—A straight edge or form beveled at its edge for the purpose of cutting the sand or loam in building up a mold or core.

Stripping plate.—The plate which holds the sand in place while the pattern is being drawn.

Strong sand.—Molding sand is called strong when it contains clay and when upon drying it becomes hard and will not crumble.

Swab.—A substitute for a brush for dampening sand in a mold or around a pattern before it has been removed from the sand. Swabs are usually made of hemp.

Swabbing.—The dampening with a swab of the joint edges or interior sections of a mold for the purpose of strengthening the sand and causing it to be more plastic and coherent.

Sweep.—A board having the profile of a desired mold. A sweep must be attached to a spindle and revolved around the spindle to give the mold the proper form.

Tap hole.—The hole through the breast of a cupola through which the metal flows.

Tapping.—Opening the port of a foundry cupola for the purpose of allowing the metal to flow into the ladle.

Tapping bar.—A long bar of iron pointed at one end and having a loop at the other to serve as a hand hold. It is used for the purpose of opening the tap hole in a cupola to allow the metal to flow out.

Tempering sand.—The process of dampening and mixing the sand preparatory to ramming a mold.

Test bar.—A bar of iron cast for the purpose of testing the strength of the metal.

Trammel.—Another name for a beam compass.

Traveling crane.—An apparatus arranged on overhead tracks and so constructed as to move a load in any direction.

Trowel.—A tool similar to a mason's trowel, used in slicking, patching, and finishing a mold. Trowels are of various shapes and sizes.

Tucking.—Compressing the sand with the fingers under flask bars or around gagers or soldiers where the rammer can not be used.

Turning over.—The operation of inverting the drag of a mold with the pattern in the sand. The top and bottom are covered with boards, clamped up, and turned over.

Turn-over board.—The board upon which a pattern is placed while ramming up the drag of a mold.

Tuyères.—The openings which admit the air blast to the interior of a cupola or blast furnace.

Vents.—Any means provided for the escape of gases or of steam generated by contact of molten metal with cores or molding sand.

Vent gutter.—A groove or an opening cut in the sand to conduct the gases away from the vents.

Venting.—The process of making vent holes or openings in the mold by means of a vent wire, or otherwise to allow the gases to escape while casting.

Vent strings.—Strings used for the purpose of venting crooked cores when wires or rods could not be employed without damaging the core. Sometimes wax strings are used and melted out in drying the core.

Vent wire.—A small rod or wire used in forming a vent.

Weak sand.—Sand having a very small percentage of clay, thus having but little strength at the usual temper and hardness.

Wedges.—Small V-shaped pieces for the purpose of blocking under a clamp or over a chaplet. Wedges may be of wood or iron.

Wet blacking.—See BLACK WASH.

Wind jacket.—The chamber surrounding a cupola into which the air is forced from the blast pipes and from which it enters the tuyères leading to the cupola.

INDEX

- Bedding in, 15.
Blow-holes and shrink-holes, 111.
Brass, molding of, 199; founding of, 202; melting furnace for, 202;
same for fuel oil or gas, 206.
Burning on or casting on, 112.
- Castings, feeding of, 95; chilled, 172; malleable, 176; cleaning of,
180; steel, 195.
Cast-iron alloys, 208, 209.
Chaplets, described, 100; setting and wedging of, 103.
Clamping or weighting of cope and cores, 107.
Columns, molding of, 44.
Compressed air, 185.
Coping out, 11.
Cores, setting and venting of, 21, 98; cover, 37; described, 123; ram-
ming of, 125; wires and rods for, 125; baking or drying of, 128;
pasting of, 127; nearly submerged, 146.
Core anchors, 144.
Core barrel, 136.
Core box, 138; skeleton core box, 139.
Core-making machines, 150.
Core mixtures, 134; core blacking mixtures, 135.
Core ovens, 129.
Core plates, 143.
Cupola, preparing of, 155; tapping out and stopping up of, 160.
- Flasks, 74.
Fly-wheels, methods of casting, 64.
Follow-board, 115.
Foundry blowers, 169.
Foundry ladles, 166.
Furnace cupola, 151; reverberatory, 162; brass melting, 202; same for
fuel oil or gas, 206.
- Gaggers, 88.
Gears, molding of, 48.

Hay-rope machines, 136

Loam mixtures, 67

Loam molding, 66.

Molding, bench, 114; plain, 1; with divided pattern, 8; open sand, 18; of columns, 44; of gears, 48; pit, 59; loam, 66; brass, 199.

Molding machines, 115.

Molds, venting of, 19; parting of, 82; gating of, 83; patching of, 92; stopping off of, 94; crushing of, 110; match for a, 115; dry sand, 53; finishing dry sand, 55; blacking dry sand, 55; drying dry sand, 56.

Nailing or rodding, 91.

Pneumatic chipping hammer, 188.

Pneumatic crane, 185.

Pneumatic hoist, 185.

Pneumatic molding machine, 185.

Pneumatic sand rammer, 188.

Pneumatic sand sifter, 185.

Pneumatic shaker, 189.

Pouring basins, 88.

Pulley anchors, 40.

Pulley rings, 38.

Risers, 85.

Sand, molding, 69; tempering of, 69; cutting over of, 69; riddling of, 71; facing, 72; ramming of, 77; parting, 83.

Sand-blast machine, 189.

Sand crusher, 194.

Sand mixers, 194; centrifugal, 194.

Sand sifter, rotary, 194.

Shrinkage, 111.

Skin gates, 86.

Soldiers, 90.

Steel, casting of, 195.

Sweeps and spindles, 60.

Three-part work, 30.

Tools, molders', 76.

Tumbling barrels, 181.

Vent gutters, 147.

SHORT-TITLE CATALOGUE

OF THE

PUBLICATIONS

OF

JOHN WILEY & SONS,

NEW YORK.

LONDON: CHAPMAN & HALL, LIMITED.

ARRANGED UNDER SUBJECTS.

Descriptive circulars sent on application. Books marked with an asterisk (*) are sold at *net* prices only. All books are bound in cloth unless otherwise stated.

AGRICULTURE—HORTICULTURE—FORESTRY.

Armsby's Principles of Animal Nutrition	8vo,	\$4 00
Budd and Hansen's American Horticultural Manual:		
Part I. Propagation, Culture, and Improvement.	12mo,	1 50
Part II. Systematic Pomology.	12mo,	1 50
Elliott's Engineering for Land Drainage.	12mo,	1 50
Practical Farm Drainage 2d Edition, Rewritten.	12mo,	1 50
Graves's Forest Mensuration.	8vo,	4 00
Green's Principles of American Forestry.	12mo,	1 50
Grotenfelt's Principles of Modern Dairy Practice. (Woll).	12mo,	2 00
* Herrick's Denatured or Industrial Alcohol.	8vo,	4 00
Kemp and Waugh's Landscape Gardening. New Edition, Rewritten. (In Preparation.)		
* McKay and Larsen's Principles and Practice of Butter-making	8vo,	1 50
Maynard's Landscape Gardening as Applied to Home Decoration.	12mo,	1 50
Quaintance and Scott's Insects and Diseases of Fruits. (In Preparation).		
Sanderson's Insects Injurious to Staple Crops.	12mo,	1 50
* Schwarz's Longleaf Pine in Virgin Forests.	12mo,	1 25
Stockbridge's Rocks and Soils.	8vo,	2 50
Winton's Microscopy of Vegetable Foods.	8vo,	7 50
Woll's Handbook for Farmers and Dairymen.	16mo,	1 50

ARCHITECTURE.

Baldwin's Steam Heating for Buildings.	12mo,	2 50
Berg's Buildings and Structures of American Railroads.	4to,	5 00
Birkmire's Architectural Iron and Steel.	8vo,	3 50
Compound Riveted Girders as Applied in Buildings.	8vo,	2 00
Planning and Construction of American Theatres.	8vo,	3 00
Planning and Construction of High Office Buildings.	8vo,	3 50
Skeleton Construction in Buildings.	8vo,	3 00
Briggs's Modern American School Buildings.	8vo,	4 00
Byrne's Inspection of Material and Workmanship Employed in Construction.		
	16mo,	3 00
Carpenter's Heating and Ventilating of Buildings.	8vo,	4 00
* Corthell's Allowable Pressure on Deep Foundations	12mo,	1 25

* Dyer's Handbook of Light Artillery.	12mo,	3 00
Eissler's Modern High Explosives.	8vo,	4 00
* Fieberger's Text-book on Field Fortification.	Large 12mo,	2 00
Hamilton and Bond's The Gunner's Catechism	18mo,	1 00
* Hoff's Elementary Naval Tactics.	8vo,	1 50
Ingalls's Handbook of Problems in Direct Fire.	8vo,	4 00
* Lissak's Ordnance and Gunnery.	8vo,	6 00
* Ludlow's Logarithmic and Trigonometric Tables	8vo,	1 00
* Lyons's Treatise on Electromagnetic Phenomena. Vols. I. and II. 8vo, each,	8vo,	6 00
* Mahan's Permanent Fortifications. (Mercur)	8vo, half mor.	7 50
Manual for Courts-martial.	16mo, mor.	1 50
* Mercur's Attack of Fortified Places.	12mo,	2 00
* Elements of the Art of War.	8vo,	4 00
Metcalf's Cost of Manufactures—And the Administration of Workshops. .8vo.		5 00
Nixon's Adjutants' Manual.	24mo,	1 00
Peabody's Naval Architecture.	8vo,	7 50
* Phelps's Practical Marine Surveying.	8vo,	2 50
Putnam's Nautical Charts.	8vo,	2 00
Sharpe's Art of Subsisting Armies in War.	18mo, mor.	1 50
* Tupes and Poole's Manual of Bayonet Exercises and Musketry Fencing.	24mo, leather,	50
* Weaver's Military Explosives.	8vo,	3 00
Woodhull's Notes on Military Hygiene.	16mo,	1 50

ASSAYING.

Betts's Lead Refining by Electrolysis.	8vo,	4 00
Fletcher's Practical Instructions in Quantitative Assaying with the Blowpipe.	16mo, mor.	1 50
Furman's Manual of Practical Assaying.	8vo,	3 00
Lodge's Notes on Assaying and Metallurgical Laboratory Experiments.	8vo,	3 00
Low's Technical Methods of Ore Analysis.	8vo,	3 00
Miller's Cyanide Process.	12mo,	1 00
Manual of Assaying.	12mo,	1 00
Minet's Production of Aluminum and its Industrial Use. (Waldo)	12mo,	2 50
O'Driscoll's Notes on the Treatment of Gold Ores.	8vo,	2 00
Ricketts and Miller's Notes on Assaying.	8vo,	3 00
Robine and Lenglen's Cyanide Industry. (Le Clerc)	8vo,	4 00
Ulke's Modern Electrolytic Copper Refining.	8vo,	3 00
Wilson's Chlorination Process.	12mo,	1 50
Cyanide Processes.	12mo.	1 50

ASTRONOMY.

Comstock's Field Astronomy for Engineers.	8vo,	2 50
Craig's Azimuth	4to,	3 50
Crandall's Text-book on Geodesy and Least Squares.	8vo,	3 00
Doolittle's Treatise on Practical Astronomy.	8vo,	4 00
Gore's Elements of Geodesy.	8vo,	2 50
Hayford's Text-book of Geodetic Astronomy.	8vo,	3 00
Merriman's Elements of Precise Surveying and Geodesy.	8vo,	2 50
* Michie and Harlow's Practical Astronomy.	8vo,	3 00
Rust's Ex-meridian Altitude, Azimuth and Star-Finding Tables.	8vo,	5 00
* White's Elements of Theoretical and Descriptive Astronomy	12mo,	2 00

CHEMISTRY.

* Abderhalden's Physiological Chemistry in Thirty Lectures. (Hall and Defren)	8vo, 5 00
* Abegg's Theory of Electrolytic Dissociation. (von Ende).....	12mo, 1 25
Alexeyeff's General Principles of Organic Syntheses. (Matthews).....	8vo, 3 00
Allen's Tables for Iron Analysis.	8vo, 3 00
Arnold's Compendium of Chemistry. (Mandel).....	Large 12mo, 3 50
Association of State and National Food and Dairy Departments, Hartford, Meeting, 1906	8vo, 3 00
Jamestown Meeting, 1907	8vo, 3 00
Austen's Notes for Chemical Students	12mo, 1 50
Baskerville's Chemical Elements. (In Preparation.)	
Bernadou's Smokeless Powder.—Nitro-cellulose, and Theory of the Cellulose Molecule	12mo, 2 50
Bilts's Chemical Preparations. (Hall and Blanchard). (In Press.)	
* Blanchard's Synthetic Inorganic Chemistry.....	12mo, 1 00
* Browning's Introduction to the Rarer Elements.....	8vo, 1 50
Brush and Penfield's Manual of Determinative Mineralogy.....	8vo, 4 00
* Claassen's Beet-sugar Manufacture. (Hall and Rolfe).....	8vo, 3 00
Classen's Quantitative Chemical Analysis by Electrolysis. (Boltwood).....	8vo, 3 00
Cohn's Indicators and Test-papers.	12mo, 2 00
Tests and Reagents.	8vo, 3 00
* Danneel's Electrochemistry. (Merriam).....	12mo, 1 25
Dannerth's Methods of Textile Chemistry.....	12mo, 2 00
Duhem's Thermodynamics and Chemistry. (Burgess).....	8vo, 4 00
Eakle's Mineral Tables for the Determination of Minerals by their Physical Properties	8vo, 1 25
Eissler's Modern High Explosives.....	8vo, 4 00
Effront's Enzymes and their Applications. (Prescott)	8vo, 3 00
Erdmann's Introduction to Chemical Preparations. (Dunlap).....	12mo, 1 25
* Fischer's Physiology of Alimentation	Large 12mo, 2 00
Fletcher's Practical Instructions in Quantitative Assaying with the Blowpipe.	12mo, mor. 1 50
Fowler's Sewage Works Analyses.....	12mo, 2 00
Fresenius's Manual of Qualitative Chemical Analysis. (Wells).....	8vo, 5 00
Manual of Qualitative Chemical Analysis. Part I. Descriptive. (Wells).....	8vo, 3 00
Quantitative Chemical Analysis. (Cohn) 2 vols.....	8vo, 12 50
When Sold Separately, Vol. I, \$6. Vol. II, \$8.	
Fuertes's Water and Public Health.....	12mo, 1 50
Furman's Manual of Practical Assaying.	8vo, 3 00
* Getman's Exercises in Physical Chemistry.....	12mo, 2 00
Gill's Gas and Fuel Analysis for Engineers.....	12mo, 1 25
* Gooch and Browning's Outlines of Qualitative Chemical Analysis.	Large 12mo, 1 25
Grotenfelt's Principles of Modern Dairy Practice. (Woll).....	12mo, 2 00
Groth's Introduction to Chemical Crystallography (Marshall)	12mo, 1 25
Hammarsten's Text-book of Physiological Chemistry. (Mandel).....	8vo, 4 00
Hanausek's Microscopy of Technical Products. (Winton).....	8vo, 5 00
* Haskins and Macleod's Organic Chemistry	12mo, 2 00
Helm's Principles of Mathematical Chemistry. (Morgan).....	12mo, 1 50
Hering's Ready Reference Tables (Conversion Factors).....	16mo, mor. 2 50
* Herrick's Denatured or Industrial Alcohol	8vo 4 00
Hinds's Inorganic Chemistry.	8vo, 3 00
* Laboratory Manual for Students	12mo, 1 00
* Holleman's Laboratory Manual of Organic Chemistry for Beginners. (Walker).....	12mo, 1 00
Text-book of Inorganic Chemistry. (Cooper).....	8vo, 2 50
Text-book of Organic Chemistry. (Walker and Mott).....	8vo, 2 50

olley and Ladd's Analysis of Mixed Paints, Color Pigments, and Varnishes.

	Large 12mo,	2 50
Hopkins's Oil-chemists' Handbook.....	8vo,	3 00
Iddings's Rock Minerals.....	8vo,	5 00
Jackson's Directions for Laboratory Work in Physiological Chemistry.....	8vo,	1 25
Johannsen's Determination of Rock-forming Minerals in Thin Sections.....	8vo,	4 00
Johnson's Chemical Analysis of Special Steel. Steel-making. (Alloys and Graphite.) (In Press.)		
Keep's Cast Iron.....	8vo,	2 50
Ladd's Manual of Quantitative Chemical Analysis.....	12mo,	1 00
Landauer's Spectrum Analysis. (Tingle).....	8vo,	3 00
* Langworthy and Austen's Occurrence of Aluminium in Vegetable Products, Animal Products, and Natural Waters.....	8vo,	2 00
Lassar-Cohn's Application of Some General Reactions to Investigations in Organic Chemistry. (Tingle).....	12mo,	1 00
Leach's Inspection and Analysis of Food with Special Reference to State Control.....	8vo,	7 50
Löb's Electrochemistry of Organic Compounds. (Lorenz).....	8vo,	3 00
Lodge's Notes on Assaying and Metallurgical Laboratory Experiments.....	8vo,	3 00
Low's Technical Method of Ore Analysis.....	8vo,	3 00
Lunge's Techno-chemical Analysis. (Cohn).....	12mo,	1 00
* McKay and Larsen's Principles and Practice of Butter-making.....	8vo,	1 50
Maire's Modern Pigments and their Vehicles.....	12mo,	2 00
Mandel's Handbook for Bio-chemical Laboratory.....	12mo,	1 50
* Martin's Laboratory Guide to Qualitative Analysis with the Blowpipe.....	12mo,	60
Mason's Examination of Water. (Chemical and Bacteriological).....	12mo,	1 25
Water-supply. (Considered Principally from a Sanitary Standpoint.)	8vo,	4 00
Mathewson's Chemical Theory for First Year College Students. (In Press).		
Matthews's Textile Fibres. 2d Edition, Rewritten.....	8vo,	4 00
* Meyer's Determination of Radicles in Carbon Compounds. (Tingle).....	12mo,	1 25
Miller's Cyanide Process.....	12mo,	1 00
Manual of Assaying.....	12mo,	1 00
Minet's Production of Aluminum and its Industrial Use. (Waldo).....	12mo,	2 50
Mixer's Elementary Text-book of Chemistry.....	12mo,	1 50
Morgan's Elements of Physical Chemistry.....	12mo,	3 00
Outline of the Theory of Solutions and its Results.....	12mo,	1 00
* Physical Chemistry for Electrical Engineers.....	12mo,	1 50
Morse's Calculations used in Cane-sugar Factories.....	16mo. mor.	1 50
* Muir's History of Chemical Theories and Laws.....	8vo,	4 00
Mulliken's General Method for the Identification of Pure Organic Compounds.		
Vol. I.....	Large 8vo,	5 00
O'Driscoll's Notes on the Treatment of Gold Ores.....	8vo,	2 00
Ostwald's Conversations on Chemistry. Part One. (Ramsey).....	12mo,	1 50
" " " " Part Two. (Turnbull).....	12mo,	2 00
* Palmer's Practical Test Book of Chemistry.....	12mo,	1 00
* Pauli's Physical Chemistry in the Service of Medicine. (Fischer).....	12mo,	1 25
* Penfield's Notes on Determinative Mineralogy and Record of Mineral Tests.	8vo, paper,	50
Tables of Minerals, Including the Use of Minerals and Statistics of Domestic Production.....	8vo,	1 00
Pictet's Alkaloids and their Chemical Constitution. (Biddle).....	8vo,	5 00
Poole's Calorific Power of Fuels.....	8vo,	3 00
Prescott and Winslow's Elements of Water Bacteriology, with Special Reference to Sanitary Water Analysis.....	12mo,	1 50
* Reising's Guide to Piece-dyeing.....	8vo,	25 00
Richards and Woodman's Air, Water, and Food from a Sanitary Standpoint.....	8vo,	2 00
Ricketts and Miller's Notes on Assaying.....	8vo,	3 00
Rideal's Disinfection and the Preservation of Food.....	8vo,	4 00
Sewage and the Bacterial Purification of Sewage.....	8vo,	4 00

Hayford's Text-book of Geodetic Astronomy.	8vo,	3 00
Hering's Ready Reference Tables. (Conversion Factors).	16mo, mor.	2 50
Howe's Retaining Walls for Earth.	12mo,	1 25
* Ives's Adjustments of the Engineer's Transit and Level.	16mo, Bds.	25
Ives and Hilts's Problems in Surveying.	16mo, mor.	1 50
Johnson's (J. B.) Theory and Practice of Surveying.	Small 8vo,	4 00
Johnson's (L. J.) Statics by Algebraic and Graphic Methods.	8vo,	2 00
Kinnicutt, Winslow and Pratt's Purification of Sewage. (In Preparation.)		
Laplace's Philosophical Essay on Probabilities. (Truscott and Emory)	12mo,	2 00
Mahan's Descriptive Geometry.	8vo,	1 50
Treatise on Civil Engineering. (1873.) (Wood).	8vo,	5 00
Merriman's Elements of Precise Surveying and Geodesy.	8vo,	2 50
Merriman and Brooks's Handbook for Surveyors.	16mo, mor.	2 00
Nugent's Plane Surveying.	8vo,	3 50
Ogden's Sewer Construction.	8vo,	3 00
Sewer Design	12mo,	2 00
Parsons's Disposal of Municipal Refuse.	8vo,	2 00
Patton's Treatise on Civil Engineering.	8vo, half leather,	7 50
Reed's Topographical Drawing and Sketching	4to,	5 00
Rideal's Sewage and the Bacterial Purification of Sewage.	8vo,	4 00
Rijmer's Shaft-sinking under Difficult Conditions. (Corning and Peele).	8vo,	3 00
Siebert and Biggin's Modern Stone-cutting and Masonry.	8vo,	1 50
Smith's Manual of Topographical Drawing. (McMillan).	8vo,	2 50
Soper's Air and Ventilation of Subways	Large 12mo,	2 50
Tracy's Plane Surveying.	16mo, mor.	3 00
* Trautwine's Civil Engineer's Pocket-book.	16mo, mor.	5 00
Venable's Garbage Crematories in America.	8vo,	2 00
Methods and Devices for Bacterial Treatment of Sewage.	8vo,	3 00
Wait's Engineering and Architectural Jurisprudence.	8vo,	6 00
	Sheep,	6 50
Law of Contracts.	8vo,	3 00
Law of Operations Preliminary to Construction in Engineering and Architecture.	8vo,	5 00
	Sheep,	5 50
Warren's Stereotomy—Problems in Stone-cutting.	8vo,	2 50
* Waterbury's Vest-Pocket Hand-book of Mathematics for Engineers.		
	2 $\frac{7}{8}$ × 5 $\frac{3}{8}$ inches, mor.	1 00
Webb's Problems in the Use and Adjustment of Engineering Instruments.		
	16mo, mor.	1 25
Wilson's (H. N.) Topographic Surveying	8vo,	3 50
Wilson's (W. L.) Elements of Railroad Track and Construction.	12mo,	2 00

BRIDGES AND ROOFS.

Boller's Practical Treatise on the Construction of Iron Highway Bridges	8vo,	2 00
Burr and Falk's Design and Construction of Metallic Bridges	8vo,	5 00
Influence Lines for Bridge and Roof Computations.	8vo,	3 00
Du Bois's Mechanics of Engineering. Vol. II.	Small 4to,	10 00
Foster's Treatise on Wooden Trestle Bridges.	4to,	5 00
Fowler's Ordinary Foundations.	8vo,	3 50
French and Ives's Stereotomy.	8vo,	2 50
Greene's Arches in Wood, Iron, and Stone.	8vo,	2 50
Bridge Trusses.	8vo,	2 50
Roof Trusses.	8vo,	1 25
Grimm's Secondary Stresses in Bridge Trusses.	8vo,	2 50
Heller's Stresses in Structures and the Accompanying Deformations.	8vo,	3 00
Howe's Design of Simple Roof-trusses in Wood and Steel.	8vo,	2 00
Symmetrical Masonry Arches.	8vo,	2 50
Treatise on Arches.	8vo,	4 00

Johnson, Bry: 1, and Turneure's Theory and Practice in the Designing of Modern Framed Structures.....	Small 4to,	10 00
Merriman and Jacoby's Text-book on Roofs and Bridges:		
Part I. Stresses in Simple Trusses.....	8vo,	2 50
Part II. Graphic Statics.....	8vo,	2 50
Part III. Bridge Design.....	8vo,	2 50
Part IV. Higher Structures.....	8vo,	2 50
Morison's Memphis Bridge.....	Oblong 4to,	10 00
Sondericker's Graphic Statics, with Applications to Trusses, Beams, and Arches.		
	8vo,	2 00
Waddell's De Pontibus, Pocket-book for Bridge Engineers.....	16mo, mor,	2 00
* Specifications for Steel Bridges.....	12mo,	50
Waddell and Harrington's Bridge Engineering. (In Preparation.)		
Wright's Designing of Draw-spans. Two parts in one volume.....	8vo,	3 50

HYDRAULICS.

Barnes's Ice Formation.....	8vo,	3 00
Bazin's Experiments upon the Contraction of the Liquid Vein Issuing from an Orifice. (Trautwine).....	8vo,	2 00
Bovey's Treatise on Hydraulics.....	8vo,	5 00
Church's Diagrams of Mean Velocity of Water in Open Channels.		
	Oblong 4to, paper,	1 50
Hydraulic Motors.....	8vo,	2 00
Mechanics of Engineering.....	8vo,	6 00
Coffin's Graphical Solution of Hydraulic Problems.....	16mo, mor,	2 50
Flather's Dynamometers, and the Measurement of Power.....	12mo,	3 00
Folwell's Water-supply Engineering.....	8vo,	4 00
Frizell's Water-power.....	8vo,	5 00
Fuertes's Water and Public Health.....	12mo,	1 50
Water-filtration Works.....	12mo,	2 50
Ganguillet and Kutter's General Formula for the Uniform Flow of Water in Rivers and Other Channels. (Hering and Trautwine).....	8vo,	4 00
Hazen's Clean Water and How to Get It.....	Large 12mo,	1 50
Filtration of Public Water-supplies.....	8vo,	3 00
Hazlehurst's Towers and Tanks for Water-works.....	8vo,	2 50
Herschel's 115 Experiments on the Carrying Capacity of Large, Riveted, Metal Conduits.....	8vo,	2 00
Hoyt and Grover's River Discharge.....	8vo,	2 00
Hubbard and Kiersted's Water-works Management and Maintenance.....	8vo,	4 00
* Lyndon's Development and Electrical Distribution of Water Power.....	8vo,	3 00
Mason's Water-supply. (Considered Principally from a Sanitary Standpoint.)		
	8vo,	4 00
Merriman's Treatise on Hydraulics.....	8vo,	5 00
* Michie's Elements of Analytical Mechanics.....	8vo,	4 00
* Molitor's Hydraulics of Rivers, Weirs and Sluices.....	8vo,	2 00
Richards's Laboratory Notes on Industrial Water Analysis. (In Press).		
Schuyler's Reservoirs for Irrigation, Water-power, and Domestic Water-supply.....	Large 8vo,	5 00
* Thomas and Watt's Improvement of Rivers.....	4to,	6 00
Turneure and Russell's Public Water-supplies.....	8vo,	5 00
Wegmann's Design and Construction of Dams. 5th Ed., enlarged.....	4to,	6 00
Water-supply of the City of New York from 1658 to 1895.....	4to,	10 00
Whipple's Value of Pure Water.....	Large 12mo,	1 00
Williams and Hazen's Hydraulic Tables.....	8vo,	1 50
Wilson's Irrigation Engineering.....	Small 8vo,	4 00
Wolff's Windmill as a Prime Mover.....	8vo,	3 00
Wood's Elements of Analytical Mechanics.....	8vo,	3 00
Turbines.....	8vo,	2 50

MATERIALS OF ENGINEERING.

Baker's Roads and Pavements.	8vo,	5 00
Treatise on Masonry Construction.	8vo,	5 00
Birkmire's Architectural Iron and Steel.	8vo,	3 50
Compound Riveted Girders as Applied in Buildings.	8vo,	2 00
Black's United States Public Works	Oblong 4to,	5 00
Bleininger's Manufacture of Hydraulic Cement. (In Preparation.)		
* Bovey's Strength of Materials and Theory of Structures.	8vo,	7 50
Burr's Elasticity and Resistance of the Materials of Engineering.	8vo,	7 50
Byrne's Highway Construction.	8vo,	5 00
Inspection of the Materials and Workmanship Employed in Construction.		
	16mo,	3 00
Church's Mechanics of Engineering.	8vo,	6 00
Du Bois's Mechanics of Engineering.		
Vol. I. Kinematics, Statics, Kinetics.	Small 4to,	7 50
Vol. II. The Stresses in Framed Structures, Strength of Materials and Theory of Flexures.	Small 4to,	10 00
*Eckel's Cements, Limes, and Plasters.	8vo,	6 00
Stone and Clay Products used in Engineering. (In Preparation.)		
Fowler's Ordinary Foundations.	8vo,	3 50
Graves's Forest Mensuration.	8vo,	4 00
Green's Principles of American Forestry.	12mo,	1 50
* Greene's Structural Mechanics.	8vo,	2 50
Holly and Ladd's Analysis of Mixed Paints, Color Pigments and Varnishes		
	Large 12mo,	2 50
Johnson's (C. M.) Chemical Analysis of Special Steels. (In Preparation.)		
Johnson's (J. B.) Materials of Construction	Large 8vo,	6 00
Keep's Cast Iron.	8vo,	2 50
Kidder's Architects and Builders' Pocket-book.	16mo,	5 00
Lanza's Applied Mechanics.	8vo,	7 50
Maire's Modern Pigments and their Vehicles.	12mo,	2 00
Martens's Handbook on Testing Materials. (Henning) 2 vols.	8vo,	7 50
Maurer's Technical Mechanics.	8vo,	4 00
Merrill's Stones for Building and Decoration.	8vo,	5 00
Merriman's Mechanics of Materials.	8vo,	5 00
* Strength of Materials	12mo,	1 00
Metcalf's Steel. A Manual for Steel-users.	12mo,	2 00
Morrison's Highway Engineering	8vo,	2 50
Patton's Practical Treatise on Foundations.	8vo,	5 00
Rice's Concrete Block Manufacture.	8vo,	2 00
Richardson's Modern Asphalt Pavements.	8vo,	3 00
Riehy's Handbook for Superintendents of Construction.	16mo, mor,	4 00
* Ries's Clays: Their Occurrence, Properties, and Uses.	8vo,	5 00
Sabin's Industrial and Artistic Technology of Paints and Varnish.	8vo,	3 00
* Schwarz's Longleaf Pine in Virgin Forest.	12mo,	1 25
Snow's Principal Species of Wood.	8vo,	3 50
Spalding's Hydraulic Cement.	12mo,	2 00
Text-book on Roads and Pavements.	12mo,	2 00
Taylor and Thompson's Treatise on Concrete, Plain and Reinforced.	8vo,	5 00
Thurston's Materials of Engineering. In Three Parts.	8vo,	8 00
Part I. Non-metallic Materials of Engineering and Metallurgy.	8vo,	2 00
Part II. Iron and Steel.	8vo,	3 50
Part III. A Treatise on Brasses, Bronzes, and Other Alloys and their Constituents.	8vo,	2 50
Tillson's Street Pavements and Paving Materials.	8vo,	4 00
Turneaure and Maurer's Principles of Reinforced Concrete Construction.	8vo,	3 00
Waterbury's Cement Laboratory Manual.	12mo,	1 00

Wood's (De V.) Treatise on the Resistance of Materials, and an Appendix on the Preservation of Timber.	8vo,	2 00
Wood's (M. P.) Rustless Coatings: Corrosion and Electrolysis of Iron and Steel.	8vo,	4 00

RAILWAY ENGINEERING.

Andrews's Handbook for Street Railway Engineers	3x5 inches, mor.	1 25
Berg's Buildings and Structures of American Railroads	4to,	5 00
Brooks's Handbook of Street Railroad Location.	16mo, mor.	1 50
Batt's Civil Engineer's Field-book.	16mo, mor.	2 50
Crandall's Railway and Other Earthwork Tables.	8vo,	1 50
Transition Curve.	16mo, mor.	1 50
* Crockett's Methods for Earthwork Computations.	8vo,	1 50
Dawson's "Engineering" and Electric Traction Pocket-book.	16mo, mor.	5 00
Dredge's History of the Pennsylvania Railroad: (1879).	Paper,	5 00
Fisher's Table of Cubic Yards.	Cardboard,	25
Godwin's Railroad Engineers' Field-book and Explorers' Guide.	16mo, mor.	2 50
Hudson's Tables for Calculating the Cubic Contents of Excavations and Embankments.	8vo,	1 00
Ives and Hilts's Problems in Surveying, Railroad Surveying and Geodesy	16mo, mor.	1 50
Molitor and Beard's Manual for Resident Engineers.	16mo,	1 00
Nagle's Field Manual for Railroad Engineers.	16mo, mor.	3 00
Philbrick's Field Manual for Engineers.	16mo, mor.	3 00
Raymond's Railroad Engineering. 3 volumes.		
Vol. I. Railroad Field Geometry. (In Preparation.)		
Vol. II. Elements of Railroad Engineering.	8vo,	3 50
Vol. III. Railroad Engineer's Field Book. (In Preparation.)		
Searles's Field Engineering.	16mo, mor.	3 00
Railroad Spiral.	16mo, mor.	1 50
Taylor's Prismoïdal Formulæ and Earthwork.	8vo,	1 50
* Trautwine's Field Practice of Laying Out Circular Curves for Railroads.	12mo, mor.	2 50
* Method of Calculating the Cubic Contents of Excavations and Embankments by the Aid of Diagrams.	8vo,	2 00
Webb's Economics of Railroad Construction.	Large 12mo,	2 50
Railroad Construction.	16mo, mor.	5 00
Wellington's Economic Theory of the Location of Railways.	Small 8vo,	5 00

DRAWING.

Barr's Kinematics of Machinery.	8vo,	2 50
* Bartlett's Mechanical Drawing.	8vo,	3 00
* " " " Abridged Ed.	8vo,	1 50
Coolidge's Manual of Drawing.	8vo, paper,	1 00
Coolidge and Freeman's Elements of General Drafting for Mechanical Engineers.	Oblong 4to,	2 50
Durley's Kinematics of Machines.	8vo,	4 00
Emch's Introduction to Projective Geometry and its Applications.	8vo,	2 50
Hill's Text-book on Shades and Shadows, and Perspective.	8vo,	2 00
Jamison's Advanced Mechanical Drawing.	8vo,	2 00
Elements of Mechanical Drawing.	8vo,	2 50
Jones's Machine Design:		
Part I. Kinematics of Machinery.	8vo,	1 50
Part II. Form, Strength, and Proportions of Parts.	8vo,	3 00
MacCord's Elements of Descriptive Geometry.	8vo,	3 00
Kinematics; or, Practical Mechanism.	8vo,	5 00
Mechanical Drawing.	4to,	4 00
Velocity Diagrams.	8vo,	1 50

McLeod's Descriptive Geometry.....	Large 12mo,	1 50
* Mahan's Descriptive Geometry and Stone-cutting.....	8vo,	1 50
Industrial Drawing. (Thompson).....	8vo,	3 50
Moyer's Descriptive Geometry.....	8vo,	2 00
Reed's Topographical Drawing and Sketching.....	4to,	5 00
Reid's Course in Mechanical Drawing.....	8vo,	2 00
Text-book of Mechanical Drawing and Elementary Machine Design.....	8vo,	3 00
Robinson's Principles of Mechanism.....	8vo,	3 00
Schwamb and Merrill's Elements of Mechanism.....	8vo,	3 00
Smith's (R. S.) Manual of Topographical Drawing. (McMillan).....	8vo,	2 50
Smith (A. W.) and Marx's Machine Design.....	8vo,	3 00
* Titsworth's Elements of Mechanical Drawing.....	Oblong 8vo,	1 25
Warren's Drafting Instruments and Operations.....	12mo,	1 25
Elements of Descriptive Geometry, Shadows, and Perspective.....	8vo,	3 50
Elements of Machine Construction and Drawing.....	8vo,	7 50
Elements of Plane and Solid Free-hand Geometrical Drawing.....	12mo,	1 00
General Problems of Shades and Shadows.....	8vo,	3 00
Manual of Elementary Problems in the Linear Perspective of Form and Shadow.....	12mo,	1 00
Manual of Elementary Projection Drawing.....	12mo,	1 50
Plane Problems in Elementary Geometry.....	12mo,	1 25
Problems, Theorems, and Examples in Descriptive Geometry.....	8vo,	2 50
Weisbach's Kinematics and Power of Transmission. (Hermann and Klein).....	8vo,	5 00
Wilson's (H. M.) Topographic Surveying.....	8vo,	3 50
Wilson's (V. T.) Free-hand Lettering.....	8vo,	1 00
Free-hand Perspective.....	8vo,	2 50
Woolf's Elementary Course in Descriptive Geometry.....	Large 8vo,	3 00

ELECTRICITY AND PHYSICS.

* Abegg's Theory of Electrolytic Dissociation. (von Ende).....	12mo,	1 25
Andrews's Hand-Book for Street Railway Engineering.....	3×5 inches, mor.	1 25
Anthony and Brackett's Text-book of Physics. (Magie).....	Large 12mo,	3 00
Anthony's Theory of Electrical Measurements. (Ball).....	12mo,	1 00
Benjamin's History of Electricity.....	8vo,	3 00
Voltaic Cell.....	8vo,	3 00
Betts's Lead Refining and Electrolysis.....	8vo,	4 00
Classen's Quantitative Chemical Analysis by Electrolysis. (Boltwood).....	8vo,	3 00
* Collins's Manual of Wireless Telegraphy.....	12mo,	1 50
Mor.....	2 00	
Crehore and Squier's Polarizing Photo-chronograph.....	8vo,	3 00
* Danneel's Electrochemistry. (Merriam).....	12mo,	1 25
Dawson's "Engineering" and Electric Traction Pocket-book.....	16mo, mor.	5 00
Dolezalek's Theory of the Lead Accumulator (Storage Battery). (von Ende).....	12mo,	2 50
Duhem's Thermodynamics and Chemistry. (Burgess).....	8vo,	4 00
Flather's Dynamometers, and the Measurement of Power.....	12mo,	3 00
Gilbert's De Magnete. (Mottelay).....	8vo,	2 50
* Hanchett's Alternating Currents.....	12mo,	1 00
Hering's Ready Reference Tables (Conversion Factors).....	16mo, mor.	2 50
* Hobart and Ellis's High-speed Dynamo Electric Machinery.....	8vo,	6 00
Holman's Precision of Measurements.....	8vo,	2 00
Telescopic Mirror-scale Method, Adjustments, and Tests....	Large 8vc,	75
* Karapetoff's Experimental Electrical Engineering.....	8vo,	6 00
Kinzbrunner's Testing of Continuous-current Machines.....	8vo,	2 00
Landauer's Spectrum Analysis. (Tingle).....	8vo,	3 00
Le Chatelier's High-temperature Measurements. (Boudouard—Burgess).....	12mo,	3 00
Löb's Electrochemistry of Organic Compounds. (Lorenz).....	8vo,	3 00
* Lyndon's Development and Electrical Distribution of Water Power.....	8vo,	3 00

* Lyons's Treatise on Electromagnetic Phenomena. Vols. I. and II.	8vo, each,	6 00
* Michie's Elements of Wave Motion Relating to Sound and Light.	8vo,	4 00
Morgan's Outline of the Theory of Solution and its Results.	12mo,	1 00
* Physical Chemistry for Electrical Engineers.	12mo,	1 50
Niaudet's Elementary Treatise on Electric Batteries. (Fishback).	12mo,	2 50
* Norris's Introduction to the Study of Electrical Engineering.	8vo,	2 50
* Parshall and Hobart's Electric Machine Design.	4to, half mor.	12 50
Reagan's Locomotives: Simple, Compound, and Electric. New Edition.		
	Large 12mo,	3 50
* Rosenberg's Electrical Engineering. (Haldane Gee—Kinzbrunner).	8vo,	2 00
Ryan, Norris, and Hoxie's Electrical Machinery. Vol. I.	8vo,	2 50
Schapper's Laboratory Guide for Students in Physical Chemistry	12mo,	1 00
* Tillman's Elementary Lessons in Heat.	8vo,	1 50
Tory and Pitcher's Manual of Laboratory Physics.	Large 12mo,	2 00
Ulke's Modern Electrolytic Copper Refining.	8vo,	3 00

LAW.

Brennan's Handbook: A Compendium of Useful Legal Information for Business Men.	16mo, mor.	5 00
* Davis's Elements of Law.	8vo,	2 50
* Treatise on the Military Law of United States.	8vo,	7 00
*	Sheep,	7 50
* Dudley's Military Law and the Procedure of Courts-martial	Large 12mo,	2 50
Manual for Courts-martial.	16mo, mor.	1 50
Wait's Engineering and Architectural Jurisprudence.	8vo,	6 00
	Sheep,	6 50
Law of Contracts.	8vo,	3 00
Law of Operations Preliminary to Construction in Engineering and Archi- tecture.	8vo	5 00
	Sheep,	5 50

MATHEMATICS.

Baker's Elliptic Functions	8vo,	1 50
Briggs's Elements of Plane Analytic Geometry. (Bôcher).	12mo,	1 00
* Buchanan's Plane and Spherical Trigonometry.	8vo,	1 00
Byerley's Harmonic Functions.	8vo,	1 00
Chandler's Elements of the Infinitesimal Calculus.	12mo,	2 00
Coffin's Vector Analysis. (In Press.)		
Compton's Manual of Logarithmic Computations	12mo,	1 50
* Dickson's College Algebra	Large 12mo,	1 50
* Introduction to the Theory of Algebraic Equations	Large 12mo,	1 25
Emch's Introduction to Projective Geometry and its Applications	8vo,	2 50
Fiske's Functions of a Complex Variable.	8vo,	1 00
Halsted's Elementary Synthetic Geometry	8vo,	1 50
Elements of Geometry	8vo,	1 75
* Rational Geometry	12mo,	1 50
Hyde's Grassmann's Space Analysis.	8vo,	1 00
* Jonnson's (J. B.) Three-place Logarithmic Tables: Vest-pocket size, paper,		15
	100 copies,	5 00
*	Mounted on heavy cardboard, 8×10 inches,	25
	10 copies,	2 00
Johnson's (W. W.) Abridged Editions of Differential and Integral Calculus		
	Large 12mo, 1 vol.	2 50
Curve Tracing in Cartesian Co-ordinates	12mo,	1 00
Differential Equations.	8vo,	1 00
Elementary Treatise on Differential Calculus	Large 12mo,	1 50
Elementary Treatise on the Integral Calculus	Large 12mo,	1 50
* Theoretical Mechanics.	12mo,	3 00
Theory of Errors and the Method of Least Squares.	12mo,	1 50
Treatise on Differential Calculus.	Large 12mo,	3 00

Johnson's Treatise on the Integral Calculus.....	Large 12mo,	3 00
Treatise on Ordinary and Partial Differential Equations..	Large 12mo,	3 50
Karapetoff's Engineering Applications of Higher Mathematics. (In Preparation.)		
Laplace's Philosophical Essay on Probabilities. (Truscott and Emory)..	12mo,	2 00
* Ludlow and Bass's Elements of Trigonometry and Logarithmic and Other Tables8vo,	3 00
Trigonometry and Tables published separately	Each,	2 00
* Ludlow's Logarithmic and Trigonometric Tables8vo,	1 00
Macfarlane's Vector Analysis and Quaternions.....	.8vo,	1 00
McMahon's Hyperbolic Functions.....	.8vo,	1 00
Manning's Irrational Numbers and their Representation by Sequences and Series	12mo,	1 25
Mathematical Monographs. Edited by Mansfield Merriman and Robert S. Woodward.....	Octavo, each	1 00
No. 1. History of Modern Mathematics, by David Eugene Smith.		
No. 2. Synthetic Projective Geometry, by George Bruce Halsted.		
No. 3. Determinants, by Laenas Gifford Weld. No. 4. Hyperbolic Functions, by James McMahon. No. 5. Harmonic Functions, by William E. Byerly. No. 6. Grassmann's Space Analysis, by Edward W. Hyde. No. 7. Probability and Theory of Errors, by Robert S. Woodward. No. 8. Vector Analysis and Quaternions, by Alexander Macfarlane. No. 9. Differential Equations, by William Woolsey Johnson. No. 10. The Solution of Equations, by Mansfield Merriman. No. 11. Functions of a Complex Variable, by Thomas S. Fiske.		
Maurer's Technical Mechanics.....	.8vo,	4 00
Merriman's Method of Least Squares.....	.8vo,	2 00
Solution of Equations8vo,	1 00
Rice and Johnson's Differential and Integral Calculus. 2 vols. in one.		
	Large 12mo,	1 50
Elementary Treatise on the Differential Calculus.....	Large 12mo,	3 00
Smith's History of Modern Mathematics8vo,	1 00
* Veblen and Lennes's Introduction to the Real Infinitesimal Analysis of One Variable.....	.8vo,	2 00
* Waterbury's Vest Pocket Hand-Book of Mathematics for Engineers.		
	2 $\frac{7}{8}$ × 5 $\frac{3}{8}$ inches, mor.	1 00
Weld's Determinations.....	.8vo,	1 00
Wood's Elements of Co-ordinate Geometry.....	.8vo,	2 00
Woodward's Probability and Theory of Errors.....	.8vo,	1 00

MECHANICAL ENGINEERING.

MATERIALS OF ENGINEERING, STEAM-ENGINES AND BOILERS.

Bacon's Forge Practice.....	12mo,	1 50
Baldwin's Steam Heating for Buildings.....	12mo,	2 50
Barr's Kinematics of Machinery.....	.8vo,	2 50
* Bartlett's Mechanical Drawing.....	.8vo,	3 00
* " " " Abridged Ed.8vo,	1 50
Benjamin's Wrinkles and Recipes.....	12mo,	2 00
* Burr's Ancient and Modern Engineering and the Isthmian Canal.....	.8vo,	3 50
Carpenter's Experimental Engineering.....	.8vo,	6 00
Heating and Ventilating Buildings.....	.8vo,	4 00
Clerk's Gas and Oil Engine.....	Large 12mo,	4 00
Compton's First Lessons in Metal Working	12mo,	1 50
Compton and De Groodt's Speed Lathe.....	12mo,	1 50
Coolidge's Manual of Drawing.....	.8vo, paper,	1 00
Coolidge and Freeman's Elements of General Drafting for Mechanical Engineers.....	Oblong 4to,	2 50

Cromwell's Treatise on Belts and Pulleys.....	12mo,	1 50
Treatise on Toothed Gearing.....	12mo,	1 50
Durley's Kinematics of Machines.....	8vo,	4 00
Flather's Dynamometers and the Measurement of Power.....	12mo,	3 00
Rope Driving.....	12mo,	2 00
Gill's Gas and Fuel Analysis for Engineers.....	12mo,	1 25
Goss's Locomotive Sparks.....	8vo,	2 00
Greene's Pumping Machinery. (In Preparation.)		
Hering's Ready Reference Tables (Conversion Factors).....	16mo, mor.	2 50
* Hobart and Ellis's High Speed Dynamo Electric Machinery.....	8vo,	6 00
Hutton's Gas Engine.....	8vo,	5 00
Jamison's Advanced Mechanical Drawing.....	8vo,	2 00
Elements of Mechanical Drawing.....	8vo,	2 50
Jones's Gas Engine. (In Press.)		
Machine Design:		
Part I. Kinematics of Machinery.....	8vo,	1 50
Part II. Form, Strength, and Proportions of Parts.....	8vo,	3 00
Kent's Mechanical Engineers' Pocket-book.....	16mo, mor.	5 00
Kerr's Power and Power Transmission.....	8vo,	2 00
Leonard's Machine Shop Tools and Methods.....	8vo,	4 00
* Lorenz's Modern Refrigerating Machinery. (Pope, Haven, and Dean).....	8vo,	4 00
MacCord's Kinematics; or, Practical Mechanism.....	8vo,	5 00
Mechanical Drawing.....	4to,	4 00
Velocity Diagrams.....	8vo,	1 50
MacFarland's Standard Reduction Factors for Gases.....	8vo,	1 50
Mahan's Industrial Drawing. (Thompson).....	8vo,	3 50
Oberg's Screw Thread Systems, Taps, Dies, Cutters, and Reamers. (In Press.)		
* Parshall and Hobart's Electric Machine Design.....	Small 4to, half leather,	12 50
Peele's Compressed Air Plant for Mines.....	8vo,	3 00
Poole's Calorific Power of Fuels.....	8vo,	3 00
* Porter's Engineering Reminiscences, 1855 to 1882.....	8vo,	3 00
Reid's Course in Mechanical Drawing.....	8vo,	2 00
Text-book of Mechanical Drawing and Elementary Machine Design.....	8vo,	3 00
Richard's Compressed Air.....	12mo,	1 50
Robinson's Principles of Mechanism.....	8vo,	3 00
Schwamb and Merrill's Elements of Mechanism.....	8vo,	3 00
Smith's (O.) Press-working of Metals.....	8vo,	3 00
Smith (A. W.) and Marx's Machine Design.....	8vo,	3 00
Sorel's Carbureting and Combustion in Alcohol Engines. (Woodward and Preston).	Large 12mo,	3 00
Thurston's Animal as a Machine and Prime Motor, and the Laws of Energetics.	12mo,	1 00
Treatise on Friction and Lost Work in Machinery and Mill Work... 8vo,		3 00
Tillson's Complete Automobile Instructor.....	16mo,	1 50
	mor.	2 00
Titsworth's Elements of Mechanical Drawing.....	Oblong 8vo,	1 25
Warren's Elements of Machine Construction and Drawing.....	8vo,	7 50
* Waterbury's Vest Pocket Hand Book of Mathematics for Engineers.		
	2 $\frac{7}{8}$ × 5 $\frac{3}{8}$ inches, mor.	1 00
Weisbach's Kinematics and the Power of Transmission. (Herrmann—Klein).....	8vo,	5 00
Machinery of Transmission and Governors. (Herrmann—Klein).....	8vo,	5 00
Wood's Turbines.....	8vo,	2 50

MATERIALS OF ENGINEERING

* Bovey's Strength of Materials and Theory of Structures.....	8vo,	7 50
Burr's Elasticity and Resistance of the Materials of Engineering.....	8vo,	7 50
Church's Mechanics of Engineering.....	8vo,	6 00
* Greene's Structural Mechanics.....	8vo,	2 50

Holley and Ladd's Analysis of Mixed Paints, Color Pigments, and Varnishes.	Large 12mo,	2 50
Johnson's Materials of Construction.	8vo,	6 00
Keep's Cast Iron.8vo,	2 50
Lanza's Applied Mechanics.8vo,	7 50
Maire's Modern Pigments and their Vehicles.	12mo,	2 00
Martens's Handbook on Testing Materials. (Henning)8vo,	7 50
Maurer's Technical Mechanics.8vo,	4 00
Merriman's Mechanics of Materials.8vo,	5 00
* Strength of Materials	12mo,	1 00
Metcaif's Steel. A Manual for Steel-users.	12mo,	2 00
Sabin's Industrial and Artistic Technology of Paints and Varnish.8vo,	3 00
Smith's Materials of Machines.	12mo,	1 00
Thurston's Materials of Engineering.	3 vols., 8vo,	8 00
Part I. Non-metallic Materials of Engineering and Metallurgy.8vo,	2 00
Part II. Iron and Steel.8vo,	3 50
Part III. A Treatise on Brasses, Bronzes, and Other Alloys and their Constituents.8vo,	2 50
Wood's (De V.) Elements of Analytical Mechanics.8vo,	3 00
Treatise on the Resistance of Materials and an Appendix on the Preservation of Timber8vo,	2 00
Wood's (M. P.) Rustless Coatings: Corrosion and Electrolysis of Iron and Steel.8vo,	4 00

STEAM-ENGINES AND BOILERS.

Berry's Temperature-entropy Diagram.	12mo,	1 25
Carnot's Reflections on the Motive Power of Heat. (Thurston).	12mo,	1 50
Chase's Art of Pattern Making.	12mo,	2 50
Creighton's Steam-engine and other Heat-motors8vo,	5 00
Dawson's "Engineering" and Electric Traction Pocket-book.	16mo, mor.	5 00
Ford's Boiler Making for Boiler Makers.	18mo,	1 00
*Gebhardt's Steam Power Plant Engineering8vo,	6 00
Goss's Locomotive Performance.8vo,	5 00
Hemenway's Indicator Practice and Steam-engine Economy.	12mo,	2 00
Hutton's Heat and Heat-engines.8vo,	5 00
Mechanical Engineering of Power Plants.8vo,	5 00
Kent's Steam boiler Economy.8vo,	4 00
Kneass's Practice and Theory of the Injector.8vo,	1 50
MacCord's Slide-valves.8vo,	2 00
Meyer's Modern Locomotive Construction.	4to,	10 00
Moyer's Steam Turbines. (In Press.)		
Peabody's Manual of the Steam-engine Indicator.	12mo,	1 50
Tables of the Properties of Saturated Steam and Other Vapors.8vo,	1 00
Thermodynamics of the Steam-engine and Other Heat-engines.8vo,	5 00
Valve-gears for Steam-engines.8vo,	2 50
Peabody and Miller's Steam-boilers.8vo,	4 00
Pray's Twenty Years with the Indicator.	Large 8vo,	2 50
Pupin's Thermodynamics of Reversible Cycles in Gases and Saturated Vapors. (Osterberg).	12mo,	1 25
Reagan's Locomotives: Simple, Compound, and Electric. New Edition.	Large 12mo.	3 50
Sinclair's Locomotive Engine Running and Management.	12mo,	2 00
Smart's Handbook of Engineering Laboratory Practice.	12mo,	2 50
Snow's Steam-boiler Practice.8vo,	3 00
Spangler's Notes on Thermodynamics.	12mo,	1 00
Valve-gears.8vo,	2 50
Spangler, Greene, and Marshall's Elements of Steam-engineering8vo,	3 00
Thomas's Steam-turbines.8vo,	4 00

Thurston's Handbook of Engine and Boiler Trials, and the Use of the Indicator and the Prony Brake.	8vo,	5 00
Handy Tables.	8vo,	1 50
Manual of Steam-boilers, their Designs, Construction, and Operation.	8vo,	5 00
Thurston's Manual of the Steam-engine. 2 vols.	8vo,	10 00
Part I. History, Structure, and Theory.	8v,	6 00
Part II. Design, Construction, and Operation.	8vo,	6 00
Steam-boiler Explosions in Theory and in Practice.	12mo,	1 50
Wehrenfenning's Analysis and Softening of Boiler Feed-water (Patterson)	3vo,	4 00
Weisbach's Heat, Steam, and Steam-engines. (Du Bois)	8vo,	5 00
Whitham's Steam-engine Design.	8vo,	5 00
Wood's Thermodynamics, Heat Motors, and Refrigerating Machines.	8vo,	4 00

MECHANICS PURE AND APPLIED.

Church's Mechanics of Engineering.	8vo,	6 00
Notes and Examples in Mechanics.	8vo,	2 00
Dana's Text-book of Elementary Mechanics for Colleges and Schools.	12mo,	1 50
Du Bois's Elementary Principles of Mechanics:		
Vol. I. Kinematics.	8vo,	3 50
Vol. II. Statics.	8vo,	4 00
Mechanics of Engineering. Vol. I.	Small 4to,	7 50
Vol. II.	Small 4to,	10 00
* Greene's Structural Mechanics.	8vo,	2 50
James's Kinematics of a Point and the Rational Mechanics of a Particle.	Large 12mo,	2 00
* Johnson's (W. W.) Theoretical Mechanics.	12mo,	3 00
Lanza's Applied Mechanics.	8vo,	7 50
* Martin's Text Book on Mechanics, Vol. I, Statics.	12mo,	1 25
* Vol. 2, Kinematics and Kinetics	12mo,	1 50
Maurer's Technical Mechanics.	8vo,	4 00
* Merriman's Elements of Mechanics.	12mo,	1 00
Mechanics of Materials.	8vo,	5 00
* Michie's Elements of Analytical Mechanics.	8vo,	4 00
Robinson's Principles of Mechanism.	8vo,	3 00
Sanborn's Mechanics Problems.	Large 12mo,	1 50
Schwamb and Merrill's Elements of Mechanism.	8vo,	3 00
Wood's Elements of Analytical Mechanics.	8vo,	3 00
Principles of Elementary Mechanics.	12mo,	1 25

MEDICAL.

* Abderhalden's Physiological Chemistry in Thirty Lectures. (Hall and Defren)	8vo,	5 00
von Behring's Suppression of Tuberculosis. (Bolduan)	12mo,	1 00
* Bolduan's Immune Sera	12mo,	1 50
Bordet's Contribution to Immunity. (Gay). (In Preparation.)		
Davenport's Statistical Methods with Special Reference to Biological Variations.	16mo, mor.	1 50
Ehrlich's Collected Studies on Immunity. (Bolduan)	8vo,	6 00
* Fischer's Physiology of Alimentation.	Large 12mo, cloth,	2 00
de Fursac's Manual of Psychiatry. (Rosanoff and Collins)	Large 12mo,	2 50
Hammarsten's Text-book on Physiological Chemistry. (Mandel)	8vo,	4 00
Jackson's Directions for Laboratory Work in Physiological Chemistry	8vo,	1 25
Lassar-Cohn's Practical Urinary Analysis. (Lorenz)	12mo,	1 00
Mandel's Hand Book for the Bio-Chemical Laboratory	12mo,	1 50
* Pauli's Physical Chemistry in the Service of Medicine. (Fischer)	12mo,	1 25
* Pozzi-Escot's Toxins and Venoms and their Antibodies. (Cohn)	12mo,	1 00
Rostoski's Serum Diagnosis. (Bolduan)	12mo,	1 00
Ruddiman's Incompatibilities in Prescriptions.	8vo,	2 00
Whys in Pharmacy.	12mo,	1 00

Salkowski's Physiological and Pathological Chemistry. (Orndorff).....	8vo,	2	50
* Satterlee's Outlines of Human Embryology	12mo,	1	25
Smith's Lecture Notes on Chemistry for Dental Students.....	8vo,	2	50
Steel's Treatise on the Diseases of the Dog.....	8vo,	3	50
* Whipple's Typhoid Fever.....	Large 12mo,	3	00
Woodhull's Notes on Military Hygiene	16mo,	1	50
* Personal Hygiene.....	12mo,	1	00
Worcester and Atkinson's Small Hospitals Establishment and Maintenance, and Suggestions for Hospital Architecture, with Plans for a Small Hospital	12mo,	1	25

METALLURGY.

Betts's Lead Refining by Electrolysis	8vo,	4	00
Bolland's Encyclopedia of Founding and Dictionary of Foundry Terms Used in the Practice of Moulding	12mo,	3	00
Iron Founder	12mo,	2	50
" " Supplement	12mo,	2	50
Douglas's Untechnical Addresses on Technical Subjects.....	12mo,	1	00
Goesel's Minerals and Metals: A Reference Book	16mo, mor.	3	00
* Hies's Lead-smelting	12mo,	2	50
Keep's Cast Iron	8vo,	2	50
Le Chatelier's High-temperature Measurements. (Boudouard—Burgess).....	12mo,	3	00
Metcalf's Steel. A Manual for Steel-users	12mo,	2	00
Miller's Cyanide Process	12mo,	1	00
Minet's Production of Aluminium and its Industrial Use. (Waldo) ..	12mo,	2	50
Robine and Lenglen's Cyanide Industry. (Le Clerc).....	8vo,	4	00
Ruer's Elements of Metallography. (Mathewson) (In Press.).....			
Smith's Materials of Machines	12mo,	1	00
Tate and Stone's Foundry Practice. (In Press.).....			
Thurston's Materials of Engineering. In Three Parts	8vo,	8	00
Part I. Non-metallic Materials of Engineering and Metallurgy ..	8vo,	2	00
Part II. Iron and Steel	8vo,	3	50
Part III. A Treatise on Brasses, Bronzes, and Other Alloys and their Constituents.....	8vo,	2	50
Ulke's Modern Electrolytic Copper Refining	8vo,	3	00
West's American Foundry Practice	12mo,	2	50
Moulder's Text Book	12mo,	2	50
Wilson's Chlorination Process	12mo,	1	50
Cyanide Processes.....	12mo,	1	50

MINERALOGY.

Barringer's Description of Minerals of Commercial Value.....	Oblong, mor.	2	50
Boyd's Resources of Southwest Virginia.....	8vo,	3	00
Boyd's Map of Southwest Virginia.....	Pocket-book form.	2	00
* Browning's Introduction to the Rarer Elements.....	8vo,	1	50
Brush's Manual of Determinative Mineralogy. (Penfield).....	8vo,	4	00
Butler's Pocket Hand-Book of Minerals.....	16mo, mor.	3	00
Chester's Catalogue of Minerals.....	8vo, paper,	1	00
	Cloth,	1	25
* Crane's Gold and Silver.....	8vo,	5	00
Dana's First Appendix to Dana's New "System of Mineralogy.." ..	Large 8vo,	1	00
Manual of Mineralogy and Petrography.....	12mo	2	00
Minerals and How to Study Them	12mo.	1	50
System of Mineralogy.....	Large 8vo, half leather,	12	50
Text-book of Mineralogy.....	8vo,	4	00
Douglas's Untechnical Addresses on Technical Subjects.....	12mo,	1	00
Eakle's Mineral Tables.....	8vo,	1	25
Stone and Clay Products Used in Engineering. (In Preparation.)			

Egleston's Catalogue of Minerals and Synonyms.	8vo,	2 50
Goesel's Minerals and Metals: A Reference Book.	16mo, mor.	3 00
Groth's Introduction to Chemical Crystallography (Marshall)	12mo,	1 25
* Iddings's Rock Minerals	8vo,	5 00
Johannsen's Determination of Rock-forming Minerals in Thin Sections.	8vo,	4 00
* Martin's Laboratory Guide to Qualitative Analysis with the Blowpipe.	12mo,	60
Merrill's Non-metallic Minerals: Their Occurrence and Uses	8vo,	4 00
Stones for Building and Decoration.	8vo,	5 00
* Penfield's Notes on Determinative Mineralogy and Record of Mineral Tests.	8vo, paper,	50
Tables of Minerals, Including the Use of Minerals and Statistics of Domestic Production	8vo,	1 00
* Pirsson's Rocks and Rock Minerals	12mo,	2 50
* Richards's Synopsis of Mineral Characters.	12mo, mor.	1 25
* Ries's Clays: Their Occurrence, Properties, and Uses.	8vo,	5 00
* Tullman's Text-book of Important Minerals and Rocks.	8vo,	2 00

MINING.

* Beard's Mine Gases and Explosions.	Large 12mo,	3 00
Boyd's Map of Southwest Virginia.	Pocket-book form.	2 00
Resources of Southwest Virginia.	8vo,	3 00
* Crane's Gold and Silver	8vo,	5 00
Douglas's Untechnical Addresses on Technical Subjects.	12mo.	1 00
Eissler's Modern High Explosives.	8vo,	4 00
Goesel's Minerals and Metals: A Reference Book.	16mo, mor.	3 00
I Iseng's Manual of Mining.	8vo,	5 00
* Iles's Lead-smelting.	12mo,	2 50
Miller's Cyanide Process.	12mo,	1 00
O'Driscoll's Notes on the Treatment of Gold Ores.	8vo,	2 00
Peele's Compressed Air Plant for Mines	8vo,	3 00
Riemer's Shaft Sinking Under Difficult Conditions. (Corning and Peele)	8vo,	3 00
Robine and Lenglen's Cyanide Industry. (Le Clerc).	8vo,	4 00
* Weaver's Military Explosives.	8vo,	3 00
Wilson's Chlorination Process.	12mo,	1 50
Cyanide Processes.	12mo,	1 50
Hydraulic and Placer Mining. 2d edition, rewritten	12mo,	2 50
Treatise on Practical and Theoretical Mine Ventilation.	12mo,	1 25

SANITARY SCIENCE.

Association of State and National Food and Dairy Departments, Hartford Meeting, 1906	8vo,	3 00
Jamestown Meeting, 1907.	8vo,	3 00
* Bashore's Outlines of Practical Sanitation.	12mo,	1 25
Sanitation of a Country House.	12mo,	1 00
Sanitation of Recreation Camps and Parks.	12mo,	1 00
Folwell's Sewerage. (Designing, Construction, and Maintenance).. . . .	8vo,	3 00
Water-supply Engineering.	8vo,	4 00
Fowler's Sewage Works Analyses.	12mo,	2 00
Fuertes's Water-filtration Works.	12mo,	2 50
Water and Public Health.	12mo,	1 50
Gerhard's Guide to Sanitary House-inspection	16mo,	1 00
* Modern Baths and Bath Houses	8vo,	3 00
Sanitation of Public Buildings.	12mo,	1 50
Hazen's Clean Water and How to Get It.	Large 12mo,	1 50
Filtration of Public Water-supplies.	8vo,	3 00
Kinnicut, Winslow and Pratt's Purification of Sewage. (In Press.)		
Leach's Inspection and Analysis of Food with Special Reference to State Control.	8vo,	7 00

Mason's Examination of Water. (Chemical and Bacteriological).....	12mo,	1 25
Water-supply. (Considered Principally from a Sanitary Standpoint) ..	8vo,	4 00
* Merriman's Elements of Sanitary Engineering	8vo,	2 00
Ogden's Sewer Design.	12mo,	2 00
Parsons's Disposal of Municipal Refuse.....	8vo,	2 00
Prescott and Winslow's Elements of Water Bacteriology, with Special Reference to Sanitary Water Analysis.	12mo,	1 50
* Price's Handbook on Sanitation.	12mo,	1 50
Richards's Cost of Cleanness. A Twentieth Century Problem.....	12mo,	1 00
Cost of Food. A Study in Diaries.....	12mo,	1 00
Cost of Living as Modified by Sanitary Science.	12mo,	1 00
Cost of Shelter. A Study in Economics.....	12mo,	1 00
* Richards and Williams's Dietary Computer.....	8vo,	1 50
Richards and Woodman's Air, Water, and Food from a Sanitary Standpoint.	8vo,	2 00
Rideal's Disinfection and the Preservation of Food.	8vo,	4 00
Sewage and Bacterial Purification of Sewage.....	8vo,	4 00
Soper's Air and Ventilation of Subways	Large 12mo,	2 50
Turneure and Russell's Public Water-supplies.	8vo,	5 00
Venable's Garbage Crematories in America.....	8vo,	2 00
Method and Devices for Bacterial Treatment of Sewage.....	8vo,	3 00
Ward and Whipple's Freshwater Biology.....	12mo,	2 50
Whipple's Microscopy of Drinking-water.	8vo,	3 50
* Typhoid Fever.....	Large 12mo,	3 00
Value of Pure Water.	Large 12mo,	1 00
Winslow's Bacterial Classification.....	12mo,	2 50
Winton's Microscopy of Vegetable Foods.	8vo,	7 50

MISCELLANEOUS.

Emmons's Geological Guide-book of the Rocky Mountain Excursion of the International Congress of Geologists.....	Large 8vo,	1 50
Ferrel's Popular Treatise on the Winds.	8vo,	4 00
Fitzgerald's Boston Machinist	18mo,	1 00
Gannett's Statistical Abstract of the World.	24mo,	75
Haines's American Railway Management.	12mo,	2 50
* Hanusek's The Microscopy of Technical Products. (Winton).....	8vo,	5 00
Owen's The Dyeing and Cleaning of Textile Fabrics. (Standage). (In Press.)		
Ricketts's History of Rensselaer Polytechnic Institute 1824-1894.	Large 12mo,	3 00
Rotherham's Emphasized New Testament.	Large 8vo,	2 00
Standage's Decoration of Wood, Glass, Metal, etc.	12mo,	2 00
Thome's Structural and Physiological Botany. (Bennett).....	16mo,	2 25
Westermaier's Compendium of General Botany. (Schneider).....	8vo,	2 00
Winslow's Elements of Applied Microscopy.....	12mo,	1 50

HEBREW AND CHALDEE TEXT-BOOKS.

Green's Elementary Hebrew Grammar.....	12mo,	1 25
Gesenius's Hebrew and Chaldee Lexicon to the Old Testament Scriptures. (Tregelles).....	Small 4to: half mor.	5 00

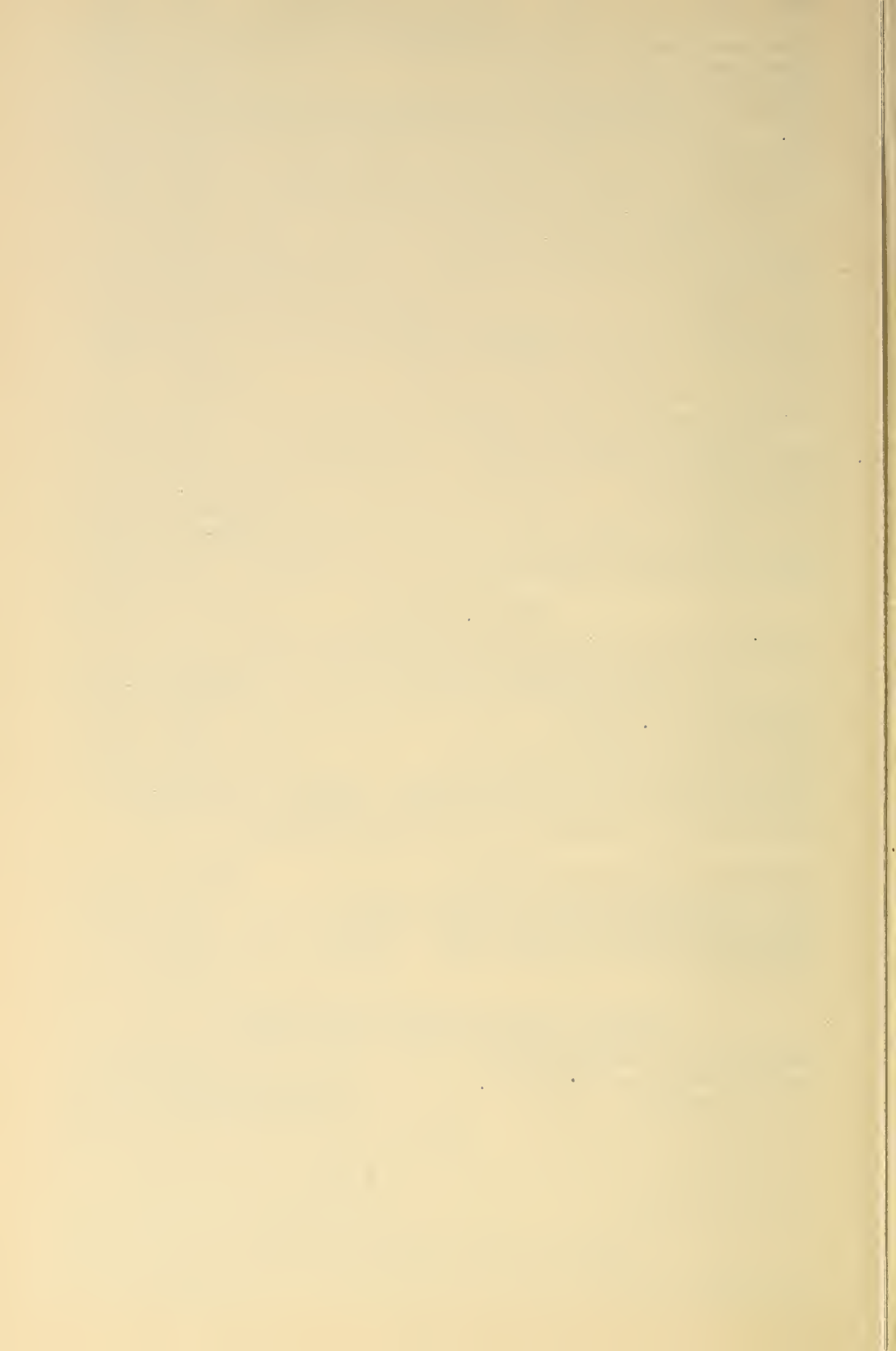





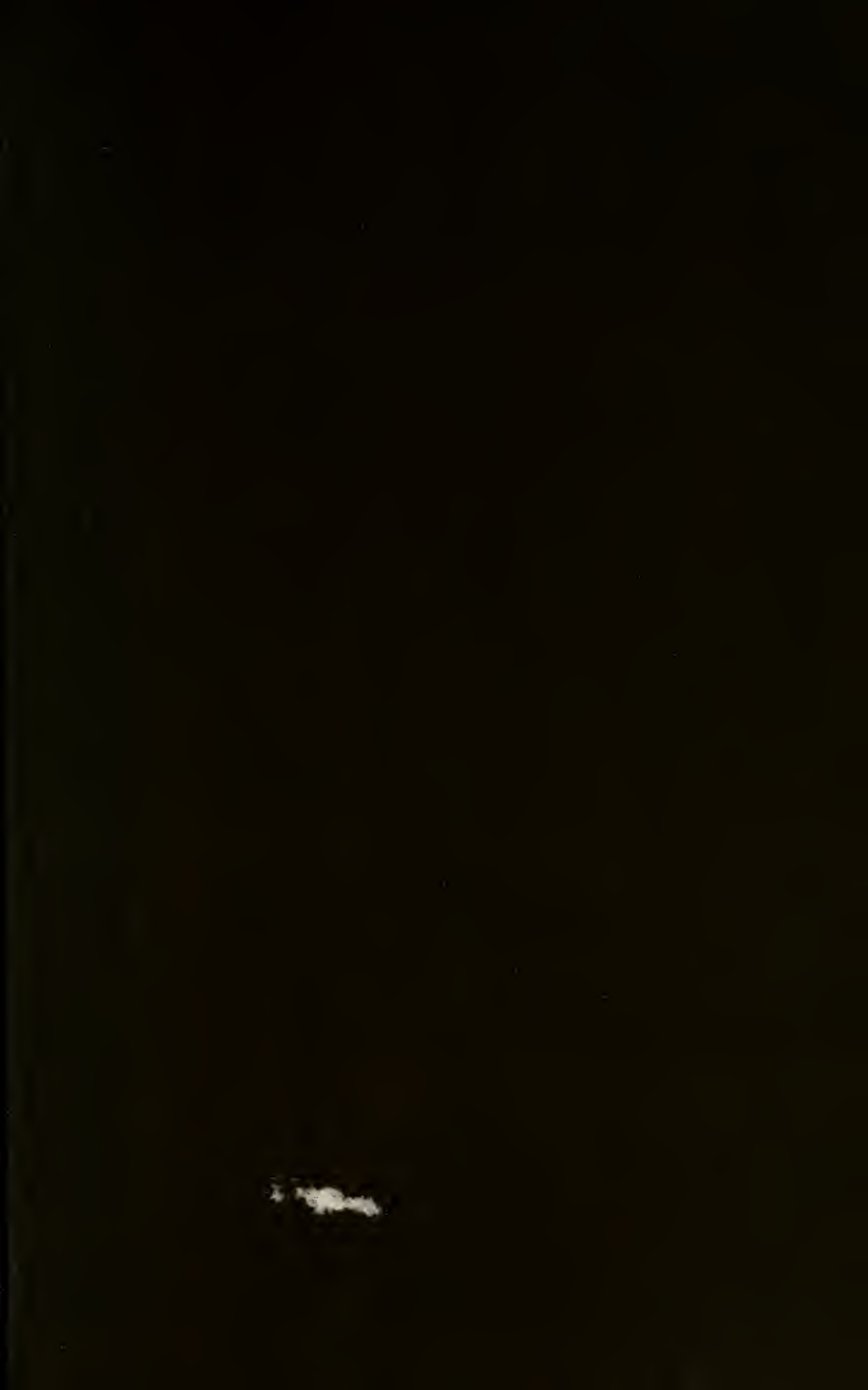

LIBRARY OF CONGRESS



0 003 333 170 8

