

Digitized by the Internet Archive  
in 2018 with funding from  
Getty Research Institute







# THE ARCHITECTURAL RECORD

AN ILLUSTRATED MONTHLY MAGAZINE OF ARCHITECTURE  
AND THE ALLIED ARTS AND CRAFTS.

---

## INDEX TO VOLUME XLVIII

---

JULY—DECEMBER

1920

---

PUBLISHED BY

THE ARCHITECTURAL RECORD CO.

115-119 WEST FORTIETH STREET, NEW YORK CITY

341 MONADNOCK BUILDING, CHICAGO  
BESSEMER BUILDING, PITTSBURGH

1821 CHESTNUT ST., PHILADELPHIA  
114 FEDERAL STREET, BOSTON



AR  
V. 48  
Cop. 2

Copyright, 1920, by THE ARCHITECTURAL RECORD CO.  
All Rights Reserved

1258



# THE ARCHITECTURAL RECORD

## INDEX

Volume XLVIII

July to December, 1920

### ARTICLES

PAGE

AMERICAN CHICLE COMPANY'S FACTORY, LONG ISLAND CITY, N. Y.: BALLINGER & PERROT, ARCHITECTS.....	553-556
AMERICAN COUNTRY HOUSE (THE).....	By Wm. Lawrence Bottomley. 258-368
BUILDING A NATION: SOCIAL ASPECTS OF ENGLAND'S HOUSING PROGRAM .....	By Lawrence Veiller.....407-416
CORTILE OF THE PALAZZO PERETTI, ROME, WITH DRAWINGS BY R. M. KENNEDY.....	By Harold Donaldson Eberlein, 107-120
DISPLAY ROOM OF THE ELLER MOTOR COMPANY, CLEVELAND, OHIO: PHILIP LINDSLEY SMALL, ARCHITECT.....	535-541
EARLY ARCHITECTURE OF PENNSYLVANIA (THE). PART I. By A. Lawrence Kocher.....	513-530
ENGLISH ARCHITECTURAL DECORATION. PART XV <sup>2</sup> . THE ADAM PERIOD .....	By Albert E. Bullock..... 39-51
ENGLISH ARCHITECTURAL DECORATION. PART XV <sup>3</sup> . THE ADAM PERIOD .....	By Albert E. Bullock.....224-235
GARDEN APARTMENTS IN CITIES. PART I.....	By John Taylor Boyd, Jr.... 52-74
GARDEN APARTMENTS IN CITIES. PART II.....	By John Taylor Boyd, Jr....121-135
HILLSIDE HOUSE, THE PROPERTY OF GEORGE HOWE, ESQ., CHESTNUT HILL, PHILADELPHIA, PA.: MELLOR, MEIGS & HOWE, ARCHITECTS .....	By Paul P. Cret..... 82-106
HOUSING SITUATION (THE) AND THE WAY OUT.....	By Lawrence Veiller.....531-534
IS IT ADVISABLE TO REMODEL SLUM TENEMENTS?.....	By Andrew J. Thomas.....417-424
	By Robert D. Kohn.....425-426
L'OMBRILLINO, NEAR FLORENCE, ITALY.....	By Harold Donaldson Eberlein, 441-451
MILLER STYLE INN, QUINCY, MASS.: FRANK B. WRIGHT, ARCHITECT; H. J. KELLAWAY, LANDSCAPE ARCHITECT. By	Sylvester Baxter..... 14-30
MUSEUMS, A BIBLIOGRAPHY OF.....	By Charles Over Cornelius..452-455
NEW YORK ZONING RESOLUTION AND ITS INFLUENCE UPON DESIGN .....	By John Taylor Boyd, Jr....192-217
OHIO STADIUM, AT OHIO STATE UNIVERSITY.....	By Howard Dwight Smith...385-406
PIDGEON HILL, RESIDENCE OF MEREDITH HARE, ESQ., HUNTINGTON, L. I.: CHARLES A. PLATT, ARCHITECT..	By Herbert Croly.....178-191
PRINCIPLES (SOME) OF SMALL HOUSE DESIGN. PART IX. INTERIORS (CONCLUDED).....	By John Taylor Boyd, Jr....242-256
PROPOSED VICTORY BRIDGE OVER THE HUDSON BETWEEN NEW YORK CITY AND WEEHAWKEN: ALFRED C. BOSSOM, ARCHITECT.....	By Robert Imlay.....218-223
RECENT CIVIC ARCHITECTURE IN PORTO RICO: ADRIAN F. FINLAYSON, ARCHITECT.....	By Sylvester Baxter.....136-158
RECENT DEVELOPMENTS IN HOUSING FINANCE. PART I..	By John Taylor Boyd, Jr....427-432
RECENT DEVELOPMENTS IN HOUSING FINANCE. PART II..	By John Taylor Boyd, Jr....542-549
RESIDENCE OF MRS. B. F. PEPPER, CHESTNUT HILL, PA.: WILLING & SIMS, ARCHITECTS.....	By Wm. Lawrence Bottomley.370-384
RIVERDALE COUNTRY CLUB, NEW YORK CITY: DWIGHT JAMES BAUM, ARCHITECT.....	By Michael A. Mikkelsen...433-440
SCULPTOR'S EXPERIMENT (A) IN THE DECORATION OF CONCRETE SURFACES.....	By Antoinette Ferrett..... 31-38

279

1 Jan. 1921

1030

	PAGE.
TURTLE BAY GARDENS, NEW YORK CITY: EDWARD C. DEAN AND WILLIAM LAWRENCE BOTTOMLEY, ASSOCIATE ARCHITECTS.....	By Arthur Willis Colton... 467-493
VILLA GALILEO (IL GIOIELLO), AT PIAN DE' GIULLARI, NEAR FLORENCE, ITALY.....	By Harold Donaldson Eberlein, 3
VILLA PAZZI (LA VACCHIA), PIAN DE' GIULLARI, NEAR FLORENCE, ITALY.....	By Harold Donaldson Eberlein, 495-511
WINNING DESIGNS IN THE COMPETITION FOR THE FELLOWSHIP IN ARCHITECTURE OF THE AMERICAN ACADEMY IN ROME.....	236-241

#### THE ARCHITECT'S LIBRARY.

BIBLIOGRAPHY OF MUSEUMS (A).....	By Charles Over Cornelius.. 452-455
COUSINS (FRANK) AND PHIL. M. RILEY: THE COLONIAL ARCHITECTURE OF SALEM.....	By Charles Over Cornelius.. 168
EBERLEIN (HAROLD DONALDSON), ABBOTT MCCLURE AND EDWARD STRATTON HOLLOWAY: THE PRACTICAL BOOK OF INTERIOR DECORATION.....	By Charles Over Cornelius.. 455
LOWELL (GUY): MORE SMALL ITALIAN VILLAS.....	By Charles Over Cornelius.. 168
WARREN (HERBERT LANGFORD): THE FOUNDATIONS OF CLASSIC ARCHITECTURE.....	By John Taylor Boyd, Jr... 166-168
WORKS (THE) OF AN ENGLISH CRITIC (LAWRENCE WEAVER) .....	By Charles Over Cornelius.. 551-552

#### NOTES AND COMMENTS.

##### *July:*

The Proposed Nebraska State Capitol. By Robert Imlay.....	75-78
Memorial Tablets. By John Taylor Boyd, Jr.....	78-80
Thrusts over Voids. By H. Van Buren Magonigle.....	80

##### *August:*

From an Address by Willis Polk Before the California School of Fine Arts.....	169
Old Hardware from Philadelphia and Annapolis. By Verna Cook Salomonsky....	169-173
The Architect's Signature on His Work. By Leon V. Solon.....	173-176

##### *November:*

A Jury of Artists Appraises the Architecture of Los Angeles. By John Taylor Boyd, Jr. ....	461-462
The Passing of a Unique Office Building. By I. T. Frary.....	462-464

##### *December:*

A Unique Moving Picture Theatre. By A. L. Black.....	557-560
--	---------

#### COVER DESIGNS.

##### *July:*

A Sketch in the Italian Majolica Style for American Faience.....	By Leon V. Solon
--	------------------

##### *August:*

A Design for a Faience Panel in the Persian Style.....	By Leon V. Solon
--	------------------

##### *September:*

A Design for Faience Garden Decoration.....	By Leon V. Solon
---	------------------

##### *October:*

A Water Color Drawing.....	By Jack Manley Rosé
----------------------------	---------------------

##### *November:*

The Ohio Stadium.....	By Howard Dwight Smith
-----------------------	------------------------

##### *December:*

A Terminal Motive in Turtle Bay Gardens.....	By Edward C. Dean
--	-------------------

TYPES OF BUILDINGS ILLUSTRATED.

PAGE.

APARTMENT HOUSES:

Garden Apartments, New York City.....	Henry Atterbury Smith and William P. Miller.....	66, 67
Garden Apartments, New York City.....	Clarence S. Stein.....	69, 71-73
Garden Apartments, New York City.....	George H. Wells.....	130-133
Garden Apartments, New York City.....	Andrew J. Thomas, 52-62, 63, 123, 125-129	

CAPITOLS:

Winning Design for Nebraska State Capitol.....	Bertram Grosvenor Goodhue..	76-78
--	-----------------------------	-------

CITY HALLS:

City Hall of Salinas, Porto Rico.....	Adrian C. Finlayson.....	150-151
---------------------------------------	--------------------------	---------

CLUBS:

Riverdale Country Club, New York City.....	Dwight James Baum.....	432-440
--	------------------------	---------

COMMERCIAL BUILDINGS:

Display Room of the Eller Motor Co., Cleveland, Ohio.....	Philip Lindsley Small.....	535-541
--	----------------------------	---------

DOMESTIC ARCHITECTURE:

Binnse, Henry B., Short Hills, N. J.....	Baillie Scott.....	345-352
Blaney Estate, Charles D., Saratoga, Cal.....	Willis Polk & Company.....	286-289
Clarke, William H., "Villa Virginia," Stockbridge, Mass.....	Hiss & Weekes.....	308-312
Coffin, T. R., San Marino, Cal.....	Reginald D. Johnson.....	332-334
Curran, Guernsey, Esq., Oyster Bay, L. I.....	Guy Lowell.....	324-331
Ehrman, Mrs. Alexis L., Atherton, Cal.....	Willis Polk & Company.....	459, 460
Flory, Walter, Cleveland, Ohio.....	Howell & Thomas.....	290-294
Ford, Todd, Jr., Pasadena, Cal.....	Reginald D. Johnson.....	340-344
Goodhue, Bertram Grosvenor, Montecito, Cal.....	Bertram Grosvenor Goodhue..	313-316
Goodwin, Philip L., Woodbury, L. I.....	Goodwin, Bullard & Woolsey..	274-285
Hare, Meredith, Huntington, L. I.....	Charles A. Platt.....	178-191
Howe, George, Chestnut Hill, Philadelphia, Pa....	Mellor, Meigs & Howe.....	82-105
Lindley, Willard P., Santa Barbara, Cal.....	George Washington Smith.....	361-365
Morris, Caspar W., Haverford, Pa.....	Mellor, Meigs & Howe.....	295-306
Orr, William Meade, Alhambra, Cal.....	Hunt & Burns.....	335-339
Pepper, Mrs. B. F., Chestnut Hill, Philadelphia Pa..	Willing & Sims.....	370-383
Sears, Philip, Brookline, Mass.....	Bigelow & Wadsworth.....	317-323
Smith, George Washington, Santa Barbara, Cal....	George Washington Smith, 258, 263-271	
Stout, Andrew V., Red Bank, N. J.....	John Russell Pope.....	353-360
Turtle Bay Gardens, New York City.....	Edward C. Dean and William Lawrence Bottomley.....	466-493

HOSPITALS:

Municipal Hospital in Fajardo, Porto Rico.....	Adrian C. Finlayson.....	154
--	--------------------------	-----

INDUSTRIAL BUILDINGS:

American Chiclé Co.'s Factory, Long Island City...	Ballinger & Perrot.....	553-556
--	-------------------------	---------

INNS:

Miller Stile Inn, Quincy, Mass.....	Frank B. Wright.....	14-30
-------------------------------------	----------------------	-------

LIBRARIES:

Library and Office Building of School Department, Mayaguez, Porto Rico.....	Adrian C. Finlayson.....	144
--	--------------------------	-----

MARKETS:

Municipal Market, Rio Piedras, Porto Rico.....	Adrian C. Finlayson.....	152-153
--	--------------------------	---------

OFFICE BUILDINGS:

Addition to New York Stock Exchange.....	Trowbridge & Livingston....	192
Cunard Building, New York City.....	Benjamin Wistar Morris.....	214-216
Fisk Building, New York City.....	Carrère & Hastings and R. H. Shreve.....	199-201

Liggett-Winchester-Ley Corporation Building, New York City.....	Carrère & Hastings and R. H. Shreve.....	195-197
--	---	---------

Madison Avenue Offices, New York City.....	Starrett & Van Vleck.....	211-213
National Association Building, New York City....	Starrett & Van Vleck.....	207-209
Park-Madison Building, New York City.....	Warren & Wetmore.....	203-205



SCHOOLS :	PAGE.
High School, Arecibo, Porto Rico..... Adrian C. Finlayson.....	147
High School, Mayaguez, Porto Rico..... Adrian C. Finlayson.....	146
Rafael Cordero Graded School, Barrio Santurce, San Juan, Porto Rico..... Adrian C. Finlayson.....	145
Rafael M. De Labra Graded School, Barrio San- turce, San Juan, Porto Rico..... Adrian C. Finlayson.....	142-143
Roman Baldorioty de Castro Graded and Technical School, San Juan, Porto Rico..... Adrian C. Finlayson.....	139-141
Rural School, Barrio Santana, Arecibo, Porto Rico.. Adrian C. Finlayson.....	148
Rural School, Barrio Poleol, Salinas..... Adrian C. Finlayson.....	136
Rural School in Luquillo, Porto Rico..... Adrian C. Finlayson.....	149
Twelve-Room School, Cayey, Porto Rico..... Adrian C. Finlayson.....	156, 157

STADIA :

Ohio Stadium, Ohio State University..... Joseph N. Bradford and Howard Dwight Smith.....	384-406
---	---------

TENEMENT HOUSES :

Plan for Rebuilding Block of New York Slum Tenements, Reserving 50% of the Site for Recreation Ground..... Andrew J. Thomas.....	421
--	-----

THEATRES :

Little Theatre, Santa Barbara, Cal..... Willis Polk & Co.....	456-458
Motion Picture Theatre, Scotia, Cal..... Alfred H. Jacobs.....	558-560

VILLAS AND PALACES, ITALIAN :

Cortile of the Palazzo Peretti, Rome.....	107-120
L'Ombrellino, at Pian de' Giullari, near Florence.....	441
Villa Galileo, at Pian de' Giullari, near Florence.....	2-13
Villa Pazzi, at Pian de' Giullari, near Florence.....	499-511

WORKMEN'S COTTAGES, ENGLISH :

London County Council Cottages at Hammersmith .....	407-416
---	---------

ARCHITECTS REPRESENTED.

NAME.	HOME OFFICE.	PAGE.
Ballinger & Perrot.....	New York City.....	553-556
Baum, Dwight James.....	New York City.....	432-440
Bigelow & Wadsworth.....	Boston, Mass.....	317-323
Bossom, Alfred C.....	New York City.....	218-222
Bottomley, William Lawrence.....	New York City.....	466-493
Bradford, Joseph N.....	Columbus, Ohio.....	384-404
Carrère & Hastings.....	New York City.....	195-201
Dean, Edward C.....	New York City.....	466-493
Finlayson, Adrian C.....	Porto Rico.....	136-158
Goodhue, Bertram Grosvenor.....	New York City.....	313-316
Goodwin,, Bullard & Woolsey.....	New York City.....	274-285
Hiss & Weckes.....	New York City.....	308-312
Hopkins, Alfred.....	New York City.....	250-251
Howell & Thomas.....	Cleveland, Ohio.....	290-294
Hunt & Burns.....	Los Angeles, Cal.....	335-339
Jacobs, Alfred H.....	San Francisco, Cal.....	558-560
Johnson, Reginald D.....	Pasadena, Cal.....	332-334, 340-344
Litchfield (Electus D.) & Rogers....	New York City.....	242-256
Lowell, Guy.....	Boston, Mass.....	324-331

NAME.	HOME OFFICE.	PAGE.
Mellor, Meigs & Howe.....	Philadelphia, Pa.....	82-105, 295-306
Miller, William P.....	New York City.....	66, 67
Morris, Benjamin Wistar.....	New York City.....	214-216
Murphy & Dana.....	New York City.....	58, 59, 244-249
Peabody, Wilson & Brown.....	New York City.....	252-254
Pickering, A. D.....	New York City.....	211-213
Platt, Charles A.....	New York City.....	178-191
Polk (Willis) & Co.....	San Francisco, Cal.....	286-289, 456-460
Pope, John Russell.....	New York City.....	352-360
Scott, Baillie.....	England.....	345-351
Shreve, R. H.....	New York City.....	195-201
Small, Philip Lindsley.....	Cleveland, Ohio.....	535-541
Smith, George Washington.....	Santa Barbara, Cal.....	258, 261-272, 361-365
Smith, Henry Atterbury.....	New York City.....	66, 67
Smith, Howard Dwight.....	Columbus, Ohio.....	384-404
Starrett & Van Vleck.....	New York City.....	207-213
Stein, Clarence S.....	New York City.....	69, 71-73
Thomas, Andrew J.....	New York City.....	52, 63, 64, 74, 123, 125-129, 421
Trowbridge & Livingston.....	New York City.....	192
Warren & Wetmore.....	New York City.....	203-205
Wells, George H.....	New York City.....	130-133
Willing & Sims.....	Philadelphia, Pa.....	370-383
Wright, Frank B.....		14-30

#### ILLUSTRATIONS OF DETAIL.

	PAGE.
Alcoves.....	46
Alée.....	449
Anterooms.....	312
Arcades.....	540, 591
Arches.....	466, 473
Balconies.....	484
Bedrooms.....	249, 270
Breakfast Porches.....	259
Bridges.....	158, 48-223
Ceilings.....	228, 229
Chimneypieces.....	95, 230
Courts and Courtyards.....	340, 445, 447
Dens.....	322
Dining Rooms.....	96, 189, 250, 256, 258, 312, 323, 331, 358, 380
Doors and Doorways, Exterior.....	50, 90, 127, 263, 292, 300, 318, 332, 357, 373, 499, 525
Doors and Doorways, Interior.....	49, 500
Drawing Rooms.....	266, 267, 364, 448
Fireplaces.....	94, 258, 330, 352, 359, 365, 439
Forecourts.....	86, 296, 311, 329
Fountains.....	35, 278, 338, 370, 469, 470, 471, 472, 474, 486
Gables.....	348
Gardens and Lawns.....	98, 110, 272, 328, 337, 339, 379, 477, 478, 509
Gates, Entrance.....	8, 261, 287
Grilles.....	302
Halls, Entrance.....	29, 91, 282, 293, 305, 320, 379
Halls, Living Room.....	47
Lamps, Wrought Iron.....	538

	PAGE.
Living Rooms.....	30, 93, 188, 242, 244, 253, 283, 299, 382, 501
Loggias .....	288, 343, 362, 473, 475, 488
Mantels .....	41-43, 227, 252, 525
Memorial Tablets.....	79
Models .....	65
Music Rooms.....	502, 505
Overmantels .....	44, 285
Panels and Paneling.....	232
Patio .....	335
Pergolas .....	469
Show Rooms, Automobile.....	537
Stairways .....	538, 539
Studios .....	269
Studys .....	97, 284, 295, 322
Towers .....	555
Vestibules, Entrance .....	536

#### SCULPTORS, DESIGNERS AND LANDSCAPE ARCHITECTS.

NAME.	HOME OFFICE.	PAGE.
Adams, Charles C.....		335-339
Kellaway, H. J.....	Boston, Mass.....	14-30
Mariano, John Di.....	New York City.....	159-166
Rumsey, Charles Cary.....	New York City.....	31-38



The  
ARCHITECTURAL  
RECORD

JULY 1920



PUBLISHED IN NEW YORK  
35¢ A COPY \$ 3.00 A YEAR



# The Stucco House of Superior Quality

## Is Built Throughout

### of Bishopric



BISHOPRIC built residence Southfield Pt., Stamford, Connecticut.

Architects: Dula & Patterson, New York.

STUCCO is smartest in style and unquestionably the most satisfactory type of house to build today. Stucco lends itself to artistic architectural effects in greater variety than any other form of building construction. The Stucco house is a practical success, also, even when built by old fashioned methods. Since the invention of BISHOPRIC, however, the stucco house has truly become the house de luxe in every quality that goes to make the ideal home.

A stucco house built of BISHOPRIC is enduring. It will last for generations with no "cost of upkeep." It has extraordinary strength and is impregnable against that insidious yet most dangerous foe to good housing—moisture. Moisture shortens the life of most buildings and imperils the health of the occupants.

A home is a place in which to live—to be comfortable, to sleep and rest and entertain—in which to raise children in health and happiness.

A stucco house, built throughout of BISHOPRIC, as illustrated in sketch at the side, provides the utmost maximum, within practicable limits, of comfort. A study of this drawing, showing the three layers of asphalt mastic in the walls and the two layers of dead air space (the best method of insulation known to builders) and the super-excellent combination of asphalt and dead air space insulation of the floors and ceilings indicates how impossible it is for moisture to circulate. There is no danger of dampness causing plaster to fall, nor is there any annoyance from the transmission of noise from street to house, floor to floor, room to room. Warmth is kept inside in winter and heat outside in summer by reason of those double walls of dead air space and those triple walls of sound-deadening, weatherproof asphalt mastic.

While BISHOPRIC was designed first for superiority, actual practice has proved that a BISHOPRIC built house costs decidedly less than stucco and frame houses built by old-fashioned methods. We have prepared a booklet for you, containing facts and figures, and illustrated with photographs of beautiful houses built with Bishopric stucco, plaster and sheathing units. Ask for it.

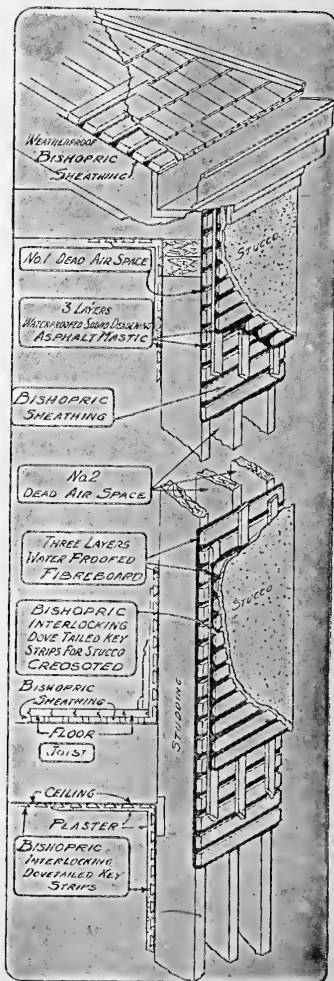

BISHOPRIC Manufacturing Co.

102 Este Ave., Cincinnati, O.

# THE ARCHITECTURAL RECORD



Vol. XLVIII. No. 1

JULY, 1920

Serial No. 262

*Editor:* MICHAEL A. MIKKELSEN    *Contributing Editor:* HERBERT CROLY  
*Business Manager:* J. A. OAKLEY

COVER—A Sketch in the Italian Majolica Style for American Faience <i>By Leon V. Solon</i>	PAGE 3
THE VILLA GALILEO (Il Giojello), at Pian De' Giullari, near Florence, Italy <i>By Harold Donaldson Eberlein</i>	3
THE MILLER STILE INN, Quincy, Mass.: Frank B. Wright, Architect; H. J. Kellaway, Landscape Architect <i>By Sylvester Baxter</i>	15
A SCULPTOR'S EXPERIMENT IN THE DECORATION OF CONCRETE SURFACES <i>By Antoinette Perrett</i>	31
ENGLISH ARCHITECTURAL DECORATION. Part XV <sub>2</sub> . The Adam Period (Continued) <i>By Albert E. Bullock</i>	39
GARDEN APARTMENTS IN CITIES <i>By John Taylor Boyd, Jr.</i>	52
NOTES AND COMMENTS	78

*Yearly Subscription: United States, \$3.00; Foreign, \$4.00; Single Copies, 35 cents. Copyright, 1920, by The Architectural Record Co. All rights reserved. Member Audit Bureau of Circulation.*

PUBLISHED MONTHLY BY  
**THE ARCHITECTURAL RECORD COMPANY**

115-119 WEST FORTIETH STREET, NEW YORK

T. S. MORGAN, Pres.    W. D. HADSELL, Vice-Pres.    E. S. DODGE, Vice-Pres.    J. W. FRANK, Sec'y-Treas.





NORTHWEST SIDE—VILLA GALILEO, PIAN  
DE' GIULLARI, NEAR FLORENCE, ITALY.

# THE ARCHITECTURAL RECORD

VOLUME XLVIII



NUMBER I

JULY, 1920

## *The Villa Galileo (Il Giojello), at Pian De' Giullari, near Florence, Italy*



*By*

*Harold Donaldson Eberlein*

**I**L GIOJELLO, more commonly known as the Villa Galileo, is several miles to the south of Florence, in the little hill village of Pian de' Giullari. It is recorded that at the end of the fourteenth century the villa belonged to the Masi family of Florence. At the end of the fifteenth century it was sold to the Calderini, and again by them, in 1559, to the Cavalcanti.

Subsequently it passed through various hands, until, on November 1, 1631, Galileo came there to live. Thither came John Milton to visit him in his last years, and there, on November 1, 1642, he died. A marble bust of Galileo has been placed in a niche in the wall on

the road front, and a tablet beneath commemorates Galileo's occupancy and Milton's visit. Since Galileo's day no changes in the structure have taken place.

As the plans show, the house is built about three sides of an oblong cortile, the fourth being enclosed by a wall. The ground floor of the southeast wing was originally a loggia, just as the first floor space above it still is, but was enclosed at an early date to make additional rooms. A larger loggia extends towards the northeast and shuts in the rear of the villa from the road. The small windows, like portholes in the north wall, light the staircases and cupboards. The walls are of grey stucco and the window



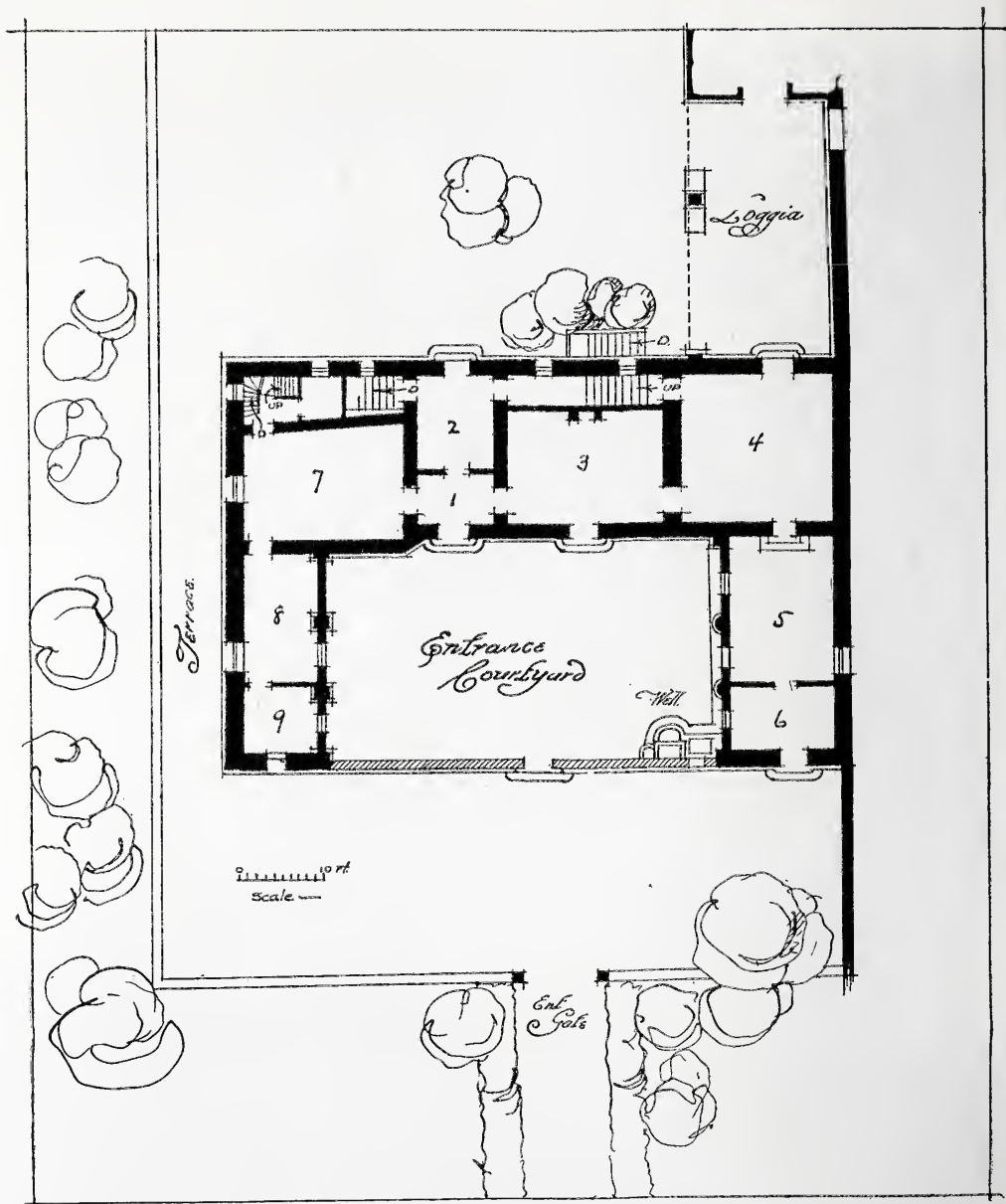

GROUND FLOOR PLAN AND GARDEN LAYOUT—VILLA GALILEO, PIAN DE' GIULLARI, NEAR FLORENCE, ITALY.



SOUTHEAST FRONT—VILLA GALILEO, PIAN DE' GIULLARI, NEAR FLORENCE, ITALY.



ENTRANCE TO CORTILE FROM  
GARDEN—VILLA GALILEO, PIAN DE'  
GIULLARI, NEAR FLORENCE, ITALY.





WITHIN THE CORTILE—VILLA GALILEO, PIAN  
DE' GIULLARI, NEAR FLORENCE, ITALY.





GATE OF THE CORTILE—VILLA GALILEO,  
PIAN DE' GIULLARI, NEAR FLORENCE, ITALY.



SOUTHEAST END OF CORTILE, WITH  
WELL—VILLA GALILEO, PIAN DE'  
GIULLARI, NEAR FLORENCE, ITALY.





NORTHWEST END OF CORTILE--VILLA GALILEO,  
PIAN DE' GIULLARI, NEAR FLORENCE, ITALY.





SOUTH ANGLE OF CORTILE—VILLA GALILEO, PIAN DE' GIULLARI, NEAR FLORENCE, ITALY.



NORTH ANGLE OF CORTILE—VILLA GALILEO, PIAN DE' GIULLARI, NEAR FLORENCE, ITALY.



NORTHWEST SIDE—VILLA GALILEO, PIAN  
DE' GIULLARI, NEAR FLORENCE, ITALY.





NORTHEAST SIDE—VILLA GALILEO, PIAN DE' GIULLARI, ITALY.

and door trims are of the close-grained grey *pietra serena* quarried at Fiesole. In surface the stucco is smooth and easily coated with wash. The shutters are light green in color.

There is very little garden space attached to Il Giojello—only the small formal plot enclosed by the cortile and a small stretch beyond the cortile wall along the path going down to the *portiere's* lodge beside the gate. Elsewhere the olive orchards and vineyards come close up to the house, as may be seen by the views of the terrace along the northwest side. It should be noted that the well in the corner of the cortile is so arranged that the *contadini* may come and draw

water without coming inside the cortile. The ceilings of the ground floor rooms are vaulted, and the corbels at the springs of the vaultings are of simple but exceedingly vigorous design. As is customary, the floors are paved with brick and painted. The kitchen is in the basement, and the room numbered 2 is really more of a serving room than a kitchen, although cooking may be done therein.

The following is a list of the uses of the ground floor rooms:

(1) Vestibule; (2) serving room; (3) dining room; (4) drawing room or *salone grande*; (5) music room; (6) ante room; (7) living room; (8) library; and (9) private study.



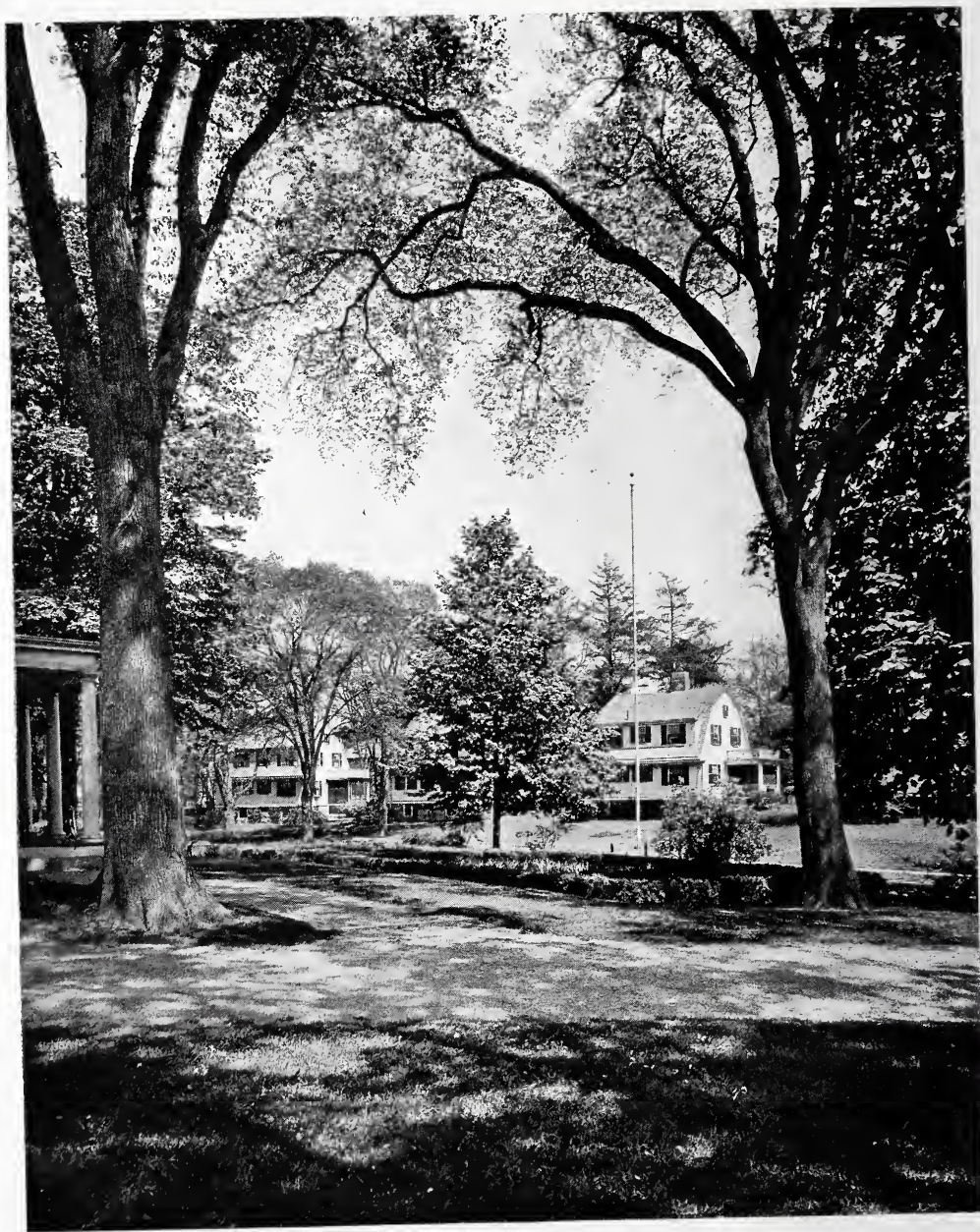

VIEW OF COTTAGES THROUGH ELMS FROM  
INN — MILLER STILE INN, QUINCY, MASS.

# *The Miller Stile Inn, Quincy, Mass.*

*Frank B. Wright, Architect*  
*H. J. Kellaway, Landscape Architect*

*By Sylvester Baxter*

**D**ROPPING in for dinner, pot-luck fashion, with an old friend (a prosperous business man, partner in a prominent firm of bankers and brokers) I found his wife's seat still vacant when we were called to the table. So we waited a minute or two. When she joined us she entered by way of the butler's pantry. She had been getting the dinner!

The cook, who had been with the family several years, attached to all the household after the fashion of old-style "help," had gone away to be married and the second-girl had left. It was a good dinner. Happily my friend's wife, although born in luxury, her father a several-times millionaire, was one of the common-sense sort and had been brought up in level-headed, democratic American fashion—trained in all the domestic activities of a typical New England breeding. The adolescent son, a handsome, clean-cut manly youth, acted as butler and helped bring in the courses. I wonder if that is not the kind of attention that one should most appreciate—attention given in friendly concern for the comfort of a guest, attention from a member of the family who "helps" in the household duties, just as in the average home in the good old New England days there were no servants in the modern sense, but members of some friendly neighbor's family who joined in helping carry on the household.

When democracy has been made safe for the world that must be what we are coming to. Even in the highly prosperous families, the sons and the daughters will all share in looking after everything needed to keep the home going, just as farmers' sons and daughters do. This would not solve the problem in all cases,

of course. There might be no children to help, or the children might be too young, or they might be grown up and married off. But will not the conditions attending domestic service be so changed that a quite different grade of help, socially our equals, will then be the only sort available? The difficulties that now make the problem so troublesome will then disappear. Class distinction, based upon differences in standards of life, of manners, and in degrees of cultivation, is what now makes the trouble.

The time must come when domestic service as a vocation stands upon a footing comparable with that of a trained nurse: something likewise demanding special training and commanding respect. The calling is in such social repute that members of our "first families" enter into it both because they incline to it and because it is "the thing to do." And yet the trained nurse does things in the way of intimate daily service so essentially distasteful that nothing in the domestic servant's line of duties can be compared with them in the way of "meniality." And nobody thinks the less of a trained nurse on that account.

All this is what we are coming to. We shall be forced into it by the increased cost of living and its corollary, the acuteness of the domestic service problem. Meanwhile thousands of prosperous households are up against it; people who had always been used to taking life easy and concerned themselves little with household tasks so far as participation is concerned.

The friends I mentioned in beginning live in a typical city house, of the sort inhabited by a family of that class, a large dwelling of four stories, generous in frontage, with several bathrooms, and



the like. Naturally it is impracticable to look after a house of that kind without good domestic service. Yet it was extremely difficult to get it. "It is humiliating beyond endurance to go to an intelligence-office," said my hostess. "To act the suppliant, to be looked over in superior fashion, and have the maid in effect dismiss my case with a top-lofty 'you-won't-do' sort of air." My hostess had too much breeding ever to have adopted such an attitude towards servants; to have servants assume such airs was more than she could stand. And even second-maids would consider nothing less than fourteen dollars a week!

People will have to put up with smaller, more compact houses than they used to. Even a millionaire's income will hardly, at the present rates of wages and costs, stand living in a house that demands more than three or four servants; that is, a one-millionaire, a "mono-

millionaire," so to speak. The semi-millionaire will have to put up with two or three; the man with five thousand a year can hardly stand one—if he can that.

The dearth of servants is so great that families are driven in swarms to live in apartment houses; others are resorting to hotels to an extent that hostelries hitherto devoted chiefly to transients are now almost monopolized by permanent guests. But only childless couples can properly live in hotels; indeed, while they may exist in a hotel in great comfort they can hardly be said to *live* there, so far as that which makes for so great a part of life is concerned: the home. There is little of the home in a hotel. There is more of it, of course, in a first class apartment house, where people of all grades of income may live cosily and comfortably, and with a minimum of work. Some of the best modern apart-

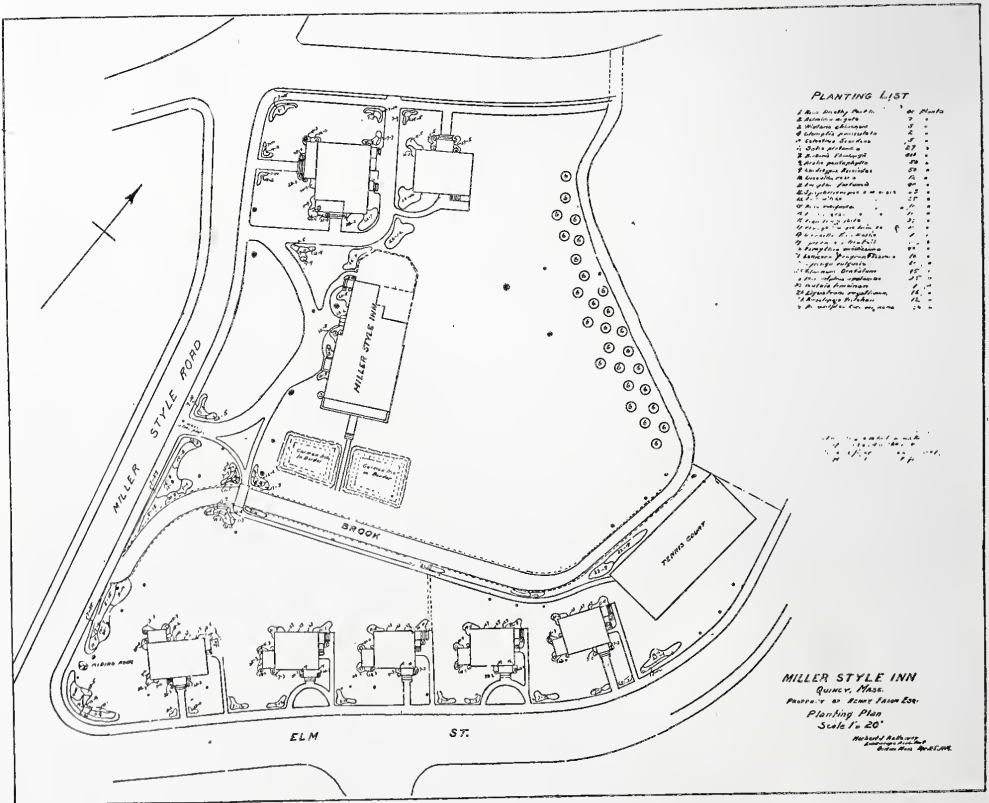





FRONT VIEW—MILLER STILE INN, QUINCY, MASS.

ments are now designed entirely without servants' rooms, dependence being had on help that lives outside and comes in for the day. A most homelike apartment house that I know in Cambridge has an attractive feature in the way of spacious grounds in the rear, with a good lawn bordered by little allotment gardens where each tenant family may grow its own flowers or vegetables.

But an apartment is no place for children who are to grow up normally. An architect friend, who is blessed with a goodly family brought up under the desirable conditions of a delightful home in an outer suburb with wide expanses of open country, told me how, for the sake of convenience to business, lightening of the cares of housekeeping for the wife, the enjoyment of theatres, concerts, etc., he had last year taken an apartment for the inclement months. "But never again," said he. The children, kept under

the endless restraint, could not be reconciled to an urban environment under the pent-up circumstances of life in a flat, even though commodious for its sort, and comfortable. It was like attempting to grow plants in a cellar or to raise a colt in a box-stall.

The whole problem is so new, the new conditions have arisen so suddenly, that instances of successful attempts at dealing with it are comparatively few as yet, and material for illustration is correspondingly scarce. One method of reducing the household cares, dispensing with the necessity of servants or at any rate reducing their number to a minimum of perhaps one, and thereby diminish the size and cost of the house, is to build detached dwellings in groups around a central establishment, which might be a tavern, a refectory, or clubhouse. This could be run either co-operatively, or as a business venture, or



DETAIL OF PORCH AND DOOR OF INN  
—MILLER STILE INN, QUINCY, MASS.





SIDE VIEW FROM MILLER STILE ROAD  
--MILLER STILE INN, QUINCY, MASS.





VIEW OF INN FROM REAR, SHOWING  
ANNEX—MILLER STILE INN, QUINCY, MASS.





ANNEX, WITH INN IN THE BACK-GROUND—MILLER-STILE INN, QUINCY, MASS.





VIEW FROM INN VERANDA—  
MILLER STILE INN, QUINCY, MASS.





ANNEX AND COTTAGES—MILLER  
STILE INN, QUINCY, MASS.





COTTAGES THROUGH TREES FROM RUSTIC  
BRIDGE—MILLER STILE INN, QUINCY, MASS.





REAR VIEW OF COTTAGES—  
MILLER STILE INN, QUINCY, MASS.





SUITE ON FIRST FLOOR OF INN—MILLER STILE INN, QUINCY, MASS.



SITTING ROOM OF INN—MILLER STILE INN, QUINCY, MASS.

by the landlord of the property in case the houses grouped around were under common ownership and let to tenants instead of individually owned. Meals might be sent in from the central kitchen in case there were no café or restaurant connected with it. This would meet the needs of invalids or others for whom it might not be practicable to go outside for meals. Or there might be open peristyle or corridor connections between the separate houses and the central building—after the fashion of connecting outlying wards of a modern hospital with the administration building. These connections would be protected from inclement weather by windows, either removable in summer or so designed as to be raised or lowered. They would naturally be capable of most attractive architectural treatment, either as elaborately as might be demanded, or for sake of economy kept very simple—perhaps metallic structural work with roll-up curtains or venetian blinds.

This system would be an application to individual detached dwellings of the plan whereby a large apartment house has its café for the convenience of tenants. It simply adapts to permanent home conditions the summer camp idea; or that of the summer hotel with its group of outlying cottages, like chickens clustered about a mother hen. Obviously space in a house designed in connection with such a feature could be greatly economized. Servants' rooms would either be dispensed with or reduced in number; also the kitchen, and possibly even the dining-room. But guard should be taken against the dying out of the good old traditions of house-keeping, whereby individuality in diet is maintained in the preparation of attractive dishes, special dainties in the way of desserts, jams, jellies, and the like, so dear to the housewifely heart and the palates of her family. So at least a kitchenette should be provided for; it would be a pity to lose all this precious heritage in family life to be replaced by the standardized menus so monotonous and dispiriting in hotel and restaurant life. Much can probably be successfully

done along the lines suggested in the foregoing under adequate co-operation. And co-operation will doubtless play an increasingly important part in our future industrial and social developments.

A most attractive example of this sort of development is that made within a few years by Mr. Henry M. Faxon of Quincy, Massachusetts. Certain aspects of that historic South-Shore suburb of Boston were touched upon in my article on the Fore River industrial housing development (*Architectural Record* for March, 1919). Quincy has been uncommonly fortunate in developing along lines that avoid many of the objectionable features so common to modern industrial growth. For instance, the Greater Boston environment, like that of Greater New York, is cursed by the prevalence of wooden "three-deckers." Vast areas in the Roxbury and Dorchester districts, once highly attractive residentially, have been covered with these obnoxious dwellings, depreciating rapidly and a constant menace to public safety in inviting the conflagration that seems bound some day to occur. Even so advanced a municipality as Brookline has permitted this infliction. More recently other Greater Boston suburbs have adopted regulations forbidding such constructions in future. But too often it has been like locking the stable door after the horse is stolen. Quincy, however, took time by the forelock and barred out the three-decker entirely before any had chanced to be built—almost a wonder in so rapidly growing an industrial city with a corresponding demand for houses. In consequence the place combines, as few suburbs of a great city do, much high-class residential attractiveness with a rapid suburban development. The stately traditions of old New England Colonial families survive in the aspect of the place, and much has been done for the community in a public-spirited way, as, for instance, in the gift of a beautiful seaside pleasure-ground, Merrymount Park, by the late Charles Francis Adams.

A few years ago an old Colonial property in the midst of one of the best residential districts came into the mar-





REAR VIEW OF ONE OF THE COTTAGES  
—MILLER STILE INN, QUINCY, MASS.



ket and was purchased by Mr. Faxon. Being not far from the business center a property so located might in undesirable hands have been liable to a correspondingly undesirable development. Mr. Faxon, however, took a course that main-

later, as town-planner, so successfully designed the layout for the Fore River industrial housing project of the United States Housing Corporation in Quincy, was commissioned with making a suitable plan for developing the place in



HALL IN ONE OF THE COTTAGES—MILLER STILE INN, QUINCY, MASS.

tained the character of the neighborhood. The fine old Colonial house had been built by Chief Justice Miller, of the Massachusetts Supreme Court. Later it became the William Everett place—the home of the late William Everett, the eloquent and eccentric son of Edward Everett, long a celebrated professor at Harvard and afterwards master of the Adams Academy in Quincy. Mr. H. J. Kellaway, the landscape architect, who

in conjunction with the late Frank B. Wright as architect. The results were quite in keeping with the historic dignity and residential attractiveness of the property and its environment in a typical old New England town. The “great house” was converted into an inn. In remodeling it for its new use its essential character within and without was preserved—including, of course, the fine large fireplaces with their mantels. To

meet the purposes of an inn and provide sufficient accommodations for guests a large extension was added. Seven houses of the cottage-type, designed in harmony with the central structure, were built upon the by-streets that bounded the property. These have eight rooms each, with all the conveniences, and are of a cottage type. The houses, seen in the rear from the inn, are as agreeably designed on that side as in front, with wide lawns between and no division fences. The inn is still left with grounds so spacious as to look ample, in every respect, for an old-time country-seat. The wide side-veranda faces a charming

box-bordered garden. Beyond, the historic Town Brook courses its babbling way through the property, and a rustic foot-bridge provides passage between the tavern and the cottages, permitting their tenants to avail themselves of the facilities of the inn at mealtime. The main reliance, however, is placed upon the numerous permanent guests dwelling within. The "Miller Stile Inn" is the name of the place; in the old days a feature of it was the "Miller Stile" as it was generally called in the neighborhood, used in connection with a footway across the grounds travelled by people who lived beyond.



LIVING ROOM IN ONE OF THE COTTAGES—MILLER STILE INN, QUINCY, MASS.



# *A Sculptor's Experiment in the Decoration of Concrete Surfaces*



By



*Antoinette Perrett*

THIS is a small garden with decorated concrete walls that Charles Cary Rumsey is making beside an old barn used as his studio, on his estate in the Wheatley Hills, Long Island. It is on the edge of some sloping fields, and across a little lane from it are his hunters and polo ponies. And the longer one inspects this garden, the more appropriate this proximity seems to be, for the polychrome sculpture in relief upon the walls is essentially a world of out-of-doors, of large swift-moving animals, of exhilarating movement and vigorous rhythm.

The garden is not finished. It is to have an oblong swimming pool and some furniture from designs by Mr. Rumsey, but it will have no flowers and no vines. The planting is to be just a border of ground-covered, low green things: pachysandra and myrtle, and the tiny-leaved pachystima, with dark green ferns, like the Christmas and the single-leaved hart's-tongue. In the corners there may be some low evergreen andromedas and cassandras, and at the fountains prostrate junipers and spreading yews. Indeed, it is surprising how many interesting little plants such a border immediately suggests, but the effect would be, we judge, chiefly of pachysandra. And the reason for this restraint is, of course, that it is to be a garden in which you get all your color and all your main themes from the bright reliefs along the wall. It is just a walled garden with a pool and fountains; and as you sit in it, in the shade of some old evergreens, you begin to feel as you did when you were a boy and first began to read your Homer. It is like your early dreams of adventure, with deer in

the woods and bulls stampeding on the hillside and horses careering, and with curious birds and still more curious women along the shores. At first the women seem strange, but only until one gets into the spirit of their swift sense of life and rhythm.

But, in truth, it is less a garden than it is an experiment. One can see that at a glance, in its lack of any unity of plan in the decorations. On one long side, opposite the gateway, are panels in low relief, divided by higher-reliefed women—panels of bulls and herons, horses and deer, women on the shore and under palm trees. Each is in a different color scheme; each is complete in itself; each represents a world of its own. Which makes it all the more surprising to find the varying panels combined in one long frieze on the opposite wall: women with ribboned scarfs, the long-limbed girl catching her white heron, the playful herons themselves, the women with the palm trees behind them, the bulls and horses, the deer in their twilight woods, all welded together in a single composition, in a fascinating, ingenious way. One end wall has a fountain with a low, broad relief representing women after the bath, on either side of which are groups of lounging women in smaller reliefs. The other end wall has an arched fountain with a woman in a bathing cape. On the garden side of the wall this cape is a bright terra-cotta against a blue ground, but, in repeating it on one of the outside walls, various color schemes have been tried out. This is the wall that you come upon from the hillside and that is made up of repeated arches and long, low panels. On another outer wall, the end wall, is a



VIEW OF GARDEN FROM HILL ABOVE THE STUDIO, SHOWING POSITION OF LONG FRIEZE ON INNER WALL.



THE END WALL WITH BROAD, LOW-PANELED FOUNTAIN AND SMALLER PANELS.





Photographs by Antoinette Perrett.

THE LONG FRIEZE, IN WHICH ALL THE PANELS OF THE WALL OPPOSITE HAVE BEEN ASSEMBLED INTO ONE COMPOSITION. THE COLOR IS SOFT GREEN EARTH, BLUE WATER AND PALE PINK SKY, WITH PRUNECOLORED TREES AND FIGURES IN BLACK, WHITE AND SAND COLOR (HALF-TONE FROM TWO PHOTOGRAPHS).



DARK GREY AND WHITE BULLS AGAINST A SOFT GREY GREEN HILL, WITH A FAINT PINKISH SKY. NOTE THE PLAY OF LIGHT UPON THIS PANEL AS WELL AS THE "CONCRETE" HANDLING OF THE SURFACE.





DARK GREY AND SAND-COLORED HORSES, CEMENT GREY EARTH AND A FAINT PINK SKY, WITH FIGURES OF WOMEN IN HIGHER RELIEF.



ROUND-ARCHED FOUNTAIN AGAINST THE STUDIO. FIGURE HAS A TERRA-COTTA CAPE AGAINST A DEEP BLUE BACKGROUND. PHOTOGRAPH REVEALS SOMETHING OF THE CHARM OF SUN-LIGHT AND SHADOWS UPON THE CONCRETE SURFACE.



THE HERONS ARE BLACK AND WHITE,  
WITH A PRUNE-COLORED TREE, GOLD  
EARTH, BLUE SEA AND TERRA-COTTA SKY.



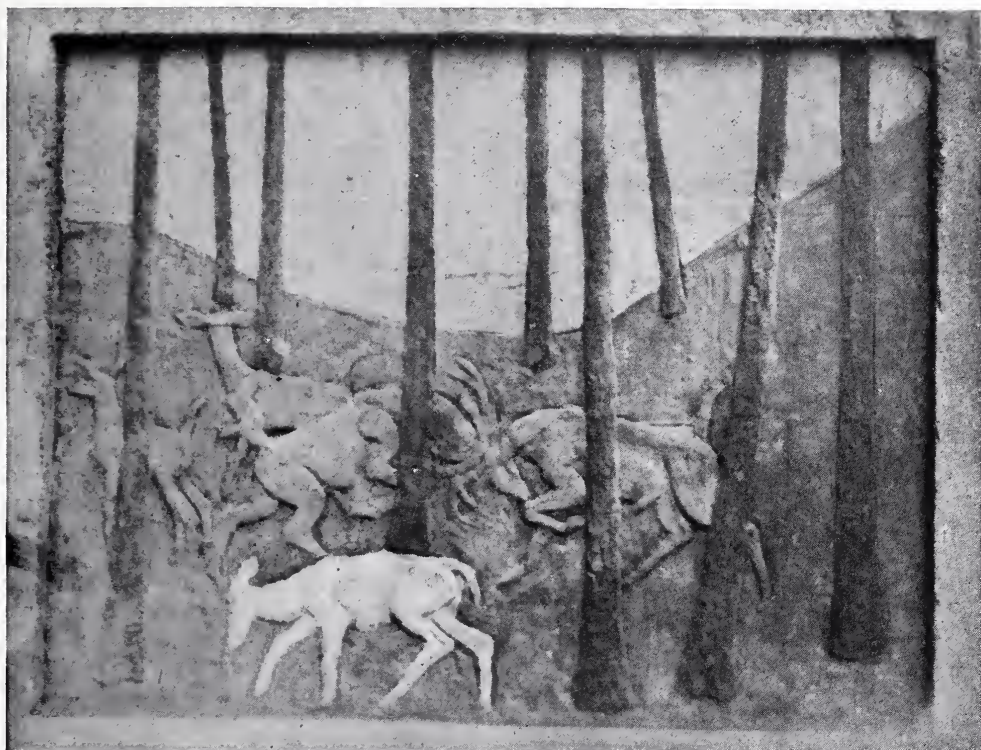

THE DEER ARE WHITE AND SAND-COLORED, WITH A SOFT GREEN HILL AND A FAINT PINKISH SKY.

horse-trough with an arched panel and with small medallions of hunters and animals inserted on either side. It all has a spontaneity, a sense of playfulness, that marks it as a sketch rather than as a finished work. Yet this quality does not blind one to the essential genius of the work. It is important as sculpture.

However, the garden is not an experiment in sculpture, but in the use of form and color in the decoration of concrete surfaces; and it is for trying out various treatments that Mr. Rumsey has really put up these garden walls. The decoration of concrete is a revived problem. Here is this age-old material that has come back into our life like some old Leviathan, a crude, shapeless mass that we must mold to our purposes, into the character of our life. The old carved details, the quarter-rounds and ogees, the egg-and-dart and all our classic heritage of stone details are both inherently and economically out of place in its use; and, in addition, such details do not particularly express modern feelings. The life of our time is full of swift movement. It is a kaleidoscope of color. And Mr. Rumsey's is one of the ways out. In the use of richly or softly colored reliefs and of brilliant or monotonous friezes on the flat surface of concrete, we have a means of decoration that is at once inherent in the material and expressive of modern life.

It is an economical means of decoration—putting colored concrete into molds. But there we come upon the first problem from a sculptor's point of view, for the relief must be simple and broad, and must take well to the roughening of its outlines through the sandy nature of the concrete. Indeed, if the decoration

is good, one of its very charms will come from this softening and blurring by the material itself. Perhaps that accounts for the pictorial quality of the photographs of the reliefs, a blurring and softening that seems to cause a quickening of one's imagination.

In mixing the color with the concrete, Mr. Rumsey has obtained the effects he sought, and it now remains to be seen what influence the weather will have upon them. One panel has been out in the open for five years and has borne the exposure absolutely well, which is a good augury.

As for the colors, there are white and black, putty color and sand color, a soft grey and a soft grey green, a light and deep wash blue, a gold color, a terracotta, a particularly subtle prune color, which is often used for the tree trunks, and a washed-out pink, a charming shade, that is sometimes used for earth and sometimes for the sky.

The colors are varied enough to offer the greatest possibilities, from soft-toned reliefs in sand and putty and soft greens and pale pink to ladies with terracotta capes against deep wash-blue walls, or herons on prune-colored branches with a gold earth, a blue sea and a terracotta sky behind them. The experimental nature of the work is apparent in the way the color has been used in a separate and complete scheme in each panel regardless of the harmony of the whole. It is only when we come to the long frieze that we find them all combined into one continuous and harmonious whole. The colors are handled simply, as in a poster, in flat decorative fashion; and the panels reflect the spontaneous joy which the sculptor felt in working out a new technique.



# English Architectural Decoration

## *Text and Measured Drawings* by Albert E. Bullock

### Part XV-2. The Adam Period (Continued).

FROM the plan of Sion House, given in our last issue, it will be gathered that Robert Adam was imbued with the Eastern spirit of palatial grandeur, to which he directed the attention of his younger brother James.

With every new commission he endeavored to introduce the curvilinear treatment of columnar architecture, his ceilings invariably forming some combination of the dome segment with the quasi-barrel vault of coved formation above the main cornice.

In detail the chief motifs were obviously culled from ancient supulchral monuments, as has already been observed; while the principle of geometrical subdivisions to the ceilings with their ornament and plaques or bas-reliefs was followed closely by admirers and imitators of the style as with common consent.

In chimneypieces we find some permanent value, since this feature is of the nature of a movable fitment of marble or wood, usually of considerable interest and skill of execution.

In color the decorations varied considerably to ceilings—a ground of pale apple green was occasionally adopted; chimneypieces of wood were often gilt upon an azure or pale French blue ground; figures of the caryatid type exist in black and gold, and wooden candelabra occur in green and gold.

Since the school sought to design the correct setting and the furniture appropriate to each apartment, it follows that a definite color scheme must have been chosen in each instance, because harmony of environment and detail was the soul of the style of the Brothers Adam.

The form of application of the ornament and the nature of its composition rendered it capable of addition to an existing room, without recourse to drastic

reconstruction. This appealed to a large majority of clients who required an inexpensive and ready method of obtaining an effect, without excessive trouble and expense in panelling the apartment afresh. The mediums used, in addition to the carving of ornament in wood, included pewter and carton pierre, the latter probably being adopted as an economic method of exhibiting fine ornament, although less permanent than wood or marble, but of much reliability to the true representation of the subject.

From the account James Adam gives of his tour in Italy it would seem that he was a daring critic of the works of Palladio. Conceit was apparently an ill concealed quality in these days almost amounting to a virtue.

The Villa Rotunda at Vicenza (upon which the Earl of Burlington is said to have based the design for his residence at Chiswick) is accorded some mead of praise by James Adam, who was certainly very observant, defining with care the differences in the proportions of various buildings. At Pompeii he "saw a room which seemed to have been painted with arabesques, and had a very pretty mosaic pavement with a Medusa's head in the centre."

His notes indicate an extensive survey of ancient villas in the vicinity of Paesilippo, Salerno, Paestum and other places in the district of Naples, including an excursion to the sepulchre of Agrippina near Pozzuoli.

Early in 1763 James Adam returned to England to assist his brother Robert in his practice, when the latter was busily engaged upon the additions to Sion House, Isleworth. The vestibule of this mansion is as stately an apartment as one would wish to find. The dark grey marble columns with Greek Ionic gilt

capitals supporting a decorative entablature of good design and having figures over the orders, with the usual mahogany veneered doors, gives a very striking effect. The detail of the marble chimney-piece is equally effective, exhibiting a mastery of detail which at the time of its original inception was unique.

In designing furniture, in keeping with his style, Robert Adam followed the system of William Kent, who in his day was as great an exponent of the canons of good taste in decorations, furniture and dress, even if his particular code was somewhat coarser than the Adam manner.

The chief buildings in London with which the brothers were associated, apart from Adelphi Terrace, include Stratford House (now Derby House); Ken Wood, Hampstead; Lansdowne House, and No. 20 St. James's Square as completed houses, with additions to many other existing houses; also Nostell Priory and Harewood House, both in Yorkshire; Luton Hoo for the Earl of Bute and additions to Osterley House, Isleworth, the seat of the Earls of Jersey, built in the reign of Queen Elizabeth by Sir Thomas Gresham.

The earlier portions of Kedleston and Croome Court, Worcestershire, contain some typical examples of furniture and decoration, testifying to the keen application of their cult in every detail.

Kedleston was built early in the eighteenth century by one Smith (probably William Smith of Warwick) for one of the ancestors of the present Lord Scarsdale. The Adam additions consisted chiefly of the rooms on the north front.

Croome Court was a perennial source of income from the time when Robert Adam designed the first pavilion in the grounds in 1759. The original house appears to have been erected by Launcelot Brown of landscape garden fame, and is illustrated in the fifth volume of "Vitruvius Britannicus."

The banqueting hall of this residence of the Earl of Coventry was decorated by Robert Adam in a style closely resembling several features of the long gallery at Sion House, but without pilas-

ters. The marble mantel consists of two boldly carved caryatid figures as supporters on either side of the architrave holding a floral festoon forming the frieze, above which is an enriched overmantel with a classic subject architecturally treated. On either side are three niches containing statues.

The ceiling is composed of a series of large molded hexagonal coffers in juxtaposition. The room is sixty-two feet long and the original design (dated 1763) is preserved in the library at Croome Court. Equal care was taken with portable objects and fittings, for which many signed designs are extant.

The dining room at Lansdowne House is not dissimilar to the banqueting hall of Croome Court—one end, however, having an alcove with columnar treatment. The rear drawing room is a more elaborate apartment with arabesqued pilasters, having on one side a large recess with semicircular arch over, containing a hand painted lunette. The ceiling contains several painted panels, accompanied by the usual winged griffins, acanthus scrolls and other typical and familiar motifs associated with the style. The doors are mahogany veneered and enriched with ornament very similar to the example given from the Victoria and Albert Museum. The ball room is a later introduction of a more classical nature, having little ornament and concave ceiling with square coffers, anticipating the work of Sir John Soane at the Bank of England.

How different is the ceiling of the gallery at Harewood House, Yorkshire, wherein all the richness of Adam invention appears to center. This house with its furniture is among the most beautiful of the many instances of the brothers' inventions. The jewelled character of their work is most noticeable in the decorations of this famous residence and in the remarkably delicate inlays ornamenting the writing tables, commodes, etc., which adorn the several rooms.

Luton Hoo has been somewhat altered of late years, but the original plan remains with the circular entrance hall having square courts on either side, the salon occupying the center of the





CARVED MARBLE MANTEL DESIGNED BY  
ROBERT ADAM FOR THE TWELFTH MARQUIS  
OF WINCHESTER, ABOUT 1780. ORIGINAL  
DESIGN IN THE SOANE MUSEUM, LONDON.



CARVED WOOD MANTEL, ADAM PERIOD, PROBABLY FROM DESIGNS BY PERGOLESÌ; FIVE FEET SIX INCHES HIGH, WITH EIGHT-FOOT SHELF.



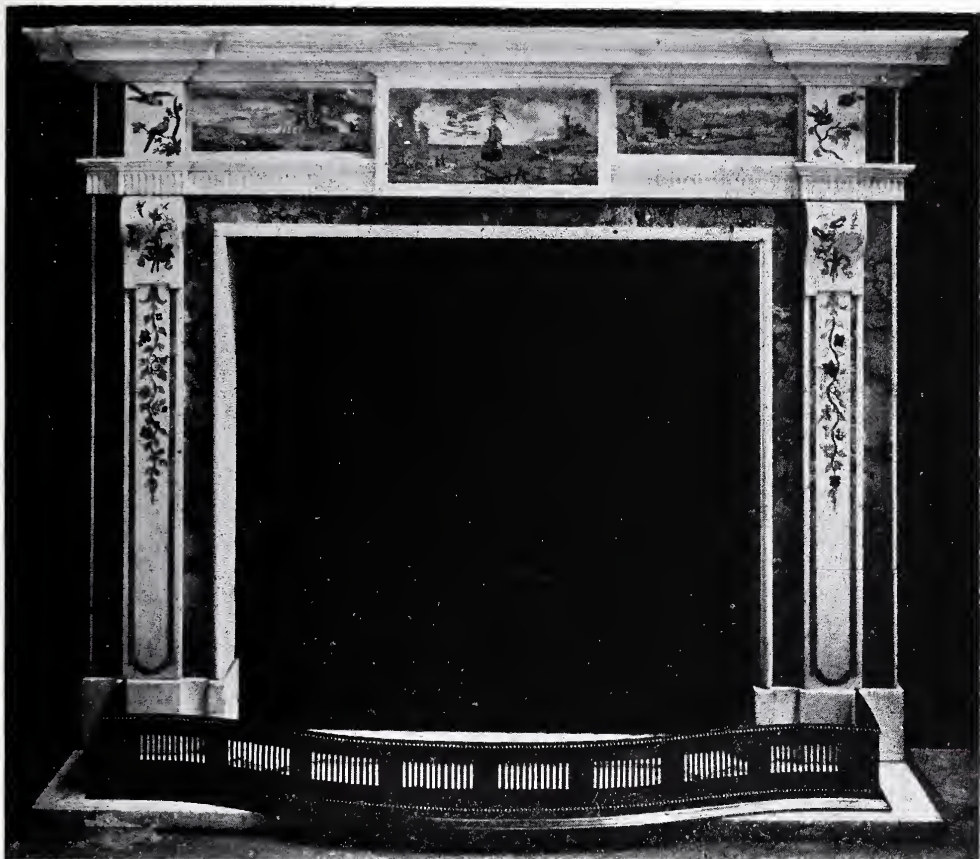

INLAID MARBLE MANTEL FROM RATHFARNHAM CASTLE, IRELAND, 1780, BY PETER BOSSI.



DETAIL OF OVERMANTEL IN DINING ROOM,  
ABCHURCH LANE, LONDON, E. C., ABOUT 1785.



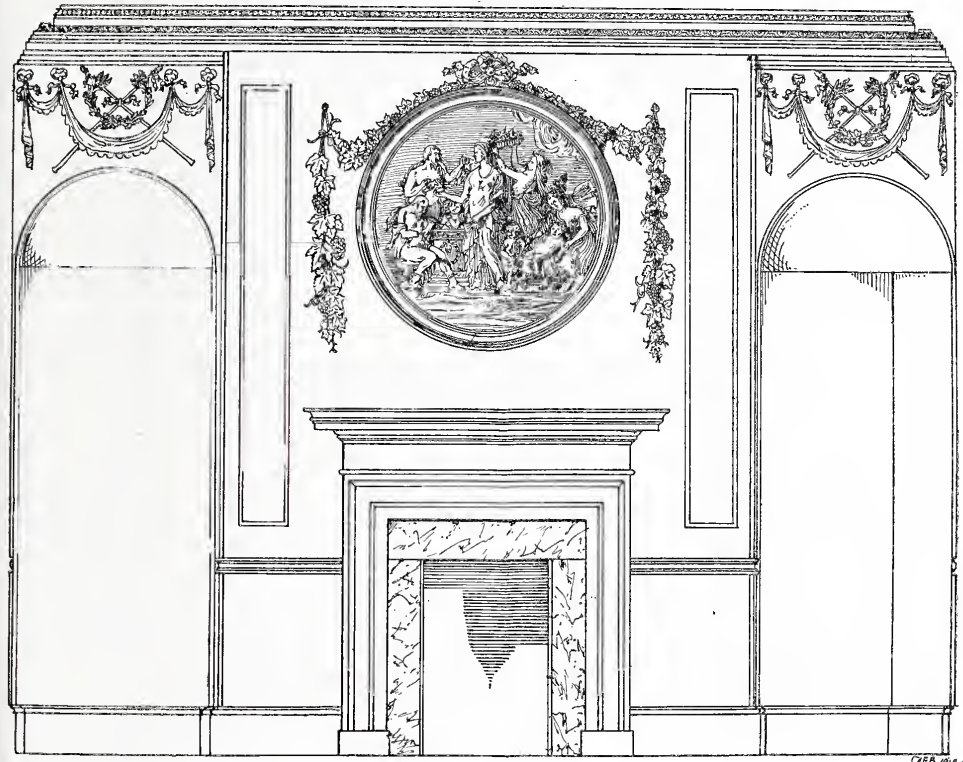
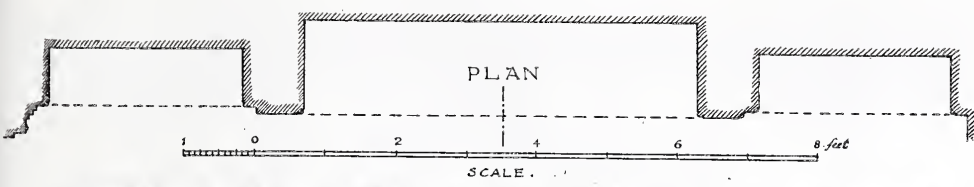

CHIMNEY PIECE SIDE.

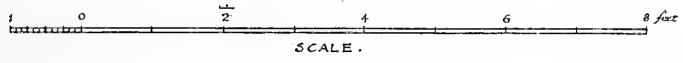

CHIMNEYPIECE SIDE IN ADAM PERIOD  
ROOM FROM ABCHURCH LANE, LONDON.

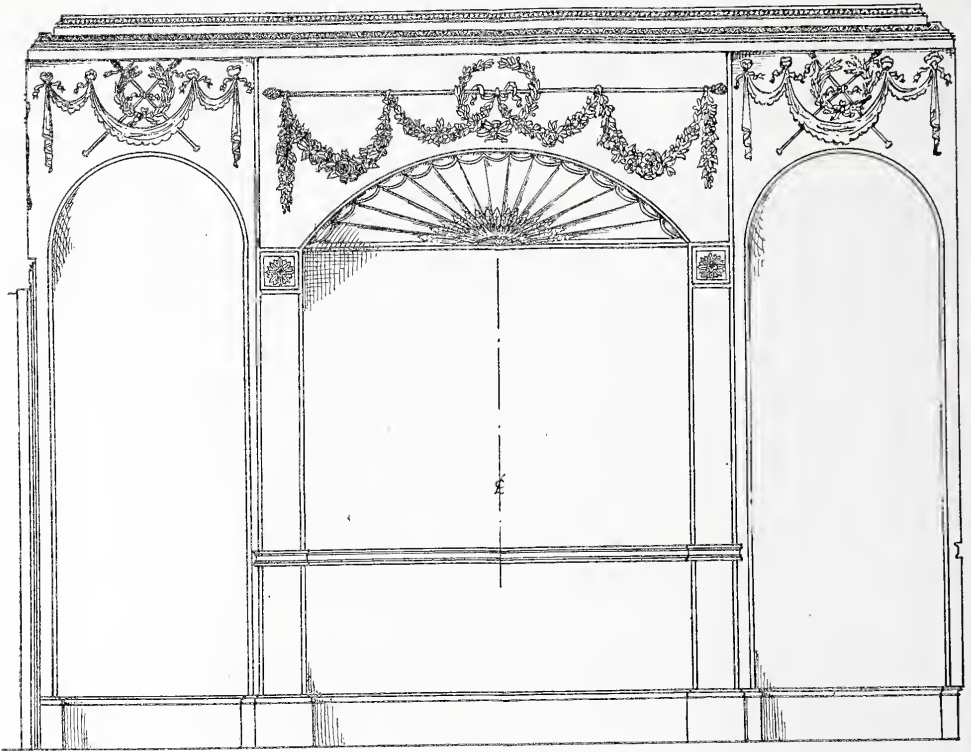

SIDE WITH ALCOVE.

SIDE WITH ALCOVE IN ADAM PERIOD  
ROOM FROM ABCHURCH LANE, LONDON.



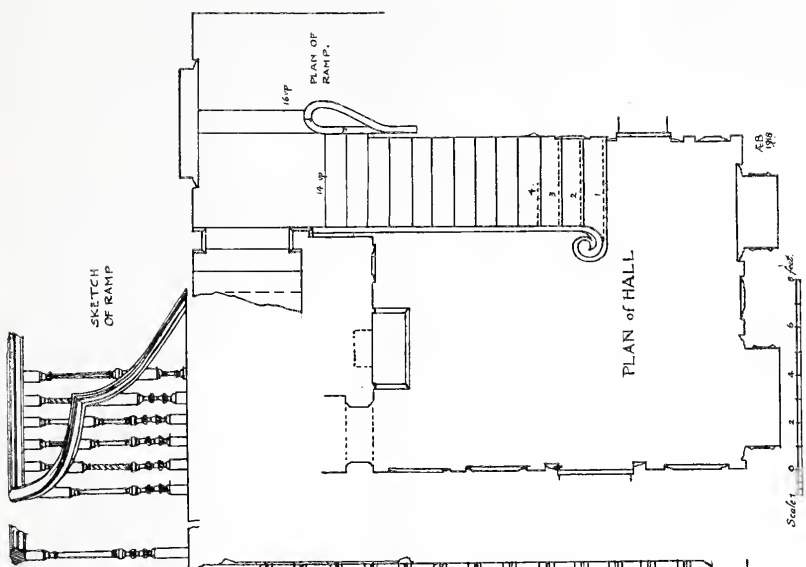
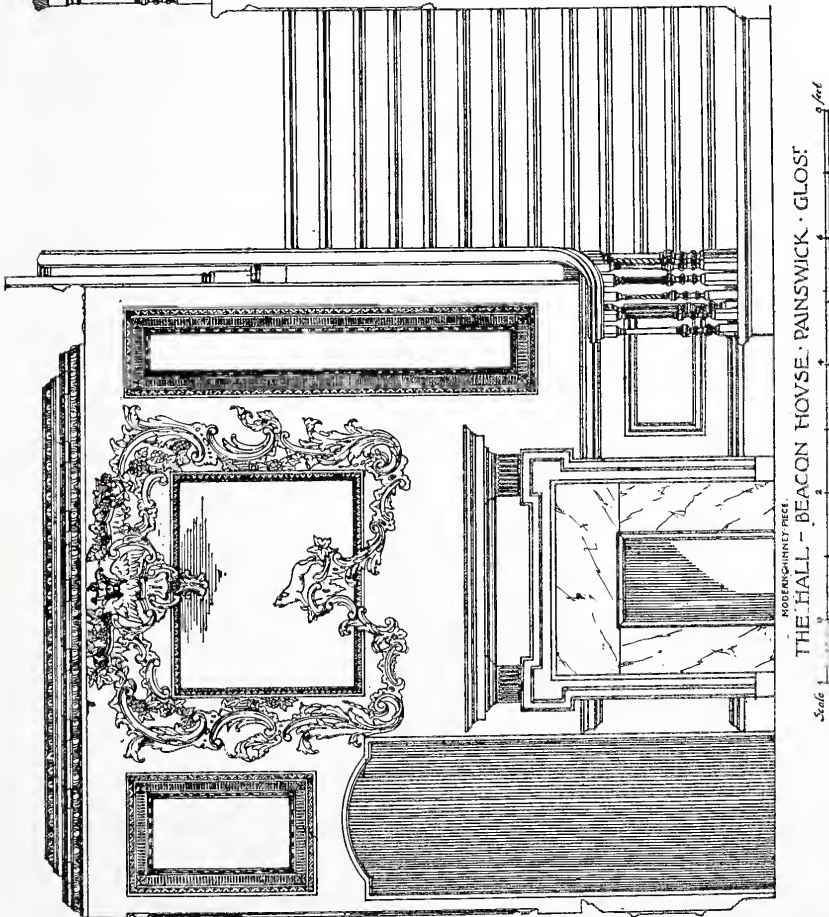

MAHOGANY \* GILT  $\frac{1}{4}$ " EBONY =  $\frac{1}{4}$ " \* GILT MAHOGANY

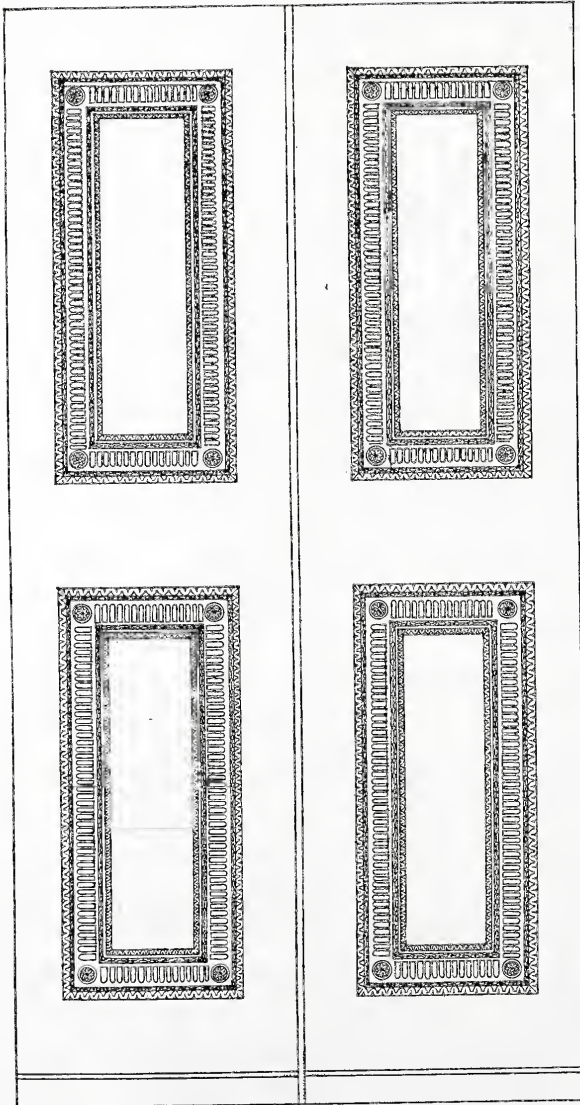
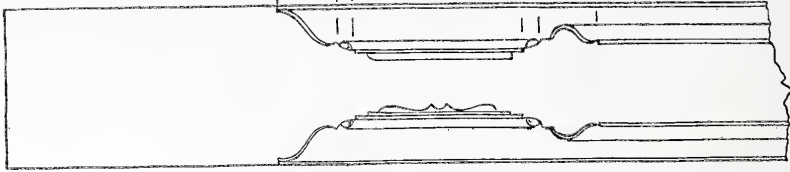

ADAM PERIOD .  
VENEERED DOOR  
GIVEN BY COL :  
H. MYLLINER TO  
V & A MUSEUM .





*Doors for the Countess of Derby  
Designed by Robert Adam, 1774*

*3<sup>d</sup> Drawing Room*

*Parlour Door*

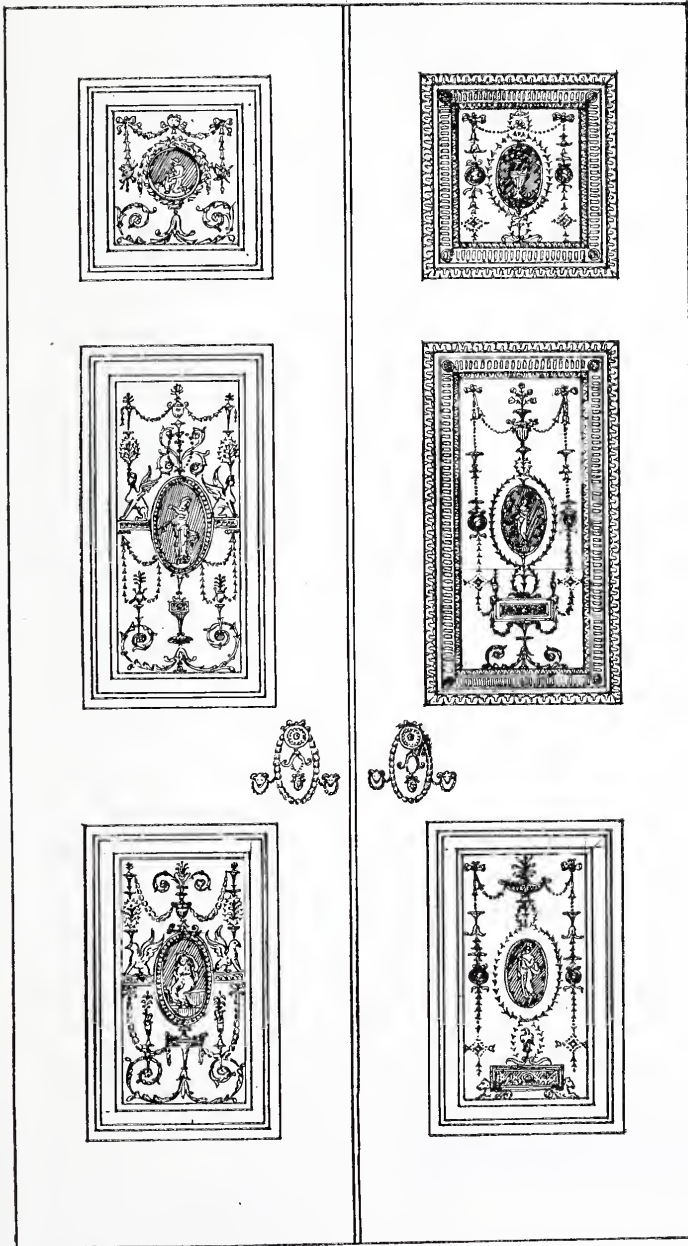

*SCALE FOR DOOR*

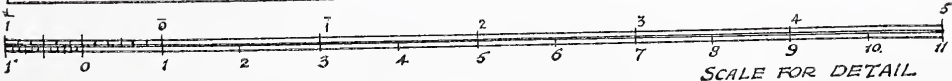

*SCALE FOR DETAIL*

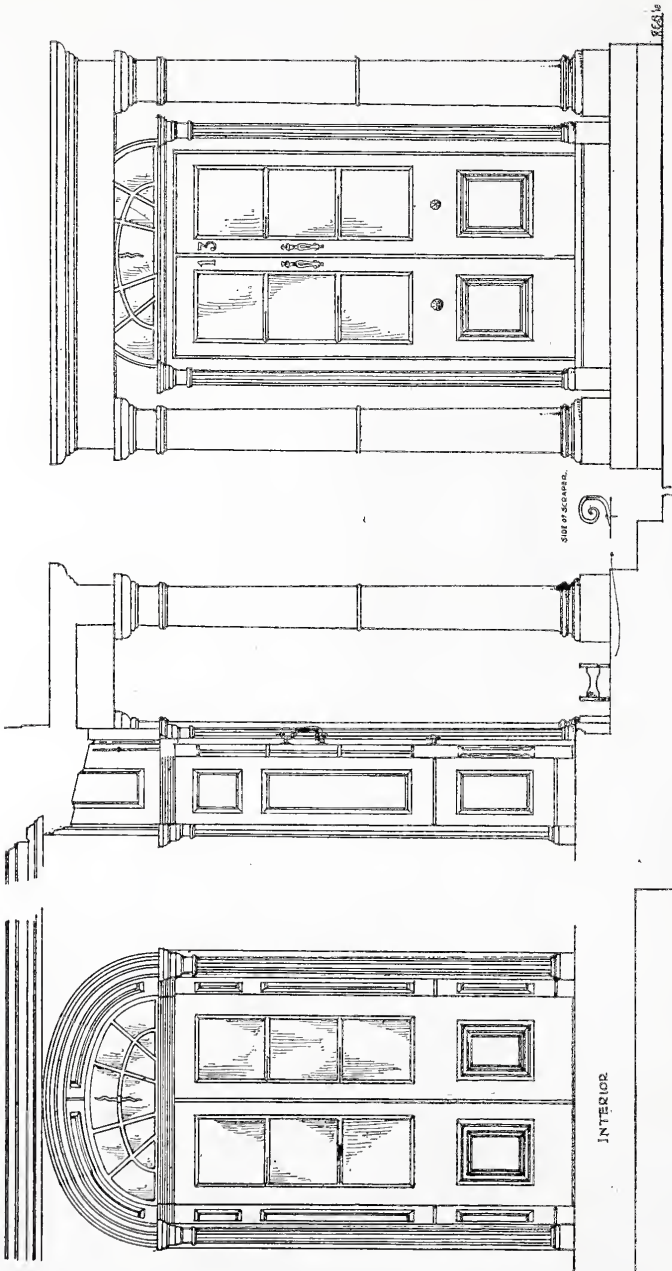

EXTERIOR.

SECTION.

INTERIOR

DETAIL OF LATE GEORGIAN DOORWAY.  
 FROM NO 13 HAMMERSMITH TERRACE.  
 LONDON . W.

SCALE 1/2" = 1' 0"

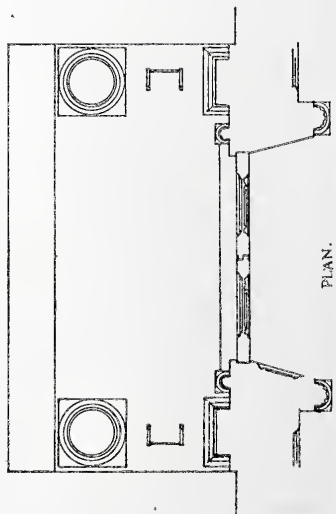

PLAN.



south front. A small circular powdering room adjoins the northern end of the library, and Lord Bute's dressing room is placed to the western end of the salon.

The gardens are modern, being very charmingly arranged for the present owner, Lady Wernher, by Mr. Romaine-Walker, with many artistic variations in parterres and garden architecture.

The Brothers Adam, as has been previously observed, excelled in planning irrespective of the size of the house. No. 26 Grosvenor Square was based upon French principles, being designed in 1773 for the Earl of Derby. The house is now pulled down, but contained several very interesting features, not the least among them being the room known as the third drawing room, situated to the right of the hall, which is shown with an enriched vaulted ceiling in the "Works of Robert and James Adam."

No. 20 St. James's Square was planned for Sir Watkin Williams Wynn on similar lines, with the rooms intercommunicating and having the stables situated at the rear. With these terrace houses Robert Adam usually made a feature of the internal court, treating the blank wall of the adjoining house upon some sound architectural principle by way of interest and decoration.

It is refreshing to note the ingenious methods adopted to circumvent the pitfalls with which terrace house planning is beset, namely, the situation of the main staircase, the internal lighting and many other things which hamper the design and confine one's ideas within definite limitations.

The illustrations given indicate the types practised during this era. The Chippendale type of overmantel from the house at Painswick shows adjoining panels of distinct Adam feeling; while the room from the demolished house in Abchurch Lane is interesting as a complete theme of an original type, having recess for sideboard and niches for smaller pieces of furniture on either side.

Porches varied in character. The example from No. 13 Hammersmith Ter-

race is a late Georgian one where reeded columns are used. Fanlights have already been illustrated from London and the Provinces. Many delicate designs were executed in metal, as is instanced by the example now in the Victoria and Albert Museum, formerly at Harewood House, London.

Contemporaries of the brothers practised in close conformity to their principles, often making the identity of authorship difficult to discern. There are, however, certain variations which become familiar to the connoisseur. For this reason two chimneypieces are here given for comparison of detail: one a finely carved wood mantel, an obvious Pergolesi, closely resembling his published design of 1770, illustrated on page 32 of Charles's "Compiler"; and the other a genuine Adam example, executed in marble for the twelfth Marquis of Winchester, about the same date, for which the original design exists in the Soane Museum Collection.

The work of W. Thomas, W. and H. Pain Bretingham, Sir Wm. Chambers, Servandoni, Sanderson and others was an attempted plagiarism without the subtle genius of the authors who brought a note of variety into each fresh scheme.

The brothers went to considerable pains to design door furniture in order that the handle and key hole should be combined in one ornament both for use and utility. A type of this feature is shown in the doors designed for the Etruscan room for the Countess of Derby, and many another example exists with festoons of husk or bead enrichment in ormolu or lacquered brass.

Water gilt work, as practised in France for clock mounting, was gradually adopted in England as a healthy rivalry to the continental custom.

Time and space would fail in any attempt to exhaust the many activities of this school of design or even of the works of the founders, but an effort will be made in our next issue to further the subject by reference to its general influence upon contemporary and subsequent decorations.

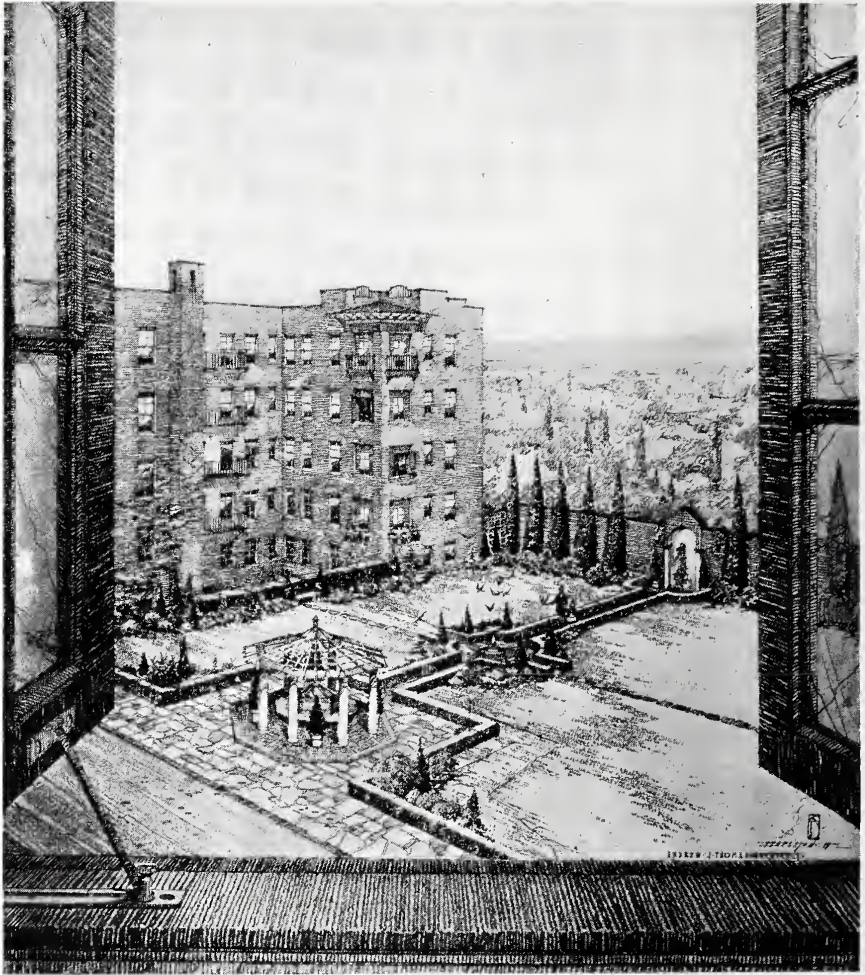

GARDEN APARTMENTS FOR CITY AND SUBURBAN  
HOMES COMPANY, ON SEVENTEENTH AVENUE,  
BROOKLYN. ANDREW. J. THOMAS, ARCHITECT.



# Garden Apartments in Cities



By John Taylor Boyd, Jr.

A RATIONAL system of housing is essential to the welfare of a great city. It is even more necessary there than in small communities, for in cities life grows always more complex under the pressure of modern business, and the increasing strain places citizens under greater and greater tension.

The need of more reasonable types of city housing is now well recognized. There are even some far-sighted observers who believe that good housing of itself will not suffice—that besides good housing, the city should be so planned as a whole that its economic organization can function most effectively. In the minds of such, city planning is essential to housing.

It will, therefore, be welcome news to those who seek progress in housing that recent achievements in the field have gone far toward establishing a worthy standard both for city planning and for city housing. Architects and housing experts in New York City have shown that such housing is not only possible as a matter of design, but—even more important—that it may profit the landlord more than the existing undesirable types. This, indeed, is a great step forward, for whether one likes it or not, when once good housing is proved to be sound business it will be pushed further on that basis than if it were founded solely on a programme of artistic or civic betterment.

The creation of this improved type hinges on the discovery that, in design, the city block is the true unit of planning, and not the lot. This new principle of itself would cause revision of older conceptions of housing. It gives an entirely new basis to apartment house planning, and, since it makes the block

the unit, it also renders more significant the relation of city planning to housing. In fact, the full import of this and other newer principles is not yet perceived. But that they will cause housing planning to advance far beyond previous experience seems likely.

In order to understand clearly what the new principles reveal, one may refer briefly to the standards which have been developed in small community housing, and then trace the corresponding development in city housing. This will help one to realize the difference in the two types, and also to perceive the unsatisfactory progress of the city type in comparison with the other.

Small town housing follows mainly the old individualistic American ideal of "own your own home," as it has recently been popularized; that is, the ideal of each family in sole and complete title of land and isolated house upon it. In practice, of course, this ideal of isolated ownership is not always carried out. Nevertheless, it may be said that, notwithstanding compromises in the form of tenantry, or of multiple types of design, such as semi-detached or even group or flat housing, the acknowledged ideal is individual ownership.

This ideal of individual ownership of small neighborhood housing has taken the form of standards which are themselves nearly ideal. In making this statement I do not intend to deny the obvious fact that such standards are not yet widely followed, and that they are rather models for future progress. Still they exist, and each year their influence is growing stronger. If the technical variations of these models be not considered, in the main they comprise the following essentials:

- (1) A type of house unit which in

plan, is almost perfect for practical, efficient and comfortable operation; which, in its sanitary and mechanical features, reaches a higher standard than elsewhere; and which, on the artistic side, in a few of its best models, compares favorably with any existing house architecture. Moreover, since the American small house at its best provides more space and is designed for a far higher standard of living than any other type in the world, it is not exaggerating to say that no other nation has a standard that equals it.

(2) The individual units have been effectively and beautifully combined into well coordinated group and community plans, which are successful both from an economic and an artistic viewpoint.

Could our ideal of small neighborhood housing be carried much further? Is it not reasonable to say that the tradition for American town and village housing

is now determined, even though it is not yet established in many districts?

If now we turn from this splendid achievement in small community housing, in the city we meet a different situation. Here the bulk of the population is unsatisfactorily housed, in regard to individual housing units and grouping of the units. And as for any relation to a community plan, that is hardly thought of in city housing.

Nevertheless, in spite of the backward conditions, on which most observers agree, there has been a steady, even if very slow, progress over a period of years. The beginnings of this improvement reach back into history; but for us the real beginning came in New York City, when a group of housing experts under the leadership of Mr. Lawrence Veiller procured the passage of the New York Tenement Act of 1901.

Thus the first steps were in the field

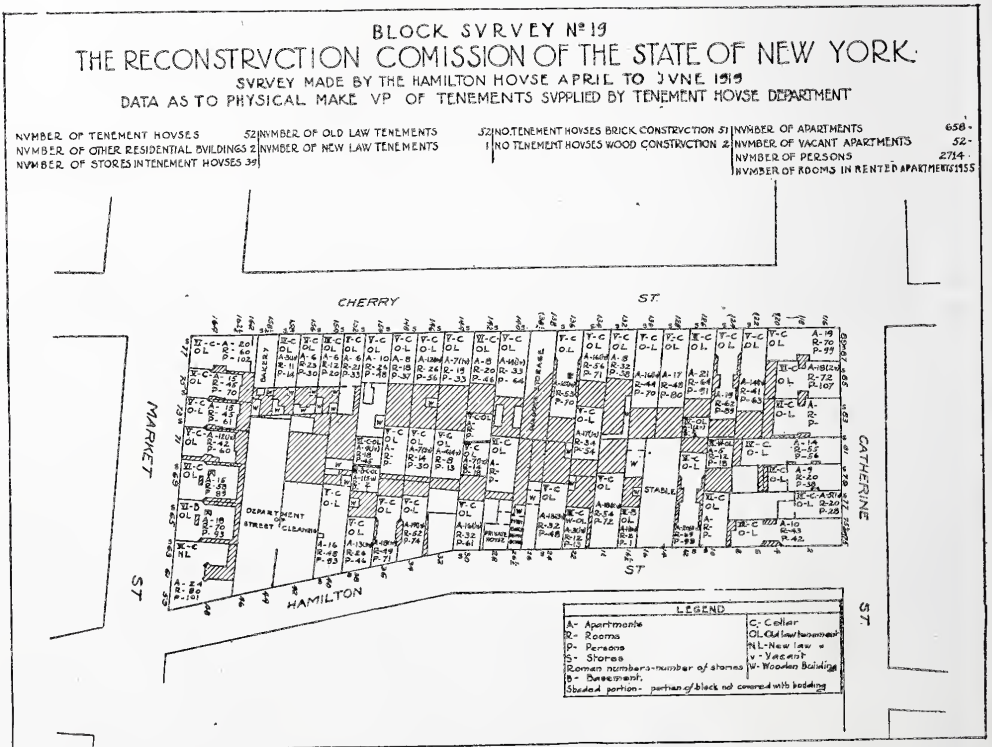
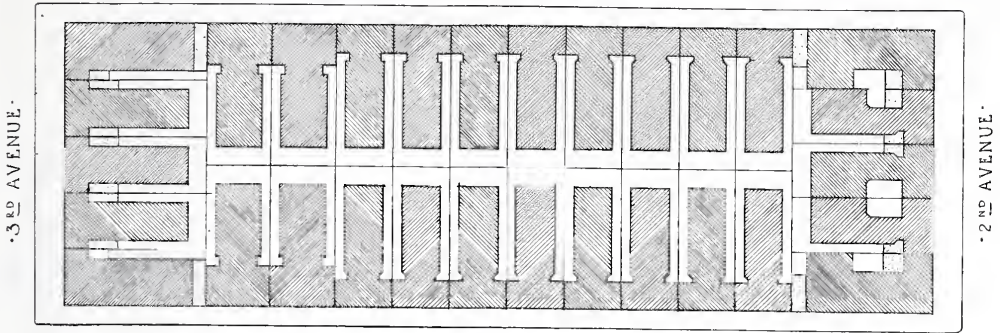

DIAGRAM A.—CHARACTERISTIC BLOCK OF TENEMENTS IN MANHATTAN BOROUGH, NEW YORK CITY, BUILT BEFORE PASSAGE OF TENEMENT HOUSE ACT OF 1901.





· 66 TH STREET ·

DIAGRAM B.—SHOWING EFFECT OF TENEMENT HOUSE ACT OF 1901 ON TENEMENTS BUILT ON SINGLE CITY LOTS.

of legislation—or as it is said, they were “restrictive. That is, improvement was not sought chiefly in improved types of buildings, or following structural conceptions, but was based on principles of sanitation and of public welfare. The aim was more to prevent bad types of housing than to invent good ones. To say this is not to belittle the Tenement Act of 1901. Unless evil, cheap types were forbidden by law, better types could hardly compete in the real estate market. Certainly the Act put a stop to bad housing practices in thorough fashion. Still, since it established a minimum standard, the inertia of builder and investor and tenant all tended to accept that minimum as the maximum, and for a long time no one cared to do better than the law required.

Such a drawback was in the mind of Mr. Veiller, the author of the Act, when he so drew its provisions as to make it unremunerative to build tenements on the twenty-five foot city lot. As a result, speculators soon found that a wider frontage was a better real estate investment, and the forty, forty-five and, of recent years, the fifty-foot lot came to be the minimum, as proved by the statistics of the Tenement House Commissioner of New York City. Besides this widening of the lot unit in buildings, the Act of 1901 was of vast benefit in prescribing really high standards of construction, sanitation, fire prevention, and of light and air and ventilation, particularly as regards sleeping rooms.

The good effect of the Tenement Act may be seen by comparing diagrams “A” and “B” and “C.” “A” is a typical New York block of typical “old law” tenements. It pictures the abominable conditions resulting from the unrestricted real estate activity of speculative builder and of landlord. In many districts of New York City, hundreds, even thousands, of people are hived together in a single city block, with three out of every four exterior walls of each tenement house giving on narrow light wells. In some cases “courts” were only eight inches wide! The typical plan of the individual tenement was a string of rooms along a 25 by 100-foot lot—known as the “railroad” or the “dumbbell” type—in which the interior rooms depended on other rooms for any light and air. Diagram “C” shows a “railroad plan” and a “dumbbell” plan. When it is realized that the sanitation of such hives was as rudimentary as was their planning, one gains some idea of the degraded architecture of these dwellings.

Diagram “B” is that of a block of tenements built under the Act of 1901. The betterment is striking. Although the area built upon is 70 per cent, the courts introduced between each two dwellings provide at least a decent amount of light and air in all rooms. Besides, as noted, numerous other provisions of the law enforce sanitation, a reasonable amount of cubic air space in bedrooms, and other ameliorations.

These diagrams bring out vividly the

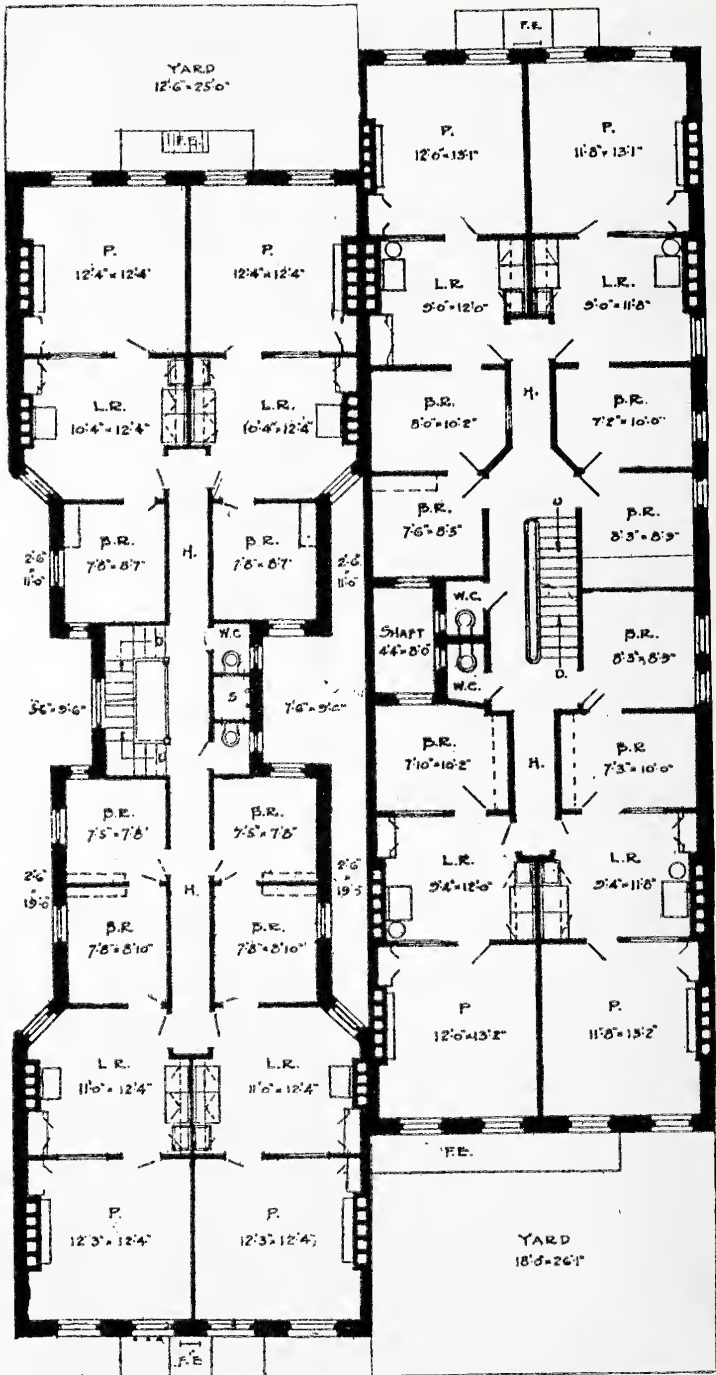

"Dumbbell" Type

"Railroad" Type

DIAGRAM C.—TYPICAL OLD-LAW TENEMENTS IN NEW YORK CITY.



ALLEY

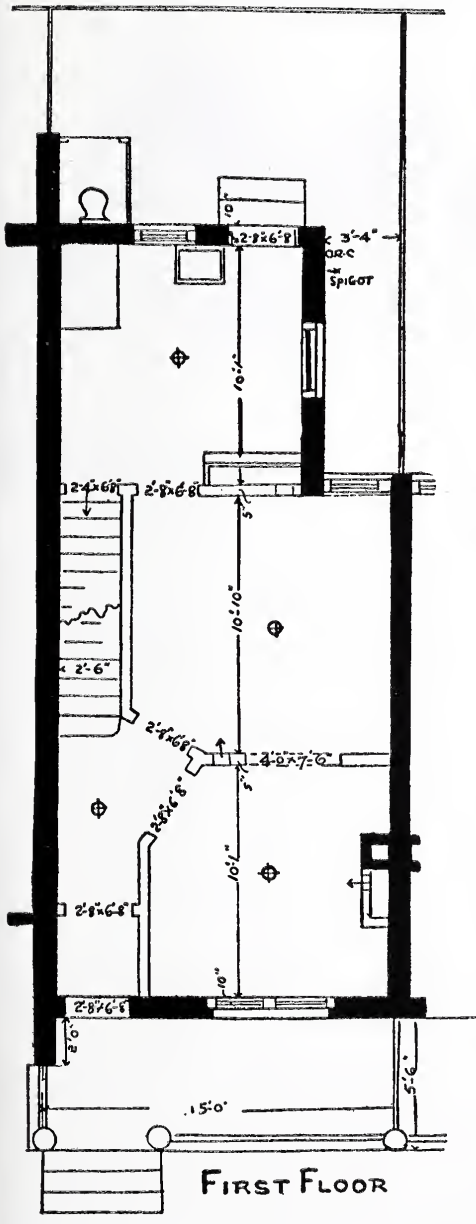

FIRST FLOOR

ALLEY

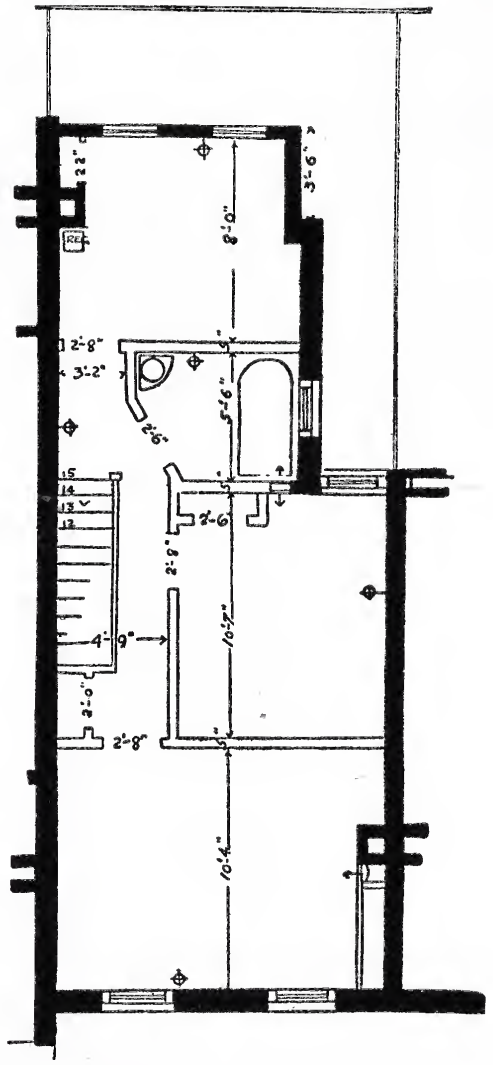

SECOND FLOOR

DIAGRAM D.—PHILADELPHIA ROW TYPE. REPRODUCED, BY PERMISSION, FROM HELEN M. PARRISH'S PAMPHLET, "ONE MILLION PEOPLE IN SMALL HOUSES." NATIONAL HOUSING ASSOCIATION, PUBLISHER.

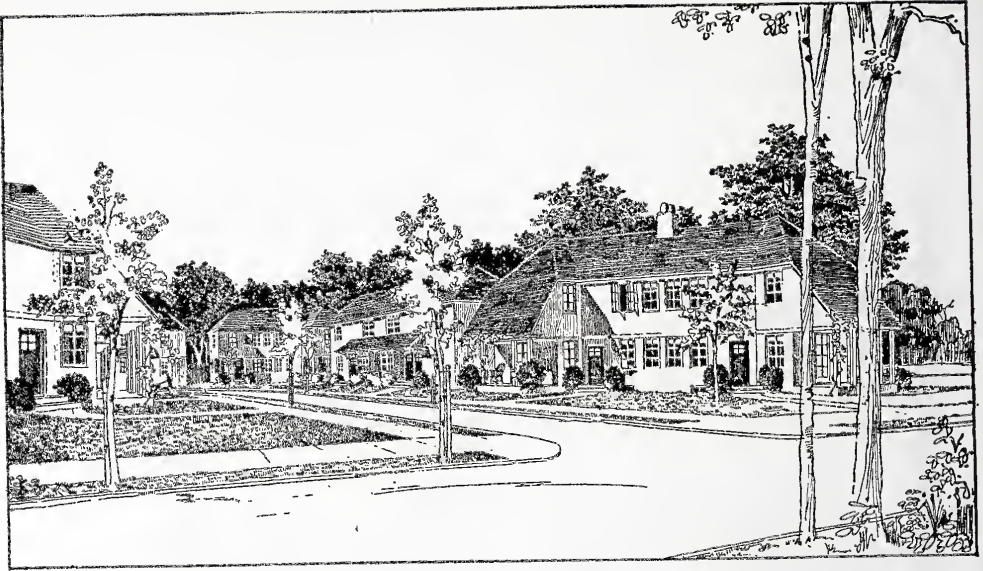

ENTRANCE FROM FAY AVENUE, TO HOUSING DEVELOPMENT AT ELIZABETH, N. J.  
Murphy & Dana, Architects.

remarkable improvement in conditions of city housing in New York that was caused by the Tenement Housing Act of 1901. One should always remember that the act was based mainly on principles of sanitation and of public welfare, and that it pushed housing progress probably as far as it possibly could on that basis. Only recently has progress been shifted into another path—a more positive one—and is now seeking a constructive development of housing which, in addition to being healthful and more decent, embodies structural ideas of well planned buildings.

For years this search for more efficient design in multiform city housing has been continued. In New York, as described, the Tenement Act of 1901 stimulated it, since it forbade the worst types of housing and thereby encouraged the development of improved types. Elsewhere, in other cities, public spirited citizens and semi-philanthropic corporations—corporations with dividends limited to about four per cent—devoted years of the most enlightened experiment to the same end. As a result, General Sternberg, a retired Surgeon General of the Army, in Washington, and the Octavia Hill Association, in Philadelphia, developed im-

proved types of the well known "row" or "block" housing characteristic of those cities, which are also found in outlying districts of New York. These types in their way attained the same standards of sanitation and decency as the new law tenements of New York City, and were superior in that fewer people were concentrated on an acre of ground. In fact, at its worst, this row housing was never so bad as the New York slums, since the houses were usually two storied, and inside rooms—rooms without windows on open air—were not so numerous. Still lately, further attempts on the side of better design were made by dividing the rows into groups, thus allowing entrance at intervals to the interior of the blocks, and also eliminating the unfortunate service alley that often ran through the center of the block. One of the best examples of this amelioration is the housing at Elizabeth, N. J., by Murphy & Dana, architects, illustrated in the *Architectural Record* for July, 1918, a plan of which is reproduced in diagram "E." Diagram "D" shows "Philadelphia" row housing in improved form. Diagram "F" shows typical New York tenements of several years ago built under the new law.



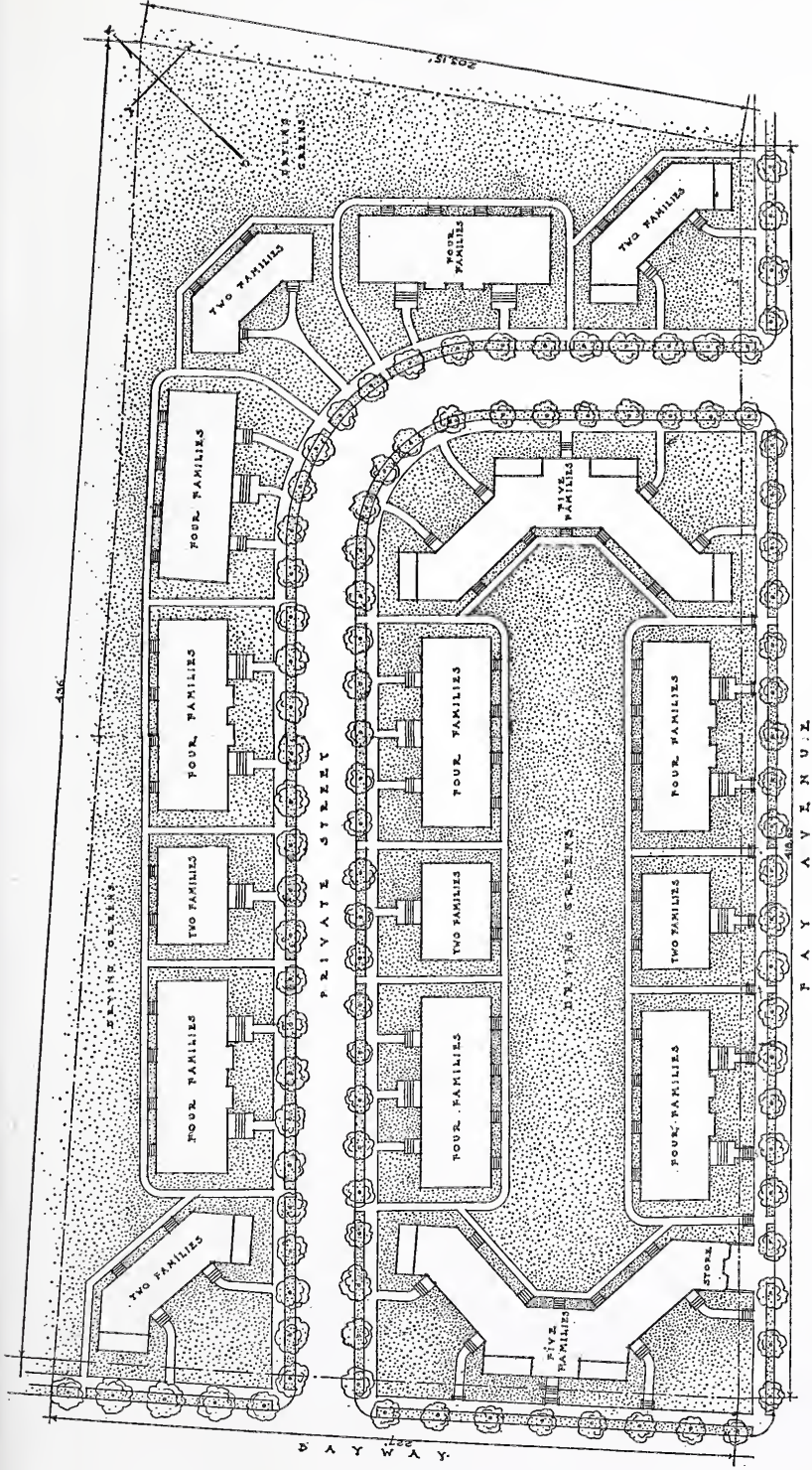

BLOCK PLAN.  
 HOUSING DEVELOPMENT AT ELIZABETH, N. J.  
 FOR ARCHIBALD H. BULL, ESQ.  
 MURPHY & DANA, ARCHITECTS  
 351 MADISON AVE., NEW YORK

DIAGRAM E.—FOR FULL DESCRIPTION OF THIS DEVELOPMENT SEE ARTICLE BY MR. LAWRENCE VEILLER IN ARCHITECTURAL RECORD FOR JULY, 1918.

1/8" = 10'  
 SCALE OF FEET

It is clear from a comparison of these types of housing that the problem is at its worst in New York City. There land values are highest, congestion is greatest, and, what is worse, habits and customs of living in over-crowded areas are firmly established. If in New York a satisfactory solution is possible, progress elsewhere is certain.

Among the first steps in developing improved types in New York were the tenements erected by the City and Suburban Homes Company, an organization which has earned a name for itself in the history of American housing since its foundation in 1896.

The record of this company is extraordinary on all sides of housing. It provides wage earners with superior housing and service at rentals that compete with speculators. If its dividends are limited to 5 per cent—formerly 4 per cent—it has always paid dividends; and in addition, by introducing modern accounting into New York real estate, it has charged off full depreciation and obsolescence on its books, besides doing what speculators rarely ever did—kept its property in perfect repair. It is well known that under such a correct business system, most landlords in tenement housing could show no profit at all. In fact, for a long time the achievements of the City and Suburban Homes Company lay rather in the fields of finance and management, and only in recent years has it departed far from older types of design. Another fact may be mentioned about this company. It has successfully provided housing for negroes, one of the most difficult ventures in the housing business.

Another company should be mentioned—this is the Queensboro Corporation. The Queensboro Corporation is much the same type of corporation, with the same fine spirit of enterprise. Its field is among a higher economic class of tenants whose incomes range from \$3,000 to \$10,000 per family.

These are the two organizations that have done the most to develop the new type of multiform housing—the garden apartment. As a result of their large, successful developments the block has

been discovered to be the true economic unit of planning. Besides this important principle, they have contributed another, even more striking one. This is that it is no economy, if indeed it may not cause an actual loss, to build on much more than 50 per cent of the area of the lot, in spite of the fact that the law of 1901 allows 70 per cent of the lot area to be covered by construction on interior lots, and much more than 70 per cent on corner lots.

This second principle — that it does not pay the investor to build on more than about one-half of the lot—deserves the most careful examination, since the explanation of it may differ in different cases, for conditions are different in different classes of housing. Proceeding to the illustration of the first principle—that the block is the true unit of municipal housing—this is shown in diagram "J." This is a plan of a typical New York block, of long narrow shape. The ends of it are reserved for commercial structures and the remaining space is occupied by ten apartment houses. This block of buildings was designed by Andrew J. Thomas, architect for the Queensborough corporation, and is just completed. Illustrations of it will appear in the August issue.

It is evident that the block has been designed as a whole in a simple, but comprehensive, and highly coordinated architectural design. All the buildings have been set back from the lot and building lines, permitting shallow terraces along the streets. At the rear is a long open space about one hundred and twenty feet wide, running between all ten buildings, for outdoor gathering and for recreation. Its benefits are apparent when it is remembered that the streets are the only playground of New York children, including the children of the rich; even the luxurious Park Avenue apartment houses make a poor showing in this respect. At the bottom of each rear open court is a covered space for garages, reached by the service ways that run between the buildings, and which have the additional function of providing five alleys of circulation



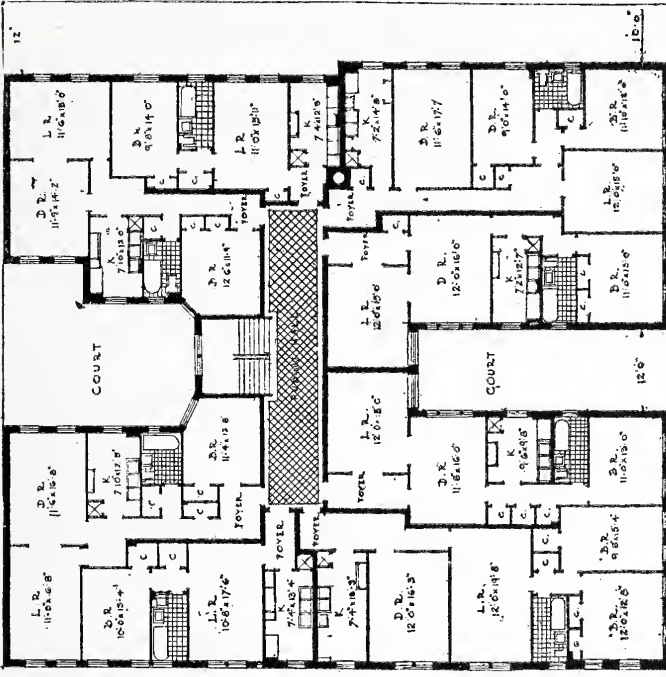

ST. NICHOLAS AVENUE

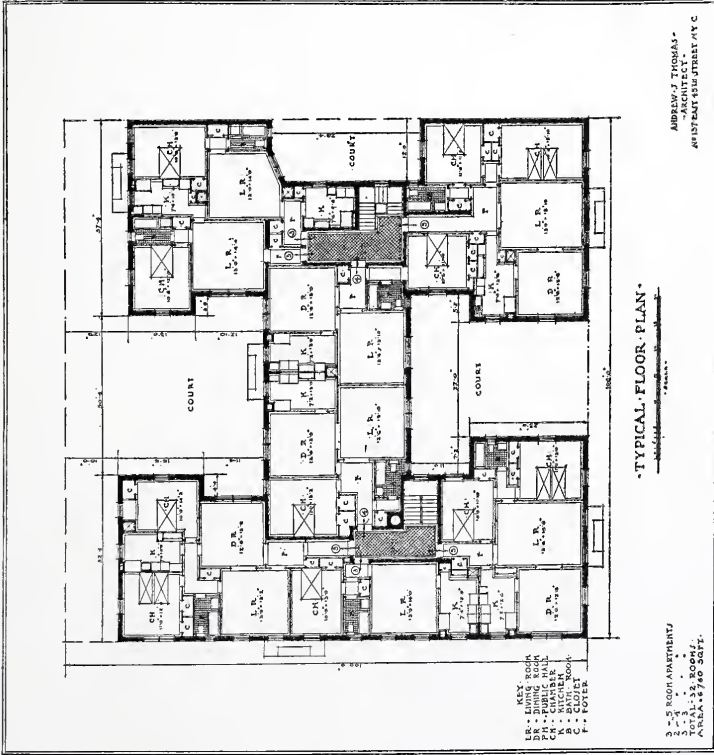

DIAGRAM F.—TWO CHARACTERISTIC NEW YORK APARTMENT HOUSES, OF WIDE FRONTAGE, BUILT UNDER ACT OF 1901. OCCUPIED AREA COMPRISES  $7\frac{5}{8}$  SQUARE FEET, OR 78% PER CENT. OF THE LAND.

through the block. Of the frontages on the street, the center house of the row is one hundred and seven feet in width along the street, and the two end ones eighty-three feet. Further details of these buildings will be taken up later, but from this short description their character is clear. It is evident that, from the point of view of convenience, comfort, cheerfulness, even of beauty, this group closely approaches an ideal type of housing once it is admitted that the average city dweller can not afford an individual house and lot, but must live in multiform houses because of the high cost of land and of fire-resisting construction required in cities. As architecture goes, it could hardly be improved on.

But, it will be objected at once, without doubt this is a magnificent ideal, but is it practical? Can it be constructed at a price that the average city dweller can afford to pay. Can it compete in rentals with the types that cover 70 per cent of the lot or more? It is here that Mr. Thomas's second principle comes into play, that it is no gain, but may even be a loss, to build on more land area.

This principle seems indeed a paradox. Most minds cannot believe it when they first encounter it. Mr. Thomas explains it as a matter of design, and the Housing Committee of the Reconstruction Commission of the State of New York adopts his statement in their exhaustive Report of March 26, 1920, on "Housing Conditions in New York." Their figures are based on another plan prepared for them by Mr. Thomas, shown in Diagram "G," and are as follows, quoting from the report.

"The Thomas plan, as per sketches attached, shows the following, on an inside plat 100 by 100, five-story building:

Number of rooms on a floor.....	22
Number of rooms in a house.....	108
Percentage of lot covered.....	33½%

"In the typical five-story apartment, built in 50-foot units in the plan common to the Bronx and Manhattan, the normal arrangements are as follows:

Number of rooms on a floor.....	36
Number of rooms in a house.....	176
Percentage of lot covered.....	70%

"Comparing the two plans, the result is as follows:

Typical plan, percentage of lot covered .....	70%
Thomas plan, percentage of lot covered .....	37½%

"The increase in lot area covered by typical plan compared to Thomas plan is 85 per cent. The increase in the number of rooms of the typical plan as compared to Thomas plan is 62½ per cent.

*Cost*

"House built on Thomas plan, on a plot 100 by 100, shows as follows:

Total cubic feet.....	241,000
Cost per cubic feet.....	30c
Cost of land.....	10,000

Total ..... \$82,500

"House built on typical plan, on a plot 100 by 100, shows as follows:

Total cubic feet.....	448,000
Cost per cubic feet.....	30c
Cost of land.....	10,000

Total ..... \$144,500

<b>Thomas Plan</b> —108 rooms, at \$9 per room per month.....	\$11,664
Cost of operation, estimated to equal 47% of the total income..	5,475

Leaving a net income (which is 7½% on the total cost)..... \$6,189

<b>Ordinary Plan</b> —176 rooms, at \$9 per room per month .....	\$19,000
Cost of operation, estimated to equal 47% of the total income..	8,900

Leaving a net income (which is 6.9% on the total cost)..... \$10,100

"In computing the cost of operation, figures were furnished by various of the larger builders and owners of moderate priced apartments, showing a cost operation of between 45 per cent. and 50 per cent. of the total income on the properties."

The report furnishes detailed explanation of how these figures were chosen and checked for construction costs. Costs are uncertain at the moment, as every one knows, but one should also realize that the higher the factors for construction and maintenance are, the more favorable do they show the Thomas plan to be. It should be further emphasized that builders experienced in such work checked over these figures for construction, and that some of the ablest real es-



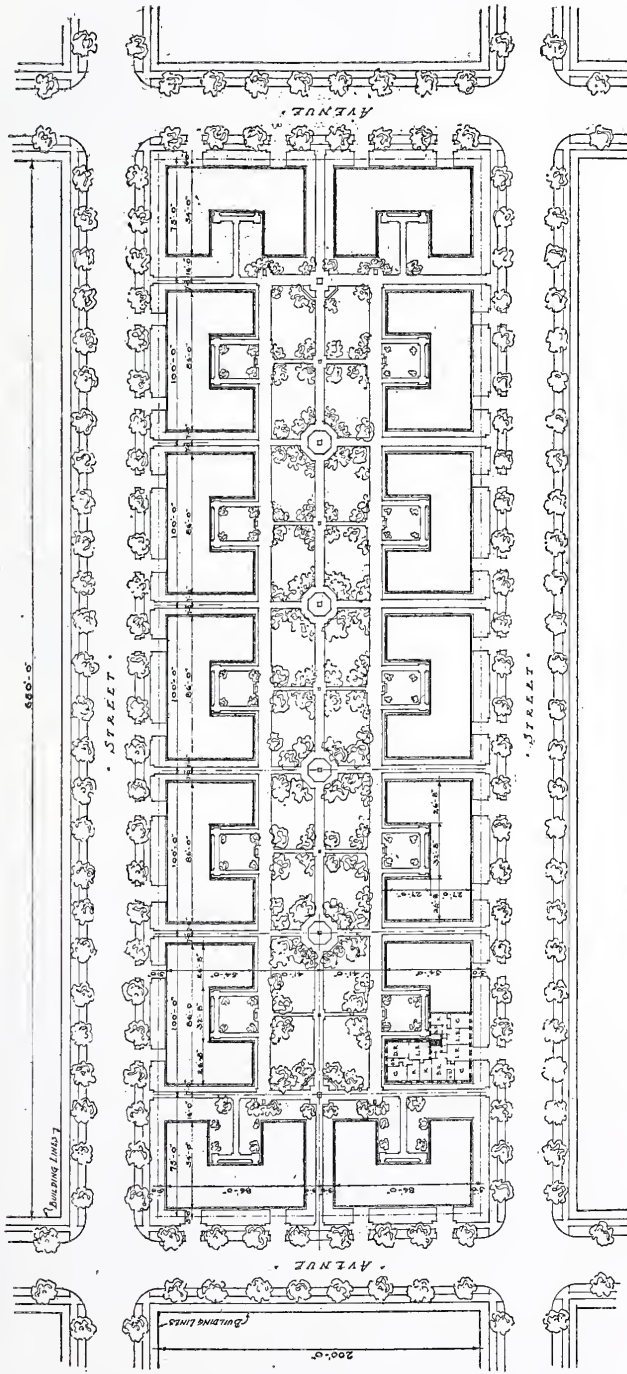

STUDIES FOR AN IMPROVED, DEVELOPMENT  
OF FIVE STORY TENEMENTS

PREPARED FOR  
THE RECONSTRUCTION COMMITTEE

ANDREW J. THOMAS  
ARCHITECT  
137 EAST 45th ST. N.Y.C.

- 14 HOUSES
- 420 APARTMENTS
- 1540 ROOMS
- 57% OCCUPIED BY HOUSES
- 66% LIGHT AIR AND RECREATION

DIAGRAM G.—PLAN OF GARDEN APARTMENTS FOR A NEW YORK CITY BLOCK, PREPARED BY ANDREW J. THOMAS, ARCHITECT FOR THE NEW YORK STATE HOUSING COMMITTEE.

Scale 1/8" = 1'-0"

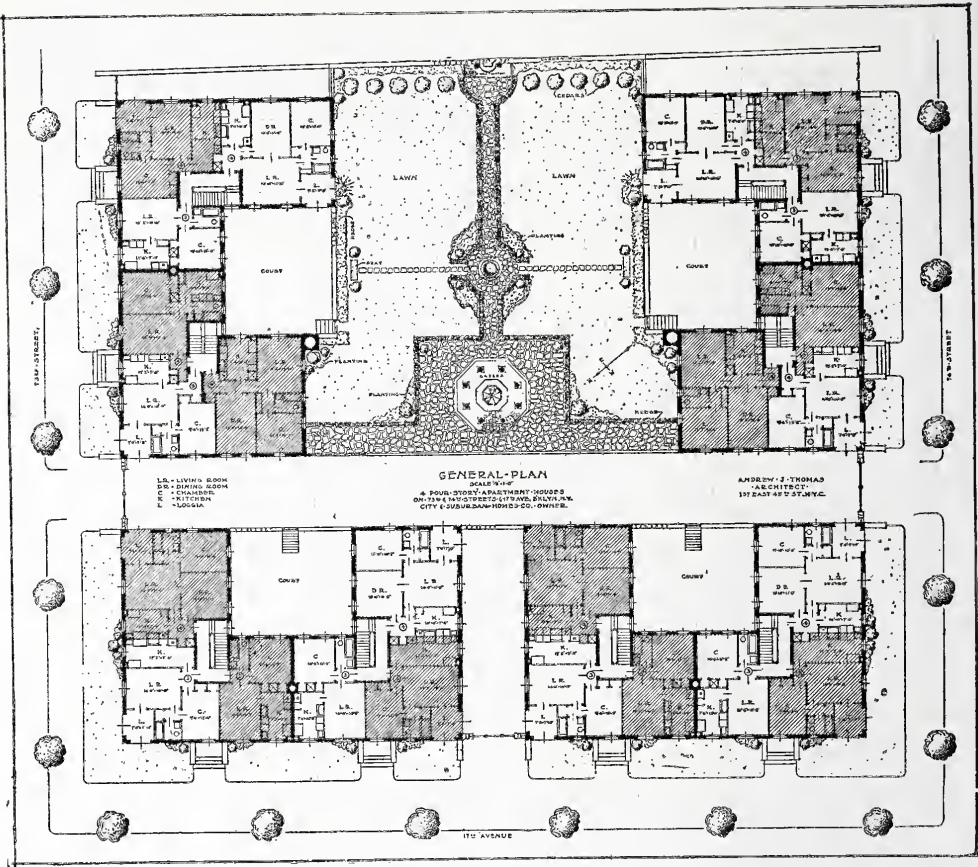

DIAGRAM H.— PLAN OF GARDEN APARTMENTS FOR CITY AND SUBURBAN HOMES COMPANY, ON SEVENTEENTH AVENUE, BROOKLYN. ANDREW J. THOMAS, ARCHITECT.





MODEL OF GARDEN APARTMENTS FOR CITY AND SUBURBAN HOMES COMPANY,  
ON SEVENTEENTH AVENUE, BROOKLYN.

tate experts in the field of renting and managing apartment houses approved the figures for income.

The secret of this paradox of design is a simple one: It is merely that Mr. Thomas has so compacted his plan, eliminating so many needless elements of entrances, and particularly of stairs, fire-escapes, corridors and passageways, both public and those within individual apartments, that the cost, of both construction and management, of these non-rent paying spaces is reduced to its lowest point.

If the number of rent paying rooms be increased much above this point, the plan becomes quickly more complicated

and the proportion of this non-rent paying space increases greatly, out of relation to the rest. Then the interest on their added cost more than offsets the increased net rent return on the additional rooms which may be gained by building on more of the lot area. It is, in a sense, an illustration of the old principle of the "law of diminishing returns."

This is the explanation of Mr. Thomas of the truth of his principle and he is backed in his conclusions by the opinion of some of the ablest real estate experts in New York City. As we have seen, it is founded on considerations of design. But it may be challenged as being



MODEL OF GARDEN APARTMENTS FOR CITY AND SUBURBAN HOMES COMPANY,  
ON SEVENTEENTH AVENUE, BROOKLYN.

YARD 26x108

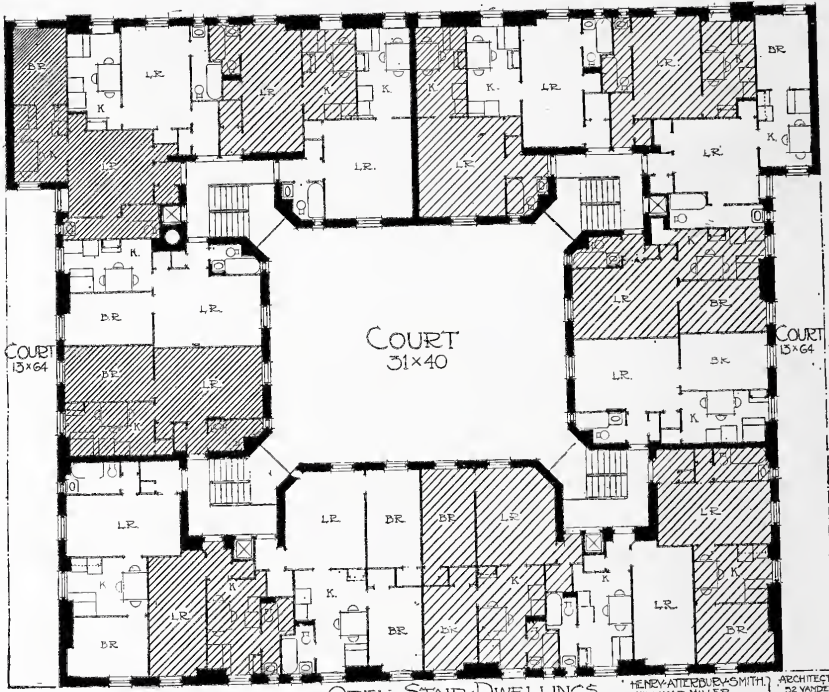

OPEN-STAIR DWELLINGS  
WEST 146th & WEST 147th STREETS  
NEW YORK

HENRY ATTERBURY SMITH ARCHITECTS  
WILLIAM P. MILLER, D.R. VANDERBILT AVE.  
N.Y.C.

OPEN STAIR DWELLINGS 211 WEST 146th ST. NYC

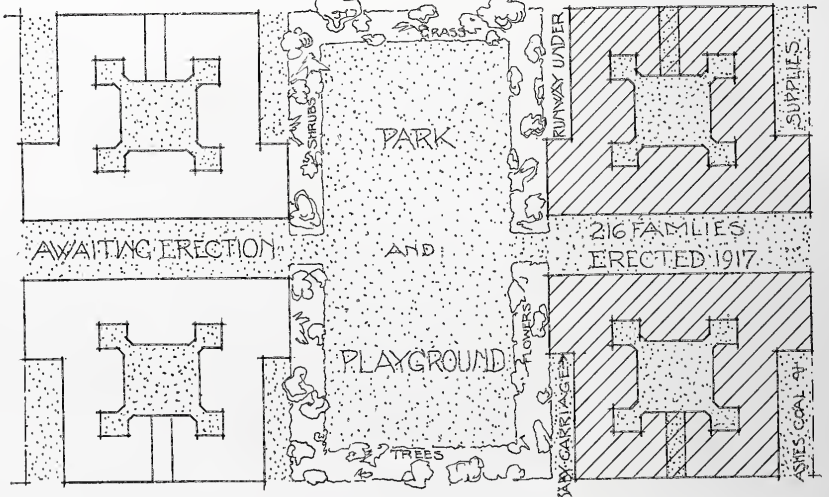

52% OF PLOT OPEN

DIAGRAMS I AND J.—UNIT PLAN AND BLOCK PLAN OF OPEN-STAIR GARDEN APARTMENTS ON WEST 146th AND 147th STREETS, NEW YORK CITY. HENRY ATTERBURY SMITH AND WILLIAM P. MILLER, ARCHITECTS.



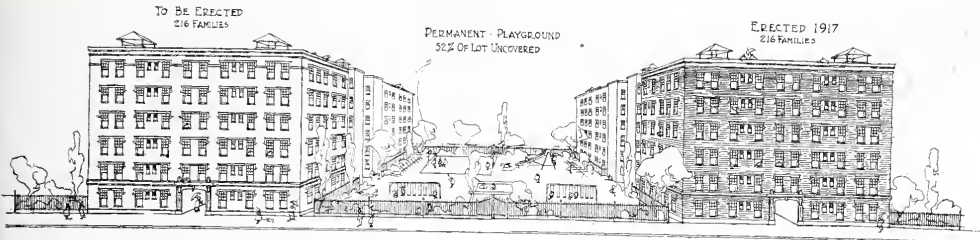

PERSPECTIVE OF OPEN-STAIR APARTMENTS ON WEST 146th AND 147th STREETS, NEW YORK CITY.

almost too simple to meet all cases, and for this reason it is well to point out that there are other factors on the financial side which tend to bear it out. Briefly these factors rest on the proportion of value of building to value of land, and they involve also management and the rental value of light and air.

In regard to the first factor, the value of land is nearly permanent, but a building depreciates and becomes obsolete in

one way or another. Mr. Allan Robinson, President of the City and Suburban Homes Company, brought this truth out admirably in his annual report of the company in 1917. As noted before, one of the achievements of this organization was to introduce modern accounting into New York real estate. Formerly it had been the custom to expect that depreciation would be offset by increasing land value. This was pure assumption, and



FIRST UNIT ERECTED—OPEN-STAIR APARTMENTS ON WEST 146th AND 147th STREETS, NEW YORK CITY.

Henry Atterbury Smith and William P. Miller, Architects.

experience proved the fallacy of it. Since land value is permanent or may increase, while building value should be amortized even in high class construction after forty-five years, it is not sound policy to have the proportion of building value to land value too high. The investment becomes too top-heavy; also, any increase in land value will not be felt so much in the value of the whole investment. In addition, less capital is risked in one operation where too great concentration is not attempted. Therefore, if housing is to be conducted on a large scale, in order to insure best results of planning and construction and finance, it may not be wise to over-capitalize the buildings.

Considerations of management also favor less concentrated building. The experience of both the City and Suburban Homes Company and the Queensboro Corporation is that larger properties are easier to manage. Tenants respond to the environment of a beautiful garden apartment and take great pride in keeping up the premises. This, in turn, causes the management less work and, what is more, it makes the depreciation item less on the books.

Still a fourth reason in favor of less congested building comes on the rental side. In the garden apartments, all suites of rooms are desirable, those on the rear being the most sought after; hence these buildings are always fully rented. On the other hand, whenever, as happens often, a surplus of housing occurs, the less desirable apartments on narrow courts or rear or side alleys of the older types of buildings are quickly vacated. The apartments on overbuilt land then are honeycombed with vacancies and become poor investments. To me this is one of the strongest arguments against overbuilding the lot area. It is most effective in cases of higher class apartments, but it may also operate with increasing power in cheaper apartments, especially as more and more garden apartments are built, with their superior attractiveness to tenants.

In fact, on a strict basis of design, superficially at least, Mr. Thomas's princi-

ple is somewhat endangered in one instance. This is the scheme of planning worked out by Mr. Henry Atterbury Smith, architect. His ingenious arrangement of stairs eliminates corridors and other non-rent-payment elements in the plan effectively. It is known as the "open-stair" type and appears in unit form in diagram "I." The point of this plan in relation to concentration is that four such units can be grouped together, forming a square building with hollow square enclosed court about 30 by 40 feet inside, with stairways in each corner of the court. Then these square buildings may be arranged side by side on a city block, with narrow side alleys separating the units, and back to back on a center alley running through the length of the block. Thus, to the extent that extra corridor space has been eliminated, this great concentration may be economically possible. If, however—and here is its weakness over the open garden arrangement—the majority of its apartments faced on small enclosed courts or narrow alleys, whenever tenants could find more desirable quarters elsewhere at not too great sacrifice, they would move out. The value of such a property is threatened in periods of competition.

Mr. Smith has used his openstair system—which, it should be pointed out, does not imply concentration—in a less congested scheme, half of which is built and has been operated successfully for some time, and which is shown in diagram "J." The hollow square arrangement of the units referred to above is seen here.

I have entered at such length into the question of concentration, because it will doubtless cause controversy not only as a general principle, but as regards each single case. For this reason I prefer to set it forth on a broader basis than in the report of the New York Housing Committee, and to include factors of finance and relation of value of building to value of land, of management and of rental which they have not seen fit to include, but with which, of course, the experts of the Committee are familiar. On a wider basis, the different factors



• YARD •  
64'-3" x 75'-0"

• LOT • 64'-3" x 150'-0" •

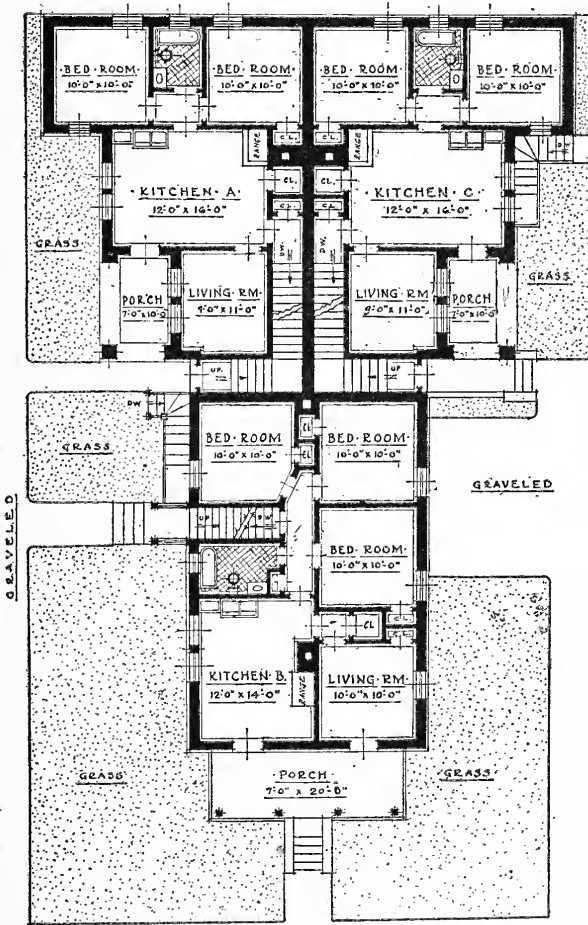

• 3 • TWO • FAMILY • HOUSES •

• ERECTED ON WEST 239<sup>TH</sup> STREET •

• NEW YORK CITY •

• CLARENCE S. STEIN •  
• ARCHITECT •

• 56 WEST 45<sup>TH</sup> ST. NEW YORK CITY •

DIAGRAM K.—PLAN OF UNIT—GARDEN APARTMENTS IN BRONX BOROUG, NEW YORK CITY. CLARENCE S. STEIN, ARCHITECT.

seem to bear out one another and they thus emphasize the relationship between the two principles that, in both design and economy, the block is the unit of multiform housing, and that it is not financially sound policy to build on much more than one-half the ground area, leaving the rest to be used as recreation space instead of depending on the streets for that purpose. With these two great ideas of his Mr. Thomas's demonstration is an historic event in city housing. Truly, how far we have come from the old railroad and dumbbell types of tenement houses that were built scarce twenty years ago!

Only one more objection against the garden apartment remains to be considered. It is asked, how can the speculative builder who has provided most of the tenement housing handle such large scale financial operations? It may be said at once that if he insists on following his former methods, probably he cannot. This opens up the whole question of the existing shortage in housing, which may not be treated here, except to say that if in building, as in other industries, large scale methods and sound accounting require a revision of old unscientific practices, doubtless these old methods will be revised. For one thing, even in the private real estate field, the cooperative system of financing is being developed as offering a surer and untapped source of capital. Cooperative investors insist on much sounder methods of finance, and it is well known that much of the success of speculative methods lay in the fact that investors in that type of buildings had none too clear ideas of accounting. They were too willing, as noted before, by not charging off depreciation and obsolescence on the books, to accept fictitious profits.

Leaving the bearing of Mr. Thomas's site unit upon city planning until later, it is to be noted that his plans have a high degree of concentration. They house many people to the acre. They are an ideal for housing in areas of high-priced land like Manhattan Island where no further dispersion than this seems possible.

The next step is housing on land of

much lower value, as that in smaller cities, or in outlying districts of larger cities, like Chicago, Philadelphia, and even New York, where, as explained above, the row housing has been the type. Such a type is shown in diagram "K," which is a plan for houses constructed in the Borough of the Bronx, designed by Mr. Clarence S. Stein, architect, who is also secretary of the State Housing Committee. It will be thought of at first as a development of the Thomas scheme, but it should be understood in relation to the Philadelphia row housing and to the last link in the chain—the isolated and semi-detached standards of the small community. In other words, on a lot in size about 65 by 150 feet, Mr. Stein's plan could replace three houses of the block type or else two isolated houses with one apartment house containing quarters for six families. And, since each family has its separate entrance, the old American small town ideal of individuality and privacy is thus preserved to a degree, which is why the dwellings are only two stories high. With more stories, separate entrances could not be had. Then by combining this type with another type in alternate units in a group, the architect achieves the benefit of the garden apartment idea, a point of superiority over the best Philadelphia type of the Octavia Hill Association (Diagram "D") or its best derivative, the Murphy & Dana arrangement (Diagram "E"). Still another merit of this scheme is this: a lot sixty-five feet wide is really too small for two isolated houses, which are too close together on it for privacy and comfort. One of the defects of the individual dwelling is that as soon as land values rise, lots are narrowed and the little buildings are crowded close together.

Thus the account in outline of the development of city housing ends at a point where the different types tend to meet—the multiform New York type, the Philadelphia block type, and even the small town types, where the old free individualistic ideal in housing is still sought.

Only one further step remains to be recorded in this recent progress of city housing standards. This relates to the



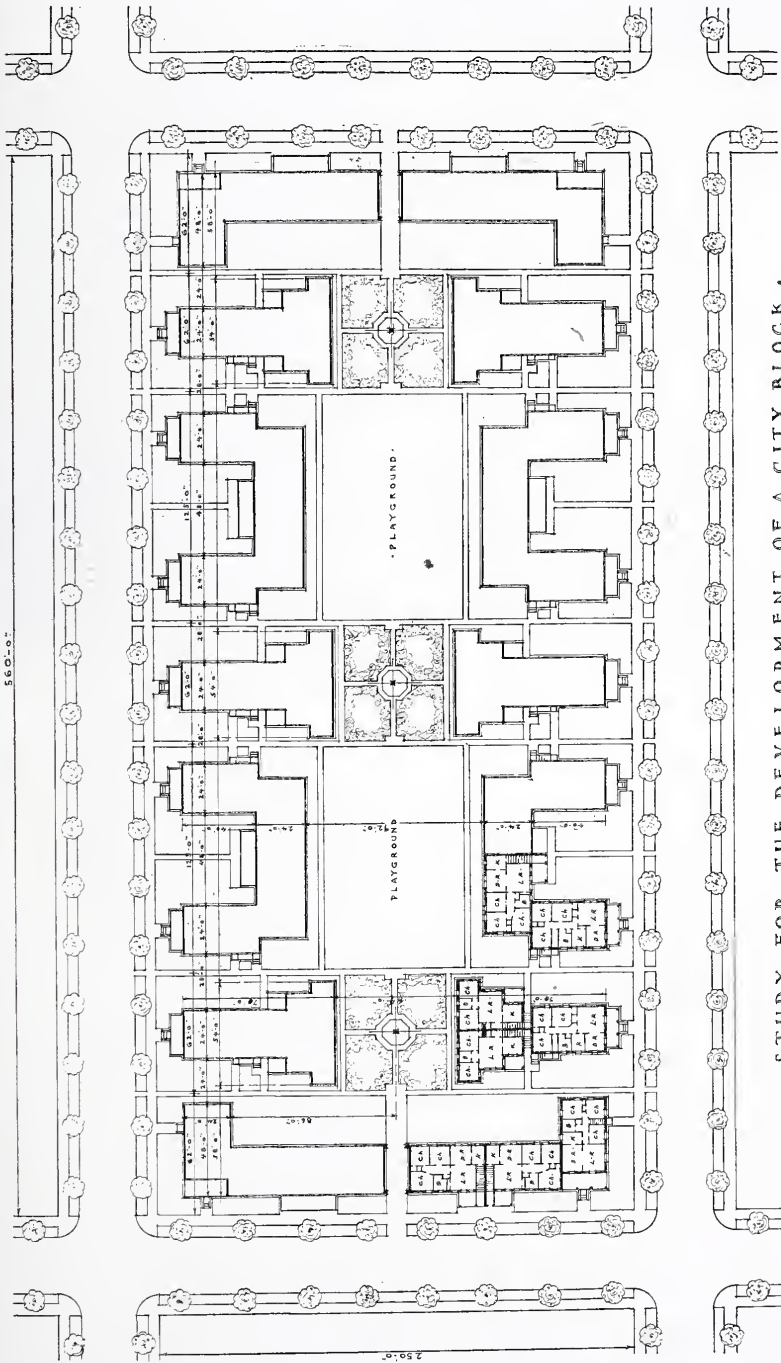

STUDY FOR THE DEVELOPMENT OF A CITY BLOCK.

WITH TWO FAMILY HOUSES.

SCALE 1/2" = 1'-0"

92 FAMILIES.

24-4 ROOM HOUSES.

68'-6"

AREA - 3/4 ACRES.

PREPARED BY CLARENCE S. STEIN ARCHITECT.

56' W. 45TH ST. NEW YORK CITY.

DIAGRAM. I.



GARDEN APARTMENT HOUSE IN BRONX BOROUGH, NEW YORK CITY.  
Clarence S. Stein, Architect.

most difficult matter of all to work out—the economic relation of housing to city planning. When the block is established as the true unit of multiform housing, the relationship becomes clearer. Here against one is not dealing with pure theory, because Mr. Thomas has provided still another practical principle, which concerns that disputed factor in housing and city planning, namely, land value.

Mr. Thomas declares that, above a certain figure, which is so low as not to apply in cities, land value should be given little consideration in multiform housing. His demonstration of this surprising conclusion is a simple matter of arithmetic, as follows:

An apartment house covers four and one-half city lots and contains 215 rooms:

4½ lots at \$10,000 equals.....	\$45,000
4½ lots at \$3,000 equals.....	14,000

Difference.....	\$31,000
-----------------	----------

Six per cent interest on \$31,000 equals \$1,860, which equals total added cost per year of apartment house caused by building it on land more than three times increased in value. This adds to cost of room per year \$1,860 divided by 215, or \$8.65; and adds to the monthly rent \$0.70, or say \$3 per month rent for a four-room apartment.

The added cost of \$3 per month for a four-roomed apartment caused by building it on high priced land, while it cannot be ignored, is not excessive. Its significance in housing however is that it represents, other things being equal, the natural difference in rental between apartments in denser city areas and apartments of the same class in outlying districts or suburbs. Now, when one perceives that this \$3 per month is almost exactly offset by cost of transportation at a five cent carfare—to say nothing of more expensive railroad commuting—its bearing on city planning becomes evi-



dent. It tends to prove that the daily double shifting of huge masses of workers about a great city is a real loss, a direct waste. It saddles on the city the enormous cost of an over-built, over-complicated transportation system, clogging streets and causing further indirect

be located within easy walking distance he may go home at noon for lunch—a further economy. Without going further into this argument, it would seem as if it vindicated that conception—the Garden City. The garden city in its essentials is a small city, having as a



DETAIL OF GARDEN APARTMENT HOUSE IN BRONX BOROUGH, NEW YORK CITY.  
Clarence S. Stein, Architect.

losses that cannot be estimated. The cost to the workers themselves, in time and annoyance, is only too well known.

In this light it would seem as if transportation of workers to and from work in factory and business is not necessarily an economy, but is a hardship, and that the worker should be housed within a walking distance of his work. If he

nucleus a center for factories and business, with housing grouped about—the housing located within walking distance of the work. In a large city, these small centers may be grouped around it like satellites, accommodated as far as possible to conditions of topography, main transportation routes and other factors. Some such arrangement would

seem to be the efficient one for the business and industrial city; and its practical development would need to be as carefully planned as any ideal small community, with the housing designed by blocks carefully established in the city plan. The further consideration of transportation, control of topography, restriction of zones for housing, business, industry and other activities of city life is but a slight step from this fixing of the city street plan, for naturally the city street plan in housing areas would be different from that of other areas.

Thus we have, as a result of these discoveries in multiform city housing, not only a new vital conception in housing, but one in city planning besides. Hitherto, like housing, city planning has been a matter of legal restrictions, as the New York Zoning Law of 1916. Wonderful a step or progress as it was, this law

is restrictive and negative. It is not in all respects constructive. Although, in large measure, it salvages and protects real estate values from chaotic conditions of speculation, even that it may not do absolutely, without other means to aid it. This truth is coming to be perceived. With the work of these architects in establishing the garden apartment as a practical business ideal, showing the false economy of too great concentration, both housing and city planning seem on the point of passing from a negative to a positive state of activity, and we may soon have practical standards for the mechanical and structural organization of the city comparable to the splendid models now provided the American people for the life of small communities where the old individual ownership ideal still is possible.

(To Be Continued)

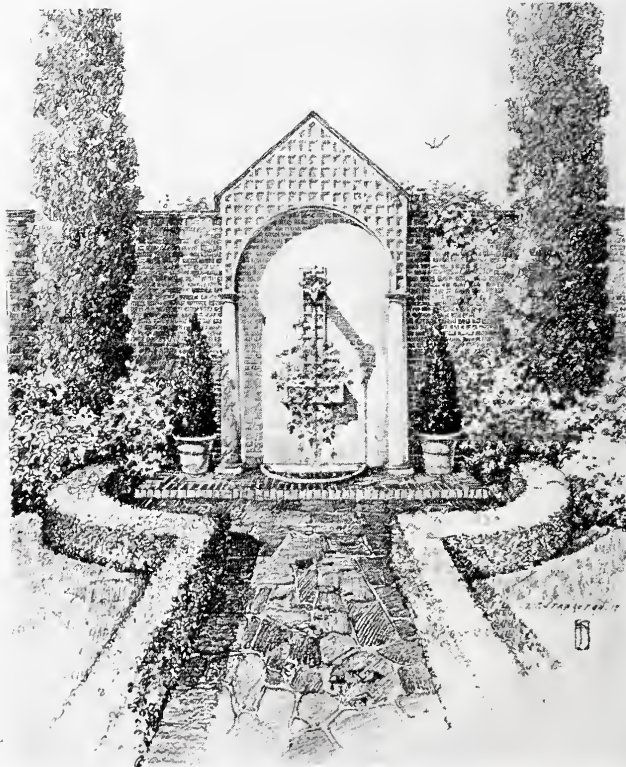

GARDEN DETAIL—GARDEN APARTMENTS FOR CITY AND SUBURBAN HOMES COMPANY, BROOKLYN.  
Andrew J. Thomas, Architect.



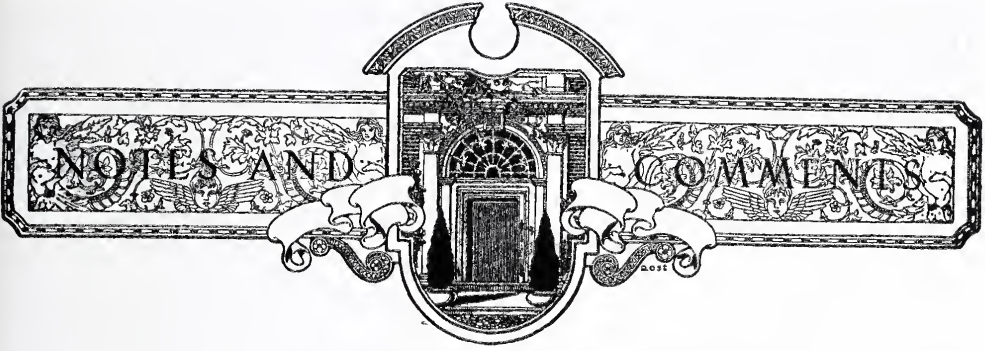

**The Proposed  
Nebraska  
State Capitol.**

The new State Capitol of Nebraska will be of interest to the architectural profession, on account of the unusual design that won the competition and because of the novel character

of the competition itself. In fact, the bold originality of the design may well have been due to the way in which the competition was conducted.

Ten competitors submitted plans to a jury of three architects—Messrs. Waddy B. Wood, James Gamble Rogers and Willis Polk. Their choice was confirmed by the Capitol Commission of the State, with whom Mr. Thomas R. Kimball acted as advisory architect. The architect selected was Mr. Bertram Grosvenor Goodhue, of New York.

The distinctive feature of the competition was that the commission—following the advice of the architectural jury—announced that it did not agree to accept the winning design, but it did agree to employ the architect of the winning design. The commission, therefore, sought an architect rather than a design, and in so doing it was able to draw up the terms of the competition in a broad, free way and bring out the best ability of the designers.

Thus Mr. Goodhue's design, as here shown, is not necessarily the design as it will be carried out. It is rather a preliminary scheme and much further study will be given to the problem, with possible changes even in essentials. Its development may prove most interesting to follow in the future.

As will be noticed, the drawings show anything but the dome-palace-portico formula, or modified St. Peter's, that has become the custom for State capitols, derived as they are from the National Capitol

at Washington. The plan is a vast square, with a cross dividing it into four interior courts. In the center a monumental entrance vestibule leads into a huge memorial hall, through which one passes into the great rotunda in the center, under the tower, out of which open, left and right, the vestibules of the two legislative chambers. Behind this rotunda, in the space corresponding to the memorial hall, are antechambers of the legislative organization, consisting of the large reference room, pressrooms, etc. The State courts have a position of honor along the other front, opposite the main entrance, with rooms serving the court organization and the judges occupying all this façade and extending around on the sides of the building. Various other rooms, including a suite for the Governor, and committee rooms and offices, complete the plan. On the whole the scheme is conceived in a splendidly monumental way.

The most original feature of the design is the exterior. A long horizontal one-story building, raised on a long podium or base, its fine ample wall surfaces not too broken by windows, has as a principal feature a great center entrance motive, reminiscent at once of a Greek propylæum and an Egyptian temple entrance of pylons. From the midst of this long, low group rises a huge bold tower, nearly 400 feet high, which is the stackroom of the library. In style the design might be called neo-Greek, with occasional motives of Roman or modern origin. It is much in the spirit of the Greek revival that became popular the world over about the middle of the last century. But, although in details it reveals no conceptions that are strikingly unusual, its mass is remarkable as could be, and its motives are a welcome relief from the perfunctory formulæ of long colonnaded and pilastered façades, relieved

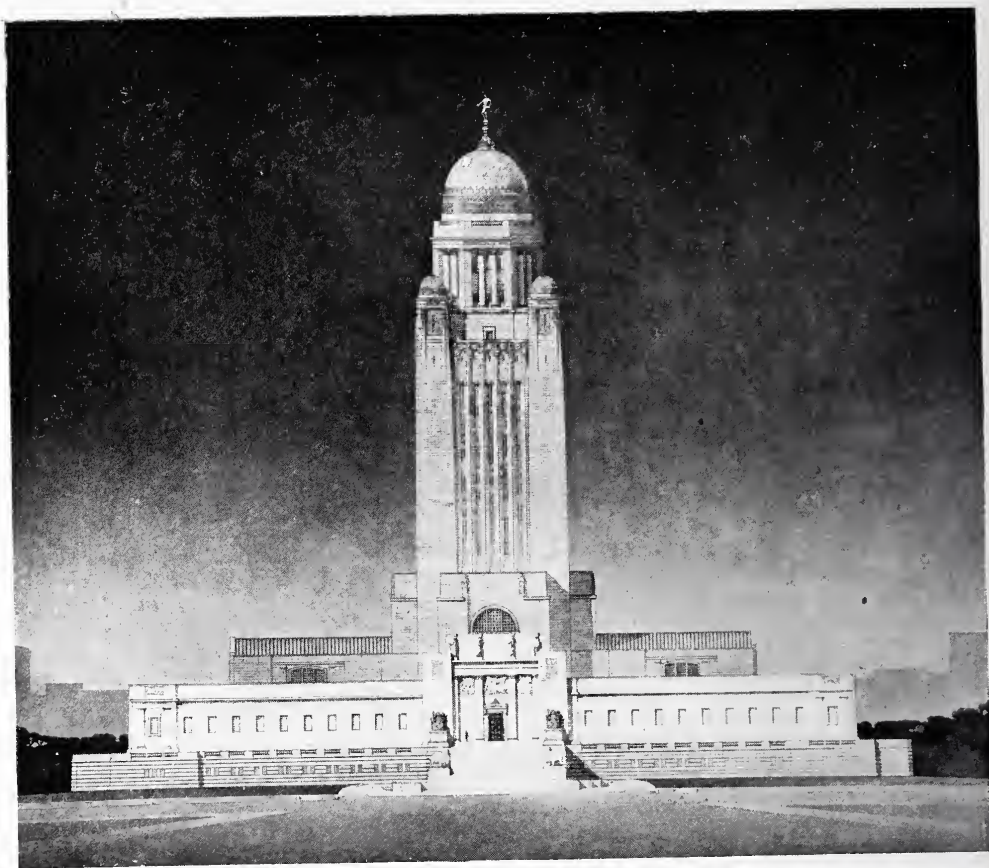

WINNING DESIGN FOR NEBRASKA STATE  
CAPITOL, LINCOLN, NEB. BERTRAM  
GROSVENOR GOODHUE, ARCHITECT.



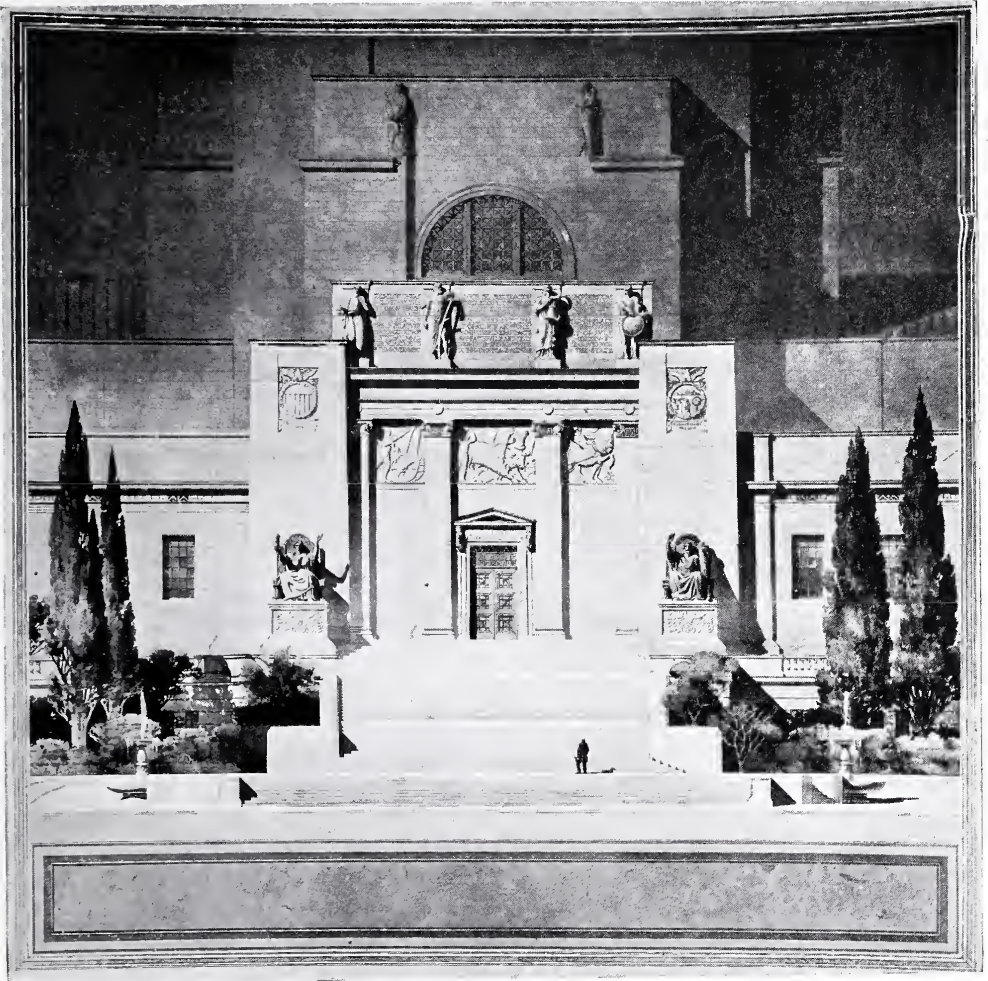

ENTRANCE — WINNING DESIGN FOR THE  
NEBRASKA STATE CAPITOL, LINCOLN, NEB.  
BERTRAM GROSVENOR GOODHUE, ARCHITECT.

only by a central portico or by end pavilions, that have atrophied monumental architecture in America.

It is evident that this new scheme has not progressed far enough to draw many conclusions about it from these drawings. How its huge vertical tower rising from the center of the long level group will look in perspective in relation to that group, one does not know. Only a long study of models can give an inkling as to that. But however difficult it is to read the future facts of mass and perspective from these competitive drawings of the Nebraska capitol, one feature of it is already evident—that is its splendid monumental character. It is a fit emblem of the greatness of a State. In its final form we may look forward to seeing in it another virtue that Mr. Goodhue has been able to inspire in his architecture—the illusion of life and warmth in stone and metal. All who saw his group of Fair buildings in California brought back tales of the splendor of perfectly keyed color and rich decoration, all vibrating in sunlight. Too often this air of vitality and glowing color,

which was the very symbol of Attic art, is lost in the modern architecture that is derived from antiquity. Our monumental architecture comes almost solely out of books, where ideas of form may be derived, but ideas of color, never. Greek architecture without color is like a body without blood in it—a mummy that should be left in the tomb. Books were the last place where the Greeks thought of creating architecture. They always formed it out in the landscape, in shapes of color in sunlight.

ROBERT IMLAY.

**Memorial Tablets.**

The designing and inscribing of memorial tablets, no matter how modest these may be, require of the designer conscientious attention. In such a spirit Mr. Elettus D. Litchfield wrought the beautiful Greenleaf Clark tablet of bronze and marble in the St. Paul Public Library.

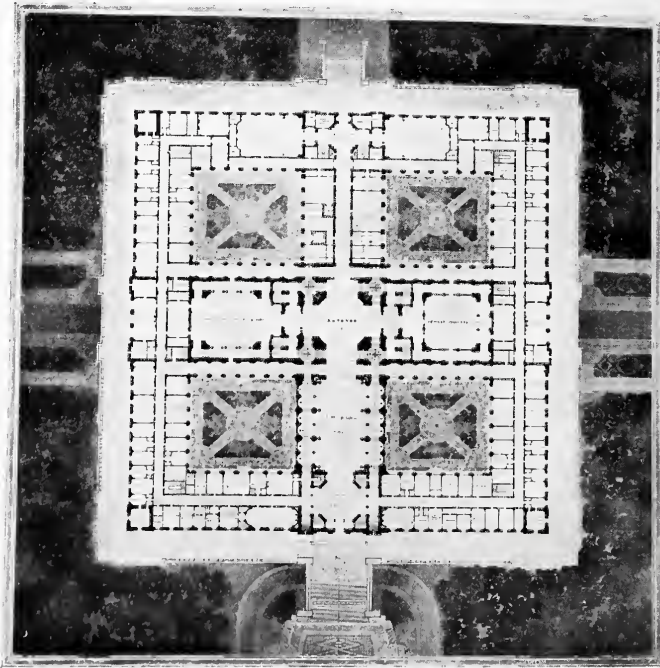

PLAN—WINNING DESIGN FOR NEBRASKA STATE CAPITOL,  
LINCOLN, NEB.

Bertram Grosvenor Goodhue, Architect.



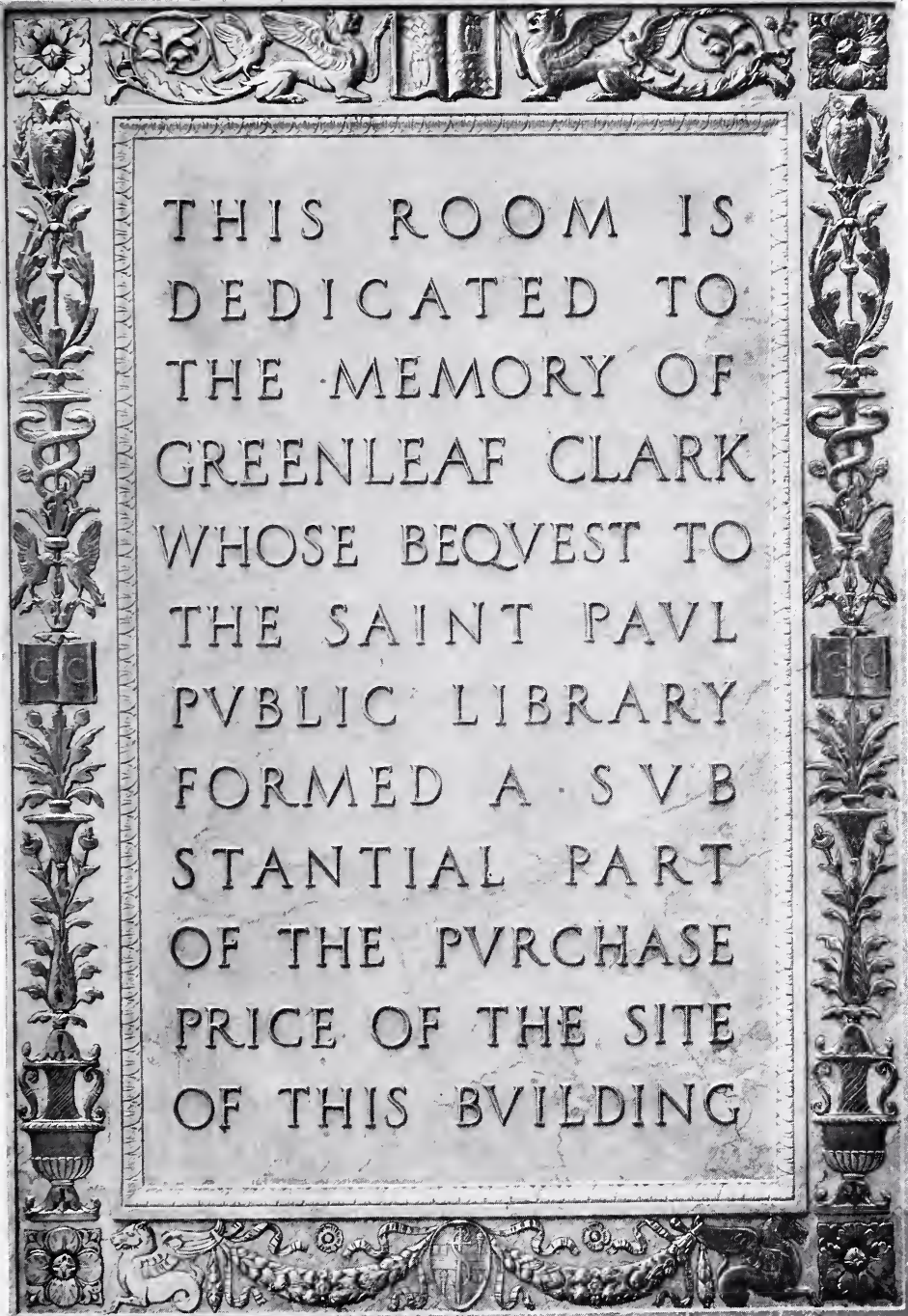

THIS ROOM IS  
DEDICATED TO  
THE MEMORY OF  
GREENLEAF CLARK  
WHOSE BEQUEST TO  
THE SAINT PAUL  
PUBLIC LIBRARY  
FORMED A SUB-  
STANTIAL PART  
OF THE PURCHASE  
PRICE OF THE SITE  
OF THIS BUILDING

TABLET IN MARBLE AND BRONZE, ST.  
PAUL (MINN.) PUBLIC LIBRARY.  
ELECTUS D. LITCHFIELD, ARCHITECT.

Its beauty is evident. There is both the exquisite ornament of the border and the pattern of the lettering, simple in their classic grace and richness. The tablet, about thirty inches by fifty inches, is of Hauteville marble, whose color is like dark old ivory, though grayer. Its decoration of bronze ornament and letters, these being light green gold, are inlaid in the stone, for security, and they project slightly beyond the surface to yield the effect of low relief. The photograph shows the relative values of color truthfully.

Such a masterwork as this makes evident the need of a beautiful tradition of tablets and of lettering in American art. It seems strange that people do not yet know the richness of our native tradition in this field. We are fortunate in our present day design with a few examples like this of Mr. Litchfield's, which recalls the perfect tablets of the old Italian tombs. And besides that, we have our early American tradition—extraordinary both in its classic perfection of the letters of the Roman alphabet, in which it is surpassed only by the Italian masters, and in its unique use of the decorative effects of the small alphabet and of the flowing, brushlike curves, like handwriting, of the numerals of the dates. The older American churchyards contain countless examples of this art in their headstones, and one wonders why their significance is overlooked. If the reader will turn to the issue of the Architectural Record for December, 1916, he will find there

photographs of a few of these headstones of a hundred years ago, taken in the graveyard of Trinity Church, New York City. The old models show the rare, unusual personality of craftsman's art, which is only slightly excelled in pure beauty by the classic cuttings of the early Italian masters.

JOHN TAYLOR BOYD, JR.

**Thrusts  
Over  
Voids.**

In the June issue of the Record, in an article by J. R. Reid, I find the following statement attributed to me in relation to Mr. Bourgeois's design for the Bahai Temple of Peace: "The

first new idea in architecture since the thirteenth century." Exactly what I said in the course of a half-hour address, and a cross-fire of questions thereafter, I do not remember, but I do know that I did not make the statement attributed to me above. I did say that I had never seen anything quite like it; that it was referable to no style with which I am familiar, but it seemed to belong to the school of which Louis Sullivan is the leader and chief exponent. I also said that I should like to see "how it would work out in execution," and I strongly advised that when executed the upper part be revolved on the central axis so as to bring the apparent thrusts of the upper buttresses to the angles of the lowest story instead of over the voids.

H. VAN BUREN MAGONIGLE.



THE  
ARCHITECTURAL  
RECORD

AVGUST 1920



PUBLISHED IN NEW YORK  
35¢ A COPY \$ 3.00 A YEAR

# BISHOPRIC SHEATHING

Put to Rigid Tests by—

OMAHA CITY OFFICIALS

## Proves Merit — Wins Commendation

*A test of strength of different plans of frame construction has just been completed by the City Building Department of Omaha, Nebraska, in the presence of fifty of the most prominent architects and contractors of the city. The tests were supervised by City Building Inspector R. E. Edgecomb.*

ACCORDING to those present the comparison which attracted the most attention was that between the accepted "wood sheathing" plan now used in Omaha and "Bishopric" sheathing, which heretofore has not been permitted in Omaha because of its supposed lack of strength. Under a strain of 2100 pounds the wood sheathing panel simply went to pieces as a complete wreck, the deflection being 5 7/8 inches, while "Bishopric" sheathing showed a deflection of 1-9/16 inches under the same strain.

The following comments were made by those who witnessed the tests:

Mr. HARRY LAWRIE, A. I. A., 619 Paxton Block, Omaha.—"I have specified BISHOPRIC products in many of my plans, but I attended the test made in Omaha because I wanted to

### BISHOPRIC

**BISHOPRIC SHEATHING**—Strengthening, insulating, sound-deadening, weather-proofing unit; for exterior walls, sub-flooring and sub-roofing.

**BISHOPRIC STUCCO BASE**—Interlocking dovetailed key, insulating and waterproofing unit; crosote treated and not treated; for exterior. Applied direct to the studding or over BISHOPRIC sheathing.

**BISHOPRIC PLASTER BASE**—Interlocking dovetailed key, insulating, moisture-proofing and sound-deadening unit; for interior plaster walls and ceilings.

know, first hand, just what the BISHOPRIC products could stand. I knew they were strong, but I was surprised. According to the results of the test BISHOPRIC sheathing in strength compares with ordinary wood sheathing as eleven to three—or BISHOPRIC is about three and one-half times as strong as wood sheathing. The

use of BISHOPRIC sheathing will materially cheapen the cost of construction and will add materially to the strength of the building. The saving is in both cost of materials and on carpentry work.

Mr. A. O. GUSTAFSON, Building Contractor, Omaha.—"I had heard of BISHOPRIC, of course, but I wanted to see an official test of its strength. It didn't take me long to make up my mind after I had seen this test. Hereafter I'm going to use BISHOPRIC, myself, and I'm going to recommend Bishopric to the people for whom I build houses. They can save money and get a stronger, better house.

Mr. J. W. RASP, of RASP BROTHERS, 210 to 214 Keeling Bldg., Realtors and Builders, Members Omaha Real Estate Board.—"I was present at the Sunderland yards when the test was made of BISHOPRIC construction as compared with ordinary construction. Our firm builds a great many houses and we are going to build a great many more. Rasp Brothers have never used BISHOPRIC, but I certainly was surprised and convinced at the result of that test. Our firm will certainly use BISHOPRIC in the future. The use of BISHOPRIC will cut down the cost of material as well as of labor. And that is what this country wants and needs. Of course, we must not save at the expense of the building, but by the use of BISHOPRIC we can both cut the cost of the building and increase its strength as well. I am frank to say that BISHOPRIC is the best stuff I ever saw."



Write for Special Booklet on Bishopric Sheathing.



The Bishopric Mfg. Company  
102 Este Avenue, Cincinnati, Ohio



# THE ARCHITECTURAL RECORD



CONTENTS

Vol. XLVIII. No. 2

AUGUST, 1920

Serial No. 263

*Editor:* MICHAEL A. MIKKELSEN      *Contributing Editor:* HERBERT CROLY  
*Business Manager:* J. A. OAKLEY

	PAGE
COVER—Design for Faience Panel in the Persian Style <i>By Leon V. Solon</i>	
A HILLSIDE HOUSE, the Property of George Howe, Esq., Chestnut Hill, Philadelphia: Mellor, Meigs & Howe, Architects <i>By Paul P. Cret</i>	83
THE CORTILE OF THE PALAZZO PERETTI, Rome. With Drawings by R. M. Kennedy <i>By Harold Donaldson Eberlein</i>	107
GARDEN APARTMENTS IN CITIES Part II (Conclusion). <i>By John Taylor Boyd, Jr.</i>	121
RECENT CIVIC ARCHITECTURE IN PORTO RICO: Adrian C. Finlayson, Architect <i>By Sylvester Baxter</i>	137
SOME DRAWINGS OF OLDER NEW YORK <i>By John Di Mariano</i>	159
THE ARCHITECT'S LIBRARY	166
NOTES AND COMMENTS	169

*Yearly Subscription: United States, \$3.00; Foreign, \$4.00; Single Copies, 35 cents. Copyright, 1920, by The Architectural Record Co. All rights reserved. Member Audit Bureau of Circulation.*

PUBLISHED MONTHLY BY  
**THE ARCHITECTURAL RECORD COMPANY**

115-119 WEST FORTIETH STREET, NEW YORK

T. S. MORGAN, Pres.      W. D. HADSELL, Vice-Pres.      E. S. DODGE, Vice-Pres.      J. W. FRANK, Sec'y-Treas.

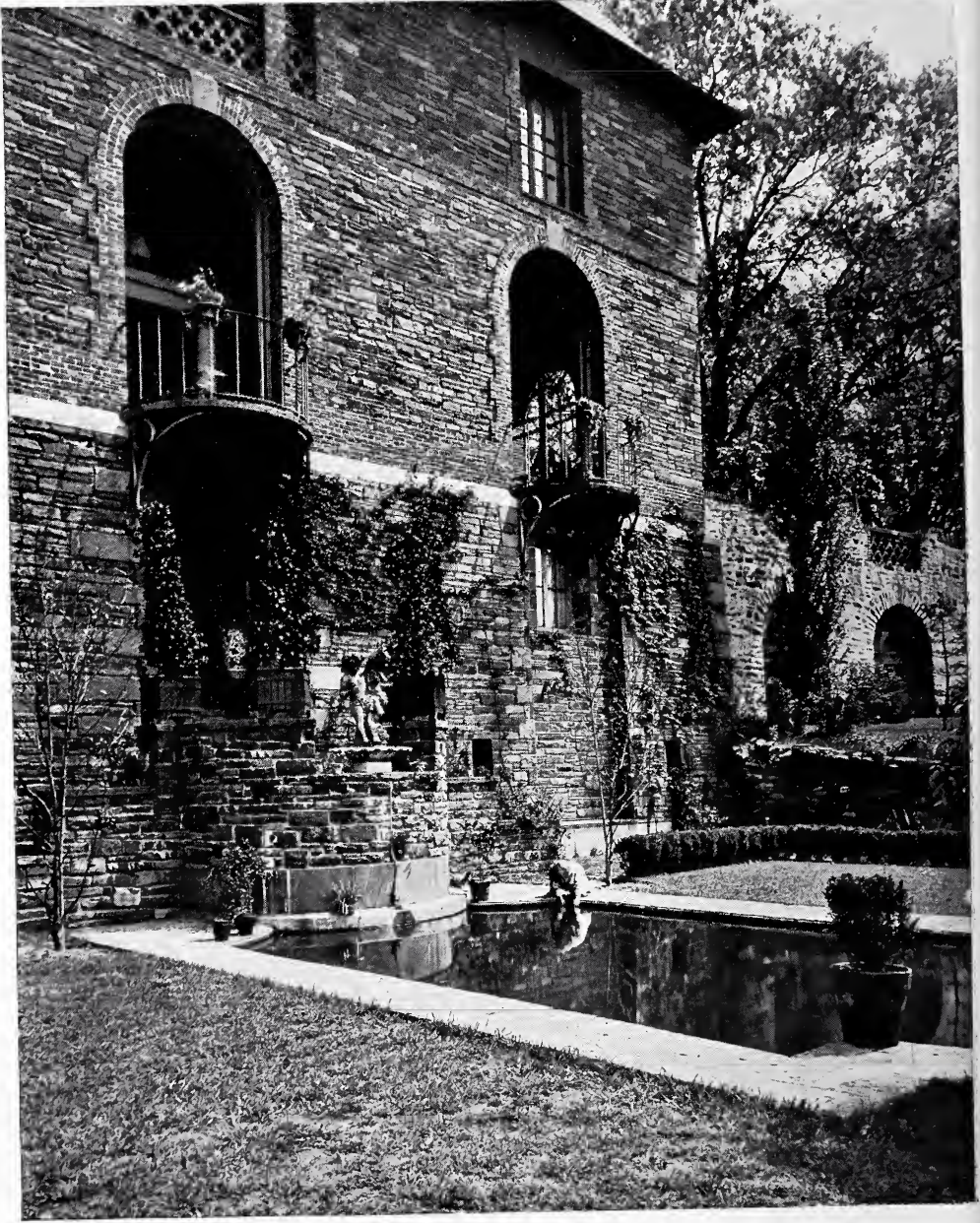

THE HOUSE FROM THE LOWER GARDEN (POINT OF VIEW 21 ON PLAN)—RESIDENCE OF GEORGE HOWE, ESQ., CHESTNUT HILL, PHILADELPHIA. MELLOR, MEIGS & HOWE, ARCHITECTS.



# THE ARCHITECTURAL RECORD



VOLUME XLVIII

NUMBER II

AUGUST, 1920

## ~ A HILLSIDE HOUSE ~ THE PROPERTY OF GEORGE HOWE, Esq. CHESTNUT HILL, PHILADELPHIA ~

*Mellor, Meigs & Howe, Architects*

BY PAUL P. CRET

FROM the terrace the lindens are outlined on a background of hills that one might suppose remote from all cities and human turmoil. Two other sides are enclosed by the woods rising at the rear of the grounds and the third by the house. The shadow of a giant oak, a bench against a hedge of hornbeam, and that same feeling of peace that reminds one of cloisters in Italy or of an eighteenth century garden in a sleepy provincial town of Touraine. Is there a better place to read? I wish I had had there that volume of Edgar Allen Poe, in which he develops his views on landscape gardening, as he most irrever-

ently calls it. Some passages would find their illustration right around. That one, for instance, in which he claims the superiority of the artificial style (which we nowadays call formal) over the natural style. ". . . . The artificial style has as many varieties as there are different tastes to gratify. It has a certain relation to the various styles of buildings. There are stately avenues and retirements of Versailles; Italian terraces; and a various mixed old English style, which bears some relation to the domestic Gothic or English Elizabethan architecture. Whatever may be said against the abuses of the artificial landscape-gardening, a mixture of pure

PLOT PLAN  
 PROPERTY OF GEORGE HOWE ESQ.  
 CHESTNUT HILL, PHILADELPHIA  
 ARCHT. & ENGRS. W. A. & A. BRIDGES

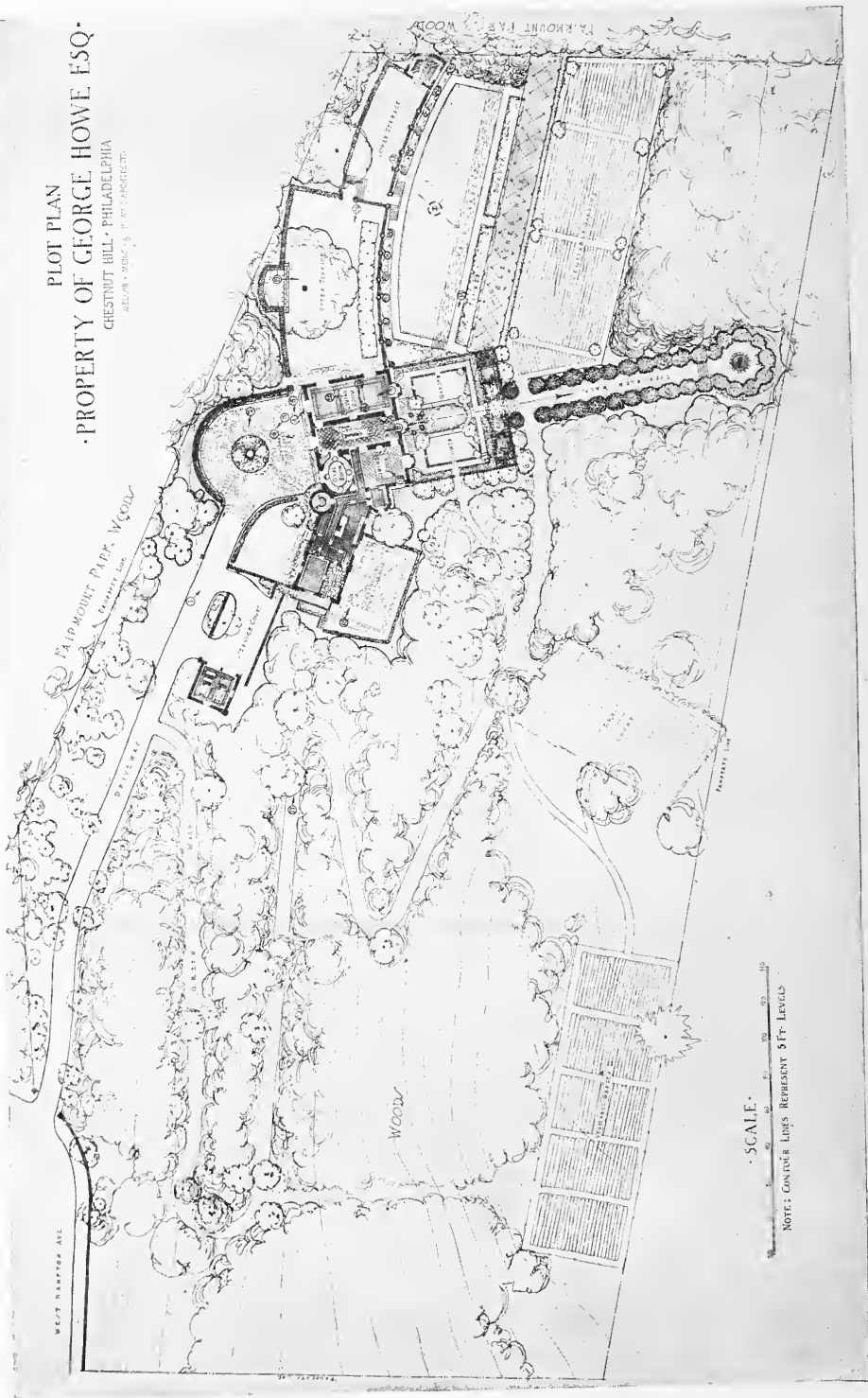

PLOT PLAN—THE CIRCLES WITH NUMBERS AND ARROWS INDICATE  
 THE POINTS OF VIEW FROM WHICH THE PHOTOGRAPHS ARE TAKEN.



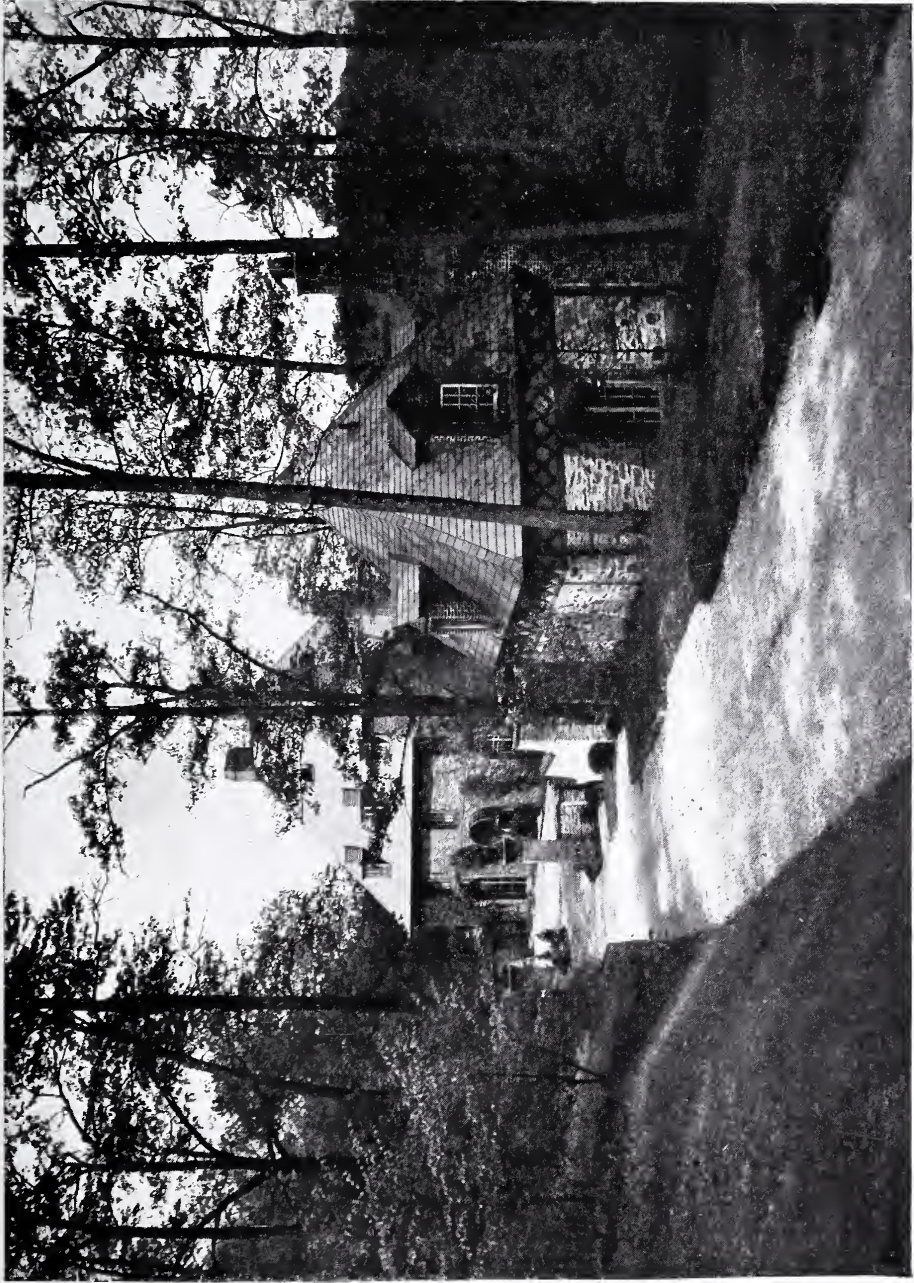

THE HOUSE FROM THE DRIVEWAY (POINT OF VIEW 1 ON PLAN)—RESIDENCE OF GEORGE HOWE, ESQ., CHESTNUT HILL, PHILADELPHIA. MELLOR, MEIGS & HOWE, ARCHITECTS.





THE FORECOURT AND GARAGE (POINT OF VIEW 2 ON PLAN)—RESIDENCE OF GEORGE HOWE, ESQ., CHESTNUT HILL, PHILADELPHIA. MELLOR, MEIGS & HOWE, ARCHITECTS.





THE FORECOURT AND WOODS.  
(Point of View 3 on Plan.)

art in a garden scene adds to it a great beauty. This is partly pleasing to the eye, by the show of order and design, and partly moral. A terrace, with an old moss-covered balustrade, calls up at once to the eye the fair forms that have passed there in other days. . . . Of course everything depends on the selection of a spot with capabilities."

Poe would have liked this setting of the house; a setting which is so skilfully selected that one forgets that it has been created in the last two or three years. It seems just as integral a part of the hill as the terraces and houses of Amalfi are of the cliff over the bay. The greatest achievement of art is to make itself inconspicuous. The terrace wall curves along to follow the contours, just as do those stone walls which retain the scarce loam of the vineyards. The service wing seems to have used an old foundation, as those houses rest on the old fortified gates of a city.

To find so perfect an example of a complete group, and above all of a group where the gardening, the architecture, the smallest details are exactly fitted to the importance and the character of the whole, is far from common. Look at the plan. There is almost no rectangular form; nothing seems to force itself on the natural conditions, and nevertheless there is everywhere that "mixture of pure art"

of Poe. It has that beauty of the village street that follows the capricious lines of a path of old, so superior to the relentless gridiron of our surveyors. It is picturesque without affectation.

For those who have followed the development of the art of Messrs. Mellor, Meigs and Howe, its most interesting feature has been precisely this progressive mastering of the charm, of the unconscious beauty of the minor domestic architecture of Europe. In each successive work there is a progress in the elimination of the "draughtsman picturesque" and a step toward that simplicity that is achieved only by the very few.

There is less and less of what could be called the bric-a-brac of architectural repertory, and in each case a stronger affirmation of individuality.

In this particular instance they had, it is true, the privilege of choosing a most remarkable site, for the owner is also the designer and a member of the firm. That is luck, but some one has said with reason that opportunity knocks only at the door of those who know how to receive it. With a property of moderate size, within the city limits, the boundaries of a public park have been used to such advantage as to incorporate the park woods in the composition. In going over the grounds, one does not realize the limited extent of the estate, neither does one wish for other conditions. There is no need for an apology.

Poe, in the same essay I quoted, "The Domain of Arnheim," develops a theory that might at first seem to disagree with the location selected for the house: "The taste of all the architects I have ever known leads them, for the sake of 'prospect,' to put up buildings on hill-tops. The error is obvious. Grandeur in any of its moods fatigues, depresses. For the occasional scene nothing can be better, for the constant view nothing worse. And, in the constant view, the most objectionable phase of grandeur is that of extent; the worst phase of extent, that of dis-

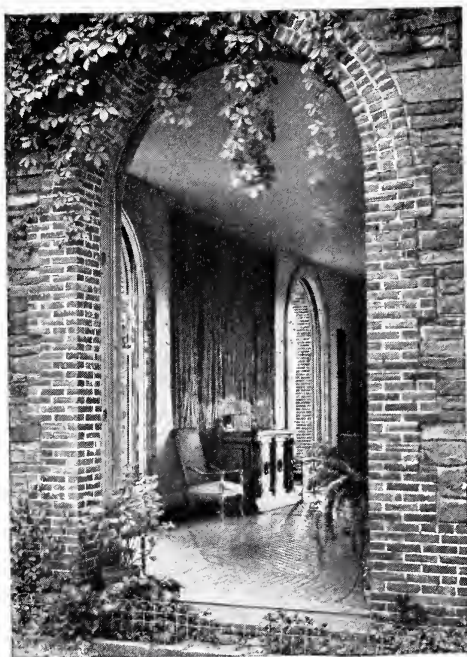

THE LIVING ROOM FROM THE FORECOURT.  
(Point of View 4 on Plan.)

tañce. It is at war with the sentiment and with the sense of *seclusion*—the sentiment and sense which we seek to humor in ‘retiring to the country.’”

The latter part of the passage will explain why, while agreeing with these principles, I did not feel that the location was condemned by the first part. There is a vista, from the entrance and from the principal rooms of this house. However, this vista is naturally such as not to give the feeling of being lost in space, as does an extended view. The photographs can hardly show the converging lines of the valley, forming a sort of wooded amphitheatre with a narrow opening in the main axis toward the bluish line of a more distant hill. There is the same feeling of seclusion from the world as is given by the main perspective in the Villa d'Este, framed by high trees, and leading the eye to one focus, instead of offering too many subjects to the observer. And it is this division of interest that causes fatigue, much more than mere distance. By eliminating it, or by selecting a natural site

free from it, the impression of calm is at once restored.

The illustrations accompanying these notes, and the plan showing the points where they were taken, would make any comments superfluous, were it not for the fact that there are two groups of buildings that no photographic reproduction has ever adequately succeeded in representing. They are those buildings in which color plays an important part, and those that derive their merit from successful proportions more than from decorative details. This house belongs to both.

Of a very moderate size, it gives, however, a feeling of spaciousness quite remarkable; and this is due, above all, to a most careful study of the proportion of the rooms. All mouldings, ornaments, recesses, all those things that are commonly called “architectural trimmings,” have been eliminated. The authors of an excellent book on interior decoration have written: “Proportion is the good-breeding of architecture.” Here is indeed an example of that “noblesse,” that distinctive elegance achieved only by a highly developed culture.

And when I speak of proportion, I have not in mind those tabulated recipes of a Vignola. The only use of classical forms is the Palladian motive in the entrance hall. In the rooms, the walls rise without a break from the floor to the smooth ceiling. Outside, the masonry, with its vari-colored stone, enhanced by lines of brick, is the only decoration; but the fine outline of the roof crowns the whole building and gives to it a dignity which takes us far from the involved tricks of suburban country houses.

These walls, built shortly before the war, seem to be old. A careful selection of their material (an old quarry was reopened to secure it) and a still more interesting workmanship have contributed to this result. As I noted before, the house and its garden seem to have been always there. I have no doubt that the owner had from the very first month of occupancy this same feeling. And yet a remarkable fact is that the house is quite free from imitation of historic precedents





THE ENTRANCE AND TOWER FROM THE GATE OF THE UPPER TERRACE  
(POINT OF VIEW 5 ON PLAN)—RESIDENCE OF GEORGE HOWE, ESQ.,  
CHESTNUT HILL, PHILADELPHIA. MELLOR, MEIGS & HOWE, ARCHITECTS.





THE ENTRANCE DOOR FROM THE FORECOURT (POINT OF VIEW  
6 ON PLAN)—RESIDENCE OF GEORGE HOWE, ESQ., CHESTNUT  
HILL, PHILADELPHIA. MELLOR, MEIGS & HOWE, ARCHITECTS.





THE STAIR HALL FROM THE ENTRANCE DOOR (POINT OF VIEW 7 ON PLAN)—RESIDENCE OF GEORGE HOWE, ESQ., CHESTNUT HILL, PHILADELPHIA. MELLOR, MEIGS & HOWE, ARCHITECTS.





THE STAIR HALL LOOKING TOWARD THE ENTRANCE (POINT OF VIEW 8 ON PLAN)—RESIDENCE OF GEORGE HOWE, ESQ., CHESTNUT HILL, PHILADELPHIA. MELLOR, MEIGS & HOWE, ARCHITECTS.





THE LIVING ROOM LOOKING TOWARD FORECOURT (POINT OF VIEW 9 ON PLAN)—RESIDENCE OF GEORGE HOWE, ESQ., CHESTNUT HILL, PHILADELPHIA. MELLOR, MEIGS & HOWE, ARCHITECTS.





A DETAIL OF THE LIVING ROOM FIREPLACE (POINT OF VIEW 10 ON PLAN)—RESIDENCE OF GEORGE HOWE, ESQ., CHESTNUT HILL, PHILADELPHIA. MELLOR, MEIGS & HOWE, ARCHITECTS.





A DETAIL OF THE LIVING ROOM (POINT OF VIEW II ON PLAN)—RESIDENCE OF GEORGE HOWE, ESQ., CHESTNUT HILL, PHILADELPHIA. MELLOR, MEIGS & HOWE, ARCHITECTS.



THE DINING ROOM (POINT OF VIEW 12 ON PLAN)—  
RESIDENCE OF GEORGE HOWE, ESQ., CHESTNUT HILL,  
PHILADELPHIA. MELLOR, MEIGS & HOWE, ARCHITECTS.





THE STUDY—RESIDENCE OF GEORGE HOWE, ESQ., CHESTNUT HILL, PHILADELPHIA.  
Mellor, Meigs & Howe, Architects.

in its details. Were not the phrase "modern art" somewhat discredited for having been a cloak to a multitude of sins, I would see here a very typical example of what modern art ought to be: a logical continuation of the best traditions. It is as free from archaeological imitation as it is devoid of a pretentious striving for originality. There again the good-breeding asserts itself.

As someone who had recently visited it told me: "It does not look like a Philadelphia house." It is a distinct departure from the usual types—some of them of great merit—which for the last twenty years have been the fashion in the neighborhood. In few words, it has personality. Look at the very bold treatment of iron balconies on the garden façade; at the most ingenious arrangement of the stairway; and note the omission of those well known details which come at their assigned place, like certain rhymes in amateurish poetry. Everywhere one finds an expression of forms that seem to have

been created for that particular place, and without effort.

No doubt many clients would be disappointed by their inability to tack a "style" label to any portion of it. This consideration had no weight in the case, for, as I have said, the architect is also the owner. The living room is neither Elizabethan nor Jacobean; the dining room is not Louis XVI. They are both designed with a true sense of the decorative effect produced by the nature of the floor, the color and texture of the walls, and, above all, by their proportion. They attempt to be nothing more than a setting for the furniture, some tapestries and a few paintings, and with the true conception of a setting—that it must be nothing but a background for the players. There are interiors, of course, not complying with this rule, which are masterpieces. Bare of furniture, the rooms of the Doges' Palace or the "Grands Apartements" of Versailles are still beautiful. They belong, however, to that kind of



THE LOWER GARDEN AND HILLS FROM THE STAIR HALL (POINT OF VIEW 13 ON PLAN)—RESIDENCE OF GEORGE HOWE, ESQ., CHESTNUT HILL, PHILADELPHIA. MELLOR, MEIGS & HOWE, ARCHITECTS.



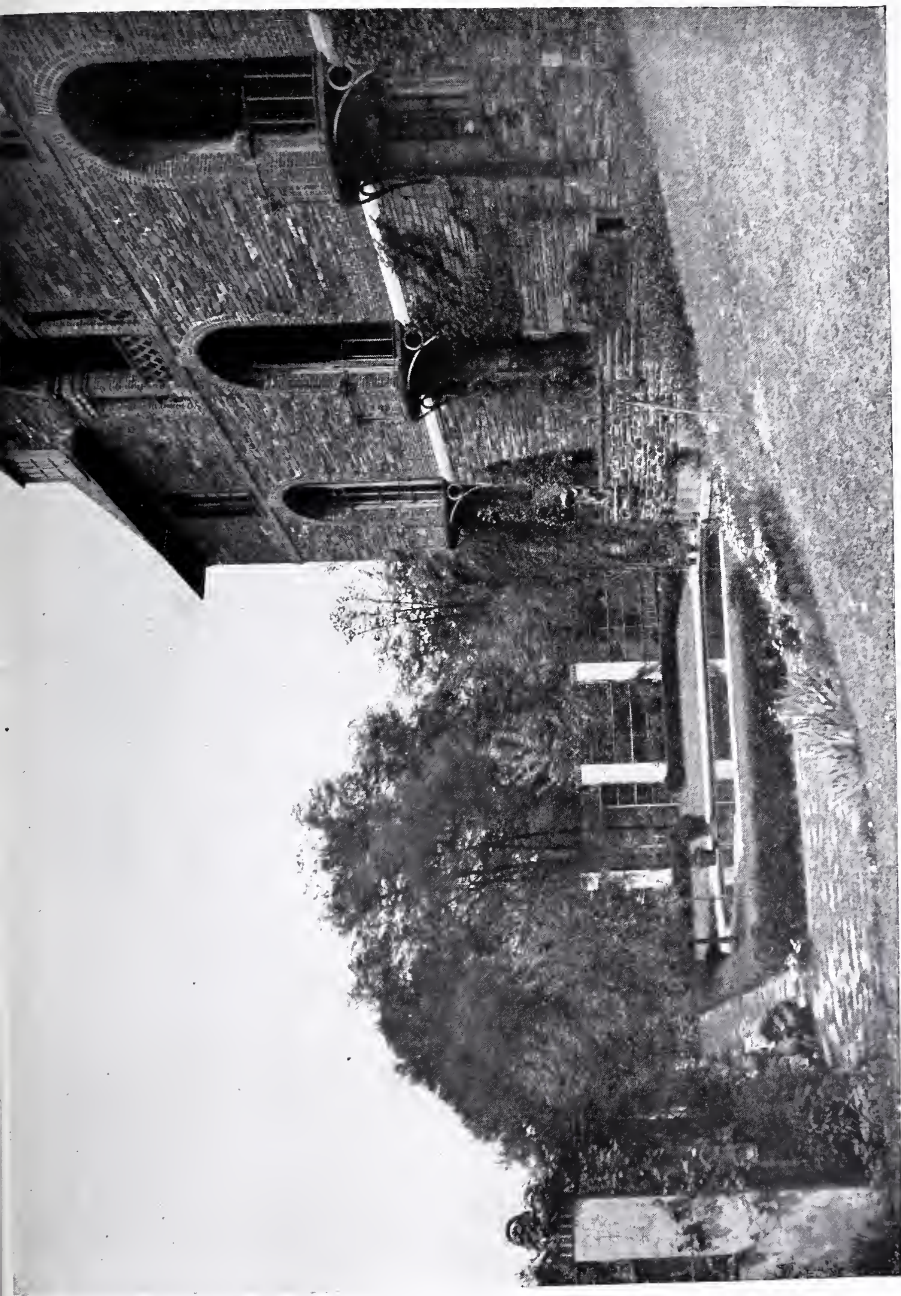

THE HOUSE FROM BELOW THE TERRACE (POINT OF VIEW 14 ON PLAN)—RESIDENCE OF GEORGE HOWE, ESC., CHESTNUT HILL, PHILADELPHIA. MELLOR, MEIGS & HOWE, ARCHITECTS.



THE HOUSE FROM THE LOWER TERRACE  
(POINT OF VIEW 15 ON PLAN)—RESIDENCE OF  
GEORGE HOWE, ESQ., CHESTNUT HILL, PHILA-  
DELPHIA. MELLOR, MEIGS & HOWE, ARCHITECTS.





THE HOUSE AND THE UPPER TERRACE (POINT OF VIEW 16 ON PLAN)—RESIDENCE OF GEORGE HOWE, ESQ., CHESTNUT HILL, PHILADELPHIA. MELLOR, MEIGS & HOWE, ARCHITECTS.



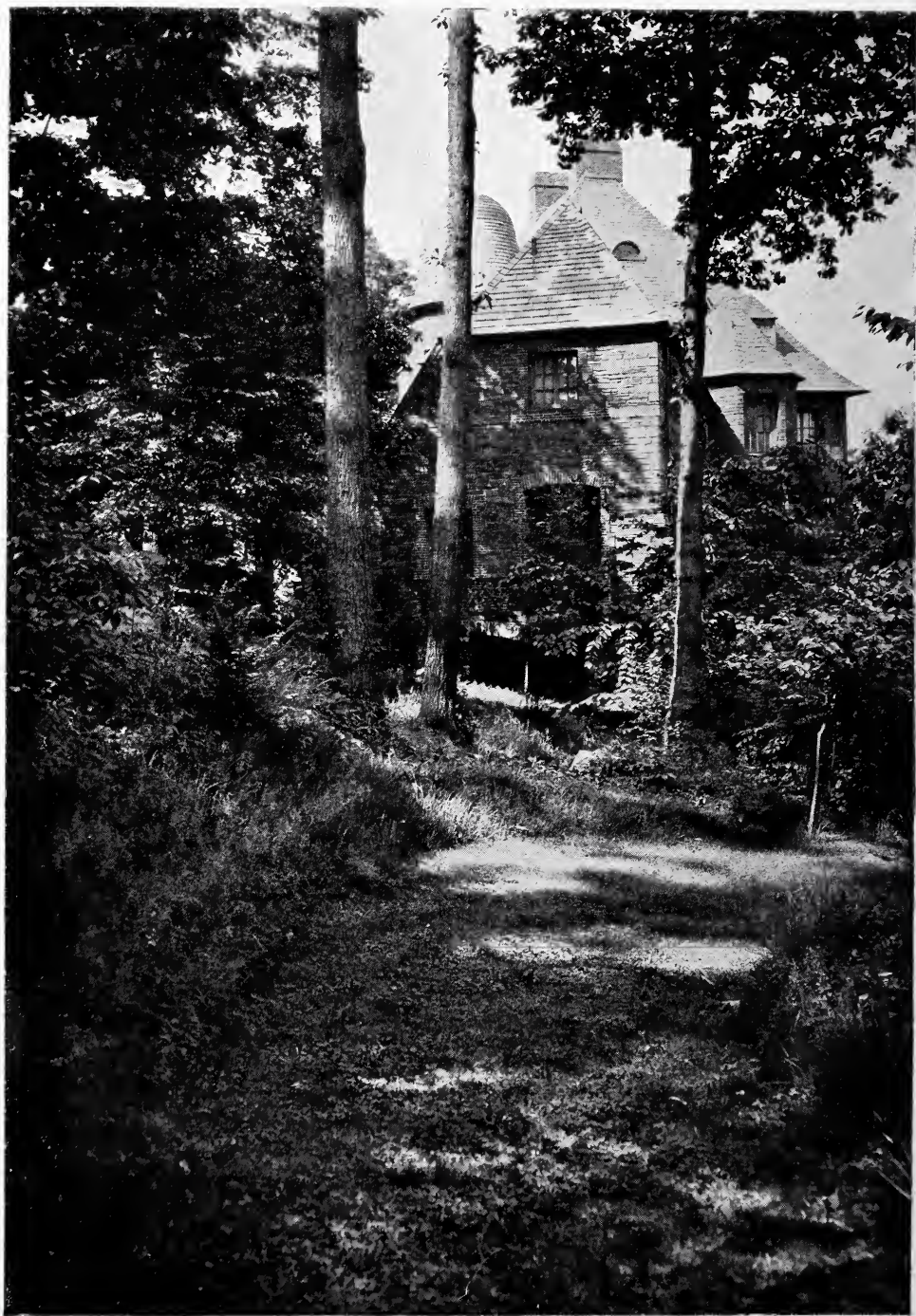

THE HOUSE FROM THE GREEN WALK (POINT OF VIEW 17 ON PLAN)—RESIDENCE OF GEORGE HOWE, ESQ., CHESTNUT HILL, PHILADELPHIA. MELLOR, MEIGS & HOWE, ARCHITECTS.





THE SERVICE WING (POINT OF VIEW 18 ON PLAN)—  
RESIDENCE OF GEORGE HOWE, ESQ., CHESTNUT HILL,  
PHILADELPHIA. MELLOR, MEIGS & HOWE, ARCHITECTS.



THE VIEW FROM THE UPPER TERRACE.  
(Point of View 19 on Plan.)

stately rooms which have an entirely different function from those in a moderate sized house; besides, they were intended to receive a very small amount of furniture, as we learn from the contemporary engravings. For a different program must be found a different solution, and we find here a new proof of the unerring artistic sense of Messrs. Mellor, Meigs and Howe. They have resisted the temptation to design an interior like an exterior elevation, which has to stand on its own merits or with the scant assistance of planting at its base.

There is much to say on the skill shown in the placing of furniture and hangings in the rooms. This furniture, collected by the owner with the same good taste characterizing his professional work, has been used in the composition of the rooms exactly as any integral part of the building. It is not often that the architect has this opportunity, in spite of the fact that he is better prepared than anybody to do it. The grouping of seats around

a cabinet, the placing of a bronze or marble of the right size and color over this cabinet, the selection of the tapestry that will set off the whole, the right height for the hanging of a painting in a panel, all this is designing with various elements and requires an eye trained to the sense of proportion, the combination of color, and the juxtaposition of volumes, that is to say, the esthetic part of architectural studies. It does not imply that the architect has necessarily to be the adviser in the selection of the pieces of furniture that he may be called upon to place in the rooms. He may advise on the best grouping of elements already belonging to his client in the same way that the landscape architect makes use of the natural conditions of a site and of shrubs which are not made to order but grown in nurseries.

As noted above, an important element of the work of Messrs. Mellor, Meigs and Howe is the color. Its value is entirely lost in photographs. On the exterior, the vari-colored stone work to which I have referred, enhanced by its lines of brick, is composed of natural seam-faced stones of dark buff, brown and reddish hues. The woodwork is of a dull blue. The combination has the merit of having a value approximating the deep green of the trees around, and thus preventing the house from "standing out" from its background too sharply.

Inside, the scheme selected is no less remarkable. The key for the living room was given by the fine tapestries hanging on the walls. The floor is made of Enfield tiles of a grayish yellow with borders of a dull blue. These same blue tiles turn around the windows and the fireplace; the ceiling and walls are painted a gray-yellow, which sets off the old pieces of furniture. The entrance hall has been composed around the vista seen between the columns when one enters the front door. Everything was then subordinated to this neutral note of color. A pavement of black and white marble and the gray-buff walls form an appropriate frame to enhance the distant landscape, in the way that a cardboard mount strengthens the delicate tone of a water color.

The dining room was evidently de-





THE VIEW FROM THE LIVING ROOM.  
(Point of View 20 on Plan.)

signed for a painted frieze of the seventeenth century, faded like an old pastel, that occupies the upper part of the walls, which are divided in very simple panels and painted an ivory tone. Around the fireplace a border of Italian tiles, with yellow and blue ornaments on a white background, is the only other note of color. The floor is made of marble tiles. In the oval room, a most ingenious scheme was used for the floor. A rough cement, stained with oil, becomes interesting by the contrast of a border of green tiles surrounding four medallions of Enfield mosaics of a wonderful color and design. This very new and appropriate treatment has great possibilities and opens a large field for the use of this material.

One can judge by these four very different treatments of the pavement of the care given to every detail of the whole. These floors may seem to the reader to have received an elaboration and a quality of material out of keeping with the wall treatment, but again I find that the archi-

itects are right in spite of the usual practice. When we enter a room, or stay in it, our field of vision, unless we make a special point of studying the architectural treatment, grasps the furniture nearest to us, a small portion of the lower part of the walls, and a large expanse of floor. When the floor is an uninteresting area of hardwood, or a plain carpet, we feel the necessity of relieving it by placing here and there the rich color and pattern of Oriental rugs. This is somewhat of a makeshift, for the rugs seldom agree either in character or color with the rest of the decoration, which is thus thrown out of balance. One can easily see the advantage of using a pavement designed for the room. It is not an extravagance, as might be objected, if one considers the cost of fine rugs, and it adds a sort of substantiality to the general treatment that carpets or rugs are unable to supply.

The photographs illustrating these notes have been selected by the architects with two ends in view. One is to secure a logical presentation of their work, in the sequence that the visitor of the house is most likely to follow. By reference to the plan, it is always easy to understand what is shown in the picture and to gain a complete understanding of the arrangements. The other aim is to show only those pictures that give the true aspect of the house and grounds, that is, to eliminate views taken from distant stations, or pictures showing aspects that the visitor does not really perceive. The optic angle of a camera is quite different from our field of vision; the result is that many photographs show much more than we can really see at one glance. By limiting the field covered by a picture, the result approximates much more closely the real impression received by a visitor. It is hoped that the very complete set given here will allow a fair study of this hillside house.

It is a study well worth the time given to it. I will, for instance, point

out in the general layout, besides the complete adaptation of the plan to natural conditions that was mentioned above, the very interesting solution of the division of spaces. It is not simply a pleasant combination of garden-architecture forms; it has also the quality of the well-planned industrial plant where each process of fabrication is in the right relation to the preceding and succeeding processes. There are some spaces for sitting (the upper terrace and the lower garden); spaces for walking (the green walk, the pleached walk); spaces for working; and each of these in the proper place and with the special character it deserves. The terrace, for instance, is the logical extension outdoors of the living room. The green walk takes one through ever-changing aspects.

The greatest pleasure will be found in discovering in these features, which at first seem to have been adopted without thought, a clever adaptation of the great principles of design; in realizing that this architecture, which owes so little to precedents, is true to the best traditions of art; in finding the soul of our art instead of the cast-off clothing of former time.

It would be an interesting study to analyze the methods by which the archi-

itects secure in modern work the charm of these old European country houses, so unpretentious that they seem without architectural merit to the casual observer, even though he be impressed by a peculiar quality not found in more elaborate buildings. Superficial students dismiss the whole question by ascribing this subtle quality they cannot otherwise explain to the fact that the buildings are old. Age has indeed a mellowing influence on buildings which cannot be overestimated. It gives the roofs those undulating surfaces which blend their lines with those of the distant hills. It stains the walls and clothes them with ivy. It brings additions and alterations to the original scheme that are a new and unexpected note. It is not, however, the sole cause that makes the tourist deem worthy of a snapshot a farm courtyard and its rambling buildings, a manor in Normandy or a peasant's house in an Italian village. There are other reasons, and in their research Messrs. Mellor, Meigs and Howe have gone much further than most of the men I know. It is to be hoped that they will some time make the result of their studies available not only by its application to such work as the hillside house here illustrated, but in a didactic form, for the benefit of the profession.



# The CORTILE OF THE PALAZZO PERETTI IN ROME



BY



HAROLD DONALDSON EBERLEIN

*Drawings by R. M. Kennedy, Fellow in Architecture  
American Academy in Rome*

IT once so happened that the Holy Father—which one it matters not, and the writer does not remember—was giving audience to three foreign clerics. Of the first his Holiness enquired, "How long have you been in Rome?" To which the priest replied, "Six days." "Ah, you have seen Rome," said the Pope. Next, of the second ecclesiastic he asked, "And how long have you been in Rome?" "Six weeks," came the response. "Then you are seeing Rome," was the Pope's comment. Finally, of the third he asked the same question as of the two preceding. "Six years," replied the monsignor to whom the query was addressed. "You will never see Rome," rejoined the Holy Father.

Whether apocryphal or not, this anecdote emphasizes tersely the impossibility of ever fully knowing Rome. Any observant person who has lived there, even for a very short time, is aware of the utter futility of expecting to know, or see, or understand all that Rome contains. The Eternal City is an inexhaustible treasure house full of varied riches, for the examination of which the span of no single life could ever suffice. Even the prying, grubbing, industrious, tabulating Mr. Baedeker has barely scratched the surface of Rome's possibilities.

The most that one not living for a long period in Rome can hope to do, apart from gaining a reasonable acquaintance with the greater monuments, is to discover for himself some of the lesser treasures that have been shouldered aside by the multitude of more imposing

works, and well nigh forgotten or completely ignored because of their comparative obscurity, although in other places less richly endowed with masterpieces of all the arts their worth would be loudly acclaimed.

One of these many unsung bits of "unknown Rome" is the cortile of the Palazzo Peretti, an old house, numbered 7 in the Via Parione, and not far from the church of Santa Maria della Pace. Letarouilly knew the house to some extent, for he has given the doorway, the vestibule, and the decorations in the vaulting of the vestibule—decorations that have been attributed by some to Baldassare Peruzzi, by others to Giovanni da Udine. But he has not given nor mentioned the cortile, which is at the first floor level and not on the ground floor as is the usual custom, very possibly because he did not know of its existence, for it is so well concealed from view that no one would be likely to suspect its presence unless well acquainted with the penetralia of the palazzo. The only access is from the rear of the first floor apartments, and one could go casually in and out of those apartments a hundred times without being aware of the cortile.

Letarouilly speaks highly of the house, so far as he knows it, and vouchsafes this much information—that it is often called the house of Sixtus V, and adds that the legend beneath an old view of the house states that it was for some time occupied by Sixtus V while he was still Cardinal Peretti. Now what we know further is this, that the *archivio notarile* of the Apostolic Chamber con-

tains a document concerning the sale of the house, the deed of sale being dated February 11, 1574, and shows that the buyer, one Andrea Rubini, purchased it for 2,050 scudi, "pro persona nominanda." Another document, of April 2, 1574, declares the "persona nominanda" to have been Cardinal Felice Peretti, and there are many evidences to prove that he lived here between 1574 and 1581 or 1582, when he retired to his little villa and *vigna*, near Santa Maria Maggiore, where he lived in comparative seclusion till his elevation to the Papal Throne in 1585.

It was presumably from this very house that the Cardinal's nephew, the unfortunate Francesco Peretti, was treacherously enticed one evening and assassinated at the instance of Paolo Giordano Orsini, Duke of Bracciano, because that puissant nobleman was enamored of Francesco Peretti's wife, the beautiful Vittoria Accoramboni—a passion apparently reciprocated by that ambitious lady—and wished to have her for himself. This tragedy nearly broke the Cardinal's heart, and for solace drove him more closely than ever to his three hobbies: books, the arts and building, to which he had devoted himself during the period of his political eclipse, since the elevation of Cardinal Boncompagni to the pontificate as Gregory XIII.

Save the facts just noted with reference to the history of the Palazzo Peretti, all else is conjectural owing to the present lack of documentary evidence; but it was presumably during these years of comparative quiet, leisure, and such architectural activity as his relatively slender means would permit, that, with his passion for building, he caused the cortile to be constructed. The structural evidence points to about 1580 as an approximate date.

It has been suggested, on the strength of sundry items of design, that either Giovanni da Bologna or Bartolommeo Ammanato may have been responsible for the plan. But Giovanni da Bologna, so far as we know, was working in Florence about the time the cortile was apparently constructed and had been for some years previously. Bartolommeo

Ammanato, too, he who rebuilt the wondrously beautiful Ponte alla Santa Trinità across the Arno, seems to have been steadily employed in Florence during all this period, although the general flattening out of the projections in the cortile, compared with the usual bold and swelling relief that was becoming more and more characteristic of baroque design, would favor the hypothesis of an architect accustomed to the Florentine repression of any tumultuous abandon of lines.

It seems much more likely that the work, which is obviously not the product of one who had already become a great master, whatever budding promise of genius he might have disclosed, was the creation of Domenico Fontana, a young architect who had recently come to Rome and whom Cardinal Peretti had employed on the little villa to which he afterwards removed, the same Domenico Fontana who later constructed the fountain of Acqua Felice and carried out so many of the projects that marked the reign of Peretti when he had become Pope Sixtus V.

Fascinating and full of suggestion as it is, the composition is scarcely mature enough in conception to have been wrought by an architect of Giovanni da Bologna's or Ammanato's experience. It seems rather to point to a clever young architect trying his wings, not yet quite sure of himself and not yet displaying the sense of elimination and of self-control that later years would bring, but showering us with the exuberant fruits of an ardent and spontaneous invention from which we may pick many a delightful detail and gather not a little inspiration.

As a study in the combination of architecture and painting it is at least interesting, if not indeed distinctly illuminating and suggestive. It might have been equally engaging as a study in the combination of architecture, painting and sculpture, if the niches, on each of the three sides, now contained the statues for which they were in all probability originally designed. As will be seen by reference to the elevation drawing of the end or south wall, the mouldings, cor-



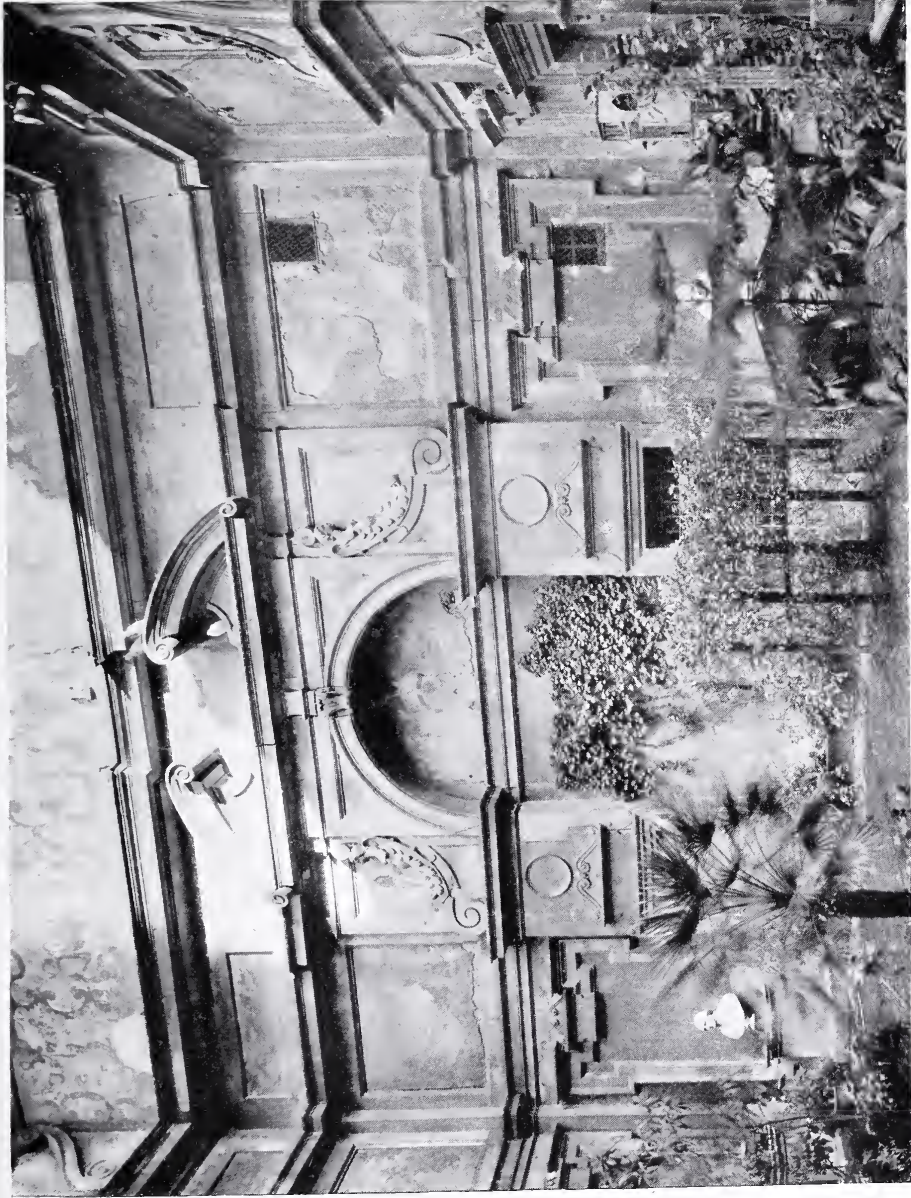

SOUTH WALL - CORTILE OF  
THE PALAZZO FERETTI, ROME,

nices, pediments and other carved work are of white marble, now stained a rich brown by action of time and weather; that the flat surfaces of the panels and frieze are of plaster; while the upper cornice between the interrupted pediments and the frieze, and also the top-most cornice beneath the eaves, are of stucco. Much of the color in the frescoes, though not all, is sadly dulled or even obliterated; windows from the house beyond have been cut through several panels, and against others pigeon boxes have been nailed; the whole aspect is one of deplorable squalor. Nevertheless, though the cortile may have lost its brilliance and glory, it retains a substantial residuum of its pristine dignity.

Doubtless some, upon contemplating this cortile, will say, "Interesting, but decadent." To which one might make the rejoinder, "What is decadence?" "A falling away; incipient or partially advanced decay; deterioration," and so on, may do all very well for a dictionary definition, but, in a case like this, it begs the question of relative values and a standard of comparison. What is to be the standard of comparison, and who is to determine it? After all, is it not largely a matter of personal taste and judgment, and, under such circumstances, who is to be the final arbiter? One person, upon being confronted with a well matured piece of *brie* cheese, sniffs at it, will have none of it, and declares it "decadent," only he will probably use a shorter and less polite word. Another will eat the cheese with relish and opine that it is just becoming properly ripe. In this case "decadence" is clearly a matter of personal taste, of personal point of view, and depends upon what the state of the individual's gustatory education and propensities may be.

In the same way, with reference to architecture or any other branch of art, for that matter, the existence of decadence, or its degree if present, will be judged according to the individual's previous education and mental background and the attitude thereby engendered. If he be constitutionally a purist, endowed with a puritan type of mind, he will seek satisfaction for his conscience and for his

inelastic outlook by an unyielding insistence upon what he conceives to be the standards hallmarked by convention.

Taste, decadent or correct as we may individually deem it, is in great measure a matter of purely personal preference, and either decadence or impeccable purity can be rightly gauged only by considering (1) the psychological forces prompting the several modes of expression, and (2) the measure in which the modes of expression satisfy the requirements imposed by those varied forces.

Examining the cortile of the Palazzo Peretti from a rigid purist's point of view, there are sundry features of the design, quite apart from the general conception, that one would probably pick out as flaws and signs of decadence. To instance a few of them: There is the increasing weight of scale from the base upwards without any compensating balance at the bottom. There is the multiplicity of cornices. There are the frequent breaks in the cornices, and especially the short breaks above the pediments. There is the whimsical form of the niches, in the lower stage on each side, where a structural principle is reversed by the angular jogs, thus giving to a void instead of to a solid a stepped pyramidal form. There is the equally whimsical dog-eared framing of the lower panels, where the head of the framing is deliberately interrupted and dropped down for the purpose of squeezing in irrelevant ornament. There are the scrolled and interrupted pediments, a form in itself abhorrent to many, and here existing solely for decoration. There are the attenuated proportions at the spring of the arches, a fault visually accentuated by the disposition of the mouldings. Besides all of which, there is the fact that every bit of the architecture is palpably employed for decorative effect alone, and that the whole composition is overwrought to satiety by a complex display of "architectural jewelry."

But the application of purely abstract architectural logic may betray us into a false position. Before meting out the censure of academic logic to the cortile of the Palazzo Peretti, let us consider





SOUTHEAST ANGLE—CORTILE OF  
THE PALAZZO PERETTI, ROME.





EAST WALL—CORTILE OF THE  
PALAZZO PERETTI, ROME.





WEST WALL—CORTILE OF THE  
PALAZZO PERETTI, ROME.



SECTION OF EAST WALL—CORTILE  
OF THE PALAZZO PERETTI, ROME.





DETAIL OF WEST WALL—CORTILE  
OF THE PALAZZO PERETTI, ROME.



DETAIL OF SOUTH WALL—CORTILE  
OF THE PALAZZO PERETTI, ROME.



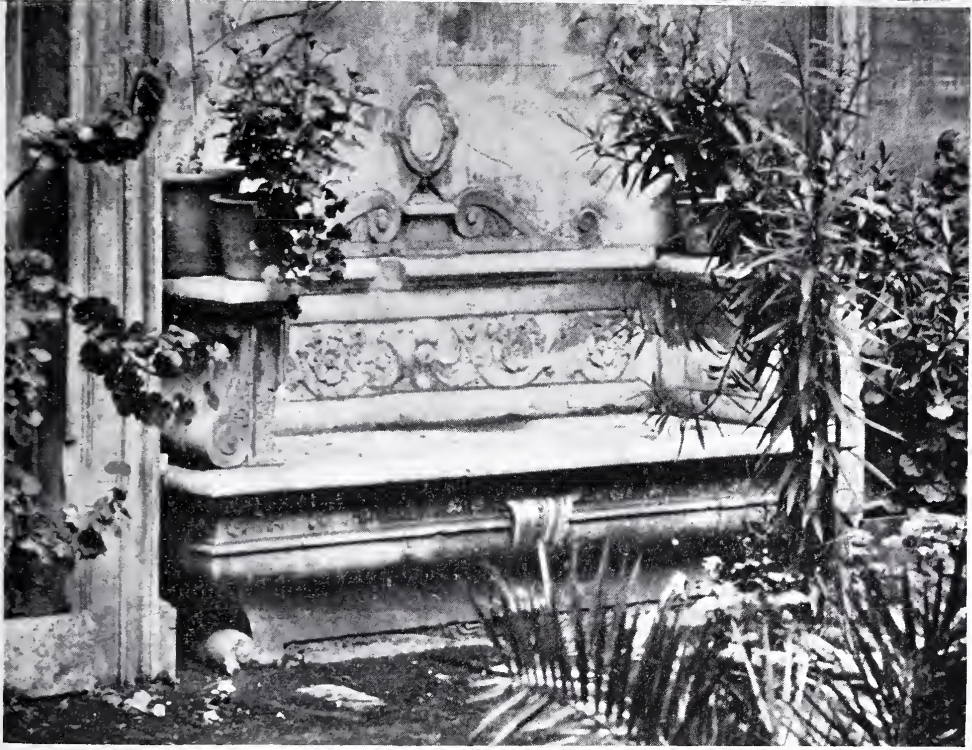

SEAT IN EAST WALL—CORTILE OF  
THE PALAZZO PERETTI, ROME.

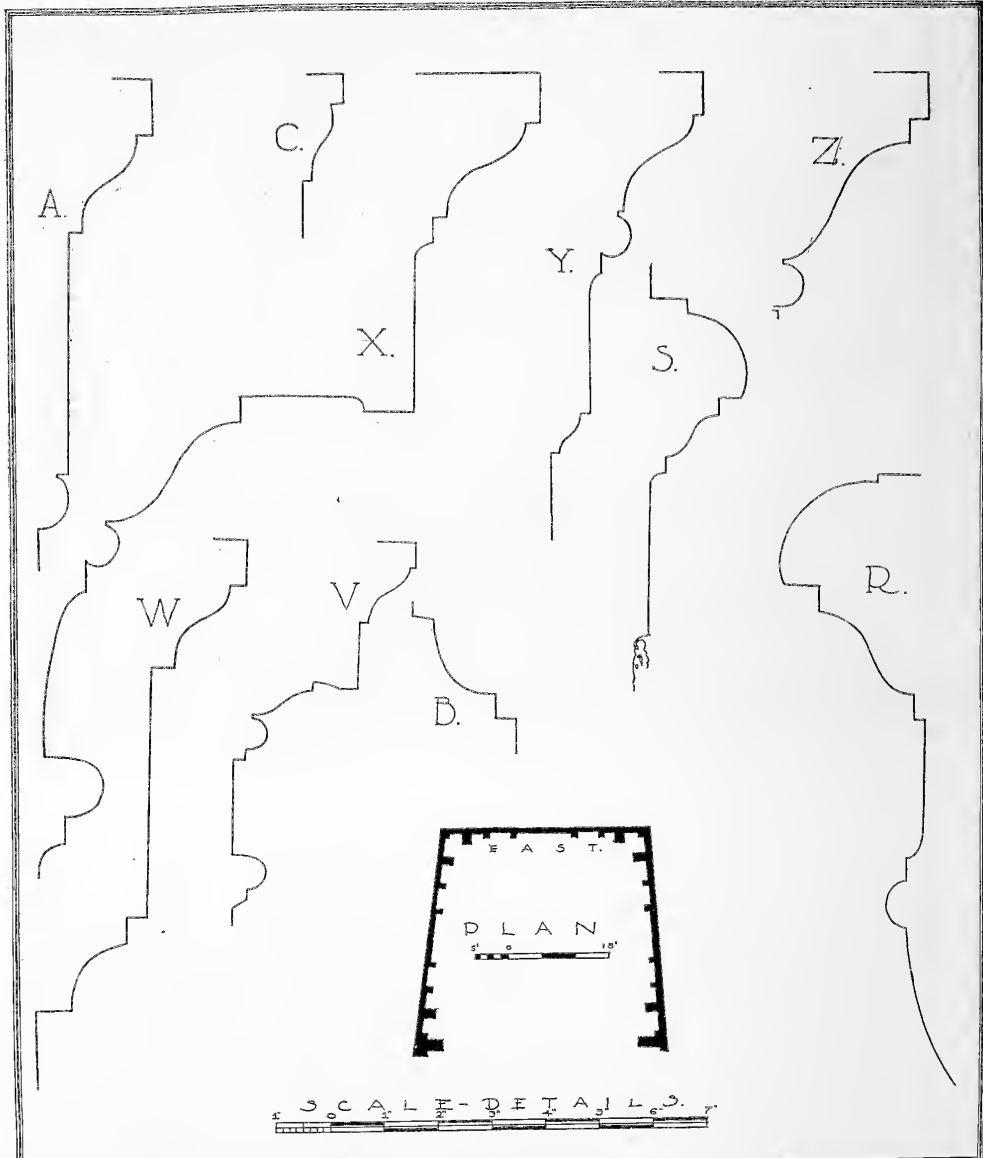

DERETTI DALACE  
 ROOM  
 PLAN AND MOULDINGS.



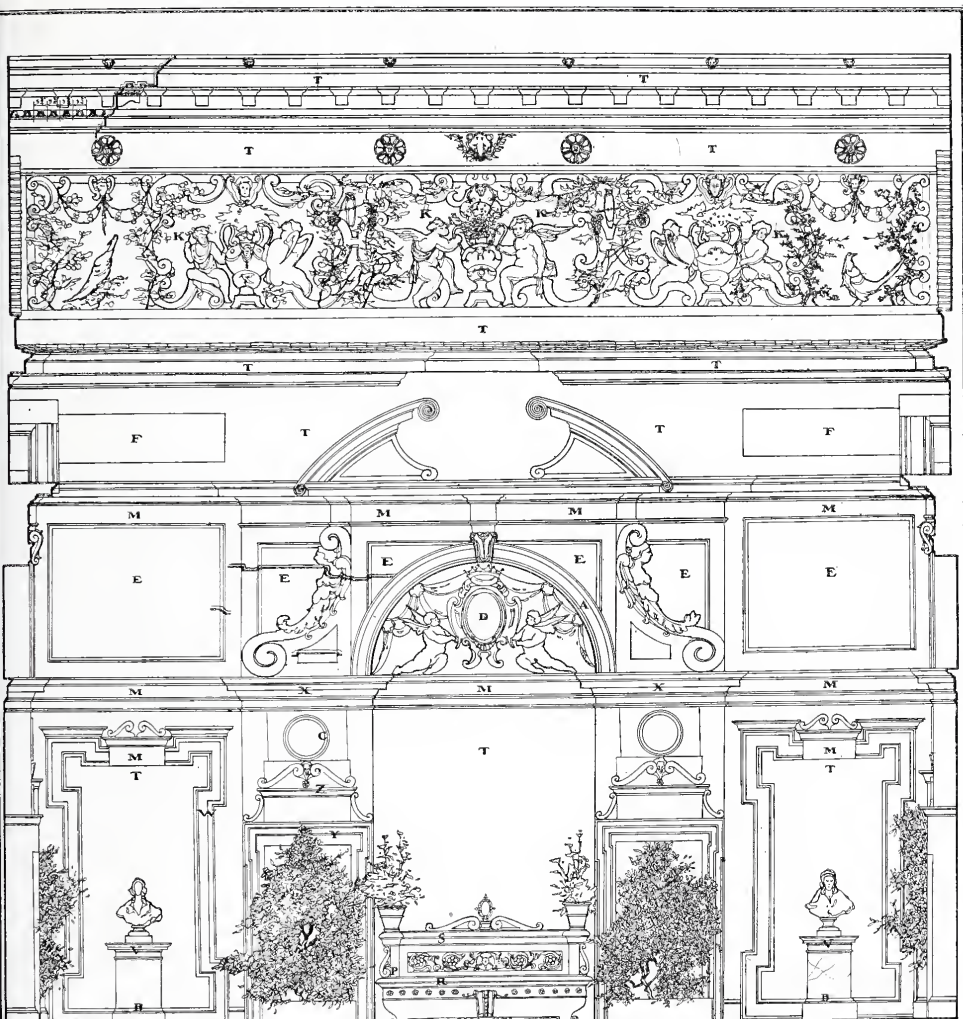

# PERETTI PALACE ROME

EAST SIDE OF COURTYARD

K FRESKOED FRIEZE IN BLUE AND GOLD. F FRESKOED DANNELS IN GOLDEN BROWN. E FRESKOED LANDSCAPES. D GOLD CARTOUCHE ON RED GROVND. T STVCCO. M MARBLE

what it really is. There is no inherent need of any architecture at all; nor was any need ever pretended. The whole composition is an architectural *fantasie*—architecture at play—contrived solely to enliven what would otherwise have been a dull and depressing open space between three blank walls. Now, it is of the essence of fun and play to be absurd, illogical, to set at naught the force of gravitation, to defy the sober conventions of mechanical logic, to play tricks, to stand on one's head or walk on one's hands. The architect of the cortile clearly perceived the nature of the situation, and he grasped the potential gaiety in it. Why should he not give voids the form properly belonging to solids? Why should he not drop out the heads of the panel frames and pile atop the dropping central block a couple of ridiculous scroll-lets butting their heads together?

He was called upon to create architecture for amusement, for effect, for delight, without any feeling back of it of structural responsibility. And this he did without fear, without stiffness, and also without any vulgarity or coarse horse-play. It was plainly a case in which, as was the wont with Renaissance tradition, imagination came first; and it was right that it should. But while yield-

ing himself to the impulse of imagination, he did not forget architectural good manners, for he was punctiliously careful of his symmetrical arrangement. Nor did he forget the necessities of visual satisfaction, for he deliberately multiplied and emphasized his horizontals to keep down the apparent height of what would otherwise have seemed a well. In following Renaissance instinct and aiming at effect, he considered carefully both the purpose of his work and the point from which it would be viewed and then let himself loose.

An immediately practicable and concrete suggestion afforded by the cortile is this. The prospect from any high building in any of our cities is blemished by numerous blank, ugly open spaces between enclosing walls, spaces into which human eyes must look many times a day. The architectural enlivenment of such wastes in a manner comparable to the treatment in the cortile of the Palazzo Peretti would, to put it mildly, be a work of civilization. So far as the specific architecture of the cortile is concerned, it supplies us with not a few details of exquisite delicacy, and its general blitheness somehow tempts one to say, "Better be decadent and interesting than impeccably correct and logical, and stupid."



# Garden Apartments in Cities



By John Taylor Boyd, Jr.

## Part II (Conclusion)

THE preceding article outlined the development of the garden apartment in New York City. Since this subject of city housing is a complicated one indeed, only certain essentials of it could be touched on. These were the factors of design, finance, management, and the legal aspects of sanitation and public welfare in their relationship one to another, together with some possibilities of their influence on the future. The actual character of the garden apartment itself, particularly its design and its various types, was left to be considered in this paper.

As to the types of garden apartments, it is well to remember that city housing deals with a multitude of conditions. In order to appreciate these better, and without attempting any scientific classification, one may describe three classes, basing distinctions on the scale of rentals. First, and forming the largest class, are the apartments for the wage earners, the class which is lowest in the scale of rentals; second, and not so extensive, is the housing for the economic class, just above the wage earners, chiefly the salaried workers; and, third, are the more spacious and luxurious apartments of wealthier citizens.

Of these three classes, the housing for the wage earners is by far the most important, for two reasons. As noted above, it forms the bulk of a city's housing, and it is the most difficult to provide at rentals that can be paid out of wage scales. In fact, this relation of rental cost to wage scales is really the crux of the housing difficulty of the day. In a sense, the "housing problem" is not properly a housing problem at all, but concerns rather the economic life of the nation. It involves the establishing of wage scales that will allow wage earners to maintain

those reasonable standards of living which are necessary to good citizenship. Proper shelter is only a part of this reasonable standard of living.

Wage scales vary, of course, among wage earners, and at the top are the higher paid mechanics in factories, the skilled hand workers, and the clerical workers. The lower-paid workers, chiefly the unskilled, are really in a different economic situation and might even be said to form a fourth class in housing. They are obviously the most difficult class of all to house, and, in most American cities, masses of them still dwell in old, deteriorated buildings, which are rented to them at a figure that comes within their slender means. Until the wages of this class of workers can be raised to a point that will allow most of them to afford better housing, slums will continue to flourish. This condition may be stated in another way, by saying that there are many industries which are able to earn profits only by paying such low wages that their employees are forced to live in outworn buildings, or in buildings built for other purposes than housing, and which, in the process of growth of cities, have been abandoned to become slums. In reality a part of the capital of such industries is "invisible capital," belonging to undesirable landlords in the form of slums. This relationship of slums to certain industries in a city should always be kept in mind in planning any comprehensive schemes for city housing.

Another difficult factor in providing proper housing for wage earners is that building ordinances and standards of living decree that this low-rent housing shall be, in many essentials, of the same high class construction as the apartments for wealthier classes. In most cities first-class fire-resisting construction is re-

quired for all buildings in more congested areas, and in other outlying districts the requirements, while less severe, are no easier for one type of apartment than for another. And, at any rate, the best policy of finance and management, such as City and Suburban Homes Company and the Queensboro Corporation practise, demands only the soundest and most substantial building construction, otherwise a heavy loss occurs through depreciation. Also in the matter of mechanical features, such as plumbing, heating, wiring, etc., the same considerations dictate the highest standards. The Queensboro Corporation, which provides housing for the middle class, furnishes bathrooms of the same grade as those in luxurious apartments. In regard to interior finish, all three classes of New York apartments are much alike, since even in the highest priced apartments it is the custom to furnish the tenant with the plainest interiors and to allow him to install at his own expense whatever decorations he wishes.

Wherein, then, does the difference in relative cost of construction of the three classes of apartments lie? Principally in the sizes of rooms, decoration of entrances, vestibules, lobbies, corridors, etc., and in cost of materials of architectural design that may be used on the exteriors. The cheaper apartment houses may even be more expensive in one respect: suites in them occupy the least possible space, and kitchens and bathrooms occur more frequently in the plans. All these differences and resemblances are important, because they show that the business of providing proper housing at reasonable rentals in a large city is an extraordinarily difficult one. In some respects, at least, the standard is the same for the apartments of the mechanic as of the millionaire, and, as mentioned above, it should always be remembered that at the root of the whole complex situation are the wage scales, the standards of living, and the cost of living—the economics of the national life.

The foregoing paragraphs furnish some idea of the chief types of garden apartments. One more general fact

about them may be considered: this is how far is the garden apartment idea original to New York City? Replying to such a question, one may say that the several men who have developed this great conception have gone elsewhere to borrow elements and conceptions for their schemes; that they have independently invented other features that at the time they did not know had already been invented elsewhere, and that—here is the true conception of originality—they combined these various elements into a whole, consistent, almost new conception such as cannot be found perfected elsewhere to quite the same degree—to the same degree in American city housing at least. As to Europe, conditions are so different there, and Americans are so busy that they do not attempt to keep track of everything that happens abroad, so that the New York men prominent in this work are chary of expressing any opinion. Stated more specifically, the idea of apartments with much open land around them is not new. The heads of the Queensboro Corporation say that they were impressed with this fact, when, on a visit to Germany in 1914, they saw the new housing in apartments, with ample recreation space around them, built in the newer suburbs like Charlottenburg. The same is true of details of design. The idea of the court, of course, is as old as architecture. The "open stair" in apartments is a London device, and was found reproduced in a few cases in Brooklyn years ago. Mr. Thomas has developed the idea of using loggias, though this practice is many years old in Chicago. Planning apartments two rooms deep had long been a characteristic of apartments for the rich, though Mr. Thomas was one of the first to employ it in wage-earner's housing. Even that arrangement of plan, of having separate entrances for apartments and eliminating both public and private corridors—which Mr. Thomas has so well worked out in apartments—is old in college dormitories, going back even to the cloisters of Oxford, though naturally on account of the greater number of rooms and the kitchens, it is a



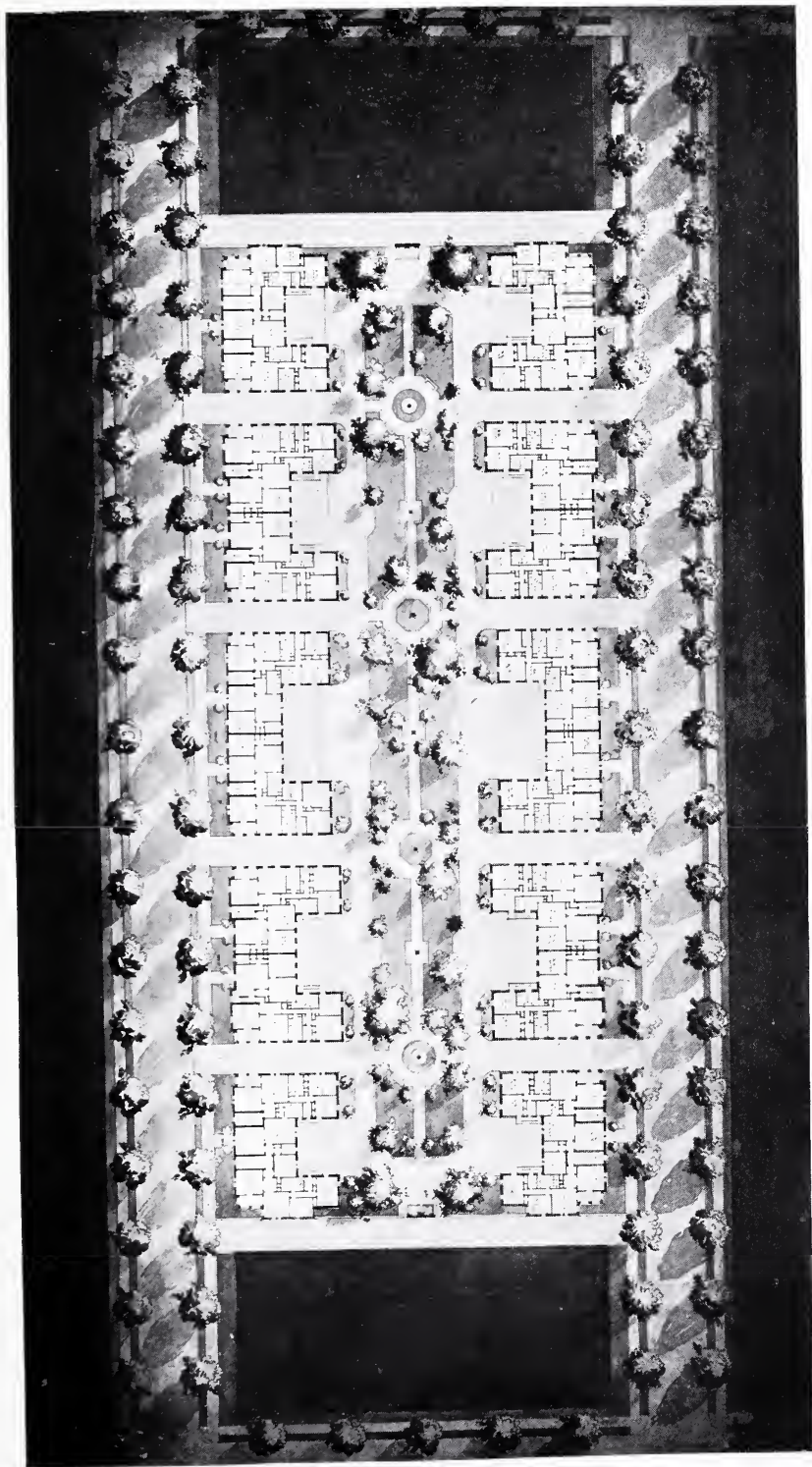

GROUP PLAN OF OPERATION NO. 8 OF THE QUEENSBORO CORPORATION, JACKSON HEIGHTS, BOROUGH OF QUEENS, NEW YORK CITY. ANDREW J. THOMAS, ARCHITECT.

much more difficult matter to introduce into apartments. Indeed, when I visited these apartments which Mr. Thomas designed for the City and Suburban Homes Company (illustrated in the previous article) and for the Queensboro Corporation, I could not help being struck with their resemblance to the typical group of American university dormitories arranged around a yard or campus. What are they but garden apartments! May not one ask the question now, is not this dormitory conception of our universities in some measure the goal which the garden apartment is approaching? If one ponders this comparison, one may conclude that if further progress in garden apartments is possible it is in just this respect. The only drawback that I could see in the apartments mentioned lay in somewhat imperfect shaping of the interior court of the groups, and in the fact that the architectural aspect of the rear of the apartments seen from the court, fine as it was, was not quite so good as the exterior. In the best college dormitories the court is the best part. Hence, where garden apartments are built under new conditions, where land can be obtained or controlled so that the expense of it is not so great as it is around New York, more land may be spared to obtain some such beautiful effect as that of the grouping of the old dormitories of the Harvard yard, which is so much admired. Whether this ideal could be reached in lowest rental apartment housing, particularly in a city like New York, is, of course, doubtful. But it seems surely possible in middle class housing, and some apartments of the better class in outskirts of cities have an arrangement similar to this one suggested. Such is the group of apartment houses at Lawrence Park, Bronxville, N. Y., designed by Bates & How. The group was begun several years ago and is not yet complete.

It is also a question whether the long, narrow shape of a city block, established by custom in New York, needs to be revised in order to allow the best design for garden apartments. To be sure, a

narrow court in itself is not poor architecture—a fact proved by the Vicars' Close, at Wells, England. But nevertheless the typical New York block shape was established in 1807 to provide for individual houses on 25 by 100-foot lots as units. Consequently it is pertinent to ask whether a block shape that is designed to meet such obsolete conditions is the best possible unit of design for garden apartments. In deciding whether economy would permit the narrow block to be widened, it is a nice question as to how far the "wasting" of land, by throwing it into recreation space instead of into building, would be offset by the saving effected by eliminating some of the streets in the city plan.

But, whatever be the possibilities of the garden apartment in the future, the examples of it that now actually exist, and which are yielding remarkable results in practice, deserve all praise. Some of the more important features of the individual properties may be briefly noted.

Proceeding to the lowest class of rentals, the Homewood Apartments of the City and Suburban Homes Company, situated in Brooklyn, on 17th avenue, between 73d and 74th streets, were illustrated in the previous issue. This group is in an outlying district, placed amid groups of block housing, also individual dwellings, and much vacant land. The law does not require its construction to be fire-resisting in all respects, and inside, all, but the stairs, which are concrete, is of timber construction. The four apartments do not cover a full New York City block, but are confined to one end of it. Nevertheless, they are true garden apartments and the lot is not considered as a unit in their design. The group is so arranged in plan that it is really surprising how nearly all rooms, except those on the north, are reached by direct sunlight during several hours of the day. The garden space is ample, with really beautiful effects, which are not marred by the concrete service courts in the rear of each building, since these latter are sunk below the court level and are thus not to be seen. Like all Mr. Thomas's designs, the fire-escapes are tucked away







STREET FRONT OF 85-FOOT UNIT, OPERATION NO. 8 OF  
THE QUEENSBORO CORPORATION, BOROUGH OF QUEENS,  
NEW YORK CITY. ANDREW J. THOMAS, ARCHITECT.





ENTRANCE DETAIL—STREET FRONT OF 85-FOOT UNIT, OPERATION NO. 8 OF THE QUEENSBORO CORPORATION, BOROUGH OF QUEENS, NEW YORK CITY. ANDREW J. THOMAS, ARCHITECT.



PERSPECTIVE OF GARDENS IN COURT, SHOWING DRIVEWAYS AND GARAGES—OPERATION NO. 8 OF THE QUEENSBORO CORPORATION, BOROUGH OF QUEENS, NEW YORK CITY.

Andrew J. Thomas, Architect.

so that the perspective of the building cuts most of them off from sight from almost any point in the garden. The exteriors, while simple indeed, have an unusual quality—quality in scale, proportions of windows and entrances, and design of doors and details of ironwork, balconies, such as is usually found only in the finest kinds of architecture. In plan, the arrangement inside shows the rooms radiating from a couple of stair wells without corridors, there being three to four rooms in each apartment, including kitchen and loggia, which latter is a sleeping porch. The finish of the rooms is of the simplest, and, as a detail of Mr. Thomas's fine taste, I noted well-profiled 3-inch trims around door openings, like an early American farmhouse. The stair wells and entrances are of face brick. Though the rooms are small, they are larger than most rooms in this class of housing. These buildings are almost completed at date of writing, and are be-

ing rented. They cover 52 per cent. of the lot area, and, to quote the annual report of the company, yield as great, if not a greater, return on the investment than the older plans of concentration could do. The group is less than a quarter of a mile from the elevated railroad station.

Of course, this Homewood development costs much more to construct than apartments built before the war; consequently, it cannot be rented so cheaply as older apartments can. Still, it is proving a success financially, and has been put through in trying times, when competing speculators are impotent, how impotent will be realized when it is stated that plans for only about fifteen apartment houses on Manhattan Island have been filed with the New York Tenement Commission this year! More than that, at the moment of writing representatives of the New York speculative real estate interests are giving interviews in the daily



press, declaring regretfully that this Homewood achievement of the City and Suburban Homes Company is something that they cannot equal. "Because of its splendid business organization," they say.

Another type of housing for lowest class of rentals is the housing of the Open-Stair Company illustrated in the previous article. Two of the four units, containing space for 216 families, were completed in 1917. This company proposes to erect two similar units, leaving a large playground space between, thus having 50 per cent. of the lot area occupied with buildings. This again, like the Homewood Apartments, does not occupy a whole New York City block. It may be noted that this group of apartments is six stories in height. This is because these apartments are located in a congested district where the inhabitants are willing to walk up five flights of stairs; on the other hand, the Homewood Apartments, located in an outlying district, are four stories high, because that is the

custom of the district, which feels that three flights of stairs are enough to ascend.

The other developments come entirely in the second class of apartments, not so large, but very important nevertheless, of salaried workers, executives, foremen, trades people and professional men whose family incomes range from \$3,000 up to \$10,000. In these great developments of the Queensboro Corporation, the use of the block as the unit has reached its full development, as the result of progress and experience gained in several huge groups, four of them constructed with a New York block, or a block nearly as large, taken as a unit. These four units are interesting to us, since the other early ones do not greatly differ from the usual designs of speculative builders. All these Queensboro Apartments are located at Jackson Heights, an outlying district, but little built upon, and that little consisting mostly of two-story row housing, where the company owns a

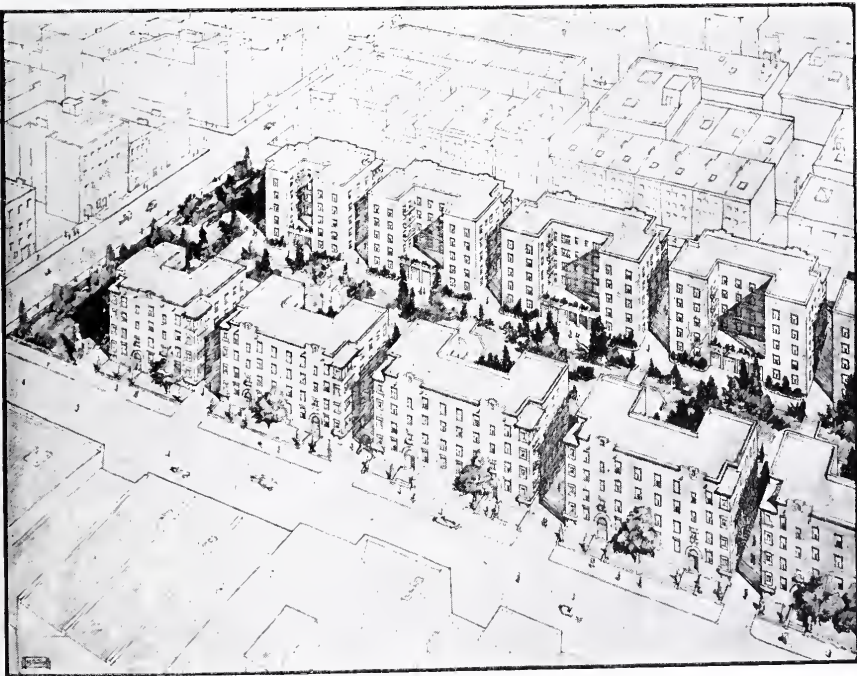

BIRD'S-EYE VIEW OF GARDEN APARTMENTS, OPERATION NO. 8 OF THE QUEENS-BORO CORPORATION, BOROUGH OF QUEENS, NEW YORK CITY.

Andrew J. Thomas, Architect.



TYPICAL UNIT IN OPERATION NO. 7 OF THE  
QUEENSBORO CORPORATION, BOROUGH OF QUEENS,  
NEW YORK CITY. GEORGE H. WELLS, ARCHITECT.



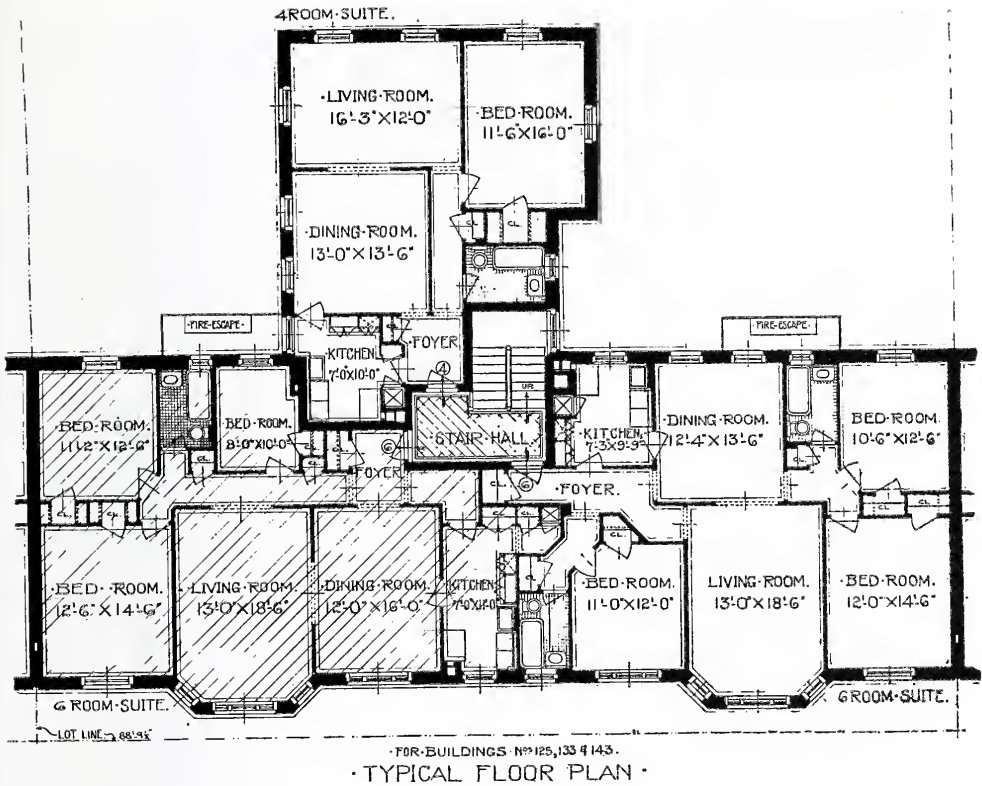

TYPICAL UNIT IN OPERATION NO. 9 OF THE QUEENSBORO CORPORATION, BOROUGH OF QUEENS, NEW YORK CITY.  
George H. Wells, Architect.

great tract of land which it is developing slowly each year with a great group or two, into a mammoth scheme. It is no less than a small city in itself. In the process a community center with a building is already established, churches are organized, community recreations, such as play grounds, golf links, gardens, are in operation on the corporation's land, stores are provided for, and other needs of a little city are planned for as they will be required. This, truly, is city planning!

The buildings on 23d street, Operation No. 7 in the corporation's history, are illustrated in these pages. This Operation No. 7, of which Mr. George H. Wells was the architect, is a well-planned development of block housing, with apartments along a wide front, and an ell containing

kitchens and maid's rooms—one maid's room for each apartment—projecting at the rear. The rooms are of fair size, with plenty of sunlight and good circulation of air, being practically two rooms deep. They are most comfortably and efficiently planned and equipped apartments. This group of buildings covers about 38 per cent. of the lot, and was completed in 1917 and 1918.

They are said by the corporation to be "the first application of the garden apartment type of plan in the City of New York." Nevertheless one must feel that in plan they lack most of the essentials of a garden apartment. No row was built on the other street of the block, and hence there is yet no interior garden court. Furthermore, nearly all the rooms front on the narrow street instead of on

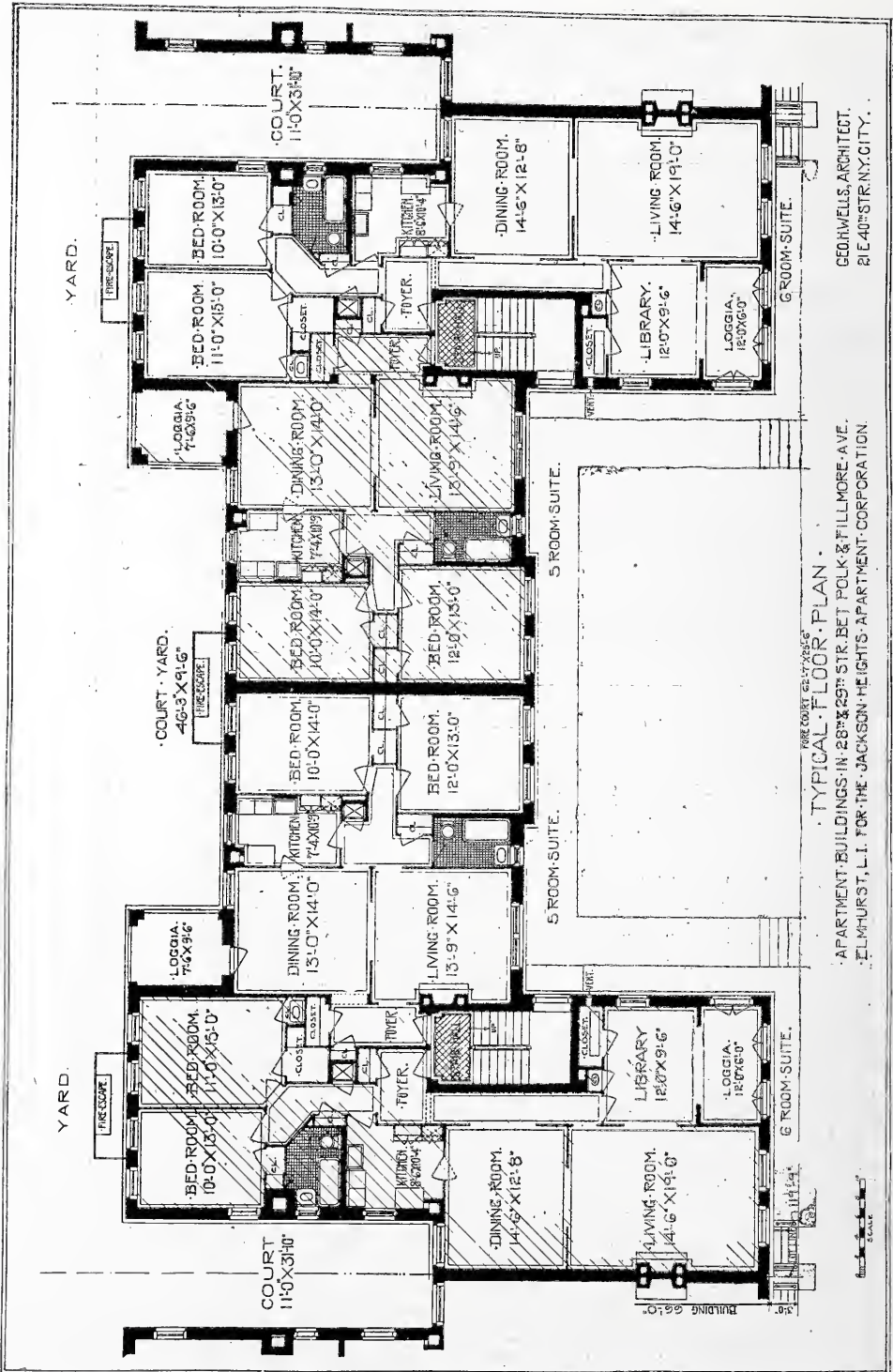

TYPICAL FLOOR PLAN

APARTMENT BUILDINGS IN 28<sup>TH</sup> & 29<sup>TH</sup> STR. BET. POLK & FILLMORE AVE.  
 ELMHURST, L.I. FOR THE JACKSON HEIGHTS APARTMENT CORPORATION.

GEORGE WELLS, ARCHITECT.  
 21 E. 40<sup>TH</sup> STR. N.Y. CITY.

TYPICAL UNIT IN OPERATION NO. 10 OF THE  
 QUEENSBORO CORPORATION, BOROUGH OF QUEENS,  
 NEW YORK CITY. GEORGE H. WELLS, ARCHITECT.



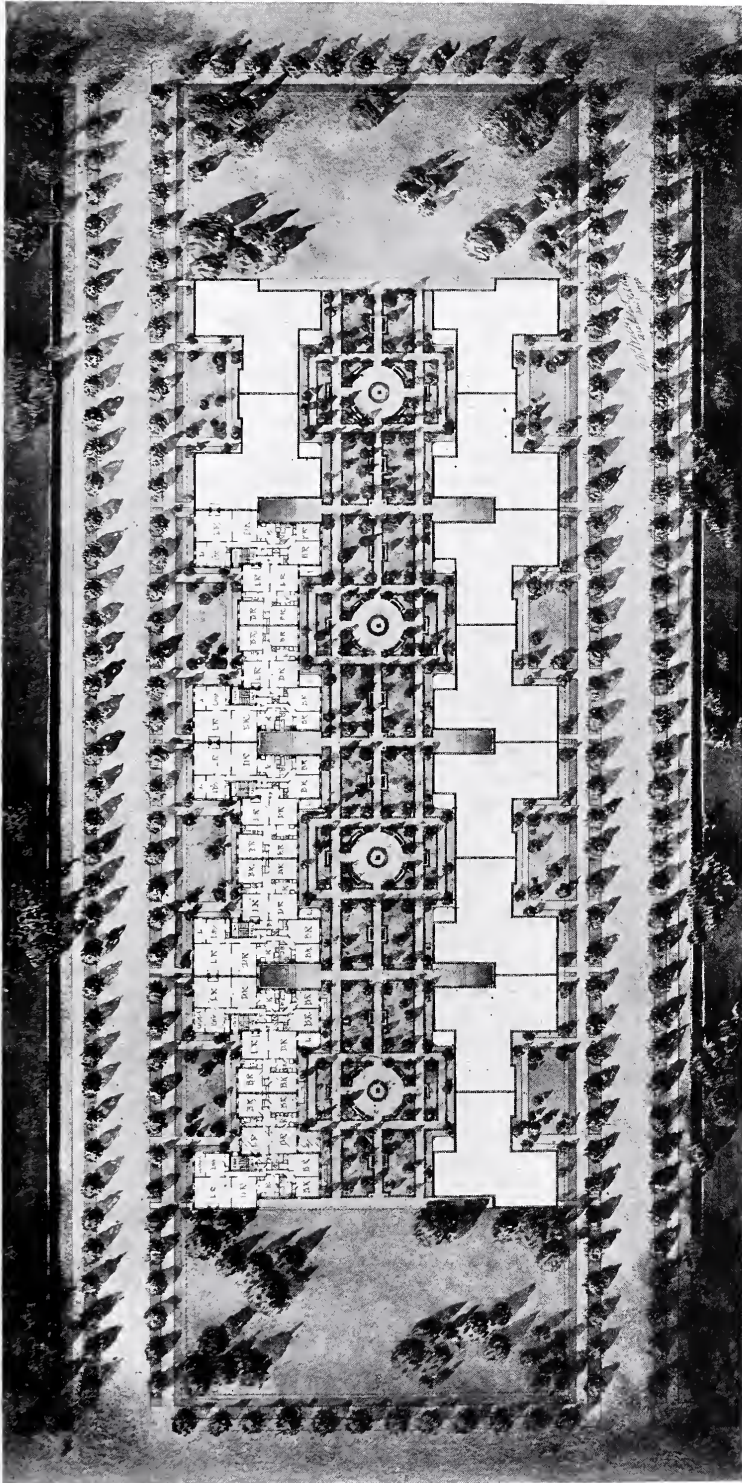

GROUP PLAN OF OPERATION NO. 10 OF THE QUEENS-  
BORO CORPORATION, BOROUGH OF QUEENS, NEW  
YORK CITY. GEORGE H. WELLS, ARCHITECT.

the rear of the more desirable garden—the old American real estate conception. Only kitchens and maid's rooms face the garden, and the rear elevations of the apartments are not designed at all, but instead are left unfinished in the bald, ugly manner common to row houses with "back yards." Thus both plans and elevations are adjusted to the street front solely, and reveal no conception of the garden court considered as an integral feature of the group.

The second great group, Operation No. 8, has just been completed. Mr. Thomas is the architect, and, in planning them, the row was abandoned for the group conception. They were planned in ten great units of three types, as described in the previous article. The block plan of the whole group and two of the units, the 120-foot and the 107-foot frontage units, as well as elevations and details, are illustrated in these pages.

In viewing this fine collection of buildings, with the splendid long garden in the interior, one cannot help feeling that here, considered from all points of view, is the highest achievement in the garden apartment that has been reached so far. It clearly places Mr. Thomas as the creator of the first true garden apartment group on a city block that has been designed as a whole. In it the garden is an integral part of the scheme; the rooms are planned to take full advantage of the fine garden outlook, and, besides, elevations on the garden are as attractive as those on the street fronts. In these fundamental respects it is totally different from all the earlier housing groups at Jackson Heights, which, whatever the conception behind them, as executed in plan and elevation, are only typical of the row housing.

Whether or not Mr. Thomas's group is as well planned in all respects, or better planned, in the eyes of the tenant of today, of the type which lives in Jackson Heights, I do not pretend to say. That is a matter of the particular real estate conditions local to the place. According to the management, some tenants prefer one type, some the other. But for those who care for

architectural appearances in cities, the advantage is all with the use of isolated buildings, resembling the university dormitory as mentioned above. In that case the Garden apartment as a group has form, scale, proportion, individuality. There is not that dreary, mechanical, institutionalized aspect of the whole block by which row housing has sucked out all the character and individuality from the streets of American cities. Each individual building of Operation No. 8, at Jackson Heights, has something of individuality, of "homeiness," that one does not expect to find in apartment houses, and surely cannot find in the row type. Their appearance at the rear, as soon in the court, is also far better than the row type, for the alleys between the buildings break up the length of the court, giving it character and form. The appearance of the long row housing, like No. 7, when viewed from the rear, is nothing if not distinctly ugly. In giving this opinion of the superiority of the grouped apartment over the row type, I do not wish to reflect on the admirable judgment of the Queensboro Corporation. They appreciate the defects in appearance of the row type in its usual form, and have had Mr. Wells plan a combination of the two types for a future group, No. 10, the block plan of which and an individual unit of it are herewith shown. In this scheme, the long, monotonous front of the street is broken up with setbacks or courts, and the rear wall is varied with setbacks and with narrow courts at intervals. When this plan is constructed, it will be interesting to see whether it will completely overcome the defects of the row type.

A few more details of these big Jackson Heights apartments remain to be noted. In construction, they are substantial enough, though not entirely of fire-resisting materials. The first floor only, and the stairs, are of fire-resisting construction. The interiors are simple, but in good taste, with kitchens and bathrooms containing very good fixtures. Halls and stairs are finished in the older buildings with terrazzo floors and marble wainscots. It is interesting to know



that, since the war, servants' rooms have not been given a particular place on the plans, though in some cases one bedroom is slightly apart from the others, and is smaller, and could be used for a maid. Maids are becoming extinct at Jackson Heights, for reasons too obvious to remark upon. There is no central heating plant, for two reasons—one is that the buildings were planned so that each unit could be sold separately, if desired; and the other is that the law requires a janitor for each building and thus the care of furnaces makes no additional expense in management.

This ends the description of the more important features of the Garden Apartments. Their economy is being proven by the test of experience even in the cheaper classes of housing. The City and Suburban Homes Company is demonstrating it under the most difficult conditions of all—housing for the wage earner; while the Queensboro Corporation is carrying out its principles on a colossal scale for the housing of the class just above in the economic scale. The Queensboro Corporation has given us the first models of it from the ideal point of view, because, working with a higher rental scale, they have more flexibility and opportunity in design. They give a surprising amount for the rental. Like the City and Suburban Homes Company, they are able to build even when the speculator cannot.

The Garden Apartments are the latest—and by far the finest—development in the progress that began twenty years ago when the Tenement Act of 1901 placed the first real check on the intolerable housing practices of New York City. These first beginnings were legal, restrictive, and lay mostly in the domain of sanitation and of public welfare. Thereafter, with bad housing definitely forbidden, interest centered in architecture and finance, with the aim of developing types of good housing. The economic changes wrought by the war favored the birth of the Garden Apartment to the extent that the vast increase in cost of construction made it even more advisable than formerly not to overcapitalize real estate investment by overbuilding the land. Concentration became more evidently an evil, and with this truth apparent, Mr. Thomas was able to create his wonderful models, with the city block conceived as a unit. True, the garden apartment may not yet have reached its full possibilities, but already it bids fair to furnish American city housing with ideal standards comparable to those established for small communities. Through this achievement, perfected in design, finance and management, and properly related to an efficient city plan, the modern commercial and industrial city may take on a form, a coherence, an orderliness, and a wholesomeness, which up to this time it has never had.



RURAL SCHOOL, BARRIO  
POLEOL, SALINAS, P. R.



# RECENT CIVIC ARCHITECTURE IN PORTO RICO

*Adrian C. Finlayson, Architect for the  
Insular Department of the Interior*

BY SYLVESTER BAXTER

VISITORS to Porto Rico are invariably impressed by the admirable quality of the modern civic architecture that abounds in all sections of the beautiful island. There are few towns that do not possess at least one fine schoolhouse, and not infrequently in such a town may be seen two or three other notable public buildings. In particular the citizens are justly proud of their handsome schoolhouses, usually the most monumental building in the place, even outranking the parish church. The impress thus made upon the island's aspect, imparting a distinctively new note to its architectural quality that keeps well in accord with its Spanish traditions, speaks highly for what has been achieved by American influence in the little more than two decades since Porto Rico became United States territory.

It is doubtful if any State of the Union has exerted from a central source so general an activity in the construction of civic edifices as has the insular government of Porto Rico since its reorganization under the Stars and Stripes. The Interior Department of the territory has extensive constructional functions, such as building highways, bridges and other public works throughout the island, together with the designing and erection of such public buildings as may be authorized and entrusted to it by insular or municipal authorities. The local authorities, to be sure, have the right to erect their own civic buildings. But the Interior Department is so well equipped for this work, and has such a name for excellence in design, that very sensibly they prefer to delegate the designing and execution to the central authority. Moreover, the public school system of Porto Rico is highly centralized under

the control of the Insular Department of Education, being organized with uniform standards for the entire island under the direction of the Commissioner of Education appointed by the President of the United States. The post, which for a long time has been admirably filled by Dr. Paul H. Miller, is thus removed from interference by local politicians. This circumstance naturally tends towards the designing of school buildings by a competent central authority familiar both with the best standards of construction and with the peculiar requirements of a tropical environment, since all plans for school buildings have to be approved by the Department of Education.

The architect of the Interior Department has for some years been Mr. Adrian C. Finlayson, a native of the States and a graduate of the department of architecture at Syracuse University, New York. The department's architectural division, occupying a large part of the second floor of the interesting old Government Building on the east side of the Plaza de Baldorioty, in San Juan, has a large and well organized office-force, consisting for the greater part of native Porto Ricans, but including a few young men from the States attracted by the charms of a tropical climate and the opportunity to familiarize themselves with the requirements of construction under tropical conditions, so different in various important respects from those imposed by a northern climate. The work turned out by these young Porto Rican draftsmen attests the existence of much local artistic talent. No greater competence could be desired than that shown by the talented chief draftsman of the office, Mr. Francisco Roldán, who in a course

of architectural study in Spain has enjoyed excellent opportunities in the line of professional training.

Mr. Finlayson's work covers a diversity of subjects: schoolhouses, urban and rural, institutional buildings, city halls, market houses, hospitals, bridges. As compared with a like class of work to be dealt with under northern conditions the problems are materially simplified—something well worth the attention of our architects here in the States, to whom the rapid development of tropical regions now going on is prospectively bringing an ever increasing number of important commissions. Unfamiliarity with tropical conditions on the part of our architects, who not infrequently have designed work for tropical localities in absentee fashion, has often led to ludicrous errors and greatly increased building costs for the client. The builder of an important hospital in a tropical city, for instance, told the writer that even after he had, by urgent representations, obtained a reluctant elimination of the steam-heating plant included in the plans, there yet remained various unnecessary requirements insisted upon by the architect that made the cost of the building something like fifteen thousand dollars greater than it need have been. The Carnegie Library in San Juan, designed in a New York office with little reference to climatic conditions, is by no means well suited to West Indian circumstances. One defect is a failure to realize the situation arising from the frequent showers, often several in the course of the day, brought up by the trade-wind; in consequence it is frequently necessary for attendants to run around and close the shutters at the window openings. This could have been obviated by designing the building with an arcaded exterior. But a type of library design was selected that in the States has become traditional since the building of the Boston Public Library. A member of the Board of Trustees told the writer that a competent representative had been sent to inform the architects as to local conditions, but that little attention was paid to him.

The simplification of structural prob-

lems under tropical conditions is due, among other things, to such circumstances as the fact that there is no occasion for going below a "frost-line" for one's foundations; that there is no cold to be kept out of the building, and that consequently double exterior walls are not required, and provisions for artificial heating are unnecessary. Chimneys are also dispensed with as a rule, the exceptions being where wood or coal may be called for in cooking. But in cities like San Juan, gas, electricity or kerosene are used in the kitchen. And where there are smokeless products of combustion, as in the case of charcoal, gas or kerosene, there is still no call for a chimney to take them off, the breeze carrying them out of the always open windows or doors. For the better-class dwellings, situated at an altitude in the country or in towns among the mountains, open fireplaces are desirable.

Reinforced concrete is practically the universal building material in Porto Rico today. Its relative cheapness, its strength and its durability recommend it. It is here employed with remarkable ability, and has been a notable factor in the development of locally typical forms of design. As elsewhere, for a brief period concrete blocks had a vogue, but their day is past and they are no longer in use. Limestone and granite abound in the interior of the island, but transportation-costs make them unavailable, except possibly for exceptional purposes. A quarry of marble, said to be as good as the best Italian in quality, has lately been opened up near San Juan, close to a railway line. So this material may come into use in connection with the steel-frame construction increasingly employed in the semi-skyscraper commercial architecture of San Juan, and also for decorative interior finish. But reinforced concrete has entirely superseded the old-time construction of either *mamposteria* (rubble) or soft brick, a construction with phenomenally thick walls, in use since the earliest Spanish times—a factor that lay at the root of the terrible havoc wrought by the earthquake in 1918 at Mayaguez and other west coast towns.





ROMAN BALDORIOTY DE CASTRO GRADED AND TECHNICAL SCHOOL, SAN JUAN, P. R.

In Mr. Finlayson's work there is only one exception to the universal employment of reinforced concrete, and that is the important Rafael M. de Labra graded school in Santurce, the great suburban and residential district of San Juan; a beautiful example of Georgian architecture applied to a tropical environment: one of the show-buildings of the city. It is wholly of red brick, with trimmings of white terra cotta. Although looking as if it might have stood in old Boston or Philadelphia, so far as aspect and material are concerned, and unique in style for San Juan, it is in such good keeping with its environment, with its gracious façade, its airy arcaded corridors and court, and the light elegance of its belfry, that it seems by no means an architectural exotic. The excellent hard brick of the walls came from the south side of the island near Ponce. The walls are so well tied together with steel rods at crucial points that the building stood the ordeal of the recent severe earthquake without a trace of damage.

The comparatively thin single walls made possible by the use of reinforced concrete, together with the other simplifications in building and equipment aforementioned, and also the lesser labor costs, effect such economies in construction that altogether the higher cost of material, due to transportation, is more than counterbalanced. For instance, the plastering of rooms can be done directly upon the inside surface of the exterior wall, instead of providing a space between the plastering and the wall; indeed, in certain instances no plastering at all is necessary, for I have seen most attractive rooms with the bare concrete walls left untouched just as they came from the forms.

In the modern as well as the old-time civic architecture of Porto Rico glass windows are seldom, if ever, in evidence. I cannot recall a single instance except a glazed space commonly provided in the upper part of the shutters, as may be seen in various illustrations here given. In such a climate they would be super-

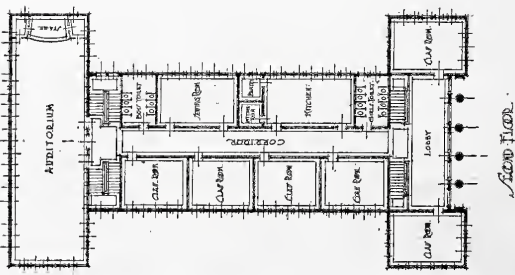

FIRST FLOOR

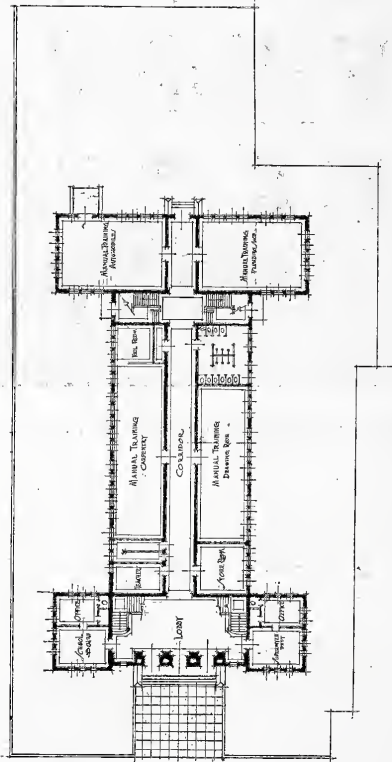

SECOND FLOOR

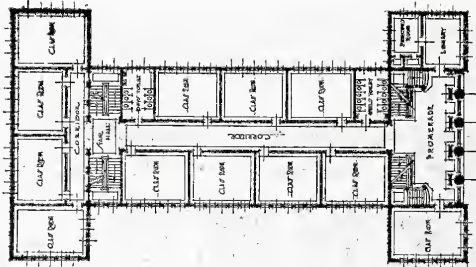

THIRD FLOOR

GRADED & TECHNICAL SCHOOL  
 SAN FRANCISCO PLAZA, SAN JUAN, P.R.

ROMAN BALDORIOY DE CAS-  
 TRO GRADED AND TECHNICAL  
 SCHOOL, SAN JUAN, P. R.

SCALE IN FEET  
 0 10 20 30 40 50 60



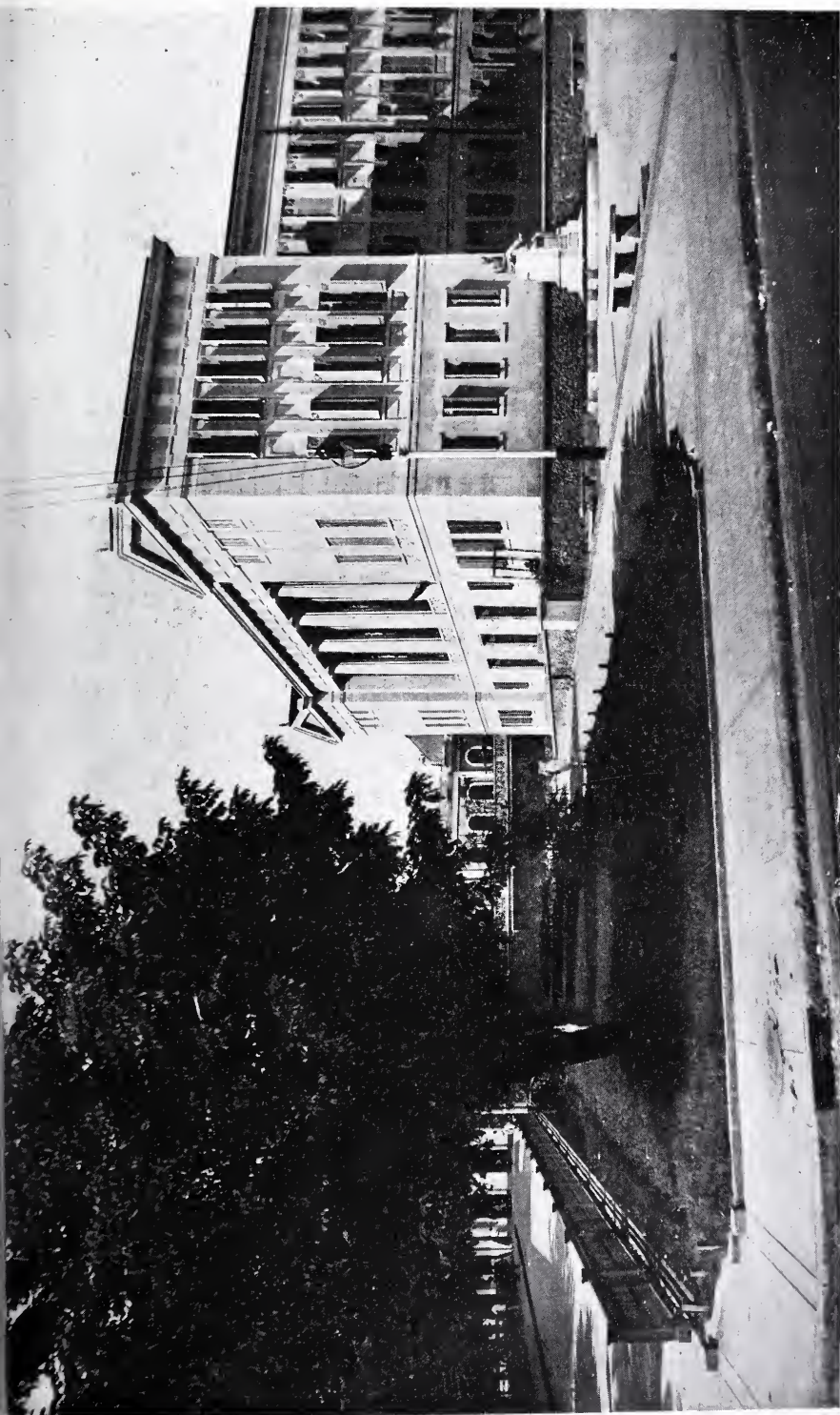

ROMAN BALDORIOTY DE CASTRO  
GRADED AND TECHNICAL  
SCHOOL, SAN JUAN, P. R.



REAR VIEW—RAFAEL M. DE LA-  
BARRA GRADED SCHOOL, BARRIO  
SANTURCE, SAN JUAN, P. R.





FRONT VIEW—RAFAEL M. DE LA-  
BRA GRADED SCHOOL, BARRIO  
SANTURCE, SAN JUAN, P. R.

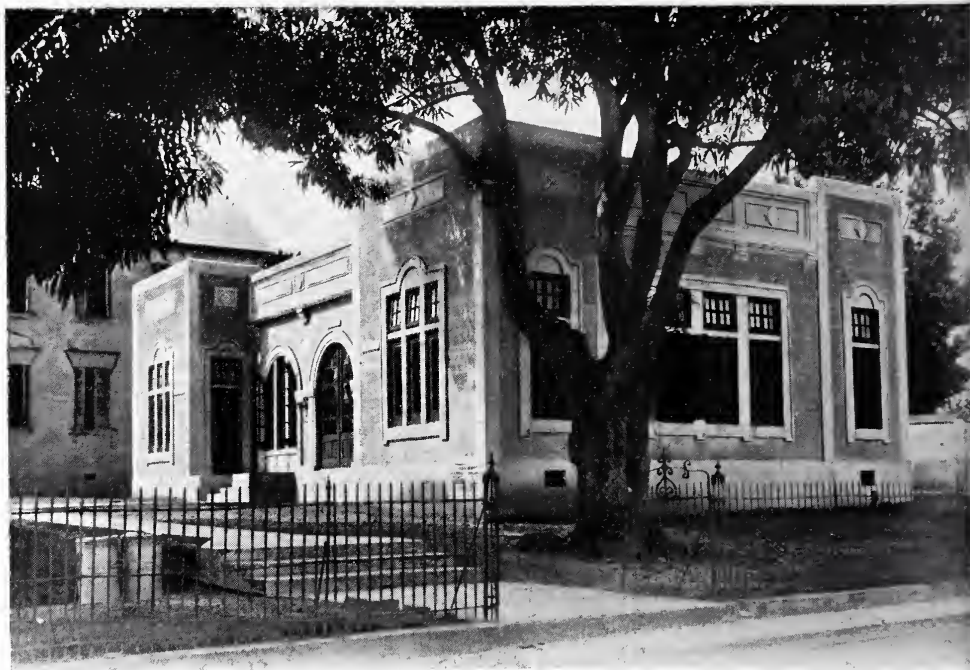

LIBRARY AND OFFICE BUILDING OF THE SCHOOL DEPARTMENT, MAYAGUEZ, P. R.

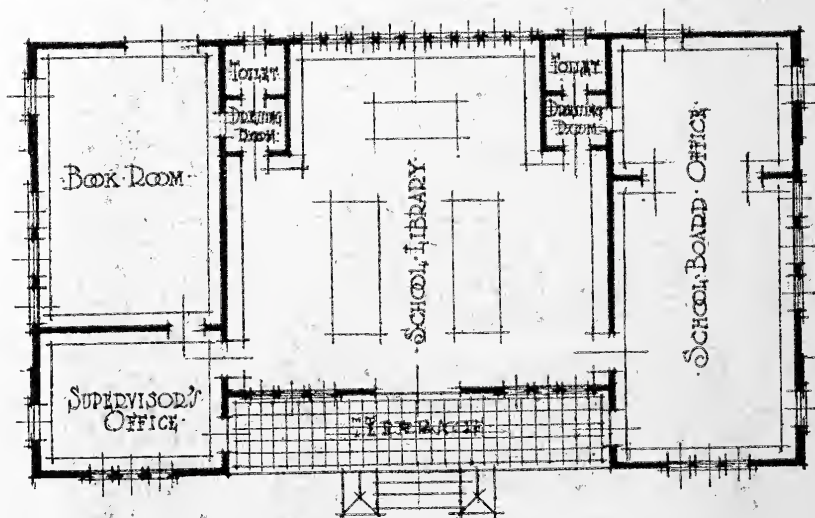

FLOOR PLAN

SCALE:



LIBRARY AND OFFICE BUILDING OF THE SCHOOL DEPARTMENT, MAYAGUEZ, P. R.



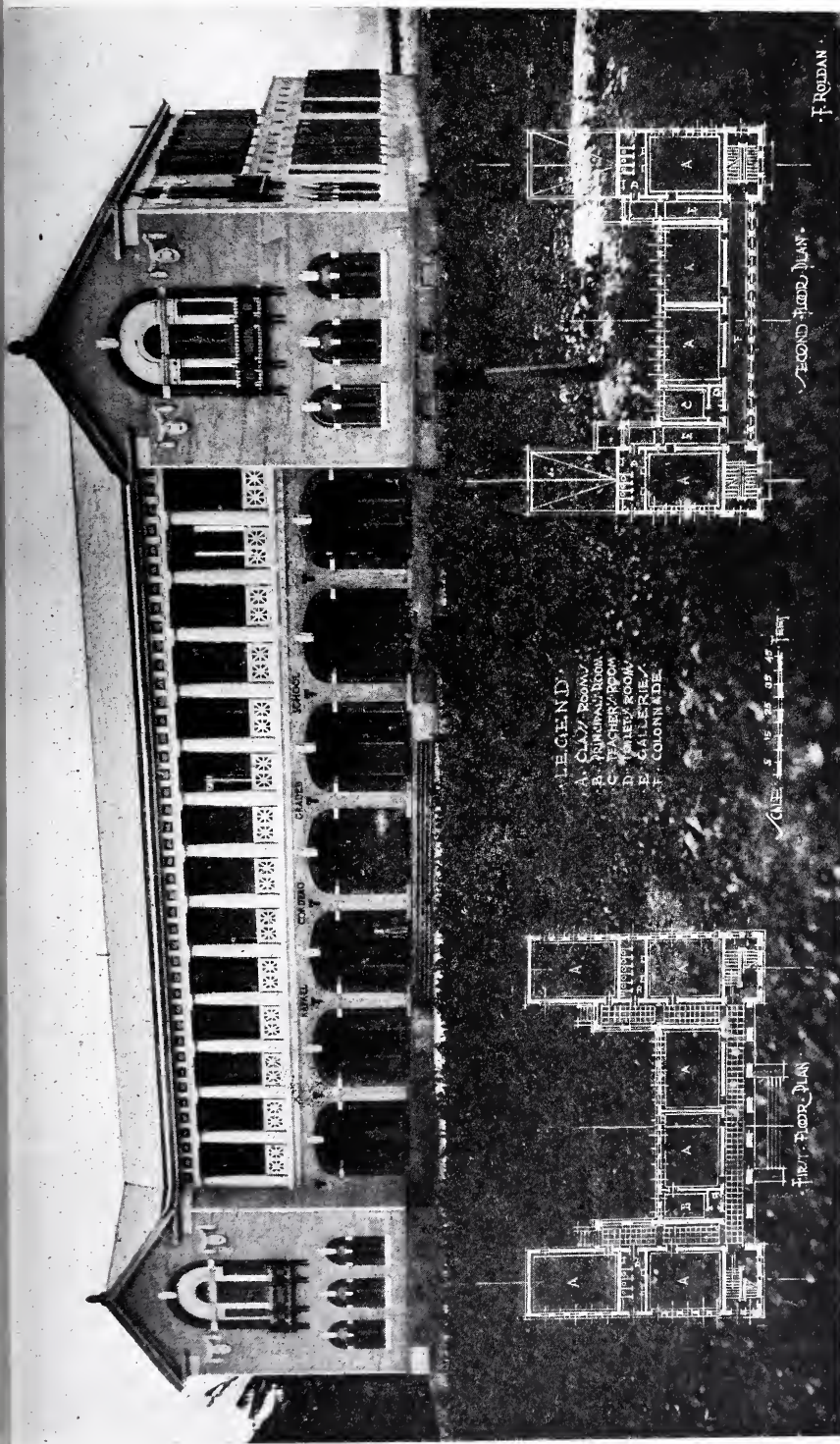

SCHOOL BUILDING · SANTURCE · SAN JUAN · P.R.  
 ADRIAN C. FINLAYSON · ARCHITECT

RAFAEL CORDERO GRADUATED SCHOOL, BARRIO SANTURCE, SAN JUAN, P. R.

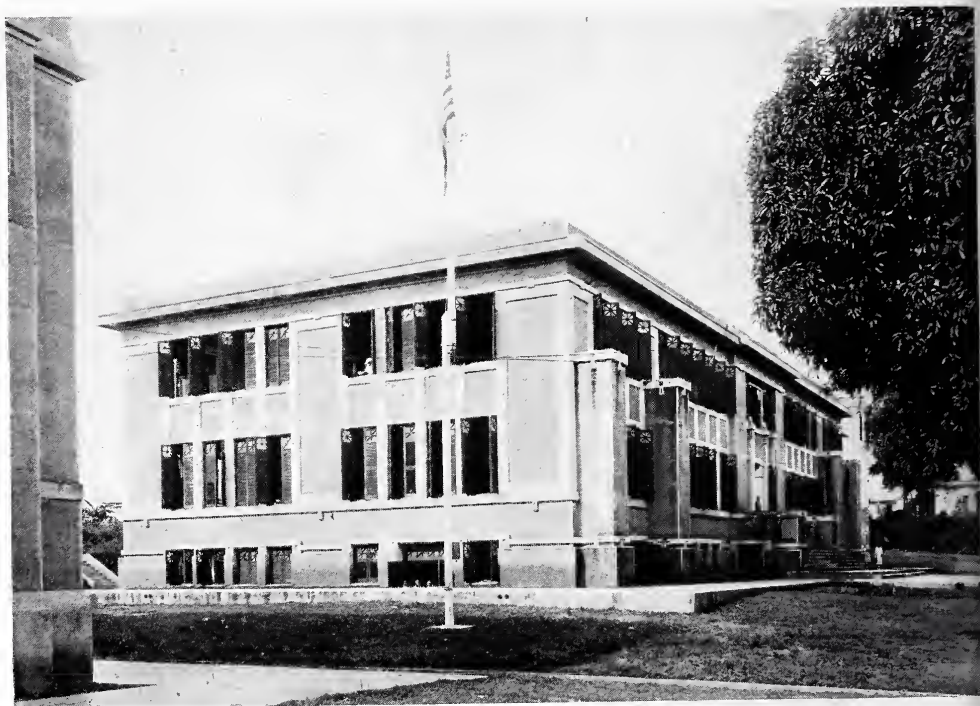

HIGH SCHOOL IN MAYAGUEZ, P. R., OF REINFORCED CONCRETE CONSTRUCTION. IT SURVIVED UNINJURED THE EARTHQUAKE OF 1918, WHICH DESTROYED NEARLY THE WHOLE OF THE CITY.

fluous. The entire window-space, as a rule, is open to light and air. The window openings are of ample dimensions and there is usually a refreshing breeze to modify the tropical heat, seldom excessive or uncomfortably felt in a climate so even that one can always dress for it in light clothing. Even directly under the sun there is such a breeze that the heat is seldom oppressive. In case of the frequent showers the window-shutters are closed for the time being if there happens to be a driving wind. Strangers from the States, on being shown over a schoolhouse when the school is in session, are struck by the absolute purity of the air due to the large open windows. There is not a trace of the characteristic "schoolhouse smell" so familiar under northern conditions, even in buildings where particular attention is paid to a scientifically modern ventilating system—an odor that lingers in rooms and corridors even when they are empty. In Porto Rico there is nothing of that.

In his schoolhouse designs Mr. Finlayson has aimed to provide ample window-space. The atmosphere is substantially that of out of doors; there could be no logical call for special outdoor schools for sickly pupils here; every school is practically in the open.

A north light is also aimed at wherever practicable. This is not always feasible; for instance, the conditions of the site in case of the great Román Baldorioty de Castro School in San Juan made it necessary to provide as many classrooms on the south as on the north side. This important graded and technical school, with its eighteen class-rooms and nearly as much space devoted to technical and other purposes, is the largest school building in Porto Rico, and also the latest to be completed.

The building occupies the site of the ancient Franciscan monastery, demolished to give way to it, only the church, almost adjacent, remaining. The extraordi-



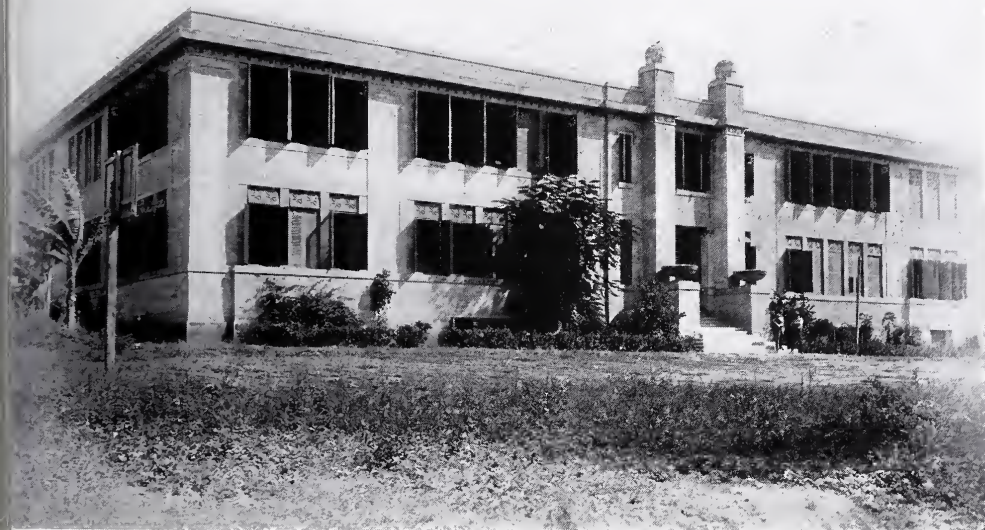

HIGH SCHOOL IN ARECIBO, P. R.

arily massive exterior walls of the monastery were left standing while the new edifice was going up behind them, masking the work so completely that few passers-by suspected what was going on inside. So when the monastery walls were torn down the new building, standing forth in full completion, was a revelation. The chastely beautiful façade, with its unhackneyed disposition of classic elements, has an effectiveness strikingly in keeping with climatic conditions that invite a gracious airiness in design imparted by the columnar motive employed to develop the attractive galleried features of the promenade and lobby of the first and second floors, respectively, with handsome double stairways rising from the entrance lobby on the ground floor.

An excellent feature of the handsome Georgian design of the Rafael M. de Labra School in the Santurce district of San Juan is the large cloistered patio between the two wings, the class-rooms giving onto its open galleries and kept remote from the noise of the busy main

traffic artery of San Juan, the "Carretera," or Avenida Ponce de Leon. Another notable school-building of recent construction in San Juan is the Rafael Cordero School, also in the Santurce *bárrio*. It might, like so much that is Spanish, be difficult to assign the style of this design, but in its rather joyous compositeness it has decidedly Romanesque implications, with a touch of the Plateresque.

A sparkle of color is given to the concrete surfaces by the red brick ornamentation that imparts strength and richness of outline to the arcade and the window-spaces. Possibly a purist might object to the alternate columns in the open gallery of the second story that center upon the arches below. But in this case the fact that the arches, being of reinforced concrete, are monolithic in character, justifies a quite conscious departure from a good rule for the sake of a feature of undeniable beauty.

In all these examples of Mr. Finlayson's work in reinforced concrete that herewith find illustration the architect

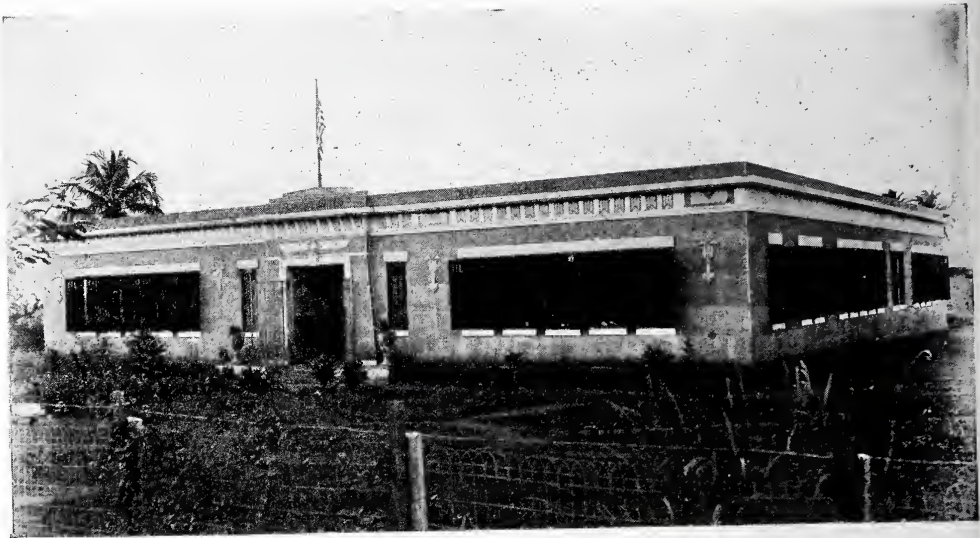

SCHOOLHOUSE FOR CONSOLIDATED RURAL SCHOOLS, BARRIO SANTANA, ARECIBO, P. R.

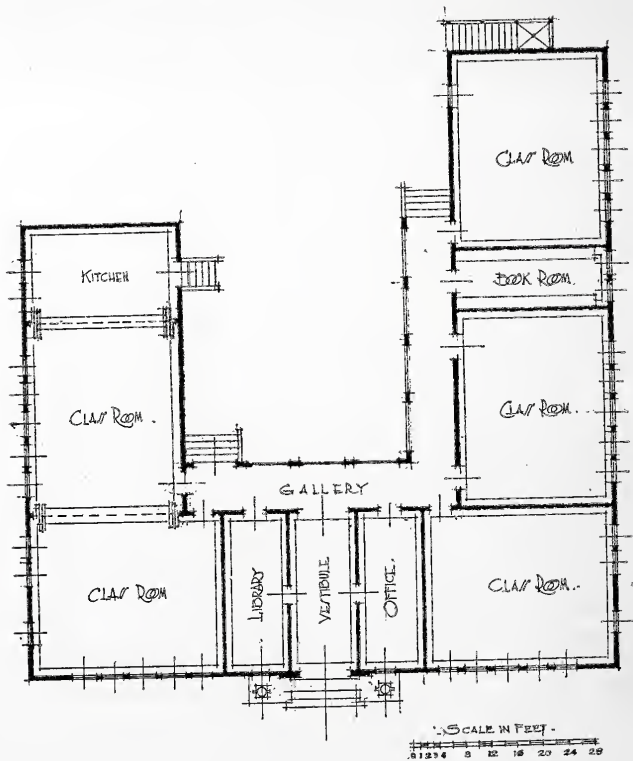

FLOOR PLAN.

SCHOOLHOUSE FOR CONSOLIDATED RURAL SCHOOLS, BARRIO SANTANA, ARECIBO, P. R.



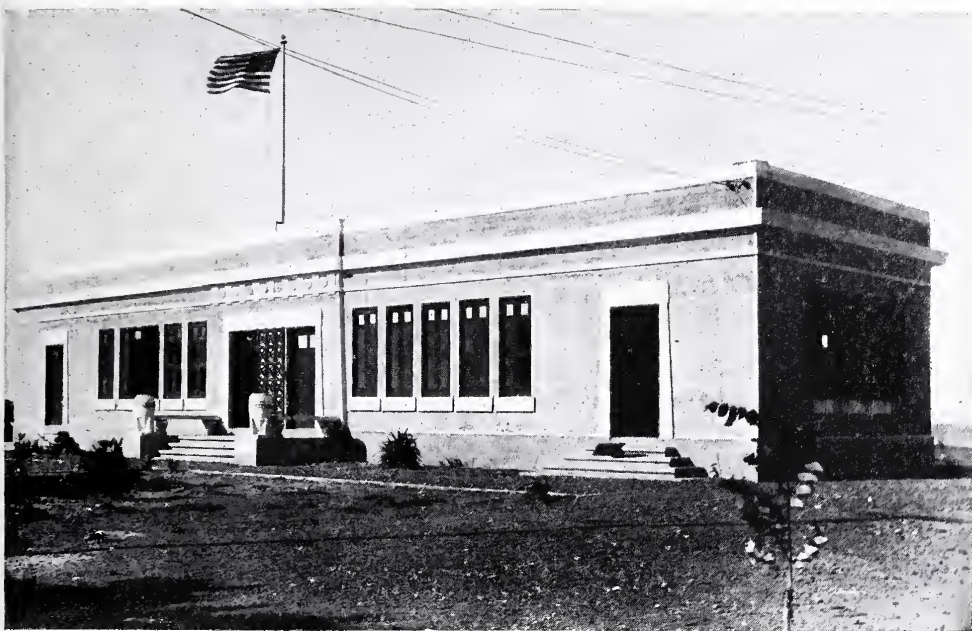

RURAL SCHOOL IN LUQUILLO, P. R., WITH TWO CLASS ROOMS, A LIBRARY AND PROVISION FOR INSTRUCTION IN DOMESTIC SCIENCE. THE GIFT OF DR. SANTIAGO VEVE TO THE MUNICIPALITY.



HONOR COTTAGE AT INSULAR REFORM SCHOOL, MAYAGUEZ, P. R., WHERE BOYS ARE HOUSED WHO MERIT DISTINCTION FOR GOOD CONDUCT.

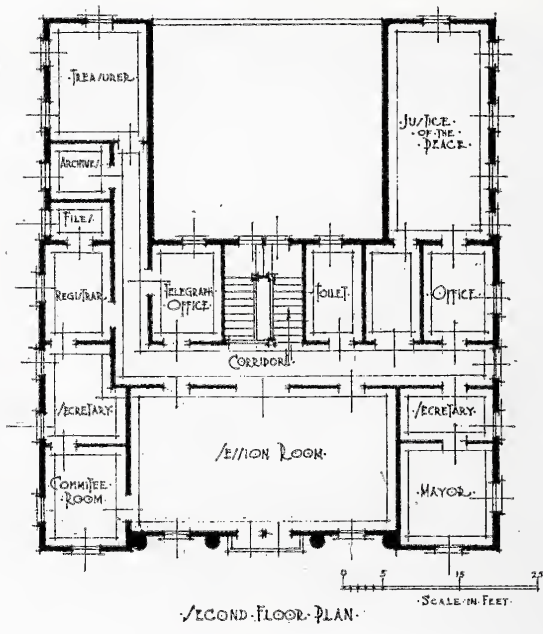

SECOND FLOOR PLAN

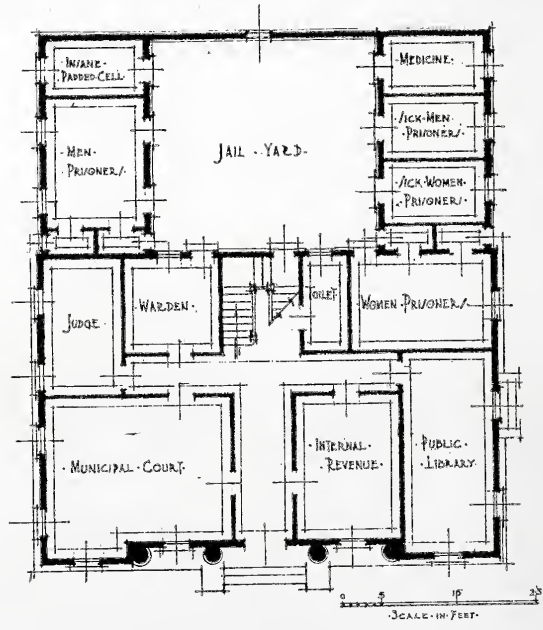

FIRST FLOOR PLAN

ALCALDIA MUNICIPAL (CITY HALL) OF THE MUNICIPALITY OF SALINAS, P. R.





ALCALDIA MUNICIPAL (CITY HALL) OF  
THE MUNICIPALITY OF SALINAS, P. R.

MUNICIPAL MARKET BUILDING

DIO PIEDRAS, P.E.

SCALE IN FEET

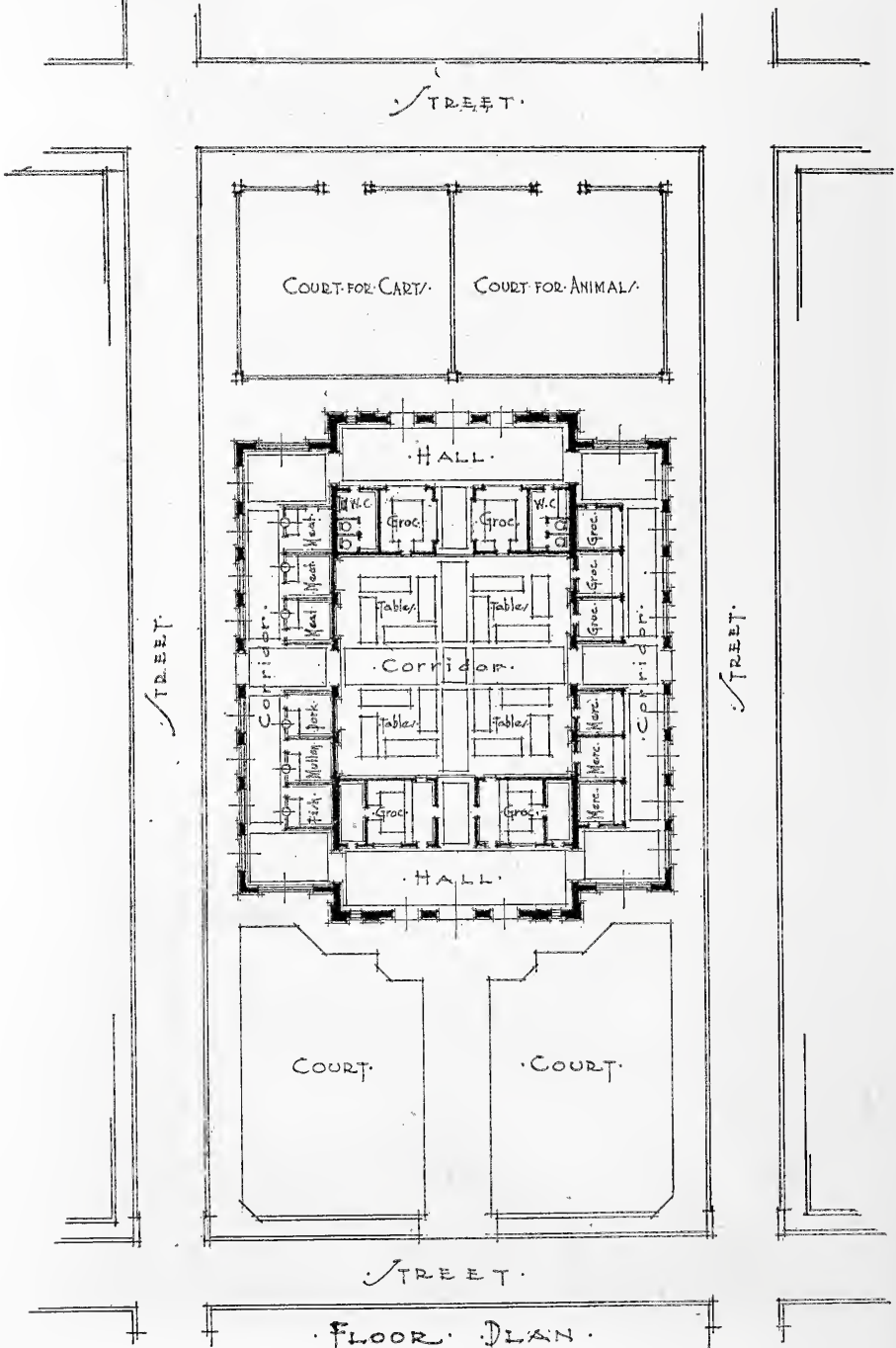

FLOOR PLAN.





MUNICIPAL MARKET IN RIO PIEDRAS, P. R.

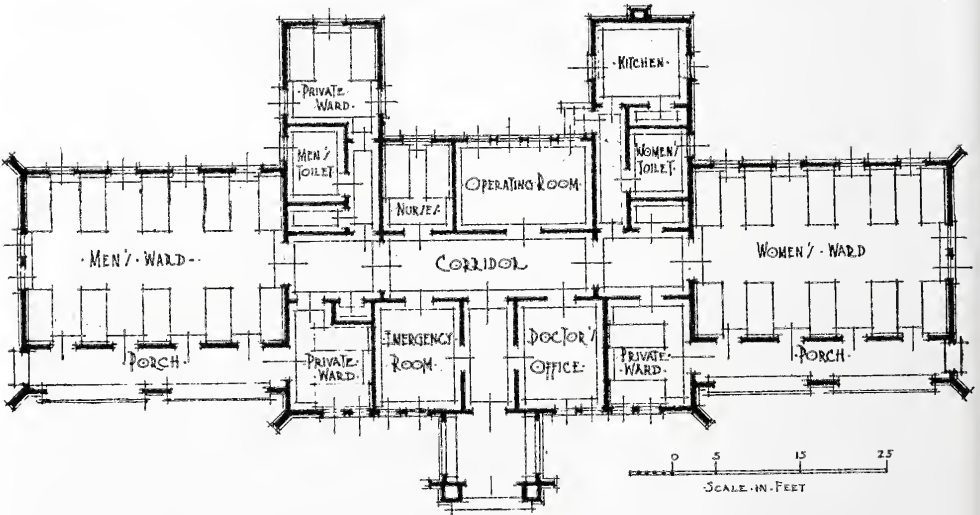

MUNICIPAL HOSPITAL IN FAJARDO, P. R.



shows an easy mastery of his materials, so tractably plastic that, while lending itself to the facile employment of the grammar of the art as developed from the technique of stonemasonry, it legitimately permits itself to transcend the limitations in design imposed thereby and to express itself on occasion with a wider freedom. Yet there is no running to eccentricity because of this. On the contrary, the work is remarkably restrained in its task of giving, without constraint, expression to the organic character of the structure. Hence we have the primarily monolithic quality of the material well sensed in the unitary character of broad, restful surfaces that make effective settings for the light openness of grouped perforations in windows and doorways.

How attractively these simple elements may be composed is shown in the long, low building of the four-room school with its arched porch and overhanging roof of red tile, built for the municipality of Salinas for the Central Aguirre, the second largest sugar-producing plant in Porto Rico, the children of the employes there finding instruction. The little one-room rural school built for the same municipality indicates how fortunate a town may be when it has its treasury enriched by the taxes derived from a great industry. These rural schoolhouses, the equivalent of the "little red schoolhouse" of old time rustic New England, standing along the highways all through the island, are for the greater part cheap, wooden affairs, hardly above the grade of shacks. But, as in New England and various other sections of the States today, where the children of the countryside in many sections enjoy schooling opportunities that in former days would have been as impracticable as they were undreamed of, by concentrating their rural school populations in excellently equipped modern schoolhouses at central points, taking the pupils to and fro in motor buses, so in various sections of Porto Rico a like advance has been made. An admirable example is the five-room schoolhouse built by the municipality of Arecibo—in population the fourth city

of the island—for its outlying *bárrio* of Santana. In Spain and very generally throughout Spanish America a municipality is not merely a city, but something similar to a wide-extending township in New England—like Plymouth, Massachusetts, or Barnstable, on Cape Cod—comprising a central town or city with perhaps several outlying districts or *bárrios*, usually rural in character, and occasionally having sizeable concentrated populations in villages, the municipality bearing the name of the central urban portion and all under one local government. The Arecibo consolidated rural school at the *Bárrio* Santana offers in its design an excellent illustration of how well concrete construction lends itself to the employment of Egyptian motives—in this example, the liberal space devoted to window openings conveying an effect of cheerfulness that bars any suggestion of the mausoleum-like character so commonly associated with Egyptian architecture. Another instance of such school consolidation is the handsome two-room rural school with library and domestic science department, a gift to the municipality of Luquillo, in the eastern part of the island, by the public-spirited citizen, Dr. Santiago Veve.

A notable example of another class of civic architecture is Mr. Finlayson's dignified and handsome city hall, or *Alcaldia Municipal*, for the municipality of Salinas. Here, on the first floor, such diverse uses as a public library, internal revenue office, court-room and prison are accommodated; while on the second floor, the executive, legislative and administrative functions and offices of the local government are provided for, together with the quarters of the justice of the peace.

The plan and illustration of the Municipal Hospital at Fajardo show an admirable example of the increased attention given since the American occupation to such activities in Porto Rico. The plans and illustrations of the municipal market buildings at Rio Piedras and Bayamon depict two of the best examples of an institution common to practically all the larger municipalities of the island.

TWELVE CLASS ROOM SCHOOL BUILDING  
CAYEY P. R.

SCALE IN FEET  
0 4 8 12 16 20 24 28 32 36 40 48

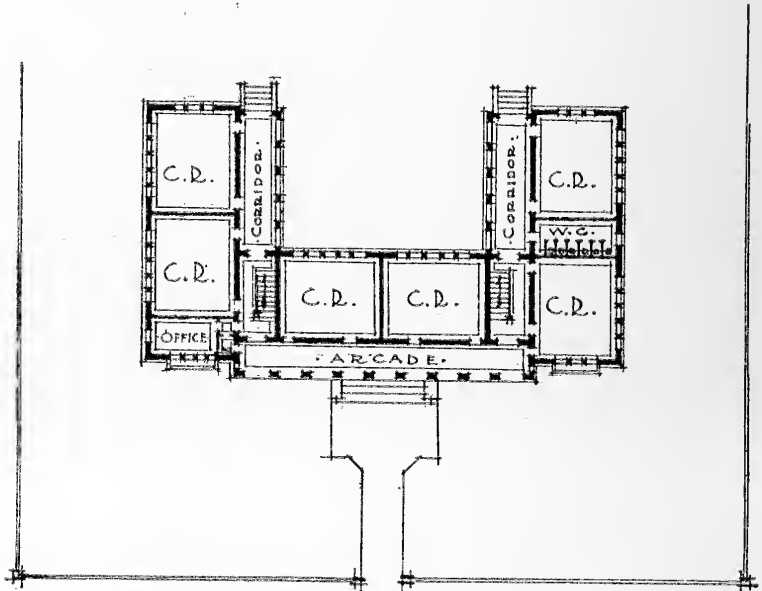

- FIRST FLOOR PLAN -

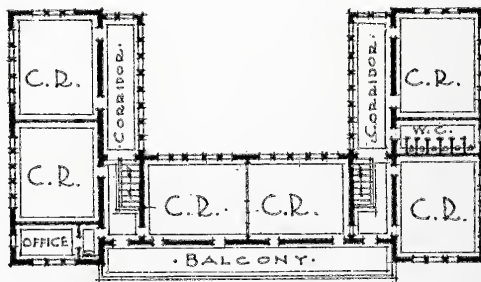

- SECOND FLOOR PLAN -





TWELVE-ROOM SCHOOL IN CAYEY, P. R.

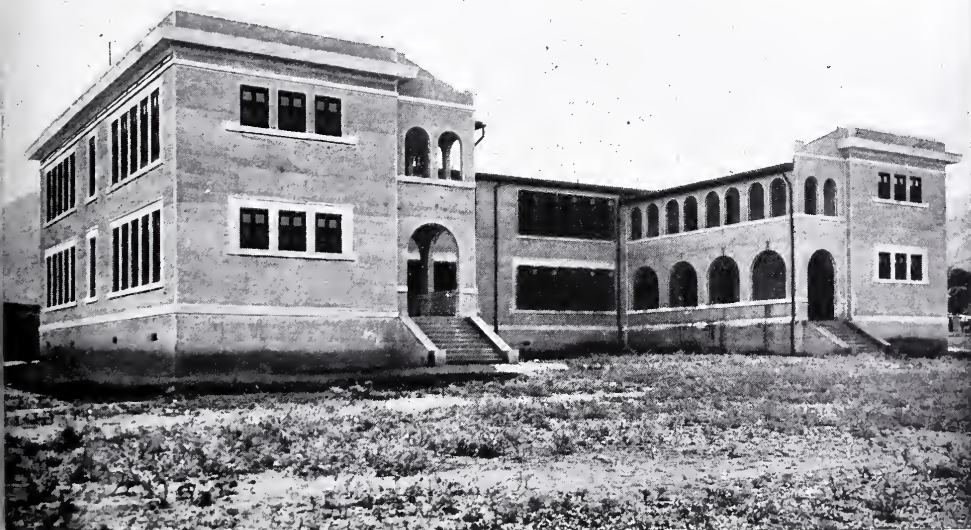

REAR VIEW—TWELVE-ROOM SCHOOL IN CAYEY, P. R.



BRIDGE OVER THE INABON RIVER, ON THE ROAD BETWEEN PONCE AND SANTA ISABEL, P. R.

A strikingly beautiful example of a modern type of bridge-design, originating with the adaptation of reinforced concrete to bridge construction, is the bridge that carries the coast road on the south side of the island between Ponce and Santa Isabel across the Inabon river. In its effect of gracious lightness it economizes in the maximum the use of concrete while expressing the steel reinforcement that makes possible the delicacy in design conveyed in the airy spring of the arches. The Inabon river is celebrated in local history as the stream where the aboriginal people of Borinquen, as Porto

Rico was originally called, put to the test the claim of the Spanish conquerors to divinity. The Spaniards were for a while held in awe by the natives, who were made to believe that the white men were gods. But the natives said among themselves: if they are gods they are immortal; they cannot die. So one day, when they came across a Spanish soldier alone near this river they took him to the stream and held him under water sufficiently long for the drowning of a mortal being. And when they brought him to the surface, finding him dead, they realized that white men were not gods.



Some Drawings  
of  
Older New York

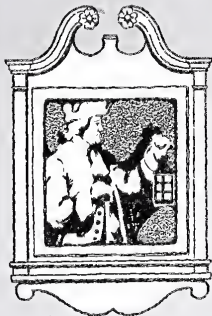

By  
John Di Mariano

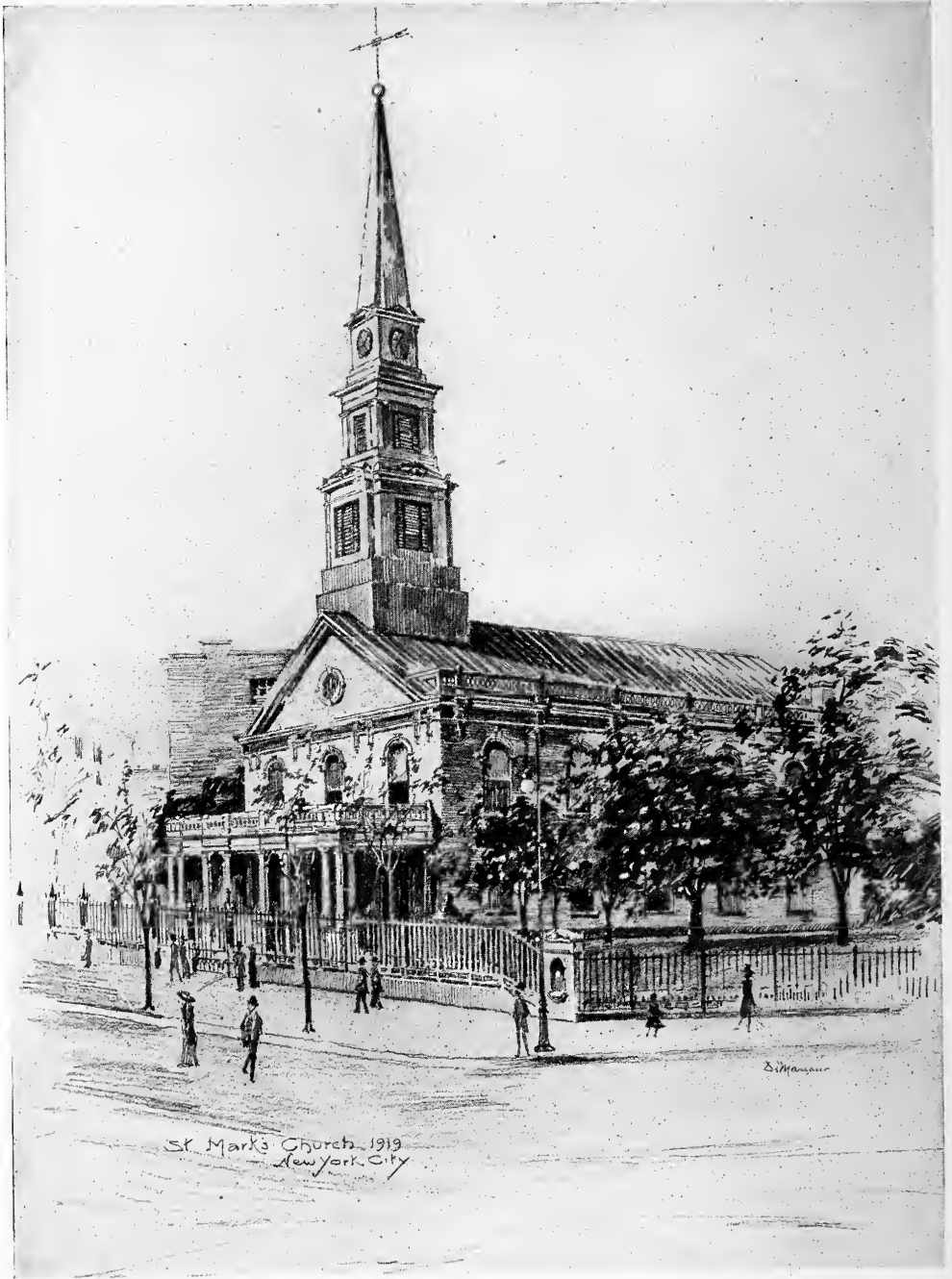

DRAWING BY JOHN DI MARIANO.



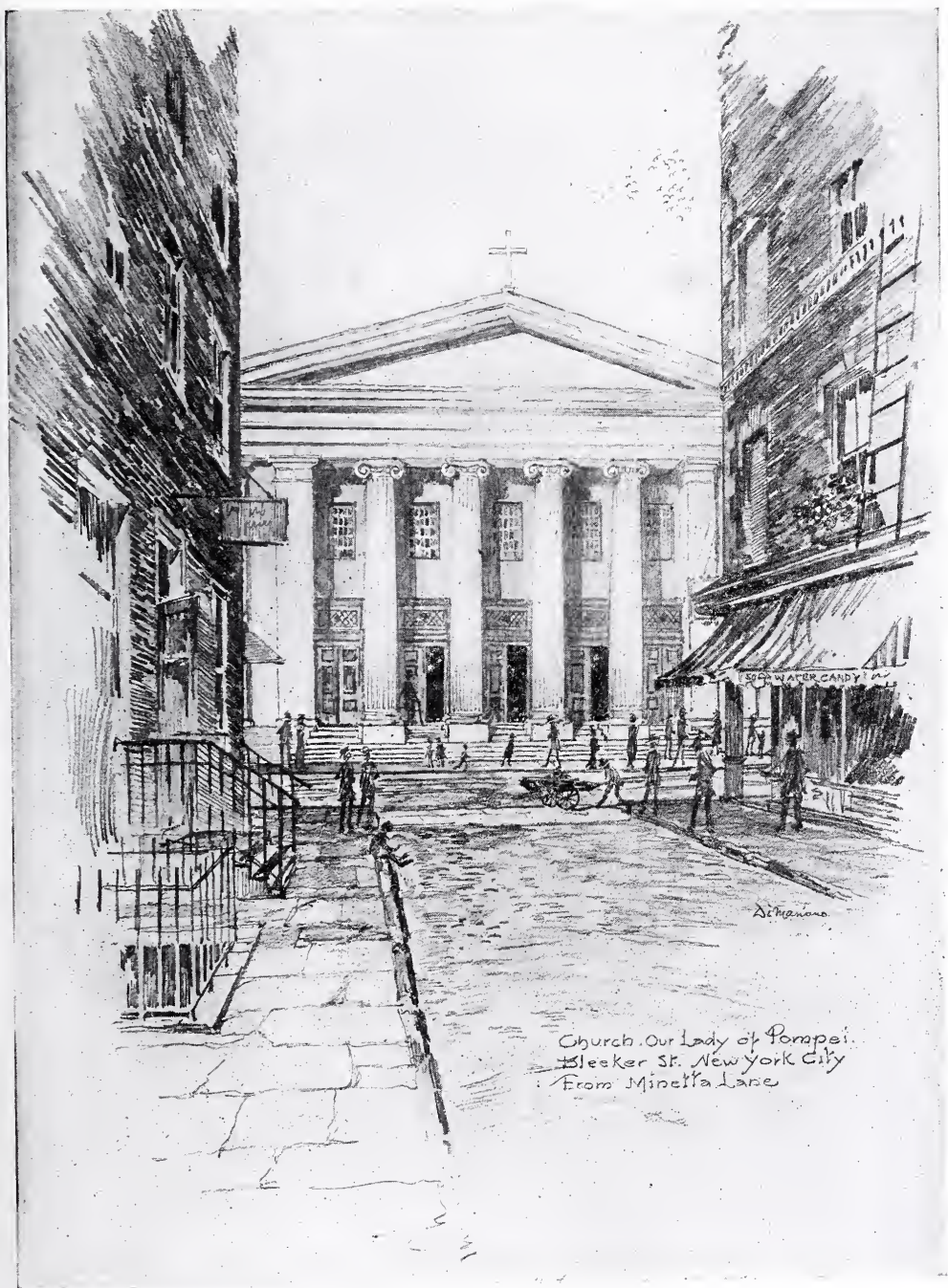

Church, Our Lady of Pompei,  
Bleecker St., New York City  
From Minetta Lane



(Washington's first headquarter 1776)





CITY HALL - NEW YORK

DRAWING BY JOHN DI MARIANO.



DRAWING BY JOHN DI MARIANO



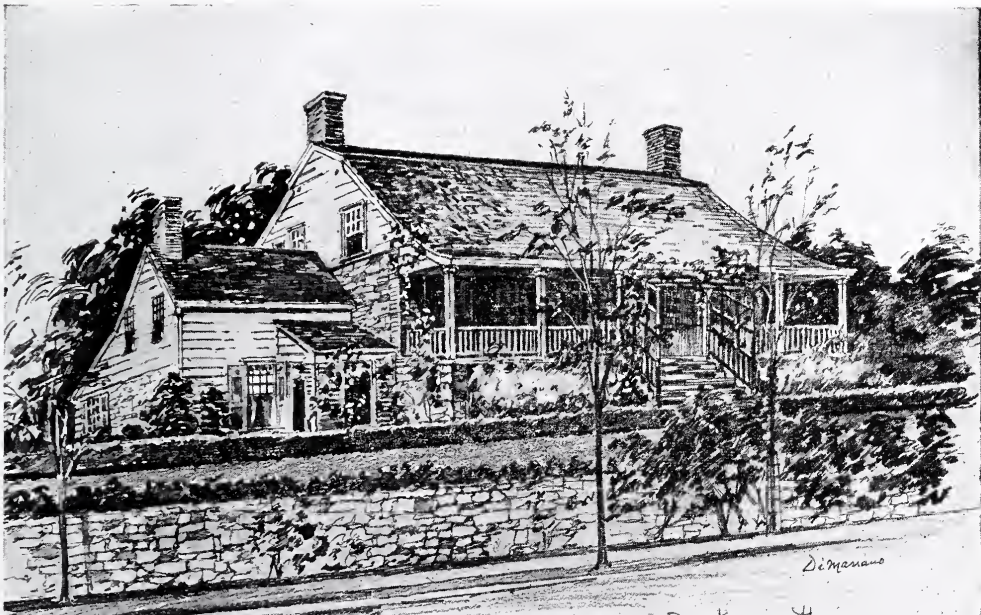

Dyckman House  
Broadway to 204 St.  
New York City



Military Hut of  
the Revolution.  
Reconstructed of  
old material of the Revolution  
Dyckman House Park 204 St. & 21st Ave  
New York

## THE ARCHITECT'S LIBRARY



### PROF. WARREN'S LECTURES

THE FOUNDATIONS OF CLASSIC ARCHITECTURE. By Herbert Langford Warren. Illustrated from Documents and Original Drawings; 10 x 7½ inches, 349 pp. and index. New York: The Macmillan Co.

**T**HIS volume deserves to become one of the standard works of an architect's library. Its searching survey of the field of the architecture of antiquity; its keen analysis of the principles of Greek art, came at an opportune moment in our fast evolving architectural development. It may be surmised that we are on the eve of another great building era, similar to the one that arrived with the twentieth century, when, all over the country, a great civic, public type of architecture was set up, under the leadership of McKim, Cass Gilbert, Hastings, Post, Burnham, Coolidge, Peabody. The approaching development is bound to continue the evolution of form and style which the past one began. This evolution seems to have lagged somewhat during the last decade, since when the enthusiasm for our monumental architecture has been largely transferred to our domestic and small town types.

In the approaching development it is likely that there will be an appraisal of our monumental types of design, even though it may not throw much new light upon them. In this period immediately

following the war all fields of activity are being analyzed—often with little result, the process being sometimes a mere restlessness that is noted all over the world, which pervades all classes of people. At any rate, as long as we stick to neo-classic and Renaissance forms for monumental buildings, there is bound to be impatience and attack on existing methods. To meet this attack—whether within the profession or outside it, from the public, as in the recent episode of the onslaught in both press and magazine upon the design of the Victory Arch in New York—it may do no harm to understand fully the bases of Greek design, as set forth with such extraordinary clearness and imagination by the late Professor Warren. In fact, as one reads the book, one quickly arrives at the sensation that his mind is being suddenly refreshed after having become drowsy through viewing the constant procession of mechanical and perfunctory designs of the orders that meets his eye as he walks the streets of American cities. When one is brought face to face, even through the pages of a book, with the magnificent pageant of the ancient art of the eastern Mediterranean Sea, its splendid power, its exalted geometry, its perfect form, its sunlit color and decoration, its supreme union of simple purity with sensuous richness; it is as if, after passing a



winter of cold storage and canned products, one had gone out into the orchard in full summer, and picked the real fruit from the branches. Even though such an experience may produce no direct useful result, it is well worth while. Besides, it may lead to the opinion that our monumental architecture, however perfect it may be in respect to planning, is not quite abreast of our minor and domestic architecture in the matter of elevations.

Professor Warren's book goes to the heart of architecture. It is thus of greater value than a mere treatise on ancient art. Incidentally, it makes less serious the old controversy of Gothic vs. Renaissance, going beyond the arguments of both parties until they appear to be traveling in the same direction; but along roads on the opposite sides of a valley, and, not seeing clearly the lay of the land, each shouting across that the others are on the wrong road. In Warren's eyes, though he does not mention it, a good deal, but by no means all, of Renaissance is to be condemned, not because it is not Gothic, but because it is bad Greek.

More specifically, the book was in manuscript form at the time of Warren's death in 1917. Professor Fiske Kimball, who was one of his students, undertook the work of making it ready for the publisher. He has performed the task admirably, though we may feel that he has chosen the splendid series of illustrations somewhat too technically and architecturally—as documents mostly. One would like to see a few more pictures of sculpture, more of the beautifully profiled drawings such as are found in d'Espouy and in the works of the first English searchers on the Acropolis, which would have infused a little more of the life and light and beauty and atmosphere of ancient art into the illustrations, as they are so infused into the author's text. Also, the chapters might have been better divided.

The work is of fine scholarship, where, in the ripe experience of the practising architect puts an unerring finger on the few mistakes of the scholar-archæologists that arise from their not realizing exactly how buildings are built and how

the minds of builders work when designing them. But it is also more than that, it is the thought of a man who was familiar with all the arts and who viewed them in a perspective of a distinguished humanistic culture. He expresses himself in a simple, clear, at times vivid, style, recalling the lucid French writings on architecture. His pages are rich in word pictures of ancient splendor, in paragraphs on the dramatic settings of the temples of Luxor and Karnak and their surroundings, of the pageant along the banks of the Nile from the first cataract to the sea, the river approach and entrance into Babylon and the climax of it all on the rock of the Acropolis.

A contribution to the literature of architecture is Warren's analysis of the Doric and Ionic order. It makes much contemporary design appear half thought out. If orders are to be continued in architecture, at least their spirit should be grasped, even if their letter is not followed. This is one point, certainly, where recent progress can be questioned. How placid, colorless, cold, mechanical—symbols of a bookish purism—are some of our latest colonnades beside the bold, richly decorated, well colored, sunlit Corinthian design of Stanford White's of the Knickerbocker Trust Company on Fifth Avenue!

Professor Warren ranks with the great teachers of the history and principles of architecture. I suppose his bold vision disconcerts somewhat the more prosaic, clerically minded race of scholars, easily upset as they are over any slight disregard of the rules, so occupied over minute distinctions as to facts, that they fear to draw conclusions. In one of his characteristic letters Theodore Roosevelt has roundly whacked this type of historian, whose duty—and a most necessary one, of course—is to look after the correspondence, keep the files and catalogue the library. Roosevelt objects to such historians in the role of patronizing the masters—the Parkmans, the MacCauleys. For, he says in effect, no matter how great the need for exact research and statistics, only the master mind can present them in their true value. He alone can picture history in a light which stimulates inspira-

tion and ideas; which, after all, is what one wants. This can be done and still keep within the rules of evidence. In Professor Warren's work there is little that the most critical scholarship could question. JOHN TAYLOR BOYD, JR.

**MORE SMALL ITALIAN VILLAS AND FARM-HOUSES.** By Guy Lowell. New York: The Architectural Book Publishing Company.

The present volume carries on the good work started by Mr. Lowell in a preceding volume of a similar subject. During the war the author, as an officer in the American Red Cross, spent much of his time in Palladio's country around Vicenza and was afforded unusual opportunities to visit and photograph many of the lesser known buildings of the Palladian tradition. In the short introductory text the descent of much of our American Colonial architecture is traced back through Inigo Jones and his successors in England directly to Palladio, whose architectural principles for the adaptation of classic motives to contemporary architecture formed the basis for Georgian architecture in England and for our own Georgian Colonial and Early Federal architecture. A study of the photographs is interesting and illuminating with regard to the first sources of our Colonial work, and the fact that Palladio's book was used in this country in the actual design of certain buildings, notably by Thomas Jefferson who did not hesitate to reproduce almost exactly some of the designs of the sixteenth century architect, gives us in our later eighteenth and nineteenth century architecture a direct contact with this Palladian work without reference to English translations of the form. These examples also show the flexibility in handling which, although possible, is so frequently ignored in our modern building along Colonial lines.

In addition to this close connection with the strongest architectural tradition in America, the book revivifies for us the country house life of sixteenth and seventeenth century Italy, when the yearly exodus from the city to the country was as marked a characteristic in

the social calendar of that day as it is in that of the present. Although the villas themselves emphasize this similarity of extravagant country pleasures on the part of the rich, the farmhouses present an equally sharp contrast between the positions of the peasant farmer of now.

The many views of the buildings intensify our desire that it might be possible to study their planning with equal ease. Numerous delightful sketches by Edgar I. Williams and Harold R. Shurtleff illustrate points of the text.

C. O. C.

**THE COLONIAL ARCHITECTURE OF SALEM.**

By Frank Cousins and Phil M. Riley. Boston: Little, Brown & Co.

The architectural photographs of colonial details by Frank Cousins are so well known as to need no introduction to readers of this magazine, and to many the fact that this recent book is copiously illustrated by Mr. Cousins will recommend it at once to consideration.

The text, written in a discursive style, contains much information with regard to early building in Salem. It follows the development of domestic building through the seventeenth and eighteenth centuries and into the first decades of the nineteenth, when much of the most distinguished and distinctive building was done. The earlier peaked roof houses come in first for consideration, followed by those with gambrels of various forms. The tall, square, box-like, three-story houses next are taken up; and the latter half of the book is devoted to the exterior and interior details, which are so markedly of high quality in Salem. The text and illustrations synchronize throughout the book and their coordination is of assistance in reference. Much of the text is occupied with references and historical data of greater interest to the antiquarian than to the architect, who might be inclined to demand a more definitely constructive criticism of the fine old material; but this he can supply for himself, through familiarity with the eminently pleasing buildings illustrated in the hundred odd plates.

C. O. C.



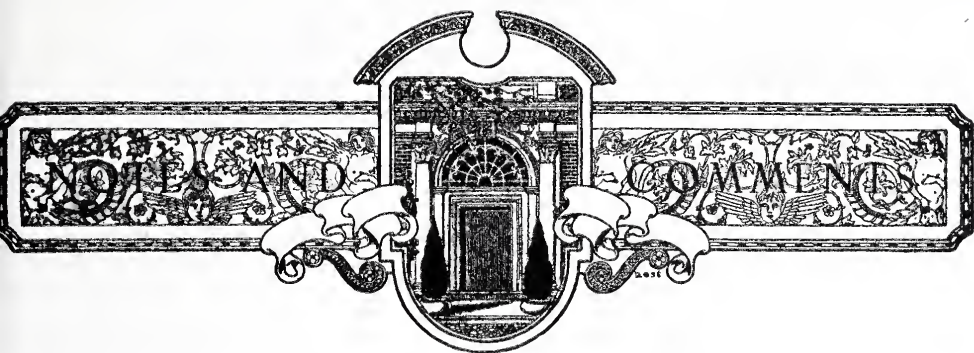

The American Legion is to erect in San Francisco a monumental group of buildings in memory of the men and women—soldiers, sailors and civilians—who died that democracy might live. This monument in commemoration of the victory of democracy will be a nurturing place for all the highest ideals of a free people. It will be a home of the fine arts—painting, poetry, sculpture, music and architecture.

The faculty and students of the California School of Fine Arts, in this memorial, will be generously provided with facilities of study. Will they be worthy of it? This year your student body was awarded six out of ten of all the honors available to art students throughout the country. Next year you should aim to get seven out of ten, for California is a source of inspiration to art.

In the War Memorial the Art Association will have its galleries, supplementing the ateliers of the California School of Fine Arts. Students from all the world will, in time, seek this center for instruction—that is, if nature, temperament and determination are no less strong with us than were these characteristics with the Egyptians, Greeks, Italians and other predecessors of present-day ideals of civilization, order and art.

So far as the students here tonight, and the faculty, too, for that matter, are concerned, it must be remembered that success in any vocation means patient, unending plodding. There is no short cut. Impressionist, cubist, fads are entertaining, but usually are uninstructional and detrimental to healthy artistic development. The student must study the methods of

the old masters, not to copy them, but to seek inspiration.

Michelangelo, Rubens, Rembrandt, Raphael, Leonardo, Velasquez—all the masters were artisans as well as artists. Their work was complete to the last detail.

Can you match the incomparable finish of the winged Victory of Samothrace or the immortal sculptures of Phidias with the incomplete and unfinished works of Rodin?

#### Old Hardware from Philadelphia and Annapolis.

There is a fine individuality in the style of old Colonial hardware which adorns the historic homes of Philadelphia and of Annapolis. They possess a variety of quaint designs and decorative qualities, and the accompanying sketches, made from data collected by the architect, Charles S. Keefe, during little visits to these cities, show some of the many artistic shapes to which minor decorative features can be adapted. The old shutter hinge found in Philadelphia is of a naive, almost crude, type. The uneven surfaces and hand-wrought nail heads invest it, however, with unusual interest. The same is true of the shutter bolt from the same city, which is particularly noteworthy for its simple mechanism.

The shutters or blind fasteners are, on the other hand, more elaborate in design and craftsmanship. Frequently the lower portion was wrought into a tapered scroll, circular in section, which gives the whole an effect of great delicacy and airiness, also producing a shadow of decorative charm on the wall behind; while the upper part was hammered out in the shape of the bowl of a spoon, the slight concavity of which presents a more interesting sur-

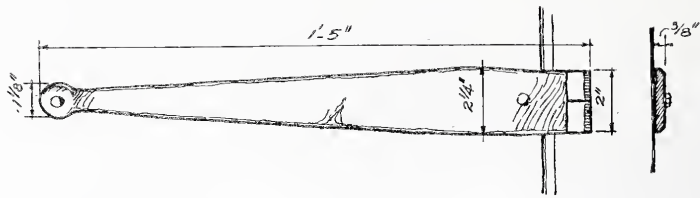

· SHUTTER · HINGE ·  
· FROM · PHILADELPHIA ·

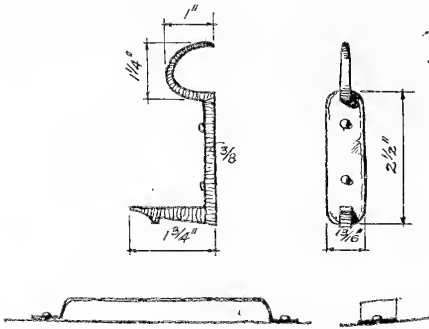

· SHUTTER · HOOK ·  
· FROM · ANNAPOLIS ·

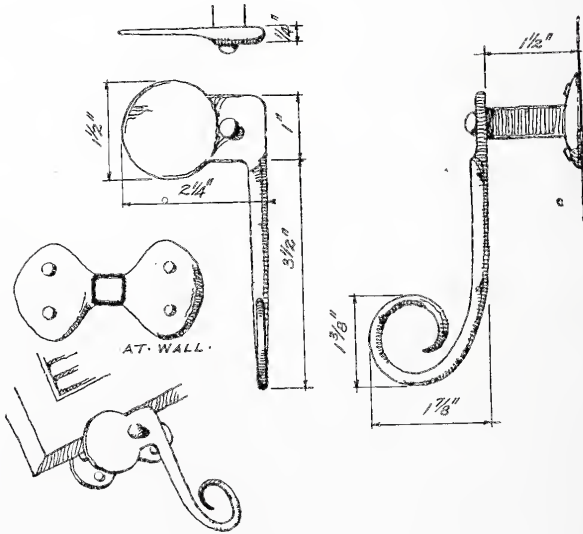

· BLIND · FASTENER ·  
ON · OLD · HOUSE · NEAR · CAPITOL ·  
· ANNAPOLIS · M · D ·



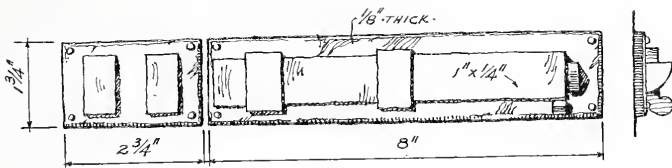

· SHUTTER · BOLT ·  
 · FROM · AN · OLD · HOUSE ·  
 · IN · PHILADELPHIA · NOW ·  
 · DEMOLISHED ·

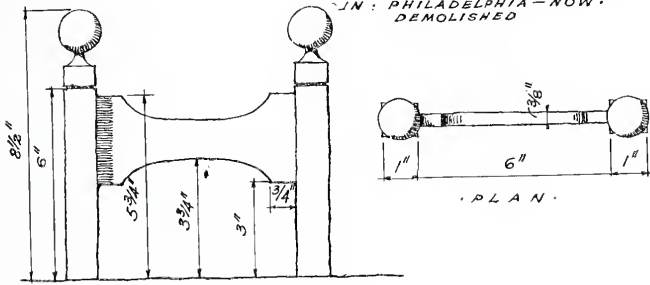

· FOOT · SCRAPER ·  
 · FROM · HOUSE · ON · SPRUCE · E · 57 ST ·  
 · PHILADELPHIA ·

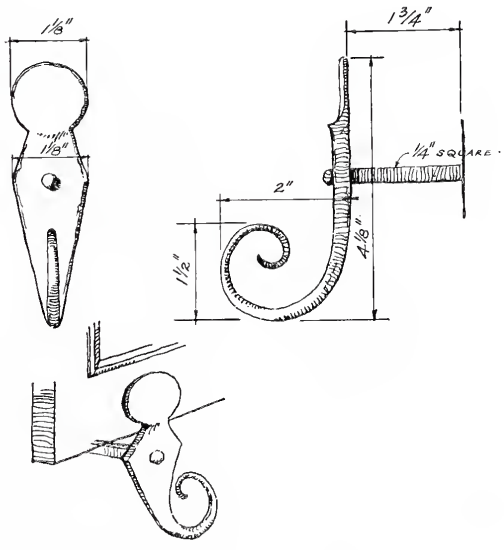

· BLIND · FASTENER ·  
 · FOUND · IN · PHILADELPHIA ·

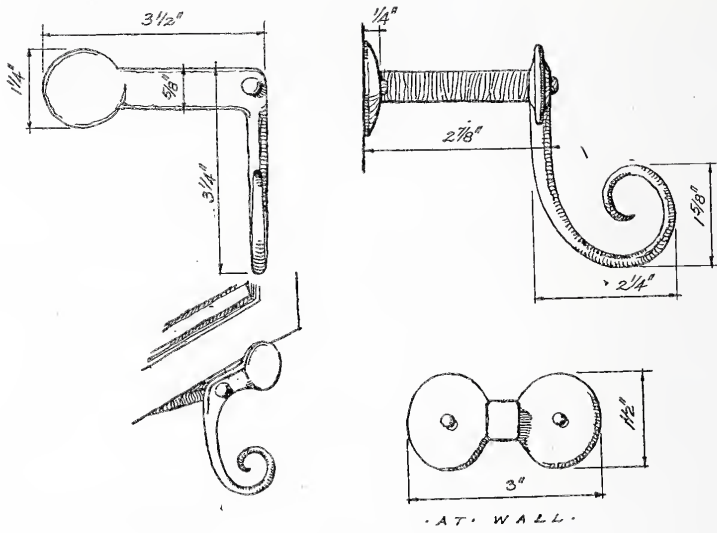

· BLIND · FASTENER ·  
· FOUND · ON · ANNAPOLIS · HOUSE ·

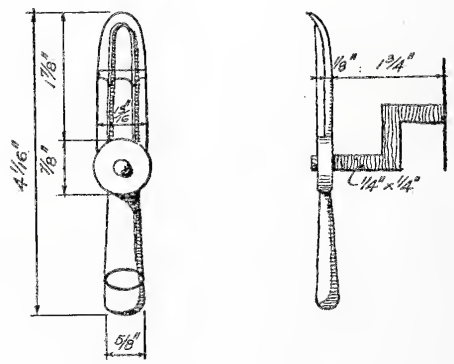

· BLIND · FASTENER ·  
· FROM · ANNAPOLIS ·



face than is found on the usual flat wrought work of today.

The other fastener, being of the vertical type, would be quite uninteresting were it not for the singular way in which it is modeled. The upper half is grooved, while the lower half has been wrought into a sort of pendant which is elliptical in section.

The foot scraper has exceptionally sturdy and uncompromising lines, decidedly different in character from its contemporaries, the quaintly scrolled and twisted type. This specimen, nevertheless, bespeaks an excellent sense of proportion and delicacy, combined with the rigidity reminiscent of the fine old Quaker spirit.

The shutter hook and catch found in Annapolis are worth of notice; here use and attractiveness are combined. The catch is only a strip of sheet metal which gives under the pressure of the hook until the latter slips past and is caught. At the top of the hook is a scythe-like handle for its release.

These examples are typical of the charm and distinction of early American craftsmanship.

VERNA COOK SALOMONSKY.

Innate paternal regard rarely permits the sculptor or painter to cast it adrift on the sea of anonymity. The architect, apparently esteeming sentiment incompatible with an unemotional art, abandons his intellectual progeny by the roadside, without tag or identifying mark. The desire to trace a cause or reason for such action, and to propose another course, is the motive of this article.

**The Architect's  
Signature on  
His Work**

A ray of light was recently cast upon the subject in the writer's mind while reading the introduction to Adolph Lange's "Dictionnaire des Architectes Francais" (Paris, 1872). This erudite work imparts many interesting and obscure facts encountered in patient and wide research, relative to the practice of architecture in pre-Renaissance days in France; it also treats of emoluments and strange customs affecting the welfare of its practitioners. Incidentally he treats of the seals with which their deeds and contracts were ratified in lieu of signature, the art of writing previous to the latter half of the fifteenth century be-

ing practiced almost exclusively by clerks and notaries.

Sixty-nine of these seals are reproduced in the work in line engraving from wax impressions extant on ancient documents, dating as far back as the early part of the twelfth century. From the study of these decorative emblems the thought matured, to the effect that they might prove the basis for a solution to a much mooted question—the signed building. The suggestion latent in these devices may become sufficiently potent to reverse the existing attitude, and induce the architect to identify himself directly with his work, in a manner less open to criticism than the methods occasionally resorted to.

The architect has long been the subject for unjust professional discrimination, inasmuch as his name does not figure as a matter of course upon his work. The signature of the originator in other arts is recognized as his title to the inception of the idea developed. If we judge the view of the architectural profession by the procedure of the majority, we must assume that conviction is almost unanimously in favor of anonymity. In spite of the overwhelming evidence of custom, we have equally voluminous proof that a voluntary disassociation of the individual from his work in any practice of the creative arts is contrary to instinct and temperament.

The attitude of the layman to the signed work by the painter or sculptor is that it is an essential item necessary to ensure the maximum value of the original; but he instinctively views the name of the architect carved on the base of the building with a mixed feeling of distaste and distrust, while recognizing the right of every originator to be identified with his work.

The question of the signed building is replete with complexities. An examination of the relative merits of circumstances and prejudices might enlighten us as to whether the principle errs against the code of good taste, or whether the fashion in which the name has figured is to blame.

The fact is indisputable that we regard the signature on a work of art at a widely separate angle from that on an edifice; therefore it is necessary to discover what a signature implies when affixed to a painting, and in what essential it differs when figuring on a building, where it surprises us unpleasantly.

In a painting, the source of sentimental prestige is mainly contained in handicraft; that is to say, we attach the greater importance to the fact that the work is the

record by the artist's own hand of his mental conception. Workmanship or technique embodies all those peculiarities of expression or treatment inseparably connected with the personality of the individual, which cannot be spontaneously reproduced or transmitted by another. Were we to accept this type of handicraft as the standard for accordng architectural credit, to the same extent as we recognize it in painting, the architect would at once be put out of court in the matter of recognition.

The problem would seem to resolve itself into two considerations, which concern the relative importance of the imaginative and executive elements in painting, for instance, on the one hand, and in architecture on the other. In the case of painting, imaginative power is entirely dependent for its realization on the fashion in which selected scenic data in nature are recorded by the artist's hand, reflecting through manual interpretation the angles of temperament. In architecture, a masterly conception might be equally well realized in a dozen or more localities by interchangeable subordinates; therefore the factor of production by the originator, which is vital in the painting, is negligible in architectural work.

Is it not possible that our taste is offended more by the manner in which the architect's name is sometimes affixed to his building than by its presence thereon? Precedent causes us to expect that the word or inscription figuring on a member of an edifice shall convey pertinent information—its name, the purpose of its chambers or halls, or the motive responsible for its erection. When we read an inscription placed more or less prominently on the base of a building to the effect that a certain person is its architect, we instinctively classify him within the category of what might be described as the domestic professions, whose members advertise their calling by shingle or plate, to attract the patronage of stray clients. As commercial methods of this description are considered unethical in the aesthetic profession, we instinctively feel that a professional principle has been sacrificed for pecuniary ends.

In the upper west section of New York City a number of autographed apartment houses can be found for reference as test cases for the reader's sensibility. These signatures impress one unfavorably by their undue prominence. Yet one often longs to

know the authorship of an architectural masterpiece, to pay homage to the name of the artist whose great gift has found expression in perfect harmony and grace. Such incidents lead us to believe that, to attain the full complement of esthetic enjoyment, we desire a human association in connection with a great work.

The foregoing considerations, which had occurred to the writer at various times, grouped themselves after an examination of the seals reproduced in Lange's work. The designers of seals, medals and coins during the *moyen-age* command our admiration by the utmost decorative science in adjusting the motif to the space. The majority of these architects' seals are beautiful emblems, appropriate, ingenious and laden with suggestion. Could they be translated into other media, such as stone, wood or clay, they would adorn the surface surrounding them. Were we to discover such an emblem carved in low relief in some spot of secondary prominence, our interest would register satisfaction, in that our introduction to the architectural author had been effected in such pleasant fashion. In brick or stucco wall, an ingenious faience insert well placed challenges our inspection and reveals by its polychrome symbols that it is the architect's signature of his work, impressing his mark thereon with a touch of beautiful and welcome color. These decorative architectural signatures could, and should, be protected by registration in the interest both of the owner and the public. Many of the ancient designs conform to a set plan, which consists of an inner circle in which is placed the shield or emblems and an outer circle holding the name, frequently accompanied by the word "seal" (seal); in other cases the owner's initials figure.

For many generations the architect has suffered the anonymous professional designation of the domestic retainer, being referred to as "my architect"; a practice not in accord with the dignity of a creative profession. It is not customary to refer to "my portrait painter," possibly for the reason that the identity of the producer is the chief credential of value; in fact, in many instances the subject's identity is quite subordinate to that of the painter. A corresponding condition should exist with regard to modern architectural works of equivalent merit.

The attitude of the daily press to the profession is an interesting reflection of



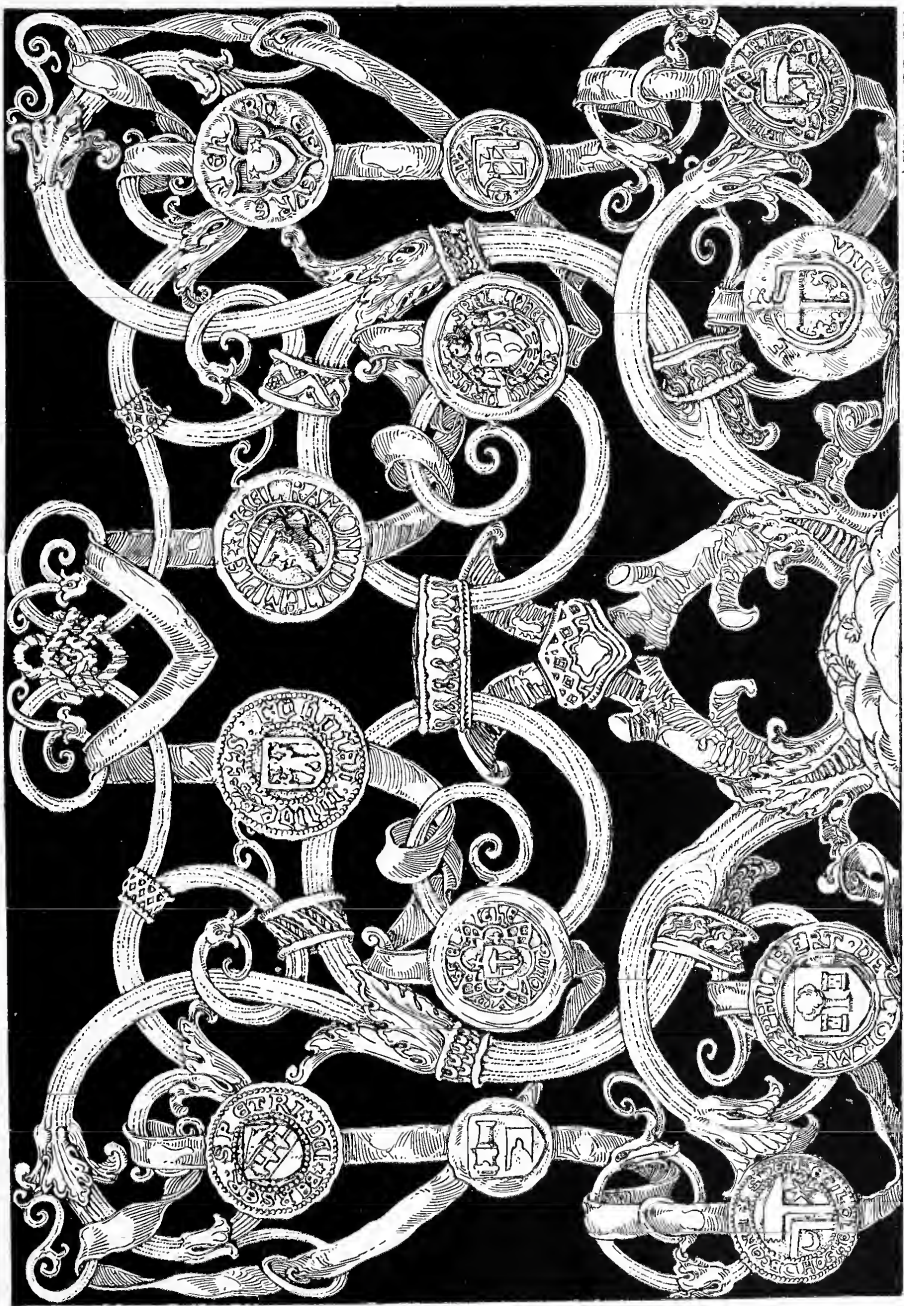

LEON V. SOLON.

EXAMPLE OF BUILDERS' AND ARCHITECTS' SEALS OF MEDIEVAL AND RENAISSANCE DATE.

the apathy of the general public towards the subject. A certain amount of prominence was recently given to the dedication of a church of considerable architectural pretension. Space was consumed in describing its interior and the ceremony, and in enumerating the notabilities attending the consecration, but the architect's name was omitted by the majority of the great dailies. Had their critics, in reviewing a musical recital, described the scene, the music and the occupants of the boxes, but forgotten the name of the virtuoso, there is little doubt that such an omission would have provoked the comment of each reader.

In these days of American architectural naissance, many buildings arise that should carry the names of their authors to posterity. The main difficulty has been to determine the exact manner in which this could be done, as the architect had to choose between loss of identity with his work and identification with it in a fashion that reflected on his good taste and professional modesty.

The present writer feels that this suggestion, retrieved from a practice of ancient times, may prove of use in enabling the architect to come into possession of his own.

LEON V. SOLON.





September

The

1920

# ARCHITECTURAL RECORD



*Published in New York*  
*35¢ a Copy \$ 3.00 a Year*





# Bishopric Suggestions:

Showing Use Under Thatched Roof and Throughout Exterior and Interior  
 Send for Special Loose-Leaf Portfolio for Architects  
**THE BISHOPRIC MANUFACTURING CO.**  
 102 Este Avenue, Cincinnati, O.

**BISHOPRIC SHEATHING**—Strengthening, insulating, sound-deadening, weather-proofing unit; for exterior walls, sub-flooring and sub-roofing.  
**BISHOPRIC STUCCO AND PLASTER BASE**—Interlocking dovetailed key, insulating and waterproofing unit; creosote treated and not treated.

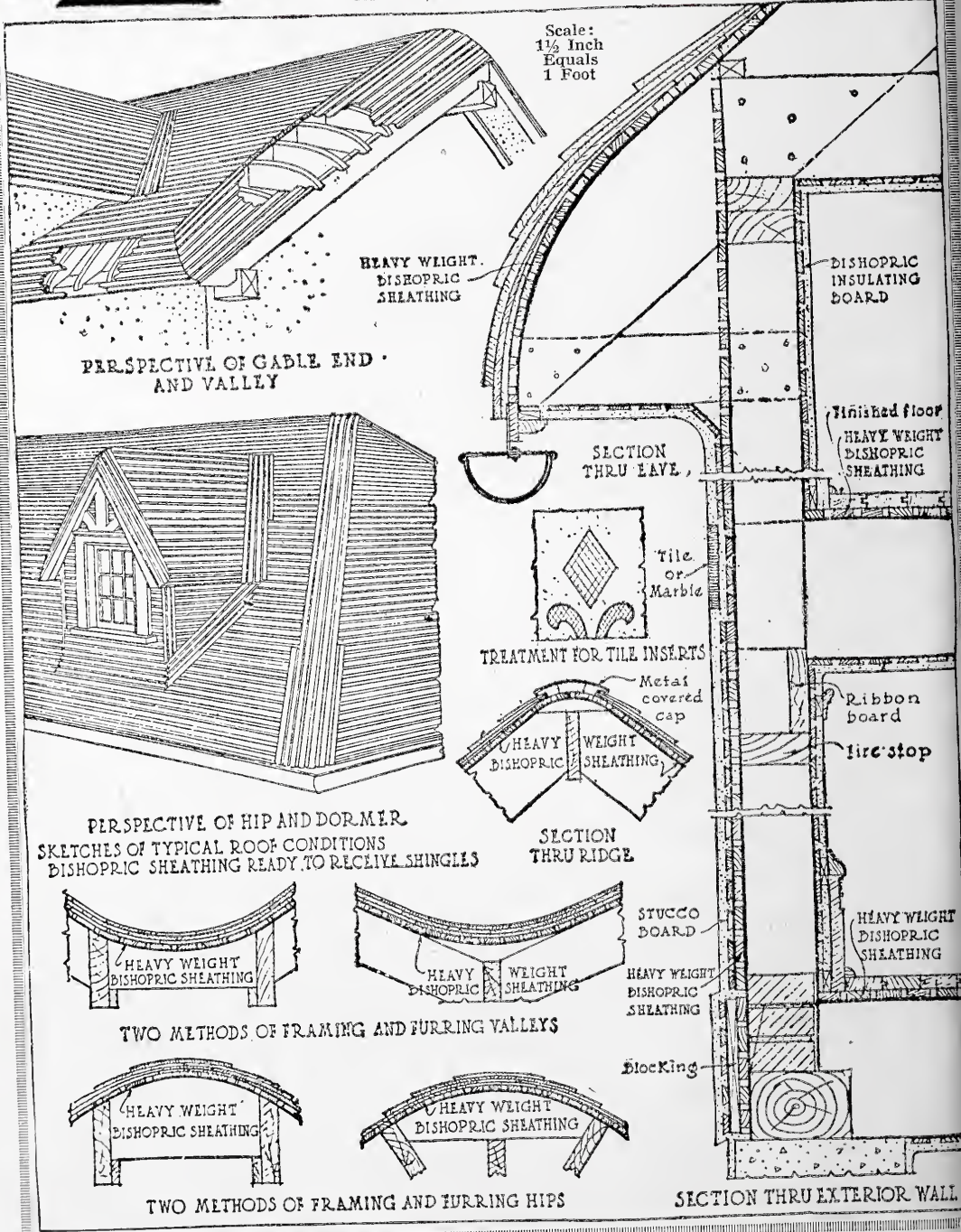



# THE ARCHITECTURAL RECORD



Vol. XLVIII. No. 3

SEPTEMBER, 1920

Serial No. 264

Editor: MICHAEL A. MIKKELSEN

Contributing Editor: HERBERT CROLY

Business Manager: J. A. OAKLEY

	PAGE
COVER - Design for Faience Garden Decoration <i>By Leon V. Solon</i>	
PIDGEON HILL, Residence of Meredith Hare, Esq., Huntington, L. I.: Charles A. Platt, Architect <i>By Herbert Croly</i>	179
THE NEW YORK ZONING RESOLUTION AND ITS INFLUENCE UPON DESIGN. <i>By John Taylor Boyd, Jr.</i>	193
THE PROPOSED VICTORY BRIDGE OVER THE HUDSON, Between New York City and Weehawken: Alfred C. Bossom, Architect <i>By Robert Imlay</i>	219
ENGLISH ARCHITECTURAL DECORATION. Part XV <sup>3</sup> . The Adam Period (Continued) <i>By Albert E. Bullock</i>	225
WINNING DESIGNS IN THE COMPETITION FOR THE FELLOWSHIP IN ARCHITECTURE OF THE AMERICAN ACADEMY IN ROME	236
SOME PRINCIPLES OF SMALL HOUSE DESIGN. Part IX. Interiors (Continued) <i>By John Taylor Boyd, Jr.</i>	243

Yearly Subscription: United States, \$3.00; Foreign, \$4.00; Single Copies, 35 cents. Copyright, 1920, by The Architectural Record Co. All rights reserved. Member Audit Bureau of Circulation.

PUBLISHED MONTHLY BY

THE ARCHITECTURAL RECORD COMPANY

115-119 WEST FORTIETH STREET, NEW YORK

T. S. MORGAN, Pres.    W. D. HADSELL, Vice-Pres.    E. S. DODGE, Vice-Pres.    J. W. FRANK, Sec'y-Treas.



FRONT PORCH — "PIDGEON HILL," RESIDENCE OF MEREDITH HARE, ESQ., HUNTINGTON, L. I. CHARLES A. PLATT, ARCHITECT.



# THE ARCHITECTURAL RECORD

VOLUME XLVIII



NUMBER III

SEPTEMBER, 1920

## PIGEON HILL RESIDENCE of MEREDITH HARE, Esq.

*Huntington, L.I. ~ Charles A. Platt, Architect*

By  
HERBERT CROLY

IT was something less than twenty years ago that well-to-do residents of New York began to build new houses on Long Island, within easy commuting distance of the city. Since then the district on Long Island between twenty and forty miles from the Pennsylvania Station has steadily increased in popularity. Improvements in transit by motor and the construction of the tunnels under the East River have had much to do with this increase in popularity, but it is also traceable to the desire of New Yorkers for country houses, at a convenient distance from the city, which were available for residence throughout the whole

of the year and that afforded the opportunity not only for the usual country games and sports, but for gardening, farming, the raising of stock and the other less frivolous occupations of rural life. A much more wholesome attitude towards the country has prompted the building of the Long Island houses than the attitude which prompted the earlier building of villas, sometimes by the same families, either at Newport or anywhere else on the coast.

This more wholesome attitude is expressed in the character and the design of the houses. There are comparatively few examples on Long Island of the

pompous formality and the palatial pretentiousness which characterized so many houses erected by rich Americans during the last decade of the nineteenth century. More and more the builders of the new houses have started with their minds fastened on the kind of residence which an English country gentleman would wish rather than a seventeenth century nobleman; and this comparative unpretentiousness of outlook has released the architects of these buildings from the necessity of complying with many embarrassing and paralyzing demands. The newer houses have usually remained formal, which is a good thing, because sound architectural design requires a large infusion of formality; but their avoidance of mere informality and picturesqueness has not stood in the way of a great gain in individuality, in homeliness, and in domestic propriety. In many cases the houses bespeak a living relationship with the people who occupy them; and the people who occupy them possess standards and interests which are adapted to sincere, beautiful and significant expression. When the history of American domestic architecture of the existing generation comes to be written, the Long Island houses, particularly those built during the past twelve or thirteen years, will form the best and the richest material which the historian will have to use.

Long Island before the advent of the modern architectural movement possessed the advantage of a peculiar species of domestic design. The usual farmhouse of that region was not clap-boarded or sheathed but was shingled; and the shingles were somewhat larger in size than those used elsewhere, somewhat thicker and were painted white. Since in a wooden building so much of the effect depends upon the surface, the texture, and the delineation of the material, these Long Island shingles, super-imposed upon the generally good lines and appropriate details of the early farmhouse, created perhaps the most interesting type of small residence, for the use of the yeoman farmer, which was erected in this country. It certainly created a type which was more flexible than the New England farm-

house, and whose elements could be developed and varied without necessarily losing the merits of the original design. It is no wonder, consequently, that during the revival of domestic building that has recently taken place on Long Island the builders have frequently altered and enlarged the old farmhouses. In many cases they have succeeded in converting them from the residences of yeomen farmers into the residences of gentlemen farmers, without any falsification of the original type.

In some few instances, however, architects have perpetuated the type not merely in alterations but in an entirely new building. Such is the case with the house of Mr. Meredith Hare at Huntington, Long Island, designed by Charles A. Platt. The Hare residence is an excellent example of the very best qualities which are now characterizing American domestic architecture. It combines in a very happy way spaciousness with economy. Architects always find it difficult to design a house which look ample enough to form the background for a liberal life without becoming wasteful of space; but in Mr. Hare's house, Mr. Platt has succeeded in excluding all superfluities while retaining an atmosphere of generosity and abundance. He has kept the scale and the general appearance of a Long Island farmhouse, which formed, of course, the background for anything but a spacious life; and without departing from the unpretentious simplicity essential to the type, he has designed a building which forms an entirely appropriate residence for people with leisure who prefer to devote the time, no longer occupied with the struggle for existence, to cultivating the arts and amenities of life. This house was designed, and successfully designed, for the purpose of providing an appropriate setting for the life of a particular family. When a nation educates architects who are capable of creating propriety of relationship between buildings and lives, and when the life which is expressed in the building possesses sincerity, distinction and value, it is by way of creating a domestic architecture which will endure, and deserve to endure, in the aes-





FRONT ELEVATION—"PIDGEON HILL," RESIDENCE OF MEREDITH HARE, ESQ., HUNTINGTON, L. I. CHARLES A. PLATT, ARCHITECT.

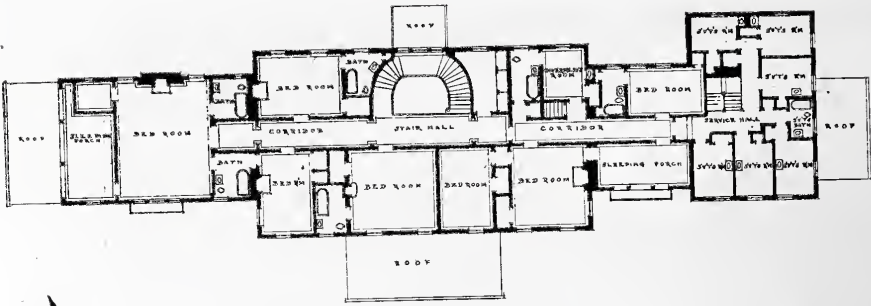

SECOND FLOOR PLAN



Scale of Measure  
 0 5 10 15 20 25

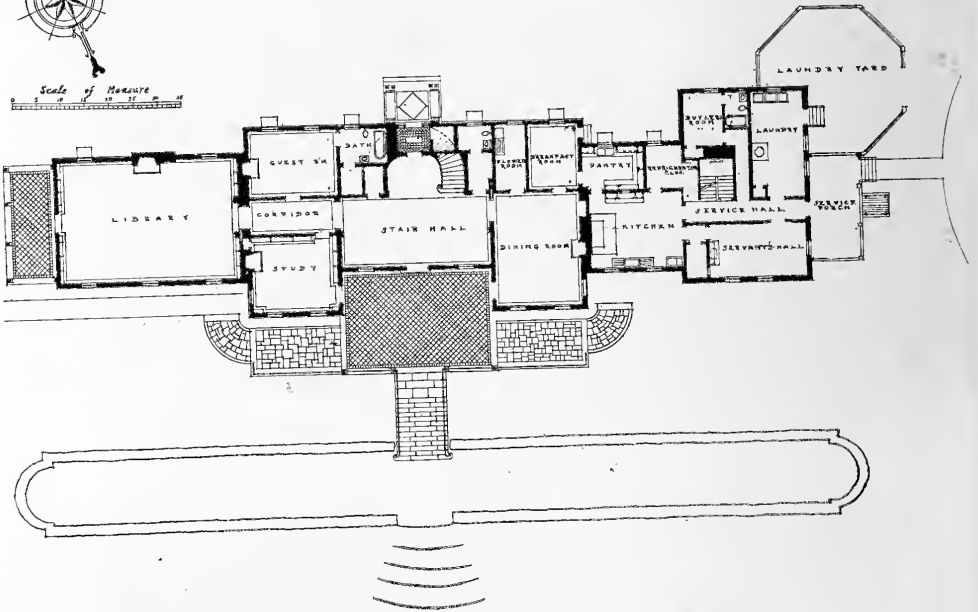

FIRST FLOOR PLAN

FLOOR PLANS—"PIDGEON HILL," RESIDENCE OF MEREDITH HARE, ESQ., HUNTINGTON, L. I. CHARLES A. PLATT, ARCHITECT





GARDEN ELEVATION—"PIDGEON HILL," RESIDENCE OF MEREDITH HARE, ESQ.,  
 HUNTINGTON, L. I.  
 Charles A. Platt, Architect.

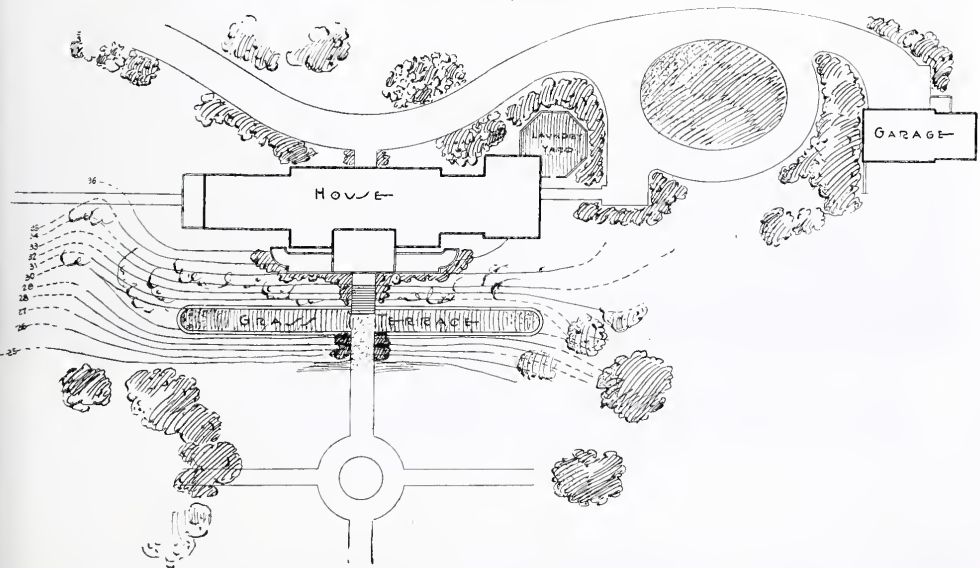

BLOCK PLAN—"PIDGEON HILL," RESIDENCE OF MEREDITH HARE, ESQ., HUNTINGTON, L. I.  
 Charles A. Platt, Architect.



DETAIL OF GARDEN ELEVATION—"PIDGEON HILL," RESIDENCE OF MERE-  
DITH HARE, ESQ., HUNTINGTON, L. I. CHARLES A. PLATT, ARCHITECT.





GARDEN ELEVATION—"PIDGEON HILL," RESIDENCE OF MEREDITH HARE, ESQ., HUNTINGTON, L. I. CHARLES A. PLATT, ARCHITECT.



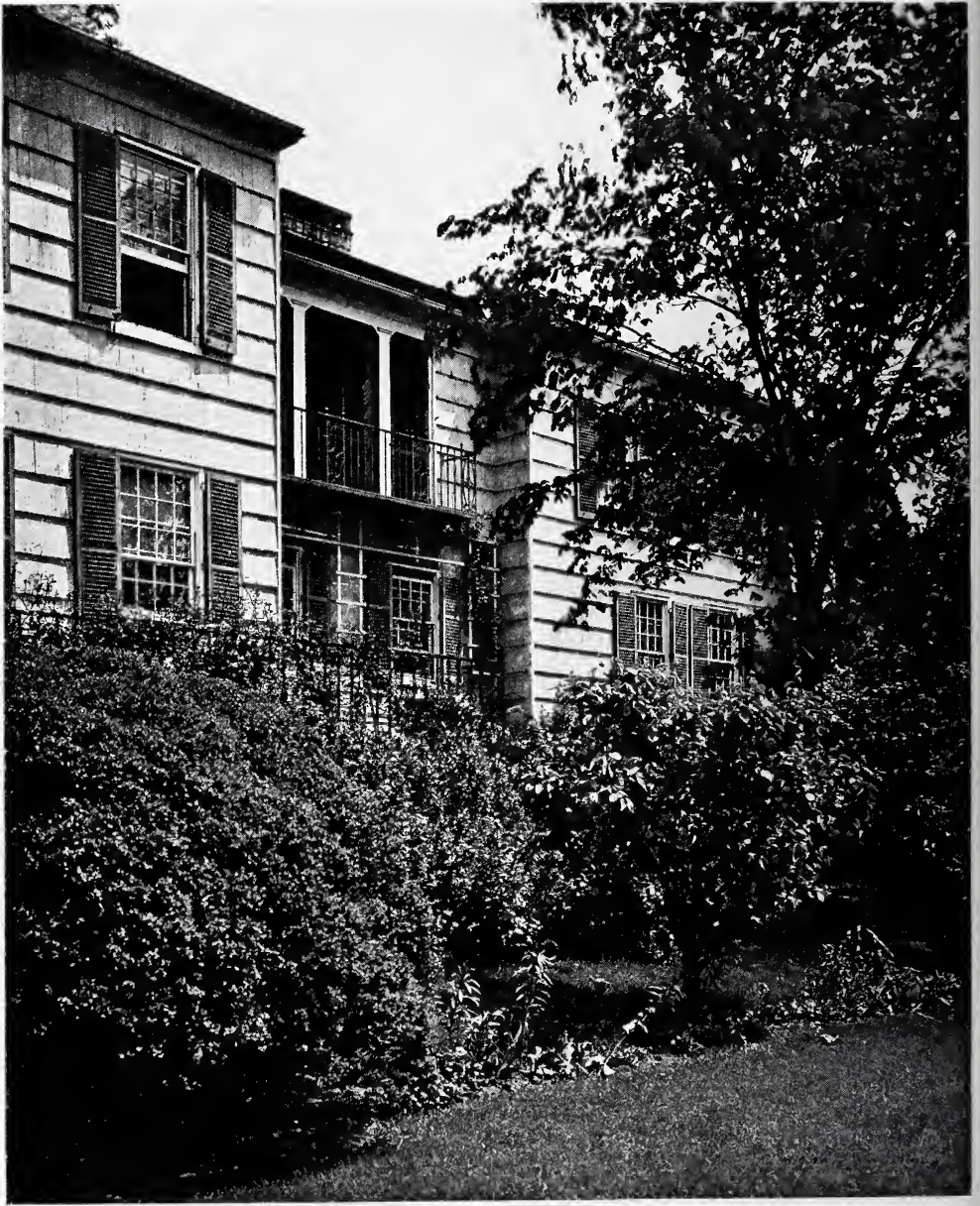

DETAIL OF GARDEN ELEVATION—"PIDGEON HILL," RESIDENCE OF MERE-  
DITH HARE, ESQ., HUNTINGTON, L. I. CHARLES A. PLATT, ARCHITECT.





EAST END OF TERRACE—"PIDGEON HILL," RESIDENCE OF MEREDITH HARE, ESQ., HUNTINGTON, L. I. CHARLES A. PLATT, ARCHITECT.

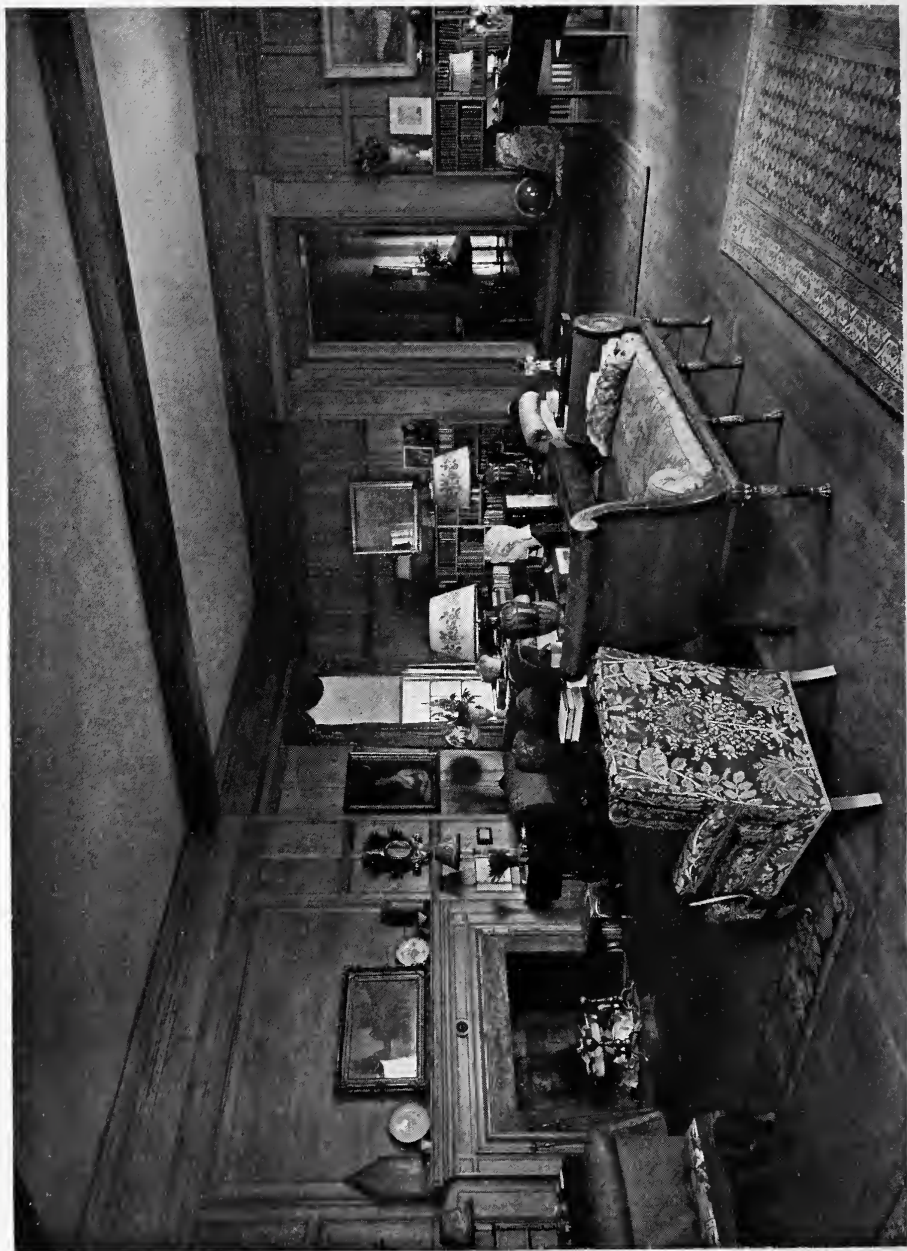

LIBRARY AND LIVING ROOM—"PIDGEON HILL," RESIDENCE OF MERE-  
DITH HARE, ESQ., HUNTINGTON, L. I. CHARLES A. PLATT, ARCHITECT.





DINING ROOM—"PIGDEON HILL," RESIDENCE OF MEREDITH HARE, ESQ., HUNTINGTON, L. I. CHARLES A. PLATT, ARCHITECT.



STAIR HALL—"PIDGEON HILL," RESIDENCE OF MEREDITH HARE,  
ESQ., HUNTINGTON, L. I. CHARLES A. PLATT, ARCHITECT.





A SECLUDED SPOT—"PIDGEON HILL," RESIDENCE OF MEREDITH HARE, ESQ., HUNTINGTON, L. I.  
Charles A. Pratt, Architect.

thetic consciousness of future Americans.

But, of course, a country house needs also another kind of propriety. It needs to fit not only the lives of its occupants, but also the particular site on which it is built. There are some residences, of which the Newport palaces form the perfect illustration, which can never become adapted to their sites. There are others, of which one finds so many examples in England, that, while they were not designed for their sites, have after a few hundred years grown into the landscape and now look as if they were always intended to be just where they are. Finally, there are others that only a few years after their erection look as if they had grown up on their site. They obtain their confirmation not from the weathering of time, but from their intimate relationship to the advantages and limitations of their immediate surroundings. Among the many American architects who have made a personal contribution to American domestic architecture

there is none who has so frequently succeeded in providing for his clients buildings which in a few years look as if they had been a very long time where they are. Mr. Hare's house does not look old yet. It is not old enough to settle down into its landscape with gentlemanly assurance and with complete self-possession. A few more years must elapse before it will become really mellow. But it is clearly becoming mellow very rapidly; and if the reader would like to know why, he can discover the reason by examining the plan and the lay-out in relation to the design. The scale and the dimensions of the house are nicely adjusted to a site which demanded intimacy and some informality of treatment. This the illustrations clearly show. What they cannot show so well is the success with which the porch of the house provides its residents with an introductory approach to that which is best worth looking at in the surrounding landscape.



ADDITION TO NEW YORK STOCK EXCHANGE  
—TROWBRIDGE & LIVINGSTON, ARCHITECTS.



# The NEW YORK ZONING RESOLUTION AND ITS INFLUENCE UPON DESIGN



*By John Taylor Boyd, Jr*

FOUR years' trial has proved the value of the New York Zoning Resolution of 1916. By adopting this measure New York City put into practice principles new to the planning of American cities. Fundamentally, the effects of the law are two: It safeguards the interests of the city and of adjacent property owners in the location and in the design of all buildings; it organizes the city into a coherent, highly developed system of districts or neighborhoods, in which each district unit is clearly defined, and its character maintained by the provisions of the law.

Quite different is this conception of a city from older notions prevailing in America. Both in law, and in fact, our cities are huge, formless masses of streets and blocks, sprawling over areas of geography, none too well accommodated to conditions of topography. Their maps develop haphazardly, without any rational control, in whatever ways irresponsible private interests dictate—usually in deeper confusion as the complexity of modern life increases, and generating as they grow discomfort, demoralization, and economic loss.

The street system of itself brings no real organization into a city. With its units of blocks, the street system is nothing more than a scheme of measurement in the city plan, except as it forms part of the transportation system. The truth of this assertion becomes clearer if one compares the plan of a city with the plan of a building. If the floor plan of a building were left as an open space, and if its area were then marked off into a series of small squares, the building would be "planned" like most modern cities. A building has an effective plan only when its floor area is divided clearly into separate but related spaces, each carefully ar-

ranged and dimensioned to suit the purposes for which the building is used. So likewise, a city becomes an organized, efficient structure, only when it is arranged by districts, each of which is a carefully defined unit serving a definite purpose. And, since a city cannot be divided into units by walls, its neighborhoods must be set off from one another by law, and by law its character must be prescribed through requiring that all the buildings that are erected within the bounds of each district conform to the standards established for the district. In a word, one may compare this new conception of a city with the older one by saying that older ideas picture the city as a kind of fungus, in which the street and block system are the cells; while the new ideal created by the Zoning Resolution conceives it to be a mechanism of related parts, or units, in the shape of neighborhoods.

The break in ideas is evident in the working out of the zoning scheme. The districts were established by classifying them into types. The types were determined not at all arbitrarily, but only after a long study which, at the time that it was made, impressed people by its breadth, its thoroughness, and its practical and scientific accuracy. As a result of this investigation, the legal neighborhoods which are formed by the Zoning Resolution correspond closely to the physical characteristics of the neighborhoods as they existed—some of them vaguely defined—at the time of passage of the resolution. The physical characteristics of the neighborhoods are chiefly their area of streets and blocks, and types of buildings, and, even more important, their local social and economic organization.

But it should not be thought that the character of these neighborhoods was

fixed solely upon their local aspects; the process of zoning also covered the city as a whole and took account of all its many factors of co-ordination. In the resulting scheme, the block system is but the unit of measurement, and recently it is coming to be thought of as the proper unit of housing in apartments. Thus the century-old block sub-division into lots 25 by 100 feet promises to become obsolete. This relationship of housing to city planning was treated in the two preceding issues of the *Architectural Record* under the title of "Garden Apartments in Cities."

But, important as zoning is, its organization of a city into a mechanism of districts is not the whole of city planning. City planning has come to mean in recent years a multitude of activities, and its field has expanded until it includes most of the aspects of city life. The relationships of these other aspects to zoning deserve a brief notice.

City planning may be said to have both a mechanical and a non-mechanical side. The mechanical side includes the familiar activities of engineering, sanitation, the street system and transportation. On the non-mechanical side there are the human relationships, taking form in countless ways, but principally in the fields of law, political administration, economics and social organization. Together, all this variety of factors tends to create a tangle of interests, which hitherto has foiled attempts to unravel it. The confusion has bred in some quarters an attitude of hopelessness toward the problems of the modern business city. Many observers have pronounced the task of organizing a city to be impossible, and they can see at best but a method of haphazard day-to-day meeting of difficulties as they arise.

The zoning principle definitely repudiates this muddle-through method of city organization. Zoning is only another factor of the mechanical side of city planning; and housing is still another new department to be added to those of engineering, sanitation and transportation. Now when we view this mechanical side of city planning as a whole, it would seem as if a significant truth in regard to

it becomes apparent. That is, the mechanical activities of a city function more efficiently, and reach higher standards than do the non-mechanical activities of political administration and of social and economic relationships. These latter, every one knows, are the dark part of modern business cities. Consequently, in view of the contrast, may not the essential need of a city be to regard it as a structure and as a mechanism of city planning and engineering and of architecture; and then to plan and to construct it soundly on this basis? If that be done, the political and social side of the city, with all its human relationships, might become more wholesome. There might then be less confusion and disagreement and partisanship. It would seem as if many of the troubles of city life were debated on the wrong premises. Energies are wasted in a conflict of isms and ologies, when the real cause may be discomfort, due to faults in the mechanical structure. The civic organization can hardly function properly in a city if the city is not planned to accommodate it, any more than a business organization can be efficient if it operates in a building that has not been planned to suit its needs.

When these broader relationships of zoning in the city plan are thus understood, one will more easily appreciate the technical operation of its principles. It should be said that the law itself is intricate in its workings, because it deals with the intricate conditions of New York real estate. These in turn reflect both the divided topography of the Port of New York and of the surrounding lands, and also the complex, growing, ever changing character of the modern business city. For these reasons, taking a specific example, the particular technical details of the law which deal with heights of buildings are much more involved than the corresponding building regulations of certain European cities like Paris. Paris is a city of a long history of steady, slow growth, which has been carefully planned and controlled for generations. Also, Paris is not a center of commerce like New York, and it is not to any extent in-





LIGGETT-WINCHESTER-LEY CORPORATION BUILD-  
ING, NEW YORK CITY. CARRÈRE & HASTINGS,  
AND R. H. SHREVE, CONSULTING ARCHITECTS.

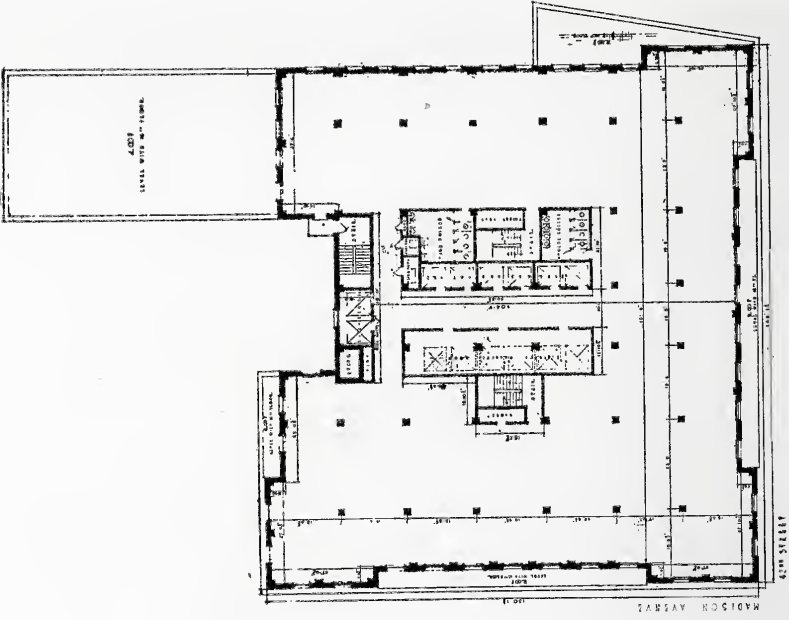

Plan of Sixteenth Floor.

LIGGETT-WINCHESTER-LEY CORPORATION BUILDING, NEW YORK CITY.  
 Carrère & Hastings and R. H. Shreve, Consulting Architects.

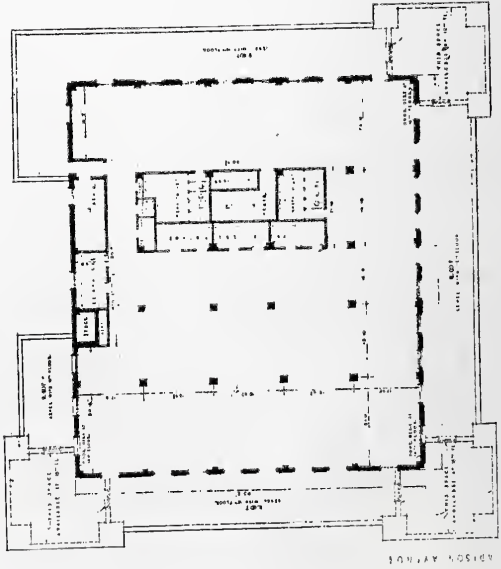

Plan of Eighteenth to Twenty-second Floor.

LIGGETT-WINCHESTER-LEY CORPORATION BUILDING, NEW YORK CITY.  
 Carrère & Hastings and R. H. Shreve, Consulting Architects.



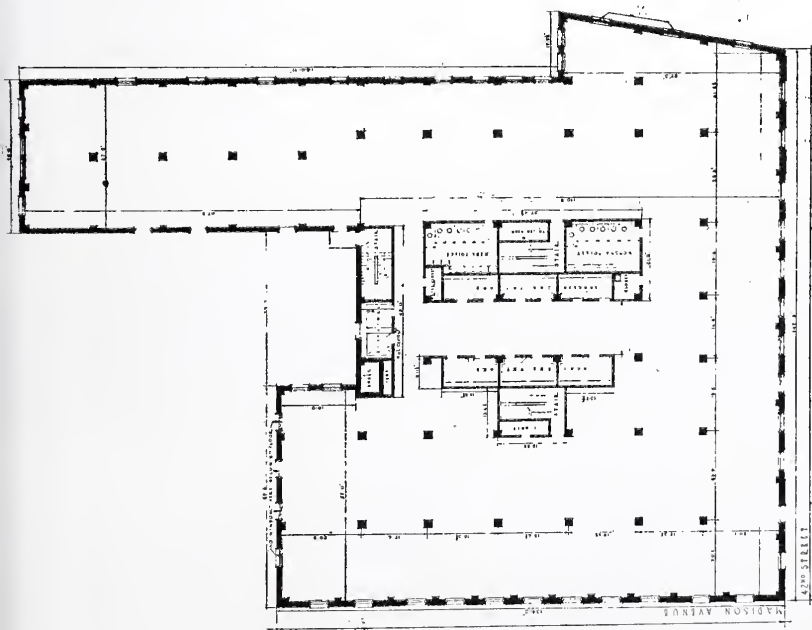

Plan of Third to Twelfth Floor.

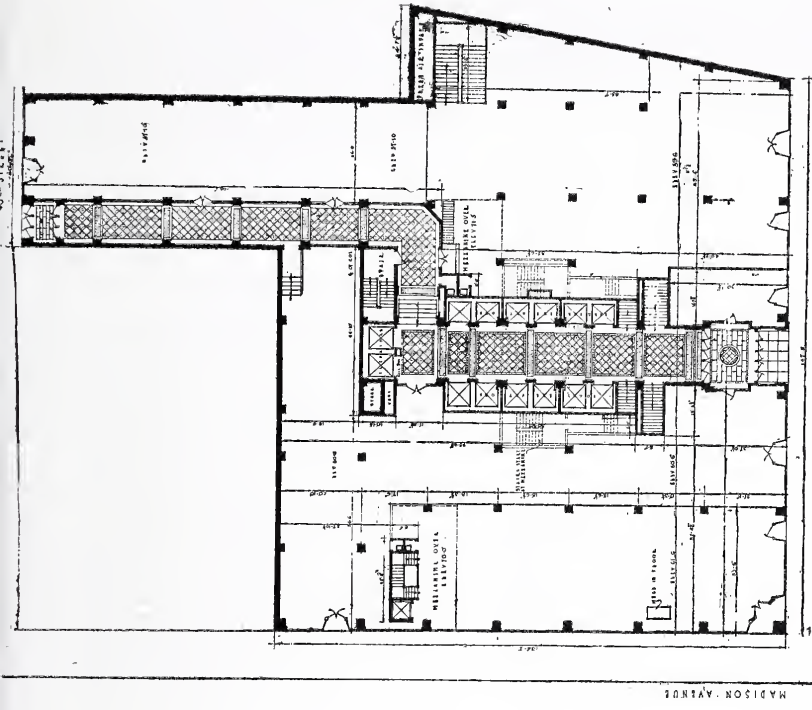

Plan of First Floor.

LIGGETT-WINCHESTER-LEY CORPORATION BUILDING, NEW YORK CITY.  
 Carrère & Hastings and R. H. Shreve, Consulting Architects.

dustrial. The Paris restrictions are rigorous and simple in application; and they enforce aesthetic principles, because they recognize that a beautiful city has value, even commercially.

In establishing zones or districts, the Zoning Resolution divides the city into three classifications, called Use Districts, Height Districts, and Area Districts. The classification into Use Districts defines the types of buildings that may be erected in each district. Use Districts are divided into (1) Residence, (2) Business and (3) Unrestricted Districts. In Residence Districts all buildings that are built after the adoption of the Zoning Resolution shall be residences, although certain types of buildings named in the law that are normally required in a residence area are permitted. These are such buildings as schools, churches, clubs, telephone exchanges, etc. In the Business Districts certain industries are definitely forbidden—principally large scale industries which cause noise, odors, or other disagreeable effects, like stock yards, boiler works, or chemical factories. Industries of small size and of unobjectionable character, particularly those in which a product like clothing is made and sold at retail on the premises, are encouraged under certain restrictions. In Unrestricted Districts any type of building may be erected, though it is understood that, since many of these districts are but partly developed—usually these are situated on the outskirts of the city—they may hereafter be “restricted” when their identity becomes more clearly defined and if it is deemed advisable to preserve this identity.

The scheme of the Height Districts is less simple. In brief, the object in fixing heights is to establish a gradation of heights of buildings adjusted to two conditions. One is the advisability of allowing very high buildings in centers of intensive commercial activity, notably on Manhattan Island, as one extreme; and of establishing a gradation of heights scaling down, at the other extreme, to the outlying residence districts where isolated houses or semi-detached houses are the rule. The other condition is the varying

width of streets, which is recognized in the principle of cutting down the heights of the buildings proportionately on the narrower streets, in order to protect the rights and equities of property owners in sanitation and light and air. These objects are accomplished in a variety of ways. First, there is the division of the city into five types of Height Districts, called the “one,  $1\frac{1}{4}$ ,  $1\frac{1}{2}$ , 2 and  $2\frac{1}{2}$  times” districts. How this rule operates technically may be illustrated by taking the “ $1\frac{1}{2}$  times” districts as an example. It means that if the street on which a building is to be built is 100 feet wide, taking the width between building lines, the building height will be  $1\frac{1}{2}$  times 100 feet or 150 feet. This refers to the height of the building at the building line. Above that height the building may go higher, provided the wall on the building is set back in the same proportion, that is, set back  $1\frac{1}{2}$  feet for every one foot of height that the wall is carried up. Several setbacks may be built, all conforming to the angle formed by drawing a line from the center of the street through a point in the top of the wall of the first setback on the building line. The principle is more easily understood by referring to the illustrations of the buildings in these pages. On streets less than 50 feet wide, height regulations are those of 50 feet wide streets, and on streets more than 100 feet wide, or on streets fronting parks, the height regulations are those of streets 100 feet wide. This latter exception embodies the principle that on a wide street a tall building robs the neighbors at the rear of light and air as much as it would if it were located on a narrow street.

Besides this general proportioning of heights the law introduces further refinements. It requires setbacks on “exterior” or street lines, but not on “interior” or lot lines. Projections above walls—termed “dormers” or bulkheads—are allowed under certain limitations. As an example, the turrets at the corners of the first setback on the Liggett Building, illustrated herewith, are technically “dormers” under the law. A similar slight excess is allowed for cornices and para-





FISK BUILDING, NEW YORK  
CITY. CARRÈRE & HASTINGS AND  
R. H. SHREVE, ARCHITECTS.





WEST 57TH STREET

TUGHER AVENUE

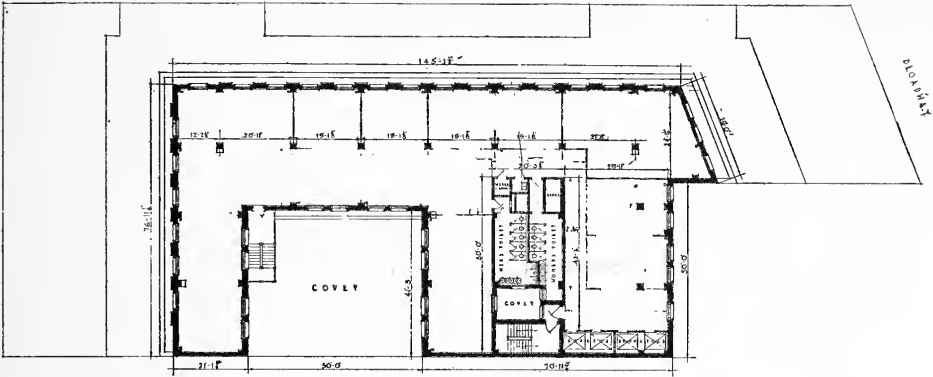

→ 25TH FLOOR PLAN →

FISK BUILDING, NEW YORK CITY.  
Carrère & Hastings and R. H. Shreve, Architects.

pets. Another variation permits excess heights where a building is constructed amid a group of old buildings that were built before the Zoning Resolution was adopted, and which were carried to greater height than is now permitted.

Still a fifth variation of the height regulations deserves attention. Under limitations governing position on the plan in relation to building lines, street corners, etc., a tower may rise to any height desired, provided it does not cover more than 25 per cent. of the lot area. This provision for towers is one of the finest

features of the zoning resolution, for it encourages the building of great towers like those of the Woolworth and Metropolitan Life, which have added so much to the beauty of the city.

The division into Area Districts follows the same principles as those employed in the height districting, especially in preserving standards for light and for ventilation. The Area classification also recognizes the gradation between the desirable height extremes of Commercial and Residence Districts. It increases the sizes of interior courts and yards as the heights

WEST 57TH STREET

SIXTH AVENUE

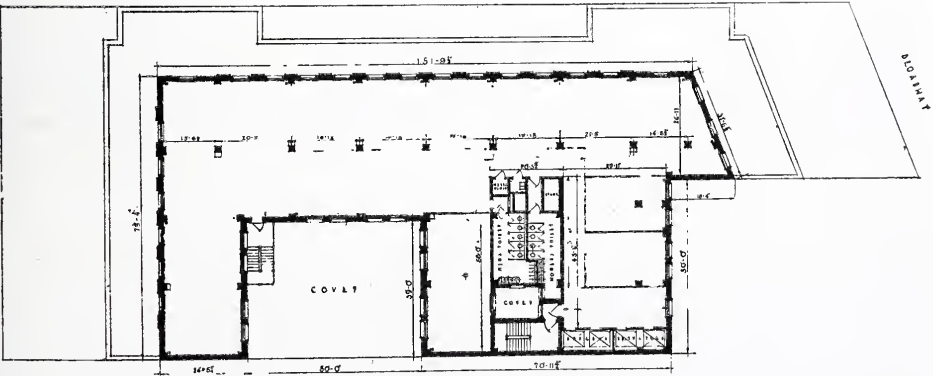

→ 20TH TO 24TH FLOOR PLANS INCL →

FISK BUILDING, NEW YORK CITY.  
Carrère & Hastings and R. H. Shreve, Architects.

of buildings increases, corresponding to the Height District classification; and it secures open spaces in Residence Districts by means of an ingenious system. One noteworthy provision is that the area districting scheme operates to encourage the owners of buildings in Residence Districts to set apart additional areas for recreation space besides those required for courts.

Under the scheme of Area Districts five types of districts are established, known as A, B, C, D, E. In the "A" and "B" districts, commercial structures predominate; in the "C" districts tenements are the rule, and in them the area regulations are much like those of the Tenement House Act of 1901 for buildings less than six stories high. "D" district regulations are designed for row housing of dwellings for one and two families. "E" districts are composed of detached and semi-detached private dwellings. In the "E" districts, only 50 per cent. of the area of the lot may be built upon interior lots, and 70 per cent. on corner lots. The "D" districts also have a similar percentage limitation on the area of the lot to be occupied by the building.

The foregoing summarizes the main points of the law, chiefly those establishing the Use, Height and Area classifications. I have carried it only far enough to show how thoroughly the law prescribes the location and design of buildings. For further technical details, the reader is referred to a pamphlet, "Building Zones," published by the Lawyers' Mortgage Company of New York City, which gives a full account of the law and its technical application in architecture, together with many diagrams illustrating the working out of the principles in building design. This admirable pamphlet is the work of Mr. George Burdett Ford, consultant to the commission charged with zoning, assisted by Mr. Herbert S. Swan, well-known for his studies in light and air restrictions on buildings, and by Mr. F. P. Schiavoni.

When the essentials of the law are understood one realizes, I think, how truly they break with old ideas by thus establishing the character of the city as

a mechanism of districts or neighborhoods. In fact, one not familiar with the history of the adoption of the law might ask, how was such a completely new system of city planning ever established in face of the older practice, which allowed an individual to build where, what and how he wished?

The full answer to this question cannot be given here; but I may say that one reason was the extraordinary effort to make the provisions of the law just, and to define the districts with the greatest precision so as to cause the least possible damage to existing property values. Even the excellence of the law, however, could hardly have ensured its adoption had not the growing chaos in New York City real estate forced civic action to relieve it. Property owners were taking alarm. Huge real estate values were being created or destroyed within the space of a few years' time in certain areas, until finally the old system actually broke down in some blocks. According to Mr. Lawson Purdy, an authority on New York real estate, the construction of the Equitable Building on lower Broadway injured the equity in surrounding property, by monopolizing the light and air, to the extent of over a million dollars, and the city was forced to reduce adjacent assessments by at least that amount. Further uptown a single block, in size 200 feet by 800 feet, was assessed in 1911 for \$17,000,000 and in 1916 for \$7,000,000; the erection of industrial buildings in the district was the chief cause of the loss. Cases like these persuaded people to accept the zoning system as the only way to protect property values. The system has proved a success, and today no one would care to return to old methods. In fact, only four cases attacking the validity of the law have so far been tried in the courts, and these were decided on grounds that did not affect the constitutionality of the law itself; thus the constitutionality of the Zoning Resolution has never yet been passed upon.

As concerns the legal aspect of zoning regulations, the weight of authority seems to be that they can be made to conform to our American legal system. The



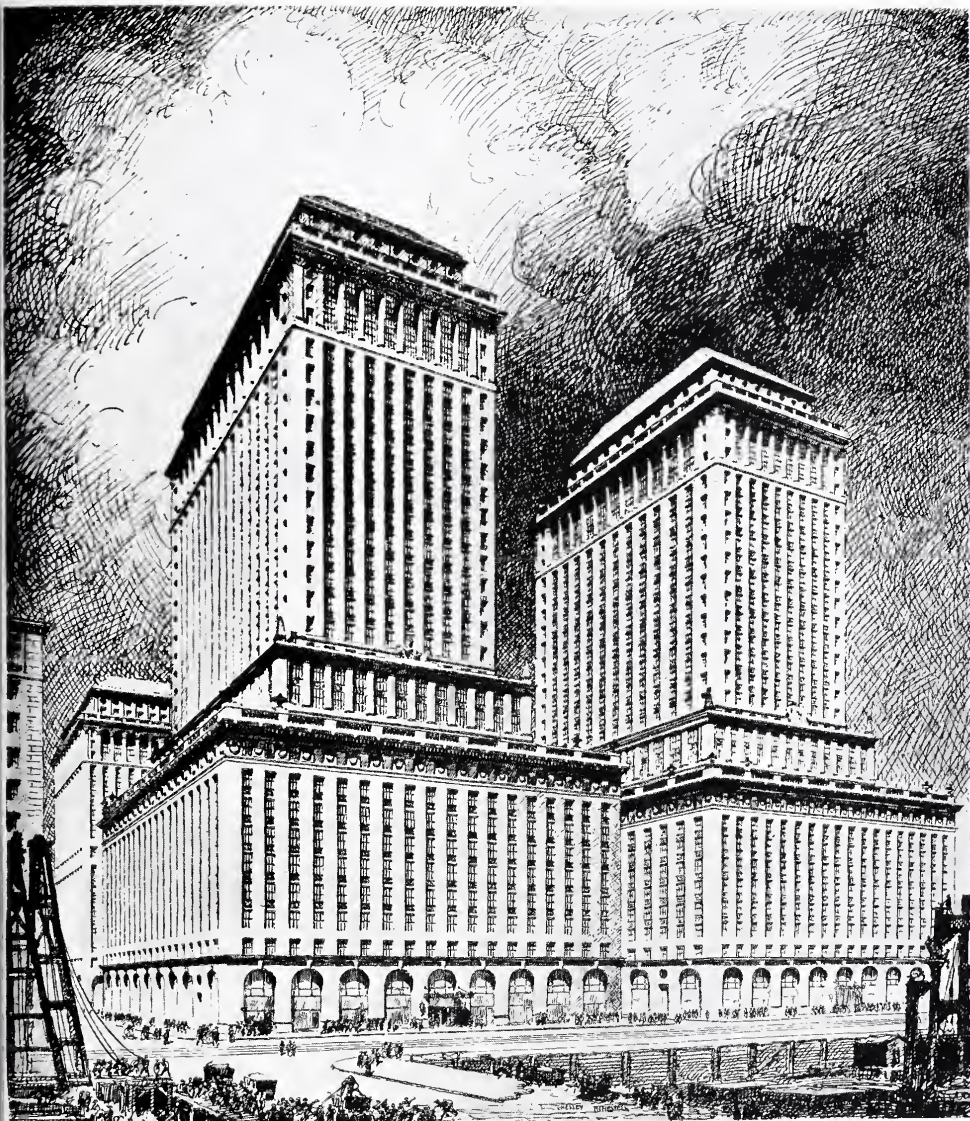

PARK-MADISON BUILDING, NEW YORK CITY. WARREN & WETMORE, ARCHITECTS.

EAST FORTY SEVENTH STREET

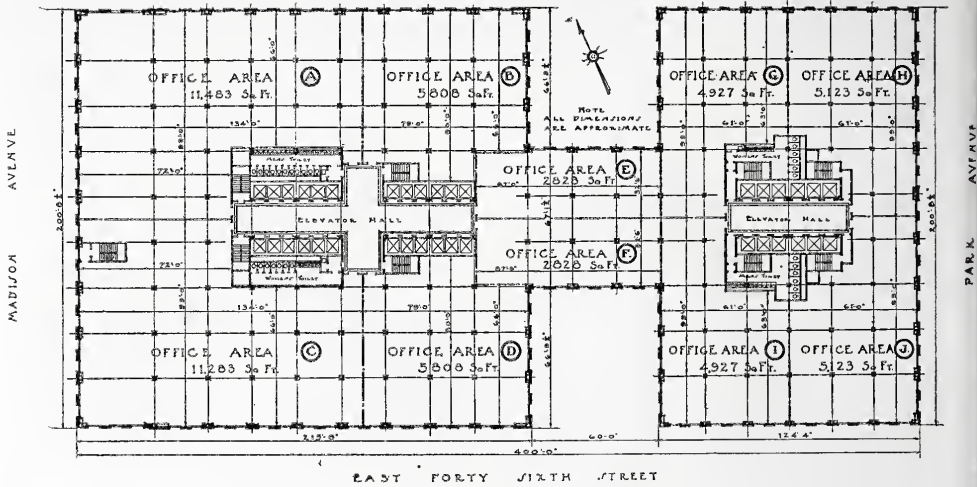

TYPICAL FLOOR PLAN  
THIRD TO NINTH FLOORS INCL  
Scale: 1/8" = 1'-0"

PARK-MADISON BUILDING, NEW YORK CITY.  
Warren & Wetmore, Architects.

courts in recent years have upheld laws of various states, which contain some of the principles applied in zoning. They have done this on the basis of the police power, "which extends to public health,

morals and safety." Sanitation is legally a function of the police power, and thus a property holder may be forbidden to build his building so high above adjoining buildings as to rob his neighbor of

EAST FORTY SEVENTH STREET

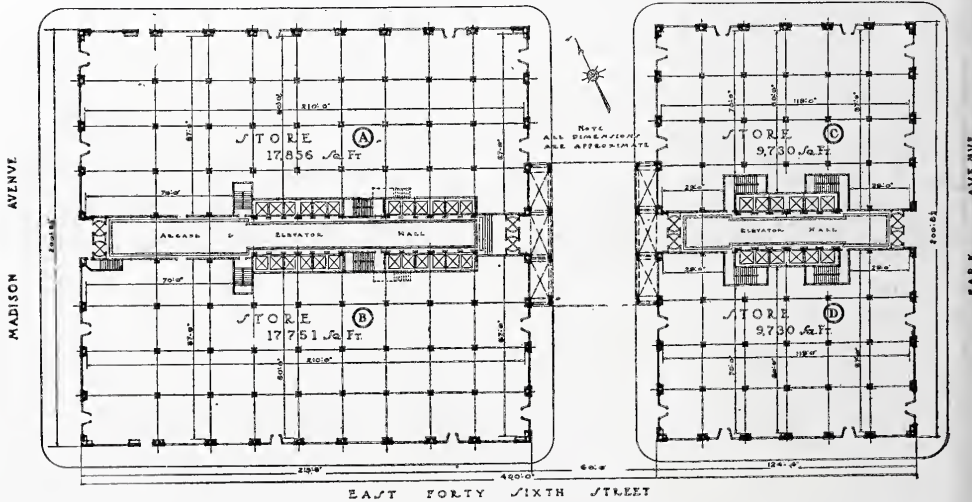

FIRST FLOOR PLAN  
Scale: 1/8" = 1'-0"

PARK-MADISON BUILDING, NEW YORK CITY.  
Warren & Wetmore, Architects.



light and air. A commission is charged with the operation of the law.

With this account of the chief characteristics of the Zoning Resolution ended, we may proceed to some illustrations of its specific operation in the design of buildings. The buildings shown herewith are all huge commercial structures, and form, therefore, only one class of all the buildings which are affected by the law. This is, however, the class that is most

sulting architects. Their design developed the possibilities of the law in a striking way, and the favorable situation of each on corner lots permitted the architects to take full advantage of their opportunity. As a result, New York City gains two bold, splendid monuments of architecture.

The Liggett Building, as it is coming to be called, is in process of construction on the corner of Madison Avenue and Forty-second Street. The key to the suc-

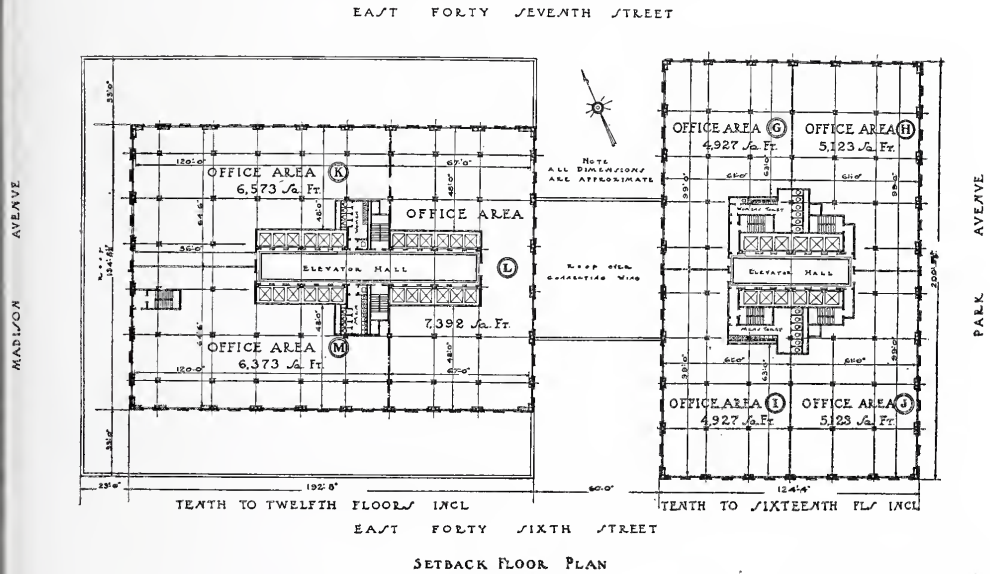

PARK-MADISON BUILDING, NEW YORK CITY.  
Warren & Wetmore, Architects.

drastically controlled, and the one which illustrates its operation most clearly. Of the other classes, hotels are similar, factories are not often built up to unusual heights, and, in Residence Districts, the provisions of the law do not differ much from the provisions of the Tenement House Act, except to reinforce it in some particulars. Consequently, tall office buildings are fairly typical of the effects of the zoning principles.

Of the buildings illustrated herewith, none typify better the workings of the law than the Liggett-Winchester-Ley Corporation Building, and the Fisk Building, for both of which Carrère & Hastings and R. H. Shreve acted as con-

cess of this building lies—as in most triumphs of architecture—in its plan. It will be noted that most of these structures illustrated are planned solid, without a center light court. Under the zoning restrictions, such a court would be very large; and, if it made the plan of the building a hollow square, the great area needed for the service features of corridors, lobbies, elevators, stairs, toilets, etc., which bring in no rent, would be subtracted from the desirable space along the outside wall. But, by building the plan solid, these service features are placed in the center, where the space is not well lighted and is hence not rentable for offices. This arrangement makes not

only an efficient plan, but, in the upper stories, it has the great merit of facilitating the beautiful setbacks in terraces and towers. In the Liggett Building, for example, the fine central tower—which is the making of the design of the exterior—could never have been constructed over a center court.

The illustration showing the perspective of this structure indicates that it should be one of the most effective buildings in New York. Such distinction in mass, outline and detail, if carried into all architecture, would make the business districts of American cities beautiful—not only in respect to individual buildings, but considered from the aspect of each street as a whole. They would furnish an extraordinary picture where the building masses would harmonize by virtue of the cornice line of the first setback coming on the same level, forming thus a vast terrace, above which would rise a wonderful array of minor terraces, pavilions, loggias, roofs, dormers, turrets, towers, all pyramiding into the sky. New York might vie with ancient Rome of the seven hills, but in a different way, in a character entirely its own. Such is the possible effect of the zoning principle, and how different it is from the present collection of crude cubical masses that poke their harsh, gaunt outlines into the sky, without any harmony of one building to another, blunt, angular objects that no skill in design or in details can redeem or else conceal. I believe that the reader will admit that this picture of the ugliness of American cities is not exaggerated. It is true, here and there the imagination of the architect and the appreciation of an owner have created a building that shows artistry in its mass and outline; but such exceptions are rare, and they occur mostly when a building resembles the form of a tower. The beauty of these towers suffers from the proximity of bulkier structures. Even the tower of the Woolworth Building is somewhat marred by the two low, boxlike wings beside it. Had the Woolworth Building been erected after the passage of the Zoning Resolution, Mr. Cass Gilbert

would not have let pass the opportunity thus offered of modelling the lower wings in setbacks and terraces, so that their form and outlines would have harmonized better with the design of the tower. On the whole, it is fair to say that most of the tall buildings of New York antedating the Zoning Resolution are failures architecturally, in spite of the ingenuity which their architects have lavished on them, trying vainly to overcome their blocky mass. Such beautiful effects as one sees are due either to isolated towers or to occasional picturesque effects of groupings or perspectives which are purely accidental. Of such is the famous spectacle of the buildings in the financial district of lower Manhattan, where the ugly blocks of the bulky buildings cannot be distinguished from the silhouette of the mass, with outline of the whole group accented here and there by the tall towers of the Woolworth, the Singer and the Bankers' Trust buildings. And if New York is afflicted with many ugly tall buildings, what shall be said of other cities, whose picture shows two or three or a half dozen colossal, crude, block-line structures poking up at intervals above low buildings into the sky, without shape or proportion, unrelated to each other—about as beautiful and as inspiring as a collection of packing cases on a sidewalk. Quantity is not quality, and vast size of itself is not a recipe for beautiful architecture.

On the other hand, one should not make the mistake of concluding that the Zoning Resolution of itself creates beautiful buildings. It merely offers the architect an opportunity to prove his ability. As stated above, the law is based on economic and sanitary factors, and does not directly take account of aesthetic values. If the desire for fine architecture appears to be growing in New York City, that is due to the spirit of the owners of these tall buildings, and to the architects, who are slowly persuading the public of the truth that fine architecture has definite value in a commercial building. Therefore, the effect of the Zoning Resolution is to offer the architect a geometrical shell which is based almost solely on sanitary



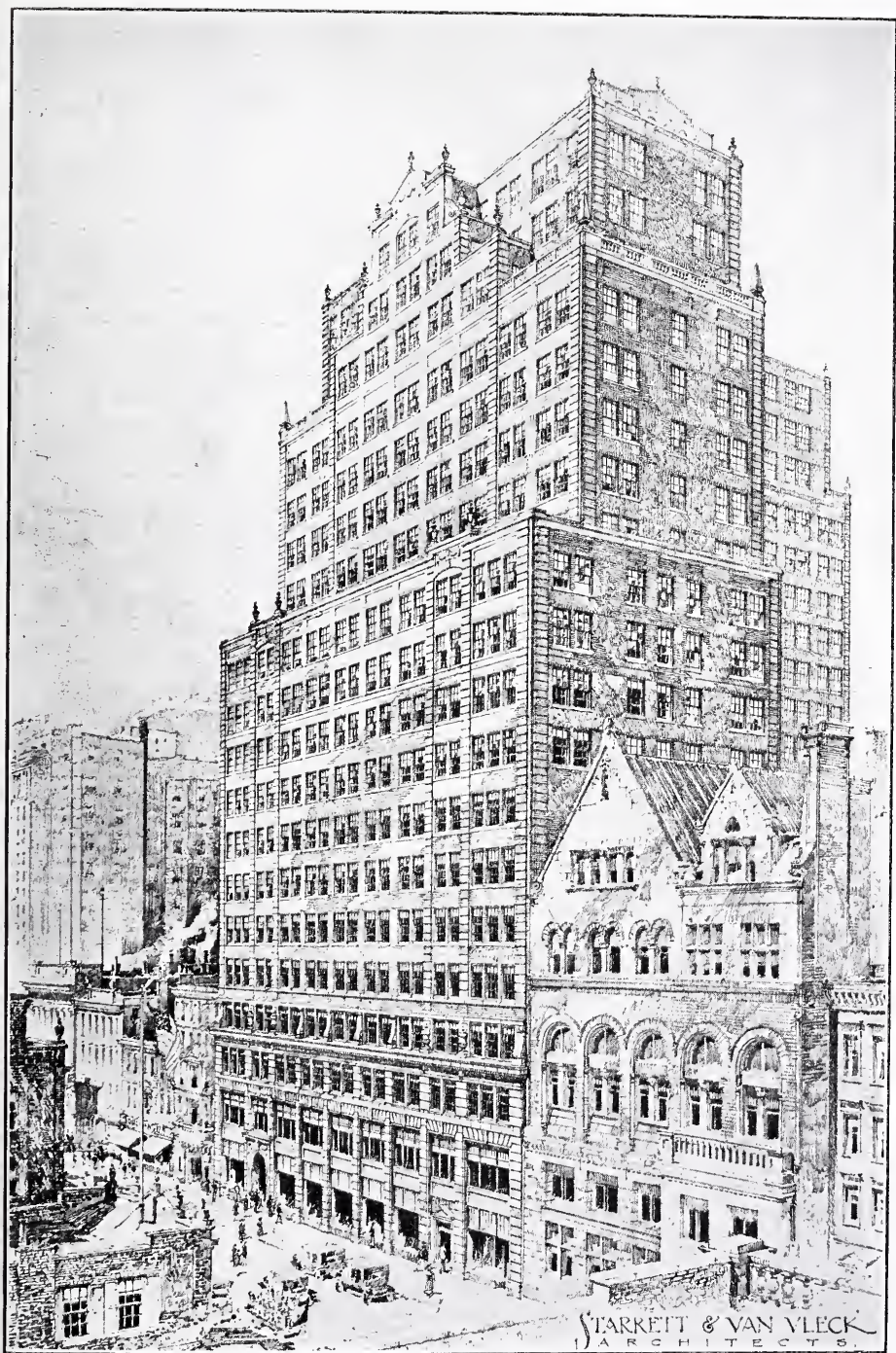

NATIONAL ASSOCIATION BUILDING, NEW YORK CITY. STARRETT & VAN VLECK, ARCHITECTS.

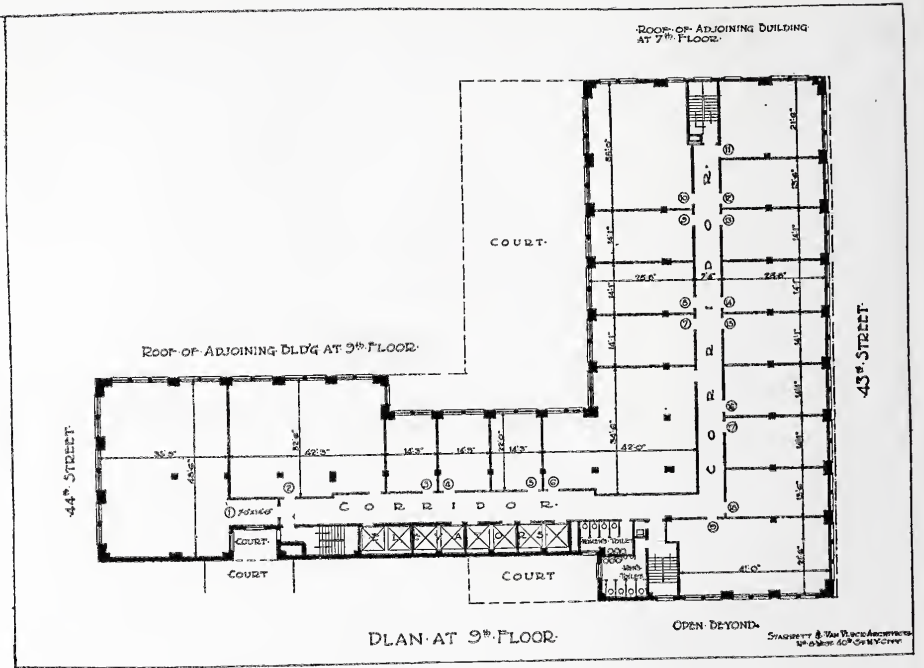

NATIONAL ASSOCIATION BUILDING, NEW YORK CITY.  
Starrett & Van Vleck, Architects.

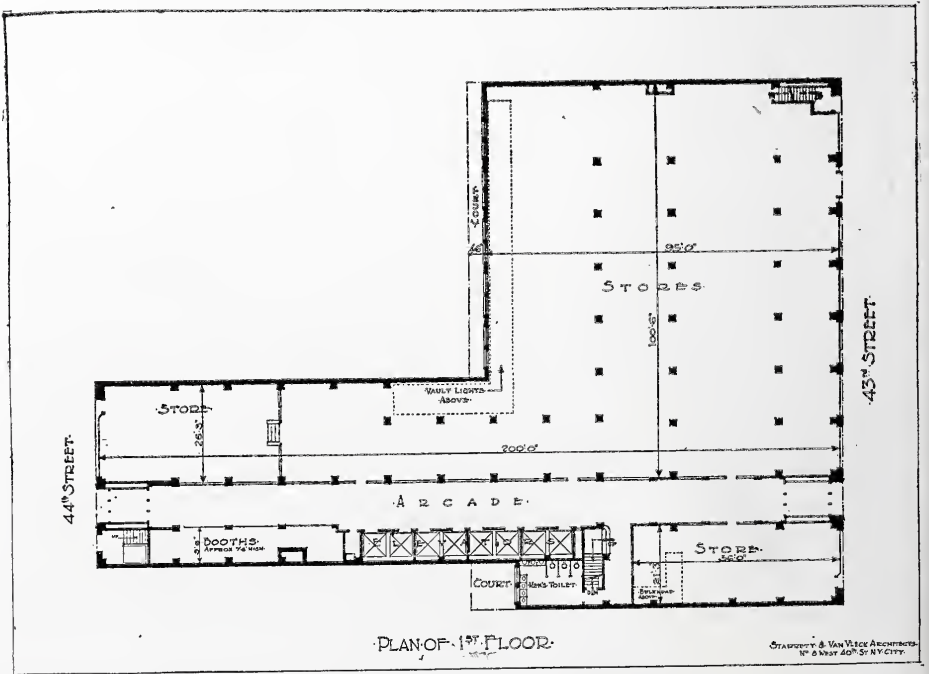

NATIONAL ASSOCIATION BUILDING, NEW YORK CITY.  
Starrett & Van Vleck, Architects.





and financial considerations. If the architect proceeds to fill this shell with a building, he will find that the result has no form or proportion or symmetry of outline. It is his duty to model within the limits of the legal shell a beautiful building. In the process he may even find it necessary to persuade the owner to sacrifice a bit of space here and there in order to achieve his design.

Such was the method employed in the Liggett Building. The fine symmetry of its upper stories is not prescribed by the law, which would enforce only two setbacks, those in the streets. The setbacks have been carried around the other two sides, where a small amount of space was sacrificed beyond the requirement of the law in order to gain the effect. The owners thus viewed the project broadly, carrying the same fine appreciation into details, with concessions here and there to design, yet at the same time mindful of the necessary limitations of cost of a business structure. For instance, they objected to the use of metal spandrels between the windows, which, painted black, made possible the fine vertical lines of the front, but approved the making of these spandrels in black terra cotta. The owners, on their own initiative, installed marble wainscots in the corridors of all floors. I cite these details to show the broad point of view that governs the design of these great buildings, and how even present costs do not prevent people from obtaining fine architecture.

Some further features of the design of this Liggett Building are of interest. In the elevations, factors of design and cost are finely adjusted. Brick was used effectively instead of more expensive materials, and the blending of color promises to be one of the best features of the upper stories. In the two lowest floors, the big motive of glass and metal is a bold device in design, forming a fine, strong base to the whole building, and yielding the maximum space for the show windows of the stores. This is a far better solution than the usual thin, long lines of stone, wide apart, that cover

the steel points of support, a very weak looking effect indeed.

In designing the Fisk Building, the architects again showed fine understanding of the features of the law. Where, in the Liggett Building, they demonstrated to the owner how fine a design might be obtained, in the Fisk Building they upheld the same principle before the Zoning Commission. It happens that the Fisk Building, located at 1767 Broadway, lies across the boundaries of a "1½ times" and a "2½ times" Height District. A literal following of the restrictions would have dropped the first setback on Eighth Avenue much lower for a distance of 100 feet, and would have carried this setback along Fifty-seventh Street. This would have cut off a corner of the first setback on Fifty-seventh Street and thus made a fine, symmetrical design impossible. When the architects perceived how the law operated so unfortunately in this instance, they went before the commission and asked, and obtained, an exception which allowed the first setback on Fifty-seventh Street to be raised to the height of the one on Eighth Avenue. Their appeal was based solely on the wish to provide a beautiful building; and following this object, the architects agreed to set back the rear of the building more than the law required, so that the space thus sacrificed equals the space gained by raising the setback. Thus their clients gained no financial benefit from the change. This decision reflects admirably upon the board and the architects, for, although the board does not solicit exceptions to its regulations on artistic grounds—that depends on the initiative of the architect—by its action it showed itself willing to admit the factor of architectural beauty into its policy. It is to be hoped that this principle will be extended in zoning.

A third splendid structure is the Cunard Steamship Company's building in lower Broadway, in the financial district of Manhattan, now under construction, of which Mr. Benjamin Wistar Morris is the architect. Its plan is exceptional by reason of the huge open domed lobby on the ground floor to be used by the Cunard





A. D. PICKERING  
103 PARK AVE. N.Y.C.  
STARRETT & VAN VLECK  
8 W 40th STREET N.Y.C.  
-ARCHITECTS-

C. J. JEPPESEN  
56 W 45th STREET N.Y.C.  
CONSULTING ENGINEER

MADISON AVENUE OFFICES, NEW YORK CITY. STARRETT & VAN VLECK AND A. D. PICKERING, ARCHITECTS.

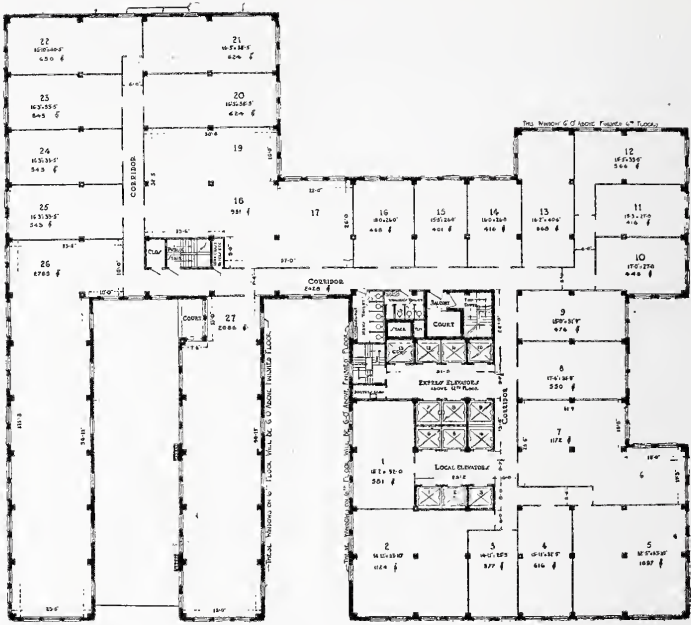

TOTAL RENTABLE AREA - 5702 sq. FEET FLOOR - BASE OF CORRIDOR.  
 NOTE: ALL DIMENSIONS & AREA APPROXIMATE

MADISON AVENUE

44' 7" / 10' 11"

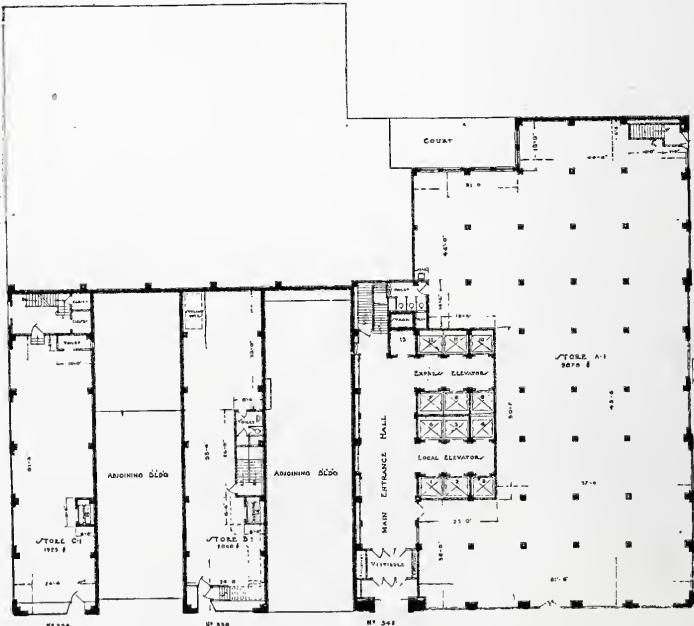

TOTAL RENTABLE AREA - 1800 sq. FEET  
 NOTE: ALL DIMENSIONS & AREA APPROXIMATE

MADISON AVE

44' 7" / 10' 11"

MADISON AVENUE OFFICES, NEW YORK CITY.  
 Starrett & Van Vleck and A. D. Pickering, Architects.



organization. The fine massing of its upper stories should add to the appearance of the district.

Warren & Wetmore are the architects of the Park-Madison Building, which occupies the whole block between Madison and Park avenues and Forty-sixth and Forty-seventh streets, and is now under construction. Here, also, like its neighbor, the Liggett Building, the elevators and similar services occupy the centers

avenues, and was recently completed; while the second is being erected on Madison Avenue, between Forty-third and Forty-fourth streets. The first has not the advantage of a situation on a corner like the other buildings, but the architect has effected a striking pyramid of terraces. This building illustrates the terracing principle of setbacks to a higher degree than most buildings. In the building of the Madison Avenue Offices

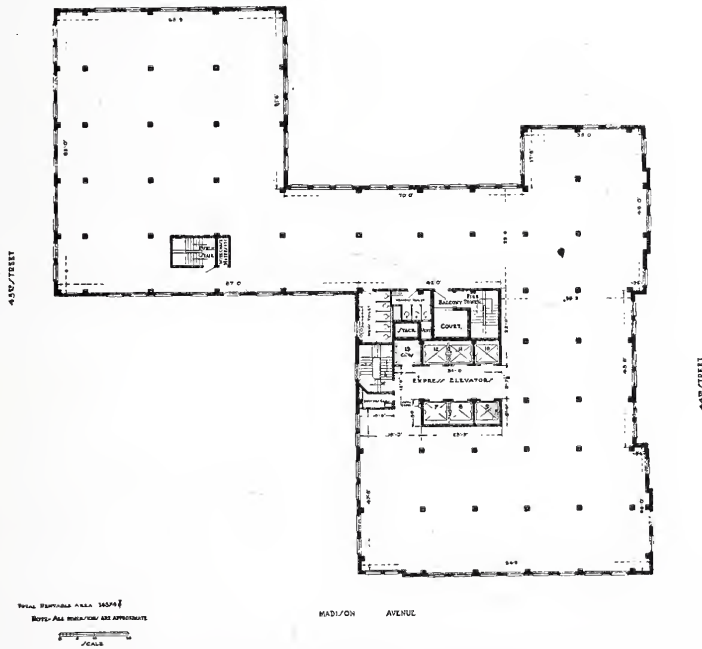

MADISON AVENUE OFFICES, NEW YORK CITY.  
 Starrett & Van Vleck and A. D. Pickering, Architects.

of the two parts of the buildings, which space is too dark to be rentable for offices. Monumental, indeed, are its vast proportions, with its twin-like upper parts rising above the lower mass, their tops well modeled with setbacks. This design conforms to the style of most of the buildings in this district around the Grand Central Station, which was also designed by Warren & Wetmore.

The National Association Building and the Madison Avenue Offices are both designed by Starrett & Van Vleck. The first runs from Forty-third to Forty-fourth Street, between Fifth and Sixth

the owners could not gain possession of the two lots in the area built upon, and as a result the building could not be designed as a whole. This is to be regretted, for Starrett & Van Vleck have produced some fine business buildings. Their older design, No. 8 West Fortieth Street, is one of the most beautiful business buildings in New York, in its towerlike aspect, exquisite outlines, fineness of scale and beautifully blended color of light tan brick and limestone details that fuse like a pattern of tapestry in the upper portions. I have always admired the color of this edifice, which is of a quality

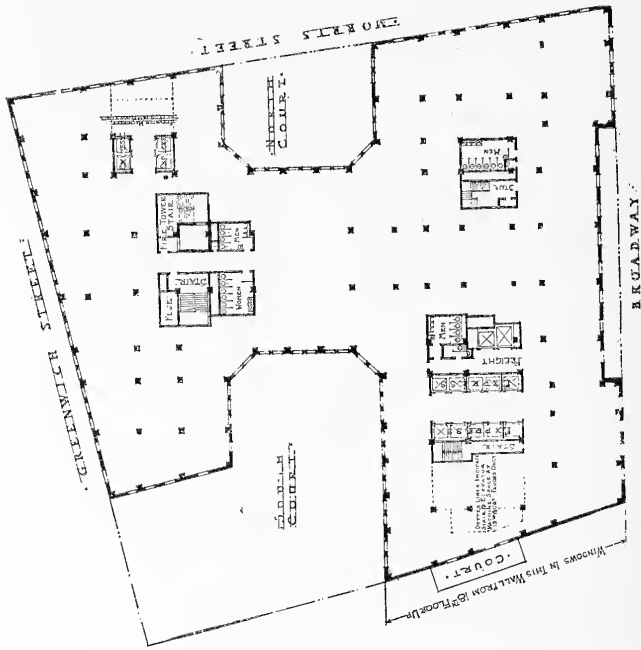

Plan of Fifteenth to Eighteenth Floor.

CUNARD BUILDING, NEW YORK CITY.  
Benjamin Wistar Morris, Architect.

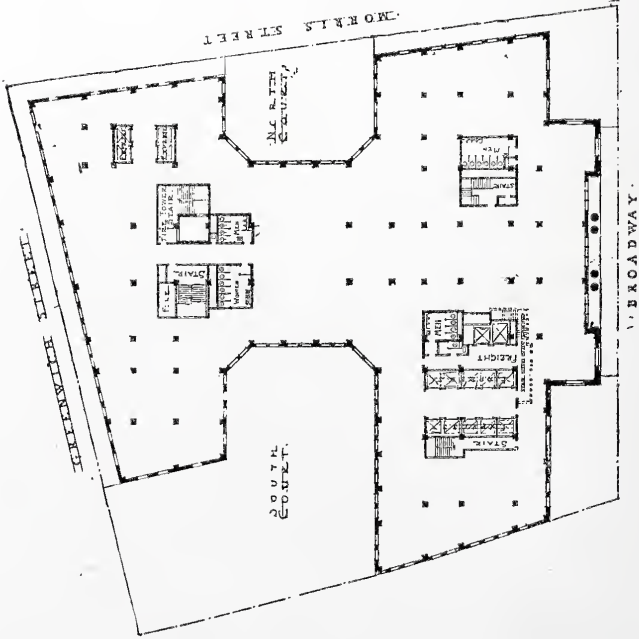

Plan of Nineteenth to Twenty-first Floor.

CUNARD BUILDING, NEW YORK CITY.  
Benjamin Wistar Morris, Architect.





Plan of Fifth Floor.

CUNARD BUILDING, NEW YORK CITY.  
 Benjamin Wistar Morris, Architect.

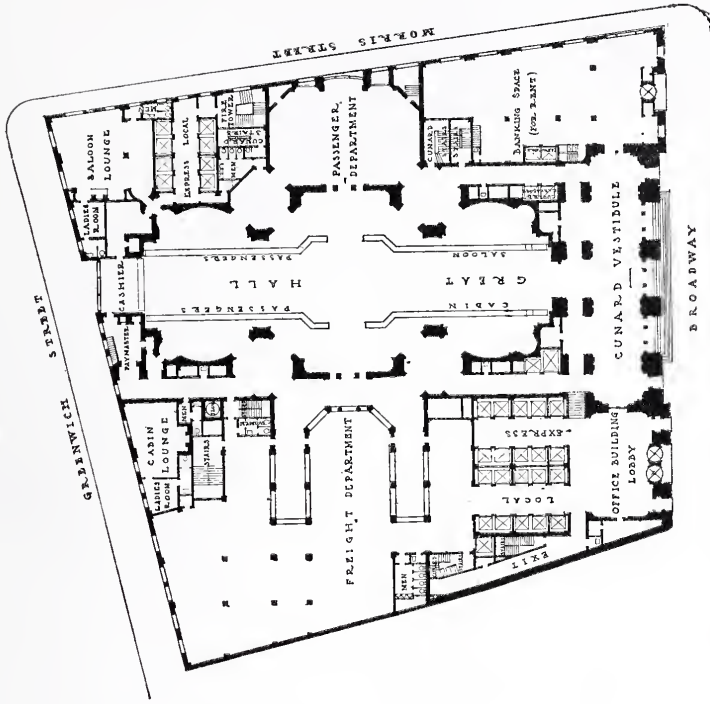

Plan of First Floor.

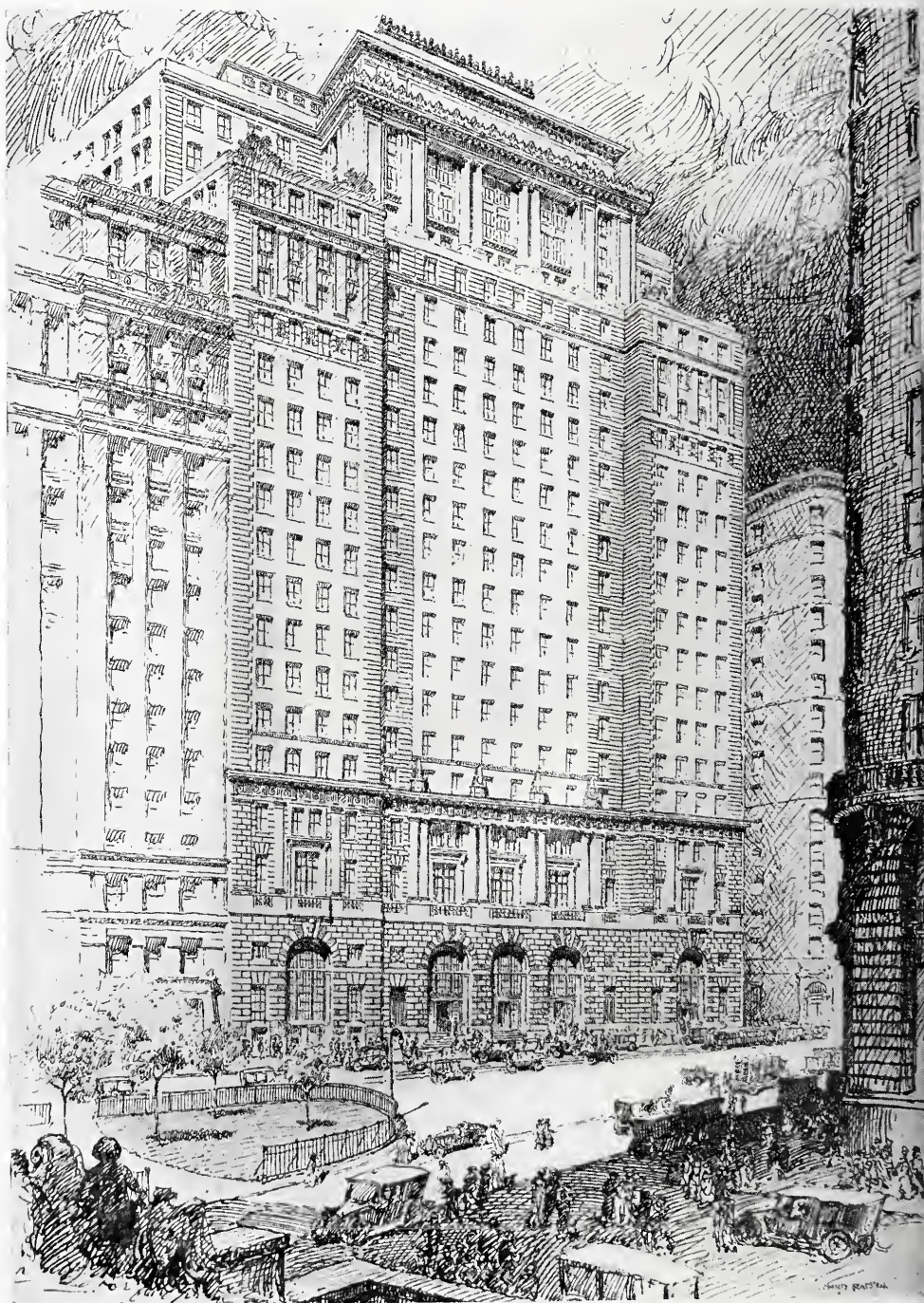

CUNARD BUILDING, NEW YORK CITY.  
BENJAMIN WISTAR MORRIS, ARCHITECT.



that is but rarely attained in tall buildings. Its surface gleams and shines in the sunlight and catches the light so that the color seems always to be changing. Nothing could yield greater charm in a tall building, and it is seen at its best in the Giralda Tower in Seville, Spain. The Giralda, too, has a very light brick, but it is warmer, slightly more roseate in tone in some lights and golden in others. The equally famous Mangia Tower of Siena has this same effect of evanescent color. But so far most of the architects of American skyscrapers have not been able to picture their towers with the eyes of a colorist. Their practice is to accent form and outline until, three hundred feet in air, every detail of their buildings appears as hard, and often as cold, as steel. It might be that the character of some of those old Gothic towers might be studied to advantage, whose tops grow finer in scale toward the tip, in such a way as to cause an illusion of distance, of atmosphere, of mystery. In Renaissance and modern towers the opposite practice is followed, of coarsening the scale in the upper heights. It may be claimed that this latter practice is good architecture; but it can hardly be doubted that the other, the Gothic one, is more surely art.

All in all, New York may look forward to the day when these giant structures shall be completed, when they shoulder their tops of terraced and pyloned masses high above the skyline of the city, into the brilliant light of the sky in America.

At times, when the wind is from the north and the atmosphere is crystal, these vast shapes will jut up gaunt and stark, every line and detail revealed, as if cut from steel, naked in the cold blinding glare. But on other days, when the wind comes off the sea, from the east or south, tingeing the light with a faint mellowness or mist, then the towers will stand in a thinnest dazzling veil of atmosphere, their soaring outlines melting ever so slightly into the blue sky, their vast flanks streaming with sunshine. In this softer, slightly golden illumination they may have something of the harmony and mystery and illusion that brings the final quality of art into architecture.

These new skyscrapers will be the visible symbols of the Zoning Resolution. But one should not forget that they are but the crowning dramatic feature of the deep-lying new purpose of the modern business city—of its new structural organization. The Zoning Resolution is the basic step in city planning; the new city planning that aims to bring order, coherence and coordination into city life. The older conception of a city as a formless, unrelated mass of blocks, growing as it will, tied together by the system of streets, developing haphazardly—this no longer serves the purpose. In New York this idea of a fungus has now given way to an organization of well defined units of districts and neighborhoods, carefully co-ordinated to the plan of the whole city. Such is its theory, and New York came to accept it as a matter of self-preservation.

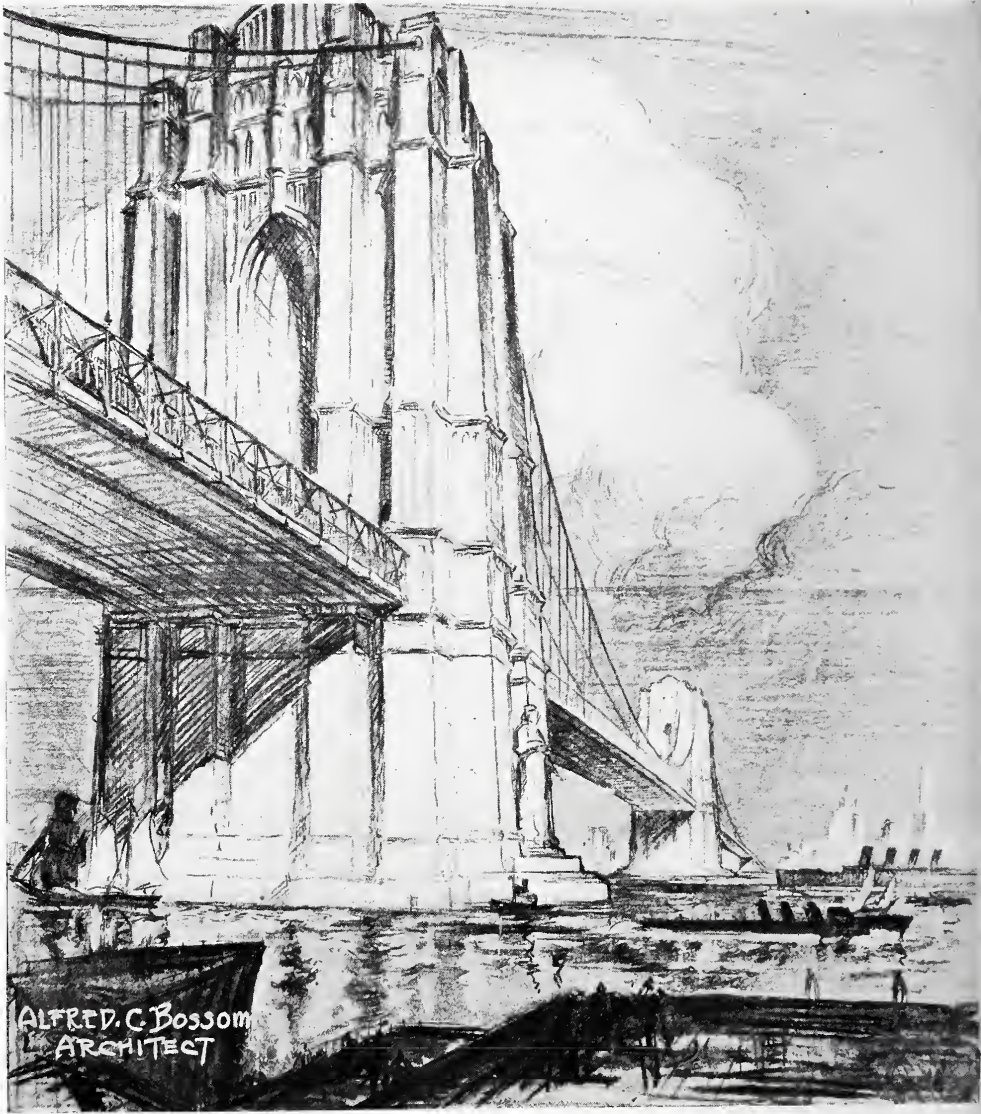

PROPOSED VICTORY BRIDGE OVER THE HUDSON. ALFRED C. BOSSOM, ARCHITECT.



*III The III*  
**PROPOSED VICTORY BRIDGE  
OVER THE HUDSON BETWEEN  
NEW YORK CITY & WEEHAWKEN**

ALFRED C. BOSSOM, ARCHITECT



*By Robert Imlay*

**W**ITH her immense rivers, America is the builder of mighty bridges. The best known of these is the group spanning the East River and connecting Manhattan Island with the Boroughs of Brooklyn and of Queens in Long Island. It is proposed to supplement these East River bridges on the other side of Manhattan with a gigantic new one that shall link New York City with the New Jersey communities on the other side of the Hudson River. The sponsors of the project intend it as a memorial of the late war, to be called the Victory Bridge.

As the illustrations show, this Victory Bridge will be far larger than its predecessors over the East River. It will be larger, because the Hudson River is wider—its span will be one-half mile long; in width and capacity it will be much bigger, since the railroad tracks will cross it on the lowest deck in addition to the traffic of rapid transit, motors and foot passengers; and in the monumental design of its huge towers it will be one of the great works of architecture of the nation. A more daring project could hardly be conceived, yet it is planned to be self-supporting financially. It may be well to point out here that, although in this form the scheme is new, the idea of it is old. The first definite proposal to build a Hudson River bridge came just before the war, when a joint commission of the states of New York and New Jersey was appointed to determine the relative merits of a bridge and a tunnel. A tunnel was chosen as

being more effective at that time, but since the war the traffic difficulties of New York have so increased that the day seems to be drawing near when a bridge will become feasible.

But whatever be the future of this proposed Bridge of Victory, it is of vital interest as a design, and for us its significance lies chiefly in the possible effect on the city plan of New York.

With the traffic tunnel—of which the construction has been authorized—it will be the second great link between Manhattan and New Jersey. Doubtless more tunnels will be driven under the river in the future, for the experts concerned in the construction of the tunnel feel that it will be the first of a group. Thus, by virtue of these surface and sub-surface links, the division created by the Hudson River will be overcome and, in the matter of city plan, the New Jersey communities, of Jersey City, Hoboken, Weehawken, may become an integral part of New York. In fact, in recent years, this conception of planning New York to include the New Jersey side of the river has been growing. It first developed with regard to the Port of New York which—authorities who are not influenced by local allegiance agree—should be conceived to include the New Jersey as well as the New York waters surrounding New York Bay. This viewpoint includes the transportation system of the whole Metropolitan district, particularly the terminal systems of the railroads that radiate into New York City, in New York and New Jersey. The railroads



PROPOSED VICTORY BRIDGE OVER THE HUDSON.  
Alfred C. Bossom, Architect.

serve both the Port of New York and New York City, and the traffic congestion, which has grown up in loading and unloading of freight, its transfer and exchange, threatens, unless it be promptly and radically solved, to injure permanently the Port and the city. Heavy lightering expenses and expenses of motor transport, resulting from the need of these services to supplement the railroads, have laid a heavy burden of charges on commerce.

The pressure of events, therefore, more than anything else, has forced New York City and the New Jersey bank of the river to act together vigorously to protect the welfare of both. Unfortunately local interests and political divisions still stand obstinately in the way—they are in some ways harder to overcome than the tremendous physical obstacles of geography. One may gain a hint of what these are when it is said that the more far-sighted authorities interested in the city plan are coming to feel that much of the difficulty in the whole complex

problem of New York City is caused by the congestion in Manhattan Island. Manhattan Island has many functions. It is a large part of the Port of New York, which carries a far larger proportion of the shipping of the United States than any other Port; it is a great railroad terminal and distributing center for freight of the adjacent country by rail and motor; it is a great market center; and besides these it carries on much manufacturing—all in addition to its vast activities in finance, retail selling, real estate, its intellectual and recreational activities and its own local necessities. The long, narrow island can hardly hold them all, and they are all growing amazingly. Confusion is great, is increasing, and causes economic loss. The situation is becoming intolerable.

Hence the relationship of both tunnel and bridge to this congestion of Manhattan Island is most significant. In fact, it may be more important even than its more obvious usefulness, that of providing better communications across





ALFRED C. BOSSOM  
ARCHITECT 650 FIFTH AVE.

PROPOSED VICTORY BRIDGE OVER THE HUDSON. ALFRED C. BOSSOM, ARCHITECT.



MAP SHOWING CONNECTION BETWEEN THE PROPOSED VICTORY BRIDGE (HERE CALLED "MEMORIAL BRIDGE") AND THE EXISTING BRIDGES OVER THE EAST RIVER.

the Hudson River between New York and New Jersey. Here one must be guarded in making sweeping statements as to so complicated a problem, with the changes that the future may bring to it, which cannot all be foreseen. Still, notwithstanding the uncertainty as to the future, it may be said that these tunnels and bridges may be the first step in the decentralization of Manhattan Island. In other words, there are many activities now carried on in Manhattan, such as manufacturing, warehousing and shipping, that could just as well be carried on outside the island, *provided* quick transportation could be had in and out of the city. Time, in transportation, even more than distance, may separate the parts of a city, and today it often takes more time and costs more—even where motor transport is called upon—to bring freight from New Jersey terminals into New York City than it does to bring this same freight from Pittsburgh or Buffalo to New York

on the railroad. The delays on ferry and lighter, due to congestion, run into hours, often even more than a day in a trip back and forth across the river by motor. Thus it is no exaggeration to say that the New Jersey communities near New York Bay are, in the matter of freight communication, as far away from Manhattan Island as they are from Philadelphia or even from Baltimore or Boston. Under present conditions, when quick delivery is required, goods must be made or stored in Manhattan. It is this situation that the bridge and tunnels should help relieve through providing quick transportation and allowing business to locate outside Manhattan Island.

An idea of these factors will aid in appreciating some of the features of design of the proposed Victory Bridge. The floor of the bridge is very high above the water. This is, of course, required by the War Department, in order to insure clearance for ocean-going ships.



But this height has the additional advantage of allowing the New Jersey end of the bridge to rest upon the Weehawken heights—the continuation of the famous Palisades—that stand back about one mile from the pierhead line. This ridge has been another natural barrier, parallel to the river and, with it, dividing New York City from New Jersey, interrupting communication. So, by placing the approach to the bridge on its top, the obstacle of the ridge is in large part overcome. The railroad tracks and other types of transport carried by the bridge may discharge directly into the big trunk railroads and into their terminals and classification yards, which are located in the Hackensack meadows west of the ridge. On its New York end, the bridge abuts at a point near the western approaches of the three East River bridges referred to, as the map shows. This arrangement will facilitate traffic between New Jersey and Brooklyn. In time, if such cross-traffic should cause too much congestion in the streets, it could be accommodated in short traffic tunnels. One point, however, concerning the Manhattan end is not made clear by the sponsors of the bridge; that is, what function will be performed by the ten railroad tracks arriving this part of New York City?

From these considerations one gains an idea of the complex character of this colossal scheme. Other details there are, such as a system of warehouses, stores, commercial buildings, etc., to be constructed under the approaches of the bridge, at each end. The space in the towers can also be utilized.

But, we may well ask, will not the memorial ideal be swallowed up in this fast scheme of transport and of commerce?

Such a question is indeed pertinent. One may acknowledge frankly that unscrupulous interests have used the sacred symbolism of the memorial in more than one case as an alluring disguise for a materialistic business "proposition," that could not succeed otherwise. Certainly, the objection to any utilitarian character in a memorial is a sound one. There are, however, peculiar cases which meet this objection, and a colossal bridge is one. This bridge is, besides, intended as a monument to Victory rather than as a memorial. Who has not felt his imagination kindle as he crossed a great bridge suspended over the mouth of a river at a huge port, its water teeming with great ships from all the harbors of the seven oceans, and little craft; its banks lined with splendid docks, behind them towering the skyline of a city? To a myriad of humans that traverse the East River Bridges each day, the trip is always an event which lifts them a little above the materialism of life. Is not this exaltation just the impression that a monument of victory should give? There is no better symbol for a memorial than a tower, and the two huge pylons, designed by Mr. Bossom, that support the suspension cables, are intended to give the memorial character inseparable from a bridge of victory—one tower devoted to New York and one to New Jersey, and to be used for no other utilitarian purpose than their function of supporting the cables. Such towers are fit memorials, both in their splendid monumental architecture and in their incomparable position astride a great river where it enters the sea—the portals of a huge city and of two states.



CEILING TO LIBRARY—RAVENS-  
COURT PARK, LONDON, W.



# *English Architectural Decoration*

## *Text and Measured Drawings* by *Albert E. Bullock*

### Part XV-3. The Adam Period (Continued).

THE English people have a natural sense of adoration for the prime organizer or master mind in any movement to the exclusion of many who may have an equal right of recognition. This is especially patent when treating of architectural biography.

Inigo Jones was believed to be the originator of the design for the quadrangle of St. John's College, Oxford, until it was proven that there was no stable evidence for his having visited that city during any period of his career. Hubert le Sueur was next associated with this work, because he was known to have executed the bronze figures in the niches over the colonnade, after which it was stated to have been undoubtedly designed by Flemish hands, owing to the character of the detail. No one, however, appears to have suggested the possibility that the architect was in point of fact the master mason who built Cornbury, erected the porch to St. Mary's Church and the arches to the physic garden, and who had, moreover, spent some years in Holland prior to the creation of his work-shop in Long Acre, London. This mason, Nicholas Stone, had an agent in Oxford in the person of his cousin, Gabriel Staces, with whom he was in continual communication for the supply of material for Cornbury and many other works there, including mural tablets erected in the various colleges, as Merton, Christ Church, etc., and had employed Le Sueur on more than one occasion.

Stone carried out his own designs for additions to churches in Amsterdam when working with his father-in-law, Pieter de Keyser, and was quite capable of acting in both capacities.

The biographers of Inigo Jones have assumed that all architectural works ex-

ecuted by Stone were originally designed by Jones.

As with Inigo Jones, so it is with Sir Christopher Wren and Robert Adam.

Darley competed with Adam in the execution of much work of equal merit, and Carter, a contemporary of Chippendale, anticipated the style which subsequently developed into the Adam manner. These men culled their information from the same sources, namely, France and Italy, and in particular the publications of researches, designs of men like Cauvet and engravings of that inspired genius Piranesi. There were also many French decorators of the period whose works were known in England, like Bellanger, Berthault, Krafft and Sombre. Some of their features were directly plagiarized by English decorators, especially the works of Berthault and Lemoine le Romain.

Inspired as was Inigo Jones by the works of Palladio and the writings of Vitruvius, Robert Adam was in like manner subject to the influences of Piranesi. This engraver was remarkable for his original compositions of architectural subjects, depicting ruins and restoring them by the medium of his versatile nature. In details his motifs formed the fountain head of the Adam period of art, from the ram's head and winged griffins to the fluting and beading which accompanied the Greek honeysuckle ornament that adorns most of the work of the age.

Yet this was by no means the only source of inspiration. There is no doubt that Raphael's gallery at the Vatican and the fifteenth century work from the Cathedral at Pavia received more than passing notice by the eighteenth century designers.

Some of the unexecuted designs of Sion

House were conceived with the assistance of Piranesi, whose grand manner was the source from which the general plan appears to have been evolved.

Nor was Adam the only English architect who was directly influenced by the works of Piranesi, the publication of which dated from the middle of the century. Born in 1720, he published his first engravings at the age of 21, and continued to execute most elaborate work until his death in 1778, at the rate of one a fortnight. His series of chimneypieces and vases indicate a highly technical skill, both in engraving and design, with a knowledge of the limitations of the subject; while his representations of the various palaces and ancient ruins of his country are very truthfully portrayed.

Robert Adam and his coterie of Italian assistants would have immediate access to these designs, owing to the friendship which existed between the two men; and when James Adam visited Italy Piranesi was in his fortieth year and at the height of his career.

What perhaps is most evident to the student of the history of the styles of interior decoration is the unanimity with which the vogue developed in far reaching districts of England.

Mention has already been made of John Wood of Bath, who designed Buckland in Berkshire for Sir Robert Throckmorton and Stanlinch in Wiltshire for Mr. Henry Dawkins, apart from his extensive works in the city of Bath. While John Carr of York executed Thoresby Lodge, Nottinghamshire, for the Duke of Kingston; Oakland House, Cheshire, for Sir Peter Leicester; Harwood House, Yorkshire, for Edwin Lascelles, and Constable Barton, Yorkshire, for Sir Marmaduke Wyvill.

Of the lesser known men we have S. Leadbetter, the author of Newnham, Oxfordshire, the seat of Earl Harcourt, and J. Sanderson, who was associated with Smith (probably of Warwick) in the erection of Kertlington Park, Oxfordshire, for Sir James Dashwood, and Stratton Park, Hampshire, for the Duke

of Bedford. J. James was the architect of Sir Gregory Page's seat at Blackheath, Kent, and R. Morris, the author of Thomas Wyndham's House at Hammer-smith, was associated with the Earl of Burlington in the designs for Kirby Hall, Yorkshire, for John Thompson, Esq.

These last mentioned buildings were executed earlier in the century than the period with which we are now dealing; but the publication of the designs in the fourth and fifth volumes of "Vitruvius Britannicus" were intended to supplement the first three volumes by Colin Campbell as a guide to architects of the standard works of renown.

Books dealing with furniture were scarce in the eighteenth century. Sheraton states that he had seen one which was apparently published before Chippendale's "Director," which latter appeared in 1754. The third edition of Thomas Sheraton's book, "The Cabinet-Makers and Upholsterers Drawing Book," in four parts, saw the light in 1802, and contains many designs by Sheraton and G. Terry executed in 1793 and 1794. This was followed by the Leeds and Manchester Price Books, the latter appearing in 1810, with drawings by Shearer, Hepplewhite and Casement; after which numerous works were placed on the market dealing with various features of the house both modern and ancient. In 1834 Shaw published his series of measured drawings of Jacobean houses, which is a standard work of great value; while J. C. Richardson was an indefatigable worker in the same period of research. His large collection of drawings, housed in the Victoria and Albert Museum, are finished with great care and afford a valuable addition to the student's library.

In 1879 Charles's "Compiler" was published, embracing the work of many of the better examples appearing in previous publications, including designs by Pergolesi, R. Adam, W. & J. Pain, W. Thomas and certain French architects, with a view to putting on record in one volume the chief characteristics of the



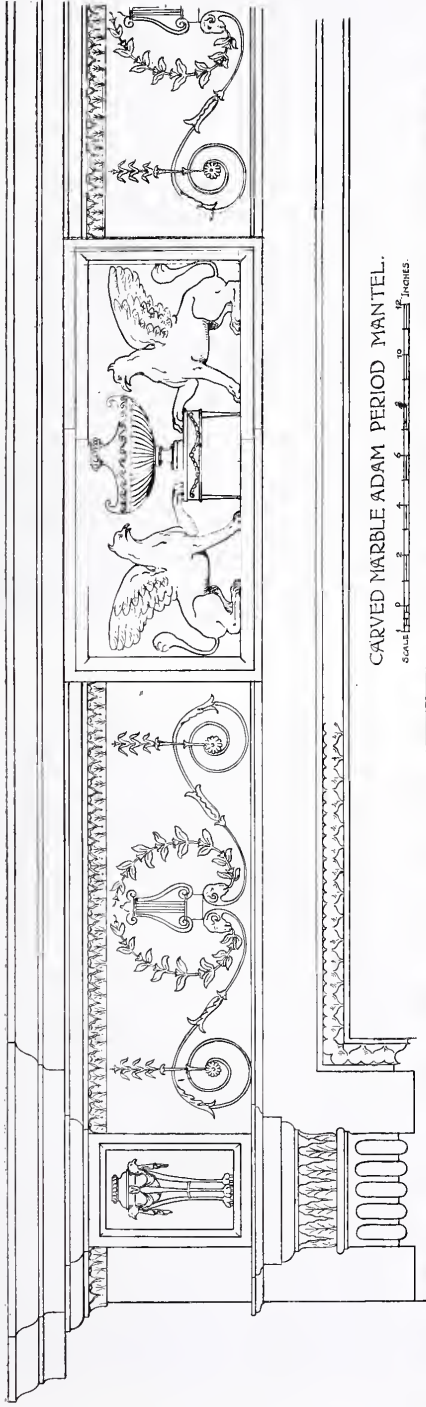

CARVED MARBLE ADAM PERIOD MANTEL.

SCALE IN FEET AND INCHES.

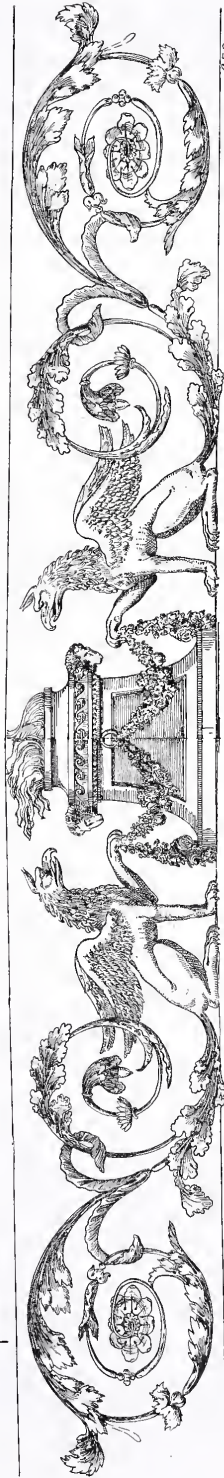

FRIEZE ORNAMENT BY T. SHERATON.

FRIEZE ORNAMENT BY SHERATON AND  
CARVED MARBLE ADAM PERIOD MANTEL.

SCALE IN FEET AND INCHES.



STAIRCASE CEILING—BEACON HOUSE, PAINSWICK, GLOUCESTER.

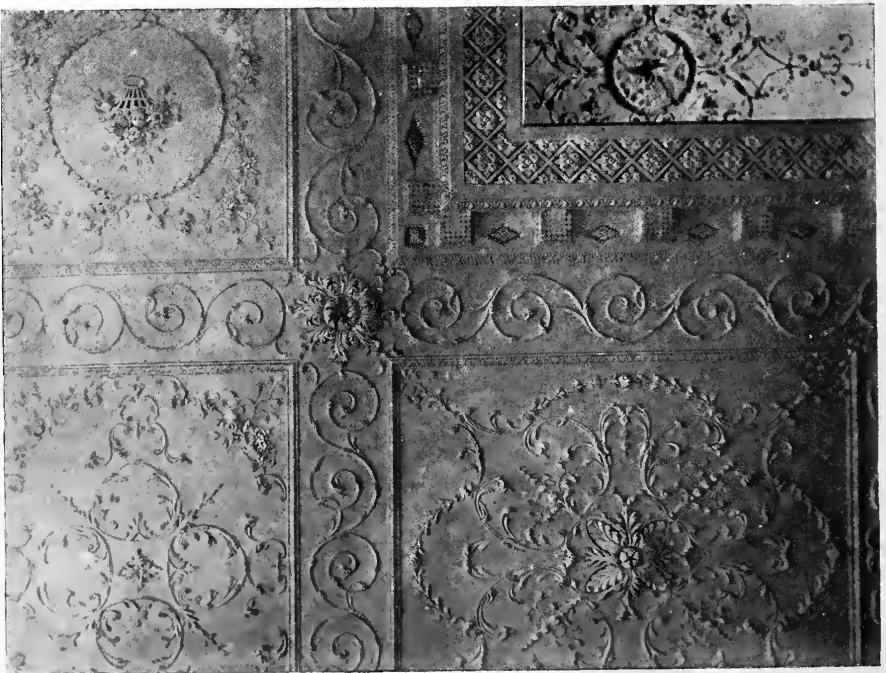

HALL CEILING—BEACON HOUSE, PAINSWICK, GLOUCESTER.



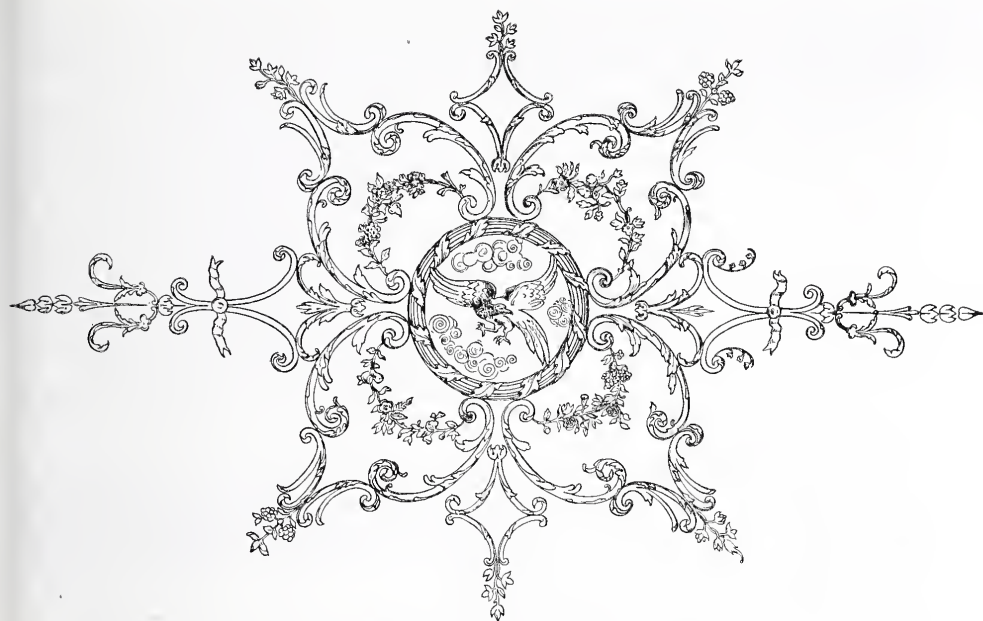

Scale 1 2 3 feet

STAIRCASE CEILING AT  
BEACON HOUSE · PAINSWICK.

STAIRCASE CEILING — BEACON  
HOUSE, PAINSWICK, GLOUCESTER.

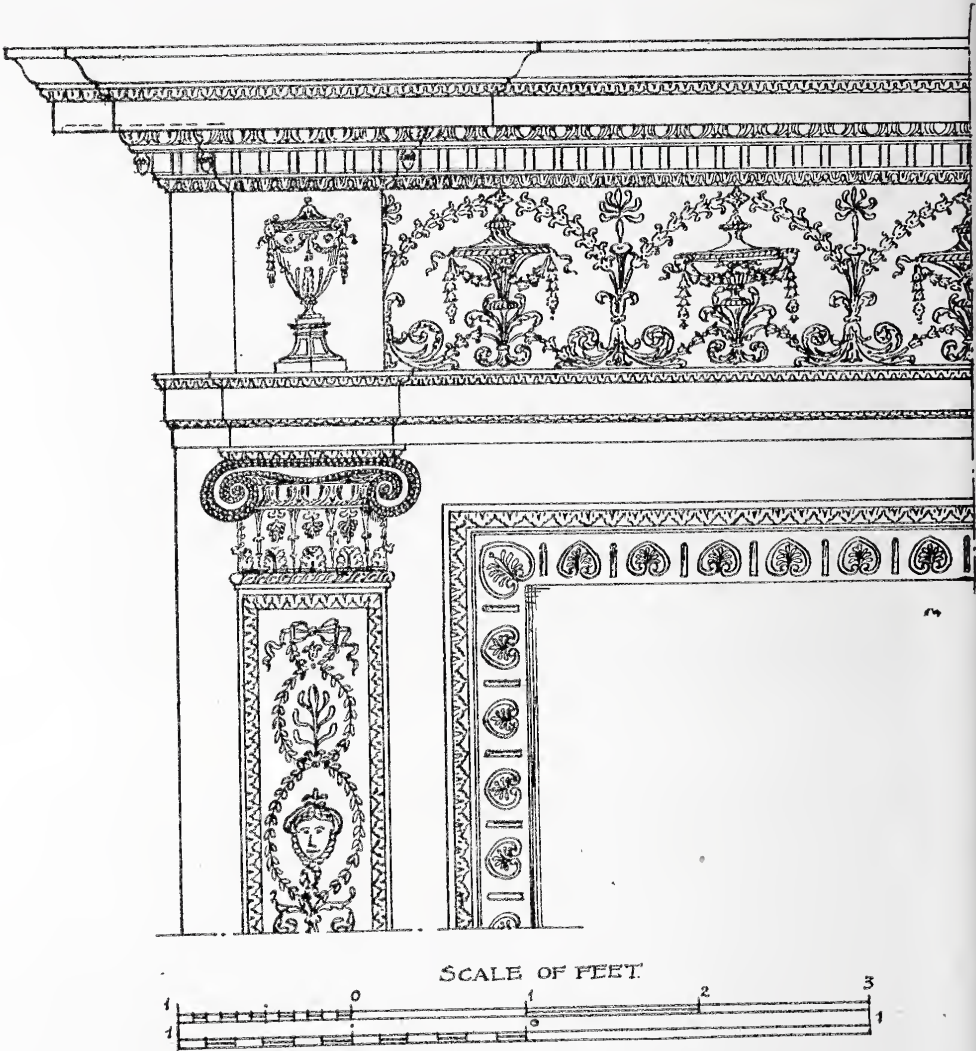

DETAIL OF CHIMNEYPIECE.  
DESIGNED BY PERGOLESI.



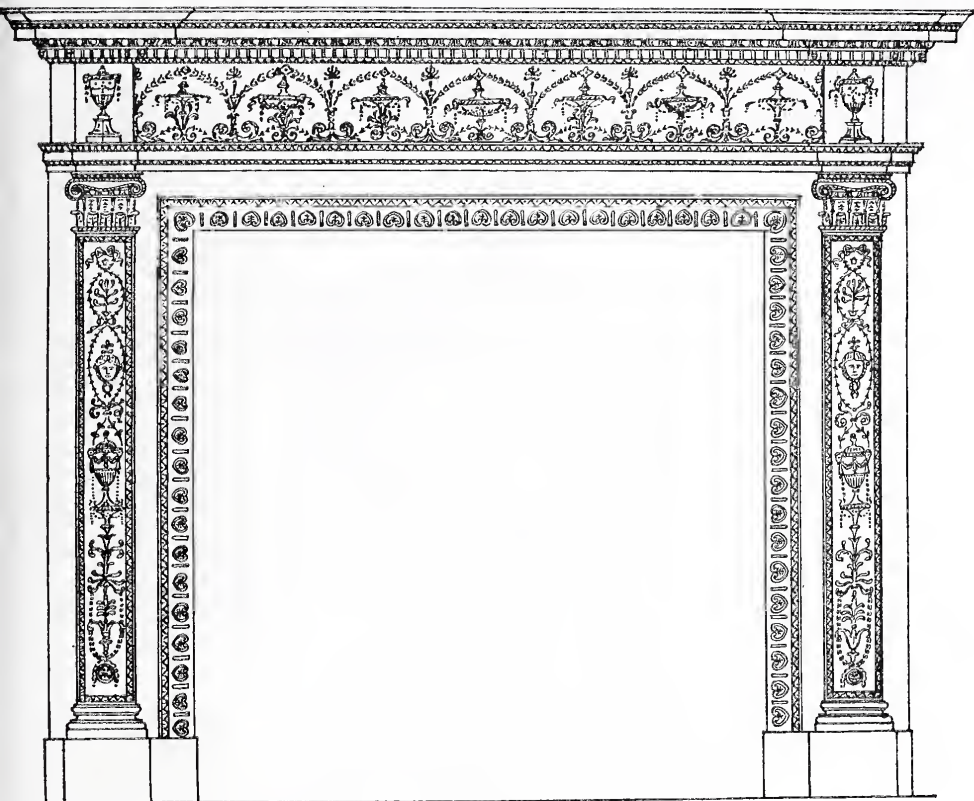

CHIMNEY-PIECE DESIGNED BY  
PERGOLESÌ 1784.

CHIMNEYPIECE DESIGNED BY PERGOLESÌ.  
(FOR SCALE, SEE OPPOSITE PAGE.)

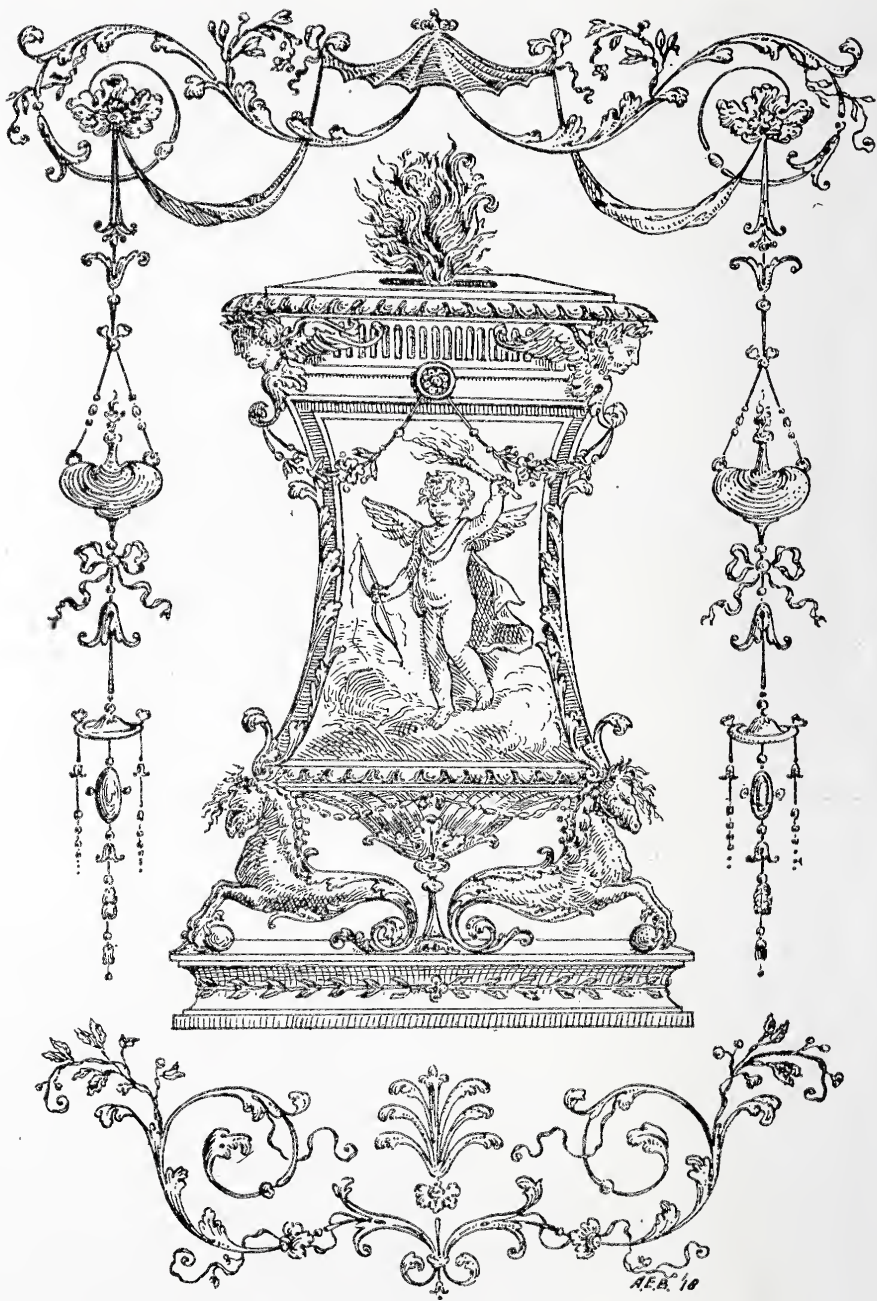

*DESIGN BY PERGOLESÌ. 1784.*

PANEL DESIGN BY PERGOLESÌ.



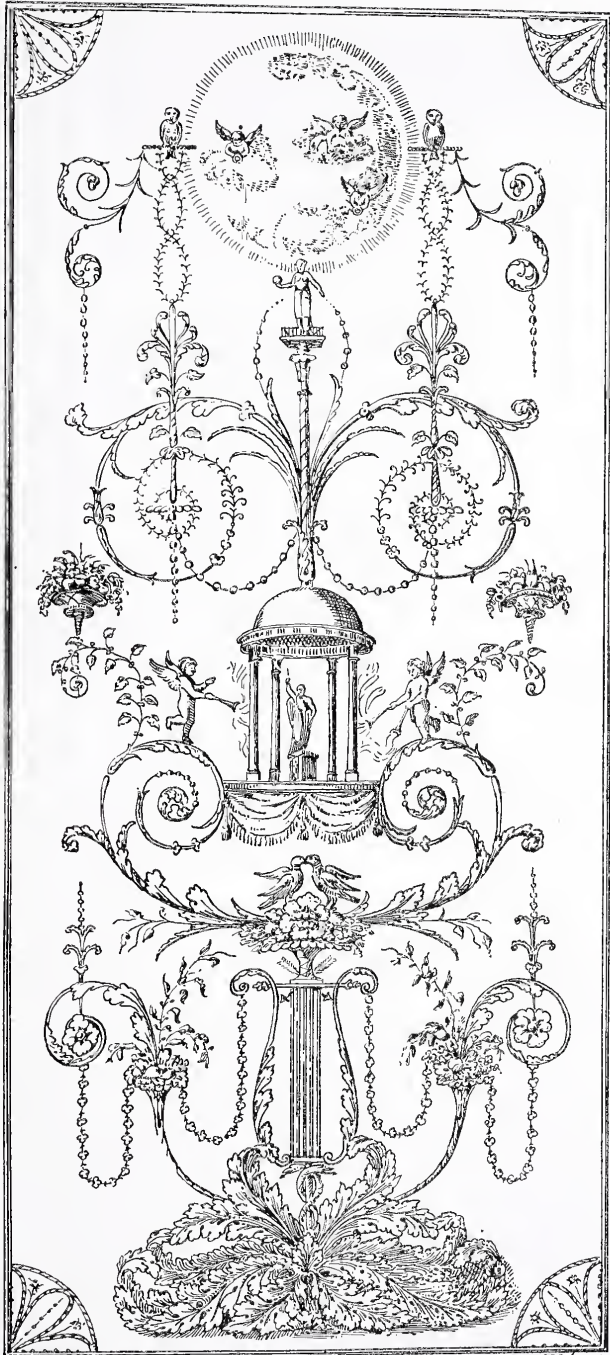

T. Sheraton Del. 1793.

J. B. Truel. 1790.

ORNAMENT for a PAINTED PANEL

PANEL DESIGN BY SHERATON.



CORNICE AND FRIEZE, ADAM PERIOD, ABOUT 1775. IN VICTORIA AND ALBERT MUSEUM.

more notable designers of the eighteenth and early years of the nineteenth century.

The illustrations which accompany this article are drawn from the latter work and Sheraton's book in order to exhibit the peculiarities of various artists who assisted or followed in the wake of Robert Adam.

The particular skill of Pergolesi lay in the practicability of most of his designs, together with a certain artistic expression which was peculiarly his own; while men like W. Thomas, N. Wallis and W. & J. Pain carried out the Adam manner with evident zest. Works of the Chippendale era by Ince and Mayhew, and Abraham Swan, although exhibiting a sound knowledge of the orders of architecture, gave expression to a piracy of French cult and plagiaristic tendency in the incorporation of certain features of the earlier styles. In dealing with ornament the play on the husk motifs is noticeable with the work of Swan, whose style in execution is very like the two

Georgian rooms in the Victoria and Albert Museum, which have already been illustrated in these pages. Ornament for ornament's sake would seem to have been the theme of this era of decoration.

The ram's head and husk festoon figure in some of the designs of James Gibbs as early as 1739, who had among his vases some hexagonal shaped designs anticipating work which was executed similarly during the Adam period. Gibbs was in point of fact a particularly skilful designer from a decorator's standard; and although his cartouches are somewhat heavy and lack the grace attending some earlier examples, his other features were for the most part applicable to decorative use and obviously appropriate to the general work of the period of its vogue. It was Chambers's publication which brought about the pagoda like finish in China cabinets, sideboards and the like, as with the ecoineurs or angle "what-nots" (as they were called in the Victorian era).

The early years of the nineteenth cen-



... century witnessed the Greek revival which Cockerell produced in its fullness, Sir John Soane with certain modifications and predilections of his own, and Thomas Hope with the addition of Pompeian and Egyptian features. The phrase, however, was not successful in producing a new style, each strove with Chinese exactitude to reproduce given objects with the evident result that inventive convention became a lost art, and a very confused state prevailed that terminated with the type of work which produced the 1851 Exhibition of London and the Paris Exhibition of 1878, when the panelling became heavily molded and the

panels were carved, inlaid or painted with much elaboration but little soul.

The redeeming features of the century were the genius of Alfred Stevens in decoration and the garden work of George Devey and Sir Charles Barry.

Had it not been for men of this stamp, the century would have been devoid of artistic expression other than what was produced by the Gothic revivalists and the architects who laid out the West End of London on sound principles of town-planning on the one hand, and those who were actively measuring and executing reproductions of examples of earlier periods.



MODERN REPRODUCTION OF MIRROR IN STYLE OF INCE & MAYHEW.

## WINNING DESIGNS *in the* COMPETITION FOR THE FELLOWSHIP *in* ARCHITECTURE OF THE AMERICAN ACADEMY *in* ROME



THE prize designs published herewith display a soundness of conception and a maturity of execution which one hardly expects to find among young designers who are scarcely a year out of the architectural schools. Indeed, the first prize design challenges a comparison with the better work of experienced architects. The designs picture a "Memorial to a Great Man," who, though not mentioned by name in the program, could be none other than Theodore Roosevelt. The monument is planned for a site on an eminence, the site about five hundred feet in diameter and the building not over two hundred feet in its largest dimension; and it is to commemorate in a triple manner services in citizenship, in science and in letters. The interior was to be designed as a composition of painting, sculpture and architecture, with mural paintings and sculpture symbolizing achievements in science and in letters.

A very simple program; and because it is so simple, it inspires—if the designer has the power—a monument of tremendous single impression. When such unity is rendered expressively in beautiful form, architecture has the essentials of a masterpiece. How finely, even exquisitely, these qualities can be symbolized as a memorial may be perceived in the illustrations of Mr. Smith's winning design—in the plan, with its one simple, stately chamber; in section, with its mural and sculptural decorations; and, in elevation, with its splendid classic mass and modeling reminiscent of the Mausoleum of Halicarnassus of Hellenic Greece. It expresses the triple character of the memo-

rial, yet this division is so carefully subordinated that the singleness of impression is not weakened. In the other designs the threefold purpose has brought something of diffusion.

The author of this fine conception is Mr. James Kellum Smith, A. B. Amherst and A. M. University of Pennsylvania, an American artist of American ancestry and American art education. He is at present in the office of McKim, Mead and White. Of much the same character are the winners of the second and third prizes, Leland King Cardwell, Chicago Art Institute, and Warren L. Hindenach, B. S. University of Pennsylvania and M. S. Harvard. To architects this success of native artists may cause no surprise, but it may well be noted in certain art circles outside architecture where the myth has grown up that American art is possible only if produced by aliens. Like many another nineteenth century assumption regarding art, this myth takes little account of fact, which appears to be that, no matter how great any art may be, or how cosmopolitan may be its appeal, it is at the same time a symbol of native and local flavor. Unless it is native and local it can hardly be fundamental and true and vivid—and it certainly cannot have the personality of craftsmanship, which is always racy of a particular locality.

The American Academy in Rome may well be congratulated on the excellence of this competition for its fellowship in architecture, and its sponsors may feel that their fine ideal of art education is bearing fruit.



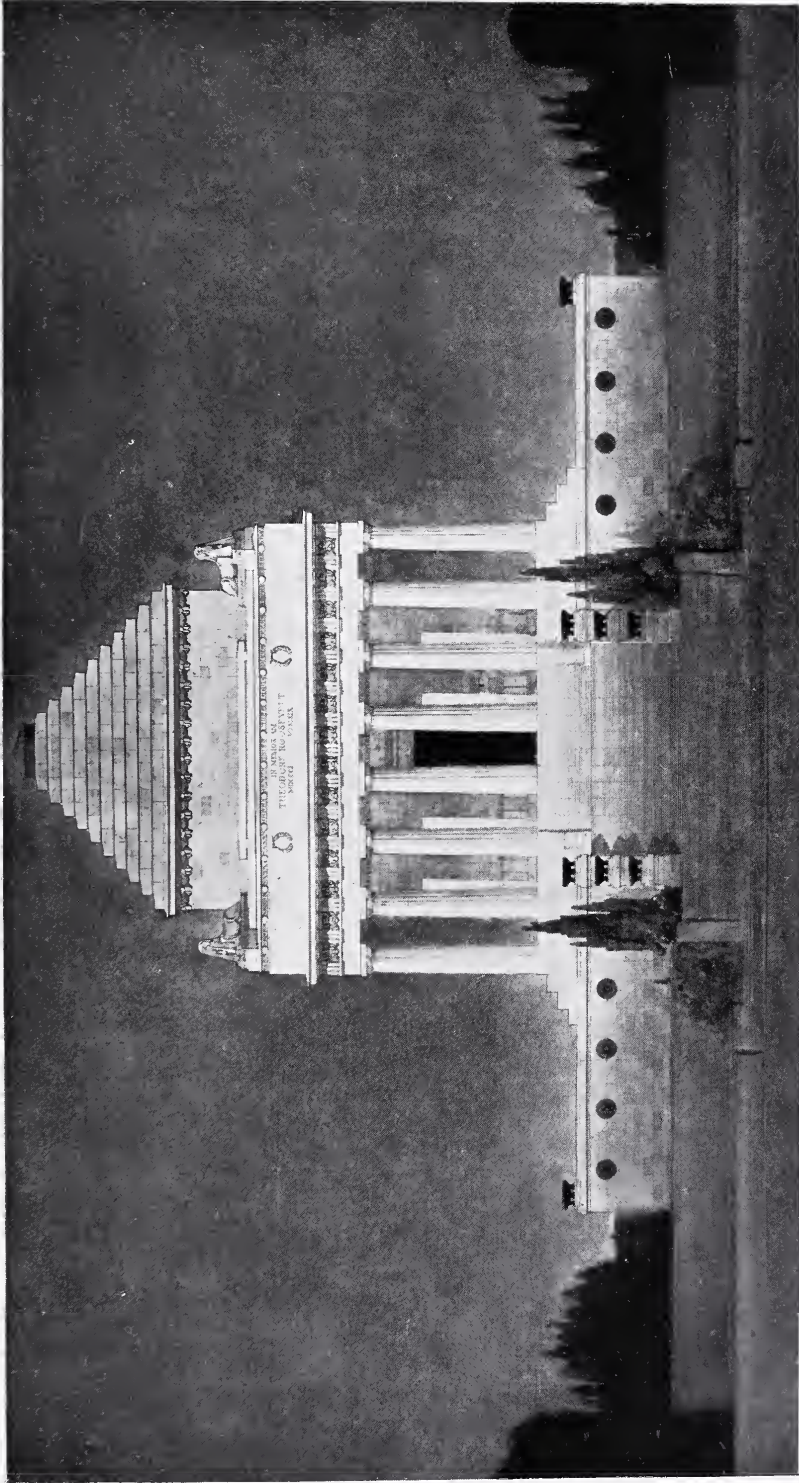

ELEVATION—FIRST PRIZE DESIGN, BY JAMES KELLUM SMITH. COMPETITION FOR THE FELLOWSHIP IN ARCHITECTURE OF THE AMERICAN ACADEMY IN ROME.

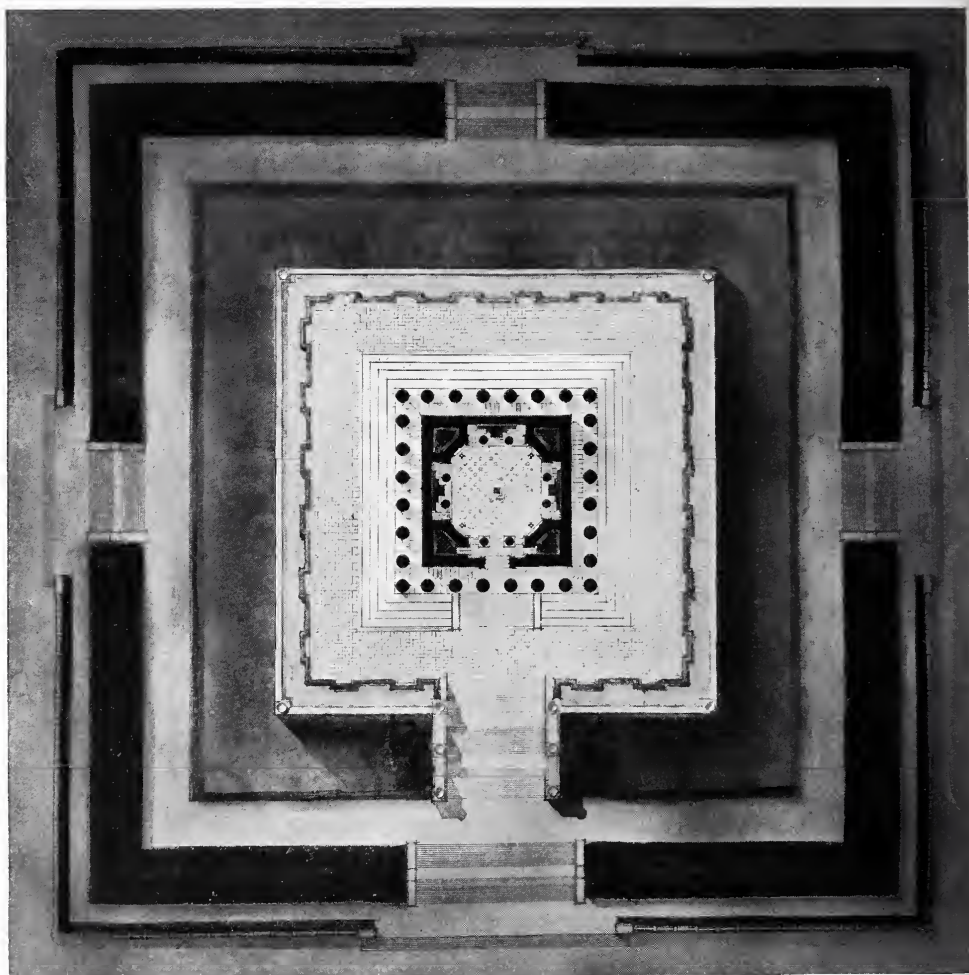

PLAN—FIRST PRIZE DESIGN, BY JAMES KELLUM SMITH. COMPETITION FOR THE FELLOWSHIP IN ARCHITECTURE OF THE AMERICAN ACADEMY IN ROME.



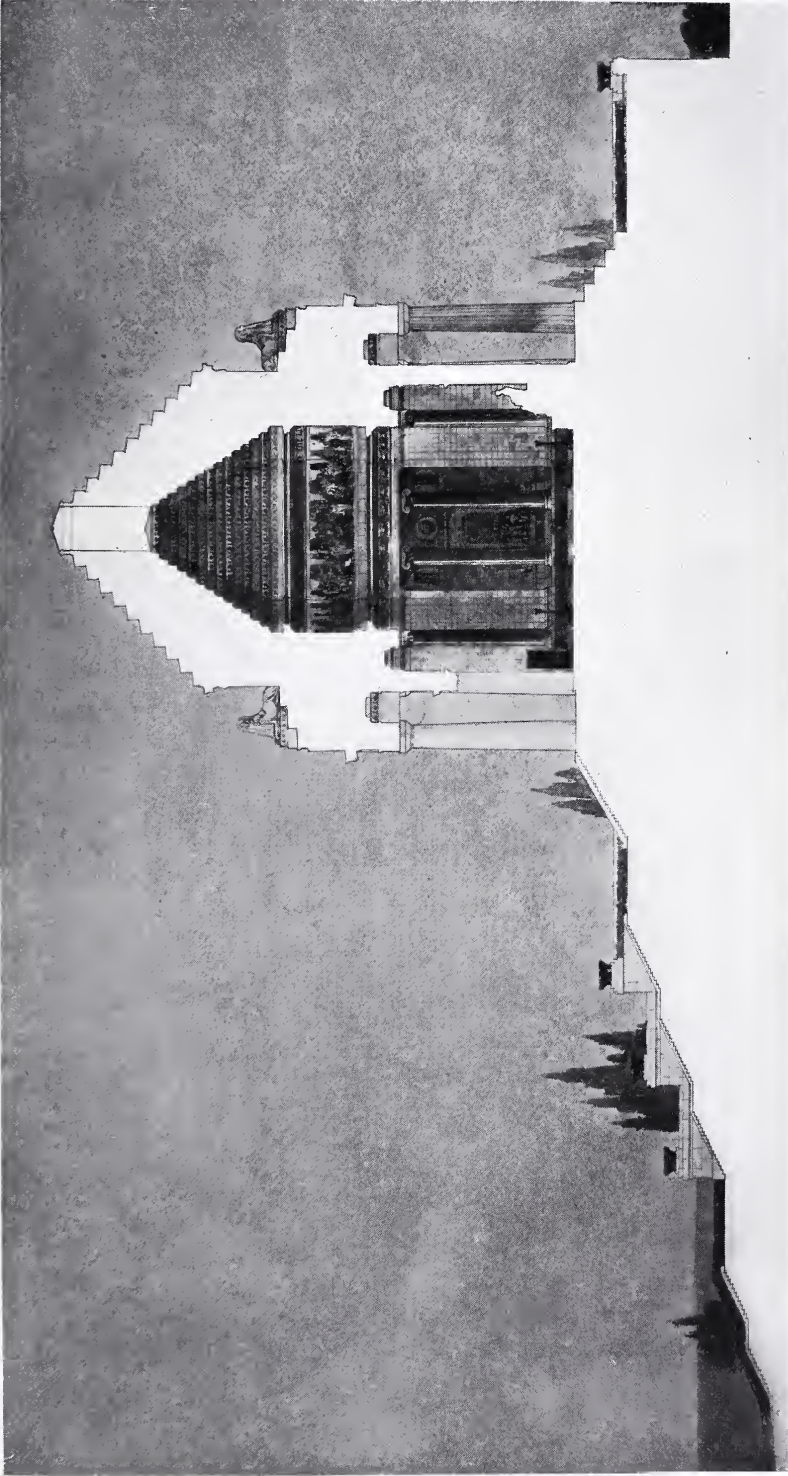

SECTION—FIRST PRIZE DESIGN, BY JAMES KELLUM SMITH. COMPETITION FOR THE FELLOWSHIP IN ARCHITECTURE OF THE AMERICAN ACADEMY IN ROME.

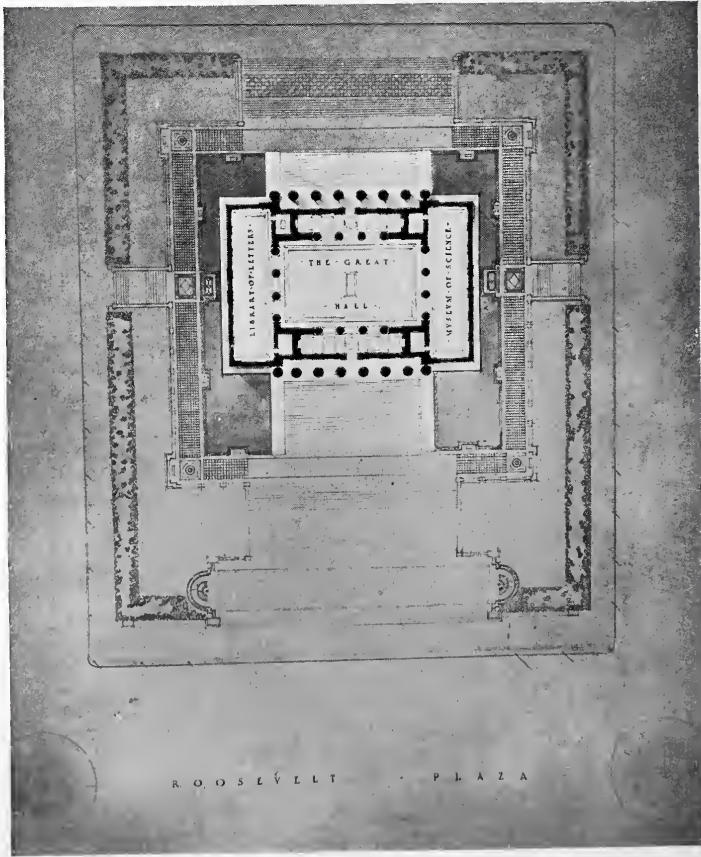

ELEVATION AND PLAN — SECOND PRIZE DESIGN, BY LELAND KING CARDWELL. COMPETITION FOR THE FELLOWSHIP IN ARCHITECTURE OF THE AMERICAN ACADEMY IN ROME.



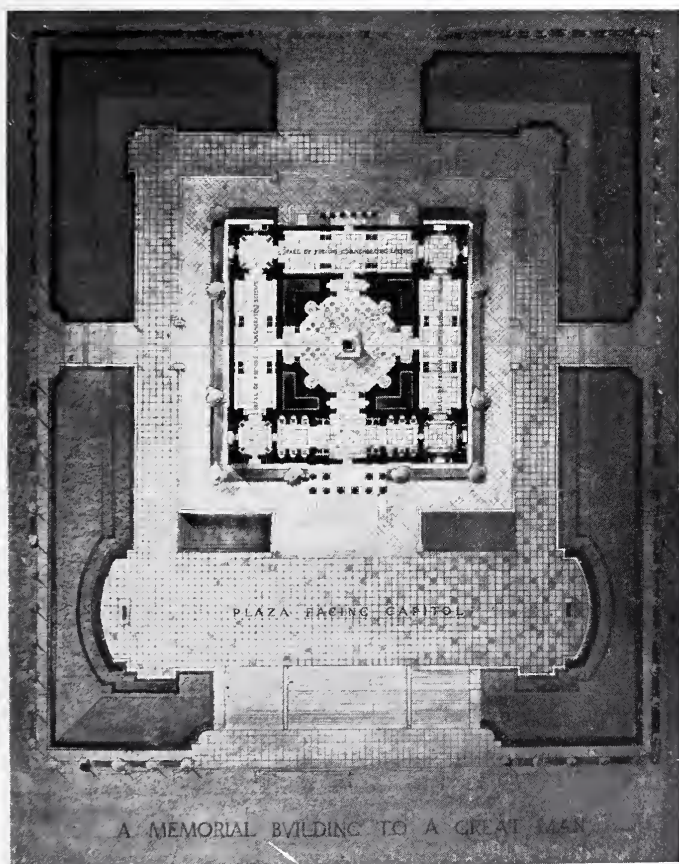
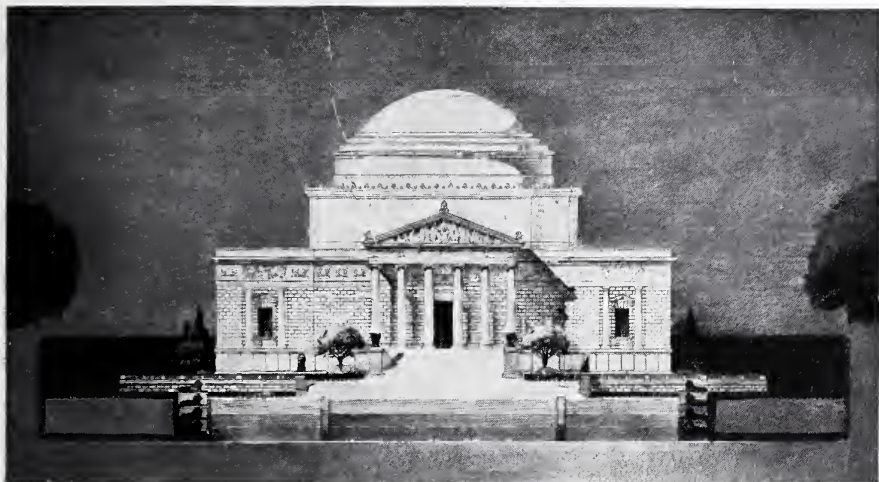

ELEVATION AND PLAN—THIRD PRIZE DESIGN,  
BY WARREN L. HINDENACH. COMPETITION  
FOR THE FELLOWSHIP IN ARCHITECTURE  
OF THE AMERICAN ACADEMY IN ROME.



LIVING ROOM—RESIDENCE OF NATHANIEL  
J. GUERNSEY, ESQ., GREENWICH, CONN.  
ELECTUS D. LITCHFIELD, ARCHITECT.



# SOME PRINCIPLES OF SMALL HOUSE DESIGN

By  
JOHN TAYLOR BOYD, JR.

## *Part IX Interiors-Continued*

THIS chapter, which is the third one on interiors of the series, concerns that part of the art of interiors known as "interior decoration." Interior decoration is the art of furnishing and of finishing interiors, and in practice it usually covers the scheme of color and of finish, and the arrangement of furniture, hangings, art objects and other decorations. It is true, the ablest designers do not thus restrict the meaning of the term "interior decoration," but these are still in the minority. Too commonly, interior decoration is an art separated from the rest of the design of the interior.

It is not necessary, even if needs of space did not forbid, to cover in these pages the whole range of interior decoration. The principles of this particular art specialty are now well established—or re-established, it is more correct to say—in the United States, both in actual designs and in excellent writings. Consequently, only certain truths regarding them need be emphasized. These are, first, the relationship of interior decoration, as commonly practised, to the whole art of interiors in the small house; second, certain principles of style and good taste in interior decoration; and, third, the more detailed description of the principles of design that underlie interior decoration in all its multitude of arts and crafts. For this latter, it will be necessary to refer the reader to the better technical writings on interior decoration. As regards the first two subjects much has already been set forth in previous articles of the series.

If one would state the whole character of interior decoration in a sentence, one might say that it concerns the fundamental aesthetic principles common to all the arts in their specific application to the great variety of arts and crafts which are combined in interior design. These principles, under the name of Pure Design, should be understood, because they are of vital importance in the modern world of art. In the confusion of the arts, which have become so diversified, so specialized, so out of touch one with another, drifting away from the main current of the stream of art, a great need has arisen to seek again the fundamental principles of beauty. Since beauty can hardly be formulated mathematically, design has been studied as the thing nearest to it. Through knowledge of the fundamentals of design, it is hoped to reestablish art on its ancient bases of soundness and coherence. This task of formulating basic principles is now well under way, and, in some arts at least, the practical application of such principles is now well understood.

The progress towards a return to the normal in art is very recent. Mrs. Edith Wharton in her book, "The Decoration of Houses," Scribner's Sons, first published in 1897, says in her concluding chapter, "Many hold that in questions of taste *Gefühl ist alles*; while those who believe that beyond the oscillations of fashion certain fixed laws may be discerned have as yet agreed upon no definite formula defining their belief. In short, our civilization has not yet devel-

oped any artistic creed so generally recognized that it may be invoked . . . without risk of misunderstanding." Mrs. Wharton, however, excepts architecture and the allied arts, because in them "beauty depends on fitness, and the practical requirements of life are the ultimate test of fitness." Twenty-five years has made this latter statement seem almost primitive. The former, however, was altogether prophetic. For, in view of Mrs. Wharton's standing in art and letters, and her wide knowledge of European thought, one must suppose that she spoke conservatively in thus describing the want of basis and of purpose in late nineteenth century art.

When a need is pressing in the world, some one usually arises to meet it. Still, it is surprising that, a few years after Mrs. Wharton's statement, Mr. Denman Waldo Ross, Lecturer in Fine Arts at Harvard University, completed a formulation of principles of design, as the aesthetic principles common to all the arts irrespective of time or conditions.

His system, with its clear statement and clear terminology, but slightly altered since, has stood the test both of theory and of practice. His theory of pure design has been recently applied to the art of interior decoration, and it forms the basis of the best writings on the subject. If the reader would study these writings with discrimination, he should understand something of their basic theory; and, equally important, since a formulation of theory is only a means to an end, he might well know its place in the trend of thought of the times.

The twentieth century, in its task of restoring order in the nineteenth century confusion in art, was forced to analyze the causes of disaster. In older, more spontaneous times, these principles were accepted instinctively, as a matter of experience, and were handed down in the form of customs and habits and understandings, in the lore of art, from generation to generation, from groups to groups, and from artist to artist. Furthermore, the arts were not so sepa-



LIVING ROOM—COTTAGE IN CONNECTICUT.  
Murphy & Dana, Architects.





LIVING ROOM—COTTAGE IN CONNECTICUT.  
Murphy & Dana, Architects.

rate as now, being instead mostly joined with architecture. Artists were often masters of several arts at once. Hence there was no great need either to detach a body of abstract principles fundamental to all the arts, nor to distinguish formally between theory and practice in any one art. The unity of brain and hand and heart was absolute. This situation is the normal one, and the one which the twentieth century is striving to reestablish. Already it is far along on the journey towards the goal.

To appreciate the recent progress it is necessary to understand how far we have advanced beyond our starting point in the last century. We now see, I think, that the nineteenth century was an age of revolution—revolution in all respects, in thought, politics and in the mechanical and economic structure of society. In such an abnormal setting art was bound to be abnormal. How could art flourish in an age of unrelated specialist experimentation and in the chaos of theories arising therefrom!

Could art be sound in a century given over to extremes of individualism, of egotism, of an indiscriminating naturalism; in an age that was addicted to a spurious cosmopolitanism and to a search for programmes of philosophical absolutes! How could a sense of form and of order and of reason, or wholesomeness and spontaneity—which are at the basis of art—be retained in such abnormal conditions!

But if the culture of the nineteenth century was unfavorable for art, so also were the economic and mechanical upheavals of the period. These are still in process, though some keen observers are willing to say that present extremes cannot continue much longer. What is important to realize is, that the existing complication and subdivision of the mechanical structure of society cause an insidious complication and subdivision of the thought produced in it. Thought is "pyramided," as well as finance or government. This tendency towards an over-complicated, top heavy culture should be



LIVING ROOM—HOUSE AT LLOYD'S NECK, L. I.  
Murphy & Dana, Architects.

counteracted in every possible way, if we are once again to attain the normal.

Thus it is not surprising that, in art, in the nineteenth century, design—and beauty—dropped away until it became no more than an incident, or else disappeared altogether. Conflicting views on art sprung up. Art was a mysterious personal power of extraordinary individuals—a divine gift to favored apostles, or, in the opinion of some, a species of rare mental disease. Art was a matter of reviving historic styles, or of the looting of them all under the labels of “eclecticism” or of “cosmopolitanism.” It was the expression of the age or of the world spirit. Sometimes it was a by-product of literature. In architecture, it was often a phase of mechanics. Thus you will find that much of the nineteenth century art criticism is based on almost any other premises than the essential ones—pure design, and style. Amid all their disagreements and pursuit

of side issues, artists and critics were usually willing to forsake the worship of art for the delights of personal combat, in upholding the theories of some loved master against all comers.

The present temper is to seek agreement on essentials. But the few survivors of the old guard will not surrender, and it is not surprising that they who hold a vested interest in the occult and individualistic conception of art should resist valiantly any attempt to regain the normal. As stated above, the aim is now to separate from its applications in style and technique in the various arts a body of underlying theory that shall guide the arts and that shall harmonize art as a whole. This was not so necessary in simpler ages, when these principles were more or less consciously grasped; but now in our complex times, when the many arts are so separated and so expertized, it seems indispensable. Otherwise the economic pressure of business would de-





CORNER OF WRITING ROOM—FARMHOUSE  
OF MRS. W. M. RITTER, MANCHESTER,  
VT. MURPHY & DANA, ARCHITECTS.

stroy art, by shattering it into bits with the principle of the division of labor.

Thus pure design is pure theory, and therefore it does not take into account utility or expression or function or style, or even the technique of any one art. Though comparisons are risky, it may be said that Pure Design is to art

in the individual artist. In other words, the aim of the artist is to interpret these universal principles of art in terms of his particular problem and of the situation in which he finds himself. And, most necessary above all else, the process should not be a cold, intellectual, analytical one. Brain and hand and heart



WRITING ROOM—FARMHOUSE OF MRS. W. M. RITTER, MANCHESTER, VT.  
Murphy & Dana, Architects.

what mathematics is to construction, or, to use the comparison favored by Mr. Ross, what the laws of rhythm, harmony and counterpoint are to music. Pure design is the theory; while the application of it lies in the particular art, the style, the conditions of time and people and locality, and, more specifically, in the conditions of the particular problem and

should work as one. The artists must feel as well as think, if his work is to be inspired.

Since design is not a cold, intellectual, mechanical process, Americans should be on their guard against being too self-conscious in their interest in abstract principles. The value of these lies rather in criticism and analysis and in teaching,



and they become useful in actual design only when they are as second nature to the designer. We should recall the example of France who has maintained her old art lore and traditions less impaired through the upheavals of the nineteenth century than any other nation. Her art is, therefore, more free

the best formulation of the principles of design that the world is seeking seems to be that of Mr. Denman Waldo Ross. It is contained in his book, "Theory of Pure Design."

Mr. Ross had fully worked it out in his lectures given in 1904, and subsequent revision has made no great changes



BEDROOM—FARMHOUSE OF MRS. W. M. RITTER, MANCHESTER, VT.  
Murphy & Dana, Architects.

and imaginative than ours; and, as Americans return to fundamentals, they should seek a like spontaneous expression. The next generation of Americans at the age of twenty will easily grasp what their fathers struggled to understand at forty, and will ask why there was ever such a pother made about it!

As I stated in a preceding paragraph,

in it. He has not attempted to apply his principles systematically to any one art except the art of painting, although his class teaching abounds in illustrations taken from the whole range of art. The value of his formulation is proven by the fact that other men have been willing to apply it in their own fields. The late Prof. H. Langford Warren

drew freely on Mr. Ross in his splendid critical teaching of architecture at Harvard. The result, in Warren's later teaching, was not essentially different from that of the great professors of the *École-des-Beaux-Arts*, except that, as

This volume is akin to a textbook; impersonal almost as a textbook on geometry, and, like a geometry, while easily understood, it leaves the reader to work out the practical applications for himself. Thus one cannot hope to master



DETAIL OF DINING ROOM—RESIDENCE OF MRS. ARTHUR CAHN, HARTSDALE, N. Y.  
Alfred Hopkins, Architect.

might be expected because of the greater strength of the background of art in France, the Paris teaching was the more imaginative and the more spontaneous.

All this lengthy statement of principles of design, and their place in the modern art world, will aid the reader in any study of writings on interior decoration. It is well to acquaint oneself with this background at its source, Ross' volume in *Pure Design*, referred to above.

all its aspects in a night's reading. Much study, constant observation, and, even better, practice in exercises in design are desirable. This is particularly true of principles of color. Principles and practice of color, in most arts, still offer the toughest problem for the designer. It was the sense of color, along with the sense of design, that became so atrophied in the nineteenth century.

When the significance of *Pure Design*





LIVING ROOM—RESIDENCE OF MRS. ARTHUR CAHN, HARTSDALE, N. Y.  
Alfred Hopkins, Architect.



DINING ROOM—RESIDENCE OF MRS. ARTHUR CAHN, HARTSDALE, N. Y.  
Alfred Hopkins, Architect.



LIVING ROOM MANTEL—DARRAGH PARK, ROSLYN, L. I.  
Peabody, Wilson & Brown, Architects.

is grasped, and its place in the modern movement to put art back into the arts, the next concern is how soundly the writers on interior decoration apply its principles in that particular art.

In reading the best recent American works on interior decoration, it would seem that the writers had succeeded admirably in applying the fundamental principles of art in the technique of interior decoration, but had not been so successful in their application in the matter of style and good taste. They are sound up to the point where they condemn period art in its strict historical interpretation, but they place too much emphasis on international and cosmopolitan influences. They do not consider national characteristics enough, and they overlook entirely the fundamental geographical factors in style—those of light, color, atmosphere and landscape, that were previously mentioned in these

pages. Here, clearly, is another source of confusion; here are another conflicting sets of principles to be reconciled.

Since the cosmopolitan influence brings into question the last great factor in style not hitherto considered, the whole matter of style may be set forth completely.

Style—which is much the same thing as good taste—is the background of art traditions of a people, the stream of experience that flows from the past, through the present, into the future. The character of this background is always changing, as its principles are being interpreted anew to fit existing conditions of place and time and problem. Some of these conditions change rapidly; others evolve slowly; while some of them never change. These factors may be classified as those of nature—geographical, climatic; as racial ones; as cosmopolitan and international; as social; as





LIVING ROOM—DARRAGH PARK, ROSLYN, L. I.  
Peabody, Wilson & Brown, Architects.

economic and mechanical; and as those of fashion. The geographical and climatic ones are geological causes; they are, therefore, eternal for man's purposes, and they will always exert a determining influence on the style of the art of a people. They vary in different regions of the earth's surface. Racial factors in style—national temperament—vary also by regions, and they vary slowly by time. That is to say, Americans will always be American in their art, not Englishmen or Frenchmen; but, as the American race grows older, or at certain times is more luxuriously inclined, and at others more austere, following changes in its social structure, it will slightly modify its style from century to century and from generation to generation. This racial factor is probably the one that produces periods in style. Style will also correspond to cosmopolitan influences from time to time; but, in any

soundly established art, the international influences will be quickly absorbed into the native stream, receiving a distinctive native stamp. As to the mechanical factors in style, some are nearly changeless, like the use of regional building materials; while others are not, such as the mechanical part of the house. Of the economic and social factors, some of these, too, change slowly or but little, by centuries and generations; while others vary in the space of a few years. Then, lastly, in this classification of factors of style and good taste come the evanescent ideas of fashion which vary from year to year.

Thus style consists of a multitude of factors: some permanent, others variable and varying differently each from the other. None of them can safely be ignored. The problem of the artist is the decision of exactly how to apply the theoretical principles of pure design in



BREAKFAST PORCH—DARRAGH PARK, ROSLYN, L. I.  
Peabody, Wilson & Brown, Architects.

any one art, in a specific case, in terms of style and good taste.

It seems evident that the factor of style, which I have called the cosmopolitan influence, is only one item in a complex series. It cannot be substituted for the whole, yet that nineteenth century practice of so doing still causes confusion today. Some American designers still follow it. How unsound this conception is may easily be realized by referring to the art history of France. The influence of the Renaissance, of the baroque, and later of the Chinese and classic art upon the French, has been carefully traced; but all critics agree that these influences were immediately absorbed, and the art of France always remained French. For instance, even at its height, the baroque was in France a French baroque, not Italian baroque.

Consequently, while American designers have the whole world to draw from, they will make a great mistake if they adopt internationalism as a fetish. In fact, American artists have been on a prolonged spree of cosmopolitanism,

and now they may well settle down to their own style traditions for a while, their minds limbered up with new ideas, and with the memory of a gay experience to stimulate their imagination on the path of progress.

Except for this exaggeration of the factor of internationalism in style, the best books on interior decoration are excellent indeed. Perhaps those of a more serious technical nature are Frank Alvah Parsons' "Interior Decoration, Its Principles and Practice," 1913; and Harold Donaldson Eberlein's "Practical Book of Interior Decoration," 1919. It is not my intention to review either of them here, beyond pointing out certain characteristics. The two books are somewhat parallel in plan, being roughly divided into two parts: one dealing with the application of the principles of pure design to the technique of interior decoration; the other covering a historical survey of the historic periods and of the international influences. Thus the two books supplement each other admirably. Mr. Parsons states general principles very clearly;



but in his historical survey his chapter on early American interiors is as superficial as it well could be, since it is largely based on the false conception that the early American interior was a somewhat crude formula of mahogany furniture contrasted against white walls. Mr. Eberlein's knowledge of American art is much sounder, for it is a field that he knows well. I prefer Mr. Parsons' summary of historical periods in essentials; but I like Mr. Eberlein's better in details. The latter has a better collection of illustrations, though here and there in them are to be noted the current faults of interior decoration, particularly that one of large, fat rectangles used beside delicate flowing curves and complex forms. However, from my own experience, I know how difficult it is to obtain good photographs of designs that illustrate specific principles, yet which in all other respects are faultless.

There are a dozen or more recent writings on interior decoration, besides scores of a more special character on furniture, textiles, ceramics, etc. The latter class can hardly be considered here, and only a few words may be spared for the former. Miss Edith Wharton's book was, with Miss Elsie de Wolfe's, "The House in Good Taste," 1913, a forerunner of the volumes of Mr. Eberlein and of Mr. Parsons. Each contains much sound wisdom, but neither attempts a technical discussion of principles. Of the other books, most of them are popular like the two just mentioned, but, unlike them, are too apt to be superficial. One notes in them the error of attempting to lay down specific rules and formulae as principles. The illustrations are often questionable, with designs that are sometimes crude examples of the mechanics of design, unclothed by any artistry. Thus they display that bad device of the modern decorator, the excessive use of groupings of minor objects in the shape of books, pictures, etc., around an axis. Except as part of a formal architectural motive, such as a mantelpiece, this practice is not design, but a substitute for it. It is the formula of the show window; though, to judge from some recent developments of that

art, it might be better to say, of the third rate show window. An exception to the rather mediocre character of many popular books on interior decoration is "The Effective Small House," by Lillian Green, which contains valuable suggestions on practical and economical methods of decorating the small house. The author is to be congratulated on the merit of her illustrations.

It remains to consider how these general works on interior decoration may be applied in terms of the small house. This is not a difficult matter. Economy rules out elaboration in most cases, and small dimensions forbid the use of the bulky furniture and decorations sometimes found in large houses. The type of design and factors of style also do not suit this kind of decoration. Almost automatically, therefore, the small house is limited to the small, compact, practical kinds of furniture of the eighteenth century, which were developed in France, England, and also in America. Of these, French types with their subtle curves in their pure form cannot be turned out successfully, except by the most artistic handworkers. Thus, for furniture that is practical and compact, and at the same time beautiful, the decorator of the small house can hardly do better than to work on the lines of the noted English designers of the late eighteenth century—Sheraton, Chippendale, Heppelwhite and the Brothers Adam; and also of the slightly earlier type of design, less exquisitely classic, but still finely proportioned and of much charm and picturesqueness, of homelike quality. These latter may also be better rendered by machinery than the more refined types, because of their simple rectangular shapes, turned legs or spindles, which require only a little hand finish, particularly, to soften the hard edges made by the machine.

One may only mention the great opportunity of house furnishings in the textiles, ceramics, metal work and art objects of all kinds. In addition to their own reviving household arts, Americans have the whole world to draw upon, and there is no reason why they should not borrow freely from the international influences of the day, in the modern love



DINING ROOM—RESIDENCE OF SAMUEL R. OUTERBRIDGE, CENTRE ISLAND, OYSTER BAY, N.Y.  
Electus D. Litchfield & Rogers, Architects.

of grace and vivacity and form, and of cheerful glowing color. But they should remember that they are Americans at the same time. Their plunder, even when gathered from all lands of the earth, should be wrought into a harmonious pattern of design in form and color and light, in the expression of American style and good taste, in the unity of a picture. The work of our best designers proves that this is their conception, whether consciously so or not, it does not matter. Indeed, if un-

consciously, it may be all the better art. To quote the concluding sentence of Mrs. Wharton's book, of her prophecy now being fulfilled by Mr. Ross: ". . . much that is empiric, much that is confused and extravagant, will give way before the application of principles based on common sense and regulated by the laws of harmony and proportion."

(This paper concludes Mr. Boyd's series, published in consecutive issues from November, 1919, to June, 1920.)



# The ARCHITECTURAL RECORD

October 1920



*Annual  
Country House  
Number*

*a Copy*

*Published in New York*

*\$3.00 a Year*



STUCCO AND PLASTER BASE

# BISHOPRIC

INSULATING SHEATHING

## GOOD —

that which possesses desirable qualities—promotes success—is *Servicable, Durable—Sound—Reliable* and *Economical*.

Thus Webster defined the word *Good*.

It is a small word with a big meaning—a word that when used with *Bishopric Stucco* and *Plaster Base* and *Sheathing* is not abused.

And from the first we ever made to the hundreds of millions of square feet that are in daily use, it has been “*Good*” and always will be.

*Bishopric Stucco* and *Plaster Base* and *Sheathing* dependability and Exclusive Patented features build for efficiency and economy, in fact “*Bishopric*” is in a class by itself.

### BISHOPRIC

**BISHOPRIC SHEATHING**—Strengthening, insulating, sound-deadening, weather-proofing unit; for exterior walls, sub-flooring and sub-roofing.

**BISHOPRIC STUCCO BASE**—Interlocking dovetailed key, insulating and waterproofing unit; creosote treated and not treated; for exterior.

**BISHOPRIC PLASTER BASE**—Interlocking dovetailed key, insulating, moisture proofing and sound-deadening unit; for interior plaster walls and ceilings.



The merits of *Bishopric Stucco* and *Plaster Base* and *Sheathing* are so well and favorably known that thousands of the foremost Architects in the World specify *Bishopric*.

We have prepared special technical working details for Architects and Builders—write for them.

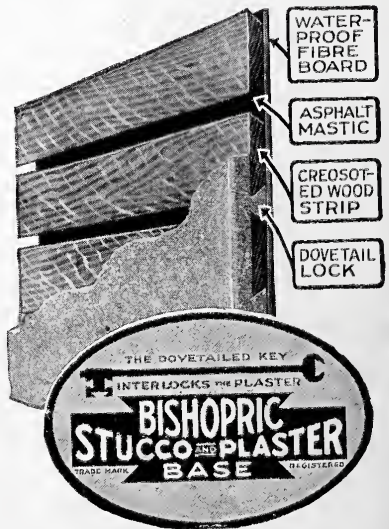

## THE BISHOPRIC MFG. CO.

102 ESTE AVENUE, CINCINNATI, OHIO

FACTORIES: CINCINNATI, OHIO, AND OTTAWA, CAN.



# THE ARCHITECTURAL RECORD



Vol. XLVIII. No. 4

OCTOBER, 1920

Serial No. 265

*Editor:* MICHAEL A. MIKKELSEN

*Contributing Editor:* HERBERT CROLY

*Business Manager:* J. A. OAKLEY

COVER—Water Color

PAGE

*By Jack Manley Rosé*

THE AMERICAN COUNTRY HOUSE

*By William Lawrence Bottomley, A.I.A.*

- |  |     |
|--|-----|
| I. FREEDOM AND RANGE OF DESIGN . . . .     | 260 |
| II. CONDITIONS AND TRADITIONS . . . .      | 273 |
| III. PROBLEMS OF BUILDING OF TODAY . . . . | 367 |

*Yearly Subscription: United States, \$3.00; Foreign, \$4.00; Single Copies, 35 cents. Copyright, 1920, by The Architectural Record Co. All rights reserved. Member Audit Bureau of Circulation.*

PUBLISHED MONTHLY BY

THE ARCHITECTURAL RECORD COMPANY

115-119 WEST FORTIETH STREET, NEW YORK

T. S. MORGAN, Pres.    W. D. HADSELL, Vice-Pres.    E. S. DODGE, Vice-Pres.    J. W. FRANK, Sec'y-Treas.



DINING ROOM—"CASA DRACAENA," RESI-  
DENCE AT SANTA BARBARA, CAL., OF  
GEORGE WASHINGTON SMITH, ARCHITECT.



# THE ARCHITECTURAL RECORD

VOLUME XLVIII



NUMBER IV

OCTOBER, 1920

## The American Country House

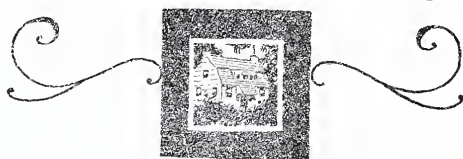

*By*

William Lawrence Bottomley

OUR architecture, like the population of the United States with its diversity of races, reflects types and styles from every land. Underlying all these differences, however, is a fundamental theory of plan based on convenience and comfort, which makes the American country house a thing unique.

It is a fact, whether to be regretted or not, that practically every style is represented. Besides the adaptations from our own Colonial, the English, French and Italian, one may find Japanese houses, Swiss chalets, Chinese pagodas, East In-

dian pavilions and even the hideous l'art nouveau of Austria and Germany. In many cases there is no justification or reason; in some cases, thanks to a particular setting, the result is a great success. Certainly the relationship of the house to its setting is becoming more understood by the public and the architects. Often the climate or an unusual site suggests some foreign treatment; but when an exotic style is chosen solely on account of some personal whim either by the owner or the architect, the result is apt to be artistic failure.



# Freedom *and* Range of Design



Our own Colonial style is justly considered one of the best that has ever been evolved, and within the last few years many books and publications in France and England have given it great attention and praise. As a style, however, it has been misused, and even now this type is being produced in great quantities in the Valley of the Mississippi, the Great Lakes Region and on the Pacific Coast—in many cases in an inappropriate way. Could anything be more incongruous than a white clapboarded New England farmhouse in Southern California? Charming when surrounded by green and overhung with great elms, it looks dry and frightened in the bold, broad and often bare landscape of the West.

We are free in our design. One might say too free at first thought, judging from the many experiments which have resulted in failure. On the other hand, one design of great success, striking out in new lines, more than compensates for a hundred failures. It has always been this way. The great masters of painting, sculpture and architecture are remembered by their successes, not by their failures.

Interest in experiments, shown by new departures in planning and in trying out new styles, is a sign of life in our architecture and has already evolved a certain type of house not found anywhere else in the world, which is more convenient than anything ever done before and often of great beauty.

When a thing has been well done a number of times and tried out over and over again in every possible way, it is easy to do it again, and the result with careful study is sure to be good. It is, however, apt to be dull, and with con-

stant repetition soon becomes stale and dry.

It is curious that this year only one superlatively good example of the American Colonial house has been found available for the Country House Number of the Architectural Record, that of Mr. Andrew V. Stout by John Russell Pope (page 353). The majority of things that could be had have strangely enough represented other styles than our own, showing, I think, that the desire for novelty and experiment so strongly marked in our national life is reflected in no uncertain way in our architecture.

When I first returned to this country about ten years ago, after studying abroad for several years, I was very much amused and rather disgusted by the remark of a charming and intelligent young woman, who said, "Oh, Mr. Bottomley, don't you just *love* period rooms?" The rage for a "Louis Quinze" drawing room was even then on the wane; but in many houses one would go through a series of rooms, the first English Tudor, the next so called Italian Renaissance, and the next some bastard French imitation. Very rarely were they well carried out. Happily this extreme has passed, and I think great credit should be given to the decorators in this country for their part in forming and improving the public taste. As a general thing American women know more and care more about their houses, the gardens and the interiors, than the men. The latter rarely take much interest in their homes or are willing to spare much time over them. Fortunately, I believe, there is a great increase in interest and sound knowledge and this may be particularly noticed among the younger men.



While there is still great diversity in style in our houses, two outstanding facts may be noted: the first, that the style chosen has relation to the setting—a tendency which is becoming increasingly evident; the second, that the styles are being handled with greater knowledge and skill, and are treated with more freedom. Free handling of style, instead of imitating some old example and often copying it badly, is a sign of life. The combination of different styles and different motives in a new way, so as to fuse into a consistent whole, is constructive design. Of all the houses here illustrated the house of Mr. Charles P. Blaney (page 288) at Saratoga, California, by Willis Polk, best illustrates this point. The detail is the purest and most beautiful classic, to large extent lost in the illustration. The plan is original, taking the courts and patios of the Spanish and early California styles and combining with their influence the practical necessities of a modern household. The roof lines are Italian or early Spanish, and the whole mass of the building is an original and picturesque

treatment of great beauty. The views from one court to another, the view of the house with its high tower and irregular roof lines and the charming gardens with great trees and extended views make a place of rare charm. It seems to me to represent something that we are driving for very definitely. (For additional plans and views see Architectural Record for February, 1918.)

“La Casa Dracaena” at Santa Barbara in a small house in number of rooms, and is placed in small grounds. It has the magical quality, however, of giving an impression of size and space, both inside and out, resulting from great simplicity and directness in both plan and design (page 263).

The landscape around the house is marvelous—on one side the mountains of Southern California with all their varied color, snow and green, sunshine and baking slopes, and on the other the flat country sloping westward to the sea and forming an admirable contrast to the steep slopes of the mountains. The house is placed right on the road in order to have



FARM GATE—RESIDENCE OF MRS. MARY E. STEWART, SANTA BARBARA, CAL.  
George Washington Smith, Architect.

every inch of land available for private gardens. This side of the house has no real windows, except the guest room. The other openings are merely slits for ventilation, but treated in a very interesting way by tiles built to form grilles. On the garden side, however, the house is very open. On the first floor the studio, drawing room and dining room open on the terrace, and even the small windows of the spiral Gothic staircase of stone, as one mounts to the second floor, afford delightful views: first, over the garden and, then, the distant view beyond. On the second story is a small loggia, between the two bedrooms.

Mr. Smith got his idea for the house from a thirteenth century Spanish house; but while the house has great style, it is not stylistic. The decoration is so simple that it might belong to any period. The plan of the garden is very early in its type and might well be a garden of the middle ages with its high surrounding walls and hedges and square parterres and beds, and simple straight paths and terraces. The gardens are closely related to the house by the terrace and walks, and a straight path leads directly from the windows of the living room out to a pool and thence across the gardens. The garden is practically an extension of the plan of the house and forms a great outdoor living space, as useful and as much used as are the interior rooms. It is interesting to notice the small amount of space given to halls and corridors, consisting only of a small vestibule and a circular staircase. The studio, a two-story room, extends from the road side to the garden side, giving it perfect privacy. To go from the living room to the dining room one passes along the terrace outside the house, a very delightful arrangement for California.

The planting about the house is unusual and delightful. The garden beds are bordered with low hedges enclosing the flowers and shrubs, while great trees form a fine background outside the garden. Along the side of the house on the road the planting is particularly interesting. Giant cactuses of many kinds make a fine silhouette against the plain walls of

the house, while small plants and pots relieve the balcony over the entrance door and give it a quaint charm.

The exterior of the house is as straightforward and direct as the plan. It is simple, even severe, in its lines, but extremely interesting in composition. Its great wall spaces and low tile roofs in different levels, its picturesque and informal massing give it an air as charming as it is unusual.

The tiles of the roof are made in the old way, a square slab of clay while wet being moulded over the thigh of the tile worker and then baked but not glazed. The soft red color is very varied and forms a fine contrast to the brilliant stucco of the walls. The window frames and sashes, painted a rich Gothic blue, are the only brilliant note of color on the exterior.

The interiors of the house are as interesting and delightful as is the exterior and have a distinctly old world flavor. The walls are treated in softly modelled plaster, and form a fine background to the old Spanish and Italian furniture; while the curtains of heavy monk's cloth harmonize admirably with the texture of the walls and the sturdy beams and woodwork of the ceilings. This simple scheme of backgrounds is carried throughout the house, and, with the brilliant velvets and brocades of the upholstery and hangings on the wall, give a restful but rich and livable look to all the rooms. Another point that should be particularly noted in the illustrations of the interiors is the dramatic lighting of the rooms, the contrasting strong shadows and bright lights caused by the small undraped windows. The materials of the house are of the simplest sort, but frankly used. One feels that here are the essentials of good design and color, all superfluous details eliminated and the effect strong, direct and beautiful. The design is so thoroughly successful on account of its contrasts in mass, in light and shade, and the interesting use of materials. There is no one touch of commercialism or insincere modernism in the entire place, inside or out.

I think that it may safely be said that





ENTRANCE SIDE—"CASA DRACAENA," RESIDENCE AT SANTA BARBARA, CAL., OF GEORGE WASHINGTON SMITH, ARCHITECT.



GARDEN FAÇADE, LOOKING TOWARD DINING ROOM—"CASA DRACAENA," RESIDENCE AT SANTA BARBARA, CAL., OF GEORGE WASHINGTON SMITH, ARCHITECT.

we are becoming much more frank in our use of materials than we were ten or twenty years ago. The English heritage of lath and plaster vaulting and false stone work, which came into vogue with Sir Christopher Wren after the Great Fire of London, developed a scandalous amount of fake design in this country. Paper wainscot to imitate wood, wall-papers to imitate brocades and leather, plaster composition slabs to imitate colored marble, shingle roof to imitate thatch, tin ceilings to imitate ornamental plaster, fooled no one and ruined our buildings and the public taste. All this fake and clap-trap is going out. It was not so long ago that Grant La Farge made his *bon mot*, in defining American architecture as "The art of making one material look like another material, which, if it were real, would be very objectionable." The best of our new work

shows that we are breaking away from this vicious habit. The simple houses are made of simple materials, so used that they are good looking in themselves. Beams and columns really support in a constructive way, instead of being false work set into the framing afterwards. The very fact that they are constructive parts gives them a decorative effect when properly spaced and arranged.

The setting of the American country house is usually less formal than that of the English and the Continental house. The fondness for flower gardens, such as one finds everywhere in England, is lacking, and it is only recently that we have begun to learn of the joys of living out of doors as is done in Italy and France. The question of labor is more difficult to solve here, and besides there has always been a prejudice against the grouping of farm buildings and vegetable





THE GARDEN FRONT—"CASA DRACAENA," RESIDENCE AT SANTA BARBARA, CAL., OF GEORGE WASHINGTON SMITH, ARCHITECT.



DRAWING ROOM—"CASA DRACAENA," RESIDENCE AT SANTA BARBARA, CAL., OF GEORGE WASHINGTON SMITH, ARCHITECT.



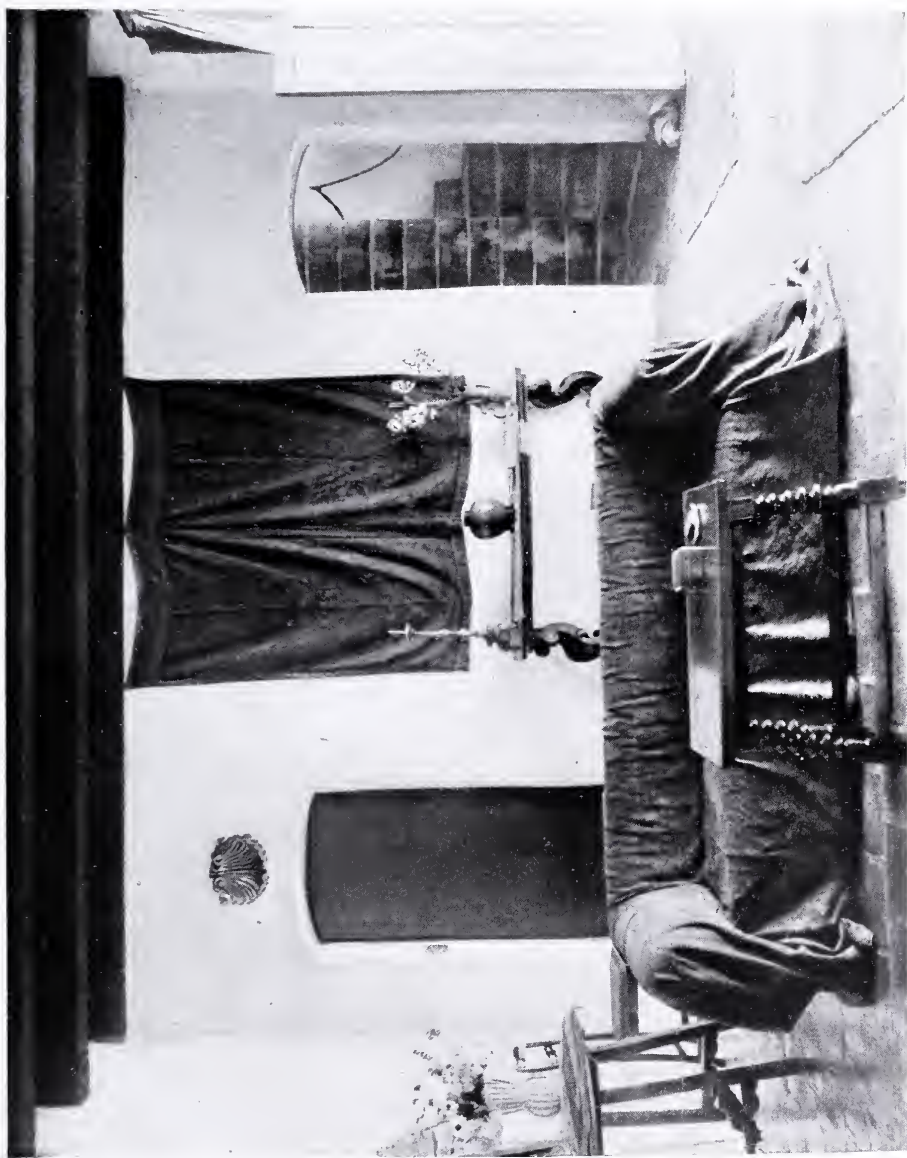

DRAWING ROOM—"CASA DRACAENA," RESIDENCE AT SANTA BARBARA, CAL., OF GEORGE WASHINGTON SMITH, ARCHITECT.



DRAWING ROOM—"CASA DRACAENA," RESI-  
DENCE AT SANTA BARBARA, CAL., OF  
GEORGE WASHINGTON SMITH, ARCHITECT.





STUDIO—"CASA DRACAENA," RESIDENCE  
AT SANTA BARBARA, CAL., OF GEORGE  
WASHINGTON SMITH, ARCHITECT.



BED ROOM—"CASA DRACAENA," RESI-  
DENCE AT SANTA BARBARA, CAL., OF  
GEORGE WASHINGTON SMITH, ARCHITECT.



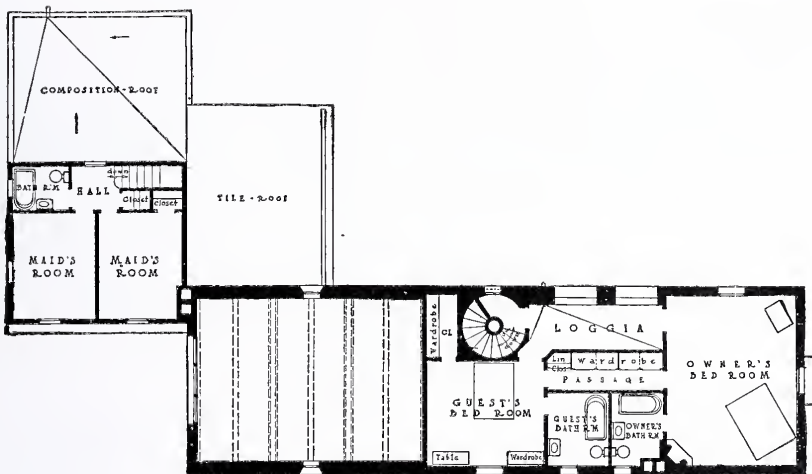

SECOND FLOOR PLAN

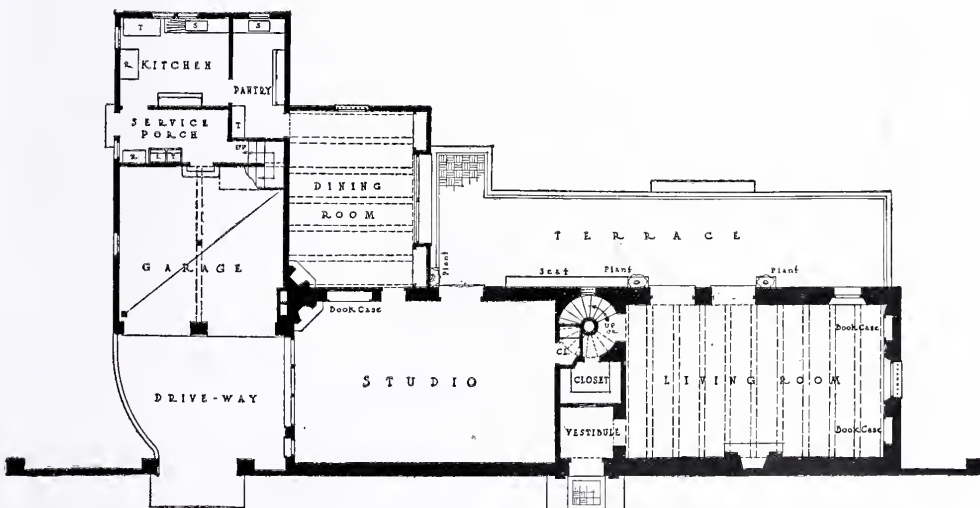

FIRST FLOOR PLAN

10 20 30 40 50 FT Scale

FLOOR PLANS—"CASA DRACAENA," RESIDENCE AT SANTA BARBARA, CAL., OF GEORGE WASHINGTON SMITH, ARCHITECT.

gardens in close relation to the house as is done so much abroad. Except in the Colonial period, when the formal English tradition made a strong impress on our early places, the naturalistic school of landscape gardening has until recently been almost universal. The Romantic movement, which started on the Continent at the end of the eighteenth century, swept over England, influencing the whole field of art, including architecture and landscape gardening, and reaching this country in the early years of the nineteenth century, turning the taste of the country toward informal landscape design, was based not so much on artificial picturesqueness as upon the preservation and development of the natural beauties. Within the last few years the formal garden, the terrace and paved walks adjoining the house and the strongly marked entrance driveway and forecourt have been introduced and extensively used. Fine recent examples of the forecourt may be seen in the illustrations of the house of Mr. Caspar W. Morris at Haverford, Pa., by Mellor, Meigs and Howe (page 295), and the house of Mr. Philip Sears at Brookline, Mass., by Bigelow and Wadsworth (page 317). Farm buildings are usually placed at some distance from the house and bear

no close relation to the design, as at the place of Mr. Guernsey Curran at Oyster Bay, L. I., by Guy Lowell (page 324). It is hard to understand why they have been so frequently placed near the houses abroad, as our plan of keeping the odors and flies of the farmyard and stable far removed from the houses seems greatly preferable if not quite so convenient. The vegetable garden, with its very necessary adjunct, the herb garden, and its planting of flowers for cutting, is a feature which we could well develop further, to give an added charm to our own country places.

One is glad to note a growing enthusiasm for out of door living and the use of shaded terraces, arbors and gardens, as actual living rooms for reading, for all meals of the day, for afternoon tea and for working.

There is an almost unlimited number of types of houses to draw from in presenting a survey of our recent country house work. This selection has been made from the point of view of new tendencies in design and the beauty of the finished work, taking into account the setting and planting. On account of the limited space available, it has been impossible to include many beautiful examples of a more conventional type.

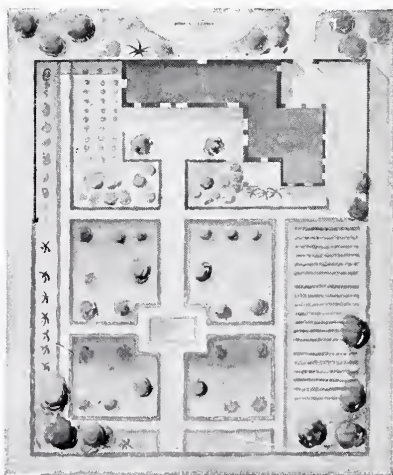

PLAN OF GARDEN—"CASA DRACAENA,"  
SANTA BARBARA, CAL.



# Conditions *and* Traditions

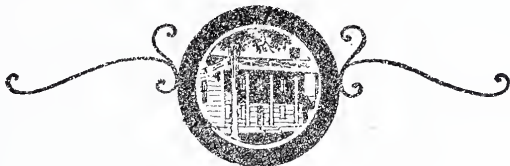

The house of Philip Goodwin at Woodbury, L. I., is French in style, and is interesting in composition and extremely handsome in its mass and detail. The conditions of grades, exposure and position of the main road passing the property presented an unusual problem. The site necessitated building the house on two levels on an "L" shaped plan, with the kitchen, service and kitchen courtyard, dining room and loggia on one floor, and the entrance hall, the living room, library, and principal bedroom on the floor above, on a level with the forecourt. The plan is very well balanced, and the façade facing the dining room terrace is perfectly symmetrical. On the entrance side, at the junction of the main body of the house and the service wing, is placed an octagonal tower, two stories in height, containing the stair hall, which gives an unusual and picturesque character to the court.

The plan of the house is as formal as it well could be, and yet it is essentially livable. The drop from one side of the big room, with the level court on the other side, the beautiful staircase leading down as well as up from the entrance hall, the loggia built under the house on the terrace side, and the effect of a balanced two-story house on one side, contrasting with a picturesque one-story house on the other side, yet all consistently treated and forming a perfect whole, give the house an unusual and interesting character.

The style of the exterior is a quite strict adaptation of the early French Renaissance. On the interior the rooms

are treated in a freer manner. The big room, although its furniture is old French, quite gives the effect of an Italian room, with no woodwork around the doors or windows, softly modelled plaster walls and richly painted beamed ceiling. The ceiling is made of solid, heavy constructive beams and girders, and is just the right scale for the height and proportions of the room. The design and arrangement of the furniture is extremely good.

The underlying principles of Italian design, its simplicity, directness and studied relationships of mass and wall surfaces contrasting with interesting openings, mark the work of Bigelow & Wadsworth on Mr. Philip Sears' place at Brookline, Mass. (page 323). The house is a large one, built amid rolling hills with a gentle slope on one side and a wide flat shaded terrace overlooking the valley on the other. It consists of several outside courts and terraces, upon which the various rooms give, and is a closely knit and well balanced plan.

In addition to the aesthetic side, the practical needs of living have been well taken care of, a rare and happy combination. The kitchens and service are conveniently arranged; the service court is placed at one side and hidden; the entrance drive goes to the entrance door and stops there, and the rest of the place is developed into secluded gardens and informal lawns.

From the gateway of the forecourt one gets a view of the fine Georgian façade and the beautiful wall which partially

HOUSE AT WOODBURY L.I.  
MAIN FLOOR PLAN

GOODWIN BULLARD & WOOLSEY  
ARCHITECTS  
4 EAST 39 ST. N.Y.C.

SCALE IN FEET

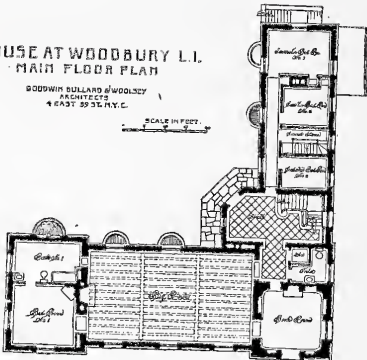

HOUSE AT WOODBURY L.I.  
GROUND FLOOR PLAN

GOODWIN BULLARD & WOOLSEY  
ARCHITECTS  
4 EAST 39 ST. N.Y.C.

SCALE IN FEET

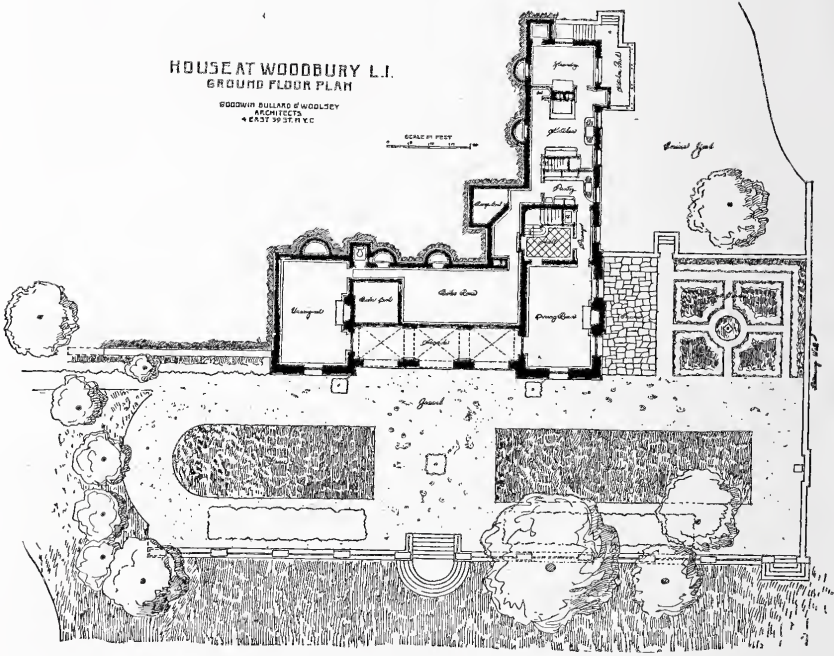

RESIDENCE AT WOODBURY, L. I., OF  
PHILIP L. GOODWIN, OF GOODWIN,  
BULLARD & WOOLSEY, ARCHITECTS.





RESIDENCE AT WOODBURY, L. I., OF PHILIP L. GOODWIN,  
OF GOODWIN, BULLARD & WOOLSEY, ARCHITECTS.



Country Life Photograph

RESIDENCE AT WOODBURY, L. I., OF  
PHILIP L. GOODWIN, OF GOODWIN,  
BULLARD & WOOLSEY, ARCHITECTS.





Country Life Photograph.

RESIDENCE AT WOODBURY, L. I., OF  
PHILIP L. GOODWIN, OF GOODWIN,  
BULLARD & WOOLSEY, ARCHITECTS.





RESIDENCE AT WOODBURY, L. I., OF  
PHILIP L. GOODWIN, OF GOODWIN,  
BULLARD & WOOLSEY, ARCHITECTS.





RESIDENCE AT WOODBURY, L. I., OF  
PHILIP L. GOODWIN, OF GOODWIN,  
BULLARD & WOOLSEY, ARCHITECTS.



Country Life Photograph.

RESIDENCE AT WOODBURY, L. I., OF  
PHILIP L. GOODWIN, OF GOODWIN,  
BULLARD & WOOLSEY, ARCHITECTS.





Country Life Photograph.

RESIDENCE AT WOODBURY, L. I., OF  
PHILIP L. GOODWIN, OF GOODWIN,  
BULLARD & WOOLSEY, ARCHITECTS.



RESIDENCE AT WOODBURY, L. I., OF  
PHILIP L. GOODWIN, OF GOODWIN  
BULLARD & WOOLSEY, ARCHITECTS.





Country Life Photograph.

RESIDENCE AT WOODBURY, L. I., OF  
PHILIP L. GOODWIN, OF GOODWIN,  
BULLARD & WOOLSEY, ARCHITECTS.



RESIDENCE AT WOODBURY, L. I., OF  
PHILIP L. GOODWIN, OF GOODWIN,  
BULLARD & WOOLSEY, ARCHITECTS.





Country Life Photograph.

RESIDENCE AT WOODBURY, L. I., OF  
PHILIP L. GOODWIN, OF GOODWIN,  
BULLARD & WOOLSEY, ARCHITECTS.



TOWER OF BLANEY RESIDENCE,  
SARATOGA, CAL.

screens the service wing, culminating in the high entrance pavilion.

The entrance hall is a most unusual and beautiful room. The ceiling is of dark wood finished with a satiny, ancient texture, and rests on simple walls and columns of fine proportion and finish. The plaster-walls have a most interesting texture and color, the finish of the plaster looking like paint that has been put on with a palette knife by a master, and varying in color through greys almost to a yellow, which gives a warmth and glow to the walls almost like old silver gilt. The effect of the whole room is one of great simplicity and great beauty. All the parts are well arranged. The sweep of the stairway is just right for the ceiling height; the doors are well shaped and well placed. In reality it is even finer than the illustration. It is a rare example of that subtle quality so much discussed and so little understood—proportion.

The dining room, the drawing room and the library are all paneled, and the treatment of bookcases set into the wood

walls flanking the door in the latter room is particularly worthy of notice.

The first impression of the Blaney residence at Saratoga, Cal., by Willis Polk & Company, is one of accidental charm, of unstudied beauty, and it is not until after the entire group is understood that one begins to find that it is in reality a very well calculated piece of art.

On a steep hillside the house rises in a picturesque mass dominated by a fine tower (page 286); while on the other side the open loggia, which serves as a living porch, is extended by open arcades and passages to a courtyard half screened by double arched windows, through which one catches a glimpse of an outside staircase leading to a terrace above, and behind which rises one of the higher pavilions. The house is surrounded on this side by magnificent spreading trees which reflect themselves in a fountain and pool, and between whose trunks one looks through to a blue distance of the landscape. This loggia is a most beautifully studied piece of classical architecture. The proportions of the columns and the finely drawn entablature supporting the roof above contrast vividly with the simpler masses of adjoining walls and plain, arched windows. The entire place, with its gardens and outbuildings,



DETAIL OF GATEWAY TO BLANEY  
ESTATE, SARATOGA, CAL.



is imbued with a poetry that is as subtle as it is rare.

The selection of the style, with its fundamental Spanish and early Californian basis blended with the Italian classic, is quite perfect for the Californian climate and landscape. The wide, overhanging eaves where shade is wanted, the close cropped roofs where a strong, boldly modeled mass is needed, and above all the wide, plain stucco wall surfaces form a perfect combination with the heavy, gnarled trunks and branches of the live oak and banyan trees. The play of light and shade, of sunlight and leaf shadows on the walls and ground, the reflections and deep shadows of the architecture itself, make the most of the lighting effects of a wonderful climate.

Particular attention should be given to the design and placing of the entrance gates, and to the relation of the walls and posts to the planting. The wide farm gate, on page 287, with the great overhanging trees, looks as if it had stood there for centuries, so carefully has it been studied with regard to these trees.

The house of Mr. Walter Flory at Cleveland, Ohio (page 290), by Howell & Thomas, shows a clever handling of a house built in the city, but with all the



PAVILION ON BLANEY ESTATE, SARATOGA, CAL.

characteristics and advantages of a country house. Fortunately for the owners and for the architects, the grounds contained a great number of fine trees, chiefly elms, maples and oaks.

The style of the house is modified English. The mouldings are of both stone and wood, and range in their profiles from the Gothic to the Colonial. The masses of the house are bold and interesting, and the long, low lines of the front terrace and entrance side give an impression of quiet and repose.

Here again we find that the plan is typically American and well arranged. The book room, hall, living room and porch take up one side of the first floor, while behind comes the dining room, with a convenient kitchen wing. The garage is connected to the house and forms a part of the composition, but the entrance to it is outside under a covered walk.

The stonework of the first story and the chimneys is of a very lovely local stone, laid with great care; and while it is an irregular bond, the grouping and placing of the stones have been particularly well handled. The stucco of the second story, warm in tone, combines well with the stonework and contrasts with the grey of the roof.

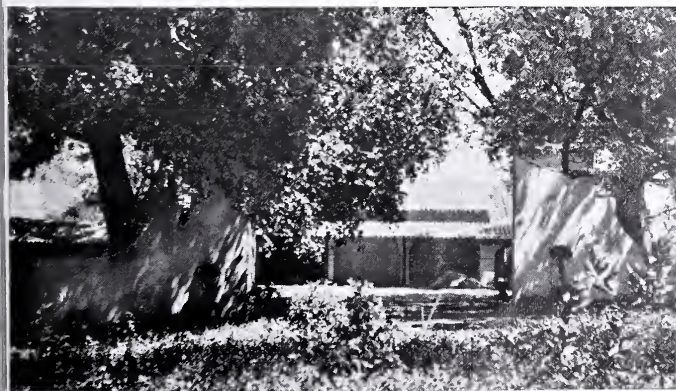

FARM GATE ON BLANEY ESTATE, SARATOGA, CAL.



LOGGIA—CHARLES D. BLANEY ESTATE, SARA-  
TOGA, CAL. WILLIS POLK & CO., ARCHITECTS.



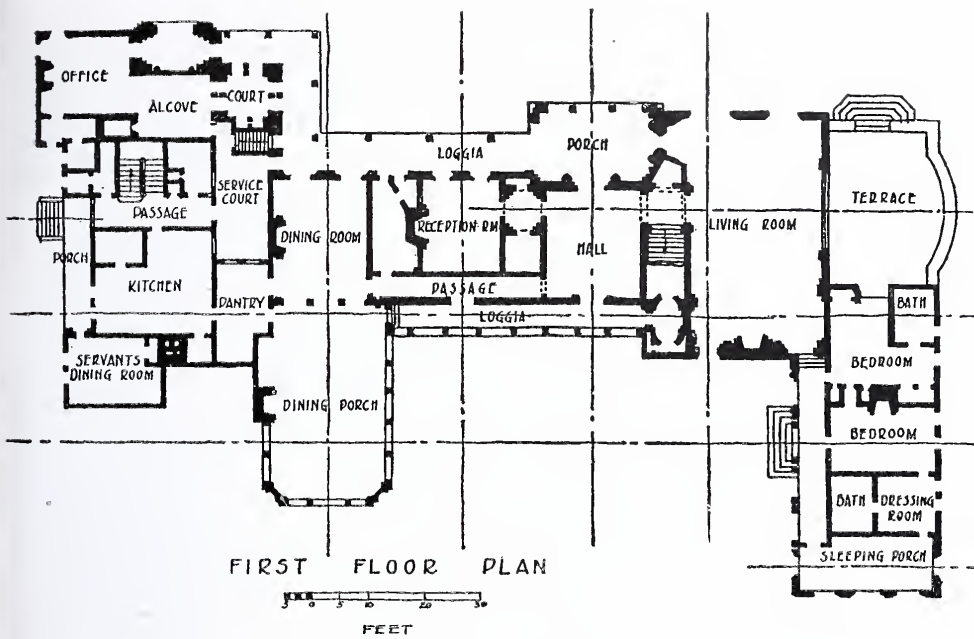

FIRST FLOOR—RESIDENCE OF CHARLES D. BLANEY ESTATE, SARATOGA, CAL.  
 Willis Polk & Co., Architects.

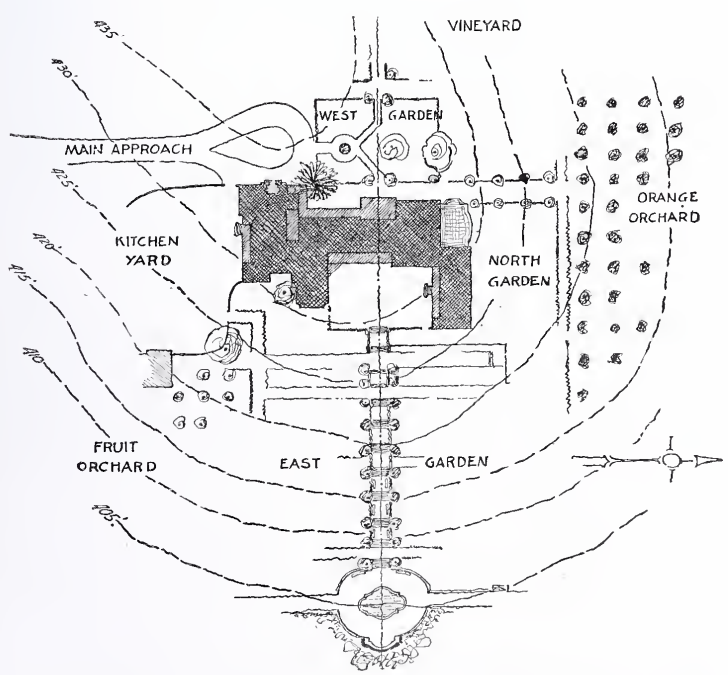

GROUND PLAN OF CHARLES D. BLANEY ESTATE, SARATOGA, CAL.  
 Willis Polk & Co., Architects.

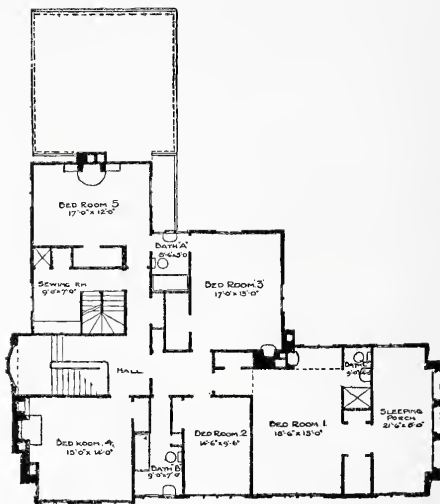

SECOND FLOOR PLAN

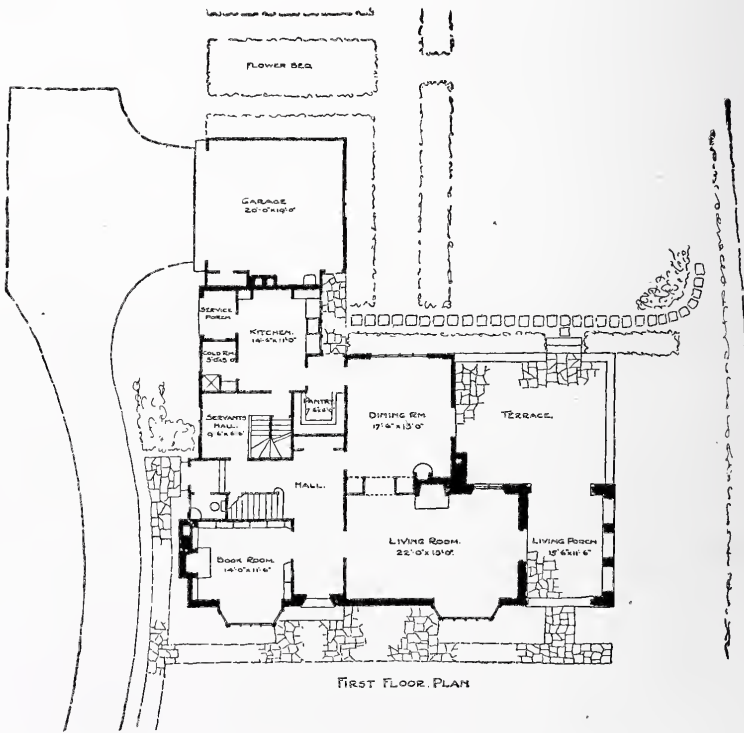

FIRST FLOOR PLAN

RESIDENCE OF WALTER FLORY, ESQ., CLEVELAND, O. HOWELL & THOMAS, ARCHITECTS.



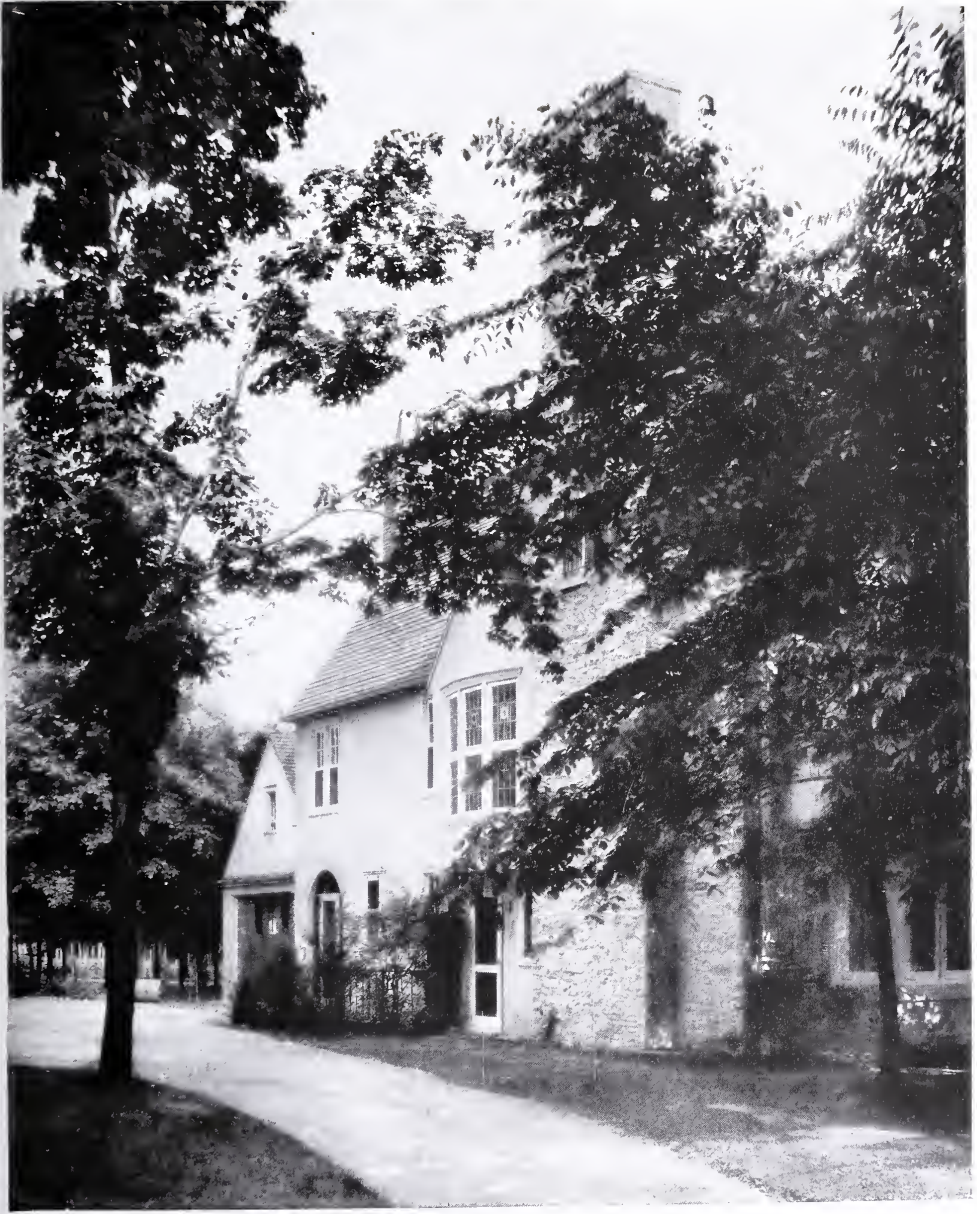

RESIDENCE OF WALTER FLORY, ESQ., CLEVELAND, O. HOWELL & THOMAS, ARCHITECTS.



RESIDENCE OF WALTER FLORY, ESQ., CLEVELAND, O. HOWELL & THOMAS, ARCHITECTS.





RESIDENCE OF WALTER FLORY, ESQ., CLEVELAND, O. HOWELL & THOMAS, ARCHITECTS.



RESIDENCE OF WALTER FLORY, ESQ., CLEVELAND, O.  
Howell & Thomas, Architects.



RESIDENCE OF WALTER FLORY, ESQ., CLEVELAND, O.  
Howell & Thomas, Architects.



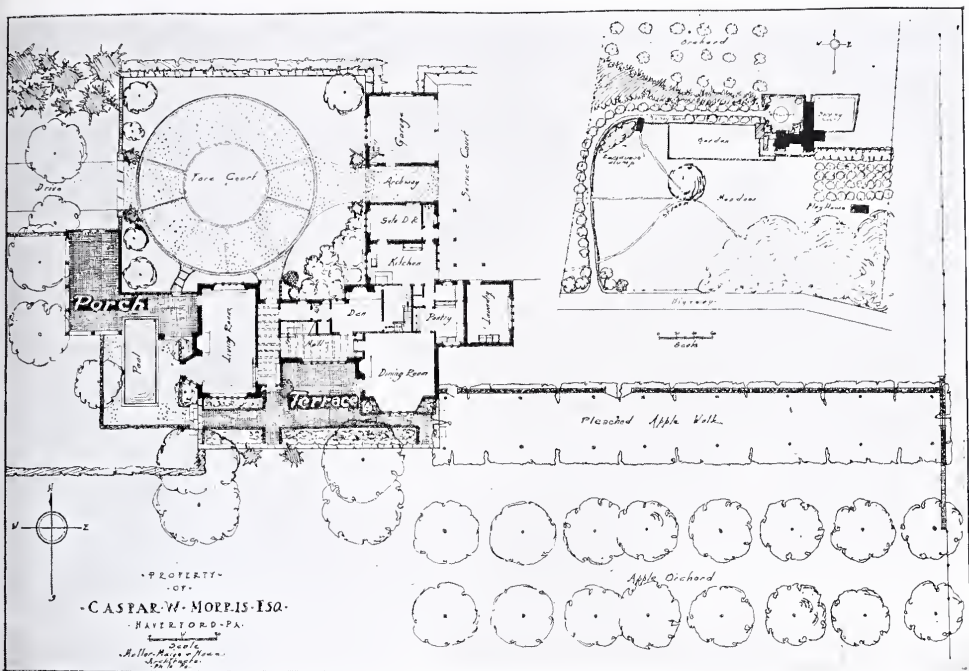

On the interior, the entrance hall, as one enters the house, is finished in rough east plaster and shows the strong present-day tendency toward elimination of all woodwork around the doors and windows. The backgrounds of all the rooms are treated quietly, and one feels conscious in the house of the beautiful trees and grounds that surround it. From the dining room a path bordered with flowers leads off between the trees from the wide glass doors to a circular pool brimming level with the grass and surrounded by a lawn and the great trees.

Certainly one distinct tendency in our garden and landscape planning is the careful arrangement of drives, courts, terraces, gardens and walks around the house to assure privacy and pleasant places to live outside the house and to provide a fine foreground for the distant views. One of the best studied and most successful houses that I have seen in this country is that of Mr. Caspar W. Morris at Haverford, Pa. It is a perfect English type, with a certain suggestion of the old French Gothic house adapted to conform to all our complex modern re-

quirements. The exposure of the house is so arranged that the principal rooms all face south, with the dining room getting the morning sun in its bay window, the living room porch placed on the southwest corner and open on three sides to catch every breeze. The entrance drive, curving in from the road at some distance from the house, enters the forecourt on the north side after passing through a straight avenue planted with rows of trees on both sides. Beyond the forecourt to the east is a service court, with garage, kitchen delivery and drying ground shut off from the forecourt by a long service wing of the house, under which is the archway connecting the two courts.

A long, narrow, flagged terrace bordered with luxuriant planting extends the length of the house on the south side and connects the intimate walled garden of the living room porch with a long pleached walk of apple trees. This is the kind of garden planning which makes for joy of living. Beyond the terrace is a meadow with great trees and a stream, and while it is near the road it is as se-



FORECOURT, THROUGH ARCHWAY—RESIDENCE  
OF CASPAR W. MORRIS, ESQ., HAVERFORD, PA.  
MELLOR, MEIGS & HOWE, ARCHITECTS.





ENTRANCE FROM FORECOURT—RESIDENCE  
OF CASPAR W. MORRIS, ESQ., HAVERFORD,  
PA. MELLOR, MEIGS & HOWE, ARCHITECTS.



THE POOL, FROM THE PORCH—RESIDENCE  
OF CASPAR W. MORRIS, ESQ., HAVERFORD, PA.  
MELLOR, MEIGS & HOWE, ARCHITECTS.





THE POOL AND THE SLEEPING PORCH—RESIDENCE OF CASPAR W. MORRIS, ESQ., HAVERFORD, PA. MELLOR, MEIGS & HOWE, ARCHITECTS.





SOUTH FAÇADE—RESIDENCE OF CASPAR  
W. MORRIS, ESQ., HAVERFORD, PA.  
MELLOR, MEIGS & HOWE, ARCHITECTS.





SOUTH ENTRANCE—RESIDENCE OF CAS-  
PAR W. MORRIS, ESQ., HAVERFORD, PA.  
MELLOR, MEIGS & HOWE, ARCHITECTS.



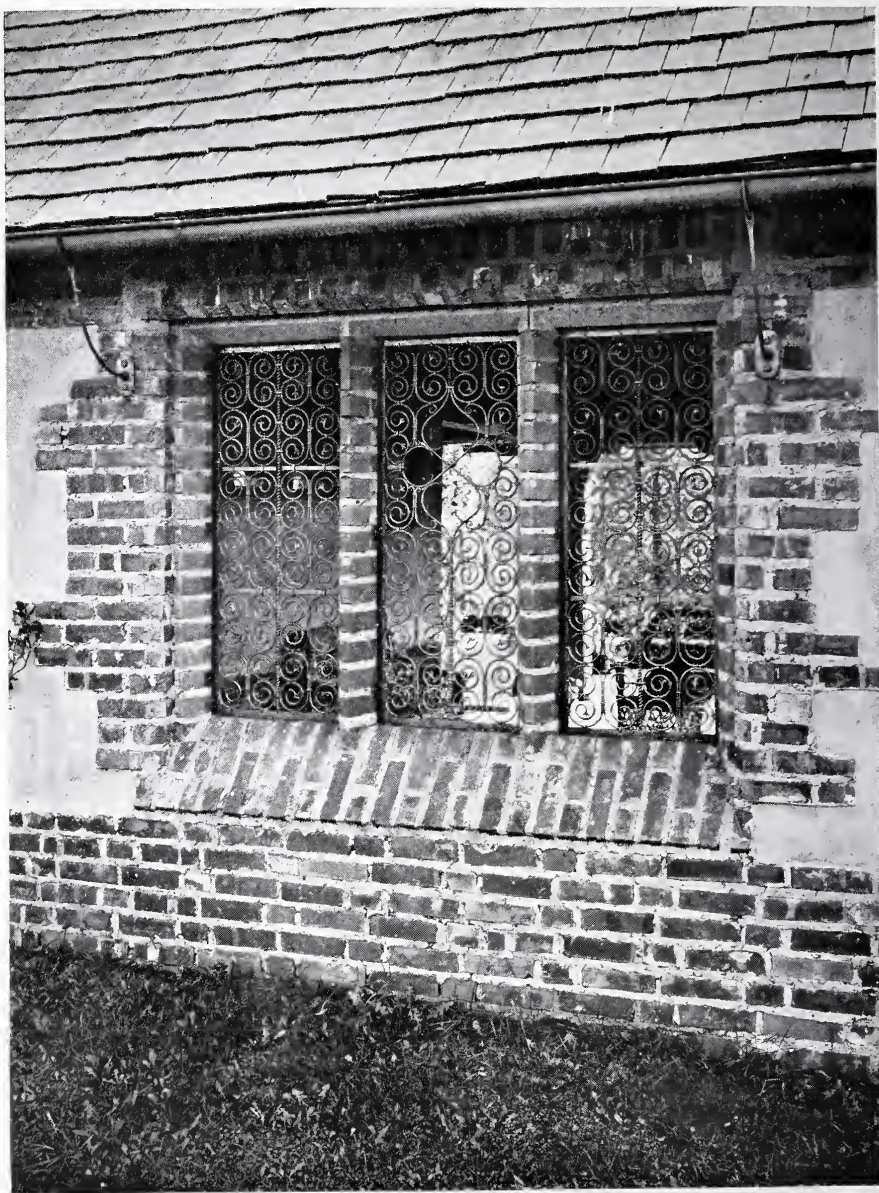

IRON GRILLE ON PORCH—RESIDENCE OF  
CASPAR W. MORRIS, ESQ., HAVERFORD, PA.  
MELLOR, MEIGS & HOWE, ARCHITECTS.



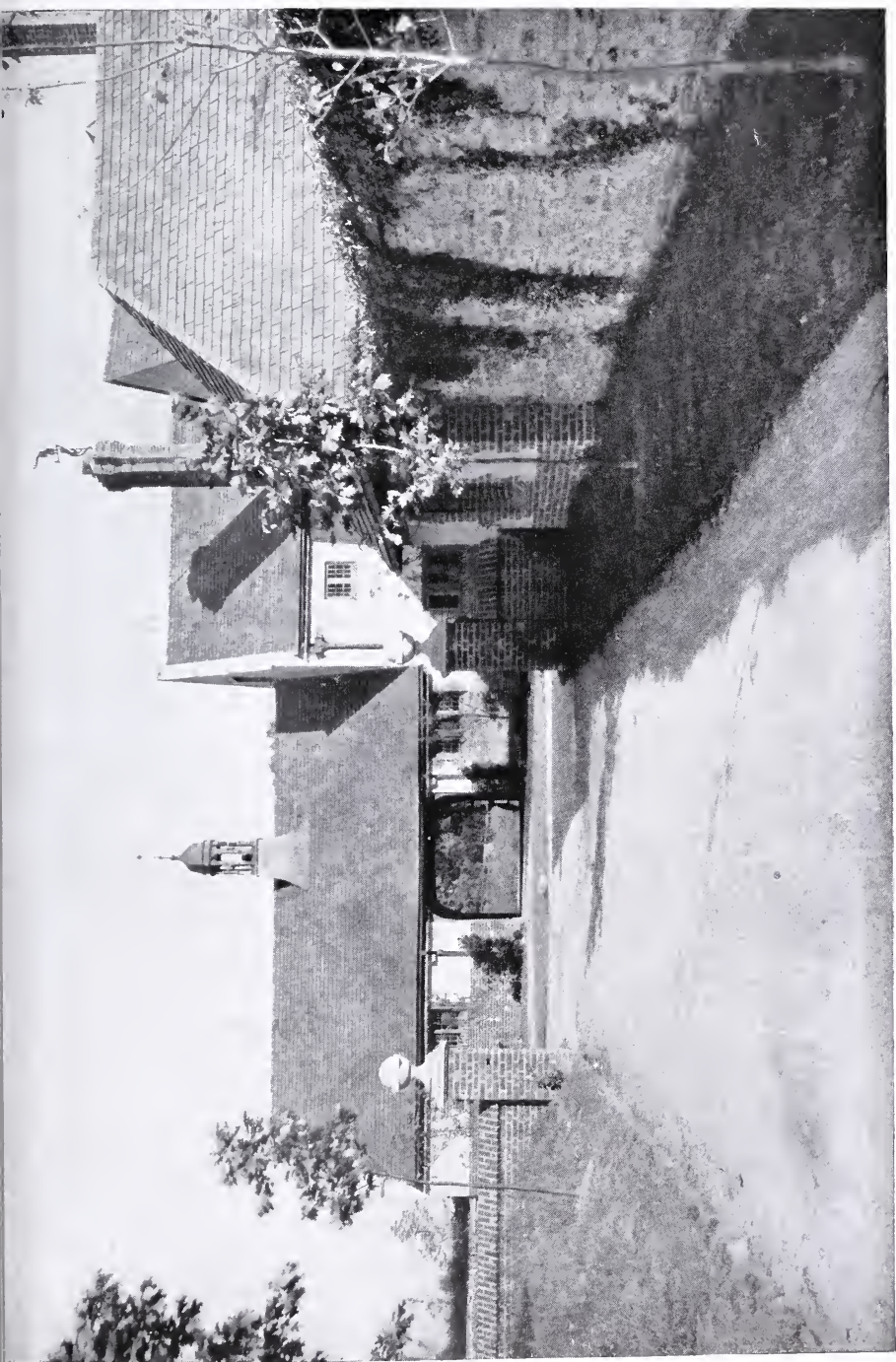

THE SERVICES, FROM THE DRIVE—RESIDENCE  
OF CASPAR W. MORRIS, ESQ., HAVERFORD, PA.  
MELLOR, MEIGS & HOWE, ARCHITECTS.



HALLWAY—RESIDENCE OF CASPAR  
W. MORRIS, ESQ., HAVERFORD, PA.  
MELLOR, MEIGS & HOWE, ARCHITECTS.





ENTRANCE HALL—RESIDENCE OF CAS-  
PAR W. MORRIS, ESQ., HAVERFORD, PA.  
MELLOR, MEIGS & HOWE, ARCHITECTS.



SECOND STORY HALLWAY—RESIDENCE OF  
CASPAR W. MORRIS, ESQ., HAVERFORD, PA.  
MILLOR, MEIGS & HOWE, ARCHITECTS.



cluded as if it were miles from the nearest house, an ideal arrangement for both winter and summer.

The composition of the house, with its many breaks in plan and irregular roofs crowned by high chimney stacks, is interesting; and, furthermore, the detail of the different parts and the way the materials are used are extremely good. The heavy beams used in the construction for posts and lintels and in the half timber work, heavily adzed, perhaps a shade too heavily, and the pegging of the different beams as seen in the gable ends, particularly, give a very decorative effect. Brick is used for the chimneys and for the window and door jambs, giving a warmth of color to the house. The windows are leaded casements, set in steel frames, which give so much lightness and character to the whole building.

Particular note should be made of the stone wall bordering the entrance drive, shown on page 303. The rough ledge stone has been laid with wide joints of mortar and pointed flush in the Pennsylvania manner, but seldom does one see a wall so successful in its texture.

It is the wealth of imagination which is shown throughout the design, the combination of many different elements into a consistent whole, the unexpected little garden with its pool beside the living room porch, that make the house so particularly charming. Nothing seems to have been neglected—covered sheltered places beside the terrace to sit in on a blowy day, the gracious half round steps leading down from the terrace to the meadow—everything lends to the effect of repose, comfort and good looks; it takes but little imagination to think how much finer it will be even than it is now, when, in a few years, the small trees just planted are matured.

The interiors of the house are treated for the most part with wood beamed ceilings and plastered walls of an antique texture, and again the elimination of woodwork around the doors and windows should be noted. The floor boards are wide and polished. The slanting, half octagonal ceiling of the second story hall, following on one side the slope of the

low pitched roof, the lines again recalled by the pointed arched doorway at the end, makes a quaint and unusual treatment. One cannot help thinking how some old English furniture and tapestries and a few decorative pictures and maps would make the interiors sing.

Another kind of American country house is the formal distinguished classic type. The plan is not only balanced, but symmetrical. This is well represented by the house of Mr. William H. Clarke, at Stockbridge, the "Villa Virginia" (page 309), by Messrs. Hiss & Weekes, and also by Mr. Guernsey Curran's house at Oyster Bay (page 324), by Mr. Guy Lowell, and the house of Mr. Philip Sears, by Messrs. Bigelow & Wadsworth, at Brookline, Mass. (page 317).

The "Villa Virginia" is distinctly Italian in style and is very well handled. The plan is simple and direct, and clearly expresses the main parts of the interior. The central mass contains a hall and staircase hall and minor service functions on the entrance side facing east and the three great rooms: the dining room, the living room and the library. On the south side the vaulted loggia, open on all four sides, balances the kitchen wing, which is cleverly arranged so that the court side is taken up with stairs and closets, making the windows of the kitchen and other rooms open on the service court to the north.

The mass and proportions of the house are good; the two flanking wings are one-story high, with flat roofs enclosed by a pedestal course which carries around the main building. This portion is a full two stories in height, and on the court side, by a clever lifting of the roof, a frieze with windows is introduced, giving an added effect of dignity to the entrance façade. The use of materials does not compare with the high Italian Renaissance. The stucco work, for instance, while not exactly harsh looking, is rather too smooth, and the roof tile has a monotonous, mechanical quality.

The problem of getting a good texture to stucco work is a most difficult one with our too excellently trained workmen, whose chief idea usually is to get a per-

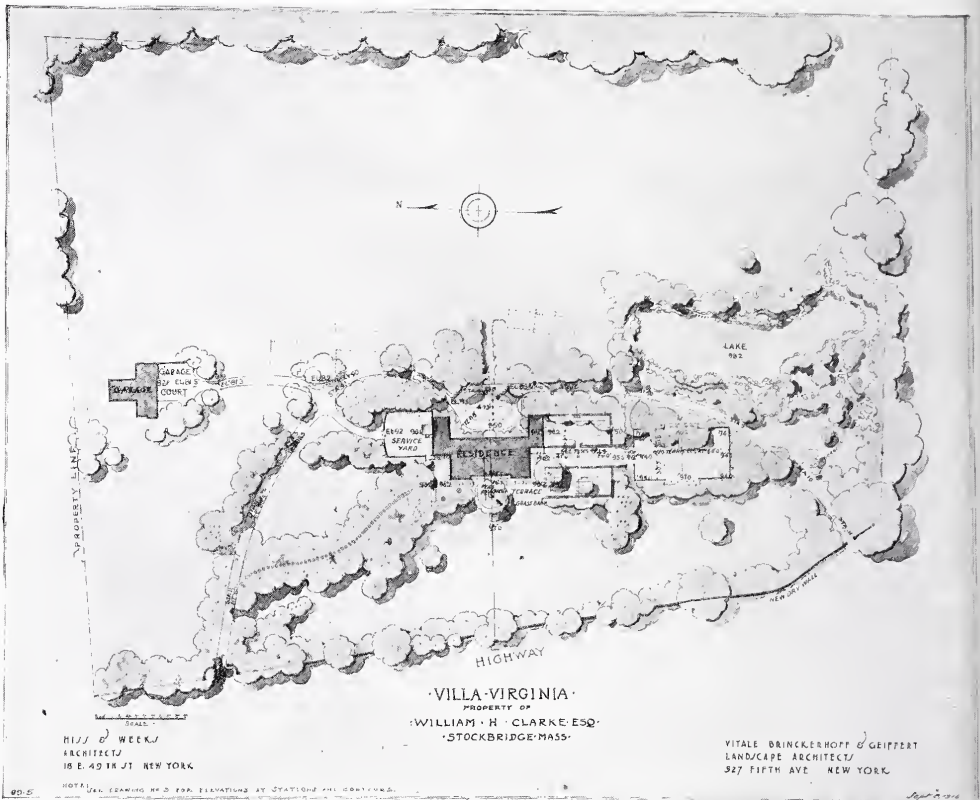

fectly straight surface. A very small trowel to smooth the surface after the stucco is put on, and for interior plastering the same technique, followed up by a small wet sponge, give a modelling and texture to a flat wall that makes it far more interesting. The small trowel makes it impossible for the man to get it smooth, and straightedges and floats should be quite taboo. In this way the surface will look straight enough, but will have a slight waviness, giving color and life to the wall, such as one always finds in the work of the Italian Renaissance before the middle of the eighteenth century.

The garden design by Vitale, Brinkerhoff and Geiffert belongs to the Romantic English or American school, with its winding drives, curving paths and open naturalistic lawns. The trees surrounding the house are really magnificent, and the additional planting of cedars and low junipers goes well with the character of the house.

The entrance hall and anteroom are vaulted, with a restrained treatment of mouldings and panels that make an interesting contrast with the black and white marble tile floors and form an excellent background for the furniture, pictures and rich hangings. The dining room, the living room and the library have richly coffered and beamed and painted ceilings, which recall the color of the furniture, rugs and hangings and give a fine decorative effect to the rooms.

A third house, belonging to an architect and designed for himself, is that of Mr. Goodhue at Montecito, California (page 313). "La Cabaña" is an old adobe house that Mr. Goodhue found and added on to and rearranged for himself. It is tiny, but just big enough, thoroughly attractive and very comfortably arranged.

The "Close," the home of Mr. Henry B. Binnse at Short Hills (page 346), was designed by Mr. Baillie Scott, an English architect, and is English in appearance.



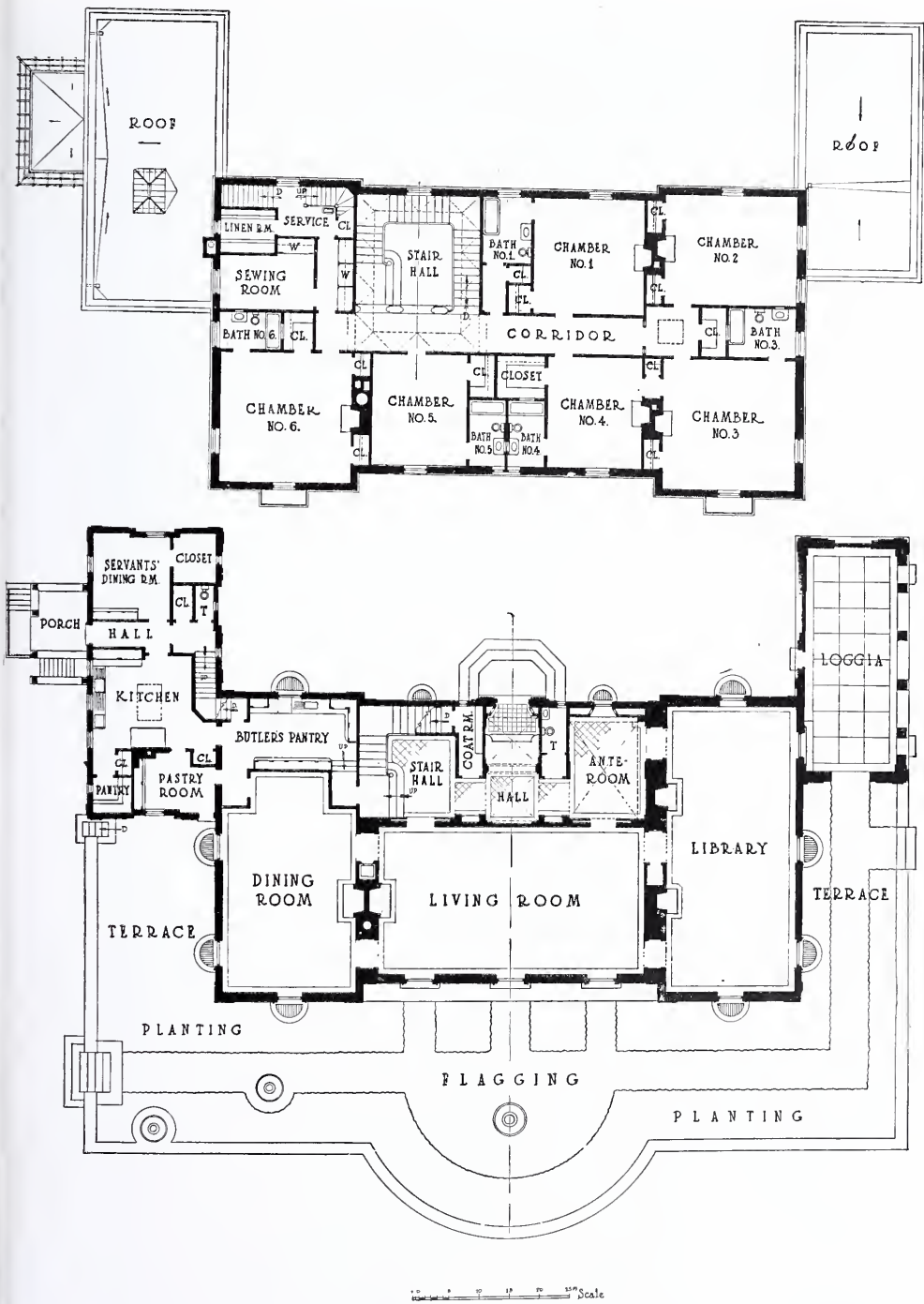

FIRST AND SECOND FLOOR PLANS—"VILLA VIRGINIA," RESIDENCE OF WILLIAM H. CLARKE, ESQ., STOCKBRIDGE, MASS. HISS & WEEKES, ARCHITECTS.



FACADES OF THE SIDE AND FACING THE GARDEN—  
"VILLA VIRGINIA," RESIDENCE OF WILLIAM H. CLARKE,  
ESQ., STOCKBRIDGE, MASS. HISS & WEEKES, ARCHITECTS.





THE FORECOURT—"VILLA VIRGINIA," RESIDENCE OF WILLIAM H. CLARKE, ESQ., STOCKBRIDGE, MASS., HISS & WEEKES, ARCHITECTS.





DINING ROOM—"VILLA VIRGINIA," RESIDENCE OF WILLIAM H. CLARKE, ESQ.,  
STOCKBRIDGE, MASS.  
Hiss & Weekes, Architects.



ANTEROOM—"VILLA VIRGINIA," RESIDENCE OF WILLIAM H. CLARKE, ESQ.,  
STOCKBRIDGE, MASS.  
Hiss & Weekes, Architects.





THE PORCH AND SECOND STORY AZOTEA BEYOND—  
"LA CABASA," RESIDENCE AT MONTECITO, CAL.,  
OF BERTRAM GROSVENOR GOODHUE, ARCHITECT.



THE KITCHEN WING AND THE AZOTEA—"LA CABANA," RESIDENCE AT MONTECITO, CAL., OF BERTRAM GROSVENOR GOODHUE, ARCHITECT.



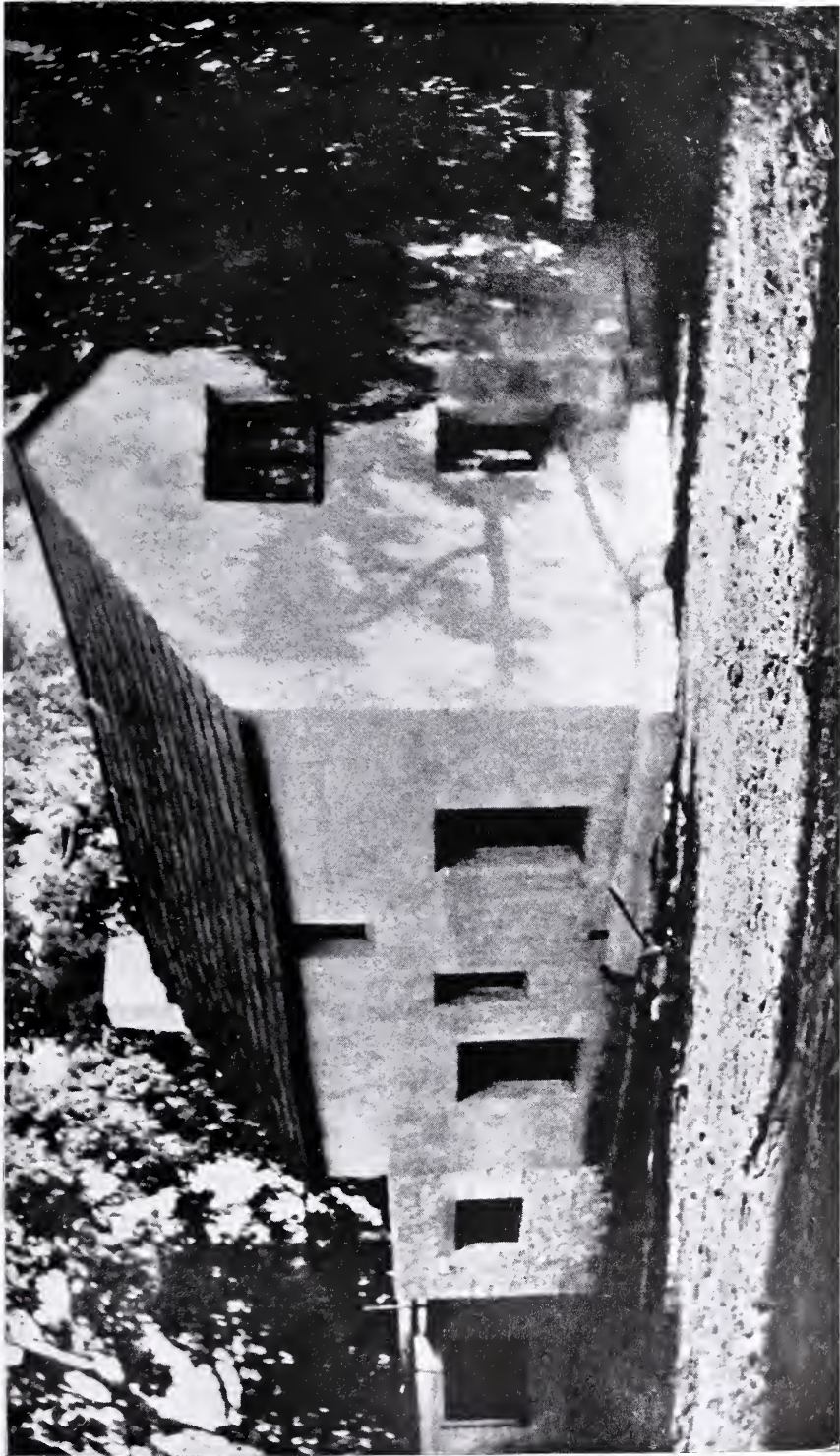

THE LIVING ROOM WING—"LA CABANA,"  
RESIDENCE AT MONTECITO, CAL., OF BER-  
TRAM GROSVENOR GOODHUE, ARCHITECT.

and plan. It is very interesting to contrast this house with the other more American types that are illustrated in this article. "The "Close" is very charming. Surrounded by old trees, its half timber work overhung with wistaria and roses, it has much of the homelike substantial quality that we associate with the English country house. There is a luxuriance about its shrubs and vines that reminds one of England; a solid, honest quality in its construction and design that recall its prototypes on the other side of the Atlantic. Most interesting of all are the English characteristics of its plan. It is built around three sides of a court, and the central feature is the living room with the main entrance door opening into it—a survival of the old Tudor days, when the great hall was the heart of the dwelling. The wings contain a great number of different and to a large extent unrelated divisions, such as the chicken house and run, the garage, woodshed and workshop, as well as the kitchen, meat house and rabbit house, thus bringing under one

roof the various outbuildings of an American layout. There is perhaps less convenience than in one of our typical plans.

The beams which show in the half timber of the exterior are fine heavy pieces of timber, not the thin strips that are so often seen in this country; they are well adzed, and pegged together with round wooden pins. The pins add to the decorative effect, and are also a very lasting and practical method of joining the beams together.

The residence of Mr. Willard P. Lindley shows great originality in design and is in remarkable harmony with its surroundings. The inspiration was clearly furnished by the old Spanish missions, but it has an individuality and a subtle fitness to its site and to its uses as a private dwelling that make it a most unusual house. The architect has handled the problem with great skill. The exterior is simple, but there is enough variation in color and mass to make it exceedingly interesting. The plan of the interior is compact, convenient and well arranged

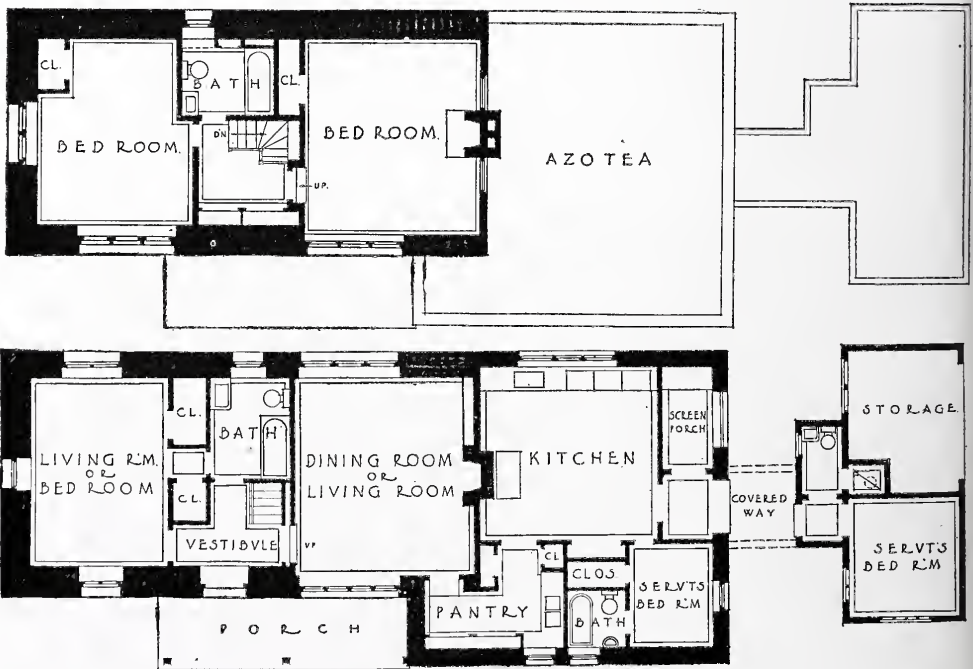

FIRST AND SECOND FLOOR PLANS—"LA CABANA," RESIDENCE AT MONTECITO, CAL., OF BERTRAM GROSVENOR GOODHUE, ARCHITECT.



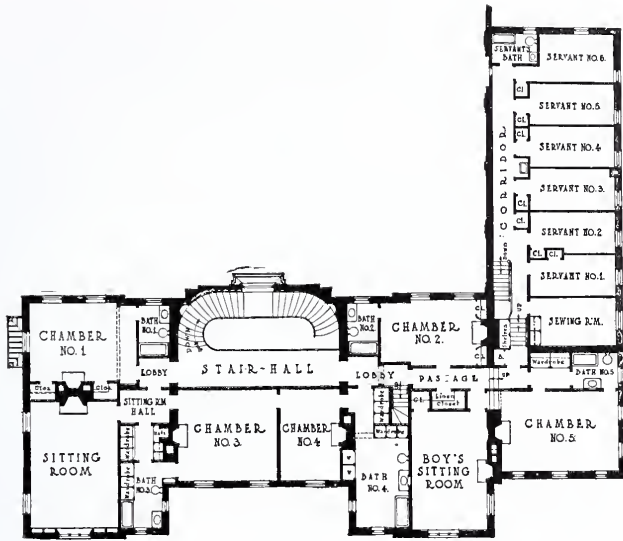

SECOND FLOOR PLAN

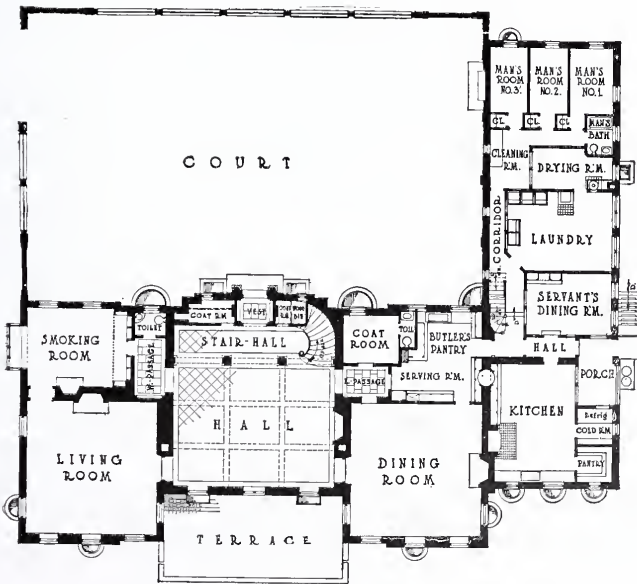

FIRST FLOOR PLAN

RESIDENCE OF PHILIP SEARS, ESQ., BROOKLINE,  
 MASS. BIGELOW & WADSWORTH, ARCHITECTS.



DETAIL OF ENTRANCE—RESIDENCE OF PHILIP SEARS, ESQ.,  
BROOKLINE, MASS. BIGELOW & WADSWORTH, ARCHITECTS.





FRONT VIEW—RESIDENCE OF PHILIP SEARS, ESQ., BROOK-  
LINE, MASS. BIGELOW & WADSWORTH, ARCHITECTS.



HALL, TOWARD STAIRS—RESIDENCE OF PHILIP SEARS, ESQ.,  
BROOKLINE, MASS. BIGELOW & WADSWORTH, ARCHITECTS.





HALL, TOWARD DINING ROOM—RESIDENCE OF PHILIP SEARS, ESQ.,  
BROOKLINE, MASS. BIGELOW & WADSWORTH, ARCHITECTS.



LIBRARY—RESIDENCE OF PHILIP SEARS, ESQ., BROOKLINE, MASS.  
Bigelow & Wadsworth, Architects.



DEN—RESIDENCE OF PHILIP SEARS, ESQ., BROOKLINE, MASS.  
Bigelow & Wadsworth, Architects.





DINING ROOM—RESIDENCE OF PHILIP SEARS, ESQ., BROOK-  
LINE MASS. BIGELOW & WADSWORTH, ARCHITECTS.



VIEW FROM FORECOURT—RESIDENCE OF  
GUERNSEY CURRAN, ESQ., OYSTER BAY,  
L. I. GUY LOWELL, ARCHITECT.





VIEW FROM FORECOURT—RESIDENCE OF  
GUERNSEY CURRAN, ESQ., OYSTER BAY,  
L. I. GUY LOWELL, ARCHITECT.





VIEW FROM WEST TERRACE—RESIDENCE  
OF GUERNSEY CURRAN, ESQ., OYSTER  
BAY, L. I. GUY LOWELL, ARCHITECT.





VIEW FROM EAST APPROACH—RESIDENCE  
OF GUERNSEY CURRAN, ESQ., OYSTER  
BAY, L. I. GUY LOWELL, ARCHITECT



GARDEN, FROM TEA HOUSE—RESIDENCE  
OF GUERNSEY CURRAN, ESQ., OYSTER  
BAY, L. I. GUY LOWELL, ARCHITECT.





FIRST FLOOR PLAN

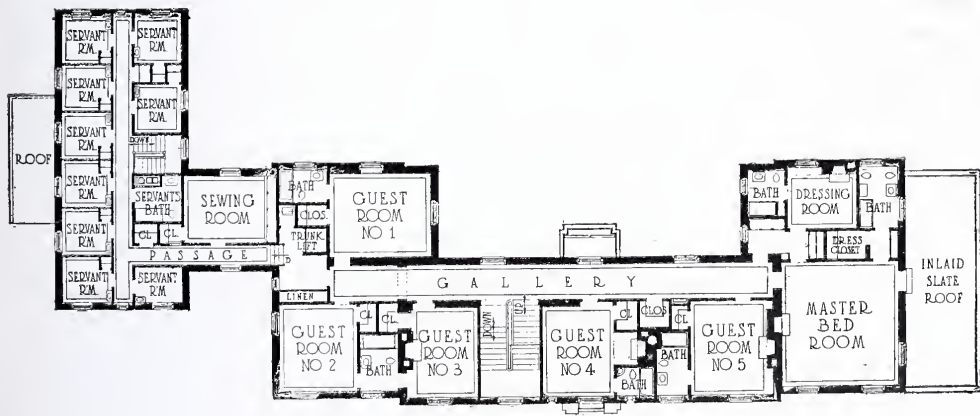

SECOND FLOOR PLAN

RESIDENCE OF GUERNSEY CURRAN, ESQ.,  
 OYSTER BAY, L. I. GUY LOWELL, ARCHITECT.



FIREPLACE IN ENTRANCE HALL—RESIDENCE  
OF GUERNSEY CURRAN, ESQ., OYSTER  
BAY, L. I. GUY LOWELL, ARCHITECT.





DINING ROOM—RESIDENCE OF GUERNSEY CURRAN,  
ESQ., OYSTER BAY, L. I. GUY LOWELL, ARCHITECT.



MAIN ENTRANCE—RESIDENCE OF T.  
R. COFFIN, ESQ., SAN MARINO, CAL.  
REGINALD D. JOHNSON, ARCHITECT.





ENTRANCE THROUGH THE GARDEN.—RESIDENCE OF T. R. COFFIN, ESQ., SAN MARINO, CAL. REGINALD D. JOHNSON, ARCHITECT.

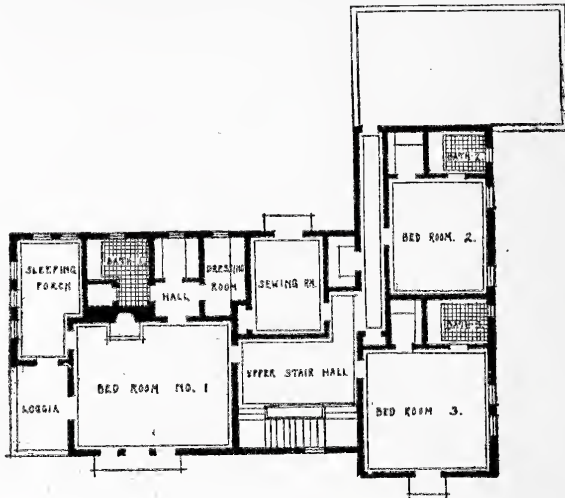

SECOND FLOOR PLAN

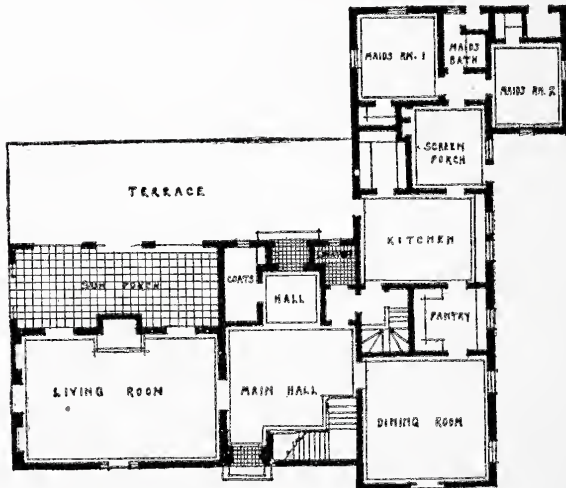

FIRST FLOOR PLAN

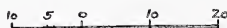

HOUSE FOR - MR. T. R. COFFIN  
 SAN MARINO - CALIF.  
 REGINALD D. JOHNSON - ARCHITECT  
 PASADENA - CALIF.



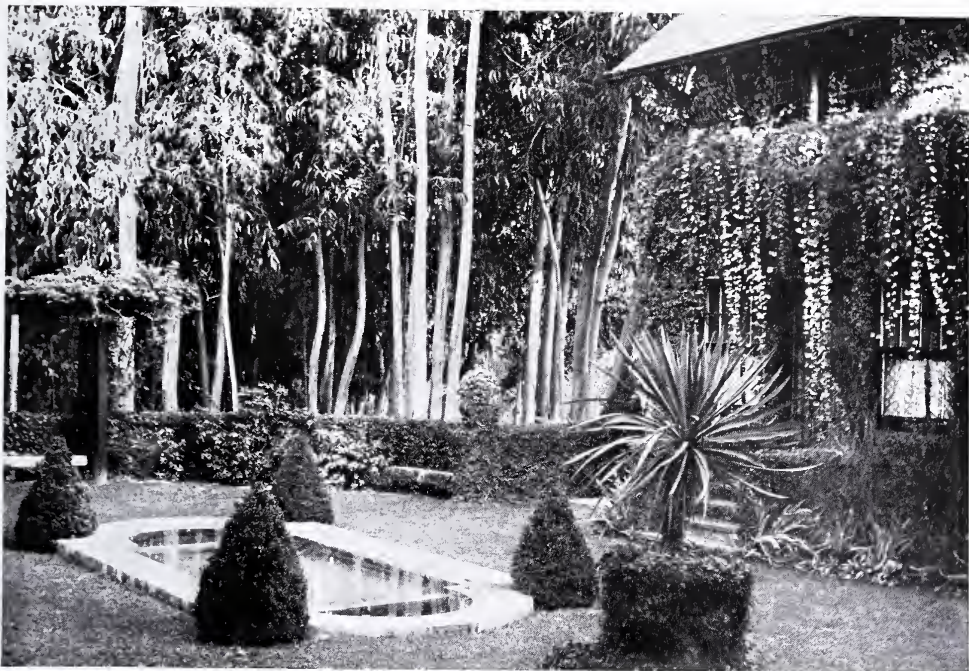

THE PATIO—"GLEN-ORR," RESIDENCE OF WILLIAM MEADE ORR, ESQ., ALHAMBRA, CAL.  
Hunt & Burns, Architects.

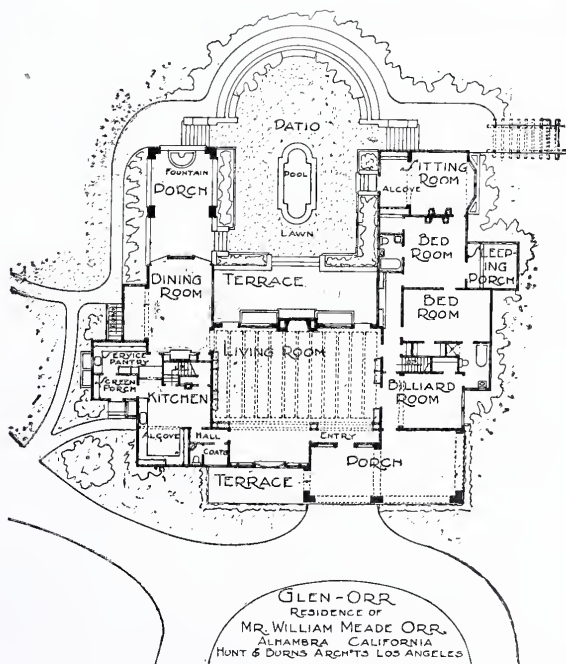

GROUND PLAN—"GLEN-ORR," RESIDENCE OF WILLIAM MEADE ORR, ESQ.,  
ALHAMBRA, CAL.

Hunt & Burns, Architects.





THE CLOCK GREEN—"GLEN-ORR," RESIDENCE OF WILLIAM MEADE ORR, ESQ., ALHAMBRA, CAL. HUNT & BURNS, ARCHITECTS. CHARLES G. ADAMS, LANDSCAPE ARCHITECT



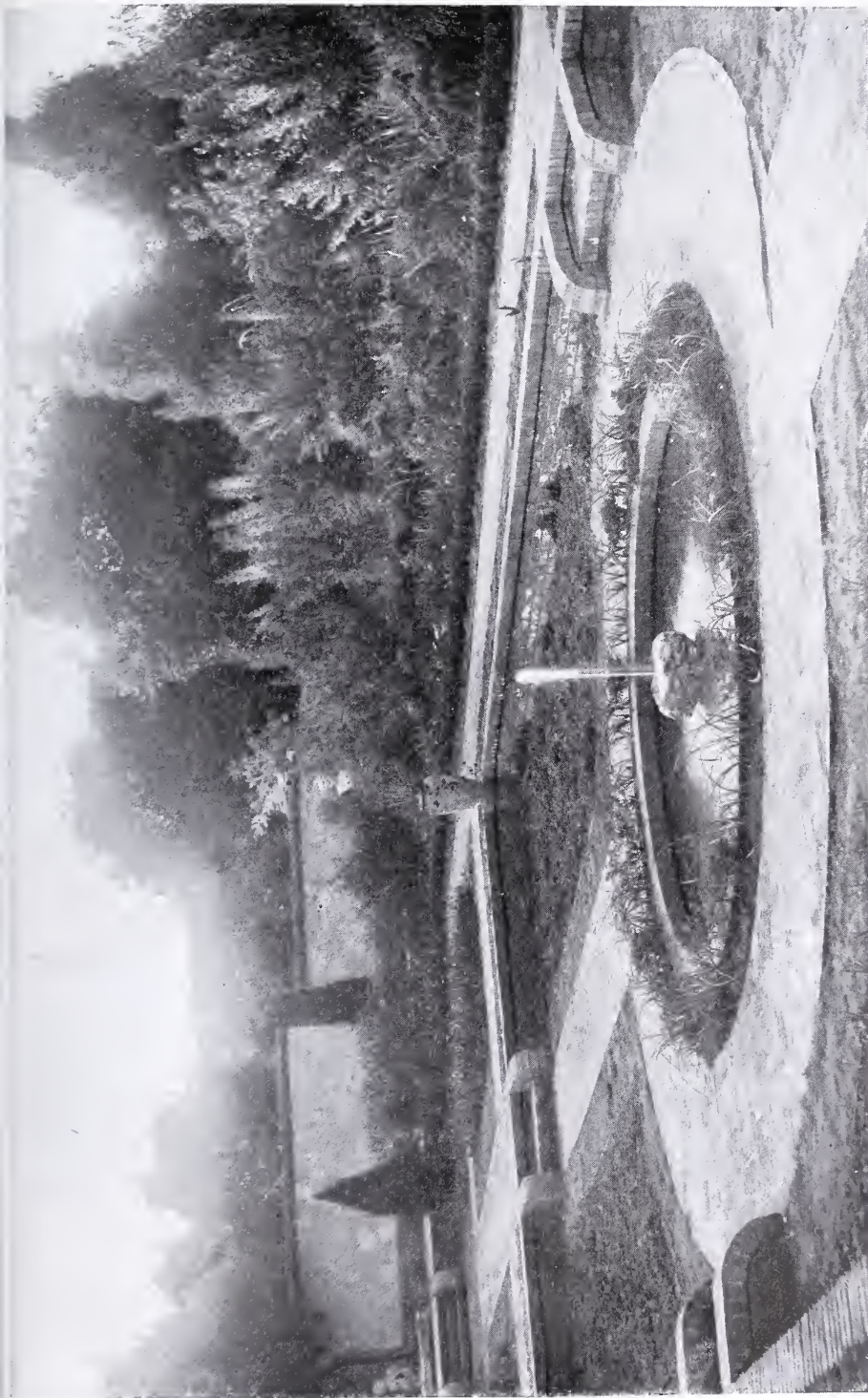

THE WALLED GARDEN—"GLEN-ORR," RESIDENCE OF WILLIAM MEADE ORR, ESQ., ALHAMBRA, CAL. HUNT & BURNS, ARCHITECTS. CHARLES G. ADAMS, LANDSCAPE ARCHITECT.



FOUNTAIN—"GLEN-ORR," RESIDENCE OF WILLIAM MEADE ORR, ESQ., ALHAMBRA, CAL. HUNT & BURNS, ARCHITECTS. CHARLES G. ADAMS, LANDSCAPE ARCHITECT.





THE SECRET GARDEN—"GLEN-ORR," RESIDENCE OF WILLIAM MEADE ORR, ESQ., ALHAMBRA, CAL. HUNT & BURNS, ARCHITECTS. CHARLES G. ADAMS, LANDSCAPE ARCHITECT.



COURT AND TERRACE—RESIDENCE OF TODD FORD, JR., ESQ., PASADENA, CAL. REGINALD D. JOHNSON, ARCHITECT.



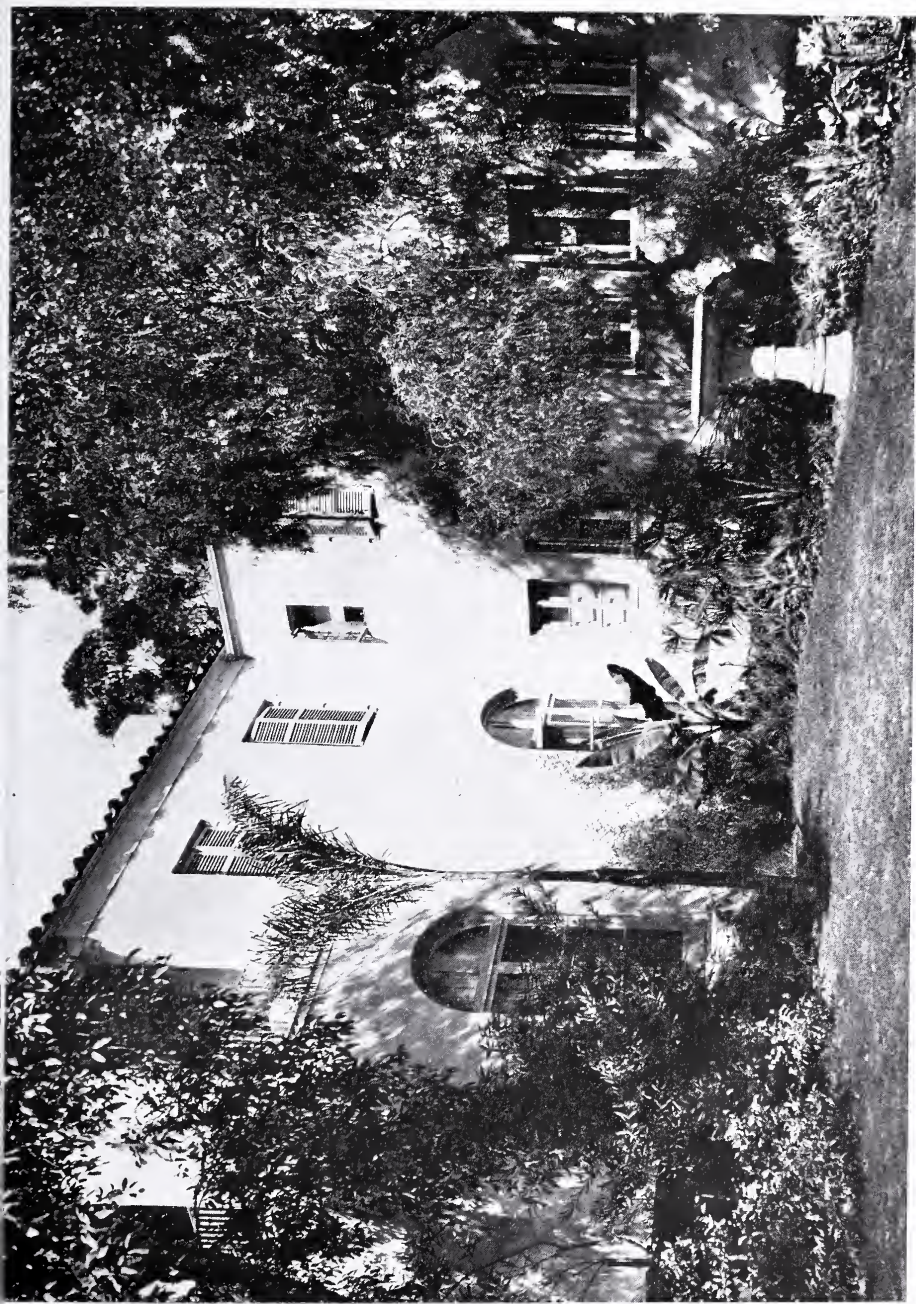

RESIDENCE OF TODD FORD, JR., ESQ., PASA  
DENA, CAL. REGINALD D. JOHNSON, ARCHITECT

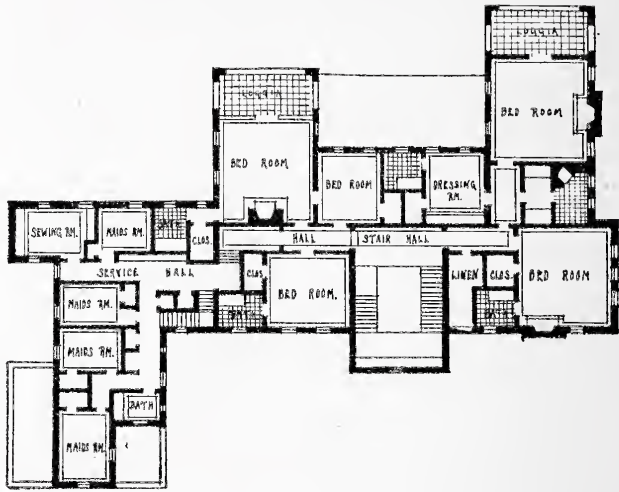

SECOND FLOOR PLAN

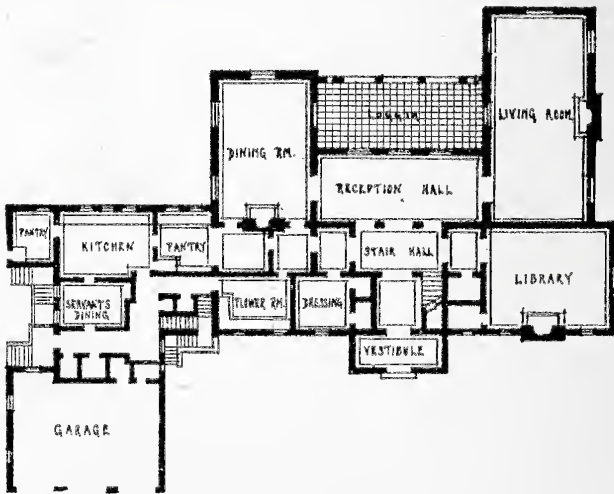

FIRST FLOOR PLAN

SCALE  $\overline{\text{10 5 0 10 20}}$  FEET

HOUSE FOR - MR. TOD. FORD JR.  
 PASADENA - CALIF.  
 REGINALD D. JOHNSON - ARCHITECT  
 PASADENA - CALIF.





LOGGIA—RESIDENCE OF TODD FORD, JR., ESQ., PASADENA, CAL. REGINALD D. JOHNSON, ARCHITECT.

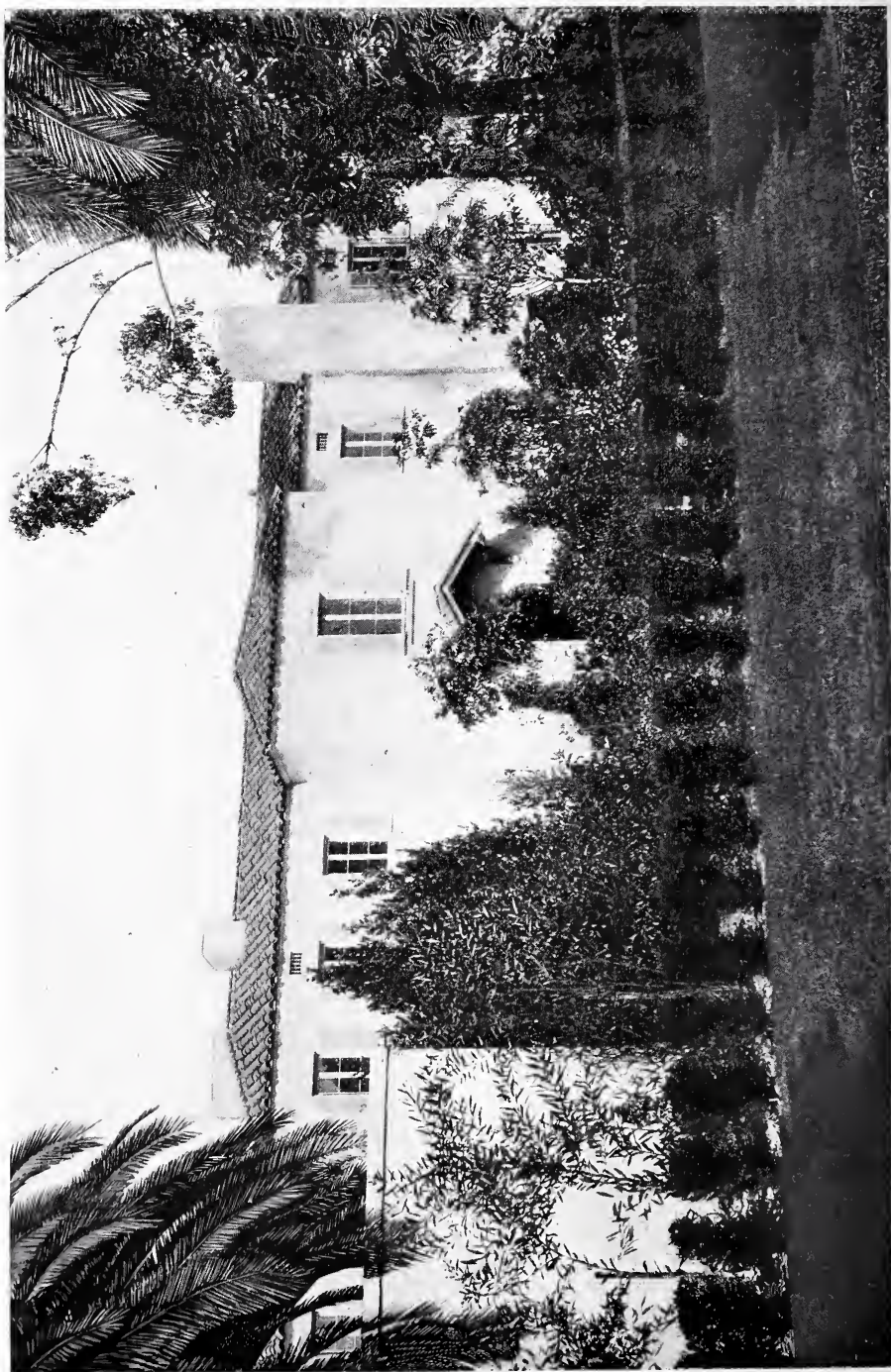

RESIDENCE OF TODD FORD, JR., ESQ., PASADENA, CAL. REGINALD D. JOHNSON, ARCHITECT.





FRONT VIEW—"THE CLOSE," RESIDENCE OF HENRY  
B. BINNSE, ESQ., SHORT HILLS, N. J. BAILLIE SCOTT,  
ARCHITECT; F. E. TAPPAN, ASSOCIATE ARCHITECT.



"THE CLOSE," RESIDENCE OF HENRY B. BINNSE, SHORT HILLS, N. J.  
Baillie Scott, Architect; F. E. Tappan, Associate Architect.



"THE CLOSE," RESIDENCE OF HENRY B. BINNSE, SHORT HILLS, N. J.  
Baillie Scott, Architect; F. E. Tappan, Associate Architect.





PASSAGE WINDOW, FROM COURT—"THE CLOSE," RESIDENCE  
OF HENRY B. BINNSE, ESQ., SHORT HILLS, N. J. BAILLIE  
SCOTT, ARCHITECT; F. E. TAPPAN, ASSOCIATE ARCHITECT.





KITCHEN SIDE—"THE CLOSE," RESIDENCE OF HENRY B. BINNSE, ESQ., SHORT HILLS, N. J. BAILLIE SCOTT, ARCHITECT; F. E. TAPPAN, ASSOCIATE ARCHITECT.



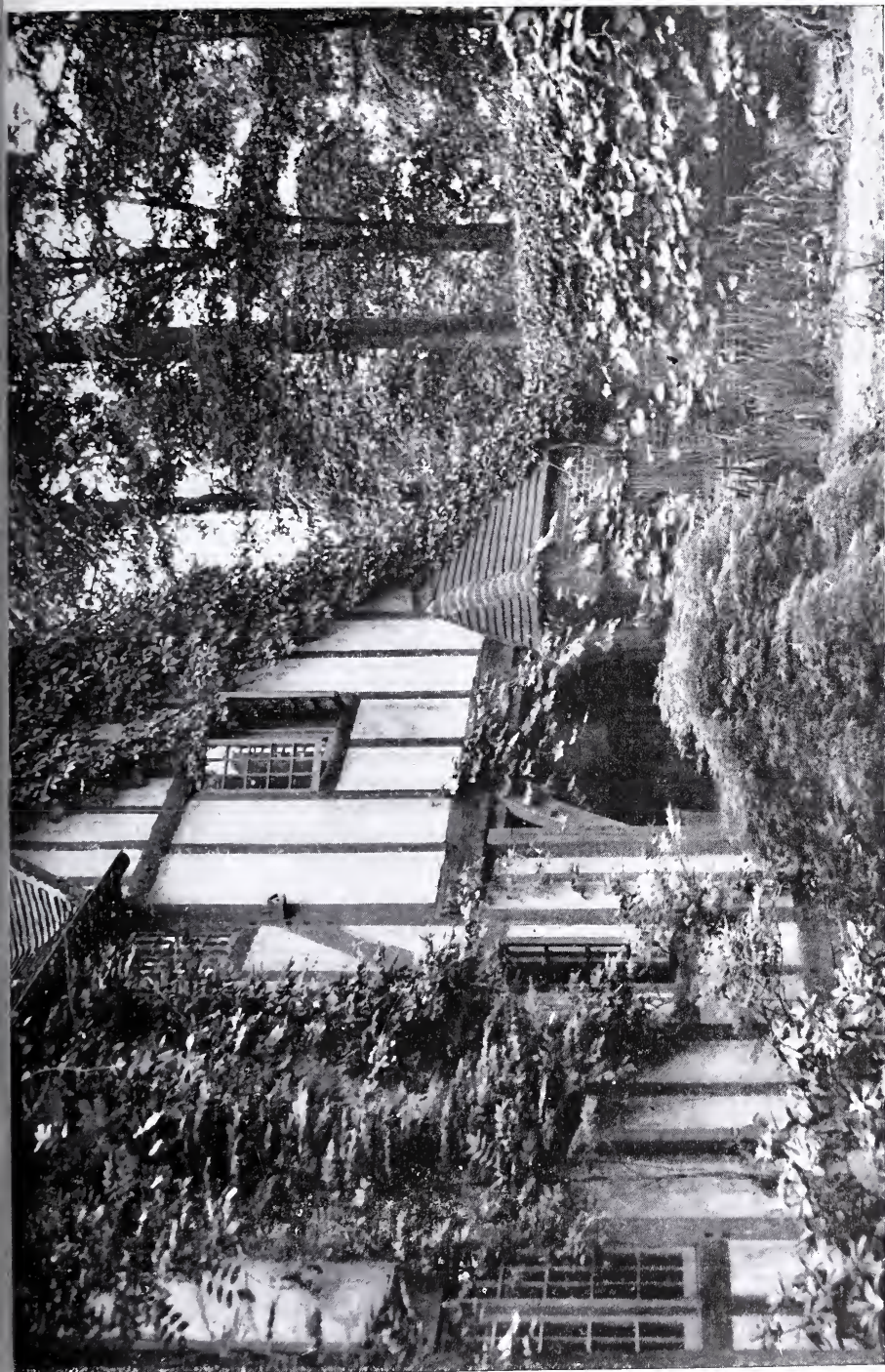

COVERED WAY TO KITCHEN ENTRANCE—"THE CLOSE," RESIDENCE OF HENRY B. BINNSE, ESQ., SHORT HILLS, N. J. BAILLIE SCOTT, ARCHITECT. F. E. TAPPAN, ASSOCIATE ARCHITECT.





EAST SIDE WITH COVERED WAY AND GARAGE—"THE CLOSE,"  
RESIDENCE OF HENRY B. BINNISE, ESQ., SHORT HILLS, N. J.  
BAILLIE SCOTT, ARCHITECT; F. E. TAPPAN, ASSOCIATE ARCHITECT.



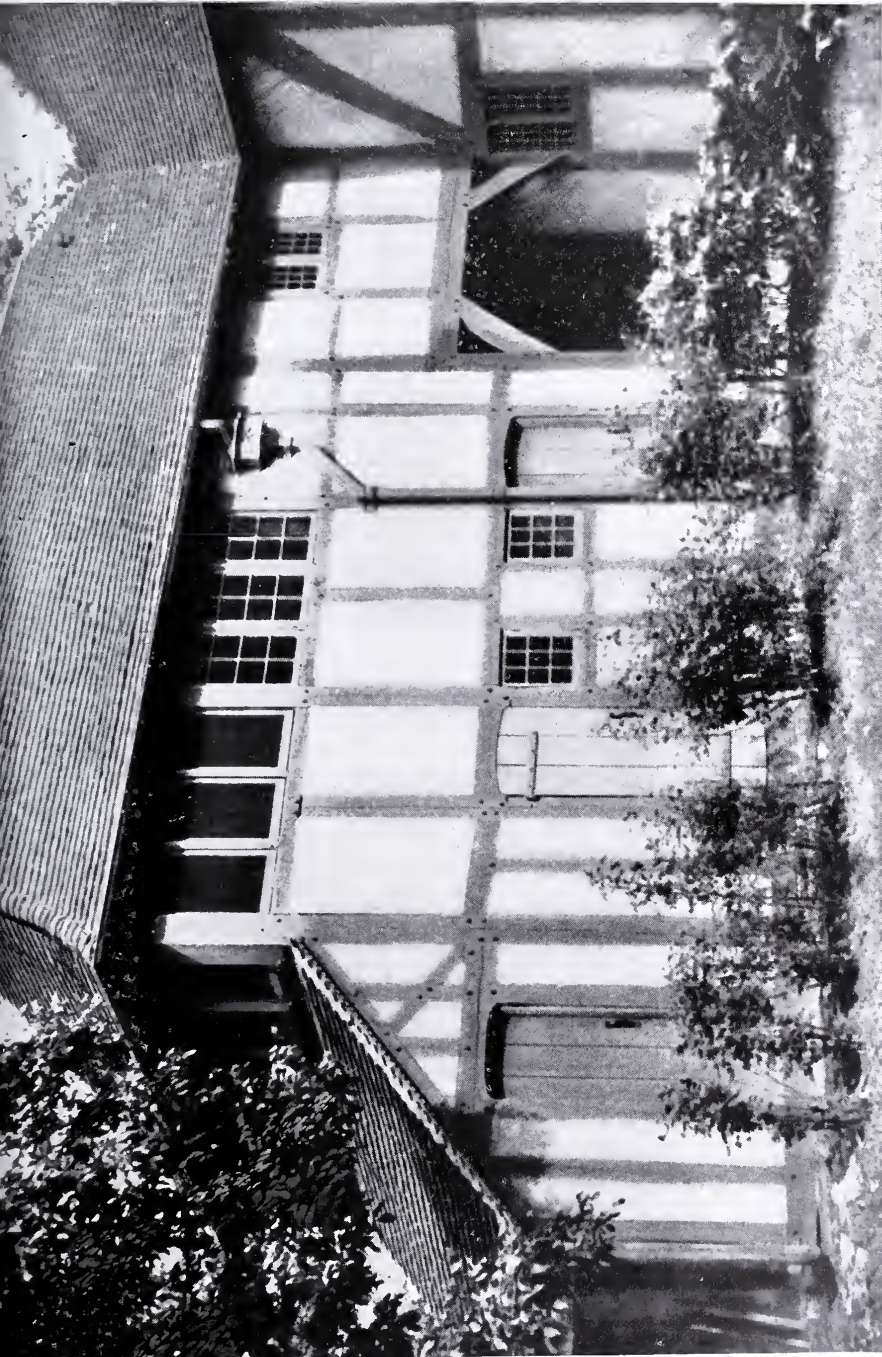

GARAGE AND SLEEPING PORCH, FROM COURT—"THE CLOSE,"  
RESIDENCE OF HENRY B. BINNSE, ESQ., SHORT HILLS, N. J.  
BAILLIE SCOTT, ARCHITECT; F. E. TAPPAN, ASSOCIATE ARCHITECT.





LIVING ROOM WINDOW—"THE CLOSE," RESIDENCE OF HENRY B. BINNSE, ESQ.,  
SHORT HILLS, N. J.  
Baillie Scott, Architect; F. E. Tappan, Associate Architect.



FIREPLACE IN LIVING ROOM—"THE CLOSE," RESIDENCE OF HENRY B. BINNSE, ESQ.,  
SHORT HILLS, N. J.  
Baillie Scott, Architect; F. E. Tappan, Associate Architect.





GARDEN FRONT—RESIDENCE OF ANDREW  
V. STOUT, ESQ., RED BANK, N. J.  
JOHN RUSSELL POPE, ARCHITECT.



DETAIL OF RIVER FRONT, OVERLOOKING THE SHREWSBURY—RESIDENCE OF ANDREW V. STOUT, ESQ., RED BANK, N. J. JOHN RUSSELL POPE, ARCHITECT.





RIVER FRONT—RESIDENCE OF ANDREW V. STOUT, ESQ.,  
RED BANK, N. J. JOHN RUSSELL POPE, ARCHITECT.





GARDEN PORCH—RESIDENCE OF ANDREW  
V. STOUT, ESQ., RED BANK, N. J.  
JOHN RUSSELL POPE, ARCHITECT.





DOORWAY OF GARDENER'S COTTAGE—ESTATE OF ANDREW V. STOUT, ESQ.

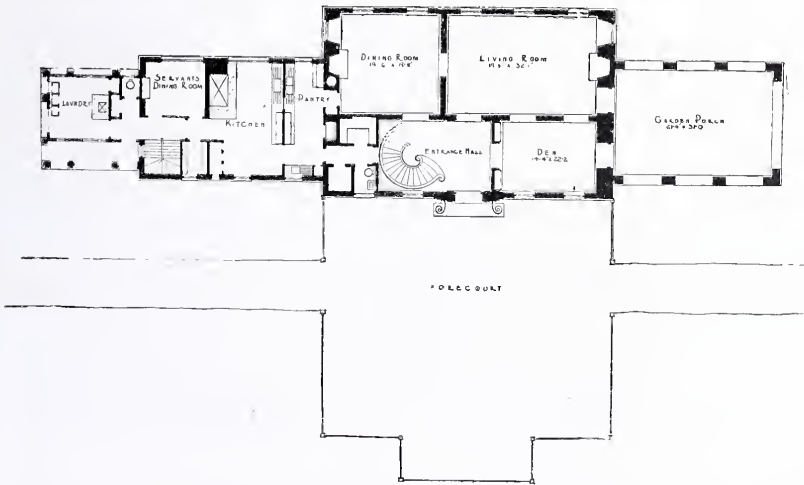

FIRST FLOOR PLAN—RESIDENCE OF ANDREW V. STOUT, ESQ., RED BANK, N. J.  
John Russell Pope, Architect.



DINING ROOM FIREPLACE—RESIDENCE OF  
ANDREW V. STOUT, ESQ., RED BANK,  
N. J. JOHN RUSSELL POPE, ARCHITECT.





LIVING ROOM FIREPLACE, WITH WEATHER DIAL IN  
OVERMANTEL—RESIDENCE OF ANDREW V. STOUT, ESQ.,  
RED BANK, N. J. JOHN RUSSELL POPE, ARCHITECT.



MAIN STAIR—RESIDENCE OF ANDREW  
V. STOUT, ESQ., RED BANK, N. J.  
JOHN RUSSELL POPE, ARCHITECT.





ENTRANCE SIDE--RESIDENCE OF WILLARD P. LINDLEY, ESQ., SANTA BARBARA, CAL.  
George Washington Smith, Architect.

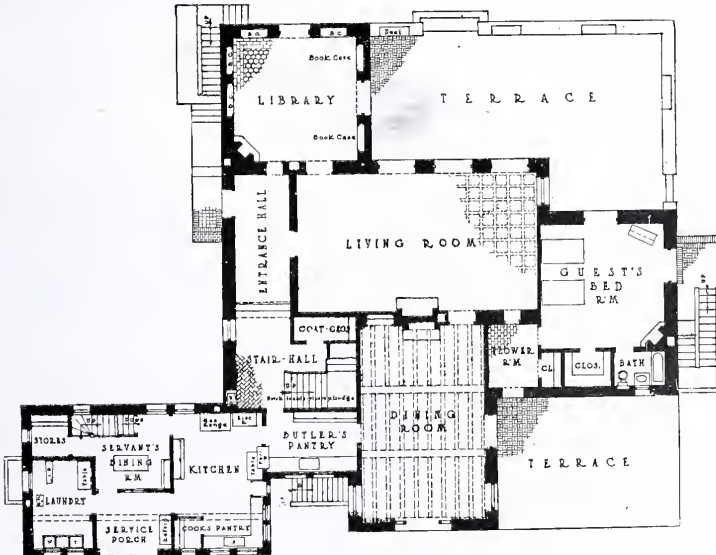

FIRST FLOOR PLAN

RESIDENCE OF WILLARD P. LINDLEY, ESQ., SANTA BARBARA, CAL.  
George Washington Smith, Architect.



OUTSIDE STAIRWAY AND LOGGIA—RESIDENCE OF WILLARD P. LINDLEY, ESQ.,  
SANTA BARBARA, CAL.

George Washington Smith, Architect.

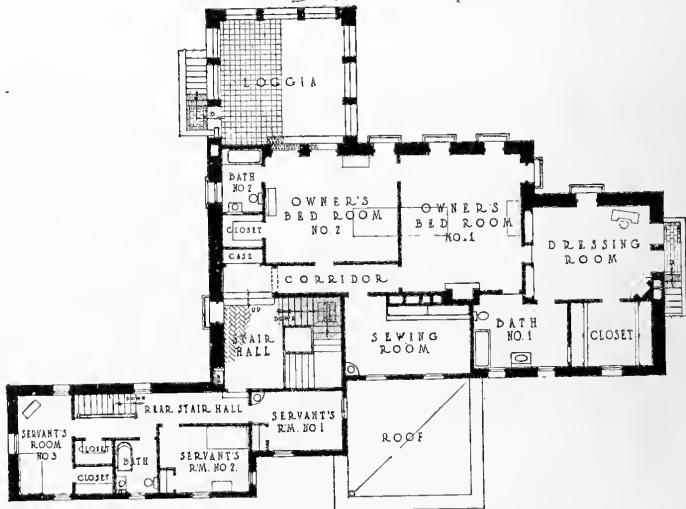

SECOND FLOOR PLAN  
RESIDENCE OF WILLARD P. LINDLEY, ESQ., SANTA BARBARA, CAL.  
George Washington Smith, Architect.





THE GARDEN TERRACE—RESIDENCE OF WILLARD P. LINDLEY, ESQ.,  
SANTA BARBARA, CAL.  
George Washington Smith, Architect.



RESIDENCE OF WILLARD P. LINDLEY, ESQ., SANTA BARBARA, CAL.  
George Washington Smith, Architect.



DRAWING ROOM—RESIDENCE OF WILLARD  
P. LINDLEY, ESQ., SANTA BARBARA, CAL.  
GEORGE WASHINGTON SMITH, ARCHITECT.





DRAWING ROOM—RESIDENCE OF WILLARD  
P. LINDLEY, ESQ., SANTA BARBARA, CAL.  
GEORGE WASHINGTON SMITH, ARCHITECT.

from the point of view of exposure, cross draughts and service.

The first illustration, on page 361, gives a good general view of the house. The mass against the sky is made more interesting by the tile roofs and by the varied and lovely trees about it. The window spacing is delightful and the open loggia adds variety to the simple stucco wall treatment. The stucco itself is of a slightly varied surface that gives a delicate play of light and shade over the plain wall spaces. The touches of brick in the steps add a note of bright color, and the statuette over the door, lighted by a charming wrought iron lantern, centers the interest at this point.

The interior lives up to the high promise of the exterior. The dignity and simplicity of treatment of the rooms themselves is most attractive. The ceiling in the living room is made of squares formed by intersecting beams; and it is interesting to note that there is no cornice around the room—the beams rest directly on the rough plaster walls. Nor is there any trim about the windows and doors. The plain reveals of plaster are softened by the long, rich folds of the curtains of monk's cloth. The delicate character of the furniture is in marked contrast to the almost rough treatment of the walls. The whole effect is harmonious and homelike. On one side of the room there is a mantelpiece with slanting hood and large opening, flanked by delightful Italian wall lighting fixtures and furniture.

The plan of the house is worthy of study. There is practically no waste space and yet no element of comfort is omitted, and most of the rooms are ventilated from at least two directions. The transition from the interior to the out-of-doors is unusually well arranged. The terraces and loggia and outside staircases make the house and its gardens seem like one harmonious whole.

Mr. Pope has designed and executed another vital and original piece of work in the house for Mr. Andrew V. Stout at Red Bank, N. J. (page 353). The style is a free use of our own fine Colonial traditions, handled in an authoritative and consistent way. The effect is simple, but it is a consummate piece of art. The mass is fine, and the spacing of the windows and the proportions of the stones give the impression that it had to be just that way; it is direct and natural.

It would be hard to find a stairway so simple and yet so beautiful as the spiral flight in the main hall. It is the embodiment of grace itself; the care, the labor and the difficulty of doing such a piece of work is not even felt.

Of particular note are the details of the entrance doors, the fireplace treatments in the drawing room and the dining room, and the beautiful lattices which decorate the piers of the service wing and the outdoor porch. Another interesting motive is the really lovely bird bath raised on flat steps from the lawn on the garden side.



# Problems of Building of Today



Every question has two sides, and if it be said that the difficulties of getting labor and material and the excessively high costs of the markets today make it inadvisable to build, it is at least well to consider the other phases of this important subject. Rents are high, existing buildings are everywhere bringing more than they would have two or three or ten years ago. If you have to pay more in rent or in buying an old house, getting something that does not suit you in any case, than if you built for yourself what you want, then it would seem to be economical to build now.

Building costs have doubled and, under certain conditions and in certain localities, have been trebled since 1914; that is to say, a certain house with certain kinds of materials would cost three times as much today as it would have six years ago. This statement is constantly being made. It is true. Yet, paradoxically, it is very misleading. There are certain considerations which give it a different meaning.

The fundamental, big difference between the prices of yesterday and the prices of today is that one dollar today is worth only about fifty cents of the value of 1914. Our currency has been inflated and our standard of exchange depreciated. For one thing we may be thankful—that it has not depreciated anything like as much as in any country abroad.

Some materials have advanced twice, some three times, and some even six times their former value. On the other hand, some materials have changed but little, and others have not changed at all. As an illustration of this, wood, including beams, studs, flooring and trim have gone up, while local field stones taken from an old dry wall cost not a cent more today. Within the last two months

I was interested in taking bids on a certain house, getting one estimate on wood and shingle walls, and one estimate on heavy stone walls built of fine flat field stones, of which there were an abundance at the site.

The wood house cost \$29,000, the stone house \$33,000, the difference being only \$4,000.

The wood house was similar to another which was built in 1912 for \$12,000, so that this type of construction had almost trebled. The stone house at that time would have cost \$24,000, so that this type of construction had increased less than one-third in cost. This shows clearly that if one wants a wood house and can only pay the price of 1914, one is running in bad luck; but for a stone house the matter is not so serious.

Certain particular conditions enter into this state of affairs. It so happens in some localities that the masons have not much work, and there is a good supply of excellent Italian workmen to be had, also the shortage of rough lumber and finishing lumber is very acute.

The excessive costs of today may be met successfully in several ways: first, by studying the plan to use economical lengths of span, avoiding any complicated framing, and making the construction as simple and direct as possible; second, eliminating all superfluous materials, cutting down the amount of trim, moulded work and elaborate detail, except where it is going to really count; and third, using the materials which today are less expensive, as for instance beech or maple flooring instead of oak.

One economy which is being practised, not only in private houses but also in the large Park Avenue apartment houses today, is the elimination of wood archi-

traves or trim about the windows and panels below the window sills, on the theory that this woodwork is always covered up by curtains. Then a comparison of such utilitarian fittings as the kitchen and pantry dresser shows an almost comic difference between the fashions of 1914 and 1920. Not a sixteenth of an inch of superfluous wood is used, and yet they hold the dishes quite as well and look very much neater.

To explain the high cost of one class of work only, take the example of moulded work or mill work. During the war about one hundred small mills and shops around New York went out of business or were put out of business for one reason or another; only the big planing mills survived. These are now swamped with work, and while they were, as a general thing, more expensive than the small shops before, they now charge prices out of all reason for the work done. Similar fundamental changes due to different causes have taken place in most of the other branches, such as stone quarrying, cement manufacture and brick burning.

The most practical solution for the client that I have found, however, is the initiation of a new service in my office, which I believe has also been taken up by a number of other architects: first, making a careful survey and list of all materials going into the building; second, purchasing certain of these materials directly for the client; third, getting a good superintendent who hires the workmen and oversees the men, coordinating all the trades and looking after the work in detail; fourth, supplying an office administration for following up the orders and seeing that the proper men and materials are ready and delivered at the site before they are needed, keeping track of estimates and accounts and keeping a general supervision of the work; and, fifth, letting such contracts or minor contracts as may be advisable, as mill work, plumbing, heating, electric or painting work.

By clever purchasing of lumber and mill work, for instance, I have found that local prices can be cut in half in certain cases. Better bargains can usually be

made for minor contracts, such as are noted above and for the purchase of materials on behalf of an owner who has good credit than when made through a contractor, as payments are made directly by the owner, insuring promptness and guaranteeing certainty of such payments. The profit of the general contractor is eliminated, usually amounting to ten per cent. or fifteen per cent. of the cost, and a large proportion in the overhead cost which is always added in by the contractor as cost of the work. By these means, briefly noted above, theoretically, and I have also found practically, the cost of work can be reduced from twenty per cent. to fifty per cent., depending on the size and the character of the work.

In carrying a building on in this way it is of great importance that, first of all, the drawings and specifications should be carefully worked out and understood and approved by the owner; second, that accurate estimates be made covering all parts of the construction; third, that changes in the plan and scope of the work should be avoided; and, fourth, that the progress and efficiency of the work should be closely watched and followed up in great detail.

All this adds greatly to the responsibility of the architect; but it is a service which, if faithfully rendered, is of great value and one which simplifies the problem to the prospective owner. It is, further, a service which is a contribution to the whole community, I believe, and in part solves one of the most difficult economic problems this country has to face today.

The problems of the difficulty of building and the high cost of building cannot be solved by inertia or simply waiting for conditions to right themselves. A sane, economical program of building, encouraging the production of all kinds of materials, and economical purchasing that at the same time requires a high standard in the various products and in the labor used in assembling them, are the only ways to set in motion again the wheels of industry towards supplying the demands that have been pyramiding for the last four years.



THE  
ARCHITECTURAL  
RECORD

NOVEMBER 1920



PUBLISHED IN NEW YORK  
35¢ A COPY \$ 3.00 A YEAR



# BISHOPRIC SUGGESTIONS:

OLD HOMES MADE NEW - NEW HOMES MADE BETTER

Exterior Details for use in Overcoating  
Old Frame Buildings on Bishopric Stucco Base

Send for Special Loose-leaf Portfolio for Architects

THE BISHOPRIC MANUFACTURING CO., 102 Este Avenue, Cincinnati, O.

**BISHOPRIC SHEATHING.**— Strengthening, insulating, sound-deadening, weather-proofing unit; for exterior walls, sub-flooring and sub-roofing.  
**BISHOPRIC STUCCO AND PLASTER BASE.**— Interlocking dovetailed key, insulating and waterproofing unit; creosote treated and not treated.

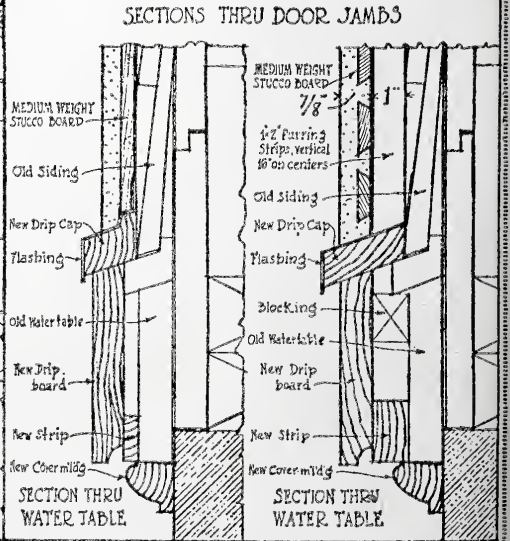
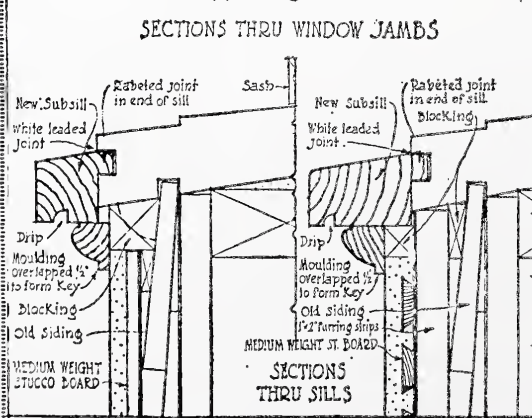
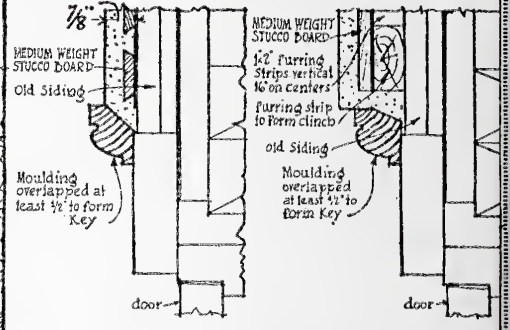
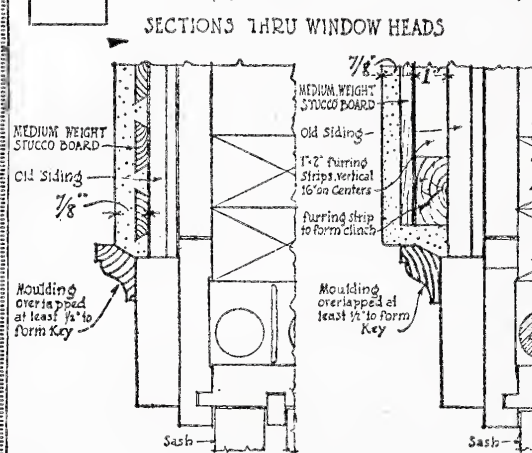
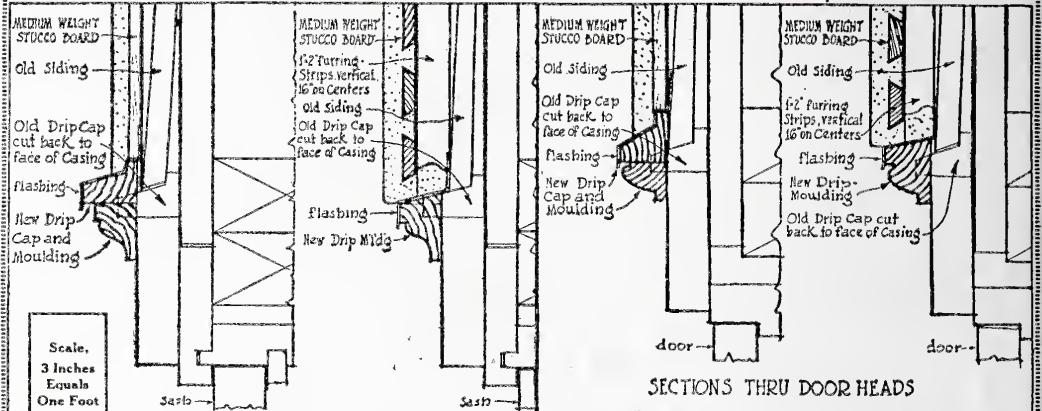

3" SCALE DETAILS OF WINDOWS FOR USE WITH STUCCO BOARD AND STUCCO BOARD AND FURRING

3" SCALE DETAILS OF DOORS & WATERTABLES FOR USE WITH STUCCO BOARD AND STUCCO BOARD AND FURRING



# THE ARCHITECTURAL RECORD



Vol. XLVIII. No. 5

NOVEMBER, 1920

Serial No. 266

Editor: MICHAEL A. MIKKELSEN

Contributing Editor: HERBERT CROLY

Business Manager: J. A. OAKLEY

	PAGE
COVER—The Ohio Stadium. From Original Drawing <i>By Howard Dwight Smith</i>	371
RESIDENCE OF MRS. B. F. PEPPER, Chestnut Hill, Pa.: Willing & Sims, Architects <i>By William Lawrence Bottomley</i>	385
THE OHIO STADIUM, at Ohio State University <i>By Howard Dwight Smith</i>	407
BUILDING A NATION: Social Aspects of England's Housing Program <i>By Lawrence Veiller</i>	417
IS IT ADVISABLE TO REMODEL SLUM TENEMENTS? <i>By Andrew J. Thomas—With Comment by Robert D. Kohn</i>	427
RECENT DEVELOPMENTS IN HOUSING FINANCE. Part I <i>By John Taylor Boyd, Jr.</i>	433
RIVERDALE COUNTRY CLUB, New York City: Dwight James Baum, Architect <i>By Michael A. Mikkelsen</i>	441
L'OMBRELLINO, near Florence, Italy <i>By Harold Donaldson Eberlein</i>	452
A BIBLIOGRAPHY OF MUSEUMS <i>By Charles Over Cornelius</i>	461
NOTES AND COMMENTS	

Yearly Subscription: United States, \$3.00; Foreign, \$4.00; Single Copies, 35 cents. Copyright, 1920, by The Architectural Record Co. All rights reserved. Member Audit Bureau of Circulation.

PUBLISHED MONTHLY BY  
**THE ARCHITECTURAL RECORD COMPANY**

115-119 WEST FORTIETH STREET, NEW YORK.

T. S. MORGAN, Pres.    W. D. HADSELL, Vice-Pres.    E. S. DODGE, Vice-Pres.    J. W. FRANK, Sec'y-Treas.



FOUNTAIN AND TERRACE—RESIDENCE OF  
MRS. B. F. PEPPER, CHESTNUT HILL, PHIL-  
ADELPHIA. WILLING & SIMS, ARCHITECTS.



# THE ARCHITECTURAL RECORD

VOLUME XLVIII



NUMBER V

NOVEMBER, 1920

~ RESIDENCE OF M<sup>RS</sup> B. F. PEPPER ~  
CHESTNUT HILL, PHILADELPHIA  
WILLING & SIMS, ARCHITECTS

By  
WILLIAM LAWRENCE BOTTOMLEY

THE development of style is obscure and slow, but it is as inevitable as Nemesis. It is easy from the perspective of two or three hundred years, looking back at a period, to see its characteristics, to trace its origins and development. On the other hand, when working in a period of great activity and growth, such as the present, it is extremely difficult to gauge its trend or to analyze its spirit.

All the arts in one period have common characteristics which differentiate them from other times. Literature and music, painting, architecture and sculpture are welded together in a unified group by their resemblances. All are closely related, and yet how hard it is to see what these relationships are from

close range. What, for instance, is the influence of the Cubist style of painting upon the work of the sculptors or the architects? Or what common cause is affecting the work of the poets and the musicians? Anyone can see certain outstanding elements that are new to an art, such as the Cubist movement in painting, when it is a striking, a conscious, one might even say a blatant departure. Good or bad, subtle or obvious, the fact remains that here is something new. It causes the most diverse opinions and intense discussions. This kind of a novelty in an art is noted by everyone who is at all interested in that art. Many are puzzled at its cause—some have a consciousness of a similar tendency in another art, as, for example, in

sculpture, where the effect in certain instances is marked; but few people have the analytical faculty, the time or the interest definitely to trace its influence.

Certain characteristics of the style of the house of Mrs. B. F. Pepper, at Chestnut Hill, Pennsylvania, by Messrs. Willing & Sims, architects, of Philadelphia, mark it at once as an unusual and original piece of work, aside from its great charm and distinction. Anyone can see at a glance that it is very beautiful and that it is different from the typical house that is being done today, but it is interesting to search further and see just what are its salient points, what has inspired them, and where else they may be seen. What effect they will have in the future it is almost impossible for anyone to foretell.

There are tendencies in the work of some of the architects today which those who run may read. It is not the work of the academic school. It is a cult of taste, a liking, sometimes a striving, for picturesque effects. In the work of this

new movement one finds a reaching back into the far past, the past of the Gothic or the early Renaissance periods of France, England and Italy. There is a new fondness discernable for old motives dexterously handled, and handled in a new and original way, such as towers, casement windows, curved buttresses and consoles, interesting roof lines and different levels of floors. All of these characteristics may be seen in this new and beautiful American house. They are so cleverly used that the effect is one of perfect unity and balance; and while novel in its composition and treatment, the house undoubtedly is colloquial in its style and fits into its surroundings to perfection.

The fusing of all these foreign motives is accomplished successfully by a just and proper proportion between the different parts, by the use of a consistent scale, and by broad and simple wall surfaces of stone which serve the architect in much the same way as the color scale serves the painter. The result is un-

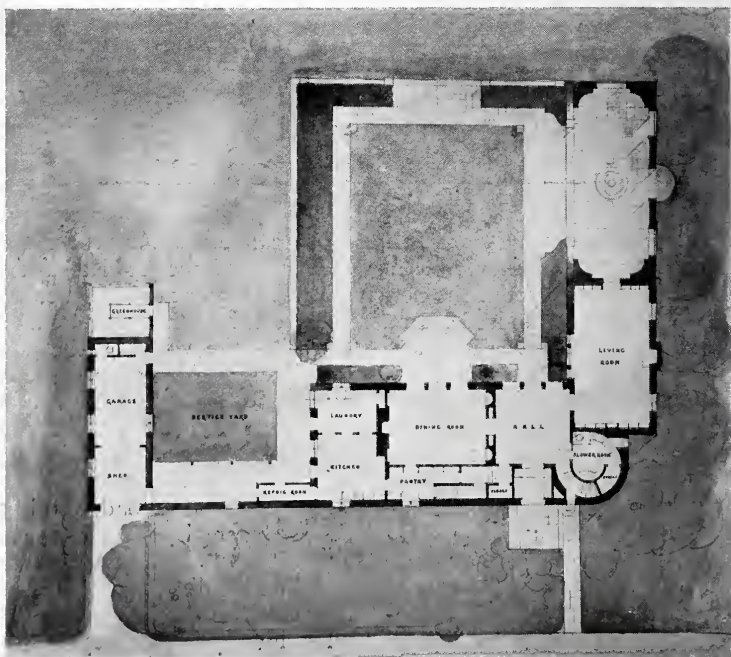

GROUND FLOOR PLAN—RESIDENCE OF MRS. B. F. PEPPER,  
CHESTNUT HILL, PHILADELPHIA.

Willing & Sims, Architects.





MAIN ENTRANCE AND STAIR TOWER—RESIDENCE  
OF MRS. B. F. PEPPER, CHESTNUT HILL,  
PHILADELPHIA., WILLING & SIMS, ARCHITECTS.

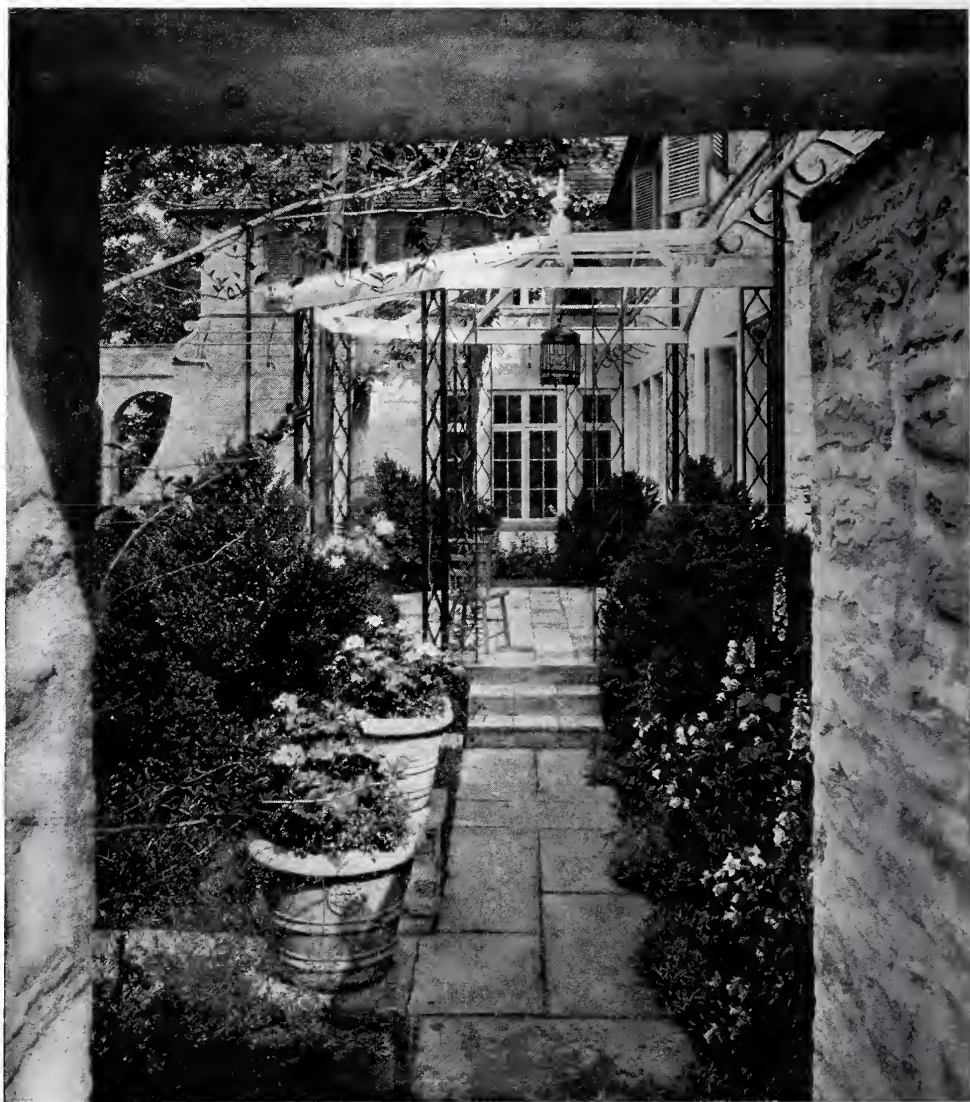

GARDEN, FROM GATE TO GREENHOUSE—RESIDENCE OF MRS. B. F. PEPPER, CHESTNUT HILL, PHILADELPHIA. WILLING & SIMS, ARCHITECTS.



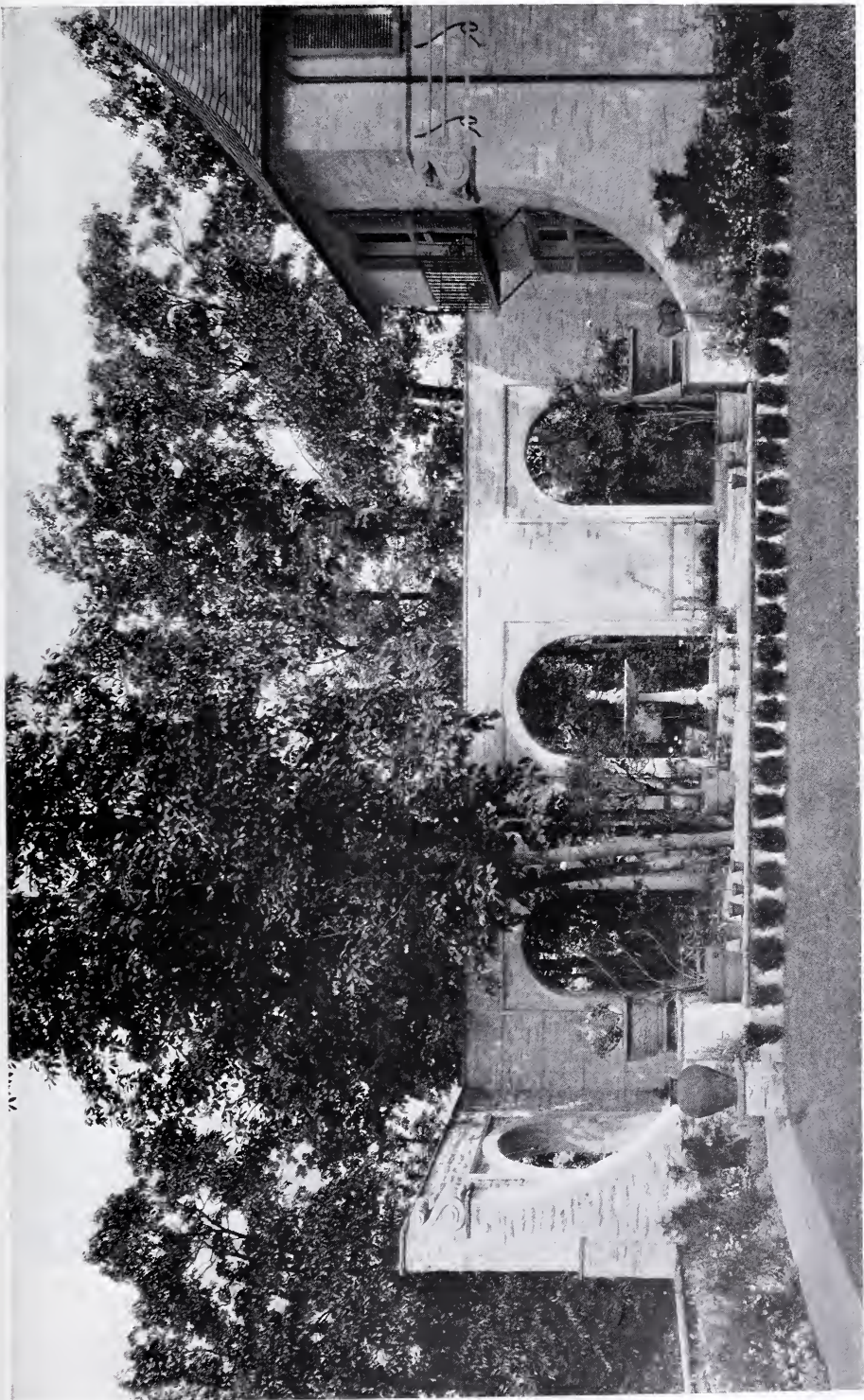

TERRACE--RESIDENCE OF MRS. B. F. PEPPER, CHESTNUT HILL, PHILADELPHIA. WILLING & SIMS, ARCHITECTS.





GARDEN SIDE—RESIDENCE OF MRS. B. F. PEPPER, CHESTNUT HILL, PHILADELPHIA. WILLING & SIMS, ARCHITECTS.





GARDEN ELEVATION—RESIDENCE OF MRS.  
B. F. PEPPER, CHESTNUT HILL, PHILA-  
DELPHIA. WILLING & SIMS, ARCHITECTS.



HALL—RESIDENCE OF MRS. B. F. PEPPER, CHESTNUT HILL, PHILADELPHIA.  
Willing & Sims, Architects.

doubtedly harmonious, when if slightly less skilfully handled it would have been a jumble.

The plan follows the best traditions of country house design in making the gardens an integral part of the whole, as necessary to the composition as they are for the perfect enjoyment of the house. The principal mass of the house contains the hall and the dining room and the service portion, with wings extending from it to form a long L shaped plan. The living room is lengthened by a delightful outside walled garden facing on the garden court, and from the other end of the house the kitchen is linked up with the garage and greenhouse and outhouses by a servants' porch and service court. Both the living room and the dining room give on an enclosed garden to the south and east, the dining room being related to this court by a half octagonal arbor, which forms a delightful shade for out-of-door meals in the summer, while giving full light to the dining room

in the winter part of the year when the leaves are off the trees. It is interesting to notice that the evil, old roofed-in piazza, darkening all the main rooms of the first floor, has entirely disappeared. There is not even a roofed and screened living porch. The rooms are all perfectly lit, have abundant sun, and afford as much outside air when the windows are open as it is possible to get. In bad weather the choice is to remain indoors in comfort, with plenty of air, or put on rainy day clothes and get right out into the weather and get some real exercise. This is a vast gain to the appearance of the house, and it is also logical. Certainly the open arched garden with its sheltered seats and corners is an infinitely more beautiful, restful and pleasant place to sit than any enclosed porch with a roof that can be conceived. This treatment is more Italian or English—these two foreign peoples understanding out-of-door living better than any other Europeans. It is the direct opposite of





HALL — RESIDENCE OF MRS. B. F. PEPPER, CHESTNUT HILL, PHILADELPHIA. WILLING & SIMS, ARCHITECTS.



DINING ROOM—RESIDENCE OF MRS. B. F. PEPPER, CHESTNUT HILL, PHILADELPHIA.  
Willing & Sims, Architects.

all American ideas and is an interesting departure.

The sleeping porch is also conspicuous by its absence, this, too, being a matter of personal taste.

I can imagine nothing pleasanter than actually living in the open air in what is practically a series of out-of-door rooms such as these gardens. The shelter from the wind is perfect, and yet a sunny spot can always be found if it is chilly, and on a hot, sunny day shady arbors and retreats are provided for every part of the day. And, best of all, for the winter, when the leaves are off the trees and vines, there is nothing to obstruct the sun from any window in the house.

The treatment of the planting of trees, hedges, shrubs and vines is well done and shows plainly not only a clever design in the beginning on the part of the architects, but also an insight and an appreciation on the part of the owner afterwards, as delightful as it is rare. Anyone could tell by looking at the rows of pots, with plants of every kind, standing here and there, placed on walls or

stood on the pavement, of the intimate knowledge and love of growing things in that household. Also the care with which the paving in the walled garden has been laid around the trees may well be noticed (page 357 and Frontispiece).

The roof of the half octagonal breakfast porch, opening from the dining room, is supported by fine iron lattices with a quaint, early Victorian feeling, and around the garden side of the house, above the first story windows, is a really notable and successful treatment of a lattice for vines, formed of graceful wrought-iron consoles supporting wood strips which hold the vines out from the wall, giving a delicate shade and yet adding greatly to the appearance of the house (pages 374, 376 and 377). The wood strips, of course, are the best material that could be devised for holding the stems of the vines, and the iron consoles give a beauty and interest to these lattices which is quite unusual.

Other interesting pieces of wrought-iron are seen in the balconies of both the garden and entrance sides of the house





DINING ROOM—RESIDENCE OF MRS. B. F. PEPPER, CHESTNUT HILL, PHILADELPHIA.  
Willing & Sims, Architects.

(pages 372 and 375), where, although the design is of the simplest type, the balconies count in a strongly decorative way because of the fine contrast with the background of stone.

Another general characteristic of this house which lends it great distinction is its restraint. There is not a dull part in either the exterior or the interior, and yet it is all simple to the last degree. It is seldom, even in France, in the smaller houses of the fourteenth to the seventeenth centuries, from which this house has drawn certain reminiscences, that a design is found so little labored in effect, so genuine in freshness; here is often a certain tendency to overaccentuate minor detail.

The only note in the exterior which is discordant to me is the dormer window on the garden side, with its heavy flanking obelisks and curved tympanum and consoles—a dormer that lacks the elegancies of the rest of the design, and recalls a Dutch motive.

There are certain points in the exterior which should be noted: the arches with

the surrounding lattices for vines and the fountain of the enclosed garden seen in the Frontispiece, the stone work of the walls and the circular stair tower with its pyramidal roof, and the wrought-iron half-round transom of the front door, well shown on page 373.

There is a simplicity, almost austerity, about the interiors that suits the charming old Colonial furniture, and at the same time a distinctly modern feeling about the architecture, imparting to the house the same quality that is found in contemporary sculpture, in the work of Manship or Nadelman.

The main entrance door of the house opens into a square hall of generous proportions (page 378) that is most suitably furnished. There is about the whole house a singularly harmonious effect between the furnishings and the rooms themselves. In the hall we may note an interesting treatment of the plain plaster wall surface and a cornice that is nothing more than a small cove moulding running under the ceiling. From one corner the circular stair winds to the second story.



LIVING ROOM—RESIDENCE OF MRS. B. F. PEPPER, CHESTNUT HILL PHILADELPHIA. WILLING & SIMS, ARCHITECTS.





LIVING ROOM—RESIDENCE OF MRS. B. F. PEPPER, CHESTNUT HILL, PHILADELPHIA  
 Willing & Sims, Architects.

This is certainly an attractive feature, but the effect would be better if the stairs had been made of stone or at least were all of one color. The hall is painted a light green grey, with blue green curtains at the windows and hooked rugs on the floor.

The dining room (page 379) opens directly from the hall. It is a light putty color, with grey and gold brocade curtains. The view up the few steps that separate the two rooms is charming in that simplicity which is so characteristic of the house. There is a very slight trim about the doors and the china cabinet. At the farthest end of the dining room is a niche with the minimum of wood-work set in the plaster wall (page 379). There are some lovely portraits in both dining room and hall that emphasize the eighteenth century feeling, and the beautiful china and old silver add greatly to the effect (page 380).

From the opposite side of the main

hall a door opens into the long living room (page 383), a room with windows on three sides, where the sun pours in all day long. The living room has a beamed ceiling, the narrow beams running close together and contrasting strongly with the heavy girders. There is no cornice here, and the beams rest on the rough plaster wall. The stone fireplace is set flush with the wall instead of against a chimney-breast (page 382). This is a reminiscence of the early styles and is a departure from the Georgian tradition. The bookcases cover one side of the room. The color here is delightful. The rich bindings, the brocade over the fireplace, the paintings and rugs echo their lovely reds and golds from one part of the room to another.

Altogether the house is a refreshing piece of work. It is virile and new, and stands for the best of a movement in this country that is bound to have an important effect on future work.



SOUTHWEST TOWER—OHIO STADIUM, OHIO  
STATE UNIVERSITY, COLUMBUS, OHIO.





~ The ~  
OHIO STADIUM  
AT OHIO STATE  
UNIVERSITY

JOSEPH N. BRADFORD, UNIVERSITY ARCHITECT  
HOWARD DWIGHT SMITH, DESIGNER

*By Howard Dwight Smith*

THE jubilee gift of funds for a great stadium by alumni and friends of Ohio State University, on the occasion of the semi-centennial celebration of the founding of the University, is of general interest because of the place which this new structure takes in the movement to provide housing accommodations for the nation-wide expansion of recreational activities.

The increasing recognition of the necessity for coordination of physical and mental development has not been confined to institutions of higher education. But it has been left largely to the college and the university to foster amateur athletics and to provide ideals and leadership for all sorts of recreation and

physical diversions. That these ideals have been provided and have been kept free from commercialism is sufficient evidence that the colleges and universities have been successful in the execution of their trust.

In the football season just closing there have been over 1,500 regularly scheduled games played by teams representing schools of major importance, and some 1,000 or more by the teams of the so-called secondary schools. This in itself is an indication of the widespread interest in that one branch of college athletics alone. A very conservative estimate of the number of spectators at the major games would be, say, two millions of people. There is a marked tendency

toward increased numbers of spectators each year at these major events. The ever increasing number of partisan spectators has given rise to the building of huge seating structures for the accommodation of crowds who willingly pay to see intensive contests when the reward for victory to the contestant is the mere thrill of winning and the sentiment attached to the defense of home colors.

To the casual observer these great structures do not signify their real meaning. The superficial impression of a great structure may be expressed in terms of thousands of spectators, but to the student the great structure represents the climax of his school's recreational activities, the show place for himself and for those of his fellows who happen greatly to excel in any one particular branch of athletic endeavor. The great structure at any institution is the climax of its athletic system, the acropolis of athletic inspiration, the typification of a great ideal which spurs each student on to do his best in his own recreational pursuit.

The English ideal of personal participation in athletics has found expression in more or less scorn for a mere spectator. For a long period in America, highly specialized athletics in our colleges and the development of well trained first teams, to the exclusion of the general athletic development of the student body, overlooked the great good of the English ideal. Much pedagogical criticism of athletics from within has been directed at this fault; but happily this condition has been mostly overcome. Now the "Varsity" is merely the apex of the athletic pyramid, an incentive, a goal for all athletic participation, and intercollegiate contests are but a development of intramural efforts.

#### GROWTH OF ATHLETICS AT OHIO STATE.

Conditions at Ohio State are so typical of conditions at scores of similar institutions that it might not be amiss briefly to sketch the development of athletic activities at that institution. In many institutions expansion in athletics has been greater than the general growth of the institution, not all as phenomenal as at Ohio State, but sufficient to place them

in the great general class of colleges where physical education and its attendant activities have been extended in recent years.

The administration of school lands granted by the Morrill Act of 1862 to certain States and of the funds derived therefrom has varied greatly in character. In Minnesota, for instance, the lands were mostly kept intact, and today the income from leases of ore and oil lands furnishes funds for University use. In Ohio, however, the lands were disposed of in one way or another until today the State University (under the original grant known as the "Ohio Agricultural and Mechanical College") is dependent upon a fixed levy on the tax duplicate of the State for its tuition and maintenance, upon special appropriations by the State Legislature for its buildings, and special bequests.

The significance of this condition and its bearing upon the Ohio Stadium will be apparent when two facts are pointed out. The first is that there are in Ohio some forty or fifty colleges and universities, many of much longer standing than the State University and among which the interests of the citizens of the State have been pretty well divided. The second is that all expenditures for the State University show up quickly in State taxes. So while John Smith was sending his son to Ohio Wesleyan and his daughter to Harcourt and paying well for it all, he could not be expected to bring much pressure to bear upon his representative in the State Legislature to push through appropriations for an institution in which neither he nor perhaps any of his neighbors had an interest. For years, therefore, Ohio State University dragged along slowly as an educational institution, with barely enough funds for academic existence and no subsidy for physical education or athletics. And even now, after fifty years of existence, when the University has been placed by common consent at the head of the State's education system, the use of State funds for construction of such a structure as a Stadium could not be dreamed of.

Steady growth and corresponding increase in athletic prowess during the





Plot Plan, showing proposed layout of the main portion of the campus, with the Stadium at the head of the great recreation axis, at the left. This plan includes all of the present buildings of the University proper, about forty in number.

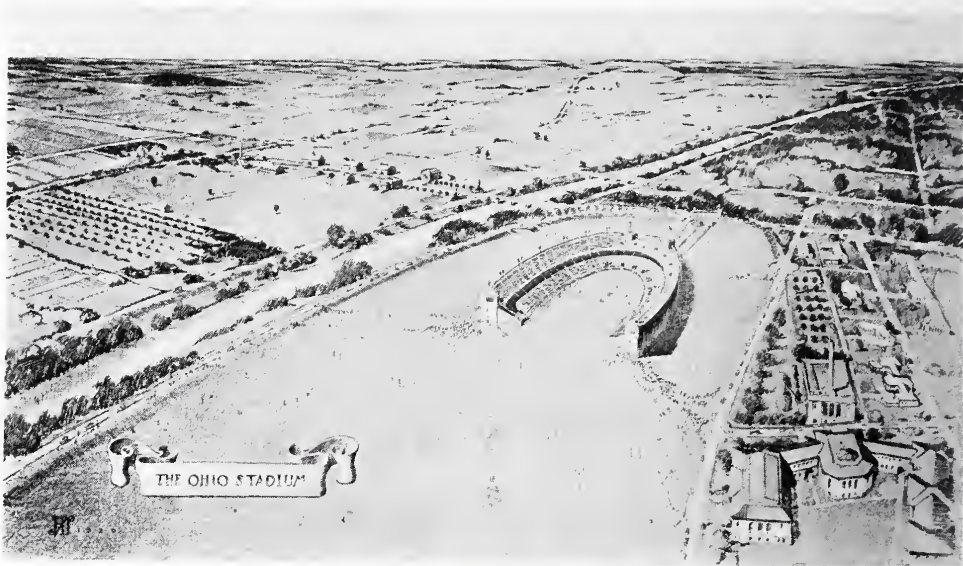

Airplane View of Recreation Field, with a small portion of the campus to the right and the Olentangy River and University farm to the left, including the projected group of buildings for the Animal Husbandry Department.

decade between 1900 and 1910 led to a certain prestige in Ohio athletics, and preëminence in the "Big Six" or Ohio Conference was fairly conceded by the end of that period. A peculiarity of athletic enthusiasm in any given institution is that it feeds on its own growth. Once its preëminence is conceded the athletic youth of the State are drawn thither, and by 1912, when Ohio State was admitted to the "Big Ten," or Western Conference,\* she had gained sufficient momentum to win the football championship of that group twice in succession (1916-1917), and to be the runner-up in a third season (1919), when she lost to Illinois in that now famous "last eight seconds."

This great enthusiasm at Ohio State, which has made possible the Ohio Stadium, has reached its crest at a time when it has benefited by the impetus of two great impulses. Athletic enthusiasm, or enthusiasm for athletics, has become very marked since the revelations made by the recent draft statistics of the surprisingly poor physical condition of many

of our nation's youth. Military training has emphasized the importance of systematic physical training as nothing else has done in recent years. The great advantage enjoyed by the college trained man, and particularly the college trained athlete, has emphasized the beneficial effect of college athletics upon physical training. The spirit of the American army is as well typified by the clean spirit of college sport as by any other one thing.

Great impetus to athletic enthusiasm has been given by the movement for so-called "mass athletics," a movement which recognizes that only insofar as every student in any institution participates in some form of athletic activity can the ideals of coordination of mental and physical development be reasonably and rationally obtained. Mass athletics has for one of its aims, for instance, that condition of affairs where each student has on his study card at least one form of competitive athletics in which he shall be graded and in which he shall attain the same degree of proficiency as is required of his academic work. Few persons know or realize that as a result of this mass athletic movement, there was conducted for an entire week last spring,

\*The "Big Ten" is composed of Michigan, Minnesota, Iowa, Purdue, Wisconsin, Chicago, North Western, Illinois, Indiana and Ohio.



without any interference with academic work, a "mass athletics" meet in the Western Conference, in which the actual scores in time, distances, etc., counted little more than did the number of contestants in the events. This mass athletics movement, taken together with intramural athletics, as, for instance, at Ohio State, where there are thirteen separate colleges within the University, indicates the universality of participation of the great body of students in recreational activities.

It has been argued that athletics in an institution should end with this "mass" participation and with intramural contests, and that intercollegiate contests of a spectacular nature are entirely superfluous. It is admitted that the greatest good for the greatest number has been derived from athletics by this participation of the rank and file. But the intercollegiate, the spectacular contest, is the logical climax which has made the entire system effective. As professional baseball without a world's series, boxing bouts without decisions, peace without victory, or a banquet with no dessert, so would be an extensive amateur athletic system without the spectacular contests of the specially trained few. And so with every well developed college or university athletic system for the past quarter of a century has come the demand for some structure to seat large numbers of spectators.

#### THE GENERAL PROBLEM.

The problem which presented itself at Ohio State is not unlike the one which presented itself to other institutions—Harvard, Princeton, Yale, Syracuse, Michigan, Wisconsin, etc. In fact, the main problem is always the same, that is, to place as large a number of seats as is possible around a field of play and to provide as nearly perfect vision of the field as possible. There are but few minor variations of this problem which may occur, and these variations depend upon whether the structure is to surround a field used for football only, or for football and track, or for football, track and baseball.

At Ohio State, as elsewhere, the matter

of providing more seating space was a business proposition with the Athletic Board. But because of the close relationship between athletics and physical education, the Athletic Board realized the necessity of providing a structure which could be used for the greatest number of purposes. The administration and financial management of intramural and intercollegiate athletics is vested in the Athletic Board, appointed jointly by the Trustees, the President and the Alumni Association. The executive is the Director of Athletics, who is also the head of the academic department of Physical Education with the rank of professor. This arrangement has proven a very satisfactory point of contact, which unfortunately does not always exist between academic and athletic interests in all institutions of higher education.

With this community of interest, therefore, the Athletic Board approached the problem of providing a structure which would best satisfy all the needs of the University. The problem at once divided itself into its fundamental three parts as in the case of other institutions. The first, the plan and seating arrangement, to provide the proper field space, and the maximum income for minimum expenditure; the second, the appearance of the structure and its relation to other structures, or groups existing or proposed; the third, structural expediency and stability.

#### LOCATION AND ACCESSIBILITY.

As the facts of the case now show, the Athletic Board considered size and shape of much greater importance than location, and their first efforts were spent in determining how large a structure could be built and what shape would be most advantageous. The matter of location, by order of the Board of Trustees, however, placed the problem directly in the hands of the University architect, charged with campus development. The problem then became one of joint study, always with relation to the general scheme of campus improvement as well as of athletic needs.

Fortunately, Ohio's campus, now of nearly 900 acres, is all contiguous—for



RENDERED PLAN—OHIO STADIUM, OHIO  
 STATE UNIVERSITY, COLUMBUS, OHIO.



the most part, except the portion used for farm purposes, within the city limits—and in spite of the present more or less informal location of buildings of diverse style, the possibilities of group planning are quite wonderful. Fortunately, also, the problem of the location of the Stadium was given to one who is responsible for the aspect of the 900 acres, for it was upon his drastic recommendation that some ninety-two acres of fertile bottom land was appropriated from the College of Agriculture and given to the Department of Physical Education and the Department of Military Science.

In the recent studies for campus development the group, or axial, plan has been used, superseding the informal unit plan. This scheme was followed in recommending a location for the Stadium. It is placed on a new and important axis, now known as the recreation field—groups on other axes being the academic, engineering, agricultural, medical, dormitory, etc. This location is far enough removed from the existing buildings of the University to avoid conflict of scale. The area covered by the enclosure of the Stadium walls is as great as any ten buildings on the campus, and its height is over twice as great as the average height of the fifty other structures on the campus. The fact that the general level of the bottom land is about 25 feet below the average level of the main part of the campus is not to be overlooked in this connection. The accessibility of the new location from the campus, however, avoids the difficulty experienced in many institutions where athletic plants are not contiguous to the main portion of the campus.

The location of the Stadium on the new recreational axis carries with it several other interesting features. The straightening of the Olentangy River bed and the control of its flow between levees provide a boulevard and terrace along the west side of the ninety-two acre plot, which is to be reclaimed on the east by a similar boulevard and terrace. The Stadium, therefore, occupies a focal position in this somewhat irregular ellipse, at the head of the axis on a practically level field, which is devoted to athletics and all

recreational activities, infantry drill, artillery practice and aviation.

It should be mentioned in passing that the question of external circulation was one of the early considerations in the problem of location. The gathering of a crowd of 60,000 people presents no small problem as regards approach, parking and retreat. The boulevard around the entire field is of particular advantage. There are two main avenues of approach through the main part of the campus and five roads of approach and retreat outside the campus, with provision for a private car track loop connecting with the city lines, with sufficient trackage to hold in reserve enough rolling stock to carry a third of the capacity of the Stadium itself.

#### FEATURES OF THE PLAN.

There are three principal features in the design of the Ohio Stadium which distinguish it from other structures of its class. These are (1) the double deck, (2) the "bowed" or curved sides with an open end, and (3) the extensive use of the space under the lower deck. All of these features grow out of the desire on the part of the designers to satisfy certain definite parts of the problem as presented by the Athletic Board and studied by them in conjunction with the University architect. These features, as well as all other details of the structure, have been studied in the light of precedent, both architectural and structural, not only of ancient buildings of similar nature, but particularly of contemporary structures. All of the important stadia and amphitheatres used for athletic purposes have been quite fully described in technical magazines from time to time, and all data with reference to them are readily available for study. This study has been amplified by inspection and by interviews with persons who are now interested in their care and management, in order to determine just wherein these contemporary structures have been successful and wherein they have failed or might be improved upon. A report of these inspections appeared in *The American Architect* for July and August, 1920. In the light of lessons learned from all

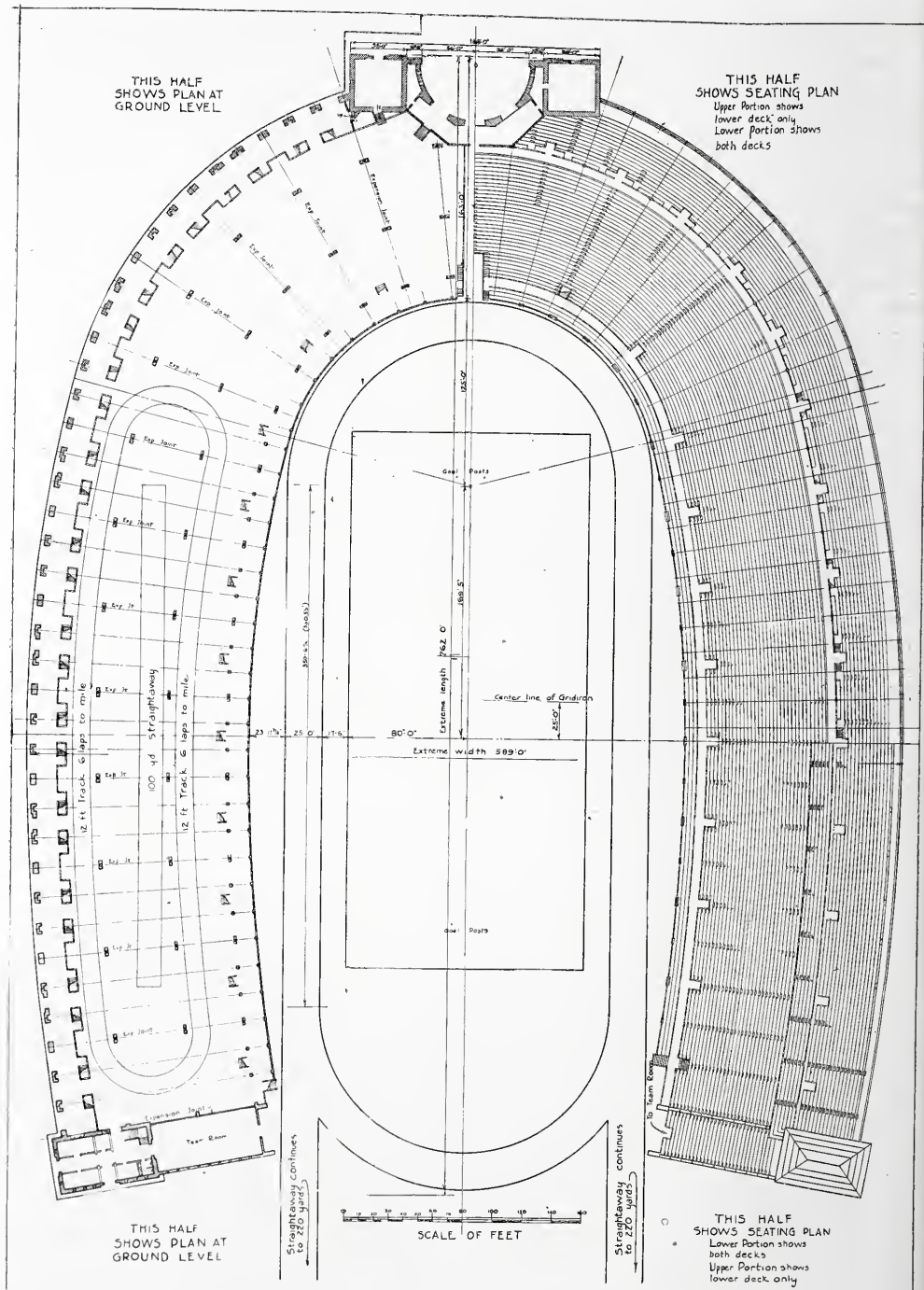

DIAGRAM SHOWING STRUCTURAL SYSTEM AND SEATING ARRANGEMENT—OHIO STADIUM, OHIO STATE UNIVERSITY, COLUMBUS, OHIO.



sources, it is thought that, for the present at least, the Ohio Stadium represents a satisfactory solution of the University and community seating problem for outdoor events. Of the three features mentioned above, the double deck is perhaps the most distinctive. It presents several intricate problems of plan, circulation, appearance and structural stability which have made it a hard proposition to solve. Before discussing this feature it will be more logical, however, to consider the plan arrangement which involves the second of the distinguishing features, the "bowed" side with the open end.

#### OPEN AND CLOSED TYPES OF STADIA.

Of preceding structures, both ancient and modern, there are two types: one (of which the Harvard Stadium is a modern example and the Roman Circus Maximus a classic example) has straight sides and an open end; the other (of which the Yale Bowl and the Roman Coliseum are typical) is entirely closed with all seat lines curved in plan. There are certain features of both types which are of advantage for staging modern athletic events, and there are other features of each type which experience has shown to be of decided disadvantage.

Aside from imperfectly designed details and imperfections of execution the advantages and disadvantages of the two types may be briefly stated. In favor of the straight-sided, open-end type they are (1) that it can be conveniently built around a quarter mile running track with "straightaways" for dashes; (2) simplicity of construction; (3) it lends itself easily to good architectural composition, and (4) the open end gives proper ventilation. The faults to be found in the straight-sided structure are not very serious, but the chief ones may be enumerated as follows: (1) great inequality of seat values; (2) loss of the "crowd psychology," and (3) tendency to expense and disfigurement in placing temporary seats at the open end to increase capacity. In favor of the closed or amphitheatre type are two very strong points: (1) beneficial effect of "crowd psychology" in a structure where every

spectator is sensible of the presence of nearly every other spectator, and (2) approximate uniformity of seat value. A third virtue might be noted in the possibility of unity and simplicity of architectural composition. Opposed to these virtues, the closed type, particularly those with curved sides, presents these drawbacks: (1) a quarter-mile track cannot be placed within the structure unless the first seats are at a very great distance from the football gridiron; (2) no straightaway track for dashes; (3) poor ventilation, particularly at the level of the playing field, and (4) expensive construction involved in building all seat lines to curved plan.

If nothing were to be considered but football, there is no question but that the closed bowl type is much to be preferred. The Yale Bowl presents ideal conditions for football. By ignoring all consideration of other sports, particularly track, it has been possible to construct an elliptical tier of seats, the inside row of which is very close to the gridiron. The method of determining the size of this ellipse was a simple one. The athletic authorities determined just how close to the four corners of the gridiron the seats could be placed for convenience and safety to players. Through these four points the inner perimeter of the seat tier was described.

The method of determining size at Harvard consisted in fixing the minimum distance for convenience and safety between gridiron and cinder track, and the minimum width of track. These dimensions added to the width of the gridiron have determined the diameter of the curved or closed end. This makes the average distance of the first row of seats from the gridiron somewhat greater than is the case at the Yale Bowl. At the open end of the Harvard Stadium the track is completed, extending out just far enough to make the entire length a quarter mile. It should be remembered that no record events on the track can be run on less than a quarter mile. These details of the Harvard and Yale structures are dealt with at some length because of their influence on the plan adopted for the Ohio Stadium.

## THE OHIO PLAN.

With a view to combining the advantages of both types, as outlined above, and avoiding as far as possible their disadvantages, the Ohio plan was adopted. The curve on the sides has been made as great as is considered practical without making the middle seat sections appear too far away from the gridiron. This curve is calculated to give all the advantages of the "crowd psychology," which is a very attractive feature of the Yale Bowl. An added advantage of the "bowed" side is the equalizing of seat values. It has been found that in the case of the Harvard Stadium the seats opposite the middle of the gridiron on each side are considered far superior to those opposite the ends of the gridiron. The pushing back of the center sections has a tendency to make the seats toward the ends of the playing field relatively more desirable than they would otherwise be. This, of course, reduces the difficulties attendant upon the sale of seats.

The width of the track being determined at 25 feet to accommodate six 4-foot lanes (reduced to  $22\frac{1}{2}$  feet on the curves) and a minimum space of  $17\frac{1}{2}$  feet being established between track and gridiron sideline, the diameter of the inner wall of the closed end of the Ohio Stadium becomes automatically fixed at 250 feet. By methods of "cut and try," it has been determined that the depth of the "bow" on each side should not exceed  $24\frac{1}{2}$  feet.

The entire length of the structure is 760 feet, determined largely by the required seating capacity, fixed by the Athletic Board at approximately 60,000, and the maximum distance deemed desirable for good view of the playing field. In plan the gridiron is not placed with its middle line on the cross axis of the Stadium or the track, but is moved up 25 feet toward the closed end in order to equalize the seating value of the extreme ends of the wings and the circular portion. The distance from the actual center of the gridiron to the farthest seat at the circular end is 420 feet and at the two end towers is 390 feet. By way of compari-

son it is noted that the distance from the actual center of the gridiron to the nearest box seat is 150 feet, and to the topmost seat on the upper deck directly opposite the middle of the gridiron is 286 feet.

Compare these figures with the following corresponding ones at Harvard and Yale. At Harvard the nearest box seat to the center of the gridiron (temporary boxes built out over the cinder track) is 87 feet and the uppermost seat on the same line is 205 feet from the center; the farthest seat at the closed end is 400 feet from the actual center of the playing field. At Yale the nearest seat is 152 feet from the center of the ellipse and the topmost seat on the cross axis is 375 feet away, while the topmost seat on the long axis is 475 feet from the actual center of the field.

## OTHER TYPES OF MODERN PLANS.

It is interesting to note that Syracuse has attempted to combine the good features of both the open and the closed type by using straight sides and two closed ends, building the structure around a regulation quarter-mile track. This has been fairly successful, except in the location of a straightaway for dashes. The 220 yard straightaway has been provided by running a tunnel through one end of the enclosure on a line with one of the straight sides of the track. It has been noticed that runners are at a decided disadvantage in running on tracks of this kind, because of variations in temperature and atmospheric conditions in the tunnel and the invariable outward draft, due to difference in temperature on the inside and outside of the Stadium. Even when atmospheric conditions are nearly uniform inside and outside of the tunnel, the mental hazard handicaps the runner who is unaccustomed to running under such peculiar conditions.

It is also interesting to state that at the University of Washington, where it is proposed to build a large new Stadium, the architect, Mr. Carl F. Gould, and the engineers associated with him, without conference with the designers of the Ohio Stadium, but by strikingly similar lines



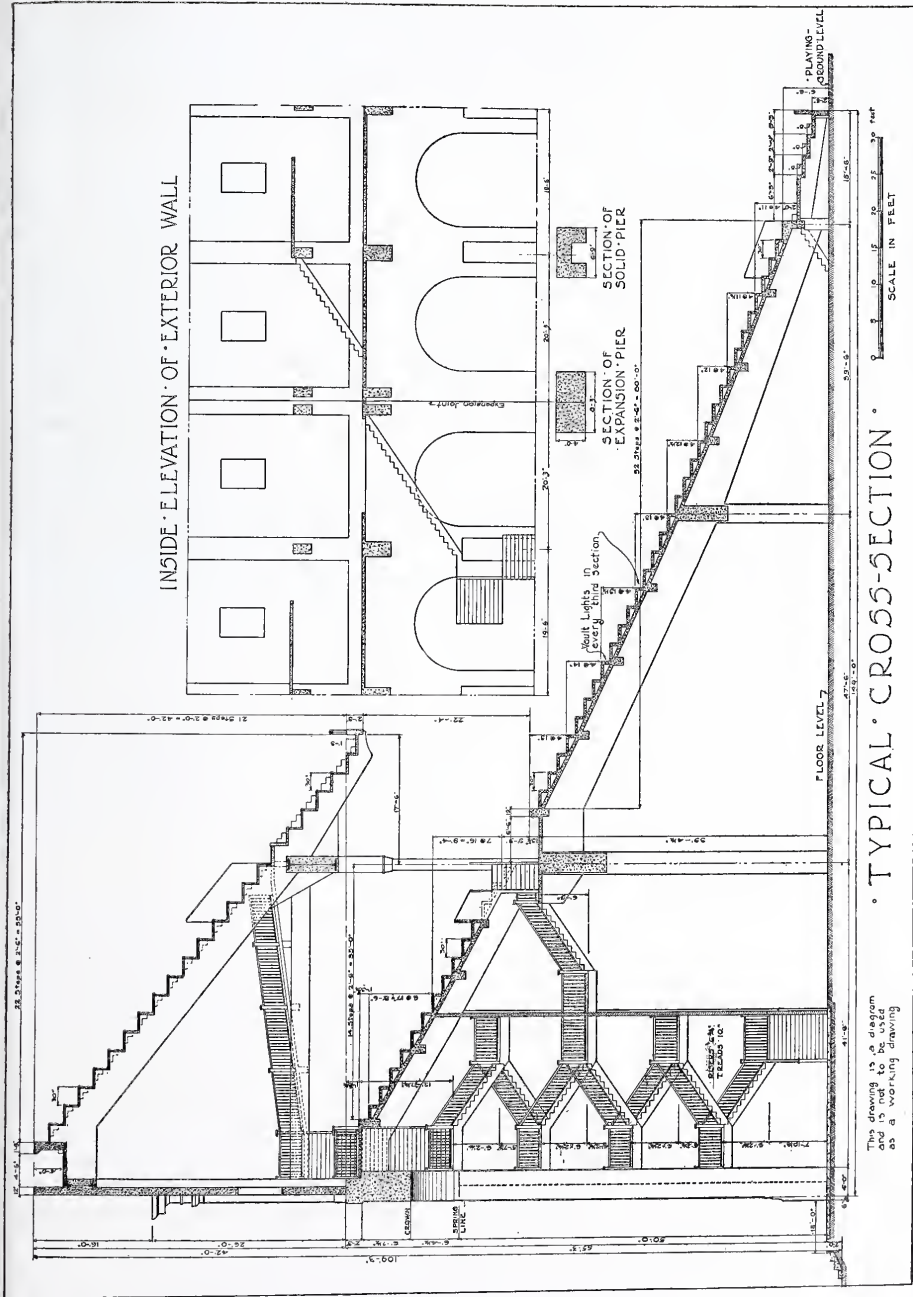

DETAIL CROSS SECTION — OHIO STADIUM,  
OHIO STATE UNIVERSITY, COLUMBUS, OHIO.

of study, have arrived at a very similar "bow-sided" plan, with a somewhat similar cross section and sight line, although all other details are quite dissimilar.

The proposed Stadium for the city of Chicago, designed as a recreational civic center for the municipality, is to be a straight sided, open end structure, but of such huge dimensions, particularly as to length, that of its potential seating capacity of 100,000 not more than 25,000 or 30,000 seats can be conveniently arranged about a football gridiron. The architectural success of the attenuated plan in this instance, however, is assured.

THE CROSS SECTION.

To any one studying Stadium design the cross section tells the most interesting story. The cross section determines the ease and convenience of circulation, the convenience of sight and the sitting convenience of the spectators. The cross section of the Ohio Stadium is particularly interesting, because it shows the details of the upper deck feature.

Of the dozen or so large stadia and amphitheatres in this country, the one detail in common which is most easily compared is the relationship between the rise and tread of the seating section. The principal ones are tabulated as follows:

Name.	Tread, in.	Rise, in.
Harvard .....	27	15
Princeton .....	30	15 to 17
College City N. Y.....	28	16
Yale .....	30	8 to 12
Syracuse .....	27	18
Michigan .....	24½	9 to 12½
Tacoma .....	27	18
San Diego .....	30	17
Chicago (proposed)...	30 approx.	8 to 12
Ohio State (low. deck).	30	11 to 17
Ohio State (up. deck).	30	24

It is generally conceded that Harvard's 27-inch tread is a little too narrow, and that the 30-inch tread at Yale and Princeton is practically perfect for seating comfort.

Variation in the riser to provide a clear sight line for the lower seats has been determined in the Ohio Stadium by assuming for each row a clearance of four inches over the average head line of the row immediately below it. The sight line is assumed so that spectators in the seats

on the long axis at the curved end will be able to see the goal line at the far end of the field. This assumption, of course, makes the average sight line along the sides more favorable. For convenience in building the risers vary in blocks of four for the bottom two-thirds of the lower deck. The sight line is also so arranged that the spectators in the lower rows may see the middle line of the cinder track. The location of the lower edge of the upper deck has been determined by assuming a sight line on the long axis for a person standing at the outside wall and being able to see the goal line at the opposite end of the gridiron.

The proper disposition of boxes is also a matter to be determined on the cross section. For actual seeing value only those boxes near the center of the field are of much worth, but the usual demand for box seats in any location for social purposes is one which it is profitable to meet, provided it can be done without interference to other seating. In the Ohio Stadium three rows of steps are devoted to boxes, with the top row placed on the same level as the principal bottom horizontal circulation just above the level of the playing field. The total capacity of the box space is approximately 1,700.

CIRCULATION AND CONTROL.

Circulation within the structure involves two principal considerations. The first is that of convenient distribution of the spectators as they assemble and the rapid and safe dispersal as they leave. The second is the matter of control and ticket taking. Chiefly for architectural composition, and not for the concentration of assembling crowds, has the entrance feature at the circular end been emphasized. As a matter of fact, it is recognized that the best results in handling assembling crowds are obtained by selling tickets at isolated points away from the structure and by effecting the greatest possible distribution outside of the structure itself, and that the route from entrance to seat be as short and direct as possible. This is a problem both of plan and of cross section. The location of "eyes" or portals is a matter of cross



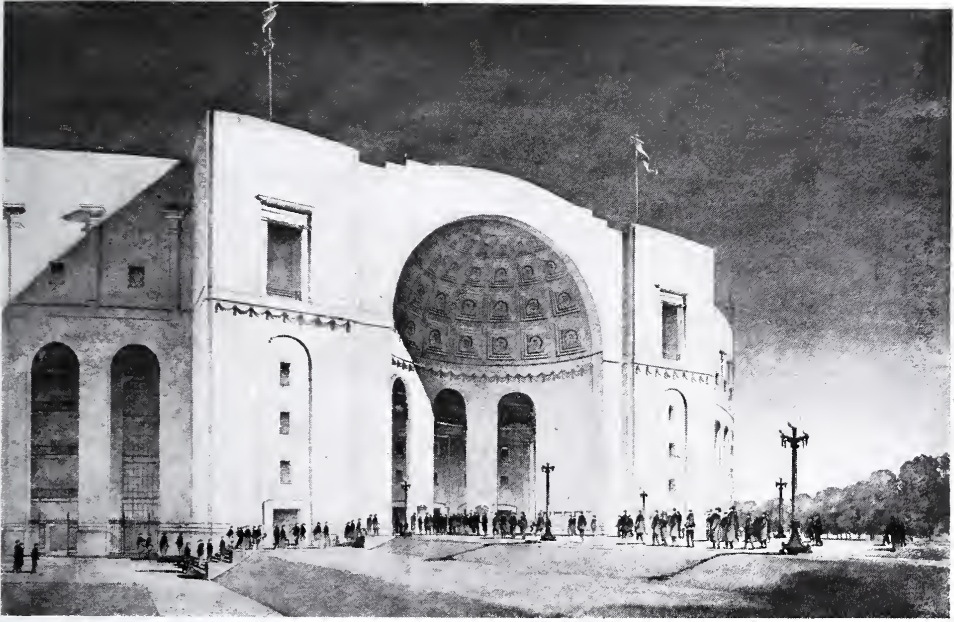

NORTH ENTRANCE—OHIO STADIUM, OHIO STATE UNIVERSITY, COLUMBUS, OHIO.

section. At Yale and at Princeton the portals are located at the midway point of the cross section. The spectators are delivered to these portals by ramps and are allowed to distribute themselves up and down from the midway point. This system has proven very satisfactory in practice. In both cases admission tickets are taken at two isolated points in an enclosing fence at some distance from the structure, and reserved seat stubs indicate the proper entrance portal.

At Harvard the cross section shows two rows of "eyes" or portals, dividing the cross section into three parts. The upper row of portals is fed by four great staircases and a distributing promenade. This system proved quite effective in emptying the seats rapidly, but experience has shown that rapid emptying of the Harvard is not altogether desirable because of the excessive congestion that occurs at the Larz Anderson Bridge over the Charles River, across which practically the entire crowd must circulate. In recent years, therefore, the upper row of portals has been closed with temporary seats for major games, increasing the

seating capacity by about 550 and not interfering with the control or distribution of the spectators.

In those structures where topographic conditions permit the entry of spectators from an outside level above the playing field, as at Yale, Princeton, and the proposed Seattle Stadium, the problem of vertical circulation is comparatively simple. But in the Ohio Stadium, as at Harvard, where the ground level is very close to the water level of the adjoining river, the entire crowd must be elevated to the seating tiers by means of vertical circulation.

The accompanying diagram shows the circulation system as finally developed for the Ohio Stadium. Portals are provided at the rear of the boxes just above the level of the playing field, at the promenade line two-thirds of the way up and in the upper deck one-third of the way up from the bottom. Around the entire structure is a circulating corridor, which can be entered through any arch in the exterior wall. Directly opposite each exterior arch opening there is an opening in the inner screen wall of this circulating



Exterior Elevation of a south tower and a portion of the adjoining wall according to the final scheme of continuous, open and exposed expansion joints.

corridor, which leads directly to one seating section. The diagram indicates by various kinds of lines the line of travel from this corridor to each of the portals in the seating tiers. Every third opening leads directly across the structure on the ground level to the lower row of portals by which the boxes and the bottom half of the lower deck are served. All other openings lead directly to stairs which end in ramps leading to the upper portals. These stairs are arranged in pairs in such a way that cross circulation may be prevented entirely. By this system all confusion in ushering spectators is avoided by proper guidance and control at the ground level. By appropriate marking of the arches on the exterior wall it is possible to make almost perfect distribution of any large crowd as it assembles.

The extreme flexibility of this scheme of circulation, as indicated by the diagram, will be apparent from even a casual inspection. Spectators may be admitted

to the circulating corridor through any number of exterior arches, allowing secondary distribution in the corridor itself. By the simple expedient of opening the gates of the exterior arches into and across the corridor it is possible to control each seating section at the exterior wall. The possible combinations of control are thus practically unlimited and can be arranged and rearranged almost instantly, according to the size and intensity of the crowd to be handled. The success of the double-deck venture is largely dependent upon the convenience of that part of the vertical system which serves it.

#### THE DOUBLE DECK.

The chief reason for the use of a double deck is to provide a larger proportion of the entire seating capacity near the playing field than is possible with a single deck. From the cross-section it will be noticed that the upper deck is hardly more or less than an upper section of a single deck moved forward until



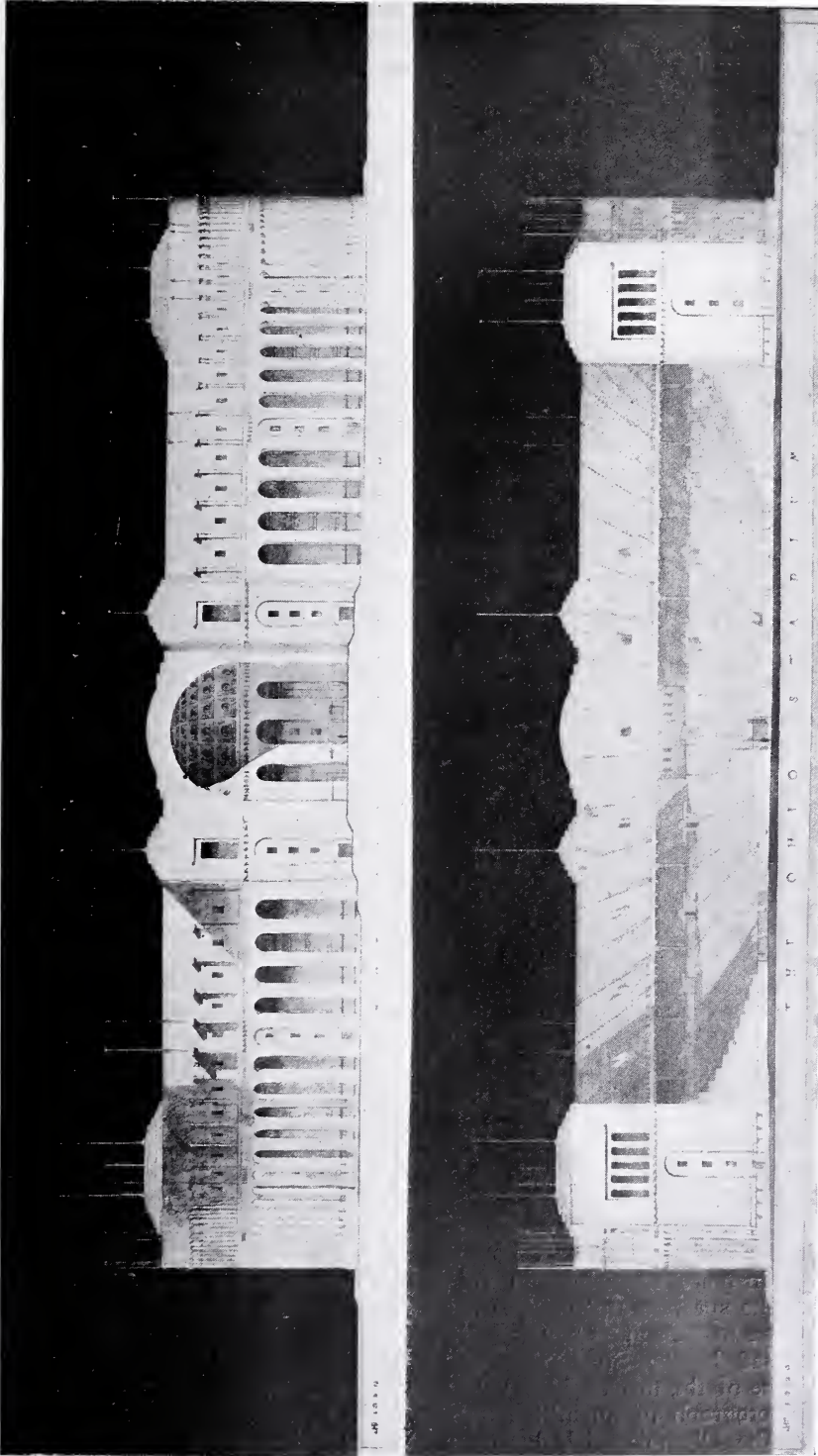

Above: North Elevation. In this rendering the original scheme of expansion joints concealed behind pilasters is shown. Below: South Elevation, looking into the "horseshoe."

it overlaps the lower sections. These seats are therefore placed just that much nearer the playing field. This device presents two new problems which are not found in a single deck. They are (1) the structural problem of isolated supports to interfere least with sight lines, and (2) difficulties of architectural composition. The athletic authorities are agreed that the increased value of seating space near the playing field, as well as the very great advantage of roof protection thus afforded to a portion of the lower deck seats, is worth the study and expense necessary to produce satisfactory results. The question of sight lines has been discussed before and also that of shutting off the view of the rear seats of the lower deck.

The support of the upper deck is affected by a series of posts located along the line of horizontal circulation two-thirds of the way up the lower deck. These columns are approximately sixty feet apart (three bays on the line of the exterior wall measure sixty feet) and are doubled in order to provide separate support for each structural section of the Stadium. These columns support girders about seven feet deep, over which the lower fourth of the upper deck is cantilevered. Structural stability is secured by horizontal braces from the column tops to the outside wall and by knee bracing in the three other directions.

The arrangement of columns is such that lines drawn from gridiron goal posts, past the columns along the two sides of the structure show that there is a large triangle of seats between each two posts extending back to the outside wall, where the view of the gridiron is entirely unimpeded.

The protection which this upper deck affords over a portion of the lower deck is of considerable importance. The spectators at early fall games experience some inconvenience due to warm temperatures, but in many instances at spring and summer games the spectators actually suffer from exposure to the sun. Only recently there appeared in the Sunday graphic section of one of the metropolitan newspapers a photograph of an athlete performing in the Olympic trials before a

"sweltering crowd of 22,000 people." The upper deck of the west wing of the Ohio Stadium will shade approximately 12,000 seats by the middle of the afternoon in summer. The roof value in inclement weather is of some importance, but this is not a prime consideration.

The engineering problems involved in the upper deck scheme may be solved by sufficient ingenuity and the proper expediture of funds. The architectural problem involved is not so easy of solution. The great overhang of the cantilevered portion and the great distance between supports create a condition which no architect relishes. The elimination of a closely spaced colonnade deprives the designer of a graceful and powerful architectural device for depicting scale. The apparent weight and massiveness of an upper deck of masonry, carried on few partially concealed supports, create an anachronism to the eye of a profession trained in the proportions of stone masonry. This seeming structural paradox can only be overcome by logical expression of reinforced concrete forms, designed and executed in the same good taste and reasonable proportion as is required of stone masonry.

#### ARCHITECTURAL CHARACTER.

Properly to express the ideals for which it is built and influenced by all the ties of sentiment and historic precedent, the Ohio Stadium follows the example of most of its contemporaries and depends upon monumental simplicity and classic severity for its architectural character. While the double deck determines very largely the architectural composition of the structure, the expression of monumental character in the use of an upper deck is a new and untried thing. There are examples of double-deck stadia, notably those of professional baseball, such as the Polo Grounds in New York, but in no instance has there been any pretense to monumental character. Indeed, in all such cases there is a decided theatrical character which it is desirable to avoid in these collegiate structures.

The horizontal subdivision made by the wide flat band on the exterior wall sug-



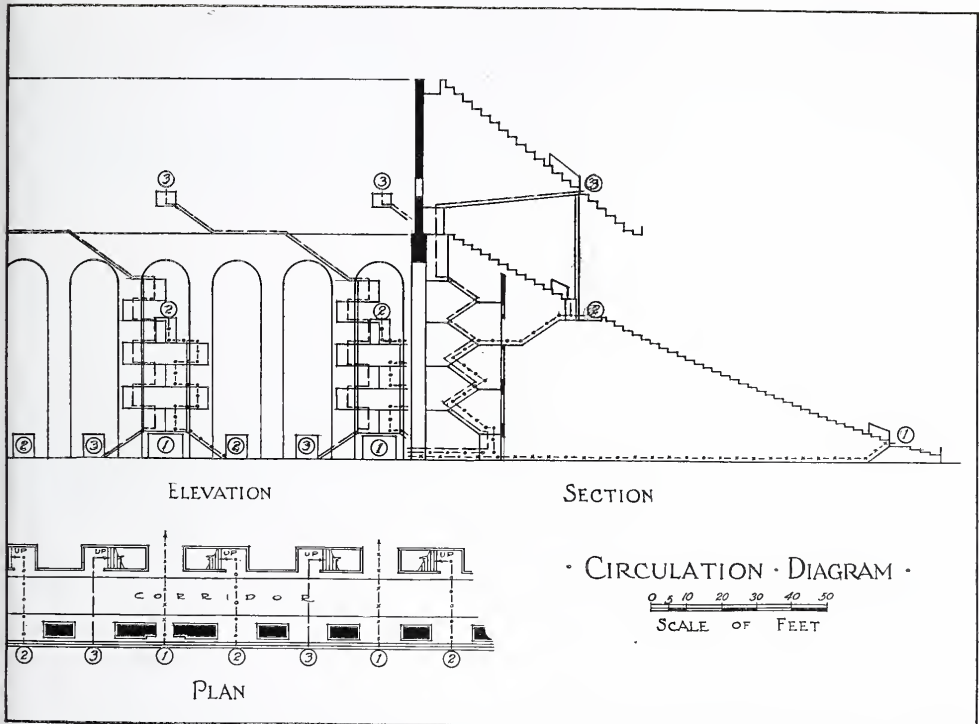
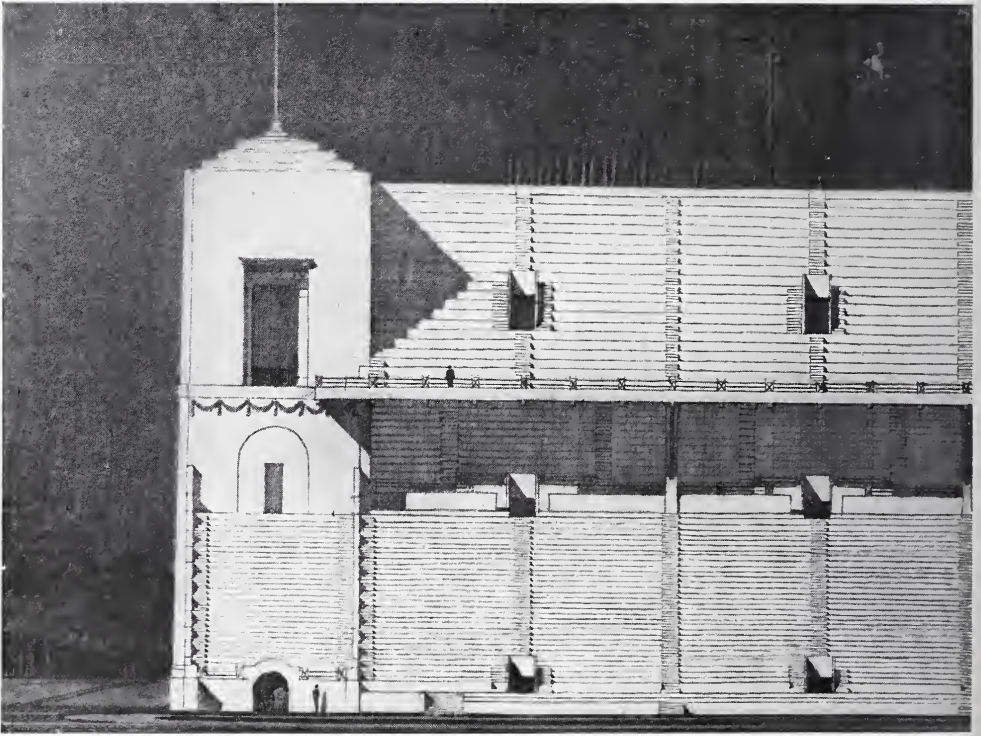

Diagram of the circulation system, showing method of control along outside corridor.

gests the top of the lower deck. This band has been carried around on the inside and is made to coincide exactly with the concrete beam which forms the lower fascia of the upper deck. This fascia, twenty-seven inches deep, extends around the curve over 1,500 feet in length from tower to tower, and is relieved of the apparent incongruity of being an attenuated beam by the regularly expressed ends of the concrete rafters which support it at intervals of approximately eight feet.

Externally the principal feature is the great semi-circular entrance at the closed end, with its coffered semi-dome. The arch over this entrance is one hundred feet high and seventy-two feet in diameter and suggests the character of the great niches of the Roman baths. The coffered ceiling also suggests the very well-known example in the Roman Pantheon. The continuity of stilted arches along the lower portion of the exterior wall suggest, perhaps only remotely, the composition of the Roman aqueducts and bridges. The

screen wall of the upper deck, with its small, square windows and its engaged pilasters, partakes somewhat of the character of the top story of the Coliseum. Thus the exterior is fairly well connected with accepted classic tradition. The use of these classic forms, however, does not detract from the novel composition suggested by the south elevation and the interior views. The impression created is that the structure consists of a long two-storied horseshoe, terminating in towers at each end, and that in front of this structure has been placed an inner tier of seats extending down to the ground level. This is especially emphasized by the design of the end features, where the tiers of seats have been set between stepped wing walls placed symmetrically about the axis of the tower. The arched entrance to the team quarters forms an interesting spot in the composition of the end feature. The treatment of the end motives has been designed to avoid the apparent bareness and incompleteness



Interior Elevation of a south tower, a portion of the seat tiers, and the entrance to the team room.

felt in the end walls of the Harvard and the Princeton stadia.

The entrance feature is emphasized but little on the interior. The seats of the upper deck pass right over the semi-dome. The irregular shaped space between the semi-circular entrance and the line of columns supporting the upper deck is taken up with rest rooms and space for motion picture projectors, spot lights, etc.

All moulding profiles are susceptible of being worked in concrete. Relief from monotony of color and surface is afforded by the inlaying of terra cotta ornament in the form of a festoon band on the towers around the semi-dome, and over each of the blind arches of the exterior wall. These blind arches are introduced to relieve the monotony of the continuous arcade and to give expression to the vertical circulation of the upper deck. The entablature of the enclosed order in the towers is of colored terra cotta. The engaged pilasters on the up-

per screen wall represent points of reinforcement in that wall and are of the same Tuscan order as the enclosed order of the towers. The embellishment on the curved walls of the front entrance consists of a wainscot of bronze panels, upon which are found the names of the founders, patrons, donors and subscribers whose generosity has made the Stadium a possibility.

For surface treatment of the concrete, the Ohio Stadium follows the frank expression of material found in the Harvard Stadium, which after seventeen years of wear has proven very successful. The interesting texture given to the great flat areas of concrete by the form marks may not have been entirely intentional. The effect, for instance, of the markings from horizontal planks placed at regular intervals in sections of vertical planks in the end towers of the Harvard structure is as interesting in composition and proportion as it is in the frankness of mate-



rial expression. The possibilities of this economical method of obtaining interesting surface texture are also suggested by the results obtained at the Army Supply Base in Brooklyn by Mr. Cass Gilbert, where no extra surface treatment has been resorted to to eradicate the form markings or even the marks left by the wire cross bracings. Surface tooling, which was begun on the Harvard Stadium but abandoned because of its expense, is used to great advantage in giving a finishing touch around mouldings and openings.

### STRUCTURAL SYSTEM.

The acceptance of concrete, both plain and reinforced, as the most effective material for large operations both for economy and facility of construction has presented new problems for the designer as well as for the engineer. The science of concrete slab and beam construction has been as standardized as that of the rolled steel section. For the engineer, however, the two great problems involved in concrete construction of great size are first the necessary inspection to insure laboratory perfection of execution, and second the location and design of expansion joints. The first only affects the architectural designer insofar as it should influence him in avoiding the creation of intricate or impossible conditions.

The problem of expansion joints, however, has come to be as important for the architectural designer as for the structural engineer. Experience of the past decade has proven that in large operations it is impractical to conceal expansion joints. Experience also shows that simple butt joints in single planes are most effective and present the least difficulties in maintenance.

Consequently, the structural system employed in the design of the Ohio Stadium is that of building integral sections consisting of three bays each, which measure sixty feet along the face of the outside wall. The central portion of the main entrance forms a structural unit. Each of the towers on either side of the entrance arch and the two at the south ends of the structure also form separate

units. Thus the Stadium consists of thirty-four separate and distinct units which have nothing in common except footings. Pier dimensions and arch spans in the exterior wall have been so proportioned as to accommodate the joints between adjoining units without any overlapping or slip joints. The vertical supports at these expansion joints are all doubled so that girders and beams of each section may be supported entirely by elements of the units in which they occur. This is an amplification of the successful system used in the substructure of the Harvard Stadium, where girders of each section bear upon piers located about three feet from each end, with the girders of adjoining sections butting together leaving a 6-foot space between the adjacent columns.

The only extraordinary features of structural design involved are the heavy girders spanning the 60-foot space between the columns which support the upper deck, and the design of these coupled columns to make them as thin as possible in order to obstruct as little as possible the view of the playing field from the seats in the upper portion of the lower deck.

The upper deck is constructed largely of steel, much after the scheme of the entire Harvard Stadium. Precast seats in short lengths are used, and the steel work is protected with cement. The entire lower deck is constructed as a sloping roof slab, in order to form proper protection to the space below. On this roof slab are placed precast seat sections, in short lengths, resting on lugs cast in the sloping slab. A system of seat drainage is provided, with catch basins at numerous intervals throughout the cross section in order to prevent the weathering effect of water washing down over great areas of seats. Gutters are provided under expansion joints, to take care of the unavoidable leakage at those points. The stairways of the vertical circulation system are of firescape construction. The footings for the entire structure rest on the gravel of the former bed of the Olen-tangy River, which now flows to the west of the entire recreation field.

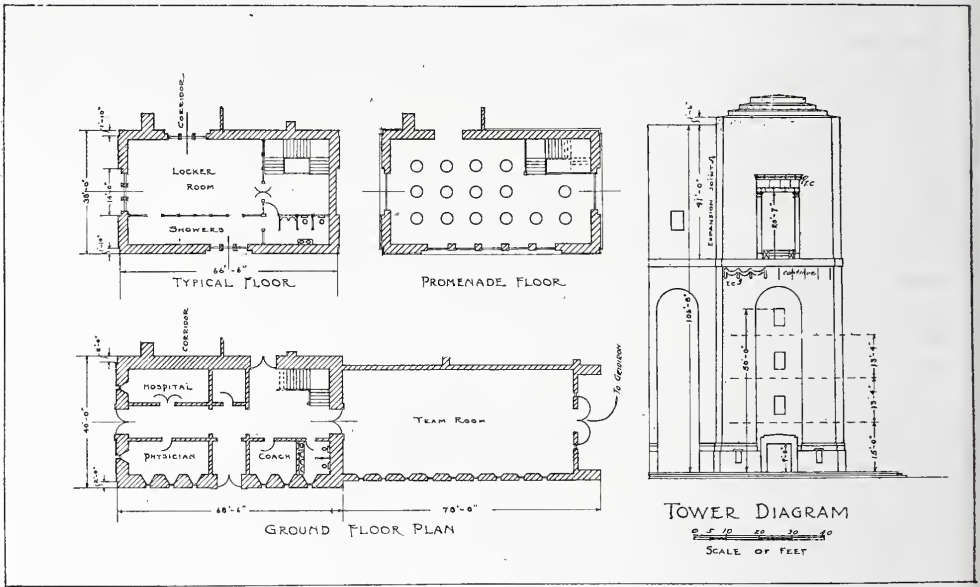

Diagram Elevation and Floor Plans of the south towers, showing their use for housing a portion of the recreational accessories.

#### UTILITARIAN FEATURES.

When the South Side Park Commission undertook to conduct a competition for the choice of an architect and a scheme for the Municipal Stadium for the City of Chicago, one of the requirements of their program was that the space under the seats of the amphitheater be put to some use besides mere circulation.

To attract the support of a great variety of business and civic interests, the inclusion of such a feature in the Stadium project was a valuable one. That feature received a great deal of attention from the competitors and several interesting and practical ideas were developed. The availability of the open arena itself for civic events, pageants, dramatics and other things besides athletic activities has not been minimized, but that particular use of such structures has always been more or less accepted.

In the new Ohio Stadium the capacity of the semi-circular end of the structure is nearly 20,000 on account of the double-deck feature. Convenient use is made of the irregular shaped spaces between the curved walls of the great entrance and the straight walls facing the interior of

the arena on the various levels for housing projection booths and spotlight apparatus, as well as ticket offices, dressing and retiring rooms. With a removable stage across the upper end of the arena unlimited possibilities are suggested for the use of the Stadium. But such extensive use of the space under the seats, as suggested by the Chicago project, is new, if not in idea, certainly in execution in this country. The fact that the space is there, and is available if properly disposed and finished, is sufficient reason for trying to extend the use of the capital invested in the structure as far as possible.

Few large college stadia make any use of the space beneath their seats for any purpose except for storing the caretaker's tools or some such comparatively insignificant use. At Yale, of course, there is no available space, all the seats resting directly upon earth. At the City College there are showers and stairs in the towers. At Princeton there is a little storage space. At Harvard there is a track under the outside corridor, but it is not continuous. The structural system at Harvard, with small precast seat sections resting directly on steel supports,



leaves a great many interstices which are not weatherproof. Many who have been at the Harvard Stadium testify to the fact that the stands "leak like a sieve." While it would be well if the space under the stands were available for track or training purposes, still the existing condition is evidence of one of the secrets of the present excellent structural condition of the Harvard plant. Natural expansion and contraction of the concrete is taken up in the small seat units and no attempt is made to keep the interstices between them cemented up.

The need of space for training quarters, for team rooms, and the like, at Ohio State, and the possibility of greater appeal to the friends of the University who have so generously supported it have led to the development of the scheme for using all the available space under the stands for some purpose or other, giving the greatest return for the investment in the structure.

Since ample stairways have been provided around the entire structure, the end towers are not needed for extensive vertical circulation. They have, therefore, been given over entirely to team rooms, showers and lockers. Economy and convenience of maintenance have made it advisable to keep the small rooms and those quarters requiring mechanical equipment, such as plumbing and heating, arranged in the tower units. The main power plant of the University is located only about a thousand feet from the southeast tower. The plans are arranged so that for football, for instance, the Varsity will use one tower and the Freshmen the other, and for intercollegiate contests the visiting team will use the Freshmen quarters. Entrances from these quarters to the field are by the low arches on the axis of the end section of seats at the towers.

The space under the seats, however, is made available for use by the roof slab covering over it and by the judicious arrangement of columns in it to allow as much free space as possible. The inside screen wall of the great circulating corridor around the entire Stadium is mostly of glass, in metal sash, such as are used for factory work. This, together with

vault lights in every third seating section, gives light into this inside space. The placing of all vertical circulation along this outside corridor frees the interior space from use for circulation except for aisles on the ground level leading in from every third arch. A series of heavy columns comes directly under those previously mentioned which support the upper deck; but between this row and the next row of columns, toward the center of the arena, a continuous space is provided, forty-four feet wide, which is unencumbered by supports of any kind. This space is undivided and is available for training purposes for all branches of athletics, as well as for exhibitions, carnivals, industrial and trade shows. Along one wing is provided a six-lap to the mile indoor running track for training purposes, so arranged that the coach or trainer can see every portion of it from a central point. While there is sufficient height for pole vaulting along the high side, yet the track authorities venture the opinion that the mental hazard of a concrete roof above will prevent the best work in that branch in the interior quarters.

#### HOW THE FUNDS WERE RAISED.

To the profession the line of thought which has produced the structure herein described is perhaps of at least passing interest. To the layman it will be of equal interest perhaps to know how the project was "put over." It may not be irrelevant, therefore, to make some mention of the plan by which the Ohio Stadium has been made possible.

As has been pointed out in these pages, the current financial support from the State for University purposes is so entirely absorbed in keeping up with the educational demands of the State along purely academic lines, that to expect any assistance from the legislature for a huge athletic plant has never been deemed possible. The influence of far-seeing legislators, however, has made it possible to use the land and to provide from time to time for certain parts of the larger scheme—the great recreational field and those features of it which come under regular campus development and maintenance.

Through the guidance and direction of the Athletic Board, therefore, it has fallen to the alumni and friends of the University to give this great thing to the Institution and to the State. In the fifty years of the University's existence, its alumni have not been generous toward it. In fact, taking for granted that the school is the child of the State, its alumni have never felt the need of giving to its support. But just as its alumni list is growing at the rate of a thousand a year, and these alumni are seeing on every hand the alumni of other institutions giving liberally to the support of privately endowed colleges, they have been called upon to participate in the erection on the campus of their Alma Mater one of the greatest athletic plants in the country.

The scheme has been developing in the Athletic Board for several years, and the Board of Trustees liberally authorized the University Architect to cooperate in the development of the scheme, which made it possible for all commercialism to be removed from the study of the project. The Athletic Board has been assisted by a general committee of alumni and prominent Ohio citizens.

The basis upon which financial support was accorded was upon the sale of seat options. Founders, those whose gifts amounted to \$5,000 or over, secured options on boxes for a period of ten years; Patrons, those contributing from \$1,000 to \$5,000, secured options on six seats; Donors, contributing from \$200 to \$1,000, secured options on four seats, and Subscribers, whose contributions ranged between \$100 and \$200, secured options

on two seats, in each case for a period of ten years.

That the actual study and designing of the Ohio Stadium has been the work of willing hands is evidenced by a glance at the personnel of the force which is responsible for its production. The men who have worked on the problem have been men who are not only interested in its success from an architectural and structural point of view, but who by close ties to the University itself have had a sentimental interest in it which has inspired them to their best efforts.

Professor Joseph N. Bradford, class of 1883, is head of the Department of Architecture and since 1912, as University Architect, has been in charge of all building construction and development on the campus. He has been assisted by Professor Howard Dwight Smith, '07; C. F. Mayer, Jr., '09, and H. F. Reichard, '13. The structural engineering on the Stadium has been in charge of William S. Hindman, formerly of the Civil Engineering faculty and Bridge Engineer of the State Highway Department. Professor Clyde T. Morris, class of '98, has been in consultation on concrete design.

As an alluring commercial venture the creation and use of the Ohio Stadium presents its least appeal. As a great ideal it has crystallized in and about itself a new and vigorous University enthusiasm, a strong community spirit and the loving pride of a great State.

*That our youth may have strength, in spirit, in mind and in the body, to fulfill their broader service to humanity.*





LONDON COUNTY COUNCIL COTTAGES AT HAMMERSMITH.

# BUILDING A NATION SOCIAL ASPECTS OF ENGLAND'S HOUSING PROGRAM

*By*

LAWRENCE VEILLER,  
SECRETARY OF THE NATIONAL HOUSING ASSOCIATION

IT is a thrilling sight to see a nation that a few months ago was fighting for its life, with its back to the wall, resolutely setting itself about the colossal task of building all the houses that the country needs, to the number of 500,000, and at the staggering cost to the taxpayers of over one hundred million dollars' loss every year for a period of sixty years. That is what England is doing.

There has probably been no instance in history where a nation has undertaken housing operations on so vast a scale, and the advantages and disadvantages of the experience thus afforded have value for the other countries of the world.

America faces very much the same

situation, a shortage estimated at a million houses, the almost complete cessation of private building for a period of five years, a serious lack of the requisite materials and labor, with uncontrolled and constantly rising prices, involving rents beyond the purchasing power of the people.

The problem which has confronted the Government in England has been how to meet the housing shortage in the least time at as low a cost as possible, and with the least unsettlement of social, industrial, and economic conditions.

It is beyond the purpose of this article to enter upon a discussion of the merits of the much mooted question of government ownership and operation of public utilities, or of the desirability or unde-



LONDON COUNTY COUNCIL COTTAGES AT HAMMERSMITH.  
Variety obtained by simple means.

sirability of Government's entering the fields of commerce and industry and interfering with the natural laws of trade.

It should be stated, however, that the method adopted by England, of meeting her housing needs at the close of the war, does involve placing upon the taxpayers of Great Britain very heavy burdens. For, the taxpayers of that country are being called upon, to the extent of over one hundred million dollars a year, to make good the loss resulting from the building of houses at a time of excessive costs—houses which cannot be rented upon the basis of an economic rent.

No person can view this departure from fundamental economic law without serious misgivings. It is essentially unsound, and those in the seats of authority in England who are carrying out this policy so regard it. They justify it however, as a post-war emergency measure.

The Government in England, wisely or unwisely, has felt it to be its paramount duty to meet its housing needs in the quickest possible time, irrespective of what it may cost the country, although

every effort is being made to keep down the cost of houses to the lowest possible basis.

What it has done has been to obtain from Parliament large powers with which to deal with this question. The Government has chosen deliberately not to build houses through a central federal organization, but to rely upon the ability of 1,800 different local authorities, scattered throughout England and Wales, to cope with their own local problems, the Central Government furnishing guidance, advice, direction and financial assistance.

The method of furnishing the funds needed has been to approve the issuance of bonds by the larger municipalities, bearing interest at six per cent., and, in the case of smaller communities, to make direct loans from the Central Government. In addition, the Central Government has guaranteed to the various communities to make good the annual loss that is bound to be incurred by building at a time of excessive cost.

In order to encourage private enterprise to reënter the housing field, from which it had almost entirely departed,



the Government is also offering subsidies to private builders of £260 for each cottage erected. As such cottages are costing at the present time on an average £1,000 each, it is apparent that the Government is offering a subsidy of practically one-fourth of the cost of the house, in order to encourage the private builder.

To what extent the offer of these subsidies will attract the private builder back into the field it is hard to say. The latest figures available show that up to September 3 plans had been passed for 18,639 houses to be built by private builders who are to receive the Government subsidy, representing a commitment by way of subsidy of £4,515,008. Already the sum of over £236,633 has been paid out in subsidy by the Central Government for 1,137 completed houses.

The disadvantages of the policy which the Government in England has adopted are chiefly of an economic nature.

Some observers believe that it will mean the permanent elimination from the housing field of the unsubsidized private builder. The natural consequence of this will be the commitment of the Gov-

ernment to the permanent policy of Government-built and Government-operated houses for all the people of the country.

It is also feared that the adoption of the present policy of renting houses below an economic rent will mean the establishment permanently of subsidized houses and the consequent pauperization of labor.

All of this naturally involves the placing of heavy financial burdens upon people already overburdened with high taxes. So far as can be observed these seem to be the chief disadvantages of England's present policy.

The advantages, however, resulting from England's undertaking at this time the task of providing all the houses needed by her people are very great.

In the first place, houses are actually being built to meet the very serious situation resulting from the housing shortage. While the number of houses actually completed at the present time is comparatively small, namely, something less than 3,000, the present indications are that the number produced will in a short time be very large. Up to August 11 83,014 houses had been included in



LONDON COUNTY COUNCIL COTTAGES AT HAMMERSMITH.  
Containing five rooms and bath. In 1911 each house cost £300, as against £1,125 today.

signed contracts, and building had actually commenced on 23,300 houses, of which at that time 2,303 had been completed. The Central Government had on September 18 received from the local authorities over 5,838 applications for the approval of house plans involving the erection of 257,184 houses, and of these 5,122 applications providing for 241,294 houses had been actually approved. Contracts for the erection of 144,615 houses had been approved. It is thus seen that practically one-fourth of all the houses needed are under way.

If there were no other results to be obtained from the Government's embarking on its present policy than the bare meeting of the housing shortage, that alone would seem to be worth while; for, not only is England getting production of houses in large quantities, but the kind and quality of the houses being built literally mark a new epoch in the development of the housing movement the world over.

To appreciate fully what the change means, one must realize the kind of housing that was produced by the operation of private enterprise in England prior to the War. While for many years the Government, through building bylaws (housing ordinances), did control to a large extent the essentials of good living from the point of view of sanitation, the securing of adequate light, ventilation, plumbing, drainage and so forth, it was not able to control the production of houses that were attractive to live in.

No intelligent person who has seen at first hand the dreary miles of monotonous rows of houses stretching in unending distances through the industrial districts of the Midlands, or for miles in the poorer quarters of London, can help admitting that no country could expect to produce from such dreary surroundings citizens of the highest type.

With the exception of the comparatively few houses that were being produced through the splendid enterprise of the Garden City, Garden Village, and Garden Suburb movements, not much was being produced prior to the War other than these unending miles of dreary

"brick boxes with a slate lid," so dreary as to make one almost prefer that other house, shorter and not so wide, but no more rigid in type, referred to in the old epitaph discovered in a wayside churchyard which runs:

"In memory of Rebecca Rogers, who died August 22, 1689, aged 44 years. A house she hath it's made of such good fashion,

The tenant ne'er shall pay for reparation,  
Nor will her landlord ever raise the rent,  
Or turn her out of doors for non-payment.

From chimney money too, this cell is free,

Of such a house who would not tenant be?"

The Government's entrance into the field of housing has meant the end of this period.

It must be admitted, even by one who does not believe in the Government's undertaking enterprises of this kind, that the steps which have been taken in these Government-built houses are so far in advance of anything that has been done in the past, and the types of houses being produced are so good—well-designed and attractive in appearance, with pleasant surroundings, with adequate light and air, with variety of outline and of color and ample gardens; that, apart from the economic considerations involved, the results to England are bound to be productive of tremendous good.

Even though it may cost millions of dollars each year to the taxpayers, England, after all, will get something for the money and will ultimately, if the present Government policy is carried out, be freed from the blight of the slum.

From now on there will be produced no long, monotonous rows of dreary houses all alike. While houses will still continue to be built in rows or groups, there will not be more than eight houses in a group, and as a rule seldom more than six, and generally not more than four, and more often the houses will be built in pairs. Always they will, in whatever combination, have individuality and charm.





LONDON COUNTY COUNCIL COTTAGES AT HAMMERSMITH.  
Neighborhood shops need not be an eyesore.

The type of house hereafter to be built in England for the housing of the workingman will be the cottage and not the tenement. England's experience with tenement houses in the larger cities, where they had been built chiefly by the public authorities to replace slums, had shown her conclusively a number of years ago that this type of house was not one suited to the genius of the British people nor adapted to English conditions. The best of the block tenements have been universally condemned for many years past, and the whole trend of public sentiment in England has been toward the development of the cottage type of dwelling.

It would not be inaccurate to say that so thoroughly convinced is the British public of the undesirability of building block dwellings or tenements in connection with this post-war building, that the question has not even been considered, in fact it was not even raised. Everyone has assumed, as a matter of course, that the only type of house that would be

built with Government funds would be the cottage.

The extraordinary success of the Garden Village, Garden Suburb and Garden City movements, developed to their highest degree in England during the past ten years, has impressed upon the British people the great advantage of having all classes of society, the poorest as well as the richest, live under conditions that are not only sanitary but attractive, with gardens both for flowers and vegetables—in other words, garden communities with all the amenities of civilization.

The houses that are being built are attractive in appearance and of good architectural style, well proportioned, and not encumbered with meaningless ornament, and rely for their design upon line, proportion, symmetry and fenestration.

This result has been achieved by the Government's calling into co-operation at an early date the persons in England who had given most attention through many years to the housing problem.

Among the more important elements

which enter into the new type of houses may be cited the adoption of a larger unit of frontage, namely, not less than 20 ft. Over 90 per cent. of all the houses being erected are houses with a wide frontage. In the past, in the commercial developments the usual frontage had been 15 or 16 ft.

Probably the most important improvement has been the elimination of the so-called back extension, which had become a rather serious evil in England, diminishing light and ventilation and producing an unattractive and inconvenient type of dwelling.

The new type of cottage being built with Government funds is thus a reversion to the earlier type of cottage development found in both the rural and urban districts of England, namely, a house but two rooms deep, securing its light and ventilation from the front and from a generous backyard at the rear, being without courts or air-shafts, and permitting that most important requirement of modern sanitary science—through circulation of air or cross-ventilation.

The type of house adopted is, as a rule, the two-story self-contained cottage type. In some cases cottages of one story and a story and a half are being built, but the predominant type is the two-story cottage. These are, as a rule, being built in groups of four, sometimes of six, often in pairs. Under the requirements of the Government, and in response to what has become practically a general sentiment throughout Great Britain, the number of houses to the acre is being strictly limited to 12 houses to the gross acre in urban communities and 8 houses to the gross acre in rural districts. In the few instances where it has been thought wise to depart from these standards in such crowded communities as London, organized labor has strongly resented this lowering of standards and is threatening to "down tools" unless the Government adheres more closely to the higher standards.

It is of considerable interest to note the changes that are taking place in the English type of cottage, bringing that type much closer to the American type.

Until recently the parlor has not been a usual feature of the English type of cottage construction; but in the new types that have been built by the Government a large number of houses with parlors are being provided, in response to the almost universal demand for such a room.

The upstairs bathroom is also beginning to be provided, although the English still cling strongly to the practice of keeping the watercloset fixture in a separate room downstairs; whereas in Scotland the practice corresponds with the American practice, and the bathroom is found invariably upstairs, and, as a rule, contains the watercloset fixture in the same compartment.

One respect in which the English type of cottage differs radically from the American type is in the absence of a cellar, and consequently of a central heating system. Except in the houses of the rich the cellar is practically unknown. It is possible, therefore, to produce houses at a very much lower cost than would be the case if cellars had to be provided. This, however, makes impossible any central heating system either by hot air, hot water, or steam, though there are some developments in which central station heating is being tried.

It is somewhat surprising to an American to find an open fireplace provided in every room. While it is true that these fireplaces are rather small and narrow from the American point of view, it does mean considerable addition to the cost of construction. The presence of the fireplaces does not mean, however, that fires are maintained in all the rooms in a workingman's cottage. There is not much cold weather in England; that is, cold weather as we know it in many parts of the United States, and fires are, as a rule, maintained only in the living room and scullery. Though fireplaces are provided in each bedroom, I am informed, by persons who know, that fires are maintained in these rooms only when a person is sick. One reason for the providing of the fireplaces is a requirement of the bylaws, based unquestionably on the





LONDON COUNTY COUNCIL COTTAGES AT HAMMERSMITH.

Row houses that are not monotonous.

advantages of ventilation that are secured through the presence of such flues in each room. An interesting variant of this requirement is to be found in the smaller bedrooms where no fireplace is provided. Here, under the bylaws, in lieu of a fireplace it is required that there shall be an open grating in the wall of the room, leading directly to the outer air. It is very strange to look out through these gratings to the outdoor world, and one cannot help wondering what happens to them and to this means of ventilation when cold weather really comes, and whether they are not stuffed up by the tenants in order to keep the cold air out.

Of great interest to the architectural profession is the advice given to local authorities in the "Manual" issued by the Ministry of Health, dealing with the main points of design in cottages of this type. It is here pointed out that there should be adequate frontage given to the building to allow convenient planning, good lighting of all the parts, and the avoidance of back projections. It is

stated that each house should ordinarily include living room, scullery, larder, fuel store, watercloset, bath in separate compartment, and three bedrooms; and, it is added, most schemes should include a considerable proportion of houses having parlors, and also a certain number of houses having more than three bedrooms. In some cases it may be desirable to include a proportion of houses with only two bedrooms.

The number of bedrooms is one of the questions about which discussion rages in England at the present time. At the recent Inter-Allied Housing Congress held in London last June, at which practically all the nations of civilization were represented, there was a strenuous debate on this question, the British delegates wishing to bind the other nations to the acceptance of the principle that a house without at least three bedrooms was not fit accommodation for the ordinary workingman's family. The resolution finally adopted, however, recognized the necessity of adjusting the type of houses to the



LONDON COUNTY COUNCIL COTTAGES AT HAMMERSMITH.  
The charm of curved streets.

different standards and different habits of different people and did not attempt to express in specific terms the actual number of bedrooms which might be required as a minimum, contenting itself with the declaration of principle, namely, that there should be sufficient bedrooms to provide proper accommodation and proper privacy for the different sexes.

How carefully the Government has considered the design of the houses may be noted by the importance that is given to the orientation of the house. In the plans considered and published and widely circulated by the Government and being generally followed in most of the houses that are being built, one will find different groups of plans very much the same in character, but one group marked "Houses with southerly aspect" and another one marked "Houses with northerly aspect."

In the "Manual," already referred to, the authorities point out that the best aspect for the living room is southeast, and add that it must never have a

northerly aspect except when sunlight can be admitted at the other end of the room. It is also pointed out that the living room should be arranged with as few doors as practicable, and that these should be so placed that they will not interfere with the comfort and convenience of those occupying the spaces about the windows and fire.

With regard to the parlor, it is stated that this should be planned so as to leave comfortable space around fire and window; that the best aspect is a westerly one, but that preference should, however, be given to the living room in this matter of aspect. When it comes to the scullery, attention is called to the fact that the scullery especially depends for convenience on arrangement as well as on size, and that when it is used as a place for cooking it should be provided with the necessary space for small table and cupboard. It is further pointed out that, while sufficient space should be given for convenient use, it is not desirable to



encourage the use of the scullery as a living room.

The larder, which takes the place of the American ice-box, it is stated, should be on the northerly side of the house, and it is added that where this is impracticable the window should be screened from the sun. Even so apparently unimportant a thing as the coal storage space has been considered by the Government, and it is suggested that the coal store should generally be so placed that coal may be delivered from the outside and "fetched for use" under cover. When it comes to the bedrooms, it is recommended that these should be placed as far as possible on the more sunny side of the house and that two at least of them should have fireplaces, and adequate ventilation should be provided for any not having fireplaces. In every bedroom there should be one window, of which the top is at least 6 feet 6 inches from the floor, and if sloping ceilings are adopted proper headroom must be provided for furniture.

In addition to these requirements, intended or designed to secure great comfort and convenience in the use of the buildings, consideration has not been lost of the necessity for economy, and it is pointed out that economy must be secured in every possible way. Among other means it is suggested that it may be obtained by adopting simple planning and designing, by placing those parts of the house requiring plumbing and drainage services as near as possible together, by grouping the flues into as few chimney stacks as possible, by adopting a reasonable height for the rooms, and by avoiding needless exterior works requiring periodical painting, such as "barge boards, fascias, and imitation timber." It should not, however, be secured by cutting down unduly the size of the rooms or by unsound methods of construction.

We have seen similar high standards adopted in other countries, and one values the educational purpose that they serve. But in England they do much more than this; for, practically all the houses that are being built at the present

time are conforming to these high standards.

The types of houses being actually built are practically ideal types designed to meet the real needs of the people occupying them, and are consistently designed and of attractive architectural appearance.

It is not too much to say that a new standard of taste in housing is being set, the influence of which will extend through countless generations. It will, unfortunately, take many years to overcome the false standards of taste set by the horrors of the early Victorian style of architecture.

But, with 500,000 houses built in England in conformity with these new and higher standards, it is safe to say that the next generation of English workers who will have had before them a high standard of type of house, during the formative period of their lives, will unconsciously demand the very highest standards in future years.

Not only are houses of the right type being built all over England, but such houses are being placed upon the land in accordance with the very best town-planning practice.

One of the reasons which led the Government to undertake the building of the houses needed by England was the determination to prevent in future the growth of slums and to secure to the great masses of the people of England right conditions of living—the conviction expressed by the slogan, now placarded on the walls of London, "England's destiny is linked with England's homes." There was a clear recognition on the part of the Government of the undesirability of reproducing in future the long, straight, monotonous streets lined on either side with dreary houses, all of one pattern, stretching in monotonous unending rows, about as attractive as miles of cattle sheds. And so it is not surprising to find the new houses being built under Government auspices representing the very best principles of modern town-planning practice.

Under the requirements of the new Housing and Town Planning Act of

1919, the obligation is imposed upon every local authority with a population of 20,000 or more to prepare by January 1, 1926, a complete scheme for the development of all the undeveloped land within its boundaries.

The consequences of this are so vast and are fraught with so much importance to the future welfare of England that it is at first a little hard to grasp their significance. What it means, however, is that in six years from now a rational well-ordered and well-developed plan will have been elaborated, for the future development of all the undeveloped land in towns of any size in England and Wales.

And these plans will be along modern scientific town-planning lines, with a proper consideration of all the advantages that are derived in the United States from the application of Zoning

Laws, from the due observance of the relation between through-traffic thoroughfares and minor residential streets; through the grouping of buildings in civic centres where that treatment is appropriate; through the adoption of gently curving streets, avoiding the unattractive rectangular gridiron plan which prevails in so many American cities; and more especially through preventing congestion of population by the definite limitation of the occupancy of the land, so that there shall not be more than twelve houses to the acre in urban communities and not more than eight houses to the acre in rural communities.

Summed up in a word, it means that the future England is to be made up of Garden Cities, Garden Villages and Garden Suburbs.

England is building more than houses. She is building a nation.



LONDON COUNTY COUNCIL COTTAGES AT HAMMERSMITH.



# IS IT ADVISABLE TO REMODEL ~ SLUM TENEMENTS ? ~

By  
ANDREW J. THOMAS

WITH COMMENT *by* ROBERT D. KOHN

I HAVE been requested to give my opinion on the advisability of remodeling slum tenements in the City of New York. After a very careful review of the situation as one of the judges for the Reconstruction Commission's recent competition\* for the remodeling of slum districts, having examined the numerous plans submitted to the Commission, I have positively come to the conclusion that remodeling is not a practical solution. There are many reasons for this belief. Some reasons rest on facts which are so well known that it is not necessary to do more than to refer to them, while others need to be particularly emphasized. Furthermore, to have real practical value any discussion of the problem should take account of the crisis in housing existing at the present moment.

In the first place, I assume that most people know how miserably deficient are the old-law tenements in the necessities of light, air, sanitation, ventilation, plumbing and heating. Their construction is hardly better than their design, because their builders evaded the building laws as much as they dared and because their owners became discouraged at the carelessness of the tenants and have allowed the buildings to fall into a condition that is not far from actual decay. Twenty years ago the people of New York, by the passage of the Tenement House Act, definitely pronounced those old tenements as below standard. They are much further below standards of decent habitations now than they were twenty years ago, because since then

housing standards have advanced greatly. The adoption of the Tenement House Act was bitterly opposed by both investors and architects, as ruinous to real estate; but after the Act had been in operation a short while everyone saw how necessary and how absolutely desirable it was. Today exactly the same sort of situation has arisen. Because we can build a much higher standard of multiple family dwellings, offering larger and far more secure returns to the investor than the "new-law" tenements permitted by the Act of 1901, and because of changed economic conditions, such as increased cost of construction and improved living standards, it is again requisite to put tenement housing on a new basis.

In deciding whether it is profitable or desirable to try to salvage ruined and obsolete properties, there is first the question of design. The prize design in the remodeling competition can hardly be said to meet even low standards of light, heat and air, with its enclosed courts and with the buildings occupying 71½ per cent. of the lot area. Operation was not thought of when these buildings were originally designed, and it does not appear to have been considered in the remodeled plan. Any one familiar with tenement housing knows what this means. A group of buildings not designed for operation is a poor investment. It is too expensive to operate properly, and its owners usually end by giving up the attempt and allowing their property to deteriorate. Thus the million dollars, more or less, which it would cost to rehabilitate such a block, would probably all be swallowed up in depreciation after a few years, and the property would be structurally about as worthless as it was before the alteration.

To compare this prize plan with new

\*Competition held under the auspices of the Joint Legislative Committee on Housing and the Reconstruction Committee of the State of New York for remodeling the block of old-law tenements bounded by Rutgers, Madison, Jefferson and Monroe Streets, Manhattan.

construction, I submit a plan of six apartment houses, designed to cover the block in question. It contains 384 apartments, with a total of 1,584 rooms, which a competent builder estimates would cost \$1,199,636 to build (50 cents a cubic foot), and yet occupies only 51 per cent. of the area of the block. In a large scale housing operation covering many blocks, however, certain economies, hitherto not considered a possibility, could be introduced which would materially reduce this figure and at the same time reduce the rent. The prize plan provides, on an area of 71½ per cent., 1,481 rooms in 353 apartments, and its estimated cost is \$985,000. The new plan thus offers 103 more rooms at a cost no greater than \$214,636 more than the cost of remodeling, and which probably could be reduced by some \$150,000 through salvaging the materials in the present structures. The following table shows the greater size of the rooms in the new plan:

Size of Rooms.	THOMAS—(OR NEW)—PLAN						Totals.
	Below 70 sq. ft.	71-85 sq. ft.	86-100 sq. ft.	101-120 sq. ft.	121-135 sq. ft.	Above 135 sq. ft.	
Chambers .....	..	..	289	213	50	..	552
Living Rooms .....	..	..	..	..	82	302	384
Kitchens .....	126	258	..	..	..	..	384
Loggias .....	264	..	..	..	..	..	264
Totals .....	390	547	213	132	302	..	1,584
Percentages..	24.6	34.7	13.4	8.3	19.0	..	100
PRIZE PLAN NO. 10							
Bed Rooms.....	25	346	357	42	..	4	774
Living Rooms .....	..	..	38	85	147	87	357
Parlors .....	42	25	..	90	85	64	306
Kitchens .....	..	..	10	10	..	..	20
Dining Rooms .....	..	..	..	..	22	2	24
Totals .....	67	371	405	227	254	157	1,481
Percentages..	4.5	25.0	27.4	15.3	17.2	10.6	100

The new construction plan has almost twice as many rooms, of an area of more than 135 square feet, as the prize plan. It has no rooms below 70 square feet, whereas the prize plan has 67 rooms (4.5 per cent.), of an area ranging from only 52 to 67 square feet—less than the present legal minimum. These are bedrooms and parlors, which are also likely to be used for sleeping purposes, although totally unfit therefor. Two-thirds of the smallest rooms in the Thomas plan are the loggias, which have an exceptional

number of window openings, and the remainder are kitchens. The playground and garden space in the center of the block has an area of 15,850 square feet, almost three times that of the prize plan.

The merits of the comparison can be disclosed only by a study of the primary data upon which this table is based. The rooms in the new plan are uniformly larger in practically all cases. They all open on the outer air, and there is a large number of corner rooms. Whereas all but 46 of the 774 bedrooms in the Prize Plan No. 10 are 100 square feet or less, the smallest chambers in the new plan are 9 feet by 11 feet, an area of 99 square feet. The smallest living rooms are 11 feet by 13 feet, an area of 132 square feet. Furthermore, the rooms in the prize plan are long and narrow. This is especially true of the bedrooms, a very large proportion of which is less than 8 feet wide. The difference is merely that the new plan is modern, designed to meet present-day needs and habits, while the prize plan shows the best that can be done with the relics of the middle ages of tenement house architecture.

Comparing the rental income of the two plans, it is not so easy to determine their relative value. The Committee figured the monthly rental of the prize plan on a basis of \$10 per room, although nearly twice as much is being received for completed apartments which house the same class of people. These are the rental figures of the City and Suburban Homes Co. in their recently completed group, and the reasons therefore should be understood. These are that, following the recent great improvement in financing, a carefully designed financial structure has been built to safeguard the property. In this financial structure the existing abnormal costs of construction are paid for by increasing the rentals for the next few years—which is sound business. This and the fact that the operation of the City and Suburban Homes Co. was not as large in scale as I advocate explain why these rentals are as high as they are. At \$10 per room the monthly rental of the Thomas plan would be \$15,849, or \$989 more per month than could be obtained from the reconstructed



dwellings. The introduction of stores into the group complicates the problem. In the rental figures for the prize plan some forty or more stores, a "movie" and a clubhouse were included, thus sacrificing housing space. This fault could be avoided in the new plan by having only eight stores, although in the plan as shown no stores are included. These could be located in good positions on the corners, and would, as every real estate man knows, produce a higher proportionate rental than a large number of competing stores in old tenement properties. Thus by introducing stores into the Thomas plan its added cost would be largely paid for by the income derived from these sources.

All this comparison of rental, it must be remembered, does not take into account the larger size of the rooms of the Thomas plan, their superior attractiveness, nor the desirability of the rear rooms opening on the garden. In fact, I have said nothing of the infinitely greater architectural value of a newly constructed block with its yard and recreation space.

In a housing development on a large

scale—and after all, the only way possible to get good housing—care should be taken in the preparation of a financial scheme, so that the buildings may, at the expiration of a period of years, not be in the same predicament as our present slum districts are in; when they have served their purpose they should be in a position to be scrapped without loss to the investors.

In working out the financial basis for my plan, I present the following statement, prepared by Mr. T. David Zukerman:

"If costs are to be kept down the financial plan proposed must be practicable and safe. The standards that may safely be set are those that will permit of recognition by the state authorities as legal investments for savings banks, insurance companies and trust funds. This means that there must always be a safe margin between the actual market value of the property and the securities outstanding. Provision must be made for the possibility that building costs may decrease in the near future, and may result in the competition of housing facilities

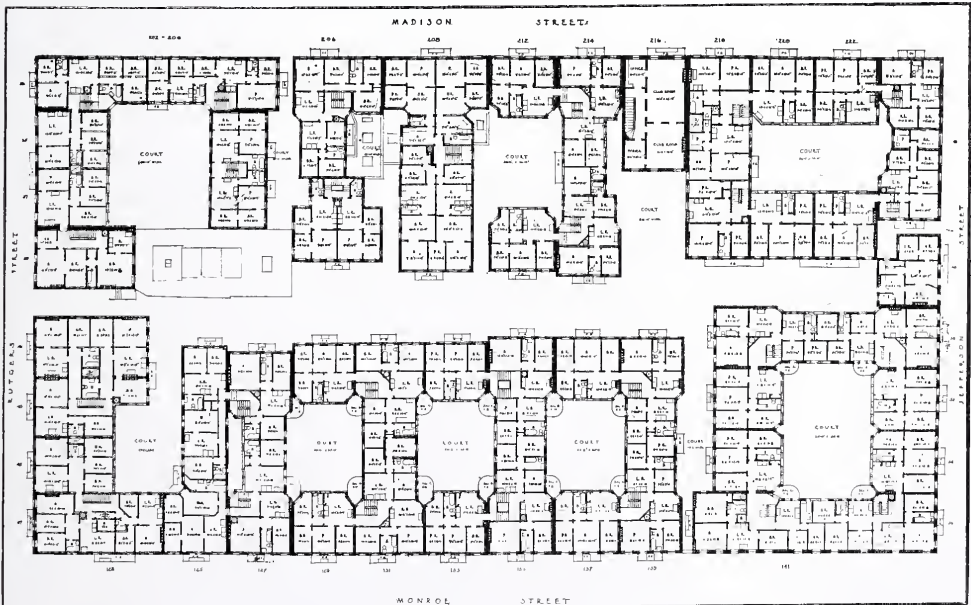

CHARACTERISTIC FLOOR PLAN.

Winning design of Sibley & Fetherston in competition for the remodeling of a New York City tenement block, held under the auspices of the Joint Legislative Committee on Housing and the Reconstruction Committee of the State of New York.

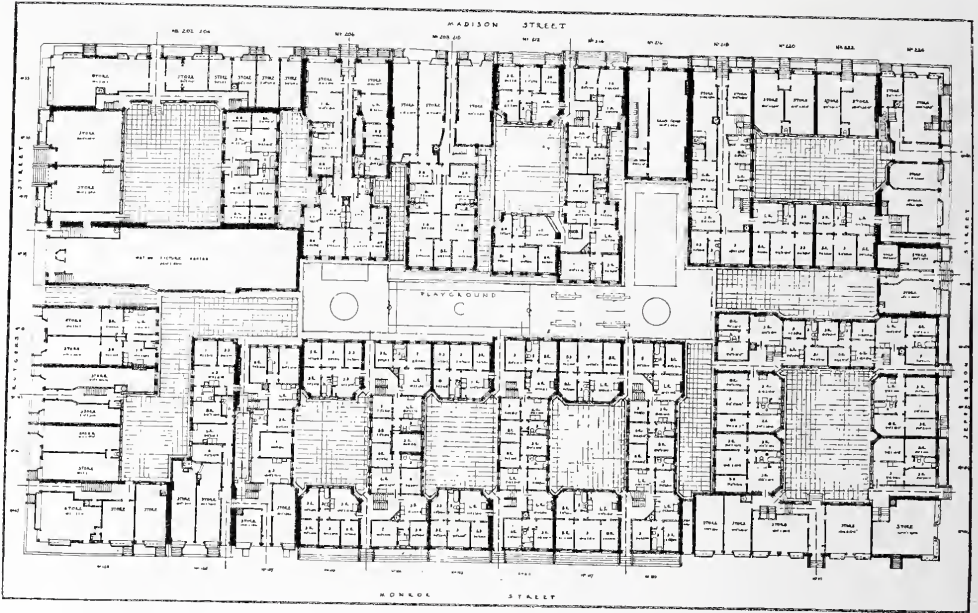

GROUND FLOOR PLAN.

Winning design of Sibley & Fetherston in competition for the remodeling of a New York City tenement block, held under the auspices of the Joint Legislative Committee on Housing and the Reconstruction Committee of the State of New York.

constructed more cheaply than at present, and thought must be given to the question of obsolescence. The financial plan must aim to obviate the retention of depreciated structures after their period of real usefulness is over. It is this condition which creates slums.

"Hence it is proposed that the period of amortization shall be thirty-five years. Within that period every dollar invested, whether on mortgage or otherwise, must be paid off from rentals and all securities representing such investment destroyed. As a further safeguard, especially during the period of reconstruction, at least 30 per cent. of the total should be paid off during the first seven years and 50 per cent. during the first fourteen years. Then, during the next seven years 17½ per cent. should be paid off, and the last 32½ per cent. during the remaining fourteen years.

"The result will naturally be that the rentals, which must be fixed to permit of such amortization, will decrease as the buildings age, and as the process of amortization continues. The payments

themselves can be arranged serially in either annual or semi-annual instalments in such fashion as to stabilize the rentals within the seven year periods. The decrease in expenses will be partly offset by the increase in the cost of repairs and replacements as the structures become older, because a depreciation fund will not be necessary. The depreciation requirements will be fully taken care of by the amortization scheme.

"The money required to finance each group of dwellings should be obtained from the sale of bonds. There might be two or three kinds. For example, assume that an average of \$4,000 per apartment is required to finance the project; the life insurance companies might be called upon to finance 50 per cent. at 6 per cent. interest, or \$2,000. The only difference would be that, instead of a mortgage, the company would have its lien in the form of first mortgage bonds, the maturities of which extend over a period of fourteen years. The prospective tenant would subscribe for the balance, but would probably be able to pay



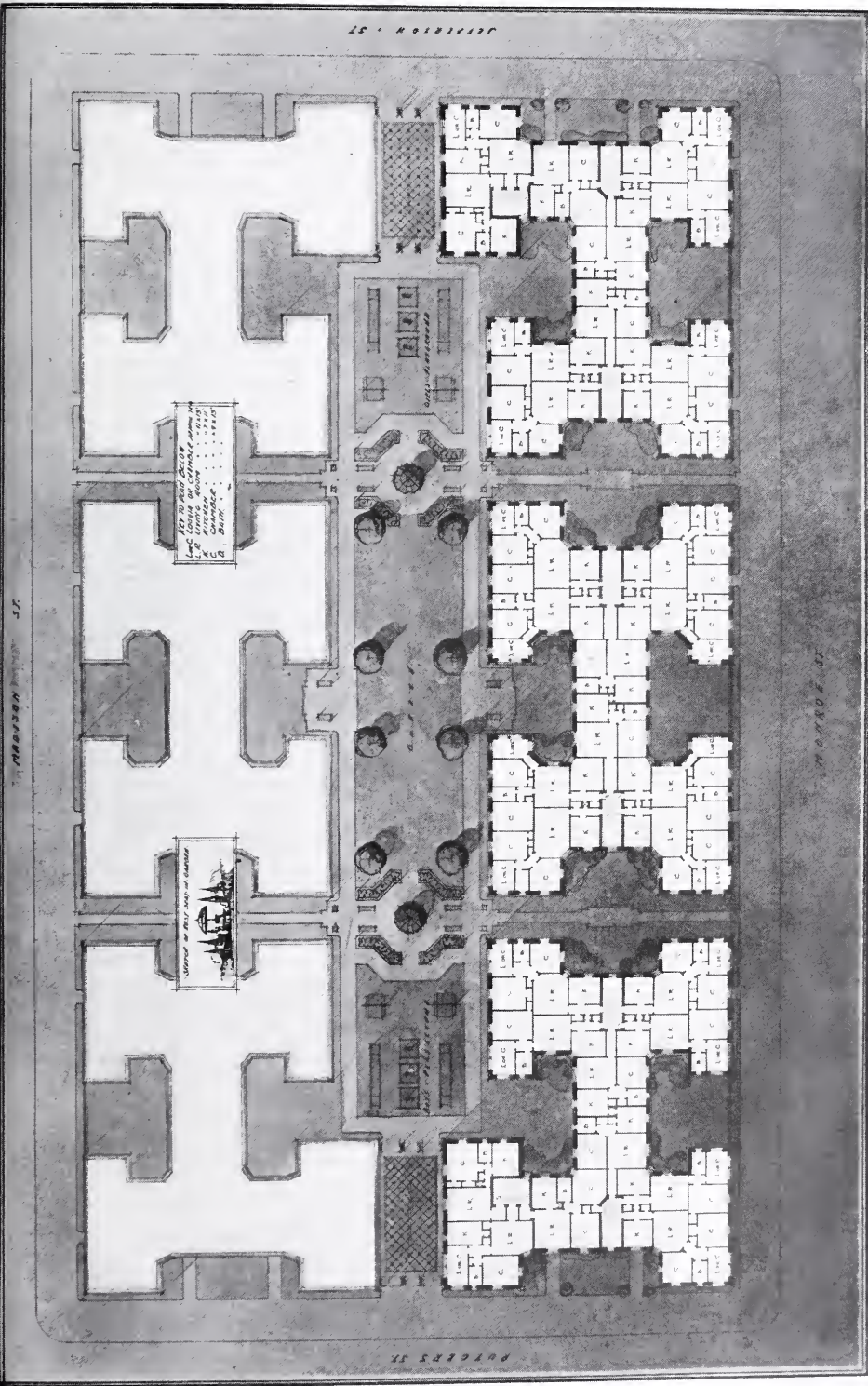

PLAN FOR REBUILDING OF BLOCK BOUNDED BY MADISON, MADISON, JEFFERSON AND RUTGERS STREETS, NEW YORK CITY. SUGGESTED BY ANDREW J. THOMAS.

for his subscription in part. He might be able to pay \$500 in cash and the balance in instalments of \$100 annually for fifteen years. It would thus be necessary to finance the unpaid instalments. These



AN OLD-LAW TENEMENT PLAYGROUND.

could be sold to the general public as sound investments. As they matured and were taken up, they would be transferred to the tenant. Since he would receive interest on his \$500 investment, it would be necessary for him to pay only \$70 additional for the first \$100 instalment, and \$6 less for each additional instalment. The total that he would actually be called upon to pay during the fifteen years would be only \$400 in addition to his initial \$500. In return he would have \$2,000 worth of bonds paying him 6 per cent. interest. The interest would be sufficient to pay from three to four months' rental on the average apartment; besides, the principal itself must be returned to him in the end.

"Summarized, it means that the first mortgage will be retired from rentals within fourteen years. During practically the same period the second mortgage will be transferred from outsiders to the tenants. The margin between the value of the property and the amount of

securities outstanding in the hands of others than tenants increases constantly. Nevertheless, the investments of the tenants are safeguarded as carefully.

"If desired, an insurance feature can be added to the scheme at slight additional cost, to cover unpaid instalments. Then, if the breadwinner dies, the rental must still be paid, but it will be unnecessary to make any further payments on the investment which will, nevertheless, increase just as though they were continued. In case the tenant wishes to move away, he is not tied to the apartment, because he has not bought it. He can dispose of his holdings, either by selling out to his successor or to the com-

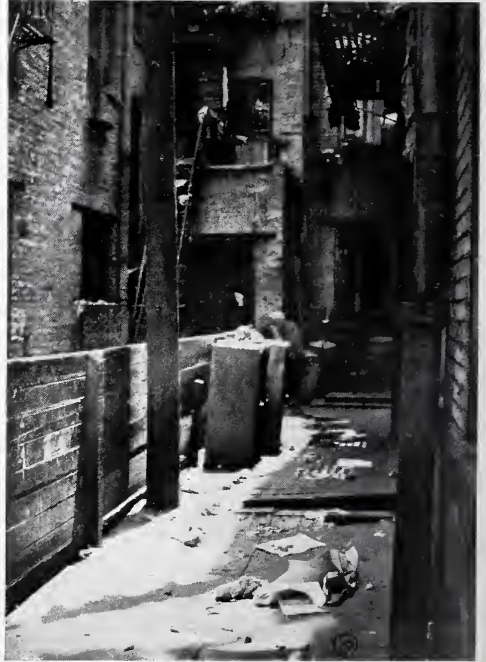

OLD-LAW TENEMENT COURT IN REAR OF 41 RUTGERS STREET, MANHATTAN.

pany which has a fund created for the purpose. Or he can retain his holdings as an investment."

All these factors treated above are important in determining the superior advantages of new construction; but the chief consideration, which beyond all others settles the matter, is the question of the valuation of the properties. This



Monroe Street block is assessed for \$838,000. We should be obliged to add this figure to the cost of building in each case. Thus the cost of operation is:

	Assessed Value	Building	Total
Thomas Plan ....	\$838,000	\$1,199,636	\$2,037,636
Prize Plan .....	838,000	985,000	1,823,000
Difference .....			<u>\$214,636</u>

that it will be high and about the same for each. Even here the comparison is again in favor of the Thomas plan, because it gives better housing and better management. Besides, in the prize plan the rents should be very much increased in the first few years of occupancy, in order to safeguard the rapid depreciation which is almost inevitable in that property.



INTERIOR COURT IN BLOCK DEVELOPMENT OF THE CITY & SUBURBAN HOMES CO., ON EAST SIXTY-FOURTH STREET, MANHATTAN.

This difference is not so great on such a large scale operation, and, as noted above, would be largely offset by salvaging materials in the old buildings and by introducing eight stores. It is not necessary to compute the rental on such a high cost, but the reader will realize

But if new construction is undertaken, the cost of the excessive valuation of the Monroe block need not be incurred. If my plan is constructed on \$3,500 lots the cost of land will be 29 1-5 lots times \$3,500, or \$102,200. Then the comparison is:

	Assessed Value	Building	Total
Prize Plan .....	\$838,000	\$985,000	\$1,823,000
	Land Value		
Thomas Plan ...	102,200	1,193,636	1,301,836
Difference .....			\$521,164

This shows an immense saving in favor of a new plan. This sum of over a half million dollars may be said to represent the real financial risk which would be incurred in undertaking to remodel the old tenements.

Based on this cost of locating apartments on cheap land, the average rent per room per month would begin at \$12 and would descend to \$7.50 after twenty-one years. Spread evenly over thirty-five years the rent would be \$10. This is computed on a construction cost of 50 cents a cubic foot, which could be reduced in large scale operation covering several blocks. Thus the opportunity to choose cheaper land is the great argument in favor of economy of new construction. It is the competition of this new construction on cheap land which the rehabilitation undertaking would be likely to meet.

I wish, however, to emphasize the fact that housing must not be considered in the light of brick and mortar, but must be treated from all its various standpoints, and above all as a human problem. In the block taken for the competition, the areas left open for light and ventilation were filthy and congested with rubbish. We cannot, in our planning, throw too many safeguards around the prevention of repeating these conditions in years to come.

I believe I have said enough to show that considerations of finance, in investment, rental and management, would make is too great a risk to put nearly one million dollars into such ruins as the old-law tenements. I have taken the prize design as the basis of comparison, because I do not believe that the design of Mr. Ecob offers a real solution of the problem.

But in conclusion, I wish to point out that all this discussion of the possibilities of rehabilitating city housing has little practical value unless we consider what agency is to accomplish it.

I have said, at the beginning of this paper, that the whole project should be considered in the light of the unusual conditions in housing which are causing so much public discussion. If it is true that we are facing a crisis, with the need of averting popular disturbances arising from the intolerable conditions, then the only way out of the situation is for the most powerful citizens to effect a combination of the interests of the city, all working together disinterestedly on a large scale, to place the housing industry on the basis necessary to meet modern needs. The most prominent financial leaders should lend their great ability to insure that the undertaking is financed and managed on the soundest business principles. This requires also the full co-operation of labor, working in the same spirit, or the right kind of housing is not possible. Housing is, when all is said, labor's own particular problem, from which labor is the greatest sufferer. With the help of these citizens, working in a limited dividend corporation, its capital drawn from the surplus of the investors of the city—the very people whose welfare is at stake and who profit by the enterprise—then housing may be put on the proper basis. Some such sacrifices as these, like those made in the war undertakings, are needed if we are to prevent the adoption of solutions which threaten the most unfortunate consequences. Municipal housing will be something more than an emergency measure. It is more likely that it will prove the entering wedge for policies which will be extended to every other field of effort.

This, and this only, will be the cure for the slums of New York.



# COMMENT ON MR. THOMAS'S PAPER

BY ROBERT D. KOHN

I am always interested in whatever Mr. Thomas does. I am firmly convinced that he has done, and is doing, the best planned, reasonable cost, multiple dwellings in the United States. I think he has more original ideas on the subject of tenement houses than any other architect I know. And what is more to the point he has not stopped with his first solution of the problem; he keeps developing and does better and better work each year.

Having thus expressed my opinion on the subject of Mr. Thomas's architectural work, I may perhaps be permitted to say that I am not so ardent an admirer of his logic. I am sure that he thinks perfectly straight when he is designing tenement houses, but I am equally sure he thinks less logically when he tries to show, as he does in his article, that it is unwise to consider a scheme for improving the housing of New York by altering the conditions of existing sub-standard tenement houses.

In order to simplify my statement, I will acknowledge at once the obvious fact that New York would be infinitely better off if by some wonderful stroke of good fortune we could get rid of 50,000 old New York tenement houses, similar to those on the Monroe Street block in question and replace them by admirable housing of the type that Mr. Thomas produces. My first point is that this is unlikely to be within the bounds of possibility in my life time. If such things were possible, then I should much prefer to secure a more admirable transformation whereby industry would be so decentralized as to make it unnecessary to house people at the rate of 500 human beings per acre. Mr. Thomas seems to ignore the point that an effort was to be made to see whether anything could be done with the old houses now existing and which never are torn down except to make room for factories and other non-housing developments. To the question, "Do the results of the competition show that anything worth while can be done

with the existing houses?" Mr. Thomas answers, tear them down and put up new houses; the rooms will be infinitely better and the cost will not be very much greater than to alter the old ones.

My reply to Mr. Thomas's argument is that they are not going to be torn down, particularly at a time like this when there is such a frightful shortage of housing in New York. If money becomes available for new housing builders would certainly not tear down existing houses and build new ones in the lower part of the City of New York, but would naturally go to a location where land is cheaper and in healthier environment. Since these miserable houses are not to be torn down, must we leave them standing there as rotten as they are to be occupied as they have been for years by people who cannot pay the price for new and better housing?

What I claim the competition has fairly shown is that there are a number of interesting ways in which existing houses of the "dumb-bell" and other bad types can be improved. I think the competition has shown that, even if an entire block cannot be remodeled at one time as a profitable venture, groups of three or six houses adjoining each other may be changed so as very materially to improve the living conditions. I think the competition and resultant estimates of income have shown that even with a modest increase in rent the resultant income from the improved tenements will probably return 4 or 5 per cent. on the increased investment. I realize that this return is insignificant at the rates that can be had for capital today in some other business. I believe, however, that some owners and others may be induced to improve these existing buildings and do away with some part of the horror of dark rooms, provided a modest return can be earned on the additional investment.

Finally, I answer Mr. Thomas's statement of cost and return on investment from new buildings as against the im-

provement of the old, by saying that Mr. Thomas cannot, at present prices, produce his buildings to rent in New York for less than \$13 or \$14 per room per month (those he has just completed are renting at \$17 to \$20 per room per month). The average rental now received for rooms in the Monroe Street block is something like \$5 per month. The estimate of income from the improved block submitted to the Jury of the Reconstruction Commission was based on a rental of something over \$9 per room per month after

the improvements had been made. Since we cannot with one wave of a magic wand do away with the whole economic structure of the world, will it not be necessary for some time to come to provide less good, less high-priced housing than that furnished in the new model dwellings which will have to rent for three times the price of the old tenement apartments in lower New York? Is it not worth trying to convert some of those old houses into something a little better and at least bearable?



REAR YARDS OF BLOCK DEVELOPMENT AT 511 EAST SEVENTY-EIGHTH STREET, MANHATTAN.



# RECENT DEVELOPMENTS IN HOUSING FINANCE

 By 

JOHN TAYLOR BOYD, JR.

~ PART I ~

SINCE the war an urgent need has arisen for improved methods of financing housing. Owing to the great increase in cost of building construction about twice the amount of capital is now needed in order to put through a housing operation. In the face of this increased requirement, there is less capital for building than before the war. Investors have withdrawn capital from real estate, because they fear the risk of building under the uncertain conditions of the day, and because they can obtain a higher return on well-secured stocks and bonds.

This money-famine has occurred in a time of exceptional housing shortage—a hunger for homes all over the country. The lack of shelter has so threatened the prosperity of communities that, in many cities and towns, the principal business interests have felt called upon to intervene. Hence it is that we see the unusual spectacle of boards of trade and chambers of commerce organizing housing finance corporations in order to stimulate the building of houses in their respective communities. Such a movement is surely welcome, because through it housing finance should be placed on a sounder basis. For the motives, as well as the financial ability of these financing corporations, are high. They demand a fair return on the capital subscribed, which is just; but their chief purpose is to advance the interest of the community, and consequently the interest of the individual home owner. To this end they enforce the highest standards of design and construction in houses; they see to it that the number of new houses built keeps within needs of the city's growth; and they aim to sell the houses—of a type within the wage-earners' means—on the fairest and most reasonable terms.

Here surely—in this triple purpose of raising the standards, of stabilizing the local housing industry, and, most important, of giving the home buyer every possible advantage—is a new departure in housing finance. One need only recall the older financial practices in order to appreciate the contrast. Without reviewing them at length, it may be said that, even in the better class of real estate schemes, the seller did no more for the buyer than the necessities of competition required him to do. He hardly recognized even that principle of modern salesmanship which bids the seller cultivate the needs of his "prospects." A fair product, a fair price—could one ask more? This is the spirit of older selling plans. And as for the less responsible class of housing promoters, the less said of them the better.

Only the building and loan associations seemed to have grasped fully the housing needs and wants of the community. In fact, their admirable system of cooperative housing was developed to fill just this gap that was left by the crude, unscientific finance plans of speculators, whose operation bore so hardly upon the wage earners. To them the building and loan association offered a protection.

While the new housing finance corporations did not develop from the building and loan system, undoubtedly they profited by its example, because they follow many of its principles. And they have the further merits of enlisting some of the leading business ability and the strongest financial resources of the community in the service of housing, and they are able to tap new sources of capital.

Such in brief is the activity of these new developments in housing finance. It

seems evident that they bring a new conception into real estate finance. So significant it is that one should understand its essential character if one is to appreciate all the elements of the technical details of finance of these housing companies. This means, in short, that one should grasp the fundamental human relationships which are at the basis of housing finance. The whole point of housing finance is the human contractual relations which determine the deed of sale. This seems obvious enough, yet it is precisely the weakest point of much of the older housing finance practice. That is true not only in the ways noted above, in the actual plans, but it is also true of most writings on finance. Too often writers become so lost in the intricate technical details of the mechanics of finance—of loans, mortgages, payments—that they overlook the fundamental human factor. Thus the mechanical details come to be thought of as the end, instead of the means.

Accordingly, the first object of housing finance is to picture the case of the home buyer, and the best plan of finance is the one which best satisfies his needs.

The key to the human factor in housing finance lies, I think, in the fact that in the United States the home owner is disappearing. He is becoming a renter. Why did 52.2 per cent. of Americans live in rented homes in 1890, 53.9 per cent. in 1900, and 54.2 per cent. in 1910, with now, as estimated, nearly 60 per cent. of our people living in rented homes? These are telling figures. They prove that increasing numbers of our people are finding home ownership too burdensome to attempt. It is a situation detrimental to both the individual and to society. Essentially, tenantry for the bulk of the populace is not an American ideal. It bids us inquire into the causes, and particularly prompts us to determine how far housing finance customs and practice are responsible for this evil condition of the growing habit of tenantry.

One may safely assume that the normal American appreciates the value of a settled, permanent home in a good neigh-

borhood. The recent popular "home-owning" movement established this truth beyond a doubt—if any proof were needed. Why, then, do people prefer to rent their homes instead of owing them? Here again is an important fact. The reasons for renting should be known in framing any financial plan. The issue of renting vs. home owning is the basis of housing finance.

We must understand the renter's attitude of mind, and, in dealing with it, we should avoid the common error of blindly condemning it without seeking to know its causes. But so convinced of the virtues of home owning are most people that they cannot change their attitude and view the situation through the renter's eye. This is necessary. The best of these new plans of the housing companies show a real desire to meet the renter's objections to owning a home. True, this purpose they do not avow directly, for they are mostly straightforward, matter-of-fact statements of sale plans. They claim only to be meeting a local need in the best way they can. But, whatever be their object, a survey of scores of plans shows that it is just this feature which distinguishes them above older methods. This difference is far more fundamental than methods of handling details, such as mortgages for instance.

For the custom of renting, it must be admitted, has firm root in the conditions of modern society. The truth of the matter is simply that the individual feels himself so insecure, so helpless, in the face of the changes and the complexity of business life, that he fears to buy a home which he may not be able to dispose of at short notice without heavy loss. In other words, a man measures the problem of home ownership by the chances of changing—or of losing—his job. He knows that the chance is always present, and he hesitates to buy a house. He wishes to be free to move. This is the case with all classes of citizens, whether wage earners or salaried employees. Thus renting has a deep hold on the individual, because it rests on the modern desire for mobility in society.

What are the reasons which lead men



to change their habitation? They are various, as might be expected of deeplying human emotions. Some are good, and a few are bad. The more they are thoroughly understood, the easier we may determine which of them can be allowed for, and to what extent, in financing.

The more worthy motives which are at the root of mobility of employment are easily stated. Often a man may lose his job through his employer's fault. The business or factory in which he works may close down, or reduce its force; or change its character, so that it no longer needs his type of services; or it may fail altogether. Also, certain kinds of employment are by nature haphazard, seasonal, hazardous, or itinerant. A man may better himself by changing his job. Then there is always the chance of transfer elsewhere, as a promotion, or the opportunity for better employment in another district. This motive may be strongest with the ablest men who desire to preserve their freedom of choice so as not to lose opportunity when it comes to them. Here, surely, are a set of motives at the bottom of mobility of labor, which are to be judged worthy as long as American enterprise shall be thought a virtue.

Added to these economic reasons which threaten permanent residence, there is a list of personal and family ones. I mean those simple tragedies and disabilities of life which create such havoc in a family. Illness, accident, old age, dependency, death, are some of these. The physician may pronounce the climate unfit for certain members of the family. Again, the family may move to better its position, particularly in order to give better education or better opportunity of employment to children who are coming of age.

Among motives accounted less desirable for changing residence, there is that complex set of factors called "labor turnover." It is not necessary to enter upon this subject at length, except to point out certain of its bearings upon housing.

Even labor turnover is not altogether an evil. In the first place, industrial experts agree that labor turnover is not entirely a matter of restlessness nor of ir-

responsibility. They recognize that the very nature of some employments encourages it. Certain industries, like seasonal industries, develop a class of migratory workers. To young, unmarried workers, a change of employment may be a stimulus—the nearest approach to an education, "seeing the world." For a man who has taken a job, which he finds does not do him justice, it is better to shift than to remain where he is, a round peg in a square hole.

It is not necessary to pursue the motives at the basis of the mobility of employment further. Enough has been said to show how complex are the causes which develop the practice of renting. It is clear that some are stronger than others; that they operate differently in different localities, in different industries, and among different classes and individuals. But no matter what are the conditions of a given problem, one is always dealing with a powerful impulse, perhaps the most powerful human impulse there is—the instinct for self-preservation. Therefore, it is best to give the fullest possible play to the renting instinct in any financial plan. If this is not done, people will rent instead of buying.

In framing specific financial plans, it may not be a wise policy to assume that, in certain localities where labor is apparently contented and conditions seem settled, the habit of renting can be ignored. The conditions may change. If they do change, an inflexible finance scheme which does not allow for mobility of labor may turn out to have aided in developing the renting habit. Correspondence with a number of these finance corporations disclosed this danger. In answer to a question, as to how far they had allowed for mobility of labor in their plans, a few replied that this was not necessary, because theirs was a favored community of contented people who had no desire to go elsewhere, and who were only too eager to buy a home. Despite such optimism, it may well turn out, in the course of years, that these particular enterprises were faulty. They risk somewhat their investment in ignoring the renting instinct because of temporary

conditions favoring permanent residence, which may change in course of time.

Several conclusions may be drawn in this complex problem of the relationship of mobility of labor to the financing of housing. In the first place, it is safe to assume that most of the motives described will be likely to operate, and should be allowed for in the plan. On the other hand, in those peculiar cases where one is dealing with industries where seasonal or itinerant labor is the rule, the best financial plan can hardly prevent renting. Another fact is that extremes of conditions exist. One is the case of small towns where there are only one or two industries. Here the workers will not be willing to place themselves at the mercy—as they conceive it—of a single employer. There is much to be said for this attitude, because in the past employers have been known to take unfair advantage in making wage arrangements when they knew that their employees were tied to a home. There was consequently not that equality of situation which legal opinion holds to be the essence of an equitable contract. At the other extreme are the big labor markets, like Philadelphia or Detroit or Newark, where the workers have little fear of owning homes, since they have such a wide choice of employment among the many factories of the district. However, it must be remembered that the motives, described as family and personal, will still be present in those cases. So, there seems to be no escape from the conclusion that, no matter what the specific situation, the best policy of finance will take the fullest account of the factor of mobility of labor. It is an impulse among individuals which is deeply rooted in the social conditions of the times. Nor can we claim it to be nothing more than momentary unrest due to the war. It is more likely to increase than to decrease, and the statistics quoted above prove that the habit of tenantry has been growing steadily in America for thirty years.

When we come to take account of mobility of labor in a finance plan, one feature is essential. If possible, to satisfy the motive of mobility of labor, flexi-

bility of ownership should be offered. The plan should contain every provision that could aid the owner to dispose of his holding at a minimum loss, if circumstances compel him to move. Right here is the chief point of superiority of these new finance corporations over older methods. They are able to provide a flexible ownership. Working as they do on such a huge scale, the failure of a few individuals to hold on to their property does not embarrass them; and, in addition, their control of the housing industry of the district permits them to discountenance real estate "booms" and thus prevent a surplus of houses. They keep the supply of houses within the demand. Hence they find no trouble in aiding the individual to transfer his holdings to another with little or no loss.

It is easy to see that the older practices of finance, particularly those of speculators, cannot offer the same accommodation to the buyer. A speculator has no control over the supply of houses, and his supply of capital is limited. Consequently he could not accept the risk of offering to take back houses from his buyers. The operation would be likely to cause him or them heavy loss. With this fact apparent, the great weakness of older speculative methods is revealed. Their very nature hinders them from meeting the modern need of mobility of residence. They do not fit conditions and, since they do not, it is pertinent to enquire: Are they not largely responsible for the rapid growth of tenantry and landlordism in the United States?

With the essential need of housing finance thus stated, a description of these new finance corporations and their methods is in order.

As noted above, the movement to form such organizations spread all over the country after the war, principally in the year 1919. They are now found in cities and towns all over the United States, but particularly in the industrial section in the eastern and middle western sections of the country. Just how many of them there are, it is difficult to say. They are still being formed; while of those already organized some are marking time until



conditions in the building industry become more favorable than at present. But it seems reasonable to assert that the number of these board-of-trade sponsored corporations is between forty and fifty at least. They are of all sizes from the \$2,000,000 corporation of St. Louis to the \$200,000 company of Rome, N. Y.

The most striking fact about the organization of these concerns is a general resemblance of type combined with a great variety in details. The variety in details is clearly due to differences in local conditions. They all seem to be aiming at one ideal form, and some of the best of them contain nearly all the best features of the others. For these reasons they resist attempts to classify them, such as is made in the admirable report of the Pennsylvania State Chamber of Commerce. This reports sets forth a number

of plans; but a careful listing of the differences of these plans makes the classification seem arbitrary, and it has the effect besides of making the common mistake in treating finance, as remarked above—that of emphasizing technical details at the expense of the underlying human essentials. So, because of the difficulty of classification, I have thought it better to describe in full the characteristics of these companies, and the principles which they put into operation, with consequent reference to the plans of many companies, in order to illustrate practical points. Particularly is it necessary to show how local conditions govern the working of these principles, emphasizing some in certain cases more than others. How these companies operate will be shown in detail in the next paper.





PORCH — RIVERDALE COUNTRY CLUB,  
RIVERDALE-ON-HUDSON, NEW YORK  
CITY. DWIGHT JAMES BAUM, ARCHITECT.



# RIVERDALE COUNTRY CLUB

RIVERDALE-ON-HUDSON  
~ NEW YORK CITY ~

DWIGHT JAMES BAUM, ARCHITECT



By MICHAEL A. MIKKELSEN

RIVERDALE-ON-HUDSON is a residence neighborhood in the north-western part of New York City. It lies athwart a narrow stretch of land flanked on the west by the Hudson River and on the east by Van Cortlandt Park. The land is well wooded, rolling and hilly, with an average elevation of 200 feet. The neighborhood is laid out with winding streets and rather large building plots, and is suburban in character. The preservation of its suburban aspect is assured partly by real estate covenants, partly by isolation from typical city developments, except on the north and south. Convenient of access, with wonderful views of the Hudson and the Palisades, and with an extensive public reservation of woodland and meadow adjacent, the neighborhood has attracted a population that is fairly homogeneous and, therefore, capable of sharing neighborhood interests. The population consists of about seventy families, some of which are prominent in the social and business life of the city, and all of which are presumably in more or less comfortable circumstances.

About the time the United States entered the war the people of the neighborhood were brought together through their common interest in Red Cross work and in various patriotic activities; and the need for a meeting place arose. It was decided to build a club house, and the Riverdale Country Club was formed, among the members being Cleveland H. Dodge, George W. Perkins, George B. Cortelyou, Arthur I. Keller and Charles E. Chambers. The building, in addition to providing for recreation, was to serve as a com-

munity centre, where something of the spirit and functions of the early New England town meeting might be revived. Since the war its main room has been used impartially for local dances, political gatherings, and the weekly Sunday evening meetings of the Riverdale Forum.

The architect of the building was Dwight James Baum, a charter member of the club. When it was constructed in 1917 non-essential expenditures were under the ban of public opinion. With a view to economy, Mr. Baum designed the furnishings as well as the building, using inexpensive materials and relying for artistic effect mainly upon proportion, line, color and texture. The cost of the club house, including furnishings and equipment, fell within \$25,000.

The design is an unobtrusive version of the Colonial, in keeping with the suburban residential atmosphere of the neighborhood. The site falls abruptly toward the rear, so that the basement floor is on a level with the tennis courts. The grounds are not extensive, Van Cortlandt Park with its golf links being nearby, and consist mainly of two double tennis courts, built over what was formerly a swamp. The clay of the swamp was taken out and replaced by broken stone and clay, making fast courts with good drainage.

The principal room is the "great hall" on the first floor. It is about thirty by sixty feet, with an alcove at one end twenty feet square. This serves variously as a sitting room or "lounge," as a speaker's platform and as a stage; and has a fireplace which burns six-foot logs. On one side of the alcove is a store room



FRONT VIEW—RIVERDALE COUNTRY CLUB,  
RIVERDALE-ON-HUDSON, NEW YORK  
CITY. DWIGHT JAMES BAUM, ARCHITECT.





REAR VIEW—RIVERDALE COUNTRY CLUB,  
RIVERDALE-ON-HUDSON, NEW YORK  
CITY. DWIGHT JAMES BAUM, ARCHITECT.



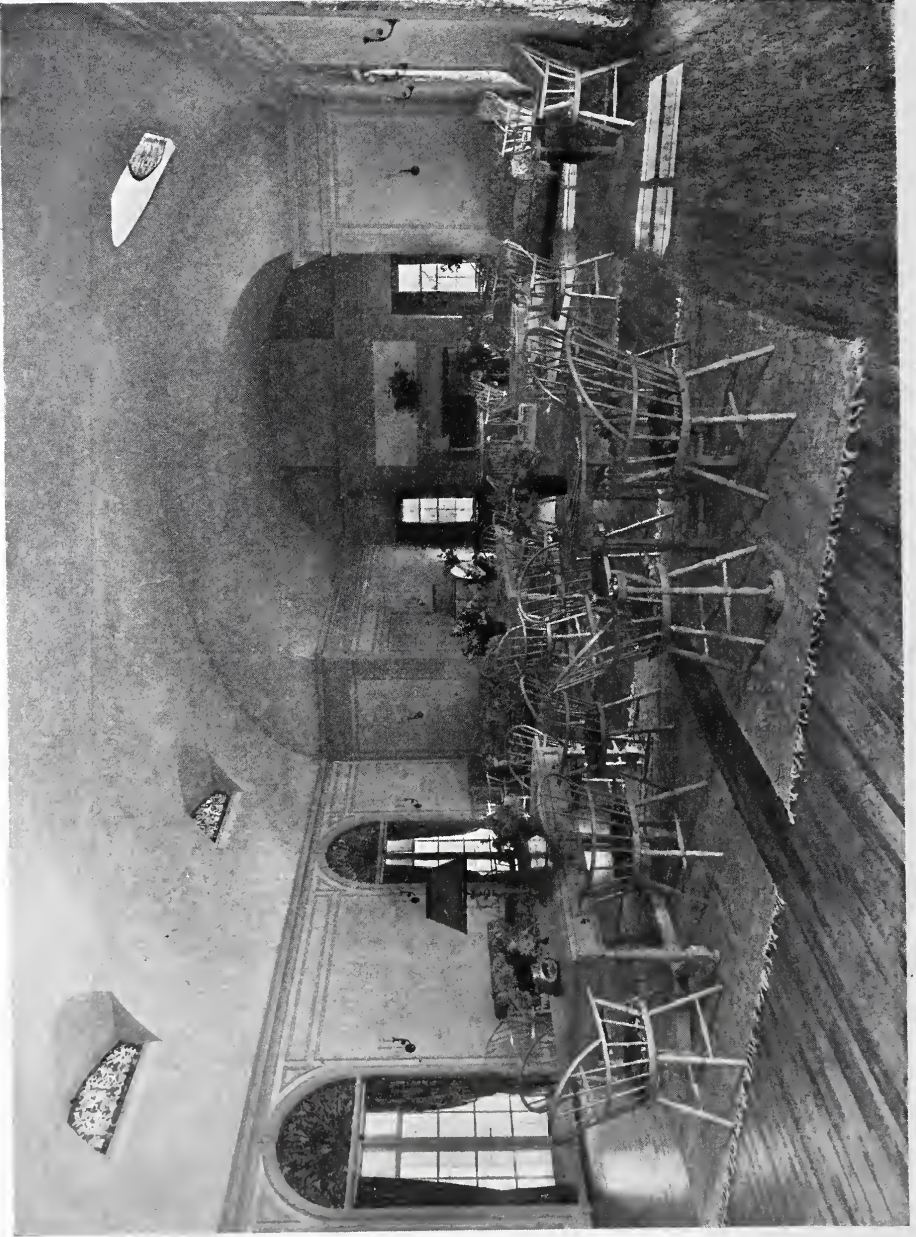

THE GREAT HALL, LOOKING TOWARD ALCOVE—RIVERDALE COUNTRY CLUB, RIVERDALE-ON-HUDSON, NEW YORK CITY. DWIGHT JAMES BAUM, ARCHITECT.



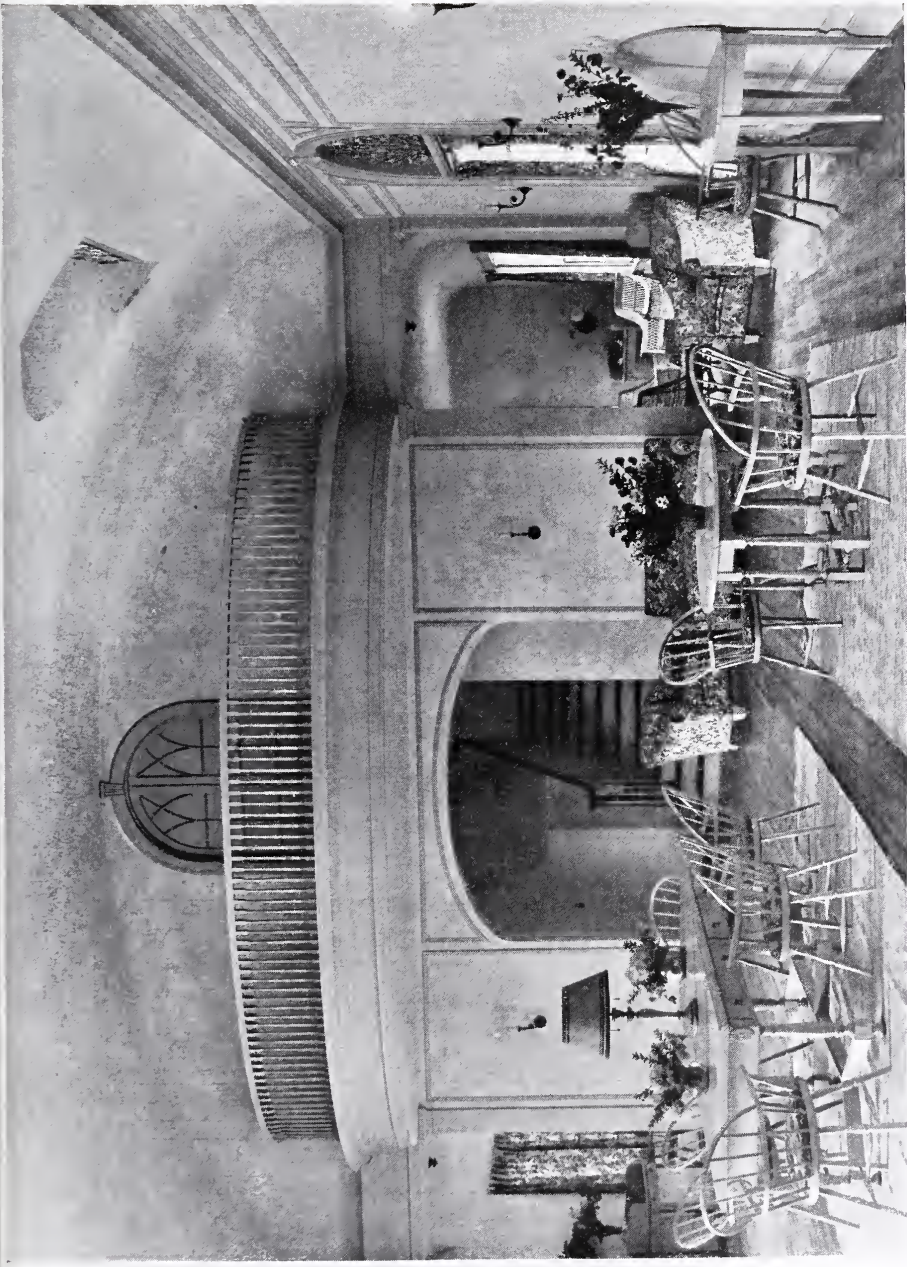

THE GREAT HALL, LOOKING TOWARD MUSICIANS' BALCONY  
—RIVERDALE COUNTRY CLUB, RIVERDALE-ON-HUDSON,  
NEW YORK CITY. DWIGHT JAMES BAUM, ARCHITECT.

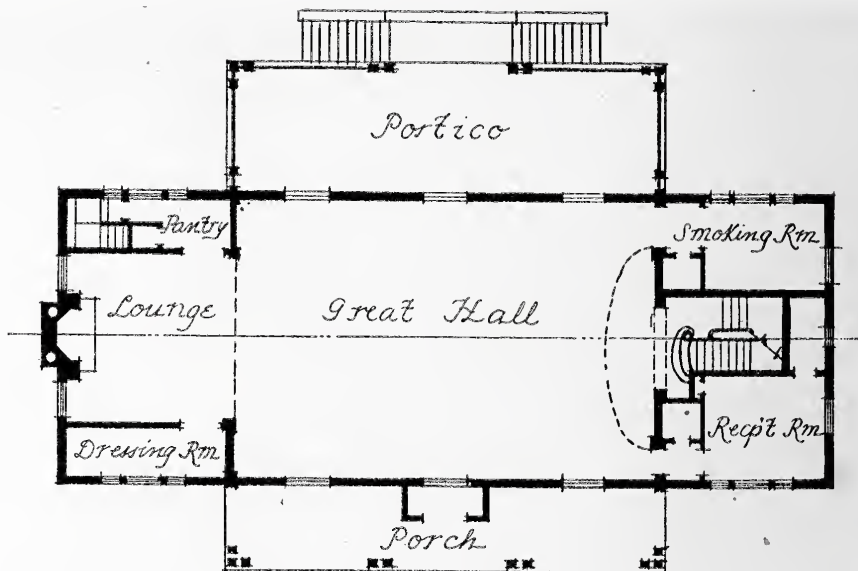

*First Floor Plan*

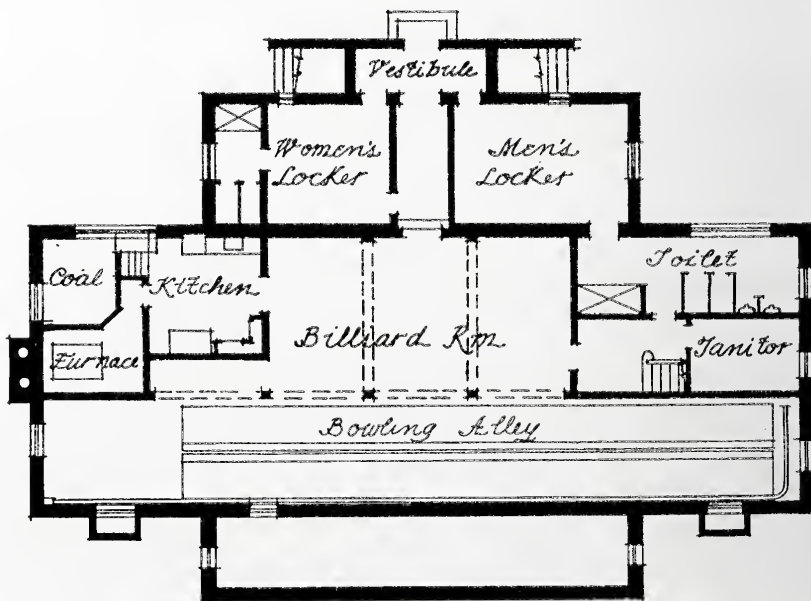

*Basement Floor Plan*

FLOOR PLANS—RIVERDALE COUNTRY CLUB,  
 RIVERDALE-ON-HUDSON, NEW YORK  
 CITY. DWIGHT JAMES BAUM, ARCHITECT.





FIREPLACE OF ALCOVE IN GREAT HALL—RIVERDALE COUNTRY CLUB, NEW YORK CITY.  
Dwight James Baum, Architect.

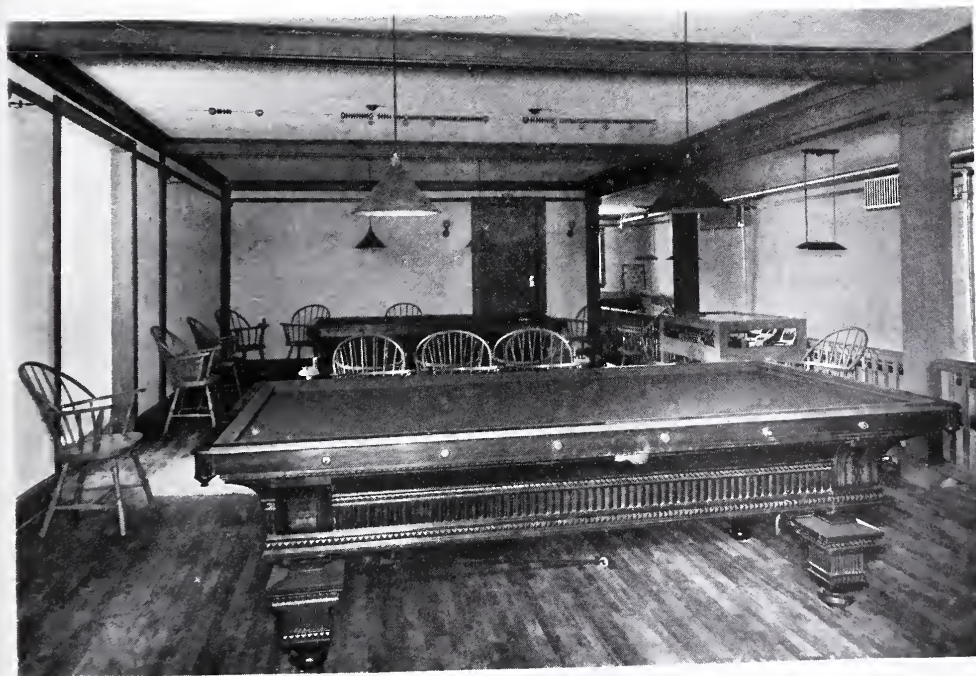

BILLIARD ROOM—RIVERDALE COUNTRY CLUB, NEW YORK CITY.  
Dwight James Baum, Architect.



BOWLING ALLEYS—RIVERDALE COUNTRY CLUB, NEW YORK CITY.  
Dwight James Baum, Architect.

for scenery, and a dressing room; the other side is balanced by a serving pantry, which has a dumbwaiter to the kitchen below, a storage closet for china, and a stair to the kitchen. The arch trim of the alcove forms a proscenium arch.

At the other end of the hall is a staircase leading to the musicians' gallery and to the club rooms below. On one side of the staircase is the ladies' reception room, and on the other the men's smoking and card room. At the rear of the hall is a porch which overlooks the tennis courts, with steps leading down on either side to the courts.

The general color scheme of the main floor is French gray, in both woodwork and furniture; gray cretonnes with birds of bright plumage and with dark flowers give the requisite touch of color, aided

by polychrome electric lighting fixtures.

On the basement floor is a pool and billiard room, bowling alleys, a kitchen adequate to serve one hundred people, a living room for the steward, and two locker rooms with showers, for men and women, respectively. The locker rooms have separate entrances at the level of the tennis courts.

The Riverdale Country Club, in addition to promoting social intercourse, has succeeded in bringing the neighborhood together for action on local civic affairs; and this achievement is without doubt attributable both to the circumstance that the club is neutral in relation to those questions which normally divide a community, and to the fact that the club house is admirably adapted to the dual purpose for which it was designed.



# L'OMBRELLINO, AT PIAN de' GIULLARI ~ NEAR FLORENCE, ITALY ~

*By*

HAROLD DONALDSON EBERLEIN

L'OMBRELLINO (The Little Umbrella), so called in allusion to the little umbrella that tops the weathervane, did not begin its existence as a villa nor has it ever quite achieved independence as a villa in its own right, being an appanage—if one may use so dignified a term in speaking of such an unpretentious place—of the adjacent Villa Pazzi. Nevertheless, L'Ombrellino possesses not a little individuality and an interest of its own from an architectural point of view.

Early in the fourteenth century a part of L'Ombrellino was built by the family of the Bonaccorsi—it was then known as the Spedale della Santa Trinità al Pian de' Giullari—as an hospice for the shelter and succor of sick travelers and for pilgrims going to Monte Ripaldi. It was a modest little building containing a chapel or oratory and an equipment of two beds, with such necessary building as that limited hospital capacity implied.

From time to time additions were made until the fabric assumed its present form, a completion effected, however, at an early date. Its function as an hospice came to an end in the latter part of the sixteenth century when the oratory was annexed to the adjoining Villa Pazzi.

The stuccoed walls are a pinkish grey

in color and the shutters are dark green. The entrance is not on the side facing the little piazza or square of Pian de' Giullari in which appear the old chapel door and another doorway, but is reached by the road at the left and adjoins the gatekeeper's lodge of the Villa Pazzi.

Unpretentious and devoid of all ornament as the exterior of L'Ombrellino is, the interior is even more rigidly simple. There are no vaultings, no carved corbels, no decorative door or window trims, no beams nor painted ceilings. There is no architectural effort whatever about L'Ombrellino either within or without; it is merely a spontaneous utilitarian structure and calls to mind the dictum of a certain architect, anent these Tuscan villas, that "much of their charm lies in the fact that there is so little architecture about them."

Between L'Ombrellino and the Villa Pazzi the connection is so close that, along with the illustrations of L'Ombrellino, are included several showing the little chapel and the entrance to the inner enclosure of the Villa Pazzi. This little detached chapel of the Villa Pazzi stands at the top of a steep, straight roadway which ascends through olive orchards from the lodge and from L'Ombrellino.

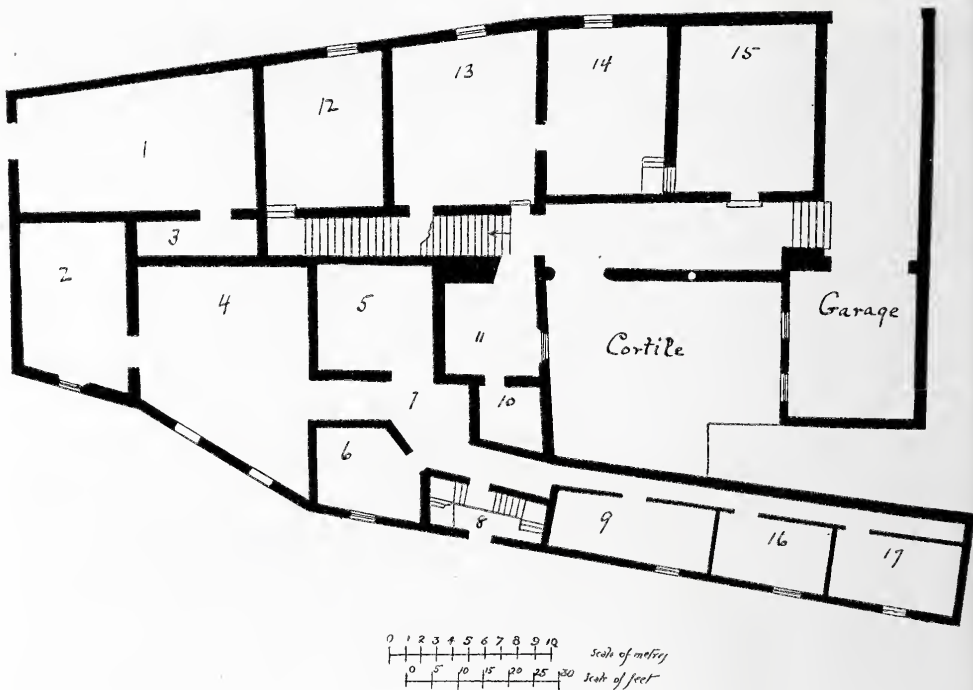

KEY TO NUMBERS ON PLAN:

- |                      |                    |
|----------------------|--------------------|
| 1. Chapel.           | 10. Water Closet.  |
| 2. Room over stable. | 11. Store Room.    |
| 3. Old Sacristy.     | 12. Dressing Room. |
| 4. Bedroom.          | 13. Pantry.        |
| 5. Box Room.         | 14. Kitchen.       |
| 6. Kitchen.          | 15. Cellar.        |
| 7. Corridor.         | 16. Bedroom.       |
| 8. Hall.             | 17. Bedroom.       |
| 9. Bedroom.          |                    |

Ground Floor Plan—L'Ombre.lino, Pian de' Giullari, near Florence, Italy. Owing to the many additions and the great diversity of levels it is hard to say what is ground floor and what is not. The drawing room is one long room above numbers 14 and 15.





NORTHEAST FRONT—L'OMBRELLINO, PIAN  
DE' GIULLARI, NEAR FLORENCE, ITALY.



SOUTHWEST END — L'OMBRELLINO, PIAN  
DE' GIULLARI, NEAR FLORENCE, ITALY.





THE CORTILE—L'OMBRELLINO, PIAN DE  
GIULLARI, NEAR FLORENCE, ITALY.



DRAWING ROOM DOOR—L'OMBRELLINO, PIAN  
DE' GIULLARI, NEAR FLORENCE, ITALY.





WITHIN THE CORTILE—L'OMBRELLINO, PIAN  
DE' GIULLARI, NEAR FLORENCE, ITALY.



DRAWING ROOM — L'OMBRELLINO, PIAN  
DE' GIULLARI, NEAR FLORENCE, ITALY.





CHAPEL AND CYPRESS WALK TO  
FARM—VILLA PAZZI, PIAN DE'  
GIULLARI, NEAR FLORENCE, ITALY.



ENTRANCE AND CHAPEL — VILLA PAZZI,  
PIAN DE' GIULLARI, NEAR FLORENCE, ITALY.





THE CHAPEL—VILLA PAZZI, PIAN DE'  
GIULLARI, NEAR FLORENCE, ITALY.

# A BIBLIOGRAPHY OF MUSEUMS

BY CHARLES OVER CORNELIUS

THE museum building today is peculiarly the manifestation of the changes which have taken place of recent years in the aims and functions of museum administration. Originating as a storehouse to receive and preserve objects of art of intrinsic and aesthetic value, the museum has undergone a transformation into a complicated organization which utilizes this valuable accumulated material in an active effort of definite educational purpose. In this intra-museum transformation, the original aim of the museum—the preservation of the art of past civilizations—has not been lost; but with the addition of the educational aim there are created a number of lines of interest, into which the museum's effort must be directed. A thorough understanding of these aims, familiar enough to museum workers, is necessary to an intelligent solution of the architectural problems which a desire for their realization creates. The literature of this group, which we may entitle "Museum Ideals," is extensive and is continually increasing.

Obviously, the site chosen for a museum building will affect very largely the effectiveness of its work and the safe preservation of its contents. Committees of trustees or other administrative officials are best qualified to judge of the desirability of any given site as it affects certain phases of the actual administration; but, in other questions, the architect can supplement these opinions when the matters of local conditions of climate, atmosphere and soil are presented.

The plan of the building is the vital point in the consideration of the proper functioning of the museum. Two types of existing museum building must be recognized. In the one, the chief interest has lain in designing a great monumental pile with dignified and symmetrical façades and an imposing axial interior disposition, into which the material to be exhibited must be placed as best it can. In the other, the collections

dictate the disposition of the galleries and rooms, each unit being adapted to the best installation of the material for which it is designed, with facilities for its study and use, the whole architectural scheme resolving itself into the finest sort of background and container for the material and activities which prompt its erection.

The practicability of the former method of museum designing is negated by the modern museum ideals of administration and policy; and in selecting a bibliography of museum architectural literature, it seems best to reject treatments of such a nature except where they may prove of interest in the secondary elements of design.

In planning the museum as a container and background, the main considerations are the disposition of the various departments to which the care of the material is entrusted or the museum administration confined, the connections between these departments, and, in the case of exhibition galleries, the circulation within the departments themselves, this latter being dependent upon the arrangement of the actual material. Three types of plan as affecting circulation may be instanced as most frequently utilized either alone or in combination: first, the "basilica" type, with the great central hall, flanked by smaller exhibition rooms; secondly, the so-called "gallery-and-adjacent-corridor" type, which renders unnecessary the use of any gallery for circulation, and thirdly, the arrangement of galleries en suite. In most recent museums will be found combinations of these schemes.

Closely connected with the plan is the method of lighting, whether top or side, and if the latter, whether low, high or clerestory. The actual uses of the rooms must determine the most desirable method of lighting, and this, in turn, affects the plan materially where, for instance, top light is required.

From the question of fenestration, it is but a short step to the treatment of



wall and ceiling surfaces, and yet another to that of floors. In all of these the physical effect upon the gallery visitor must be considered as well as their desirability with reference to the show material. The interior finish, such as floors, walls, ceilings, colors, wood, metal and stone work, is so closely allied with the installation of the material, that here again it is the museum official who holds the key through his familiarity with the uses of the rooms and galleries.

Artificial lighting, heating, ventilating and humidifying are questions for specialists working in conjunction with museum officials. Some experiments have been worked out with regard to these matters, but there has been little publication on the subject, and the most satisfactory information is to be had from museums where various standard methods are found in satisfactory operation.

The works recommended below will therefore be grouped under the above headings for easier reference. The number of books is perforce small, since the changes in the aims of museums have come so recently that many hitherto authoritative works have been rendered obsolete. The purpose, too, has not been to compile an exhaustive bibliography of every book on the subject of museums, but to select a limited number of treatments which will prove of use in designing a museum along the lines of the most recent and approved methods of museum construction.

#### MUSEUM IDEALS.

DANA, JOHN COTTON. *The New Museum*. Newark, 1917.

First of a series of volumes presenting results of study of reaction of the ideals of modern museums upon museum construction, collections and administration. Principal emphasis laid upon educational work of museums.

GILMAN, BENJAMIN IVES. *The Monument and the Shelter*. Boston: Museum of Fine Arts, Communications to Trustees, I, pp. 38-40.

Distinguishes between purposes of the new and the old museum.

*On the Distinctive Purpose of Museums of Art*, *ibid.*, pp. 42-53.

A discussion of the relative import-

ance of the aesthetic and didactic values of museum collections.

\**Museum Ideals*, pp. 3-17. Boston, 1918.

GROSSE, ERNST. *Public Art Collections, their Aims and Arrangement*. Boston: M. F. A., Communications to Trustees, I, pp. 65-75.

The interpretation by a European Museum Director of the aims of public art collections. (Reprint.)

PRICHARD, M. S. *Current Theories of the Arrangement of Museums of Art and their Application to the Museum of Fine Arts*. Boston: M. F. A., Communications to Trustees, I, March, 1904, pp. 3-25.

A comprehensive statement of the aims and methods of the modern museum.

BOSTON MUSEUM OF FINE ARTS. *Certain European Museums: approaches and surroundings of, recommended to consideration*. Communications to the Trustees, III, Jan., 1905, pp. 16-17.

JACKSON, M. T. \**The Museum*. Chapter I. New York: Longmans, Green & Co., 1917.

#### THE BUILDING.

BOSTON MUSEUM OF FINE ARTS. *Plans and Description of New Building*. Guy Lowell, architect. M. F. A. Bulletin, Vol. VII, Nos. 40-41-42.

*Plans and Views*. American Architect, Vol. CIX, No. 2101, Mar. 29, 1916.

*Evans Memorial Wing*. M. F. A. Bulletin, Vol. X, No. 57. Sketch, perspective and plans. Vol. XIII, No. 75. Plans and photographic views.

BREWER, CECIL CLAUDE. \**American Museum Buildings*. Journal of the Royal Institute of British Architects, Vol. XX, third series, 1913. pp. 362-398.

General discussion, views, and plans of the following museums: Pittsburgh, Carnegie Inst.; Philadelphia, Univ. Penn.; Boston, M. F. A.; New York, M. M. A.; Toledo; Buffalo, Albright; Washington, National, Corcoran Gal-

\*Works containing comparative or composite plans or ideas, and therefore of particular usefulness, are prefaced in this list by a star.

- lery; Chicago, Field Columbian, New Field; Detroit, Aquarium; Brooklyn.
- CLEVELAND, OHIO, *Museum of Fine Arts*. Plans, views and description. *Architectural Record*, Vol. XL, No. 3, pp. 195-211.
- EUROPEAN MUSEUMS *Descriptive Index of*. Plans, sections and views discriminatingly chosen. Boston: M. F. A., Communications to Trustees, III, pp. 115-126, pl. 1-87.
- Recent European Opinion on Museum Methods*. Boston: M. F. A., Communications to Trustees, II, Dec., 1904, pp. 44-53.
- Deals with show and study collections and the methods of museum arrangement.
- JACKSON, M. T. *The Museum*. Chapter II, The Architectural Plan.
- LOS ANGELES, CAL. *The South West Museum*. Plan. *Architectural Record*, Vol. XLII, p. 20.
- LUCAS, FREDERICK A. *American Museum Buildings*. *Journal of the Royal Institute of British Architects*, Vol. XXII, third series, 1915, pp. 17-24.
- A reply to Mr. Brewer.
- MEYER, A. B. *Studies of Museums in the United States and Europe*. Washington: Govt. Printing Office, 1905.
- Most extensive handbook on Museums and kindred Institutions. Portions obsolete. Good plans. Takes up all questions related to Museum building, each in conjunction with particular buildings.
- MINNEAPOLIS, MINN., *Institute of Arts*. Very full description illustrated with views, plans, elevations and sections. *American Architect*, Vol. CVII, No. 2052, Apr. 21, 1915.
- NEW YORK, *American Numismatic Society*. Plans. *American Architect*, Vol. XCI, No. 1644.
- Metropolitan Museum of Art*. New Wing of Classical Antiquities. Plans and view. *Bulletin*, M. M. A., Dec., 1917, Vol. XII, No. 12, pp. 243-244.
- Pierpont Morgan Library*. Views and plan. *American Architect*, Vol. XCV, No. 1724, Jan. 6, 1909.
- PAZAUREK, DR. GUSTAV E. *Museum Buildings*. Summary of answers to questions which present themselves by reason of unsatisfactory existing conditions in museums. Boston, M. F. A., Communications to Trustees, I, pp. 54-64.
- ROGERS, MEYRIC R. *A Study in Museum Planning*. *Architectural Record*, Vol. XLVI, pp. 518-528.
- A recent and valuable contribution to Museum Planning. "Being an effort to establish a working basis for the solution of current problems in Museum Planning."
- SANTA FÉ, N. M., *The New Museum at*. Text, views, plans. *Architectural Review*, Vol. VI (old series XXIII), No. 2, Feb., 1918, pp. 17-19, pl. X-XIV.
- SOUTHAMPTON, L. I., *Parrish Museum*. Successful small museum. Plan and views. *Architectural Record*, Vol. XXXVIII, pp. 525-538.
- STURGIS, R. CLIPSTON, F. A. I. A. *Museums for the Exhibition of the Fine Arts*. Suggestions on Planning and Installation. *Journal of American Institute of Architects*, Vol. I, pp. 147-160.
- Report on Plans Presented to Building Committee*. Boston: M. F. A., 1905. Illustrated.
- TORONTO, *Museum of Fine Arts*. Plan and description of building. *Museum Work*, Vol. I, pp. 183-185.
- WASHINGTON, D. C., *National Museum*. *American Architect*, Vol. XCIII, No. 1696, June 24, 1908.
- WEISSMAN, A. W. *Gallery Building*. *Journal of the Royal Institute of British Architects*, Vol. XIV, No. 2, pp. 417-451.

LIGHTING.

- AMSTERDAM, HOLLAND. *Report of the Royal Dutch Commission on the Lighting of Rembrandt's "Night Watch"*. Reasons for adoption of a southwest sidelight. Diagrams. (Reprint.) Boston: M. F. A., Communications to Trustees, II, Dec., 1904, pp. 54-75.
- BOSTON, M. F. A. *Lighting of Galleries*. Communications to Trustees. Jan., 1905, pp. 25-39.



\*Communications to Trustees, III, pp. 75-80, 90-112.

Schedules of European Galleries giving dimensions of rooms, size and positions of openings.

\*Communications to Trustees, IV, Jan., 1906. The Experimental Gallery.

Results of experiments in Gallery Lighting for all types of objects. Diagrams and photographs of objects under various lighting conditions.

GILMAN, B. I. *Museum Ideals*. Boston, 1918, pp. 137-248.

*Glare in Modern Galleries*. Architectural Record, Vol. XXXVIII, Nos. 2-3, pp. 262-280, 362-378.

#### INTERIOR FINISHING AND INSTALLATION.

BOSTON, M. F. A. Communications to Trustees, III, Jan., 1905. On Color, pp. 53-56. On Arrangement, 57-65.

JACKSON, M. T. *The Museum*. Chapter III, Preparation for the Collections.

ROBINSON, EDWARD. *Pedestals for Sculpture*. Text and Illustration. Museum Work, Vol. I, pp. 203-207.

STURGIS, R. C., F. A. I. A. *Suggestions on Planning and Installation*. Journal of A. I. A., Vol. I, pp. 147-160.

#### HEATING, VENTILATING, HUMIDIFYING, ARTIFICIAL LIGHTING, ETC.

BOSTON, M. F. A. Communications to Trustees, III, Jan., 1905, pp. 67-68.

MEYER, A. B. *Studies of Museums in the United States and Europe*. Washington: Government Printing Office, 1905. See under various museums.

#### BOOK REVIEWS

THE PRACTICAL BOOK OF INTERIOR DECORATION. By Harold Donaldson Eberlein, Abbott McClure and Edward Stratton Holloway. J. B. Lippincott, Philadelphia, 1919.

To quote from the authors' foreword, "it is hard to understand why someone has not written such a book as this before." It answers a need in modern life for information and direction in the matter of interior decoration, set down in a form useful equally to architects, decorators and interested laymen.

The subject matter falls naturally into

three parts. The first takes up historic period decoration in England, Italy, Spain and France as a necessary basis for part two, wherein is considered practical decoration and furnishing in the light of past and present knowledge. The third part develops the method of decoration and furnishing which is put forward as the most satisfactory for modern usage.

Part I correctly assumes that those decorative forms that have value today are a result of the leaven which the Renaissance early in the sixteenth century introduced into all the arts. Throughout this study, a consistent scheme has been adopted (reminiscent of Banister Fletcher's Architectural History) of dividing the discussions in each country and each period into the definite subdivisions of the decorator's art—architectural backgrounds and fixed decoration, furniture and decorations, other decorative accessories and movable decorations, materials and color, arrangement—which, facilitating comparisons, render more significant the changes from period to period in usage of forms and materials. In the chapter of this part dealing with the nineteenth century is a judicial statement of the aims of the modern method of interior decoration.

In Part II the practical details of decoration and furnishing are gone into with considerable thoroughness. Four methods of furnishing are suggested, each succinctly stated with its virtues and defects. Then the more technical questions of execution are considered from the points of view of color: the treatment of walls, floors, windows, and artificial lighting, the choice of furniture and textiles and the use of small accessories.

In Part III is taken up the spirit of the Renaissance as it spread throughout Europe and showed itself in its various incarnations in Early Renaissance, Baroque, Rococo, Neo-classic. Here, again in detail, are considered the elements of Renaissance design—the use of materials and color, the choice of forms for the units of furniture and the points of relationship between styles in the several countries—as an expression of the same art impulse impregnating all.

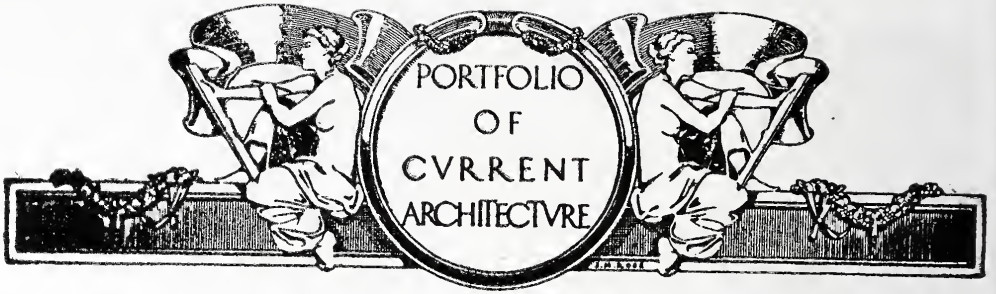

PORTFOLIO  
OF  
CURRENT  
ARCHITECTURE



LITTLE THEATRE, SANTA BARBARA, CAL.  
WILLIS POLK & CO., ARCHITECTS.



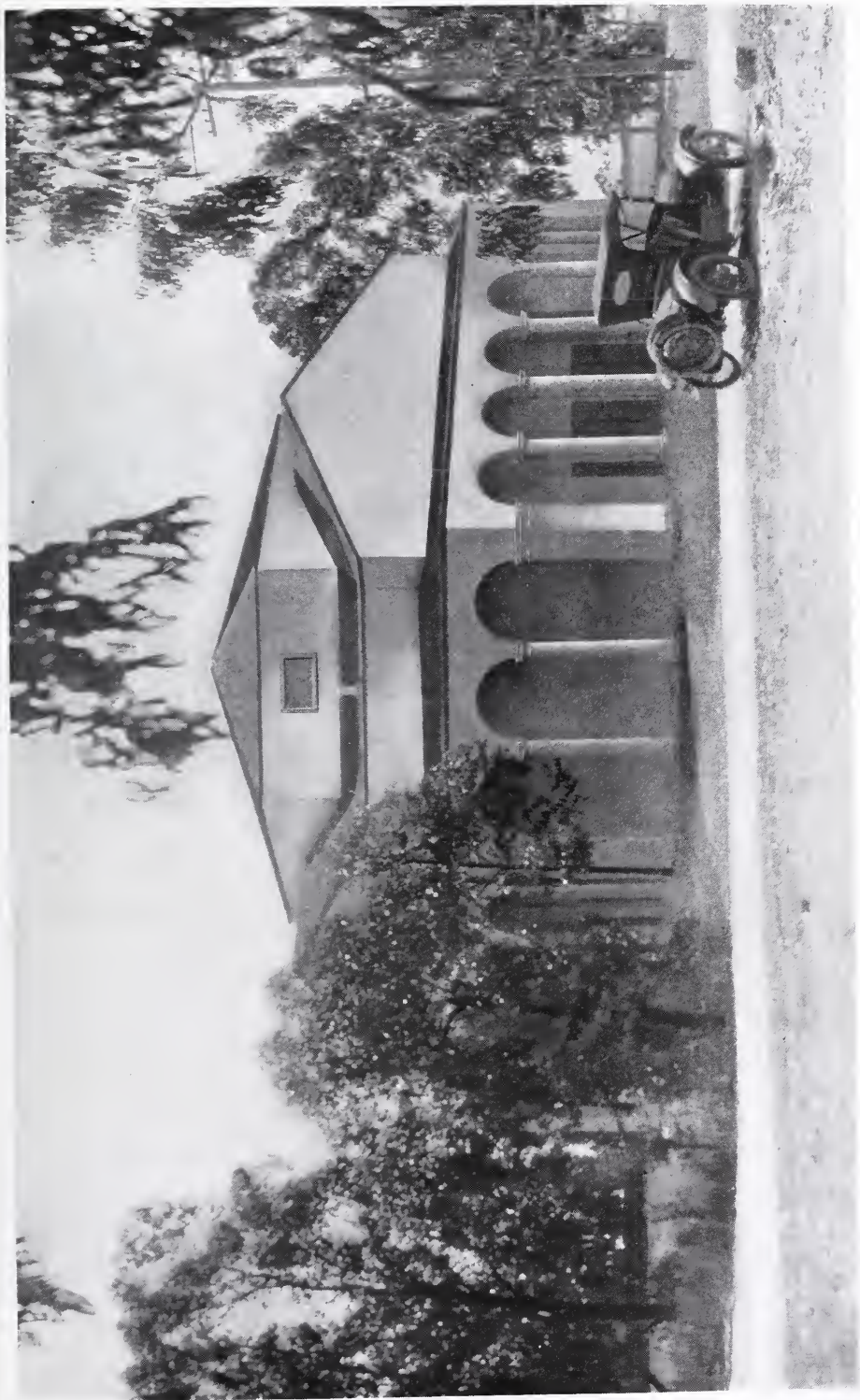

LITTLE THEATRE, SANTA BARBARA, CAL.  
WILLIS POLK & CO., ARCHITECTS.



LITTLE THEATRE, SANTA BARBARA, CAL.  
WILLIS POLK & CO., ARCHITECTS.



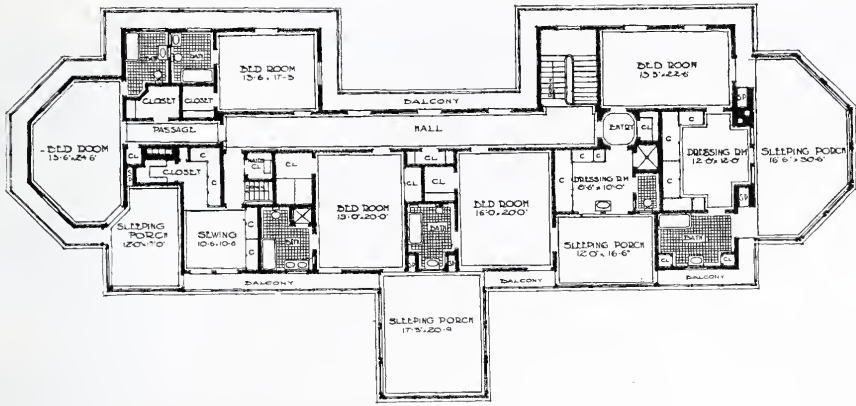

SECOND FLOOR PLAN

WILLIS POLK & CO  
SAN FRANCISCO, CALIF.

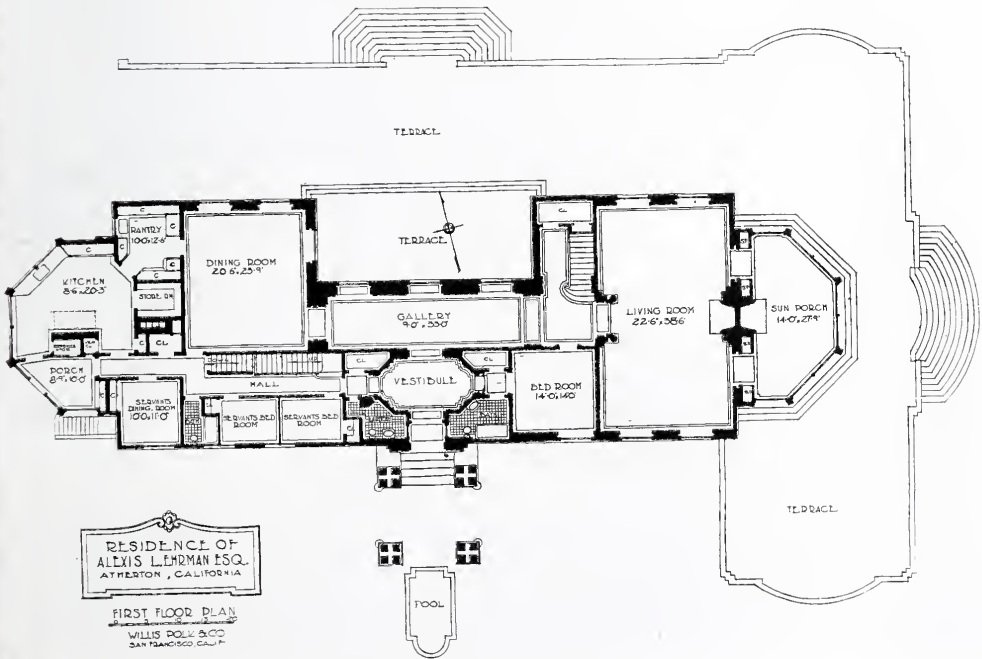

RESIDENCE OF  
ALEXIS LEHRMAN ESQ.  
ATHERTON, CALIFORNIA

FIRST FLOOR PLAN  
WILLIS POLK & CO  
SAN FRANCISCO, CALIF.

FIRST AND SECOND FLOOR PLANS—RESIDENCE  
OF MRS. ALEXIS L. EHRMAN, ATHERTON,  
CAL. WILLIS POLK & CO., ARCHITECTS.



RESIDENCE OF MRS. ALEXIS L. EHRMAN, ATHER-  
TON, CAL. WILLIS POLK & CO., ARCHITECTS.



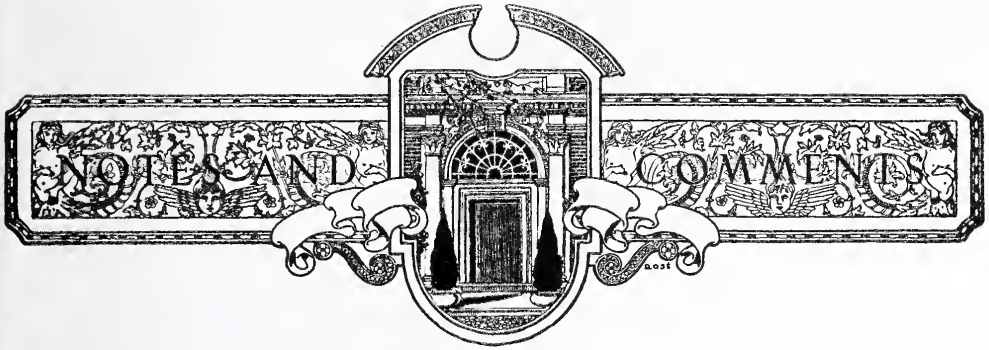

**A Jury of Artists  
Appraises the  
Architecture of  
Los Angeles.**

desires information about architecture often finds himself baffled when he applies to individual architects. He may receive from them opinions that are not clearly expressed, or which may be partisan. Sometimes a layman may recognize clearly that he is not talking to an artist, but rather to a specialist who is more interested in technical points than in salient aspects of design. So long as artists stand apart from the world, in dire confusion of ideas, unable to agree on standards or ideals or principles, or style or taste, why should they expect anything but indifference from the public? If without convictions in art themselves, how may they hope to convince others?

American architects are further from this unhappy condition, and are leaving it behind them faster, than other classes of artists. Before the war, it seemed clear that, in the east, the Philadelphia architects had really succeeded in establishing a native art in their regional architecture. The Philadelphians were followed closely by New York architects, who, since the war, are equalling them with their own regional type. Yorkship village and the Bridgeport war housing, designed by Electus D. Litchfield and R. Clipston Sturgis, are native American art. The goal is in sight when leaders like Charles A. Platt, John Russell Fope, Mellor, Meigs & Howe and Cass Gilbert, in their latest published work, forsake eclecticism and cosmopolitanism for native styles. Then there are the younger men,

to whose researches and training, more than anything else, go the credit for the achievement. Now we are beginning to see that on the west coast the Californians have performed similarly.

Of course, the result does not please our intellectuals. It does not meet their preconceived ideas of what American art would be. There is nothing new in their predicament. Dante and Boccaccio scandalized the critics of their day by seeking inspiration in the vernacular. For, like our own, those old Italian critics were committed to cosmopolitanism, in the form of it then prevailing which insisted on following Latin models. "How can you," they said in effect, "expect to be read by cultured people the world over, when you write in a local dialect that only the vulgar of Florence can understand?"

This, then, is the deliberate purpose of leading architects—to design in a local style that the people can understand, and which, incidentally, they and their draughtsman can understand. That is why this California action is so interesting. It is as clear and coherent a formulation by native artists of the ideals of native art as exists so far. Hitherto, architects have left it to others to read their ideals from their works. Their written judgments have been limited to reporting the results of competitions for projected buildings, and hence have been concerned with paper architecture, in which some of the real fundamentals of art can hardly be determined. Only completed buildings can reveal the picture of architecture in its outdoor setting, can demonstrate how its design is profoundly influenced by the shapes and lives and colors of the land and of the foliage surrounding it and enframing it—above all, the clear, brilliant sunlight which floods the whole scene. From such influences come the

fundamental qualities of style in architecture. And, as they are geographical facts which vary in each region, they enforce local or regional style in architecture. This truth, scarcely realized yet in modern architecture, is strikingly evident in California. Those great sweeps of mountain and plain must not be negated by the slopes and lines of architecture or of garden. That statuesque, often decorative foliage, must be worked into the decoration of walls and forms, often forcing them to take a subordinate place, as screens or foils for trees and shrubs and the play of shadows. That strong sun requires light, clear color if the color of architecture is to be in key with it; in some cases it requires that the building be a simple mass in order to count in the midst of so vivid a landscape. How can you fit an art suited to misty, rainy, grey North Europe into such a scene? How can you standardize that South California outdoors into any intellectual abstraction of cosmopolitanism or of world culture?

Such is the ideal of art and of criticism that the Californians have established. Their criticism is thorough, clear and of real vision. They organized a jury of architects, landscape architects, and other artists who chose the "ten most notable examples of architecture, the five of landscape architecture, the three of public sculpture, and the five most notable examples of small houses"—all of them within twenty miles of the Los Angeles City Hall. Note that twenty-mile radius struck from the Los Angeles City Hall, in its significance to a regional art. The findings of the jury were embodied in a report, fully illustrated with photographs and drawings, published in the *Architect and Engineer* of San Francisco, in the August issue, where it occupies seventy-three pages.

Besides the great significance of their establishing principles of a native art, there are other points of interest in the report. Some of its conclusions apply elsewhere in the United States. The committee emphasizes the importance of house architecture. They point out that no business building has a place on the list. They refused altogether to list the public sculpture. Public architecture was similarly pronounced deficient except for schools and libraries., and among the ten most notable buildings five were residences. All this means simply that the immediate future of American art lies in the art of the home and of the small town. This again may jar certain critics, misled by the theatrical qualities of our skyscrapers and by the ignorant

praise of them by visiting Englishmen of letters. Our city architecture will be successful only when we attain a rational and an artistic conception of a city, together with a tradition and a culture formed upon it. Meanwhile our native art develops in those of our smaller communities and neighborhoods which are not commercialized.

It may seem strange thus to speak of architectural traditions in California. They derive from the half-dozen old buildings left by the Spanish missionaries. This choice has been considered by some to be an affectation, but they are mistaken. These old Spanish master works were a simple provincial derivative of an architecture that was developed in a somewhat similar geography in Spain. The California architects, therefore, found ready to hand in the old mission buildings the fundamental qualities of a native style, and it is to their credit that they recognized the value of what they saw. Within the last generation they have progressed rapidly, incorporating into the old style the modern ideas of flexible planning which came originally from Paris, the domestic atmosphere of the Anglo-Saxon in its American variety, and modern ideas of color and of decoration. The result is a beautiful native American architecture already counting to its credit many master works of art.

Such art, such judgment by artists, is a real event in American culture. It points the way ahead to all architects, and, one may believe, to other artists. But, even more than that, it shows that the architects on the Pacific Coast, as well as those on the Atlantic coast, have developed a native art and have found a public that welcomes it.

JOHN TAYLOR BOYD, JR.

#### **The Passing of a Unique Office Building.**

A striking illustration of the rapid change in architectural practice is found in the contrast between the typical skyscraper of today and the old building which stood until recently at the corner of Alamo Plaza and Houston Street in San Antonio, Texas. It was the first large office building erected in the city and when it was completed in 1886 was the most pretentious of the city's structures.

Its designer, while launching out boldly in emulation of the many-storied buildings which his contemporaries were erecting in the North, still clung to the traditional "gal-



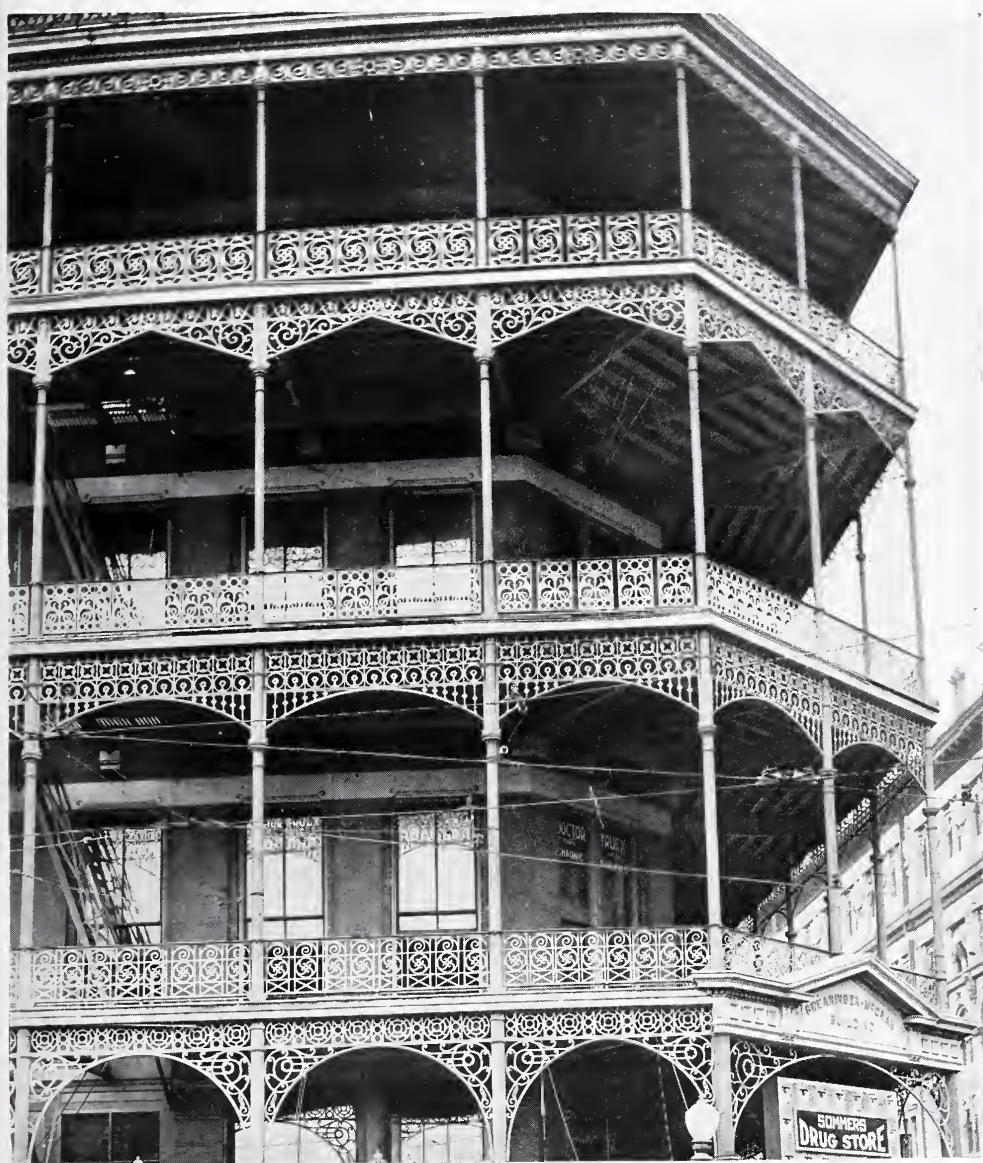

DETAIL OF IRONWORK—OLD MAVERICK  
BANK BUILDING, SAN ANTONIO, TEXAS.

leries" so characteristic of the architecture of the old South. The result was a five-story building typical of the time but enclosed by a nimbus of galleries.

Such a structure was essentially a product of the South, where the intense glare of sunlight rendered the deep shadows of the galleries most grateful, and the opportunities which they offered for quiet smokes and the discussion of cooling drinks in the intervals between financial transactions were doubtless relished by the ranchmen and cattlemen who made old "San Antone" their clearing house.

The many galleries of the old building were made doubly interesting by their elaborate ironwork, which was a distinguishing feature of the design, each story having an individual pattern.

Many of the details of construction are interesting as illustrating the progress in building made since 1886. Steel framework, reinforced concrete, hollow tile, etc., were of course absent; the building had timber framing, wood floors, lead water pipe, and other obsolete features.

A lover of the picturesque can not but regret the passing of this old structure, for it was an unique feature of a city that possesses much of artistic and historic interest. The quiet, easy going days have passed, even in the South, and the many-galleried buildings, which looked peacefully for so many years across Alamo Plaza toward the old mission buildings, must now make way for a successor more in harmony with the times.

I. T. FRARY.



OLD MAVERICK BANK BUILDING, KNOWN LATER AS SWEARINGER-McGRAW BUILDING, SAN ANTONIO, TEXAS.



10 cents a Copy

\$ 3.00 a Year

# The ARCHITECTURAL RECORD

December

1920

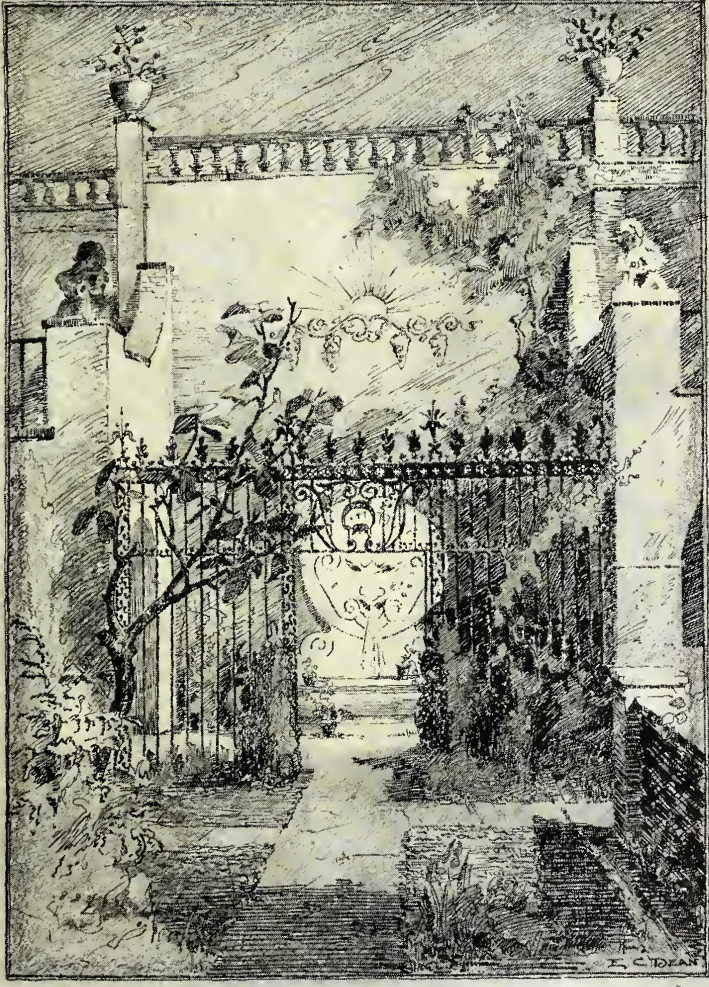

Published in New York



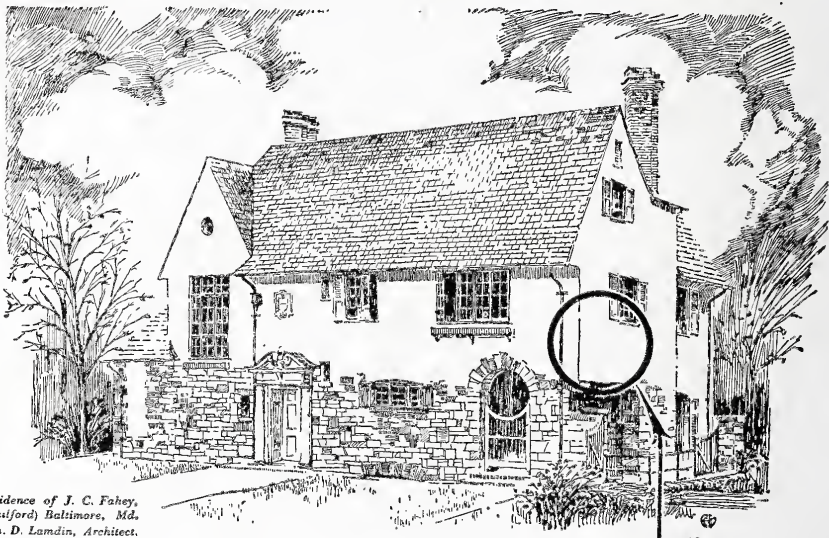

Residence of J. C. Fahey,  
 (Gulford) Baltimore, Md.  
 Wm. D. Lamin, Architect.  
 Bishopric Stucco Board used  
 on Exterior

# BISHOPRIC

## STUCCO AND PLASTER BASE

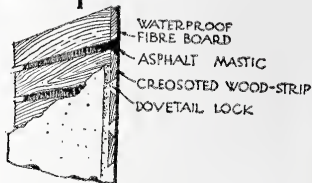

BISHOPRIC insulates against loss of heat by providing a dead air space in the construction. The asphalt mastic and the creosoted wood strips withstand DAMPNNESS and are WATERPROOF. BISHOPRIC insures PERMANENCE by reason of the dovetailed wood strips which clinch the stucco. BISHOPRIC is STRONG, having withstood tests. BISHOPRIC is RESISTANT against FIRE, VERMIN, DECAY, because of the nature of its material.

*A post card from the architect will bring him, "Built on the Wisdom of Ages," a booklet descriptive of BISHOPRIC with explanation of practical considerations, economic and labor saving qualities. It contains specifications for the use of BISHOPRIC stucco and plaster base and BISHOPRIC sheathing, which may be used as sheathing, as subflooring or roofing boards. The tables give weights and sizes.*



**THE BISHOPRIC MFG. COMPANY**  
 102 Este Avenue, Cincinnati, Ohio

Factories—Cincinnati, Ohio and Ottawa, Canada



# THE ARCHITECTURAL RECORD



CONTENTS

Vol. XLVIII. No. 6

DECEMBER, 1920

Serial No. 267

*Editor:* MICHAEL A. MIKKELSEN

*Contributing Editor:* HERBERT CROLY

*Business Manager:* J. A. OAKLEY

COVER—A Terminal Motif in Turtle Bay Gardens, New York City. Drawing by Edward C. Dean	PAGE
TURTLE BAY GARDENS, New York City. Edward C. Dean and William Lawrence Bottomley, Associate Architects <i>By Arthur Willis Colton</i>	467
THE VILLA PAZZI (La Vacchia), Pian de'Giullari, near Florence, Italy <i>By Harold Donaldson Eberlein</i>	495
THE EARLY ARCHITECTURE OF PENNSYLVANIA. Part I <i>By A. Lawrence Kocher.</i>	513
THE HOUSING SITUATION AND THE WAY OUT <i>By Lawrence Veiller</i>	531
DISPLAY ROOM OF THE ELLER MOTOR COMPANY, Cleveland, Ohio: Philip Lindsley Small, Architect	535
RECENT DEVELOPMENTS IN HOUSING FINANCE. Part II <i>By John Taylor Boyd, Jr.</i>	542
THE ARCHITECT'S LIBRARY	550
THE AMERICAN CHICLE COMPANY'S FACTORY, Long Island City, N. Y.: Ballinger & Perrot, Architects	553
NOTES AND COMMENTS	557

*Yearly Subscription: United States, \$3.00; Foreign, \$4.00; Single Copies, 35 cents. Copyright, 1920, by The Architectural Record Co. All rights reserved. Member Audit Bureau of Circulation.*

PUBLISHED MONTHLY BY

THE ARCHITECTURAL RECORD COMPANY

115-119 WEST FORTIETH STREET, NEW YORK

T. S. MORGAN, Pres. W. D. HADSELL, Vice-Pres. E. S. DODGE, Vice-Pres. J. W. FRANK, Sec'y-Treas.



LOOKING THROUGH ARCH OF LOGGIA TOWARD  
TERMINAL FOUNTAIN—TURTLE BAY GARDENS,  
NEW YORK CITY. EDWARD C. DEAN AND WILLIAM  
LAWRENCE BOTTOMLEY, ASSOCIATE ARCHITECTS.



# THE ARCHITECTURAL RECORD

VOLUME XLVIII



NUMBER VI

DECEMBER, 1920

## TURTLE BAY GARDENS NEW YORK CITY



*Edward C. Dean & William Lawrence Bottomley*  
*Associate Architects*

BY ARTHUR WILLIS COLTON

A COLLECTION of persons or families is neither suggestive nor progressive until it begins to be organic. It is not a society. We civilize each other in groups, but not in unrelated groups. Only as the separate persons or families begin to feel and be modified by each other does the social organism begin to stir, and only with this new life does the whole begin to show structure and design. There is no totality of effect, moral or aesthetic, out of a group of unrelated lives. They are chaotic like a heap of rocks, or monotonous like a stack of bricks, with hard, unblending surfaces; or like a checkerboard, or a sixteen square puzzle; or like the back yards of a New York City block.

The back yards of New York are star-

ing examples of the unloveliness of the unblended, where the human race proclaims itself to the compassionate heavens as divided into little repellent segments of existence. Each pushes its claims up to the last inch of the allowable, and there erects a high board fence. The whole block's meagre space of possible sunlight, grass and garden is marked off in harsh little squares of mutual dislike, barren, neglected and discouraged, or littered with rubbish, or decorated with clothes lines for the family wash.

Our street fronts tell much the same story of an unsocialized attitude of mind. Each house front proclaims its greed. It grasps all the space allowed it and rejects all friendship with its neighbors. It either copies their aspects with dull in-

difference, or looks as if it had violently quarrelled with them, or did not know they existed. There is no give and take between them.

The street front is individualism on display; but the back yard is its seamy side; and the sun, moon and stars, continually looking down, with whatever amusement or indignation, know what an appalling thing it is. If a young star asks of an elder, "Why are back yards so stupid and ugly?" the elder replies, "They are stupid, because they express their owners' indifference and ignorance of each other; ugly, because they express a mutual distrust or dislike. Monotony is the child of indifference, and ugliness of distrust. These cities, my inquisitive and hopeful starling, consist of a great many people jammed into a very small space, who wish for the most part to have nothing to do with each other and each to be a law to himself. How unlike our spacious order and our radiant peace!"

Turtle Bay Gardens on East Forty-eighth Street is one of several efforts, and perhaps the most successful, to meet

this superior criticism of the stars. Numbers 226 to 246 East Forty-ninth Street, and Numbers 227 to 249 East Forty-eight Street, were formerly a typical group of twenty houses owned by individuals. Such blocks and segments of blocks are too familiar for description. Either the old brownstone fronts repeat each other with dreary monotony, or (as in the kind of building that succeeded the brownstone era) each house on the street was designed without any relation to its neighbors. One house stood forward, the next was recessed, with different story heights, different scale, different widths. The brownstone fronts were tiresome, the later buildings restless and disquieting, and both were ugly.

This group has been remodelled and named Turtle Bay Gardens. It was found that the land thereabout had been called Turtle Bay Farm as far back as 1760, and that where the gardens now are (which were lately back yards) there ran, in the eighteenth century, a little stream called Turtle Bay Creek.

The façades on each street have been

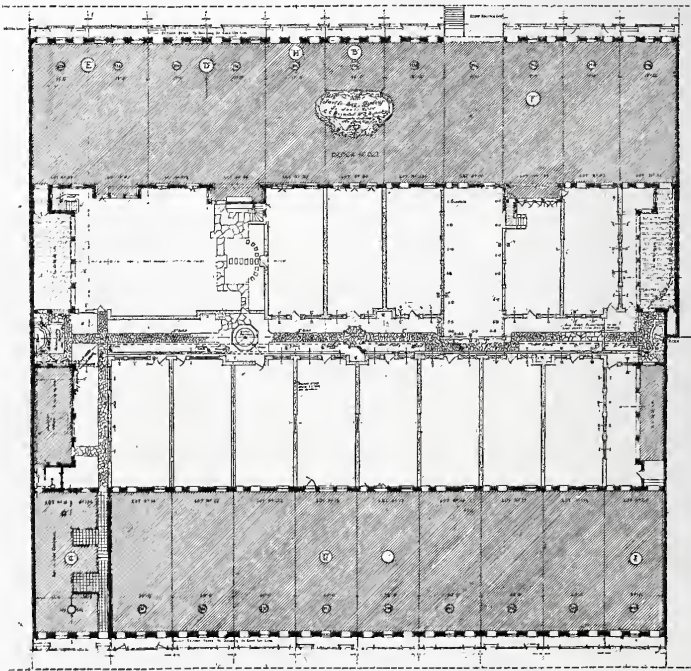

BLOCK PLAN—TURTLE BAY GARDENS, NEW YORK CITY.

Edward C. Dean and William Lawrence Bottomley, Associate Architects.





LOOKING TOWARD WESTERN END OF GARDEN — TURTLE BAY GARDENS, NEW YORK CITY. EDWARD C. DEAN AND WILLIAM LAWRENCE BOTTOMLEY, ASSOCIATE ARCHITECTS.



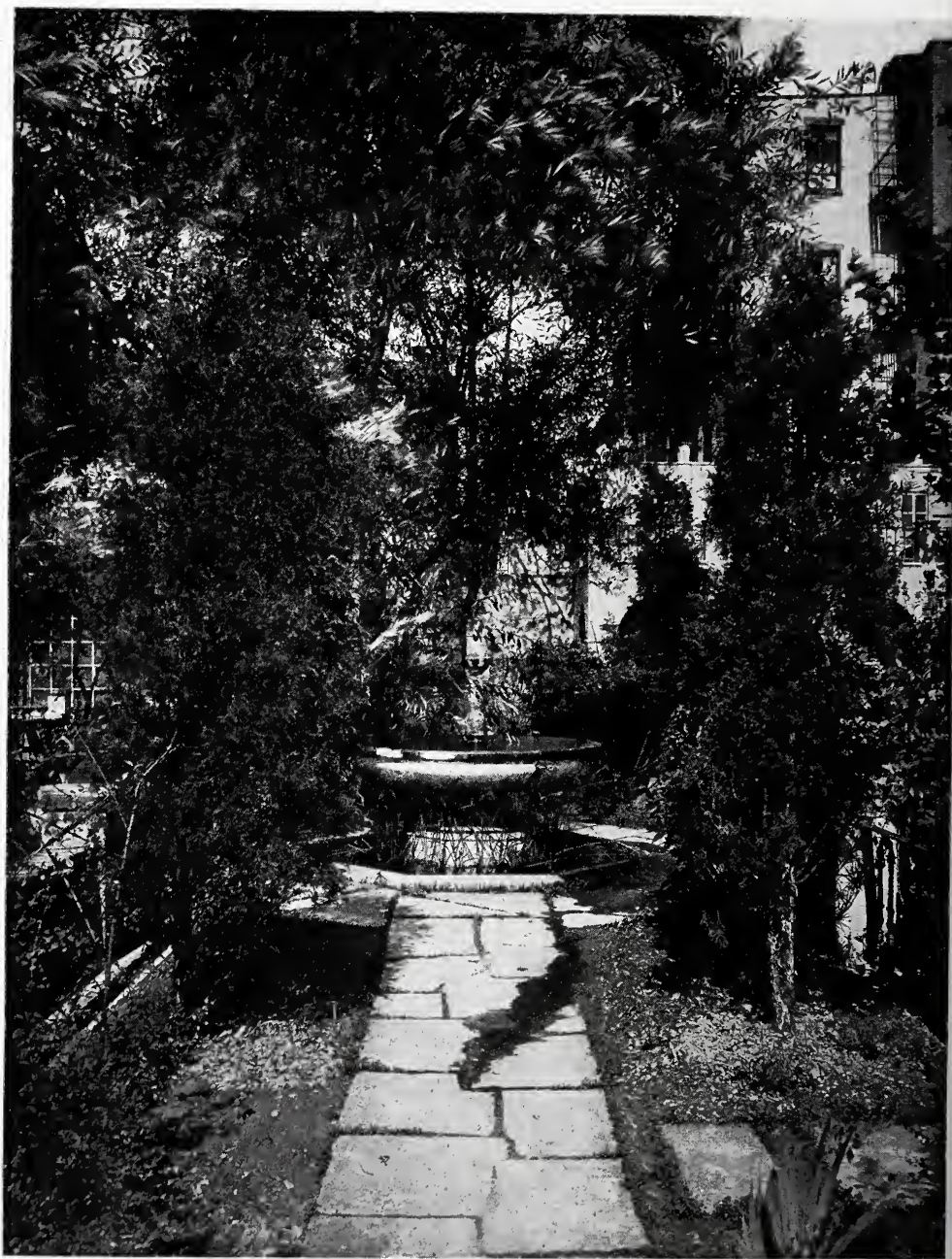

THE WILLOW FOUNTAIN—TURTLE BAY  
GARDENS, NEW YORK CITY. EDWARD  
C. DEAN AND WILLIAM LAWRENCE  
BOTTOMLEY, ASSOCIATE ARCHITECTS.



treated as a general composition, their color a warm limestone; the frames of their windows are painted black, the sashes a light cream color. The iron fences, and the gate posts with the turtles

tween them has been formed a large garden, 200 feet long by 100 wide, with a central path connecting all the individual gardens. These individual gardens are marked off by low brick walls, balustrades, low iron fences and gates; or in some instances they are thrown together. At each end are built loggias with terraces above, and rising behind the terraces a high wall pierced with grilled windows forms a decorative enclosing motive at each end of the garden, cuts off the views at either end down the block, and insures privacy. These walls are crowned with interesting pots of different designs, in which are planted small shrubs, ivies and flowering plants. An effort has been made to find variety in the different motives used, not only in these pots, but throughout the entire piece of work—in the fountains, color scheme arrangement of individual gardens, and in the placing of trees and plants and vines—and yet everywhere is felt the unity of the whole, the relation of the different parts. The general scheme is simple, but the detail is varied; and there is a wealth of it.

The paths are made of stone, laid irregularly, and with grass growing up between. The central path, extending from one end of the garden to the other, is well planted its entire length, and is finished off at either end by the wall formation spoken of before. This path ties all the parts of the garden together. It is common property of the owners. An arbor of stone columns covered with vines, around which is planted a circle of small crab-apple trees, forms the center motive, and a pergola with a fountain is built against the high terrace wall at one part.

One fountain, at the west end, is placed just back of a large alanthus tree. It is extremely simple, a dolphin spouting a jet into a small baroque bowl, which drips in turn into a basin flush with the ground. Above is an interesting treatment of great carved consoles, with an iron balustrade between pedestals and vases. The motives are treated so simply that they hardly can be called by their architectural names. The pedestals have no base, only a square mass of brickwork covered with stucco. There are no cap mouldings, only a rough stone cap. There



WALL FOUNTAIN ON THE CENTRAL WALK—  
TURTLE BAY GARDENS, NEW YORK CITY.

worked into the design, are a bright blue-green. The entrance doors are the same color, but lighter in value.

The façades are simple and restrained, indeed rather austere and formal, the idea being to make as strong a contrast as possible with the gay, informal and picturesque treatment of the garden façades. For it is in the treatment of the backs that the interest chiefly lies.

The houses are back to back, and be-



THE WESTERN FOUNTAIN AND ITS FLANKING TERRACES—TURTLE BAY GARDENS, NEW YORK CITY. EDWARD C. DEAN AND WILLIAM LAWRENCE BOTTOMLEY, ASSOCIATE ARCHITECTS.





THE LOGGIA ARCHES IN THE WEST END OF THE GARDEN HAVE THE DECORATIVE EFFECT OF A ROMAN AQUEDUCT—TURTLE BAY GARDENS, NEW YORK CITY. EDWARD C. DEAN AND WILLIAM LAWRENCE BOTTOMLEY, ASSOCIATE ARCHITECTS.





THE WILLOW FOUNTAIN—TURTLE BAY  
GARDENS, NEW YORK CITY. EDWARD  
C. DEAN AND WILLIAM LAWRENCE  
BOTTOMLEY, ASSOCIATE ARCHITECTS.





INTERIOR OF ONE OF THE LOGGIAS—  
TURTLE BAY GARDENS, NEW YORK CITY.  
EDWARD C. DEAN AND WILLIAM LAWRENCE  
BOTTOMLEY, ASSOCIATE ARCHITECTS.



INTERIOR OF ONE OF THE LOGGIAS LOOKING TOWARD VESTIBULE OF HOUSE—TURTLE BAY GARDENS, NEW YORK CITY. EDWARD C. DEAN AND WILLIAM LAWRENCE BOTTOMLEY, ASSOCIATE ARCHITECTS.





GARDEN FAÇADE OF FORTY-NINTH STREET HOMES  
FROM GARDEN WALK—TURTLE BAY GARDENS,  
NEW YORK CITY. EDWARD C. DEAN AND WILLIAM  
LAWRENCE BOTTOMLEY, ASSOCIATE ARCHITECTS.





FROG FOUNTAIN IN ONE OF THE PRIVATE GARDENS—TURTLE BAY GARDENS, NEW YORK CITY. EDWARD C. DEAN AND WILLIAM LAWRENCE BOTTOMLEY, ASSOCIATE ARCHITECTS.





SPANISH DETAILS OF THE GARDEN FAÇADE  
OF THE FORTY-NINTH STREET HOMES—  
TURTLE BAY GARDENS, NEW YORK CITY.  
EDWARD C. DEAN AND WILLIAM LAWRENCE  
BOTTOMLEY, ASSOCIATE ARCHITECTS.



DETAIL OF ONE OF THE FORTY-EIGHTH STREET HOUSES—TURTLE BAY GARDENS, NEW YORK CITY. EDWARD C. DEAN AND WILLIAM LAWRENCE BOTTOMLEY, ASSOCIATE ARCHITECTS.





DETAIL OF THE FORTY-EIGHTH STREET  
FAÇADE—TURTLE BAY GARDENS, NEW YORK  
CITY. EDWARD C. DEAN AND WILLIAM LAW-  
RENCE BOTTOMLEY, ASSOCIATE ARCHITECTS.

is very little architectural detail—few mouldings, few cornices. The effect is like an old Italian or Spanish garden more than anything else. Yet it is not any special style. It is new in its style and teaching, but old in its effect.

Near the central path, toward one end,

around the willow fountain. Note the interesting design on pages 474 and 486.

There is an abundance of pots standing in the garden on the low walls, on the loggias, on the steps leading up to the upper terraces. These pots are very decorative in connection with the garden. They



GARDEN FAÇADE OF HOUSES ON FORTY-NINTH STREET—TURTLE BAY GARDENS, NEW YORK CITY.

grows a fine willow, below which has been placed a fountain with the walk extending around it. It looks as if the willow had grown up over the fountain, instead of a new fountain placed under the willow.

At the northwest corner of the garden is a low, long pool with a jet of water at either end spurting out of a frog. Water cypress is growing in this pool and

give it a casual, a well used look. Some of them are plain red terra cotta, some marble; some have beautifully modeled garlands on them.

The treatment of the steps to the upper terraces is interesting. Steep, winding flights are built over arches springing like buttresses from the houses.

Very noticeable is the handsome foliage





GARDEN FAÇADE OF HOUSES ON FORTY-NINTH STREET—TURTLE BAY GARDENS, NEW YORK CITY. EDWARD C. DEAN AND WILLIAM LAWRENCE BOTTOMLEY, ASSOCIATE ARCHITECTS.

of the alanthus tree contrasted with the fine leaves of the willows and the heavy leaves of the polonia trees and gourd vines.

On this garden side the predominating color is apricot, a sort of rosy salmon pink—the color of the exterior walls of the

beautiful tones of the surrounding walls. The waterspouts to take the water from the roofs of the loggias are like gargoyles made of lead, with a curious spout almost like the bill of a duck coming out of a richly modeled rosette.

The fountain at the east end is a strong



BALCONY AND STAIRS OVER A GARDEN DINING ROOM—TURTLE BAY GARDENS, NEW YORK CITY.

loggias and terminal walls of the gardens—but some of the houses are painted a soft cerulean blue, others cream, buff and greyish moss green. The roofs are tile of a soft terra cotta color, varied with dark brown or almost black tiles, and a few of bright green. Both the foliage of summer and the bare branches and snow of winter are very fine against the brilliant and

contrast to the simple dolphin fountain at the west end. Here the wall extends to the height of twenty or twenty-five feet. At the base is an interesting baroque basin with a jet of water falling into it from a large, grotesque mask. At a great height above is a flat relief of the sun rising above a rinceau, treated in a conventional way with rays and hung with bunches of





FORTY-EIGHTH STREET FAÇADE—TURTLE  
BAY GARDENS, NEW YORK CITY. EDWARD  
C. DEAN AND WILLIAM LAWRENCE  
BOTTOMLEY, ASSOCIATE ARCHITECTS.



A LONG BAROQUE FOUNTAIN WITH A JET OF WATER AT EITHER END—TURTLE BAY GARDENS, NEW YORK CITY.

Edward C. Dean and William Lawrence Bottomley, Associate Architects.

grapes and grape leaves. In front of this fountain, and partially screening it, is a lacelike wrought iron grille extending completely across the space between the two loggias. An interesting gate leads into the court in front of the fountain, and above at either side are two small grotesque figures of cupids with vases. These figures, though small, are very heavy in scale. The heads are large, the features heavy; altogether they are ugly, but charming in their place. They have a sort of dwarfish look, like cluricauns in an Irish hedgerow. The view across the face of the loggias, with its succession of simple round arches, gives almost the effect of a Roman aqueduct.

Many of the houses have wrought iron balconies overlooking the garden. One balcony particularly is interesting. It is long and wide. Supported on eight

richly wrought brackets above are four light arches, above which are birds with dragons' heads. The color of the main structural lines of the iron work is black; the intermediate rods of the railings, the leaves and decorative volutes are a golden yellow, and there are a few minor accents of brilliant orange vermilion. This house with the balcony is a soft blue, and the middle awning above is Venetian red; the two side awnings a soft gold color with narrow borders of the same Venetian red.

In rearranging the interiors of the houses the service, delivery and kitchens were moved forward onto the street, with the dining rooms on the level of the garden at the rear. The principal living rooms are on the second floor at the rear. Some of the houses had another story added on the roof, containing a large liv-





GARDEN STAIRS AND VENETIAN LEADING  
—TURTLE BAY GARDENS, NEW YORK CITY.  
EDWARD C. DEAN AND WILLIAM LAWRENCE  
BOTTOMLEY, ASSOCIATE ARCHITECTS.





LOGGIA AT REAR OF ONE OF THE FORTY-NINTH STREET HOMES—TURTLE BAY GARDENS, NEW YORK CITY. EDWARD C. DEAN AND WILLIAM LAWRENCE BOTTOMLEY, ASSOCIATE ARCHITECTS.



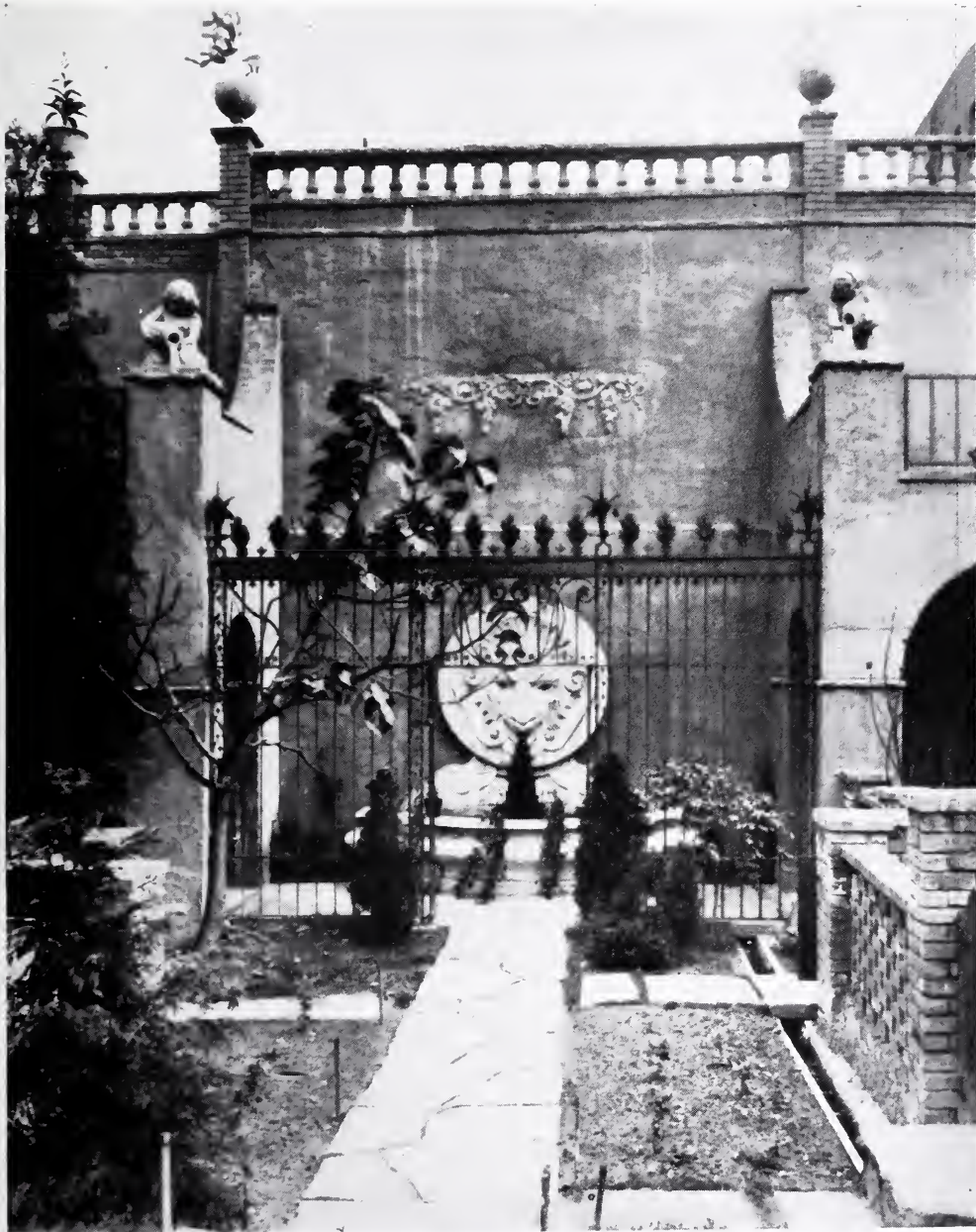

THE TERMINAL MOTIVE OF THE EASTERN END  
OF THE GARDEN—TURTLE BAY GARDENS, NEW  
YORK CITY. EDWARD C. DEAN AND WILLIAM  
LAWRENCE BOTTOMLEY, ASSOCIATE ARCHITECTS.



THE WILLOW FOUNTAIN—TURTLE BAY  
GARDENS, NEW YORK CITY. EDWARD  
C. DEAN AND WILLIAM LAWRENCE  
BOTTOMLEY, ASSOCIATE ARCHITECTS.





A GARDEN FAÇADE — TURTLE BAY  
GARDENS, NEW YORK CITY. EDWARD  
C. DEAN AND WILLIAM LAWRENCE  
BOTTOMLEY, ASSOCIATE ARCHITECTS.



DETAIL OF FORTY-NINTH STREET FAÇADE—  
TURTLE BAY GARDENS, NEW YORK CITY.  
EDWARD C. DEAN AND WILLIAM LAW-  
RENCE BOTTOMLEY, ASSOCIATE ARCHITECTS.



ing room or studio, with arcades and loggias looking down on the garden.

The great advantages of the scheme are: First, the unobstructed sunlight and air; for rear yard extensions are barred under the terms of the covenant agreed to in perpetuity by the owners. Secondly, the advantage of community service for sidewalks, furnaces, laundry work, care of windows and gardens, etc. Thirdly, the redemption of the ugly back yards into a beautiful, all the year garden.

The rear windows in New York usually belong to the less important and less attractive rooms. The old, dark kitchens, blanketed by a high extension, opened into unhealthy, damp back yards, with clothes flapping, and ill-kept wooden fences. In Turtle Bay the same rooms are transformed into bright, low-studded dining rooms with wide leaded casements—perhaps with a bay window flooded with sun and filled with growing plants and looking out into charming, sunny gardens. It is only a matter of changing some plumbing pipes, putting in larger windows—a few brick walls and some planting.

This same idea is now being used in two or three similar developments in New York, near the East river on Fifty-seventh Street, in Sixty-sixth Street and in Greenwich Village. One can but hope that it will spread like an epidemic. It is not likely that many interiors of residence blocks will have the charm of Turtle Bay, where the architects have been lavish of invention, and the attraction is not only of general design, but arises from the quantity of varied and sensitive de-

tail. Yet, if such a change should become general and the old back yard should vanish, the result would surely be a gain.

These are interests, of which each owner's share is increased by pooling. The economic saving is evident and familiar; but the aesthetic increment of the eye from one's window outlook is far greater still. The whole garden belongs to the windows of each of the twenty owners, and he most owns aesthetically this pleasant thing who can get most pleasure out of it. Even for an owner of good taste not much can be made of one back yard, but of twenty adjoining back yards can be made a Turtle Bay Gardens, when each owner has, visually speaking, surrendered a part and received back a beautified whole.

"Miller owns this farm, and Taylor that, but neither owns the landscape and horizon." Whether the quotation is from Emerson or Thoreau—and there lies only in my memory the impression that it is not accurately quoted—the notion is part of an argument that runs along with the whole philosophy of both of these, our American idealists, touching the free, unappropriated or common values of life. The usufruct of the eye is ideally socialized. Beautiful things suffer no wear and tear from our looking at them, nor lose any value to us if others see them too. The most personal and private possessions which the owners of Turtle Bay will enjoy in looking from their back windows are those for which they have not title deeds and which nevertheless are of all their possessions the most secure.



NORTH FRONT—VILLA PAZZI, PIAN DE'  
GIULLARI, NEAR FLORENCE, ITALY.



# THE VILLA PAZZI (*La Vacchia*), PIAN DE' GIULLARI. NEAR FLORENCE. ITALY



By *Harold Donaldson Eberlein*

THE Villa Pazzi, on top of the hill just above Pian de' Giullari, dates back from the fifteenth, or possibly in part from the fourteenth, century and incorporated even then, so the records seem to indicate, an earlier structure. In the fifteenth century it belonged to one Bartolommeo di Giorgio. From his heirs it went to Francesco di Antonio, whose widow, Lucrezia, daughter of Tommaso Petrucci, came into actual possession of the villa in 1528, when she had already married a second husband, Michele Del Cittadino. From the Cittadini it went to the family of Della Vacchia, who attached their name to the estate and seem to have made sundry enlargements. In 1673 the Samminiati bought the villa, and in 1760 it was passed by marriage into the Pazzi family.

The walls are salmon pink, the shutters are light green, the muntins are white, and the window and door trims are fashioned in *pietra serena*. The exterior aspect of the villa is unique, owing to the multi-colored majolica plates and platters set into the walls, affording spots of bright yellow, orange and green and deep blue. About a hundred years ago the then occupant conceived this novel method of augmenting color: interest and promptly put his unusual fancies into execution.

The ceiling of the large living room or *salone grande* is beamed, but what appear to be coffers are in reality pats of red velvet edged with gold braid and tacked on to the boarding. The walls are hung with red brocatelle. In the music room the brick floor is painted with a parquetry pattern in yellow and brown. The landscape paper in several tones of grey was put on the walls somewhat more than a hundred years ago; at the same time the beamed ceiling was painted in several tones of grey, the lozenge-shaped coffers being indicated on a flat surface, and the mouldings were painted on the flat surfaces of dados and window reveals. The hangings are of old golden yellow brocade.

The little walled garden, to the east of the house and the large garden, is a modern addition, but so carefully patterned after old precedents that it fits perfectly into the general scheme. The walk along the south front in the large garden is paved with slabs of grey stone, as is also the little kitchen cortile. In the large garden south of the house the extensive use of orange and lemon trees in pots will be noted, and it is this feature which imparts much of the interest.

The illustrations are published by courtesy of Charles Eyre, Esq.

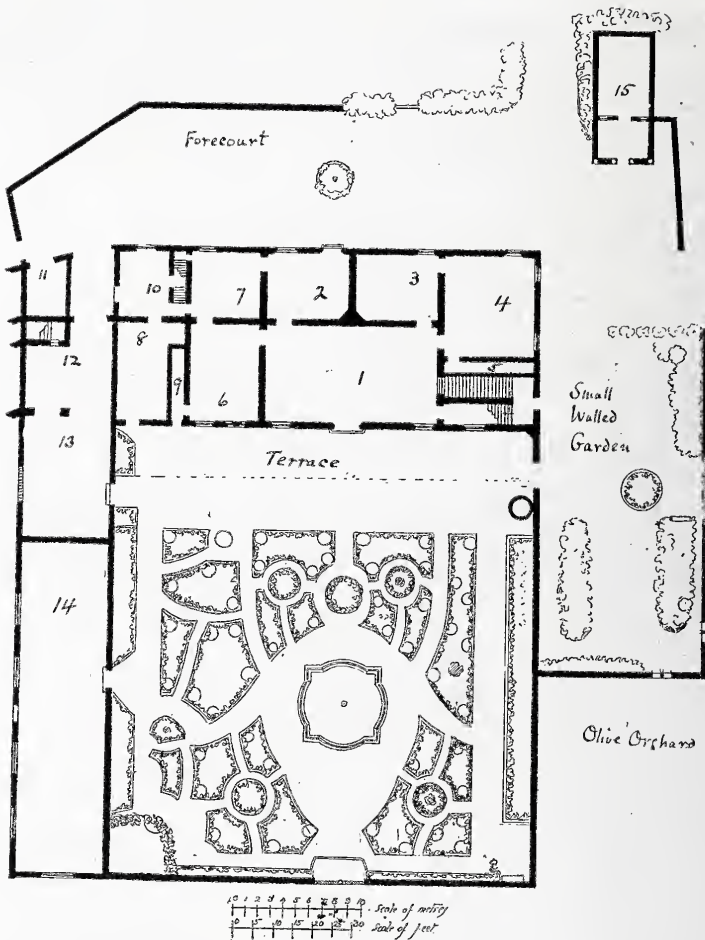

KEY TO GROUND FLOOR PLAN AND GARDEN PLOT OF THE VILLA PAZZI:

- |                                    |                         |
|------------------------------------|-------------------------|
| 1. Salone or Great Hall.           | 9. Bathroom and Toilet. |
| 2. Hall.                           | 10. Kitchen.            |
| 3. Study.                          | 11. Garage.             |
| 4. Music Room.                     | 12. Shed.               |
| 5. Cupboard for Coats, and Toilet. | 13. Kitchen Courtyard.  |
| 6. Drawing Room.                   | 14. Lemon House.        |
| 7. Dining Room.                    | 15. Chapel.             |
| 8. Pantry.                         |                         |

The buildings opening out beyond the garage are farm appurtenances and small rooms where the oil and wine are made. They do not form any essential part of the main villa, which is fully indicated on the accompanying plan.





NORTH FRONT—VILLA PAZZI, PIAN DE'  
GIULLARI, NEAR FLORENCE, ITALY.



NORTH FRONT—VILLA PAZZI, PIAN DE' GIULLARI, NEAR FLORENCE, ITALY.





HOUSE DOOR—VILLA PAZZI, PIAN DE'  
GIULLARI, NEAR FLORENCE, ITALY.

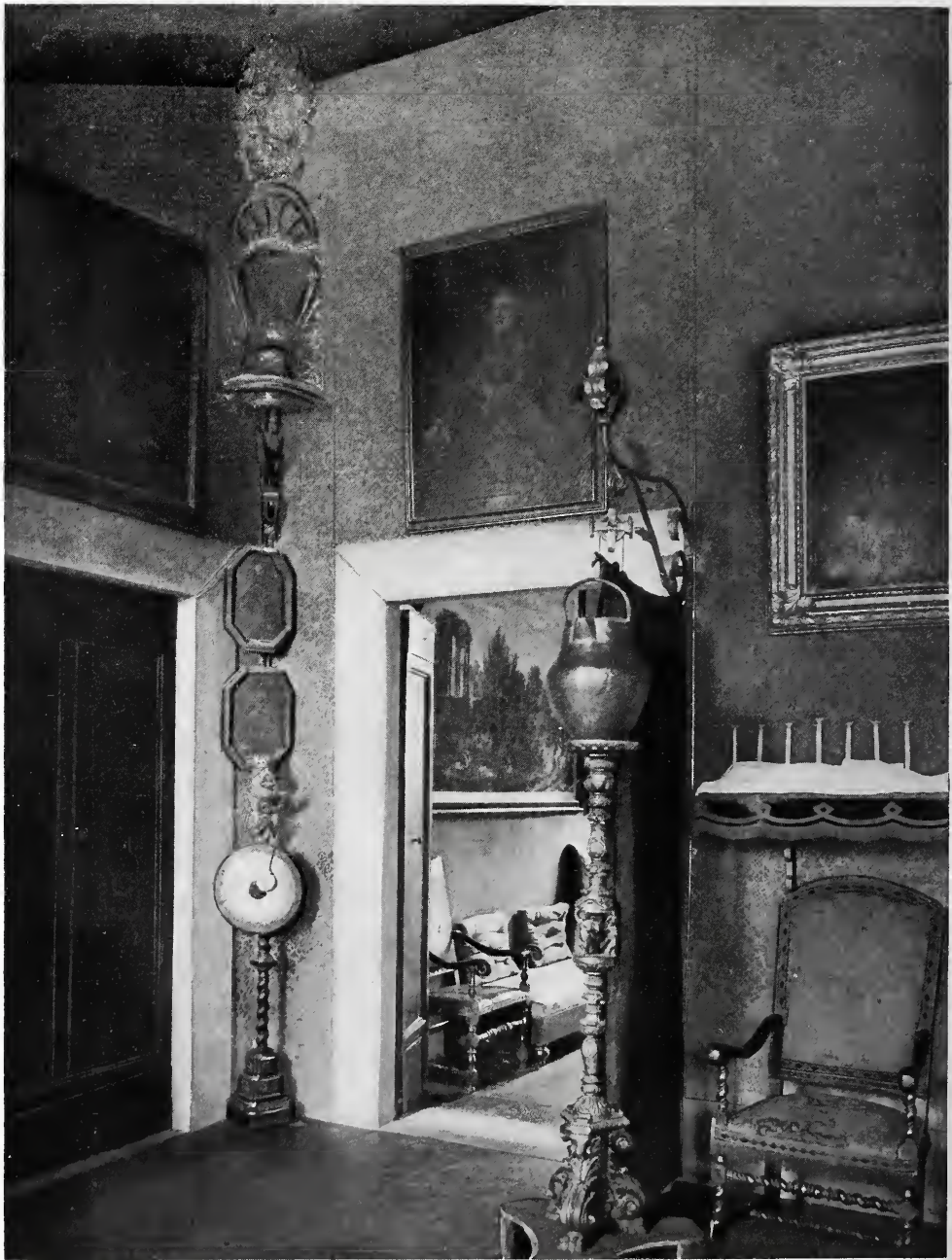

DOOR IN LIVING ROOM—VILLA PAZZI, PIAN  
DE' GIULLARI, NEAR FLORENCE, ITALY.





LIVING ROOM—VILLA PAZZI, PIAN DE'  
GIULLARI, NEAR FLORENCE, ITALY.



DOOR TO MUSIC ROOM FROM LIVING ROOM—VILLA PAZZI, PIAN DE' GIULLARI, NEAR FLORENCE, ITALY.





MUSIC ROOM—VILLA PAZZI, PIAN DE'  
GIULLARI, NEAR FLORENCE, ITALY.



MUSIC ROOM—VILLA PAZZI, PIAN DE'  
GIULLARI, NEAR FLORENCE, ITALY.





MUSIC ROOM—VILLA PAZZI, PIAN DE' GIULLARI, NEAR FLORENCE, ITALY.



SOUTH FRONT—VILLA PAZZI, PIAN DE'  
GIULLARI, NEAR FLORENCE. ITALY.





SOUTH FRONT—VILLA PAZZI, PIAN DE'  
GIULLARI, NEAR FLORENCE, ITALY.



SOUTH FRONT—VILLA PAZZI, PIAN DE' GIULLARI, NEAR FLORENCE, ITALY.



WALLED GARDEN—VILLA PAZZI, PIAN  
DE' GIULLARI, NEAR FLORENCE, ITALY.





WALLED GARDEN—VILLA PAZZI, PIAN  
DE' GIULLARI, NEAR FLORENCE, ITALY.





KITCHEN CORTILE—VILLA PAZZI, PIAN  
DE' GIULLARI, NEAR FLORENCE, ITALY.





END VIEW—GOVERNOR KEITH'S  
MANSION, GRAEME PARK. 1721-22.



# EARLY ARCHITECTURE ~ OF PENNSYLVANIA ~

By  
A LAWRENCE KOCHER

*With Photographs by Frank Cousins, J. Horace M<sup>rs</sup> Farland  
and Others, and with Measured Drawings by the Author*

## PART I

THE story of the early architectural development in Pennsylvania has been but partly told. Various accounts have considered the wealth of architectural material in the vicinity of Philadelphia, but no one has recorded the examples or described the character of the architecture within the broad confines of the State. So rich is Philadelphia in noteworthy specimens that it may seem needless to comprehend a territory in which, because of a sparse and scattered population, a somewhat more humble array of Colonial monuments occur. And yet from the point of view of the present-day architect, it is the country that affords the greater inspiration for modern building. It is the small dwelling and the farmhouse, rather than the city residence or public building, that furnishes the most fruitful model to our designers. It is also to the humbler buildings that one must go in order to trace the traditional growth of an architecture. The individual examples may be of but slight importance, but, considered as a group, they take on a new significance, producing a background in the evolution of the more conscious architecture and completing the chain of development from the primitive to the developed form.

A feeling of hearty respect for the traditional architecture of our country was never more clearly in evidence than at the present time. We look with reverence upon the local styles that were evolved in colonial and early federal days, when buildings were conceived by local men and built with local materials. We recognize a rich heritage of such early buildings, which are only now being completely

appraised. We are being continually surprised at the number and the quality of new specimens that are being brought to the light of publicity by the press and by exhibitions. The time has come when the older sections of our country should be made the subject of such a careful and thorough investigation as the Royal Commission on Historical Monuments made in England; and the inventory should be published as a service to the profession, and as an acknowledgment to our own people of the worth of ancestral architecture.

In the eighteenth century in Pennsylvania a style of architecture was developed which is distinguished for its individuality, its singular beauty, and its variety. It was favored by nature in the possession of an abundance of timber, clay and good building stone; and consequently a native architecture was created in which traditions were modified and frankly adapted to local conditions. "What is there in the United States," asks Mr. Ralph Adams Cram, "more charming as an expression of vital architecture than the dwellings and barns of the vicinity of Philadelphia? Frank and simple in form, the texture and stone are fine to a degree, while there is that wonderful quality of picturesqueness that is almost wholly absent from similar work in New England and the South. A spacious and noble dignity, high-bred and aloof, is characteristic of the latter; delicate and sensitive detail, the mark of the former; but of picturesqueness of composition and charm of texture and color there is almost nothing in either."

Pennsylvania was the most favored

and prosperous of all the American colonies. From the time William Penn with his band of English Quakers settled upon the Delaware in 1681 until after the Revolution, there was a continuous growth in material prosperity. It was the last of the colonies founded under the Stuarts and it consequently profited by the mistakes of the London Company in Virginia and of the Plymouth Company in Massachusetts. The settlement of Pennsylvania occurred when the most adaptable and, in many respects, the finest of English architecture under Queen Anne and the Georges was produced. The lateness of the age and the lessons of the neighboring colonies shortened, for Pennsylvania, the period of primitive beginnings, and almost immediately dwellings of respectable pretentiousness were raised on estates in eastern Pennsylvania.

In considering the development of the early architecture of Pennsylvania, there are three main divisions, three groups of facts to be dealt with: (1) the first attempts at building by the pioneers who by force of circumstances were impelled,

for the most part, to create their motives; (2) the mature architecture introduced by English workmen, modified by original tendencies of the pioneer age; (3) the Federal Period, when, under conditions of self-government, both dwelling houses and public buildings took on a monumental and more purely classical character.

These three divisions are definite and clearly recognized. The first is of short duration, a time of pathetic groping in the dark, but important in giving a local turn to the developed architecture of the second phase. The second division includes all building efforts, possessing style, erected within the dates 1720 and 1800. Here is to be found all those buildings which are characterized as "Pennsylvania Colonial." Outside the group are peculiar and irregular tendencies, to be attributed to various racial attributes, which will be referred to in considering the racial elements of the style.

In the beginning it was difficult for the followers of William Penn to cultivate the arts and the soil at the same time. The circumstances under which the colonists found themselves were unnatural



A PENNSYLVANIA BARN, GRAEME PARK, MONTGOMERY COUNTY, PA. 1801.





Copyright photo by H. W. Fegley.  
THE MOUNCE JONES HOUSE, BERKS COUNTY, PA. 1716.

and abnormal. While they were subduing the wilderness and laying the foundations of a government, it was not to be expected that they would erect buildings of so refined a nature as they were accustomed to in the old world. The arts would not flourish until after the conquest of brute nature had been achieved, an assured government established, and the growth of wealth and consequent leisure had produced the favorable conditions to foster the humanities.

Cut off from the main stream of the true and accepted architecture, the builders found it necessary to bring into being their own architectural vocabulary, or by recollection to reproduce the art of the mother country.

It is worthy of note that the building style as first established by the early Pennsylvania settlers bore only a slight resemblance to that of the countries from which it came. The men who had crossed the seas and changed their sky inevitably found their method of working modified. The strange conditions met in Pennsylvania, the changed man-

ner of living, and the new materials that were available caused a reforming of their ideas of construction. Their houses and public buildings came to be unconscious expressions of the new conditions, colored by their new living; and the results at first could scarcely come under the exacting term "architecture."

Writers on architecture have generally disregarded this pioneer period in colonial America. And yet it was during the episode of struggle that original tendencies were brought to the surface, when the features of the regional style, which were to become so characteristic, were evolved. Had the home-seekers of Pennsylvania been spared the initial years of almost complete isolation, had there been no time when the necessity existed for creating shelters, however crude, then no distinctive architecture could have resulted. A transplanted European way of building would have followed, or methods of building commonly practised in the European countries, represented on this side of the Atlantic, would have been practised. In

either case local and evolved features would have been lacking.

The impress of the pioneer building upon later work is not found so much in specific details which persisted, as it is in the naïve character and provincial originality which resulted from the work done in an independent fashion and from the acquiring of a knowledge of the possibilities of certain materials, such as wood and stone and brick. Also, because of necessity, the craftsmen were forced to experiment. In this way they produced mutations of arrangement and design. Some features, however, did remain over from this pioneer time. The use of the pent-roof, known today as the Germantown hood, is an instance. This pent-roof was first used between the first and second story of the log-house, and was intended to protect the chinking of the log walls from being washed away by the beating rain. It is quite probable that this was a German device, as it is to be found on many buildings of the Germans. Postlewaite's Tavern, which is illustrated on the opposite page, had such a protecting roof. The building was erected near Lancaster in 1729 and is still in existence, although modified by the addition of clapboarding.

In the more permanent architecture which followed, this detail continued as an element of design, even though the walls of later architecture are of brick or stone. Residence work of today, especially in the vicinity of Philadelphia, has adopted the hood as a part of many a country and city dwelling.

It is not altogether fanciful to suppose that other features adopted in subsequent design and construction may have had a similar primitive beginning: such as the popular adoption of the roof with end gables, the occasional persistence of exposed ceiling beams, the simple rectangular outline of plan, and an almost general use of shutters. (Shutters very rarely appear in English design.)

These first essays in building, then, are not to be classed as architecture, for true architecture has its inception in beauty as well as usefulness. True architecture, however simple, breathes a charm or gives a pleasure. The first

efforts failed to attain such standards. There was too much of the dire need of hasty and sure protection from the Indian and the weather to give play to the promptings of the artistic instinct. The first attempts at building were, therefore, of the undeveloped, necessitous sort. As in literature we have a time of story telling around the frontier camp-fire before works of literary art are composed, so also there exists a chapter of fundamental beginnings in building. Both are episodes in respective branches of art.

Almost the complete list of noteworthy colonial and early federal buildings in Pennsylvania are included within the years 1720 and 1820. That was a time of economic prosperity featured in an unexampled growth of commerce, in the opening of rich mines, in the development of fertile farm areas, and in the flourishing of industries. The growth of wealth gave rise to a well-to-do leisure class with cultivated tastes. The population had increased by leaps and bounds until the province, founded in a small way as a "holy experiment" and as a religious refuge, had outstripped the sister colonies of the North and South. In 1765 Pennsylvania boasted the greatest number of inhabitants. Philadelphia before the Revolution had become the greatest city in the country in population and importance, and we are told "no other city was so rich, so extravagant, so fashionable." "Travelers from distant lands," says MacMaster, "were most impressed by the fineness of the houses, the



ANGLE VIEW OF EARLY LOG HOUSE, SHOWING "CHINKING."



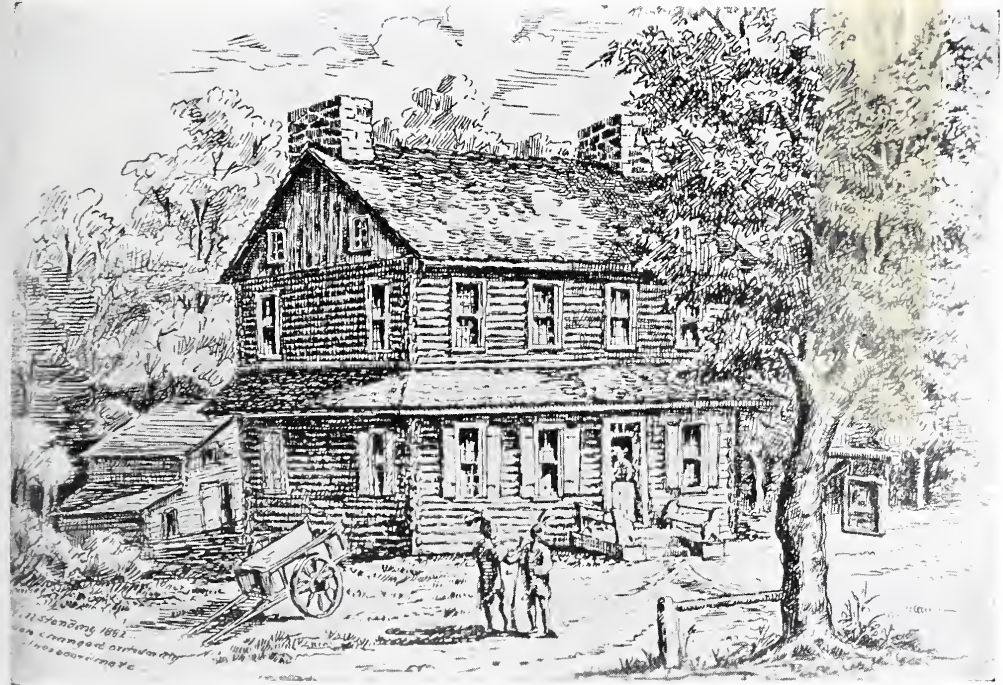

POSTLEWAITE'S TAVERN, NEAR LANCASTER, PA. EARLY USE OF PENT-ROOF. 1729.

goodness of the pavements and the filthiness of the carriage-ways." It became the custom of wealthy citizens of Philadelphia to build elaborate country-seats, such as Graeme Park, Mount Pleasant, Cliveden and Stenton, which, in excellence of design and splendor of setting, rivaled the contemporary estates in England. The English Georgian architecture of the eighteenth century contributed largely to the formation of the architecture of the colony; but it was modified, as we will note, by local peculiarities.

The British Isles were in the midst of a classical revival. The style initiated by Wren and Inigo Jones was being changed and refined by Italian influences. Hawksmoor, Gibbs, Kent, Campbell and the Adam Brothers were the architects of the century. Books of "The Orders" and "Handbooks of Architecture" were published by many of the men. It was a time when the art of building was being popularized in England, when a knowledge of architecture was deemed an essential in the education of a gentleman. Many of these handbooks found their

way to the colonies and were generally used as a guide. The vogue of these books meant that any one with reasonably good taste could design a house and that, by following rules, his proportions would probably be pleasing. Carpenters and certain of the educated class alike are to be given the credit for the design of the buildings of that time.

A traveler in the colony in 1765, Nicholas Pickford, relates in his diary that he is amazed at "the goodness of the buildings in Philadelphia." "The gentlemen, so it seems, have for the most part some considerable aptitude in architectural matters. Indeed, by many of them it is held an essential part of a gentleman's education that he should know enough of Architecture to form thereof an intelligent judgment and, if it be necessary, to devise and direct such building as he may have occasion to engage in. . . . However, when I call to mind the understanding interest in Architecture shown by many of our gentry at home, and when I also consider how all the peoples of the Colonies, so far as I

have observed them, do hold straightly to the ways of the Mother Country, I can see why so much good Building hath been achieved."

One should not assume that the buildings of Pennsylvania were exact copies of these English works. The architecture thus inspired was adapted to new needs, and changes were freely made and details altered by the use of wood. Buildings were lengthened, stories added, a doorway or modified roof included to serve a use and to increase the pretentiousness of a structure. That originality was freely drawn upon is shown by the variety of buildings erected, no two of which have been found to be identical. On the other hand, that they are derived from a similar source is attested by the general resemblance that pervades their physical appearance. The isolation and the absence of architects trained in the old world tradition were in themselves

virtues, for they contributed to the free interpretation of classic proportions.

The first evidence of an adopted style, regularly practised, does not seem certain to have occurred before 1720, when appeared the ornamented wood cornice, the studied and symmetrical disposition of the façade, the paneled interior walls and stairways. Columns, pilasters and entablatures were soon added to the builder's stock in trade. The rectangular plan with the central hall and with the kitchen projecting to the rear to form an "ell" was characteristic, although variations are met with, in which the entire floor arrangement is included in a block plan or with end projections. The hipped roof with low pitch was used on country residences about Philadelphia, where English traditions were always most closely adhered to. The gable-ended roof of the pioneer days continued on certain city residences and became an



THE BILLMEYER HOUSE, GERMANTOWN, PA., SHOWING USE OF PENT-ROOF. 1727.



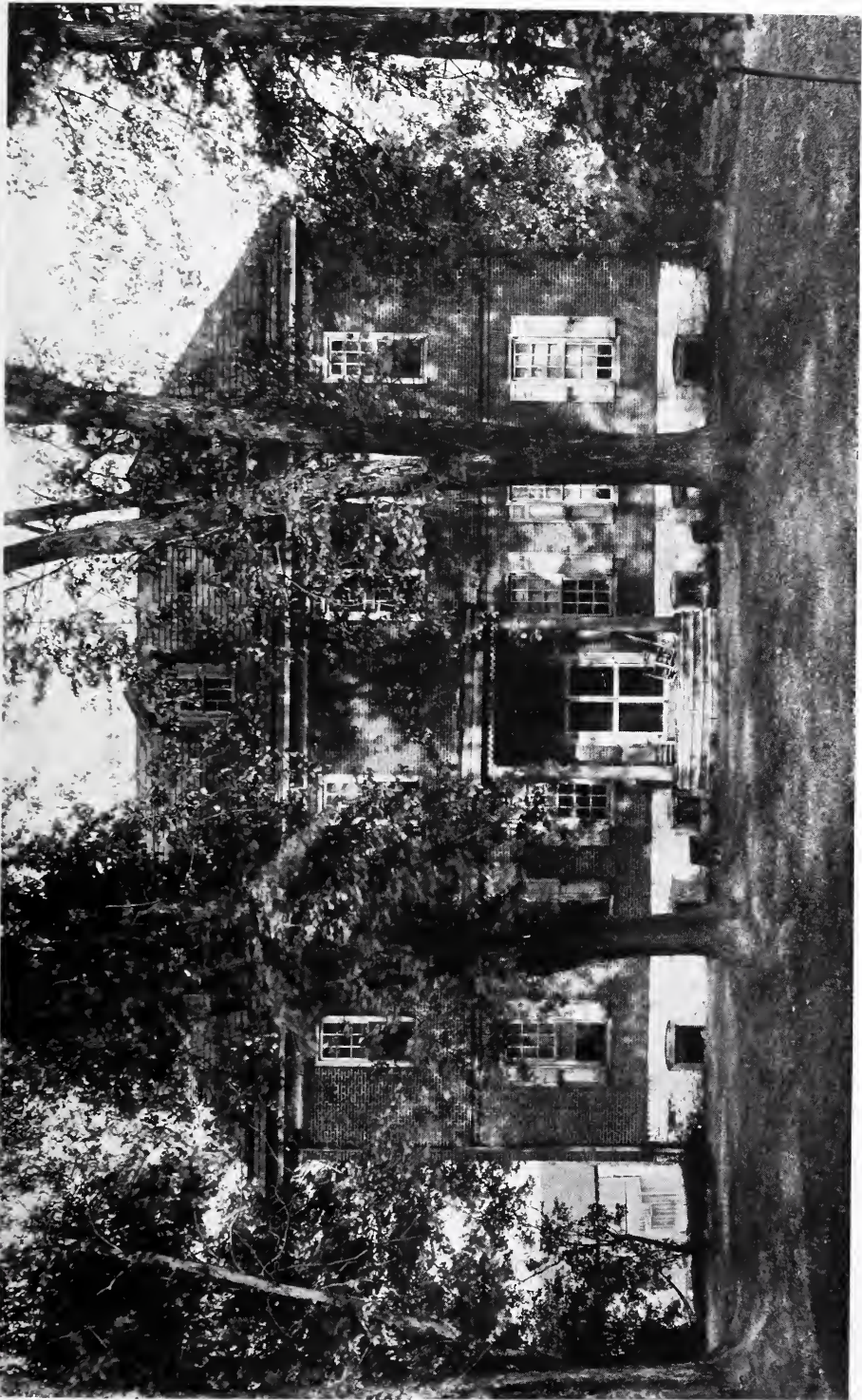

HOPE LODGE, WHITE  
MARSH, PENNSYLVANIA, 1723.





THE TOM MOORE HOUSE, NEAR CARLISLE, PA.



THE WRIGHT HOUSE, WRIGHT'S FERRY, PA.





THE JOHN BARTRAM HOUSE,  
PHILADELPHIA, PA. 1731.



MACLAY MANSION,  
HARRISBURG, PA. 1790





DOORWAY OF R. CURTIN  
HOUSE, BELLEFONTE, PA.

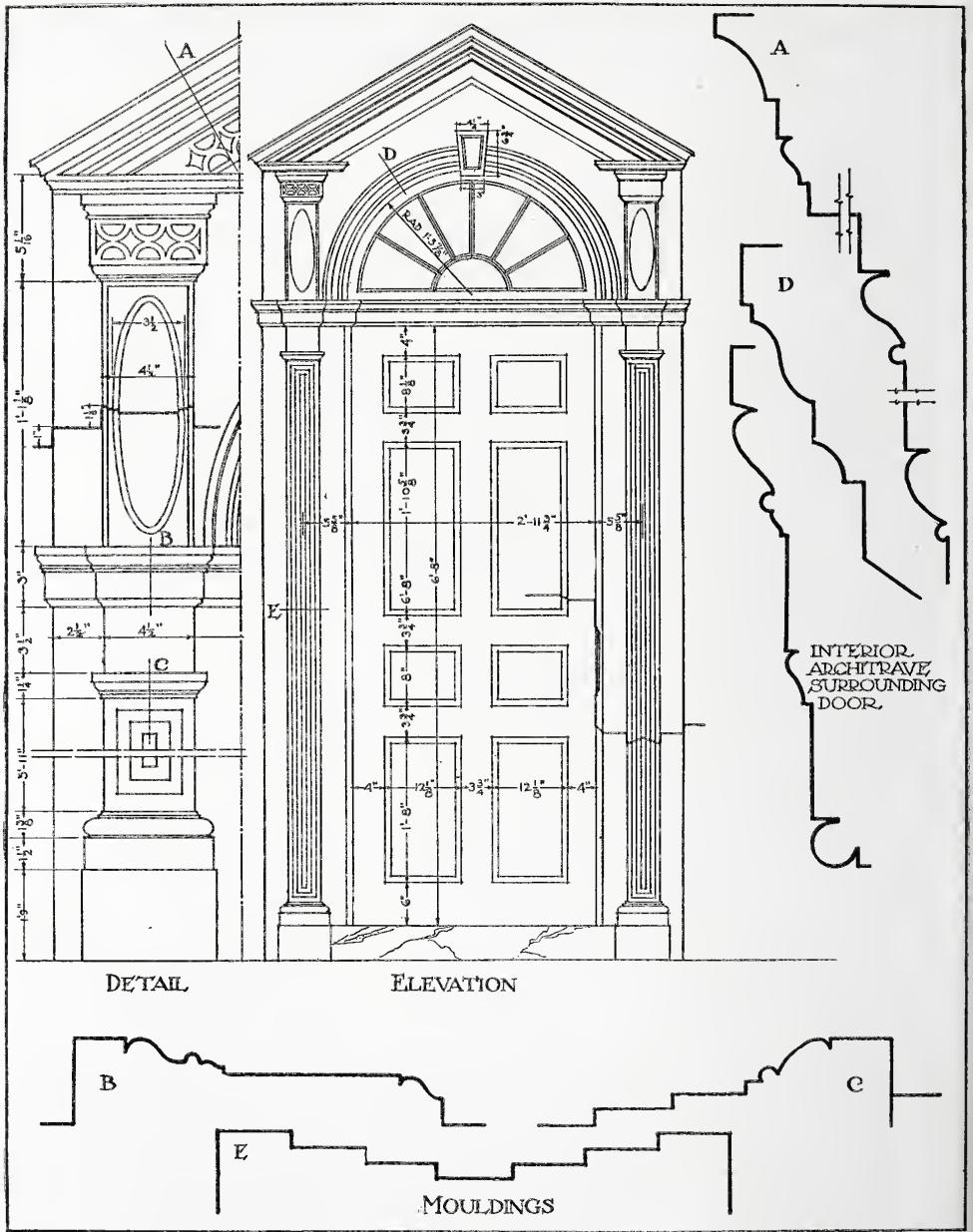

INTERIOR  
ARCHITRAVE  
SURROUNDING  
DOOR.

DETAIL

ELEVATION

MOULDINGS

DOORWAY OF R. CURTIN HOUSE, BELLEFONTE,  
PA., 1804. MEASURED AND DRAWN BY A. L.  
KOCHER, ASSISTED BY LIEUT. E. C. SEIBERT.



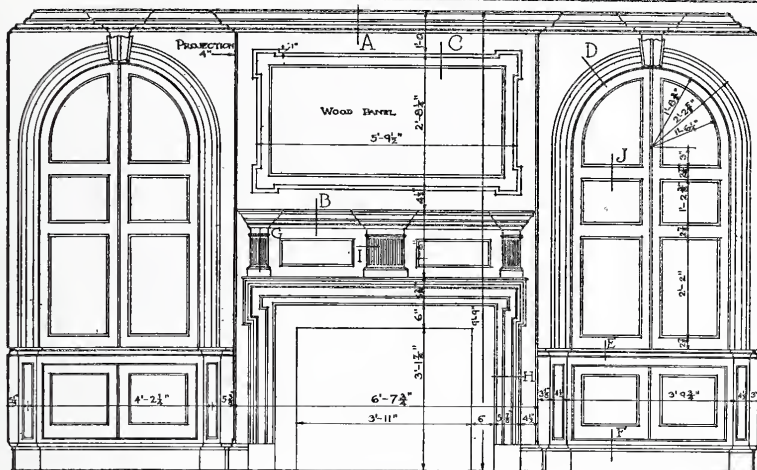

ELEVATION

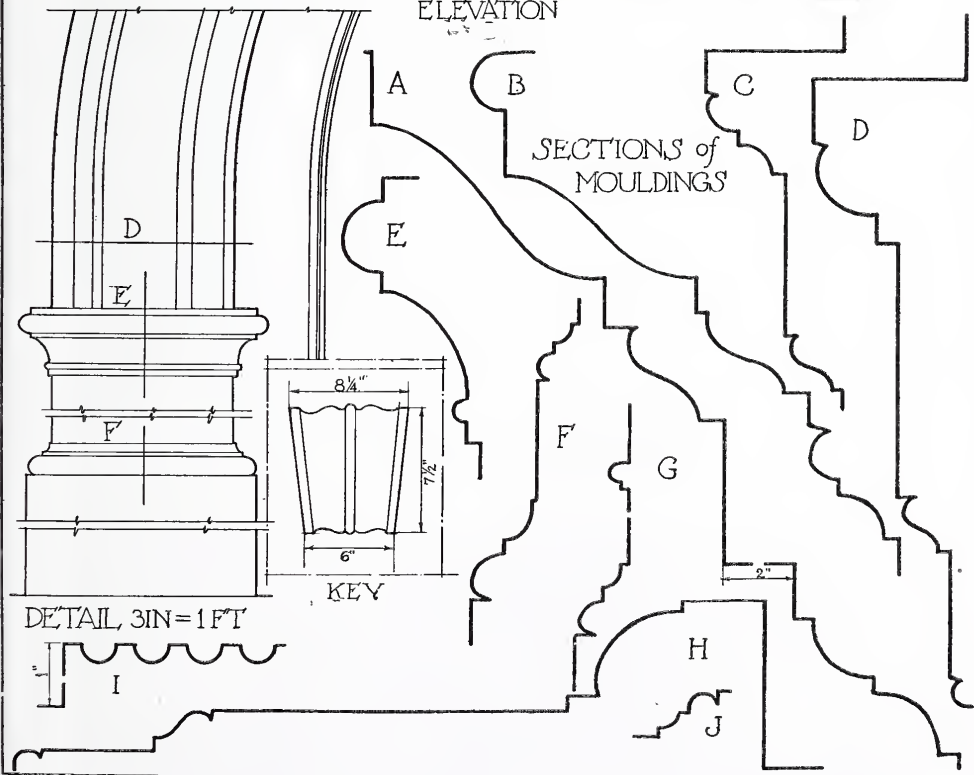

MANTEL AND WALL TREATMENT—LINDEN HALL TAVERN, LINDEN HALL, PA. BUILT ABOUT 1800. MEASURED AND DRAWN BY A. L. KOCHER.



THE WOODLANDS,  
PHILADELPHIA, PA., 1770.





DETAIL OF PEDIMENT—THE WOODLANDS, PHILADELPHIA, PA. 1770-72.



LOUDON, NEAR WAYNE JUNCTION,  
PA. BUILT BY THOMAS ARMAT, 1801.





BANK OF THE UNITED STATES (CUSTOM HOUSE), PHILADELPHIA. BUILT 1819-27 FROM DESIGN OF BENJAMIN LATROBE.

ever present part of the Pennsylvania farmhouse. The rare use of wood for outside walls in a region that had been so thickly forested is noteworthy. The materials commonly used were brick and stone; the two were sometimes combined with stucco. Records and the evidence of buildings indicate a preference for brick in Philadelphia, where clay-pits were known from an early date; and there was a prevailing use of stone in the outlying and inland districts.

By the middle of the eighteenth century the projecting central bay or pavilion, crowned by a pediment, appears on certain country houses of eastern Pennsylvania, of which Mount Pleasant Mansion in Fairmount Park may be taken as an example. The Palladian window on the second story is frequently combined with this treatment and is probably an imitation of a similar arrangement made popular by the old State House of Philadelphia. The pilastered doorway with slight projection and usually surmounted by a pedimented hood appears so frequently as to be the rule. In certain rare instances, and then only in late examples, the two-story porch was featured: for example, the Woodlands in Fairmount Park and Loudon in Germantown.

Skill in craftsmanship advances with the century. The growing excellence of moulded and carved woodwork reflects a fuller architectural knowledge—a knowledge developed in shops of special craftsmen in Philadelphia and influenced by models brought from England.

The ingenuity of the builders of the eighteenth century was largely concentrated on the dwelling house. It was necessarily so in a new land, where shelter was the prime requisite. Several churches and public buildings of the first importance were erected. The design of these buildings partakes of the domestic, perhaps because of the better understanding of this phase of the builder's art.

The American Revolution, with the changed conditions arising from the newly attained independence, gave rise to what became in effect an architectural revolution. It would seem that the new nation, in the midst of new problems of large scope, felt the need of giving expression to the new national life. The revision in attitude was not sudden, but gradual, and did not show tangible form until about 1800.

The changed order in architectural matters in the first half of the nineteenth century is clearly a reflection of the national ideas of the times. A realization of federal power, an independence from British ideas, a reaction against provincialism, a desire to compete with the European in dignity and importance—all these things were unconsciously expressed in the changed works. Buildings assume a new importance by becoming more monumental, design becomes literally classical, the humbler building materials are discarded for cut and carefully finished stone. The art of building passed from the craftsman and fell into the hands of the trained architect.

In Pennsylvania, Benjamin Latrobe was the leader in the new era. He began with the erection of the Bank of Pennsylvania in Philadelphia in 1799, in which he made use of the free-standing Greek Ionic order in an open portico. He later adopted the pure Greek in the Bank of the United States, in the same city, modeled after the Parthenon with eight Doric columns. It remained for his pupils and followers, Robert Mills, William Strickland and Thomas U. Walter, to carry the new movement to a full triumph with the original design for the Harrisburg Capitol, the Philadelphia Mint and the Merchants' Exchange. In certain districts the old ways lingered, but only for a short time. The Greek Revival became paramount.



# The HOUSING SITUATION AND THE WAY OUT

*By*

LAWRENCE VEILLER

*Secretary of the National Housing Association*

FROM every part of the country there comes the cry of no houses for the people to live in. How great the shortage of homes really is no one knows. It has been estimated at from one million to three million.

Serious as the shortage undoubtedly is, there are no cities where the people are shelterless. One sees nobody sleeping in the streets or parks, and so few cities where people are living in tents, that where this situation exists it is a matter of widespread comment.

What has happened is that families have doubled up so that two homes now grow where one grew before.

Even in this respect the country is without authentic or accurate information. No one knows to what extent this practice exists. And yet the facts are ascertainable without great difficulty or expense, for every city possesses a police force and a health department, and a census of such double occupancy could quickly be taken.

Moreover, a paramount obligation rests on the health authorities of every city in the country to know the facts in this regard, as overcrowding holds a menace to the health of the country.

While sanitarians and scientists have been slow to admit any direct causal relation between bad housing conditions and disease generally, it has been scientifically demonstrated and is now accepted doctrine that between room-overcrowding and certain "contact infections" there is a very clearly established and direct causal relationship.

The epidemics of influenza and infantile paralysis which but a few years since swept this country and left in their trail

death and misery are, I hope, not so remote as to be entirely forgotten.

Are we so foolish as to think these will not return? Were they to return now, they would find in the conditions of crowded occupancy of homes that exists all over the country a fertile field for their rapid development.

It is a real menace which confronts the country. Those health officers who sit supinely by and do nothing about it have a heavy burden on their souls. The U. S. Public Health Service should be alert and sound a call of warning to the health officers of the country, but no sound comes from Washington. Has the sleeping sickness of officialdom swept over them?

The situation holds a menace to the social order as well. Promiscuity is bound to result in lax relationships, in loosely held marital ties. The Health Officer of the City of Cleveland has stated recently that the returns of the first six months of the current year (and these are incomplete) show in his city alone an increase of 50 per cent. in illegitimate births, which he ascribes to the promiscuous living conditions that exist, caused by the shortage of houses.

The shortage of homes is having a serious effect upon industry. Plant extension is crippled, the development of new industries is discouraged, and the difficulties of living engendered by dwelling in crowded quarters is being reflected in the shop. How far the bad temper resulting from this is responsible for the industrial discontent and low productivity now so manifest, it is difficult to say. That it is an important factor there is no gainsaying.

The effect of the house shortage that is most felt by the public is undoubtedly the economic one. For to that cause the public attributes the increase of rents which is so general throughout the land.

This situation which exists in all parts of the United States is due chiefly to the fact that since the war the building of dwelling houses has almost ceased. As a matter of fact, for several years before our entry into the war, production of dwellings had greatly diminished.

As illustrative, one may cite the fact that though it is stated that there were 1,040,000 marriages in the United States in 1919, there were only 70,000 new dwellings completed and only 20,000 the year before. Generally, for each marriage that takes place a new dwelling is wanted.

The chief reason why the production of dwellings has ceased, as every one knows, is that they cost so much to build and that therefore there was no market for them—they were beyond the purchasing power of those for whose occupancy they were intended.

In this respect the United States is in no sense peculiar. The situation is a universal one. Practically every country is similarly situated. From the Antipodes to far portions of Africa and Asia as well as throughout all Europe a similar situation exists.

The methods adopted of meeting this situation in the United States are radically different from the methods adopted throughout Europe. There, where government housing and government-aided housing have been in practical operation for many years, the natural thing to do has been to place chief reliance upon the Government in the present difficult circumstances and new government-housing schemes have been and are being elaborated. In most European countries the private builder in the housing field is as extinct as the dodo. The economic consequences of such methods, as exemplified by England's imposing on her taxpayers a *loss* of one hundred million dollars (\$100,000,000) every year for a

period of 60 years, we have pointed out in a previous article.\*

The method of handling the situation in America thus far has been a *laissez faire* policy; a policy of "watchful waiting" for prices to come down, for conditions to right themselves. The country has had before it so terrifying an object lesson of what government operation has meant through the operation by the Government of the nation's railway system, at the colossal loss of over thirty-eight million dollars (\$38,000,000) a *month*, that it has much preferred to do nothing and to suffer the consequences of crowded living for a while longer rather than embark on so economically unsound and hazardous a project as government housing.

There are two radically different conceptions of government. One, which we may perhaps best describe as the German one, looks to the State as the source of all power, and conceives it to be the duty of the State paternally to take care of its citizens, to provide them a living.

The other conception of government is that which we have hitherto liked to describe as the American one, and which holds *that* country governs best which governs least. It is postulated upon the theory that man progresses best when he stands on his own feet and gets what life has to offer for him through his own industry, intelligence, thrift and ability.

This may be old-fashioned doctrine, but we hold fast to it. We believe that democracy is better than socialism.

While we thus say that men should stand on their own feet, the situation is different when we see a man, walking on the seashore, sink into a quicksand; we do not then conceive it to be helpful to shout out to him that he should stand on his own feet—instead we summon the neighbors, rush to his aid and with planks pry him out.

Is not the country as a whole in that situation so far as housing is concerned? And if the country *has* sunk into a quicksand, how can it get out unaided, and who is to help it out?

\*See Architectural Record, November, 1920



The chief cause for the cessation of house building, as we have already pointed out, is the high cost of building. The three basic factors that enter into that cost are money, materials and labor.

Up to the present the attention of the country has been concentrated almost solely on methods of cheapening the cost of money; of making investment in house-building attractive once more to capital. Laws have been proposed, and in some States enacted, exempting such investments from mortgage and income taxes; others have exempted all new dwellings constructed in the next three years from local taxes for a fifteen-year period; while still other proposals have sought to compel by law insurance companies, banks and trust companies to invest a certain proportion of their funds in dwelling house mortgages.

Little or no consideration has thus far been given to the equally important factors in the high cost of building, namely, materials and labor.

I venture to say that were unlimited funds, even at comparatively low rates of interest, made immediately available for house construction, few houses would be built.

For, not only is the cost of building materials prohibitive at the present time, and that in the face of a minimum demand for them, but all intelligent observers agree that with the increased demand for materials that will come when building operations start up again, building material prices will begin to skyrocket.

The moment one begins to take up either stabilizing or reducing the cost of building materials, one is at once confronted with two factors in the situation which seem to be controlling. These are coal and transportation. If the manufacturer of burnt-clay products has to pay exorbitant prices for fuel, can there be any doubt that these prices will be reflected in the cost of his product?

If a specific building operation is held up for months, eating its head off in interest-carrying charges, because it is waiting for a carload of sash or nails or doors or something else essential to the operation, is there any doubt what effect such delays will have on the ulti-

mate cost of the operation? If freight rates and demurrage charges on building materials are unduly discriminatory, is there any doubt what the effect will be on the cost of building?

We leave out of consideration those corrupt practices, conspiracies in restraint of trade, to keep up prices of materials and stifle competition that have been disclosed by the recent legislative investigations in New York.

And what of labor? If unlimited funds should be made available for house building, if prices of materials should be reduced or stabilized, would the construction of dwellings be resumed, unless labor's attitude could be made clear?

No intelligent person will invest his money in house building so long as this uncertainty exists. A house estimated to cost \$6,000 may actually cost \$8,000 before it is finished if labor starts the practice of "snowballing"—rolling up prices through successive strikes—or protracts the time of construction through a policy of "ca' canny," or restriction of output. If American bricklayers should follow the example of their English brethren and limit each man's daily output to 300 bricks a day instead of 750 bricks (the pre-war output in England; 1,200 to 1,500 in America) the cost of construction would be increased 25 per cent.

Is there any doubt that the country, as to housing, is in the quicksands up to its armpits?

What forces are there strong enough to pull the country out? We have tried a *laissez faire* policy for the past two years and the country has sunk in deeper and deeper.

Reluctantly I am forced to the conclusion that there is no help for it but to invoke the assistance of the Government. No other agency is powerful enough to grapple with the situation. For it means fixing and stabilizing, for a given period at least, the prices of building materials and building labor, as well as coal; and the control and the direction of transportation.

Not until that is done can we expect investment funds to return to dwelling construction. And when that is done, without probably the necessity of any

special tax exemption, capital will once more seek these channels of investment. For the need of the country is great and industry is vitally affected by the present situation. With the uncertainty of cost of construction removed and prices stabilized, there is no reason why the country should not be restored to the pre-war basis, and the construction of dwellings be resumed once more by the initiative of private enterprise.

I do not wish to be misunderstood. I am not advocating either government housing or government-aided housing. I believe both to be unwise and undesirable.

What I am advocating is that the Federal Government should take hold of the housing situation; should realize that the country is in a quicksand as to housing, and that it must be helped out.

Repugnant as the creation of additional governmental bureaus is, I fear there is no help for it, and that a new bureau must be created in some one of the great government departments, charged with the sole duty of grappling with this situation. No one of the existing departments of the Government seems especially fitted for it. Perhaps the new Department of Welfare, which President-elect Harding is pledged to create, might be a suitable place for it. No question affecting the public welfare could more profitably occupy its attention.

Irrespective of where such a bureau may be located or how it may be constituted, the task which confronts it is to sit down with the producers of those building materials that enter into the construction of dwellings and make agreements that will fix the price and produce the supply of such materials needed by the country, if the shortage of dwellings is to be caught up with in a reasonable time.

This is no easy task. There must be a recognition on the part of the Government that these business men are not only entitled to a fair profit, but must be given sufficient incentive and insured against loss, if they are to produce the materials that the country needs.

Nor can any such arrangement be expected unless the Government can similarly stabilize the labor cost of these manufactured products. No manufacturer could make such agreements otherwise.

That this is not at all impossible to accomplish is borne out by the example of England. In that country the Government said to the makers of brick, we will guarantee to use so many million brick if you will produce them at such and such prices. The manufacturers of brick agreed, and seven hundred and fifty million (750,000,000) brick were thus produced, at a saving of 50 per cent. over what they would have cost the country by the usual method. A similar course was followed with many other articles that enter into the construction of buildings. That is what we propose should be done in America.

In similar fashion we would have the Government sit down with Labor and make similar agreements for the labor cost of handling such materials in the erection of the dwellings that the country needs. And here, too, of course, the terms would have to be fair and offer attractive returns to the worker.

Much could be accomplished by such a government bureau through persuasion and fair dealing and an appeal to patriotism, but undoubtedly it would have to be armed with the power of compulsion, to be employed where persuasion failed.

It would, moreover, have to be equipped for the difficult task of untangling transportation snarls, and seeing to it that after materials were produced they could be got where they were needed without undue delay or expense.

While such a bureau should be a temporary one, it would probably take it several years to complete the services to the country for which it was created. That such services can be rendered only through federal action must be obvious upon the slightest consideration. Involving as they do the control and direction of transportation, to deal adequately with the situation transcends the ability of the State or the City. The country is still in the quicksand.



# DISPLAY ROOM OF THE ELLER MOTOR COMPANY CLEVELAND, OHIO

*Designed & Decorated by  
Philip Lindsley Small, Architect*

**I**N Cleveland, Ohio, may be seen a new automobile display room of very unusual merit. It belongs to the Eller Motor Company, and both the architectural design and the design of decoration is the work of Philip Lindsley Small. The quality of the work seems to bear out a statement made in a recent article in the *Architectural Record* by Mr. John Taylor Boyd, Jr., to the effect that a room, in which the architecture, the furnishings and the embellishments are the creation of a single designer, is apt to be a better achievement than a room in which the treatment of these several elements are intrusted to different designers.

The scheme of arrangement was worked out on the idea that there are three general divisions to the business transacted in such an establishment, namely, the display of the automobile, the intimate routine business of the officers and salesmen, and the place where the salesman and the prospective buyer confer. The showroom proper is entered through a vestibule of paneled oak and leaded glass doors. It is long, high-ceiled and flooded with light from plate-glass windows which reach from floor to ceiling. At the rear is an arcade, in

which are placed long oak tables, richly covered chairs, telephones and writing materials. Here the public and the salesmen meet to transact business. In the wall behind each arch of the arcade are groups of leaded glass casement windows and doors leading to the various offices occupied by the salesmen and officers of the company. The spirit and atmosphere of this general scheme hark back to certain medieval market places.

In the rear of the offices, and almost as large as the showroom itself, is the general office, extending to the public space along the side street. This space connects the showroom in front with the service station in the rear and gives access to the parts department, service foreman, cashier and general office.

The color scheme of the showroom is soft and warm, accented by rich color in tapestries and in the upholstery of chairs, by the old rose and gold worked into the wrought iron stairway, ceiling clusters, and wall lights, and by pongee silk hangings at all windows and doors. The effect is very charming and restful to the eye, and serves as an admirable background and foil to the polished bodies of the automobiles on display.

The treatment is a noteworthy departure in display room design.

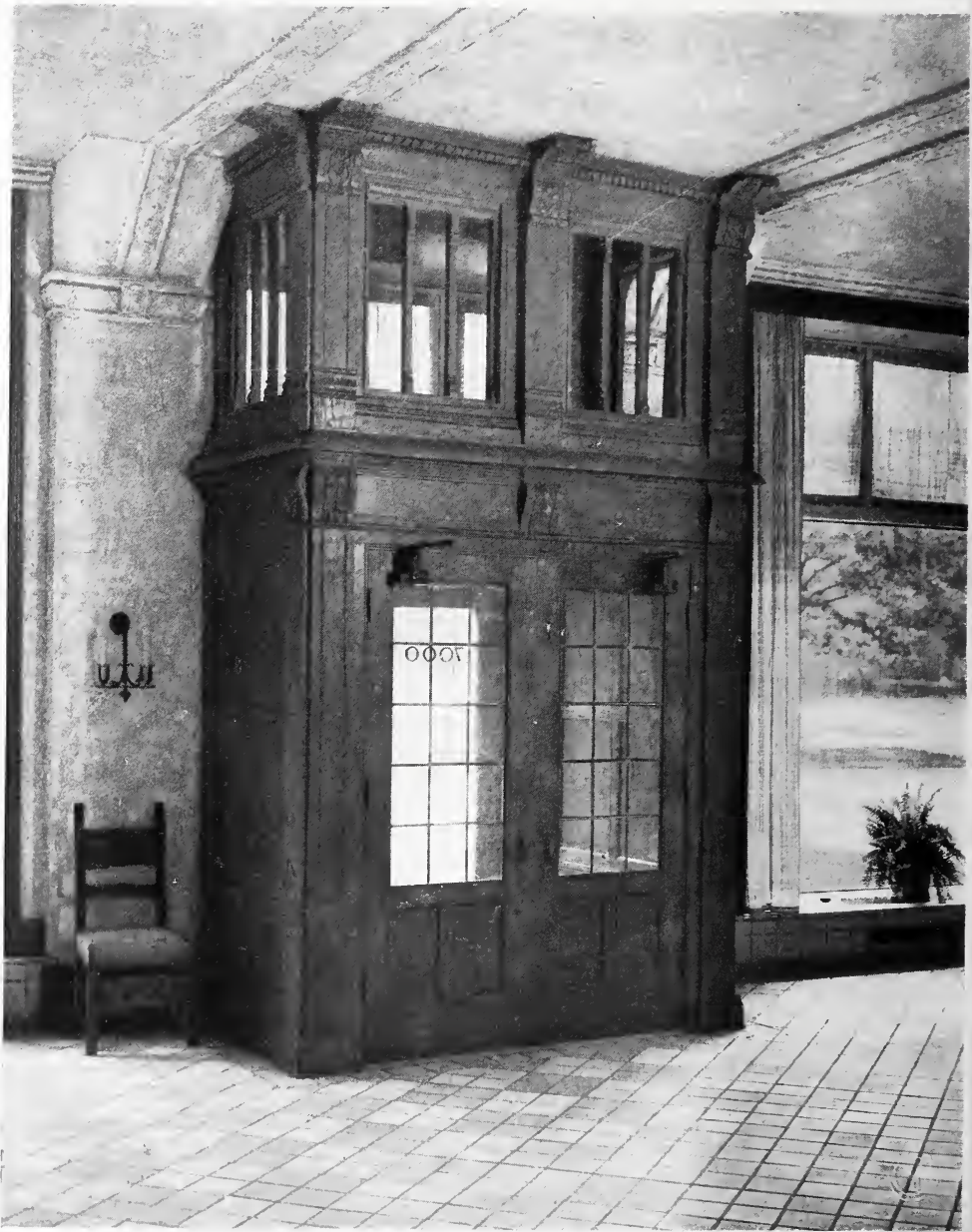

ENTRANCE VESTIBULE—DISPLAY ROOM OF  
THE ELLER MOTOR COMPANY, CLEVELAND,  
OHIO. PHILIP LINDSLEY SMALL, ARCHITECT.





MAIN SHOW ROOM, LOOKING WEST — DISPLAY ROOM OF THE ELLER MOTOR COMPANY, CLEVELAND, OHIO. PHILIP LINDSLEY SMALL, ARCHITECT.



LAMPS AND RAILING ARE IN ANTIQUE WROUGHT IRON  
—DISPLAY ROOM OF THE ELLER MOTOR COMPANY,  
CLEVELAND, OHIO. PHILIP LINDSLEY SMALL, ARCHITECT.





STAIRWAY TO UPPER SHOW ROOMS AND OFFICES—  
DISPLAY ROOM OF THE ELLER MOTOR COMPANY,  
CLEVELAND, OHIO. PHILIP LINDSLEY SMALL, ARCHITECT.



ARCADE, SHOWING ENTRANCES TO OFFICES—DISPLAY ROOM OF THE ELLER MOTOR COMPANY, CLEVELAND, OHIO. PHILIP LINDSLEY SMALL, ARCHITECT.





ARCADE, LOOKING EAST TOWARD STAIRS—DISPLAY ROOM OF THE ELLER MOTOR COMPANY, CLEVELAND, OHIO. PHILIP LINDSLEY SMALL, ARCHITECT.

# RECENT DEVELOPMENTS IN HOUSING FINANCE



By



JOHN TAYLOR BOYD, JR.

~ PART II ~

THE preceding article described those fundamental relations between buyer and seller which underlie the deed of sale. The neglect of the human factor is the weakness of most older practices in housing finance. Because it has not understood the conditions of modern society—what impels people to rent instead of own their homes—housing finance has failed to cope with the extraordinary growth of tenantry in the United States in the last thirty years. Today the majority of Americans are renters.

This failure is disastrous, and one may think that it makes housing finance the weakest link in housing. However, the rapid progress in other fields of housing; the splendid standards which have been established in the design of the individual home; in group neighborhood and community planning; in building construction; in operation and management—all this enterprise offers hope of a corresponding improvement in finance.

Now, although the technical details of the sale plan are important, they will not suffice of themselves. Here again we have an important truth, and it cannot be emphasized too strongly. The essential is the soundness of the houseowner's investment in his home. If a product is to be sold at any time in a long course of years it should be a durable product; its value should be safeguarded in every possible way; and, it should have a good, steady market. If you advise a man to invest most, or all, of his savings in a home—perhaps going into debt for it—and he asks you what will be the selling value of the house five, ten, thirty years from now, what can you tell him? Can you assure him, honestly, that real estate is habitually financed on a secure, long term basis; that

the neighborhood values are protected from sudden depreciation caused by entrance of factories or other types of buildings; that reckless speculation causing cycles of shortage and over-production of houses is unknown? Questions such as these, I fear, would embarrass the boldest real estate salesman.

It seems idle to expect to establish good standards of housing finance unless real estate be placed on a time investment basis and, as much as possible, taken out of the market of trading and over-speculation, which so discredit it now. To some people this may seem like asking too much. We are so accustomed to current real estate practices in small house financing that we do not realize that better methods are possible. The success of the older building and loan associations was due to their integrity, and the new finance corporations are operating precisely because they can in a measure overcome these financial weaknesses of temporary value and insecurity. It should be realized that real estate speculation is left over from the pioneer period of development of the United States, in which initiative and risk were essential in order to establish towns and make them grow. But now that we are settling down to more permanent communities we need to plan our financing on a permanent basis. Housing experts are complaining of the increasing failure of real estate mortgages to compete with the "gilt-edged" securities in Wall Street. But I am inclined to think that the competition of such securities may, in the long run, be a benefit; that for unsound practices in real estate finance there is no cure like the threatened competition of the stocks and bonds of the Pennsylvania Railroad.

Of course, in the matter of quick and



profitable sale, stock market securities always will have certain advantages over real estate. So, also, may real estate have values peculiar to itself. But, without pursuing this point further, one may conservatively assert that housing finance should rest on a secure, long-term investment basis as far as possible.

In attaining this object of placing home owning on an enduring financial basis, three essentials must be sought for, as mentioned above. One is the value of the home as an individual product; the second is its value as a part of a fine, permanent neighborhood, and the third is a fair market, reasonably stabilized against the ruinous effects of "booms." By these means the house, considered as a financial asset, will be safeguarded against influences which threaten quick depreciation of its value.

Proceeding to these three kinds of safeguards, the first concerns architecture and building construction. In order to gain enduring value in a house it should be designed after high standards of planning, appearance, operation and economy. Standards of house design have made great progress in recent years, particularly since the war, and architects with any knowledge of housing know what they are. The point here to note in relation to finance is that these standards are rapidly improving. This, in business terms, means that houses tend to become obsolete more rapidly than formerly. They lose value unless they are designed in the most up-to-date way and, if possible, with some imagination as to what progress will cause people to expect of a house in ten or twenty years.

The types of houses which seemed efficient, economical and liveable thirty years ago are no longer so today. Older houses, even if they have been kept in perfect repair, do not bring so much money when sold as formerly, because their type does not attract. There have been great strides in planning. Around New York, for instance, it has been remarked that architectural design, however crude, has real estate value in the small house market. Those little houses which can boast of even a draughtsman's touch on roof or porch or entrance bring more than those

which show no attempt at artistic proportions.

Construction, as well as architecture, deserves a brief word. People learned with automobiles that first cost is not the whole cost, and they are beginning to learn this truth in respect to houses. Mounting costs of construction, the costs of repairs which mean expensive hand labor, the fact that, even in first cost, temporary construction in recent years has been approaching permanent construction—these facts are gradually forcing us toward fire-resisting construction, which is also permanent construction, requiring little or no repair. There is no better illustration of this principle than the action of the United States Bureau of Internal Revenue, which allows a "life" of twenty-five years on frame buildings in figuring real estate items in income tax returns. This means that, for a frame house costing \$10,000, \$400 should be set aside each year to cover repairs and obsolescence.

But a house, no matter how well designed and soundly built, has no great financial value in itself, if the neighborhood values are not sound and permanent. This is perhaps the greatest obstacle in financing housing today. In many towns and cities the home owner still has no protection against those sudden shiftings of business and industrial centres, characteristic of American communities, that are so disastrous to real estate, particularly to small house values.

In order to safeguard property values in a neighborhood, private restrictions are not sufficient in most cases. Zoning alone can cope with this evil, and it is good to see it spreading to other cities since New York City adopted this principle in the law of 1916, as the only sure way to protect the real estate market from chaos. Even so, zoning is only one of the safeguards which may be thrown around the neighborhood, and I may only mention "supporting" values of comprehensive planning, such as efficient street and transportation systems; correct placing of factory and commercial centers, parks, playgrounds, schools, churches, etc.; together with some mitigation of reckless land speculation which fixes excessive capital costs on real estate, and, finally, some

means of discouraging real estate booms—those causes of fluctuation in value. All these safeguards will protect neighborhoods against rapid depreciation and obsolescence, and will go far to eliminate all but legitimate risk in home ownership.

All this discussion of fundamental principles of value in housing is intended to bring out the truth that, if the policy of owning homes is to be approved as an American tradition, it involves the counter obligation to provide every reasonable safeguard for the property. The home should be a durable asset. Technically, this means that housing should be taken out of the speculative and trading class and placed on a long-time investment basis. Depreciation and obsolescence should be calculated over thirty-five years. Then the home will have a financial as well as a social value; whereas now its value is mostly social. People may then buy their homes with a reasonable assurance that they can enjoy them while they occupy them, and, should circumstances force them to sell, in so doing they will not face the loss of their little fortunes. Such is the fundamental need of housing finance, and it remains to describe how the new housing finance corporations meet the need.

It is easy to see that, in this respect, the new corporations have great advantages over older speculative schemes. Working on a large scale, they can finance each operation easily. As the money comes back in payments on one small house, it flows out again to start another dwelling. This circulation of capital is called the principle of the "revolving fund," and all the companies make much of this feature. More will be said of it later; but here let it suffice to point out that this turnover offers economy over ordinary methods, because, as Mr. John Ihlder, the housing expert, explains, the small builder's capital is usually tied up from five to eight years in each house—which is an expensive delay. Besides, the corporations can finance the resale of properties when necessary. But, important as such economies may be, perhaps the chief merit of this new scheme of financing is that it offers the home buyer greater and more secure value in those essentials of neighborhood, permanence, proper lo-

cation of house, type of house itself, and a more stabilized real estate market.

The credit of the finance corporations is of the best, backed as they are by the most responsible business interests, and organized by the local Board of Trade or Chamber of Commerce. They obtain capital on the best terms and have the best business advice. The welfare of the whole community is concerned, a factor which makes for stability, breadth of view and sound business policy.

Promotion costs—that item which appears so large on the books of most new undertakings—are low. Support of business interests and of the local press is freely given. By such means the stock is subscribed, as a rule on some plan of apportionment. Factories usually take up the majority of the shares, and often a small proportion goes to commercial and professional interests. For example, in Dallas, Texas, two hundred citizens underwrote the stock. Stock is paid for in instalments, a typical instance being the Housing Corporation of Flint, Michigan, which stipulated that 20 per cent be paid upon organization of the company, 40 per cent, on call, but not less than thirty days thereafter, and the remaining 40 per cent, not less than sixty days after the second instalment, and then not until bills for labor and material required it. It is easy to see that, on such a basis of credit, money can be obtained on the most favorable terms. The dividend rate is limited at or about 5 per cent.

The form of organization need only be mentioned. It is the familiar stock corporation, incorporated under the laws of the state, with officers and board of directors. Nearly all the corporations issue common stock only. Usually a very able executive is secured to take charge of the active management.

At this point in the description of these corporations, a great variation of methods is to be noted. The differences concern principally the scope of the enterprise. Two main classes are found: One, purely financial, finances the building and the sale of houses; while the other, in addition to financing, undertakes some, or all, of the other operations of housing, those of land subdivision (even community plan-



ning in a few cases) and the design and construction of houses. In each class there is a variety of types, which vary chiefly according to local conditions and local needs, and also according to the ambition of their organizers. It will be sufficient to point out some of the significant characteristics of each class as well as some of their defects.

Even a third type may be mentioned. This is the Janesville, Wisconsin, Corporation, which does construction mainly and places finance almost entirely in the hands of a local building and loan association.

Concerning the purely financial organizations, the best of them effectively apply principles of modern finance in housing. Compared with the other type, they have the merit of not attempting to cover too wide a field. Housing finance on a large scale is a task in itself, and building operations are quite another kind of enterprise. To combine the two in a large scale organization is not easy. We hear much of the economies of operation on a large scale, but not so much of the losses incurred on a large scale through wrong policy, mistakes, inexperience or inefficient personnel. Such weaknesses may develop in a newly organized corporation, and it may be said that large scale operation is better arrived at through a process of growth rather than through creation. In some cases, this difficulty of combining too many functions in an unwieldy enterprise is avoided by having separate corporations—one for financing, and one for design and construction.

The danger of the purely financial corporation is that it may not be able to control the housing product on which it loans money. Unless it is firm in withholding loans from properties that do not meet the highest standards in design and construction and in permanent neighborhood values, this type of corporation cannot insure to home buyers the soundest possible security. In a community where housing standards are low and obsolete, builders and real estate interests will be apt to resist efforts at improvement. In this case the management will have need of much initiative, backbone and tact if it is to secure low cost and soundly financed houses. Among the executives of a finance corpora-

tion should be experts in construction and design of houses and in community planning—men who understand the history of the steady progress in small house design and who are able to imagine what value present housing standards will have twenty years from now. The usual form of real estate appraisal considers existing values chiefly and takes too little account of depreciation and obsolescence.

Regarding variations of this type of company—the purely financial type—it may perform all of the operations of finance or else it may supplement existing institutions where these are functioning effectively. In this way it may effect much economy in reducing the cost of what are known as "service charges." Under the head of service charges come a multitude of premiums for loan or mortgages, fees to surveyors or to lawyers for titles, deeds, contracts, title guarantees, etc., a long list of small items which add up to a surprising total. This economy was one of the reasons for the growth of the building and loan system, and is said to total about 10 per cent. of the cost of a house in many cases. The Pennsylvania State Chamber of Commerce report mentions service charges as from 1 to 6 per cent. on sums advanced to buyers. The workings of the Cleveland Homes Co. throw added light on this factor. "A real estate dealer of average means finds, after a comparatively few transactions, that most of his capital is tied up for a long period so that he is compelled to mark up the price asked for each house in order to cover his carrying charges and financing cost." This bears out Mr. Ihlder's statement above. The Cleveland Homes Company "discounts" mortgages. It also buys homes for an owner, obtaining a 10 per cent. discount. In these transactions, after charging the normal 3 per cent. for making the sale and the customary commission for placing fire insurance; it saves for the buyer about \$400 on a \$3,000 deal. The commission is retained by the company to pay operating expenses and capital charges, including a 6 per cent. dividend, and any surplus is distributed to purchasers as a deferred dividend. The Cleveland Homes Company uses mortgages to obtain collateral

trust notes bearing interest, which are sold through the usual channels, thus making its capital liquid.

This last is one illustration of the operation of the "revolving fund," mentioned above. In a sense, what nearly all these companies do is to finance that part of the undertaking which is usually covered by second mortgages. Indeed, for this reason, these finance companies are sometimes known as "second mortgage corporations." Particularly under the present abnormal building costs, loaning interests and investors fear to take up second mortgages on new construction. Under the mortgage system, the second mortgage represents the peak value of real estate, which, in a building built today, may be wiped out in a few years as costs descend. This risk the finance corporations assume. Of the rest of the capital about 60 per cent. comes from outside sources in the form of first mortgage loans or notes, from savings banks, loaning institutions, investors or by transactions with building and loan associations; and 10 per cent. is the first payment made by the home buyer. Here a further saving is possible, chiefly for two reasons. The company, by forcing high standards of security on its housing, can borrow more favorably; and it can get loans in bulk, either on its credit, or as mortgages placed on a group of houses, thus saving overhead costs. As Mr. Lee J. Frankel, vice-president of the Metropolitan Life Insurance Co., of N. Y. City, well says: "The cost of placing many small loans cuts into the interest rate." Some companies, in addition to these loaning and selling functions, finance builders, and here, by judicious purchasing of building materials, they may greatly cheapen construction costs.

Such is the character of the companies which confine themselves to finance. But they do not promise such efficiency as those—particularly when organized separately—which do both financing and manufacturing of housing. There are a large number of this latter type all over the country, and a most successful group is operating in Michigan, notably in the towns of Flint and Pontiac.

This part of Michigan is the region of the motor industries, like the huge Gen-

eral Motors Corporation, the expansion of which, after the war, added to the entrance of other automobile industries into the district, precipitating a particularly acute housing shortage. The companies organized in this region had the benefit of the example and experience of several extensive housing developments, previously created—the splendid industrial housing community of the General Motors, and the villages of the U. S. Government war housing.

Under successful management, housing of this type is apt to be the best. There are not only the economies of large scale construction to be had, but also the important saving in community planning, land subdivision and site engineering in the shape of streets, paths, sewers, water, gas, etc. A peculiar local advantage of this type occurs in La Crosse, Wisconsin, where difficult land contours require much grading, which is cheapest done on a large scale. This is an interesting illustration of how local conditions affect the character of the enterprise. There is apt to be an advantage in having the company furnish a lot, for, as the Massachusetts Homestead Commission states in an annual report, "It is estimated that 70 per cent. of workmen who buy building lots never buy a home." The cause assigned for this startling fact is that the lots sold are either too high, or unsuitable, or in a poor neighborhood. The workman naturally is not able to judge these factors when he buys his land. The companies usually make a careful survey of the community, quietly place options on favorable tracts of land without letting their purpose be known. They prefer to build in groups in different parts of the community. Those familiar with housing operations know that, in construction alone, a saving of 15 per cent. to 30 per cent. or more is possible on such a large scale; and when we add this economy to the saving in the financing, we begin to see what the introduction of manufacturing—or production—ideas into housing may mean.

Thus, in general terms, runs the account of the two types of corporations—those which are purely financial, and those which cover more of the many fields of



housing. Each has its value in certain conditions; but in any case, no matter what the form of the enterprise, it will fall short of its object unless it makes sure that the product it finances is not only as cheap as possible, but is a sound investment.

It remains to consider the technical details of the transaction between the finance corporation and the individual buyer—the person who, after all is said, is the central figure in housing finance.

These technical details are those of the sale plans. Almost all the corporations follow the method of taking payments in instalments, which has long been the custom in financing small houses. This is done in a variety of ways; but here again classification is difficult or else misleading. For I am forced to conclude that one type which is found in a number of cases is so superior to the rest that it is reasonable to consider it the best type; while the rest are either defective or are prevented by unusual local conditions from attaining it. In a word, that type is the best which deals with the buyer in the simplest, most direct, and most responsible way. This principle above all others should be found in a sale plan. To tie the buyer up in a system of payments on first and second mortgages, or on notes, or several little debts owed both to the finance corporation and to other agents, sales-talk of technical refinements like amortization, discounts, etc.; transferring mortgages to a bank or investor, or to a third party, to whom, if the home buyer is forced to suspend payments temporarily through a disaster like death or disability, the finance corporation must refer him—all this may be clear enough to an accountant, but I confess that it often puzzles me and makes me sympathize with the poor home buyer, who, untrained in finance, faces the tangle for the first time. Such complication and such expertizing of what can be made a simple transaction seems to show a want of imagination in realizing the human factor. Accordingly, I prefer those plans which sum up all these technical intricacies in one phrase like "10 per cent. down, 10 per cent. a year until paid for," or "10 per cent. down, 1 per cent. a

month thereafter." These are the methods of the Kenosha, Wisconsin, and of the Janesville, Wisconsin, companies and of some others. In this plan the purchaser deals only with the company specializing in one kind of business, and comes to put his confidence in it. He is not confused by being referred to a third party for a mortgage or loan. In its turn the company is thereby made more responsible toward him. The plan of payments is simple, and the buyer—and particularly his women folk, who are not to be ignored—knows at any moment the exact status of the transaction.

But the chief merit of this simple plan is that it best meets that indispensable requirement of re-sale if the homeowner is compelled by circumstances to move. The buyer can then be easily assisted to take back whatever equity is reasonably his in the transaction without friction or misunderstanding; whereas he might feel upset and suspicious of being cheated if compelled to untangle his equity and his obligations from a series of notes and mortgages that were held by different parties.

One point deserves mention here. Some companies find it desirable to retain an option on the property in case of resale. This prevents the property from passing into undesirable hands, especially of those loan and real estate sharks who prey on small investors.

Thus also, from the viewpoint of both company and buyer, it would seem an economy to sum up all the transactions with the individual home buyer thus in one simple scheme of payments made to the finance corporation solely; and to leave to the company the business of borrowing, from outside sources, in lump sums at a low interest rate all loan or mortgage money. The only exception to this rule would seem to be those cases where the company co-operates with the local building and loan associations. The loan associations have a complex scheme of payments, but it is one well established in local customs and everyone comes to understand it.

The above describes the general feature of the simple instalment scheme, but there are other details which should be

understood. From the viewpoint of the welfare of the buyer authorities agree that it is best for him to pay up his debt as rapidly as he can without shouldering too great a payment. This is a most important point. Many payment schemes include in their "10 per cent. down, 1 per cent. a month" formula only the purchase cost of the house. Thus they overlook important items of depreciation, obsolescence, taxes, life and fire insurance, coal, electricity, that mount up to a figure, which, I have calculated, may in some cases be one-third of a normal rental (4 per cent., with a rental established to return 12 per cent. gross on the investment). This may make the burden on the buyer too high. The burden, housing experts agree, should not exceed 25 per cent. of a family income, or, as stated, "one week's wages in each month spent for shelter." Some authorities declare that 20 per cent. is a maximum. But if we assume 25 per cent. as reasonable, this means that, under a "1 per cent. a month" scheme, a house costing \$3,500 should not be bought by a family with less than \$35 a week steady income or a little less than \$2,000 a year. Then in the amount in the family budget available for shelter, \$420 a year, only about \$300 or less is really available for payments to the corporation. Disregarding interest due the company on the loan and taking \$300 as the annual payment to the company—which is what deferred payment amounts to—and disregarding, also, amortization, on flat payments the debt would be extinguished in about ten years and six months. It should be remarked that the City and Suburban Homes Co., of New York City, follows like methods.

Stated in more detail and more accurately, I submit the following taken from the Janesville, Wisconsin, Corporation, which seems to me one of the best:

**Transaction with Purchaser.**

Cost of house.....	\$3,900.00
Added 10% safety margin.....	300.00
Cost of lot, improved.....	600.00
<hr/>	
Total cost.....	\$3,900.00
Deposit on purchase, 10%.....	\$390.00
First mortgage, 60%.....	2,340.00
Second mortgage, 30%.....	1,170.00
<hr/>	
Total sale transaction.....	\$3,900.00

Interest on 1st mortgage at 6%..	\$140.40
Interest on 2d mortgage at 7%..	81.90
Taxes, water rates, insurance....	70.00
Depreciation and repairs.....	39.00
<hr/>	
Total yearly cost.....	\$331.00
Monthly cost.....	\$27.60
Monthly charge.....	39.00
Difference to be applied on 2d mortgage .....	11.40

At the end of first year, providing no additional payments have been made on the second mortgage, the situation will be as follows:

First mortgage.....	\$2,340.00
Second mortgage.....	1,032.00

This plan assumes a weekly wage of \$39.00. It is clear that such a plan has the merit of being simple and easily grasped. It will be noted that the items "monthly cost" and "difference to be applied on 2nd mortgage" are misleading, for they vary with each payment. However, I would suggest another form which might be still simpler. Following out the principles outlined above, namely, of centering all the homeowner's dealings with the finance corporations and eliminating other parties in the transaction, I would dispense with the mortgage form. Then the buyers deal directly with the finance corporation, which is in a better position than the homebuyer to negotiate collectively the individual mortgage loans, or else to obtain in other ways adequate financing by dealing direct with the loaning interests, thus making the business a better "banking proposition." The finance corporation would then transact the dealings with the individual homebuyer by a sale contract, under the terms of which the finance corporation would retain title to the property until the last payment for it was made, after which the title would pass to the homeowner. Obsolescence should be introduced at a figure of 1½ per cent. on a twenty-year basis, meaning that a house will, at the end of that period, very likely be worth 30 per cent. less than it is now because its design has become antiquated. The specific form of sale plan would then be calculated for a family income of \$39 per week:



**Transaction with Purchaser.**

Cost of house.....	\$3,000.00
Added 10% safety margin.....	300.00
Cost of lot, improved.....	600.00
<hr/>	
Total cost.....	\$3,900.00
Deposit on purchase, 10%.....	\$390.00
Debt to be paid off.....	3,510.00
<hr/>	
Total sale transaction.....	\$3,900.00
Interest at 6% and repayment of principal .....	\$300.50
Taxes, water rates, life and fire insurance .....	70.00
Depreciation and repairs at 1%..	39.00
Obsolescence at 1½%.....	58.50
<hr/>	
Total yearly cost.....	\$468.00
Monthly charge.....	39.00

Under this scheme the debt will be paid up in about 20 years. This is too long a period, a dozen years being better. There are three ways of reducing the time factor, viz.—increasing initial payment demanded of homebuyer, and lowering the cost of the house either by cheapening cost of construction and finance or by reducing its size. The 10 per cent. "safety margin" is a service charge of the finance corporation for the financing operation which, after paying expenses, may be returned to the buyer as a dividend. In this figuring the reader may have noted that the cost of house and the wage necessary to pay for it are high. Nevertheless the cost is only 10 per cent. a year, which is a normal rental figure. The reader will perceive that this suggested form of financing and sale plan is a simplification of the methods of some of the companies like the Cleveland Homes Co.

Certain further points of interest in this sale plan deserve notice. As to the initial payment, though this is usually 10 per cent., it is sometimes 20 per cent. as in the case of the La Porte, Indiana, Housing Corporation, while some companies do not require it at all. This latter practice is not considered ideal, because an initial payment, besides helping the company, is an index of a man's thrift, his good faith, and it provides him with a small reserve. There is no reason, however, why a buyer, if willing, should not make a larger payment, nor why he should not anticipate his regular payments. Incidentally, he should also be permitted to postpone his payments or re-

duce them temporarily if he meets with financial troubles, due to disability, sickness or death in family, rapid succession of births, etc. It will be seen that during the first three or four years, the payments go principally for paying interest to the company on the loan and not much is left for amortization. After that amortization sets in with accelerating rapidity as the principal of the loan is paid off. Hence the advantage of larger initial payments and heavier instalment payments during the first two years, when they can be made without hardship. It will be seen that all this mathematical relationship of home buyer's family budget to the sale price of his home—his wage scale, his sinking fund to cover charges on his property, his payments to the company, the charges for interest, discounts and amortization, cost of financing and cost and type of housing—all forms an intricate cycle of relationships and variables which requires nice judgment and accurate calculation to make it workable in practice. It shows how, since the war, abnormal building costs have created an excessive value for that specific variable which has made the equation almost insolvable. It demonstrates further—if such demonstration be needed—how absolutely necessary are sound principles of finance, together with rigid cutting of costs in every department of housing through large scale operation.

Two further points are to be noted. One is the practice adopted by some corporations of handling a second mortgage or its equivalent only, and then, when that is paid off, leaving the home buyer with a note or first mortgage on his hands. I believe it is well understood that standards of thrift advise us that, while it is good finance for a business to operate on borrowed capital, it is not the best practice for an individual. The old-fashioned precept of keep out of debt still holds true as ever. The other factor is insurance. Wherever possible the expense of both life and fire insurance should be included in the sinking fund payments, particularly in such a way that the death or disability of the owner does not involve the family in the loss of the roof over their heads. This practice is the rule in a few companies.

All these considerations serve to bring out the need of centering all legitimate costs in the simplest possible sale scheme, not rigid either, but with enough flexibility in it to meet conditions as they arise. The company should be direct and frank with the buyer. The home buyer should be patiently instructed not to overlook the important costs of depreciation, obsolescence, taxes, insurance, water rates, etc., and other items which enter into the cost of his home besides those covered in his payments to the financial corporation. Otherwise, in ignoring these he may assume an obligation which is too great for his income. He should be encouraged to adjust his burden of payments to the other items in the family budget.

In this way he can buy a home and pay for it in about nine to a dozen years, depending on costs of housing in the locality and on the standards of living as reflected in design of the house. Then—here are the two most vital factors of all—if efficient large scale operation be attained, the annual payments will be no higher (they may even be lower) than rentals of housing built under small scale,

inefficient methods; and, further, if the proper financial safeguards are thrown around the properties, the owners may feel that their homes have a financial as well as a social value. Either they can dispose of them at need with little or no loss, or, if they hold them, they own them after, so to speak, paying rent for some ten or twelve years. In a permanent, properly protected neighborhood the house will always have a good value both socially and financially, each factor enhancing the other.

By such methods this splendid system of Board of Trade sponsored finance corporations is designed to enable homeownership once more to compete with renting in the United States. One should not suppose that renting has any advantage over homeownership but a financial one. That advantage will in large measure disappear if sound methods are applied to housing finance. Then, with homeownership equal once more to renting on the financial side, we may trust to the superior social value of homeownership in all but exceptional cases to influence our people to become once again a nation of home owners.



# THE WORKS OF AN ENGLISH CRITIC

By CHARLES OVER CORNELIUS

THE contributions of the English critic, Lawrence Weaver, to current architectural bibliography imply that the subject of architecture interests him first of all as an expression of a primitive instinct, whose development, to use his own words, takes its place in the larger history of social growth. This interest, which in its breadth must contain many detailed subdivisions, is, in general, twofold, and in its sane balance and keen insight holds much to refresh and inspire. Trained as an architect, with opportunities for intimate acquaintance with the best examples of the past, particularly in his own country, Mr. Weaver confesses a respect for traditions in architecture and a knowledge of English traditions which afford the surest bases for present criticism and judgment. At the same time his constructive impulse is directed toward the continued improvement of domestic architecture through an adjustment between modern social conditions and established methods in building, both of which tend to leave their mark upon the houses of today.

The concentration of attention primarily upon domestic architecture and the related arts, together with the limitation of this attention to English work of the past and present, renders his study of particular usefulness to housebuilders today when the influence of English domestic art in American architecture and household decoration is paramount and finds a natural setting in the midst of the Anglo-Saxon traditions of this country.

In his archæological studies Mr. Weaver has given to the public certain facts with regard to sixteenth and seventeenth century building, whose importance is not wholly archæological nor abstract. To him we owe the republication of "The First and Chief Grounds of Architecture," by John Shute,\* which was the first book on architecture published in England.

In his paper on the building accounts

of the fifty-one city churches designed by Sir Christopher Wren† there is much material of interest to students of Georgian architecture. The accounts present a running commentary upon the great architect's business and building methods, which constitute the basis of much of our present system of contracts and accounting in building work. The details of materials, quantities and cost, of plumbers' and decorators' work, and the employment of engineers and surveyors present a picture of the labor conditions in London just after the great fire.

This archæological work, avowedly a recreation, is but a small part of Mr. Weaver's activity. His interest in the art of the past is that of the student of evolution who desires primarily to interpret the present. In his discussions and critical appreciation of modern country houses‡ he emphasizes the importance of retaining the traditions of building which have gone before. In the smaller English cottages,§ built for occupancy by persons of moderate means, he finds a surprising persistence of tradition and an expression in building of the impulse which animates the folk art of nations. The problem of cottage building resolves itself into the question of what to omit without falling below the standard of efficiency. At the same time the beauty which these inexpensive buildings possess results from the skill of their designers rather than the money spent upon their construction.

The repair and enlargement of small country houses, one chapter of "Small Country Houses of Today," have been treated more at length in a second volume,¶ in which are described and criticized nearly forty cottages dating from

†*The Complete Building Accounts of the City Churches (Parochial)*, Designed by Sir Christopher Wren. *Archæologia*, Volume 66, pp. 1 to 60.

‡*Small Country Houses of Today*, edited by Lawrence Weaver, London, 1910, Country Life Press. *The House and Its Equipment*, by Lawrence Weaver.

§*Country Life Book of Cottages*, by Lawrence Weaver, 1913.

¶*Small Country Houses, Their Repair and Enlargement*, by Lawrence Weaver, 1915.

\**The First and Chief Grounds of Architecture*, by John Shute, 1563. Fac-simile Edition limited to 1,000 copies.

the fifteenth through the nineteenth century, all of which have been enlarged and made suitable for twentieth century usage. In this discussion are emphasized the desirability of retaining all work executed before good tradition broke down in Victorianism, the employment of native material and the importance of doing the minimum rather than the maximum amount of repair.

The splendid monograph on Mr. Lutyens' work\* is one of the best known of the recent works on living architects. Rich in illustration, both photographic views and line drawings, this impressive volume has had a marked influence upon American country house architecture by reason of its popularity both in architectural offices and private libraries. It emphasizes Mr. Weaver's thesis that architecture "needs to be brought back into the current of normal, intelligent thought," since the "driving power for good building must come from an enlightened public opinion."

The subject of garden art comes largely into the Lutyens' monograph and is echoed in the volume done in conjunction with Miss Jekyll.† The volume on English lead work‡ also devotes much space to garden sculpture and architectural embellishment. This volume gives opportunity for the expression of a personal interest and stands next to the monograph upon Mr. Lutyens' work in importance as a unique contribution to architectural

\**Houses and Gardens* by E. L. Lutyens, by Lawrence Weaver, London.

†*Gardens for Small Country Houses*, by Gertrude Jekyll and Lawrence Weaver.

‡*English Lead Work. Its Art and History* by Lawrence Weaver, London, 1909. *Some English Architectural Lead Work*, by Lawrence Weaver, 7, 8, 9, 10 and 12.

literature. For practical architectural accessories, as well as decorative garden ornaments, his plea for the fitness of lead should help to revive its employment after its nineteenth century fall from popularity.

In 1915, when the world war was well under way, the timely volume on memorial art was published.§ The development of English memorial art is traced in a short introductory text, and the remainder of the book is given over to a consideration of the many personal memorials which form so striking and interesting a feature in English country churches and great cathedrals.

While the subjects covered by a list of Mr. Weaver's books seem diversified, it is evident that a pervading and intense love and knowledge of architecture embraces them all. Where the special subjects of complementary work are taken up, the essential relation between the mistress and the handmaid is never lost. The many charming and beautiful decorative details scattered throughout England deserve to be recorded and described quite aside from the inspiration which such publication holds for those on this side of the sea who cannot visit them. The work of the leaders of modern English building will fail to have its full influence upon contemporary architecture unless it is spread before all who are interested in learning of it. And this double work it is which Mr. Weaver has undertaken, thoroughly equipped for the task and filled with an enthusiasm for all that is beautiful in English building, which is both convincing and contagious.

§*Memorials and Monuments*, by Lawrence Weaver, Scribner's, 1915.



*The*  
**AMERICAN CHICLE COMPANY'S FACTORY  
LONG ISLAND CITY, N. Y**



*Ballinger & Perrot, Architects*

**I**S architectural design of any practical value in factory buildings? The traditional answer of the majority of manufacturers may be read in the wonderful ugliness of industrial districts. On this question, however, as on many another, recent experience has brought about a reversal of opinion. During and since the war manufacturers have been obliged to give serious study to the causes of labor turnover, and it has been discovered that the building is a separate and distinct problem of design in an industrial plant.

The function of the building is not merely to house machinery and industrial processes, but also to enable the operating force to carry on its work with the least possible physical discomfort and mental hazard. The architect is a specialist in building design, and in the majority of the newer industrial plants the practical value of his specialty has been recognized.

This assertion is made on the strength of figures supplied by the Statistical Department of the F. W. Dodge Company for the great manufacturing area north of the Ohio and west of the Missouri, which show that of 5,447 industrial plants begun in the first ten months of the current year, 2,786 were designed in collaboration with architects. Incidentally these figures give some idea of the tremendous industrial expansion which has been taking place. The 5,447 plants contain a floor space of 119,353,500 square feet.

Most of the newer factories are of reinforced concrete. Partly for this reason, and partly because the architect's collaboration on industrial plants in considerable numbers is so recent a development, factory design, from the point of view of art, is as tentative as office build-

ing design was, say, twenty years ago. However, it will undoubtedly make rapid progress, helped by the notable advance in artistic treatment of concrete surfaces achieved in the last few years.

The American Chicle Company's Building, in Long Island City, may perhaps be instanced as typical of the stage of progress reached in factory design in concrete. It is effective in mass and line, and an air of dignity has been imparted to a structure of impressive size. On the other hand, the decorative details, particularly the color insets, are inferior in merit; and in any event do not exemplify the special decorative possibilities inherent in concrete.

The building covers a city square, and is 200 feet wide by 600 feet long, with an interior court 40 feet by 380. The front elevation is five stories high, the remaining elevations being four stories high. The fifth story is provided solely for the accommodation of the employees. It contains separate dining rooms for men and women, a kitchen and rest rooms. On the main roof, at each side of the building, is a wire enclosure for recreation. There is also a dispensary, with waiting rooms, an operating room, nurses' quarters and rest rooms.

The structure, together with the equipment, was designed by Ballinger & Perrot, architects and engineers. The exterior walls, including the spandrels, are of reinforced concrete. Flat slab construction was employed in the floors. Bays were arranged with a view to economy of construction, in units 20 feet by 20. About thirteen acres of floor space is available. No expansion joints were employed in the structure.

The courtyard, which floods the interior of the building with light, carries

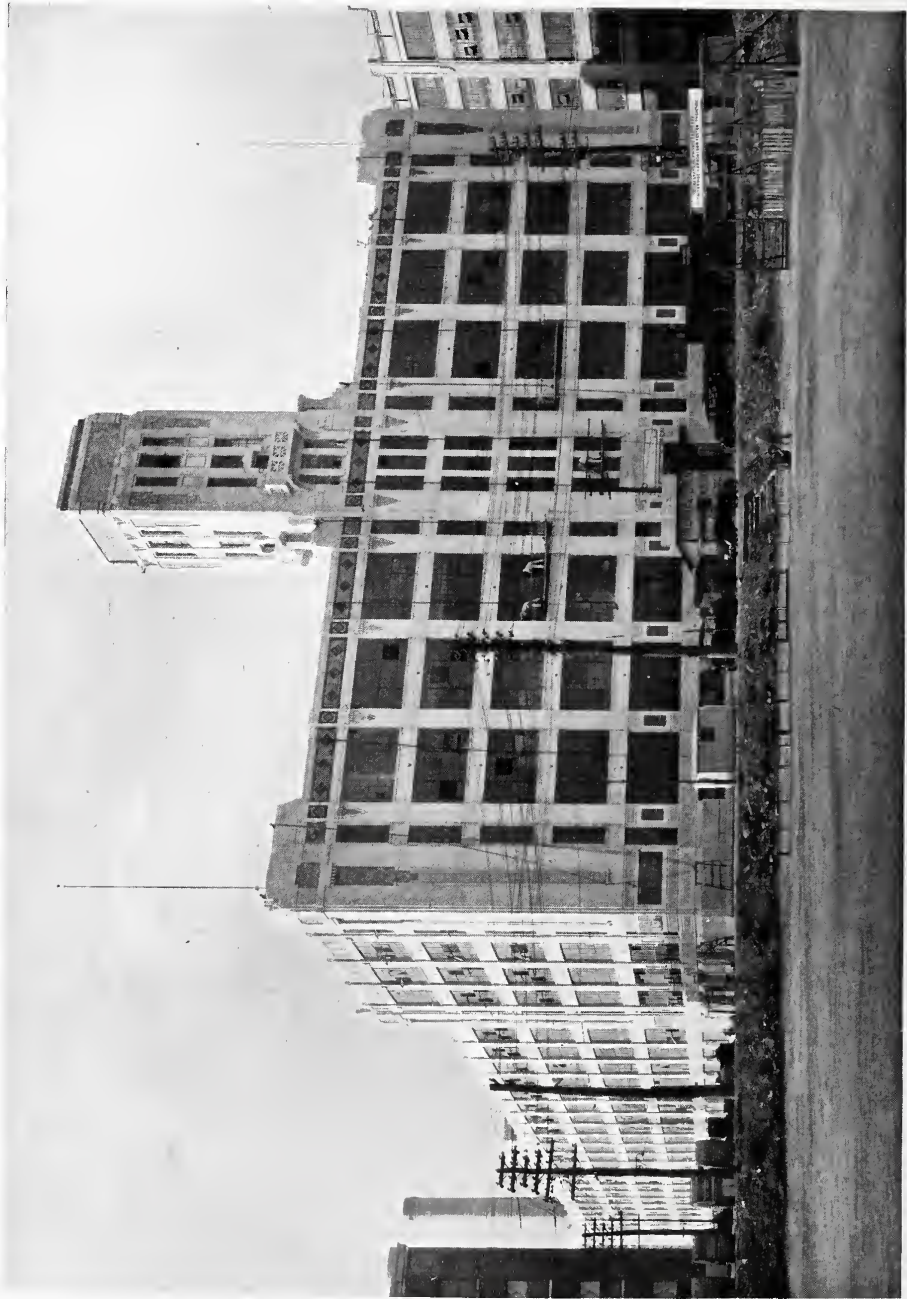

AMERICAN CHICLE COMPANY'S FACTORY, LONG ISLAND CITY, N. Y. BALLINGER & PERROT (NOW THE BALLINGER COMPANY), ARCHITECTS AND ENGINEERS.





AMERICAN CHILE COMPANY'S FACTORY, LONG ISLAND CITY, N. Y. BALLINGER & PERROT (NOW THE BALLINGER COMPANY), ARCHITECTS AND ENGINEERS.



AMERICAN CHICLE COMPANY'S FACTORY, LONG ISLAND CITY, N. Y.  
Ballinger & Perrot (now The Ballinger Company), Architects and Engineers.

two tracks entering through the rear of the first story. All freight is loaded and unloaded in the courtyard, relieving the neighborhood of the unsightly litter of freight platforms. About sixteen cars can be handled at one time. Incoming raw materials are taken to the top story by elevators or automatic conveyers. The raw chicle is stored on the roof, where it can be sprayed at regular intervals to keep it moist. The routing of the processes and the movement of the materials enable automatic gravity conveyors to perform a large share of the work usually done by hand or by elevators.

The air inside the plant is purified by washing and is held at constant temperature and humidity throughout the year.

The coal bunker above the boiler room has gates spaced at regular intervals along the bottom of the bunker. Underneath the bunker a coal weigh-larry travels the length of the boiler room, feeding all the boilers. The weigh-larry

is equipped with automatic scales, which weigh the coal furnished to each boiler and deliver a ticket to the operator, so that record can be kept of the cost of the coal consumed by each boiler.

The tower shelters the huge tanks needed by the plant. An automatic sprinkler system is supplied from a 50,000 gallon gravity tank enclosed in the tower. There is a fire pump having a capacity of 1,000 gallons a minute in the power house, taking connection from the street water main. The fire protection scheme is completed by a system of standpipes and fire hose in stair towers at the corners of the building.

It is a measure of the skill of the designers that the water tower, the fire-stair towers, the smokestack and the freight platforms have been so disposed and treated as to improve the appearance of the building, the water tower becoming the central and most interesting feature of the design.



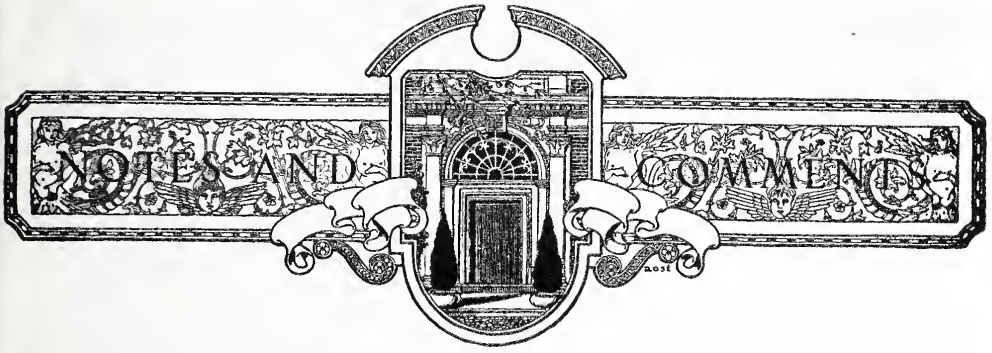

**A Motion Picture Theatre in a Unique Setting**

The environment of the Winema Theatre is probably as nearly unique as any setting that is likely to appear upon its own motion picture screen. It is in a lumber town in a primeval

mountain forest of redwoods, in Humboldt County, Cal. The town of Scotia, with its lumber mills, stores, dwellings, schools, churches and other buildings, is owned by the Pacific Lumber Company, and the theatre has been built by the company for its employes, the name "Winema" being derived from a local Indian legend.

The theatre, dedicated in November, was arranged for by the late Chauncey W. Penoyer, president of the company. It is operated by a joint committee from three organizations of employes—the Scotia Hospital Association, the Scotia Club and the Scotia Volunteer Fire Department. After paying the company a small interest on the investment and depreciation charges, the committee divides the net profits among the three associations. The theatre was designed by Alfred Henry Jacobs, architect, of San Francisco.

It is built entirely of redwood, even the foundations being of this material. The structure is 130 feet long by 58 feet wide, and seats 600. It is entered through a vestibule which leads to a foyer giving access to the auditorium. Off the foyer are retiring rooms for men and women. The auditorium averages 40 feet in height. The proscenium arch opening is 22 by 32 feet. The auditorium is lighted by fixtures constructed of wood and cloth and suspended from the roof trusses. Wooden brackets illuminate the side walls.

A note of interest is added to the interior by the coupling of the main roof trusses.

These, designed on the hammer beam pattern, are similar to those used in early English Gothic churches. The trusses rest on coupled columns, or rather posts, each 10 by 10 inches and approximately 25 feet long. Redwood studding is used in the construction of the interior walls between trusses, and the studs are bridged in a decorative manner. Sheathing forms the upper wall surfaces.

A wainscot below, of board and batten, serves to conceal the indirect radiation and at the same time gives a practicable wall against which to place seats.

The projection room is raised above the floor of the auditorium so that the center of the projecting cone is normal to the center of the picture screen. The "throw" is 90 feet.

The floor of the auditorium is a true bowl. There are two side aisles, a center bank of seats, and the eight exits make it possible to empty the house in a very short time.

The building is heated by a system of direct-indirect radiation. The air enters from the outside near the ground and passes over concealed radiators behind the wainscot, discharging by gravity into the auditorium, and thence rising and escaping by means of ventilators placed in dormers on the roof.

The entrance vestibule is supported by eight redwood trunks approximately two feet in diameter and with the bark intact. The long 10 by 10-inch posts supporting the roof trusses are recalled on the exterior, where the wall treatment is a combination of board and batten, with lap siding, all rough from the saw. Artificial color is wholly absent, both in the interior and on the exterior—the redwood having been given an oiled natural finish.

A. L. BLACK.



WINEMA THEATRE, SCOTIA, HUMBOLDT COUNTY, CAL.  
Alfred Henry Jacobs, Architect



SIDE VIEW—WINEMA THEATRE, SCOTIA, HUMBOLDT COUNTY, CAL.  
Alfred Henry Jacobs, Architect.





AUDITORIUM—WINEMA THEATRE, SCOTIA, HUMBOLDT COUNTY, CAL.  
Alfred Henry Jacobs, Architect.



FOYER—WINEMA THEATRE, SCOTIA, HUMBOLDT COUNTY, CAL.  
Alfred Henry Jacobs, Architect.



DETAIL OF AUDITORIUM—WINEMA THEATRE, SCOTIA, HUMBOLDT COUNTY, CAL. ALFRED HENRY JACOBS, ARCHITECT.









GETTY CENTER LIBRARY



3 3125 00669 9819



