



**Calhoun: The NPS Institutional Archive**  
**DSpace Repository**

---

Theses and Dissertations

1. Thesis and Dissertation Collection, all items

---

2008-09

Model-based methodology for system of systems architecture development with application to the recapitalization of the future towing and salvage platform

Addington, Christopher D.

Monterey, California

---

<http://hdl.handle.net/10945/3886>

*Downloaded from NPS Archive: Calhoun*



Calhoun is a project of the Dudley Knox Library at NPS, furthering the precepts and goals of open government and government transparency. All information contained herein has been approved for release by the NPS Public Affairs Officer.

**Dudley Knox Library / Naval Postgraduate School**  
**411 Dyer Road / 1 University Circle**  
**Monterey, California USA 93943**

<http://www.nps.edu/library>



**NAVAL  
POSTGRADUATE  
SCHOOL**

**MONTEREY, CALIFORNIA**

**THESIS**

**MODEL-BASED METHODOLOGY FOR SYSTEM OF  
SYSTEMS ARCHITECTURE DEVELOPMENT WITH  
APPLICATION TO THE RECAPITALIZATION OF THE  
FUTURE TOWING AND SALVAGE PLATFORM**

by

Christopher D. Addington

September 2008

Thesis Advisor:  
Second Reader:

Clifford Whitcomb  
Fotis Papoulias

**Approved for public release; distribution is unlimited**

THIS PAGE INTENTIONALLY LEFT BLANK

REPORT DOCUMENTATION PAGE			Form Approved OMB No. 0704-0188	
Public reporting burden for this collection of information is estimated to average 1 hour per response, including the time for reviewing instruction, searching existing data sources, gathering and maintaining the data needed, and completing and reviewing the collection of information. Send comments regarding this burden estimate or any other aspect of this collection of information, including suggestions for reducing this burden, to Washington headquarters Services, Directorate for Information Operations and Reports, 1215 Jefferson Davis Highway, Suite 1204, Arlington, VA 22202-4302, and to the Office of Management and Budget, Paperwork Reduction Project (0704-0188) Washington DC 20503.				
1. AGENCY USE ONLY (Leave blank)		2. REPORT DATE September 2008	3. REPORT TYPE AND DATES COVERED Master's Thesis	
4. TITLE AND SUBTITLE MODEL-Based Methodology for System of Systems Architecture Development with Application to the Recapitalization of the Future Towing and Salvage Platform			5. FUNDING NUMBERS	
6. AUTHOR(S) Christopher D. Addington				
7. PERFORMING ORGANIZATION NAME(S) AND ADDRESS(ES) Naval Postgraduate School Monterey, CA 93943-5000			8. PERFORMING ORGANIZATION REPORT NUMBER	
9. SPONSORING /MONITORING AGENCY NAME(S) AND ADDRESS(ES) N/A			10. SPONSORING/MONITORING AGENCY REPORT NUMBER	
11. SUPPLEMENTARY NOTES The views expressed in this thesis are those of the author and do not reflect the official policy or position of the Department of Defense or the U.S. Government.				
12a. DISTRIBUTION / AVAILABILITY STATEMENT Approved for public release; distribution is unlimited			12b. DISTRIBUTION CODE A	
13. ABSTRACT (maximum 200 words) The United States Navy owns four salvage ships and four towing ships that will reach the end of their 40-year life expectancy in 2019. The program manager for these vessels has a set of desirable performance requirements for a new ship class, T-ARS(X), which combines the capabilities from both the salvage and towing ship classes. The need to develop a recapitalization strategy based on either designing a new ship class based on these desirable requirements or purchasing commercial capabilities based on the salvage and towing community's needs is paramount. Meanwhile, the Department of Defense (DoD) has shifted defense planning from the specific service requirements generating system (RGS) acquisition to the Joint Capabilities Integration and Development System (JCIDS) approach that focuses on requirements generation based on customer need. This thesis explores how to use systems architecting principles in the context of model-based systems engineering (MBSE) to incorporate the capabilities needed for towing and salvage recapitalization into a cohesive framework for developing the T-ARS(X) requirement specification. The CORE design tool is used to implement the MBSE architecting process using the Naval Architecture Elements Reference Guide (NAERG) and standardized operational tasks to create DODAF v1.5 products from system models. The requirements generated from the architecture model are compared with the current, combined towing and salvage-capable commercial platforms for analysis. Based on the methodology presented, the towing and salvage community now has the basis to perform a capabilities-based analysis of alternatives (AoA) for the T-ARS(X) recapitalization.				
14. SUBJECT TERMS Architecture, CORE, DODAF, DOD 5000.2, Enterprise Architecture, JCIDS, MSFSC, Salvage, Systems Architecting, Systems Engineering, SUPSALV, T-ATF, T-ARS, Towing			15. NUMBER OF PAGES 178	
			16. PRICE CODE	
17. SECURITY CLASSIFICATION OF REPORT Unclassified	18. SECURITY CLASSIFICATION OF THIS PAGE Unclassified	19. SECURITY CLASSIFICATION OF ABSTRACT Unclassified	20. LIMITATION OF ABSTRACT UU	

THIS PAGE INTENTIONALLY LEFT BLANK

**Approved for public release; distribution is unlimited**

**MODEL-BASED METHODOLOGY FOR SYSTEM OF SYSTEMS  
ARCHITECTURE DEVELOPMENT WITH APPLICATION TO THE  
RECAPITALIZATION OF THE FUTURE TOWING AND SALVAGE  
PLATFORM**

Christopher D. Addington  
Lieutenant, United States Navy  
B.S., University of Florida, 2000

Submitted in partial fulfillment of the  
requirements for the degree of

**MASTER OF SCIENCE IN SYSTEMS ENGINEERING**

from the

**NAVAL POSTGRADUATE SCHOOL  
September 2008**

Author: Christopher D. Addington

Approved by: Clifford Whitcomb  
Thesis Advisor

Fotis Papoulias  
Second Reader

David Olwell  
Chairman, Department of Systems Engineering

THIS PAGE INTENTIONALLY LEFT BLANK

## **ABSTRACT**

The United States Navy owns four salvage ships and four towing ships that will reach the end of their 40-year life expectancy in 2019. The program manager for these vessels has a set of desirable performance requirements for a new ship class, T-ARS(X), which combines the capabilities from both the salvage and towing ship classes. The need to develop a recapitalization strategy based on either designing a new ship class based on these desirable requirements or purchasing commercial capabilities based on the salvage and towing community's needs is paramount. Meanwhile, the Department of Defense (DoD) has shifted defense planning from the specific service requirements generating system (RGS) acquisition to the Joint Capabilities Integration and Development System (JCIDS) approach that focuses on requirements generation based on customer need. This thesis explores how to use systems architecting principles in the context of model-based systems engineering (MBSE) to incorporate the capabilities needed for towing and salvage recapitalization into a cohesive framework for developing the T-ARS(X) requirement specification. The CORE design tool is used to implement the MBSE architecting process using the Naval Architecture Elements Reference Guide (NAERG) and standardized operational tasks to create DODAF v1.5 products from system models. The requirements generated from the architecture model are compared with the current, combined towing and salvage-capable commercial platforms for analysis. Based on the methodology presented, the towing and salvage community now has the basis to perform a capabilities-based analysis of alternatives (AoA) for the T-ARS(X) recapitalization.



THIS PAGE INTENTIONALLY LEFT BLANK

# TABLE OF CONTENTS

<b>I.</b>	<b>INTRODUCTION.....</b>	<b>1</b>
	<b>A. SYSTEMS ENGINEERING .....</b>	<b>2</b>
	<b>B. SYSTEMS ENGINEERING PROCESS.....</b>	<b>3</b>
	<b>C. SYSTEMS ARCHITECTURE AND ARCHITECTING .....</b>	<b>6</b>
	<b>1. Systems Architecture .....</b>	<b>7</b>
	<b>2. Systems Architecting .....</b>	<b>8</b>
	<b>D. SYSTEM OF SYSTEMS (SOS).....</b>	<b>9</b>
	<b>E. SYSTEM OF SYSTEMS (SOS) ENGINEERING.....</b>	<b>11</b>
	<b>F. SYSTEMS OF SYSTEMS (SOS) ARCHITECTING.....</b>	<b>12</b>
	<b>G. CAPABILITIES-BASED SYSTEMS DEVELOPMENT .....</b>	<b>13</b>
	<b>H. ARCHITECTURE FRAMEWORKS.....</b>	<b>18</b>
	<b>I. DEPARTMENT OF DEFENSE ARCHITECTURE FRAMEWORK (DODAF) VERSION 1.5 VIEW DESCRIPTIONS .....</b>	<b>22</b>
	<b>J. NAVAL ARCHITECTURE ELEMENTS REFERENCE GUIDE.....</b>	<b>24</b>
	<b>K. CONCLUSION .....</b>	<b>24</b>
<b>II.</b>	<b>UNITED STATES NAVY SALVAGE COMMUNITY .....</b>	<b>27</b>
	<b>A. INTRODUCTION.....</b>	<b>27</b>
	<b>B. SEA 00C.....</b>	<b>29</b>
	<b>C. TOWING AND SALVAGE PLATFORMS .....</b>	<b>32</b>
	<b>D. PLATFORM CHARACTERISTICS.....</b>	<b>35</b>
	<b>E. DECOMPRESSION .....</b>	<b>37</b>
	<b>F. DYNAMIC POSITIONING.....</b>	<b>38</b>
	<b>G. FIREFIGHTING.....</b>	<b>39</b>
	<b>H. BOLLARD LIFT .....</b>	<b>39</b>
	<b>I. BOLLARD PULL .....</b>	<b>40</b>
	<b>J. CENTER FOR NAVAL ANALYSIS (CNA) STUDY .....</b>	<b>41</b>
	<b>K. FUTURE PLATFORM REQUIREMENTS .....</b>	<b>42</b>
	<b>L. SUMMARY .....</b>	<b>43</b>
<b>III.</b>	<b>MISSION ANALYSIS .....</b>	<b>45</b>
	<b>A. BACKGROUND .....</b>	<b>45</b>
	<b>B. DESIGN REFERENCE MISSION (DRM): PROJECTED OPERATIONAL ENVIRONMENT (POE).....</b>	<b>46</b>
	<b>1. Geography .....</b>	<b>47</b>
	<b>2. Maritime Conditions.....</b>	<b>48</b>
	<b>3. Climatic.....</b>	<b>48</b>
	<b>4. Meteorological Date: 04 July 2008 .....</b>	<b>48</b>
	<b>C. DESIGN REFERENCE MISSION (DRM): POTENTIAL SALVAGE TARGETS .....</b>	<b>49</b>
	<b>D. DESIGN REFERENCE MISSION (DRM): CHARACTERISTICS OF SUNKEN VESSEL IN TRANSIT LANE.....</b>	<b>49</b>
	<b>1. Size.....</b>	<b>49</b>

2.	Position.....	50
3.	Depth .....	50
4.	Damage.....	50
E.	DESIGN REFERENCE MISSION (DRM): OPERATIONAL SITUATIONS (OPSIT) .....	51
1.	Discussion.....	51
2.	OPSIT Generation .....	52
3.	Mission Success Requirements .....	54
F.	MISSION DEFINITION .....	54
IV.	ARCHITECTING PROCESS .....	57
A.	INTRODUCTION.....	57
B.	CORE 5 ARCHITECTURE .....	58
C.	ARCHITECTURES.....	60
1.	Operational Architecture .....	61
2.	Operational Nodes .....	61
3.	Operational Activities.....	62
4.	Required Operational Capabilities (ROC).....	64
5.	Operational Task .....	65
6.	Missions.....	68
7.	Systems Architecture Considerations .....	69
8.	Components.....	70
9.	Functions.....	72
10.	Functional Requirements .....	72
11.	Nonfunctional Requirements .....	74
D.	TOWING AND SALVAGE SPECIFIC METHODOLOGY .....	74
E.	SUMMARY .....	76
V.	ARCHITECTURE RESULTS.....	79
A.	DODAF VIEWS.....	79
B.	COMMERCIAL TOWING AND SALVAGE MARKET ANALYSIS....	87
C.	SUMMARY .....	89
VI.	CONCLUSIONS AND RECOMMENDATIONS.....	91
A.	CONCLUSIONS .....	91
B.	RECOMMENDATIONS.....	92
	APPENDIX A .....	95
	LIST OF REFERENCES.....	152
	INITIAL DISTRIBUTION LIST .....	156

## LIST OF FIGURES

Figure 1.	Systems Engineering Process Description (From: DAU, 2001).....	4
Figure 2.	Functional Hierarchy for Conduct Salvage Operations .....	5
Figure 3.	Comparison of Architecting and Engineering (From: Mercer, 2008) .....	9
Figure 4.	New Capabilities-Based Acquisition approach (From: Walker, 2005) .....	14
Figure 5.	Problem and Solution Space for Systems Architecting and Engineering (From: IEEE, 2006) .....	15
Figure 6.	JCIDS Methodology with Joint Concept Development and Revision Plan (From: Walker, 2005) .....	16
Figure 7.	Capabilities-based SE process (From: Whitcomb, 2008).....	18
Figure 8.	Zachman Framework for Enterprise Architecture (From: ZIFA, 2008).....	20
Figure 9.	MODAF Relationships for Acquisition Processes (MODAF, 2006) .....	21
Figure 10.	Linkages Among the AVs (From: DoDAF, 2007) .....	23
Figure 11.	ARS Safeguard class (From: SUPSALV, 2008).....	33
Figure 12.	T-ATF Powhatan class (From: SUPSALV, 2007) .....	34
Figure 13.	The Saturation Fly Away Dive System (SAT FADS) (From: Whaley, 2008) .....	38
Figure 14.	Force needed to pull Navy ships (From: TOWMAN, 1998).....	40
Figure 15.	ARS vs. T-ATF usage (From: Sperling & Keenan, 2006). .....	41
Figure 16.	Map of Gulf of Mexico and New Orleans, Louisiana (From: Google maps, 2008).....	47
Figure 17.	Large fishing vessel aground to simulate mission objective (From: Wikipedia, 2008).....	49
Figure 18.	Location of fishing vessel and mission environment (From: Google maps, 2008).....	50
Figure 19.	DRM OPSIT construct example (From: Skolnick & Wilkins, 2000).....	52
Figure 20.	CORE Approach Relationships from the CORE Architecture Definition Guide [DoDAF version 1.5], (From: Vitech, 2007). .....	59
Figure 21.	CORE DoDAF Schema (From: Vitech, 2007) .....	60
Figure 22.	Architecture element decomposition (From: Vitech, 2007) .....	61
Figure 23.	SEA 00C Operational Node decomposition .....	62
Figure 24.	Operational Architecture Diagram with relations (From: Vitech, 2007).....	62
Figure 25.	CORE systems view of the operational activity “Towing” .....	63
Figure 26.	Task List Hierarchy.....	65
Figure 27.	Mission-Op Task-Op Activity Diagram .....	67
Figure 28.	CORE view of the DRM decomposition .....	69
Figure 29.	System Architecture component/function relationship example (From: Vitech, 2007).....	70
Figure 30.	Ship Work Breakdown Structure (From: MIL-HDBK-881,1998) .....	71
Figure 31.	CORE view of the functional decomposition of “Conduct Salvage Operations” .....	72
Figure 32.	Requirements generation process (From: Vitech, 2007) .....	73
Figure 33.	Methodology for CORE Towing and Salvage architecture development .....	75

Figure 34.	Composite MBSE process .....	77
Figure 35.	CORE integration of the typical systems engineering process with DoDAF views milestones (From: Vitech, 2008).....	80
Figure 36.	SEA 00C SV-2 architecture view .....	81
Figure 37.	“Conduct Towing and Salvage DRM” Hierarchy Diagram .....	82
Figure 38.	“Conduct Towing and Salvage DRM” IDEF0 Diagram.....	83
Figure 39.	“Salvage” IDEF0 Diagram .....	84
Figure 40.	“Conduct Towing Operations” Hierarchy Diagram .....	85
Figure 41.	“Conduct Towing Operations” IDEF0 A-0 Context Diagram.....	85
Figure 42.	“Conduct Towing Operations” IDEF0 Diagram.....	86

## LIST OF TABLES

Table 1.	SoS Engineering vs. SE differences (From: Saunders, 2005) .....	11
Table 2.	Major desirable characteristics of a future towing/salvage ship (From: Sperling & Keenan, 2006) .....	35
Table 3.	Equipage of the four classes displayed in Table 1 (From: Sperling & Keenan, 2006).....	36
Table 4.	Equipage of the four classes displayed in Table 2 (From: Sperling & Keenan, 2006).....	36
Table 5.	DRM assumptions.....	53
Table 6.	OPSIT variables with respective stress levels .....	53
Table 7.	Low-, average-, and high-stress OPSIT scenarios .....	54
Table 8.	SUPSALV Towing and Salvage Platform primary requirements (From: SUPSALV, 2007) .....	73
Table 9.	DoDAF architecture views descriptions (DODAF, 2004).....	79

THIS PAGE INTENTIONALLY LEFT BLANK

## LIST OF ACRONYMS AND ABBREVIATIONS

AFFF	Aqueous Film-Forming Foam
AoA	Analysis of Alternatives
ARS	Auxiliary Rescue Ship
ATF	Auxiliary Tug Fleet
AV	All Views
C4ISRAF	C4ISR Architecture Framework
CADM	Core Architecture Data Model
CBA	Capabilities-Based Assessment
CBP	Capability-Based Planning
CDD	Capability Development Document
CF	Canadian Forces
CIEL	Common Information Elements List
CivMars	civilian merchant mariners
CJCS	Chairman Joint Chiefs of Staffs
CNA	Center for Naval Analysis
COAL	Common Operational Activities List
COCO	Contractor-Owned, Contractor-Operated
CONL	Common Operational Nodes List
CONOPS	Concept of Operations
CSL	Common Systems List
CSFL	Common System Function List
CSNL	Common Systems Nodes List
DAS	Defense Acquisition System
DAU	Defense Acquisition University
DNDAF	Department of National Defense Architecture Framework (Canada)
DODAF	Department of Defense Architecture Framework
DODAF v1.5	Department of Defense Architecture Framework version 1.5
DoD	Department of Defense
DRM	Design Reference Mission
ESL	End of Service Life
ESSM	Emergency Ship Salvage Material
ESWBS	Expanded Ship Work Breakdown Structure
FADS	Fly Away Diving System
FEAF	Federal Enterprise Architecture Framework
ft	feet
FY	Fiscal Year
GO-CO	Government-Owned, Contractor-Operated
GO-GO	Government-Owned and Government-Operated
gpm	gallons per minute
ICD	Initial Capabilities Document
IEEE	Institute of Electrical and Electronics Engineers



INCOSE	International Council on Systems Engineering
JCA	Joint Capability Area
JCIDS	Joint Capabilities Integration and Development System
JMET	Joint Mission Essential Task
JMETL	Joint Mission Essential Task List
JNO	Joint Net-Centric Operations
MBSE	Model-Based Systems Engineering
MCTL	Marine Corps Task List
MDSU	Mobile Diving and Salvage Unit
METL	Mission Essential Task List
MODAF	Ministry of Defence (United Kingdom) Architectural Framework
mph	Miles per hour
MSC	Military Sealift Command
MSFSC	Military Sealift Fleet Support Command
NAVSEA	Naval Sea Systems Command
NAERG	Naval Architecture Elements Reference Guide
NMET	Naval Mission Essential Tasks
NTTL	Navy Tactical Task List
OPSIT	Operational Situations
OV	Operational View
POE	Projected Operational Environment
POSSE	Program of Ship Salvage Engineering
QDR	Quadrennial Defense Review
RFF	Request for Forces
RGS	Requirements Generating System
ROC	Required Operational Capabilities
ROV	Remote Operating Vehicles
RTF	Rich Text Format
SA	Systems Architecting
SAT FADS	Saturation Fly Away Dive System
SCA	System Certification Authority
SCN	Ship New Construction
SDD	System Design Document
SE	Systems Engineering
SEALOGS	Sealift Logistics Commanders
SEP	Systems Engineering Plan
SEP	Systems Engineering Process
Shp	Shaft Horsepower
SME	Subject Matter Expert
SoS	System of Systems
SUPSALV	Supervisor of Diving and Salvage
SUPSALV, NAVSEA 00C	Supervisor of Salvage and Diving
SV	Systems View
SWBS	Ship Work Breakdown Structure

SysML	Systems Modeling Language
SWISS	Shallow Water Intermediate Search Systems
T&E	Testing and Evaluation
TOGAF	The Open Group Architectural Framework
TV	Technical Standards View
TYCOM	Type Command
UJTL	Universal Joint Task List
UNTL	Universal Naval Task List
USD (AT&L)	Under Secretary of Defense, Acquisition, Technology and Logistics
USFF	United States Fleet Forces
USTRANSCOM	Navy Component Commander to the United States Transportation Command
UWSH	Underwater Ships Husbandry
WBS	Work Breakdown Structure
WMA	Warfighting Mission Area
VOO	Vessel of Opportunity

THIS PAGE INTENTIONALLY LEFT BLANK

## EXECUTIVE SUMMARY

The United States Navy has a number of considerations relating to the recapitalization of their ocean-towing and salvage ships, which are in need of replacement within the next 10 to 20 years. The recapitalization alternative acquisition strategies are either building a new platform or purchasing from the commercial market. The motivation for this thesis is to develop a capabilities-driven architecting process, with a model-based systems engineering (MBSE) approach, based on a thorough consideration of capabilities. The architecture model is demonstrated in order to provide a future basis to complete an analysis of alternatives (AoA) that considers new platform options versus acquisition within the commercial market. The end result of this thesis can enable effective decision-making efforts into the recapitalization of the future salvage platform force structure by its stakeholders. Efficient MBSE practices can also prevent the expenditure of resources in areas that may not be feasible in the period of development, thus ensuring a successful, long-term program for future salvage operations. The motivation for a DoD-wide transformation to a capabilities-based systems architecting approach was the realization that systems development consistently resulted in outcomes that did not effectively meet the needs of stakeholders. The integration of architecture-based engineering helps to generate traceable requirements, driven by stakeholder's needs.

“There is a great need to describe a process to ensure that the architecture, the arrangement of elements and their relationships, is well-defined and addresses the needs of the stakeholders” (DODAF, 2004). Architecture frameworks are used by the DoD to provide a consistent documentation basis to describe stakeholder views of a system architecture. To achieve an efficient, integrated system architecture, the needs of all concerned stakeholders and their conflicting ideas of the system outcomes, must be considered. An integration of systems architecting and engineering methods within a model-based process would be useful in developing an interoperable system design based comparative analysis of alternatives opportunities that could be envisioned for future system of systems.

The U.S. Navy Towing and Salvage platform can be architected in the context of a System of Systems (SoS) from an identified set of stakeholder needs. The identification of the salvage platform SoS begins with the mission objectives from the concept of operations (CONOPS) of the salvage force, continues with the development of a design reference mission (DRM), which leads to an appropriate architecture supported by modeling and simulation. A major challenge in the architecting process is developing an architecture so that the system elements are complete and consistent with one another.

The process of identifying capability needs, analyzing system functions, and allocation to system physical components cannot currently be satisfactorily completed given existing architecture framework products alone. The amount of data, when complying with architecture standards such as the Department of Defense Architecture Framework (DoDAF), is too large to manipulate manually. An architecting tool is a great asset that is used to verify that the data is consistent and that all element connections remain with their associated counterparts. The CORE Architecture Data Model (CADM) can aid in this task by integrating the architectural frameworks within the SoS development process and the Systems Modeling Language (SysML) representation of the SoS model. The development of the CORE architecting method can define the future salvage platform SoS and adequately identify the capability-based requirements from the operational mission objectives. CORE can provide a clear path from mission area needs to a set of clear and defined requirements; achieving a product able to perform both towing and salvage operations.

This thesis reports the development of an architecting process that directly addresses the recapitalization of a future towing and salvage ship platform, preemptively named T-ARS(X), with the development of both legacy T-ARS and T-ATF capabilities. The model-based system architecture process utilizes CORE modeling techniques to achieve top-level coherent requirements to be used in an analysis of the commercial market capabilities, and will be used as a foundation for future capability-based architectural modeling. The architecture developed in this thesis demonstrates a way forward for a complete T-ARS(X) system model with further development to include all T-ARS(X) operational tasks, components, mission areas and capabilities.

## **ACKNOWLEDGMENTS**

I would like to extend my gratitude to all those who supported me in my completion of this thesis. Special thanks to my thesis advisors, Dr Cliff Whitcomb and Dr. Fotis Papoulias, for the very helpful feedback and guidance throughout the program and on this thesis. Very special thanks go to my cohorts, who have collaborated with me throughout the program and from whom I have learned a very great deal. Thank you also to all those who have provided suggestions for improving draft chapters, especially LT Robert Williams, and LT Judd Southworth. Finally, and most importantly, my sincere thanks go to my family, for their support through my education at the Naval Postgraduate School.

THIS PAGE INTENTIONALLY LEFT BLANK

## I. INTRODUCTION

The United States Navy has a number of considerations relating to the recapitalization of their ocean-towing and salvage ships. Currently, the Navy operates four towing (T-ATF) and four salvage (ARS) ships that are in need of replacement within the next 10 to 20 years. The need for ARS and T-ATF recapitalization has been verified and alternative acquisition strategies, such as building a new platform or purchasing from the commercial market, are being entertained (Sperling & Keenan, 2006).

Up to nine replacement ARS/T-ATF ships, with a consideration to move to a single-hull T-ARS(X), are needed to fulfill the combined peacetime and wartime requirements described in the ARS and T-ATF Concept of Operations (CONOPS). This requirement was verified by United States Fleet Forces (USFF), Center for Naval Analysis (CNA), and Naval Sea Systems Command (NAVSEA), based on current mission needs and the CONOPS of the towing and salvage ships of the Navy (Sperling & Keenan, 2006). Analysis of alternative (AoA) possibilities to meet the Navy's towing and salvage requirements include building a new ship, purchasing commercial platforms, or a combination of both. For the alternative investment strategy of purchasing commercial platforms, a contractor-owned contractor-operated (COCO) option has been demonstrated by CNA to be more cost effective, based on current towing and salvage requirements (Sperling & Keenan, 2006). In order to consider stakeholder needs in the decision-making process for such a future Fleet investment, a study of the architecture of the elements involved, and their relationships, should be conducted. The ocean-towing and salvage capability is a System of Systems (SoS) and the need to define an adequate architecture is key to identifying the top-level requirements that are crucial in determining which investment strategy the Navy should consider.

The motivation for this thesis is to develop a capabilities-driven architecture development process, integrated into a model-based systems engineering methodology, and to demonstrate a thorough consideration of capabilities to develop the basis for an AoA that considers requirements for both new platform options as well as COCO assets from the commercial market. Key outcomes described in this thesis are:



- An architecture and architecture-based requirements generation process (with focus on stakeholder needs) ideally suited to future salvage platform force structure development.
- A model-based systems engineering (MBSE) process that integrates architecting principles, from engineering requirements definition to physical architecture integration, for fusing the diverse assets involved in this complex system (Whitcomb, 2008).
- A set of architectural and realizable requirement specifications based on the salvage community's needs.
- An architecture based on capabilities mapped to mission activities.
- A market analysis of the COCO possibilities against requirements.

The end result is a method that enables effective decision-making efforts for the recapitalization of the “Future Salvage Platform Force Structure,” as well as preventing the expenditure of resources in areas that may not be feasible in the period of development, thus ensuring a sound basis of architecture for the future salvage fleet (Whitcomb, 2008).

The development of this model-based methodology requires consideration of many newly architectural aspects of systems – from systems engineering and architecting, capabilities-based planning, SoS, and architectural elements. A brief review of topics is presented in order to set the context for the description of the final model-based methodology in this thesis.

## **A. SYSTEMS ENGINEERING**

Systems engineering is generally used to describe the set of processes applied to the development of a system that consists of two significant disciplines: the technical knowledge domain in which the systems engineer operates, and systems engineering management (DAU, 2001). Systems engineering spans the progression from customer need discovery to the disposal of the system. “A system is an integrated group of separate entities which interact to perform a function” (DAU, 2001). This integrated group embodies a set of relationships among the composite of people, products, and

processes, providing a capability to satisfy a stated need or objective (DAU, 2001).

Systems engineering is defined as

. . . a branch of engineering whose responsibility is creating and executing an interdisciplinary process to ensure that customer and stakeholder's needs are satisfied in a high quality, trustworthy, cost efficient and schedule compliant manner throughout a system's entire life cycle, from development to operation to disposal (INCOSE, 2008).

Systems engineering provides the processes to define system performances, costs, schedule, and risks.

In 2004, the Under Secretary of Defense for Acquisition, Technology, & Logistics (USD AT&L) issued a Policy for Systems Engineering in the Department of Defense (DoD) to "drive good systems engineering processes and practices back into the way we do business." The engineering process used in this thesis is an iterative development process of a system, with consideration for the needs of the towing and salvage community.

## **B. SYSTEMS ENGINEERING PROCESS**

The Systems Engineering Process (SEP) is a comprehensive, iterative and recursive problem solving process, applied sequentially top-down by integrated teams. It transforms needs and requirements into a set of system product and process descriptions, generate[s] information for decision makers, and provides input for the next level of development. The systems engineering process, displayed in figure 1, is applied sequentially, one level at a time, adding additional detail and definition with each level of development (DAU, 2001).

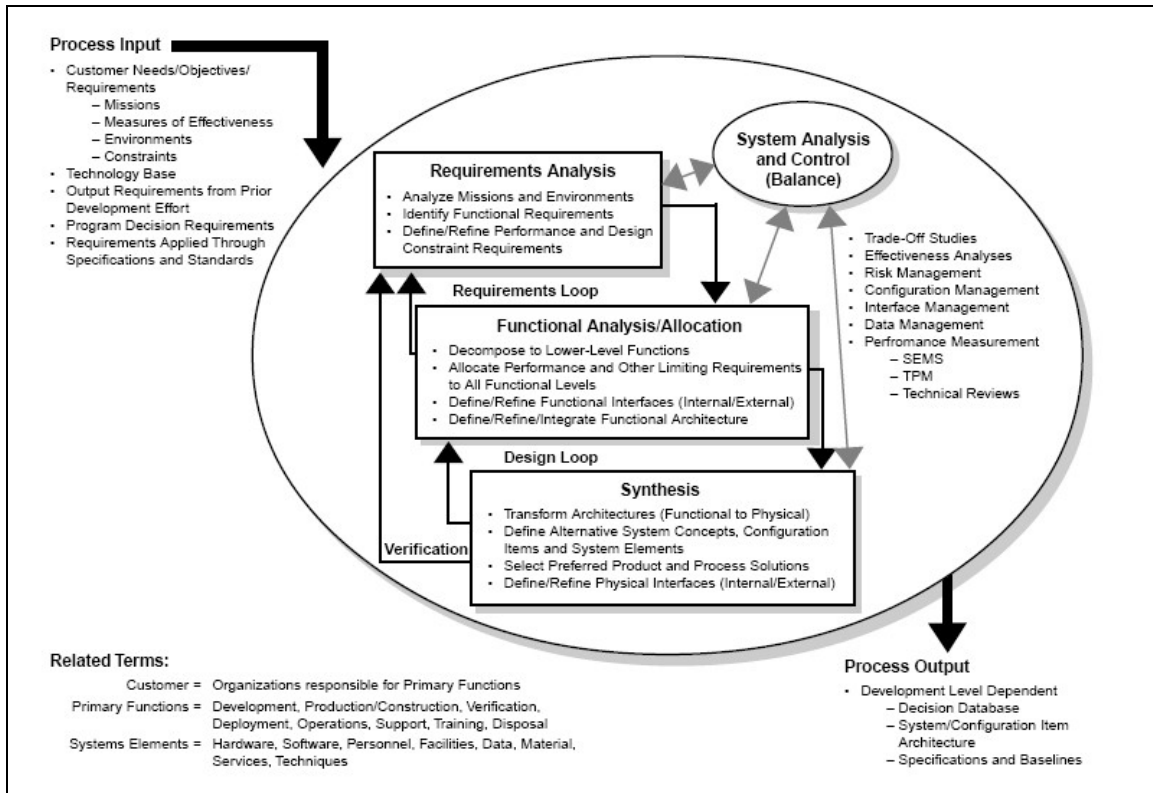


Figure 1. Systems Engineering Process Description (From: DAU, 2001)

A typical systems engineering process begins with identifying the initial problem statement and list of stakeholders. After confirmation that there is a need to solve the problem, the next step is to refine and reiterate the problem statement, confirm the coordination between all important stakeholders, and to analyze the process inputs. Systems engineering process inputs consist primarily of the customer’s needs, objectives, requirements, and project constraints.

Next, a requirements analysis is accomplished and is used to develop complete and understandable set of performance requirements that define what the system must do and how well it must perform. These requirements are based on customer needs.

Requirements analysis must clarify and define functional requirements and design constraints. Functional requirements define quantity (how many), quality (how good), coverage (how far), time lines (when and how long), and availability (how often). Design constraints define those factors that limit design flexibility, such as: environmental conditions or limits; defense against internal or external threats; and contract, customer or regulatory standards (DAU, 2001).

Once the requirements have been identified and defined, they need to be mapped to functions, which must be analyzed and allocated into lower-level functions. Higher-level functions can be analyzed by decomposing them into lower-level functions. “The result is a description of the product or item in terms of what it does logically and in terms of the performance required” (DAU, 2001). Lower-level functions derived from higher-level functions, presented within a functional hierarchy diagram and displayed in Figure 2, provide a better understanding of what the actual functions are and how they are associated with each other. This description is called a functional architecture and provides “information essential to optimizing physical solutions” (DAU, 2001).

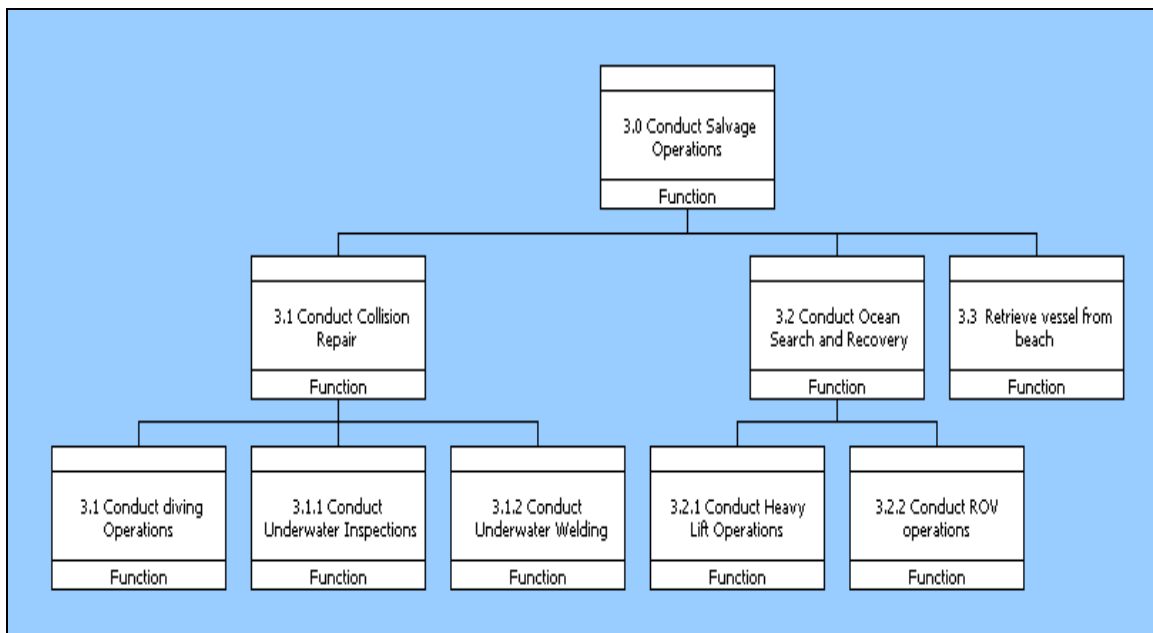


Figure 2. Functional Hierarchy for Conduct Salvage Operations

After all functions have been identified, each must then be matched to a requirement for use in developing the physical architecture initialization through design synthesis. Design synthesis is the process of defining the physical architecture of the system in terms of its physical elements. Each physical element must meet at least one functional requirement. “The physical architecture is the basic structure for generating the specifications and baselines” (DAU, 2001). During the physical architecture synthesis, it is consistently aligned with the functional architecture, eventually with physical system performance verified to the requirements in a design loop. “The design

loop permits reconsideration of how the system will perform its mission, and this helps optimize the synthesized design” (DAU, 2001). The verification process is a formal testing and evaluation procedure for ensuring that all requirements will be met by the proposed solution.

The set of systems analysis and control process is used to evaluate the system’s design and alternative approaches during each phase of the systems engineering process.

The purpose of Systems Analysis and Control is to ensure that solution alternative decisions are made only after evaluating the impact on system effectiveness and that product and process design requirements are directly traceable to the functional and performance requirements they were designed to fulfill (DAU, 2001).

Once the system functions have been traced to the system requirements, the next phase is to design the system configuration and begin baseline definition. For DoD, system output is “any data that describes or controls the product configuration or the processes necessary to develop that product” (DAU, 2001).

One of the most important characteristics of the systems engineering process is synergy. Identifying the interactions of all components of a system, in the sense that the composite or total system achieves more than the component systems, can achieve greater efficiency in the development that suits the ever-evolving nature of complex systems. The need to accommodate evolving systems requires the development of appropriate architectural infrastructures through a process that includes aspects of both architecture and engineering.

### **C. SYSTEMS ARCHITECTURE AND ARCHITECTING**

The early-stage activities involved in systems engineering have salient features more related to the field of architecture than that of engineering. The difference between architecting and engineering is described in terms of “art and science” (Rectin & Maeir, 2002). Architecting focuses on the architecture, or art, and patience of a designer necessary to complement the complexity of engineering the system. Architecting contrasts with engineering in that it is “nonanalytic, difficult to clarify, and seldom taught formally in industry” (Rectin & Maeir, 2002). Architecting plays a vital role in creating

new types of complex systems that incorporate evolving technologies (Rechtin & Maier, 2002). The need for architecting is shown in that it complements engineering in accounting for the immeasurable: e.g., multiple stakeholders, perceptions of worth, safety, affordability, political acceptance, and environmental impact. Therefore, the development of an architecture in the earliest stages of a systems engineering process is justified.

## **1. Systems Architecture**

In 1987, John Zachman, author of the *Zachman Framework for Enterprise Architecture*, wrote “To keep the business from disintegrating, the concept of information systems architecture is becoming less of an option and more of a necessity.” From that statement, systems architecture has evolved and become the model around which major organizations view and communicate their enterprise information infrastructure (ZIFA, 2008).

There is no universally agreed on definition of a systems architecture. Various organizations define it in different ways, including:

- The arrangement of elements and subsystems and their functional allocation to meet system requirements (INCOSE, 2008).
- The arrangement of the functional elements into physical blocks (Ulrich & Eppinger, 2004).
- The arrangement of function and feature that maximizes some objective (Ring, 2001).
- The embodiment of concept, and the allocation of physical/informational function to elements of form and definition of structural interfaces among the elements (Crawley, 2003).
- The structure (in terms of components, connections, and constraints) of a product, process, or element (Rechtin & Maier, 2002).
- The structure of components, their relationships, and the principles and guidelines governing their design and evolution over time (DoDAF, 2007).

In business, outside of DoD, “an architecture description is a formal description of a system, organized in a way that supports reasoning about the structural properties of the system. It defines the system components and provides a plan from which products can

be procured. It thus enables you to manage investment in a way that meets business needs” (TOGAF, 2007).

An architecture, then, is an organized set of interconnected system capabilities, functions, and components; their relationships to each other, and to the environment; and the principles guiding its design and evolution (IEEE STD 1471, 2000). Typically, an architecture is developed because key people (stakeholders) within the organization have concerns that need to be addressed by the systems. The role of the architect is to address these concerns (Whitcomb, 2008):

- Identifying and refining the stakeholder requirements.
- Developing architectural views and models that show how the concerns and the requirements are going to be addressed.
- Showing the trade-offs that are going to be made in reconciling the potentially conflicting concerns of different stakeholders.

The system architect develops the architecture early in the systems engineering process.

## **2. Systems Architecting**

Architecting deals primarily with undefined situations with immeasurable quantities, focusing on the qualitative aspects of the system. Engineering deals primarily with physical and scientific situations with measurable quantities and concepts, using analytic tools, making it compatible with the beginning stages of the systems engineering process (Maier & Rechtin 2002). Figure 3 presents a summary of the characteristic differences between architecting and engineering.

Systems architecting (SA) employs synthesis of form to iteratively compose separate elements to form a coherent whole, or a representation of a coherent whole, that can serve as an initial point for systems development. Architecting synthesizes this initial point or architectural specification from the collected vision, goals, constraints, and other needs of the stakeholders in the to-be-developed system. Architecture specification can be defined as an architectural description to which all system implementations must adhere; and a set of principals, practices, and constraints guiding implementation, operation, and evolution of the developed system (Mercer, 2008).

Systems architecting and systems engineering are often described in a single systems engineering process, typically because systems architecting is not addressed individually, but is simply defined by the steps used in the very early stage of the process. Architecture exists for the purpose of (a) achieving a well-defined system in the application domain, and (b) achieving the eventual system developed in the solution domain, that (c) can be used to meet desired capabilities over a specific time frame or set of time frames. The act of creating an architecture is fundamentally different from the act of creating a product through engineering.

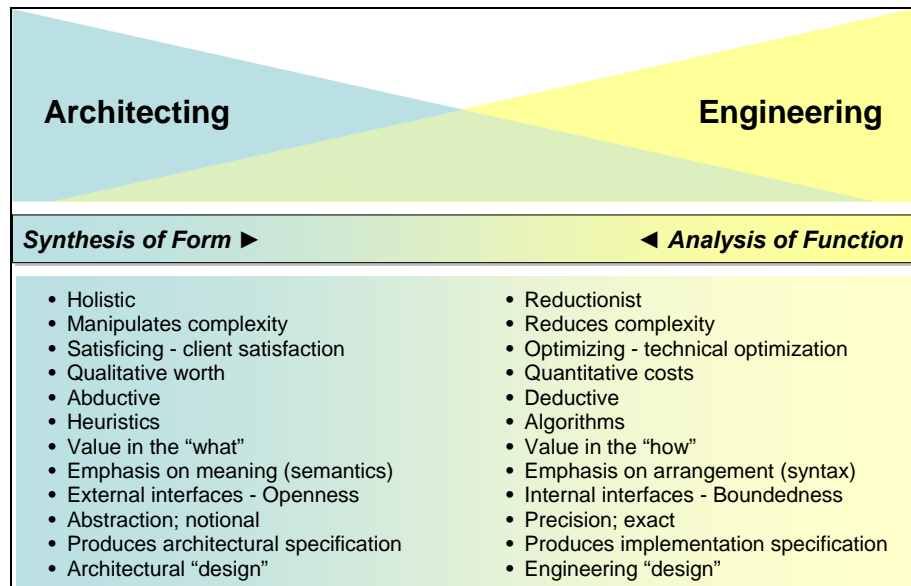


Figure 3. Comparison of Architecting and Engineering (From: Mercer, 2008)

#### D. SYSTEM OF SYSTEMS (SoS)

The concept of systems has been recently expanded to directly define “SoS” as unique from “systems.” An SoS is defined as “a set or arrangement of systems that results when independent and useful systems are integrated into a larger system that delivers unique capabilities” (JCIDS 2005). The SoS concept does not specify a need for particular new methods; instead, it suggests a new way of thinking for solving complex interactions of technology, policy, and economics. “System of systems study is related to the general study of architecting, complexity and systems engineering, but also brings to the forefront the additional challenge of design” (DeLaurentis, 2007).



The basic needs to accommodate system life-cycle changes are identified as: systems engineering organization for life-cycle management, developing appropriate infrastructures, and adopting a systems management paradigm for SoS evolution to ensure interoperability. Appropriate architecting is suggested as a major need to ensure this (Boardman & Sauser, 2008). There have been a number of other similar characterizations. For example, Sage and Biemer (2007) provide the following five characteristics differentiating an SoS from monolithic systems:

- Autonomy – constituent systems exercise autonomy in order to fulfill the purpose of the SoS.
- Belonging – constituent systems choose to belong to the SoS, based on cost/benefits basis.
- Connectivity – constituent systems provide dynamic connectivity to enhance overall SoS capability.
- Diversity – a product characteristic of an SoS not available from single systems.
- Emergence – capability is provided that was not originally foreseen during development, leading to early detection and elimination of undesirable behaviors.

Following the stated characteristics, an SoS is defined by Boardman and Sauser (2008) as

. . . a large-scale, complex system, involving a combination of components which are systems themselves, achieving a unique end-state by providing synergistic capability from its component systems, and exhibiting a majority of the following characteristics: operational and managerial independence, geographic distribution, emergent behavior, evolutionary development, self-organization, and adaptation.

Sage and Biemer (2007) summarize the concept of defining an SoS by identifying five typical characteristics of a system family:

- A[n] SoS is composed of systems that are independent and useful in their own right.
- The component systems in an SoS not only *can* operate independently; they generally *do* operate independently to achieve an intended purpose.
- The geographic dispersion of the component systems is often large.
- A[n] SoS performs functions and carries out purposes that are not necessarily associated with any component system, leading to behaviors

that are emergent properties of the entire SoS and not the behavior of any component system.

- The development of an SoS is generally evolutionary over time.

Given the above definition of SoS, the connection between integrated architectures and an SoS is presented in the context of this thesis.

### E. SYSTEM OF SYSTEMS (SoS) ENGINEERING

Conducting SoS is quite similar to conducting systems engineering (SE), though “the development of a system of systems solution will involve trade space between the systems, as well as within an individual system’s, performance” (DAG, 2006). Table 1 displays the differences between traditional SE and the SoS engineering process.

	<b>Traditional Systems Engineering</b>	<b>System-of-Systems Engineering</b>
<b>Purpose</b>	Development of single system to meet stakeholder requirements and defined performance	Evolving new system-of-systems capability by leveraging synergies of legacy systems
<b>System Architecture</b>	System architecture established early in lifecycle and remains relatively stable	Dynamic reconfiguration of architecture as needs change; use of service oriented architecture approach as enabler
<b>System Interoperability</b>	Defines and implements specific interface requirements to integrate components in system	Component systems can operate independently of SoS in a useful manner Protocols and standards essential to enable interoperable systems
<b>System “ilities”</b>	Reliability, Maintainability, Availability are typical ilities	Added “ilities” such as Flexibility, Adaptability, Composeability
<b>Acquisition and Management</b>	Centralized acquisition and management of the system	Component systems separately acquired and continue to be managed as independent systems
<b>Anticipation of Needs</b>	Concept phase activity to determine system needs	Intense concept phase analysis followed by continuous anticipation, aided by ongoing experimentation

Table 1. SoS Engineering vs. SE differences  
(From: Saunders, 2005)

“SoS Engineering (SoSE) is an emerging interdisciplinary approach focusing on the effort required to transform capabilities into SoS solutions and shape the requirements for systems” (SOSCE, 2008). SoS engineering ensures that:

- Individually developed, managed, and operated systems function as autonomous constituents of one or more SoSs, and provide appropriate functional capabilities to each of those SoSs (SOSCE, 2008).
- Political, financial, legal, technical, social, operational, and organizational factors, including the stakeholders’ perspectives and relationships, are considered in SoS development, management, and operations (SOSCE, 2008).
- An SoS can accommodate changes to its conceptual, functional, physical, and temporal boundaries without negative impacts on its management and operations (SOSCE, 2008).
- An SoS collective behavior, and its dynamic interactions with its environment to adapt and respond, enables the SoS to meet or exceed the required capability (SOSCE, 2008).

“SoS Engineering is the discipline for the design, development, deployment, operation, and modifications of SoS” (SOSCE, 2008). In particular, SoS Engineering addresses the challenges involved with the integration of independent systems with a common function. “SoS Engineering spans the lifecycle of the SoS, potentially meeting constituent systems through different phases of their individual lifecycles. It acts on the SoS as the object of engineering effort, setting the environment and defining relationships for further analysis and engineering at the individual system level for constituents” (SOSCE, 2008).

## **F. SYSTEMS OF SYSTEMS (SoS) ARCHITECTING**

The role of SoS architecting in the SE process is to integrate functional architecture within the functional analysis/allocation design loop. The necessary architecting paradigm is not present within the Institute of Electrical and Electronics Engineers (IEEE), Defense Acquisition University (DAU), and EIA-632 SE processes.

The architecting of an SoS starts with the transformation of an operational capability need into a set of requirements, which are used to guide the development of functional and physical architectures through design (Whitcomb, 2008). The development of functional architectures will bridge the gap between the stakeholders’ needs and an understandable functional breakdown structure of the collected requirements.

## **G. CAPABILITIES-BASED SYSTEMS DEVELOPMENT**

The DoD is in the process of implementing a capabilities-based requirements-to-resources system. “This transformation of the requirements generation and resourcing processes holds promise for delivering more warfighting capabilities to the Combatant Commanders in a resource constrained environment” (Walker, 2005).

The DoD directed the initiation of a capabilities-based approach to defining defense requirements (Walker, 2005). The emphasis was placed on delivering capabilities to address a wide range of mission objectives of the future towing and salvage platform(s). As stated by Donald Rumsfeld, the switch to capabilities-based architecting is pertinent in achieving the future mission objectives of all U.S. military systems:

A central objective of the Quadrennial Defense Review was to shift the basis of defense planning from a ‘threat-based’ model that has dominated thinking in the past, to a ‘capabilities-based’ model for the future. This capabilities-based model focuses more on how adversaries fight, rather than specifically whom the adversary might be or where a war might occur. It recognizes that it is not enough to plan for large conventional wars in distant theaters. Instead, the United States must identify the capabilities required in order to defeat adversaries who will rely on surprise, deception, and asymmetric warfare to achieve their objectives (Rumsfeld, 2007).

A major factor that could inhibit the future salvage platform from meeting its full potential is that the proposed top-level characteristics are requirements driven, with the initial designer having a preconceived notion of the solution. The method of developing systems referred to by Secretary Rumsfeld, as well as the new systems development process, called the Joint Capabilities Integration Development System (JCIDS), is shown in Figure 4.

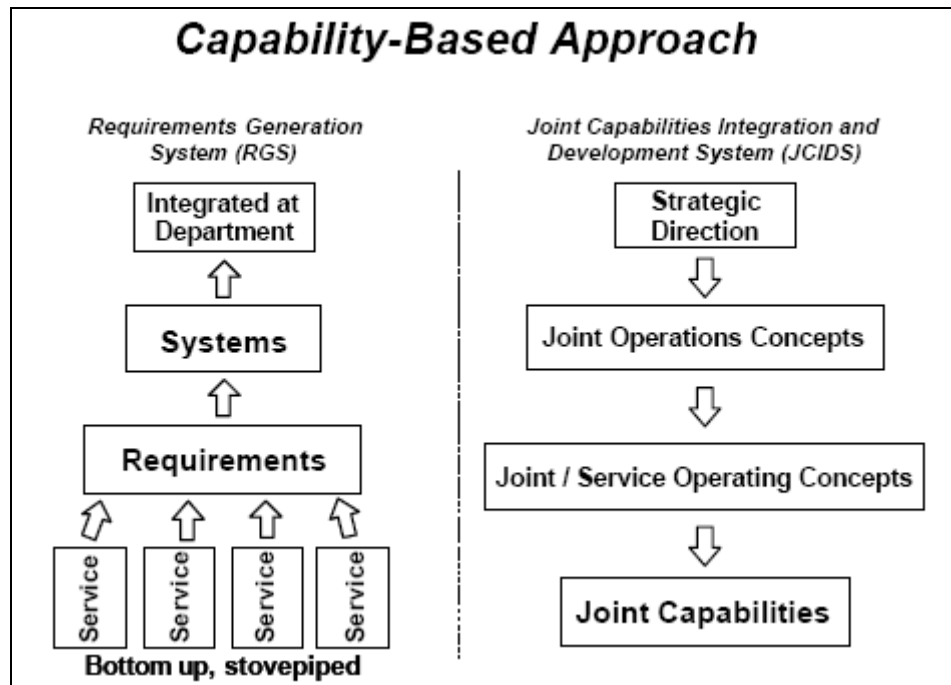


Figure 4. New Capabilities-Based Acquisition approach (From: Walker, 2005)

The left-hand side of Figure 4 represents a simplified version of the old Requirements Generation System that Secretary Rumsfeld alluded to (Walker, 2005). The old method concentrated on generating requirements in order to fulfill their “idea” of warfighting. These required capabilities were derived within a system where joint service contributions were ignored. The new capability-based planning approach is represented on the right-hand side of Figure 4. Instead of trying to generate interservice requirements, based on joint service capabilities, at the end of the process, the new approach inverts the paradigm, concentrating on the capabilities of the joint services at the beginning of the process (Walker, 2005).

The use of capabilities-based planning has proven beneficial to certain companies. Analogous to DoD’s approach to generating military requirements, represented in Figure 4, commercial industries that have determined what logistics infrastructure capabilities were required, compared to those who have used the approach of generating requirements, have had major success (Walker, 2005). Identifying processes that provide the capability needed by the customer can be identified with an SoS architecture framework within the SE process model.

An architecting process can provide the capabilities needed by pulling the requirements based on mission need, and by focusing on the problem rather than the solution. Figure 5 identifies a set of problem space domains that must be addressed, prior to focusing on the solution space or the generation of requirements. The problem space identifies the functions within each component of a system. The functions were derived based on the mission need and CONOPS, and will be used to identify the capability of the system needed to successfully complete that mission.

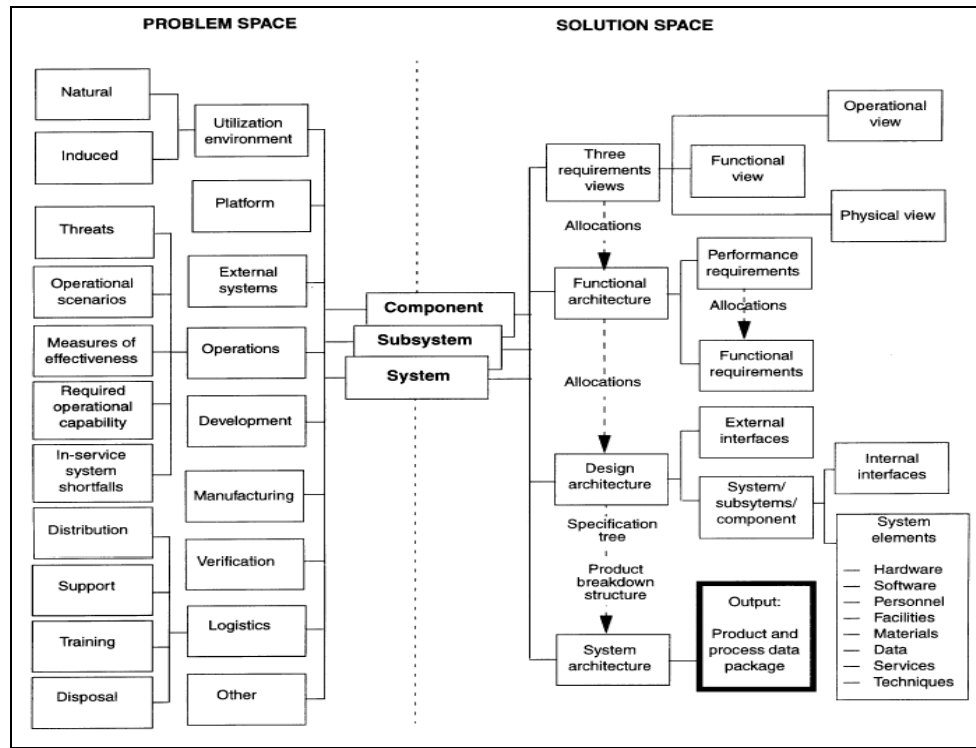


Figure 5. Problem and Solution Space for Systems Architecting and Engineering (From: IEEE, 2006)

The architecting process must include the ability to allow for an iterative process of discovery in meeting emerging capability needs as they arise. Implementation of this capability-based development process is the front-end to the system acquisition and development process, and is an attempt to provide a sound basis for beginning a systems engineering approach to development by keeping the early stage process focused on the problem space and not the solution space (Whitcomb, 2008).

“A Capabilities-Based Assessment (CBA) is conducted to identify capability needs, capability gaps, capability excesses, and approaches to provide needed capabilities

within a specified functional or operational area” (CJCSI 3170.01C, 2007). According to the CJCSI 3170.01F Glossary (2007), a capability need is defined as “a capability that is required to be able to perform a task within specified conditions to a required level of performance.” A capability gap is what results from the

. . . inability to achieve a desired effect under specified standards and conditions through combinations of means and ways to perform a set of tasks. The gap may be the result of no existing capability, lack of proficiency or sufficiency in existing capability, or the need to recapitalize an existing capability (CJCS Instruction 3170-01F and CJCS Manual 3170-01C, 2007).

The JCIDS is one component of the capability-based planning (CBP) process that the DoD uses as its principal decision support process for transforming the military to support the national military and defense strategy. JCIDS plays a key role in identifying the capabilities required by the warfighters to support the national defense strategy and the national military strategy. The procedures established in the JCIDS identify, assess, and prioritize joint military capability needs as specified in Figure 6 (JCIDS, 2007).

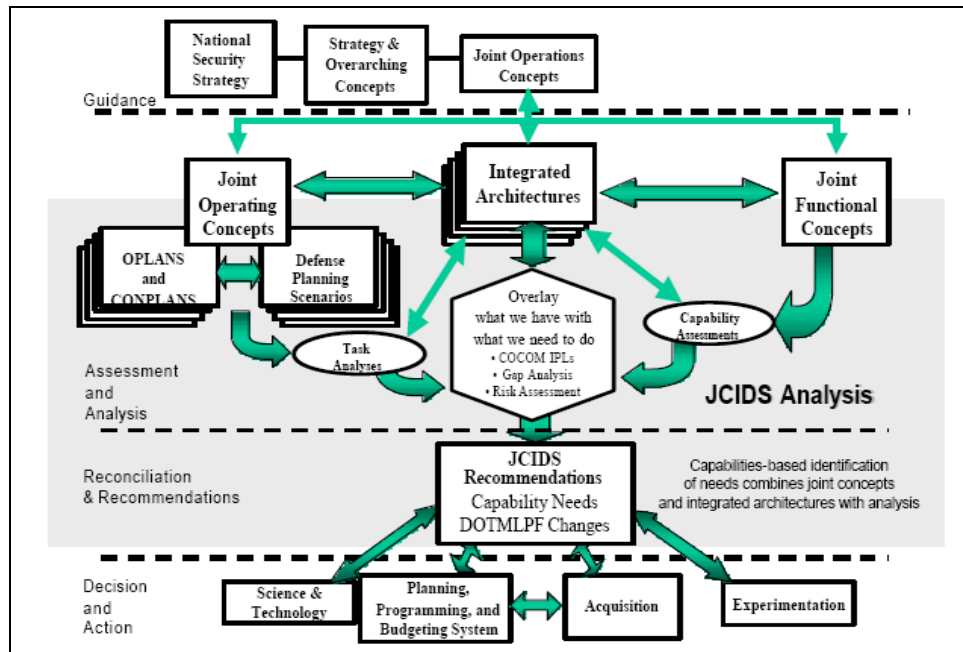


Figure 6. JCIDS Methodology with Joint Concept Development and Revision Plan (From: Walker, 2005)

The JCIDS implements a capabilities-based methodology that “leverages the expertise of all government agencies to identify improvements to existing capabilities and to develop new warfighting capabilities” (CJCSI 3170.01F, 2007). This approach requires a collaborative process that utilizes joint concepts and integrated architectures to identify prioritized capability gaps and integrated policy approaches to resolve those gaps (JCIDS, 2007).

The evolving Joint Concept Development and Revision Plan identified in Figure 6 is “a description of how a Joint Force Commander 10-20 years in the future will integrate capabilities to generate effects and achieve an objective” (Walker, 2005). Once the required capabilities (what we want to be able to do) are identified, the JCIDS process is intended to assess our capacity to fulfill those capabilities.

Systems architecting and SE present complementary approaches to the development of an SoS. For capability-based development of unprecedented systems, the initial portions of the traditional SE process have been demonstrated to show unsatisfactory results, in particular due to the complexity in transforming ill-defined capabilities into requirements useful enough to begin any engineering-based design. A capability is defined as “the ability to achieve a desired effect under specified standards and conditions through combinations of means and ways to perform a set of tasks” (IEEE, 2006). “Capabilities, often referred to as operational scenarios, consist of a sequence of operational activities needed to respond to or to provide an external stimulus” (Whitcomb, 2008). Figure 7 displays the typical SE process, with the capabilities-based development process incorporated to include a capability pull feedback loop. This will ensure customer capability needs are continuously being addressed and revised throughout the SE process.

While recognition of focus on capabilities-driven systems architecting has given rise to the fairly recent development of system architecting methods, frameworks, and processes, what is lacking at this time is a defined method for architecting—the development of the architecture itself (Whitcomb, 2008).



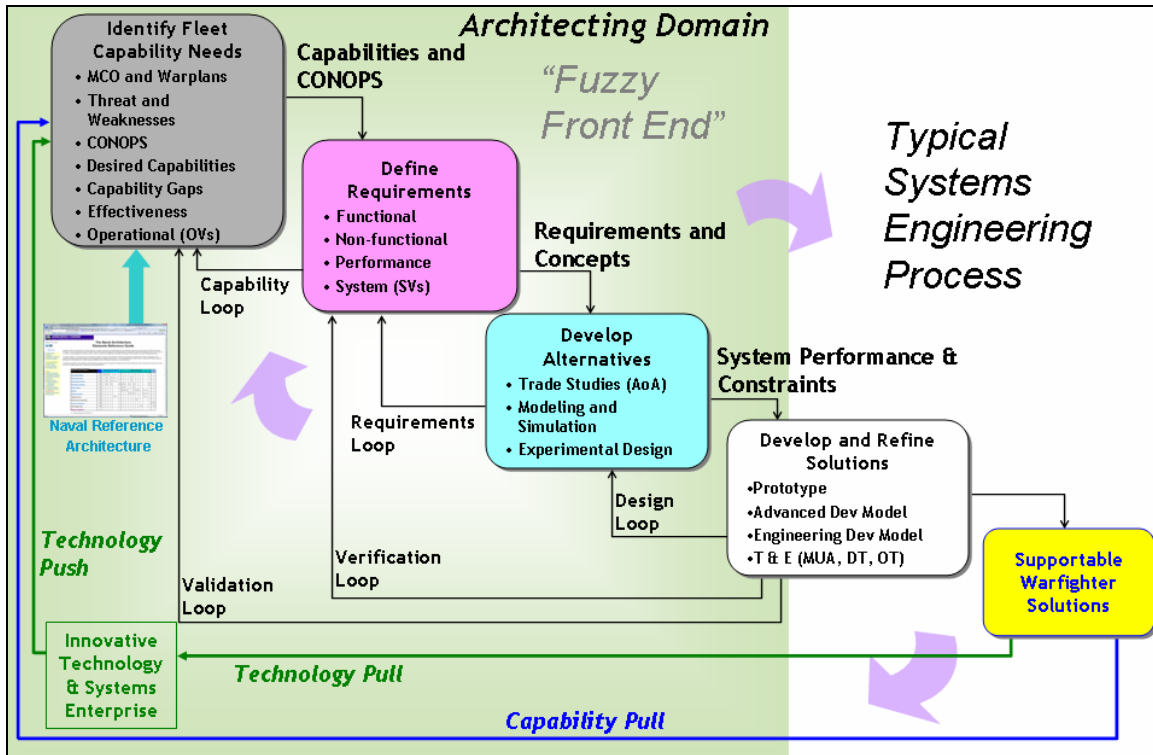


Figure 7. Capabilities-based SE process (From: Whitcomb, 2008)

The outcome of this process is the fundamental description of the basis for the system—its architecture. This architecture defines the elements, their relationships, and the principles guiding its design and evolution. This architecture must be made visible to all system stakeholders, since it is the first embodiment of the system that can be reasoned about. This is accomplished through frameworks.

## H. ARCHITECTURE FRAMEWORKS

It is typical for engineers to treat the development of systems similar to the development of more basic commercial consumer products—by attempting to describe the total system down to the individual component. Without putting tight bounds on the engineering task, the engineer would develop descriptive information that would keep expanding toward the total system description. In a systems architecting approach, the development of the architecture takes the place of the description of components. There now exists a need to be able to articulate the relationships of the elements of the architecture, and this is done through architecture views in frameworks.

The architectural views of a framework set well-defined boundaries for a given aspect of the system while reassuring the engineering team that the full architectural description will serve to describe the system in full. The use of frameworks provides a comfortable environment for the systems team to conquer the complex system (Richards et al., 2007).

The large amount of information associated with an architecture is best considered within a structure or framework, in which it can be interrelated, manipulated, and displayed. Architecture frameworks are tools for coping with system complexity by structuring data into views with a common language, and are used to provide a consistent documentation basis to describe a system's characteristics (DoDAF, 2007). The Department of Defense Architecture Framework (DoDAF) is the standard systems architecture used within the United States military. DoDAF version 1.5, published in April 2007, is the current architecture framework guidance, with version 2.0 to be released soon (DoDAF, 2007).

The Zachman framework, originated by John Zachman, is considered canonical, as it set the standard for a philosophy for classifying a system architecture. The intent of the Zachman framework is to establish a common vocabulary that defines complex enterprise systems. The Zachman framework classifies and organizes the design artifacts created in the process of designing and producing complex systems (Sessions, 2007). The Zachman institute developed a framework design to capture the nuances of enterprise architecting displayed in Figure 7.

It uses a two dimensional classification model based on the six basic interrogatives (What, How, Where, Who, When, and Why) intersecting six distinct perspectives, which relate to stakeholder groups (Planner, Owner, Designer, Builder, Implementer and Worker). The intersecting cells of the Framework correspond to models which, if documented, can provide a holistic view of the enterprise (Sessions, 2007).

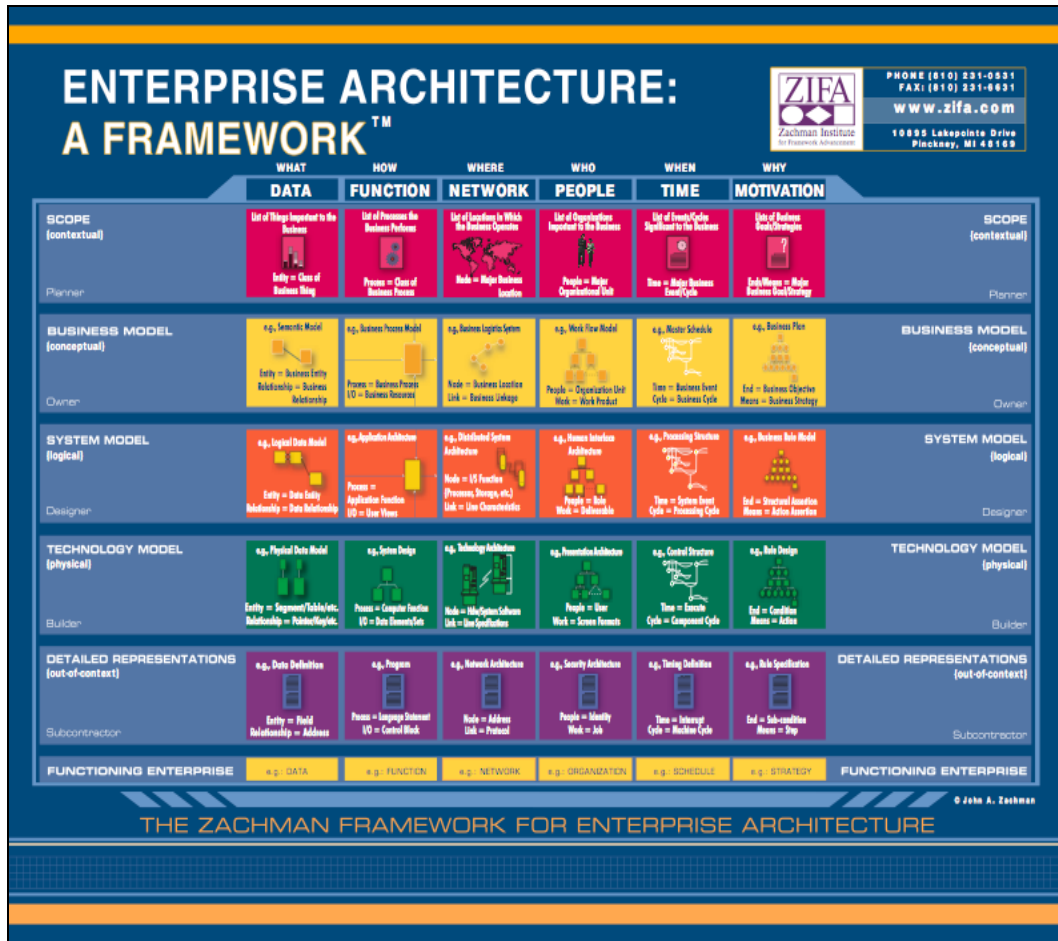


Figure 8. Zachman Framework for Enterprise Architecture (From: ZIFA, 2008)

All DoD weapons and information technology system procurements are required to develop and document a systems architecture using the views prescribed in the DoDAF (AFF, 2008). The DoDAF was originally designed based on the Zachman framework and is suited to organize large systems with complex integration and interoperability challenges. Similar architecture frameworks are the Ministry of Defence (United Kingdom) Architecture Framework (MODAF), the Canadian Forces (CF) Architecture Framework (DNDAF). Along with the DoDAF, the MODAF and DNDAF are organized around a shared repository to hold work products (AFF, 2008).

“The overall objective of architecture frameworks is to improve the ability of the system acquirer, builder, and user to make technical decisions” (Richards et al., 2007). The motivation for the development of an architecture framework was the desire to capture systems information in a manner that enriched the overall system description.

Architecture frameworks are further evolutions of this essential need to develop system descriptions that are complete, correct, coherent, and usable for multiple stakeholders in the development of systems (Richards et al., 2007). DoDAF version 1.5 is a descriptive methodology for capturing high-level system information using three views: Operational View (OV), Systems View (SV), and Technical Standards View (TV). An additional view, the All View (AV) (introduced in version 1.5), is an overview and summary document of the architecture.

The relationship of architectural products of a capabilities-based acquisition process is shown in Figure 9 (Biggs, 2005). This MODAF diagram can also be found in similar form in the DoDAF and DNDAF documents, which, in turn, were developed from the Zachman framework (ZIFA, 2008). The chief difference between the MODAF and the DoDAF is the inclusion of the Strategic View (StV) in the MODAF. This is important, as the StV captures the capability view (Whitcomb, 2008).

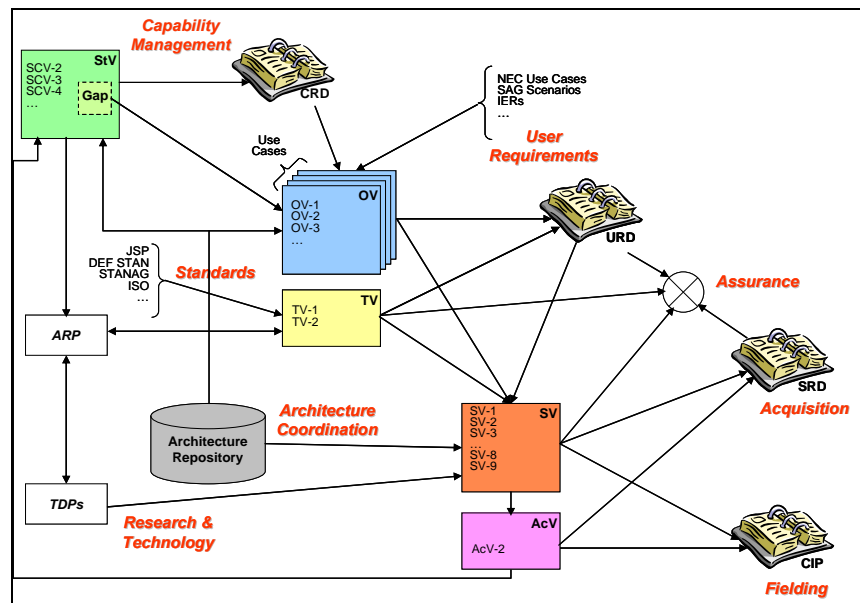


Figure 9. MODAF Relationships for Acquisition Processes (MODAF, 2006)

The DoDAF, MODAF, and DNDAF define a common approach for architectural description, development, presentation, and integration (Huynh & Osmundson, 2007). Recent evidence collected by the DoD suggests that there is a gap between the intended use of architecture frameworks in acquisition and their deployment in industry (OASDNII, 2005). For example, the Joint Net-Centric Operations (JNO) end-to-end

delivery is currently suboptimally managed to provide a synchronized, timely, integrated, and cost-effective capability. System integration management, using enterprise architecture, requires a unified set of architectural standards in order to maintain a synchronized interoperability. The JNO intends to use a capabilities-based architecture management approach to deliver timely, end-to-end, integrated capability to the warfighter (OASDNII, 2005). The DoDAF repository is defined by the Core Architecture Data Model (CADM), which will be described further in Chapter IV and will be used to model the capability needs of the future salvage platform for the replacement of the ARS 50 and T-ATF 166.

## **I. DEPARTMENT OF DEFENSE ARCHITECTURE FRAMEWORK (DoDAF) VERSION 1.5 VIEW DESCRIPTIONS**

The DoDAF organizes components of a systems architecture into corresponding views. This method of system architecture is well suited to organizing large systems with interoperability challenges, and is unique in its use of “operational views” detailing the external customer’s operating domain, in which the developing system will operate (Zachman, 2007). DoDAF is organized into four view sets:

- The AV provides an overarching capture of the scope and context of the entire architecture, without focusing on a distinct view of the architecture. The scope and context of the architecture would define the interconnected settings of the architecture, including the subject area and time frame for the architecture. These settings would include techniques, procedures, and CONOPS.
- The OV provides a description of the operational tasks and activities required to accomplish the mission. It also provides schematic representations of operational nodes and the information flow between them.
- The SV describes systems and interconnections between architectural components to the OV, which support organizations and their operations.
- The TV defines the technical standards that administer the system architecture, on which engineering specifications are based. Its purpose is

to ensure that a system satisfies its operational requirements, including policies and standards that govern the system being architected. TV delineates the technical implementation criteria to which the system or SoS should comply. The DoDAF explains TV as a way to promote efficiency and interoperability (DoDAF, 2004).

Figure 19 displays the architectural view descriptions and their interrelationships, “providing the basis for deriving measures such as interoperability or performance, and for measuring the impact of the values of these metrics on operational mission and task effectiveness” (DoDAF, 2007).

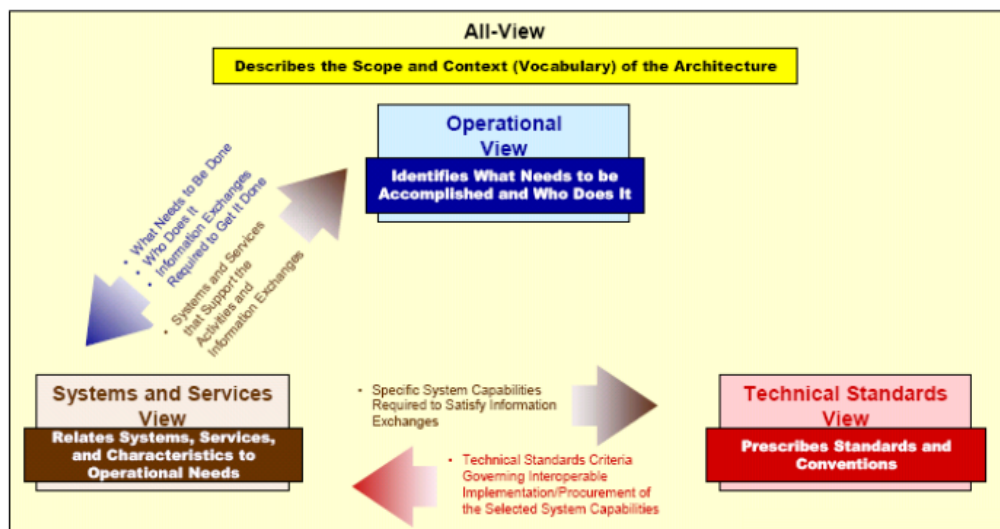


Figure 10. Linkages Among the AVs (From: DoDAF, 2007)

Multiple architectural “views” are created to ensure that stakeholders’ concerns are addressed. The architecture is defined through this series of views, each depicting the architecture with respect to each stakeholder’s perspective, such that it is clear that their needs are addressed. All views are derived from a single system, or SoS, architecture, with each view being derived from a common set of architectural relationships. Architecture exists for the purpose of achieving a well-defined system in both operational and physical domains, such that the eventual system developed from the architecture can be used to meet desired operational capabilities.

## **J. NAVAL ARCHITECTURE ELEMENTS REFERENCE GUIDE**

Architecture implementation is best organized around standard semantics and reference terminology (Ring, 2001). “Every architecture should be constructed from common terms, forming the elemental building blocks of the architecture, standardizing architectural elements” (Naval Architecture Elements Reference Guide, December 2007).

“Architecture elements represent the critical taxonomies, requiring concurrence and standardization for an integrated architecture as described by the DoDAF” (Siel, 2007). They contain the diction for the architectural views and are used to ensure a consistent integration of systems within an SoS architecture. “The data contained in the Navy Architecture Element Reference Guide (NAERG) shall be used for overall architecture framework development, programmatic research, development, and acquisition activities, and related integration and interoperability and capability assessments” (Siel, 2007).

The Supervisor of Salvage (SUPSALV) SoS enterprise will be described in terms of the NAERG elements, in order to explicitly define the architecture. The SUPSALV NAERG elements are organized into the following lists:

- Common System Function List (CSFL)
- Common Operational Activities List (COAL)
- Common Information Element List (CIEL)
- Common Operational Nodes List (CONL)
- Common Systems Nodes List (CSNL)
- Common Systems List (CSL)

## **K. CONCLUSION**

This chapter summarizes many aspects related to the development of a capabilities-driven MBSE process that directly addresses the development of the architecture as the fundamental basis of the systems definition. The process of identifying capability needs, analyzing system functions, and allocation to system physical components cannot currently be satisfactorily completed given existing architecture framework products alone. Chapter II describes the background for the

towing and salvage capability need, Chapter III describes the development of a design reference mission (DRM) for use in mapping mission activities to system functions, chapter IV describes the model-based method for creating the towing and salvage architecture, Chapter V discusses architecture results and chapter VI summarizes conclusions and recommendations.



THIS PAGE INTENTIONALLY LEFT BLANK

## **II. UNITED STATES NAVY SALVAGE COMMUNITY**

### **A. INTRODUCTION**

The Salvage Facilities Act (10 U.S.C. 7361-764) authorizes the Secretary of the Navy to have a salvage program. It allows for the maintenance of a national salvage capability for use in peacetime, war, or national emergency (OPNAVINST 4740.2G, 2007). Salvage forces have unique tasks, which require specialized equipment and highly trained personnel. The “triad” of U.S. Navy salvage forces integrates the Mobile Diving and Salvage Unit (MDSU), Military Sealift Command (MSC), and the Supervisor of Salvage and Diving (SUPALV, NAVSEA 00C), and serves as the core for removing hazards of navigation (in foreign and domestic coastal waters), repair and towing damaged vessels, recovery of sensitive items (such as aircraft black boxes), and recovery of other high-value objects from the ocean depths.

In 1999, Navy salvage assets were involved in a number of high-profile salvage events, such as the salvage of Swiss Air flight 111, the John F. Kennedy, Jr. search-and-recovery operation, and the salvage of a crashed-by-suicide Air Egypt flight. In that year, the only outsourced salvage event was the salvage of an SH-60 in the Arabian Gulf by the Fraser Company. Navy salvage ships were also busy in 2000, with the Air Alaska tragedy. These are a few examples of the tasks completed by these organic forces within the Department of the Navy.

Although each functional element of the salvage triad works jointly for both salvage and towing; each has a separate organizational structure. SUPSALV is an agency (Code 00C) of Naval Sea Systems Command (NAVSEA), which is not in the operational chain of command. For salvage operations directed by the Chief of Naval Operations, SUPSALV is tasked as operational control. Furthermore, SUPSALV is the technical authority for all U.S. Navy diving operations and authorizes any equipment used. When personnel or equipment assets are not available, SUPSALV maintains and exercises all diving and salvage contracts. For deep ocean recovery and emergent ship salvage material, SUPSALV maintains and exercises government-owned, contractor-operated

(GO-CO) equipment and capabilities to provide recovery of objects to a depth of at least 20,000 feet, ship salvage, pollution control, and underwater ship husbandry.

MDSU One and MDSU Two are components of the Naval Expeditionary Combat Command. Their mission is to provide a combat-ready, deployable detachment to conduct harbor clearance, salvage, underwater search and recovery, and underwater emergency repairs. They are equipped with diving and salvage equipment that is air-mobile and scalable to mission objectives. The detachment can be as small as five divers for small operations such as side-scan sonar search missions to larger groups for larger salvage operations. MDSU units work with NAVSEA as separate Operational Activities and as a resource for shallow-water salvage missions.

Currently, the ocean-towing ships are manned with operating crews of civil service mariners (CivMars). In the civilian crewing construct, Navy salvors are embarked as needed to perform the various diving or salvage operations. The salvage ships are currently being converted to civilian manning. For the foreseeable future, the Navy plans to maintain four salvage ships and four ocean-towing ships, all manned by CivMars. CivMars differ from commercial civilian mariners in one key aspect: they can be reliably controlled and are dependable under combat conditions. This distinction is recognized within the MSC (Sperling & Keenan, 2006).

The collaboration with the MSC enables the Navy to provide salvage and towing capabilities. The MSC's mission is to provide combat logistics to sustain United States forces worldwide during peacetime and in war, for as long as operational requirements dictate. Administratively, MSC is a Navy Echelon III command under United States Fleet Forces (USFF), providing more than 40 government-owned and government-operated (GO-GO) ships. Operationally, MSC is the Navy Component Commander to the United States Transportation Command (USTRANSCOM) and supports mission objectives through Sealift Logistics Commanders (SEALOGS). An Echelon IV command—Military Sealift Fleet Support Command (MSFSC)—was formed in October 2006 to man, train, equip, and maintain GO-GO ships. The ARS and T-ATF ships are part of the Type Command (TYCOM) under the MSFSC and are manned by

CivMars. Performing TYCOM Commander duties makes MSFSC the only subordinate command under MSC with global responsibilities (COMSCINST 3191.9B, 2007).

## **B. SEA 00C**

The Office of the Director of Ocean Engineering, Supervisor of Salvage and Diving (SUPSALV), or 00C as it is known in the Fleet, is part of the Naval Sea Systems Command. SUPSALV is located in the Washington Navy Yard in Washington, DC. SUPSALV is responsible for all aspects of ocean engineering, including salvage, in-water ship repair, contracting, towing, diving safety, and equipment maintenance and procurement (SUPSALV, 2008).

The 00C1 Business Management branch is composed of a Logistics branch, a Procurement branch, and a Finances branch. The Logistics branch is responsible for the management and support of logistics, technical manuals, data management, and 00C-specific inventory control. Its responsibilities include:

- managing the logistics requirements and resources at minimal costs;
- managing the preparation and printing of equipment and procedures manuals;
- creating data packages that support contracts; and
- management of the following inventories: Archives, Controlled Records, and Library.

The 00C1 Procurement branch is responsible for managing the contracts that support all salvage, Underwater Ships Husbandry (UWSH), pollution response, and undersea operations. Current SEA 00C contracts include (SUPSALV, 2008):

- The Emergency Ship Salvage Material (ESSM) Contract.
- The Oil Pollution Abatement Contract.
- The Hull Cleaning Services Contract.
- The Western Pacific Salvage Contract, which includes all salvage tasking in the Western Pacific Region.
- The West Coast Salvage Contract, which includes all salvage tasks from the Western Coast of the United States out to the International Date Line.

- The East Coast Salvage Contract, which includes all salvage tasks on the Eastern Coast of the United States, North and South Atlantic Oceans, and the Mediterranean Sea.
- The Undersea Operations Contract.
- The Diving Services Contract.

The 00C1 Financial branch is responsible for all budgetary and financial management functions for SEA 00C-appropriated funds and all customer funding. Responsibilities include receiving, obligating, tracking, deobligating, and returning unused operational funds (SUPSALV, 2008).

The 00C2 Salvage Operations branch maintains the commercial contracts for salvage, emergency towing, deep ocean search-and-recovery operations, and oil pollution abatement (SUPSALV, 2008), and provides salvage technical assistance to Fleet salvors and other federal agencies. 00C2 owns, maintains, and operates the following programs:

- The ESSM system manages a worldwide network of warehouses, wherein an inventory of salvage and pollution abatement equipment is stored and maintained.
- Deep ocean search and Remote Operating Vehicle (ROV) recovery systems, with depth capabilities up to 20,000 feet (ft). The 00C2 ocean search-and-recovery assets include:
  - Cable Controlled Underwater Vehicle (CURV) III ROV.
  - Deep Drone 7200 ROV.
  - Magnum ROV.
  - MINIROVs.
  - Orion Search System.
  - Shallow Water Intermediate Search System (SWISS).
- Emergency salvage response to operations involving strandings, collisions, fires, and engineering casualties with civilian contractors under direction of Navy salvage specialists (SUPSALV, 2008). The 00C2 salvage assets include:

- ARS 50 Salvage Ships
- T-ATF 166 Towing Ships
- Program of Ship Salvage Engineering (POSSE) provides salvage technical assistance to evaluate structural integrity, stability, and all other engineering aspects of salvage operations, using computerized modeling and computations.

SEA 00C25 Pollution Support is SUPSALV's worldwide pollution response division. The division is made up of several branches including pollution equipment, pollution training, pollution response, pollution research and development, pollution planning and compliance, and pollution logistics support. Pollution logistics support is accomplished through a sophisticated support system that utilizes both the military cargo transport system and the commercial transport system.

SEA 00C3 Diving Program is the Navy's and DoD's diving technical authority. 00C3 Diving provides service for diving equipment, policies, and procedures from basic research through prototype development, acquisition/publication, and life-cycle management. It oversees the acquisition of initial Fleet outfitting and life-cycle management of equipment, technical manuals, instructions, and PMS. Additionally, it provides direct Fleet support for technical issues, which includes diving advisories, diver's feedback form, and support contacts.

SEA 00C4 Certification division is the System Certification Authority (SCA) for the U.S. Navy Diving Program. It provides an objective review of the design, fabrication, testing, and operating and maintenance procedures of all U.S. Navy-owned or -operated manned diving and hyperbaric systems. The Certification division consists of three systems engineers, three certification technicians, an administrative assistant, and the SCA. The Certification division performs a multitude of functions in assessing the safety of system designs and hardware. During the system design phase, these functions include the review of design calculations, hazard analyses, material compatibility, system drawings, and quality assurance processes. During system fabrication and testing, certification personnel review procedures and records to ensure that the system hardware is in compliance with the design requirements. After initial system certification,

certification personnel conduct periodic surveys of previously certified systems to ensure that they are maintained in a safe operating condition. This division is also responsible for publishing certification-related technical manuals and instructions (SUPSALV, 2008).

SEA 00C5 is NAVSEA's Underwater Ships Husbandry division. It develops techniques, procedures, and equipment to perform waterborne ship repairs and often eliminates the need for drydock repairs, which extends the interval between drydockings and minimizes the amount of ship time spent in dry dock. The objectives of the UWSH Program are to reduce maintenance costs, while improving Fleet readiness. The UWSH division uses technical experts as on-site field operators to provide training and expertise to Fleet maintenance activities worldwide (SUPSALV, 2008).

### **C. TOWING AND SALVAGE PLATFORMS**

Towing and salvage assets of the Navy perform a wide variety of services in peacetime and in wartime. Among these are: ocean-towing support to a variety of Fleet operations in forward areas and support for the training of Navy salvors and divers; high visibility recovery of aircraft, spacecraft, stranded ships, and barges; routine recovery of lost aircraft and weapons; and post-tsunami, post-hurricane, and post-flooding port clearance. Navy ocean-towing and salvage ships are designed with these functions in mind. Consequently, they should be high-powered towing ships with massive off-ship firefighting capability, and manned with sufficiently trained and skilled rescue personnel to aid an injured ship (Sperling & Keenan, 2006).

Primary Navy combat salvage functions include minimizing and arresting damage, and safely removing damaged combatants from an engagement so the ships can be repaired and returned to action. Salvage ships can perform as towing platforms, but the primary missions are to perform combat salvage, emergency repair, and firefighting. Many of the attributes that make salvage ships good salvage and towing platforms, also make them good platforms for performing these ocean engineering operations; incorporating everything into multifunctional platforms with increasing complexity and cost. Existing Navy salvage ships, as shown in Figure 10, are designed to accomplish all

missions simultaneously. As such, there are a number of design compromises that decrease the ability to optimally perform the variant combat salvage missions (Sperling & Keenan, 2006).



Figure 11. ARS Safeguard class (From: SUPSALV, 2008)

The main mission for the ARS class is diving and salvage. The diver's life support system is integrated into the ship and is capable of supporting up to six divers through its consoles. It also has a fixed decompression chamber. The system has primary 300 pounds per square inch (psi) medium pressure air and 3000psi high pressure secondary air. At the forward part of the fantail there are diver's davits for lowering and raising a diver's stage. Additionally, a 300psi tunneling manifold is available on the port side of the fantail for tunneling under large objects on the ocean floor (SS500-AM-MMO-010, 2007). A detachment of MDSU sailors augment the crew for deployment and emergent salvage operations. MDSU sailors also supplement the ATF MSFSC crew for missions. The ATF class ship does not have any diver's life support systems integrated; it must be brought onboard by the MDSU detachment. The ARS is 255 ft long and 52 ft wide, has a depth of 28 ft, draws 17 ft, and displaces 3,282 tons. Powered by four high-speed diesel engines—twin shaft with controllable pitch props (two fixed nozzles) for a total of 4,200 shp—it has a bollard pull of 68 tons and maximum speed of 14 kts.



In wartime, there is a relationship between the salvage ships and the ocean-towing ships of the Navy. Often during intensive battle operations, combatants that have been stabilized by a salvage ship can be towed to safety by a towing ship, while the salvage ship reaches out for another wounded combatant or is engaged in other combat salvage operations (Sperling & Keenan, 2006). Both classes of ships can perform ocean-going towing services such as towing ships, barges, and targets for gunnery exercises. The Navy's towing effort is limited to ocean towing, rescue towing, and salvage towing. Ocean towing is defined as point-to-point (from one harbor to another) towing with no refuge en route. This includes the safe towing of defueled nuclear powered ships. Rescue towing is the saving a stricken or inoperable ship at sea and towing to safe harbor. Salvage towing ships, as shown in Figure 12, involve the immediate towing of a vessel after a salvage operation. Combat salvage and towing missions involve service in hostile areas, where vessels are damaged, afire, disabled, or stranded due to enemy fire (TOWMAN, 1998).



Figure 12. T-ATF Powhatan class (From: SUPSALV, 2007)

Ocean towing ships are larger and more powerful than harbor- or coastal-towing craft. The current class of Navy towing ships, the T-ATF, is a derivative design from the resupply boat used in the offshore oil exploration industry. It is 226 ft long and 42 ft wide, has a depth of 18 ft, draws 15 ft, and displaces 2,260 tons. Powered by two medium-speed diesel engines—twin shaft with controllable pitch props (two fixed nozzles) for a total of 7,200 shp—it has a bollard pull of 87.5 tons and maximum speed of 15 kts. Designed as a towing ship, it has a towing winch and an automatic towing machine. It also has space for 20 passengers. When a diving detachment is embarked

with equipment, as when performing forward area salvage operations, the containerized decompression chamber and other diving equipment, positioned on the after deck, blocks the ability to tow (Sperling & Keenan, 2006).

**D. PLATFORM CHARACTERISTICS**

Navy salvage ships are outfitted with sufficient salvage requirements to permit the salvage and towing ships to remove and/or float a stranded Navy ship operating in uncharted waters, close to hostile shores. Table 2 displays the major desirable characteristics of a future towing/salvage ship (labeled MSC PM1) and also shows the characteristics of the current towing and salvage ships of the Navy, as well as the general characteristics of a large commercial ocean rescue ship (Sperling & Keenan, 2006).

Characteristics	TATF	TARS	Comm'l <sup>a</sup>	MSC PM1
Class	ABS Class C ice-strengthening, 1 compartment DC criteria	ABS Class C ice-strengthening, 2 compartment DC criteria	Lloyds+100A1 Tug+LMC	ABS Class A ice-strengthening, 1 compartment DC criteria
Length	226 ft	255 ft	307 ft	270 to 280 ft
Breadth	42 ft	52 ft	51 ft	55 to 60 ft
Depth	20 ft	18 ft	28 ft	18 to 20 ft
Displacement	2,260 tons	3,282 tons	4,647 tons	TBD
Propulsion Power	7,200 shp	4,200 shp	25,500 shp	@ 12,000 shp or more
Bollard Pull	87.5 tons	68 tons	200 tons	@ 140 tons

Table 2. Major desirable characteristics of a future towing/salvage ship  
(From: Sperling & Keenan, 2006)

Much of the capability of a towing or salvage ship is in the equipment and outfit of the ship. Tables 3 and 4 summarize the equipage of the four classes displayed in Table 1 (Sperling & Keenan, 2006).

Features	TATF	TARS	John Ross	MSC PM1
Pumping	W/O ESSM load 2,500 gpm	14,000gpm	14,000 gpm	TBD
Electric Power (Overboard)	1,200 kw, 440 VAC	750 kw, 450 VAC	1,500 kw 440 VAC	TBD
Compressed Air	6 flask HP air bank	2- 200 cfm compressors, + 1 portable 125 cfm compres- sor	2- 570 cfm compressors +2 portable 450 cfm com- pressors	TBD
Off-ship fire- fighting	3 monitors, 3,000 gpm, 3,435 gal foam tank	4 monitors, 4,000 gpm, 3,600 gal foam tank	4 monitors, 2,600 gpm, 10,500 gal foam tank	Better than TATF-TARS
Boom/Crane	10 t SWL crane	40 t SWL der- rick	30 t SWL der- rick	A-Frame aft 50 t crane 10 t crane fwd
Ground Tackle	3 anchors asso- ciated gear	8 anchors, associated gear (6 complete legs of beach gear)	6 anchors, associated gear	capable of 4- point moor
Repair shop	Very small workshop	Large machine shop	Large machine shop	Large machine shop module

Table 3. Equipage of the four classes displayed in Table 1  
(From: Sperling & Keenan, 2006)

Features	TATF	TARS	John Ross	MSC PM1
Towing Arrangement	Towing winch (1 wire rope drum and trac- tion machine, 400 fathoms 2.25 in. wire) automatic towing machine	Towing machine (2 wire rope drums and traction machine, 500 fathoms 2.25 in. wire)	2 friction winches, each with associated spooling winch, storing 1,000 fathoms of 2.8 in and 2,2 in. wire	Latest design commercial towing arrangement
Propulsion	2 MSD <sup>a</sup> , 2 reduc gears, twin shafts, CPP, 2 fixed nozzles, twin rudders, 300 bhp bow truster	4 HSD <sup>b</sup> , 2 reduc gears, twin shafts, CPP, 2 fixed nozzles, twin rudders, 500 bhp bow truster	2 MSD, 1 reduc gear CPP fixed nozzle, twin rudders, 800 bhp bow truster	MSD, reduc- tion gear and CPP system
<p>a. MSD = medium speed diesel, b. HSD = high speed diesel</p>				

Table 4. Equipage of the four classes displayed in Table 2  
(From: Sperling & Keenan, 2006).

## **E. DECOMPRESSION**

All types of ship, weapon, and aircraft salvage work require diving personnel in sufficient numbers for extensive underwater operations. They search for and locate underwater objects and obstacles, survey underwater damage, attach lifting devices, cut sunken ship hull structures, and perform many other underwater tasks. Such work often must be done at a variety of depths, necessitating both scuba diving and hard-hat diving skills. Salvage ships are often the platform of choice for deep ocean search and recovery (300 to 20,000 ft of sea water) with SUPSALV search and recovery assets (Sperling & Keenan, 2006).

Supporting a large number of divers for a long period of time necessitates that the salvage ship also have appropriate multiple diver decompression capability. The Navy uses a Standard Navy Double Lock system that permits medical personnel to lock in and lock out to treat divers being decompressed. The remainder of the Double Lock system beyond the chamber should be a plug-in from the current Fly Away Diving System (FADS) technology. In recent years, hyperbaric evacuation (decompression lifeboats) has been rigorously enforced by the civilian ship classification societies, and should be considered in any future diving support ship used by the Navy (Sperling & Keenan, 2006).

The modern deep-sea dive teams, such as MDSU are air-mobile, refer to their teams as Air Detachments. To facilitate rapid deployment and ease of use, prepackaged surface-support systems were developed and containerized. These modular systems, displayed in Figure 13 are referred to as “Fly-Aways” (Lonsdale, 2007).

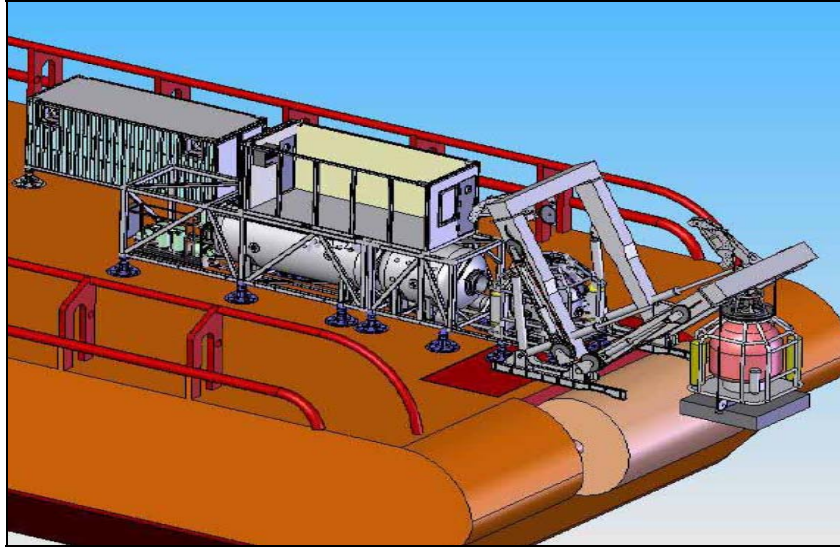


Figure 13. The Saturation Fly Away Dive System (SAT FADS)  
(From: Whaley, 2008)

The SAT FADS are capable of conducting combat salvage and recovery operations, from crisis response to emergent casualties, around the world's littorals to at least 600 ft. They are capable of responding rapidly to missions that support national security requirements including object recovery and internal wreck penetration or to support rescue capabilities. "To meet these requirements the system must be: air & road transportable, fully operational to a minimum depth of at least 600 feet salt water, operate from a vessel or craft of opportunity" (Whaley, 2008).

#### **F. DYNAMIC POSITIONING**

Traditionally, the Navy uses a four-point mooring system to position the salvage ship when operating divers. Dynamic positioning systems are classified by the American Bureau of Shipping by the extent of redundancy built into the system. Class-1 has no redundancy, and is not used with divers. Class-2 can continue to hold position with a single fault, excluding loss of a compartment. That is, it has two independent computer systems and this positioning system can be used with divers, within the restrictions established by the Supervisor of Salvage. Class-3 has the most redundancy and can hold position following any single fault including loss of a compartment due to fire or flooding, having at least two independent computer systems with a separate backup

system. The DP-3 positioning system can also be used with divers. A DP-3 ship that loses an engine room will not deviate from its positioning objective (Sperling & Keenan, 2006).

## **G. FIREFIGHTING**

Current Navy off-ship firefighting can be accomplished by both classes, though firefighting capabilities remain insufficient. The ARS, the Navy's most capable firefighting ship, can apply foam at a rate of 1,250 gallons per minute (gpm) for 15 minutes. In comparison, *Smit-Rangoon* pumped foam at 3,300 gpm for an hour and a half, while assisting USS *Stark* in 1987. Using the data from the fire that occurred aboard USS *Stark*, the Navy's best firefighting assets did not carry a sufficient quantity of foam and did not have sufficient pumping rates to extinguish fires on small ships such as the one on the *Stark*. Additionally, at a minimum, such a ship should carry 210 short tons of Aqueous Film-Forming Foam (AFFF) at 3 percent concentrate and be able to deliver foam at a rate of 4,000 gpm for at least an hour (Sperling & Keenan, 2006).

## **H. BOLLARD LIFT**

Often it is necessary in wartime to open or clear blocked waterways or harbors to improve logistic flows to engaged forces ashore. Because of this combat requirement, Navy salvage ships were often designed with a static lift wherein, by ballasting down and then clearing the ballast tanks, they can lift large objects from a harbor floor and move them out of the way. For heavy lift of sunken material, the ARS can exert 300 tons of lifting force via stern and bow rollers (SS500-AM-MMO-010, 2007). The ARS is equipped with 10-ton capacity crane and has a maximum lift of 100 tons over stern rollers. The aft boom on the ARS forms a compensating system with its vang and topping tackle, which allows for simultaneous control of slewing and topping ensuring load stability up to 40 tons. The forward boom on the ARS also has this capability up to 7.5 tons when rigged in the aft position (SS500-AM-MMO-010, 2007).

## I. BOLLARD PULL

The towing force exerted at zero speed and full power is called bollard pull. This is a measure of the strength of a ship to tow other ships. Typically, bollard pull is measured in tons. The bollard pull of existing Navy salvage ships was compared to commercial salvage ships, and were found to have much less bollard pull and to not handle the towing of larger ships in a seaway. Figure 14, taken from the earlier T-ATF study, was developed using the *Navy Towing Manual*. It shows the force needed to pull four Navy ships of different sizes at various speeds in sea state 3. The towing force increases approximately as the square of the speed.

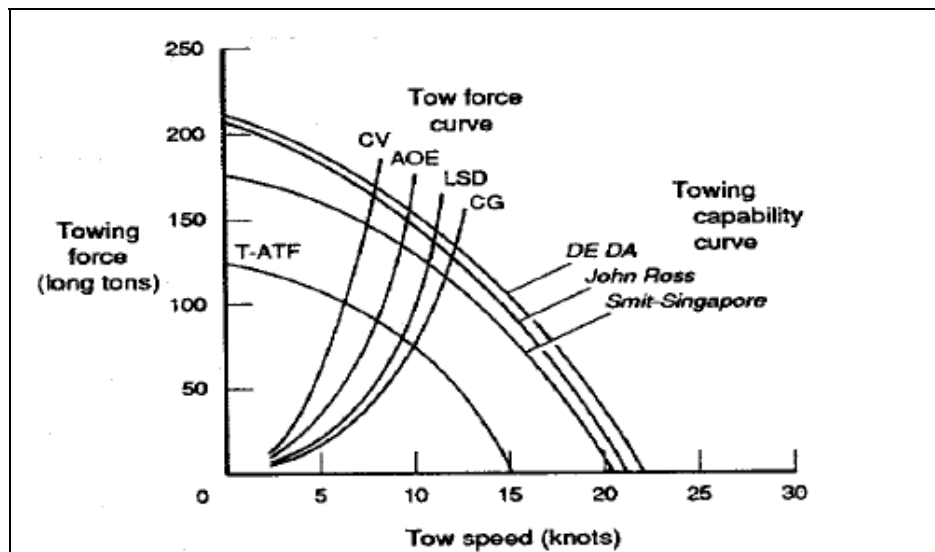


Figure 14. Force needed to pull Navy ships (From: TOWMAN, 1998)

As Figure 14 shows, the current towing ship (T-ATF), when rated at 120 tons bollard pull, is able to tow a surface combatant at speeds up to 10 knots, whereas a salvage ship (ARS) would be limited to about 7 knots. Comparatively, the larger commercial towing ships could perform the same task in about half the time, at about 13 knots. For towing larger ships, the tow capability of the current salvage ship is marginal at best. The replacement for both the towing ship and the salvage ship should have improved towing capabilities. Figure 14 also plots the towing capabilities of some typical commercial rescue ships: *Smit-Singapore* of The Netherlands, *John Ross* of South Africa, and *DeDa* of China (Sperling & Keenan, 2006).

**J. CENTER FOR NAVAL ANALYSIS (CNA) STUDY**

CNA has produced three salvage ship-related studies over the past few years. Five years ago, they reported a series of alternatives for decision makers, making the case for various levels of salvage and ocean-towing ships in wartime. That work included a detailed examination of anticipated damage to combatants in battle and estimates of damage control and at-sea salvage efforts necessary to save the damaged ships from falling into the hands of a determined enemy. Based on that work, the Navy chose to keep its active force of four Navy-manned salvage ships and five CivMar-manned ocean towing ships. The study also suggested that forward positioning would permit such a small force of slow ships to be responsive to various likely wartime scenarios, worldwide. Since 1998, NAVSEA 00C has contracted in peacetime 123 ocean-towing, salvage, and search-and-recovery operations to commercial ship operators. This is almost 19 events per year.

During the period 1999 to 2005, the Navy had four salvage ships and four to five towing ships in service, supporting both fleets. One towing ship, T-ATF-167, was inactivated in September 1999, and another was sent to the inactive ship facility in 2005. In the earlier period, the civilian-manned towing ships were at sea significantly more than the salvage ships. In the data for 2005, they seem to be spending an equal amount of their time at sea. However, the ARS assigned to Hurricane Katrina harbor clearance may have skewed the data for 2005. Figure 15 displays a proportional comparison of the time each class has been underway (Sperling & Keenan, 2006).

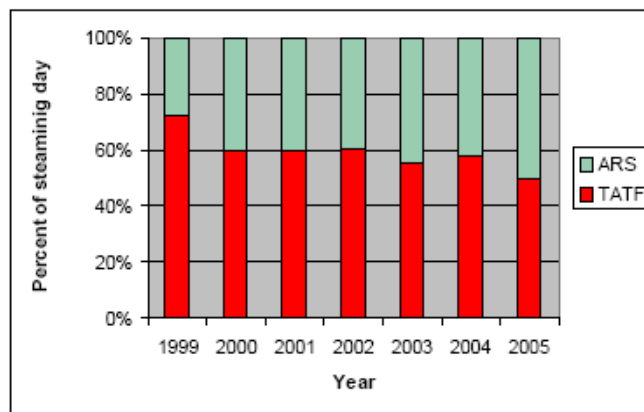


Figure 15. ARS vs. T-ATF usage (From: Sperling & Keenan, 2006).



The Navy now has four ARS salvage class ships and the remaining four ocean-towing ships of the T-ATF-166 class entered service between the end of May 1980 and the end of July 1981. They will collectively reach 35 years of service life in 2015. The Navy has a draft plan to replace all four towing ships between 2014 and 2016. The four salvage ships of the ARS-50 class were commissioned and entered service between mid-August 1985 and mid-November 1986. They will reach 35 years of service life in 2021. The shipbuilding plan does not extend far enough to specifically identify a cost for replacing the salvage ships when they are no longer serviceable.

## **K. FUTURE PLATFORM REQUIREMENTS**

In 1989, CNA developed a set of tentative operational requirements for the Ships Characteristics Improvement Board of the Office of Chief of Naval Operations for a new and future class of salvage and towing ship (Light, 2007). The force-level requirements have been derived from the combatant ship force-sizing scenarios and, from them, calculated likely cases of possible combatant ship casualties, with the assumption that ships hit are savable. Therefore, they offer potential at-sea salvage cases to which the salvage ships and ocean-towing ships can be applied. The work investigated the current Navy salvage assets (such as the T-ATS-1, T-ATF-166, and ARS-50 classes) and showed that a faster salvage ship, capable of applying more foam onto a ship on fire for longer periods, would be desirable.

With all salvage and towing ships manned by CivMars and now available for up to 270 days a year, four ARSs are sufficient to meet the peacetime employment prediction. Unfortunately, to be responsive to likely wartime needs, the ARSs need to be forward where there is little peacetime towing activity and very little high-visibility peacetime salvage work. Consequently, as many as four ocean-towing assets (T-ATFs) should be retained to permit the force to perform both the peacetime and the wartime jobs.

The USFF analysis suggested the combined warfighting and peacetime requirements are nine vessels to accomplish both towing and salvage tasks; an acceptable risk would be eight. CNA analysis suggests seven ships, augmenting with contracted commercial tows as needed. Currently, the warfighting requirement dominates peacetime demand (Light, 2007).

To accommodate a ship-building plan for eight ships of a single-hull type, the assumption is made to establish a timeline to begin lead ship construction in FY16. The notion is to replace the legacy ships (both ARS and ATF) near their end of service life (ESL) of 40 years. Preconstruction activities should begin in FY10; starting with establishing an IPT, acquisition strategy, and formalizing ship requirements (Light, 2007). In following years, a notional timeline is as follows:

FY12 Perform concept and preliminary design and program documentation.

FY13 Develop notional design, cost estimates, and contract documentation.

FY14 Award competitive Phase I design contracts and oversee design phase.

FY15 Complete design phase; execute source selection for Detail Design and Construction phase.

FY16 Award contract for Phase II Detail Design and Construction.

## **L. SUMMARY**

The salvage platforms of the Navy have become a vital part of a wide range of military operations, as highlighted in this chapter. The life cycle of the current towing and salvage ships are soon coming to an end, with a need for a future possible single-hull salvage platform within the next 10 years. At this time, an SoS architecture has not yet been developed to attain the proper systems requirements, based on the community's needs. The architecture elements data for the towing and salvage community has not yet been entered into the current NAERG metrics. All other system functions, activities, elements, and nodes that have not yet been recorded, have been entered into the towing and salvage architecture for the purpose of this thesis.

United States Navy salvors depend on the systems needed to successfully complete their missions, maintain equipment functionality, and operate in extreme environments. To enable timely and reliable mission completion, individual systems

must work efficiently together as an SoS. Desired requirements have been proposed by SEA 00C based on current ship capabilities, and require a capability-based requirements generation process, based on the current and future mission objectives. This proposed requirements-based architecture has been defined as being a single-hulled ship that meets mission needs and stakeholders' concerns, which synthesizes a design for acquisition of this new ship class. The alternative is to utilize the commercial market, analyzing the capability-based architecture defined in this thesis. An explanation of the architecting process, and its application with an architecting tool, is described in Chapter III.

### **III. MISSION ANALYSIS**

Since the beginning of warfare, successful military leaders have recognized the importance of knowing the enemy, knowing the terrain, and knowing themselves (Skolnick & Wilkins, 2000).

#### **A. BACKGROUND**

The complexity associated with ocean salvage operations, particularly deep water operations, makes this knowledge of enemy terrain and themselves even more crucial. The DoD must ensure that the towing and salvage community is developing systems to accomplish their assigned missions in a timely manner and positioning them accordingly. In order to provide the salvage platform baseline for trade studies to establish a CONOPS for salvage SoS design, the DRM concept will be used.

A DRM defines the operational activities necessary for mission completion. “Also, the DRM establishes the baseline for subsequent systems engineering activities - particularly generation of requirements, refining problem definition, development of concepts, and analysis of alternatives, and testing and evaluation. A well developed DRM will facilitate generation of requirements and subsequent system design” (Skolnick & Wilkins, 2000).

“For the government led development process, the DRM feeds the development and certification of a system functional baseline and provides support through the entire life of the program. Thus the DRM must support the program throughout the systems engineering process” (Skolnick & Wilkins, 2000). To ensure that the final iteration of the DRM is the best solution for capabilities-driven requirements generation, it is important to receive feedback from all actors associated with the system and then to refine the DRM based on that feedback.

Composing a DRM begins with understanding the operational concept of the system and then placing that system into a simulated environment in which it can perform. Once in a mission-executable environment, the capabilities or operational activities necessary to complete that mission will become apparent. Designing a reference mission begins with understanding the environment within the mission

analysis, which consists of defining the target and refining the mission scenarios. A scenario includes the goal, the deployment of the systems, the physical environment in which the mission takes place or is executed, and the change the environment will undergo as the scenario progresses.

The evolving DoD systems acquisition process heightens the need for the operating baseline provided by the DRM. The traditional acquisition process, i.e., one in which a government team develops detailed system specifications that are then provided to industry to guide system development, has been modified to involve industry earlier in the process (Skolnick & Wilkins, 2000).

For effective SE, accurate problem solving cannot occur without proper problem definition. A preconceived problem solution or requirements-first SE results in biased design. The generation of a DRM for problem definition will lead to an accurate problem solution to support the range of stakeholders' needs.

#### **B. DESIGN REFERENCE MISSION (DRM): PROJECTED OPERATIONAL ENVIRONMENT (POE)**

The POE is the environment in which the ship is expected to operate. It provides the necessary details to describe the mission areas, environment, and types of locations to determine the operational capabilities for which the ship class will be designed. The POE provides information for establishing tasks that produce a measurable workload used to compute manpower requirements. The T-ARS(X) will perform the capabilities of both towing and salvage platforms, thus it will need the same operational requirements listed below:

TATF-166 POE (OPNAV Instruction 3501.177, 1988)

- At sea in wartime.
- To perform towing at sea operations.
- To perform rescue towing and limited salvage at sea service.
- To perform debeaching operations.
- To extinguish fires on ships in distress.
- Act as support ship for the deployment and recovery of portable oil spill recovery equipment and portable, self-sustaining, deep diving equipment.



## 2. Maritime Conditions

### *Sea State*

Gulf of Mexico <2

### Water Temperature Isothermal

Day 83 F

Night 81 F

### *Bathymetry*

Depth 4m – 12m

Bottom Types Sand, Mud

### *Currents*

Gulf of Mexico near Mississippi river outlet 3 kts

## 3. Climatic

The climate is described as hot, humid, and rainy. Thunderstorms occur daily from May to October. Tornadoes and waterspouts occur throughout the summer months. Hurricanes occur from June through September.

## 4. Meteorological Date: 04 July 2008

### **Temperature**

Average Maximum 88-91 F

Average Minimum 69-71 F

Extremes 60-98 F

### **Winds**

Mean Surface 12 mph

December - April from southeast

June - October from northwest

### **Relative Humidity**

Mean 89%

Diurnal Range 65%-98%

### **Precipitation**

Average Annual Rainfall 61.88 inches

**C. DESIGN REFERENCE MISSION (DRM): POTENTIAL SALVAGE TARGETS**

FLOODED/SUNKEN/DAMAGED/LOST VESSEL:

1. Fishing vessels in transit lane requiring repair and tow.
2. Damaged fuel-oil system, pollution response.
3. Lost craft in need of medical assistance.

**D. DESIGN REFERENCE MISSION (DRM): CHARACTERISTICS OF SUNKEN VESSEL IN TRANSIT LANE**

The specific target is defined by the problem as a sunken fishing vessel impeding the transit lane at the mouth of the Mississippi River outlet. This section will describe the fishing vessel, displayed in Figure 17, in general and those specifically registered to operate near the Mississippi Sound.



Figure 17. Large fishing vessel aground to simulate mission objective  
(From: Wikipedia, 2008)

**1. Size**

There are many fishing vessels of various sizes that pass through the mouth of the Mississippi River. For this model, a large vessel, approximately 130 ft long and 150 tons, will be used.



## 2. Position

The position of the sunken vessel will be at the mouth of the Mississippi River near Vinice, Louisiana, as indicated in Figure 18.

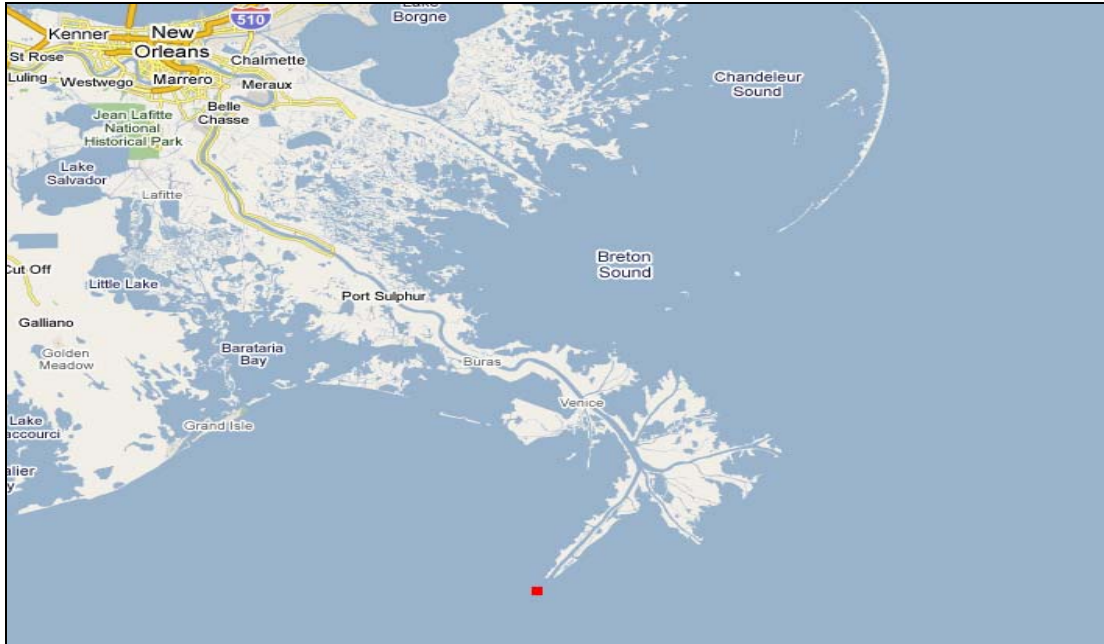


Figure 18. Location of fishing vessel and mission environment  
(From: Google maps, 2008)

## 3. Depth

The depth at the target location is 12m at high tide at the stern of the vessel and 4m at the bow of the vessel.

## 4. Damage

The vessel has a 2m diameter hole in the starboard quarter. Once patched, the structure will be water tight. The propulsion system has been flooded and is inoperable. Once floated, the vessel will be dead in the water and not under command.

## **E. DESIGN REFERENCE MISSION (DRM): OPERATIONAL SITUATIONS (OPSIT)**

### **1. Discussion**

In order to develop a comprehensive and efficient system, the system developer/engineer must go through the planning process to determine “how” the mission will be accomplished. The product of this mission analysis is a plan that details tasks to be assigned to the SoS in order to complete the mission. A mission consists of multiple operations, and its execution typically involves multiple systems simultaneously conducting a variety of assigned tasks. These tasks are integrated and synchronized in order to anticipate the operational requirements necessary to achieve the mission.

OPSITs can depict task lists in required for the necessary operational activities. Operations templates provide a graphical description of the activities and tasks involved in mission planning, along with their interrelationships. There are various characteristics of activities, ranging from a one-time occurrence to a continuous event. An example of an activity that may occur only once over the defined mission time period, is the platform deployment to the mission theater. Other tasks may be continuous, like positioning the salvage vessel in deep water. Each of these types of tasks can be represented and distinguished within a design reference mission. OPSITs can depict tasks required to perform the mission commander’s CONOPS. The commander determines the tasks that are essential to mission success and identifies these as Mission Essential Tasks.

“OPSITs templates are discrete multi-engagement event diagrams with specified operational characteristics. The use of discrete OPSITs provides a set of fixed ‘test points’ that collectively yield a representative sampling of the problem space” (Skolnick & Wilkins, 2000). These test points are displayed in Figure 19, with an example of a DRM. “Users are encouraged to conduct a parametric exploration of the problem space to aid concept definition, with the understanding that OPSITs are specifically developed to stress selected system design attributes and support functional and performance trade-off analysis” (Skolnick & Wilkins, 2000). Each OPSIT should feature one or more stressing operational characteristics that will support a high-stress condition to a functional trade space.

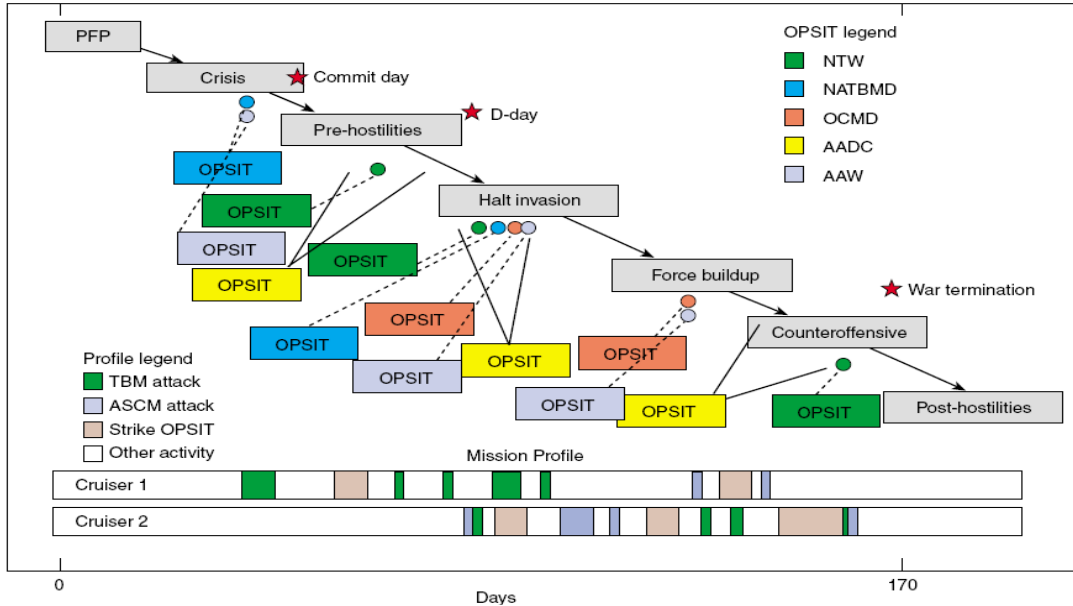


Figure 19. DRM OPSIT construct example (From: Skolnick & Wilkins, 2000).

OPSITs can be thought of as specific instances of a DRM where the variables can change, creating unique OPSITs for that mission time. OPSITs can be compared to DoD testing and evaluation (T&E) in that the system is stressed within a real-time scenario, verifying that the system’s capabilities or operational activities are sufficient to perform the mission effectively. However, OPSITs differ from T&E in that they can be as simple as formalized Table Top Exercise. The information and feedback from Subject Matter Experts (SMEs) is imperative to quality OPSIT development. OPSITs should be validated by the SMEs, creating a balance between the average and extreme situations (Skolnick & Wilkins, 2000).

## 2. OPSIT Generation

For every operational activity assigned to a mission, a set of operational tasks are defined to develop a CONOPS. This process is designed to identify the existing military capabilities required to execute a mission. In addition, assumptions are made about the environment, logistics, deployment, and time required to achieve the mission.

Assumptions are realistic variables meant to provide validity to the scenario, while keeping it manageable. In choosing assumptions, displayed in Table 5, the

developer must determine what type of solution should come from the OPSIT. In this thesis, all events are assumed to occur during the day, but subsequent studies could examine nighttime scenarios.

<b>ASSUMPTIONS</b>	
Date/Time	04 July 2008/1200
Ship Type	Fishing Vessel
Length	40m
Weight	150 tons
Damage	2m diameter hole in starboard quarter
Pollution	Oil sheen
Water Depth	<12m
Visibility	<1m
Sea State	<2
Bottom Type	Mud, sand
Structural Integrity	Intact

Table 5. DRM assumptions

For this work, the four main variables that will change will be Visibility, Pollution Level, Sea State, and Damage. Table 6 displays the OPSIT variables that will change with time and environmental effects. The target characteristics and location can differ from scenario to scenario; however, this mission will stress the most capabilities and timing requirements that a possible future salvage platform may encounter.

<b>Characteristic</b>	<b>Stress Level</b>	<b>Value</b>	<b>Probability</b>
Sea State	L	1	H
	M	2	M
	H	3	L
Visibility	L	>2m	M
	M	>1m, <2m	H
	H	<1m	M
Pollution Level	L	No Pollution	L
	M	Minimal Pollution	H
	H	Major Pollution	M
Damage	L	Single, Repairable	M
	M	Multiple, Repairable	H
	H	Multiple, Unrepairable	L

Table 6. OPSIT variables with respective stress levels

Table 7 represents the extremes for mission preparedness showing the low-, average-, and high-stress OPSIT scenarios, following Skolnick’s advice that OPSITs should feature one or more stressing operational characteristic.

Possible OPSITs	Sea State	Visibility	Pollution	Damage
Low-stress OPSIT	L	L	L	L
Average-stress OPSIT	M	M	M	M
High-stress OPSIT	H	H	H	H

Table 7. Low-, average-, and high-stress OPSIT scenarios

### 3. Mission Success Requirements

The OPSIT will identify the individual activities that need to be accomplished in order to define the success of the mission. The requirements identified for the success of this DRM will be measured in four categories:

- Removing oily waste.
- Lifting the vessel from the bottom.
- Repairing the vessel to stability.
- Towing the vessel away from the mouth of the river.

The mission is divided into these categories based on the specific functions that each individual operational activity is required to perform. Each category must be completed in order to identify the mission as being successful.

### F. MISSION DEFINITION

In order to complete the mission success levels, all T-ARS(X) salvage, towing, heavy lift, diving, and pollution response capabilities or operational activities will be utilized. Each mission included within a DRM scenario can be decomposed into the individual operational activities necessary to complete the tasks that the DRM scenario requires. The DRM is decomposed into the following operational activities:

- Towing.
- Salvage (including Heavy Lift).
- Diving.
- Pollution Response.

Once all operational activities or capabilities have been identified, the components required to achieve the functions necessary to complete the mission will be identified and documented.

THIS PAGE INTENTIONALLY LEFT BLANK

## IV. ARCHITECTING PROCESS

### A. INTRODUCTION

It is possible to do either an SE process without producing a systems architecture, or creating an architecture without subjecting it directly to an SE process. However, the quality of the outcome from the two processes done independently will be substantially lower than if the two processes are done in conjunction. “There is a great need to describe a process to ensure that the architecture, the arrangement of elements and their relationships, is well-defined and addresses the needs of the stakeholders”(DoDAF, 2004).

The purpose of this chapter is to describe the steps taken to develop an SoS architecture, from the mission design to the system specification, with the aid of an architecting tool. The development of an architecture using CORE is defined for the future salvage platform SoS and adequately identifies the capability-based requirements in terms of the operational mission objectives. This chapter also illustrates how a U.S. Navy Diving and Salvage system could be architected in the context of an SoS from an identified set of stakeholder needs.

The MBSE integrated methodology is used to select the most efficient SoS architecture. The identification of the salvage platform SoS begins with the mission objectives from the CONOPS of the salvage force, to developing a DRM, and leading to an appropriate architecture supported by modeling and simulation. The framework used in the development of the SoS architecture is modeled in CORE, and will be used as a foundation for future capability-based architectural modeling for the future salvage platform force structure (Huynh & Osmondson, 2007).

Key outcomes described in this chapter are an architecting and architecture generation process (with focus on stakeholder needs), ideally suited to salvage systems complemented by an SE process—from engineering requirements definition to physical architecture integration—for fusing the diverse assets involved in this complex system.



## **B. CORE 5 ARCHITECTURE**

A major challenge in the architecting process is developing an architecture so that the system elements are complete and consistent with one another. An architecting tool is a great asset that is used to verify that the data is consistent and that all element connections remain with their associated counterparts. The amount of data, when complying with architecture standards such as the DoDAF, is too large to manipulate manually. The CADM can aid in this task.

CORE is a unified model that integrates the architectural frameworks with the SoS development process and the element relationship representation of the SoS model. “The CORE product suite is a fully integrated, flexible approach to a collaborative product design specifically developed by systems engineers for systems engineers” (CORE 5 ADG, 2007). CORE delivers a mutual design-centric approach to product development. “CORE provides comprehensive traceability from need definition through requirements and analysis to architecture and test. Built upon a proven approach and a central integrated design repository, CORE includes a comprehensive behavior modeling notation” (CORE 5 ADG, 2007).

Operational models are developed using MBSE principles. The design activities integrate the operational model and the systems model, and consist of requirements analysis, functional analysis, physical architecture synthesis, and verification and validation (CORE ADG, 2007). All steps of the SE process, as described in Chapter I, can be completed using this CORE model-based SE architecture.

“CORE focuses on an architecture synthesis centric approach rather than a view or document centric approach. This provides traceability from capability through requirements and analysis to testing. The CORE software suite was designed by systems engineers to satisfy diverse civilian and military customer (or stakeholder) needs” (Giammarco, 2007). An overview of the MBSE process is displayed in Figure 20, which shows the stages of the architectural development process.

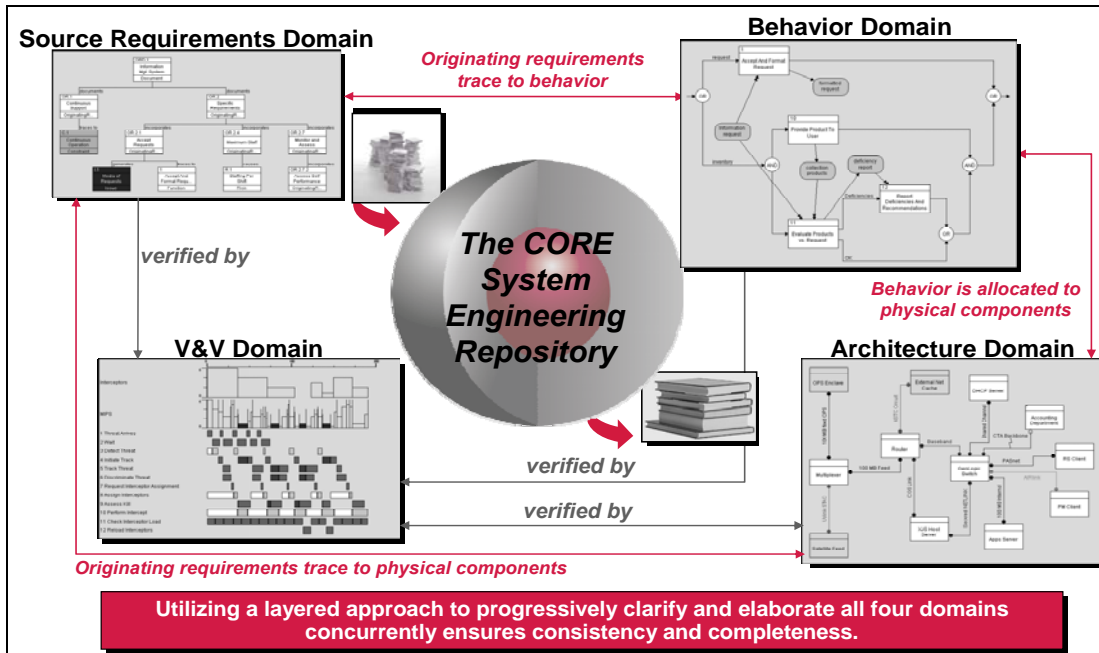


Figure 20. CORE Approach Relationships from the CORE Architecture Definition Guide [DoDAF version 1.5], (From: Vitech, 2007).

CORE is built around a central integrated design repository. It includes a comprehensive behavior modeling notation to understand the dynamics of a design. CORE is a MBSE tool designed to integrate architectural and engineering activities while developing operational and system models. Documentation, such as the DODAF views, are derived from the basis architecture produced (CORE SE Guided Tour Vitech Corporation, August 2007).

As displayed in Figure 20, the architecture elements from the DoDAF version 1.5 schema are integrated into a database of element classes within CORE to enable the systems engineer to define the element relationships and display the system hierarchies.

The architecture is divided into two behavioral domains: operational architecture and system architecture. Each domain is described in detail below. “The Operational Architecture Domain captures originating concepts, capabilities, and supporting operational analysis to exploit, whereas the System Architecture Domain expresses the requirements, functions, and components comprising the physical design” (CORE Architecture Definition Guide [DoDAF version 1.5], Vitech Corporation, August 2007). Displayed in Figure 21, the CORE architecting schema separates the systems and operational domains with relationship lines connecting the individual elements.

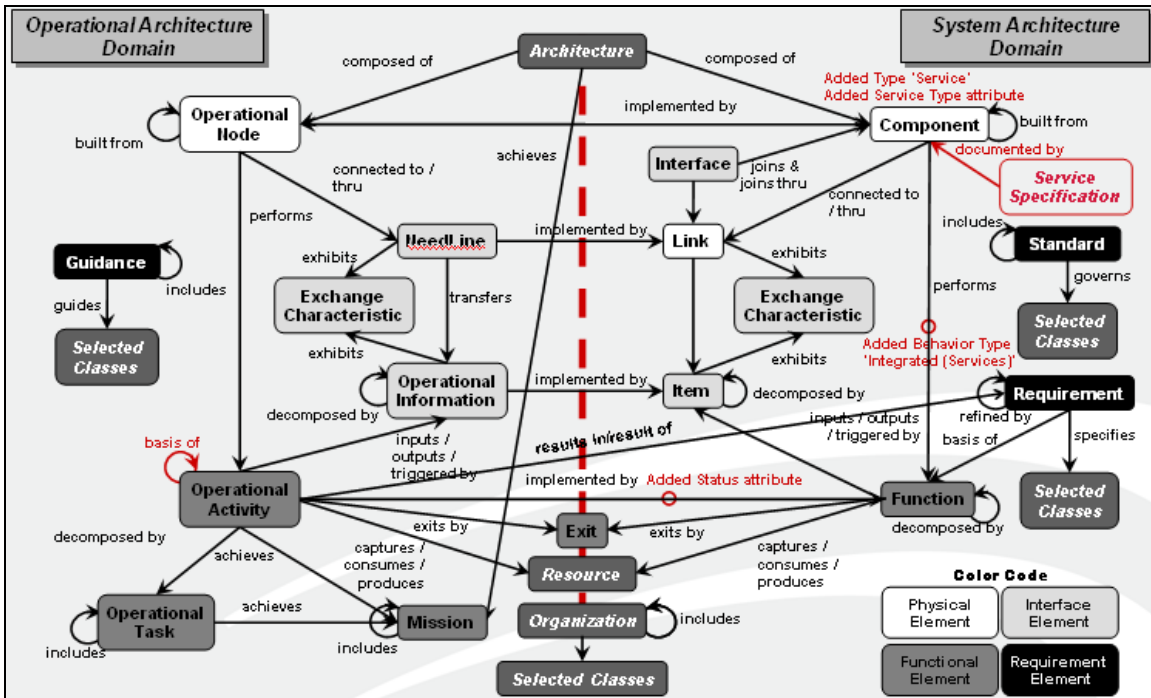


Figure 21. CORE DoDAF Schema (From: Vitech, 2007)

The CORE architectural elements that will be focused on in this thesis are the Architecture, Operational Nodes, Operational Activities, Missions, Functions, and Components. From these elements, the necessary DoDAF architectural views and system specification document can be formulated. This chapter will describe in detail the individual elements, as well as how they relate.

### C. ARCHITECTURES

“Architectures exist for the purpose of achieving a well-defined system in both the operational and system domains, for a specific time frame. The Architecture class is used to identify an architecture and its time frame” (CORE ADG, 2007). Nodes in the systems architecture are defined as components, while nodes in the operational architecture are defined as operational nodes. For the towing and salvage platform model, the architecture was created as “Towing and Salvage,” with the operational and systems architecture elements completed and described in Figure 22.

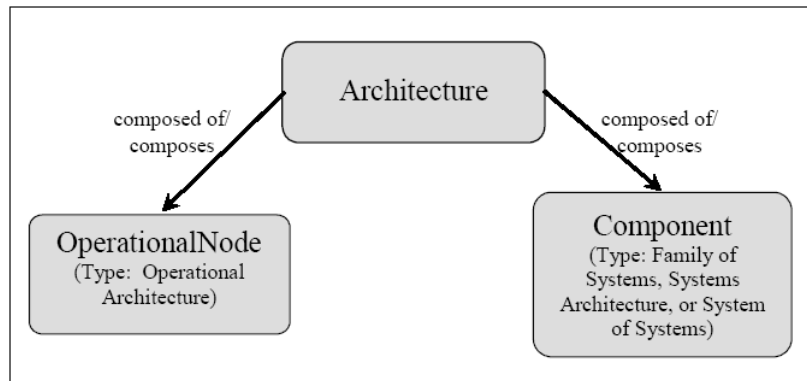


Figure 22. Architecture element decomposition (From: Vitech, 2007)

## 1. Operational Architecture

Given the need to comply with the framework of the operational requirements document, the systems engineer must define the operational behavior in order to accomplish the mission. The operational architecture organizes the architectural elements, which compose the operational behavior of the system. The operational architecture is made up of the operational nodes, operational activities, operational tasks, and missions. Creating an operational architecture begins by first defining the mission, and then by identifying the operational activities needed to accomplish the mission. Once all of the operational activities have been identified, the responsible operational nodes can then be defined.

## 2. Operational Nodes

“Within the Operational architecture domain, the operational node is part of the operational context which also includes the elements that represent the external aspects of the operational domain” (CORE ADG, 2007). An operational node is a representation of an actor role within an organization that produces or consumes information. The operational nodes for the future towing and salvage platform are all of the actors/organizations that interact with and make decisions for the system. They include:

- SEA 00C (SUPSALV) including all departments.
- MDSUs One and Two.
- ESSM.
- MSFSC.

The operational nodes can be decomposed and displayed in CORE as a system diagram, as shown in Figure 23. Further breakdown of the operational nodes would characterize operational activities.

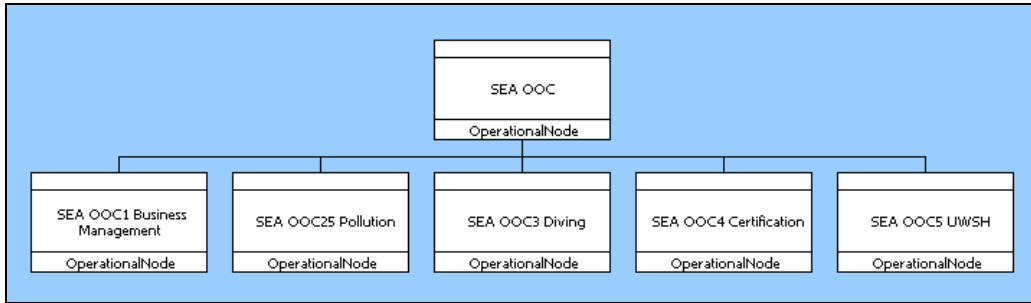


Figure 23. SEA 00C Operational Node decomposition

### 3. Operational Activities

In conjunction with operational architecture synthesis, for each layer of operational nodes, operational activities are decomposed until they can be uniquely assigned to the next level of operational node using the performed by relationship. This not only establishes the organization or role that performs the activity, it allows the systems engineer to assess the impact of operational node failures on both mission and operational activities (CORE ADG, 2007).

Operational activities also called operational scenarios, consist of a sequence of capabilities needed to respond to an external stimulus. Each operational activity is performed by an element within the operational node class displayed in Figure 24. Finalized capabilities (operational activities), are incorporated to become the integrated model for the architecture.

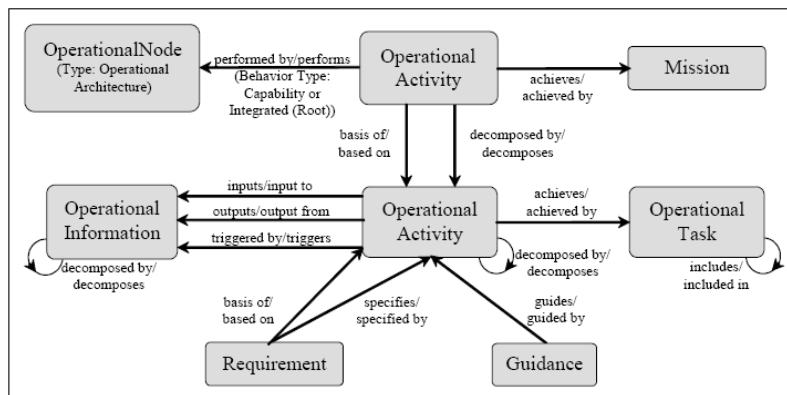


Figure 24. Operational Architecture Diagram with relations (From: Vitech, 2007)

The operational activities are linked to the systems architecture domain through the function element, and are traced from operational nodes and achieve operational tasks and missions, as displayed in Figure 25. “Operational activity traceability from an appropriate mission element is established using the ‘achieves’ relationship. Establishing this relationship enables one to easily assess what capabilities are impacted by a mission change and what missions are impacted by a capability change or failure” (CORE ADG, 2007).

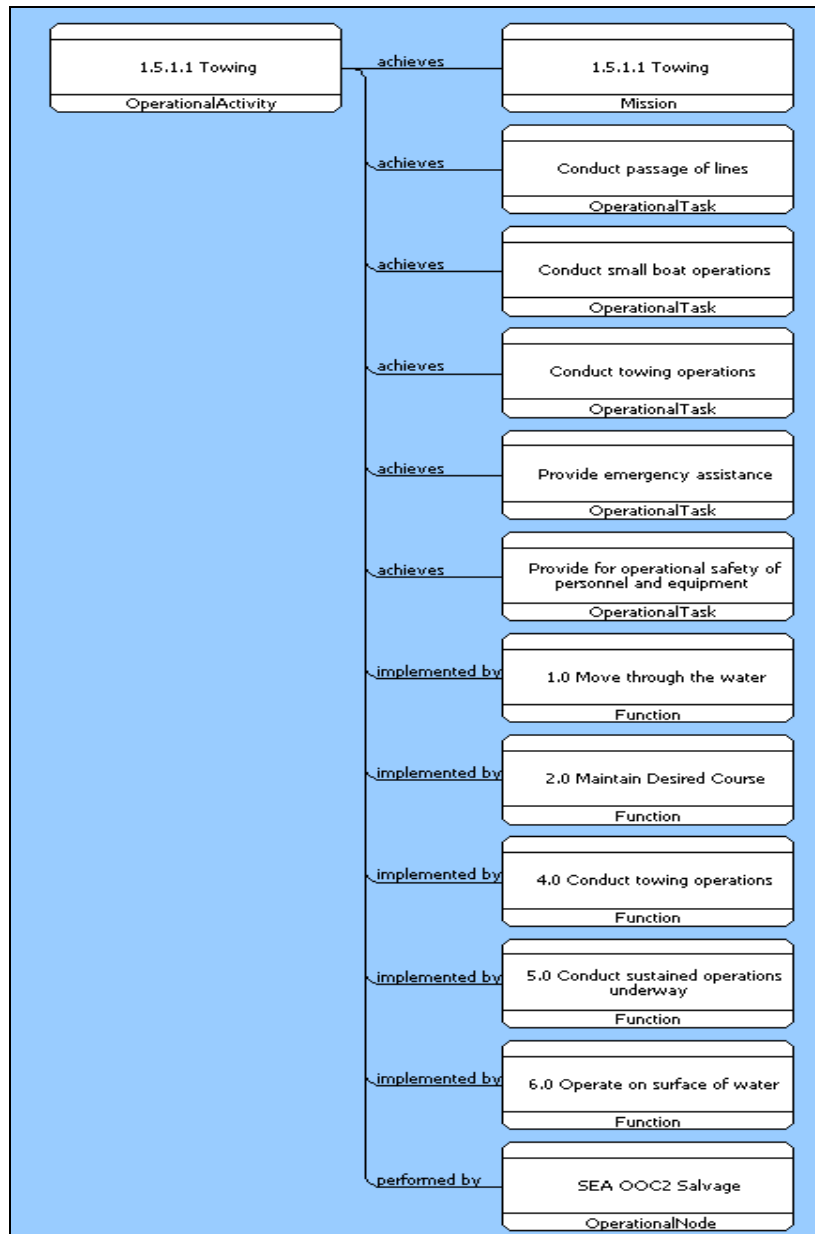


Figure 25. CORE systems view of the operational activity “Towing”

#### **4. Required Operational Capabilities (ROC)**

Required Operational Capabilities (ROC), as constituted by mission commanders, detail the capabilities required of ships in various operational situations outlined in the POE. The level of detail is decomposed to outline specific mission areas and component/operator responsibilities. The ROC provides the necessary details of operational capabilities for which the ship class was designed, based on expected missions. It will establish tasking that produces a measurable workload used to compute manpower requirements.

TATF-166 ROC (High-level) (OPNAV Instruction 3501.177, 1988)

- Anti-air warfare.
- Anti-surface warfare.
- Command, Control and Communications.
- Fleet support operations.
- Intelligence.
- Mobility.
- Noncombat operations.

ARS-50 ROC (High-level) (OPNAV Instruction 3501.136b, 2007)

- Anti-air warfare.
- Anti-surface warfare.
- Command, Control, and Communications.
- Command and Control Warfare.
- Fleet support operations.
- Intelligence.
- Mine warfare.
- Mobility.
- Missions of state.
- Noncombat operations.

The ROC is further decomposed into operational tasks needed to fulfill the operational activity. For example, the operational activity “Mobility” is composed of lower-level activities such as “move through the water” and “conduct sustained

operations underway.” Each of these activities can be further decomposed into individual tasks necessary to achieve the activity “move through the water.”

## 5. Operational Task

The operational task element decomposes a list of mission-derived tasks with associated conditions and standards that a system architect may select to accomplish a simulated mission. The Universal Naval Task List (UNTL) is a combination of the Navy Tactical Task List (NTTL) and the Marine Corps Task List (MCTL), and was utilized to identify the universal tasks that the towing and salvage platform must perform.

The UNTL contains a comprehensive hierarchical listing of the tasks that can be performed by a naval force, describes the variables in the environment that can affect the performance of a given task, and provides measures of performance that can be applied by a commander to set a standard of expected performance (UNTL, 2006).

Along with the UNTL, there are task lists derived from a hierarchy of DoD tasks contained within the Universal Joint Task List UJTL displayed in Figure 26. Depending on the mission level being developed, a certain standard of tasks are required to fulfill that mission-level requirement. If the mission involves joint service cooperation, the tasks would be derived from the UJTL at a higher-level mission perspective.

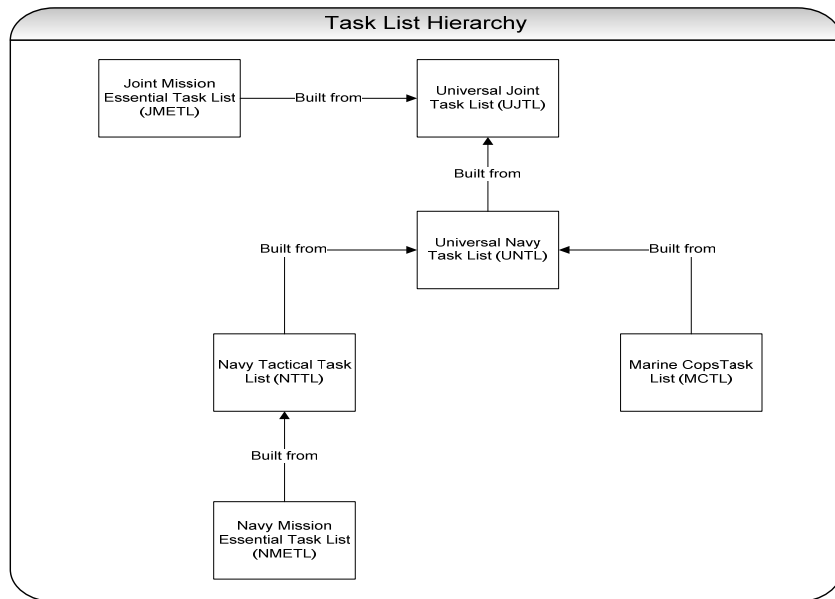


Figure 26. Task List Hierarchy



The following task list definitions were taken from the OPNAV Instruction 3500.38B/MCO 3500.26A/USCG COMDT Instruction M3500.1B CH-1:

- The UJTL (CJCSM 3500.04) is a comprehensive hierarchical listing of the tasks that can be performed by a joint military force. It serves as a common language and reference system for joint force commanders, combat developers, and trainers. The UJTL also provides a basis for describing joint requirements, capabilities, and combat activities.
- The UNTL (OPNAVINST 3500.38/) is a comprehensive hierarchical listing of Navy, Marine Corps, and Coast Guard tasks, at all levels of war (the UJTL plus the Naval Tactical Task List). It includes all those tasks the United States Navy, Marine Corps, and Coast Guard might be required to perform as part of their military missions.
- A Joint Mission Essential Task (JMET) is an activity selected by a joint force commander deemed critical to mission accomplishment. The UJTL (version 4.0) defines essential as “absolutely necessary; indispensable; critical.” The Joint Mission Essential Task List (JMETL) is the joint force commander’s list of joint tasks considered essential for accomplishment of operational plans predicated on the missions assigned and forces apportioned by the JSCP, U.S. alliance or treaty, or by regional initiatives.
- Naval Mission Essential Tasks (NMET) are those tasks considered essential to accomplish and support missions assigned by a naval or joint force commander. NMETs are chosen from the tasks contained in the UNTL.

In order to complete the mission requirements, the type of operation must be considered. Each mission will require a unique set of capabilities or operational activities due to the variation of the mission environment. Task lists are uniquely defined, based on a higher-level mission analysis of the variation in operational objectives. Although many of the tasks within the different lists are similar, task requirements will vary based on the type of operation. The different task lists are hierarchically displayed in Figure 27.

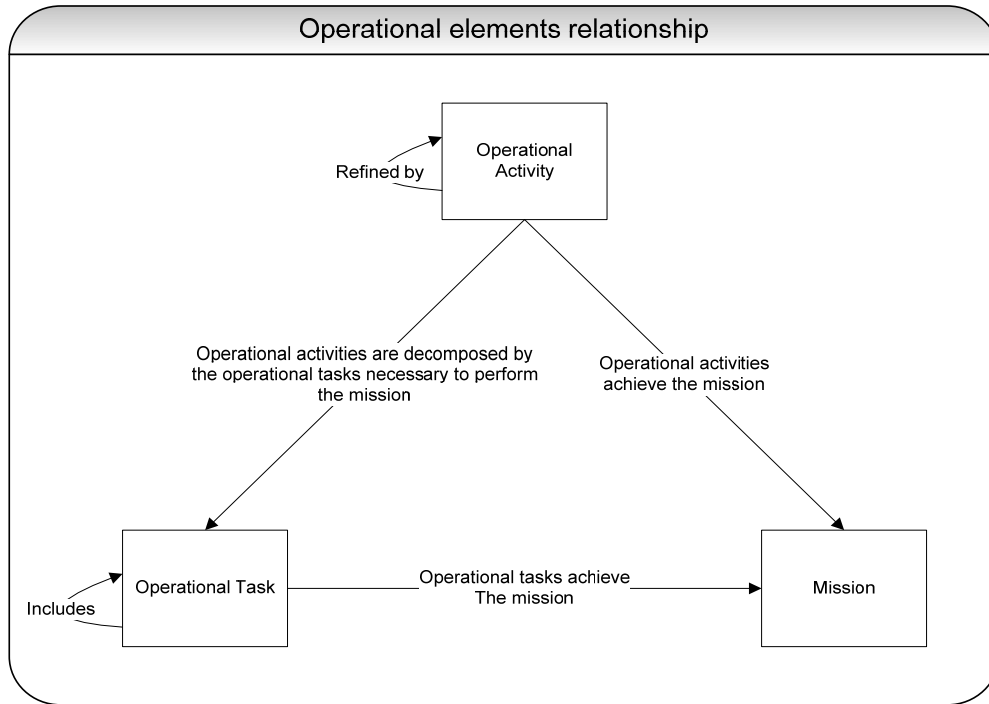


Figure 27. Mission-Op Task-Op Activity Diagram

As stated above, the task list identifies “what” is to be performed in terms of the system being designed. The following towing and salvage tasks were derived from the UNTL for the purpose of developing a CORE architectural model:

- Provide Damage Control.
- Conduct Small Boat Operations.
- Sail Ship from Port, Anchorage, or Moorage.
- Return Ship from Port, Anchorage, or Moorage
- Employ Remote Vehicles.
- Conduct Navigation.
- Conduct Ship-to-Shore or Ship-to-Objective Maneuver.
- Conduct Sustained Operations Ashore.
- Conduct Security.
- Conduct Passage of Lines.
- Transport Personnel.
- Transport Cargo.

- Provide Support Services.
- Employ Communication Security.
- Coordinate Damage Control Operations.
- Conduct Personnel Recovery.
- Perform Search and Rescue.
- Provide Disaster Relief.
- Provide Emergency Assistance.
- Provide for Operational Safety of Personnel and Equipment.
- Conduct Towing Operations.
- Conduct Salvage Operations.
- Retract Beached Vessels.
- Conduct Off-Ship Firefighting.
- Conduct Heavy Lift Operations.
- Conduct Diving Operations.
- Conduct Mooring.
- Conduct Underway Replenishment.

These tasks were derived to satisfy the capabilities needed in order to perform the higher-level tasks included in a simulated ROC/POE developed within the DRM. These tasks were used to identify the required operational activities necessary to complete the proposed DRM and further recognize the operational nodes responsible to meet mission needs.

## **6. Missions**

“Missions are hierarchically organized textual descriptions that define the very existence of the enterprise, and that are the ultimate goals and objectives that measure enterprise accomplishment from within different business functions and organizations” (Gorman, 2007). The first step in the architecting procedure is defining the problem(s) it will be built to solve, and ensuring the development and refinement of the correct data necessary to address the problem. The problem definition step in developing a system architecture achieves a reference mission, to which the operational activities of the

system will need to be demonstrated within a mission simulation. In CORE, the element relationship for the decomposition of the mission element was derived and displayed in Figure 28.

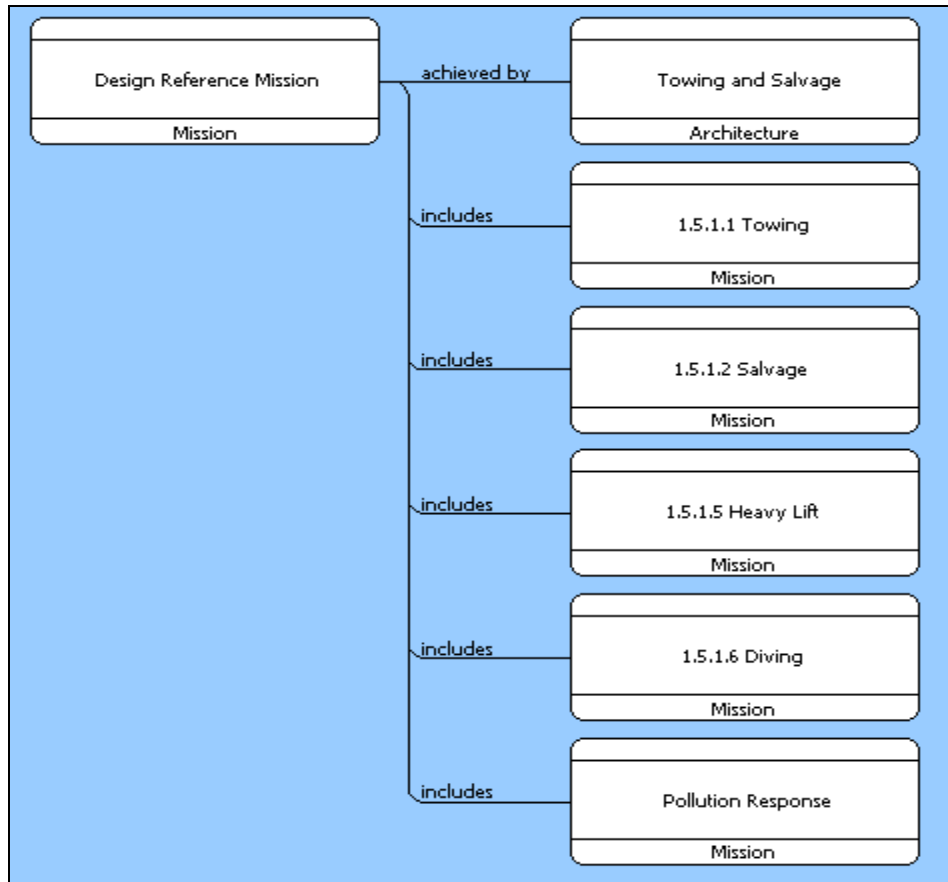


Figure 28. CORE view of the DRM decomposition

The basis for all of the required elements within the architecting model will be developed from a refined DRM. The capabilities from the DRM will drive the functions needed to implement the capabilities, followed by the system components needed to perform the functions. Once these elements have been identified, the architecting data model, CORE, will be utilized. According to Figure 28, the mission is directly achieved by the architecture.

## 7. Systems Architecture Considerations

SE activities needed to complete the architecture and interrelate the operational and systems domains are developed through the systems performance parameters, with

the integration of the component and function elements as a basis of the requirements (CORE ADG, 2007). The components with respective functions are derived from the operational activities needed to perform the mission. The example component type service (see Figure 29) is built from a system component to perform a service function.

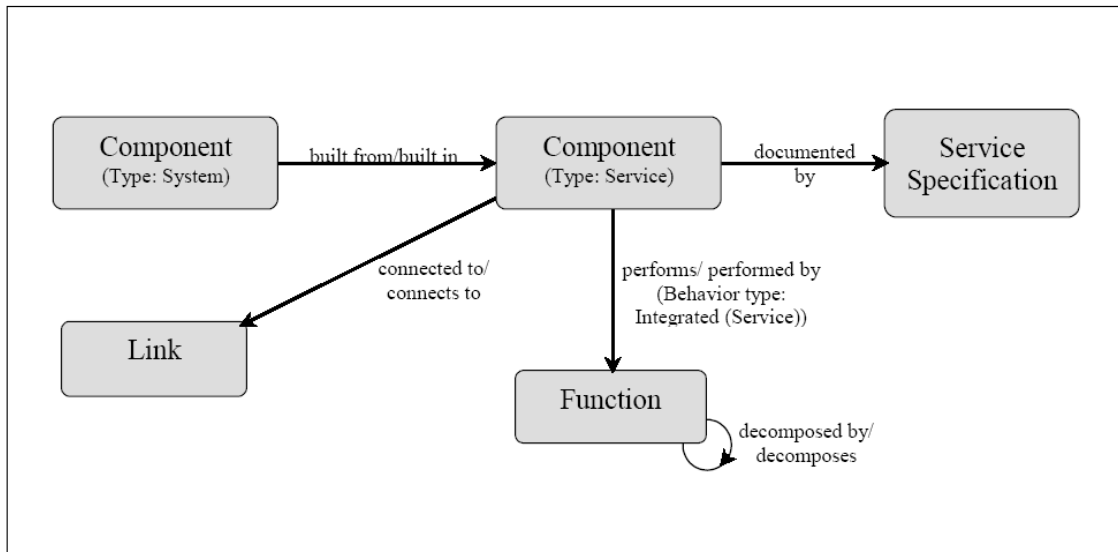


Figure 29. System Architecture component/function relationship example (From: Vitech, 2007)

## 8. Components

An objective of the system architecture is to identify what are its critical components and what are the relationships between all components within the system. “Components are represented in CORE as physical entities, including collections of systems, interfacing systems, and entities within the systems architecture” (CORE ADG, 2007). The components identified in this architecture range from higher-level systems like “ship” to lower-level individual components like “Diver davits.” Each component is organized within the Ship Work Breakdown Structure (SWBS), displayed in Figure 30, to define and categorize to boundaries in a ship’s systems and SoS.

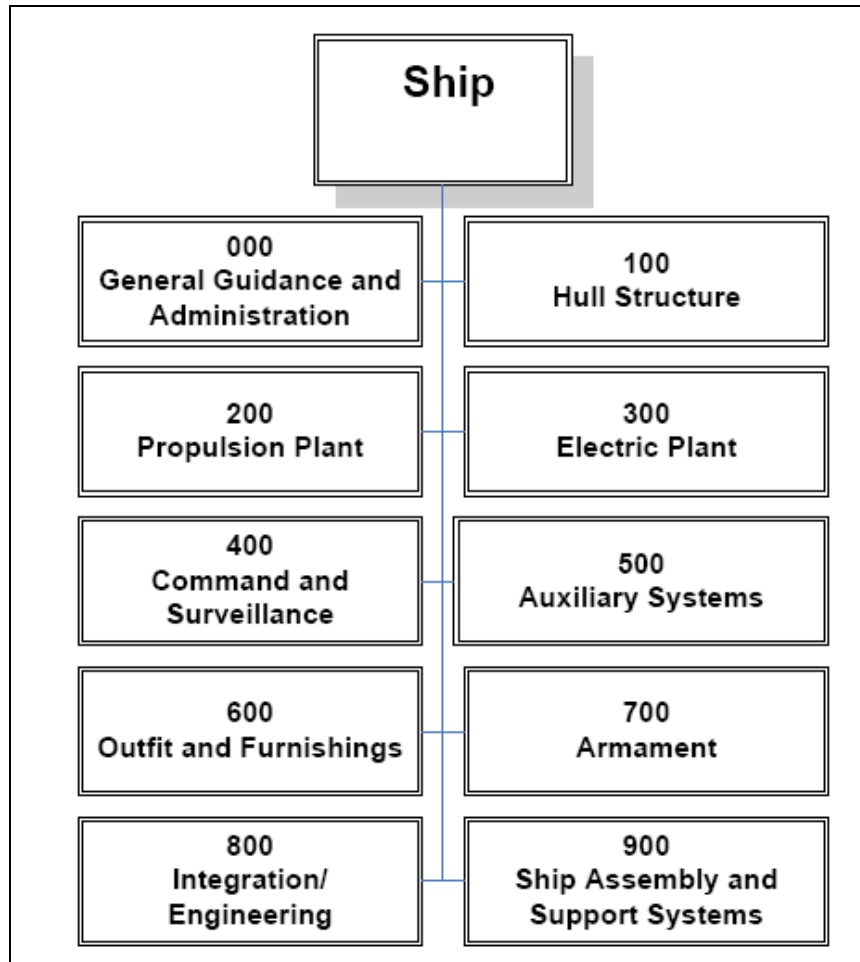


Figure 30. Ship Work Breakdown Structure (From: MIL-HDBK-881,1998)

A work breakdown structure (WBS) provides a comprehensible framework for system components within a program. It organizes the components in terms of hierarchically-related, product-oriented elements. Improved communication in management practices will be directly correlated to the generation of a WBS throughout the acquisition process.

The foundation for WBSs is contained in DoD Directive 5000.1 and DoD Regulation 5000.2-R. (MIL-HDBK-881, 1998). The SWBS structure shown in Figure 30 displays the ten major SWBS subgroupings that serve as an upper-level component classification for the towing and salvage architecture. All towing- and salvage-related components were entered into CORE, and organized into their respective SWBS groupings.

## 9. Functions

A function is the property of a system that, when performed, will fulfill a requirement for an objective. Functions are decomposed into lower-level functions (see Figure 31), until the individual components can be traced to a particular function to be performed. Functions are based on requirements that can be identified in the beginning stages of system development as desired characteristics. The functions identified for the towing and salvage platform are based on all the operational activities required to achieve the missions that the towing and salvage community is required to perform.

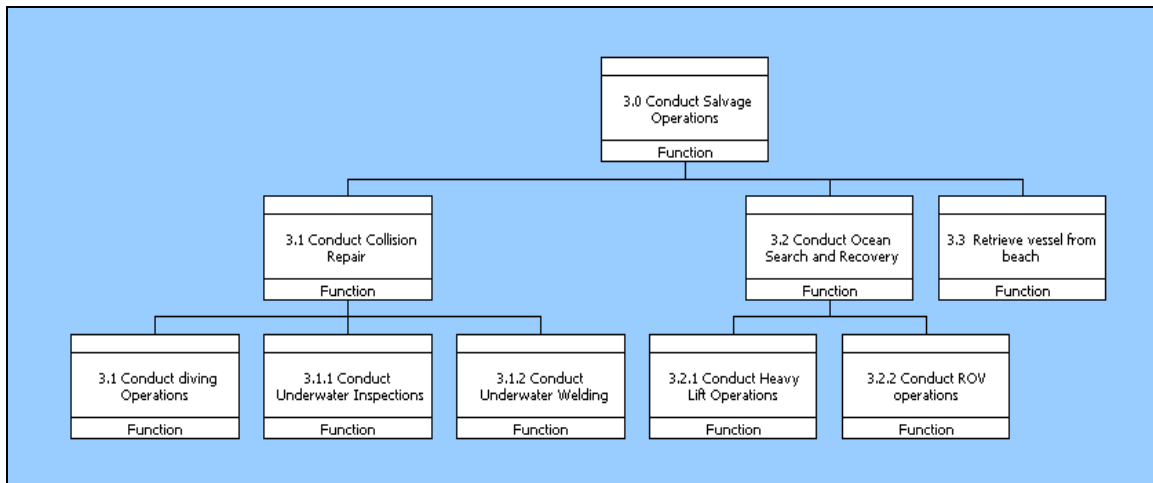


Figure 31. CORE view of the functional decomposition of “Conduct Salvage Operations”

Functional decomposition refers to the process of organizing the functional relationships into its components or systems for the purpose of defining the identity of the components. Specifically, what function must be provided to accomplish the mission requirements and how will that function be fulfilled by use of a system component?

## 10. Functional Requirements

Requirements are the basis of a function and usually specify the goals of the system. “Requirements development occurs when operational activities and performance characteristics serve as sources for system requirements” (CORE ADG, 2007). Operational activities lead to the identification and definition of functional requirements that, when added to the identification of performance characteristics, results in system

requirements. Thus, a requirement is a result of an operational activity and a performance characteristic, as displayed in Figure 31.

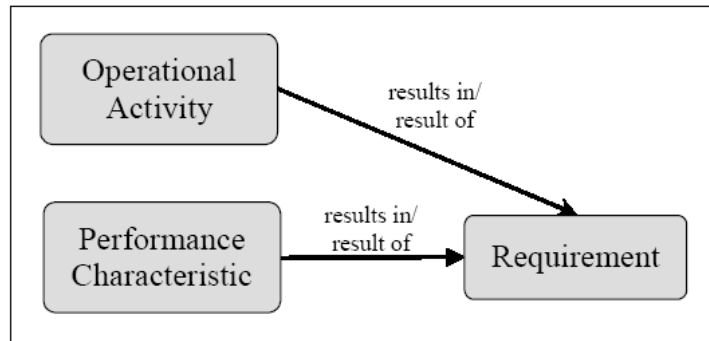


Figure 32. Requirements generation process (From: Vitech, 2007)

The requirements generated from a capability-need, MBSE methodology are a complete set of requirements that will be a basis for the system specification document. The generated requirements were compared with the given set of requirements from SUPSALV (see Table 8), to produce a comparative analysis of requirements-based system modeling versus capability-based system modeling.

CHARACTERISTIC	(THRESHOLD/OBJECTIVE)
Speed (knots sustained)	15/20
Bollard Pull (tonnes)	150; T=O
Navy Personnel Accommodation	42; T=O
Civilian Crew Accommodation	15; T=O
Positioning/Mooring	DP-2/DP-3. + 4 Point Moor; T=O
Endurance	8,000 nm @ 8 kt/12,000 @10 kt
Unobstructed Deck Space; AFT	3600 ft <sup>2</sup> ; T=O
Crane: Lift Capacity Min. 110 Tonnes SWL	(Amidships/Amidships + Stern)
Crane: FWD	Min. 10 Tonnes SWL; T=O
Towing	<ul style="list-style-type: none"> <li>- Twin Drum</li> <li>- 3" wire x 3,500 ft</li> <li>- Traction Winch</li> <li>- Shark Jaws</li> <li>- Auto-tow Pins</li> <li>- Portable Tow-bow</li> </ul>
R & A Firefighting	4 monitors @ 10K + GPM Min. Each; AFFF Capable; T=O
Interoperability	Deck Loading and Ship Service Support For: <ul style="list-style-type: none"> <li>- FMGS</li> <li>- Deep Ocean Search and Recovery</li> <li>- SAT-FADS</li> <li>- SRDRS (RCS only/TUP with ADS)</li> <li>- Submarine Salvage Support</li> </ul>

Table 8. SUPSALV Towing and Salvage Platform primary requirements (From: SUPSALV, 2007)



The primary/critical performance requirements given by SUPSALV match the high-level, capability-based requirements that were generated by the CORE model-based SE tool. The CORE tool can produce a complete capability-based requirements list, with all mission-based functions accounted for and mapped to all respective lower-level components.

## **11. Nonfunctional Requirements**

Nonfunctional requirements identify criteria that can be used to evaluate the system's operation instead of identifying specific functions or behaviors of the system. In general, nonfunctional requirements define how a system is supposed to operate rather than what it is supposed to do. Nonfunctional requirements are sometimes referred to as "ilities," e.g., availability and survivability, which describe the criteria in which the system can be evaluated. Within the CORE architecting tool, nonfunctional requirements are not present within the schema, but are present within requirement class with the type attribute set to "Constraint."

The process starts with extracting the originating requirements into the requirements class and then set the "type" attribute to (Functional, Performance, Constraint, or Verification). A Functional requirement will be modeled with "Function" and the nonfunctional requirements (except for performance) will be addressed by one of the specialty engineering disciplines.

Nonfunctional requirements will be clearly defined and utilized when creating a simulation based on the CORE model. The availability and/or survivability of a system cannot be determined without being able to simulate all of the components working together within an SoS, to include the environment.

## **D. TOWING AND SALVAGE SPECIFIC METHODOLOGY**

The CORE architecture schema has many other elements which connect with and influence the interoperability of the architecture. The focus has been on the major elements which directly influence the capabilities of the system based on the previously defined mission. The major elements focused on in this thesis, when completed, generate the necessary architectural views that will lay the foundation for the future towing and

salvage platform architecture. These elements, along with the architecture process steps taken for a comprehensive architectural view development, are displayed in Figure 33.

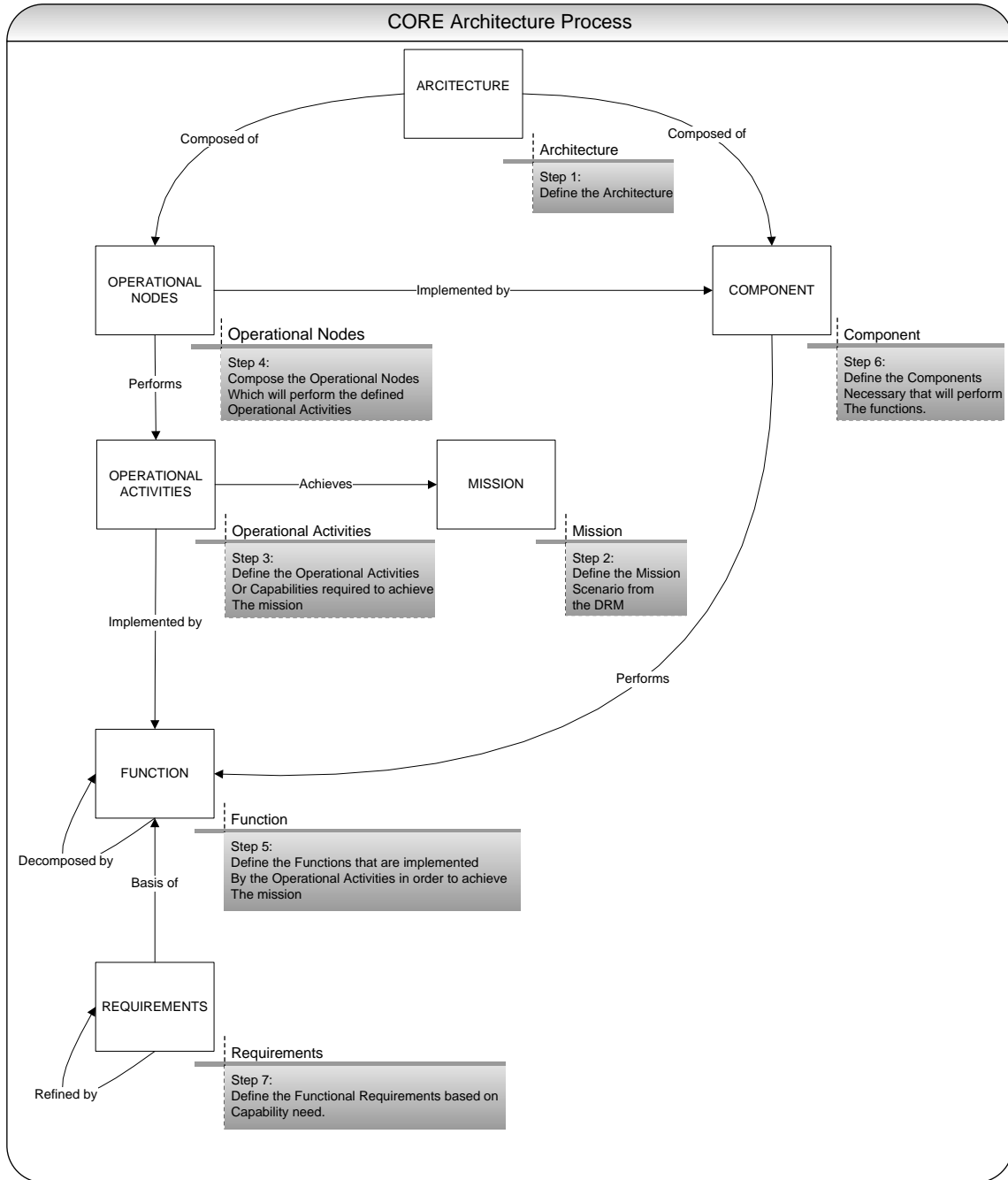


Figure 33. Methodology for CORE Towing and Salvage architecture development

The steps taken in the architecture process displayed in Figure 33 are based on a methodology built from the DRM capability need. The mission requirements are

generated by a DRM that would require the combined capabilities of both towing and salvage platforms. Beginning with defining the architecture, the DRM was developed to incorporate the full functional potential of the towing and salvage activities. The next step in the process was to define the operational activities necessary to achieve the identified mission requirements, as well as link them to the operational nodes responsible for conducting those activities. The activities are also built from, and decomposed by, the standardized operational tasks linked to the individual mission tasks. Once the activities are identified, a functional requirements generation process is initiated, based on a functional hierarchy from the components necessary to complete the mission tasks. Finally, all elements are then redefined, decomposed, and linked to their schema element relationships.

The proper development of an integrated towing and salvage architecture requires a comprehensive modeling technique based on well-specified, capability-based requirements. To properly guide architecting, design, and integration of this diversity of system elements, we have developed a comprehensive towing and salvage SoS architecting method that addresses all facets of the mission capabilities of the proposed SoS, such that it will fully meet the needs of the towing and salvage community (Whitcomb, 2008). The convergence of SoS engineering with CORE architecting techniques will lead to a system definition incorporating all desired capabilities of the system, with considerations to utilize commercial towing and salvage capabilities.

The architecting of the towing and salvage SoS starts with the transformation of an operational capability need, based on mission requirements, into a set of functional and physical requirements that are used to guide the development of operational and system architectures. This process establishes a set of physical requirements to which the future towing and salvage platform can be defined. Essentially, without a comprehensive architecture based on mission requirements that includes a well-developed set of specifications, an integrated SoS cannot be successfully realized (Whitcomb, 2008).

## **E. SUMMARY**

The SE process was defined in Chapter I without any focus on capability-based architecting. This thesis has defined the need for recognizing the capabilities based on

mission requirements. The need for MBSE has also been recognized and a model-based architecting process has been developed, based on the fusion of SE and systems architecting. The differences between SE and systems architecting have been established, showing the benefits of what each can bring to a system design. Figure 34 displays the collective approach of the MBSE process developed in this thesis to include:

- Capability need recognition.
- Customer need/desired capabilities input.
- Typical SE process.
- CORE architecture design process.

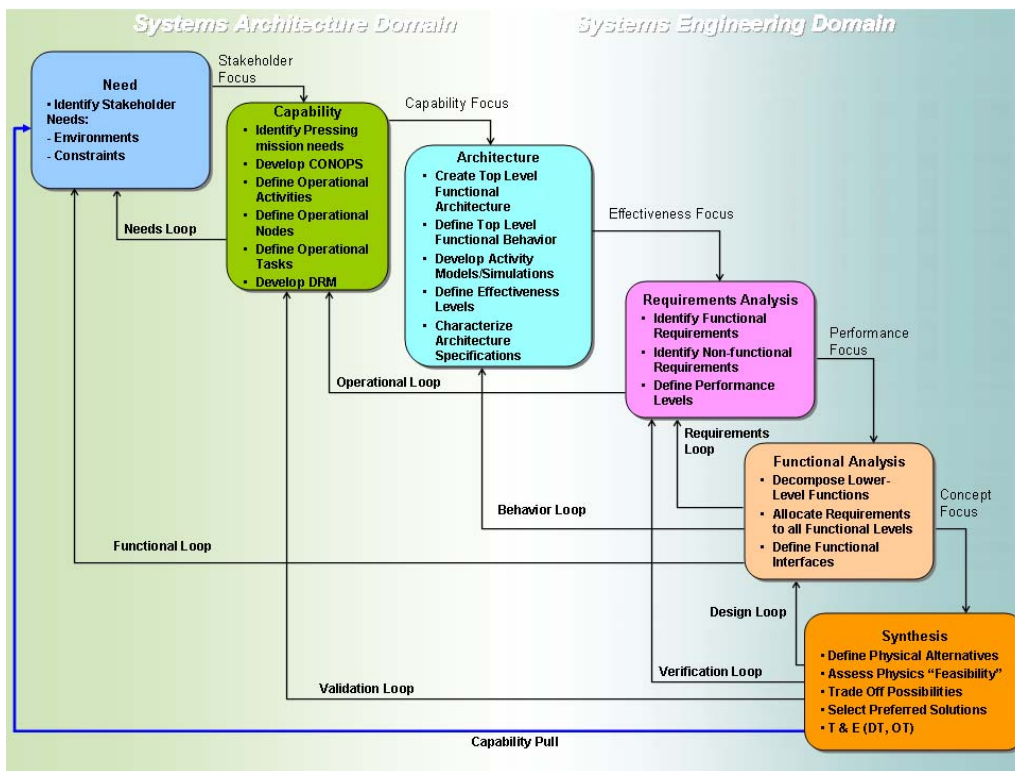


Figure 34. Composite MBSE process

Future T-ARS(X) operations will require an unprecedented level of integration among joint towing and salvage capabilities. The towing and salvage community's increased demand for a mission-tailored future salvage platform requires a more integrated approach to T-ARS(X) requirements generation. Along with a towing and salvage force simulation, MBSE can achieve a comprehensive platform design for either build or buy recapitalization strategy.

THIS PAGE INTENTIONALLY LEFT BLANK

## V. ARCHITECTURE RESULTS

### A. DoDAF VIEWS

The DoDAF is described in detail in Chapter I and its views will be demonstrated in this chapter. As described earlier, the DoDAF displays and organizes a complex systems architecture into consistent views, showing interoperability within the system elements. Representations for the DoDAF products are drawn from the diagramming technique Entity-Relationship Diagrams (ERDs), found in the CORE model. The different architecture views, along with the view descriptions, are displayed in Table 9.

Applicable View	Framework Product	Framework Product Name	General Description
All Views	AV-1	Overview and Summary Information	Scope, purpose, intended users, environment depicted, analytical findings
All Views	AV-2	Integrated Dictionary	Architecture data repository with definitions of all terms used in all products
Operational	OV-1	High-Level Operational Concept Graphic	High-level graphical/textual description of operational concept
Operational	OV-2	Operational Node Connectivity Description	Operational nodes, connectivity, and information exchange needlines between nodes
Operational	OV-3	Operational Information Exchange Matrix	Information exchanged between nodes and the relevant attributes of that exchange
Operational	OV-4	Organizational Relationships Chart	Organizational, role, or other relationships among organizations
Operational	OV-5	Operational Activity Model	Capabilities, operational activities, relationships among activities, inputs, and outputs; overlays can show cost, performing nodes, or other pertinent information
Operational	OV-6a	Operational Rules Model	One of three products used to describe operational activity— identifies business rules that constrain operation
Operational	OV-6b	Operational State Transition Description	One of three products used to describe operational activity— identifies business process responses to events
Operational	OV-6c	Operational Event-Trace Description	One of three products used to describe operational activity— traces actions in a scenario or sequence of events
Operational	OV-7	Logical Data Model	Documentation of the system data requirements and structural business process rules of the Operational View
Systems	SV-1	Systems Interface Description	Identification of systems nodes, systems, and system items and their interconnections, within and between nodes
Systems	SV-2	Systems Communications Description	Systems nodes, systems, and system items, and their related communications lay-downs
Systems	SV-3	Systems-Systems Matrix	Relationships among systems in a given architecture; can be designed to show relationships of interest, e.g., system-type interfaces, planned vs. existing interfaces, etc.
Systems	SV-4	Systems Functionality Description	Functions performed by systems and the system data flows among system functions
Systems	SV-5	Operational Activity to Systems Function Traceability Matrix	Mapping of systems back to capabilities or of system functions back to operational activities
Systems	SV-6	Systems Data Exchange Matrix	Provides details of system data elements being exchanged between systems and the attributes of that exchange
Systems	SV-7	Systems Performance Parameters Matrix	Performance characteristics of Systems View elements for the appropriate time frame(s)
Systems	SV-8	Systems Evolution Description	Planned incremental steps toward migrating a suite of systems to a more efficient suite, or toward evolving a current system to a future implementation
Systems	SV-9	Systems Technology Forecast	Emerging technologies and software/hardware products that are expected to be available in a given set of time frames and that will affect future development of the architecture
Systems	SV-10a	Systems Rules Model	One of three products used to describe system functionality— identifies constraints that are imposed on systems functionality due to some aspect of systems design or implementation
Systems	SV-10b	Systems State Transition Description	One of three products used to describe system functionality— identifies responses of a system to events
Systems	SV-10c	Systems Event-Trace Description	One of three products used to describe system functionality— identifies system-specific refinements of critical sequences of events described in the Operational View
Systems	SV-11	Physical Schema	Physical implementation of the Logical Data Model entities, e.g., message formats, file structures, physical schema
Technical	TV-1	Technical Standards Profile	Listing of standards that apply to Systems View elements in a given architecture
Technical	TV-2	Technical Standards Forecast	Description of emerging standards and potential impact on current Systems View elements, within a set of time frames

Table 9. DoDAF architecture views descriptions (DODAF, 2004)

CORE documents the architecture product as a Rich Text Format (RTF), via scripts that generate a standard DoDAF diagram. The DoDAF version 1.5 view scripts are designed to be flexible in order to support any later iteration (Vitech, 2007). Figure 35 displays the integration of the SE process steps with each DoDAF view production ability based on time.

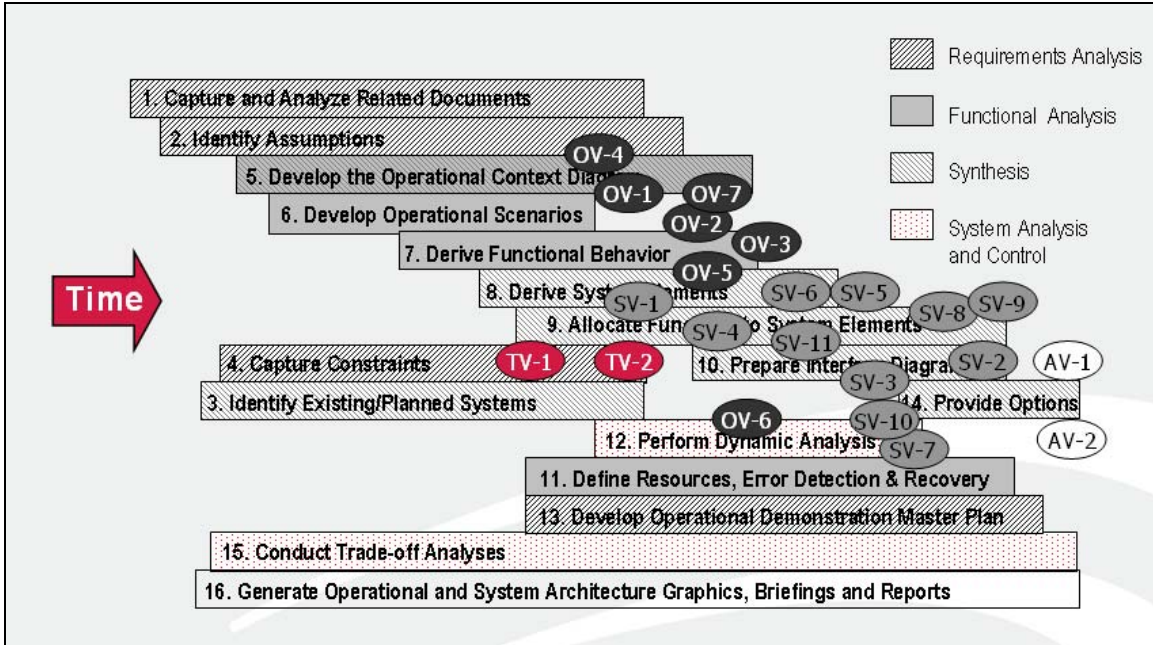


Figure 35. CORE integration of the typical systems engineering process with DoDAF views milestones (From: Vitech, 2008)

From an SE perspective, the DoDAF architecture views OV-2, OV-5, and SV-4 are the most important views because they lay the foundation for the operational architecture (structure, behavior, interfaces) and provide a basis for developing the system architecture. For the purpose of this thesis, the OV-2, OV-5, and SV-4 are developed and discussed. A System Design Document (SDD) is added for reference in Appendix A.

The SDD describes how the functional and nonfunctional requirements and CONOPS are transformed into system design specifications. The SDD developed with this architecture is a high-level, first-iteration example in order to document and display the system design through detailed design specifications. The SDD gives a high-level overview of the system architecture and is a formal documentation process for

requirements generation that can be used to design the new towing and salvage platform. More component-specific results can be obtained from the SDD, which was also used as the detailed design reference for requirements generation. These requirements were compared to the current commercial market capabilities outlined in Appendix B.

Operational views detail the user’s operating domain in which the developing system will operate (Zachman, 2007). The OV-2 is an operational node connectivity description, which displays the relationships between the nodes as well as organizes the nodes into an operational hierarchy. The operational node relationship hierarchy from SEA 00C is displayed in Figure 36.

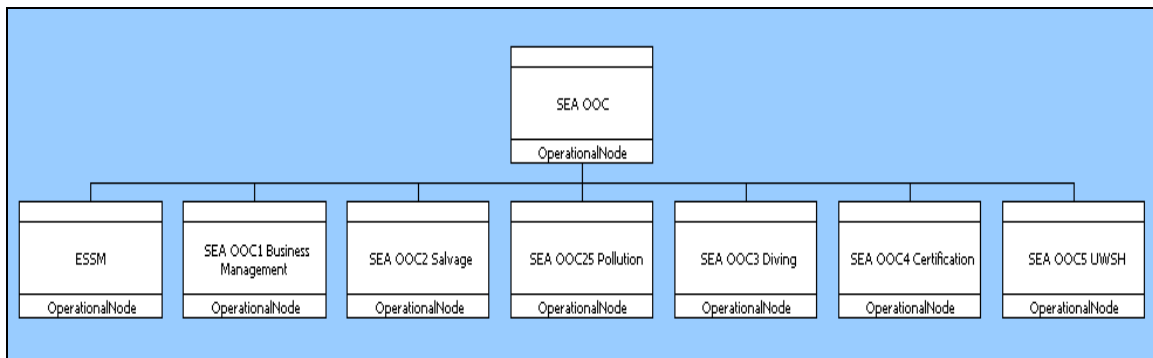


Figure 36. SEA 00C SV-2 architecture view

The OV-5 DoDAF view is an activity model that identifies and displays the hierarchical decomposition of an operational activity, as well as show the relationships between the capabilities and activities in which each activity is interconnected. The OV-5 Activity Model for Conduct Towing and Salvage DRM hierarchy is displayed in Figure 37.



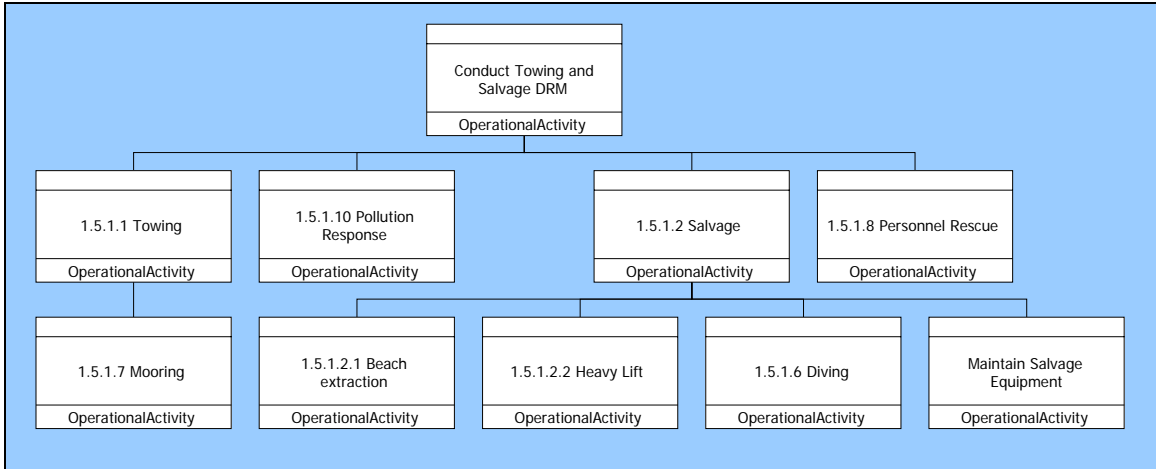


Figure 37. “Conduct Towing and Salvage DRM” Hierarchy Diagram

The Conduct Towing and Salvage DRM IDEF0 diagram illustrates the children or offspring operational activities with the user-selected operational nodes. This operational activity model graphically organizes the activities in a hierarchy, clarifying the level at which each function is required. Figure 38 is the IDEF0 diagram, depicting which operational nodes perform the “Conduct Towing and Salvage DRM” operational activities. The overlap within the activities demonstrates the actions performed by the operational nodes.

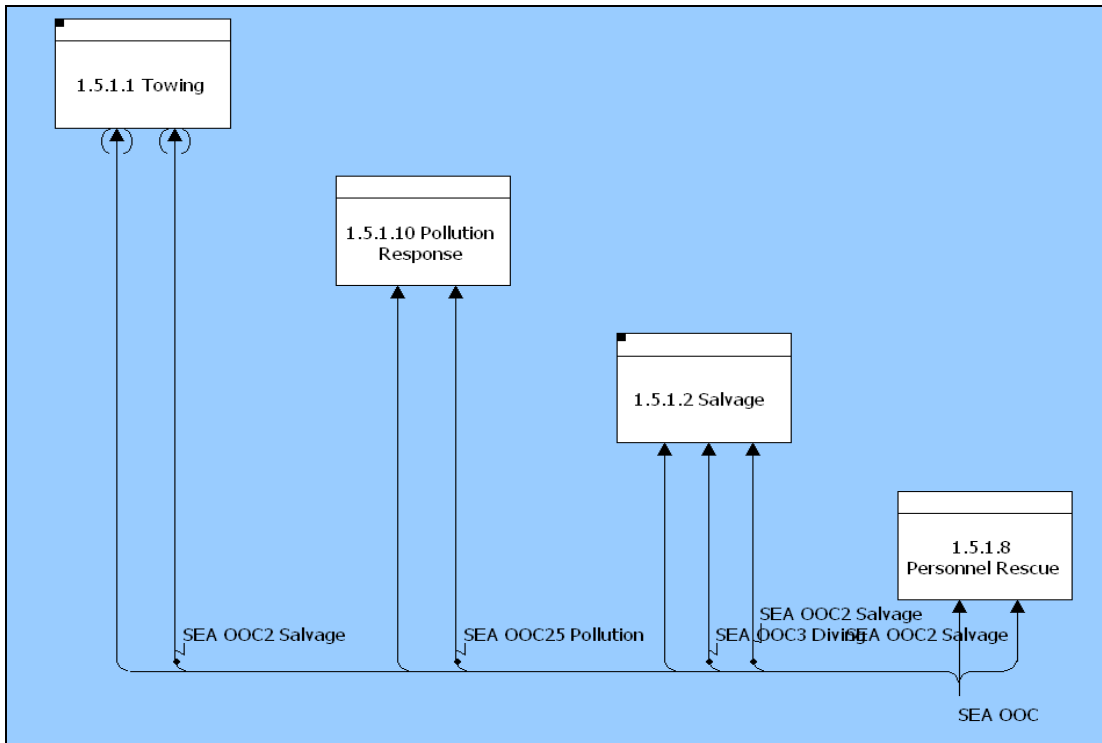


Figure 38. “Conduct Towing and Salvage DRM” IDEF0 Diagram

Within the OV-5, each of the children operational activities can be analyzed, along with their activity relationships among their corresponding operational nodes. Figure 39 displays the IDEF0 diagram of the “Salvage” operational activity.

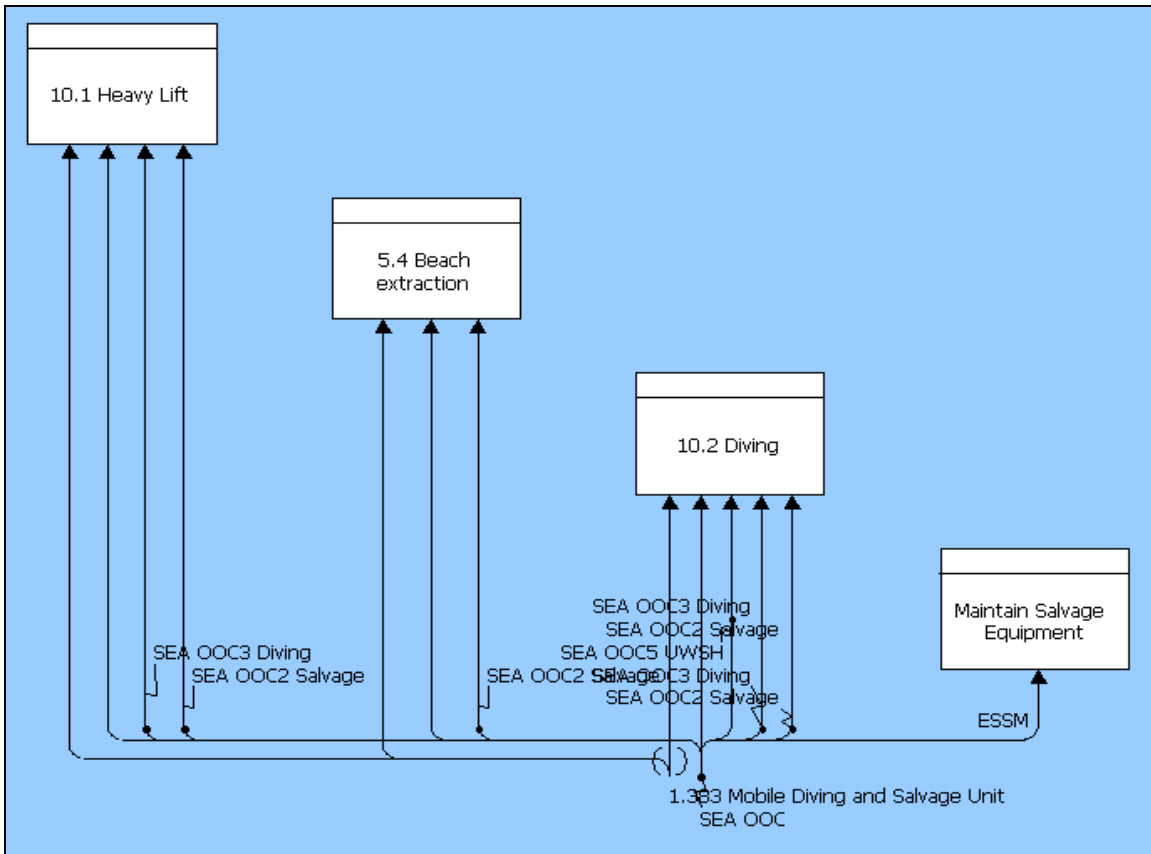


Figure 39. “Salvage” IDEF0 Diagram

The DoDAF system and service view is a set of graphical products that describe systems and interconnections that support DoD functions. SV products focus on specific systems with specific physical locations. “The relationship between architecture data elements across the SV to the OV can be exemplified as systems are procured and fielded to support organizations and their operations” (DoDAF, 2007). The system and service view focused on in this thesis is the SV-4 view, which documents the system data flows between functions. Figure 40 displays the SV-4 hierarchy for the function “Conduct Towing Operations.” When developing a complete architecture, the level of detail from a functional decomposition within the SV views will ensure sufficient system design.

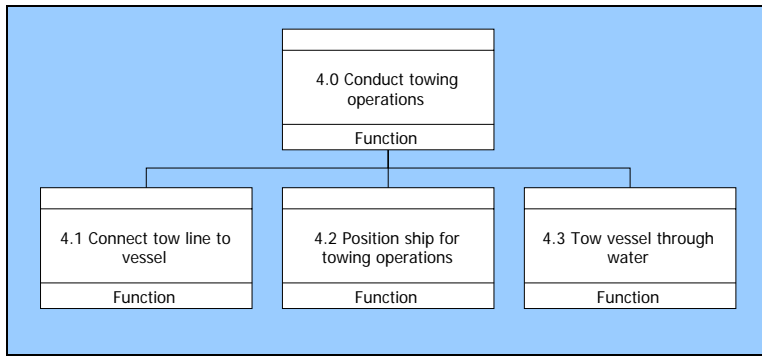


Figure 40. “Conduct Towing Operations” Hierarchy Diagram

This SV-4 documents the functional relationships of just one of the functions within the system and can be expanded to include all system functions. The “Conduct Towing Operations” function can be displayed with the component relationships necessary to achieve the functional requirement. The IDEF0 context diagram is displayed in Figure 41.

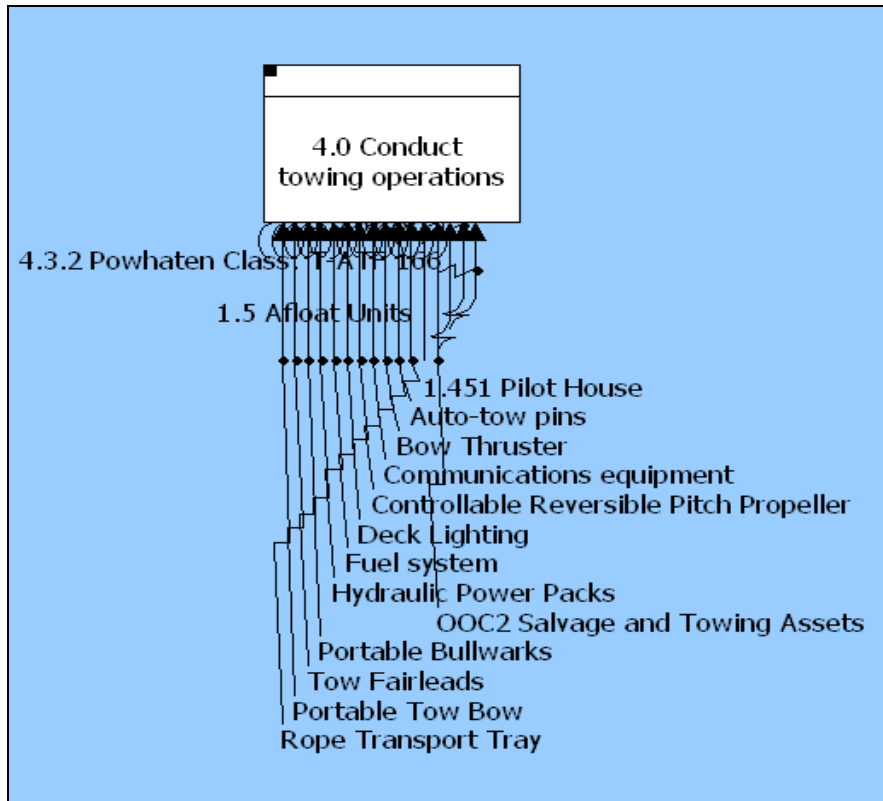


Figure 41. “Conduct Towing Operations” IDEF0 A-0 Context Diagram

The SV-4 function can be decomposed, showing the functional breakdown of the “Conduct Towing Operations” function with the component-to-function individual relationships. Figure 42 displays the IDEF0 diagram of the functions necessary to perform the “Conduct Towing Operations” function.

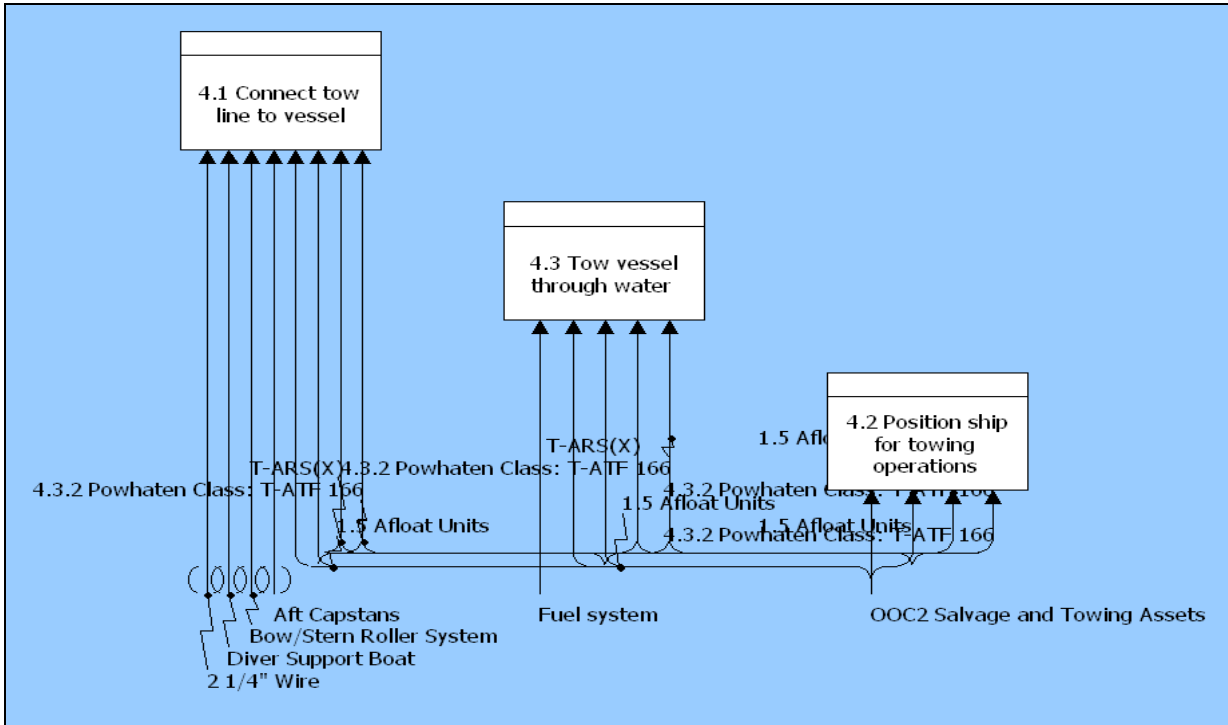


Figure 42. “Conduct Towing Operations” IDEF0 Diagram

From the DoDAF views generated in this thesis, a ship can begin a preliminary design phase based on the requirements generated with function-to-component relationships defined. Table 8 displays the top-level requirements desired by the program manager, based on current ARS/T-ATF capabilities for potential future mission needs. The customer’s desires and system requirements have been identified and verified to achieve a combined towing and salvage mission. Lower-level requirements generation must be developed in order to generate a complete analysis of the buy versus build options. A top-level commercial market analysis, mapping the capabilities to the architecture as an analysis of alternatives, is demonstrated below. In the CORE schema, these commercial capabilities are captured as resources for a potential T-ARS(X) simulation.

## B. COMMERCIAL TOWING AND SALVAGE MARKET ANALYSIS

Figure 43 displays the top-level, T-ARS(X) requirements compared to the current commercial capabilities. Not all desired or derived requirements were analyzed due to the level of focus needed to outline the method implemented in this thesis. These requirements were deemed critical or mission essential because if any of the selected requirements cannot be met, based on T-ARS(X) mission need as mapped in the architecture, the joint towing and salvage capability cannot be achieved.

	Speed	Bollard Pull	Navy Personnel Accommodation	Civilian Crew Accommodation	Positioning	Endurance	Unobstructed Deck Space, Aft	Crane: Lift Capacity, Aft	Crane: Fwd	Ice Classification
<b>Vessels of Opportunity</b>	16/20	125/175	40; T=0	15; T=0	DP-2/DP-3	8,000 nm @ 8 kt / 12,000 @ 10 kt	3000 sqft / 4300 sqft	Arndships / Arndships + Stern	10 short tons SWL; T=0	ABS Ice Class C0; T=0
1 Noordhoek Diving Construction support vessel	12 knots	44mT	55	15	DP-2		7373 sqft	110.2 sh	30 mT	
2 Trans Viking AHTS/VS 4622 CD	12 knots	220 ts	185	15	DP-2		8223 sqft			
3 Rolls-Royce UT-design UT 719-2		85 ts	185	15	DP-2		4477 sqft	5 ts		
4 Gulf M.V CLWYD Supporter	14 knots	105 t					3907 sqft	6 ts		Ice-C
5 Merwede Seven Atlantic Diving Support Vessel	13.6 knots		135	15	DP-3		12916 sqft	150 mT	10 mT	
6 Merwede HOS Superior Acheiver	13 knots		84	15	DP-3		16145 sqft	140mT	160 mT	
7 Nomis DEA Olympian	13 knots	150 t	30	12			4305 sqft			
8 Nomis DEA Signal	12 knots	150 t	12	12			4660 sqft	2.5 t		
9 Noordhoek Singapore	12 knots	38 t	21	15	DP21		3336 sqft	25 t		
10 Sealion Tiosa Pegasus	13 knots		84	15	DP21		12916 sqft	400 mt	7 mt	
11 Sealion Toisa Paladin	15.5 knots		85	15	DP-2		9687 sqft	140 t	30 t	
12 Sealion Toisa Polaris	13.25 knots		83	15	DP-3		7534 sqft	150 t	10 t	
13 Sealion Toisa Proteus	15 knots		145	15	DP-3		20451 sqft	196 t	19 t	
14 Ulstein A102	17.5 knots	200 t	20	15			5100 sqft			
15 Ulstein P101	16 knots		45	15			11500 sqft	100 t	0	
16 Farstad BOS Topazib	15.5 knots	150 t					6000 sqft	10 t	10 t	
17 Farstad Far Saga	15.5 knots						6200 sqft	100 t	20 t	
18 Farstad Far Sapphire	17 knots	261 mt					8500 sqft	20 t	3 t	

Figure 43. Commercial capabilities with requirements comparison

The vessels of opportunity are derived from a complete list of available commercial platforms and are considered to be the closest match to the generated requirements. All cells highlighted in blue either meet the requirement or surpass the

lower limit of the requirement. Yellow is close and can be improved, while red will not meet the requirement, even with improvements. Bollard pull and crane lift capacity are two contracting requirements that seem impossible to met simultaneously. Bollard pull, defined in Chapter II, is the ability of a vessel to tow a certain weight. Not all of these platforms are designed to tow, but have the ability if configured correctly. The platforms that do not have ample crane lift ability can be configured with an additional crane to meet that requirement.

All of the desired performance requirements/characteristics are based on a perceived mission need and were documented as an estimate of future use. CORE can provide accurate requirements documentation based on mission need. Components are the lower-level elements of the architecture which is based on a defined mission described in Chapter III. The functions are performed by components and are necessary to achieve the mission capability. The SUPSALV desired characteristics are verified to fulfill a mission need in CORE. Table 10 displays how each desired T-ARS(X) characteristic should be architected.

	<b>Desired Performance Characteristics</b>	
<b>Characteristic</b>	<b>(Threshold/Objective)</b>	<b>Should be obtained from a MBSE architecture</b>
Speed	15/20	Based on sea basing/DRM
Bollard Pull	125/175	Based on function implements capability
Navy Personnel Accomodation	42; T=0	Based on component architecture simulation
Civilian Crew Accomodation	15; T=0	Based on component architecture simulation
Positioning	DP-2/DP-3	Standard ship system requirement
Endurance	8,000 nm @ 8 kt / 12,000 @ 10 kt	Based on sea basing/DRM
Unobstructed Deck Space; Aft	3600 sqft / 4300 sqft	Based on mission needs
Crane; Lift Capacity	120 short tons SWL	Based on function implements capability
Crane; Fwd	10 short tons SWL; T=0	Based on function implements capability
Ice Classification	ABS Ice Class C0; T=0	Based on sea basing/DRM
Stability	Adequate metacentric height, 30 yr service life	Standard ship system requirement
Unobstructed Deck Space; Fwd	720 sqft; T=0	Based on mission needs
Survivability	Commercial Salvage Standards, ABS Classification	Standard ship system requirement

Table 10. Desired performance requirements mapping process

Based on the analysis of the commercial market compared to the MBSE-generated requirements, a top-level system design with consideration of available capabilities has been developed. The architecting process, with implied T-ARS(X) characteristics, has been mapped to a verifiable set of requirements for future ship design. The results indicate a gap in bollard pull and crane lift capacity for commercial platforms. The final step in this analysis would be to analyze the cost comparison of outfitting the missing requirements on the commercial platforms with building a new platform.

### C. SUMMARY

The architecture demonstrated in this chapter highlight some of the more important DoDAF views, but they barely scratch the surface of the potential towing and



salvage architecture development available in the CORE modeling tool, for a final SoS development. The SDD in Appendix A is one of many official documents that be produced by the push of a button, once the elements have been completed and linked accordingly. Capabilities-based architecting approach for the recapitalization of the future towing and salvage platform has been demonstrated, providing a high-level/first-iteration of requirements generation.

## **VI. CONCLUSIONS AND RECOMMENDATIONS**

While the Navy continues its internal debate on which direction to pursue for surface ships, the service has begun to lay down the ground work, schedules and goals for implementing open systems architecture in order to reduce the cost and speed up the time cycle for delivering capabilities to warfighters (Fein, 2008).

### **A. CONCLUSIONS**

The Navy has been analyzing the process of how to require open architecture in new contracts. The DoD has changed their philosophy of stove-pipe design to developing integrated architectures based on capability needs. Along with the JCIDS process, the DoDAF and NAERG provide a basis for defining standard architecture elements for future SoSs. As the Navy changes its approach to developing new SoSs from capability need, a standard SoS architecting process definition is required.

What has been demonstrated in this thesis is an systems architecting approach that is not only traceable from a realizable mission need, to top-level system requirements, to system function and components, but provides a fully interconnected relationship among all architectural elements. An architecture was created that can be revised, rerun, and moved around in an interactive manner in order to explore the design space of a comprehensive and efficient system design. The recapitalization of a towing and salvage vessel was used as an objective or need to define an architecting process. The architecture process was an interactive methodology using the CORE DoDAF 1.5 schema to produce necessary architecture views and design documents. This process provides a useful methodology to demonstrate the capabilities needed by the towing and salvage community for joint, towing, and salvage operations.

This thesis outlined the first-iteration of a MBSE process, illustrating the manner of how an SoS is engineered in the context of an architecture. The CORE architecting tool was utilized to develop an SDD, as well as key DoDAF views for consistent and complete requirements generation, based on towing and salvage capability needs. High-level functional and nonfunctional requirements were developed and compared with the requirements generated by SUPSALV for optimum future platform performance

characteristics. The consolidated requirements were then compared to the commercial market for future analytical development of recapitalization strategies.

From a top-level requirements view, the commercial market has vast opportunities for a potential future U.S. Navy combined towing and salvage platform. The two key requirements that prohibit an immediate and complete comparison between U.S. Navy needs and commercial market capabilities are crane ratings and bollard pull. Commercial ships were designed for either heavy-lift-salvage and diver interoperability or they were designed for towing large vessels. A combined-capability commercial platform could be redesigned or outfitted with the missing capability. The cost of developing a commercial replacement vessel should be explored further.

The U.S. Navy towing and salvage community can benefit from an open, integrated architecture model of a complete system, based on the capability-need from mission requirements. Using the data from the UNTL, NAERG, and towing and salvage CONOPS, a combined platform can be realized with a logical and complete set of requirements, modeled after what is needed vice what is already utilized.

## **B. RECOMMENDATIONS**

The need for a towing and salvage community analysis of a build or buy ship recapitalization strategy substantiates the need for a comprehensive simulation of capabilities. The two main objectives to the analysis are:

1. Independent towing and salvage platforms or single-hull combined capability.
2. Build the future platform or purchase from the commercial community.

To satisfy the objectives, an analysis of future mission needs must be conducted, along with a market analysis of the commercial ships with cost estimates on improvements. The need for an architecture model that contains all towing and salvage information, including all required tasks and potential components, must be developed. Once a comprehensive model has been built, a simulation must be conducted to include scenarios that utilize single-hull towing and salvage platforms, as well as independent

platforms. The development of the overall diving and salvage architecture, and the simulation of the use of the architecture for strategic and operational decision making should be accomplished. This includes:

- Developing an architecture that is populated to the extent that elements include enough description to demonstrate the use for operational and strategic planning, including the need for trade-offs for acquiring new platforms or contracting of outside resources (Whitcomb, 2008).
- Exercising the architecture in a dynamic sense to create options for planning and design (Whitcomb, 2008).
- Integrating the architecting process and respective tools (e.g., CORE) with ship design tools (e.g., ASSET, POSSE) in order to allow a more quantitative, physics-based analysis of ship platform development, and connect the traditional ship design process to the stakeholder's need (Whitcomb, 2008).
- Expanding the process scope to core warfighting capabilities and business capabilities, such as combatant ships, aircraft, ground vehicles, and system command organizations (Whitcomb, 2008).
- Utilizing and incorporating all task lists to include the UNTL, UJTL, and NMETL, with real-time updates as missions get redefined.
- Revising the CORE schema to include a separate capabilities element, which links operational activities to the architecture illustrating the process; the architecture is composed of capabilities that achieve operational activities.

Continuing the development of a standard architecting process, which will facilitate the implementation of a future towing and salvage capability, is critical to acquiring an efficient system built specifically to meet the community's needs. The success of a standard architecting process will lead to Navy-wide open architecture implementations for system development, thus reducing costs and maximizing efficiency throughout the Fleet.

THIS PAGE INTENTIONALLY LEFT BLANK

**APPENDIX A**

**SYSTEM DESCRIPTION DOCUMENT**

**FOR**

**T-ARS(X)**

---

Thursday, September 04, 2008

Prepared For:

Naval Postgraduate School, Systems Engineering Department

Prepared By:

## **T-ARS(X)**

### Allocated Functions:

- 1.0 Move through the water
- 1.1 Produce propulsive power to achieve sustained speed
- 1.2 Provide propulsive power at usable speed (rpm)
- 1.3 Transfer power to water
- 1.4 Control speed and direction of movement locally
- 1.5 Control speed and direction of movement remotely
- 10.0 Conduct pollution response
- 10.1 Provides Pollution Logistics support
- 11.0 Conduct Pollution Training
- 13.0 Conduct Diving Operations other than salvage
- 14.0 Conduct Personnel Rescue Operations
- 15.0 Conduct Underway Replenishment Operations
- 2.0 Maintain Desired Course
- 2.1 Determine if course is safe
- 2.2 Alter existing course
- 2.3 Maneuver alongside pier
- 3.0 Conduct Salvage Operations
- 3.1 Conduct Collision Repair
- 3.1 Conduct diving Operations
- 3.1.1 Conduct Underwater Inspections
- 3.1.2 Conduct Underwater Welding
- 3.2 Conduct Ocean Search and Recovery
- 3.2.1 Conduct Heavy Lift Operations
- 3.3 Retrieve vessel from beach
- 3.3 Transport/secure salvaged system or equipment
- 4.0 Conduct towing operations
- 4.1 Connect tow line to vessel
- 4.2 Position ship for towing operations
- 4.3 Tow vessel through water
- 5.0 Conduct sustained operations underway
- 5.1 Ensure habitable conditions
- 5.2 Maintain equipment in operating condition
- 5.3 Communicate information
- 5.4 Combat damage
- 5.5 Secure Condition while underway
- 5.6 Secure position while in port
- 5.7 Provide electrical power
- 5.8 Provide fuel source
- 6.0 Operate on surface of water
- 6.1 Enclose personnel and equipment
- 6.2 Support total ship weight
- 6.3 Minimize total resistance
- 7.0 Maintain Desired Position
- 7.1 Anchor ship to seafloor

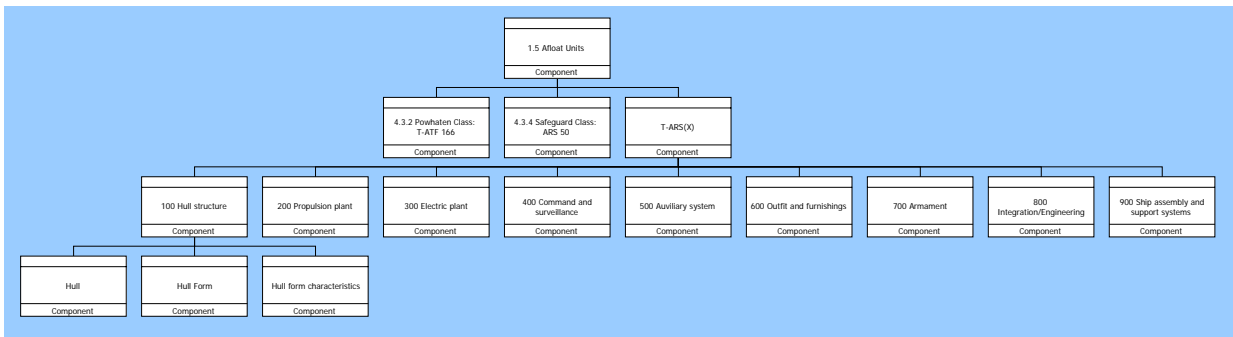
- 7.2 Control Dynamic Positioning system
- 7.3 Moor Ship to Object
- 8.0 Conduct beach retraction operations
- 9.0 Conduct Firefighting Operations

Assigned Design Constraints:

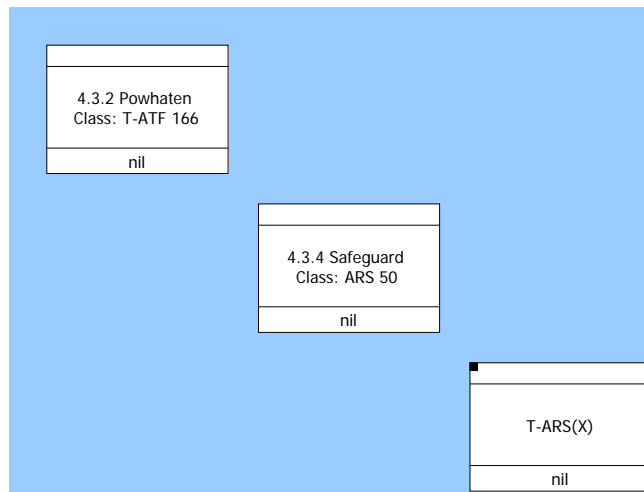
- Salvage Equipment Stowage Space
- Unobstructed Deck Space; Aft
- Unobstructed Deck Space; Fwd

Specified Performance Objectives:

- Bollard Pull
- Endurance
- Firefighting Flow Rate
- Primary Crane Lift Capacity
- Secondary Crane Lift Capacity
- Speed



**Figure 1 T-ARS(X) Physical Context**



**Figure 2 T-ARS(X) Physical Interface Context**



## 2 Originating Requirements

---

### **Bollard Pull**

Basis Of:

Function: 3.3 Retrieve vessel from beach

Function: 4.0 Conduct towing operations

Function: 4.3 Tow vessel through water

Specifies:

Component: T-ARS(X)

### **Civilian Crew**

Basis Of:

Function: 5.1 Ensure habitable conditions

Specifies:

Component: T-ARS(X)

### **Dynamic Positioning**

Basis Of:

Function: 2.3 Maneuver alongside pier

Function: 3.0 Conduct Salvage Operations

Function: 3.1 Conduct diving Operations

Function: 3.2 Conduct Ocean Search and Recovery

Function: 3.2.1 Conduct Heavy Lift Operations

Function: 3.2.2 Conduct ROV operations

Function: 4.2 Position ship for towing operations

Specifies:

Component: T-ARS(X)

### **Firefighting Flow Rate**

Basis Of:

Function: 9.0 Conduct Firefighting Operations

Specifies:

Component: T-ARS(X)

### **Ice Classification**

Basis Of:

Function: 1.0 Move through the water

Specifies:

Component: T-ARS(X)

### **Navy Personnel Accomodation**

Basis Of:

Function: 5.1 Ensure habitable conditions

## 2 Originating Requirements

---

Specifies:

Component: T-ARS(X)

### **Primary Crane Lift Capacity**

Basis Of:

Function: 3.0 Conduct Salvage Operations

Function: 3.2.1 Conduct Heavy Lift Operations

Specifies:

Component: T-ARS(X)

### **Salvage Equipment Stowage Space**

Basis Of:

Function: 3.3 Transport/secure salvaged system or equipment

Function: 6.1 Enclose personnel and equipment

Function: Maintains equipment

Function: Provides equipment/supplies

Specifies:

Component: T-ARS(X)

### **Secondary Crane Lift Capacity**

Basis Of:

Function: 3.0 Conduct Salvage Operations

Function: 3.2 Conduct Ocean Search and Recovery

Function: 3.2.1 Conduct Heavy Lift Operations

Function: 3.2.2 Conduct ROV operations

Specifies:

Component: T-ARS(X)

### **Speed**

Basis Of:

Function: 1.0 Move through the water

Function: 1.1 Produce propulsive power to achieve sustained speed

Function: 1.2 Provide propulsive power at usable speed (rpm)

Function: 1.3 Transfer power to water

Function: 1.4 Control speed and direction of movement locally

Function: 1.5 Control speed and direction of movement remotely

Specifies:

Component: T-ARS(X)

### **Unobstructed Deck Space; Aft**

Basis Of:

Function: 3.0 Conduct Salvage Operations

Function: 3.3 Transport/secure salvaged system or equipment

## 2 Originating Requirements

---

Specifies:

Component: T-ARS(X)

### **Unobstructed Deck Space; Fwd**

Basis Of:

Function: 3.0 Conduct Salvage Operations

Function: 3.3 Transport/secure salvaged system or equipment

Specifies:

Component: T-ARS(X)

## 3 Design Constraints

---

### **Salvage Equipment Stowage Space**

Constrains:

Component: T-ARS(X)

### **Unobstructed Deck Space; Aft**

Constrains:

Component: T-ARS(X)

### **Unobstructed Deck Space; Fwd**

Constrains:

Component: T-ARS(X)

# 10 Components

---

## **Bollard Pull**

Specifies:

Component: T-ARS(X)

## **Endurance**

Specifies:

Component: T-ARS(X)

Function: 1.0 Move through the water

## **Firefighting Flow Rate**

Specifies:

Component: T-ARS(X)

## **Primary Crane Lift Capacity**

Specifies:

Component: T-ARS(X)

## **Secondary Crane Lift Capacity**

Specifies:

Component: T-ARS(X)

## **Speed**

Specifies:

Component: T-ARS(X)

---

## **Part I - Hierarchical Function List**

---

1.0 Move through the water

# 10 Components

---

- 1.1 Produce propulsive power to achieve sustained speed
- 1.2 Provide propulsive power at usable speed (rpm)
- 1.3 Transfer power to water
- 1.4 Control speed and direction of movement locally
- 1.5 Control speed and direction of movement remotely
- 1.1 Produce propulsive power to achieve sustained speed
- 1.2 Provide propulsive power at usable speed (rpm)
- 1.3 Transfer power to water
- 1.4 Control speed and direction of movement locally
- 1.5 Control speed and direction of movement remotely
- 10.0 Conduct pollution response
- 10.1 Provides Pollution Logistics support
- 11.0 Conduct Pollution Training
- 13.0 Conduct Diving Operations other than salvage
- 14.0 Conduct Personnel Rescue Operations
- 15.0 Conduct Underway Replenishment Operations
- 2.0 Maintain Desired Course
  - 2.1 Determine if course is safe
  - 2.2 Alter existing course
  - 2.3 Maneuver alongside pier
- 2.1 Determine if course is safe
- 2.2 Alter existing course
- 2.3 Maneuver alongside pier
- 3.0 Conduct Salvage Operations
  - 3.1 Conduct Collision Repair
    - 3.1 Conduct diving Operations
      - 3.1.1 Conduct Underwater Inspections
      - 3.1.2 Conduct Underwater Welding
    - 3.2 Conduct Ocean Search and Recovery
      - 3.2.1 Conduct Heavy Lift Operations
      - 3.2.2 Conduct ROV operations
    - 3.3 Retrieve vessel from beach
- 3.1 Conduct Collision Repair
  - 3.1 Conduct diving Operations
    - 3.1.1 Conduct Underwater Inspections
    - 3.1.2 Conduct Underwater Welding
- 3.1 Conduct diving Operations
  - 3.1.1 Conduct Underwater Inspections
  - 3.1.2 Conduct Underwater Welding
- 3.2 Conduct Ocean Search and Recovery

# 10 Components

---

- 3.2.1 Conduct Heavy Lift Operations
- 3.2.2 Conduct ROV operations
- 3.2.1 Conduct Heavy Lift Operations
- 3.3 Retrieve vessel from beach
- 3.3 Transport/secure salvaged system or equipment
- 4.0 Conduct towing operations
  - 4.1 Connect tow line to vessel
  - 4.2 Position ship for towing operations
  - 4.3 Tow vessel through water
- 4.1 Connect tow line to vessel
- 4.2 Position ship for towing operations
- 4.3 Tow vessel through water
- 5.0 Conduct sustained operations underway
  - 5.1 Ensure habitable conditions
  - 5.2 Maintain equipment in operating condition
  - 5.3 Communicate information
  - 5.4 Combat damage
  - 5.5 Secure Condition while underway
  - 5.6 Secure position while in port
  - 5.7 Provide electrical power
  - 5.8 Provide fuel source
- 5.1 Ensure habitable conditions
- 5.2 Maintain equipment in operating condition
- 5.3 Communicate information
- 5.4 Combat damage
- 5.5 Secure Condition while underway
- 5.6 Secure position while in port
- 5.7 Provide electrical power
- 5.8 Provide fuel source
- 6.0 Operate on surface of water
  - 6.1 Enclose personnel and equipment
  - 6.2 Support total ship weight
  - 6.3 Minimize total resistance
- 6.1 Enclose personnel and equipment
- 6.2 Support total ship weight
- 6.3 Minimize total resistance
- 7.0 Maintain Desired Position
  - 7.1 Anchor ship to seafloor
  - 7.2 Control Dynamic Positioning system
  - 7.3 Moor Ship to Object

# 10 Components

- 7.1 Anchor ship to seafloor
- 7.2 Control Dynamic Positioning system
- 7.3 Moor Ship to Object
- 8.0 Conduct beach retraction operations
- 9.0 Conduct Firefighting Operations

---

## Part II - Behavior Model

---

### 1.0 Move through the water

Allocated To:

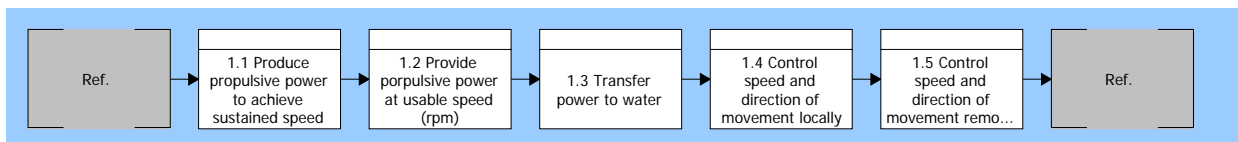
- 1.5 Afloat Units
- 4.3.2 Powhatan Class: T-ATF 166
- 4.3.4 Safeguard Class: ARS 50
- Bow Thruster
- Controllable Reversible Pitch Propeller
- Diver Support Boat
- Fuel system
- Oil Transfer Pumps and Hoses
- OOC2 Salvage and Towing Assets
- OOC2 Salvage Assets
- Propulsion System
- T-ARS(X)

Specified By Requirements:

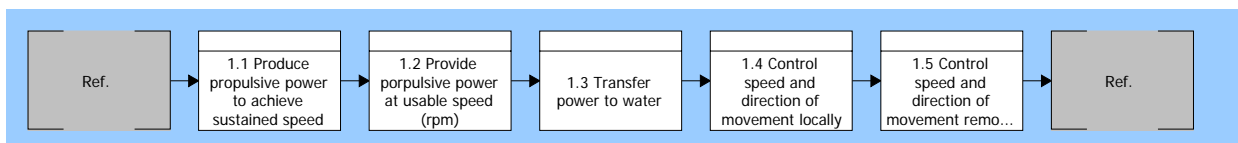
Endurance

Based On:

Ice Classification  
Speed



**Figure 3 1.0 Move through the water Enhanced FFBD**

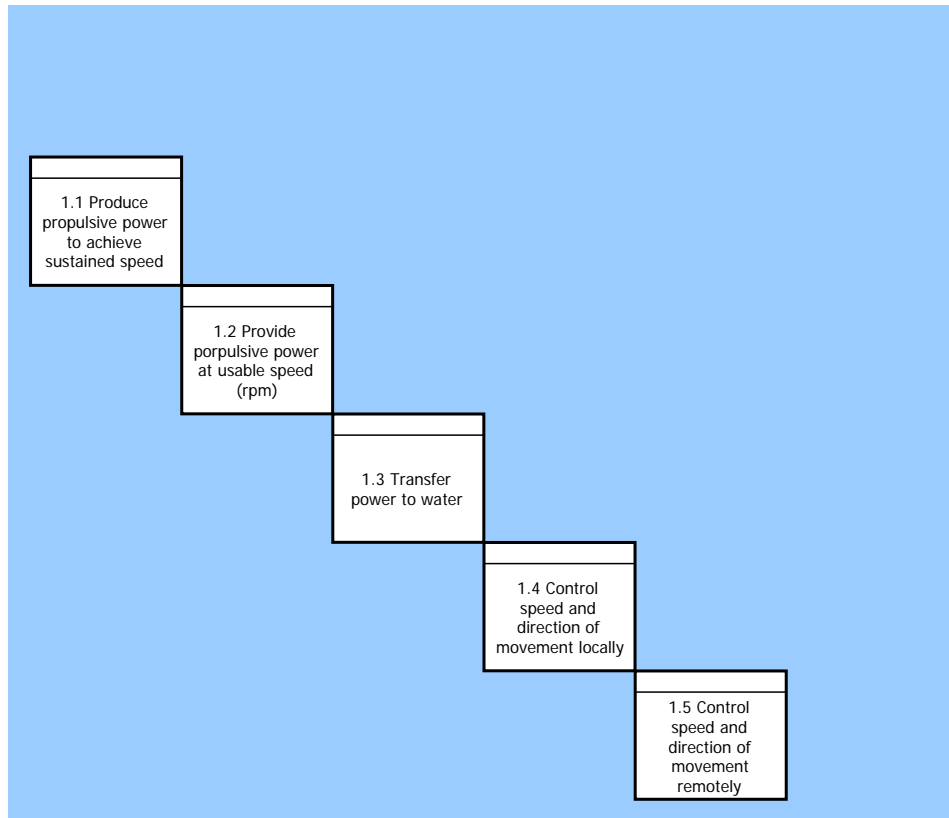


**Figure 4 1.0 Move through the water FFBD**



# 10 Components

---



**Figure 5 1.0 Move through the water N2 Diagram**

# 10 Components

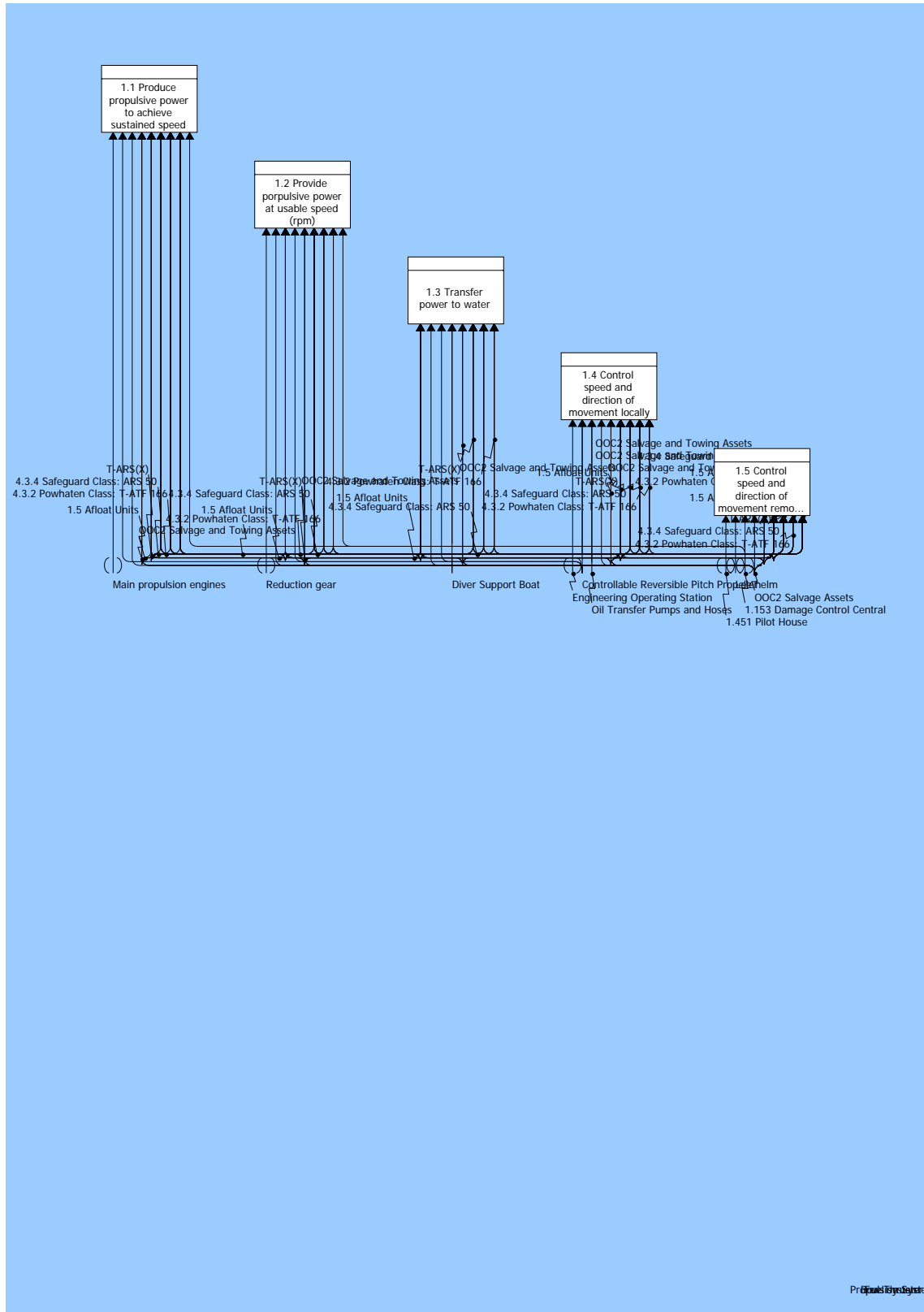


Figure 6 1.0 Move through the water IDEF0 Diagram

# 10 Components

---

## 1.1 Produce propulsive power to achieve sustained speed

Allocated To:

- 1.153 Damage Control Central
- 1.5 Afloat Units
- 4.3.2 Powhatan Class: T-ATF 166
- 4.3.4 Safeguard Class: ARS 50
- Controllable Reversible Pitch Propeller
- Main propulsion engines
- OOC2 Salvage and Towing Assets
- OOC2 Salvage Assets
- T-ARS(X)

Based On:

Speed

## 1.2 Provide propulsive power at usable speed (rpm)

Allocated To:

- 1.153 Damage Control Central
- 1.5 Afloat Units
- 4.3.2 Powhatan Class: T-ATF 166
- 4.3.4 Safeguard Class: ARS 50
- Controllable Reversible Pitch Propeller
- OOC2 Salvage and Towing Assets
- OOC2 Salvage Assets
- Reduction gear
- T-ARS(X)

Based On:

Speed

## 1.3 Transfer power to water

Allocated To:

- 1.5 Afloat Units
- 4.3.2 Powhatan Class: T-ATF 166
- 4.3.4 Safeguard Class: ARS 50
- Controllable Reversible Pitch Propeller
- Diver Support Boat
- OOC2 Salvage and Towing Assets
- OOC2 Salvage Assets
- T-ARS(X)

Based On:

Speed

## 1.4 Control speed and direction of movement locally

Allocated To:

- 1.5 Afloat Units
- 4.3.2 Powhatan Class: T-ATF 166

# 10 Components

---

4.3.4 Safeguard Class: ARS 50  
Controllable Reversible Pitch Propeller  
Engineering Operating Station  
Oil Transfer Pumps and Hoses  
OOC2 Salvage and Towing Assets  
OOC2 Salvage Assets  
T-ARS(X)

Based On:  
Speed

## 1.5 Control speed and direction of movement remotely

Allocated To:  
1.153 Damage Control Central  
1.451 Pilot House  
1.5 Afloat Units  
4.3.2 Powhatan Class: T-ATF 166  
4.3.4 Safeguard Class: ARS 50  
Lee helm  
OOC2 Salvage and Towing Assets  
OOC2 Salvage Assets  
T-ARS(X)

Based On:  
Speed

## 10.0 Conduct pollution response

Allocated To:  
1.153 Damage Control Central  
1.5 Afloat Units  
4.3.2 Powhatan Class: T-ATF 166  
4.3.4 Safeguard Class: ARS 50  
Commercial Transport System  
Damage control systems and equipment  
Diver Support Boat  
Floating Storage Bladders  
Military Cargo Transport System  
OOC1 Logistics  
OOC2 Salvage and Towing Assets  
OOC25 Pollution Logistics Support  
OOC25 Pollution Planning and Compliance  
OOC25 Pollution Research and Development  
OOC25 Pollution Response  
Open Ocean Skimmers  
Pollution Containment Booms  
SEA OOC25 Pollution  
Ship Service Support for Host Deployment of Self-contained Oil Spill Suite  
Small Skimmers  
Sorbent Materials

# 10 Components

---

T-ARS(X)

## 10.1 Provides Pollution Logistics support

Allocated To:

- Commercial Transport System
- Military Cargo Transport System
- OO1 Logistics
- OO2 Salvage and Towing Assets
- OO25 Pollution Logistics Support
- OO25 Pollution Response
- SEA OO25 Pollution
- Ship Service Support for Host Deployment of Self-contained Oil Spill Suite
- T-ARS(X)

## 11.0 Conduct Pollution Training

Allocated To:

- 1.125 Consolidated Divers Unit
- 1.5 Afloat Units
- 4.3.2 Powhatan Class: T-ATF 166
- 4.3.4 Safeguard Class: ARS 50
- OO25 Pollution Planning and Compliance
- OO25 Pollution Publications
- OO25 Pollution Research and Development
- OO25 Pollution Response
- OO25 Pollution Training
- SEA OO25 Pollution
- T-ARS(X)

## 13.0 Conduct Diving Operations other than salvage

Allocated To:

- 1.125 Consolidated Divers Unit
- 1.5 Afloat Units
- 4.3.4 Safeguard Class: ARS 50
- Communications equipment
- Deck Lighting
- Diver Davits
- Diver Deployment Support Stations
- Diver Life Support System (DLSS)
- Diver Support Boat
- OO2 Salvage and Towing Assets
- OO2 Salvage Assets
- Portable Davits
- T-ARS(X)

## 14.0 Conduct Personnel Rescue Operations

Allocated To:

- 1.125 Consolidated Divers Unit

# 10 Components

---

1.451 Pilot House  
1.5 Afloat Units  
2 1/4" Wire  
4.3.4 Safeguard Class: ARS 50  
Communications equipment  
CSNDL Recompressor Chamber  
Deck Lighting  
Diver Support Boat  
Firefighting Monitors  
Fuel system  
OOC2 Salvage and Towing Assets  
OOC2 Salvage Assets  
Portable Firefighting Equipment  
T-ARS(X)

## 15.0 Conduct Underway Replenishment Operations

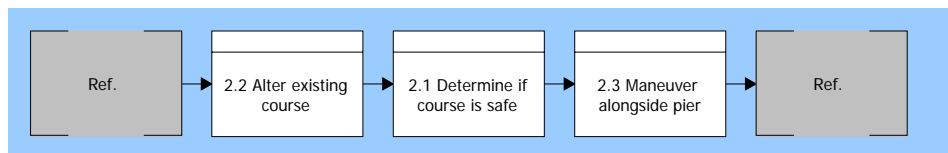
Allocated To:

1.153 Damage Control Central  
1.5 Afloat Units  
4.3.2 Powhatan Class: T-ATF 166  
4.3.4 Safeguard Class: ARS 50  
Communications equipment  
Deck Lighting  
Fuel system  
OOC2 Salvage and Towing Assets  
OOC2 Salvage Assets  
Replenishment Stations  
T-ARS(X)

## 2.0 Maintain Desired Course

Allocated To:

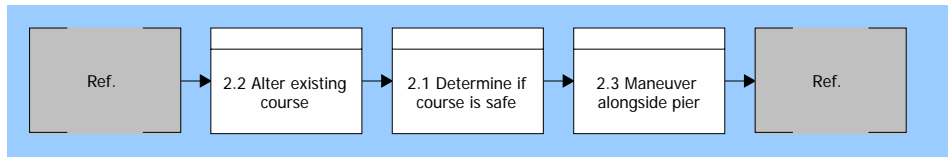
1.451 Pilot House  
1.5 Afloat Units  
4.3.2 Powhatan Class: T-ATF 166  
4.3.4 Safeguard Class: ARS 50  
Diver Support Boat  
Fuel system  
Maneuvering and Control System  
OOC2 Salvage and Towing Assets  
OOC2 Salvage Assets  
T-ARS(X)



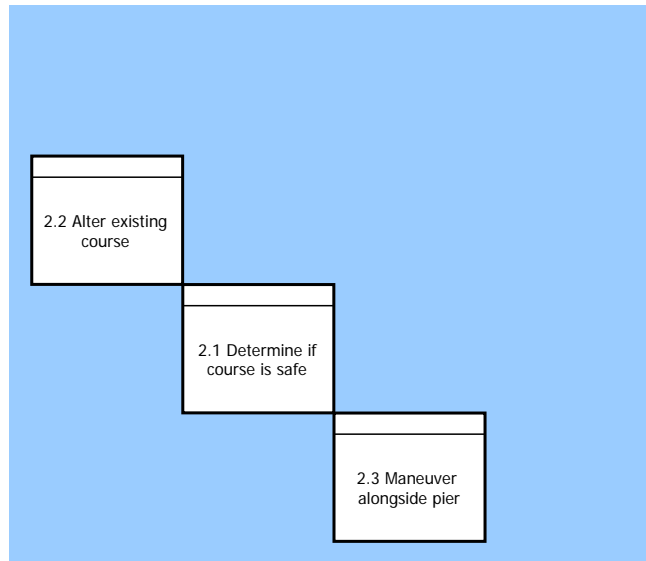
**Figure 7 2.0 Maintain Desired Course Enhanced FFBD**

# 10 Components

---



**Figure 8 2.0 Maintain Desired Course FFBD**



**Figure 9 2.0 Maintain Desired Course N2 Diagram**





# 10 Components

---

## 2.1 Determine if course is safe

Allocated To:

- 1.451 Pilot House
- 1.5 Afloat Units
- 4.3.2 Powhatan Class: T-ATF 166
- 4.3.4 Safeguard Class: ARS 50
- Navigation equipment
- OOC2 Salvage and Towing Assets
- OOC2 Salvage Assets
- T-ARS(X)

## 2.2 Alter existing course

Allocated To:

- 1.451 Pilot House
- 1.5 Afloat Units
- 4.3.2 Powhatan Class: T-ATF 166
- 4.3.4 Safeguard Class: ARS 50
- Bow Thruster
- OOC2 Salvage and Towing Assets
- OOC2 Salvage Assets
- Rudder
- T-ARS(X)

## 2.3 Maneuver alongside pier

Allocated To:

- 1.451 Pilot House
- 1.5 Afloat Units
- 4.3.2 Powhatan Class: T-ATF 166
- 4.3.4 Safeguard Class: ARS 50
- Bow thrusters/APU
- Bow/Stern Roller System
- Controllable Reversible Pitch Propeller
- Diver Support Boat
- Fuel system
- OOC2 Salvage and Towing Assets
- OOC2 Salvage Assets
- T-ARS(X)

Based On:

- Dynamic Positioning

## 3.0 Conduct Salvage Operations

Allocated To:

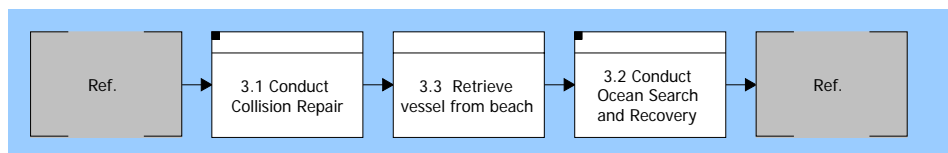
- 1.125 Consolidated Divers Unit
- 1.5 Afloat Units
- 2 1/4" Wire
- 4.3.4 Safeguard Class: ARS 50

# 10 Components

9.036 Crane  
Communications equipment  
Deck Fastener System  
Deck Lighting  
Deep Drone 7200 ROV  
Diver Davits  
Diver Deployment Support Stations  
Diver Life Support System (DLSS)  
Diver Support Boat  
Fabrication Space  
Hydraulic Power Packs  
Ikelite Housing and JVC Camcorder  
Lateral Control Winch  
Main Deck Remote Control Station  
MINIROVs  
OOC2 Ocean Search and Recovery Assets  
OOC2 Salvage and Towing Assets  
OOC2 Salvage Assets  
OOC2 Search and Recovery Assets  
Orion Search System  
Portable Bullwarks  
Portable Generators  
Rope Transport Tray  
Secondary Crane  
Shallow Water Intermediate Search System (SWISS)  
Shark Jaws  
Ship Service Support for Portable DLSS Air Compressor  
Ship Service Support for SAT\_FADS  
Ship Service Support for SRDRS  
T-ARS(X)  
Unobstructed Deck Space; Aft  
Unobstructed Deck Space; Fwd  
Vacuum Recovery System

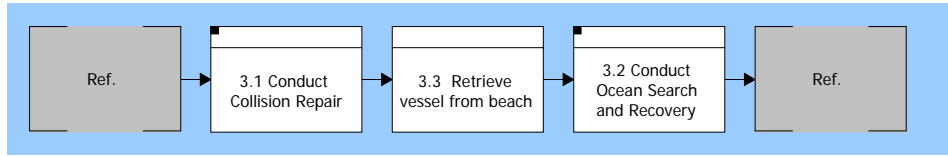
Based On:

Dynamic Positioning  
Primary Crane Lift Capacity  
Secondary Crane Lift Capacity  
Unobstructed Deck Space; Aft  
Unobstructed Deck Space; Fwd

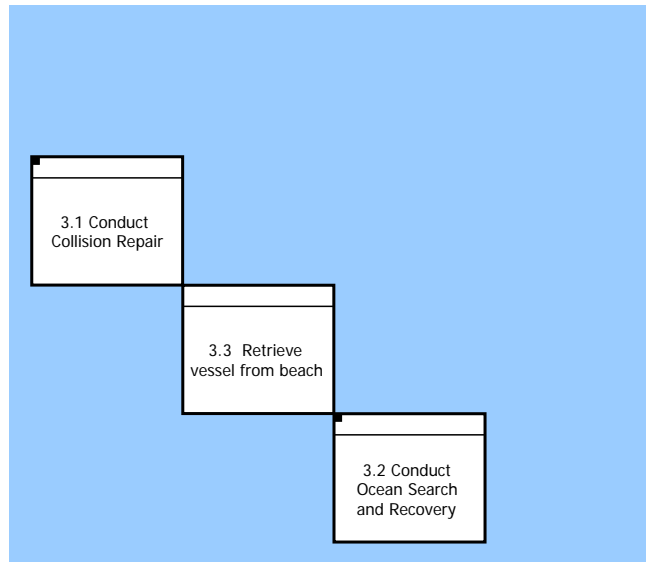


**Figure 11 3.0 Conduct Salvage Operations Enhanced FFBD**

# 10 Components



**Figure 12 3.0 Conduct Salvage Operations FFBD**



**Figure 13 3.0 Conduct Salvage Operations N2 Diagram**

# 10 Components

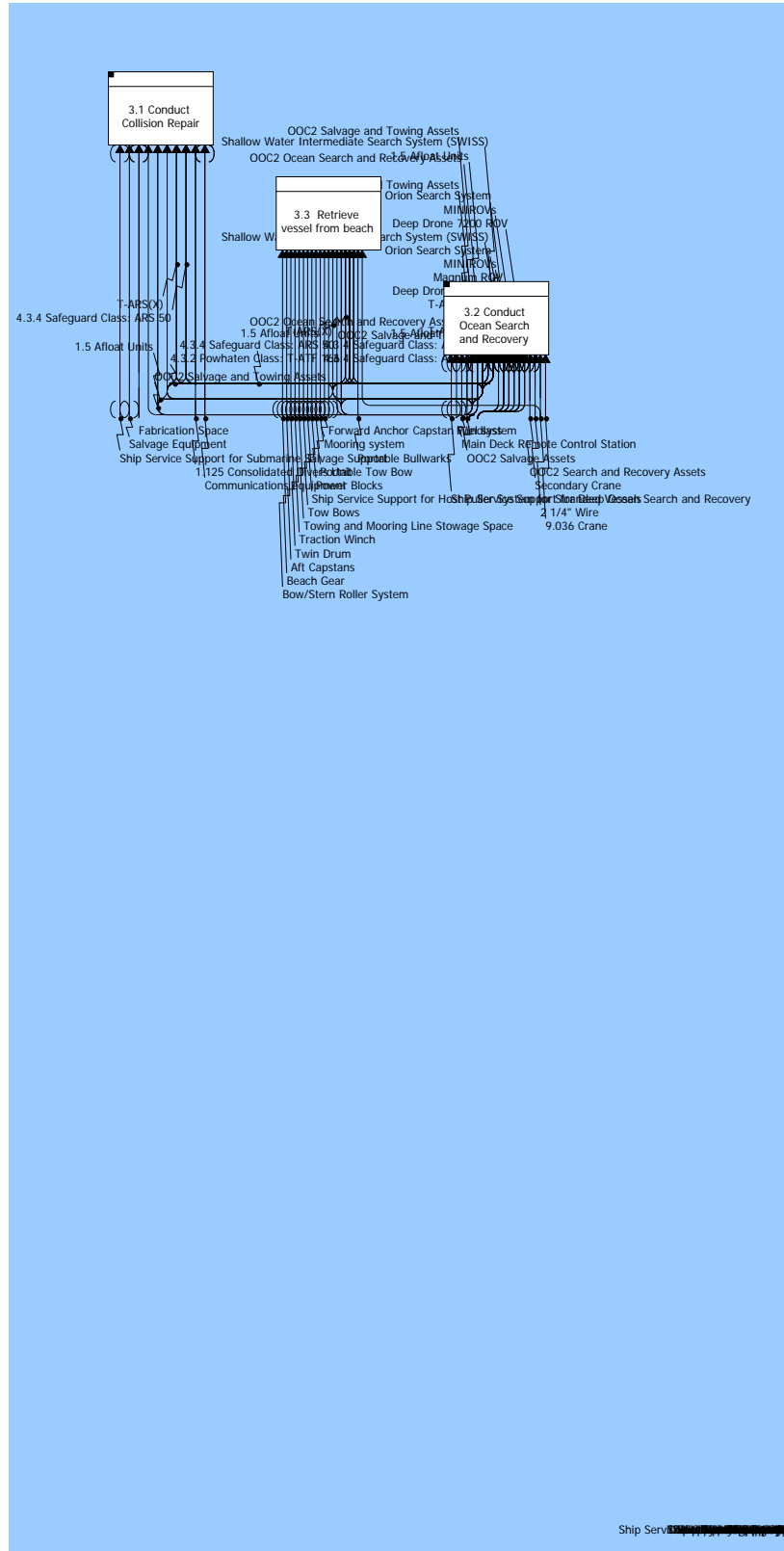


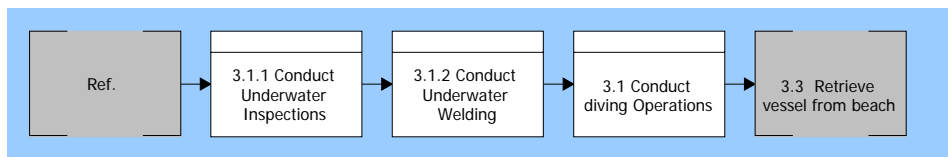
Figure 14 3.0 Conduct Salvage Operations IDEF0 Diagram

# 10 Components

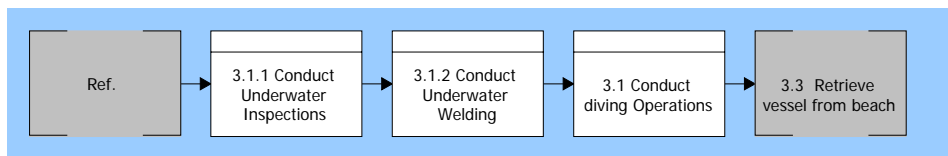
## 3.1 Conduct Collision Repair

Allocated To:

- 1.125 Consolidated Divers Unit
- 1.5 Afloat Units
- 4.3.4 Safeguard Class: ARS 50
- Communications equipment
- Fabrication Space
- OOC2 Salvage and Towing Assets
- OOC2 Salvage Assets
- Salvage Equipment
- Ship Service Support for Submarine Salvage Support
- T-ARS(X)

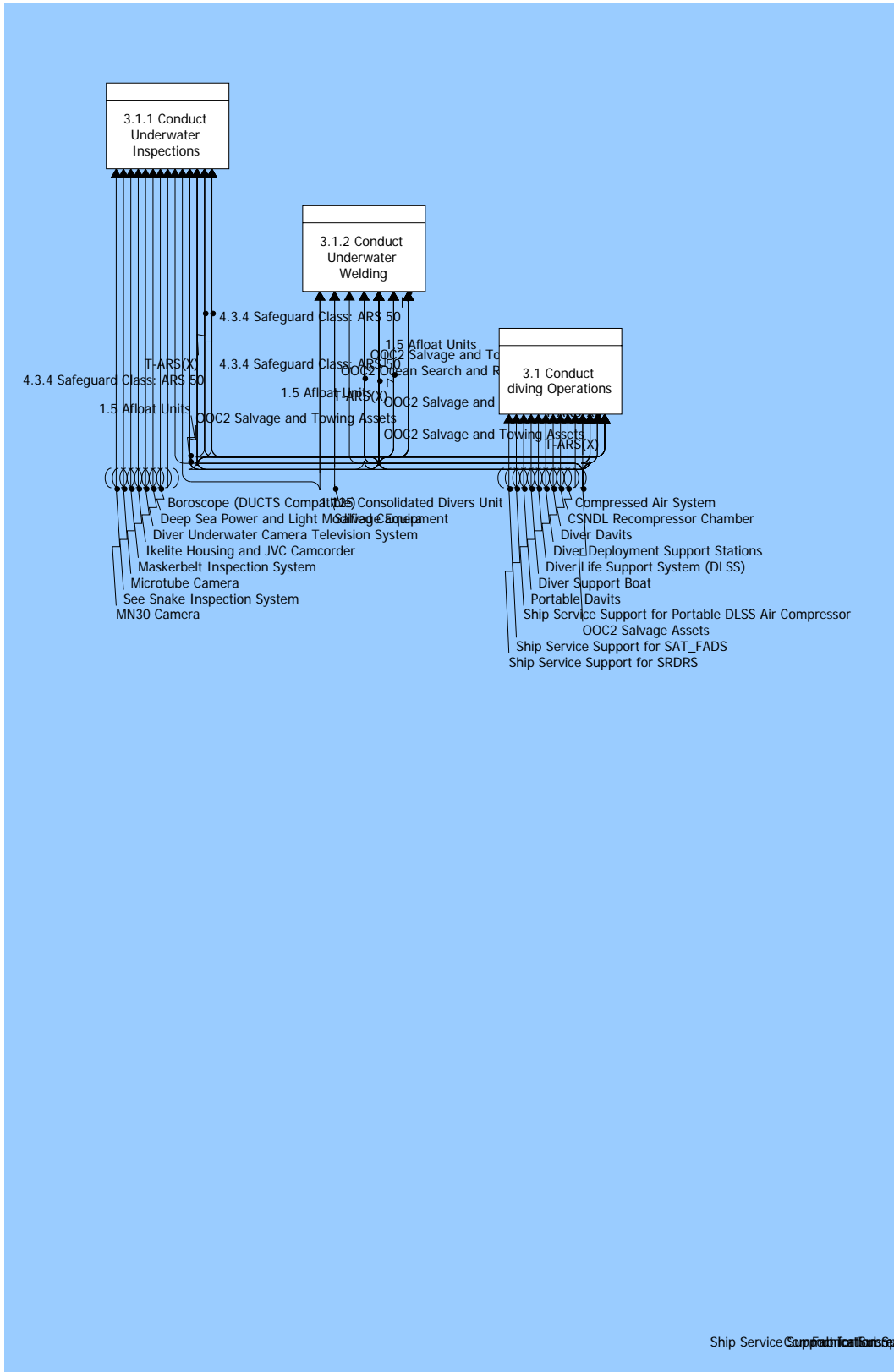


**Figure 15 3.1 Conduct Collision Repair Enhanced FFBD**



**Figure 16 3.1 Conduct Collision Repair FFBD**

# 10 Components



# 10 Components

---

**Figure 18 3.1 Conduct Collision Repair IDEF0 Diagram**

## **3.1 Conduct diving Operations**

Allocated To:

- Compressed Air System
- CSNDL Recompressor Chamber
- Diver Davits
- Diver Deployment Support Stations
- Diver Life Support System (DLSS)
- Diver Support Boat
- OOC2 Ocean Search and Recovery Assets
- OOC2 Salvage and Towing Assets
- OOC2 Salvage Assets
- Portable Davits
- Ship Service Support for Portable DLSS Air Compressor
- Ship Service Support for SAT\_FADS
- Ship Service Support for SRDRS
- T-ARS(X)

Based On:

- Dynamic Positioning

### **3.1.1 Conduct Underwater Inspections**

Allocated To:

- 1.125 Consolidated Divers Unit
- 1.5 Afloat Units
- 4.3.4 Safeguard Class: ARS 50
- Boroscope (DUCTS Compatible)
- Deep Sea Power and Light Modified Camera
- Diver Underwater Camera Television System
- Ikelite Housing and JVC Camcorder
- Maskerbelt Inspection System
- Microtube Camera
- MN30 Camera
- OOC2 Salvage and Towing Assets
- OOC2 Salvage Assets
- See Snake Inspection System
- T-ARS(X)

### **3.1.2 Conduct Underwater Welding**

Allocated To:

- 1.125 Consolidated Divers Unit
- 1.5 Afloat Units
- 4.3.4 Safeguard Class: ARS 50
- OOC2 Salvage and Towing Assets
- OOC2 Salvage Assets
- Salvage Equipment
- T-ARS(X)

# 10 Components

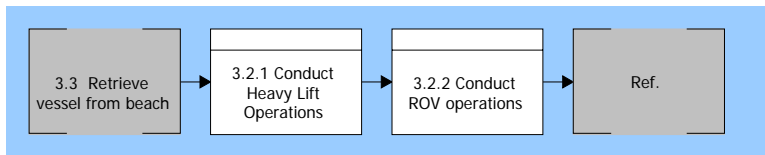
## 3.2 Conduct Ocean Search and Recovery

Allocated To:

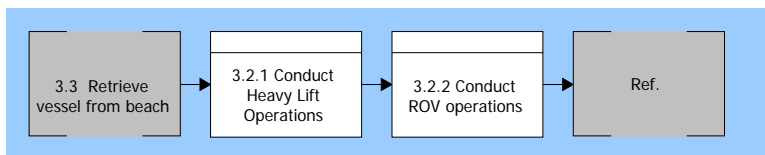
- 1.5 Afloat Units
- 2 1/4" Wire
- 4.3.4 Safeguard Class: ARS 50
- 9.036 Crane
- Curv III ROV
- Deep Drone 7200 ROV
- Fuel system
- Magnum ROV
- Main Deck Remote Control Station
- MINIROVs
- OOC2 Ocean Search and Recovery Assets
- OOC2 Salvage and Towing Assets
- OOC2 Salvage Assets
- OOC2 Search and Recovery Assets
- Orion Search System
- Secondary Crane
- Shallow Water Intermediate Search System (SWISS)
- Ship Service Support for Deep Ocean Search and Recovery
- T-ARS(X)

Based On:

- Dynamic Positioning
- Secondary Crane Lift Capacity



**Figure 19 3.2 Conduct Ocean Search and Recovery Enhanced FFBD**



**Figure 20 3.2 Conduct Ocean Search and Recovery FFBD**





# 10 Components

---

## 3.2.1 Conduct Heavy Lift Operations

Allocated To:

- 1.5 Afloat Units
- 2 1/4" Wire
- 4.3.4 Safeguard Class: ARS 50
- 9.036 Crane
- Deck Fastener System
- Deck Lighting
- OOC2 Salvage and Towing Assets
- OOC2 Salvage Assets
- Secondary Crane
- T-ARS(X)
- Unobstructed Deck Space; Aft
- Unobstructed Deck Space; Fwd

Based On:

- Dynamic Positioning
- Primary Crane Lift Capacity
- Secondary Crane Lift Capacity

## 3.2.2 Conduct ROV operations

Based On:

- Dynamic Positioning
- Secondary Crane Lift Capacity

## 3.3 Retrieve vessel from beach

Allocated To:

- 1.5 Afloat Units
- 2 1/4" Wire
- 4.3.2 Powhatan Class: T-ATF 166
- 4.3.4 Safeguard Class: ARS 50
- Aft Capstans
- Beach Gear
- Bow/Stern Roller System
- Forward Anchor Capstan Windlass
- Mooring system
- OOC2 Salvage and Towing Assets
- OOC2 Salvage Assets
- Portable Bullwarks
- Portable Tow Bow
- Power Blocks
- Ship Service Support for Host Puller System for Stranded Vessels
- T-ARS(X)
- Tow Bows
- Towing and Mooring Line Stowage Space
- Traction Winch
- Twin Drum

# 10 Components

Based On:  
Bollard Pull

## 3.3 Transport/secure salvaged system or equipment

Allocated To:  
Deck Fastener System  
OOC2 Salvage and Towing Assets  
OOC2 Salvage Assets  
T-ARS(X)  
Unobstructed Deck Space; Aft  
Unobstructed Deck Space; Fwd

Based On:  
Salvage Equipment Stowage Space  
Unobstructed Deck Space; Aft  
Unobstructed Deck Space; Fwd

## 4.0 Conduct towing operations

Allocated To:  
1.451 Pilot House  
1.5 Afloat Units  
4.3.2 Powhatan Class: T-ATF 166  
Auto-tow pins  
Bow Thruster  
Communications equipment  
Controllable Reversible Pitch Propeller  
Deck Lighting  
Fuel system  
Hydraulic Power Packs  
OOC2 Salvage and Towing Assets  
Portable Bullwarks  
Portable Tow Bow  
Rope Transport Tray  
T-ARS(X)  
Tow Fairleads

Based On:  
Bollard Pull

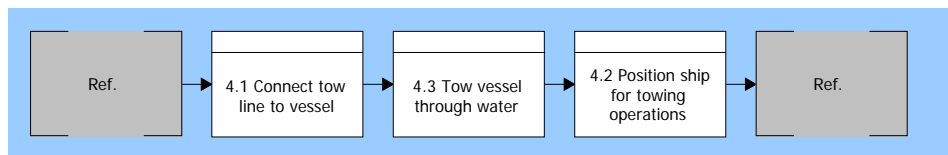
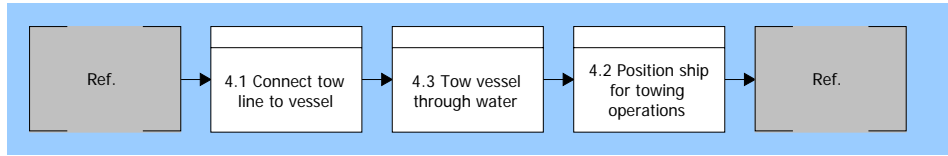
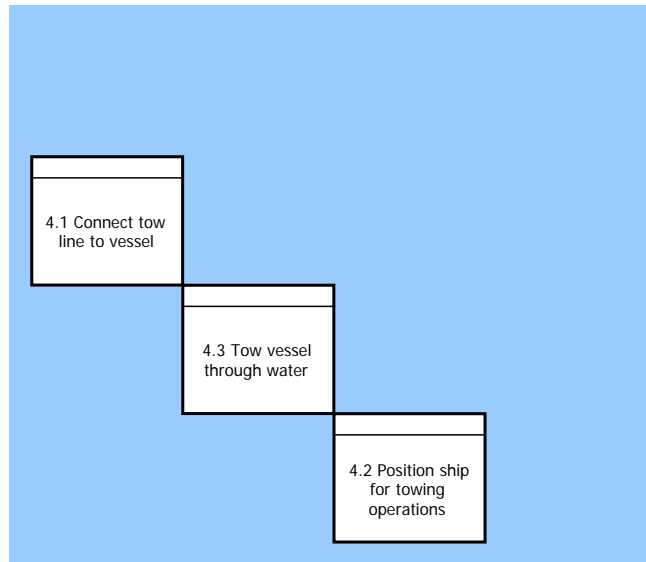


Figure 23 4.0 Conduct towing operations Enhanced FFBD

# 10 Components



**Figure 24 4.0 Conduct towing operations FFBD**



**Figure 25 4.0 Conduct towing operations N2 Diagram**

# 10 Components

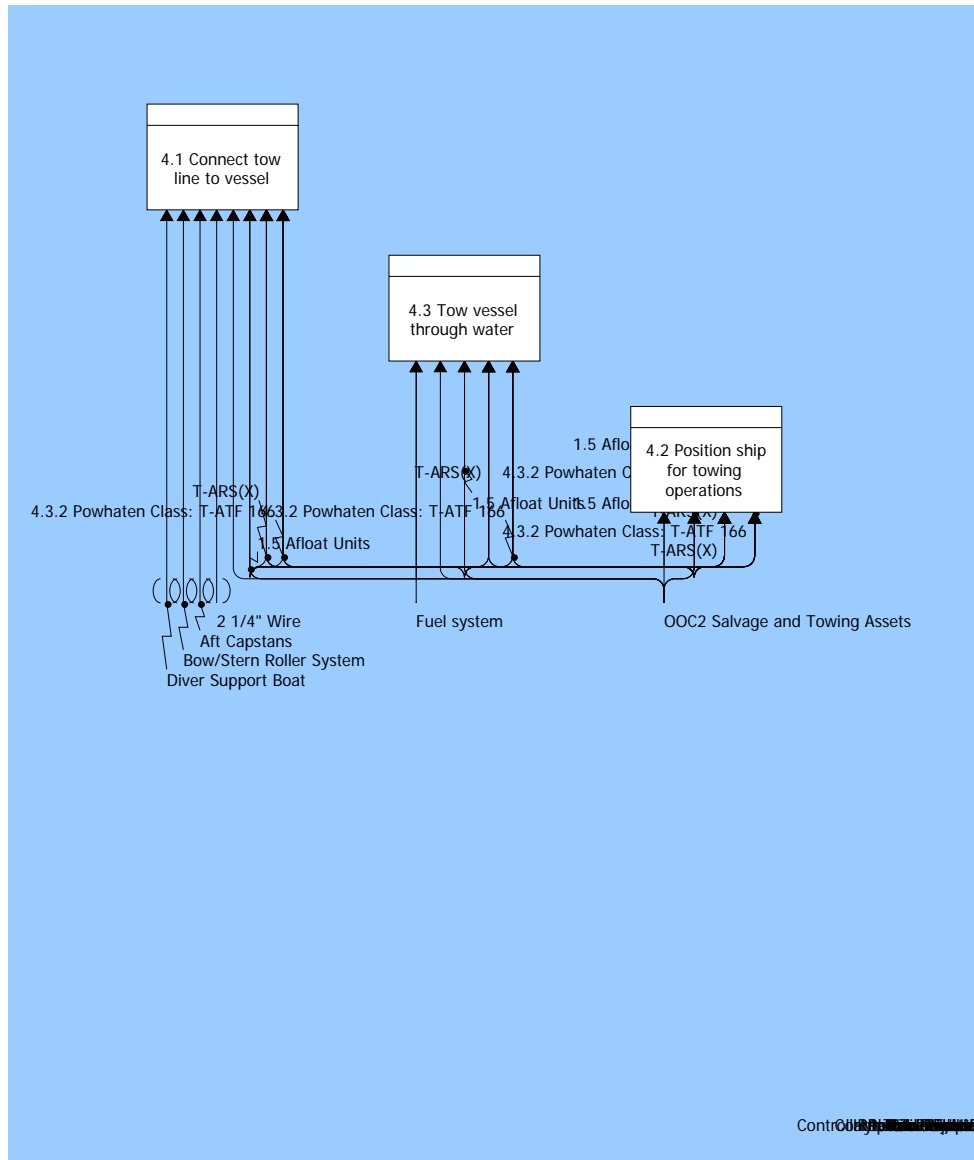


Figure 26 4.0 Conduct towing operations IDEF0 Diagram

## 4.1 Connect tow line to vessel

Allocated To:

- 1.5 Afloat Units
- 2 1/4" Wire
- 4.3.2 Powhatan Class: T-ATF 166
- Aft Capstans
- Bow/Stern Roller System
- Diver Support Boat
- OOC2 Salvage and Towing Assets
- T-ARS(X)

# 10 Components

## 4.2 Position ship for towing operations

Allocated To:

- 1.5 Afloat Units
- 4.3.2 Powhatan Class: T-ATF 166
- OOC2 Salvage and Towing Assets
- T-ARS(X)

Based On:

Dynamic Positioning

## 4.3 Tow vessel through water

Allocated To:

- 1.5 Afloat Units
- 4.3.2 Powhatan Class: T-ATF 166
- Fuel system
- OOC2 Salvage and Towing Assets
- T-ARS(X)

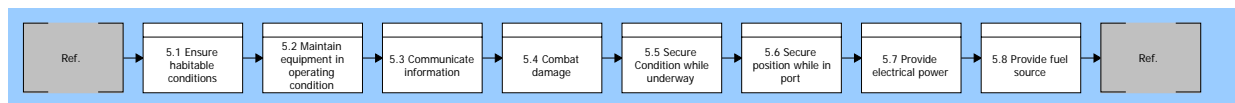
Based On:

Bollard Pull

## 5.0 Conduct sustained operations underway

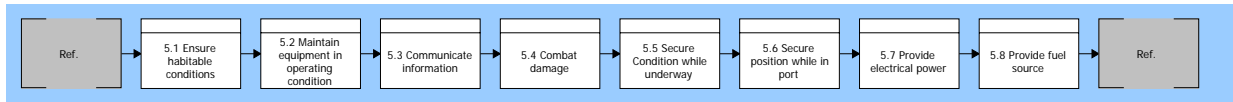
Allocated To:

- 1.153 Damage Control Central
- 1.5 Afloat Units
- 4.3.2 Powhatan Class: T-ATF 166
- 4.3.4 Safeguard Class: ARS 50
- Communications equipment
- Controllable Reversible Pitch Propeller
- Deck Lighting
- Diver Support Boat
- Electrical system
- Fuel system
- OOC2 Salvage and Towing Assets
- OOC2 Salvage Assets
- Support/Auxiliary Systems
- T-ARS(X)

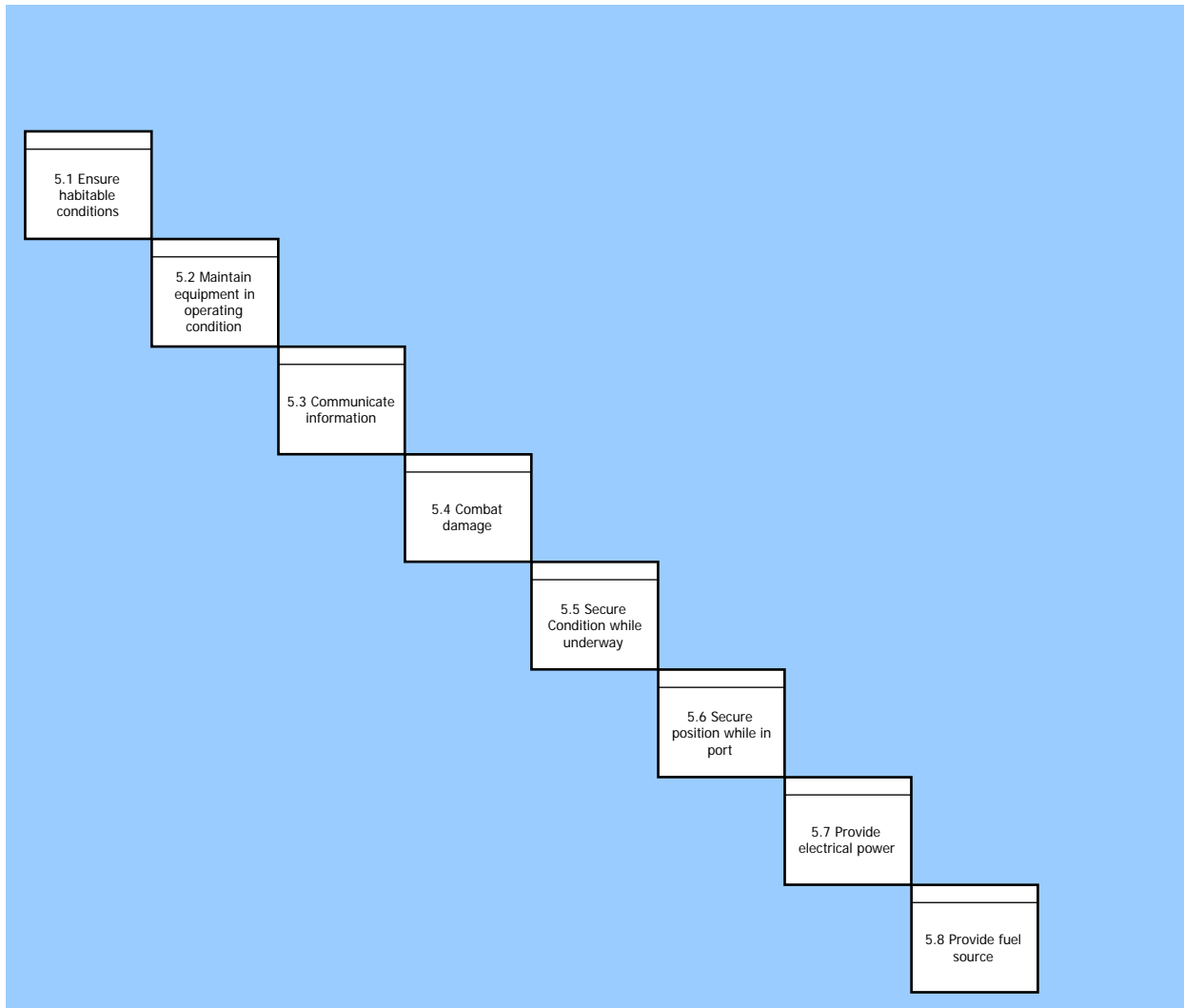


**Figure 27 5.0 Conduct sustained operations underway Enhanced FFBD**

# 10 Components



**Figure 28 5.0 Conduct sustained operations underway FFBD**



**Figure 29 5.0 Conduct sustained operations underway N2 Diagram**

# 10 Components

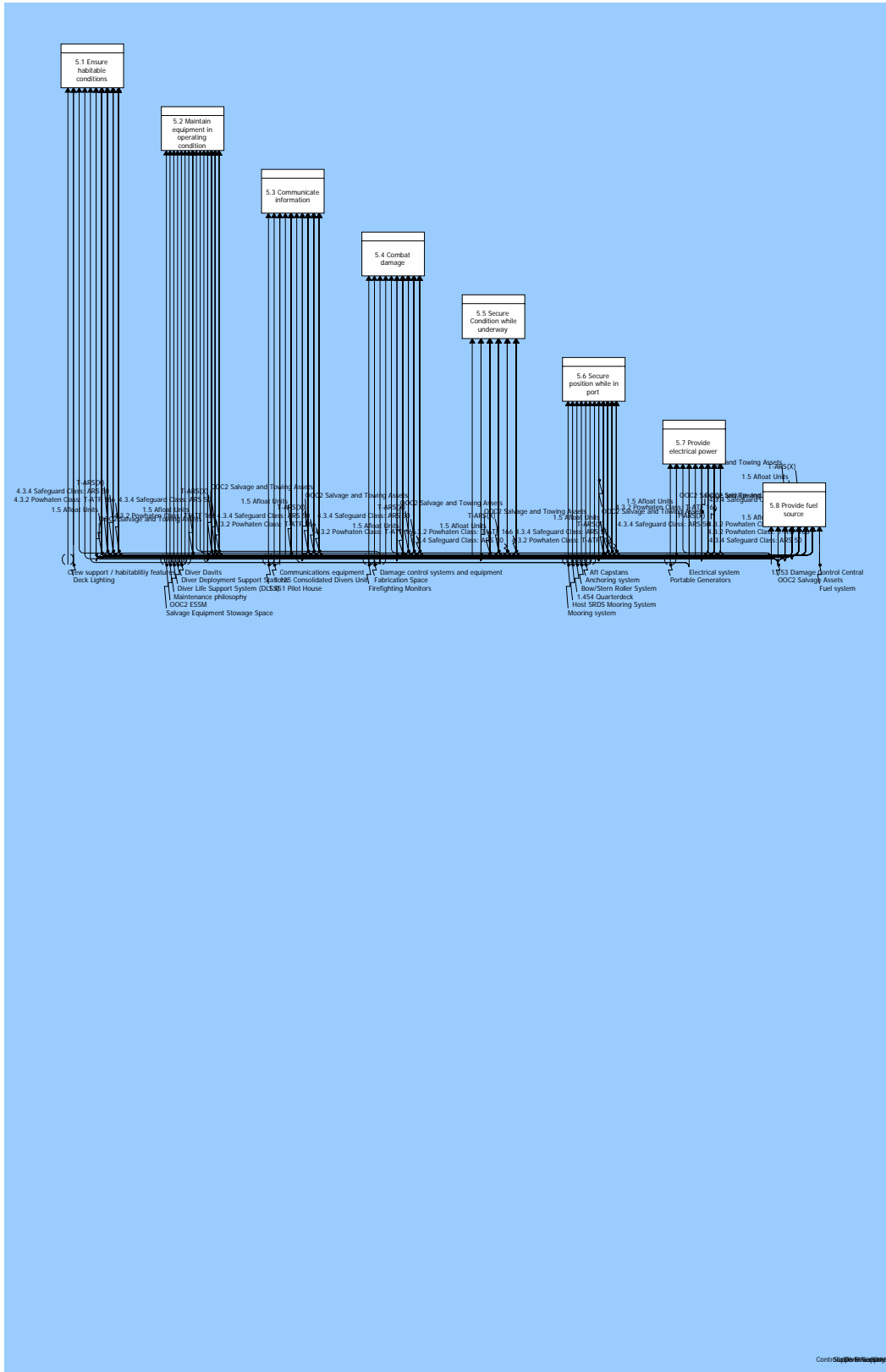


Figure 30 5.0 Conduct sustained operations underway IDEF0 Diagram



# 10 Components

---

## 5.1 Ensure habitable conditions

Allocated To:

- 1.153 Damage Control Central
- 1.5 Afloat Units
- 4.3.2 Powhatan Class: T-ATF 166
- 4.3.4 Safeguard Class: ARS 50
- Crew support / habitability features
- Deck Lighting
- Electrical system
- OOC2 Salvage and Towing Assets
- OOC2 Salvage Assets
- T-ARS(X)

Based On:

- Civilian Crew
- Navy Personnel Accommodation

## 5.2 Maintain equipment in operating condition

Allocated To:

- 1.153 Damage Control Central
- 1.5 Afloat Units
- 4.3.2 Powhatan Class: T-ATF 166
- 4.3.4 Safeguard Class: ARS 50
- Damage control systems and equipment
- Diver Davits
- Diver Deployment Support Stations
- Diver Life Support System (DLSS)
- Electrical system
- Maintenance philosophy
- OOC2 ESSM
- OOC2 Salvage and Towing Assets
- OOC2 Salvage Assets
- Salvage Equipment Stowage Space
- T-ARS(X)

## 5.3 Communicate information

Allocated To:

- 1.125 Consolidated Divers Unit
- 1.451 Pilot House
- 1.5 Afloat Units
- 4.3.2 Powhatan Class: T-ATF 166
- 4.3.4 Safeguard Class: ARS 50
- Communications equipment
- Electrical system
- OOC2 Salvage and Towing Assets
- OOC2 Salvage Assets
- T-ARS(X)

# 10 Components

---

## 5.4 Combat damage

Allocated To:

- 1.153 Damage Control Central
- 1.5 Afloat Units
- 4.3.2 Powhatan Class: T-ATF 166
- 4.3.4 Safeguard Class: ARS 50
- Damage control systems and equipment
- Fabrication Space
- Firefighting Monitors
- OOC2 Salvage and Towing Assets
- OOC2 Salvage Assets
- T-ARS(X)

## 5.5 Secure Condition while underway

Allocated To:

- 1.5 Afloat Units
- 4.3.2 Powhatan Class: T-ATF 166
- 4.3.4 Safeguard Class: ARS 50
- OOC2 Salvage and Towing Assets
- OOC2 Salvage Assets
- T-ARS(X)

## 5.6 Secure position while in port

Allocated To:

- 1.454 Quarterdeck
- 1.5 Afloat Units
- 4.3.2 Powhatan Class: T-ATF 166
- 4.3.4 Safeguard Class: ARS 50
- Aft Capstans
- Anchoring system
- Bow/Stern Roller System
- Host SRDS Mooring System
- Mooring system
- OOC2 Salvage and Towing Assets
- OOC2 Salvage Assets
- T-ARS(X)

## 5.7 Provide electrical power

Allocated To:

- 1.153 Damage Control Central
- 1.5 Afloat Units
- 4.3.2 Powhatan Class: T-ATF 166
- 4.3.4 Safeguard Class: ARS 50
- Electrical system
- OOC2 Salvage and Towing Assets
- OOC2 Salvage Assets
- Portable Generators

# 10 Components

T-ARS(X)

## 5.8 Provide fuel source

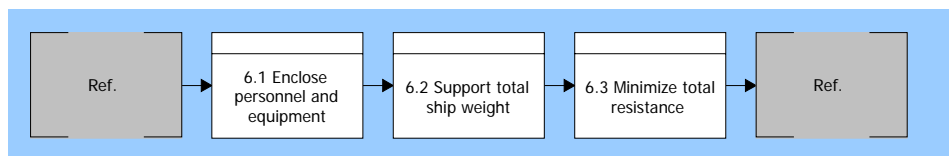
Allocated To:

- 1.153 Damage Control Central
- 1.5 Afloat Units
- 4.3.2 Powhatan Class: T-ATF 166
- 4.3.4 Safeguard Class: ARS 50
- Fuel system
- OOC2 Salvage and Towing Assets
- OOC2 Salvage Assets
- T-ARS(X)

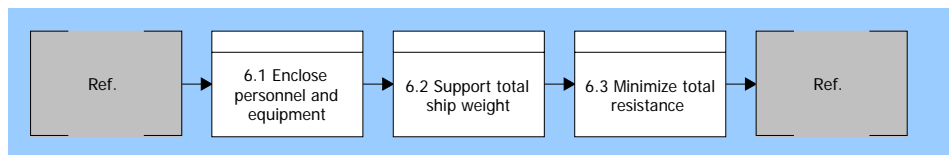
## 6.0 Operate on surface of water

Allocated To:

- 1.451 Pilot House
- 1.5 Afloat Units
- 4.3.2 Powhatan Class: T-ATF 166
- 4.3.4 Safeguard Class: ARS 50
- 9.036 Crane
- Aft Capstans
- Bow Thruster
- Communications equipment
- Diver Support Boat
- Hull Form
- OOC2 Salvage and Towing Assets
- OOC2 Salvage Assets
- T-ARS(X)



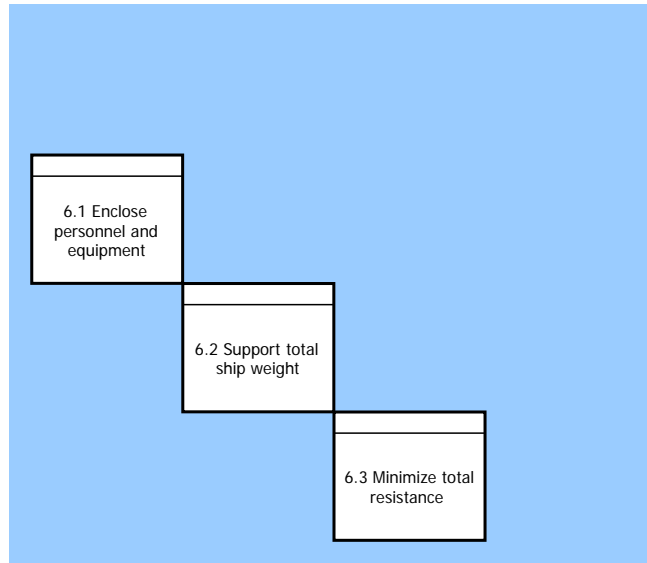
**Figure 31 6.0 Operate on surface of water Enhanced FFBD**



**Figure 32 6.0 Operate on surface of water FFBD**

# 10 Components

---



**Figure 33 6.0 Operate on surface of water N2 Diagram**

# 10 Components

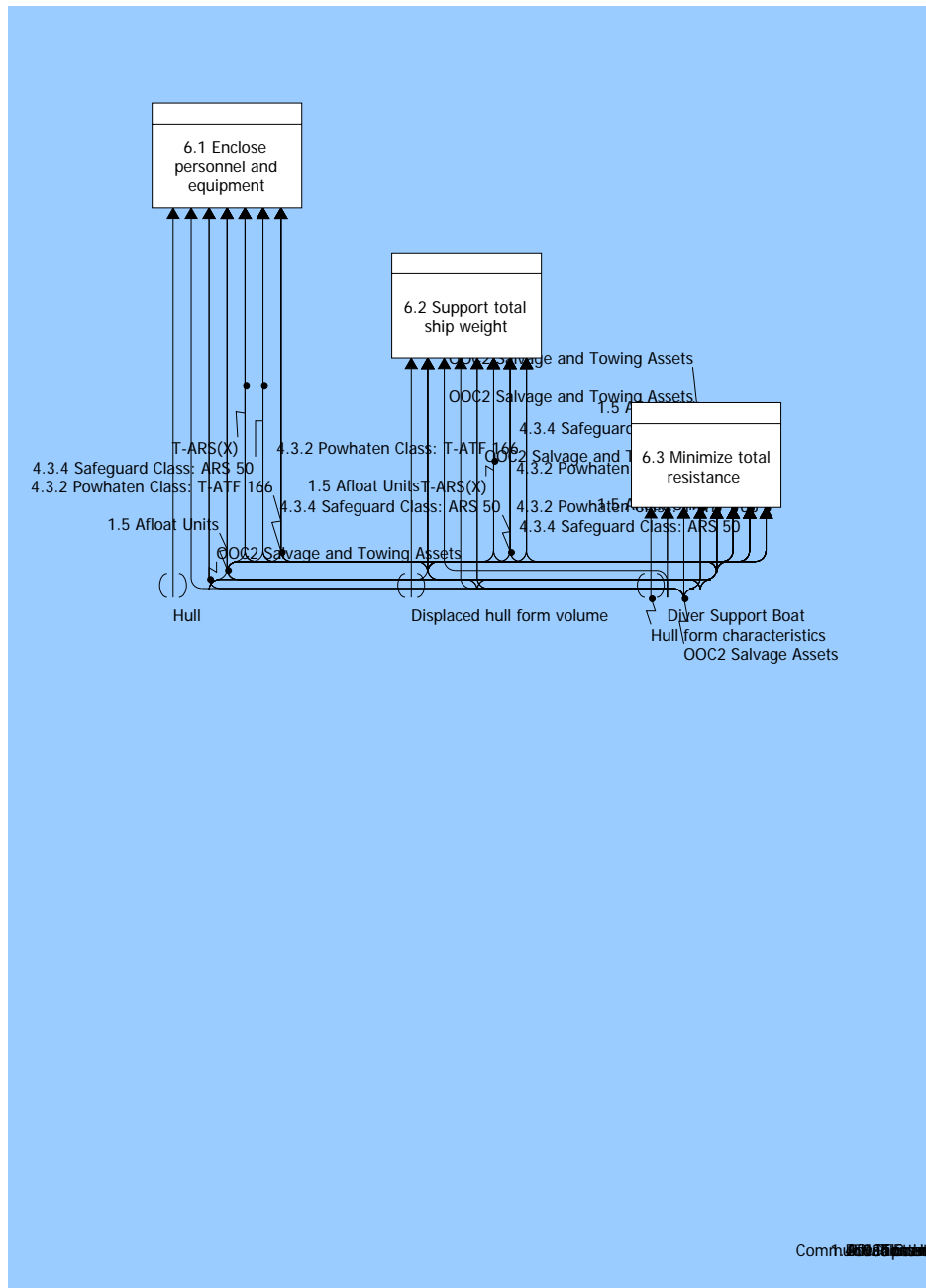


Figure 34 6.0 Operate on surface of water IDEF0 Diagram

## 6.1 Enclose personnel and equipment

Allocated To:

- 1.5 Afloat Units
- 4.3.2 Powhatan Class: T-ATF 166
- 4.3.4 Safeguard Class: ARS 50
- Hull
- OOC2 Salvage and Towing Assets
- OOC2 Salvage Assets

# 10 Components

---

T-ARS(X)

Based On:

Salvage Equipment Stowage Space

## 6.2 Support total ship weight

Allocated To:

1.5 Afloat Units

4.3.2 Powhatan Class: T-ATF 166

4.3.4 Safeguard Class: ARS 50

Displaced hull form volume

Diver Support Boat

OOC2 Salvage and Towing Assets

OOC2 Salvage Assets

T-ARS(X)

## 6.3 Minimize total resistance

Allocated To:

1.5 Afloat Units

4.3.2 Powhatan Class: T-ATF 166

4.3.4 Safeguard Class: ARS 50

Diver Support Boat

Hull form characteristics

OOC2 Salvage and Towing Assets

OOC2 Salvage Assets

T-ARS(X)

## 7.0 Maintain Desired Position

Allocated To:

1.5 Afloat Units

4.3.2 Powhatan Class: T-ATF 166

4.3.4 Safeguard Class: ARS 50

Aft Capstans

Anchoring system

Bow Thruster

Controllable Reversible Pitch Propeller

Dynamic Positioning

Forward Anchor Capstan Windlass

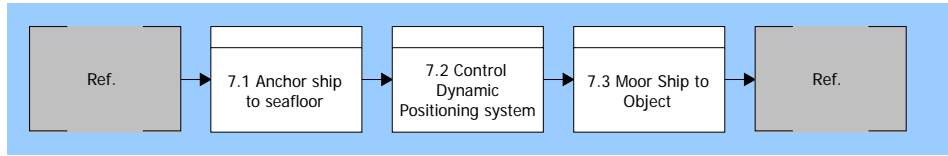
Fuel system

OOC2 Salvage and Towing Assets

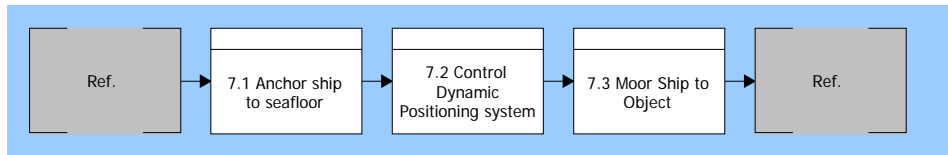
OOC2 Salvage Assets

T-ARS(X)

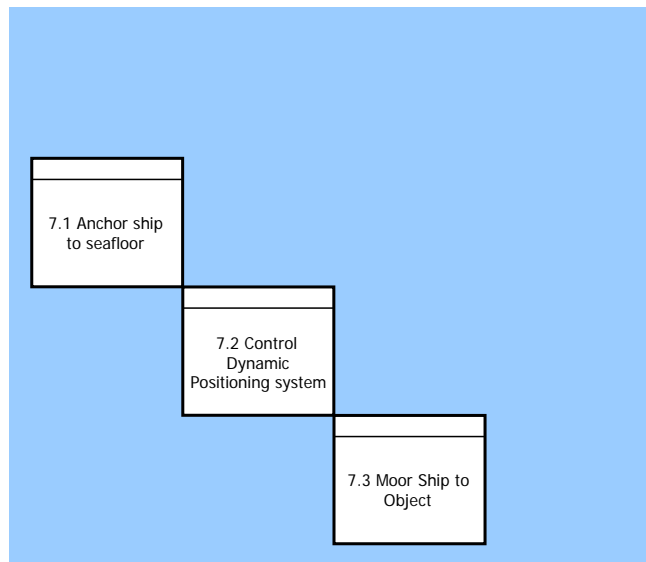
# 10 Components



**Figure 35 7.0 Maintain Desired Position Enhanced FFBD**

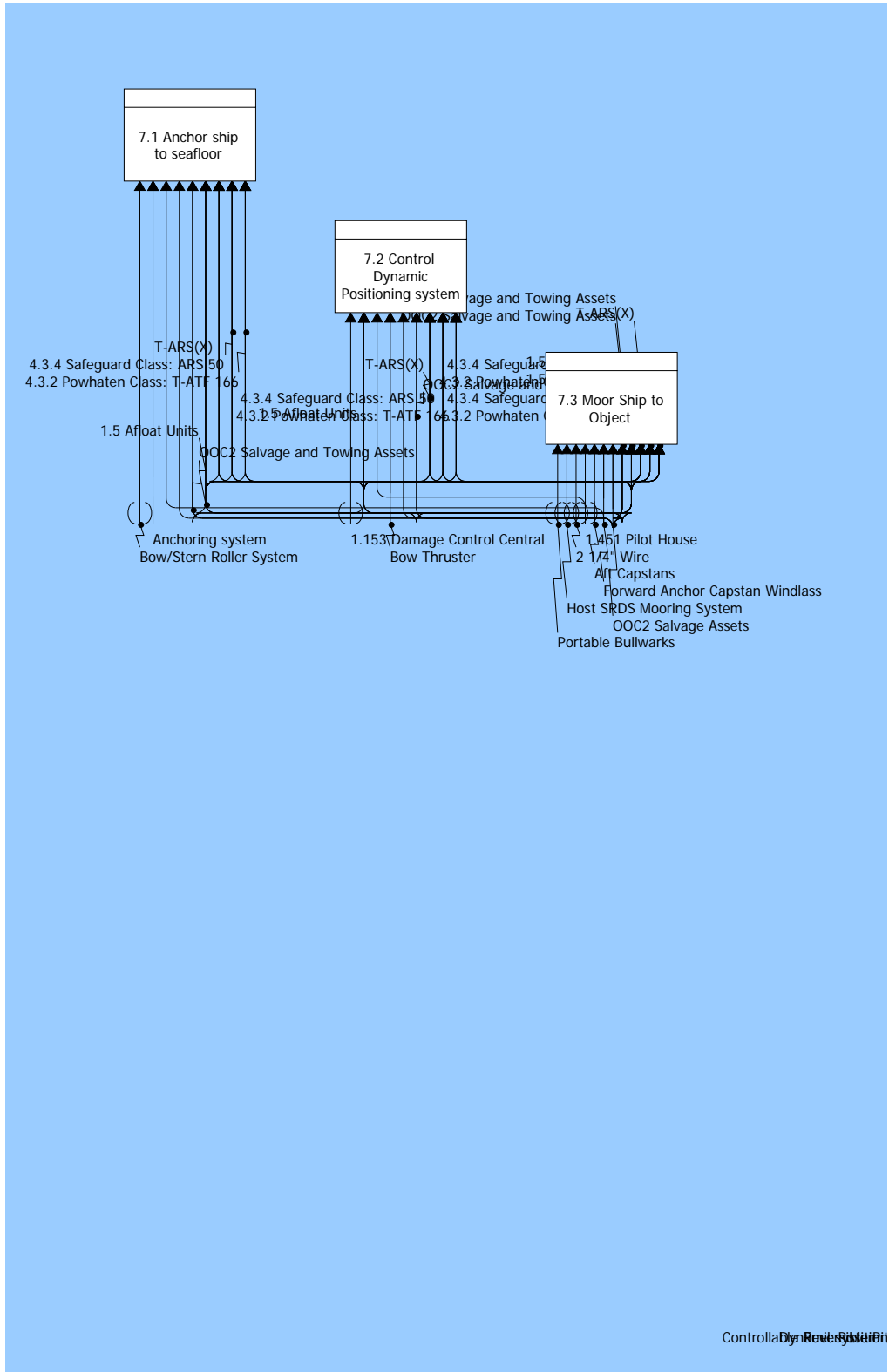


**Figure 36 7.0 Maintain Desired Position FFBD**



**Figure 37 7.0 Maintain Desired Position N2 Diagram**

# 10 Components



**Figure 38 7.0 Maintain Desired Position IDEF0 Diagram**



# 10 Components

---

## 7.1 Anchor ship to seafloor

Allocated To:

- 1.5 Afloat Units
- 4.3.2 Powhatan Class: T-ATF 166
- 4.3.4 Safeguard Class: ARS 50
- Anchoring system
- Bow/Stern Roller System
- Forward Anchor Capstan Windlass
- OOC2 Salvage and Towing Assets
- OOC2 Salvage Assets
- T-ARS(X)

## 7.2 Control Dynamic Positioning system

Allocated To:

- 1.153 Damage Control Central
- 1.451 Pilot House
- 1.5 Afloat Units
- 4.3.2 Powhatan Class: T-ATF 166
- 4.3.4 Safeguard Class: ARS 50
- Bow Thruster
- OOC2 Salvage and Towing Assets
- OOC2 Salvage Assets
- T-ARS(X)

## 7.3 Moor Ship to Object

Allocated To:

- 1.451 Pilot House
- 1.5 Afloat Units
- 2 1/4" Wire
- 4.3.2 Powhatan Class: T-ATF 166
- 4.3.4 Safeguard Class: ARS 50
- Aft Capstans
- Forward Anchor Capstan Windlass
- Host SRDS Mooring System
- OOC2 Salvage and Towing Assets
- OOC2 Salvage Assets
- Portable Bullwarks
- T-ARS(X)

## 8.0 Conduct beach retraction operations

Allocated To:

- 1.125 Consolidated Divers Unit
- 1.5 Afloat Units
- 2 1/4" Wire
- 4.3.2 Powhatan Class: T-ATF 166
- 4.3.4 Safeguard Class: ARS 50
- Aft Capstans

# 10 Components

---

Beach Gear  
Bow/Stern Roller System  
Controllable Reversible Pitch Propeller  
Forward Anchor Capstan Windlass  
Hydraulic Power Packs  
Lateral Control Winch  
OOC2 Salvage and Towing Assets  
OOC2 Salvage Assets  
Portable Bullwarks  
T-ARS(X)

## 9.0 Conduct Firefighting Operations

Allocated To:

1.153 Damage Control Central  
1.5 Afloat Units  
4.3.2 Powhatan Class: T-ATF 166  
4.3.4 Safeguard Class: ARS 50  
Damage control systems and equipment  
Firefighting Monitors  
OOC2 Salvage and Towing Assets  
OOC2 Salvage Assets  
Portable Firefighting Equipment  
T-ARS(X)

Based On:

Firefighting Flow Rate

---

# 10 Components

---

## T-ARS(X)

- 100 Hull structure
  - Hull
  - Hull Form
  - Hull form characteristics
- 200 Propulsion plant
- 300 Electric plant
- 400 Command and surveillance
- 500 Auxiliary system
- 600 Outfit and furnishings
- 700 Armament
- 800 Integration/Engineering
- 900 Ship assembly and support systems

---

## Part II - Component Definitions

---

### T-ARS(X)

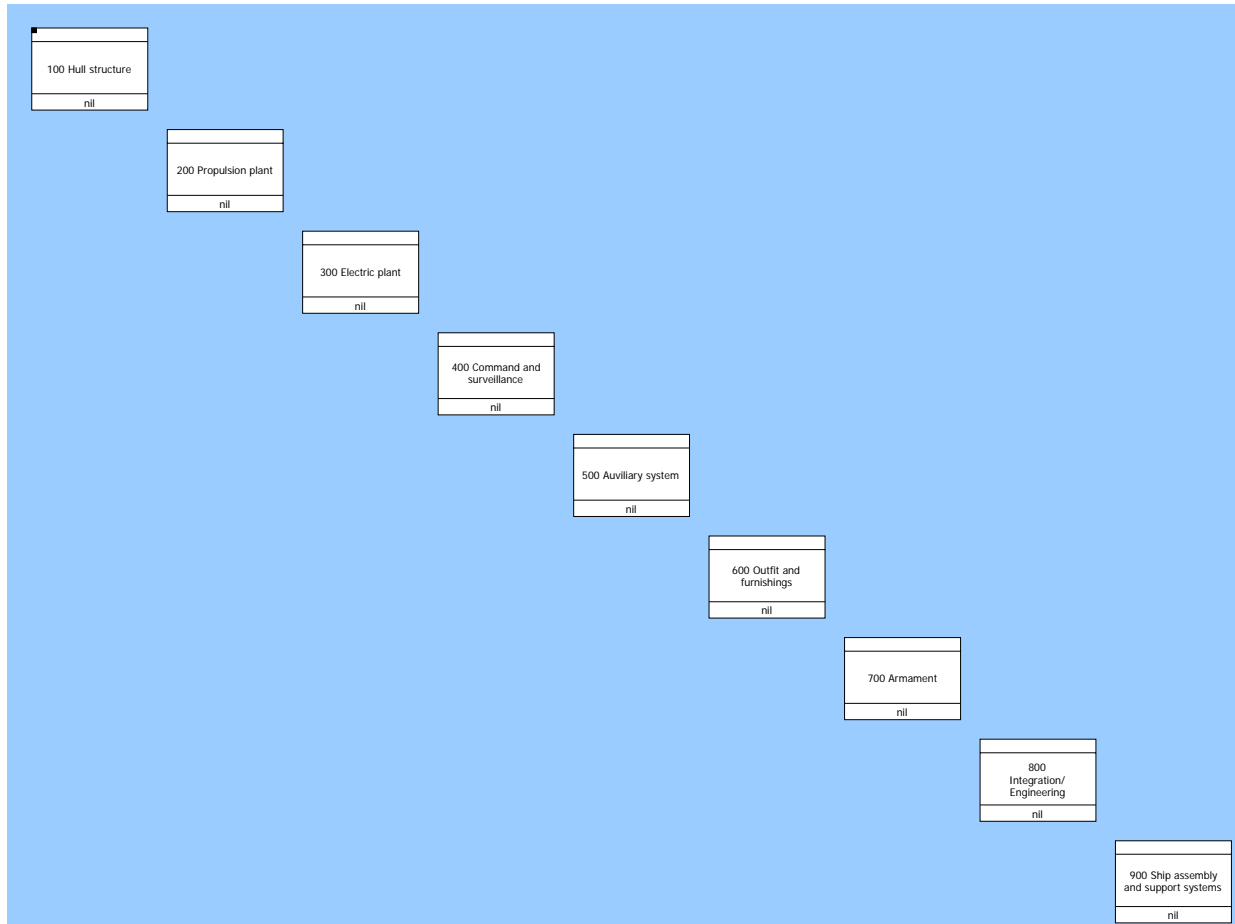
#### Built In Higher-Level Component(s):

- 1.5 Afloat Units

#### Built From Lower-Level Component(s):

- 100 Hull structure
- 200 Propulsion plant
- 300 Electric plant
- 400 Command and surveillance
- 500 Auxiliary system
- 600 Outfit and furnishings
- 700 Armament
- 800 Integration/Engineering
- 900 Ship assembly and support systems

# 10 Components



**Figure 39 T-ARS(X) Subcomponent Connectivity**

Performs Function(s):

- 1.0 Move through the water
- 1.1 Produce propulsive power to achieve sustained speed
- 1.2 Provide propulsive power at usable speed (rpm)
- 1.3 Transfer power to water
- 1.4 Control speed and direction of movement locally
- 1.5 Control speed and direction of movement remotely
- 10.0 Conduct pollution response
- 10.1 Provides Pollution Logistics support
- 11.0 Conduct Pollution Training
- 13.0 Conduct Diving Operations other than salvage
- 14.0 Conduct Personnel Rescue Operations
- 15.0 Conduct Underway Replenishment Operations
- 2.0 Maintain Desired Course
- 2.1 Determine if course is safe
- 2.2 Alter existing course
- 2.3 Maneuver alongside pier
- 3.0 Conduct Salvage Operations
- 3.1 Conduct Collision Repair
- 3.1 Conduct diving Operations

# 10 Components

---

- 3.1.1 Conduct Underwater Inspections
- 3.1.2 Conduct Underwater Welding
- 3.2 Conduct Ocean Search and Recovery
  - 3.2.1 Conduct Heavy Lift Operations
- 3.3 Retrieve vessel from beach
- 3.3 Transport/secure salvaged system or equipment
- 4.0 Conduct towing operations
  - 4.1 Connect tow line to vessel
  - 4.2 Position ship for towing operations
  - 4.3 Tow vessel through water
- 5.0 Conduct sustained operations underway
  - 5.1 Ensure habitable conditions
  - 5.2 Maintain equipment in operating condition
  - 5.3 Communicate information
  - 5.4 Combat damage
  - 5.5 Secure Condition while underway
  - 5.6 Secure position while in port
  - 5.7 Provide electrical power
  - 5.8 Provide fuel source
- 6.0 Operate on surface of water
  - 6.1 Enclose personnel and equipment
  - 6.2 Support total ship weight
  - 6.3 Minimize total resistance
- 7.0 Maintain Desired Position
  - 7.1 Anchor ship to seafloor
  - 7.2 Control Dynamic Positioning system
  - 7.3 Moor Ship to Object
- 8.0 Conduct beach retraction operations
- 9.0 Conduct Firefighting Operations

Specified By:

- Bollard Pull
- Civilian Crew
- Dynamic Positioning
- Endurance
- Firefighting Flow Rate
- Ice Classification
- Navy Personnel Accommodation
- Primary Crane Lift Capacity
- Salvage Equipment Stowage Space
- Secondary Crane Lift Capacity
- Speed
- Unobstructed Deck Space; Aft
- Unobstructed Deck Space; Fwd

## 100 Hull structure

Built In Higher-Level Component(s):

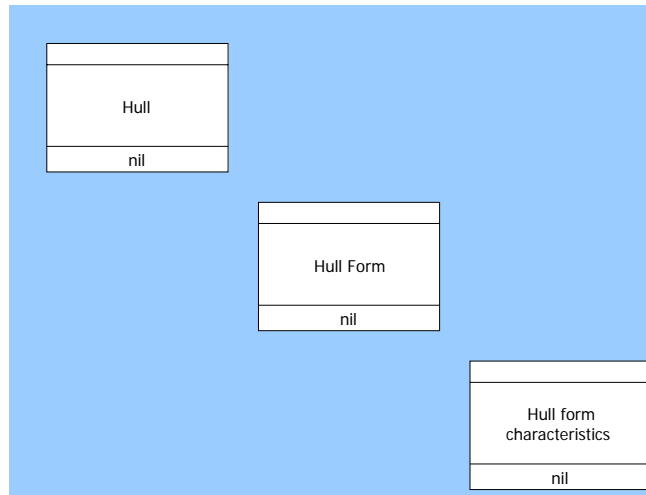
T-ARS(X)

Built From Lower-Level Component(s):

# 10 Components

---

Hull  
Hull Form  
Hull form characteristics



**Figure 40 100 Hull structure Subcomponent Connectivity**

## **Hull**

Built In Higher-Level Component(s):  
100 Hull structure

Performs Function(s):  
6.1 Enclose personnel and equipment

## **Hull Form**

Built In Higher-Level Component(s):  
100 Hull structure

Performs Function(s):  
6.0 Operate on surface of water

## **Hull form characteristics**

Built In Higher-Level Component(s):  
100 Hull structure

Performs Function(s):  
6.3 Minimize total resistance

## **200 Propulsion plant**

Built In Higher-Level Component(s):  
T-ARS(X)

## **300 Electric plant**

Built In Higher-Level Component(s):

# 10 Components

---

T-ARS(X)

## **400 Command and surveillance**

Built In Higher-Level Component(s):  
T-ARS(X)

## **500 Auxiliary system**

Built In Higher-Level Component(s):  
T-ARS(X)

## **600 Outfit and furnishings**

Built In Higher-Level Component(s):  
T-ARS(X)

## **700 Armament**

Built In Higher-Level Component(s):  
T-ARS(X)

## **800 Integration/Engineering**

Built In Higher-Level Component(s):  
T-ARS(X)

## **900 Ship assembly and support systems**

Built In Higher-Level Component(s):  
T-ARS(X)

---

**Part I - Derived Functional Interfaces**

---

---

**Part II - Logical Interfaces**

---

---

**Part III - Physical Interfaces**

---



<b>Allocated Capabilities/Requirements</b>	<b>Traced From Higher-Level Elements</b>
<b>T-ARS(X) (Component)</b>	
1.0 Move through the water (Function)	Speed (Requirement) Ice Classification (Requirement) OOC2 Salvage and Towing Assets (Component) 1.5 Afloat Units (Component) OOC2 Salvage Assets (Component)
Endurance (Requirement)	
1.1 Produce propulsive power to achieve sustained speed (Function)	Speed (Requirement) OOC2 Salvage and Towing Assets (Component) 1.5 Afloat Units (Component) OOC2 Salvage Assets (Component)
1.2 Provide propulsive power at usable speed (rpm) (Function)	Speed (Requirement) OOC2 Salvage and Towing Assets (Component) 1.5 Afloat Units (Component) OOC2 Salvage Assets (Component)
1.3 Transfer power to water (Function)	Speed (Requirement) OOC2 Salvage and Towing Assets (Component) 1.5 Afloat Units (Component) OOC2 Salvage Assets (Component)
1.4 Control speed and direction of movement locally (Function)	Speed (Requirement) OOC2 Salvage and Towing Assets (Component) 1.5 Afloat Units (Component) OOC2 Salvage Assets (Component)
1.5 Control speed and direction of movement remotely (Function)	Speed (Requirement) OOC2 Salvage and Towing Assets (Component) 1.5 Afloat Units (Component) OOC2 Salvage Assets (Component)
10.0 Conduct pollution response (Function)	OOC2 Salvage and Towing Assets (Component) 1.5 Afloat Units (Component)
10.1 Provides Pollution Logistics support (Function)	OOC2 Salvage and Towing Assets (Component)
11.0 Conduct Pollution Training (Function)	1.5 Afloat Units (Component)
13.0 Conduct Diving Operations other than salvage (Function)	OOC2 Salvage and Towing Assets (Component) 1.5 Afloat Units (Component) OOC2 Salvage Assets (Component)
14.0 Conduct Personnel Rescue Operations (Function)	OOC2 Salvage and Towing Assets (Component) 1.5 Afloat Units (Component) OOC2 Salvage Assets (Component)
15.0 Conduct Underway Replenishment Operations	OOC2 Salvage and Towing Assets (Component)

Allocated Capabilities/Requirements	Traced From Higher-Level Elements
(Function)	1.5 Afloat Units (Component) OOC2 Salvage Assets (Component)
2.0 Maintain Desired Course (Function)	OOC2 Salvage and Towing Assets (Component) 1.5 Afloat Units (Component) OOC2 Salvage Assets (Component)
2.1 Determine if course is safe (Function)	OOC2 Salvage and Towing Assets (Component) 1.5 Afloat Units (Component) OOC2 Salvage Assets (Component)
2.2 Alter existing course (Function)	OOC2 Salvage and Towing Assets (Component) 1.5 Afloat Units (Component) OOC2 Salvage Assets (Component)
2.3 Maneuver alongside pier (Function)	Dynamic Positioning (Requirement) OOC2 Salvage and Towing Assets (Component) 1.5 Afloat Units (Component) OOC2 Salvage Assets (Component)
3.0 Conduct Salvage Operations (Function)	Unobstructed Deck Space; Fwd (Requirement) Primary Crane Lift Capacity (Requirement) Secondary Crane Lift Capacity (Requirement) 1.5 Afloat Units (Component) OOC2 Salvage and Towing Assets (Component) Unobstructed Deck Space; Aft (Requirement) Dynamic Positioning (Requirement) OOC2 Salvage Assets (Component)
3.1 Conduct Collision Repair (Function)	OOC2 Salvage and Towing Assets (Component) 1.5 Afloat Units (Component) OOC2 Salvage Assets (Component)
3.1 Conduct diving Operations (Function)	Dynamic Positioning (Requirement) OOC2 Salvage and Towing Assets (Component) OOC2 Salvage Assets (Component)
3.1.1 Conduct Underwater Inspections (Function)	OOC2 Salvage and Towing Assets (Component) 1.5 Afloat Units (Component) OOC2 Salvage Assets (Component)
3.1.2 Conduct Underwater Welding (Function)	OOC2 Salvage and Towing Assets (Component) 1.5 Afloat Units (Component) OOC2 Salvage Assets (Component)
3.2 Conduct Ocean Search and Recovery (Function)	Dynamic Positioning (Requirement) OOC2 Salvage and Towing Assets (Component) 1.5 Afloat Units (Component) Secondary Crane Lift Capacity (Requirement) OOC2 Salvage Assets (Component)

Allocated Capabilities/Requirements	Traced From Higher-Level Elements
3.2.1 Conduct Heavy Lift Operations (Function)	Primary Crane Lift Capacity (Requirement) Secondary Crane Lift Capacity (Requirement) 1.5 Afloat Units (Component) OOC2 Salvage and Towing Assets (Component) Dynamic Positioning (Requirement) OOC2 Salvage Assets (Component)
3.3 Retrieve vessel from beach (Function)	Bollard Pull (Requirement) OOC2 Salvage and Towing Assets (Component) 1.5 Afloat Units (Component) OOC2 Salvage Assets (Component)
3.3 Transport/secure salvaged system or equipment (Function)	Salvage Equipment Stowage Space (Requirement) OOC2 Salvage and Towing Assets (Component) Unobstructed Deck Space; Aft (Requirement) Unobstructed Deck Space; Fwd (Requirement) OOC2 Salvage Assets (Component)
4.0 Conduct towing operations (Function)	Bollard Pull (Requirement) OOC2 Salvage and Towing Assets (Component) 1.5 Afloat Units (Component)
4.1 Connect tow line to vessel (Function)	OOC2 Salvage and Towing Assets (Component) 1.5 Afloat Units (Component)
4.2 Position ship for towing operations (Function)	Dynamic Positioning (Requirement) OOC2 Salvage and Towing Assets (Component) 1.5 Afloat Units (Component)
4.3 Tow vessel through water (Function)	Bollard Pull (Requirement) OOC2 Salvage and Towing Assets (Component) 1.5 Afloat Units (Component)
5.0 Conduct sustained operations underway (Function)	OOC2 Salvage and Towing Assets (Component) 1.5 Afloat Units (Component) OOC2 Salvage Assets (Component)
5.1 Ensure habitable conditions (Function)	Navy Personnel Accommodation (Requirement) OOC2 Salvage and Towing Assets (Component) 1.5 Afloat Units (Component) Civilian Crew (Requirement) OOC2 Salvage Assets (Component)
5.2 Maintain equipment in operating condition (Function)	OOC2 Salvage and Towing Assets (Component) 1.5 Afloat Units (Component) OOC2 Salvage Assets (Component)
5.3 Communicate information (Function)	OOC2 Salvage and Towing Assets (Component) 1.5 Afloat Units (Component) OOC2 Salvage Assets (Component)

Allocated Capabilities/Requirements	Traced From Higher-Level Elements
5.4 Combat damage (Function)	OOC2 Salvage and Towing Assets (Component) 1.5 Afloat Units (Component) OOC2 Salvage Assets (Component)
5.5 Secure Condition while underway (Function)	OOC2 Salvage and Towing Assets (Component) 1.5 Afloat Units (Component) OOC2 Salvage Assets (Component)
5.6 Secure position while in port (Function)	OOC2 Salvage and Towing Assets (Component) 1.5 Afloat Units (Component) OOC2 Salvage Assets (Component)
5.7 Provide electrical power (Function)	OOC2 Salvage and Towing Assets (Component) 1.5 Afloat Units (Component) OOC2 Salvage Assets (Component)
5.8 Provide fuel source (Function)	OOC2 Salvage and Towing Assets (Component) 1.5 Afloat Units (Component) OOC2 Salvage Assets (Component)
6.0 Operate on surface of water (Function)	OOC2 Salvage and Towing Assets (Component) 1.5 Afloat Units (Component) OOC2 Salvage Assets (Component)
6.1 Enclose personnel and equipment (Function)	Salvage Equipment Stowage Space (Requirement) OOC2 Salvage and Towing Assets (Component) 1.5 Afloat Units (Component) OOC2 Salvage Assets (Component)
6.2 Support total ship weight (Function)	OOC2 Salvage and Towing Assets (Component) 1.5 Afloat Units (Component) OOC2 Salvage Assets (Component)
6.3 Minimize total resistance (Function)	OOC2 Salvage and Towing Assets (Component) 1.5 Afloat Units (Component) OOC2 Salvage Assets (Component)
7.0 Maintain Desired Position (Function)	OOC2 Salvage and Towing Assets (Component) 1.5 Afloat Units (Component) OOC2 Salvage Assets (Component)
7.1 Anchor ship to seafloor (Function)	OOC2 Salvage and Towing Assets (Component) 1.5 Afloat Units (Component) OOC2 Salvage Assets (Component)
7.2 Control Dynamic Positioning system (Function)	OOC2 Salvage and Towing Assets (Component) 1.5 Afloat Units (Component) OOC2 Salvage Assets (Component)
7.3 Moor Ship to Object (Function)	OOC2 Salvage and Towing Assets (Component) 1.5 Afloat Units (Component) OOC2 Salvage Assets (Component)

<b>Allocated Capabilities/Requirements</b>	<b>Traced From Higher-Level Elements</b>
8.0 Conduct beach retraction operations (Function)	OOC2 Salvage and Towing Assets (Component) 1.5 Afloat Units (Component) OOO2 Salvage Assets (Component)
9.0 Conduct Firefighting Operations (Function)	Firefighting Flow Rate (Requirement) OOO2 Salvage and Towing Assets (Component) 1.5 Afloat Units (Component) OOO2 Salvage Assets (Component)
Bollard Pull (Requirement)	
Civilian Crew (Requirement)	
Dynamic Positioning (Requirement)	
Endurance (Requirement)	
Firefighting Flow Rate (Requirement)	
Ice Classification (Requirement)	
Navy Personnel Accomodation (Requirement)	
Primary Crane Lift Capacity (Requirement)	
Salvage Equipment Stowage Space (Requirement)	
Secondary Crane Lift Capacity (Requirement)	
Speed (Requirement)	
Unobstructed Deck Space; Aft (Requirement)	
Unobstructed Deck Space; Fwd (Requirement)	
<b>100 Hull structure (Component)</b>	
<b>Hull (Component)</b>	
6.1 Enclose personnel and equipment (Function)	Salvage Equipment Stowage Space (Requirement) OOO2 Salvage and Towing Assets (Component) 1.5 Afloat Units (Component) OOO2 Salvage Assets (Component)
<b>Hull Form (Component)</b>	
6.0 Operate on surface of water (Function)	OOO2 Salvage and Towing Assets (Component) 1.5 Afloat Units (Component) OOO2 Salvage Assets (Component)
<b>Hull form characteristics (Component)</b>	
6.3 Minimize total resistance (Function)	OOO2 Salvage and Towing Assets (Component) 1.5 Afloat Units (Component) OOO2 Salvage Assets (Component)
<b>200 Propulsion plant (Component)</b>	
<b>300 Electric plant (Component)</b>	
<b>400 Command and surveillance (Component)</b>	

Allocated Capabilities/Requirements	Traced From Higher-Level Elements
<b>500</b> Auviliary system (Component)	
<b>600</b> Outfit and furnishings (Component)	
<b>700</b> Armament (Component)	
<b>800</b> Integration/Engineering (Component)	
<b>900</b> Ship assembly and support systems (Component)	

## LIST OF REFERENCES

- Architectural Framework Forum. 2008 [<http://architectureframework.com/faq/>] May, 2008
- Biggs, B. (2005, February 17). Ministry of defence architectural framework (MODAF). IEE Presentation. Royal Navy.
- Boardman, J., & Sauser, B. (2008, January). "Systems thinking: Coping with 21st century problems."
- Defense Acquisition University (DAU) (2001, January). "Systems Engineering Fundamentals."
- DeLaurentis, D. (2007). "Research foundations." School of Aeronautics and Astronautics, Purdue University, West Lafayette, IN
- Department of Defense. (2007, 1 May). "Joint capabilities integration and development system." CJCSI 3170.01F
- Department of Defense. (2005). "Joint capabilities integration and development system." CJCSI 3170.01E, 2005.
- Department of Defense, (DODAF) (2004, February 9). "Architecture framework, Vol. I: Definitions and guidelines."
- Department of the Navy. (1997, July). United States navy salvage engineer's handbook, Vol. 1 (Salvage Engineering). S0300-A8-HBK-101. , Washington Navy Yard, D.C.: Naval Sea Systems Command.
- Department of the Navy. US Navy TOWMAN.
- Department of the Navy. (2002, December). ARS-50 Class operations handbook, SS500-AM-MMO-010, Vol. 1 Rev 1. Port Hueneme, CA: Naval Sea Systems Command.
- Department of the Navy (OPNAVINST 4740.2G), Jan 2008
- Department of the Navy (Naval Warfare Publication, NWP 4-12).
- Department of the Navy (COMSCINST 3191.9B).
- Department of the Navy. (1988, January 5). "Projected operational environment (POE) and required operational capabilities (ROC) for the powhatan (TATF 166) class with MSC manning." OPNAV Instruction 3501.177.

Department of the Navy. (2007, 13 November). "Projected operational environment (POE) and required operational capabilities (ROC) for the T-ARS 50 (safeguard) class salvage ship with MSC manning." OPNAV Instruction 3501.136b.

Engineering Colloquium, MITRE Corporation, 2008.

Federation of American Scientists (<http://www.fas.org/man/dod-101/sys/ship/tatf-166.htm>). 2008

Fein, G. (2008, August 21). "Navy developing path forward for open architecture implementation." Defense Daily

Giammarco, Kristen 2007. "Data Centric Integration and Analysis of Information Technology Architectures."

Huynh, T.V., & Osmundson, J.S. (2007). "An integrated systems engineering Methodology for analyzing systems of systems architectures."

IEEE 1220 (2006)

INCOSE Resp Group. (2004, 11 June). Genesis of INCOSE.

International Council on Systems Engineering (INCOSE). Retrieved March 2008 from [<http://www.incose.org/practice/whatisystemseng.aspx>].

Light, C. (2007, December). Salvage platform POM10 shipbuilding. PowerPoint Presentation, OPNAV N42.

Lonsdale, M.V. (2008). "Performance under pressure. Navy deep sea diving equipment."

Maier, M & Rechtin, E (2002). "The Art of Systems Architecting." CRC Press.

Martin, J.N., (2007). "Processes for engineering a system." EIA 632 Working Group. Raytheon Systems Company.

Martin, J.N. (2007). "Processes for engineering a system." Overview of the EIA 632 Standard. EIA 632 Working Group, Raytheon Systems Company.

Mercer, B. (2007). "Thoughts on architecting, and how to improve the practice." PowerPoint Presentation to the Naval Postgraduate School

NASA. (1995). *NASA Systems Engineering Handbook*. SP-610S.

NAVSEA SUPSALV Website ([www.supsalv.org](http://www.supsalv.org)).2008

Office of the Assistant Secretary of Defense for Networks and Information Integration 2005.



- Richards, M.G., Shah, N.B., Hastings, D.E., & Rhodes, D.H. (2007). "Architecture frameworks in system design: Motivation, theory, and implementation."
- Ring, Jack "Discovering the Architecture for Product X" INCOSE Conference Proceedings, 2001,
- Sage, A.P. (1992). Systems Engineering. Wiley IEEE.
- Sage, A.P., & Biemer, S.M. (2007). "Process for system family architecting, design, and integration." IEEE
- Saunders, T. *et al*, "United States Air Force Scientific Advisory Board Report on System-of-Systems Engineering for Air Force Capability Development," SAB-TR-05-04, July 2005.
- Schlager, J. (July,1956). "Systems engineering: key to modern development." IRE Transactions, EM-3: pp. 64-66.
- Sessions, Roger, "Perspectives of the International Association of Software Architects", April 2007.
- Siel, C.R., Jr. (2007, August). "Architecture elements reference guide configuration management procedures."
- Skolnick, F.R., & Wilkins, P.G. (2000). "Laying the foundation for successful systems engineering."
- Sperling, R., & Keenan, J.D. (2006, November). "Navy salvage ship recapitalization study," CRM D0014544.A1/Final.
- System of Systems Engineering Center of Excellence (SoSECE), 2008.
- TB-55-1900-232-10, U.S. Army Towing Manual.
- The American Heritage Dictionary of the English Language, 4th edition. (2000). Houghton, Mifflin Company.
- TOGAF "The Open Group Architecture Framework (TOGAF)," 2007.
- Ulrich, Karl T. and Steven D. Eppinger "Product Design and Development," (McGraw-Hill, 2004)
- Whaley, B. (2007, February 13-14). United States Federal Diving Programs Conference.
- Whitcomb, C., Vaidyanathan, R., Pluta, J., Kiihne, J., & Solitario, W. (2008, 6-8 April). "Architecture development for an unmanned vehicle sentry systems of systems." 23<sup>rd</sup> Bristol International Unmanned Air Vehicle Systems (UAVS) Conference, Bristol, UK.

Walker, S.K. (2005). “Capabilities-based planning – How it is intended to work and challenges to its successful implementation.”

Zachman Institute for Framework Advancement (ZIFA) (<http://www.zifa.com/>). May 2008

## INITIAL DISTRIBUTION LIST

1. Defense Technical Information Center  
Ft. Belvoir, Virginia
2. Dudley Knox Library  
Naval Postgraduate School  
Monterey, California
3. CAPT Hooper, 00C  
Commander, Naval Sea Systems Command  
Washington Navy Yard, D.C.
4. LT Robert Williams, 00C2OA  
Commander, Naval Sea Systems Command  
Washington Navy Yard, D.C.
5. LCDR Jay Young, 00C5  
Commander, Naval Sea Systems Command  
Washington Navy Yard, D.C.