

TS

2025

B5

PRACTICAL
PROBLEMS
FOR
VEHICLE
DRAFTSMEN AND MECHANICS



Class TS2025

Book B5

Copyright N^o _____

COPYRIGHT DEPOSIT.

R. B. BIRGE and HUGH M. SARGENT, Authors

PRACTICAL PROBLEMS

FOR

VEHICLE DRAFTSMEN AND MECHANICS



WARE BROS. COMPANY, Publishers

1010 Arch Street, Philadelphia, Pa.

TS 5
.B5

COPYRIGHT BY
BIRGE & SARGENT
1912

12-11930

5

© Cl. A369164

40.1

CONTENTS

	PAGE
Introduction	4
Geometrical Terms and Definitions.....	5
To Divide a Line in Any Number of Equal Parts.....	10
To Lay Out True Sweeps or Curves.....	11
To Find the Radius of an Arc.....	13
To Lay Out Ovals.....	14
The Application of the Proportional Triangle for Laying Out Twisted or Winding Surfaces.....	16
Construction of Joints.....	18
Laying Out a Proportional Corner, Using Proportional Triangles..	22
Laying Out a Proportional Corner, Using Parallel Lines and Intersections	24
Laying Out Seat Panels, the Dihedral Angle and Mitters of a Wagon Seat	26
The Framing of Bodies With Contracted and Flared Sides.....	28

The Proportional Corner, Horizontal Section.....
Laying Out Twisted or Winding Surfaces.....
Laying Out a Belt Line and Moulding.....
Pricking Off Corner Pillar on Twisted Surface.....
Laying Out a Coupé Pillar.....
Framing Up a Door.....
The Construction of Glass Frames.....
Laying Out a Wheel House and Rear Mud Guard.....
Laying Out a Pattern of Panel for a Metal Wheel House.....
Laying Out a Pattern for a Shroud Panel.....
Laying Out Patterns for a Front Mud Guard.....
Perspective Drawing of Vehicles.....
Coloring Carriage and Automobile Drawings.....
Working Drafts

INTRODUCTION

work is the outgrowth of practical experience in the classroom. The authors, while intimately connected with the vehicle industry, in 1909 conducted a training school in carriage drafting, the pupils of which, about twenty-five in number, were all employes of the industry. The results of the first year were so successful that much benefit was experienced by the students and continued through another year with an equally

successful instruction proceeded, many problems came up in connection with the highly technical work of the carriage maker. These problems were exactly such as are met any day in actual practice in any vehicle drafting office which the student finds himself employed. Notes on the practical problems, and their solutions, and the reasons therefor, form the basis or foundation for the present volume.

Problems that had been answered and elucidated in other books have been incorporated in this book a number of such problems, and the whole is now offered to all mechanics in the vehicle trade who are seeking to obtain a technical education in order to advance themselves in their profession. Altogether with the object of aiding aspiring workers, this book was compiled and placed on the market.

Knowledge of elementary plane geometry is indispensably necessary to understand the principles upon which the art of drafting is based. For the benefit of those who have not had this preliminary training the subject has been

introduced in the first section of the book. A careful perusal of this section will give the student an insight into the principles of plane geometry, and enable him to more clearly understand the technical terms necessarily employed later on. These principles are in fact very simple and easy to understand, but because they are so important and so constantly referred to in practical drafting, it is necessary for the student to have a clear working knowledge of them.

It is the purpose of this book to teach not only the practical applications of each problem, but also to convey a familiarity with the principles underlying each problem. Therefore, in preparing each illustration, those parts have been selected which are as simple as the case may permit, although they are not always in the best proportion. In a number of instances it was necessary to exaggerate the relations of the lines in order to explain the problem to the best advantage.

Great care has been taken to have the drawings and text accurate as the authors could make them, but as most of the work was done by busy men in their evening hours, it is possible that a few errors may have escaped their notice. Should any one discover discrepancies or mistakes of any description in the book the authors and publishers will consider it a favor if the information is brought to their attention.

There has been an insistent demand for a book of this character from the actual workers in the vehicle trades, and if this book meets that demand, or serves in any manner toward elevating the standard of technical education among the vehicle mechanics for whose benefit it was compiled, the authors will feel more than gratified with such a reward for their labor.

R. B. BIRGE,
HUGH M. SARGENT.

Geometrical Terms and Definitions

A **LINE** is that which has length merely, and may be straight or curved.

A **STRAIGHT LINE**, or, as it is sometimes called, a right line, is the shortest line that can be drawn between two given points. Straight lines are generally designated by letters or figures at their extremities, as **A B**, Fig. 1.

A **CURVED LINE** is one which changes its direction at every point, or one of which no portion, however small, is straight. It is therefore longer than a straight line connecting the same points. Curved lines are designated by letters or figures at their extremities and at intermediate points, as **A B C** or **D E F**, Fig. 2.

PARALLEL LINES are those which have no inclination to each other, being everywhere equidistant. **A B** and **A' B'** in Fig. 3 are parallel straight lines, and can never meet, though produced to infinity. **C D** and **C' D'** are parallel curved lines, being arcs of circles which have a common center.

HORIZONTAL LINES are lines parallel to the horizon, or level. A Horizontal Line in a drawing is indicated by a line drawn from left to right across the paper, as **A B** in Fig. 4.

VERTICAL LINES are lines parallel to a plumb line suspended freely in a still atmosphere. A Vertical Line in a drawing is represented by a line drawn up and down the paper, or at right angles to a horizontal line, as **E C** in Fig. 4.

INCLINED OR OBLIQUE LINES occupy an intermediate between horizontal and vertical lines, as **C D**, Fig. 4.

Two lines which converge toward each other, if produced, would meet or intersect, as **A B** and **C D**, Fig. 5, other.

PERPENDICULAR LINES are two lines which are perpendicular to each other when the angles of meeting are equal. Vertical and horizontal lines are perpendicular to each other, but perpendicular lines are not always vertical and horizontal, but may be inclined to the horizon, provided that the angles of meeting at the point of intersection are equal. In Fig. 6, **E C** and **F D** are said to be perpendicular to **A B**. **C D** and **E F** are perpendicular to **A B**. **A B** and **C D** are the same line are parallel to each other, and **E C** and **F D** which are perpendicular to **A B**.

An **ANGLE** is the opening between two lines which meet one another. An angle is designated by three letters, the letter designating the vertex, and the other two letters, as the angle **E C D**.

A **RIGHT ANGLE**.—When two lines meet each other so as to make two equal angles, each angle is a right angle, and the lines are said to be perpendicular to each other, as **E C** and **A B**, Fig. 7.)

An **ACUTE ANGLE** is an angle less than a right angle, as **A B D** or **A B C**, Fig. 7.

An **OBTUSE ANGLE** is an angle greater than a right angle, as **A B E**, Fig. 7.

GEOMETRICAL TERMS AND DEFINITIONS—Continued

RIGHT-SIDED FIGURES.

A **RECTANGLE** is that which has length and breadth

A **PLANE SURFACE** is a surface such that if any two of its points are joined by a straight line, such line will be wholly in the surface which is not a plane surface, or curved surfaces, is a curved surface.

A **SMOOTH CURVED SURFACE** is one in which any two points may be joined by straight lines which shall be wholly in the surface. The rounded surface of a cylinder is a smooth curved surface.

A **ROUGH CURVED SURFACE** is one in which any two points may be joined by a straight line lying wholly outside the surface of spheres, for example, is a rough curved surface.

A **HYPOTENUSE** is the longest side in a right-angled triangle, the side opposite the right angle. **A C**, Fig. 9.

A **VERTEX** of a triangle is its upper extremity, as **B**, Fig. 9, is called vertex.

A **BASE** of a triangle is the line at the bottom. **BC**, Fig. 9, is called base.

A **PERIMETER** of a triangle are the including lines. **AC**, **BC**, and **AB**, Fig. 8 and 9.

A **VERTEX** is the point in any figure opposite to and opposite to the base. The vertex of an angle is the point where the sides of the angle meet. **B**, Fig. 9.

The **ALTITUDE** of a triangle is the length of a perpendicular let fall from its vertex to its base, as **BD**, Fig. 9.

A **QUADRILATERAL** figure is a surface bounded by four straight lines. There are three kinds of Quadrilaterals: The Trapezium, the Trapezoid, and the Parallelogram.

CIRCLES AND THEIR PROPERTIES

A **CIRCLE** is a plane figure bounded by a curved line, everywhere equidistant from its center. (Fig. 10.) (See also Circumference.)

The **CIRCUMFERENCE** of a circle is the boundary line of the figure. (Fig. 10.)

The **CENTER** of a circle is a point within the circumference equally distant from every point in its circumference, as **A**, Fig. 10.

The **RADIUS** of a circle is a line drawn from the center to any point in the circumference, as **AB**, Fig. 10, that is, half the diameter. The plural of radius is radii.

The **DIAMETER** of a circle is any straight line drawn through the center to opposite points of the circumference, as **CD**, Fig. 10.

A **SEMICIRCLE** is the half of a circle, and is bounded by half the circumference and a diameter. (Fig. 11.)

A **SEGMENT** of a circle is any part of its surface cut off by a straight line, as **AEB** and **CFD**, Fig. 12.

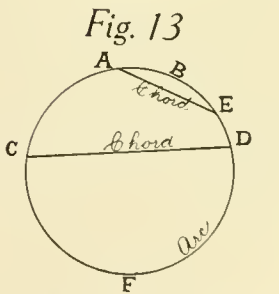
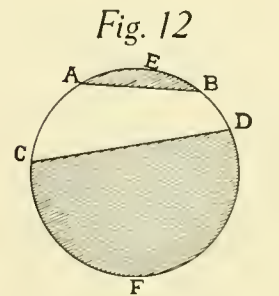
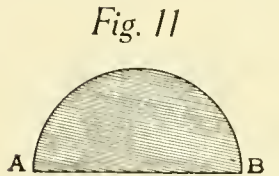
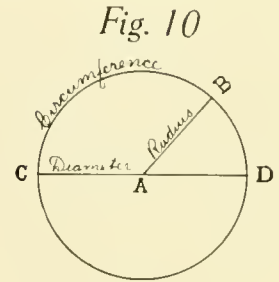
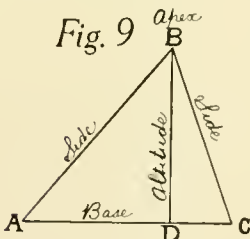
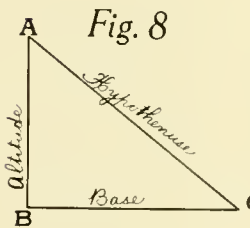
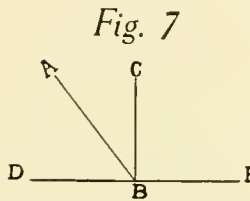
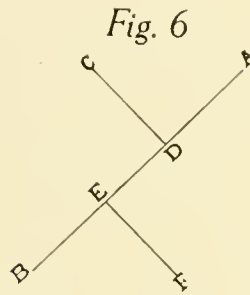
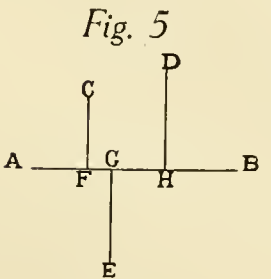
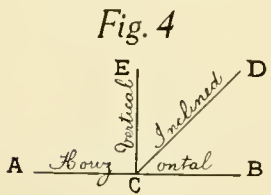
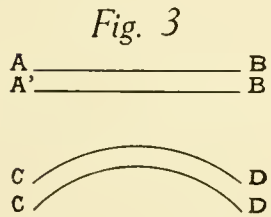
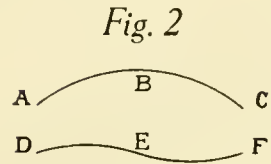
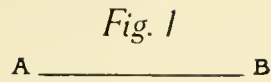

Concave

PRACTICAL PROBLEMS FOR VEHICLE DRAFTSMEN AND MECHANICS.

Fig. 1



Fig. 2



Fig. 3

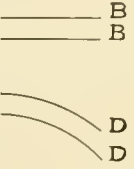

Fig. 4

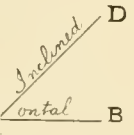

Fig. 5

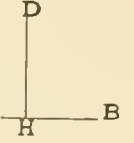

Fig. 6

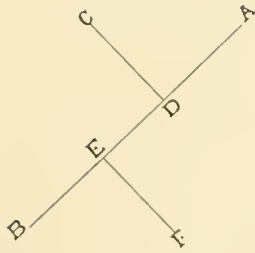

Fig. 7

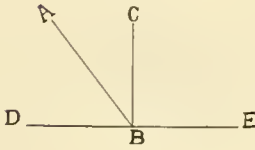

Fig. 8

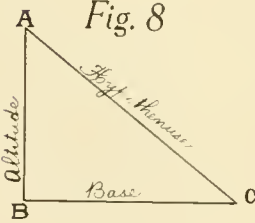

Fig. 9

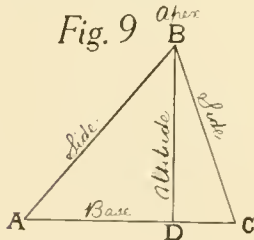

Fig. 10

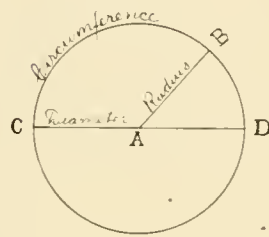

Fig. 11



Fig. 12

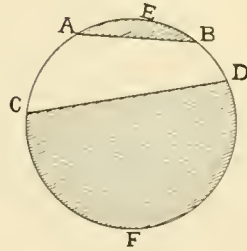

Fig. 13

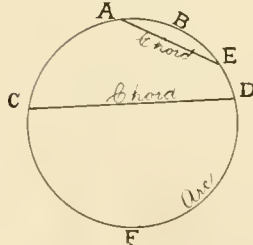

Fig. 14

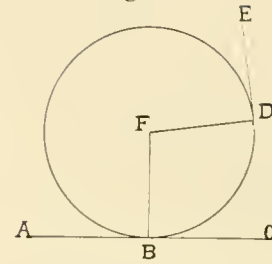

Fig. 15

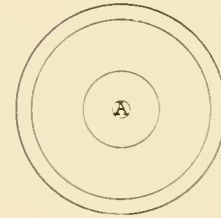

Fig. 16

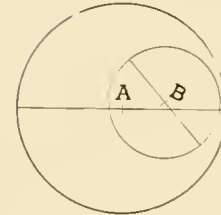
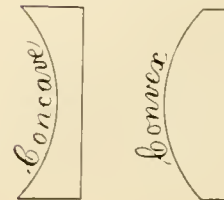

Fig. 17



ILLUSTRATIONS OF GEOMETRICAL TERMS AND DEFINITIONS.

GEOMETRICAL TERMS AND DEFINITIONS—Continued

An **ARC** of a circle is any part of the circumference, as *A B E* and *C F D*, Fig. 13.

A **CHORD** is a straight line joining the extremities of an arc, as *A E* and *C D*, Fig. 13.

A **TANGENT** to a circle or other curve is a straight line which touches it at only one point, as *E D* and *A C*, Fig. 14. Every tangent to a circle is perpendicular to the radius drawn to the point of tangency. Thus *E D* is perpendicular to *F D*, and *A C* to *F B*.

CONCENTRIC circles are those which are described about the same center. (Fig. 15.)

ECCENTRIC circles are those which are described about different centers. (Fig. 16.)

A **DEGREE**.—The circumference of a circle is considered as divided into 360 equal parts, called degrees (marked $^{\circ}$). Each degree is divided into 60 minutes (marked $'$); and each minute into 60 seconds (marked $''$). Thus if the circle be large or small the number of divisions is always the same, a degree being equal to $\frac{1}{360}$ part of the whole circumference: the semicircle is equal to 180° , and the quadrant to 90° . The radii drawn from the center of a circle to the extremities of a quadrant are always at right angles with each other; a right angle is therefore called an angle of 90° (*A E B*, Fig. 18). If a right angle be bisected by a straight line, it divides the arc of the quadrant also into two equal parts, each being equal to one-eighth of the whole circumference, or 45° (*A E F* and *F E B*, Fig. 18); if the right angles were divided into three equal parts by straight

lines, it would divide the arc containing 30° (*A E G*, *G E I*). The degrees of the circle are used by an angle of any number of degrees, by drawing an arc of a circle with any length of radius, and opening of the compasses in its vertex, to intercept a portion of the circle equal to the angle given. Thus the angle *A E H*,

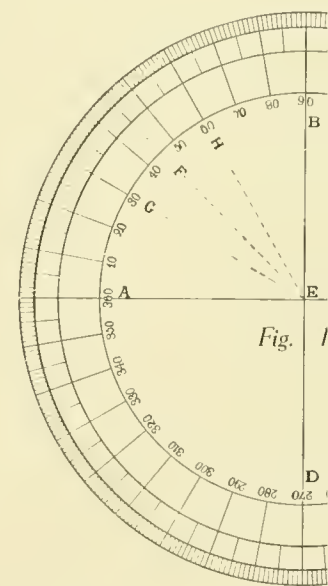

CONCAVE means hollowed out, or the interior of an arched surface is concave to convex. (Fig. 17.)

A **CONVEX** surface is one that is regularly protuberant or bulging. The opposite of convex is concave.

Divide Off Equally a Number of Parts on a Line, the Length of Which is Given

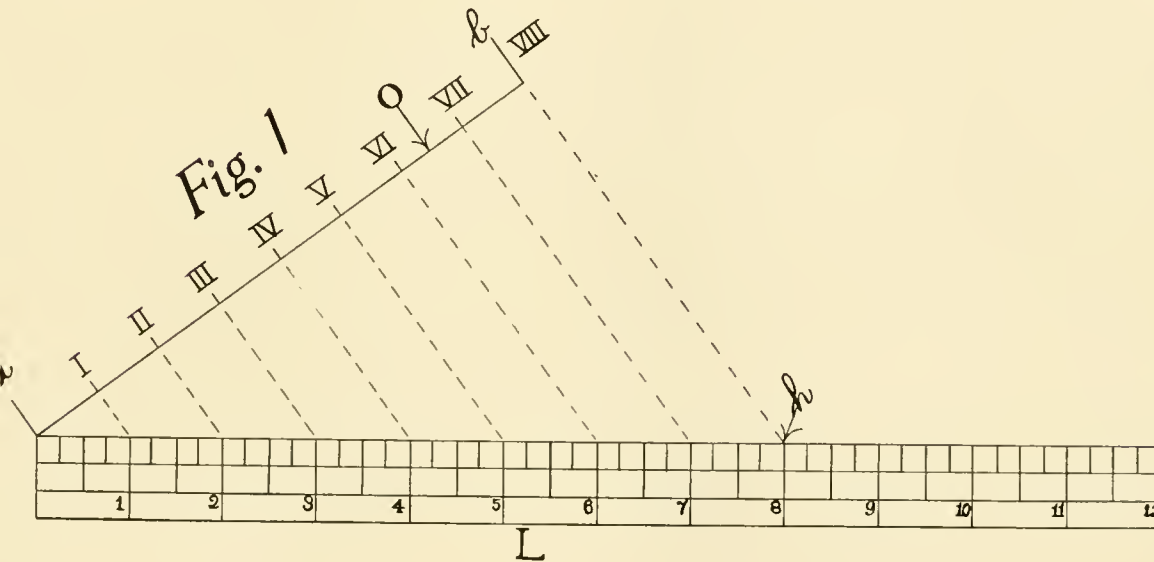

to divide a line $6\frac{1}{2}$ inches long into 7 parts. The easiest and quickest method is

Fig. 1. Draw a perpendicular line from a scale L from a until 8 inches strike

the perpendicular line drawn from line O at h . Mark each inch from the scale on to the drawing, and project on to line O , establishing points I, II, III, IV, V, VI and VII, which are equally spaced on line O .

The Laying Out of True Sweeps or Curves when the Amount of Sweep or Curve is Given

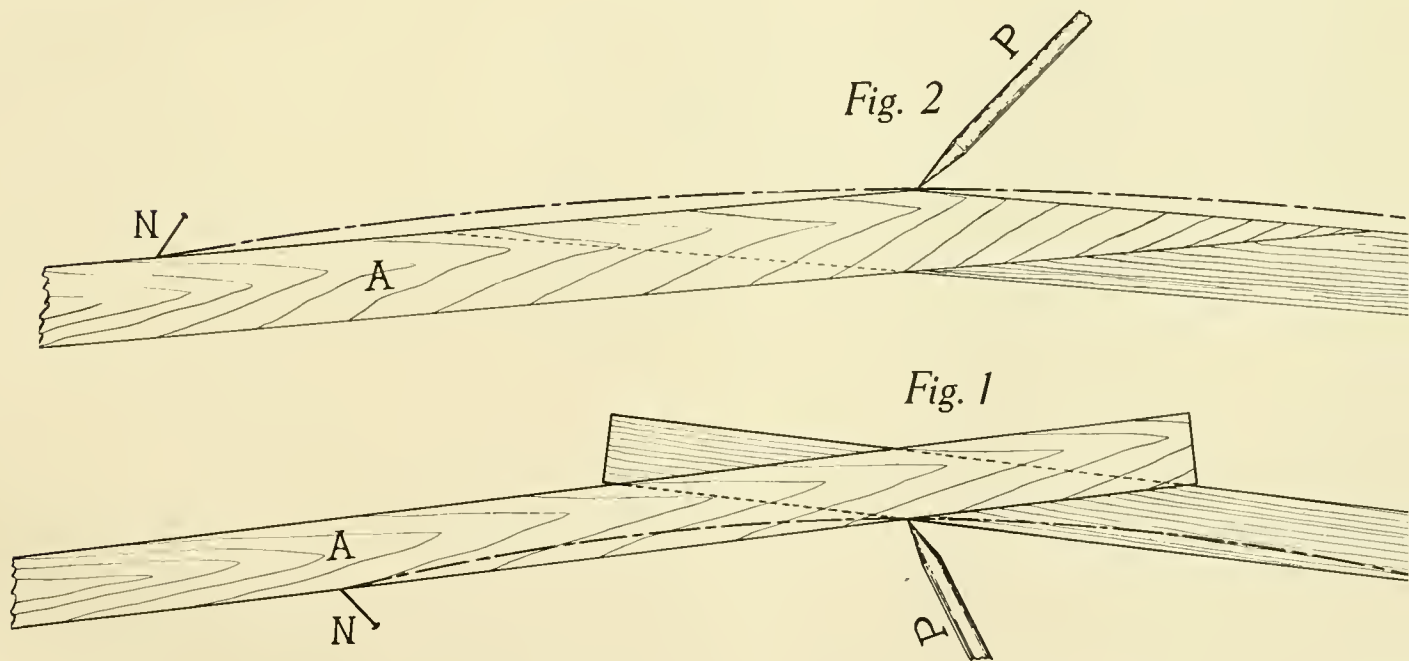

FOR laying out true sweeps or curves where it is impractical to strike the radius with the compasses or trammel points, we illustrate the following example, and although the principle has long been in use, it is unknown to a great many mechanics.

For the example let us say of 4 inches in a length of 40 inches line two points 40 inches apart, nail as illustrated in Fig. 1. Half lay out on a perpendicular line a

OF TRUE SWEEPS OR CURVES WHEN THE LENGTH AND AMOUNT OF SWEEP OR CURVE IS GIVEN—Continued

nt another nail. Next take two sticks, an the length of the sweep, and secure on the nails and forming a triangle, in Fig. 1 represent the sticks, and N

re placed tight up against the nails and that they cannot change their angle, and notch out the sticks at this point so may be placed therein.

weep, work the sticks back and forth in Fig. 1, being sure to have the sticks

In this way a sweep of any length his system will be found very convenient

in cases where the radius is too great to be reached by the compasses or trammel points.

It is usually customary to form the sticks as shown in Fig. 1, and place the pencil on the inside of the sticks as shown, but in some cases it is desirable to construct the sweep as shown in Fig. 2, with the outside of the sticks bearing against the edge of the nails, and the pencil being placed in the notch on the outside of the sticks. Although this is sometimes desirable, we believe it will be found more convenient to lay a sweep out as illustrated in Fig. 1, inasmuch as one need not be particular in fastening the sticks together, except that they must be fastened securely so that they will not change their position in relation to the nails.

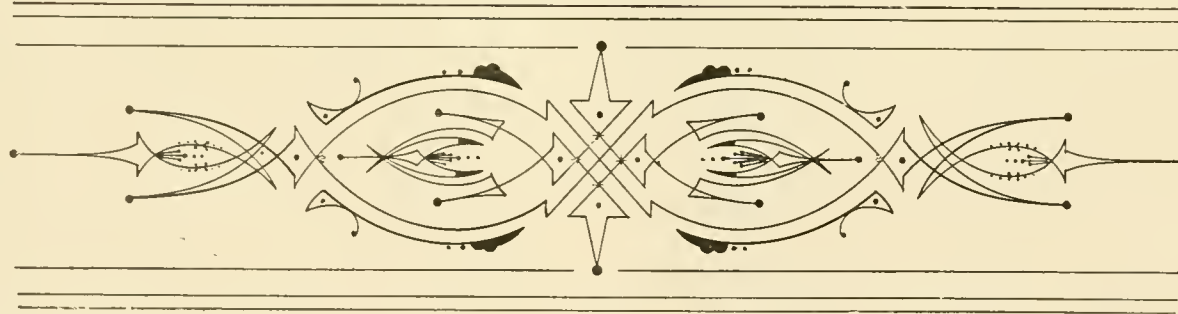

To Find the Radius of an Arc

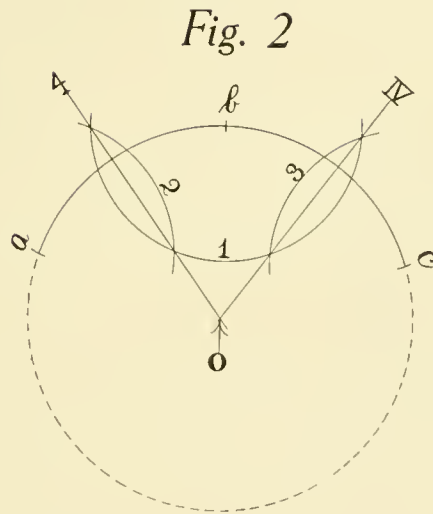

AN ARC FOR WHICH WE WISH TO FIND THE CENTER OR THE RADIUS.

REFER to a-c in Fig. 2, an arc for which we wish to find the center or the radius that described same. Take point b, which is midway between a and c, and describe arc 1 therefrom, the radius of which is greater than half the distance from a to b, or from b to c. With the same radius centered at a and c, describe arcs 2 and 3, passing through arc 1 described from b. Draw the lines 4 and IV through intersection of arcs, and where these lines intersect at O we will have established the center from which the large arc a-c was described.

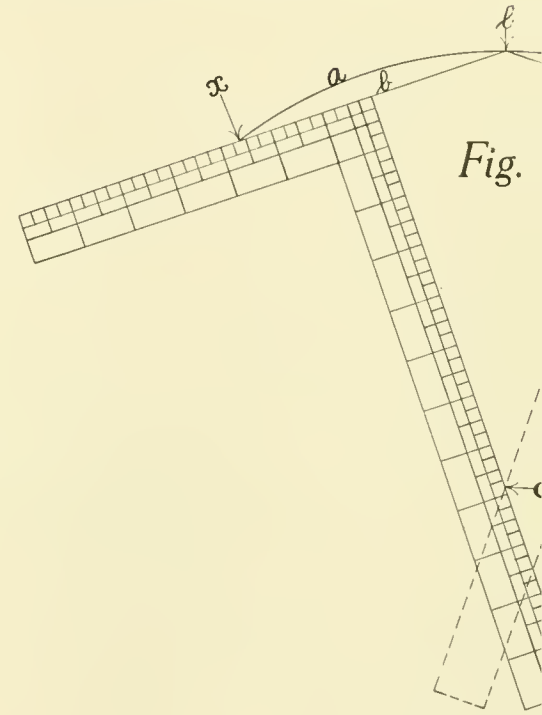

ANOTHER METHOD OF FINDING THE CENTER OF AN ARC.

Fig. 3 illustrates another method of finding the center of an arc by the use of a square. A square x-n is placed on the arc x-n which is at l. Draw a line from the center of the square x, l and n. Find the center of the square placed on line l-n, and draw a line from c. Then with the square placed on the arc, draw a line perpendicular from the center of the square to the line intersects that drawn from c and the center of the arc x-n.

Laying Out Ovals

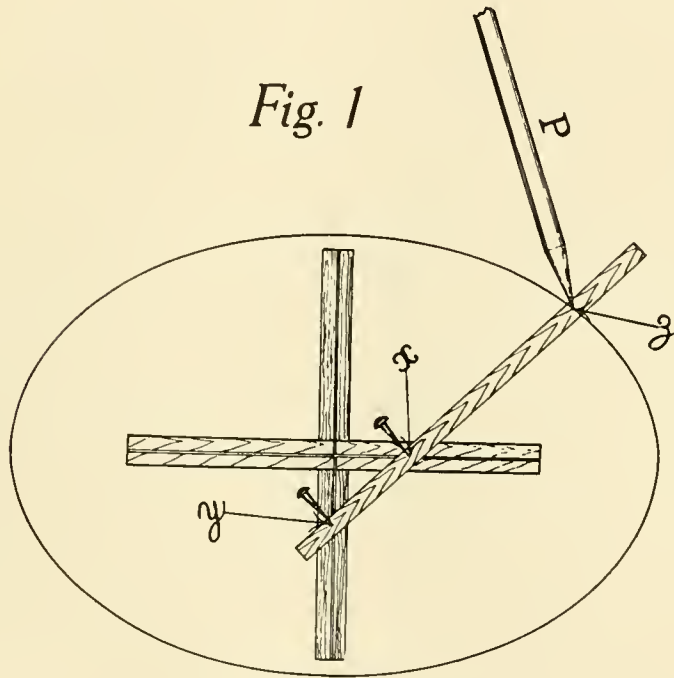

ONE SYSTEM FOR FINDING AN OVAL.

al systems for laying out a true oval, we will explain and illustrate three of them.

The first is illustrated in Figure 1. A square piece of wood, in the shape of a cross, and is grooved out as shown in Figure 1. The two adjustable pins or studs secured in the grooves are labeled *y-x*. Decide upon the length and width of the oval. Let the stick be 18 inches long and 9 inches wide. Lay out the center point on the stick one-half the width of the oval, that is, 4.5 inches, from *z* to *x*. Locate one of the pins in the groove at *y*. With one-half the length of the oval,

which would be 9 inches, lay same off on the stick from *z* to *y*. Set the adjusted pins into the grooves in the cross frame and work the same up and down, and back and forward on the frame, having the pencil point bearing on the paper and describing a true oval around the cross frame.

Figure 2 illustrates another method for laying out an oval, and when there are no instruments at hand, same will be found very convenient. Lay out the horizontal and vertical center lines of the oval, and on same lay out the length and width desired. Take one-half the length of the oval from *x* to *a* and lay this distance out from *c* until same strikes the horizontal

LAYING OUT OVALS—Continued

center line of the oval at e and h, at which points locate two pins or tacks, as illustrated. At point c locate another pin or tack, and around these three pins or tacks tie a piece of string taut, forming a triangle e-h-c. Remove the pin or tack at e, and put the point of a pencil in its place. Keeping the

of the oval. Draw another circle diameter of which will be equal Space off a number of points 1, A, and connect with the center of lines drawn from 1, 2 and 3 inters

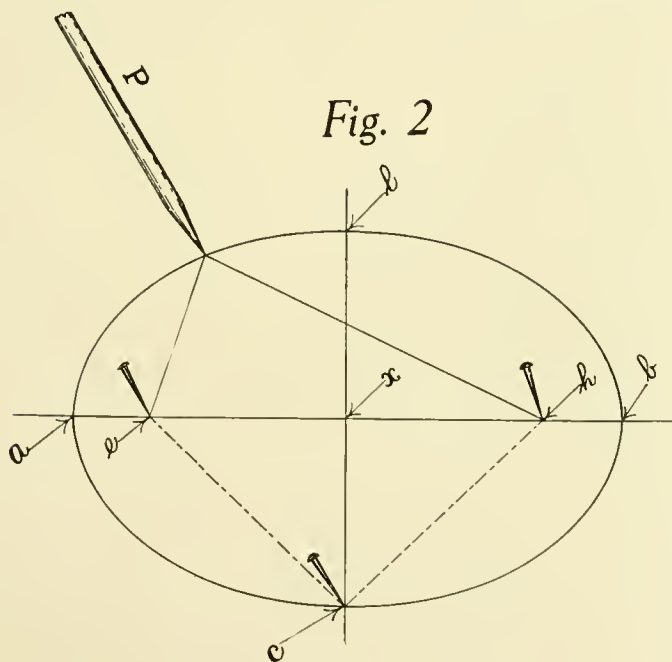

Fig. 2

ANOTHER SYSTEM FOR FINDING AN OVAL.

string taut, with the pencil back of same, work the pencil P around the pins, which operation will produce a true oval.

Fig. 3 shows another handy system for laying out a true oval. Draw the horizontal and vertical center lines of the oval, and determine the length and width. From O, the center of the oval, draw a circle B, the diameter equal to the width

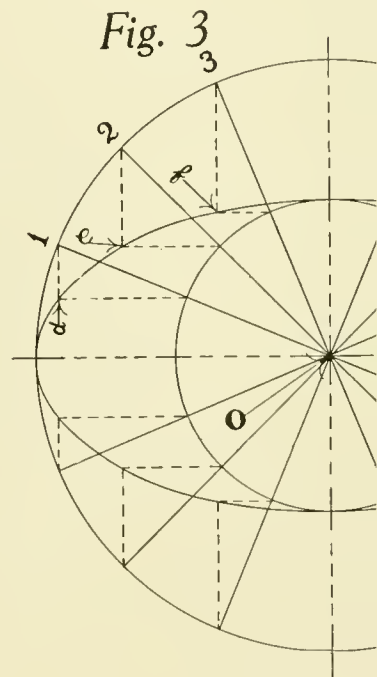

Fig. 3

LAYING OUT A TRUE

horizontal lines, outward, and from outer circle A, drop vertical projections. From the intersections of these vertical lines with the horizontal lines drawn from the inner circle, draw graceful sweeps. The same operations apply for both sides of the oval. After the four sweeps are drawn, they are finished with graceful sweeps which

Application of the Proportional Triangle for Laying Out Twisted or Winding Surfaces

This triangle will be used to a great extent in the following problems for laying out proportions of twisted or winding surfaces. In these advance problems will be found laying the student for some of the more difficult taken up in some of the following

Example in Fig. 1. The turn-under sweep B-Z is laid out from this line, providing we know the amount of turn-under, we may work proportional for any part of the body. B-Z being the assumed turn-under sweep, we desire to find out the correct turn-under sweep for another part of the body. The amount of turn-under is equal to the amount on line O-O, Fig. 1.

Line Z-X be drawn through the horizontal line O-O. A triangle BCX below line O-O. Point C is fixed on the assumed turn-under sweep. Point X is fixed on line Z-X as drawn from the top of the body. The base line O-O, and, in completing the construction we have to determine is X, and this is done primarily on the vertical line Z-X and to suit the body. We have point A also fixed by the over-all turn-under sweep which we wish to proportion, so we draw another triangle ACX, X being the common vertex of both triangles.

Now we have laid out a triangle for each turn-under, and it is by means of these triangles and the assumed turn-under sweep that we will develop the greater turn-under sweep A-Z. Passing through the assumed turn-under sweep B-Z and the vertical line Z-X, lay out a number of lines I, II and III at will above the horizontal line O-O. Where each one of these lines passes through the assumed turn-under sweep B-Z, take I for instance, drop a vertical line until we strike the hypotenuse for the proportional triangle of the assumed turn-under sweep. From this point draw a horizontal line passing through the triangles and number it 1. Where this line strikes the hypotenuse of the larger proportional triangle, erect a perpendicular line until line I is reached, thus establishing a point through which the correct proportional turn-under line A-Z must pass. Continue this operation with the remainder of the points, and connect with a graceful sweep, and we will have obtained a correct proportional turn-under, line A-Z, to the assumed turn-under, B-Z.

In Fig. 2 we illustrate another example which is equally important as that of Fig. 1. When a body is constructed with untwisted sides as far as the seat bottom, and in this illustration, Fig. 2, we will consider that the seat frame or the commencement of the twist is from line IV. B-Z is the assumed turn-under sweep. A-Y is the amount of turn-under at another part of the body for which we wish to proportion the turn-under sweep, having the same twist from the under

THE APPLICATION OF THE PROPORTIONAL TRIANGLE FOR LAYING OUT WINDING SURFACES—Continued

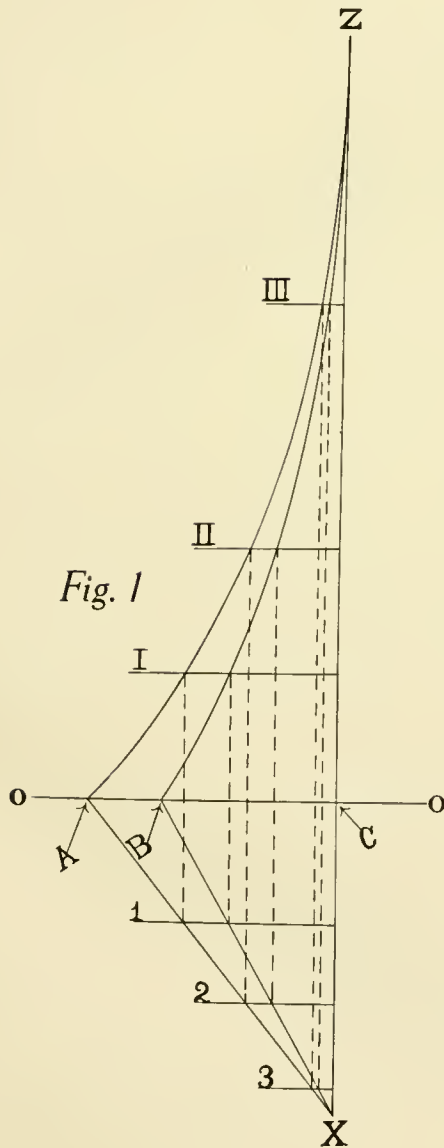

Fig. 1

side of the seat or line IV. Draw the straight line Z-X as a continuation of the body line before it commences to turn under at IV. It is on line Z-X that we locate the common apex X of our proportional triangles, which, as in Fig. 1, is determined at will. Lay out the proportional triangles BCX and ACX for the assumed turn-under sweep and the desired turn-under sweep, respectively. Space off a number of lines I, II, III and IV passing through the assumed turn-under sweep. Wherever these lines cut the assumed turn-under sweep, line B-Z, draw lines down on to the proportional triangle parallel with the outside line Z-X. Where these parallel lines strike line B-X of the triangle BXC, draw horizontal lines 1, 2 and 3 passing through the line A-X of the larger proportional triangle ACX. Project these points up and parallel to the outside line Z-X until lines I, II and III are intersected, thus establishing points through which the desired turn-under sweep will pass.

The only difference between this problem and that in Fig. 1 is that, instead of the usual vertical projections from the assumed turn-under sweep to the proportional triangles, the projections are parallel with the outside flared line Z-X. Fig. 2.



Construction of Joints

On this subject as we would like would require more space in this book than can be spared; therefore we will mention briefly the ordinary construction of the joints in body-making, and we believe that the reader will find of great value to the beginner, and a guide for further study in this very important

EDGED OR LAPPED JOINTS

The joint varies in shape and arrangement with the pieces united. A full lap is used when one piece overlaps the other to its full thickness; a half lap joint is cut away, whatever the shape of the joint. The common expression, "half-lapped," does not mean that the joint must be cut half away.

In the framing up of a toe bracket, each piece overlaps the other. In the sill and angle piece a rabbet is cut for the floor board, as shown by Fig. 2. In Fig. 2 is shown a batten or strainer joint with a feather-edge lap joint. As this is a simple piece of work to do other than that of framing up and supporting it, this kind of a joint is not so complicated. Fig. 3 illustrates a joint of a roof bow into the head rail of an enclosed car. Fig. 4 illustrates a section of a joint where the post half-lapped into the sill and top

rail. As an illustration of a full-lap joint we show the floor board let into a rabbet in the sill.

MORTISE AND TENON JOINT

Fig. 5 shows the two pieces to be united which form this joint. Note that they are both of the same thickness, and A is cut away equal on both sides for the tenon. The projecting part c on A, Fig. 5, is the tenon, and d in B is the mortise. e is the shoulder of the tenon, which is equal on both sides. f is usually one-third of the thickness of A and B.

BARE-FACED TENON AND MORTISE

In Fig. 6 we illustrate a bare-faced tenon and mortise joint. This means that the face of the tenon, or both faces, are exposed. The bare-faced tenon and mortise is used when two pieces are joined endways in the same direction, or endways in different directions, as shown in Fig. 6.

STUMP TENON.

Fig. 7 shows a mortise, tenon and stump joint, and is frequently used in framing up parts where certain joints should not be exposed as they are in Fig. 6. The stump reinforces and prevents twisting.

OPEN MORTISE, TENON AND MITER JOINT

This joint is illustrated in Fig. 8, and is used in framing up parts where it is undesirable to have the joints exposed.

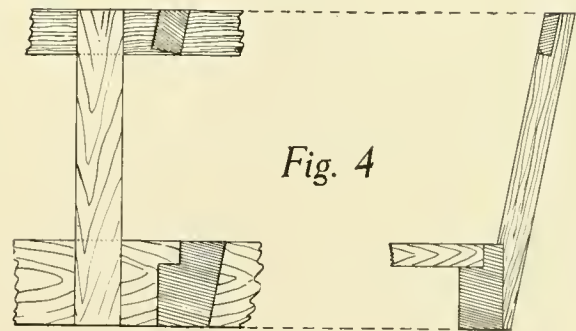
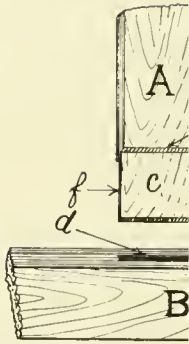
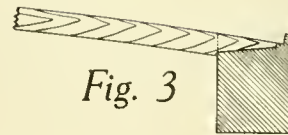
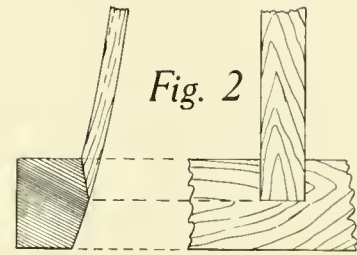
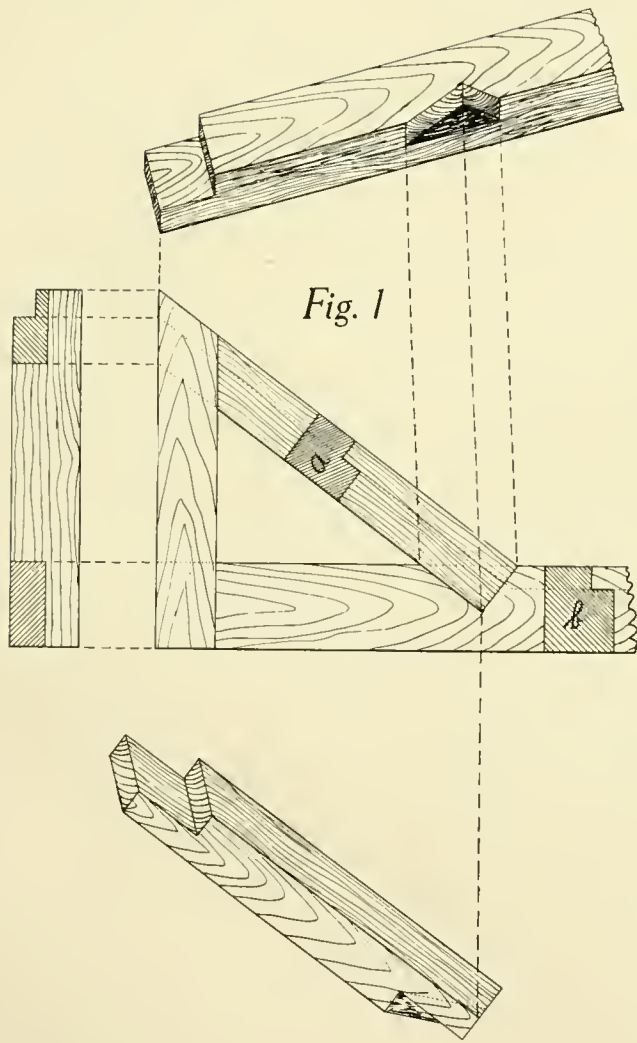

ILLUSTRATING THE CONSTRUCTION OF JOINTS.

CONSTRUCTION OF JOINTS—Continued

TRUE TENON AND MORTISE

A true tenon and mortise joint is illustrated in Fig. 9, showing the fence bar a into the door pillar b. It makes a stronger joint than with a single mortise. It replaces a single mortise and tenon joint is also illustrated in Fig. 9, the lock set into the pillar b.

FALSE TENON

A false tenon for joining a frame, as in the case a false tenon is used on account of its being not as satisfactory as a bare-faced tenon. In framing up parts with a false tenon, care should be taken to have the grain of the tenon cross that of the parts united.

MITER JOINT.

This is a simple 45-degree miter joint. This is

STUMP TENON AND LAP JOINT.

This illustrates a stump tenon and lap joint, which is stronger than the half-lap, and is frequently used in the construction of sills and pillars.

BASTARD TENON

This joint is shown in Fig. 13 in the framing of a post into a sill and where exposed joints are undesirable. It will be seen that the half-lap joint would show two long joints, while a mortise and tenon joint would be impractical inasmuch as the tenon would be too close to the outer surface.

Fig. 14 illustrates dovetail joints. Figs. 15 and 16 show ordinary splice joints. Fig. 17 illustrates a method for securing metal panels to body framing, and by this method we do away with exposed screw heads and nails, the metal panel being turned around a $\frac{1}{4}$ " x 1" flat iron which is let into a rabbet flush with the standing pillar. This is secured by means of machine screws from the inside of the post which are covered up by the trimming.

Fig. 18 illustrates a method for securing the upper panels, above the belt, of a limousine body. Note that this upper panel is offset from the lower panel, and that the belt rail is rabbeted out to receive an iron plate and around which is formed the upper metal panel. The lower panel also comes up back of this iron, forming a tight joint, the iron being secured by means of machine screws from the inside of the belt rail, as illustrated. This upper offset panel is generally made of wood, but this construction eliminates the troubles incident to wood panel construction, over which the metal panel has the advantage.

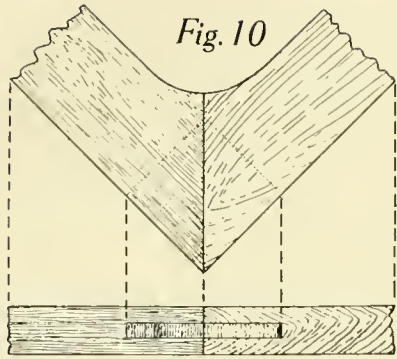

Fig. 10

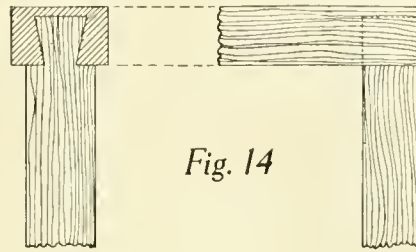

Fig. 14

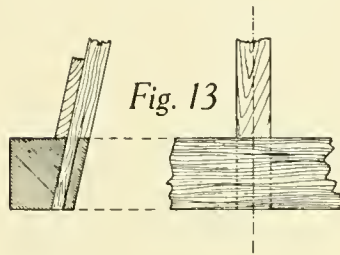
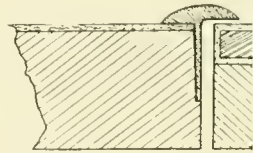

Fig. 13

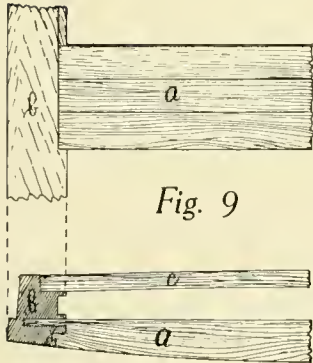

Fig. 9

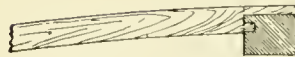

Fig. 12

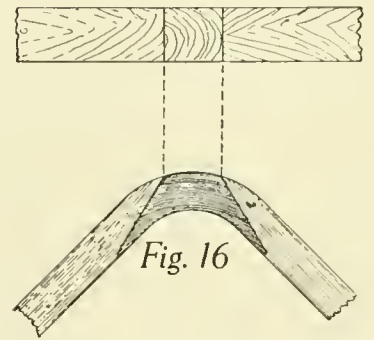

Fig. 16

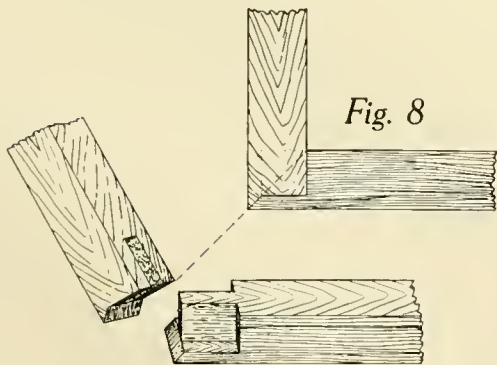

Fig. 8

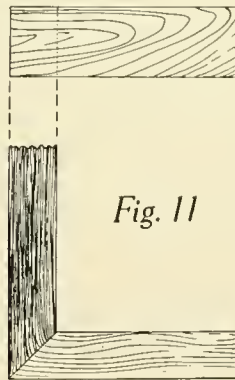

Fig. 11

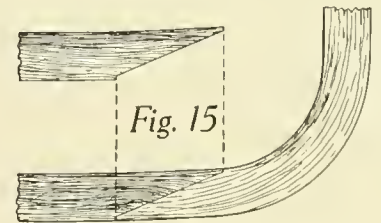

Fig. 15

How to Lay Out a Proportional Corner by the Use of Proportional Triangles

profile or side view of an automobile seat. Lay out the horizontal line EC from the extreme height of the seat. This is not necessary, but is necessary in laying out the

corner in Fig. 2 it is necessary to assume a center point around the seat, or the bottom line. In this case lay out the line EC, Fig. 2.

Construct the proportional triangle FOB. BF is the level squared down to the bottom of the seat. The apex O should be located on the horizontal line EC, Fig. 2.

Construct the proportional triangle EQA, Fig. 2. EQ is the side bevel or flare taken from Fig. 3. Q is the apex of the triangle, and should be located on the horizontal line EC. The line AQ of the proportional triangle, Fig. 2, is the same as OB of the triangle on Fig. 1.

On line EC, Fig. 2, lay out horizontal proportions 1, 2, 3, 4, 5, 6, 7 and 8 around the corner. From each point up to the outside line of triangle EQA, Fig. 2, square point ahead until it strikes inner line of triangle EQA, Fig. 2, at k. From this point drop a perpendicular line on to inner line of triangle EQA, Fig. 2.

On line EC, Fig. 2, lay out horizontal proportions 1, 2, 3, 4, 5, 6, 7 and 8 around the corner. From each point up to the outside line of triangle EQA, Fig. 2, square point ahead until it strikes inner line of triangle EQA, Fig. 2, at k. From this point drop a perpendicular line on to inner line of triangle EQA, Fig. 2.

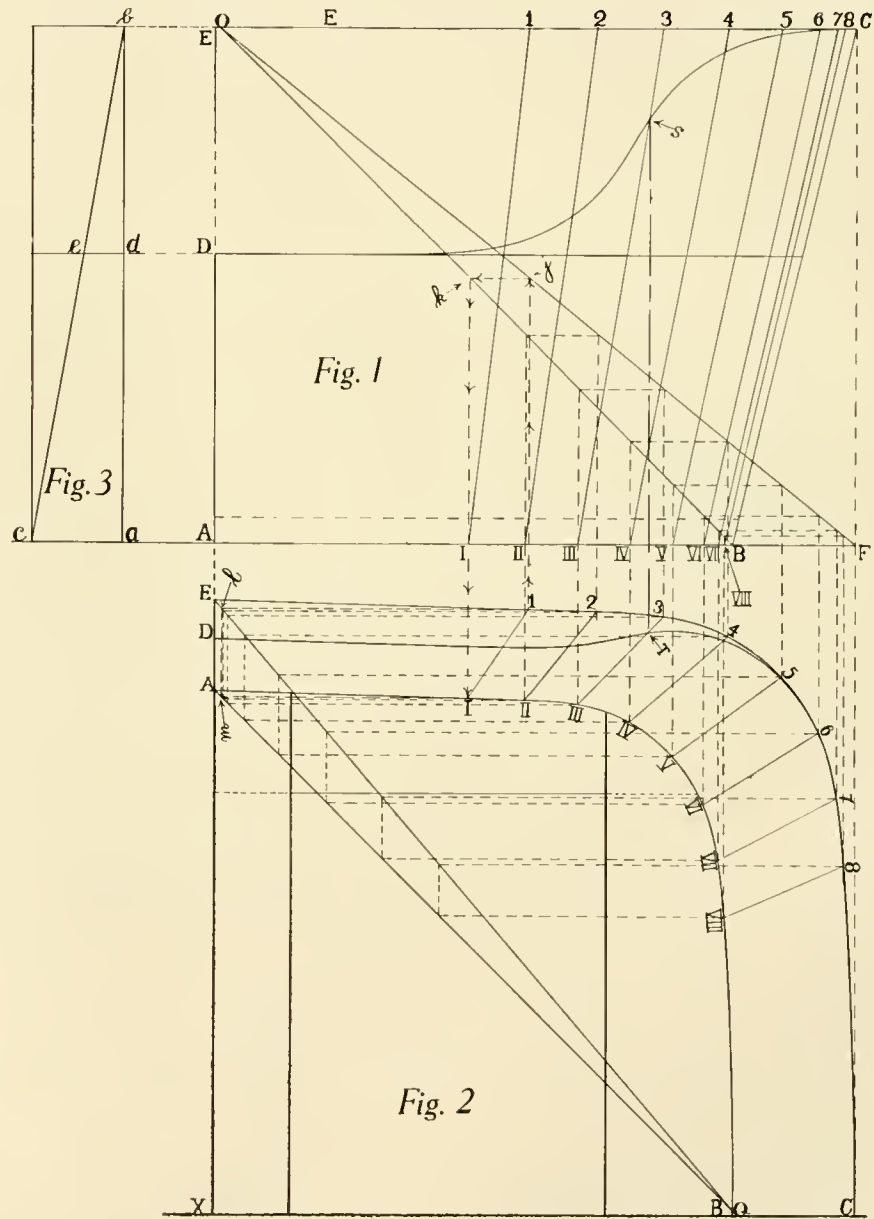

SIDE VIEW, ONE-HALF BOTTOM VIEW AND SIDE BEVEL AND FLARE OF AN AUTOMOBILE SEAT.

LAYING OUT A PROPORTIONAL CORNER BY THE USE OF PROPORTIONAL TRI

at m. From m draw a horizontal line back until it intersects vertical line drawn from k, Fig. 1, thus establishing the point I which is proportional to point 1 on line EC, Fig. 2. Continue this operation with 2, 3, 4, 5 and 6, etc., and we will have obtained points on the seat frame through which the bottom line AB in Fig. 2 must pass.

In order to lay out arm rail, 6 to D on Fig. 2, proceed as follows:

Connect points 1, 2, 3, 4, 5 and 6 on line EC, Fig. 2, and corresponding points on line AB with straight lines. Project these same lines and points on to Fig. 1. Wherever the arm rail line cuts these lines, take s for an example, Fig. 1,

square this point down until it intersects vertical line drawn from k, Fig. 2 at T. Repeating this operation with other intersections will produce the points on the arm rail line which the arm rail line should pass.

D shows the amount of side arm rail on line ed, Fig. 3. This method can be applied for obtaining any irregular lines AB and EC, provided the figure is all around. Do not attempt to use this method if the turn-under is either concave or convex. A proportional scale as explained at the end of this book.

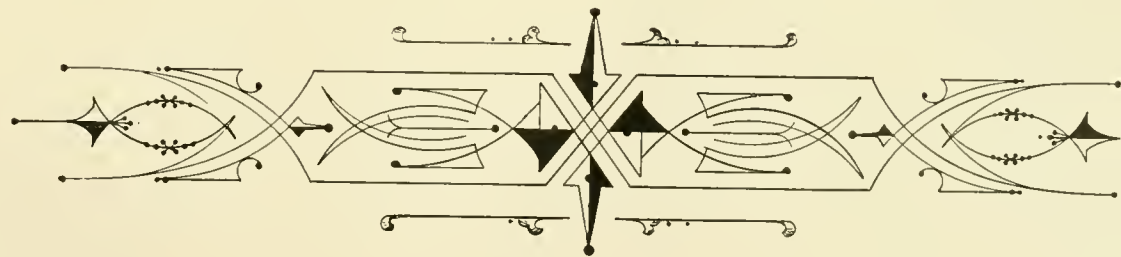

Working Out of Proportional Corners by the Use of Parallel Lines and Intersections

We will illustrate and explain another system of laying out proportional corners of seats, etc. This is in connection with the problem taken up in the preceding chapter, laying out proportional corners, but is a different method which is used a great deal, and we will select whichever is most convenient. In this system we have adopted this system throughout the book as it is the handier of the two.

It is necessary to draw out the seat in the profile view from the partly imaginary line a-O drawn horizontally to the extreme height of the seat or body. In Fig. 1, assume either the bottom seat line d-D, or the top line a-A taken from the horizontal line a-O, or the top line of the seat in Fig. 1. In this problem we will draw out the top line around the seat a-A to the height of this line in Fig. 3, after we have obtained the top line in Fig. 2 and the flare of the back in Fig. 1, and transfer to Fig. 3, we will obtain the proportional corners and intermediate sections.

From point 6 around the seat, a-A in Fig. 3, lay out the points, namely, 1, 2, 3, 4 and 5, same being located at the height of the corner. With the use of these points we are to obtain points corresponding to these points on the seat, Fig. 3, through which the same line should pass. From point 6 on the center line of the

seat in Fig. 3 draw a straight line connecting with point 5 on the top line of the seat, and parallel to this line from point VI draw another line extending indefinitely through the seat.

From point A on the partly imaginary line a-A in Fig. 3 draw a straight line, and connect same with point 5 on line a-A, and parallel to this line draw another line from D on the front of the seat at the bottom until same line intersects the line drawn from VI at V.

From each of the remaining points, 1, 2, 3 and 4, on the top line of the seat a-A, Fig. 3, draw lines to points 6 and A on line a-A, and parallel to these draw lines from VI, and from D until lines drawn from D intersect those drawn from VI at I, II, III and IV. This establishes proportionally points through which the bottom line of the seat d-D should pass.

Now that we have the top and bottom lines of the seat, it is essential to prick off the arm rail line in Fig. 3, which is accomplished as follows:

Project from Fig. 3 to Fig. 1 on to their relative positions lines 1-I, 2-II, 3-III, 4-IV and 5-V. Wherever the arm rail line passes through these oblique lines in Fig. 1 drop vertical projections until same strikes corresponding oblique lines in Fig. 3, thus establishing points through which the arm rail line shall pass. Take the amount of flare at the front of the seat and the height of the side in Fig. 2 and transfer from D to B

in Fig. 3. Draw graceful line passing through the points already obtained, and same will produce the arm rail line in Fig. 3.

Now, we are supposing that the construction of this seat calls for a belt moulding or rail around the seat at the height of e-C in Fig. 1. We wish to produce this line around the seat in Fig. 3, and to accomplish same we will take points where line e-C in Fig. 1 passes through the oblique lines 1, 2, 3, 4 and 5 and project these points down on the corresponding oblique lines 1, 2, 3, 4 and 5 in Fig. 3. Take the amount of flare at the height of C from Fig. 2, and lay same out in its correct position from D to C on the front line of the seat in Fig. 3. Also take the amount of flare at the height of e from the back of the seat in Fig. 1, and transfer from d to e on the center line of the seat in Fig. 3. Connect these points with the points already obtained on lines 1, 2, 3, 4 and 5 in Fig. 3, and we will have produced line e-C in Fig. 3, corresponding to line e-C in Fig. 1, which is proportional with top and bottom sweeps of the seat in Fig. 3.

Likewise any point on the bottom view of the seat in Fig. 1 can be obtained in the same manner, the system being that of projection.

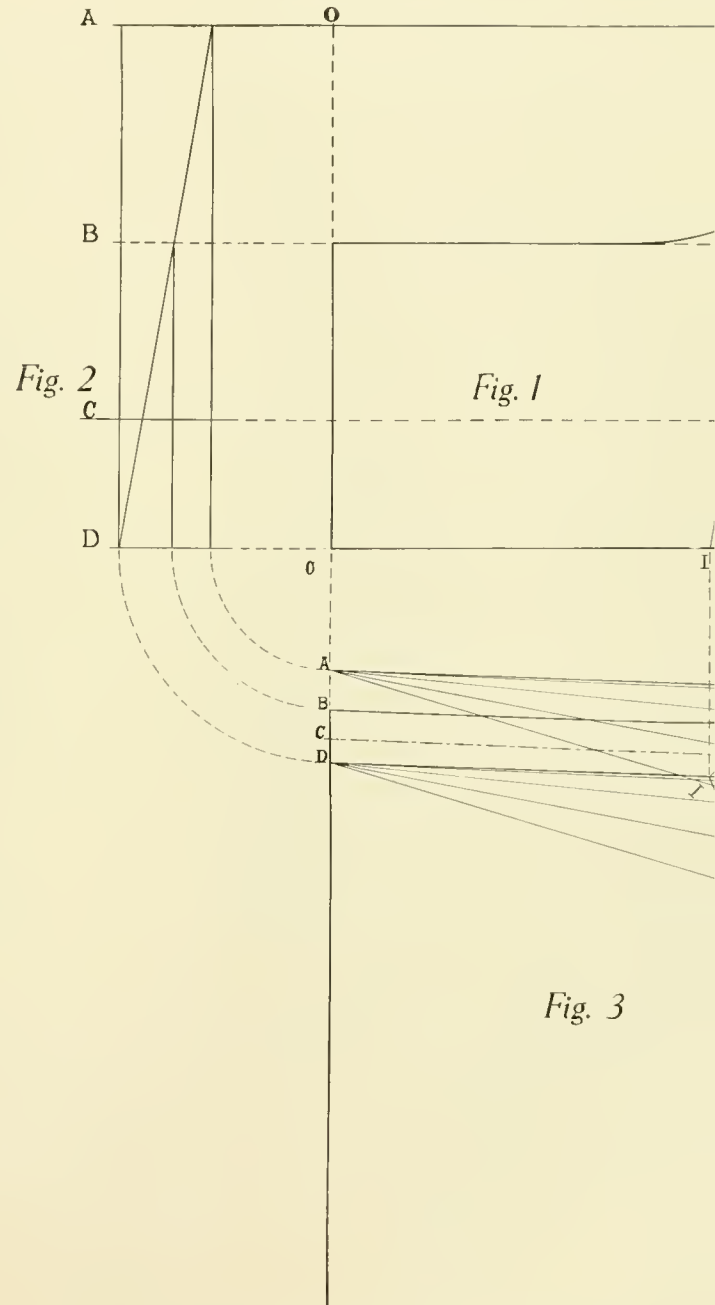

Out Seat Panels, the Dihedral Angle of a Corner Block, and Mitters of a Wagon Seat

Fig. 2 represent the side elevation and one-elevation, respectively, of a wagon seat. Line *bc* represents the back flare; line *bc* in Fig. 2 represents the back flare. In order to lay out the exact size of the seat panels as follows:

From point *b* in Fig. 2, describe an arc passing the vertical line at *II*. Project point *c* in Fig. 1 until it strikes the vertical line *F* at point *E*. Connect *E* and *C*, Fig. 1, gives us the exact flare of the back panel. Lay out a line *DC* parallel to the back panel *dc*, Fig. 1, until it strikes the vertical line at *D*. Connect points *D* and *a*, Fig. 1, gives us the front line of the seat panel. Dash lines connecting *a*, *D*, *C* and *b*, Fig. 1, give the size of the stock for the side panel.

To find the size of the stock for the back panel, set the compass at point *c*, Fig. 1 and describe an arc from *c*, striking the vertical line at *L*. Square this point on to vertical line *b*, Fig. 2, as shown by dot and dash line. Lay out the top line of the panel parallel to line *bc*, Fig. 2, the size and shape of the stock for the back panel.

To find the size of the seat panels, it is desirable to find the dihedral angle or corner block bevel. From

point *III*, which is taken arbitrarily, on the line of the stock, Fig. 1, draw a line perpendicular to the line of the stock *bC*, Fig. 1, until it strikes the base line at *V*. From the line of the stock for the back panel, *bC* in Fig. 2, square a line from point *II* down to the base line at *I*. Point *II*, Fig. 2, is a horizontal projection from *III*, Fig. 1.

The next operation is to draw a line perpendicular with the base from point *b* in Fig. 2. Take the distance from *V*, Fig. 2, to *b*, Fig. 1, and lay same off from *b* to *V* on the vertical line in Fig. 2. Take the distance from point *V*, Fig. 2, to *III*, Fig. 1, and as a radius describe arc *VI* from point *V* on the vertical line *b*. Next describe an arc from point *I*, Fig. 1, with a radius equal to the line from *I*, Fig. 1, to *II*, Fig. 2, this arc *VII* intersecting arc *VI* at *Z*.

Now the dihedral angle or corner block bevel will be taken from the angle *IZV*. In order to find the bevel of the mitres for the seat panels, simply take the corner block bevel and bisect same as illustrated in Fig. 4.

For further explanation, the dot and dash lines in Figs. 1 and 2 indicate the shape and size of the seat panels or stock when laid flat, marked by *S*, Figs. 1 and 2. In Fig. 3 the corner block *B* is illustrated, and should be planed up with the bevel as taken from *IZV*.

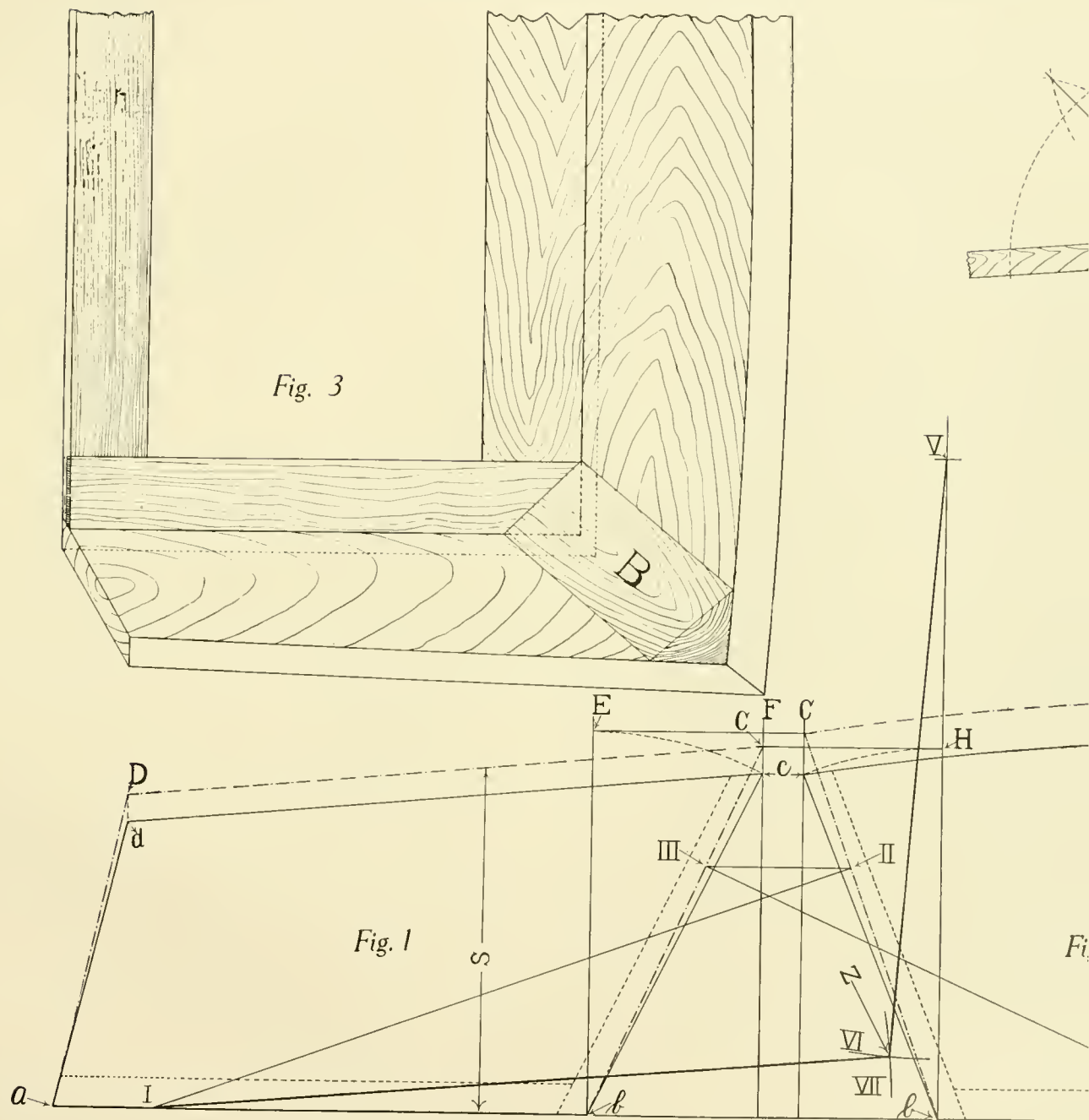

LAYING OUT SEAT PANELS AND FINDING THE DIHEDRAL ANGLE.

Framing Up of Bodies Having Contracted and Flared Sides

We illustrate two problems, Figs. 1 and 2, in portions of seat framing showing an angle or sail framed into a seat frame and top rail. The object is to show how to obtain the bevels of angle or sail that should be given the post when it stands in its correct position when set up around and flare.

Fig. 1 illustrates a post standing square in the vertical plane A, side view, A, Fig. 1, the post cannot be framed up with the contracted lines of the seat frame unless the bevel must be set at a certain angle, so that when the post is flared it will stand square or plumb in the vertical plane A. The amount of contraction and flare determine the bevel that should be given to the joints of the post to stand square in the vertical plane A. The required bevel of the joints or angle of contraction follows:

From the side view A, having the post square in the vertical plane A, draw the base line. Determine the amount of contraction and lay out on the end view B, and on the side view A, the amount of contraction desired. From the top view B, draw the angle of the post where it intersects the top rail at I, draw a line perpendicular with the top rail until it strikes the bottom line of the seat at III. From point II, where the back edge of the post intersects the bottom edge of the seat frame, to III on the

bottom view C, and transfer from II forward to III on the bottom line of the seat in the side view A. Draw a straight line passing through I and III which will establish the angle or sail on which the post must be framed up in order to have it stand square or plumb in the vertical plane A after it is swung around on the contraction and flare.

Fig. 2 illustrates a similar example, the only difference being that the post is set up on an angle or sail in the vertical plane A. In framing the post into the top rail and seat frame the bevels for the joints must not be taken directly from the side view A, but should be determined by means of the following system:

From the contraction line b-d on the bottom view C, square a line from the intersection of the back edge of the post with the top of the top rail at I until it strikes the bottom of the seat frame a-e at IV. From point I on the bottom view draw a line square across the body, intersecting the bottom of the seat frame line at III. Take the distance from III to IV on line a-e in the bottom view C, and lay same out on the bottom line of the seat in the side view A from the back of the post II forward to III. Connect III and I with a straight line, thus establishing the angle or sail on which the post must be framed up in order to have it conform, after it is swung around on the contraction, to the angle or sail shown in the vertical plane A. This line also establishes the bevel on which the shoulders for the joints should be cut.

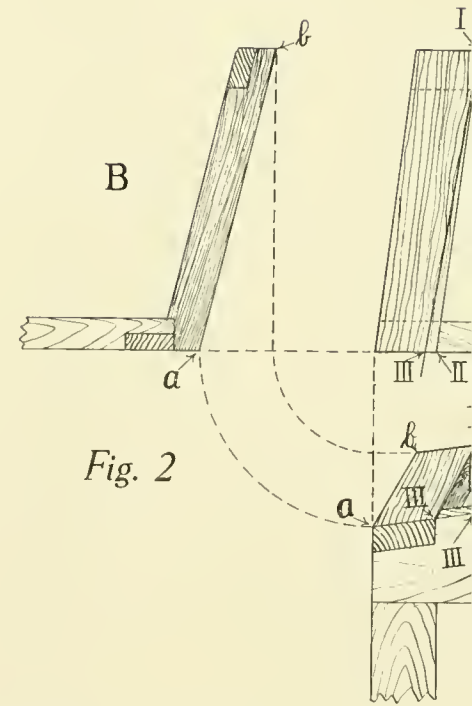
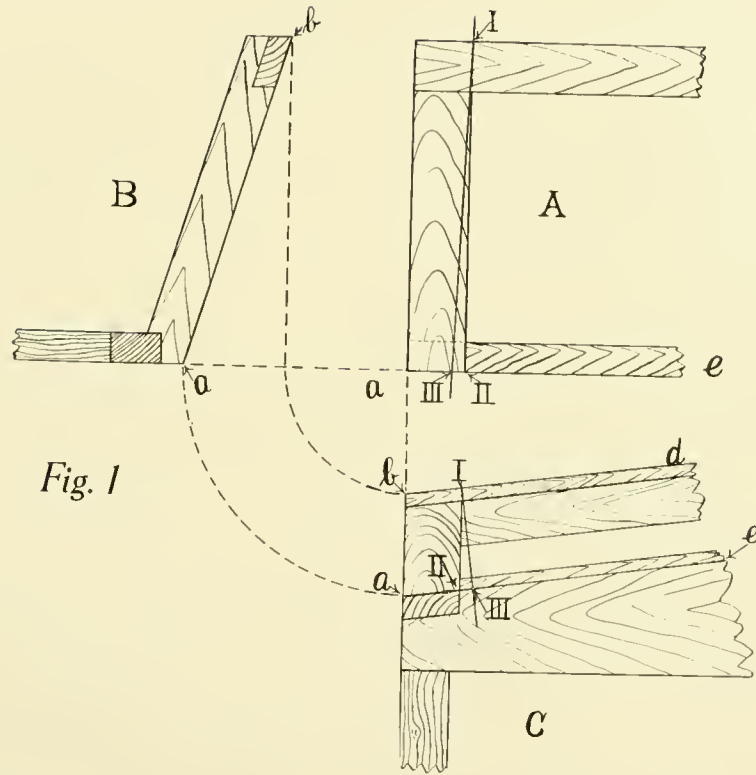

REPRESENTING PORTIONS OF SEAT FRAMING.

Proportional Corner and Laying Out of Horizontal Sections and Corner Strainers on a Torpedo Body

s are illustrated on the rear of a torpedo
 et us explain the position of the propor-
 Referring to page 24, we will find the
 taining the bottom line around the corner
 p line is assumed.

will be noted that the proportioning
 ne front of the seat on the side, and the
 t the rear. The points from which the
 s regulate the size of the corner some-
 This, of course, is a matter of taste. If
 corner at the bottom, he may work the
 5, but the method we introduce in this
 ry satisfactory, and we recommend it on
 As will be noted, it gives a smaller corner
 er the side view or profile of the body is
 , the width from the center line to Z in
 -under, Fig. 3 should be laid out on the

on is to assume the line Z-Y, Fig. 2, taken
 Fig. 1, and Y-Z, Fig. 4, but care should
 a smooth and graceful line around the

pp corner sweep forms tangents to the
 s, as at f and e, Fig. 2, draw horizontal
 ectively, until they intersect at H, Fig. 2.
 Fig. 2, up until it strikes the horizontal

line Z-Y, Fig. 1, and from this point draw a straight line
 parallel to t until it strikes base line X-T at g. Square this
 point down to the side sweep, Fig. 2 at g, and this gives us the
 commencing of the proportional corner on the side.

To find out where to commence the proportional corner
 at the rear, lay out points A and g, Fig. 4, which correspond
 to A-g, Fig. 2. Connect these points on Fig. 4 with a
 straight line.

From e on the horizontal line Y-Z, Fig. 4, which is taken
 from center line to e, Fig. 2, draw a line at any convenient
 angle, say 45 degrees, until it strikes straight line connecting
 A and g at j, Fig. 4, from which draw a horizontal line until
 it strikes center line of rear view at i. Connect i and e, and
 we will have completed a triangle e-i-j.

Draw another triangle mkl, Fig. 4, with the sides parallel
 to those of the triangle e-i-j, Fig. 4. At any convenient point,
 l for example, which is located on straight line passing through
 A-g in Fig. 4, draw a line parallel to e-j. From point k on
 center line of rear view, which is a horizontal projection from
 l, draw a line parallel to i-e, and these two lines intersecting at
 m form the second triangle, mkl, Fig. 4.

Connect the apexes e and m of the triangles with a straight
 line, and the point where same cuts the horizontal base line
 T-X at h, Fig. 4, gives us the point h on Fig. 2, from which
 draw a horizontal line until it cuts the back top sweep at M.

Now we have on Fig. 2 points A, g and M, h, from which

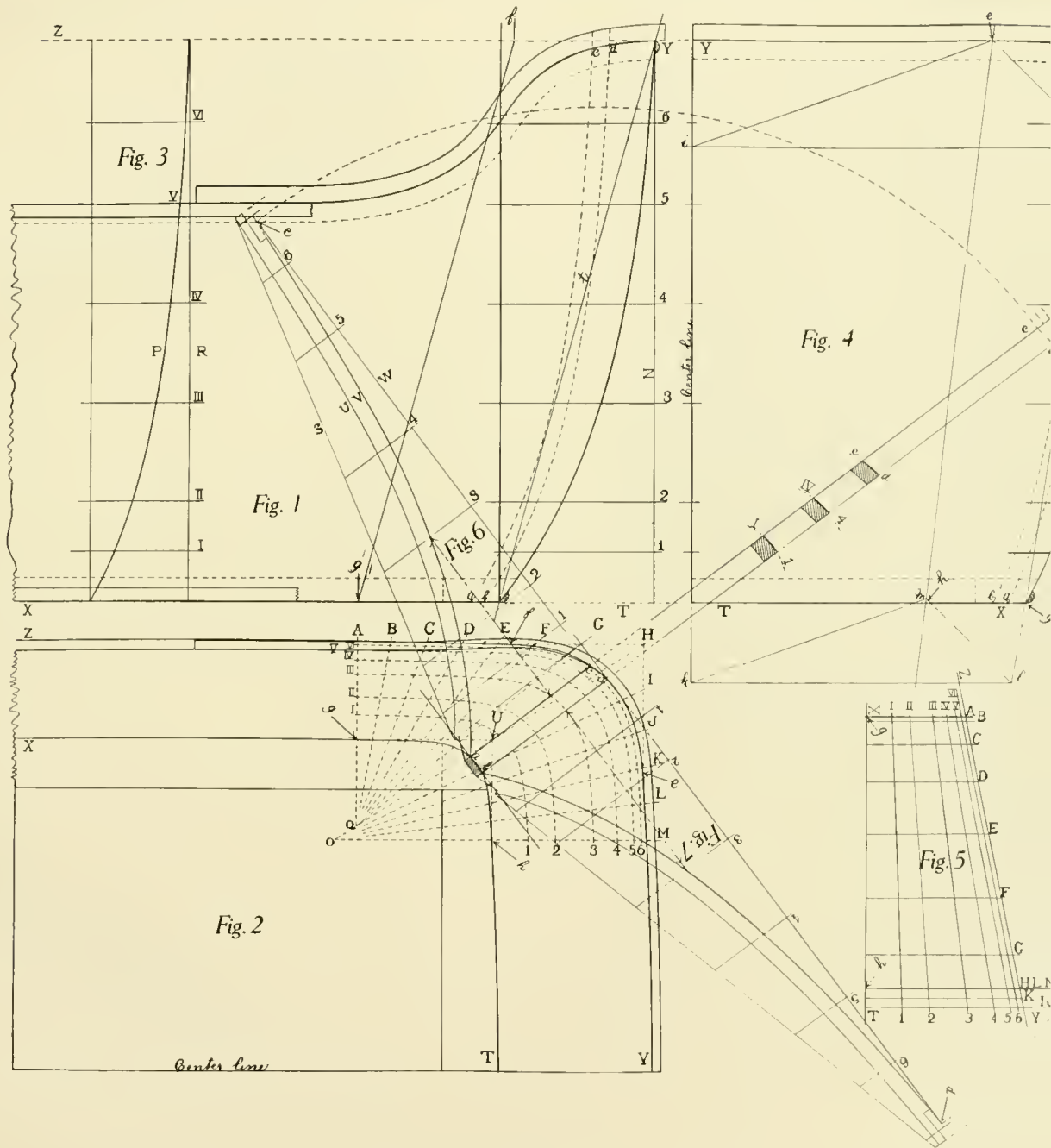

ILLUSTRATING THE PROPORTIONAL CORNER, HORIZONTAL SECTIONS AND CORNER STRAIGHT

PROPORTIONAL CORNER AND LAYING OUT OF HORIZONTAL SECTIONS AND CORNER STRAINERS ON A TORPEDO BODY—Continued

from the top line the points necessary to define the corner, as in problem on page 25. Finished, continue the bottom side sweep X-g, Fig. 2. Also lay out the bottom rear sweep M-Y.

Necessary to have sections of the corner at between the top and bottom lines of the seat to make the necessary forms to enable us to get shape of the seat or body at a given point

Draw vertical lines from g and h, respectively, intersect at U, Fig. 2. Draw a straight line through M and h and a horizontal line through M and h at O, Fig. 2.

Choose convenient number of points around the corner on line Z-Y, Fig. 2, as B, C, D, E, F, G,

between H and M only, Fig. 2, draw straight lines until they converge at O, as from I to O.

Through A and g a line intersecting line MO. Connect points B, C, D, E, F, G, between M and O at Q.

Draw sections of sections of the body in Figs. 1, 2, as desired, as, for example, sections 1, 2,

Take the amount of turn-under at each of these sections from the side turn-under at Fig. 3 and the back turn-under at Fig. 1, and transfer same on to the lines AQ and MO, respectively, Fig. 2. For example, take the turn-under at III, Fig. 3, from the square line R, to convex turn-under line P, and lay it out from point A to III on line AQ, Fig. 2, and so on.

On Fig. 5 is laid out the proportional scale used in finding the sections around the corner between Ag and Mh, Fig. 2. Let X-T, Fig. 5, represent the base line or X-T on Fig. 2. From line X-T, Fig. 5, first lay out the side turn-under of the body, g to A, taking same from g to A, Fig. 2.

At any convenient distance from gA, Fig. 5, lay out the amount of rear turn-under, h to M, from line X-T. Draw a straight line through A-M; likewise lay out sections 1, 2, 3, 4, 5 and 6 on side and back turn-unders, Fig. 5, as taken from Figs. 1 and 3, and connect with straight lines.

Transfer the turn-unders between lines Z-Y and X-T, Fig. 2, at B, C, D, E, F, G, H, I, J, K and L, laying same out on proportional scale from line X-T until they strike line Z-Y, Fig. 5. As the greatest amount of turn-under on this corner is between A and M, Fig. 2, we have to extend lines X-T and Z-Y beyond M on the proportional scale, Fig. 5.

Having the proportional scale complete, it only remains to lay off the different turn-unders, 1, 2, 3, 4, 5 and 6, at B, C, D, E, F, G, H, I, J, K and L from the scale on to the corresponding points of Fig. 2.

POSITION OF PROPORTIONAL CORNER AND LAYING OUT OF HORIZONTAL SECTION STRAINERS ON A TORPEDO BODY—Continued

This much accomplished we will connect the points between Z-Y and X-T on lines B, C, D, E, F, G, H, I, J, K and L, Fig. 2, and we will have the desired sections of the corner at the heights of 1, 2, 3, 4, 5 and 6, Figs. 1 and 4.

On most bodies of the type illustrated here, the construction calls for a strainer set up and framed into the sill at the corner, as shown in Fig. 2. This strainer should be set up square from the bottom, that is, square from a straight line passing through the intersections of the outer edges of the strainer and corner at the bottom, in order to obviate as much as possible the necessity of beveling the strainer. In this problem we illustrate a very simple method for laying out the full size of the strainer at the front and back sides.

First let us lay out the strainer on the corner of the body, Fig. 2, wherever it may be desired. Take the width of the strainer and lay it out on line X-T at ab, Fig. 2. From a straight line passing through these points, square front and back lines of the strainer through sections 1, 2, 3, 4, 5 and 6 until they cut line Z-Y at cd, this being the top of the strainer in Fig. 2.

Having determined the front strainer on Fig. 2, proceed to lay s Figs. 6 and 7. Let us lay out a str to the front face a-e of the strainer line should be equal in height to line

At right angles to this line, dra taken at the heights of these lines c sections 1, 2, 3, 4, 5, 6 in Fig. 2 i strainer, square points on to lines 1. Connect these points and it will give line V of the strainer. For the ins the thickness of strainer from line S, Fig. 6, shows the line of the steel would be cut.

The same operation is applied back side of the strainer, Fig. 7, ex be squared from the back side of st I-1, IV-4 and e-d are sections of corresponding lines on Figs. 1, 2 an

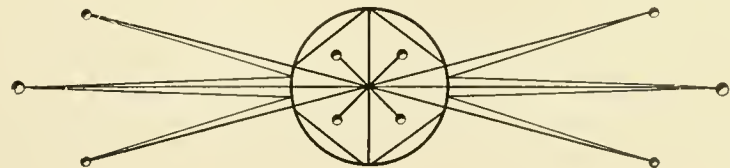

Laying Out of Twisted or Winding Surfaces, Illustrated on a Torpedo Body

PRODUCE in this problem the application of a accurate method for laying out twisted surfaces on the side of a torpedo body. Proportional horizontal and turn-under sections are obtained so that after the body is constructed possess harmonious and symmetrical lines. As in the illustration of this body there is a dash in the rear corner to the dash, Fig. 2. In the turn-under sweeps at each of the standing pillars, Fig. 1, it is necessary to obtain horizontal sections of the body at 3, 4 and 5, Fig. 1. (First the sections are laid out complete as possible, independently of the turn-under sections 3, 4 and 5. The top line 2 at the waist and the bottom line 6 should be laid out in Fig. 2.)

Fig. 3, which shows the side turn-under line of the body, is obtained by the application of the proportional triangle to the turn-under line E. Having assumed the amount of turn-under at E, Fig. 2, draw a line VI from Q on line R, Fig. 3. Lay out the turn-under line V and V, in Fig. 3, at the same heights as the turn-under lines in Fig. 1. Lay out the triangles D and E from the base line VI, Fig. 3, the apex of the triangle D located at a convenient distance below VI. When ever the sections cut the turn-under sweep at section V for example, square the intersection of the turn-under sweep to a large triangle at y. From y draw a perpendicular until it strikes small triangle at z. Square

point from z on to the section line V again, and this gives us point through which the turn-under sweep E passes. Continue this operation with all the sections until the desired points are obtained by which the completed sweep E is determined.

Now having the turn-under sweeps at A and E, let us next proceed to lay out the horizontal sections at 3, 4 and 5 through the body in Fig. 2. In order to establish these sections we will bring into use the proportional scale, Fig. 4. Let e, Fig. 4, represent the turn-under of the body at E, Fig. 2, and a the corresponding turn-under at A in Fig. 2. Lay out on e, Fig. 4, turn-unders at sections 3, 4 and 5, as taken from III-IV-V, Fig. 3. Likewise lay out the turn-unders on a, Fig. 4. Lay out straight lines between a and e at 3, 4 and 5, Fig. 4, and take the total turn-unders at D, C and B, Fig. 2, and lay them out on proportional scale in Fig. 4, at d, e and b. From this we can readily prick off our turn-unders at 3, 4 and 5, from d, e and b, and transfer the same on to D, C and B, Fig. 2. These points established, it remains only to connect them with proper side sweeps and we have completed the horizontal sections, 3, 4 and 5, from which, with lines 2 and 6, we can lay out the exact turn-under sweeps of the standing pillars at D, C and B, Fig. 1.

Fig. 5 is the proportional scale used in laying out the sections around the corner, Fig. 2. Fig. 6 is the proportional scale for laying out the sections through the shroud. Figs. 7 and 8, the one-half rear and one-half front views, respectively, are usually worked out after the turn-unders are determined.

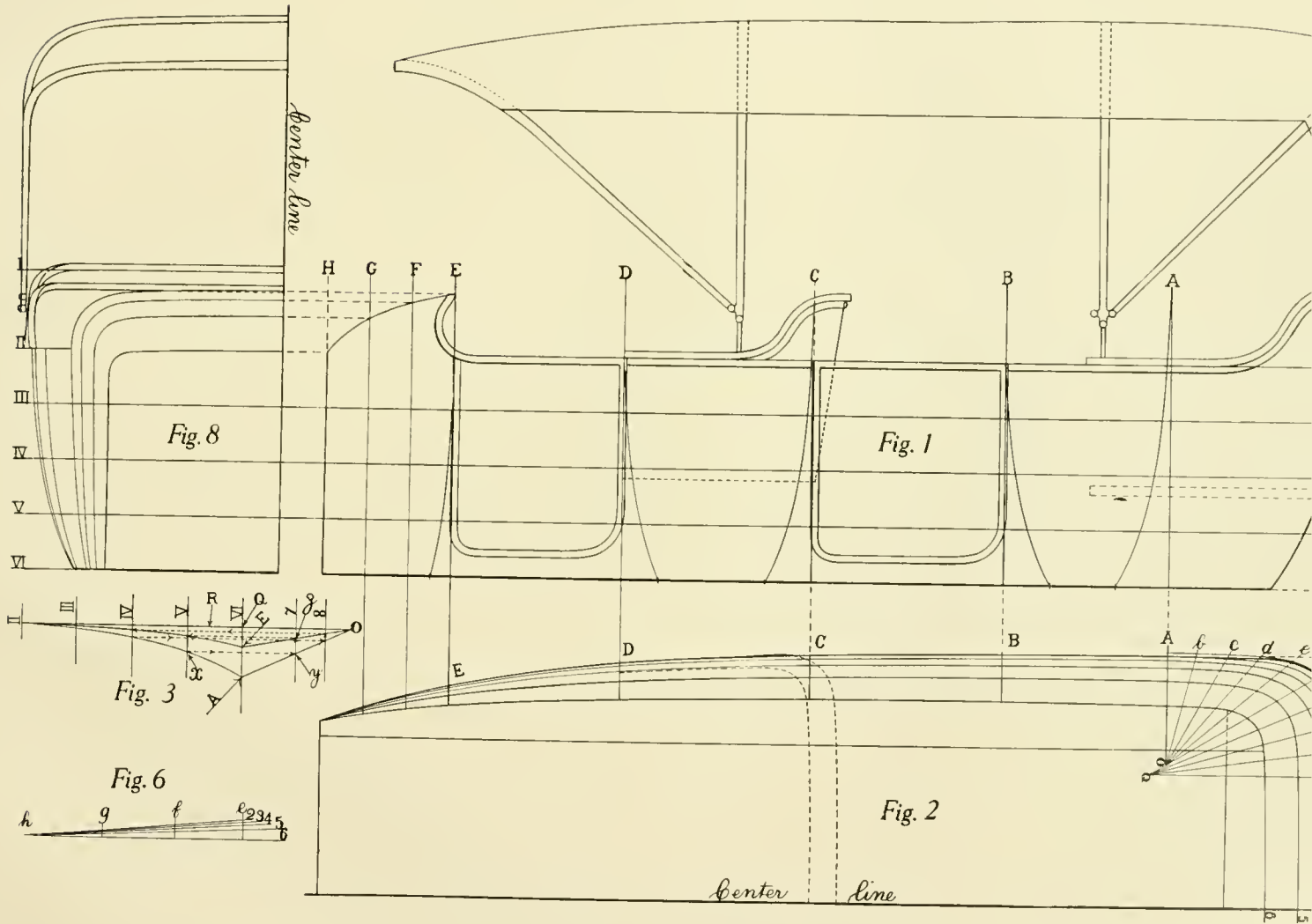

ILLUSTRATING THE LAYING OUT OF TWISTED OR WINDING SURFACES.

Working Out a Belt Line and Moulding for a Limousine Body

A graceful belt line around the corner and for a limousine body is sometimes difficult to produce a working line on the draft which will give satisfactory results is what we explain and illustrate in this problem. It is the belt line on the back of the body should be a sweep (usually the same as the roof), and at this, the belt line at the center of the back from 6 to 8 inches higher than the belt line at the side of the body, this, of course, depends on the width and design of the body, etc. The position of the belt line on the side of the back on Fig. 1. Between these are the horizontal section lines II, III, IV, V. Next lay out these intermediate sections on Fig. 2. To produce these sections in Fig. 2 we describe a system which has been explained in the text of that of the proportional scale, Fig. 3. To draw the sweep or curve, draw the line on the semi-circle from 1 to 3, number 3 being the point from which the line in Fig. 2 commences to round. This back to the horizontal section lines 2 and 3, Fig. 4. From the center line of the body to each section transfer same until they strike the sections in Fig. 2. Next project points 2 and 3 from Fig. 2 to the corresponding section lines. Connecting points

1, 2 and 3 in Fig. 1 will give us the line of the belt corresponding to the line intersecting points 1, 2 and 3, Fig. 4.

There now remains to be laid out the continuation of the belt line from point 3 to a in Fig. 1. This is worked out by the eye, and care should be taken to produce a graceful and true line. After the belt line on the profile in Fig. 1 is completed, project the same on to Fig. 2, and thence to Fig. 4. The line which we have established on Fig. 1 does not look as pleasing to the eye as would be desired, but, on the other hand, after the body is constructed and the line is viewed in perspective, it will be surprising to note what a graceful and well proportioned belt line this method will produce. It must be remembered that the corner of the limousine body is never viewed as it appears on the working drawing, but is always seen with a certain amount of perspective, and appears very much different than it does on the draft.

On metal paneled bodies the panels are joined at the belt line, and are usually covered here by a metal moulding, which is securely fastened to the body framing. This moulding is sometimes of soft metal, and sometimes of steel. If it is of soft metal it is not very difficult to form the moulding around the belt line on the job, but if it is a steel moulding that is used, it is desirable to bend or form the moulding flatwise first, and in order to do this a line should be laid out full length on a board or some indestructible article for the blacksmith, to be used in forming this moulding. To obtain the correctly developed line from the working draft, proceed as follows:

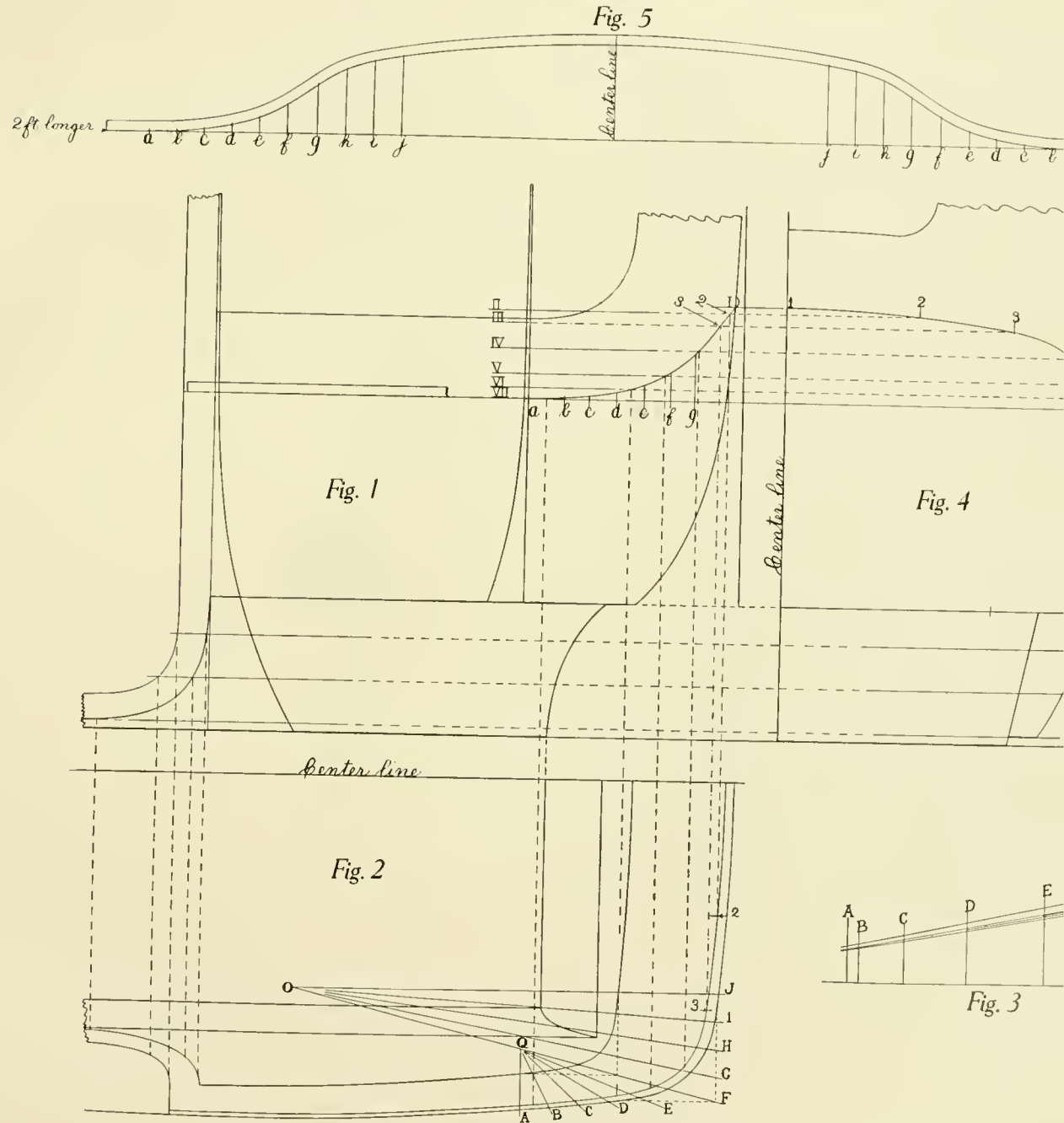

LAYING OUT A BELT LINE AND MOULDING FOR A LIMOUSINE BODY

LAYING OUT A BELT LINE AND MOULDING FOR A LIMOUSINE BODY—Continued

horizontal line, as shown in Fig. 5, and center line. Square from the horizontal line to the center line at points e, f, g, h, i, j, the distance between each center line is taken from corresponding center line in Fig. 2. From the horizontal line to the bottom of the belt moulding, prick off the height of the moulding at points b, c, d, e, f, g, etc., and corresponding lines in Fig. 5. Connecting these

points in Fig. 5 will give us the true shape of the belt moulding on the under side, when laid out flatwise. Gauge the top line of the moulding from this line.

In Fig. 5 it will be seen that the ends of the moulding are broken off short on account of lack of space, the moulding being marked two feet longer at each end. From this point on, the moulding is straight, and it is not necessary to lay this out as long as we take the correct length from Fig. 2.

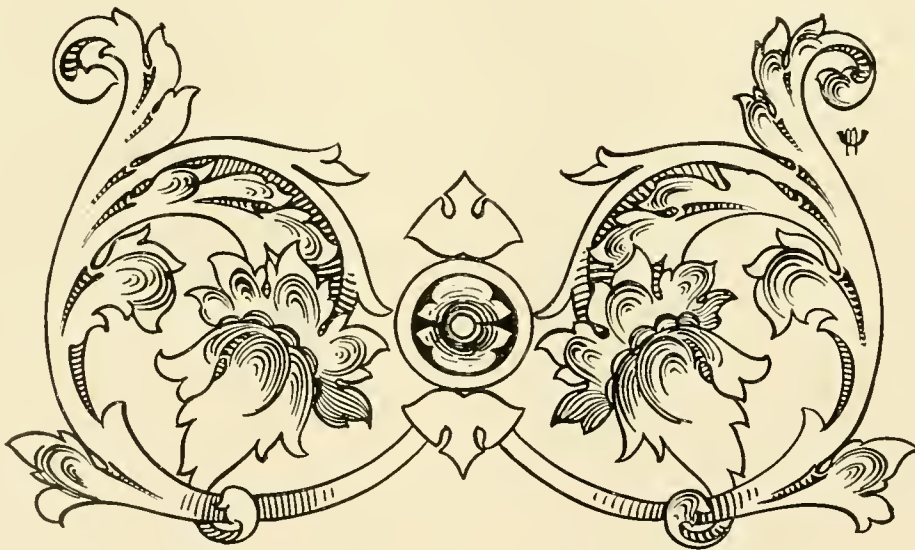

Pricking Off Corner Pillar on Twisted or Winding Landaulet Body with Example for Laying Out Jo

LAY OUT the profile of the body as in Fig. 1. Also draw the outside line of the body Y on the bottom view.

Then lay out parallel to line Y the bottom line of the body N-O, which for a distance is an imaginary line, but is useful in laying out the cheat line. Determine the amount of cheat wanted and lay out on the bottom view of the drawing as line Q. This is also an imaginary line, considering that the body side continues down to the base line H on the elevation. The adopted cheat line Q creates a twist in the side quarter of the body from vertical section line 8. This is invariably necessary on jobs of this kind for the purpose of producing graceful lines on the back view of the corner in Fig. 4. To determine the amount of cheat wanted, it is sometimes necessary to experiment until we work out what we think is the most pleasing line for the back view of the corner in Fig. 4. After the correct amount of cheat is found, we may adopt same as a standard for all jobs of this style so long as the body side sweeps and widths are uniform; therefore the line is something which cannot be developed, but must be assumed, and depends entirely upon the taste of the designer, and to execute properly requires considerable experience and skill.

To prick off the rear corner of this body, take into consideration the twist or wind in the side surface, and proceed as follows:

In Fig. 2 lay out the normal turn-under sweep of the body at section 8 as shown by the inside turn-under line O. Take the amount of turn-under from the extreme outside of the corner in Fig. 1 to the cheat line Q at the rear, and transfer on to line h-II, Fig. 2. From each turn-under as located on line

h-II, Fig. 2, lay out the proportion

apex for same being located on line

To produce the correct prop

extreme rear corner of the body.

The normal turn-under sweep

space off on same a number of lin

will. These lines also should pa

line in Fig. 1. At the point where

turn-under sweep in Fig. 2, drop

proportional triangle for the ne

intersected, and from these poi

striking the proportional triangle

sweep, and where same is intersect

on to corresponding lines a-A,

and g-G.

For example, take point on

through which line d-D passes in

line on to the line of the propor

below line h-II. Square this po

of the proportional triangle, and fr

projection until line d-D above h

produces a point through which t

sweep of the body at the rear c

proceed with all the other points,

sweep Q in Fig. 2. Where lines

Fig. 1, cut the line of the corner

points 2, 3, 4, 5, 6, 7 and 8, passi

of the body.

To produce the line of the c

and back views, proceed as follow

CORNER PILLAR ON TWISTED OR WINDING SURFACES OF A LANDAULET BODY WITH
EXAMPLE FOR LAYING OUT JOINT IRONS—Continued

nt of normal turn-under O in Fig. 2, and
e horizontal line h-H to a on line 8, in
tional scale. At any convenient distance
t from the horizontal base line h-H on
f turn-under with the cheat as taken from
. This will establish point A in Fig. 3,
nected by straight line with a on line 8.
f over-all turn-under on lines 2, 3, 4, 5,
om view of body, and wherever these dis-
nes a-A and h-II of the proportional scale
ical lines passing through the scale. Con-
mount of turn-unders at lines b-B, c-C,
g-G, Fig. 2, from vertical line X to the
sweep O, and transfer these turn-unders on
g. 3.

at points B, C, D, E, F and G on line 1,
m vertical line X to cheat turn-under line
ect corresponding points on lines 1 and 8
ght lines.

e 2, Fig. 3, take the amount of turn-under
ne b-B, and transfer from the outside of
corresponding line 2 in Fig. 1. Continue
3, 4, 5, 6 and 7, Fig. 3, being sure to take
of turn-under each time from the lines
o those in Fig. 1.

ed points on lines 2, 3, 4, 5, 6 and 7 in
h the bottom line of the corner pillar must
ansfer these points on to the rear view
, so as to determine the shape and width
pillar in the back view. In order to do
e center line of the bottom view, Fig. 1,
nes 2, 3, 4, 5, 6 and 7, and wherever the

corner pillar intersects same lines, transfer distances from the
center line in the back view, Fig. 4, to corresponding lines
B, C, D, E, F and G. The desired points obtained, connect
with graceful and pleasing sweep or curve, and we will have
worked out accurately the back view of the corner pillar, from
which the stock for same may be laid out with assurance that
it will work out correctly.

In laying out the joint irons for the top, the principal
object in view is to illustrate an accurate system for deter-
mining the center or the break of the joints. After having
designed the joint irons when in upright position, and having
located the props on the profile of the body, Fig. 1, lay out a
horizontal line from the center of the lower prop as shown
by dot and dash line on the illustration. Take the distance
from point II the center of the lower prop iron to the
center of the upper prop I as a radius, and describe an arc
striking the horizontal line at III. Determine the position of
the center line of the upper prop I after the top is lowered,
and with the compasses fixed at point I, or the center of the
upper prop, describe an arc V, the radius of which is greater
than half the distance from I to III. With the same radius,
describe arc IV from III intersecting the arc previously
described. Lay out the center line VI, which passes through
the horizontal line on which is located points II and III. This
intersection determines the center or break of the top joints.
From the center of the lowered prop I, to the center of the
joint or break on line II-III, describe an arc striking the
joint iron when in an upright position, and lay out the center
a little bit above a straight line passing through points I
and II. The center of the joint or break should always be
offset in this way in order to tighten or lock when in an
upright position.

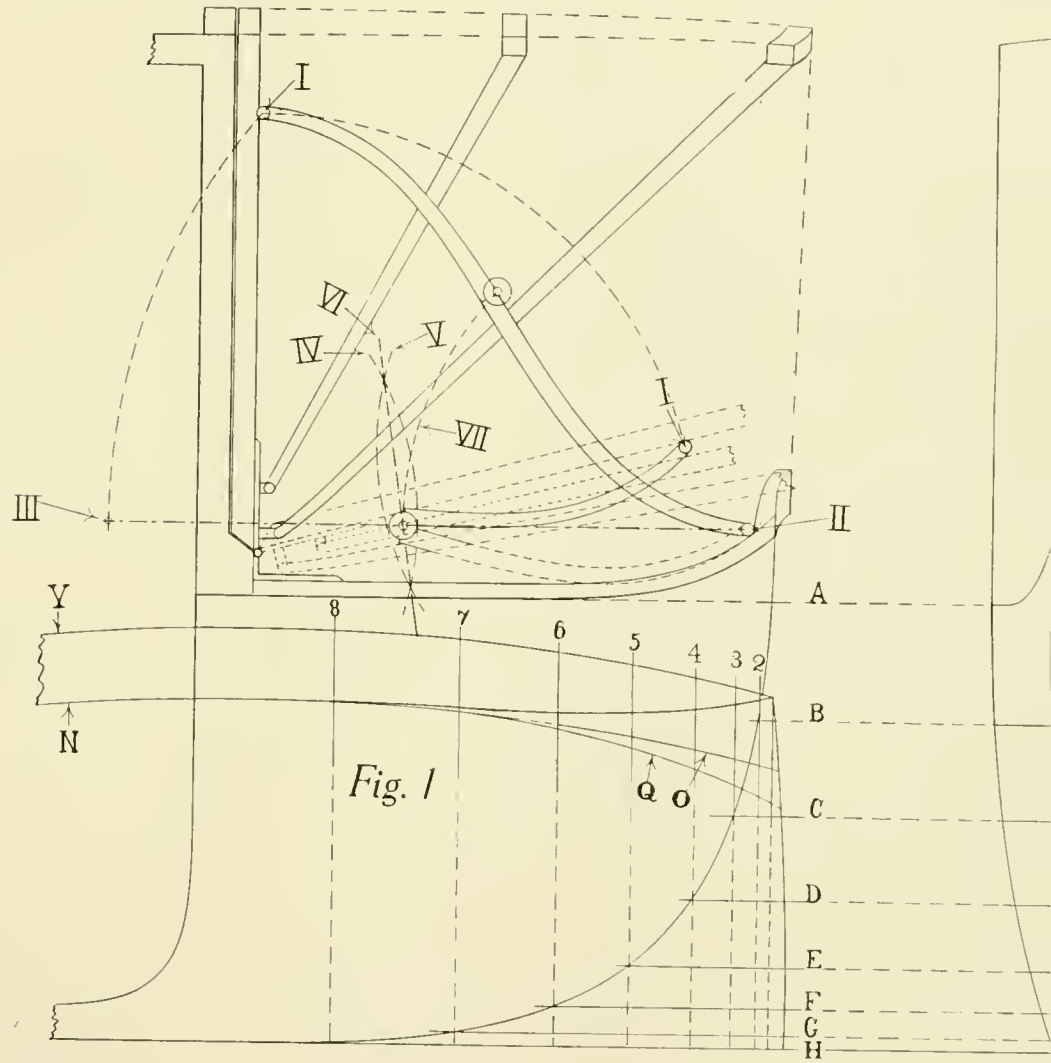
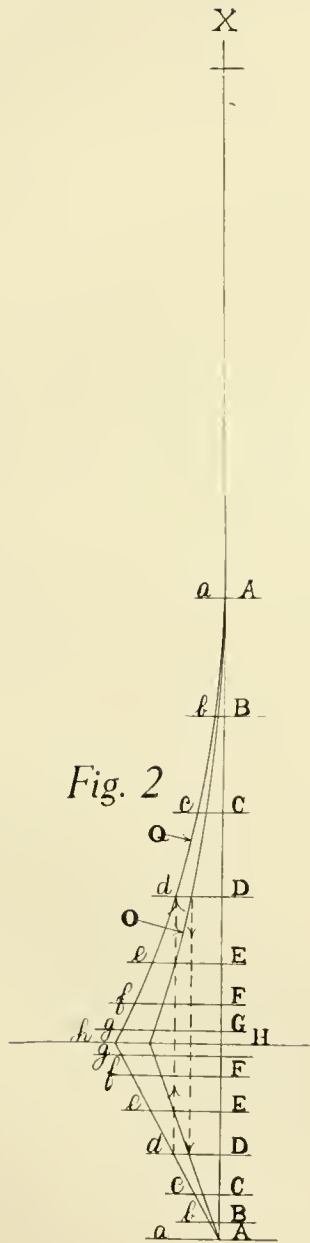

PRICKING OFF CORNER PILLAR ON TWISTED OR WINDING SURFACES OF A LANDAULET BODY WITH JOINT IRONS.

g Out of a Coupé Pillar and Construction of Forward Part of an Enclosed Body

our object is to teach the student how a coupé pillar in detail, which makes a very constructive problem. In addition we have run up briefly the ordinary construction for an enclosed body. This will be especially beginner, as it will give him a better insight into construction.

Decided upon the side view, turn-under and body, we will proceed to lay out the shut pillar. The bevel of the pillar where the door will be made to conform as much as possible to the face of the lock. From this point to the rear the bevel is the same.

Draw lines II, III, IV, V and VI, Fig. 1, and lines 2, 3, 4, 5 and 6, in Fig. 3. Determine the door will swing to open at sections 2, 3, 4 and 5. At 5 the bevel is the same as that on the door. The door will open without any trouble, but we cannot open the pillar below section 5, as the turn-under door opening farther away from the center necessitating a greater bevel in order to have the door opening. By trying the shut bevel at each section in the same manner it will be found that the greatest bevel is at the bottom of the door. Set the trammel on the rear outside edge of the coupé pillar in section 10, and describe an arc cutting the inside

and outside edges of the door, and connect intersections with a straight line, thus establishing the bevel on which the door will open at each section.

In order to obtain a perfect fitting door, the lock pillar and coupé pillar must be worked off to these different bevels, causing the inside face of the coupé pillar to be on a twist below the lock. Notice that the bevels of the coupé pillar are worked each time from the rear outside edge of the coupé pillar. This gives us a straight line for the front of the door and rear of coupé pillar in Fig. 1.

Referring to Fig. 3, A, B, C and D are points on the outside of the coupé pillar at sections 2, 3, 4 and 6. Points a, b, c, d are points on the inside of the coupé pillar at corresponding sections.

From the door line to the inside of the coupé pillar same should be rabbeted out $\frac{1}{4}$ inch to allow for the trimming. This is shown on Fig. 1 at sections II, III and IV, also on Fig. 4 at section VI.

In connection with Figs. 2 and 4 we have shown the header, which should be securely framed into the coupé pillar by means of a mortise and tenon joint, as illustrated in section 10. *p* in Figs. 1 and 4 represents the head rail or roof rail, into which the coupé pillar should be framed by means of a mortise and tenon joint, as illustrated more clearly in Fig. 2 and section 10.

Between the two coupé pillars there are two drop windows which require a center post, Figs. 5 and 6. This center post

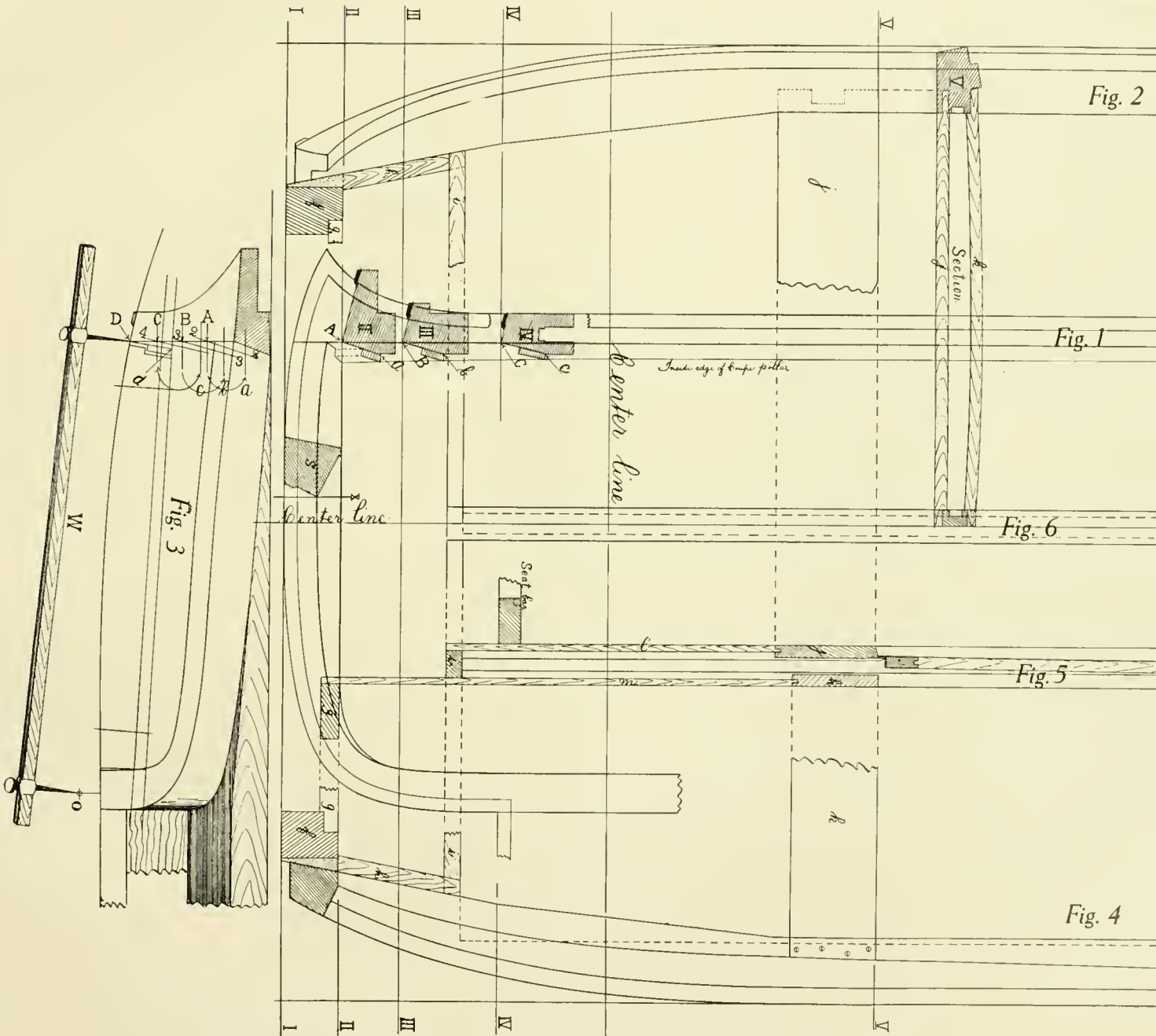

THE LAYING OUT OF A COUPE PILLAR AND CONSTRUCTION OF FORWARD PART OF AN ENCLOSURE

ING OUT OF A COUPÉ PILLAR AND CONSTRUCTION OF FORWARD PART OF AN
ENCLOSED BODY—Continued

leader by means of a mortise and stump
lapped into the cross-bar i, Fig. 5.

represents the neck-bar, which is mortised
as shown in Fig. 2. Sometimes it is
to this into the coupé pillar.

5, represents the garnish board on the
and on to which is secured the trimming
moulding. This should be in two pieces
to give clearance enough for, and facilitat-
the window frames. The garnish board
l into the coupé pillar, and screwed, but

and the garnish board k, Fig. 5, are
ve the lining boards l and m, which are
a to the cross-bars i and g, Fig. 5.

resents a post framed into the sill f and
s post forms a bearing for the inside of
h is secured to the same by means of glue

In Fig. 5 we illustrate a light construction for the division
window posts, that is, of fastening $\frac{1}{2}$ -inch x $\frac{1}{2}$ -inch angle
brass to the bottom edge of the glass frame, and permitting
one web of this angle to straddle the fence iron instead of
having the complete frame to jump the fence, as is customary
in most cases. By the use of this construction we lighten the
division post in Fig. 5 at least $\frac{5}{8}$ inch, or the thickness of
the frame.

p, Fig. 4, shows the roof rail rabbeted out to receive the
roof board, which is usually of three-ply veneered stock, and
should be glued securely and nailed frequently. Over this is
glued the roof cloth, which should extend far enough outside
of the roof to cover the joint between the roof board and
the roof rail.

Section V shows section of the coupé pillar neck-bar and
garnish rails at the fence line. It will be noted that the
garnish board k in section V is in two sections, and is swept
so as to give clearance for window pull when the window is
lowered or raised.

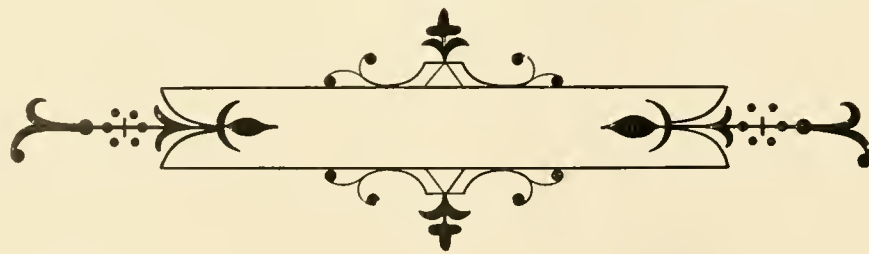

The Framing Up of a Door and Pricking Off of a

THIS ARTICLE supplements the laying out of a coupé pillar and construction of forward part of an enclosed body. There are a great many different methods for framing up doors. Every bodymaker has his own ideas in regard to this subject. Let this article be intended more for the apprentice than for the experienced bodymaker.

a and b, Fig. 1, represent the door pillars, a being the hinge pillar, and b the lock pillar. The thickness of the hinge pillar is $2\frac{1}{8}$ inches, while that of the lock pillar is about $2\frac{1}{4}$ inches on the outside. These thicknesses are sometimes made more or less, according to the style and construction of the body. e and f are the top rails; g is the lock board; c and h are the fence and belt rails, respectively; j is the lining board; and i is the bottom board. In grooving out the door pillars for the glass frame runs, it is necessary that these be grooved out square. d is the bottom rail of the door, and is half-lapped into the lock and hinge pillars, the joint for the hinge pillar being shown at a and d.

Fig. 7 shows two methods for framing the outside top rail e into the door pillars. Either method will be found practical. The joint used for framing the top rail e into the hinge pillar a is that of a bastard tenon. In framing the top rail e into the lock pillar b we use a stump tenon. The inside rail f is rabbeted into both pillars. Great care should be taken in framing the outside top rail e into the pillars, being sure to get a tight-fitting joint and as much stock outside of the tenon as practical.

Fig. 3 shows a section of the door at the fence line, and

the method used for framing a into the door pillars. The fence pillars a and b. The lock board a and b. The belt rail h is also pillars. The bottom board i is ha a and b. In this construction it bottom side d into the door pilla all the strength required.

Fig. 6, the section taken at shows the glass frame run and c laying out glass frame runs, ca plenty of clearance for the glas out sticking and at the same glass frames are $\frac{5}{8}$ inch thick, wide at the fence and top and for clearance, and also paint. It width of the door pillars at the the outside of the pillar to the wi 11 16 inch for the window seat plate, $\frac{1}{8}$ inch clearance, another 1 run, $\frac{1}{8}$ inch more clearance, and; the width of the door pillars a in Fig. 6.

Determine the length of the project above the lower edge of about $\frac{3}{8}$ or $\frac{7}{16}$ inch, and lay frame run below the fence line glass frame or window to drop

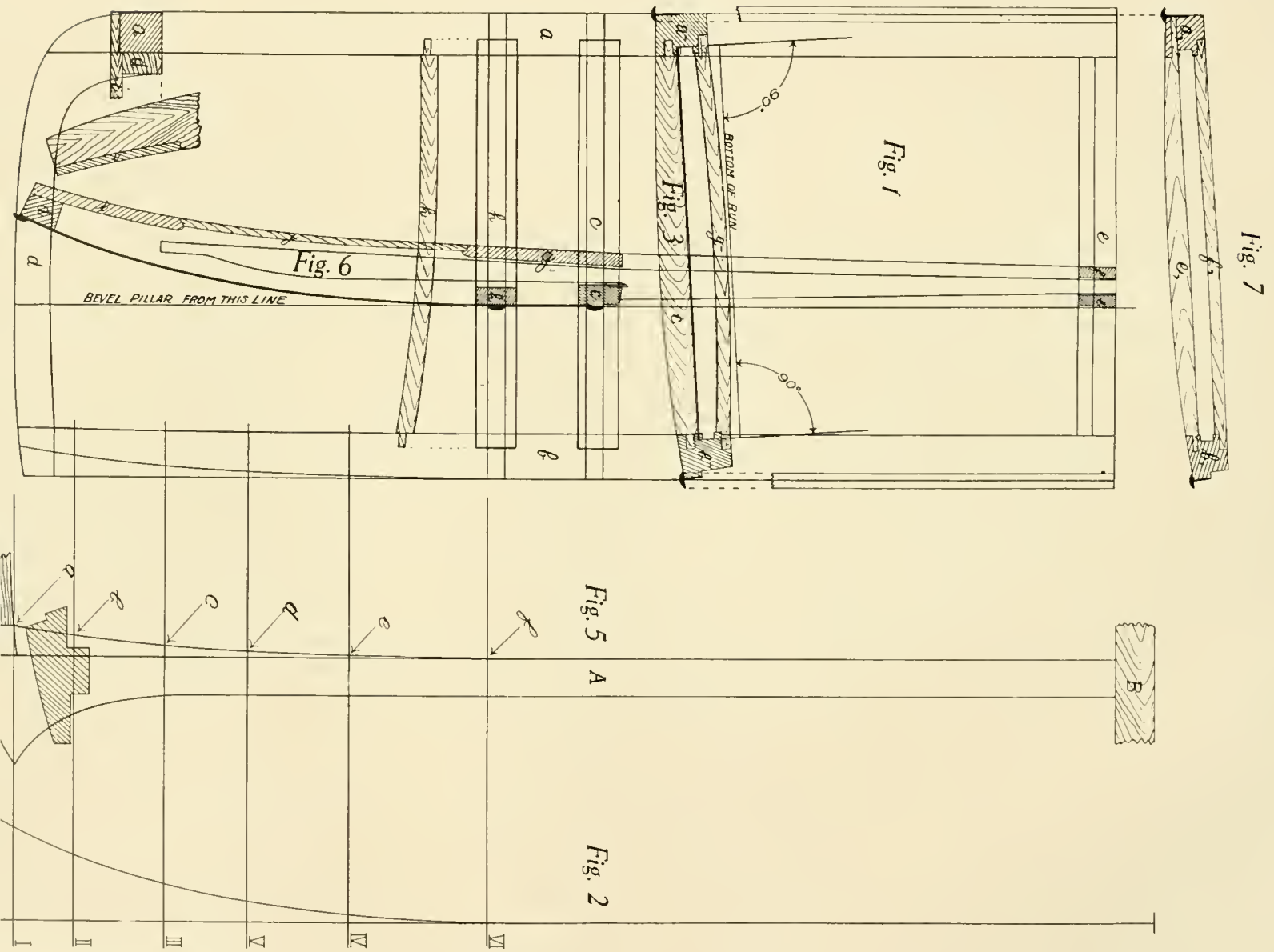

THE FRAMING UP OF A DOOR AND PRICKING OFF OF A COUPÉ PILLAR.

THE FRAMING UP OF A DOOR AND PRICKING OFF OF A COUPÉ PILLAR

make this calculation so that about $\frac{1}{4}$ or $\frac{3}{8}$ inch of the top frame of the window will show above the fence plate, although in some cases it is impossible on account of the conditions of the chassis, sometimes necessitating cutting the corner of the door, which prevents the window from dropping clear down. At the lower end of the glass frame run in Fig. 6 note that the run is $\frac{11}{16}$ inch wide, and parallel for a short distance. This causes the window to fit closely at the bottom, and prevents chattering at this point. The glass frames should never come in contact with the window runs, there usually being screwed channel rubbers on the ends of the frame which work up and down in the runways. There should be plenty of clearance between the door bars, lock board, lining boards and the glass frames. As there is usually attached a strap to the bottom of the glass frame for raising the window, it is always advisable to sweep the lock board *g* in Fig. 3, which gives clearance for this strap and fixture. Set the lock board and lining boards so that they may be easily removed in case of any interference on the inside of the door. The lock board should not be glued to the pillars, but just screwed, and the joints should be well painted. Always give the runways a coat of linseed oil or primer as soon as possible.

Referring to the framing up of the top and fence rails, we advise that the rails be recessed or set under $\frac{1}{16}$ inch, as shown in Fig. 6, thus breaking the joint.

These are a few general instructions and hints which may apply to the framing up and construction of any high door, but should not be regarded as fixed rules.

With reference to the pricking is shown in Fig. 5 at *A*. Fig. pillar, and *B* is the top rail. *C* represents a section of the coupé bevel throughout.

In getting out a coupé pillar v to bottom, that is, beveling the pillar from the outside of the pillar before causes the coupé pillar to be heavy a simple method for getting the s and has been employed in carriage of the body was not very great where the bodies are a great deal turn-under, it is not found as s explained in the problem for lay construction of forward part of a as it produces a curved line pass d, *e* and *f*, Fig. 5, which causes the bottom than it is at the top.

In pricking this pillar off, lay I, II, III, IV, V and VI through amount of turn-under at each section out on Fig. 4, passing through the pillar. Wherever these sections a, *b*, *c*, *d* and *e*, Fig. 4, project corresponding sections at *a*, *b*, *c*, connecting these points gives us the line pillar and door.

The Construction of Glass Frames

al may be said in regard to the construction of glass frames, but in this article we will treat only one construction, which, like any part of a machine, is left upon the judgment of the mechanic.

Figure 1 shows an assembled glass frame, a being the bottom, b the back, c the top, and d the front. The frame is held together without injury to the frame.

To accomplish this it is necessary to leave two of the joints open. In this case we leave the lower joint in the left hand corner and the upper joint in the right hand corner. The frame will be in two pieces. If all the joints were tight, and anything happened to the glass that would be almost impossible to reset a new pane. As it is constructed here, this can be done without injuring the frame in any way. The top and bottom of the frame is rounded off as shown in Figure 1. The joints should be mitered at the inner corners as shown in Figure 1, as illustrated in Fig. 1.

Figure 1, show the lower part of the front piece d, and the shape of the tenon which is let into the bottom piece a1. The same kind of a joint is used at the corners except the round corner, and this is a bare-face mortise and tenon. b1 and b2, show the lower end of piece b. It also shows the joints. a1 and a2 show a part of the bottom piece mortised to take the tenon on the back piece. The shoulders run horizontally on the lower part of the frame to prevent raising and lowering of the window

causes considerable strain on these lower joints, and in constructing them this way they are much stronger and there is less liability of the joints opening up. If the shoulders were vertical on the lower frame, all the strain would be on the tenons, and the joints would be more liable to open. Notice that the tenon on d1 in Fig. 1 is cut on an angle, which is also true of the tenons on the top piece c.

Another way for constructing the joint at the round corner or joining the two pieces a and b is shown in Fig. 2. In this method we mitre the two pieces together and unite them with a false tenon. This joint is frequently used, but is not as reliable as that shown in Fig. 1 because it shows a longer joint and there is more liability of the joint opening.

Fig. 4 represents a section of a glass frame which is rabbeted out to receive the glass. The rabbet is made deep enough to allow for a moulding which is fastened on the inside of the frame to hold the glass in place. Using this construction it is possible to glue all joints in the frame, as the window glass is fastened and held in place by means of the moulding b.

Referring to Fig. 3, b shows a section of the glass frame grooved out to receive the glass f. In using this construction there should be placed between the glass and the frame a thin strip of rubber, as shown by e. This holds the glass tight in place and prevents rattling, which is sometimes the case when the glass is not of uniform thickness and the glass frames are grooved out uniformly. This rubber is shellaced to the glass. Sometimes nothing but putty is used for setting the glass, but, if rubber cannot be procured, we believe felt will be found to give satisfaction.

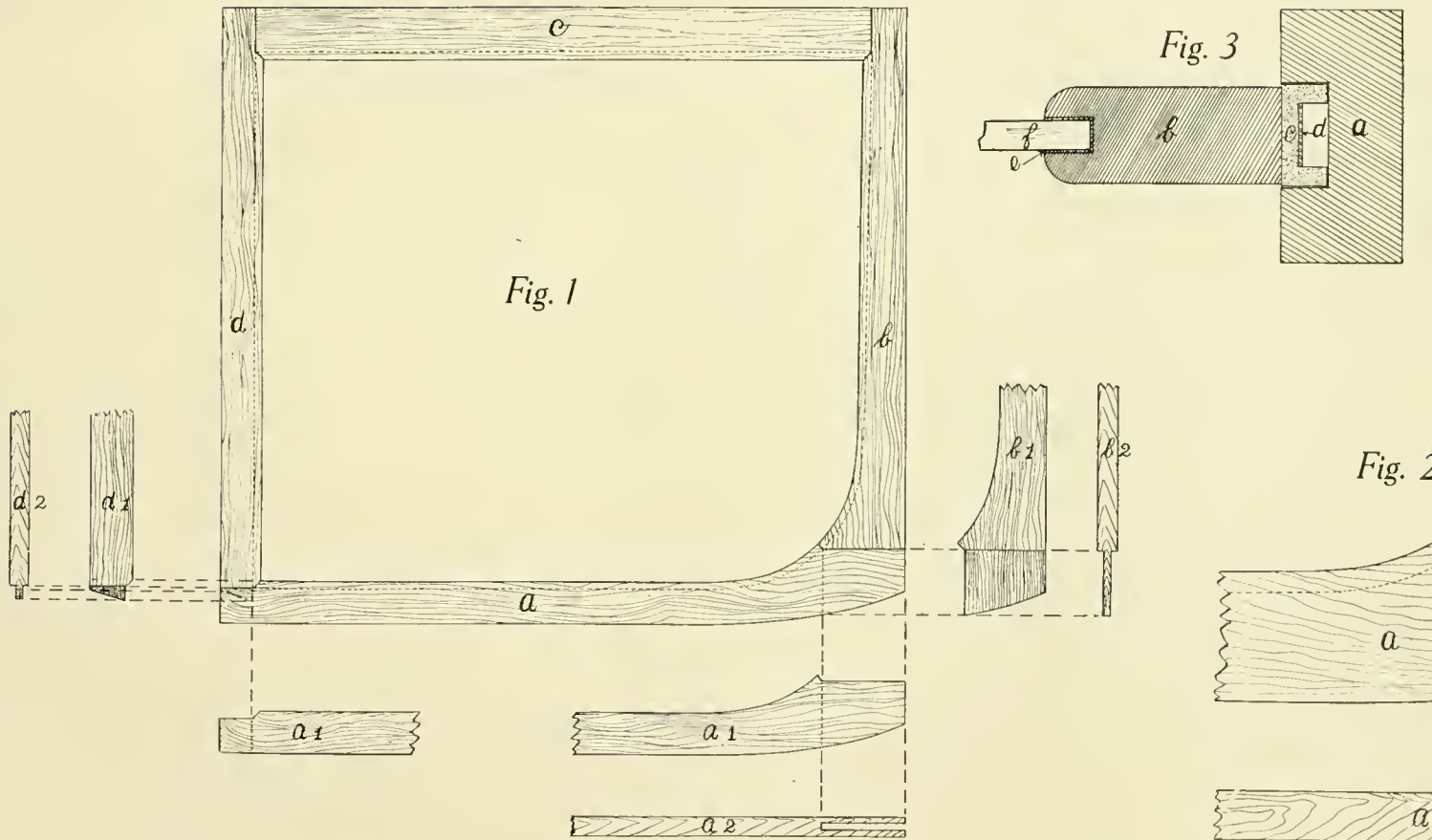

THE CONSTRUCTION OF GLASS FRAMES.

THE CONSTRUCTION OF GLASS FRAMES—Continued

fly of the method for setting the glass frame
. 3. represents the door pillar grooved out
On the end of the glass frame is serewed
The plate d is usually set inside the channel
screws are put in from the inside and through
channel rubber c should fit closely into the
in the pillar a, Fig. 3, and the glass

frame itself should not come in contact with the glass frame
run. Glass frames are usually made of mahogany, and the
finish is important; therefore pains should always be taken to
obtain perfect fitting joints, and the best of judgment should
be used in the construction of the joints, for which there is no
law laid down, but the foregoing are simply some practical
hints on construction which has proven very satisfactory.

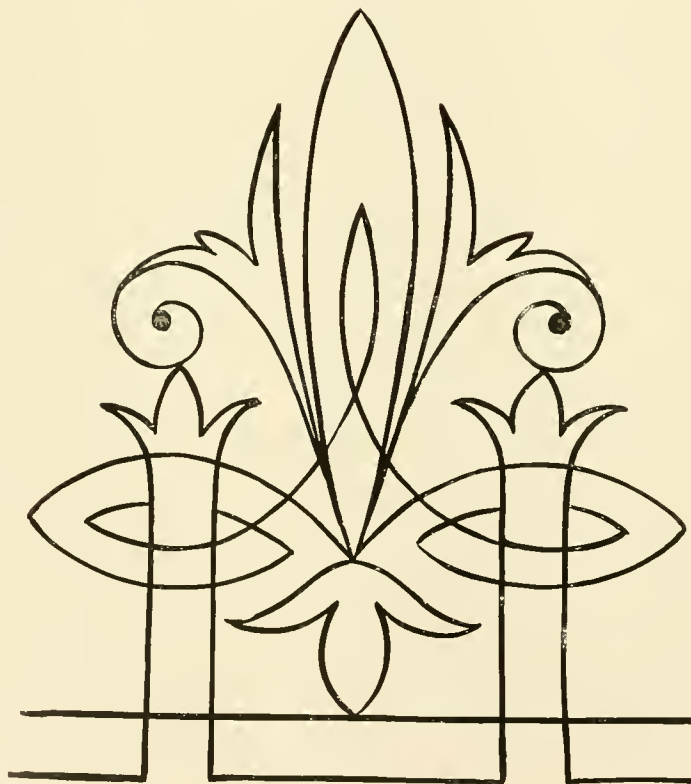

The Laying Out of a Wheel-house and Rear Mud

IN A BODY which is especially wide across the rear seat it is often necessary to make a wheel-house, or depression in the side of the body, so as to give sufficient clearance for the rear wheel. In this event the rear mud guard usually fits into or close to this wheel-house, and conforms somewhat to its shape. We will first take up the method for laying out the wheel-house in a body, such as illustrated.

Lay out the profile of the wheel-house and mud guard on the side view of the body, Fig. 1. On the rear view, Fig. 4, determine the amount of clearance necessary between the body and the wheel, and lay out inside line of wheel-house t-q-x. From Figs. 1 and 4 we will lay out the wheel-house on the bottom view in Fig. 2.

On Fig. 1 lay out on the profile of the wheel-house, points 2, 3, 4, 5, 6 and 7, arbitrarily, and by means of the proportional scale in Fig. 5, lay out sections in Fig. 2 taken at heights of points 2, 3, 4, 5, 6 and 7 in Fig. 1. Squaring these points from Fig. 1 on to sections in Fig. 2 will establish points through which the outside of the wheel-house line r must pass. The inside line of the wheel-house t should be taken from the section of the wheel-house at t on Fig. 4, and transferred on to Fig. 2, where it will show as a horizontal line.

Wherever the outer line of the wheel-house intersects the inner line at the front and rear, numbers 1 and 8, Fig. 2, square down points intersecting the profile of the guard, establishing points 1 and 8 in Fig. 1. Lay out horizontal section lines 10, 11 and 12 on Fig. 1. By means of the proportional scale, Fig. 5A, lay out these sections through the inside line

of the wheel-house t on Fig. 2, and inside line of the wheel-house t drop they strike the corresponding sections these points 10, 11 and 12, with 1 the bottom line of the wheel-house where the surface of the wheel-house of the body.

It will be seen on Fig. 2 that $\frac{3}{4}$ inch wide around the top of the be set into the wheel-house level across a bearing for the mud guard. The wheel-house and is secured at this level.

In Fig. 6 we have the turn-under the turn-under sweep at corresponding Fig. 2. Fig. 3 is the turn-under a round corner on the side at A, Fig.

After this much is understood it is a simple matter it is to lay out the necessary to lay out the profile of Fig. 2 the inside line s of the ledge represent the inside line of the guard 1 and 8. Determine the width of t lay out inside line of same in Fig. 8 of the body at 9. Connecting 8 and of the guard, Fig. 8, as far as 1. closely the side of the body until it reaches frame. From this point until it joins usually cut away for the spring or b

PRACTICAL PROBLEMS FOR VEHICLE DRAFTSMEN AND MECHANICS.

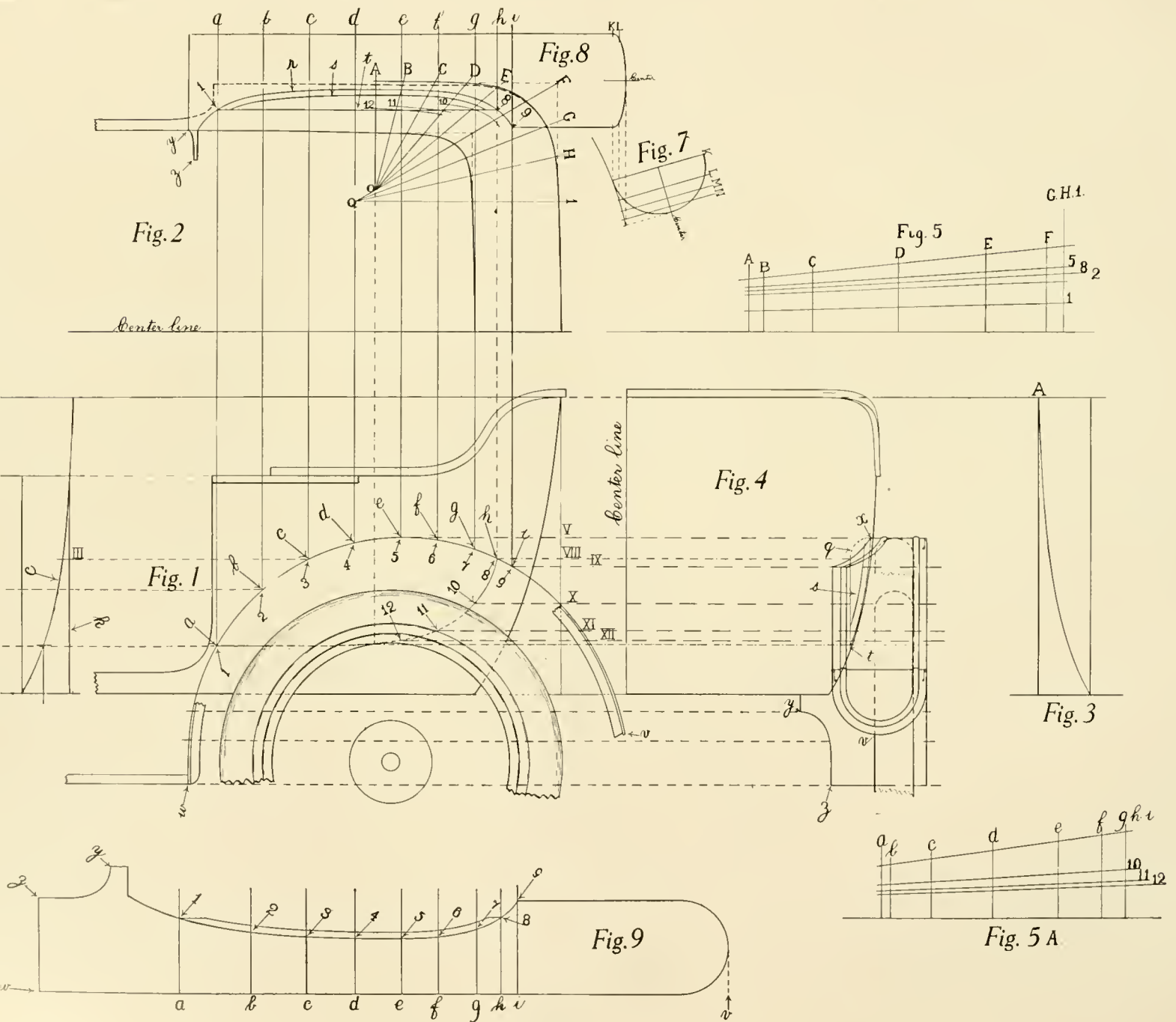

LAYING OUT OF WHEEL-HOUSE AND REAR MUD GUARD.

THE LAYING OUT OF A WHEEL-HOUSE AND REAR MUD GUARD—Co

Fig. 4. Lines a, b, c, d, e, f, g and h, Fig. 8, are projections from points 1, 2, 3, 4, 5, 6, 7, 8 and 9 in Fig. 1, and will be used in developing the pattern of the guard in Fig. 9.

Fig. 7 shows a section of the rear end of the guard as taken from Figs. 1 and 4 and brought up close to Fig. 8, with the end squared from the profile in Fig. 7, for the purpose of working out the points K, L, etc., on the plan view of the end of the guard in Fig. 8. Let lines K, L, M and N be drawn through the end of the guard until they strike the profile in Fig. 7. Draw vertical lines from each point through the end of the guard on Fig. 8. From the center line on Fig. 7 take the widths of the guard at K, L, M and N, and transfer on to corresponding lines from the center line in Fig. 8. This gives us a true view of the rear end of the guard in Fig. 8, although the same is not necessary for laying out the pattern in Fig. 9.

The sole object for laying out the guard in Fig. 8 is for pricking off the widths at various points to be used in developing the pattern, Fig. 9. To obtain the pattern, Fig. 9,

it is first necessary to lay out the full width of the guard around the curve of the profile with the true developed length on the outside edge of the guard. Transfer distance between points w, x, y, z, Fig. 1 to the pattern, Fig. 9, with the true length of the guard w to get the true length of the pattern. Through these points in Fig. 9 draw vertical lines outside of guard. Transfer widths of the guard at points b, c, d, e, f, g and h, Fig. 2, to corresponding lines of guard in Fig. 9, establishing points p, q, r, s, t, u, v, w, x, y, z, Fig. 9. Connecting these points will give the true shape of the guard where it fits into the wheel.

Lay out the round end at the rear of the guard with the same round or radius as in Fig. 7. Lay out the front of the guard from Fig. 4 on to the pattern. Lay out the necessary flanges all around the guard. Lay out the pattern ever may be desired, and the pattern is ready for cutting out the stock.

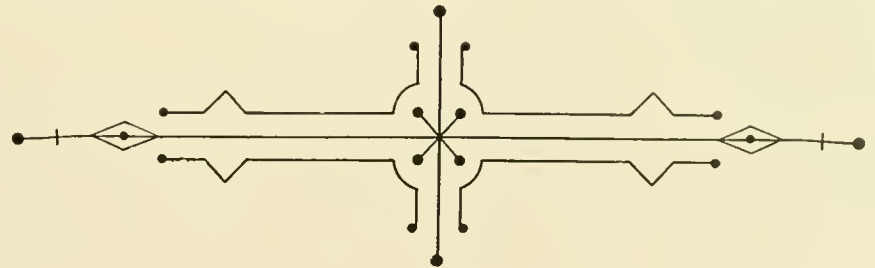

Laying Out Pattern of Panel for a Metal Seat by the System of Triangulation

TRIANGULATION is a system for measuring up and laying out surfaces for the purpose of obtaining patterns for sheet metal work, and has long been used for many years by sheet metal workers and cornice makers. It is commonly used in the automobile and carriage trade in making patterns for seats with straight flares, but cannot be used on seats with convex or concave both ways, or, in other words, seats that are to be hammered. For a convex or "King" seat this system would be of no use, but for a seat with a straight flare, as illustrated herein, or for mud guards, fenders, fly panels, etc., it is invaluable, inasmuch as it saves the time and expense of setting up temporary forms for obtaining the desired patterns.

In the illustration, Fig. 1 is the elevation of a seat, and Fig. 2 is one-half the bottom view. From these two views that we obtain the pattern of the

seat. In laying out the pattern of the seat it is necessary to lay out the arm rail in Fig. 2 as it drops down to the seat. Space off on the top line around the seat 3, 5, 7, 9, 11 and 13, Fig. 2, commencing at the back, where the seat starts to round at the back, and continuing around as shown. Space off as many parts equally as shown in Fig. 2, connecting these points on top and bottom of the seat with straight lines, project same points

and lines on to corresponding positions in Fig. 1. Wherever the arm rail line on the profile intersects the oblique lines connecting top and bottom points of seat, Fig. 1, project these points on to the corresponding lines in Fig. 2.

For example, take point VII on line 7-8, Fig. 1, and project horizontally until same strikes line 7-8 at VII in Fig. 2, thus establishing a point through which the arm rail in the bottom view must pass.

Lay out the triangles from these points on the arm rail and points on the seat bottom on Figs. 1 and 2 as shown.

In starting the pattern, Fig. 5, lay out the center line OQ, which is equal to the full height on the flare of the seat at the back, Fig. 1. With the dividers take the distance from Q to 1 on the top line of the seat, Fig. 2, and transfer on to the pattern, using this distance as a radius, and swing it out both sides of the center line from Q.

In order to find the intersection of point 1 on these arcs, proceed as follows:

Use the distance from O to 1 in Fig. 2 as the base of a triangle, and lay same off on any convenient space on the drawing, as Fig. 4, O to C. Taking the height of the seat perpendicularly from the bottom to point 1 at the top as the altitude or perpendicular, lay out on the triangle chart in Fig. 4, C to 1. Connecting O with 1 in Fig. 4 will give us the hypotenuse of the triangle or the true length of line

PRACTICAL PROBLEMS FOR VEHICLE DRAFTSMEN AND MECHANICS.

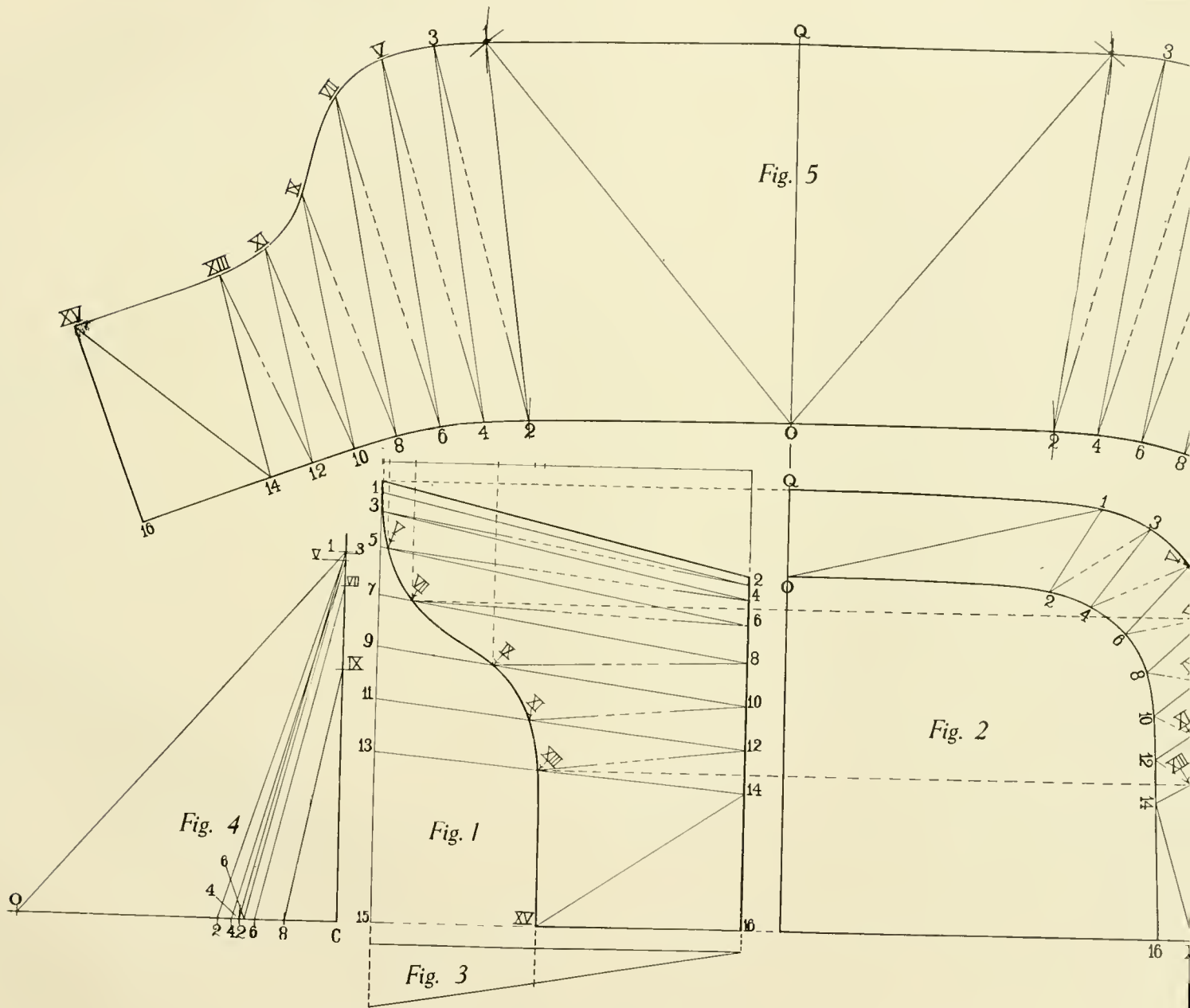

LAYING OUT PATTERN OF PANEL FOR A METAL SEAT BY THE SYSTEM OF TRIANGULAR

PATTERN OF PANEL FOR A METAL SEAT BY THE SYSTEM OF TRIANGULATION—Continued

distance should be laid out from O on Fig. 5. The arcs are drawn from Q at 1.

From point 2 on pattern, take distance from O to 2, and lay it off as a radius from O, Fig. 5, both sides. Then take the distance 1 to 2, Fig. 2, as a base of a triangle and lay it off on Fig. 4 from C. Connect 1 and 2. This line is the true length of the line sought, and lay it off from point 1, Fig. 5, until it intersects the arc at 2, and so on until the arm rail commences at 3. After 3 on Fig. 2 we cannot take the spaces between lines direct, as same is dropping until it runs parallel to line at XIII.

To space the top line of the arm rail correctly on Fig. 5 it is necessary to lay off another line to obtain the true length of lines between 3 and 4. This is done as follows:

From line 3 to V, Fig. 5, take the space from 3 to 4, and lay it off from C on Fig. 6 as the base of a triangle. The amount that the arm rail drops, from 3 to 4, lay it off from C on vertical line as the alti-

tude, Fig. 6. Connecting 3 and V will give us the hypotenuse of the triangle c3V, Fig. 6, which is the true length of line 3 to V, Fig. 2, and should be laid off from 3 on Fig. 5. The same operation is necessary for every space on the arm rail between V and XIII, laying out each triangle to obtain the true length of each line.

As the points on the arm rail after 3 are getting lower it is necessary to change the altitude of each triangle on Fig. 4. Take the distance from 8 to IX, Fig. 2, for example.

Using line 8 to IX as a base, lay this distance out on Fig. 4 from C to 8. Take the perpendicular height of IX on Fig. 1 from the seat bottom and lay it out as the altitude, Fig. 4. Connecting 8 and IX, Fig. 4, will give us the hypotenuse of the triangle or the true length of line 8 to IX, Fig. 2, which should be laid out from 8 on Fig. 5 until it intersects the arc drawn from VII at IX. Continuing these operations with all the points as shown will give us the outline of the pattern, Fig. 5. Around this pattern whatever flanges are necessary for turning under the seat frame and railing, etc., may be added.

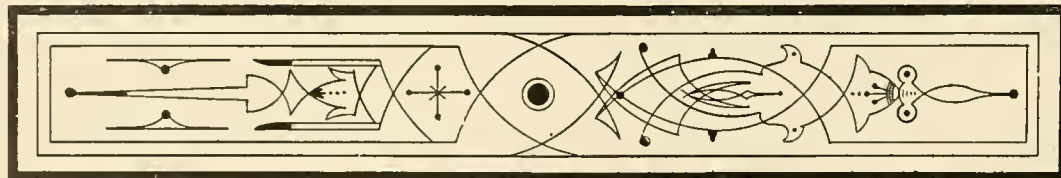

Laying Out of Pattern for a Shroud Panel

THE SAME system of triangulation is applied in this problem for obtaining the pattern of a shroud as was used for working out pattern of the metal seat panel.

The elevation and front view of the shroud, Figs. 1 and 2, are first laid out. Then on Fig. 2, the front view of the shroud, space off points on inner and outer lines as indicated by numbers. The location of these points is not fixed by any rule, but good judgment should be used in placing them where necessary only, the corners being the parts where the spaces should be laid out most frequently in order to insure the most accurate results. The flat or nearly flat surfaces do not require as many triangles. Connecting the points on the inside and outside lines of the shroud in Fig. 2 will establish the triangles with which we will lay off the full pattern of the shroud in Fig. 5.

Lay out the full length of line O-Q on the center of the pattern, Fig. 5, as taken from Fig. 1. In spacing off the points on the back line of the pattern in Fig. 5, do not take the distances direct from the outer line on Fig. 2, as these spaces do not represent the exact length of the lines, as well be seen by looking at Fig. 1. The rear line of the shroud slants back toward the bottom. Therefore lay off triangles for each space separate, as in Fig. 6.

For example: In spacing off point 1 in pattern, Fig. 5, take the distance from 1 to Q in Fig 2, and lay it off as the base of a triangle on line a-a, Fig. 6, from Q. Take the distance that the shroud slants back, Q to 1 in Fig. 4, and lay

it out in Fig. 6 from line a-a to the true length of the line Q to 1 in Fig. 4, and swing off both sides of Q in Fig. 6.

In order to find point 1 in Fig. 5, take the distance of line O to 1 in Fig. 2, as follows:

Square upon line a-b in Fig. 4. Take the distance from O to 1 in Fig. 2, and lay it off on line a-b at the front line of the shroud, O and 1, and we will have the true length of the line a-O-1 in Fig. 4, or the true length of the line O to 1 in Fig. 2. Lay this distance off from O in Fig. 5, and arcs are drawn from Q at 1.

To describe the arc from O, point 1, be located, take distance directly from O to 1 in Fig. 2, same as the radius for describing the arc from O, line of the shroud is perpendicular to the line a-b in Fig. 4. numbered points can be taken directly from Fig. 2. For finding point 2 on the pattern, take the distance 1 to 2 in Fig. 2 as the base of a triangle, and draw a vertical line from a in Fig. 4. Take the distance from 1 to 2 on to the line a-b in Fig. 4. From point a, draw an arc of the triangle a-1-2, or the true length of the line 1 to 2 in Fig. 2. Lay out this distance from a, and where it intersects are drawn from O at the same distance. In the matter of getting the true length of the line O to 1 in Fig. 2, the true length of the line O to 1 in Fig. 2. Lay out this distance from O, and where it intersects are drawn from O at the same distance. In the matter of getting the true length of the line O to 1 in Fig. 2, the true length of the line O to 1 in Fig. 2. Lay out this distance from O, and where it intersects are drawn from O at the same distance. In the matter of getting the true length of the line O to 1 in Fig. 2, the true length of the line O to 1 in Fig. 2. Lay out this distance from O, and where it intersects are drawn from O at the same distance.

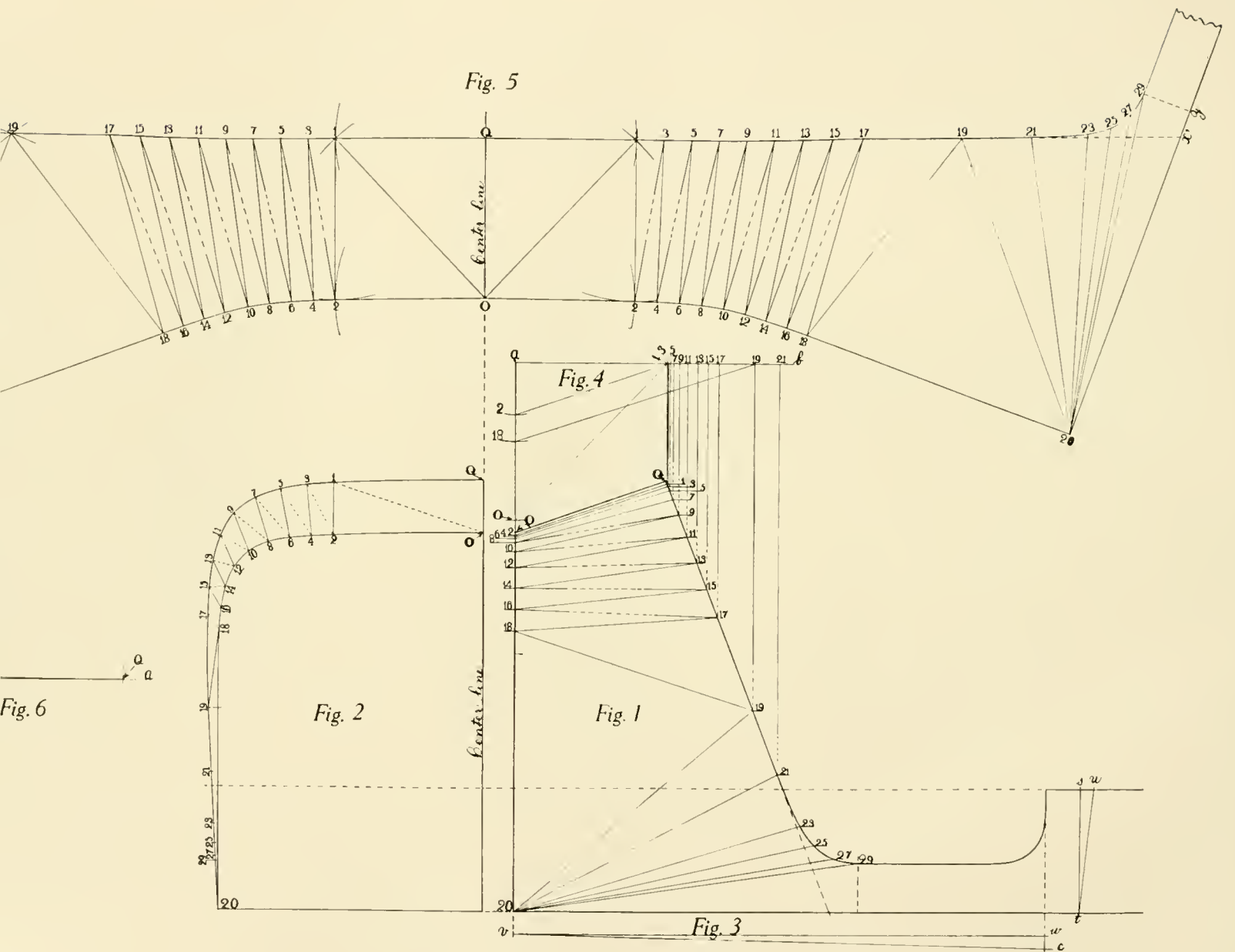

LAYING OUT OF PATTERN FOR A SHROUD PANEL.

LAYING OUT OF PATTERN FOR A SHROUD PANEL—Continued

To avoid complication and confusion we have shown a few of the triangles only in Figs. 4 and 6, but in general practice each triangle will have to be laid out to determine the true length of lines desired. After the descriptions of the operations used in Figs. 4 and 6, with the same principle the remainder of the triangles may be laid out to determine the required points on the pattern, Fig. 5.

C, Fig. 3, represents the contour of the seat bottom at the height of the seat bottom. The pattern is laid out, ever, with the pattern, but is used to determine the line around the shroud in Fig. 2. After the line is obtained, add whatever flanges are desired. The style of construction used, etc.

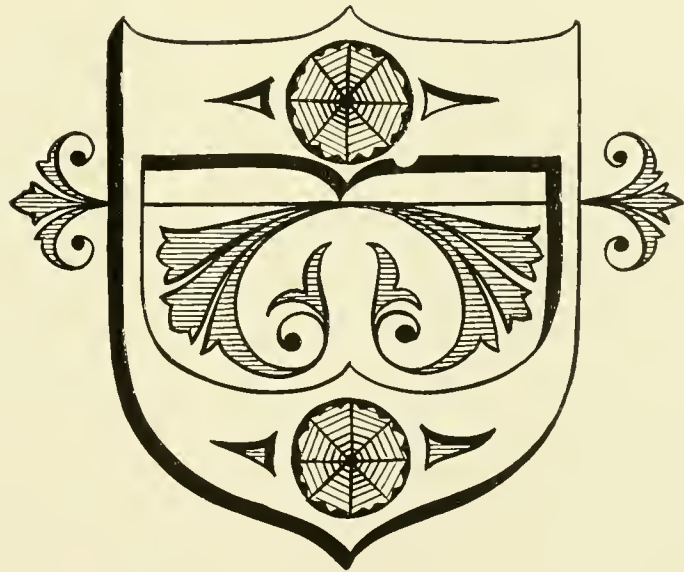

Laying Out Patterns for a Front Mud Guard and Splasher

We illustrate and explain methods used in laying out patterns of a front mud guard and splasher, which are twisted. Fig. 1 is the side view of the front wheel and chassis frame in consideration. Fig. 2 shows the relation of the chassis and shape of splasher where it connects with the running board. Fig. 7 is the plan view of the splasher pattern extended.

To lay out the side view and plan, Figs. 1 and 2, and from these two views, with the aid of the compass, Figs. 2, 3, 4 and 6, we obtain the patterns for the splasher. We explain method of laying out the full pattern of the mud guard splasher, Fig. 5.

The splasher which is the most simple way to form is with a little twist as possible, and with this object in view the surface of the splasher inside of the chassis frame, Fig. 1, is flat and has but one bevel or flare. The distance between points Q and A, and 9 and 10, is the distance the splasher flat.

To lay out points 1 and 5 on the splasher in Fig. 1, we give the splasher a slight twist in order to follow the line of the inside edge of the guard on the chassis. Points Q, 5 and 8 in Fig. 1 it will also be used to form the splasher somewhat to meet the curve of the fender, Fig. 7. The lower end of the splasher joins the running board and chassis frame and is twisted into the required shape. Wherever the surfaces appear it is necessary to space off

points and triangles frequently in order to assure accurate and satisfactory results.

From the front of the splasher to the center or the highest point of the splasher, Fig. 1, let us lay out points 1, 2, 3, 4 and 5. Connect these points with the front of the splasher at O on the bottom, and we will have the necessary triangles for laying out this section of the splasher. From point 5 on the top of the splasher, Fig. 1, space off points 6, 7 and 8 until the fender curve runs into the chassis line, Fig. 1. In Fig. 2 we show the shape of the splasher where it connects with the running board. It will be seen that the end of the splasher here is curved. Lay off a number of equal spaces XI, XII, XIII, XIV and XV on the splasher in Fig. 2, and project same points on to the rear end of the splasher in Fig. 1. Connecting these points 11, 12, 13, 14 and 15 with A, Fig. 1, will give us the necessary triangles for developing the surface of this section of the splasher.

On Fig. 2 we indicate the distance from the inside of the mud guard or running board to the outside of the chassis frame, which distance will be the base of all triangles in Figs. 3, 4 and 6.

In commencing the actual pattern, Fig. 5, take the distance from O to Q, Fig. 1, and lay out on the bottom of the splasher in Fig. 5. This is the true length of the splasher between these points. Take the distance from O to 5 in Fig. 1 and lay it out as the altitude of a triangle in Fig. 3. With the distance from the inside of the guard to the outside of the chassis frame as the base of the triangle, determine the hypoth-

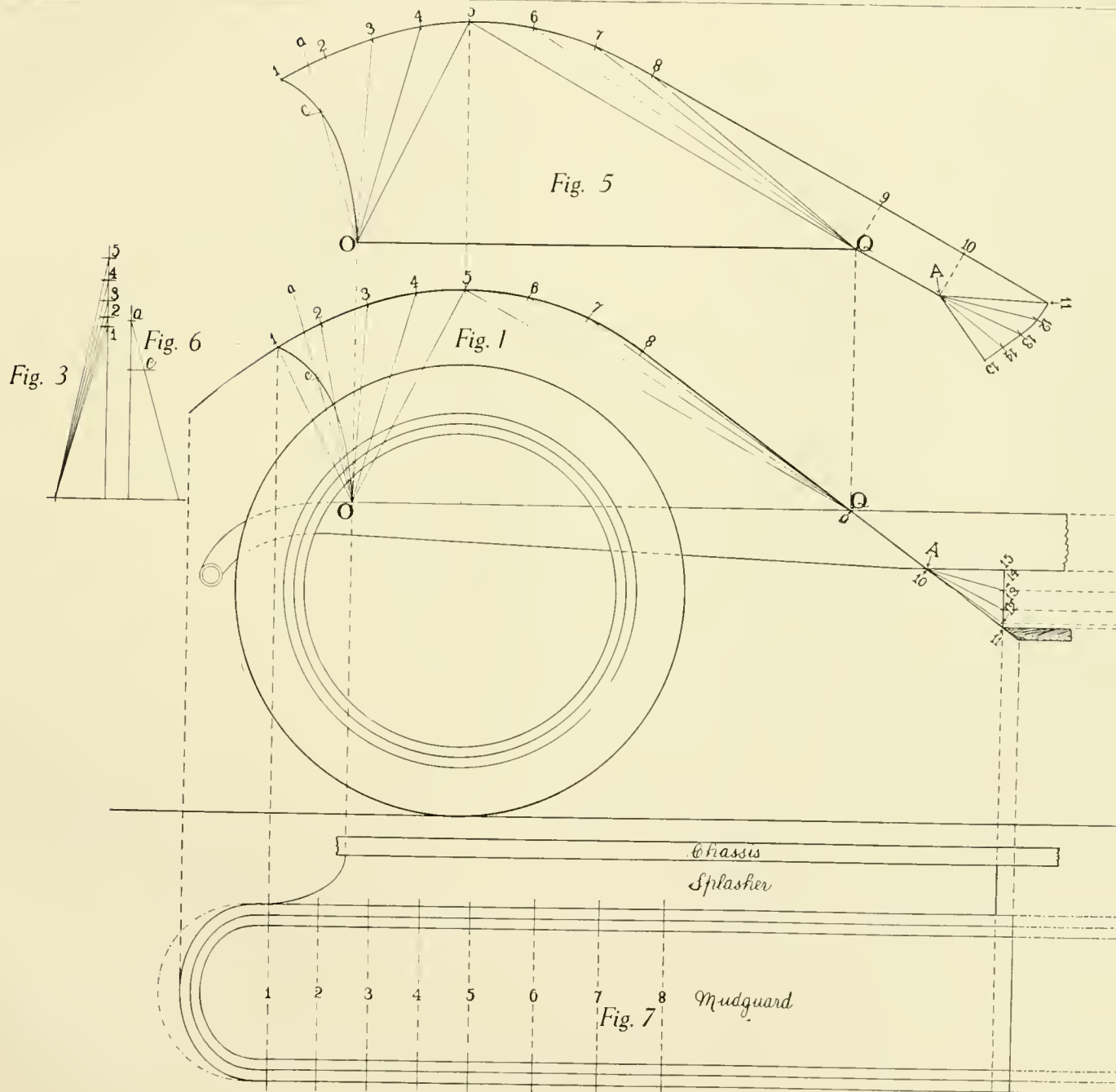

LAYING OUT PATTERNS FOR A FRONT MUD GUARD AND SPLASHER.

Laying Out PATTERNS FOR A FRONT MUD GUARD AND SPLASHER—Continued

length of the line O to 5, Fig. 1. Take this distance as a radius centered at O, Fig. 5.

At the intersection of point 5 on this arc, take the distance from 5 in Fig. 1 and lay it out on Fig. 4 as an altitude, and with a base equal to the distance from the chassis to the inside of the guard, as before, draw the hypotenuse or the true length of the line from 5 to 4. With this distance as a radius centered at Q, Fig. 5, describe an arc cutting the arc described from O at point 4. From point 5 describe an arc with the radius equal to the distance from 4 to 5 in Fig. 1.

At the intersection of point 4 on this arc in Fig. 5, take the distance from O to 4, Fig. 1, and use it as the altitude of a triangle, Fig. 3, and with a base as given, find the true length of the line. Lay it out from point O in Fig. 5 until it intersects the arc drawn from 5 at 4. Likewise space off points 6, 7, 8, 9, 10 on the triangle chart, Fig. 3. Also lay out spaces on the triangle chart in Fig. 4, and find the true lengths of the lines as previously described.

From point 8 in Fig. 5, take the distance from 8 to 9 in Fig. 1 and lay it out from 8, Fig. 5. The intersections of the arcs drawn from Q, equal to the distance from the chassis frame to the inside of the guard, will be points 9 in Fig. 5. From Q to A, and from A to 10, lay out the distance direct from Fig. 1, as this is the true length of the line.

At the end of the splasher we have spaced off on points 11, 12, 13, 14 and 15. Take the distance

from 10 to 11, Fig. 1, and strike it out from 10 in Fig. 5. Using the distance from A to 11, Fig. 1, as the altitude of a triangle, lay it off on the triangle chart in Fig. 2 with the base equal to the distance from the chassis to the inside of the guard or running board.

After having determined the hypotenuse of this triangle, or the true length of the line from A to 11 in Fig. 1, lay it out from A, Fig. 5, until it intersects the arc drawn from 10 at 11. Space off the distance from 11 to 12, Fig. 5, taken from XI to XII in Fig. 2.

We now want the true length of the line A to 12 in Fig. 1 in order to enable us to locate the intersection of point 12 in Fig. 5. With the distance from A to 12, Fig. 1, as the altitude of the triangle, lay same off in Fig. 2 with the base obtained by squaring up point XII in Fig. 2 until it strikes the horizontal line at the top of the chassis frame. With the base and altitude given, it is easy to determine the hypotenuse of this triangle, which should be described as a radius from A in Fig. 5 until it intersects the arc drawn from 11 at 12, and so on with points 13, 14 and 15, being careful to obtain the correct base of each triangle in Fig. 2, inasmuch as the base of each triangle is ever changing on account of the splasher running closer to the chassis at each point.

Fig. 7 shows the actual plan view of the mud guard, splasher and chassis, as projected from the side view in Fig. 1. The extended dot and dash lines show the developed surface or pattern of the mud guard as taken by measuring the distance from point to point around the profile of the guard in Fig. 1.

Perspective Drawing of Vehicles

IN THIS article we illustrate and explain a system of perspective drawing for automobiles and carriages. In making perspective designs of vehicles it is always desirable to lay them out so that the dimensions of the body can be scaled from the profile of the drawing.

For instance, if one desires to know the width of the door, the depth of the seat, or the height of the job, he can readily obtain the measurements from the profile of the drawing.

In this case the vehicle will not be set up in true perspective, but the effect is as pleasing as if it were. If the job were drawn in true perspective it would not be possible to scale any measurements from the drawing, and it is not necessary for draftsman or designer to be familiar with true perspective drawing in order to become efficient in carriage perspective. The system explained herein will be found to be very simple, and once the designer masters the system, he will find that it will be of great value to him, inasmuch as he will be able to produce rapid and more pleasing results.

In preparing a perspective drawing, the first operation is to lay out the true side view or elevation of the vehicle, as shown in Fig. 1. Next determine the vanishing point, which in this case is to the front of the coupé pillar nineteen feet on the line of vision, but this distance is taken arbitrarily, and after once determined satisfactorily, may be kept as a standard. The line of vision is usually five feet three inches from the base or the ground. The vanishing point is not shown on the drawing, as it would extend far out from the edge of the paper or the ordinary drawing board. Instead of showing the vanishing

point, we illustrate a more satisfactory method of drawing the vanishing lines. Fig. 4 represents the vanishing point as a center. This arc should be drawn on a board of light wood, and then it may be transferred to the drafting board with two compasses, as shown in Fig. 4 by a and b.

Fig. 7 represents a lightly eccentric blade, that is, the top edge is not perpendicular with the center of the blade. If a square is set square on the arc as shown, we can draw a line that will vanish at the vanishing point.

If the widths of the body are known, it is possible to draw the front and back views, Fig. 5. This is shown here by way of illustration. Once the draftsman becomes accustomed to this method, the T square will be eliminated to a certain extent.

With T square 7 set on the inclined line A passing through the center of the wheel at the base. Let this line continue to the top of the drawing. After this, draw another line through the center of the near rear wheel. Drop a perpendicular line from the top of the wheel until it strikes the inclined line A at point B. If that the wheel tread is 56 inches, the radius from 2, describing an arc un-til it strikes the inclined line B at II, Fig. 8. By connecting the center of the wheel with straight line c we will have the line of vision. The widths should be laid out.

PERSPECTIVE DRAWING OF VEHICLES—Continued

sents a triangle, the angle of which is about
d which angle is used for all penchant lines,
e offside points or the amount of perspective,
n at will, and, of course, regulates the amount
After the draftsman has made a few drawings
which angle is the most satisfactory and pro-
leasing drawing, and adopt it as a standard
gle.

off rear wheel, draw the penchant line *i* with
e. 5, from point 2 on line A, Fig. 8, until
B. This gives us the base of the off rear
the vertical center line, and use the T square
Fig. 4 for finding the horizontal center and

the perspective of any part of the vehicle
narrower than the wheel tread it is necessary
center line, Fig. 8. The center line is obtained
wheel tread on line *e* at *x*, from which point
drawn with the T square Fig. 7 on arc Fig. 4.
e, if the perspective on the coupé pillar is
width from the center line, Fig. 2. Lay it
the center line in Fig. 8 on line *e* at *V* and 5.
e Fig. 7 on arc Fig. 4, draw lines from these
ough Fig. 8. Square down near side of coupé
at until it strikes line 5. Use the triangle,
the penchant line *D* until it strikes line *V*.
line from this point on to Fig. 1, and this
le of the coupé pillar at the front. Take the

T square Fig. 7 on the arc Fig. 4 for laying out vanishing lines
and obtaining points on the offside of the coupé pillar which
should correspond to points on the near side of the coupé
pillar, and so on with 3, 4, 6, 7, 8 and 9, Fig. 8, which represent
the widths of the body taken at different points on Figs. 2
and 3, and *D*, *E*, *F*, *G*, *H* and *i* represent penchant lines for
obtaining the perspective at these points.

Fig. 9 shows how the vehicle would appear in looking down
upon it from above. The near side produces a perfect side
view as in Fig. 1. Fig. 9 is, of course, false, as the ear could
not be twisted as shown in Fig. 9, but this is the way the
perspective is set up in the profile or elevation, Fig. 1.

Fig. 10 illustrates approximately how the plan would
necessarily have to appear if the elevation or side view, Fig. 1,
was in true perspective, and is laid out here by way of illus-
tration to show the difference between true perspective and
the system of perspective taken up in this article.

Referring to these two figures, 9 and 10, compare the
wheel base on the near side of the vehicle, and it will be noted
that the wheel base in Fig. 10 is greater than that in Fig. 9,
showing that anything in true perspective set at such an angle
will appear shorter than it really is, and, if drawn that way,
will not permit of the taking of any measurements from the
side of the vehicle, as explained previously. In Fig. 9 the
reader will note that the wheel base on the near side is the
same as that of the wheel base in the elevation of the vehicle,
Fig. 1, therefore making it possible to scale this dimension and
others direct from the side view or elevation, Fig. 1.

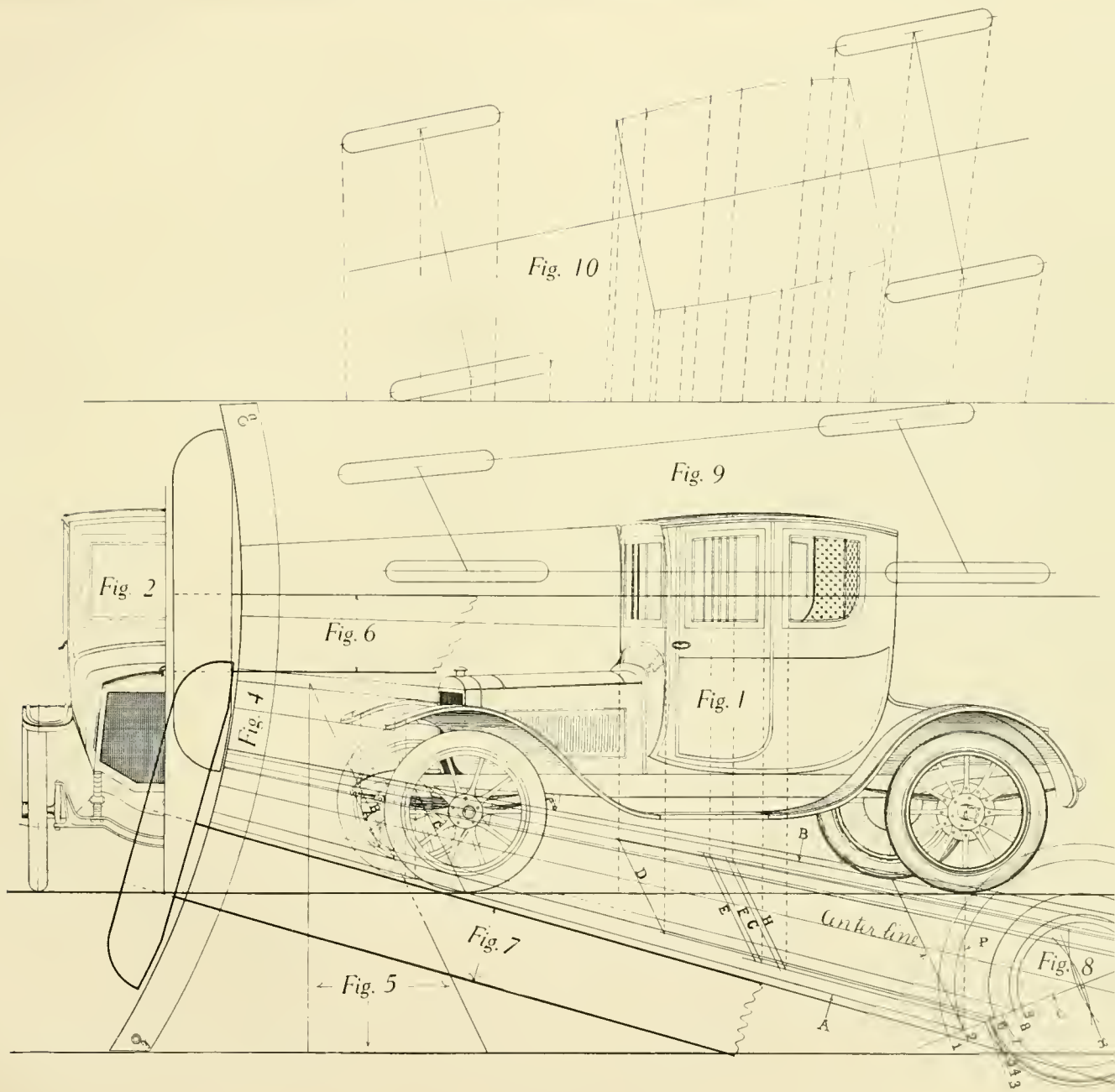

PERSPECTIVE DRAWING OF VEHICLES.

Coloring Carriage and Automobile Drawings

vehicle designs, be they carriages, automobiles, in fact, anything in vehicle construction, a carriage, or, we may say, rules, must be followed to good proficiency to be successful. Besides, consequently, after the rules are known, must be had to the artist in this particular line. Of course, different roads lead to the same end. One road may be longer than the other, but, after the rules are known, the artist may know as how to get quickest to the road's end.

Some designers who have taken lessons in coloring, and experienced artists may differ from our practice, but, after all, when the first rules have been studied, success will depend more on practice to obtain results which is admired even by those who have handled the matter years.

The elevation of any vehicle, carriage, automobile, drawn in perspective is acknowledged to be a representation to show buyers, or to print in catalogues in perspective, most of the details contained in the design are shown, but keeping in mind always that a drawing must be retained to represent the style to produce good colored drawings which are advertisements a great inducement to add this accomplishment which will aid one not only to add taste to his work but also furnish an opening to secure a better

instruments, the best kind, are necessary, also to have a variety of brushes, and an assortment of bristol boards and kinds of fine drawing papers, including tracing

papers, water colors, Winsor and Newton have had a good reputation, but a great variety of cake and tube colors obtained from stores where artists' materials are sold. The best colors are white, brown, blue, green, yellow, and deep gray, but, of course, by buying a whole box you are in the box that may be needed. India ink is also a necessity. Some prefer Higgins' American

make, while others prefer the French make, but both are of excellent quality.

Pen drawings, uncolored or colored, should not be drawn directly on bristol board or any other kind of drawing paper, but should be made either on thin white paper or the regular tracing paper. Mistakes in outlining carriages and automobiles are unavoidable, and, therefore, must be erased, and the surface of the very best drawing paper that is made will be damaged with the eraser, and defects show through the colors. After the sketch is done, it is blackened on the rear side, that is, the reverse side from the drawing. For this, dry lamp black is used. Others save the dust from the pencil sharpener. To obtain the dust, they use a small box with a flat file on top. The file is used as a pencil sharpener, and the dust drops in the box, and is kept in the box until needed.

Most artists use red chalk known as "rouge." Some of the black dust will adhere to the paper where not wanted, and it is difficult to remove it, while the rouge is more easily erased. When the sketch is finished and reddened on the rear side of tracing paper, it is put on the bristol board, fastened with thumb tacks, and all the lines are then gone over with a 6-H Faber or Hardtmuth pencil with a sharp point. Others use a needle or tracer, which will be found among the drawing instruments. By this process, a clean, correct reproduction of the design is obtained, and at the same time the draftsman has a copy for future use.

The foreground of the object must be drawn first, which, on a carriage or automobile, means the wheels on the near side. Each object or part of the vehicle is thus drawn, one after the other, and the last part to be drawn will be the off wheels. At the same time, the required colors must always be kept in mind. If the gears are yellow, and striped black, the face of the spokes near the hubs have generally two fine black lines, also one or two fine black lines on the rim faces, and tires black.

In such a case, the hubs, spokes and rims are colored first, and black lines drawn on top of yellow, and all colors are worked the same as India ink. For making small lines on gear or body, also

. **COLORING CARRIAGE AND AUTOMOBILE DRAWINGS—Continu**

scrolling, use a lady's pen. In fact, a lady's pen is very handy for all kinds of lines, even the straight lines. Lines of various thicknesses can be made by more or less pressure, thus avoiding the unscrewing of drawing pens.

Working with a lady's pen requires considerable practice, but, when once mastered, it is a great advantage, and considerable time is saved thereby. A colored plate can not be made except all the outlines are drawn with the required color of the ink. If the gear is yellow, the outlines must be of the same color, and if the body is blue, the outlines are blue, if the colors are of a darker shade. Otherwise, if a light shade, the outlines require a fine black India ink line.

To start the color on bodies, if there is black, such as rockers and boot panels, use Winsor and Newton's lamp black, to which, after being rubbed up to a rather thick liquid, add a very little dissolved gum arabic. To know whether the color has the proper consistency when rubbed up, tip the cup. If right for use, the color must flow slowly. To make all outlines sharp, run them over twice with lamp black with the drawing pen, and fill the rest of the panel between the lines. For the small and narrow black spaces, thin down the color somewhat, otherwise it will have a too heavy appearance. For the rest of the panels, that is, the large spaces, the brush is used, but care must be taken to distribute the color properly.

The painting of the body in coach body colors is exceedingly difficult, and requires considerable practice, as very few of the water colors have sufficient body to cover well. Lamp black, Prussian blue, vermilion and Indian are the only ones having good coloring properties. Most artists require transparent colors, while for carriage, coach and automobile work they must cover the surface at the first stroke, as only a few colors will allow a second coat. Carmine and ultramarine are the only ones, and it requires great care and considerable practice to produce a uniform surface after several coats. Perfect work cannot be

produced with imperfect colors, but made just for this work, which cover application, can be bought in first-class

Colors of this kind must be rubbed evenly as explained for lamp black, freely, but with extreme uniformity not be retouched, as it will show de

The striping, which gives finish ing, is used either to cover the edges, and is done with the drawing pens, lady's pen, and one that has been used, as a new pen is too sharply pointed. The colors for striping are million, white, yellow, orange, chrome a combination of the above colors.

After the striping lines have been body, prepare lamp black, which flow very fine line under, or right and left sending the shade for the striping they are tufted; lower part darker a part can be imitated from clear, well tone illustrations. Make handles, or gold, but as these are generally pared to be suitable for this work. it into a saucer, and allow it to stand water which rises to the surface, a arabic gum water, stir well, and apply dry, burnish with a thin bone with ro burnt sienna.

A great deal more could be said above explanation is about the whole order to be successful, do not mind greatest care and the very best material essential points.

Working Drafts

DRAWING working drafts represent nearly every automobile body, and should be of great service reference for designs, etc. They are accurately working scale. The different views are kept clear which makes them easy to follow. Usually, on account of having to make shop working it is necessary sometimes to lay out one view on

Large draftsmen and men who can lay out and from the draft are in good demand, and are paid men in the trade.

To make a complete working draft of a carriage body requires considerable skill and experience. For beginners is to practice free-hand drawing and to obtain good, true lines, not depending on tools. Scale drawing is very good practice.

Experience obtained by practical work in the body shop. This will give the student a better understanding of the construction required on a draft.

Lines taken up in this book should be thoroughly understood as to be able to apply them correctly. Aim to make as plain and simple as possible, putting on only working lines, as any unnecessary lines confuse as well as waste the draftsman's time.

Construction lines and connecting lines shown in the problems in this book should not be on the working drawing. If needed to obtain the desired points, they should be removed. They are shown in the problems for reference. It is sometimes better to work out the problem on a separate plate from the working draft, and make a duplicate of the line obtained and transfer same to the draft, thereby obviating the erasing of lines and the marring of the face of the draft.

In a working draft the base line of the body is generally the center line of the half bottom view, therefore the center lines of the half bottom view must be drawn on the elevation. This is apt to confuse a beginner,

and is one of the reasons for our caution against putting on unnecessary lines.

Before one can make a working draft of a body, he must have a general idea in his mind of what he is to draw. It is best to first make a small scale drawing, or put the design on a blackboard, where it can be looked over and changed if desirable. The proportions of a vehicle can be studied better from a blackboard.

Special attention should be given to the full-size draft board and tools for making a draft. Well-seasoned soft pine is the best material for the board, which should be made large enough for the full size of the body. The board should not be less than $7\frac{1}{2}$ " thick and jointed and glued up well. Hardwood cleats should be placed under the board, not fastened directly to it, but so as to allow the boards to expand and contract without warping. Have all edges planed off square. This is very important to insure accurate work. If the draft board is made so that it can tilt at any angle, it is more convenient.

The best of drawing instruments, squares, triangles and curves are necessary. It is also desirable to have a bench and vise at hand, so that the different patterns or sweeps may be made as desired. In making these patterns or sweeps, great care must be taken to get them smooth and true, using the eye to ascertain, by sighting along the edge of the sweep.

It is customary to lay out the near side of the body or the left side elevation first. Outline the body in all views as much as possible, and then fill in the detail and construction. Always aim to keep the body as light in weight as possible, consistent with strength, as unnecessary weight in the construction of any vehicle is undesirable.

Provisions should be made to accommodate locks, hinges and other hardware. The ironing and trimming should also be considered.

And so we could go on indefinitely giving advice, but most of these things must be learned by experience. So we advise the beginner to "stick to it" and put forth his best effort in all things. Perseverance and careful work will lead to success.

PRACTICAL PROBLEMS FOR VEHICLE DRAFTSMEN AND MECHANICS.

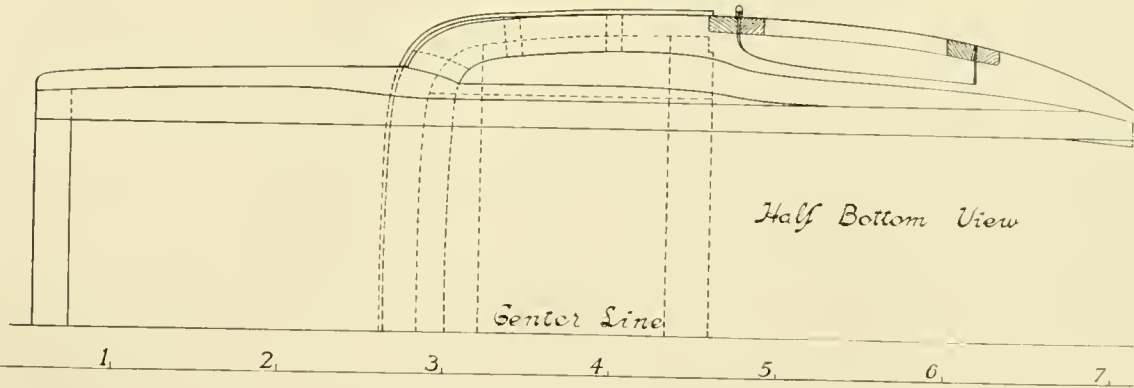
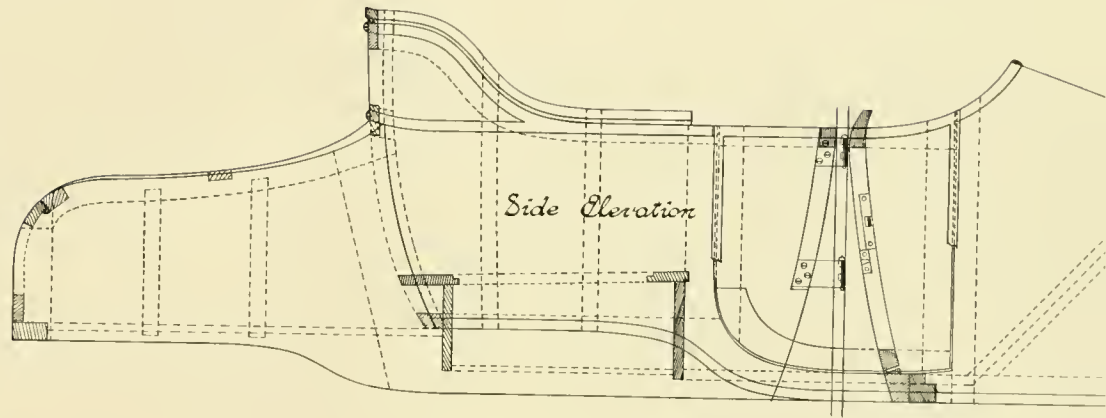
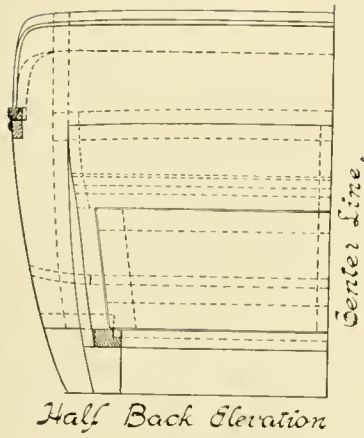

WORKING DRAFT OF TORPEDO ROADSTER.

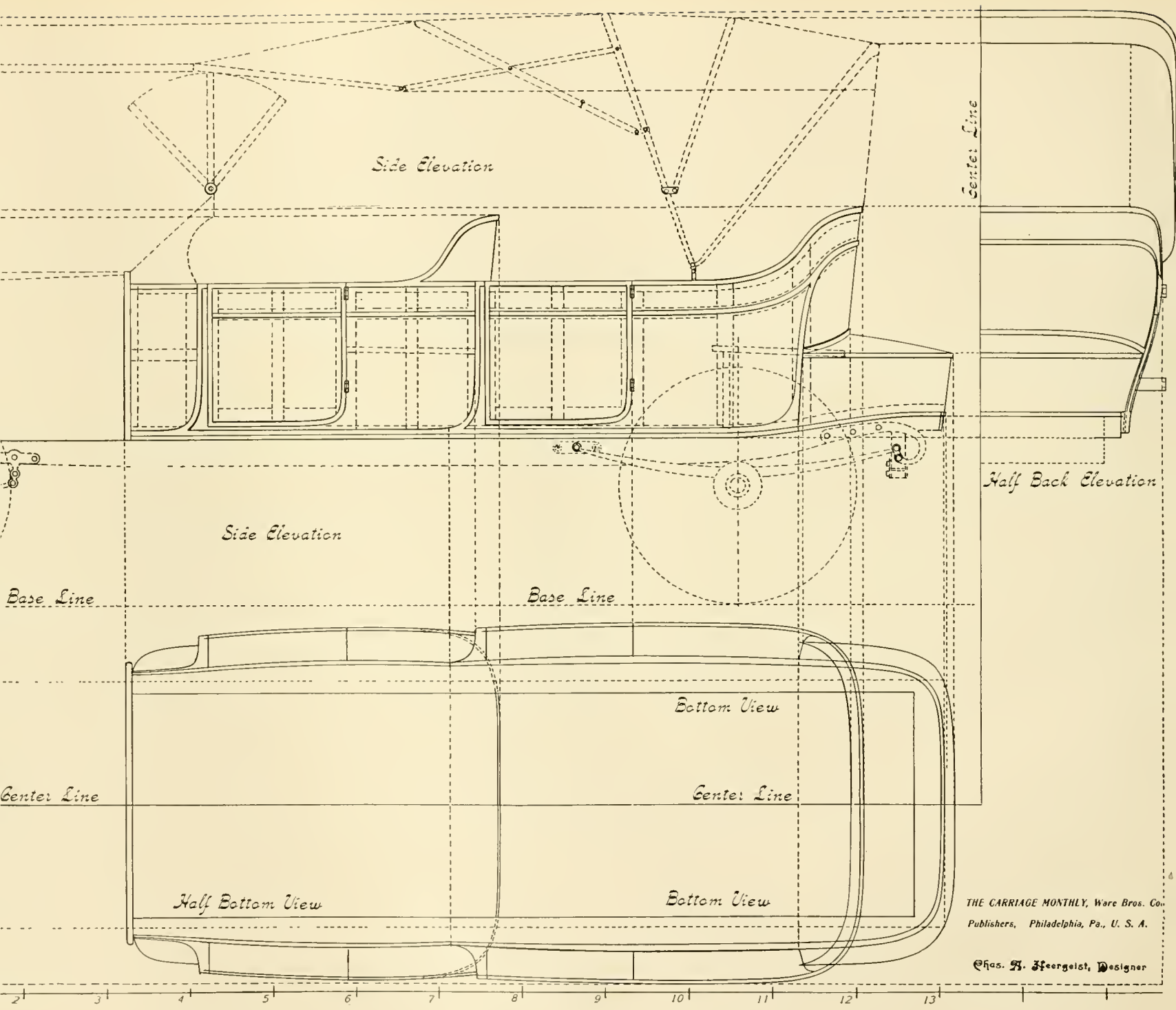

NEW DESIGN OF TORPEDO BODY, WITH CONVEX-CONCAVE TURN-UNDER.

THE CARRIAGE MONTHLY, Ware Bros. Co.
Publishers, Philadelphia, Pa., U. S. A.

Chas. H. Feergelst, Designer

PRACTICAL PROBLEMS FOR VEHICLE DRAFTSMEN AND MECHANICS.

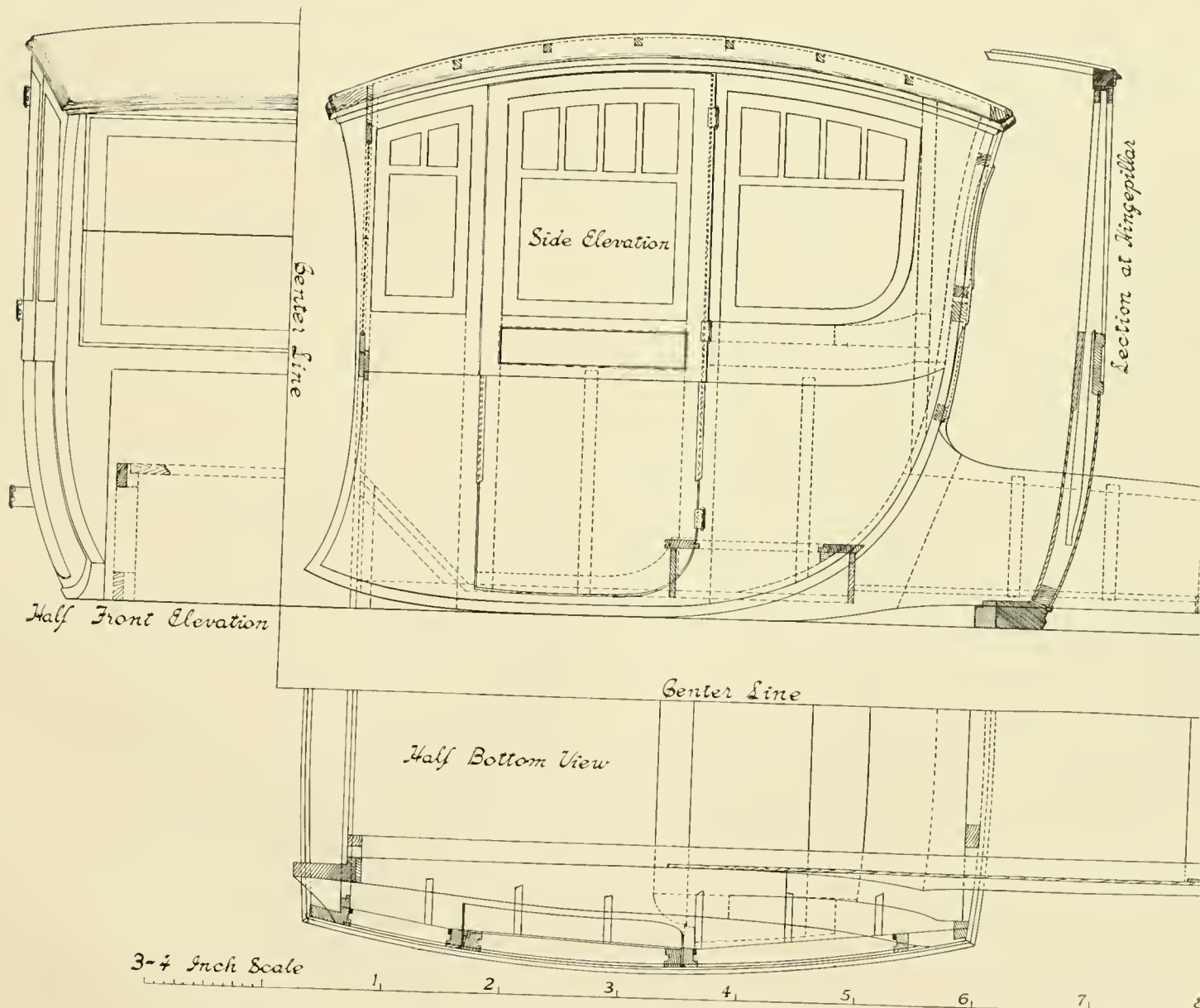

WORKING DRAFT OF COLONIAL COUPÉ.

PRACTICAL PROBLEMS FOR VEHICLE DRAFTSMEN AND MECHANICS.

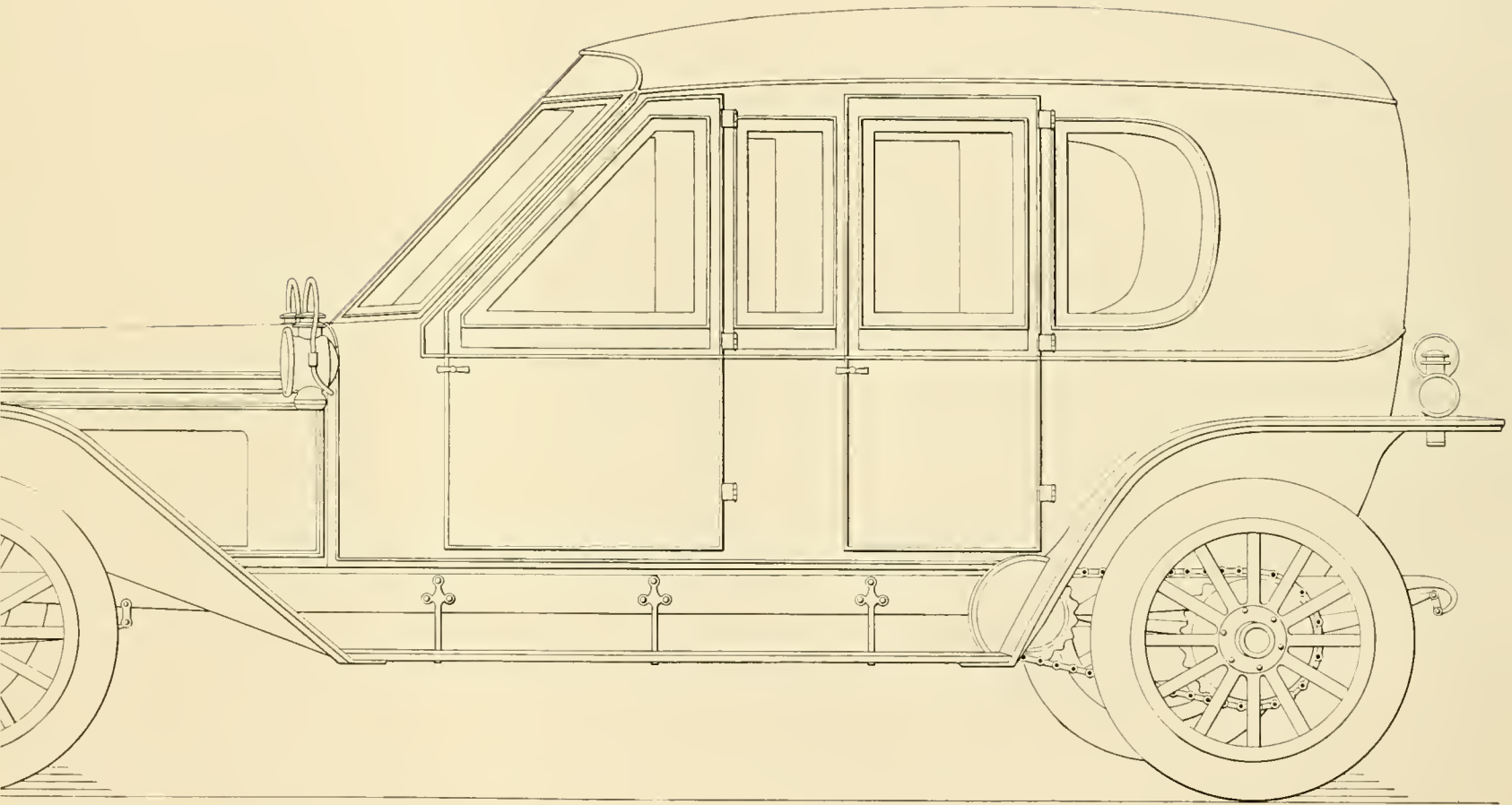

2 | 3 | 4 | 5 | 6 | 7 | 8 | 9 | 10 | 11 | 12 |

FOUR DOOR LIMOUSINE WITH REAR ROUNDED CORNERS AND ROUNDED TOP.

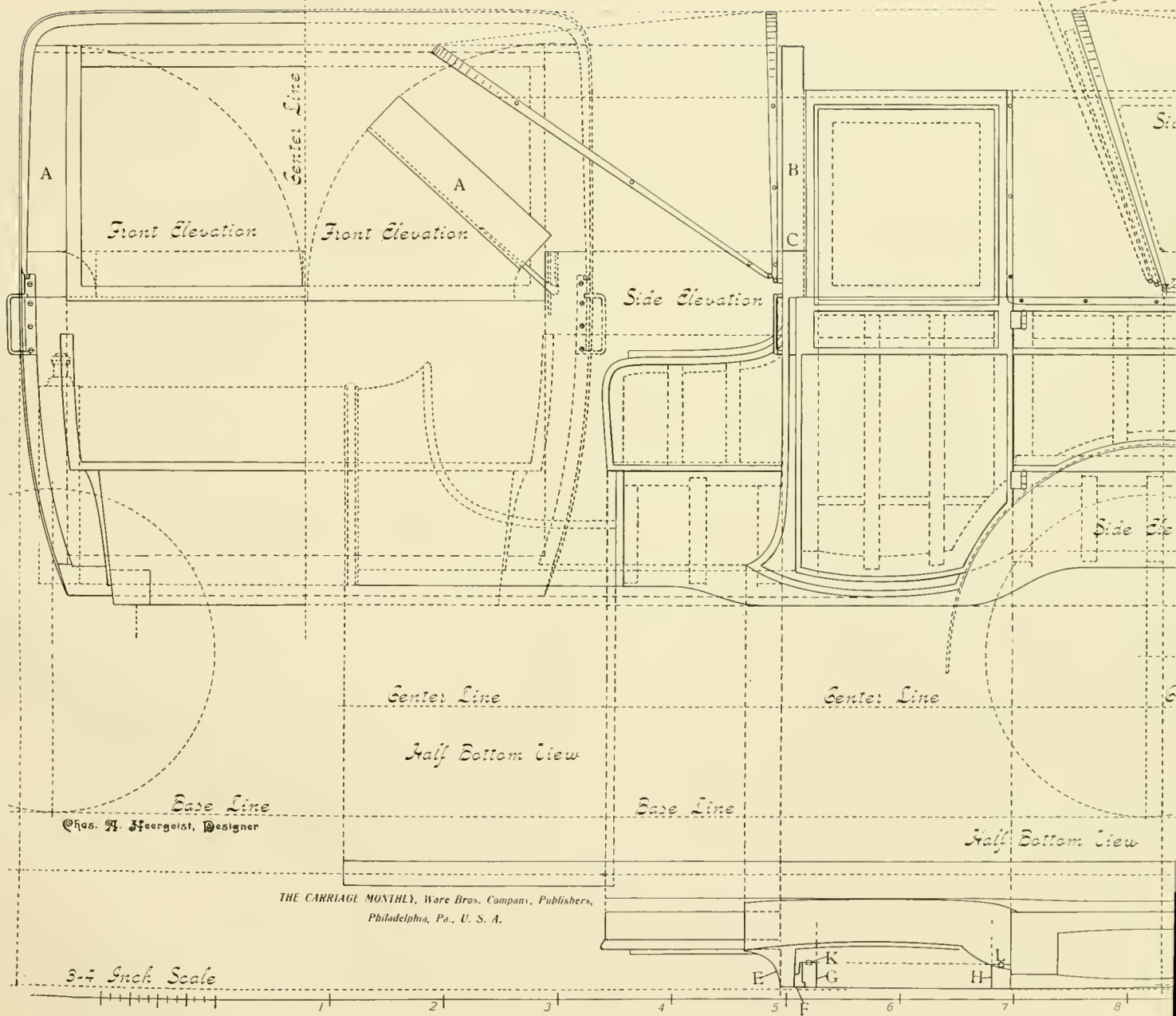

WORKING DRAFT OF TOURING CAR BODY, WITH NEW FOLDING TOP, DROP CHASSIS, ILLUSTRATING FRONT, SIDE AND BOTTOM VIEW.

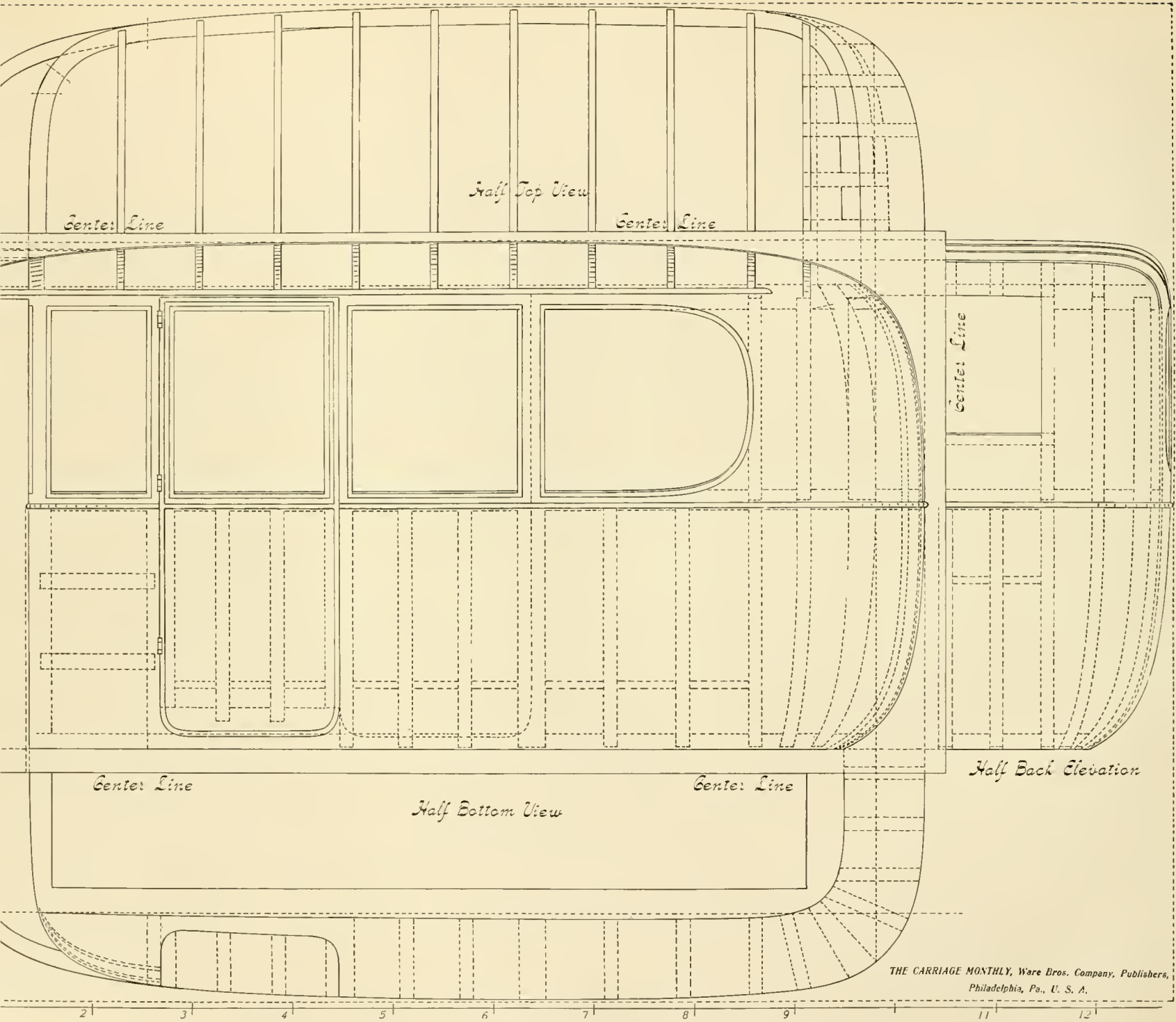

THE CARRIAGE MONTHLY, Ware Bros. Company, Publishers,
Philadelphia, Pa., U. S. A.

WORKING DRAFT OF LIMOUSINE BODY WITH ROUNDED ENDS AND SWELL SIDE SURFACES.

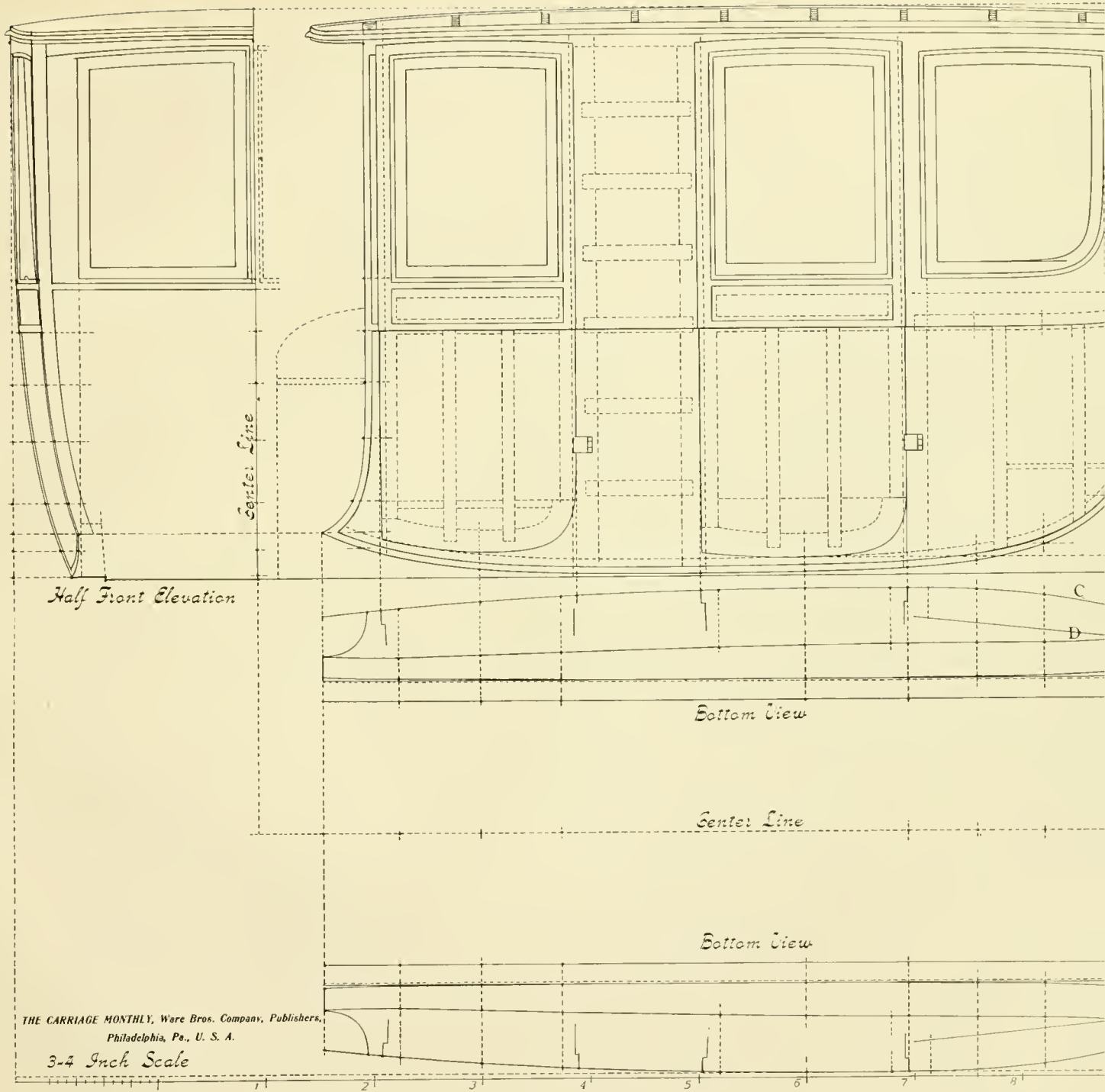

FOUR DOOR CLOSED LIMOUSINE BODY WITH REAR SQUARE CORNERS, FITTED TO A ST

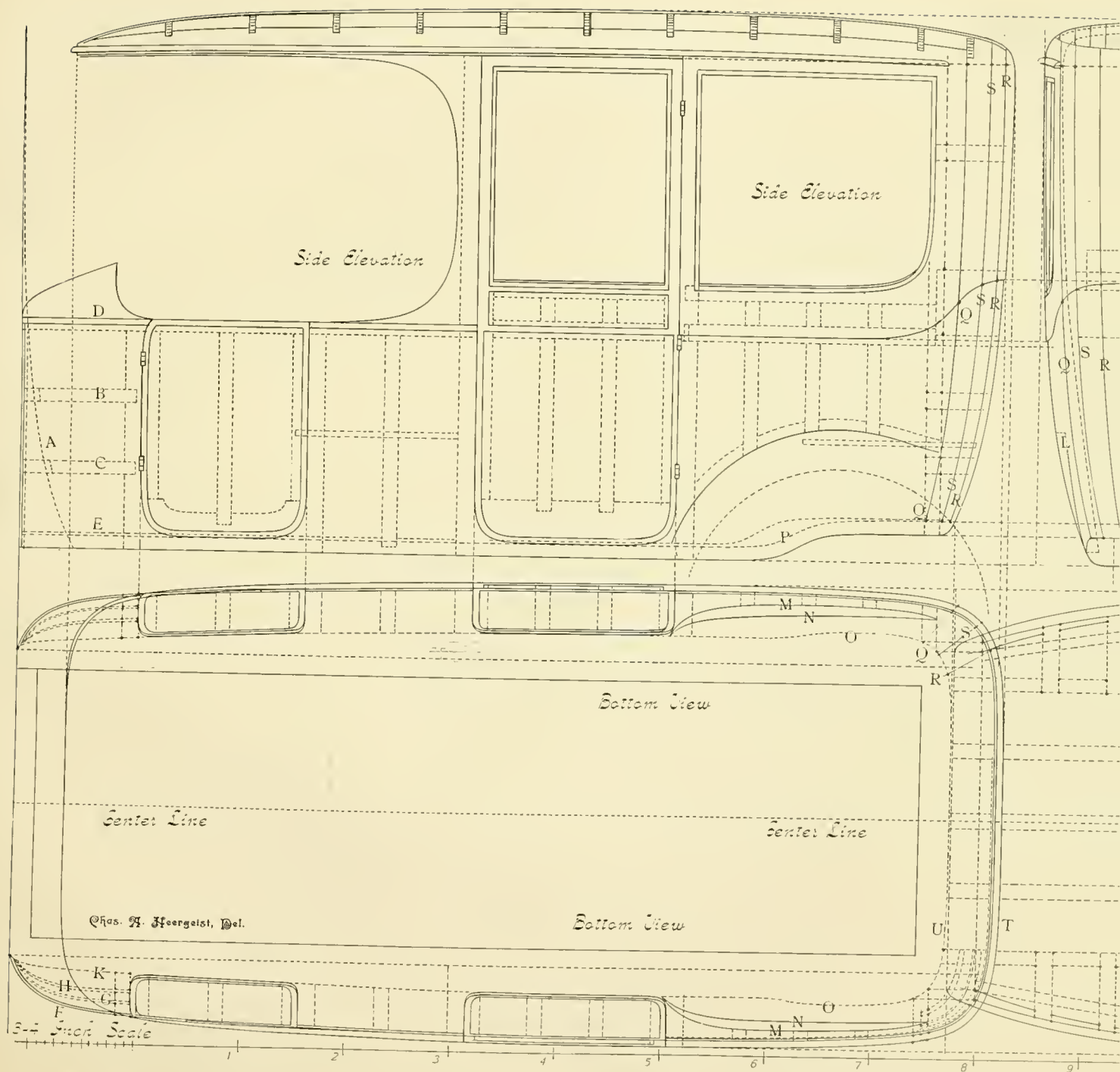

TWO LOW AND TWO HIGH DOOR LIMOUSINE BODY WITH SOLID ROUND CORNERS AND ROUNDED TOP, FITTED

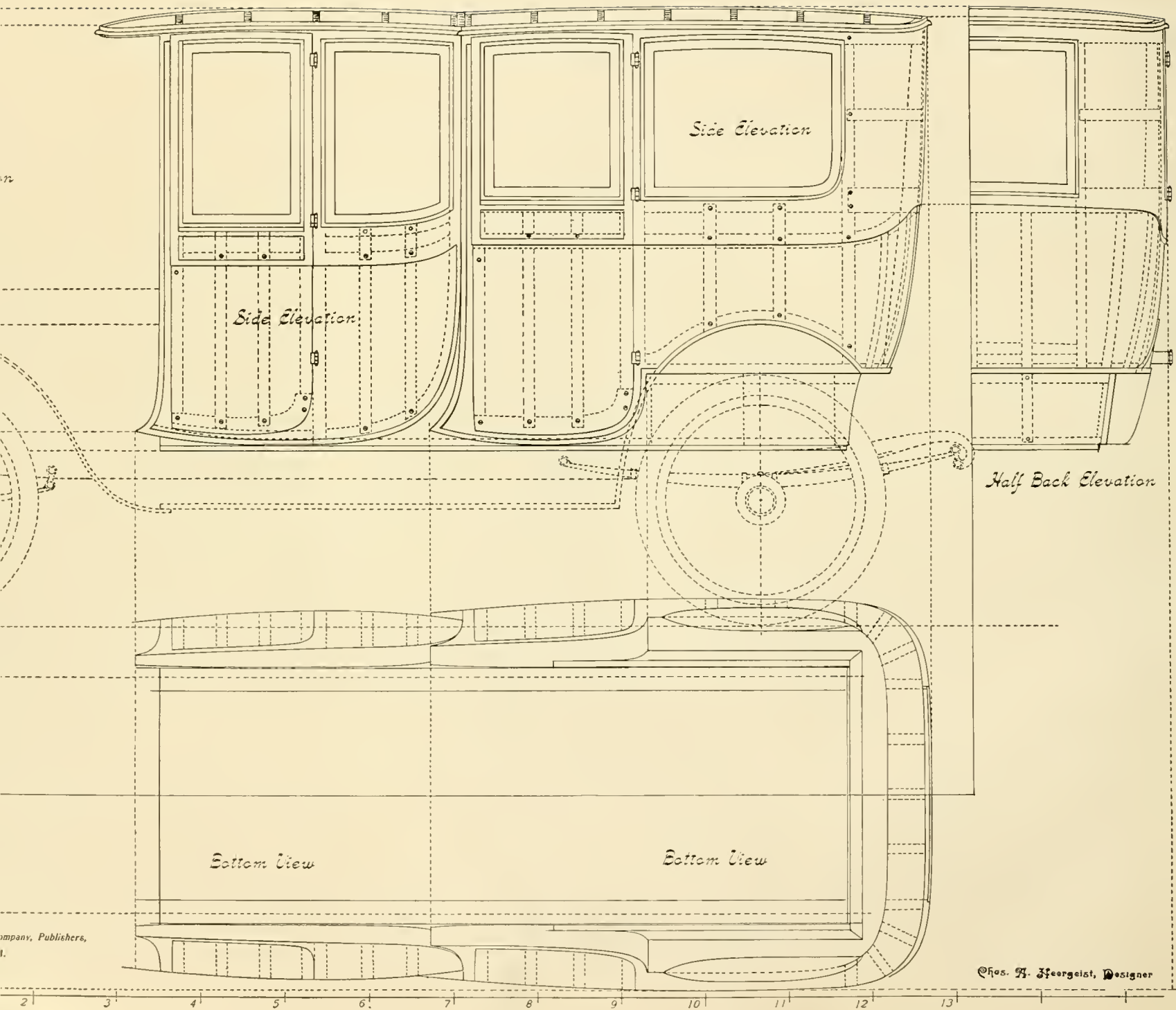

Company, Publishers,
1.

©Hos. H. Feergeist, Designer

DRAFT OF AN EXTENSION-FRONT BROUGHAM BODY, SHOWING SIDE ELEVATION, HALF FRONT AND HALF BACK ELEVATION AND BOTTOM VIEW.

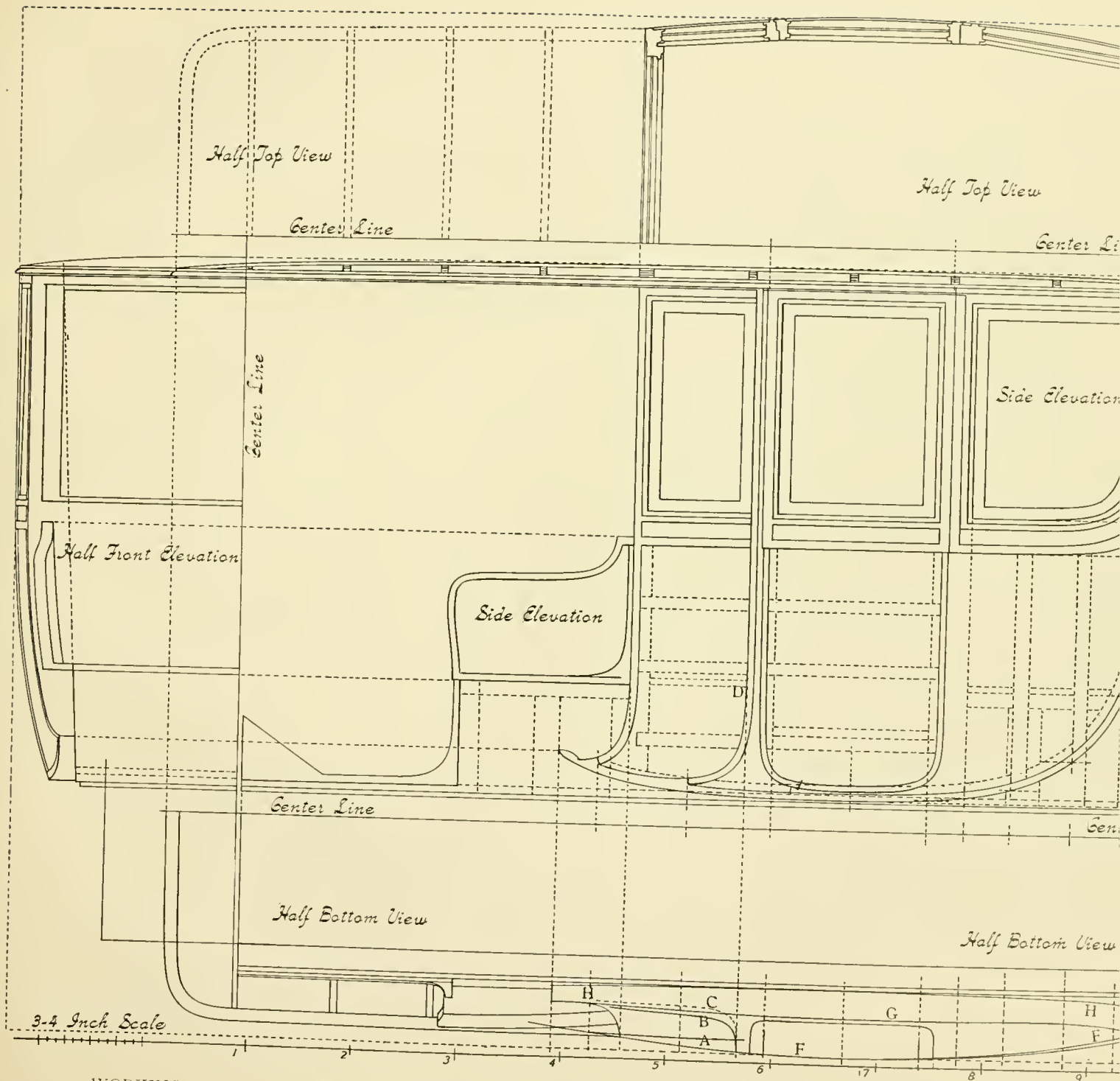

WORKING DRAFT OF LIMOUSINE BODY, WITH ENCLOSED FRONT AND ALL GLASS FRAMES TO DROP; ILLUSTRATION OF HALF FRONT AND HALF BACK ELEVATION AND BOTTOM VIEW.

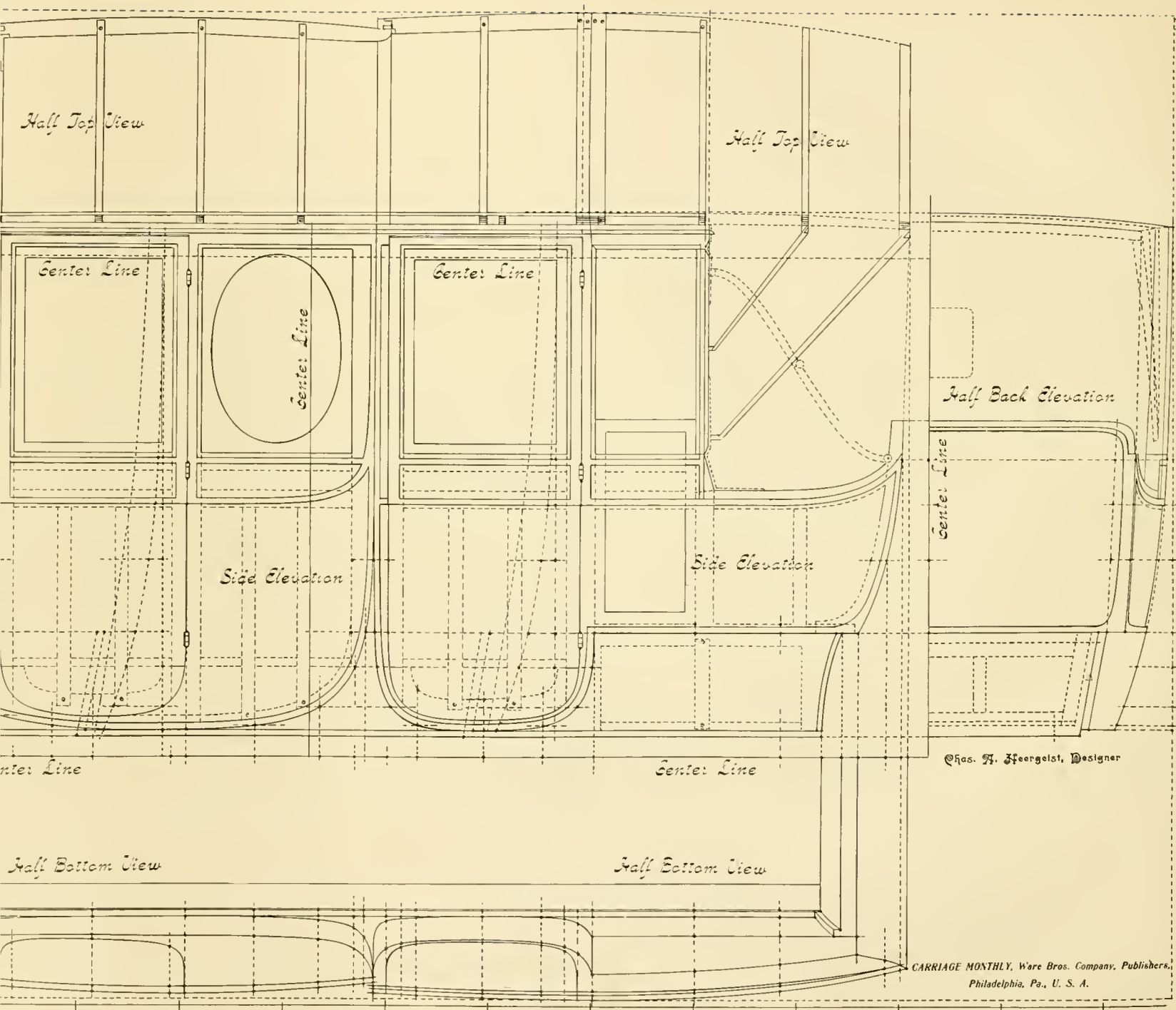

MOUSINE-LANDAULET BODY, WITH ENCLOSED FRONT AND ALL GLASS FRAMES TO DROP; ILLUSTRATING HALF TOP AND BOTTOM VIEW, HALF FRONT, HALF REAR AND SIDE ELEVATION. BODY BELOW SIDE QUARTERS IS RECESSED.

One copy del. to Cat. Div.

FEB 12 1912

LIBRARY OF CONGRESS



0 018 455 374 0