

S 685

.05

Copy 1



The
Oliver
Plow
Book



The OLIVER PLOW BOOK

Paper Bound can be secured as follows:

SINGLE COPIES	\$ 1.00
PER DOZEN	10.00
LARGER QUANTITIES, per doz.	9.00

COPYRIGHT 1920
BY
OLIVER CHILLED PLOW WORKS
SOUTH BEND, IND.
U. S. A.

**The
Oliver
Plow
Book**

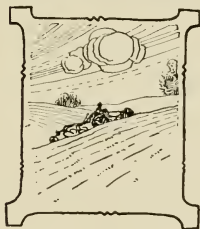

**A Treatise
on Plows
and plowing**

**Published by
Oliver Chilled Plow Works
South Bend, Ind.**

MAR 10 1920

© CIA 564710

no 1

Preface

THE treatment of any farmer's soil is entirely within his hands. Success is measured by his knowledge and the diligence with which he applies those laws of Nature which are related to crop growing.

These laws are universal. A farmer can apply them to meet his own particular need better than acting upon the advice anyone can give him, because he understands his soil conditions. Other people do not.

The purpose of this book is to set forth these laws and explain the causes and effects.

The Oliver Chilled Plow Works has a desire to be of practical value to farmers. Our long experience in building plows and kindred implements for use all over the world has given us an opportunity to observe a great many facts in connection with plows and plowing which should be common knowledge among farmers.

OLIVER CHILLED PLOW WORKS.

CONTENTS

<i>Chapter</i>		<i>Page</i>
I.	Functions of the Plant Organs	5
II.	Influence of Water	14
III.	Importance of Air in the Soil	27
IV.	Soil Temperature	32
V.	Why Soils Must Be Handled Differently	37
VI.	Depth of Plowing	51
VII.	When to Plow	63
VIII.	Plowing to Kill Insects	72
IX.	Plowing to Kill Weeds	79
X.	Plowing Under Green Manure	87
XI.	Judging Plowing	92
XII.	Plow Bottoms	97
XIII.	Plow Bottom Metals	129
XIV.	Scouring Troubles	137
XV.	Setting the Share on the Plow	149
XVI.	Sharpening Soft Center Steel Shares	154
XVII.	Sharpening Crucible Steel Shares	158
XVIII.	Sharpening Chilled Shares	159
XIX.	The Rolling Coulter	160
	The Jointer	
	The Combined Rolling Coulter and Jointer	
XX.	The Tractor Plow Hitch	167
XXI.	Adjusting Horse Plows	183
XXII.	Middle Breakers	189
XXIII.	Disk Plows	195

CHAPTER I

Functions of the Plant Organs

THERE is a vast difference between operating a farm and a factory. The process of manufacture from the receiving of the crude materials to the finished product is entirely in the hands of the manufacturer. That is, he can control every step in any process from start to finish. It is not so with the farmer. The farmer can control only the operation of the machinery. He has to have a partner to enable him to successfully grow crops. That partner is mother Earth. He has to depend upon her for everything except the labor, which is his part of the contract.

Obviously the farmer who succeeds best must understand Nature. It is a hopeless task to learn all the whims and caprices of Nature, but it is possible to learn how to treat mother Earth so that she can use these whims and caprices of Nature to bring forth bountifully.

The first step in this process is plowing. Many important historical events offer the strongest evidence that from the time man first began to till the soil he discovered the necessity for stirring it in some manner before any kind of a crop could be grown. Even the greatest authors of antiquity, medieval and modern times, speak of plowing. We have Benjamin Franklin in our own colonial times who advised farmers "to plow deep while sluggards sleep and you will have corn to sell and keep." Pliny spoke in his treatise on agriculture,

of the importance of having the ground properly prepared, and even in the New Testament, in the book of St. Luke, the parable of the sower forcibly illustrates that Christ was a keen observer of the laws of Nature as related to crop growing.

“A sower went out to sow his seed; and as he sowed some fell by the way side; and it was trodden down, and the fowls of the air devoured it.

And some fell upon a rock; and as soon as it was sprung up, it withered away, because it lacked moisture.

And some fell among thorns; and the thorns sprang up with it, and choked it.

And other fell on good ground, and sprang up, and bare fruit a hundredfold.”

This quality to observe conditions as they are is just as fundamental to the business success of any man as it is for his religious welfare. There is not such a tremendous amount of difference.

Evidently farmers in Christ's time believed that it was necessary to kill the thorns and to conserve moisture, and they believed still more that it was necessary to have the ground “good.” This word “good” involves a great deal. Our modern soil phycisists tell us that we plow to kill weeds, conserve moisture, and to put the ground in a good condition of tilth. By tilth they mean that the land is in shape to be cultivated easily and in such condition as to bring forth abundantly.

Before one can put ground in condition to meet plant growth requirements he must have a thorough understanding of the habits and characteristics of plants he desires to grow, the kind of food that plants require and

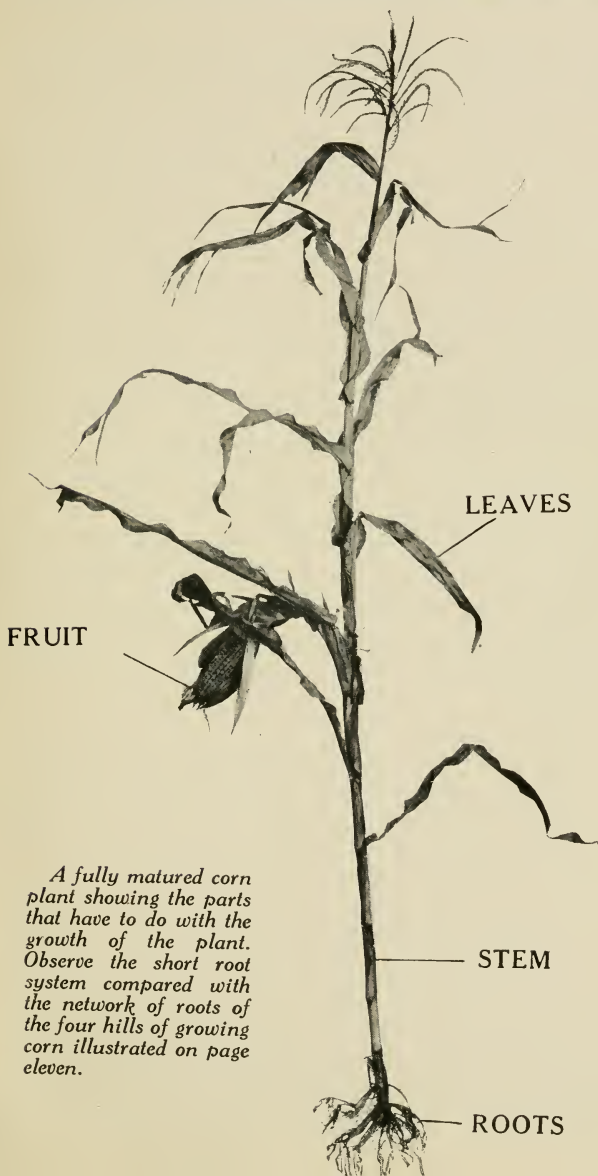

A fully matured corn plant showing the parts that have to do with the growth of the plant. Observe the short root system compared with the network of roots of the four hills of growing corn illustrated on page eleven.

the soil conditions necessary for the manufacture, maintenance and proper distribution of that food to the plants as they need it.

Botanists tell us that every part of the plant has functions which it performs for its own development. The functioning of the various organs of the plant is naturally very different from that of the animal, nevertheless, these organs are just as important to the plant as the digestive and breathing organs are to the animal. The greatest of care is exercised in feeding the stock. The proper amount of food and water is given to the animals at the right time. In the summer the green pastures supply the great percentage of food for cows. In the winter they are given foods which produce milk and flesh. If horses are being used in the field they are fed the kind of food that keeps them strong and healthy. The same rule holds true of the entire animal family. No two types of animals ever receive the same kind of food nor even the same portion; that has to be given according to their kind. The same feeding law holds true of plants.

Plant life is different from animal life. The animal is either fed by human hands or goes about searching its own food. The plant is stationary. It, therefore, must subsist upon the food contained in the air and soil within reach of its organs.

All crop producing plants have roots, stems, leaves, and flowers, or the fruit. The farmer is concerned as to the quality and quantity of fruit produced. The quality and quantity of fruit are determined by the growth of the leaf and stem, and also the plant's ability to withstand the evil influences of wind, drouth and excessive rainfall.

The seed of any plant is supposed to contain enough nourishment for growth until the roots are large enough to drink in their nourishment from the surrounding soil, and the stem to break through the top of the ground to breathe in the required air.

The roots are the organs that search out into every particle and recess of the soil within reach for plant food, and carry it to the stem.

The most important part of the crop growing operation consists in bringing about a soil condition whereby the seed can germinate according to its natural inclination and the plant produce a root system necessary for vigorous growth and flowering.

The little kernels in the wheat illustration were sprouted to show how little and tender are the roots of germinating seeds.

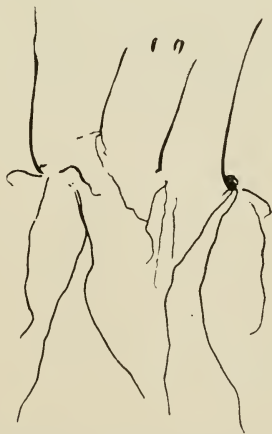

Four kernels of sprouted wheat. The two outside kernels would sustain the plant until the roots and stems could feed themselves. The two inside plants were weak seeds. The seeds are entirely consumed, and the young plants are not large enough to support themselves.

It is important that a seed bed be in a well pulverized, compact condition for the sprouting of seeds and growing of plants. The little kernels of wheat must sprout and grow, but before they can do it the plant food must be in the soil in available form for the little tender roots to feed upon. Observe the sprouts running up and the little roots going downward. One pinch of the root with the fingers would kill it, yet, it is supposed to grow and produce tenfold times. There is food enough within the kernel, if it is good seed, to nourish the growing plant for a short time, but after that it must reach out into the soil to find sustenance, and if that plant grows rapidly it must have the food within convenient reach just when it needs it. This is the great reason why the preparation of the seed bed is the most important part of the crop growing operation. It matters not how good the seed, if the soil is not in the right condition to make plant food available to nourish the starting plant, growth will be stunted. Pulverizing the ground when plowing is the first and most vital step to accomplish this end.

There is another reason why a compact seed bed is necessary. After the seed has sprouted, and the plant has acquired its growth, more food is necessary for the flowering of the grain. The roots are searching through the ground by means of their continued growth to find this food. The better pulverized the seed bed is, the more available food the roots find. They form a network of food seekers entirely occupying the ground from one plant to another.

The corn field illustration, in which the rain has washed away the earth from the roots, shows the interweaving of the root system of corn. Each of the little hair

roots drinks in its share of food for the plants. When we consider that plants are soup eaters, that is, all the food the roots absorb is taken in liquid form, the importance of having the best possible seed bed from top to bottom is obvious.



When the rain washed away the earth it generously left the corn roots in much the same position as they would be found if it were possible to look into the earth.

A study of this illustration shows how easy it is to break these roots by cultivation. Recognizing that roots are necessary for absorbing the food contained in the soil, the importance of protecting this root system and giving it every opportunity becomes apparent.

The stems are the conveyors of this food to the leaves and the flowers and also serve the important purpose of holding up the flowers and leaves from the ground to give them an opportunity to do their work.

The leaf has four principal functions to perform. It has to do with the starch making properties of the plant,

the assimilation, the excretion of water, and breathing. The functions of the leaves in these four processes involve a very complicated chemical process which is not very thoroughly understood and does not need to be from a practical standpoint.

The only thing necessary to know is that a plant, to flower and produce the proper grain, must have an abundance of moisture in order that the sunlight and air may supply the proper gases and heat necessary to bring about these chemical changes. The task of the farmer is to see that air, water and the proper plant food elements are properly proportioned in the soil. He need not worry about the part that surface air plays in the growing of the plants because it is beyond his control. Nature always supplies it abundantly on and above the earth's surface. To be of the utmost value air must be permitted to permeate every particle of the seed bed.

The tiller of the soil must see that the proper amount of plant food is supplied during the plant's life so that the entire plant can perform its functions. He must not forget also that a plant, even as any animal, can gorge itself so that one part of it will grow to the detriment of another.

The plant may be considered in part as its own food manufacturing establishment; that is, certain of the food elements coming from the soil are mingled with the gases which come through the leaves in such a way as to form the starchy substances of the plants. It is vitally necessary, therefore, that both the soil and air supply the proper elements for these processes to take place in the plant.

The amount of plant food contained in water is very small, hence, the plant must consume an immense

amount of water to derive the sustenance necessary. A grass plant has been found to give off its own weight in water every twenty-four hours in hot, dry summer weather. This would make about $6\frac{1}{2}$ tons of water per acre for every twenty-four hours in ordinary grain fields. This proves that moisture is one of the most essential items for producing plant growth and must be properly provided.

Botanists maintain that 95 to 97 per cent. of all the materials from which Nature builds the tissues of her plants are taken from the air. It is important, then, that we know by what process the materials from the air are transformed into plant food, particularly that part of the process which Nature depends upon tillage and the soil to perform.

Nature furnishes the moisture, air, light and soil. She expects us to till the soil in order that she may use the moisture, air, light and soil to the best advantage in transforming materials into plant food for growing crops. She rewards bountifully those who work with her, and she recompenses poorly those who do not.

Working with Nature means a knowledge of the effect of moisture, air, light and heat upon the soil and applying that knowledge in a practical manner.

CHAPTER II

Influence of Water

WATER is the greatest single factor in plant growth. It seldom rains at just exactly the right time for its use. The task is to keep this moisture where it can be utilized by the growing plants just as rapidly as they need it. Before this can be done successfully one must have a knowledge of the characteristics of the different types of soils, their capacity for holding moisture and the rapidity with which it percolates and evaporates, also the things that are necessary to permit moisture to sink into the ground and keep it from escaping.

Water is the solvent of mineral elements in the soil which nourish the plant, and since plants can absorb mineral salts only in solution, water is absolutely necessary to enable the plant to take nourishment from the soil.

Water is the means whereby plant food elements are transformed into plant food because without it there can be no chemical action or reaction to transform the elements into plant food. Water also holds in solution food for the plant, carries it from the hair roots to the stem, and from the stem to the places where growth is taking place, transports plant food from one place to another in the soil, and is a temperature regulator for the soil.

From 75% to 90% of the fresh substance in crops is water, thus water in itself is plant food and essential to

plant life. The greater part of this per cent. enters the plants through the roots.

The 75% to 90% of water making the fresh substance of plants is water in plant composition, and can only be taken from the plants by excessive heat. However, this water in composition is dependent upon the amount of moisture contained in the soil and the humidity of the atmosphere because the growth of the plant is retarded or advanced as the amount of moisture in the soil is available. This moisture in turn is controlled more by the soil than the atmospheric temperature. Hence, it is necessary to have moisture in the ground in the right proportion for regulating the heat to retard the process of evaporation as well as to promote the development of plant food.

It is impossible to definitely define what amount of moisture is required for the growth of a plant because a great many conditions enter. A crop may require 300 tons of water for growth to maturity. It may be necessary for the soil to furnish 350 tons on account of varying conditions. Some the farmer can control, others he cannot. Water that must be supplied for the growing crops includes that which is constantly evaporating from the ground and also that which the leaf and stem of the plant are giving off.

The amount of plant food in water is very small; that is, the solution is in a very diluted form. For this reason a plant consumes many times its weight in water to get the necessary food.

The principal factor which determines the water requirements of a plant is the humidity of the atmosphere. In climates where the atmosphere is moist the water requirements for the plants are much less than

those in dry climates. The reason for this is the amount of evaporation from the leaves and stems. The more humid the atmosphere the less moisture it takes from the plants, the dryer the atmosphere the more moisture it draws from the plants. If the atmosphere were thoroughly saturated at all times the water requirements for the plants would be very small because of the light transpiration of water from the soil.

Another peculiar fact in connection with the water required is shade. Shade increases the amount of water required for plant growth. It retards the process by which the plant constructs its tissues because the rays of sunlight necessary for this process are diminished.

Soil fertility has a great deal to do with the amount of moisture required to grow a crop. A poor soil requires more water than a rich soil for the simple reason that the more fertility there is in the soil the stronger the water holding content. A soil may be fertile in all the elements but one. The lack of this one causes the soil to require more moisture because growth is retarded when a plant fails to get any one of the elements necessary. The plant keeps on using and giving off water exactly the same as though all the elements were in the soil.

The great problem is to catch and save as much of the rainfall as possible. The ground below the seed bed must act as a reservoir to hold enough water for it to come upward by capillary attraction to the root bed and not escape into the air.

Capillary water is that which adheres or clings to the surface of the soil grains and to the roots of plants in films thick enough to allow surface tension to move it

from place to place. It is Nature's means of keeping a constant supply where plants can use it. Capillary water is the chief source from which plants derive their supply. So important is capillary water that crops grown on moderately fertile plots where water was supplied as fast as plants could utilize it, produced more than four times as much as the same crop grown in an adjacent field under ordinary conditions. The reason for this is simply that during all the growing period rains do not come at the right times. This naturally prevents the plant food from becoming available every day as the growing plants demand. It is like stuffing a boy one day and expecting him not to get hungry for a week. Feed the boy what he needs each day, and he grows into a strong man. So it is with plants.



A

B

C

D

The picture (A) of the tube filled with fine soil particles with the clods in the center illustrates very common conditions in plowed ground. The clods in the center prevent capillarity between the upper and lower portion of finely pulverized soil. Consequently, the moisture

from below cannot reach the pulverized soil above the clods any faster than the rays of light and heat evaporate from above. This is plainly noticeable in the views showing the water at different heights in the tubes.

In illustration B observe that the water has traveled upward in the tube to a level much higher than the water in the pan, showing the force of capillary action. Also observe the firmly compact condition of the earth as far as the water has traveled.

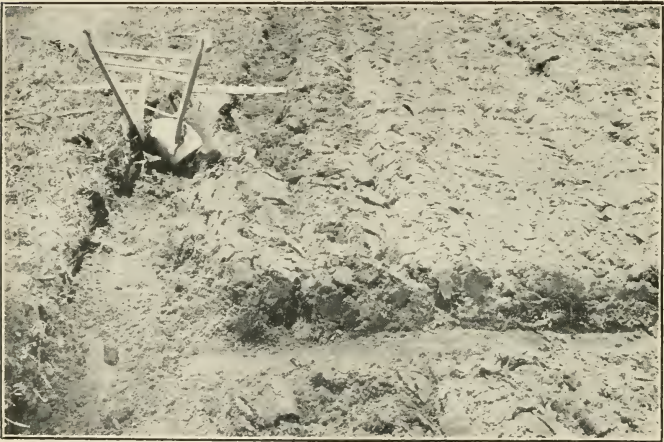

This is the way plowing is generally done. The large air spaces at the bottom of the first furrow slice and the smaller one in the bottom of the third are often found in fields that have been harrowed and are supposed to be ready for planting. These air spaces interfere with the upward trend of capillarity just exactly as is shown in the tubes on page seventeen.

The sectional view of plowed ground in the illustration above shows very much the same condition as shown in the tube.

In illustration C the water has reached the bottom of the cloddy portion. The uneven edge shows that where the soil particles are compact the water climbs upward, thus illustrating an important characteristic of capillarity. Too many air spaces in the cloddy ground break up the capillarity so that water will not climb as rapidly or as effectively and abundantly as it does in soil finely compacted. Two hours were required for the water to rise from the bottom of the tube to the cloddy portion.

Illustration D is the same tube photographed 22 hours later. Observe that the soil is thoroughly permeated with water up to the cloddy portion, that the moisture in the cloddy part and the pulverized part above the clods is very slight, and that on top no moisture is to be discerned. This shows that moisture does not rise to the surface of the ground any faster than it is evaporated. If this tube contained a plant above the cloddy part it would be plainly evident that the amount of moisture the roots could secure would not be enough to promote the healthy growth of the plant. Therefore, it is very important that this cloddy condition does not exist at the bottom of the seed bed as much on account of moisture as heat and air.

Film water displays itself only upon the surface of the soil grain. That is why it is called film water. It forms a film around the grain. Anyone can easily satisfy himself as to the truth of this, by taking a marble and immersing it in a glass of water, then withdrawing it. All the water required to form the film will cling to the marble and the rest will drop off. Suppose that marble is one inch in diameter. It will fill a cube one inch square—that is, six points on the surface of the

marble will touch six points of the cube and all the rest of the space between the cube and the surface of the marble is air space. The area of the surface of the marble is found by multiplying the diameter squared by 3.1416, making 3.1416 square inches of film surface for the water. This is the amount of the film surface displayed.

A cube one inch square will hold 1,000 marbles one-tenth of an inch in diameter. The square inch of surface of each marble one-tenth of an inch in diameter is one hundredth of what it is on the large marble, or .031416 of an inch. This multiplied by 1,000, the number of marbles of this diameter required to fill the cube, makes 31.416 square inches of film surface, in contrast with the 3.1416 displayed in the one marble. Thus, if you take the 1,000 marbles in the cube immersing them in water, and withdrawing them as you would the large marble, you would have 31.4+ square inches of surface holding water, against 3.1+ square inches on the large marble. This means that the air spaces have been diminished in size and the water holding content of the soil increased, proving that the finer the soil is broken up, the greater water-holding capacity it has, consequently, the breaking of the soil into fine particles is necessary to improve it for water holding content. For this reason the ground should be well pulverized when plowing.

It is further evident, from the marble illustration, that the size of the soil particles has everything to do with the water holding content. As an illustration of the capacities of different soils, for capillary attraction and for holding water, samples of clay, clay loam, loam, sandy loam, and loamy sand were placed in the tubes under the names, small clods being placed on top of the

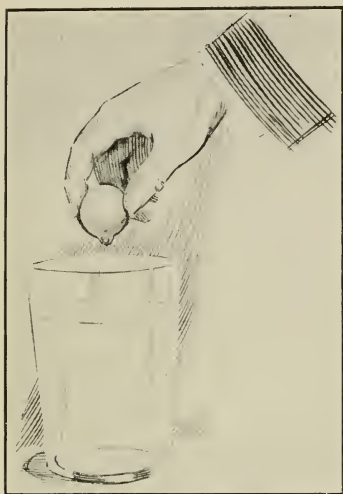

Dipping a marble into a glass of water as shown in this illustration will convince anyone that surplus water will not cling to the marble when it is removed. Enough water should be supplied in the soil so that a film of water surrounds the soil grains.

The six points of contact leave large air spaces which retard capillary attraction and permit an excessive amount of air and heat to evaporate what little moisture may be in cloddy ground.

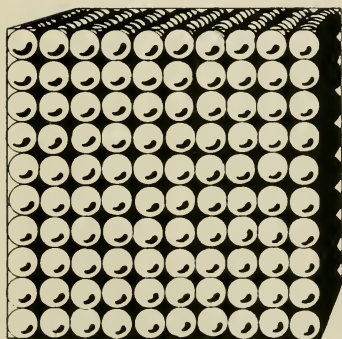
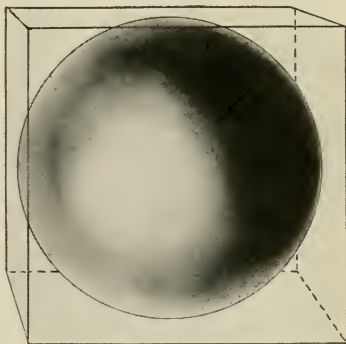

The thousand marbles make six thousand points of contact thus showing how much easier it is for moisture to travel upward by capillarity, the increased surface for holding film water and diminished air spaces.

finely pulverized soil. Clay has the smallest soil particles; clay loam the next larger, loam larger than clay loam; sandy loam larger than loam; and loamy sand larger than sandy loam. This pan was filled with water, giving it an opportunity to rise in the tubes by capillarity.

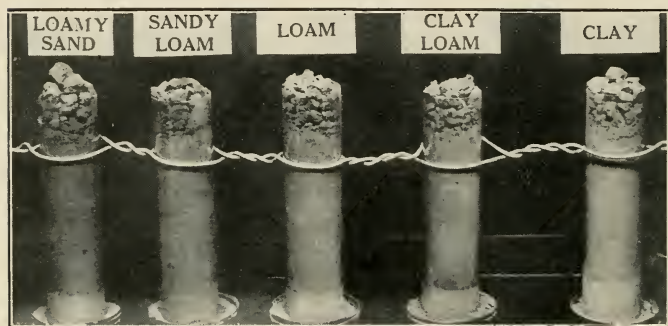

The five samples of soil in these tubes were taken from the same farm. They are shown on pages 39, 41, 43, 45 and 47. At the top of each tube is a granular mulch. The particles of earth are much coarser than those of the finely compacted earth below. These tubes are eight inches high and two inches in diameter. The earth was packed in each tube to bring about an ideal condition for capillary attraction to act. The soil was also placed in an ideal condition for germination of the seed and the growth of the plant. The surface was not. Do not fail to observe the effect of this granular mulch in the illustration on page twenty-four.

The illustration at the top of page twenty-three shows the water is almost halfway to the top of the finely pulverized earth in the tube of the loamy sand; has a good start in the sandy loam; is just beginning in the loam; is hardly perceptible in the clay loam, and not at all in the clay. Thus, we observe that up to this period capillary attraction is faster in the sandy soils than the clay, and that the loam is about midway between.

The second illustration on page twenty-three shows the water in the tube filled with clay has just started

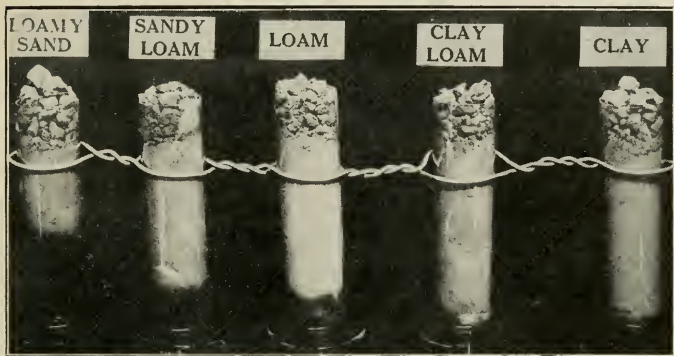

while that in the loamy sand tube has almost reached the top. The clay loam, loam, and sandy loam are still drawing water in about the same proportion as shown in the previous illustration.

The illustration on page twenty-four shows the water in the tube filled with loamy sand has reached the cloddy portion, while that in the clay tube has gone about one-fifth of the way to the top of the tube. The water in the other three is still climbing in the same proportion, thus showing conclusively that the finer the soil particles are, the slower the water rises.

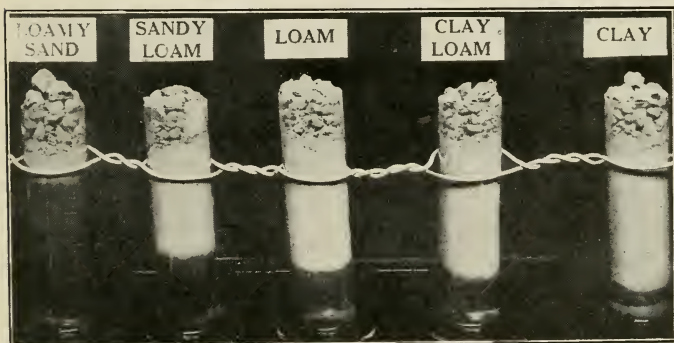

Another feature that must be taken into serious consideration is that soils, in which water rises rapidly, dry out equally fast, thus the sandy soils dry out much quicker than the clay soils, all of which goes to show that the finer the soil particles are, the stronger the attraction to hold the water.

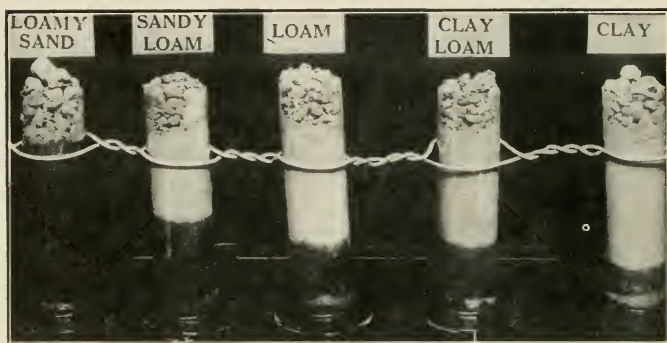

Compare the water in the loamy sand and clay tubes illustrated on page twenty-three with those illustrated above. The granular mulch on top the tube of loamy sand stopped the upward trend of moisture as the distance the water in the clay tube has travelled upward shows. The moisture in the loamy sand tube has climbed from a point just below the wire to the granular mulch while the water in the clay tube travelled twice as far as it had, thus showing that the granular mulch stopped the upward trend of moisture. This illustration serves to show the importance of keeping the soil particles on the surface in an entirely different arrangement from those below in order that capillary attraction may be permitted to act up to this point and then stopped, thus keeping the moisture in the ground.

Observe further the soil at the top of the tube filled with loamy sand; that the water has not penetrated the clods to any appreciable extent. Bearing in mind the illustration of the tube with the clods in the center, it will be observed that a granular surface on top is better to prevent moisture from escaping into the air than the finely pulverized soil. The reason for this is simply that capillarity has been broken up between the com-

pact sub-surface and the granulated top. For this reason it is better to have the lower portion of the soil compact and the layer on the surface coarse and granular than to have it all finely pulverized.

When a farmer desires to plant a field infested with cutworms, grubworms, wireworms, or some other pest which can be eradicated by plowing, he wants to know whether it is best to plow for the express purpose of killing the insects, for the conservation of moisture, or at a time of the year when plowing can be easier done. He must decide which is the most important and plow accordingly. The number of times that one would run into difficulty with moisture when plowing to kill insect pests would be very few because the ideal time to plow to kill insect pests is during their larva state, which for the most part is in the fall of the year.

If one plans on plowing sod with the expectation of growing a crop it is better to fall plow for the moisture conservation process and also for the killing of insect pests. The small profit that may be made in pasturing such fields is much less than the total accruing from plowing in the fall previous to planting. This has been demonstrated sufficiently to be stated as a fundamental fact.

If one studies carefully the conditions mentioned it is evident that the damage done during dry periods can be minimized by having the soil kept in the proper physical condition by the right kind of tillage to save moisture for use at this time.

From the foregoing it is obvious that soil moisture very often determines whether a yield will be large or small. The same needs for moisture are present, north, east, south and west, and the same laws for con-

servicing must be applied. The degree to which this conservation must be practiced is determined solely by the amount of moisture contained in the soil. In the more humid districts it may be only necessary to adopt a system for conserving the rains of summer and fall; whereas, in the dryer territories it may be necessary to practice a system of summer fallowing for an entire year before enough moisture can be saved to insure a crop. The big thing to remember is that moisture must be present when the plants need it.

Those farms underlaid with clay soils are easier to till for conserving moisture for future use than those which have an endless depth of sand or gravel. If the sub-soil is of such a nature that it will not hold moisture within the distance which capillary attraction operates, the problems are extremely difficult and almost beyond control unless the soil is kept chock full of humus at a depth deep enough to prevent surface heat from evaporating the moisture.

CHAPTER III

Importance of Air in the Soil

WATER, heat and oxygen are necessary for the germination of seeds. Oxygen must come from the air, hence it is necessary, in the preparation of the seed bed, to leave the ground in condition for the circulation of air.

In view of the fact that seeds must germinate before the plants can grow, the nearer the oxygen and moisture are in the right proportion in the ground, the more rapid will be the germination and growth of the plant.

In the development of plant food for growing plants the elements that go to make nitrates are largely confined to the first few feet of surface soil. If the soil is loose enough to allow access of air, nitrification is more rapid, hence plant growth is more rapid. It obviously follows then that plowing and cultivating are necessary for the development of plant food.

Air is also necessary to keep the ground in condition for the retention of plant food after it has reached the nitrate form. The roots of plants need oxygen in the process of growing. Energy is required. The roots penetrating through the ground absorb the oxygen and thus acquire the needed energy for the work of pushing the soil particles to one side.

Nitrogen, in the form of nitric acid, is the most important of all plant food elements. Oxygen gives life or activity to prevent destruction of nitrates after they have once been made. Wet soils, rich in organic

matter, often give off more free nitrogen than is used in forming the nitrates in them. Thus they become depleted on account of too much water and not enough oxygen. Too much oxygen in the soil burns up the fertility and has a tendency to form clods.

Seeds will not germinate in ground from which oxygen has been completely excluded; neither will growth take place. Water, completely filling pore spaces, excludes oxygen. This is another way of saying that plants drown. The human being drowns because oxygen is excluded from the lungs; so do plants. Compact earth prevents

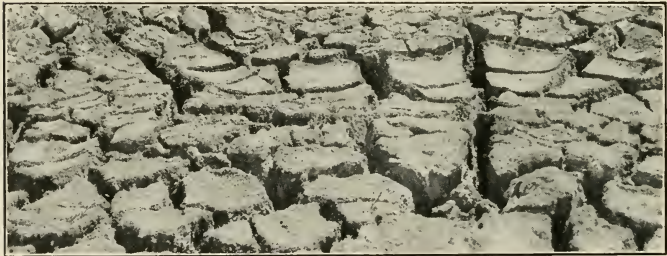

This illustration shows a soil that had been covered with water for a long time. The excessive air spaces caused by these cracks are due to the shrinking of the soil particles after the swelling caused by the water. It is easy to see that the cracks penetrate deeply thus causing the air and heat of the sun to evaporate the moisture from a great depth.

circulation of air and creates a condition fatal to growth, even if the ground contains sufficient moisture. Some authorities claim poisonous gases are formed by this condition.

While the evil effects of excluding air from the soil are many, it is equally true that too much air is harmful. Air is just as essential in the forming of nitrates as

moisture. Consequently, if all the air were removed from the ground there would be no forming of nitrates, and plant food could not be produced. Too much air makes cracks and fissures in the soil, drawing out moisture, oftentimes to such a depth as not only to stunt the crop, but kill it. Too much air in the soil in the spring can easily cause the loss of enough moisture to grow a crop.

It is a well known fact that the atmospheric pressure on the earth's surface is 14.7 pounds per square inch at sea level. The amount of nitrogen in these 14.7 pounds of pressure is 77%. It is perfectly logical, if the ground is broken up and thoroughly pulverized when plowing, that this pressure of 14.7 pounds per square inch will force the air into the soil taking with it 77% of free nitrogen. It is the air circulating around every particle of soil in conjunction with capillary moisture that liberates plant food for the growing plants.



This field is similar to that shown on page twenty-eight but in a much less aggravated form. However, if left to itself for any length of time it is easily possible to see how the cracks would widen and deepen.

Scientists tell us that wheat, oats, barley, rye, etc., take up the nitrogen, which they use from the roots, and then only in nitrates in dissolved form. Hence, nitrogen must be available in the ground.

The more nitrates there are in the ground per acre the greater chance the farmer has of growing increased crops. He may have his phosphorous, potassium, calcium and water, but unless he has the nitrogen which he can get from the free air, he can never grow the proper kind of crop.

Since the need for air in the soil is highly important it behooves the plowman to be very careful to see that the ground is thoroughly pulverized and that all large air spaces are eliminated and the after preparation of the seed bed made so as to keep the air and moisture mixed in the ground in as nearly the perfect proportion as possible. Enough has been said to show that the perfect condition in all soils is when the soil has natural air spaces between the soil particles. This is one reason why Nature makes soil particles with irregular surfaces. The best way for aerating the ground is to thoroughly pulverize when plowing. To be sure of this requires a study of the shapes and sizes of plow bottoms, because different soils require different shapes, sizes and curvatures of bottoms to bring about the desired result. Also the time of the year that the plowing is done with relation to the time elapsing between the plowing and planting has a great deal to do with the success of this practice.

In the chapter on the temperature of the soil attention is called to the difference in the temperature required for the most propitious development of plant food and the planting of wheat to resist the winter's freezing.



Observe how deeply fissures will penetrate the ground when conditions are ripe. This condition can only be prevented by a mulch of earth on the surface to keep moisture travelling upward from the ground water level to the mulch, and the rays of heat and light from penetrating.

Summing up the importance of air in the soil, temperature and plant food development, and the killing of insect pests we find that early summer plowing, with complete burying of stubble and trash on the bottom of the furrow, is the best method for killing the Hessian fly, and aerating the soil at a time when nitrates develop best. At this time there is the least amount of rainfall to wash away plant food and the soil is in the best possible condition for the percolating and saving of what rain does fall so that later in the fall when the time comes for planting wheat it is at a cooler temperature with plant food enough developed for giving the wheat a remarkably good start, thus lessening its chances of winter killing.

CHAPTER IV

Soil Temperature

FOR centuries farmers have observed that some soils are seemingly better adapted than others to grow certain kinds of crops. These observations naturally have led to what is called "wheat soil," "barley soil," "rye soil," etc. While these observations on the face of them would lead one to think that some soils are more adapted than others for crop growing, there is a great deal of doubt as to their real merit because in the light of present-day experiments crops have been grown in pure sand which had been supplied with the plant food elements and the amount of moisture necessary to grow plants.

Climatic conditions have much to do with crop growing, consequently, when one begins to study what crops that soil is to produce, he must take into consideration the climatic conditions as well as the soil. Naturally then, if a farmer can supply a soil with conditions equivalent to climate, he can, to the extent of that ability, grow plants in any soil.

The wheat and oat plants offer an interesting illustration of this fact. Assuming that the proper fertility is in the soil, whether it is sand or clay, climatic conditions, that is, temperature and water, must determine the growth. Up to the time of ear shooting wheat needs wet, but not too warm weather; at flowering

time, dry, warm weather; during the ripening period, medium moist weather, and dry weather for harvest. The oat does best in moist and relatively cool weather.

It is not to be supposed that it is possible for a man to control the temperature of the soil to the degree that he can bring about climatic conditions for growing a crop, but by the proper conservation of moisture and cultivation of the soil it can be made warm in the spring



Ground in this condition becomes too hot in the summer for the successful development of nitrates for growing corn. This soil, a silt loam, requires very careful handling to prevent its powdering.

when it otherwise would be cool, and cool in the summer when it otherwise would be hot. To this extent the temperature of the ground can be controlled. This aids very materially in the growing of crops. The means for bringing this about center around the amount of moisture in the ground and the rapidity with which it

is permitted to evaporate. The evaporation of moisture is determined by the kind of soil, its compactness, the amount of surface exposed to the rays of light, and the wind. The greatest difference in temperature between the different types of soil takes place in the early spring thawing and the period immediately following. This is of utmost importance to farmers especially at planting time because a small amount of difference in the temperature of the ground means speeding up or retarding the rate of germination of the seed and the growth of the plants. Other things being equal, it logically follows that the sandy types of soil can be planted earlier in the year than the clay types.

When a soil is cultivated a larger area of its surface is exposed, thus the amount of evaporation is very much greater. The result of greater evaporation is that the temperature of the cultivated soil rises much higher and faster than that of the uncultivated, and permits earlier planting. This is one of the strongest arguments for fall plowing and leaving the ground rough. In the spring of the year the additional exposed surface dries out much more rapidly and thus permits earlier seeding. The most interesting part of this process is that as soon as a dry mulch of this earth is formed on the plowed soil the loss of water by evaporation is reduced very much, while the loss on the unplowed soil is still greater. In the summer this reduces the temperature of the mulched ground, while that of the unplowed ground is considerably raised.

A further observation is that the heat which is not utilized in the evaporation of water is being rapidly conducted downward in the unplowed ground, thus causing it to dry out at great depth. On the cultivated

or mulched land only a small part of the heat is conducted downward. The other is radiated back to the atmosphere by the dry ground on top. This is because the mulch breaks up capillary attraction with the moist soil below, acting somewhat as a blanket to hold the moisture down and keep the heat out. When this mulch becomes completely dry, as it often does, during the hot summer, it radiates back large amounts of excessive heat to the atmosphere, thus, we find the effect of this mulch upon the soil as follows:

It prevents the soil from reaching a high temperature during the day and a low temperature during the night; it greatly warms the soil in the spring; it tends to conserve moisture in the lower strata and consequently reduces the rate of cooling in the summer. The importance of this is very manifest when one considers the temperature necessary for the development of nitric acid.

Soluble nitrates do not form at a temperature below 41° Fahrenheit. The most favorable temperature is between 60° and 85° Fahrenheit. They form very slowly at 115° and at 130° will not form. It has been determined that wheat germinating at a temperature of 40° Fahrenheit is more resistant to cold than wheat which germinates at 64°. Obviously, the temperature for the greatest formation of nitrates, which are necessary for the development of plant food, is too high for the successful growing of wheat to withstand the winter's freezing. This makes it necessary, if the most favorable condition for wheat is to be brought about, to plow the ground and keep the seed bed at a temperature of from 60° to 85° Fahrenheit in order that plant food may be developed for the growing of plants which must be grown at a cooler temperature.



This ground plowed in the fall was very dry and hard. The winter's freezing broke up the clods so that the harrow easily pulverized them.

CHAPTER V

Why Soils Must Be Handled Differently

THE soil is the farmer's working capital. It is necessary that this capital be used in the wisest possible manner to earn the profit which justly belongs to him. Carelessly handling the soil results in a loss just exactly in the same manner as the mishandling of working capital results in loss to a manufacturer. The broad business principle underlying manufacturing and farming is identical but the tools and working capital of the two are widely separate and hence must be handled in a manner peculiar to each before either can achieve success.

Soil is a combination of disintegrated rocks, dead vegetation and many living forms, such as bacteria and fungi. Broadly speaking, soil may be regarded as matter in which a planted seed can grow to maturity. The difference between soil and earth or ground, from a practical standpoint is so slight that the terms are almost synonymous.

When comparing the mode of life of the plant with that of a human being, the soil around the plant may be regarded as the dining room in which the plant eats, the kitchen in which its food is prepared, the storehouse where the food elements are kept in reserve, a reservoir for the water and a ventilating system. When one reflects upon the numerous results this working capital is supposed to produce, the more concerned one becomes as to how it should be treated.

It is plainly evident that all these conditions are necessary to bring about plant growth. When we understand that plant growth, in the form of either legitimate crops or weeds, consumes plant food, or fertility and the water which is contained in the soil, we see why it is necessary to replenish the fertility and change the condition in this ground before new development of plant food will take place. Plowing is the only means known to human endeavor that will successfully start this process. It is highly important then, that one should understand the peculiarity of the soil he desires to plow before he can do this efficiently.

There is scarcely a farm, regardless of how small it may be, that is made up of less than two distinct soil compositions. The fact that most farms are made up of several soils, some of them radically different, means the necessity for a thorough understanding of the types because they must be handled in an entirely different manner to bring about good results.

There are many soil combinations but the most common are clay, loam, clay loam, sandy loam, loamy sand, sand and muck. We will go into some detail in the clay, loam and sandy soils because they are by far the most common and will serve as illustrations of the fact that each soil must be tilled according to its kind. Indeed, there are many types of soils that are never mentioned in books which have bountifully repaid the tillage of farmers who studied their characteristics, and by long, bitter experience learned how to handle them for crop growing.

Clay is the hardest soil to till on account of the peculiar effect water and air have upon it. It holds

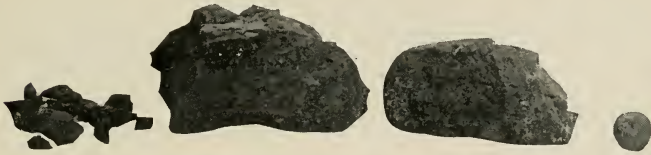

This sample of clay and the soils illustrated on pages 41, 43, 45 and 47 were taken from the same farm, comprising 240 acres. These entirely different soils coming from one farm offer the strongest evidence that every farmer should thoroughly understand soil composition. A careful examination will reveal the similarity of the specimens to the land being plowed.

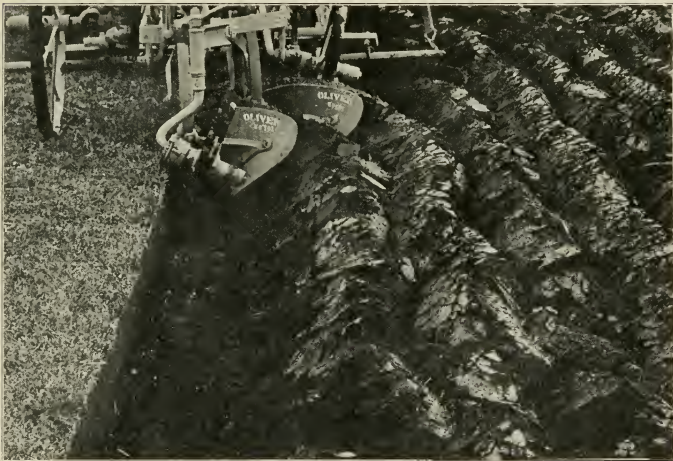

The same peculiarities of the clay soil in this plowed ground obtain in the specimen above. Finely pulverized earth is not to be seen.

moisture longer than any other kind of soil with the possible exception of peat; bakes hardest; forms clods easiest and cracks into deeper fissures, per-

mitting great quantities of moisture to escape. Clay never works up into a loose, mellow seed bed, but rather one of clods or fine dust which blows easily. Cultivated when wet, clay forms into clods of different sizes, from that of a walnut to as large as a person's head, depending upon the kind and amount of cultivation. The grain is fine and has a peculiarity not discernible in any other type of soil. Moist clay is soft and sticky. It can be kneaded and formed into various shapes and bodies. Small boys, unable to buy marbles, use clay very successfully for making them. A small piece of clay can be easily smoothed and polished by the fingernail. While polishing a greasy or soapy feeling will be noted. Moist clay, when rubbed between the thumb and finger, has a slippery feeling. Persons walking on a sloping bank of wet clay are apt to have their feet slide out from under them very suddenly. Clay in a powdered condition when moistened, has a peculiar odor unlike anything else. Clay in color may be red, yellow, blue, white, black or chocolate.

For the most part clay soils when plowed too dry, form large clods which are decidedly hard to break into pulverized condition. If such soil lacks humus in sufficient quantities to keep it friable, it nearly always forms a powdered surface. Among these peculiarities of clay the fact that it holds moisture longest, bakes hardest, and forms clods easiest should be a warning that the greatest of care must be exercised in plowing dry clay soils, if there is a possibility of rainy weather coming between the time of plowing and planting, because the dry soil in this powdered condition will run into a sticky, plastic mass which will later dry hard and crack



In this specimen of clay loam soil the peculiarities of clay predominate but the smaller clods to the right show that this soil can be pulverized more effectively than the clay soil.



The finer pulverized earth distinguishes this clay loam from the clay soil, but many of the distinguishing characteristics of clay can be readily seen.

so that it cannot be broken up successfully by any kind of cultivation. This peculiarity of clay has led many farmers to ridicule so called scientific methods of farm-

ing because they were told that it was impossible to disk or harrow too much. A winter's freezing is the only successful treatment for rectifying the evil done by plowing a dry, clay soil lacking in humus and within the limit of abundant rainfall and planting the crop. Farmers who live in climates where there is no opportunity for freezing can ponder with a great deal of profit upon this problem.

It is common knowledge that a soil plowed wet will dry out more rapidly than unplowed soil. Plowing wet clay has the same effect that plowing a wet sand soil has as far as the drying out is concerned but with entirely different results. Clay, being of a plastic nature and sticking close together, is puddled by wet plowing. It is turned over in a closely compacted manner so that the top dries out first leaving a slower drying process for the bottom of the furrow. This naturally means that avenues of escape must be formed for the moisture below. These avenues will appear at the place of least resistance in the soil. These places are caused by the action of the mouldboard in turning over the soil. The result is a cloddy formation at the bottom of the seed bed which locks up the soil fertility in the clods, interferes with the upward trend of capillarity and makes absolutely impossible a final preparation of the seed bed. The plow mouldboard working in wet clay performs exactly the same operation as a brick making machine does in molding the clay into bricks, hence in the handling of clay soils the plowing must be done at a season of the year when clods will not be formed.

When one considers that clay soil holds moisture longer than any other type of soil it is obvious that clay



This specimen of loamy soil does not reveal either of the characteristics of the clay or the sand but does show a combination of the two in such form as to make this soil readily tillable.



Observe in this plowing the absence of large clods and the same granular appearance that is plainly noticeable in the illustration above.

land tilled in such a way as to conserve moisture will stand drouth much better than coarser grained soils.

Fall plowing of clay soils in climates where the ground freezes deep enough to separate the soil particles is becoming more generally practiced. The reason is that

whether or not the ground is in ideal condition for plowing in the fall it can be turned over covering up the vegetation so that it will rot during the winter, and in the spring when the ground thaws the soil will be in condition for the successful making of a seed bed providing it is not harrowed when wet. Care must be exercised however, in fall plowing of clay soils, to leave the ground rough because if it is left in a smooth condition the surface soil will run together by the action of the water in the spring, bake, and form a crust that will be difficult to handle. The principle underlying all this is simply the importance of permitting the surface moisture to escape and holding that which is below in the ground. If this idea is thoroughly understood the handling of clay soils need not necessarily be difficult, but one must have enough power on his farm and the right kind of plow to do this work when moisture conditions are right. The unfortunate part of putting off plowing clay soils until spring is that the farmer is taking one of three chances. The soil may be ideal for plowing, it may be too dry or it may be too wet. When the soil is ideal everything is propitious, no damage done. When the ground is too dry it is impossible to make an ideal seed bed on account of one of the two extremes—the ground plows up into either hard clods or fine dust. When the ground is too wet the condition that has been mentioned previously in reference to puddling of clay soils obtains. It is doubtful whether one would take such chances if he thoroughly understood the damage he is doing by postponing the plowing. Of course, the argument that farmers do not have time to fall plow every year carries a great deal of weight because it is absolutely true. But why is it not possible to plan a crop routine in which this principle is taken into con-

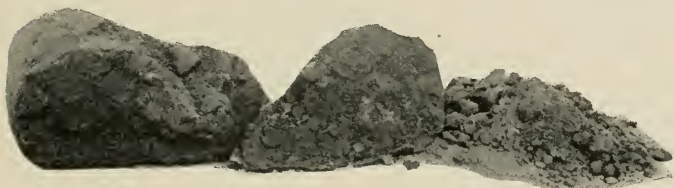

In this specimen of sandy loam traces of the clay are noticeable but the sand predominates. Obviously the selection of a plow for turning this type of soil must be different from that used in plowing clay soils.



Observe the characteristics of the sandy loam soil in this picture, and also the different manner in which the furrows are laid from that shown in the plowing of clay on page thirty-nine.

sideration? A great many farmers are now following such plans and the results show the wisdom of this practice.

Loamy soils are made up of sand and clay in such composition that the identity of each is lost. When pressed

between the thumb and finger a granular, raw feeling is distinctly noticeable. It has neither the rough, gritty feeling of the sand nor the smooth, slippery feeling of the clay. A ball of dry loam is porous while a ball of dry clay is compact. Loam crumbles readily, making it easy to plow and cultivate. It dries out faster than clay, and slower than sandy soils. It does not form hard, unbreakable clods like clay, nor does it crumble so easily as sand. It forms into a mellow, compact seed bed, and gives the farmer more return for poor cultivation than any other soil. These characteristics of loam undoubtedly give rise to the statement that anyone can throw seed into the ground and it will grow, meaning, of course, that anyone can farm.

The expression, clay loam, means that the clay predominates in the composition, and sandy loam means that the sand predominates in the composition, therefore, the handling of a loamy soil must be more inclined towards the soil which predominates. That is, a clay loam soil should be handled more like a clay soil and a sandy loam should be treated more like sandy soil. Clay loam is much easier to plow and cultivate than clay because the sand in the loam breaks up the compact relationship between the clay particles. It has much the same texture as clay soil. It can be worked to better advantage than clay soil when wet, although not successfully. It forms a more compact and mellow seed bed. The cloddy formation is less predominant than in clay. It has the clay characteristics of cracking and drying out and must be handled in such a way as to prevent this.

Sandy loam can be told very readily by its grain. Sometimes the particles are large enough to be easily

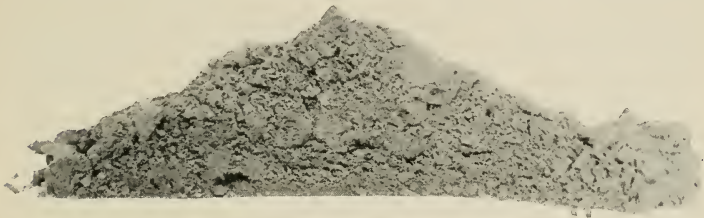

This specimen of sandy soil shows how quickly it dries out. The blurred portion to the right was caused by the soil drying and falling at the moment the photographer was exposing the negative.



In this illustration of plowing sandy soil the furrows are regular in shape from one end to the other. The finely pulverized ground is just as noticeable in the plowed field as in the specimen shown above.

seen by the naked eye. They can always be distinguished by the use of a magnifying glass. A sandy, gritty feeling is noticeable when rubbing the soil between the thumb and finger. This is a never-failing way of recognizing a sandy soil of any character. The sandy loam, as the name signifies, is a mixture of sand and clay, with the sand in larger quantity than the clay. This makes it a less porous soil than the loamy sand, but more porous than clay. It works up easily, does not form hard, unbreakable clods, and is particularly well adapted to the growth of tuber crops. It does not require so much effort to plow or work up into a seed bed as clay loam, but requires more effort than the loamy sand.

Loamy sand is a combination of sand and loam in different degrees than sandy loam. Sandy loam contains more loam than sand, and loamy sand more sand than loam. The easiest and best way to distinguish between these two types of soil is to make them into balls. The sandy loam will hold its shape, while the loamy sand will not. Loamy sand dries out the quickest of any type of soil. It is the easiest to plow, it never forms clods, is coarse grained, and is easily distinguished by the gritty feeling experienced by rubbing it between the thumb and forefinger. It is a soil that has to be handled with the greatest of care or it will produce nothing. It readily blows on account of the rapidity with which it dries out.

The grains of sand are much coarser than particles of clay. Obviously, there will be larger air spaces. These air spaces permit moisture to percolate downward rapidly. Sand, in a loose condition is thus easily packed by a heavy rain. The water percolating downward naturally

carries with it the grains of sand until they strike other grains and cannot be carried farther. Thus, the process continues until the final arrangement of all the soil grains is such that there is no further opportunity for the force of gravity to operate. This principle must be carried constantly in mind when farming sandy soils because the water compacting the soil in this manner on its downward trend makes the finest capillary connection possible between the top of the ground and the lower surface. Thus, when the weather warms to such an extent that water vaporizes on the surface, moisture is drawn from below by capillary attraction with great rapidity. The only way that this can be stopped is by changing the relationship of the soil particles on the surface. This can be brought about by the use of any implement that will stir the soil. Whatever implement is used, the relationship of the soil particles must be entirely changed so that the moisture from below cannot escape into the air by capillary attraction.

With this understanding it naturally follows that sandy soils require more frequent liming, fertilizing and a greater amount of humus than the clay soils, also more frequent cultivating on the surface if one expects to get the most out of them. A question often arises as to the advisability of plowing sandy soils in the fall for spring planting. These water peculiarities of sandy soils make a great difference between the time of plowing and the planting season. In the chapter on the temperature of the soil, reasons are given as to why sandy soil becomes warmer earlier in the spring than clay soil. This earlier warming of sandy soil and the quickness with which the soil compacts offer good reasons for per-

mitting a much shorter time between the plowing of the ground and the planting of the crop.

The practice of growing a green cover crop of some sort and plowing it under in the spring of the year instead of in the fall is proving to be a very beneficial and profitable process for sandy land, particularly if those cover crops are nitrogen bearing plants, such as clover, etc., simply because being plowed under in sandy soil, they form a sort of reservoir for holding moisture as well as yielding nitrates. The fact that sand does not form clods or large air spaces makes a practice of this kind profitable on sandy soils in the spring whereas it would prove detrimental on clay soils on account of the tendency of these soils to form clods and air spaces on the bottom of the seed bed.

CHAPTER VI

Depth of Plowing

DEPTH of plowing has been argued pro and con for many years. A depth of six inches is regarded as deep plowing by some and shallow by others. In this discussion two to four inches is regarded as shallow, four to eight inches as medium and eight to sixteen inches as deep plowing. The question that interests every farmer and one that he must decide for himself is whether he shall practice shallow or deep plowing on his farm, and not what his neighbor regards as deep or shallow plowing. One farmer makes great success of deep plowing, another plows just as deep and meets with dismal crop failure. One farmer plows deep in the fall and grows a good crop the next year, another plows just as deep in the fall and has a dismal failure the next year. The same results are happening in deep spring plowing. These being facts beyond dispute, something besides the mere act of plowing must be taken into consideration before a conclusion can be reached.

Advocates of deep fall plowing center their arguments around the theory that deep plowing in the fall turns the raw earth to the surface giving it the advantage of the winter's freezing and atmospheric influences to bring into play the fertility which is supposed to have lain dormant or in unavailable form. The experience of those who have deep fall plowed with disastrous results the next year would tend to disprove this theory. The fact that many men have deep plowed in the spring with successful results would tend furthermore to prove that fertility is made available by deep plowing in the spring.

These observations tend to the belief that those who plow deep in the fall with bad results the next year, must not have had fertility on the surface of the plowed field or the winter's freezing destroyed it, and further that the deep plowed field in the spring contains fertility.

If one regards these deductions as logical, the question as to whether one should plow deep or shallow in the fall or spring must be solely determined by the condition of the land. The farmer must be absolutely certain that he has the plant food elements in the soil either in available or unavailable form, and also whether freezing influences are necessary for the liberation of that food. How can this be determined?

It is doubtful whether samples taken from the surface of a plowed field and examined by a soil chemist would be of any practical value to the farmer for the simple reason that the soil chemist would be unable to tell as to the availability of these elements in the soil. The most the chemist can do is to determine the amount and kinds of elements that are in the sample submitted. These deductions are apt to be entirely wrong as far as the quantity over the whole field is concerned.

It is a question whether any man by following this method can ever be sure as to what the soil needs on account of the uncertainty of the amount of plant food elements of all kinds existing in different portions of the field. A much better way for a farmer who is not positive as to what he is going to accomplish by deep plowing is to do a little experimenting of his own. It can be done very successfully providing the experimenter has learned how to handle the different soils as discussed in Chapter V.

Take five potfuls of soil from the field and test for the elements required to grow the crop. In each of these pots plant a few seeds of the crop desired to be grown. To the first pot add nothing, to the second, a quarter teaspoonful of sulphate of potash, or if that is not obtainable use a teaspoonful of wood ashes. To the third pot put a combination of the phosphate and potash, to the fourth a quarter teaspoonful of sodium nitrate or ammonium sulphate, and to the fifth a combination of acid phosphate, sulphate of potash and



Whether the ground is plowed deep or shallow the condition of the earth shown in this cross section of a plowed field must obtain before the seed bed can be made a success. Deep plowing often shows a good surface and hides a bad furrow bottom.

sodium nitrate. This sort of test is not, strictly speaking, scientifically accurate, but it is close enough to show anyone which of the three principal plant food elements, phosphorus, potash and nitrogen, are lacking in the soil.

If the plant in the first pot refuses to grow, it is plainly evident that the soil is lacking in plant food elements. The growth of the plants in each of the pots will signify in what the soil is lacking and what will be necessary to

add to that soil before it will produce. It is further logical to assume that if the best growth takes place in those pots that contain fertilizer or the plant food elements which the farmer cannot hope to add to the soil, it is unwise to plow the ground to that depth whether he does it in the fall or spring. We often deceive ourselves into thinking that soil plowed eight, nine, or ten inches deep turns up soil fertility when it does not.

As far as the writer has been able to learn, there have never been experiments tried to prove that winter's freezing unlocks soil fertility any more than that the winter's freezing of certain soil particles such as clay, has a tendency to flocculate the soil, or break it into small particles, so that the fertility contained in the soil is made more available.

Obviously then, one must suppose that before deep fall or spring plowing is indulged in it is necessary to know whether the deep soil contains available fertility.

The other important question to decide is whether or not the plowing can be done so as to leave the ground in the proper tilth and condition for plant growth. This can only be determined by having a knowledge of the soil and how to handle it to bring about conditions of tilth.

The one great advantage of deep fall plowing over deep spring plowing is that the fall plowing receives the aid of time, moisture and freezing to break up cloddy formations that may have resulted from the plowing and to compact the soil into a suitable condition for capillarity to take place. In deep spring plowing, the ground is often turned over in cloddy formations which are detrimental to the compacting of the soil at the bottom of the furrow on account of the depth at which it must

be worked. The result is a seed bed with a poor capillary connection with the sub-surface. This fact, and also the fact that barren soils are often turned over make deep plowing in the spring questionable in a great many localities, but where the soil can be turned over in a friable condition and contains abundant plant food, there is little to worry about deep plowing in the spring providing the seed bed is compacted as it should be.



This depth of plowing attempted with a bottom designed for medium depth plowing reveals a badly turned furrow slice, poorly cleaned furrow bottom. The illustration on the next page shows a side view of this plowing.

Deep plowing cannot be done successfully with a plow having a capacity of not more than seven or eight inches in depth, because it cannot possibly break up or pulverize a deep furrow. This fact should be taken into serious consideration by anyone who attempts to do deep plowing if he expects to plant a crop soon after the plowing is done. Its curvature and shape will permit the passage of thick slices over the mouldboard. But when the plow is penetrating a depth beyond its capacity it pulverizes poorly to that depth and the rest of the slice is broken into clods which are usually thrown on the bottom of the furrow. For this reason one who expects to turn a depth of eight inches or more should secure a plow with a bottom designed for this type of plowing.

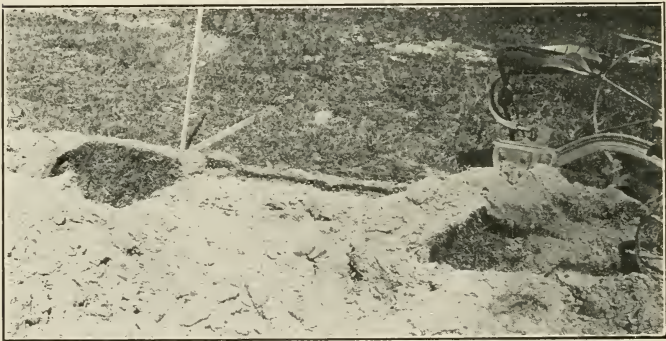

Part of the furrow is turned on edge and is almost ready to fall back.

Attempting to use a plow having a capacity of eight inches in those soils that stick together has a tendency to set the furrow slice on edge and oftentimes the furrow slice rolls back with the sod on top. Thus, the furrow itself effectively offsets any influence the plow bottom may exercise towards pulverization. This fact also accounts for a great deal of deep plowing failure because



Plowing eleven inches deep with a bottom made especially for deep plowing. Observe the clean furrow, smooth furrow bottom and wall, and the furrow slice turned over properly. This plowing is in great contrast to that illustrated on page fifty-five. On account of the depth at which this plow is working the greatest of care should be exercised to see that the bottom of the furrow is properly made because none of the after preparation implements such as the disk harrow, peg harrow, or roller pulverizer can exert much influence on the bottom of the furrow.

the seed bed is left in such a manner that moisture cannot come up from below by capillary attraction and that which is on the surface either washes away or sinks into the subsoil where it cannot rise again.

We must remember whether we are plowing shallow, medium, or deep that the ground must always be left in condition at the bottom of the furrow for capillarity to take place with the subsoil. We cannot judge this by looking at the surface. It is necessary to dig into the ground the depth of the plowing and observe the condition. When we do this we will often see things that surprise us, and the explanation for many a deep plowing failure can be satisfactorily found.

The great advantage of deep plowing is that it offers deeper root beds for the crops. The mellowed ground is the easier the roots grow and penetrate.



Side view of the deep plowing with the proper bottom illustrated on page fifty-seven. Observe how this soil is being turned over. The crack through the center of the furrow slice shows the immense pressure being exerted to pulverize the furrow slice from top to bottom. Observe also in the plowed field the lack of large clods and holes. The manner in which this bottom forces the top of the furrow slice against the ground and then crushes it as the plow advances is obvious.

With the deep plowing the plant has the additional advantage of getting farther into the ground, thus enabling it to drink in more plant food and have the

advantage of more moisture in the drier season of the year. This season is nearly always the flowering time of the plant, and accounts in a large measure, for the additional crops that are grown on deeper plowed seed beds which are properly compacted and cultivated on the surface for the retention of moisture.

It is equally obvious that if the deep plowed ground is not compacted properly on the start for the retention of moisture and improperly cultivated, or not cultivated later, that the deeper the seed bed the more moisture will escape.

Chapter V on handling soils brings out the fact that the water holding content is determined by the size of the soil grains, hence, we can expect sandy soils to dry out much more rapidly than clay soils and thus produce less unless the proper precautions are taken to save the moisture.

Sandy soils have less fertility to turn up in deep plowing than clay soils, hence a farmer who has any type of a sandy soil should be very careful in his plowing to see that the plant food elements are in the surface after the ground is plowed if he has to put them there by means of artificial fertilizers. The very nature of sand prevents it from puddling and forming clods, but is propitious to the rapid escapement of moisture.

A grave question arises in deep plowing as to the value of spreading a heavy coat of manure on the surface and turning it under providing the plowing is done deeper than the habits or customs of the roots of the plant for penetrating the soil. If the soil above the spread manure contains sufficient fertility to grow the crop it is easy for one to deceive himself into thinking that he has accomplished a great deal by turning under

the manure. As a matter of fact, any manure that is spread below the roots is of little value to the plants because if there is sufficient moisture in the ground to raise what plant food may come from it in solution, there will be a sufficient amount of water in the ground to permit it to leach away, hence, the chief value of manure as fertilizer is lost.

Another serious objection constantly happening is that a very heavy coat of barnyard manure is applied and turned under in such a way that nitrates form too rapidly in the spring on account of the ammonia content of the manure and later in the season change into unavailable forms thus destroying the influence of the manure, leaving the remaining part dry and in a form that is hard to dissolve. This is what our scientists term burning the soil. This dry, insoluble form of fertilizer at that depth in the ground interferes most seriously with the upward trend of moisture and retards growth to that extent.

While there is no question but that ultimately the soil will be benefited by turning under manure at this depth one can diminish a crop or lose it by a too zealous application of manure at this depth, particularly if the application is made close to planting time.

It is easily possible for a soil that contains fertility to be plowed deep in the fall and so improperly handled the following spring that a crop cannot grow. For this reason if a test with the soil pots proved that there was plenty of fertility in the soil and the crop next year proved a failure, it naturally follows that the deep plowing in the fall would not be responsible for the failure. This is not a mere hypothesis but has happened many times when the failure of the crop has been wrongly at-

tributed to deep fall plowing. The preparation of the seed bed the following spring was the fault. The logic in the reference to the preparation of fall plowed ground in the spring is just as applicable to the deep fall plowing as the medium depth plowing because air and moisture must be properly proportioned the full depth of the seed bed.

Another benefit that can be derived from deep plowing is the eradication of weeds. Shallow plowing very seldom does anything except to more effectively plant weed seeds. When plowing is done to effectively bury all vegetation and seeds deep in the ground it is impossible for the majority of them to sprout and reach the surface before the crop which is planted above them can sprout and reach a good growth. This fact is due to the peculiar nature of plant growth.

There is no reason to believe that weeds should grow any faster than other plants unless conditions for their growth are more favorable. This is the reason why certain kinds of grassy weeds appear in the blue grass lands when the blue grass itself is drying out from lack of moisture. To put it another way, these grassy weeds flourish with less moisture than blue grass does. To get rid of weeds means to keep the ground in a condition for the more favorable growth of the plant that the farmer wishes to grow.

Deep plowing in the spring of the year puts the weed seeds so far down with the turned surface that the ground is cooler than that above, hence the sprouting of the seed is retarded. If the surface soil is cultivated at the time it should be, the surface of the ground will be warmer by the evaporation of moisture and the crop can be planted and receive a good start before the weeds



Plowing done in this manner deeply buries all the trash in the furrow, leaving a clean surface for the final preparation of the seed bed. Observe the very weedy condition at the left and the entire absence of weeds protruding between the furrow slices. It is doubly essential in deep plowing that all the weeds be entirely covered to prevent the formation of large air vents from the top of the seed bed to the bottom.

can interfere, thus the weeds will start and provide food substance for the plants. The deep fall plowing of weedy ground will naturally result identically the same as the spring plowing, but with this additional advantage, if the ground is plowed sufficiently early in the fall and enough rain falls the weeds will sprout and grow in the fall and be killed by the winter's freezing.

CHAPTER VII

When to Plow

THE reader who has carefully perused the preceding pages has observed that fall or spring plowing is not an academic question to be decided by debate. But one which must be decided by every farmer.

Enough has been said to bring out the important fact that as a rule clay soils are better plowed in the fall and sandy soils in the spring. However, many contributing factors such as humus, freezing, amount of rainfall, plowing under green crops, moisture conservation and killing insects and weeds enter the problem. No man except the one who understands the soil under consideration and purpose of plowing can give an opinion worth while.

As a general rule fall plowed ground can be worked earlier in the spring than unplowed ground. Nature has a curious habit of causing plants to grow and prosper in certain seasons of the year. The nearer crops can be planted to that season of growth the greater is the prospect for a successful crop. Late and backward springs often prevent the planting of the seed until quite late. The fact that fall plowed ground left in a rough state dries out much more rapidly in the spring than unplowed ground gives the advantage of getting onto the ground earlier in the year. This offsets in a measure, the baneful influence of a backward spring and also enables the farmer to do his disking and harrowing

oftener if necessary to put the ground in a better condition of temperature for the sprouting of the seed.

Time is the determining factor. Oftentimes when plowing should be done so as not to form clods, the farmer is exceedingly busy at some other task, usually harvesting or cultivating. Naturally the plowing waits.

There is always some season in the year when ground can be plowed without the formation of clods. For this reason those who expect to get the most out of their plowing will take that into grave consideration. It is a peculiar fact that plowing is usually done in certain seasons of the year because of habit and necessity.

No one who contemplates building a house would ever think of laying the foundation in the winter when freezing would ruin it before the house could be built. It is just as illogical to plow the ground when it is not in condition for pulverization as it is to lay a foundation in the winter, providing Nature does not have time to do the pulverizing before the crop is planted.

This old idea of spring plowing, fall plowing, and summer plowing will have to give way to plowing when the ground is in proper condition for it, particularly in the heavy types of soil, if the crop is to have the benefit of the best start possible.

If plowing is done at the last minute, the ground is either in first class condition for pulverization, too wet, or too dry and hard. The chances are one in three of finding the ground fit. Consequently, plowing cannot be put off until spring or fall if advantage is to be taken of right conditions for plowing.

Unfortunately it has been the habit for years and years to put off plowing sod, cornfields, and very many

stubble fields until spring. In other words, the bulk of the plowing is left for spring work. This, in the light of present day experiences, will have to be entirely reversed or the maximum crops can never be grown.

Wet spring plowing of clay soils always gives the crops a poor start and makes after cultivation practically impossible for the development and liberation of plant food, particularly if the cultivating season is dry. It is a matter of history that most wet springs are followed by dry summers. Wet spring plowing of sandy soils means the leaching away of plant food elements that should be retained for the growing crop.

The plowing of clay soils in the spring when they are too dry and hard means plowing either a field of clods or else turning the soil into a finely powdered condition which becomes plastic upon the first rain. Plowing a sandy soil when it is too dry means further escapement of moisture. Therefore, plowing either when too wet or too dry in the spring means a curtailment of the crop.

The following information on corn and oat growing shows why an understanding of the crops to be grown and the physical condition of the ground necessary to grow these crops should be considered before plowing.

Corn requires 271 tons of water to produce one ton of dry substance. This means 2.39 acre inches of water. In other words, it requires 2.39 inches of water to grow one ton of corn. It has been demonstrated that too little or too much rainfall at flowering time is injurious to the crop. If the corn grower expects his crop to have this water just exactly as the plant needs it, neither too much nor too little at any one time, he must of necessity

plow his ground and cultivate to keep the surplus away from the surface, but in such shape that the plants can draw upon it.

The illustrations on the opposite page are photographs of an experiment to bring about the value of plowing in July for fall wheat. This land was a light, sandy and gravelly river bottom loam poorly adapted to small grains. The farm was situated in the northern part of Indiana. The field treated in this manner showed an increase of twenty per cent. over the rest of the field which was plowed early in September in the ordinary manner. The seeding and fertilizing over the entire field were exactly alike.

No. 1—The field plowed on July 18. Observe the foul condition of the unplowed ground. It is full of milk weeds and dock.

No. 2—Later in the day the disk harrow and pulverizer were called into play to put the seed bed in shape.

No. 3—Observe that the weeds are buried deep in the furrow and the disked and rolled section is compacted away from the unplowed section showing that the seed bed is compact from top to bottom.

No. 4—Photograph taken June 25, the following year. The portion of the field plowed, disked and rolled. Observe the lack of milk weeds and dock.

No. 5—A few of the wheat heads selected at random from the field shown in No. 4. These heads produced twenty per cent. more per acre.

No. 6—The section of the field that was plowed and harrowed in the ordinary manner. Observe the appearance of milk weeds. This section was photographed the same day as the field shown in No. 4.

No. 7—A few of the heads selected at random from the portion of the field shown in No. 6. Observe how much bigger and better the heads are in No. 5.

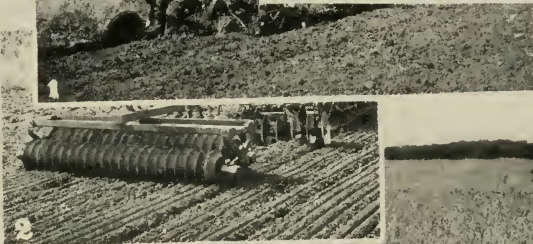

Corn also requires in the vicinity of three thousand degrees of heat to complete the crop from start to finish. Anyone can readily see that if three thousand degrees of heat were applied in one stroke to the field what would happen to the corn. This amount of heat must be scattered over the period through which the corn grows.

This heat has to do with the development of plant food, its conservation, and the ability of the corn plant to partake of that food. It also has to do with the amount of moisture that falls and is consumed. Unless ground is in physical condition for heat to work to the best advantage in doing its labor and also to enable plant food to develop as the plants need it a maximum crop cannot be grown regardless of how fertile the land may be.

A study of soil conditions has revealed that ground, mellow and friable, to a depth of at least six inches is required at the start for bringing about the condition mentioned. Seven and eight inches have proven to be better. This naturally means that this portion of the ground cannot be full of large and coarse dead vegetation in a half decayed form because it interferes with the upward trend of moisture which is necessary if the corn plant is to receive the proper amount of moisture by capillarity for the manufacture of plant food.

It naturally follows from this that ground covered with dead vegetation for planting corn should be plowed deep and the vegetation buried deep in the ground so as to interfere as little as possible with the upward trend of moisture.

It is particularly desirable in spring plowing to bury this trash deep enough so that it will not pull out and interfere with after cultivation. Burying cornstalks

deep in the corner of the furrow places them where they will do the least possible damage in the way of interfering with capillary attraction, where they do not interfere with after cultivation and in the right place to decay in the soonest possible time, because the water trickling down between the furrow slices has an easy approach to them.

The oat requires 504 tons of water or 4.45 acre inches to grow a ton of dry substance, and approximately 2,100 degrees of heat. The plant food elements that enter the make-up of the oat do not require so much heat for their manufacture as those of the corn plant. This has led to the statement that oats do not require heat and also that oats do best in a moist and relatively cool climate. It naturally follows that if the seed bed is put in condition for the successful manufacture and liberation of plant food as the plants need it and the ground kept in shape so that it will always be relatively cool during the growth of the oat plant, one does not have to worry about the cool climate.

We often hear that an oat crop should be planted as early in the spring as possible and that an early frost clipping the green plant does not do any real damage.

The real reason why scientists advocate the early planting of oats is on account of the cool condition of the ground necessary for the development of this plant.

Plowing for oats brings up an interesting question and one that every oat grower can ponder upon with profit.

Is it necessary to plow for oats or can the ground be disked and a good crop grown?

We hear diversified opinions as to the results. One year farmers maintain that plowing increases their

crops abundantly and another year they contend that disking without plowing produces a better crop. Back of it all is this one fundamental fact—the ground which was in the proper condition for the growing of the oats grew the best crop.

How is one to tell whether to disk or plow for an oats crop? It is not so hard if one stops to consider two fundamental facts. The first is that moisture keeps the ground from readily warming in the early spring; the second, it keeps the ground cool in the hot summer weather.

The seed bed must be made so as to warm the ground as early as possible in the spring and keep it cool during the warmer weather. To do this naturally means that the ground must be put in condition to conserve the water and prevent the ground from running together in a plastic condition in the spring of the year.

If the winter has been very severe and the ground full of frost, this condition may be brought about by merely disking in the spring because freezing expands the soil particles, leaving them loose after thawing. If, on the other hand, one waits until spring to plow, and the spring should be late, he may be losing time that ought to be consumed by the plants in growing because the plants should get all the growth they possibly can before the warmer days that are coming. If the ground for oats is left cloddy, half pulverized, it cannot grow a good crop of oats, and on the other hand, if the disking is done when it is hard below the surface a good crop of oats cannot be grown unless Nature is very propitious with hard rains and cool weather, but, however the work is done, the ground must be in the proper shape for

percolation of the moisture downward in the spring, and its upward trend by capillarity later in the season.

These two illustrations should show the importance of paying the closest attention to plowing at the right time. The same laws hold true of any crop.

CHAPTER VIII

Plowing to Kill Insects

PLOWING to kill insect pests is a most important job for every farmer. It is the ounce of prevention worth the pound of cure in the pest evil. It kills insects before they can do harm, and the cost is nothing. There is no farm in the length and breadth of the land that is not some time or other afflicted with insect pests of the most ruinous type. One must not expect that all kinds of insects can be killed with the plow. Most of those which commit the greatest depredations can be eradicated with the use of the plow. However, before one can put insect pests out of business effectively he must know and understand the life and characteristics of the pests just exactly as he must know the life and characteristics of plants and weeds.

The most effective methods for getting rid of pests are to break up the breeding places, starve them to death and make impossible the hatching of insect eggs. These three methods can be successfully worked by the use of the plow if the work is done at the right time and the ground cultivated to keep down all green growth.

It is generally agreed among our entomologists that there never would have been such inroads of insect pests in the field had it been plowed at the right time of the year so as to cover the trash deep in the furrow. Leaving stubble, such as grain, corn stalks, cotton stalks, etc., on the surface affords the most propitious protection for

insect pests that feed upon these plants. Year after year they continue to thrive.

All insect pests that can be killed with plowing pass the winter either in the trash on the surface of the ground or burrow down below the frost line. The pests that burrow down below the frost line are usually in the larva or grub state. Those that stay on the surface in the trash are mostly full grown insects.



The stumpy ground, the poor covering of trash, and unevenly plowed ground, are conditions favorable to the growth of insects.

The numberless varieties of weevils afflicting the south usually pass the winter without food in the rubbish near their feeding ground. They start hibernating at the first frost and quickly come out as the weather warms and then they return as it cools. Weevils do not lie in green rubbish nor do they seem to possess any sort of instinct as to how and where to go to find the cotton fields. Strong winds blow them many miles. Standing stalks of all kinds in infested fields furnish the most favorable conditions for the hibernation of weevils. Obviously if

these fields are plowed, as soon as possible after the crop has been harvested, deep enough so that the stalks will not appear above the ground and the surface of the field kept clean there is not much opportunity for a weevil to survive in that place. All the neighbors doing this kind of plowing, cutting down weeds and grass in the fence corners and burning them, seeing to it that the trash and surface vegetation near the cotton fields have all been burned, aid very materially in reducing the boll weevil pest.

An entirely different sort of plowing is necessary to get rid of the white grub. The white grub is lazy, that is he will stay on the surface of the ground as long as he



Contrast this field and plowing with that shown on page seventy-three. The thorough covering of cotton stalks and the mellow condition of the soil mean that this farmer is giving his crop the best start possible.

can and gradually work his way downward as the weather gets cooler. The white grub lives for the most part in timothy meadows. The question that confronts the farmer is whether he wants to use the meadow for pasture in the fall, plow the ground the following spring and run chances of having the grubs destroy his corn, or plow to get the grubs. After they have attained their full growth they are nothing more or less than the common May beetle or June bug.



These four white grubs were found in a square foot of timothy sod. When anyone learns their characteristics it is a comparatively easy matter to keep them from doing a great amount of harm.

The time to plow to thoroughly get rid of white grubs is when the grubs begin to bury themselves in the ground. Plowing the ground at that period and turning all the hogs, chickens and turkeys into the field to feast on these grubs will rapidly diminish their number. If the plowing is done late enough frost helps in the killing.

The proper remedy for getting rid of the Hessian fly is first to plow immediately after harvest, burying the stubble as deep in the ground as possible and to keep the surface of the ground well cultivated so as to elimi-

nate lumps and clods to produce a finely compacted and moisture conservation seed bed. This process destroys all volunteer plants which may grow and furnish a means for propogating the fly. The principal step in this process is to plow deep and cover all the trash.



The crooked furrow, if the ground is trashy, is propitious for insect breeding. It is impossible to always plow the proper width of cut and as a result the furrows are not laid properly to cover the trash, and keep the ground from drying out rapidly. Trash and air vents in the ground are good incubators for insect eggs. The two combined keep out moisture, the greatest hinderance to insect eggs hatching.

Cutworms, like white grubs, live in soil that has been in grass for a number of years. Meadows infested with cutworms should be plowed early the previous fall. The earlier in the fall the ground is plowed the less probability that the cutworm moths will have laid their eggs, consequently the injury from cutworms the following year will be diminished. Late fall and winter plowing is not so effective as early fall plowing for the eradication of the cutworm.

Land infested with billbugs should always be plowed in the late summer or early fall. Plowing at this time breaks up the winter lodging of the bugs. A study of the life of billbugs shows that they also live on many different types of grasses. Therefore, it is necessary for the eradication of the billbugs to plow infested grass fields lying next to the other ground.

These instances are citations to show the necessity for studying the habits and characteristics of insect life before one can successfully combat it with the use of the plow. The loss that is sustained by farmers on account of the destruction of such bugs as the boll weevil, white grub, wireworm, grasshopper, Hessian fly, cutworm, army worm, etc., is estimated by some authorities in excess of five billion dollars annually.

To kill some of these insects it is necessary to plow the ground while other very important tasks occupy the attention of the farmer. The necessity for a means to do this work at the proper time arises. The solution of the problem lies in the means the farmer has in his hands for doing this work when the time comes.

A great deal has been said about crop rotation for the control of insect pests. All this is good but the first thing in the eradication of bugs of any kind whatsoever is to plow the ground thoroughly, seeing to it that all trash is buried deep, leaving none on the surface. Of all types of insects that can be eradicated by plowing it is far better to turn the stubble under immediately after the crop has been harvested than to burn it. All of this trash represents a vast amount of fertility that has been taken from the soil, and is much better for the ground if it can be put back as humus. The best and most



Cultivating orchards helps to keep the farm rid of many bad insect pests that hibernate in such places during the winter as well as keeping the weeds and grass from consuming plant food that should be utilized by the trees in developing good fruit. When we learn to keep weeds down and trash burned on all parts of the farm our insect troubles will begin to disappear.

effective time to bury trash for the eradication of bugs is when it produces the best humus.

Dry vegetation buried in the ground is harder to rot than green. The rotting of this vegetation helps along in the destruction of insect eggs so that the work is complete. It is a self-evident fact that if there is enough fertility and the soil particles are arranged so that fermentation is taking place in all parts of the seed bed it is impossible for insect eggs to hatch, hence the desirability of plowing under this vegetation while it is in a green state.

CHAPTER IX

Plowing to Kill Weeds

WEEDS, like the proverbial poor relations, are always with us, and they always will be. The damage done by weeds is roughly estimated at one billion dollars per year. It can be easily diminished to a very small sum if proper precautions are taken. One must study the habits and characteristics of weeds for their destruction in the same way that he must study the habits and characteristics of the plant that he desires to grow. Nature acts upon the principle of the survival of the fittest. Therefore, the farmer must till his land to bring about a condition that gives the crop he intends to grow the advantage. He can hardly expect to do this unless he understands the characteristics of both.

It would require an immense volume to treat the peculiarities and habits of all weeds and how they can be eradicated, and if a volume were written, in six weeks it would not be complete because Nature is constantly bringing forth new varieties of weeds with considerable less gusto than man produces new varieties of grains. For this reason farmers must not always expect to find the answers to their queries written in a book. Indeed, they will seldom be found there because climatic conditions have just as much effect upon weeds as they have upon legitimate plants. Nature does not distinguish between the two. The distinguishing is done by people whose existence depends upon the food qualities of the plants they desire to cultivate.

A most vital reason why one should understand the characteristics of weeds before attempting to eradicate them is because plowing has a tendency to cultivate certain types of weeds rather than kill them. Sorrel and quack grass are two very common examples of this type. All types of weeds that put forth a new sprout from any root joint can be eradicated by plowing if the ground plowed has the benefit of after treatment that will keep the stems from becoming exposed to the sunlight. The reason is the stems receive their nourishment from the leaves which are exposed to the sunlight. If it is possible to keep the top growth down so the leaves cannot absorb the necessary light for sustenance the plant naturally starves to death.

Those surface root weeds which can be quickly killed by cutting or burying in the ground do not cause much worry.

The three great rules to observe are first, prevent weeds from going to seed; second, prevent weed seeds from being sown on the farm; and third, prevent all weeds from making a top growth.

Farmers must not expect to keep their weeds down in the field when they permit them to grow in fence corners, along road sides, in pastures and other uncultivated fields because these seeds are carried by the wind, birds, water, and animals to all parts of the field where they are ready for a new start and in very favorable condition for germination and growth.

Our scientists tell us that annual weeds, those which grow from the seed each year, may be eradicated by any method which starts germination and then destroys the plant before it produces seed. Biennial weeds, or those that live two years between the germinating of the seed and the maturity of the plant, require an entirely dif-



A field plowed in July so as to completely bury the weeds in a corner of the furrow. Wheat was planted in the fall.

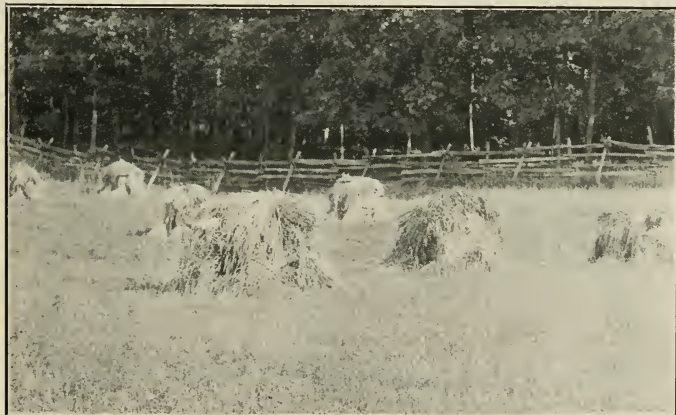

The following year this wheat crop was harvested without any of the weeds turned under the previous fall appearing in this stubble.

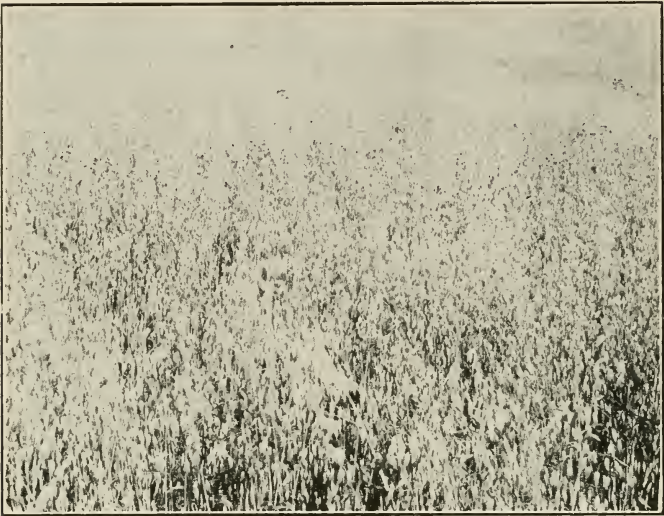

Result of a portion of a field plowed with the combined rolling coultter and jointer attached to the plow.

ferent treatment. The habit of cutting the tops of these plants is not always the most desirable method because very many of them will put out new leaves and produce seeds, consequently, if the cutting method is practiced the tops must be cut sufficient times during the season to prevent the plants going to seed. Perennial weeds, or those that grow from the roots, are the most difficult to handle. A method of cultivation that will expose the roots to the surface, and prevent them starting growth is the most successful.

In all these different types of weeds one striking fact stands out. That is both weed and legitimate plants require the gases from the air which must come in through the leaves and stem. This being true the first course in the destruction of weeds is to prevent this food

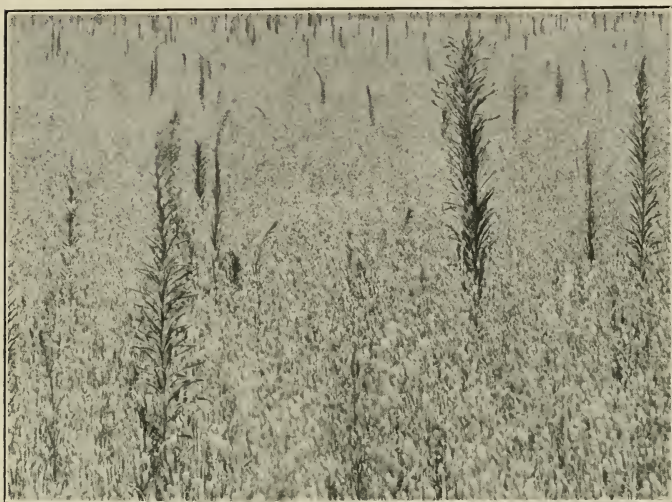

A portion of the field shown on page eighty-two plowed with the same plow without the combined rolling coultter and jointer. These tall weeds were thick all over the field when the ground was plowed preparatory to growing this crop.

assimilating process. It is a difficult task to attempt to do this work by hand in large fields. The work must be done with tillage implements.

The first step is to fall plow as deeply as it is possible for the plow to operate. The deeper the weed seeds are turned under the better. Every leaf, stem, and all the seeds must be turned to the bottom of the furrow. For this reason it is unwise to disk such ground in the fall before plowing it. Experiments have been tried which proved beyond a question of a doubt that the action of the disk harrow in ground of this kind has a tendency to sow the seed rather than eradicate it, while leaving the surface of the ground unmolested and turning all surface trash completely under with a plow has rid a field of all classes of weeds.

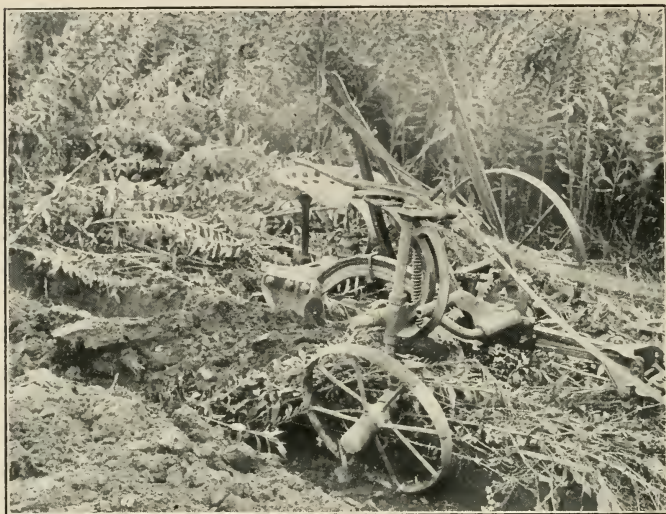

A field of tall weeds being turned under with a plow having a combined rolling coulter and jointer attached.

The combined rolling coulter and jointer for this work is the most valuable addition to the plow. This device turns all the surface trash and weeds into the lower *right-hand corner of the furrow. Turning them under deep in this manner means that the new shoots which the seed will send forth take additional strength and nourishment from the root system before they can reach the surface. This growth impoverishes the root, thus the growth is retarded and the weeds' vitality weakened.

If the plowing has been done at the right time in the fall the winter's freezing will come along and kill the tender plants. If the weeds are of a variety that will come up very soon after plowing, the infested field should be plowed early in the fall and when the weeds come to the surface and begin developing leaves, surface cultivating of the ground with the weeder or disk harrow



The identical spot in the picture shown on page eighty-four taken the following year. This field had no hand cultivation, simply that of a one-row horse cultivator. None of the varieties of weeds turned under appeared in this field.

will immediately destroy the weeds. The great trouble with unsuccessful practices of this kind has been the failure to carry the after work through carefully enough to kill all sprouting weeds. Quack grass has been successfully eradicated by this method but the operator did not permit a single leaf or stem to develop. In one instance the farmer, after plowing, kept up this cultivating operation from spring until fall. He wanted to plant corn on that field but his greater ambition was to kill the quack grass, so he kept cultivating until fall and sowed the field to fall wheat, reaping a much better crop than he would have had he planted corn, and he entirely rid the field of quack grass.

The secret of his success lay in the fact that he kept the stems and leaves from drinking in the sunlight to sustain the roots. The result was the root system started to rot as it will do with all weeds just exactly as it does with other plants.



Sectional view showing weeds buried in the lower corner of the furrow deep enough to prevent their getting a good growth in the fall before the winter's freezing will kill them. If the same plowing were done in the spring the crops planted above would sprout and grow before the weeds could get a start.

In this weed killing process a farmer may often be obliged to choose between the loss of his ground for a year or the growth of such a crop as he can expect to raise in a weedy field.

*This reference means when right-hand plows are used. When left-hand plows are used the weeds should be in the lower left-hand corner.

CHAPTER X

Plowing Under Green Manure

ONE is often troubled as to the proper time to plow under a green manure crop. The answer centers around the quickness with which a crop is desired.

It is common knowledge that a green plant turned under will rot quicker than one that has reached maturity, and is in a dry condition when plowed. Evidently then, the time, if quick results are desired, is to plow when the crop is in a green state.

Scientists tell us that the best time to plow under a green crop, if it is clover or some other legume, is just before the blossom shows signs of turning. The reason is the stems and leaves are in the green, or sugar state and contain more of the plant food elements than the crop that has not reached this period of growth. Plowing under a green crop any later than this means that the plant has reached a fibrous and starchy condition and is much harder for moisture to dissolve. Obviously more time will be required to reach a state when fermentation can set in.

The clover plant moves much of the sugar from the leaves and stems into the roots and stores it there in the form of starch for the winter. In this condition clover is more resistant to decay, consequently, when plowed late in the fall there may not be enough time for the plant to decay before the crop is planted. For this reason it is always advisable to plow clover under in

the green state. Regardless of the time of the year that plowing is done, decomposition will proceed faster if the matter plowed under is always green. Hence, the ideal time for plowing under a crop of green manure would be to do the plowing at a time of the year when the crop is green.

If the location is such that there is a scant supply of rainfall a heavy green manure crop plowed under after it reaches the starchy stage can ruin the following crop. It has been known to do so in a great many cases although it is a question whether the farmer, whose crops were ruined, understood the reason for it.

To cut a heavy crop and leave it lying loose on the ground before turning it under loses an immense amount of organic matter. The principal object of plowing under green manure is to put organic matter into the soil, hence there is nothing gained by plowing under vegetation if it is mowed and left standing on the field. It is far better to plow under the green crop without cutting it. In this way all the organic matter is placed in the soil in the proper condition.

Spring plowing of rye sown in the early previous fall is apt to cause trouble in the clay soils if the field is pastured in the early spring and the ground happens to be wet and later on when desiring to plow, the weather turns off dry, because the ground is packed hard and will not break into a friable condition. If rye is permitted to grow until late in the spring and then plowed under it is very likely to break up capillary connection with the sub-surface and keep the ground so that it will interfere very seriously with the crop from feeding on what nourishment already is in the ground.

A problem arises when plowing stubble with the idea of making fertilizer out of it when the ground is so dry and hard that there is little opportunity for enough moisture to come up from below to rot the stubble turned under. Since moisture is the only means to rot this turned over stubble it is absolutely necessary to bring about a condition in the ground whereby moisture can come up from below. Obviously then, plowing should be done to see that the trash is buried as deeply as possible on the bottom of the furrow in such a way as to interfere as little as possible with the upward trend of moisture.

Fertilizer crops of all kinds must always be plowed under with the idea of their becoming well rotted and decayed before the crop is planted.

If the soil which the farmer desires to turn under is of a loose, ashy-like composition and the rolling coulter will not cut through the vegetation, a condition is met which is exceedingly difficult to handle.

Soil of this kind is always lacking in humus. The time that one usually desires to plow these fields is when they are dry and in the ashy condition. If a strict watch is kept upon the rainfall, and the ground should be moist at the plowing depth during the growing period of the cover crop, the ground can be plowed when the moisture is sufficient to hold the soil together. Every man is the best judge of his own farm in this respect.

The reason for the ground being in the dry and ashy condition is its lack of organic matter or humus.

The purpose of growing the green manure crop is to put this organic matter into the soil. If the plowing is improperly done and the crop poorly plowed under the



Burying fertilizer at this depth, ten inches in the ground, will do a grain crop planted on the surface little or no good. Buried in this manner manure will not stop the upward trend of moisture to any extent but if it were scattered across the furrow bottom as is usually done the upward trend of moisture would be stopped sufficiently to ruin a crop in a dry year.

greatest good cannot be secured from the cover crop. This ashy condition cannot exist if the soil contains a great quantity of organic matter, hence the very purpose

plowing under green clover is to accomplish is defeated unless it is thoroughly covered when plowing.

The principal reason why farmers mow green crops before plowing them under is because of their inability to successfully cover them with the plow. With the advent of the combined rolling coulter and jointer this difficulty is overcome. This attachment on a plow will turn under the rankest growth of green vegetation more efficiently than dry vegetation can be turned under in the ordinary manner.

CHAPTER XI

Judging Plowing

WHEN one considers that different soils must be plowed in a manner to accomplish the desired results, it becomes self-evident that it is impossible to lay down a certain set of laws or rules to determine what constitutes prize plowing. The most beautiful job of plowing on the surface is not proof that the ground will grow the best crop.

Before a perfect job of plowing can be done the following requirements must be fully met.

Each furrow must be straight from end to end.

Back furrow must be slightly raised and all trash covered.

The top lines of the furrows must be uniform without breaks or depressions. The top of the furrow may be slightly ridged. Ground must be thoroughly pulverized from the top to the bottom of the furrow; no air spaces anywhere in the furrow slices.

Trash must not be visible in the line of furrow and should be buried in the lower right-hand corner of the furrow.

Furrows must be uniform compared one with another.

The depth of all furrows must be the same and continue a uniform depth.

Dead furrows must be free from unturned ground.

The above rules are recognized as the standard by which plow contests are judged. It is obvious that



This picture of fall plowing and the two following were taken in the same field, on the same day, the different appearances of the soil being caused by the curvature of the mouldboards of the plows doing the work. The soil was a clay loam. If the ground were to be left as plowed through the winter it is obvious that this kind of plowing would be better than either of the other two because being rough it would not run together and become compacted by the spring thaws and rains.



This field can be easier worked into a seed bed than that shown above but not so easily as that shown on page ninety-four, hence it would not be regarded so good plowing for spring planting or immediate seeding as the other two.



If this ground is to be seeded immediately it is plainly apparent that it can be worked into an ideal seed bed much quicker than the two fields shown on page ninety-three. However, if this ground is to be left for spring planting and the locality happens to be one where there is a great deal of snow and rainfall, the ground may have to be replowed on account of the extreme mellowness making it apt to run together.

plowing to fulfill these requirements would not be so good for crop growing in some sections as another type of plowing that would far from fill these requirements. Hence, it would be much better for those who are deciding plowing contests to judge the quality of work in accord with the results expected of the plowing.

Plowing being done primarily for growing crops it would seem logical that the rules of plowing contests should be worded so as to promote the kind of plowing that will produce the best crops on the ground being plowed. Sod plowing should not be judged as stubble plowing; plowing for wheat should not be judged the same as plowing for corn, etc.

The second rule, back furrow slightly raised and all trash covered, is a good one to follow in clay and loam soils. It is easy to understand how these requirements



This picture shows a job of plowing in a sandy loam soil. The furrows are even in width and depth and laid to make an evenly plowed field. The back furrow is not raised enough so that it can be detected from the other furrows.



This plowing won the first prize at a plowing contest. The soil was of an exceedingly clayey nature, entirely different from the soil in the field illustrated above, yet the plowing is very similar. The field shown above was plowed in the spring, while this field was plowed in the fall.

would utterly fail in plowing sandy soils on account of their loose construction. As a matter of fact, the leveler sandy soils are left on the surface, providing the surface

is loose, the less moisture escapes from them. Hence, from a practical standpoint the plow bottom that leaves sandy soils level after plowing is better for the soil than one that leaves it ridged or crowned.

A much better way to judge plowing is to take a spade or some other sharp cutting instrument into the field and see what is happening at the bottom of the furrow. If there are large air spaces and clods the plowing is certainly poor from a crop producing standpoint. If the bottom of the furrow is covered with trash so that the upward trend of capillarity is interfered with it is also equally bad plowing.

Plowing is good when the furrow slice is well pulverized from top to bottom, large air spaces eliminated, and the trash buried to interfere as little as possible with the upward trend of moisture.

CHAPTER XII

Plow Bottoms

THE bottom is the business end of the plow. Upon its performance depends the quality of the seed bed the farmer can prepare. Since the quality of the seed bed determines very largely the start a crop gets it is obvious that a plow bottom is the vital part of a farmer's equipment. All the rest of the plow is merely for the purpose of enabling the operator to make the bottom work correctly.

When one reflects upon what has been said in Chapter V about different soil compositions, the effect of humus, lack of humus, fertility, moisture, air and heat upon plant growth the reason why one must use a plow bottom adapted to that particular kind of soil becomes plain.

Manufacturers have not yet been able to make any one bottom that can be adapted to all these different types of soil. This explains why farmers who have sand and clay soils should have both chilled and steel bottoms with entirely different shaped mouldboards.

Plow builders are doing their utmost to design bottoms that will approach the best work in all conditions under which farmers plow. They have been remarkably successful in building bottoms that will plow exceptionally well in all types of soils that have one or more common characteristics but when the demarkation is too pronounced it is necessary to change the shapes of the mouldboards in order to properly stir the soil.

A knowledge of what constitutes good plowing is necessary before one can judge whether the bottom is particularly adapted to that soil. It does not matter what type of soil a farmer is tilling, the conditions necessary for plant growth must be the same. The soil must be well pulverized and properly compacted so that air and moisture can mingle in every particle and recess at all times, whether the soil is sand, clay, loam, muck, or any other.

It is reasonable to assume, in view of the entirely different characteristics of soil, that clay would be broken into clods with the same type of mouldboard which successfully pulverizes sand.

The plow bottom is nothing more or less than a three sided wedge. The cutting edge of the share and landside are flat sides of the wedge. The mouldboard and upper portion of the share are curved and made to invert the earth. The curvature and length of the mouldboard have to do with the pulverization of the soil.

The bluffer the mouldboard is the more rapidly it will pick up the earth and turn it over. For this reason all types of plow bottoms that are used in plowing the looser soils are naturally bluffer than those used in plowing soils that stick together such as clay. It obviously follows from these two extremes that the types of mouldboards used for plowing loamy soil must lean more toward the bluff as sand predominates and toward the longer curve as clay predominates.

There are countries where it is necessary to plow clay soils when they are wet because of excessive rainfall and no frost. This calls for a peculiarly shaped plow bottom that is not very well understood in other sections of the

world. This soil is nearly always of a waxy, putty nature and holds water much the same as an earthen basin. For this reason tiling or draining has never been successful, hence a plow bottom to successfully turn this soil must turn a furrow well over, yet let it stand on a corner of the furrow slice and leave small crevices or sub-surface ditches on the bottom between each furrow. This gives excellent drainage so that the sharp top corner of the furrow can soon dry and crumble, leaving a few inches of soil on the surface that can be worked to bring about the condition necessary for the right mixture of air and moisture for plant growth.

Prairie sod is full of grass roots and decayed vegetation. This ground is plowed to start the decaying of grass as rapidly as possible. The ultimate object of such plowing, of course, is to put the ground in a condition of tilth for the successful growing of crops. The rotting of the grass being the first step the sod should be plowed to bring this about in the quickest possible time. In most soils the complete reversing of the sod is supposed to smother the stems and leaves of the grass so they rot and decay very rapidly. This must be done in a way to prevent new stems from springing up.

The success of this process depends upon plowing the ground at a season of the year when there is moisture enough to start rapid decay or a much longer time than should be necessary will be consumed in the complete decomposition of the sod. The discussion on capillary water explains why this is necessary.

The thing to remember is that regardless of the kind of grass the plant must be prevented from putting forth new stems and leaves which, as is mentioned in a previous chapter, all plants will do when air and moisture are

permitted to mingle in such a way that the root system can put forth new stems. Hence, the ideal system for plowing sod is to see that all portions of the grass plant are completely buried and the ground packed as closely around these leaves as it is possible to do in order that sunlight may be kept away from the turned over leaves.

One can rest assured that if there is a possible ray of sunlight peeping through the turned furrow where the leaf of wild and native prairie grass lies the blade of grass will grow through that hole, hence the furrow slice should be thick enough to keep out sunlight and air. If this is done effectively shallow root crops such as flax can be planted and they will act as an aid in the final breaking up of the sod structure.

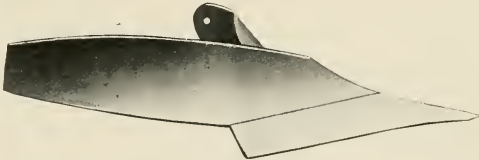

Illustration E



The kind of plowing the bottom illustrated above does. Observe the furrow slice is laid over flat to keep all the air and light away from the leaves and stems of the grass.

Special plows are required for this purpose. The shape of the share and mouldboard is such that the furrow is turned over disturbing its composition as little as possible. Illustration E shows this type of mouldboard.

The other influencing factor in reference to shapes of mouldboards is sticky soils that do not have enough body to hold together to give the amount of pressure necessary to force the dirt off the mouldboard. Naturally, in designing plows for work in this type of soil the mouldboards and shares are designed to crumble the soil as little as possible. The curvature is less pronounced than in any other type of plow bottom.

There are various ways of explaining the crumbling and crushing influences upon the earth as it passes over the mouldboard, but a very simple explanation is found in observing the distance that the top and bottom of the furrow slice travel in the process of being picked up and turned over.

It is obvious that the bottom of the furrow slice travels a much longer distance when being inverted than the top or stubble side. This process of inverting the furrow means breaking up the earth into particles. Whether these particles are broken into larger or smaller clods depends upon the tenacity with which they stick together and the shape of the mouldboard for pulverizing.

The broad principle employed in shaping the curvature of mouldboards is one that will cause the soil granules to roll one upon another and thus break their cohesion. A closely textured soil, plowed while wet, increases the cohesions of the granules so that they will not fall apart in the act of plowing. Thus a mouldboard

that does a perfect job of plowing in soil that is in the proper condition for plowing will be ruinous to this soil when plowing it too wet.

It is further obvious that those soils which must be plowed when wet require the use of a mouldboard that will break them as little as possible while being turned. This characteristic identifies those types of plow bottoms used for plowing wet soils that do not have the benefit of the winter's freezing.

The illustrations of the following plow bottoms will suffice to make clear the efforts being put forth to build bottoms suitable for all conditions.

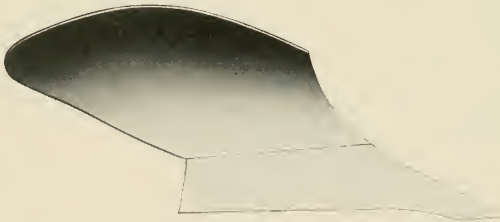

Illustration F

Illustration F shows a steel base, general purpose bottom. By general purpose is meant a plow that will not only plow stubble, but also tame grass sods. The shape of this bottom is such that it scours in a great many varieties of soils. This bottom turns a furrow well over and leaves an even, well crowned furrow top. The types of soil in which this bottom gives the best satisfaction are the sandy and clay loam, and some waxy soils where scouring is a hard problem. This plow bottom is well adapted to heavy loam and gumbo soils,



This ground was plowed with a bottom like the one shown in illustration F. The characteristics of this bottom are plainly discernible in the plowed ground.

provided the ground is not wet, or does not disintegrate or slack when it comes in contact with air. Whenever plowing ground where the furrow slices do not hold together well this shaped bottom can be safely used. On account of the shape and gradual turn of the mould-board it does an exceptional job of pulverizing.

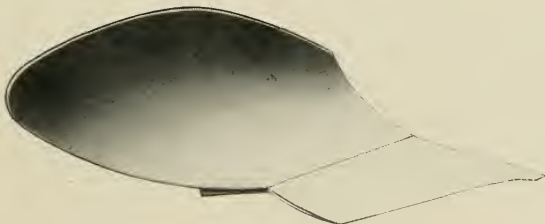

Illustration G

Illustration G is a long, slow turn bottom particularly adapted to stiff clay soils and all classes of soils that



Work of the plow bottom shown in illustration G. Observe that the ground is very finely pulverized and the few clods are flat. The surface of the ground is level; furrow crowning is imperceptible. The furrow bank is smooth, the bottom is well cleaned, leaving an ideal surface for the following bottom to lay the next furrow slice.

have clay in their composition. This bottom thoroughly pulverizes clay if the soil is in a condition to be plowed. The shape of this mouldboard is such as to cause the earth to separate in layers rather than to break into lumps. It is distinctly noticeable in a field plowed with this bottom that the few clods left are always flat shaped and very frequently will fall into pieces when picked up. Naturally, a bottom that does this kind of work requires more power than one which does not pulverize the ground as effectively.

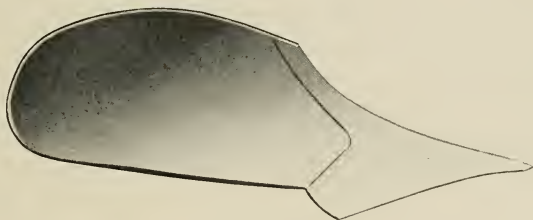

Illustration H

Illustration H is a general purpose bottom made specifically for work in all types of clay and sandy loam that are hard to penetrate. It is also the most desirable bottom for use in these same types of soil full of gravel, cobblestones and shale or flat stone. This bottom is made with a narrow breast which permits the



The work of the plow bottom as shown in illustration H. In view of the fact that it is necessary to aerate soils when they are being plowed a plow bottom to work in this type of soil must be designed to prevent stones from throwing it out of the ground the least number of times and when it is thrown out to penetrate quickly. This type of bottom does this work exceptionally well.

use of a strong and well tapered share required for stony lands, consequently this bottom will penetrate this kind of ground and thoroughly stir it which is necessary if the oxygen in the air is to mix freely in the ground. This kind of plowing cannot be accomplished in these soils with an ordinary bottom. The narrow breast and the high delivery mouldboard insure the earth being well mixed in the process of plowing.



Illustration I

Illustration I is a general purpose bottom. This bottom is made to plow the volcanic ash soils that are found



The work of the plow bottom shown in illustration I. Observe the deep furrow wall and the well turned furrow slices.

in the northwestern section of the United States. In plowing these peculiar types of soils the farmer frequently desires to plow deep. This can be accomplished with this bottom. The shape of the mouldboard is curved so as to pulverize this type of soil exceptionally well.

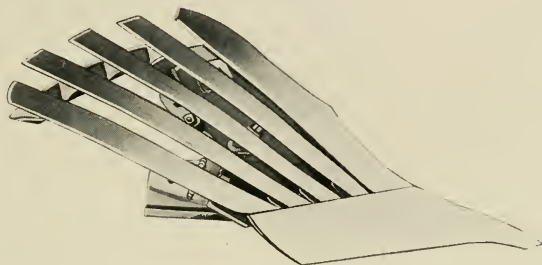

Illustration J

The slat mouldboard gives less surface, hence less earth sticks. For this reason the slat bottom serves a good purpose.

Illustration J shows a slat bottom. There are soils so sticky by nature that the ordinary plow bottom will not scour. These soils will not hold together sufficiently to give enough pressure against the mouldboard for scouring. The slat bottom eliminates a part of the mouldboard. Therefore, there is not so much surface to which the earth may stick. For this reason a slat bottom will scour and do a good job of plowing where a solid mouldboard entirely fails. These bottoms are also exceedingly useful for plowing black, waxy and clay soils in which an ordinary plow bottom fails to scour. The share is made with a comparatively straight edge to give a straighter cutting surface to the share.

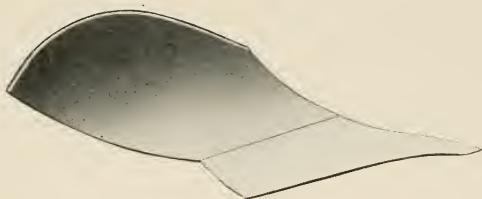

Illustration K

Illustration K is a stubble bottom designed for use in waxy soils and the lighter prairie soils where scouring troubles prevail. This bottom is particularly adapted to work in those soils that have a tendency to stick to the mouldboard, but are rather loose in their composition. For this reason the share and mouldboard are shaped to cause as little breaking of the soil as possible until it leaves the mouldboard. The furrow is turned



A type of soil in which the above illustrated mouldboard is in common use. A glance at this picture is sufficient to show that the plowmaker's problem is a difficult one.

slightly more than half over. On account of these features this bottom is not adapted to plowing sod. The unusually sharp point and narrow angle formed by the landside and share give this bottom great penetration,

a feature which is absolutely necessary in the types of soil to which this bottom is adapted. The shape of the share and mouldboard is such that the earth exerts an even pressure upon the bottom from the time the share strikes it until it is turned over on the furrow side.



Illustration L

Illustration L depicts a bottom popularly known as a Scotch type and is for use in turning soils in those countries where clay land predominates and where rainfall is excessive. The share is narrower than the mould-



The work of the plow bottom shown in illustration L reveals that the earth is turned over with little or no pulverizing. This is necessary for underdraining and to give the furrow slice on top an opportunity to dry out so that it can be successfully tilled.

board, consequently, a portion of the furrow is not cut entirely off. The mouldboard pushes the cut part of the furrow solidly against the preceding furrow, shaping the furrow to leave the top diamond shaped, and drainage facilities on the bottom.

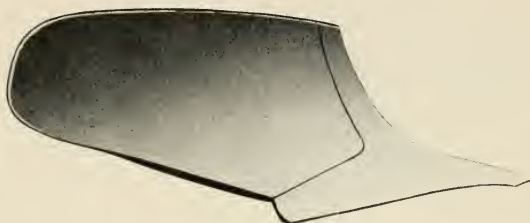

Illustration M

Illustration M shows a chilled bottom made for handling all kinds of gritty, sandy soils, and also clay lands that are not sticky. This bottom is made with a sloping landside. When the plow picks up the dirt to turn it over, the lower outside edge of the furrow slice acts as a fulcrum over which the furrow turns. When the furrow is raised into a position almost vertical the dirt falls of its own weight because there is nothing to prevent its downward motion. As the earth begins to fall it naturally crumbles, filling the lower portion of the furrow with loose pulverized soil. The advancing mouldboard finishes the work by turning the rest of the furrow on top.

This process of plowing is exceptionally good for sandy soils because it insures a thorough circulation of air in all parts of the furrow slice. Another advantage of the sloping landside is that the shin acts upon the earth very much in the same manner as a knife acts upon a piece of wood when operated with



Note the sloping landside and the thoroughly turned furrow slice. This work was done with the plow bottom shown in illustration M.

a slanting cut. This also has a tendency to make the plow pull lighter in draft than a plow with a straight landside.

These few illustrations serve to show that it is highly important to select a plow bottom for handling the soil the way it should be, and also that when any doubt exists to consult a plow expert before a radical change is made in bottoms.

Generally speaking, the type of plow bottom that does the best work pulls the hardest because the old law that so much energy is required to produce a given amount of work is applicable to plow bottoms. Less power is required to break a clod into three parts than into a million. The breaking of earth into finer particles is highly important if the proper seed bed is to be prepared.

Tests have been made which show that mouldboards curved to do the pulverizing require more energy or power than the bottoms which break the soil into clods. The four illustrations showing sectional views of plowing are the results of a test made purposely to determine whether the plow bottom that did the best pulverizing pulled heavier than the one that did the inferior grade of work. This test was made in a field of very heavy clay and sand not in a loamy combination. It had not rained for several weeks. All the tests were made in the morning of the same day in order that there should be as little change as possible in the moisture content of the ground. The only difference in the plow bottoms was in the shape of the mouldboards. Thus, the condition for all the plows was the same, the only different contributing factor being the mouldboard.



Figure 1

Note the thorough pulverization of the soil, the foot prints which show the dry condition, and the absence of air spaces.

Figure 1 shows a job of plowing almost ideal. One would not expect it in soil as dry and hard as this but the plow pulled 14% heavier than the plow bottom which did the poorest work, or that shown in Figure 4.

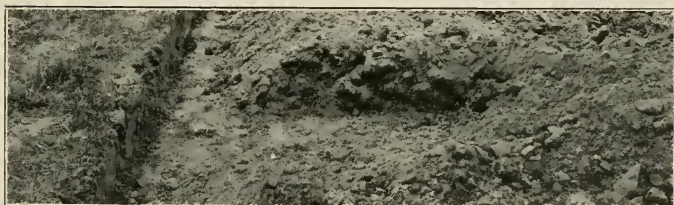

Figure 2

This plowing is not so well pulverized as that shown in Figure 1, but it could be regarded as a fairly good job of plowing dry soils.

The plowing shown in Figure 2 is not so good as that in Figure 1. The ground is not as finely pulverized. The plow bottom pulled 4% lighter.

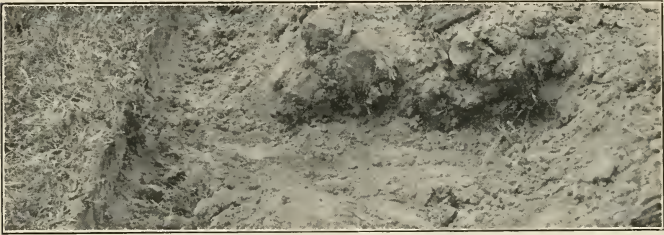

Figure 3

The clods are larger than those shown in either of the two previous illustrations. The air spaces at the bottom of the furrow slice are more pronounced, and the furrow slice shows cloddy formations rather than pulverization.

The work in Figure 3 shows that the earth was turned up into clods. There is little pulverization. The bottom used in doing this work pulled 13% lighter than the one that did the work shown in Figure 1.



Figure 4

Clods are larger than in Figure 3. The furrow slices are unevenly formed. They are merely larger clods intermingling with smaller ones and the finer soil particles. There is no indication of pulverization which is necessary for the proper aeration of the soil.

The plowing done in Figure 4 shows the ground broken into large clods, little or no pulverization and very imperfect furrow slices. This job required less power by 14% than the one shown in Figure 1.

When one considers that the pulverization of the soil is vitally necessary in by far the greatest number of cases he will pay less attention to the draft of the bottom and more to its adaptability. Sufficient power should be used to do the work well.

An experiment was made with the bottoms shown in illustrations F, G, K and M to determine just what effect different shaped mouldboards have upon the soil. This experiment was made in a field of clay soil thoroughly saturated with water. It was necessary to perform such an experiment with a soil that would hold together sufficiently to make observations. Wet clay is the best kind of soil for this purpose.

These four types of plow bottoms are for use, as the descriptions read, in widely varying soils. The illustrations of the work done by these bottoms in the soils for which they are adapted, when compared with these illustrations, must forcibly call attention to the importance of selecting a plow bottom adapted to the soil. These experiments were conducted in the morning of the same day in order that the moisture content should be as nearly uniform as possible.

These illustrations also show the relative work done by the share, mouldboard and landside in such a way as to call attention to the difficulty encountered in trying to establish a fixed center of draft that will serve as a guide for all shaped plow bottoms and soils.

While this question would be more properly discussed in the chapters on plow hitches, these illustrations are so pertinent that the reader's indulgence for this deviation from good sequence is asked.



The right-hand side of the furrow slice is laid on the furrow bottom in such a way that the forward travel of the mouldboard will give it a pinching, crushing motion to separate the soil particles.

In the seventh paragraph of this chapter the plow bottom is referred to as a three-sided wedge.

The mouldboard and upper part of the share form the curved wedge shape part which separates the soil particles while turning them over. For the sake of clearness in this discussion the work of the plow bottom is divided into three parts: first, the share, cutting the furrow sole; second, the shin, cutting the furrow wall; third, the mouldboard, lifting, stretching, turning and compacting the furrow slice into an inverted position.

The relative amount of work that the shin, the mouldboard and the share do is exceedingly hard to figure. It is very doubtful whether an absolute center of draft can

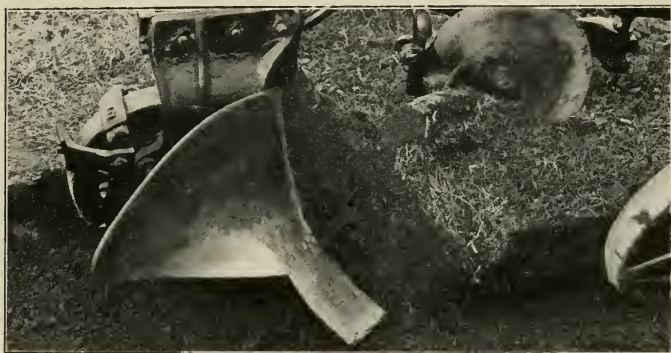

A section of the furrow shown in the illustration on page 116 cut farther forward, showing that the plow bottom has forced the furrow slice to conform to its shape, thereby beginning a stretching operation on the bottom of the furrow. Observe in the illustration on page 116 that after the furrow slice has reached the ground the freshly stretched furrow slice bottom is helping to put pressure against the top.

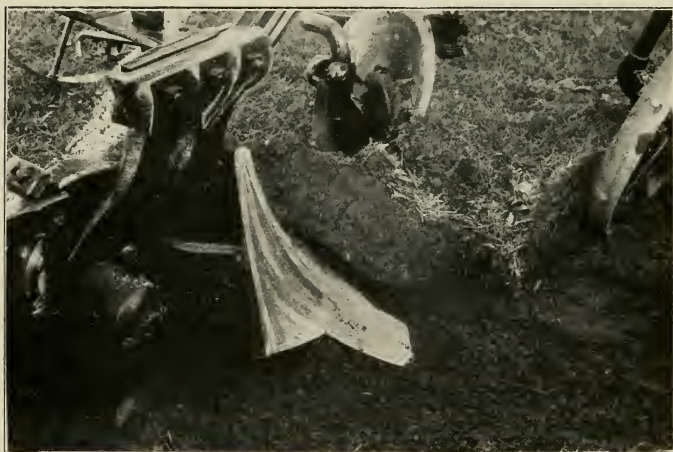

A plow bottom which does not have the proper shape to force the furrow slice against its surface so that the pressure is equal on all parts of the plow bottom. This illustration shows the importance of having a plow bottom adapted to the soil. The shin is doing the greater part of the work.



The work of this bottom shows remarkable adaptability to this type of soil. The squeezing, pinching motion of the mouldboard by forcing the furrow slice against the bottom of the furrow is plainly noticeable. This mouldboard is doing more work than the one illustrated on page 120.

be determined for all conditions. Enough experimenting has been done to show that the center of draft can be approached closely enough for practical purposes.

When once the center of draft has been determined it is obvious that the amount of work being done on all sides of this point must be equal in weight. Measuring the distance from this point to all the extremities of the mouldboard and share will give sufficient measurements to figure the percentages. The result will be close enough for all practical purposes.

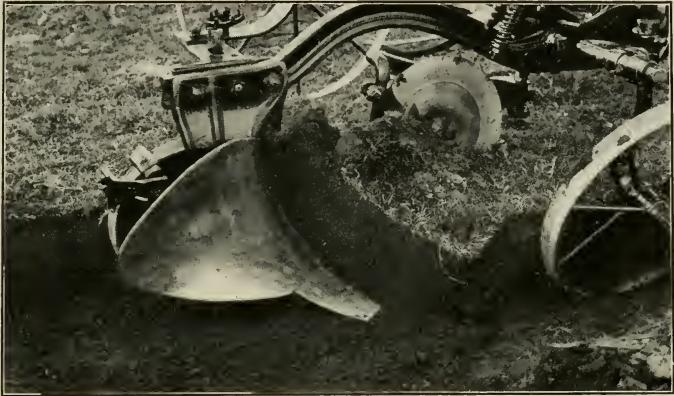

The furrow slice shown in the illustration on page 118 cut farther forward. The plow bottom forces the furrow slice against it in such a way that the complete furrow slice takes on the curvature of the mouldboard. This means a rearrangement of the soil particles from the top of the furrow slice to the bottom.

Another way for determining the relative draft of the share and mouldboard is to remove the mouldboard from the plow, then start the plow in a furrow the proper width and depth previously prepared with the end of the furrow slice cut squarely, and the furrow wall the depth of the furrow far enough ahead for the experiment. A dynamometer will show the relative lifting work done by the point and wing of the share. The plow must stop as soon as the earth has been lifted the height of the share.

Putting the mouldboard back on the plow, and lifting the furrow^o slice which has been measured the proper width and cut the full depth until it is ready to drop into position, will obviously determine the amount of work required by the share and mouldboard. Subtracting the difference between this amount and that required by

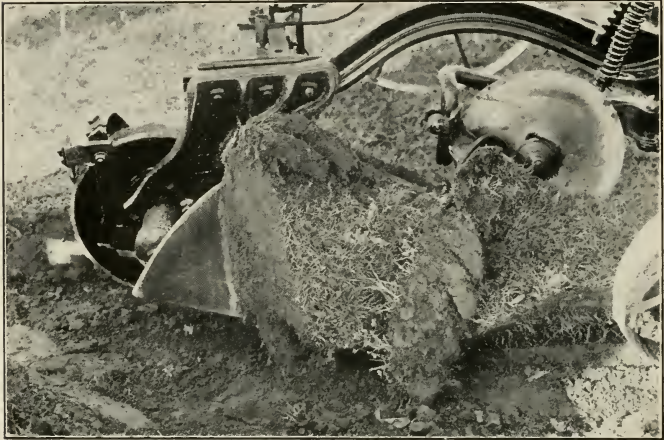

The furrow slice is being picked up and turned over very much as a cake of ice, without any perceptible pulverization of the ground. Observe that the bottom of the furrow slice does not rest against the furrow bottom except the loose particles that have broken off and have fallen down. Observe the center of draft on this plow is lower than the one shown on page 118.

the share will give the amount of work done by the mouldboard. Using the entire plow without cutting the furrow wall gives the amount of work required by the shin to cut the furrow wall, the share, the sole, and the mouldboard to crush and invert the furrow. Experiments of this kind have been conducted with widely diversified results.

A test was made using what is known as the Scotch type of plow bottom. The ground, clay sod, was being plowed six and one-half inches deep and eleven inches wide. The amount of work done by the share was forty per cent. of the total, the lifting and placing by the mouldboard, forty per cent. and cutting the furrow wall by the shin twenty per cent.

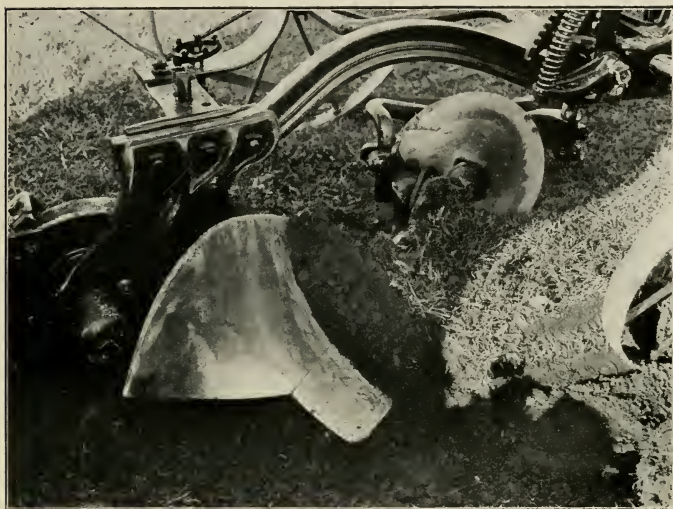

The furrow slice the same as shown on page 120 cut farther forward. This furrow shows no indication of pulverization but a tendency to lift the slice from the start.

Another experiment with an entirely different shaped bottom cutting six inches deep and fourteen inches wide revealed the following result. Thirty-three per cent. of the work was done by the share, forty-seven per cent. by the mouldboard, and twenty per cent. by the shin cutting the furrow wall. The type of soil in which the experiment was conducted was a clay loam sod.

In both instances the draft of the plow was arranged so that there was no pressure of the landside against the furrow wall.

The amount of work required of the landside is solely determined by the hitch. If the hitch is properly made there is little landside pressure because the land suck on



A type of mouldboard which breaks this wet clay soil into large clods. Notice the bluntness and the effect upon this soil. It ought not require any argument to show that this plow is not adapted to this type of soil. Breaking soil into clods is not plowing.

the share and shin cuts away the earth, leaving the landside free from coming in contact with the furrow wall. However, in actual practice this condition does not prevail.

It has been found that the pressure of the landside against the furrow bank caused by incorrect hitching increases the total draft of a plow bottom from fifteen to forty per cent., depending upon the kind of soil being plowed and the distance the hitch is away from the center line of draft.

This statement with reference to the pressure of the landside immediately suggests the point, why have a landside on a plow if there should be no pressure against the furrow bank? There must be some means for keeping the plow from swerving to one side whenever the share strikes some obstruction that causes a sudden shifting in the center of draft of the plow bottom. For



In view of the fact that breaking the soil particles is necessary for the proper making of the seed bed, the question often confronts those who have stony ground as to how they can plow so that the bottom will penetrate the ground immediately after the stone has been passed. The illustration shows how one farmer is accomplishing this work. On account of the rapidity with which this type of soil dries out it is highly important that there be the fewest possible unplowed stretches of ground.

example—if a plow should strike a snag on the wing of the share the center of draft of the plow is suddenly changed to a point near the wing. The landside pressing against the furrow wall holds the plow in its true



Turning an in-corner has been practiced by farmers who have soils that should not be trampled any more than is necessary in the process of plowing. It is highly important that the furrow be turned so that the ground is plowed properly if the best results are to be obtained from this practice.

line until the obstruction is passed and the center of weight returns to its normal position.

As a matter of fact, this condition is constantly taking place in the soil. The soil texture changes with every inch of travel and some means must be provided to take care of rapid and continuous changes. The shape and size of the landside have a great deal to do in this connection. Obviously there must be enough square inches



This clay field is being plowed seven inches deep to permit moisture to escape. This field was tilled but on account of the imperviousness of the clay excessive water remains and it is necessary to plow in such a way that there is under-drainage. Contrast this type of plowing with that shown in the illustration below.



When plowing sandy loam the great object is to stir the ground for aeration and leave it in such a manner that moisture will not unduly escape, thus the crowning of the furrows, noticeable in the illustration above, is entirely absent and the ground left as level as possible. These two illustrations are good evidences of the fact that plowmakers are striving to build bottoms that will do the soil the greatest possible good.

of landside surface to prevent the plow gouging into the furrow wall and also to help keep the plow running level. On breaking plows the shallow furrow requires an ex-



This method of laying the furrow when plowing sod insures the fewest possible air spaces and vents for the continued growth of the inverted grass blades.

ceptionally long and narrow landside to give the required surface. On stubble and general purpose plows this surface can be acquired by giving more height and not

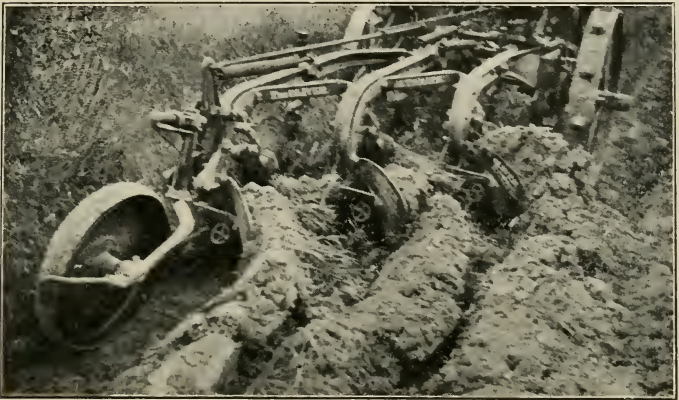

One does not often see three different styles of plow bottoms on the same plow. These bottoms are all cutting the same width and the same depth but notice the difference in the delivery of the soil. The front plow bottom is doing the quality of work this soil requires. The other two are not—the middle bottom doing better work than the rear one. The front bottom is the same as that shown in illustration G; the second, illustration F; the third, illustration K. Observe in the work of the front bottom that the soil is completely turned over and well pulverized and that the middle bottom turns the furrow over more completely than the rear one.

so much length. In bottoms that are made for deep plowing more attention is given to the height of the landside than to the length because of the greater amount of work being done by the mouldboard.

The amount of moisture in the ground, its looseness and compactness, and amount of stubble, trash, roots and sod are determining factors in the draft of plow bottoms. Too much moisture in the ground adds draft in the same manner as not enough moisture. Daily changes in moisture cause great changes in draft.

Shallow plowing of sods puts more work on the share and less on the mouldboard. Deep plowing of sod lessens the work of the share and puts more work on the mouldboard. The same is true of stubble.

The curvature of the upper part of the share, the mouldboard, and the angle of the mouldboard to the furrow slice have to do with the pulverizing qualities of the bottom as well as the draft.

The increase in the speed of a plow in dry, hard plowing aids materially in better pulverization, but while it is doing better work it increases the power required. A plow bottom shaped to do the proper work at a speed of two and one-half miles an hour will throw the dirt from two to three times as far when travelling at twice that rate of speed.

CHAPTER XIII

Plow Bottom Metals

THE farmer is often in doubt as to whether he should use a chilled or steel plow. A knowledge of chilled and steel metals as used in plows will enable a farmer to determine for himself which type of plow he needs.

In steel plows of the best grade, the principal wearing parts, the mouldboards and shares, are made from what is known as soft center steel. This steel is composed of three layers fused together. The two outside layers are very high carbon to insure hardness. An extra hard finish or temper is necessary to make the plow scour. The center layer is of low carbon to impart toughness to prevent the breaking of the brittle outside layers.

Steel plows thus made are successful for use in soils for which they are adapted. The mouldboard of a steel plow of the type described is only a quarter of an inch thick and the grinding and polishing necessary to finish the surface added to the natural wear, of course, wear away much of this thickness so that sometimes the soft center becomes exposed and the plow will no longer scour. For this there is no remedy and a new part is necessary.

While steel plows are, as a rule, lighter in weight than the chilled, when it comes to the matter of draft the chilled plow is by far the lightest in any or all soils for which it is adapted. The draft of a plow is determined not so much by the shape of its mouldboard and style of

share, as by the scouring qualities of the metal which enter into its construction.

As a matter of fact, tests in draft of plows have been made in the agricultural departments of universities. These tests have shown that chilled plows are lighter in draft.

No process has yet been invented whereby steel can be tempered hard enough to prevent sand and stones from deeply scratching the surface. Any farmer who has land that is sandy in places knows, if he uses a steel plow, that it refuses to scour after leaving the sandy parts and enters the black or sticky land. This is caused by the sand scratching the steel, leaving a feather edge that ruins the dirt polish and makes an obstruction to stop the shedding of the dirt.

Anyone who has never had this feature called to his attention can observe the phenomenon by examining his plow the next time he plows a piece of land in that condition. This peculiarity of steel makes a steel plow an exceedingly poor implement to use in any soil that has sand, gravel or stones in it, because the plow wears out too soon. It is like using a razor to sharpen lead pencils—too costly.

There is a type of land that steel plows turn to good advantage and much better than chilled plows can, in fact, where chilled plows will not work at all. Light soils, loams free from sand, gravel, or stones, and black, waxy dirt can be handled most successfully with the steel plows, because they have in them the properties necessary to make the dirt polish on the mouldboard without scratching it. Wherever this condition prevails, steel plows are the most successful, but when grit is present the wear on the thin layer of hard steel on the

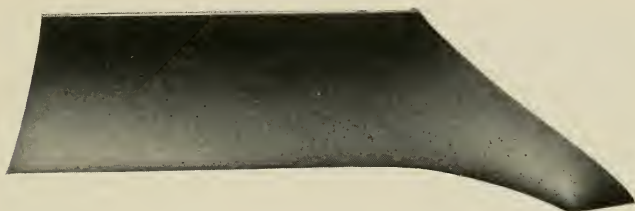

The top of a steel share is perfectly smooth and has as uniform hardness as it is possible to make.

Plow gunnels with and without a piece of steel welded on the bottom for reinforcing the point. This metal is of the proper carbon content to help keep the point from wearing upward on the bottom. It is illustrative of the efforts put forth by plow makers to make steel shares as durable as possible. The projection on the edge of the gunnel gives a wider welding surface thereby making the share stronger.

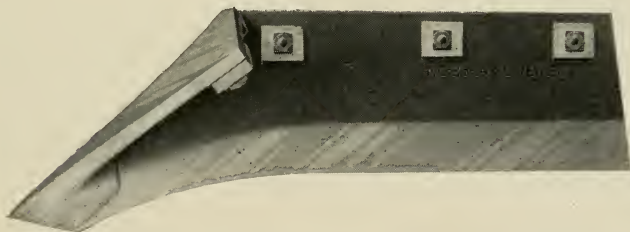
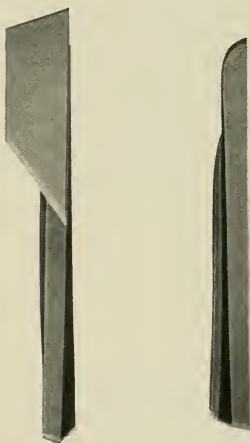

The bottom side of the share showing the position of the extra piece of steel on the finished product. This gives strength and additional wear.

surface soon exposes the center which is so soft that it will not scour in any soil.

Chilled plows are constructed by an entirely different process. When the mouldboard is properly made it has a flinty hardness that never has been duplicated in steel. This hardness enables a chilled mouldboard to much better withstand the scratching of sand, gravel, stones, etc. As a matter of fact, there is no scratching that will affect the scouring qualities of properly chilled metal.

As a result the more a chilled mouldboard is operated in sandy soil the smoother it becomes, and the higher polish it takes. Long experience has shown that used plows have a better polish than can possibly be put on in the factory. This peculiarity of chilled metal makes chilled plows scour better in all kinds of sandy, gravelly, stony, heavy clay soils, and the silt loams that contain silica, potash, lime, iron and aluminum oxide.

The chill, as plowmakers call the term of hardening, crystallizes the metal so that the grain is edgewise of the mouldboard instead of lengthwise. This means that the dirt in shedding passes over the ends of the crystals.

The ends of the metal crystals furnish the surface for scouring. For this reason chilled mouldboards are very hard to wear out. They often wear twenty years. Instances are known where they have worn fifty years. Chilled mouldboards have been used until the edge has been worn to the thinness of a piece of paper and sharp enough for a keen cut knife.

The thickness of a chilled mouldboard is about $\frac{3}{8}$ to $\frac{1}{2}$ of an inch. One-quarter of an inch of this entire thickness is made of chilled metal, consequently, a mouldboard will wear and scour until the entire thickness of the chilled portion is worn away. When this is



The shin and point of this bottom show the effect of sand upon steel bottoms. This sort of ground causes a steel bottom to wear out very quickly.

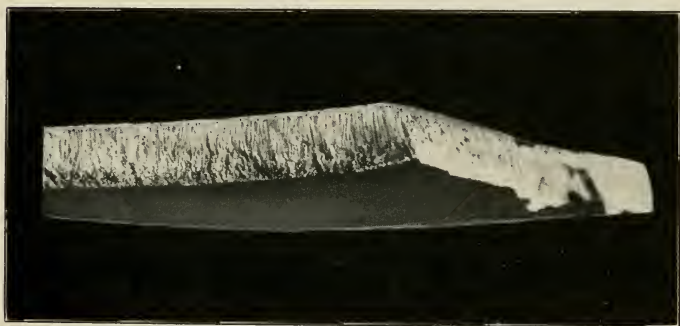

Chilled metal. This sample of chilled metal showing the crystals turned on edge explains why sand does not wear away chilled metal as it does steel. The dirt, passing across the ends of the crystals, has a tendency to polish chilled metal rather than to wear grooves in it.

compared with the thin layer of $\frac{3}{32}$ " of steel on the soft center steel mouldboard, one can readily see that a chilled mouldboard will outlast three steel. This fact is what gave rise to the statement that one chilled plow will outwear three steel in gritty conditions.

Properly chilled plows are not affected by rust. The iron being needle crystal in form merely corrodes on the end of the needle. The operator can scour a chilled plow that has been exposed to the deteriorating weather conditions for a long time in a few feet of travel with the bottom in the ground. This feature of chilled plows is in great contrast to steel plows which rust so easily that the rust occasioned by a few days' exposure often makes them hard to scour.

From the foregoing discussion on chilled and steel plow bottoms, it is obvious that many farmers can use both types of plows to good advantage, and where it is possible to interchange the steel wearing parts with chilled, the advantage is double because of the saving in expense.

Oftentimes it is necessary to plow in the summertime when the ground is hard and dry. The chilled share being much more resistant to the hard earth will enable a plowman to do better work by using chilled shares.

Experiments have been tried many times to determine the amount of wear of chilled and steel shares. We quote one experiment that was tried for this purpose and the result. A two-bottom tractor plow was equipped with a chilled and a steel share of the same size and type, one bottom being equipped with a steel share and the other with a chilled share. The ground in which the experiment was tried was a sandy soil, very hard, with

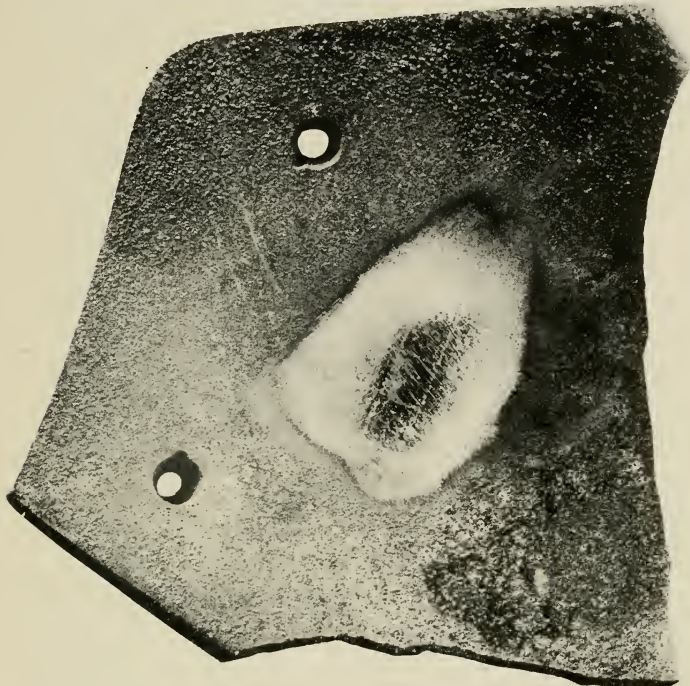

This piece of chilled metal was buried eight years. The rusty surface was scratched away with the back of a knife blade, revealing a perfectly smooth and unpitted surface beneath.



STEEL

The peculiarity of the way each metal wears is plainly discernible.



CHILLED

The points of these shares are illustrated on page 136.

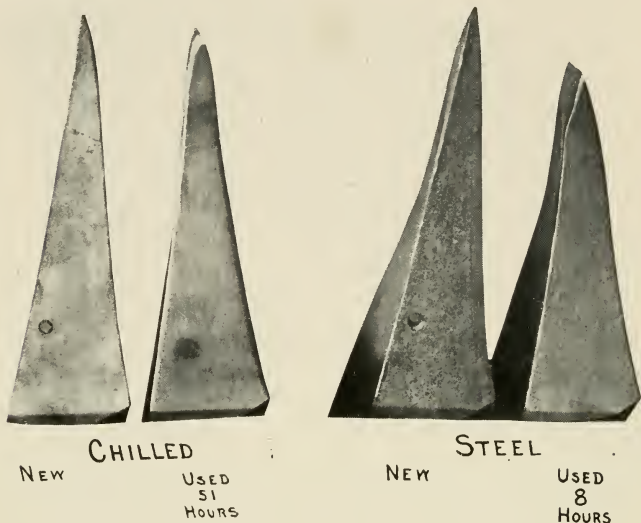

some stones in it. The test was made the first of September. The steel share was only used eight hours and the chilled share fifty-one hours, thus showing that the chilled share in this type of ground would outlast six steel shares.

CHAPTER XIV

Scouring Troubles

ANY man who has ever operated a plow knows what failure to scour means. A plow bottom must scour if the best work is to be done.

The reason why plows fail to scour is very seldom the same in any two fields, yet, underlying all these causes are five fundamental facts. The first and most common cause is the lack of an earth polish; the second, improper plow adjustment; third, soil conditions; fourth, soft spots or inequalities in the mouldboard; and fifth, the shape of the bottom with relation to the soil texture.

The easiest way to overcome the lack of an earth polish is to take the plow into hard ground and operate it until this polish appears. A new plow coming from the factory is always covered with varnish or lacquer. This should be removed before attempting to make the plow scour. In removing the varnish it is better to use some varnish remover preparation or strong lye solution. Never use a sharp, steel instrument because it is very apt to scratch the mouldboard. Whatever preparation is used none of it should be left on the plow bottom any longer than necessary to clean the bottom because a solution that is strong enough to quickly remove the lacquer will have a tendency to pit the surface if left on for any length of time. The safest rule is not to leave the bottom from the start to the finish of the cleaning.

When a plow mouldboard becomes pitted it must be polished to the depth of pitting before it will scour.

If plows have this high earth polish and fail to scour the trouble can nearly always be traced to soft spots in the mouldboard, or to the soil itself. Assuming that the mouldboard does not contain soft spots and the soil does not contain enough silicon to scratch the mouldboard, the trouble may be caused by the plow not running in a true line of draft, or the soil is too loose for the proper amount of pressure to cause the mouldboard to shed properly, or it may be a combination of all these causes.

Side draft causes the mouldboard to work out of its normal position, thus making unequal pressure of the earth on the mouldboard.

The remedy for this trouble is to adjust the hitch so that the plow bottom works in its normal manner. Whenever a plow fails to scour it is always advisable first to be sure that the plow is running correctly. If this does not remedy the trouble lowering the plow an inch or two will put more pressure against the mouldboard, thus forcing off the earth which may be clinging to the bottom. It may be necessary to operate at this extra depth long enough to put on a new polish. Often times lowering the bottoms and travelling a distance of fifteen to twenty feet will suffice.

Occasionally soils which scour readily have spots in them that cause the plow to stick. These spots are nearly always the result of a change in the soil texture. That is, the spots where the plow sticks are caused by the soil being looser. If the driver will watch these places very carefully he can frequently cause the plow to scour readily by increasing the speed when passing

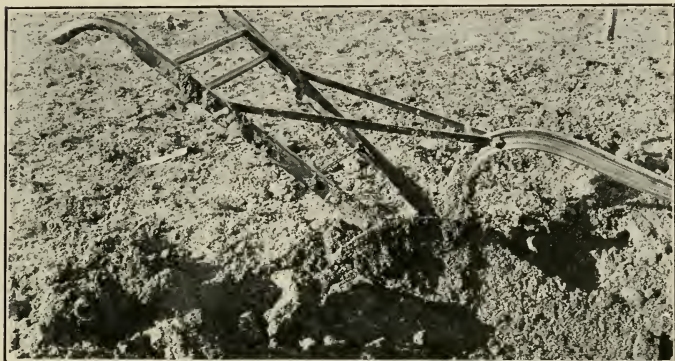

A type of soil in which mouldboard plows were never known to scour. Observe the soil sticking to the handle and the beam. This soil is of that type in which the soil particles have greater affinity for other substances. Plow mouldboards covered with plaster of Paris and hog hides have been known to turn this soil much more successfully than any metal.

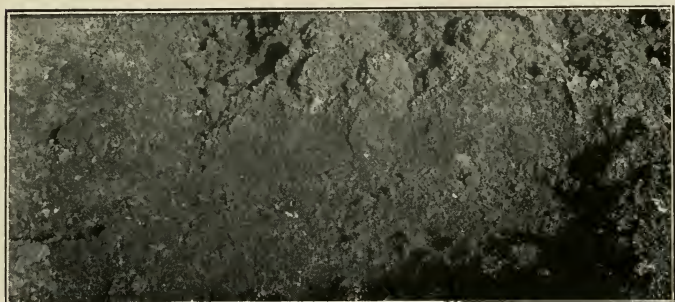

Sectional view of ground plowed in the above manner. The ground is merely pushed to one side and the top looks as though it might have been broken up with any kind of an implement. These soils offer the greatest opportunity for students who are interested in soil culture.

through, thus saving himself the necessity of cleaning the bottom with a paddle.

If none of these remedies effect a cure look very carefully at the mouldboard, particularly at the places

where the earth sticks. If the surface of the mouldboard has a cloudy appearing spot and is darker than the surrounding parts of the mouldboard, it shows that this part of the mouldboard is softer than the rest. The only remedy in a case of this kind is a new mouldboard.

If the surface has the appearance of being scratched and the earth sticks there is no known remedy for this trouble because a mouldboard plow has not yet been made that will successfully scour in this type of soil. The reason is that the soil is a mixture of very sharp sand and silt. The silt, being of a plastic nature, fills in the grooves made by the sand, thus destroying the high polish of the mouldboard and making it absolutely impossible for the plow to shed properly if the soil is moist enough to make the silt plastic.

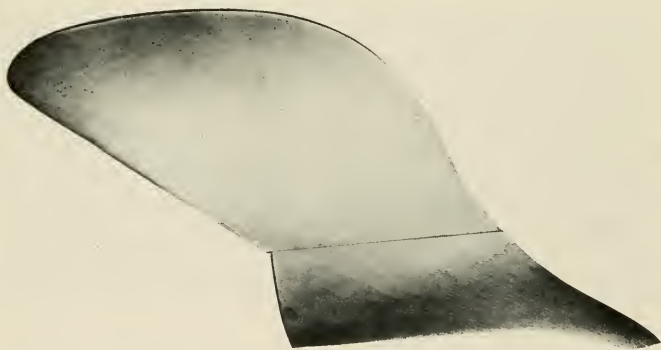

The scratched mouldboard cannot shed dirt properly whether it is of the variety that sticks to the metal or not. The two illustrations on page 141 show this bottom in sandy soil.

Another remedy that sometimes works to advantage is the moving of the coulter to the landside of the bottom. The object of this adjustment is to put an additional weight of the furrow slice upon the shin of

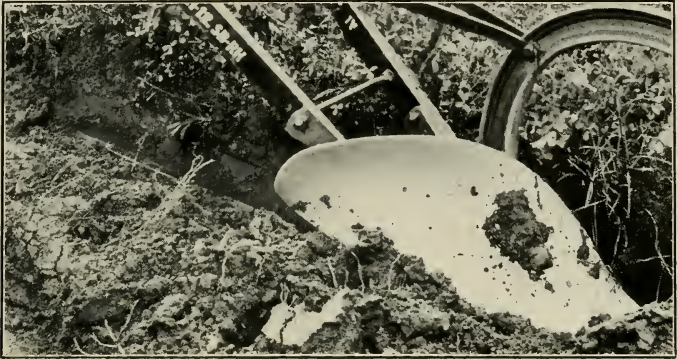

This bottom was used in a sandy soil growing alfalfa. The purpose was to find out whether a steel plow would shed this soil as successfully as a chilled plow. The illustrations on pages 142 and 143 show the chilled plow in the same field. The plow was drawn back in the furrow and no effort made to clean the earth from the mouldboard.



This illustration shows the above plow in alfalfa sod. Observe that it scours in one place and does not in another. This is characteristic of the steel plow in gritty soils. It puddles the sandy soil which is bad for aeration and helps to make it dry out quickly, paradoxical as it may seem.

the plow, thus causing greater pressure. Sometimes the coulters should be well forward, particularly when the soil is loose, because the action of the coulter picks up the fine, loose soil. The advanced position permits the earth to drop on the furrow slice sufficiently in advance of the plow bottom to prevent it from falling on the shin.

Oftentimes turning the plow bottom on its wing will start it to scour. This puts more pressure upon the mouldboard and is a very good thing to do when the trouble is caused by going from wet to dry soils or vice versa.

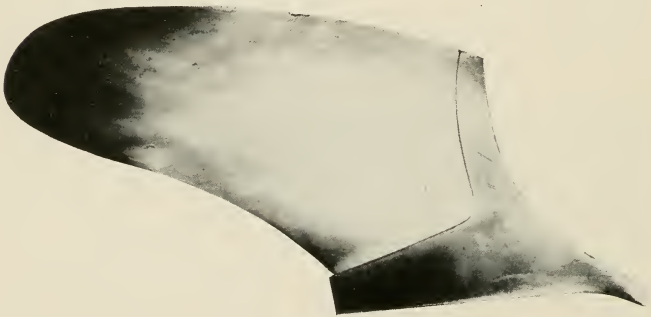

The chilled bottom photographed after the experiment illustrated on page 143. Observe there are no scratches on this mouldboard. The dark points on the wing of the share and end of the mouldboard show the high polish that the gritty soils put upon this bottom.

If it is noticeable, in all these different attempts to make the plow scour, that the earth is being turned over into clods and not pulverized properly, even though the plow does scour for a few feet, the wrong bottom is being used. The wise thing is to get in touch with some



The bottom pulled back from the soil in the same manner as the steel was. There is no earth sticking to the mouldboard nor is there any indication of puddling of the soil.

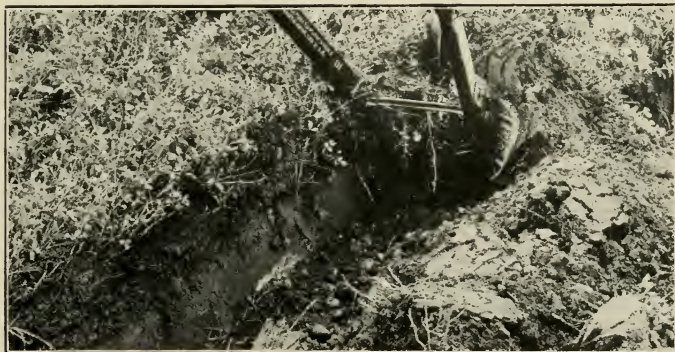

Observe the plow is scouring all the time and that the soil has the appearance of being pulverized and well turned even though growth of alfalfa was vigorous.

reputable plow manufacturer at once and have him send an expert to look over the situation. All plow bottoms are designed for the express purpose of inverting the earth. It is not possible to design any one type

of mould that will turn all the different soils equally well. The fact that clay soils hold together means that a plow to successfully turn and pulverize them must not have so bluff a mouldboard as is required for turning loose, sandy soils. The tendency of clay particles for holding together removes the necessity for as much bluntness and curvature in the mouldboard. As soils vary from one extreme to the other, so must builders make plow bottoms to meet these variations.

As a matter of fact, plow manufacturers have a large variety of plow bottom combinations in order to properly plow soils of different textures.

It is a peculiar fact that in the waxy soils of Texas, plow mouldboards have been made of steel, iron, glass, brass, aluminum, plaster of Paris, and hog hides. The peculiar part is that the plaster of Paris and hog hide mouldboards worked more successfully in these soils than any other type of mouldboard that has been invented.

Whether the shape of a mouldboard has everything to do with its scouring, assuming that it has the proper degree of hardness, is a question open to debate. The experiences gleaned from trying to develop a mouldboard that would work successfully in the waxy soils of Texas developed so many sizes, styles and shapes of plow bottoms that the plow bottom graveyard is full to overflowing. These experiences must be regarded as very strong evidence that something is required other than the shape of the mouldboard and the material from which it is made.



A never failing way to determine the soft spots in a mouldboard is to take an old file and break it so that a sharp edge results. Run this lightly over the mouldboard. The file will slide smoothly over the hard parts. It will stick to the soft spots. Plow manufacturers are always desirous of having their plows give satisfaction. After a little experience of this kind it will be easy to detect soft spots in mouldboards from their cloudy appearance. Soft spots never take the high polish that the rest of the board does.

The reason given for the success of the plaster of Paris board is that the plaster wears away with the earth. This demonstrates that the adhesive force between the earth and the plaster is greater than the cohesive force of the plaster. It also demonstrates that the cohesive force of the earth is greater than that of the plaster of Paris.

The plaster wears away rapidly and the farmer is obliged to recoat his mouldboard often—sometimes as often as every night. Considering that Texas farmers have different sizes and shapes of plow bottoms, it is plainly evident that the shape of the bottom does not control its scouring qualities. The revolving disk is the only type of steel plow at the present time that is regarded as handling this soil successfully, but the disk plow does not scour in these soils, showing that the adhesive force of the steel disk and the earth is greater than the cohesive force of the earth and also that the cohesive force between the two is greater than the adhesive force of the earth particles.

If it is a question of constant pressure of the soil against the mouldboard, it is necessary, then, in the design of a mouldboard to shape it to interfere as little as possible with the crumbling of sticky soils when turning them over.

It is far from easy to design a plow bottom that will always do these things satisfactorily. The Texas illustration must be regarded as conclusive evidence that the shape of the mouldboard is not the only factor to be taken into consideration. The material from which the mouldboard is made and the way it is made often have more to do with the success of the bottom than its shape. Very frequently a mouldboard that from all standpoints of theory should do a better job than another type of bottom does the poorer quality of work simply because the mouldboard fails to scour.

Another side in scouring that is little known and has received but spasmodic attention is the effect of heat upon metal mouldboards.

One time a plow bottom designer was trying out a bottom in sticky soil. The field was wet on one side and dry on the other. The day was fearfully hot. In the morning it was observed that the plow was scouring successfully in the wettest and driest portions of the field but where the two came together the plow refused to scour on going into the wet portion and also refused to scour on coming out. At noon the plow bottom was cleaned and left standing where the sun had a good opportunity to thoroughly heat it. The plow bottom became very warm and the first two rounds in the afternoon the plow scoured. After that the designer encountered the same trouble he had experienced in the morning.

It is a matter of plow history that a Texas farmer devised a pan arrangement back of the mouldboard, well down towards the share, to hold burning corncobs. The difficulty experienced in this device was the lack of uniform heat on all parts of the plow bottom. Those who witnessed the demonstration maintained that the mouldboard scoured where the temperature was hot enough, but failed to scour on other sections of the bottom.

There may be more in this theory than some of us think at the present time because it is a well known physical fact that heat is the best agent for separating molecules combined by adhesive force.

Oftentimes failure to scour cannot be attributed to any one cause. It may be a combination of two, three, or more of the conditions mentioned in the second paragraph. The operator must act in cases of scouring troubles very much like a physician diagnosing complications in a case of illness, and then apply the proper remedies for each trouble.

Enough has been said to show that a dull, or incorrectly shaped share can do irreparable damage, and the operator never discover the source of the trouble unless he takes time to investigate.

Incorrect hitching and a dull share combined cause a plow to do so many erratic things that the share symptom is often overlooked in seeking to rectify the trouble by hitch adjustments alone.

CHAPTER XV

Setting the Share on the Plow

KNOWING how to drive the team properly and make the hitch correctly are two points that determine good plowmanship. The other one is to know that your plow bottom is in the right condition. The share is the vital part in this work. If the operator is positive the share has the correct shape for land suck and penetration, he has little to worry about in making the plow work successfully. A plow bottom operating correctly cuts all the furrows the same width, the same depth, and runs level. If the plow is not doing this naturally, something is wrong. The first thing to investigate is the share.

If the bottom has a tendency to rise when the hitch is made where it always has been in the past for plowing that depth, the plow share is worn rounding on the under side, giving the share a sled runner effect. The tendency is to work out of the ground instead of into it. Sharpening the point is necessary to rectify this trouble.

If the furrow bottom is uneven and full of gouged places, the plow bottom is running on its point. If the hitch is the same as it has been in the past for plowing at this depth, the trouble is that the point of the share is bent downward too much, causing it to move forward with a jumping motion. This can only be rectified by putting a gradual slope on the point.

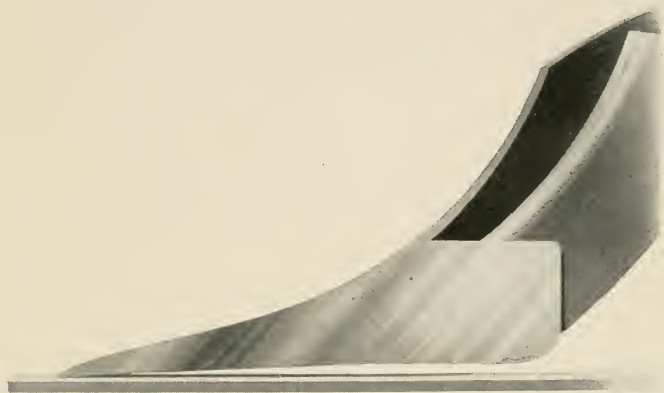

In shaping the point of a plow share the greatest care should be exercised to see that it has a gradual wedged shaped slant. One of the difficulties encountered when carelessly sharpening shares is to put the point of the share over the edge of the anvil, then hit it a blow with a hammer. The result is worse than the equivalent of a dull share. Instead of the plow going in deeper as intended, it gouges along the ground and increases the draft of the plow. The illustration shows the proper angle and shaping of the point.

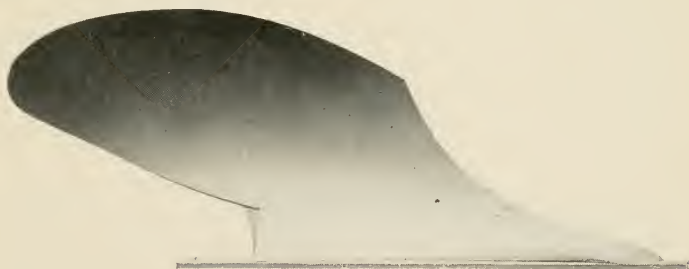

The wing of the share when properly sharpened, rests on a straight edge with the point. The edge of the throat is slightly raised from the straight edge. This means that when the plow is operating in the ground the point is as much low as the throat is high on the straight edge.

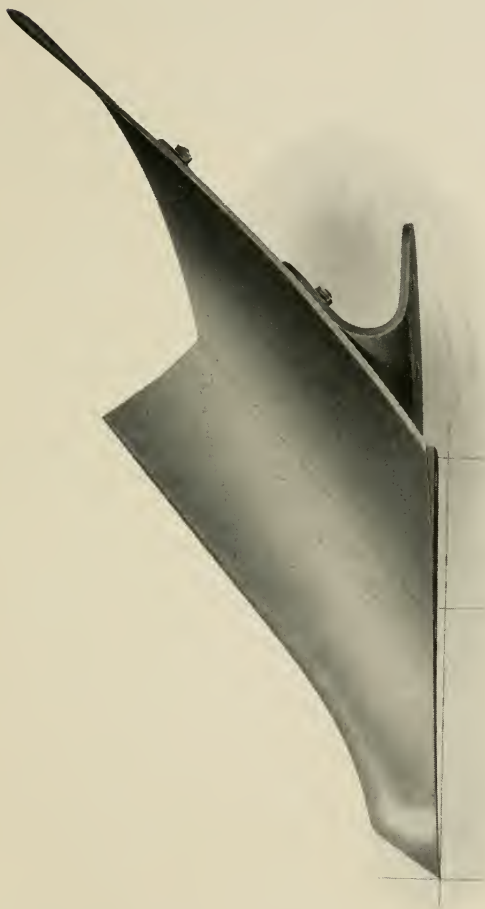

This picture illustrates the proper land suck for a plow share. The line parallel with the landside shows that the share begins to angle to the left, and terminates at the point in the line parallel with the landside. This is the proper method for sharpening a share because it gives land suck which is just as necessary as deep suck or penetration.

If the plow bottom has a tendency to pull down on the point so as to bear heavily on the land wheel and lightly on the furrow wheels, the share is bent upward too much on the wing. To remedy this the wing of the share must be lowered.

If the plow has a tendency to bear down heavily on the furrow wheels and not on the land wheel, there is too much dip or suck in the wing of the share. This must be rectified by raising the cutting edge of the wing.

The length of time that the bearings and axles of wheel plows wear, providing they are kept properly greased, is largely determined by the correct adjustment of the plow bottom. For this reason, as well as that of good plowing, plow shares should be kept sharp and adjusted correctly.

These are delicate operations and a competent smith or plowman should be consulted if the operator is not absolutely certain which course to pursue.

The share of a walking plow has more wing than the riding plow. This additional wing surface is necessary as a bearing to keep the plow running level. On sulky plows the wheels carry this weight. Hence, when the shares of wheel plows are properly sharpened, only the cutting edge comes in contact with the ground. The effect of the wrong set on a share is immediately noticeable in a walking plow and is identical with that of the wheel plows. The operator has to stand the brunt of the incorrect adjustment that the wheels and frame of wheel plows sustain.

When one remembers that the point of the share extends a slight distance landward from a line parallel with the landside to make it hold the land, and slightly downward below a line parallel with the bottom of the

landside to hold it in the ground, and the wing of the share with edge shaped to keep the bottom working level, he will have little difficulty in setting a share on the plow bottom.

Shares and bottoms made by different manufacturers have differences in shapes, but the general principle is the same.

CHAPTER XVI

Sharpening Soft Center Steel Shares

THE majority of steel shares are made of soft center steel, a term applied to the use of a layer of low carbon steel between two of high carbon. The soft center steel is by far the most common steel share in use and requires a particular treatment in sharpening because of the peculiarity of wear upon it. Most of the wear on the share takes place on the underside, hence the lower layer of high carbon steel wears away faster than the upper one. This must be observed very carefully in sharpening the share.

In heating, care should be taken that only the portion of the share which is to be pounded out is heated. This can be done by laying the share flat with the edge over the center of the fire and filling up the underside with green coals. This keeps the greater part of the share cool, thus preserving its shape. The common mistake is to put the share in the fire in a vertical position with the edge down. This heats too much of the share and causes it to warp and spring out of shape.

The pounding should be done from the upper side with the bottom of the share flat on the anvil. This keeps the cutting edge down and works the hard steel of the upper surface over the soft steel in the center, thus preserving for the share a hard cutting edge. Since shares receive the most wear on the under side, pounding the share on this side exposes the soft center steel and has a tendency to work the cutting edge out of shape.

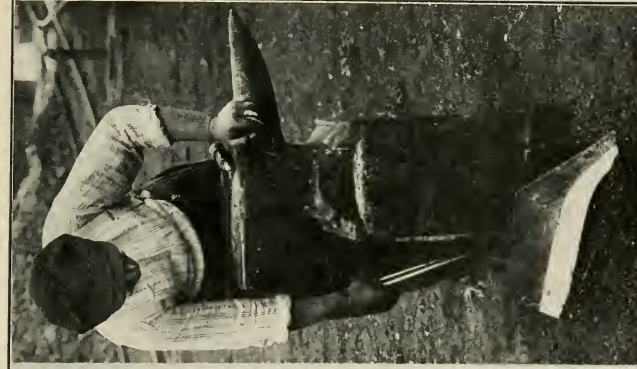
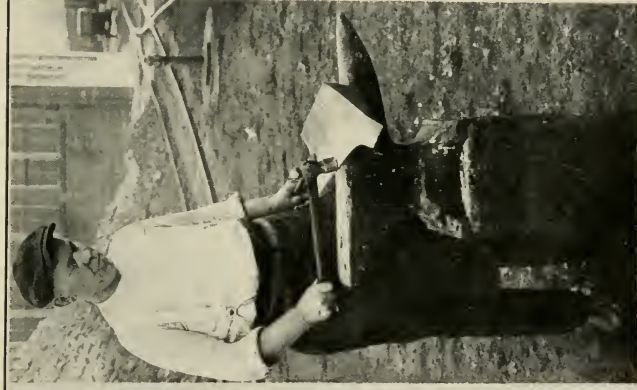
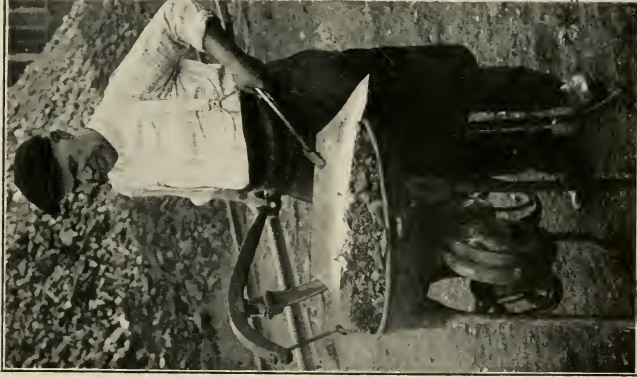

These three illustrations show the proper method for sharpening a soft center steel share and tempering it. Do not heat any more of the edge, at one time, than the operator has time to pound out before it cools.



A picture of a soft center steel share pounded on the upper side. The edge has the appearance of being somewhat rough but the hard steel was worked down over the edge. Sometimes in heating soft center steel shares the layers of steel are loosened. Wherever this happens pounding the share on the upper side keeps it from wearing away.

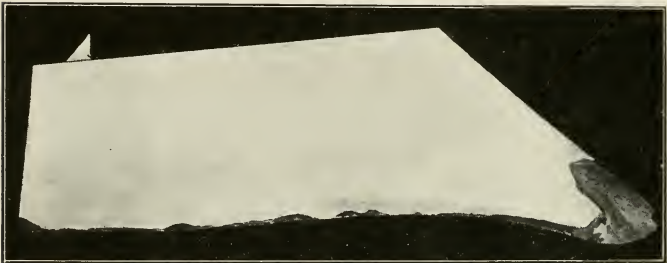

Soft center steel share pounded on the under side when being sharpened. Notice that the hard steel on the surface has been broken away on the edge and on the point. This is caused by improper heating when sharpening and pounding the share on the under side. A little practice in sharpening soft center steel shares in the correct way and an understanding of how to set them on the plow will eliminate a great deal of the difficulty farmers experience in the operation of the plow.

After the point has been hammered on the anvil to the proper shape, if necessary, a piece of steel can be welded to the top of the point.

Care should be taken in doing this work not to dent the share when hammering it out as this would spoil its scouring qualities.

To temper the share properly after it has been hammered out requires uniform heat. The right heat is a dull cherry red, a temperature of approximately 1472° F. One of the most successful methods of tempering is to slowly draw the share through the fire with the cutting edge down until the edge has been heated to the proper color. Then draw the share from the fire, put the point far enough into the ground to hold up the share, and let it stay there until it cools.

CHAPTER XVII

Sharpening Crucible Steel Shares

CRUCIBLE steel shares are made of one piece of steel. They cannot be tempered so hard as soft center steel because tempering makes them too brittle and thus subject to easy breakage.

Ground that sheds easily can be successfully plowed with a crucible share.

Crucible steel shares can be sharpened exactly the same as soft center steel shares, or they can be treated according to the old custom of pounding the share on the reverse side. However, there is less danger of misshaping the edge of the share if it is pounded on the upper side.

CHAPTER XVIII

Sharpening Chilled Shares

CHILLED shares are made in moulds the same as chilled mouldboards. On account of the nature of the iron they cannot be heated and drawn out by pounding as can steel shares. When it becomes necessary to sharpen chilled shares they must be ground on the upper side on an emery wheel or grindstone until a bevel edge appears.

CHAPTER XIX

The Rolling Coulter

THE purpose of the rolling coultter is to cut the stubble and trash into lengths the width of the furrow and leave a smooth furrow bank. On account of the great difference in soil texture and the varieties of trash different adjustments are necessary to bring about this result.

To make the furrow bank smooth the rolling coultter must be set to the land far enough away from the plow shin and deep enough in the ground to prevent the shin of the plow from digging into the furrow bank made by the rolling coultter. In ordinary conditions the coultter set to cut a furrow $\frac{1}{4}$ " to $\frac{3}{8}$ " wider than the plow bottom will suffice, but by no means can anyone assume that this is a set rule to follow. Set the coultter so that it accomplishes the result intended.

One must remember when setting a coultter to properly cut the furrow bank that, if the coultter, when set, is not running parallel with the landside of the plow, the plow is out of adjustment and the bottom must be correctly adjusted before the rolling coultter can be finally set. The depth at which the rolling coultter operates must be determined solely by conditions.

In cutting trash the coultter should make with the surface of the ground a condition similar to a shear cut, using the ground for one edge of the shear. In order to produce this shear cut with the rolling coultter it is necessary to have the coultter high enough to force

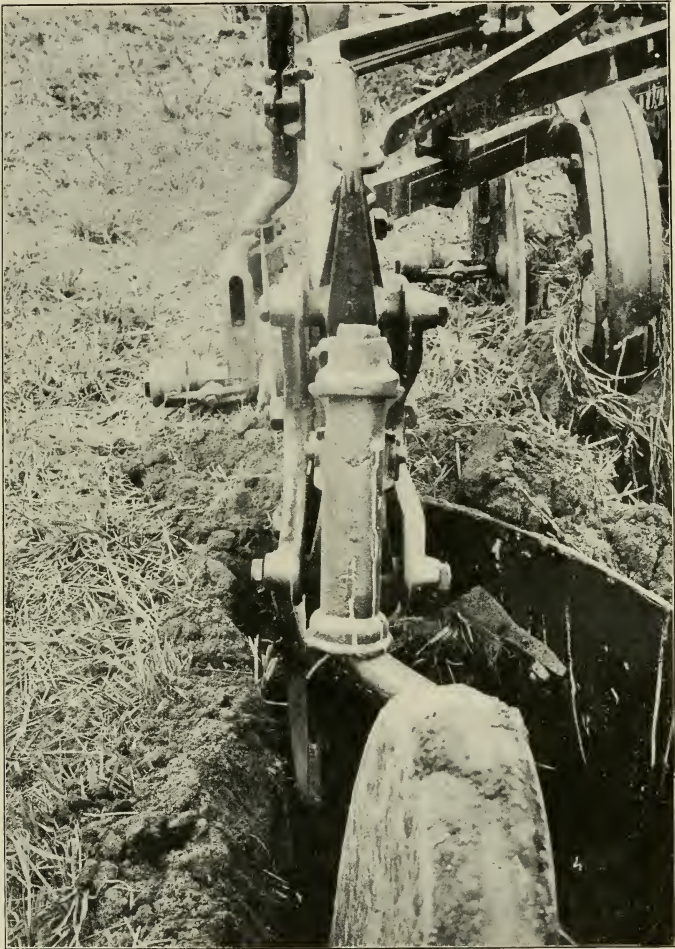

This illustration shows the effect of a plow out of adjustment on the rolling coulters. The rolling coulters is always pulled in a straight line of draft. The bottom as is illustrated by the landside shows that it is working out of its true line of draft. The clods and earth on the edge of the furrow bank are telltale evidences of the wrong plow adjustment.

the trash down and under. The coulter cannot do this if it is set deep enough in the ground for the downward motion at the cutting edge to be practically straight. For this reason the safest rule is to set the coulter deep enough to cut the trash without clogging and shallow enough to cut the trash without riding over part of it.

When operating the plow in hard ground the coulter set high and as far back as possible gives the plow point a chance to penetrate the ground first. The plow bottom sucks its way into the ground. The rolling coulter must be forced into the ground. If the coulter is placed ahead of the plow point part of the suction of the bottom will be utilized in pulling the coulter into the ground. If the plow point penetrates first it has the advantage of the weight caused by deeper penetration to hold the coulter in the ground.

In plowing stony ground the coulter set well ahead of the point and very low prevents stones from lodging between the coulter blade and the plow bottom.

A little study of these fundamentals will soon point the way for properly adjusting the coulter.

The Jointer

The purpose of the jointer is to turn a small furrow on top the furrow slice so that when this slice is inverted the trash, stubble, sod, etc., may be turned to the bottom of the furrow.

The adjustment of the jointer is very much simpler than that of the coulter. It should be set so that the furrow it turns should rest upon the larger furrow slice

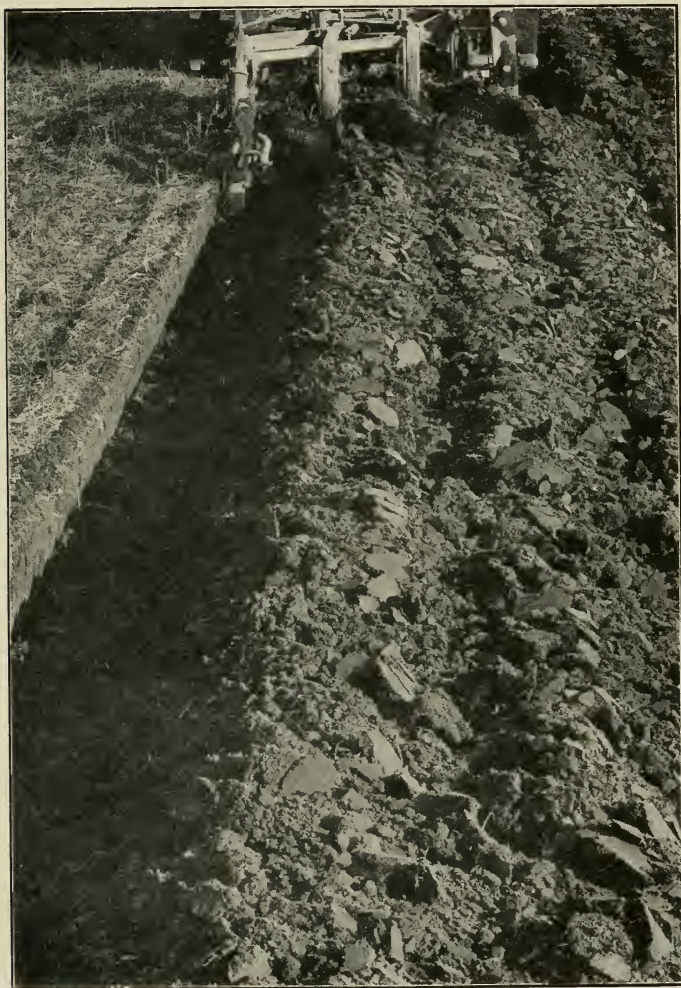

When the coulters is properly set the furrow wall is smooth with little or no dirt on the unplowed ground next to the furrow wall. The clean cut furrow slices and the absence of protruding stubble are the benefits of a correctly set combined rolling coulters and jointer.



Observe the jointer turning a little furrow into the right-hand corner of the big furrow bottom. This is necessary for ideal plowing.

in such a way that it will roll into the lower right hand corner of the furrow when the slice is being inverted. For the most part this point is slightly ahead of the point of the plow and on the unplowed land $\frac{1}{4}$ " to $\frac{3}{4}$ " from the shin of the plow. These measurements are by no means fixed. The adjustment must be made to bring about the desired results.

The jointer cannot be used by itself in very trashy ground because the trash will catch on the point of the shin and clog the throat of the plow. This fact led to the use of the combined rolling coultter and jointer, the adjustment of which is practically the same as that of the rolling coultter and jointer separately.

The Combined Rolling Coultter and Jointer

The combined rolling coultter and jointer is a recent improvement in plows and has made possible the successful covering of weeds and trash in the lower right

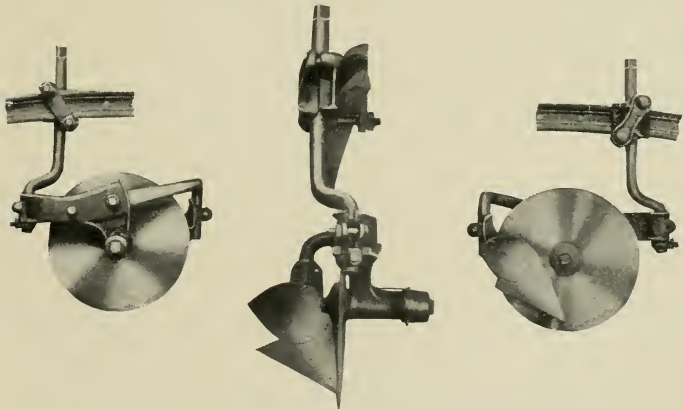

The combined rolling coultter and jointer is one of the greatest helps for plowing properly.

hand corner of the furrow where they interfere very little with the upward trend of moisture and thus rapidly help make humus out of the weeds.

The combined rolling coulter and jointer is the only attachment that has been invented for use with plows which absolutely assures that all kinds and sizes of trash will be buried deep enough in the ground for the successful eradication of insects which plowing puts out of business. Whatever time of the year it may be necessary for plowing it is always advisable to have that plow equipped with a combined rolling coulter and jointer and to see that all trash is buried on the bottom of the furrow.

CHAPTER XX

The Tractor Plow Hitch

BEFORE one attempts to adjust a plow he should know the physical laws that govern the operation of plows. Otherwise he is groping in the dark. It has been the experience of a great many plow experts that the principles or physical laws underlying the working of plows are not generally understood. For this reason this chapter will treat plow adjustments from the theoretical side (which after all controls the practical), rather than enter into a discussion of how the operator should change the hitch to produce certain results. Another reason for treating the matter from the physical law side is that specific instructions sometimes produce the opposite from the intended results. This happens quite often when instruction books are followed. No writer of instructions can call before his mind all the different conditions that must be met; consequently the best intentions cause trouble by the reader's inability to diagnose conditions correctly.

The draft laws that control the operation of tractor plows are the same for wheel and walking plows. However, different adjustments are necessary to make these different types of plows conform to the basic law governing proper adjustments. This law stated very specifically is: The shortest distance between two points is a straight line. In tractor plow adjustments one of these points is the "center of power" of the tractor, usually regarded as a point on the rear axle at equal distance

from the drivers. The other point is the "center of draft" (also called the center of weight or the center of resistance) of the plow. A straight line between these points is the "line of draft." The line between these two points is theoretically always straight.



Being obliged to turn the front tractor wheels toward the plowed ground indicates that the draft of the plow is pulling the front of the tractor in the opposite direction. This is hard on both the plow and the tractor.

The center of draft of the plow is an imaginary point in the plow base or bottom from which a single force pulling straight ahead and parallel to the furrow wall will cause the plow to work correctly with the minimum effort. This point is usually placed from 12 to 15 inches back from the share point, 2 inches up from the furrow sole and 3 inches from the furrow wall. One must remember that this point is not fixed but con-

stantly moves from side to side and up and down on account of the variations in shapes and the intensity of the pressure of the earth against the bottom. But for the sake of explaining the principle we will assume that this point is correct. In actual practice a slight variation does not materially affect the working of the plow.



Being obliged to turn the tractor in this direction shows that the draft of the plow has a tendency to pull the wheels toward the plowed ground. This puts enormous end-thrust on the front of the tractor, and demands additional power for operation.

It is impossible to pull a plow in the true line of draft because the hitch would be below the surface of the ground.

The fact that the power cannot be operated in a line parallel with the landside through the center of draft of the plow necessitates two lines of draft. These two

lines—one a vertical line of draft (or force) tending to pull the plow out of the ground and the other, the line of side draft, which has to do with keeping the plow operating straight ahead—determine plow adjustments. The line through which these forces neutralize (or the resultant force) is the true line of draft from a practical standpoint. All plow adjustments must be made to keep this line straight, because this line will straighten theoretically regardless of how the plow or the tractor operates.

When we understand these laws and what is necessary to keep the line between these two points straight, that is, between the center of power and the center of draft, we can readily see why it is necessary to have the plow beams and a vertical adjustment to take care of the penetration of the plow, as well as a horizontal adjustment to take care of the side draft.

In Fig. 5 is illustrated the vertical line of draft. C is the center of draft of weight. CX is the theoretical line of draft. B represents the center of power of the tractor. BGC then represent the line of draft passing through the clevis on the front of the beam of the plow at G. If the line BGC were angled as BHC and the resistance at point C required more power than the force necessary to straighten the line, it is evident that the line BHC would assume the position BGC before the plow would move. Hence the bottom would rise until BHC reached the position BGC.

Obviously this would lessen the depth of the plow regardless of the fact that there may be a wheel at the rear and one at the front. If the front wheel happened to be the controlling factor of a power lift, the lift would refuse to work because of the lack of weight to hold the

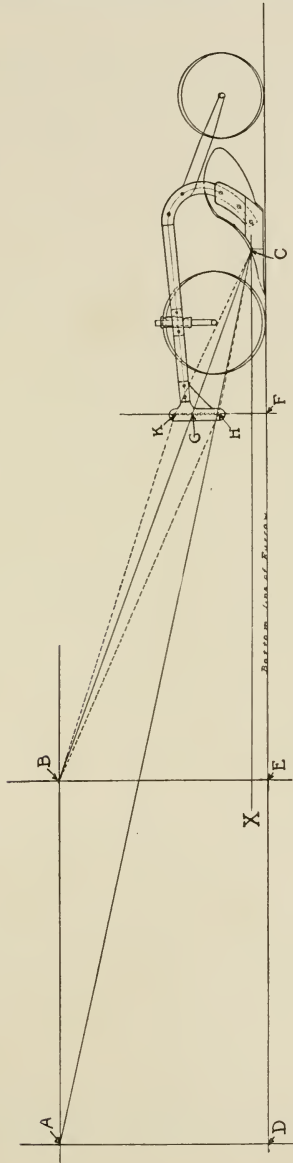

Figure 5 illustrates the vertical draft line of plows.

wheel on the ground. However, it is easy to imagine a hard plowing condition where the plow depth would remain the same and the effect show on the tractor. But remember that whatever happens to the plow or tractor, the draft line straightens.

Suppose the plow at point, C, requires 550 pounds effort to move ahead, and the tractor can only produce 525 pounds effort. In this case the plow would remain stationary and point, B, the center of power of the tractor, would lower until it reached the line AHC, providing no outside influence stopped it. If point, B, were back of the center of power the front wheels of the tractor would rise. If point, B, were ahead of the center of power undue weight would be brought to bear on the front trucks, and the rear wheels of the tractor would tend to slip because of the tendency to relieve them of weight. When this condition occurs, as it often does, the operator must adjust the hitch on both the plow and tractor until the draft line is straight.

It is further apparent that the height of the hitch on the tractor and the range of clevis adjustment on the front of the plow have everything to do with keeping this line straight when plowing at different depths.

Theoretically speaking, a different adjustment should be made on a vertical clevis every time the plow depth is to be changed, but from the way plows are designed, a slight variation in depth can be made without materially affecting the draft line. However, one should be very careful when adjusting the plow depth to vary it as little as possible if he expects his plow to operate perfectly.

Another feature of the vertical adjustment is shown in Fig. 5. The lines, AHC and BGC, show that the different

distances between the plow and the tractor necessitate different adjustments to plow the same depth. In other words, the farther the tractor is removed from the plow, the lower it is necessary to hitch in the vertical clevis if the operator desires to plow at the same depth as when the tractor is hitched to the plow at point B.

When the hitch on the tractor is exceedingly high it may become necessary to lengthen the hitch between the plow and the tractor to make the plow run at the depth the operator desires. This is another way of saying, keep the draft line straight.

The reader will permit a diversion at this point long enough to say that there is no truth in the theory that a short hitch makes possible lighter draft than a long hitch. The reason for this is very plain when we once understand that the minimum amount of draft required to pull a plow must be through a straight line from the center of draft or center of weight to the center of power. As long as the tractor and plow are in this relation the only difference is the weight of the additional length of the draft bar.

It is further apparent from Fig. 5, that if the hitch line is BKC and the force on the plow bottom is sufficient to draw line BKC into BGC, more power will be required to pull the plow because the front wheel will have to sustain the brunt of the downward pressure. This naturally will cause the plow to run on its point, making an uneven furrow bottom and interfering very materially with the pulverizing of the ground by the mouldboard. This is apt to throw the ground over into clods, breaking them rather than pulverizing.

If the plow has no front wheel, it is equally obvious that the bottom will go deeper in order to straighten the draft line.

If a wheel plow is working in ground that is hard to plow this trouble may not be noticed, but the instant it strikes easy ground the trouble will become plain immediately.

Another way for the operator to determine whether or not this point of draft is correct is to raise the front furrow wheel and also the landside wheel if they are both well to the front of the plow. The plow will immediately begin to penetrate deeper and deeper if the line of draft is not straight at the depth desired to plow.

If the plow is a gang, this condition will cause the front bottom to penetrate deeper than the rear bottoms. This naturally then requires lowering the hitch at K to the point G on the vertical clevis.

Side draft would not take place if the line of draft could be operated parallel to the furrow wall. The principle back of adjusting the side pull is identically the same as that of adjusting the vertical pull with the exception that it operates in a horizontal plane. If this be true, the question of why cannot this line of draft be operated at an angle as successfully as the vertical draft at once arises. The answer lies in the construction of the bottom. The suck and wing of the share are made to permit this vertical angle pull, while it is impossible to construct a device that will turn all the earth to one side and have enough resistance to keep the plow operating parallel to the furrow wall, particularly when the side pull has a tendency to draw the rear of the landside away from the furrow wall.



The last four furrows were turned with the plow out of adjustment. Notice the ground is broken and pushed to one side. Compare this with the rest of the plowed field with the plow in adjustment. This picture furnishes the best of evidence that a plow should be in the correct line of draft if the operator desires to do good work.

This fact brings up an interesting study of side draft, because the results of such adjustments seem to be contrary to what one would expect. The reason for this unexpected result lies in the fact that the draft bar attachment from a tractor to the plow is rigid on the plow and hinges to the tractor. Every man who has operated a horse plow knows that to make a right-hand plow take less land the horizontal hitch is moved to the left of the center line of draft, and if he desires to take more land he moves it to the right of the center of draft. He also knows that the pivot point is on the clevis of the plow and not on the shoulders of the horses which represent the center of power the same as the hitch on the tractor, hence there is an entire reversal of the order of hitch. One cannot expect to get the same results because there is a vast difference in the application of

power; although the law that the draft line will straighten itself is just as true.

A farmer can either separate his horses or bring them closer together to approach more nearly the straight line of draft. But the man who operates a tractor has not this advantage. In order to approach this line of draft, he must either run his tractor in the furrow close to the furrow wall, or else permit of side draft when plowing is difficult.

Everyone knows that it requires a certain amount of effort to produce a given result. Figuring energy and result as weight, we can readily see that it will require a given weight in energy to produce a given weight in result. Carrying this illustration a step farther we know that it requires one hundred pounds weight to balance one hundred pounds on a fulcrum between the weights an equal distance from each. Naturally then, if the greater weight is the tractor the result will show on the plow, but if the greater weight is the plow, the result will show on the tractor; and where the weight is more equally divided the result shows on both.

Since the pressure against the mouldboard varies very greatly in a given field, it should be apparent that when the tractor begins to swerve to one side the plow is in a hard condition of ground and naturally is exerting itself to straighten the draft line by pulling the rear end of the tractor around towards a point in the center draft line. On the other hand, if the tractor is running parallel to the plow wall and the plow is swerved to one side it is plainly evident that the plowing conditions are light. But in both instances the operator should know that he is not approaching the draft line, and that the plow and tractor are doing their utmost to observe this

law. The damage that is done to both the plow and tractor cannot be estimated, but it should be plainly evident that when the tractor is operating at its maximum capacity and the rear wheels are sliding toward the furrow wall and the front wheels pointing to the opposite direction on account of the operator trying to keep the plow cutting full width, there must be immense torsional stress on the tractor and tremendous end thrust on both the front and rear axles that cause the tractor to work harder than when the tractor is pulling in a straight line of draft. As a matter of fact, experiments have been made which show an increase of power required from 15 to 25 per cent. to say nothing of the damage done to the plow when the tractor produces enough power to spring the plow out of shape.

Fig. 6 illustrates for all practical purposes a perfect line of draft through the center of the plow and the center of power on the tractor. The slight distance the tractor is off center will not affect the working of the plow. When the plow and tractor are adjusted to this position the energy of the tractor is directed towards pulling the plow straight ahead. There is no side force of any kind to be overcome in the operation of the plow. Naturally, the minimum power will be required to pull the plow. The plow will do a perfect job. Neither plow nor tractor will be subjected to side stress which causes unnecessary wear, and oftentimes sudden breakage.

When it is necessary to hitch to one side the tractor has to exert power enough to overcome the forces which operate against this line when it deviates from the center line of draft. This can easily be seen by Fig. 7. C is the center of weight of the plow. A is the center of

power. AC then represents the line of draft which is angular to EC, the force which should act to pull the plow forward in the perfect line of draft, if the operator desires to plow properly.

According to the laws of physics, AB and AE constitute a parallelogram of force, hence the magnitude of the forces AB and AE is proportional to their length. In this diagram the proportion is 14 to 4.

Assuming it requires 540 pounds to operate the plow, this means then that 420 pounds are required to pull the plow straight ahead and 120 pounds to overcome the side draft. It is perfectly plain then that the tractor which is hitched to one side of the center line of draft in this case is required to withstand a torsional stress of 120 pounds. It is also apparent that as the line BC is placed closer to EA the proportion of forces becomes more evenly divided.

For example, if the hitch between the tractor and plow were shortened so that ABCE would form a square, then force AE would be equal to force AB; that is, the side draft would be increased to one half of 540 pounds. In actual practice with such a hitch as this it would require more than 540 pounds to pull the plow, because the tractor would be operating at a tremendous disadvantage on account of the additional force tending to pull the rear wheels of the tractor toward the line of draft (which as has been explained previously in this chapter will always straighten itself regardless of what forces may be acting against it). Hence, it is evident that the hitch on the tractor must be in a straight line from the center of weight to the center of hitch on the tractor if the minimum of power is required to pull the plow.

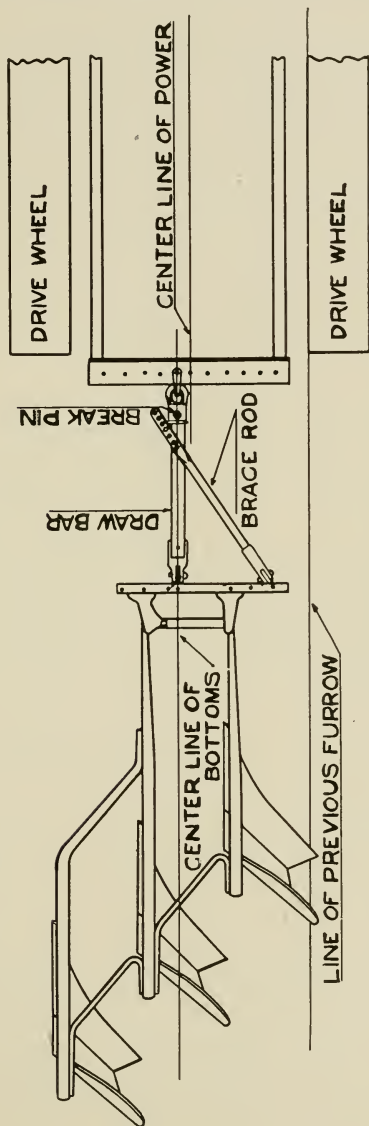

Figure 6. A diagram showing a tractor and plow in a practical center line of draft.

The question at once arises as to why the plow will not swerve around so that the line AFC takes the position AC as one would naturally expect it to do if the draft line is to straighten. The reason for this lies in the draft rod brace GH which is solidly fastened to the draft bar of the plow and the frame in front making a rigid connection on the plow, thus bringing into play another force which places the swivel point of hitch on the tractor instead of on the plow. Naturally when the tractor wheels begin to move towards the furrow wall the front of the plow must move in the same direction.

Both the rear of the tractor and the front of the plow would continue to move in this direction until the opposing forces would neutralize each other, but both the plow and tractor would be sadly out of shape.

Another observation from such a condition is that the draft bar I, pulls on the plow and the draft bar brace, GH, pushes, thus we have the two opposing forces, one pulling ahead as it should and the other pushing back as it should not.

It is plainly evident that undue stress is placed upon all parts of the plow and that the brace, K, is utilized not only to hold the plow beams the proper distance apart, but is pushing the front beam and the parts attached forward to offset the back pressure caused by the draft bar brace, GH.

It is further apparent from Fig. 7, that the farther ahead the tractor is hitched, the less will be the angle of side pull. Then it follows that the only possible way to lessen side draft when conditions will not warrant putting the tractor into the true line of draft is to lengthen the hitch between the plow and the tractor.

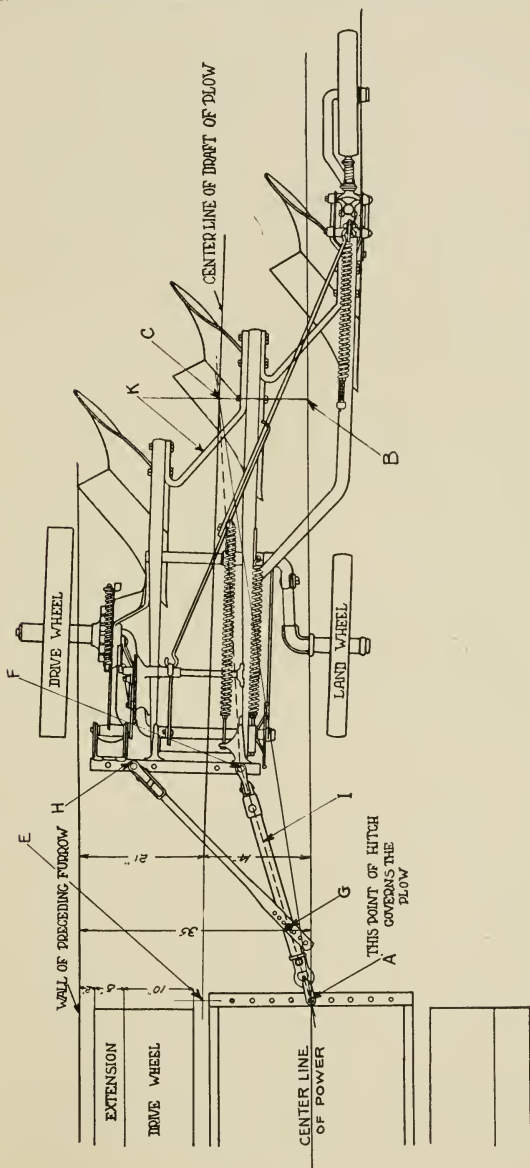

Figure 7. A diagram showing the principle of the horizontal draft of tractor plows.

This discussion, of course, assumes that the plow is in perfect working condition. Before one attempts to make adjustments he must know that the plow will respond or his efforts will be futile. Always see that the shares are sharp, with proper suck and wing, all the bottoms are scouring, bolts are tight, and levers working easily before attempting to make final hitch adjustments.

CHAPTER XXI

Adjusting Horse Plows

A WALKING plow is the simplest form of plows. It does the best of work when properly hitched and causes the operator the utmost grief if the draft line between the horses and the plow is incorrect.

The law that applies to the draft of tractor plows is the same for walking plows, but the application is radically different because the center of power upon horse drawn plows is the point equal in height to the average point on the shoulders where the tugs are fastened to the hames and midway between the outside horses. The draft line between the center of draft of the plow and this point will always straighten. The center of draft of either a walking or wheel plow is exactly the same as that on the tractor plow discussed in the third paragraph in the chapter "The Tractor Plow Hitch."

Because this draft line straightens, the depth adjustments can be made with the clevis on the front beam. Whenever it is desired to cut deeper the clevis is raised and when it is desired to plow shallow the clevis is always lowered. If it is desired on a right-hand plow to take more land the clevis is placed to the right, and to the left to take less land. Of course, these two adjustments are opposite if a left-hand plow is being used.

All these adjustments are made to keep that draft line straight at the depth and width desired to plow.

The walking plow is a very good example of the fact that an implement does not require a pole to make neck-weight.

The reason why sore shoulders, back, and hips are prevalent when using a plow with or without a pole is because the traces are not in a straight line from the point where the tugs fasten to the hames on the shoulders through to the center of draft on the plow. When a horse has a sore neck on top one raises the tugs at the back band. This is evidence enough that plowmen practice this principle whether they know it or not. The further fact that raising a tug at the back band often makes the back sore is positive proof that we are playing around the straight line of draft. How much better it would be after the plow has been adjusted to the depth one desires to plow to see that the hip straps are loose and that there is no downward pull on the back band, no upward pull on the belly band, no choking at the collar and no bearing down on top the neck.

It is necessary in walking plows more than wheel plows to have the shares absolutely correct before any kind of adjustments can be made. Where the weight of the bottoms is carried on wheels, the work of an incorrectly shaped share does not show up in a wheel plow so quickly as in a walking plow. For this reason if the operator makes all the adjustments in the clevis that can be made and the plow does not respond to the adjustments it is plainly evident that something is wrong with the share or some part of the plow is sprung out of shape. It is reasonable to assume that by far the greatest number of times this trouble will be in the share. It is necessary to have a thorough understanding of the setting of a share on a walking plow before one knows

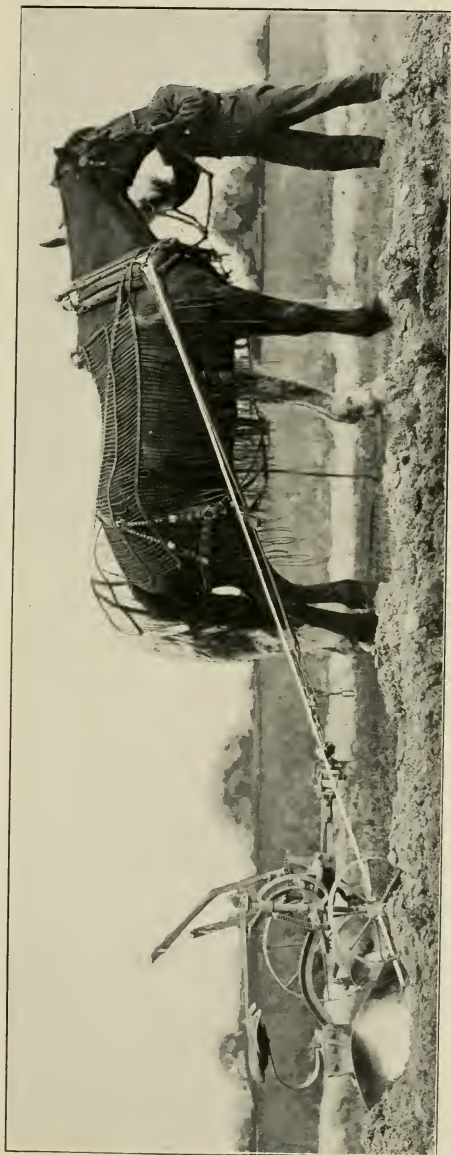

When the hitch is arranged so that the tugs are parallel to the line drawn from the center of the plow to the hames through the clevis pin it is correct. The furrow horse was removed to show that the hitch is correct. This line of draft should be the same in walking plows as it is in wheel plows, otherwise sore hips, necks, shoulders or backs are the result.



When hitching two horses to a sulky plow it is better to spread them apart. It gives the advantage of having fresh air circulating around them so that they can work to good advantage as well as to give the plow the advantage of working in the true line of draft. A thorough understanding of the draft line of plows will save a great deal of plowing trouble which is unnecessary.

whether he can adjust the plow as he desires it to run. The setting of the share is discussed in Chapter XV.

When two horses are hitched abreast the effect is equivalent to hitching two forces, one on each side of this theoretical center line of draft. That is, an equal force is operating on each side of the center of weight of the plow. These horses must be hitched so that the leverage is the same for both, otherwise one of the horses will be doing the greater amount of work. The closer one adheres to this theory the more necessary it becomes to regulate the width of singletrees and doubletrees in accordance with the size of the teams.

Every few years plow manufacturers change the angle of the beam in relation to the furrow simply because of the lack of knowledge of this one fundamental part in hitching to walking plows.

If a walking plow cuts 14" the point where the double-tree is attached to the plow must be immediately in front of the landside, which is 21" to the center of the previous furrow. This would make a doubletree with the two outside holes 42" apart.

To pull the plow straight forward the efforts of the two horses combined must make a straight line parallel with the furrow wall the width the plow bottom is cutting. If the clevis pin is too far to the right of this imaginary line the plow bottom of a right-hand plow will immediately begin to move to the left until this line is straight. This is the reason why the plow takes more land.

Obviously if the clevis pin is hitched too far to the left of this center the plow will take less land.

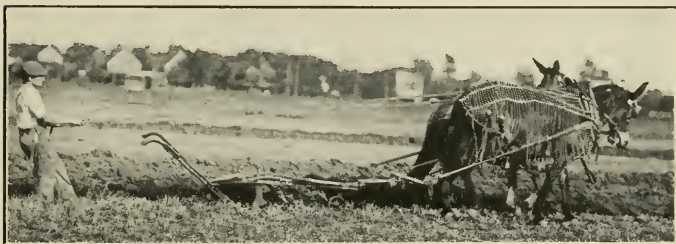

When a walking plow is properly adjusted it can be operated without the operator holding to the handles. The test of a man's ability to adjust a walking plow and sharpen the share is to make that plow operate correctly without holding the handles.

If the horses are hitched tandem a somewhat different result takes place. That is, the center of power is an imaginary point half-way between the tug staples on the hames of the front team and the rear team. This requires a different adjustment on the clevis of the plow if the same depth of plowing is desired. When three horses are hitched abreast it is obvious, on account of the size of the horses and the narrow furrow being turned, that the center of hitch cannot apply to the center of draft of the plow. It must be moved to the left of the clevis in order to give the horses an opportunity to work.

CHAPTER XXII

Middle Breakers

STRANGE as it may seem, the middle breaker is extremely useful for very wet and very dry ground. In wet ground the ridges made by the middle breaker dry out, giving the air an opportunity to mingle with the moisture in the ground in the right proportion for plant food development. Oftentimes the water level in the ground is close enough to the surface to keep a seed bed unduly wet. These ridges give the air and heat from the sun a chance to dry out the ground rapidly enough to develop plant food for the growing plants.

The lister is used most extensively in those regions where the soil is light and sandy and the evaporation of moisture is excessive, and in those parts of the country where the plowing season is short.

Listing prevents the soil from blowing and enables the crop to withstand the drought of the semi-arid climates. The roots work deeper into the soil, the surface of which is exceedingly warm. This places them in contact with more moisture.

Larger acreages can be handled when put in with a lister because of the elimination of a great part of the labor of seed bed preparation. The lister prepares the ground at one operation, taking the place of plowing, disking, harrowing, and packing. This is a great incentive to the use of the lister.

The lister is useful in a climate which is exceedingly wet early in the spring and dry during the growing season. The use of the lister eliminates much early spring plowing, but permits the farmer to get onto the field and plant a considerable acreage without any previous soil preparation.

Farmers in those localities where there is deficiency in moisture are forced to farm more acres to grow the same amount of crop. In other words, they must secure their rainfall by spreading out since they cannot depend upon a great depth of precipitation. Here listing as a labor saver is a very material consideration.

Listing is practiced in two ways. In some sections it is the sole method for putting in corn and in other regions it supplements checking and drilling. The farmer does what early spring plowing he finds to do since fall plowing for corn is not generally followed in those sections. When the rainfall is excessive in the planting season it often happens that only a small part of the proposed acreage of corn has been prepared for planting. In such cases the general practice is to list the wheat stubble and corn land with a two-row lister completing planting in a very short time. While listing is not adapted to a wet growing season, it is very useful when the early spring is exceedingly wet and the summer dry.

In communities where listing is practiced there is always more or less discussion in regard to the effect listing has upon the seed bed. The objection is often heard that listing leaves hard ridges throughout the field which subsequently become baked and leave the soil in bad texture. This is true when listing on clay and clay loam soils. On light, sandy soils this objection is not a serious one.

A twenty years' observation of fields which have been listed every other year shows that those soils which are adapted to the practice are exceedingly mellow and no bad effects have been found in the ridging of the soil. Here the practice has been to list at right angles to the last listing.

Another objection to listing often raised is that if the season is wet the soil in the furrow will bake and crust over so that the corn cannot break through. Here the

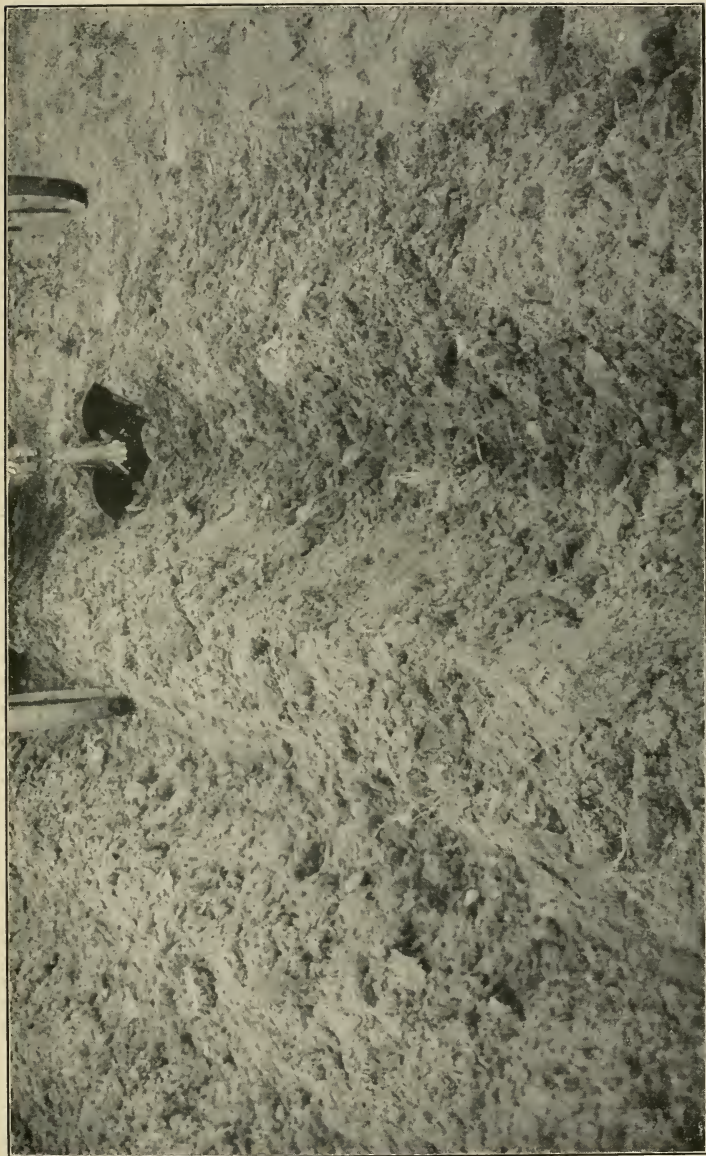

Using a middle breaker for breaking the soil. This treatment breaks up the soil twice as rapidly as can be done with the plow, thereby enabling the farmer to cover greater territory. This treatment helps to conserve moisture and keeps the wind from blowing away the soil.

objection is unfounded where listing has been practiced on the kind of soil for which it is intended. Baking so that the corn cannot break through has not been observed in the light sandy soils. There have been some very sad experiences with listing on heavy packing soil.

When the field has been listed and properly tended so that the last cultivation levels the ridges it has practically the same kind of surface as checked corn. Therefore the customary rotation of small grain and corn can be practiced to advantage. The prevalent method of putting in the small grain crop is to disk the field which was previously in corn in the early spring. Where the cultivating has been properly done and the ridges entirely leveled no difficulty is encountered in seeding the spring grain in the cornstalk field.

To be brief, the advantages of listing are as follows:

1. The prevention from blowing of light soils due to the ridges of the field.
2. The saving of moisture and the use of more sub-soil moisture by putting the roots deeper into the ground.
3. The saving of labor in the early spring.
4. Permitting a larger acreage than would otherwise be possible since it supplements planting in ridges where moisture conditions are difficult.

The middle breaker or "lister" is a combination of a right-hand and a left-hand plow bottom without the landside, the object being to throw the dirt to turn a furrow slice in both directions. This construction permits one mouldboard to act as a landside to the other, however, in the uses to which the middle breaker is put there is often greater pressure against one of the mouldboards than the other. This would naturally cause the entire bottom to swerve towards the side of least resistance until the pressure against each mouldboard would be equalized. To offset this a steel rudder is placed midway between the two bottoms to penetrate into the ground to keep the bottom operating in a true line of draft when these unequal conditions are encountered.



Breaking out the center edge with a middle breaker. This operation is necessary to make a good seed bed for any grain crop.

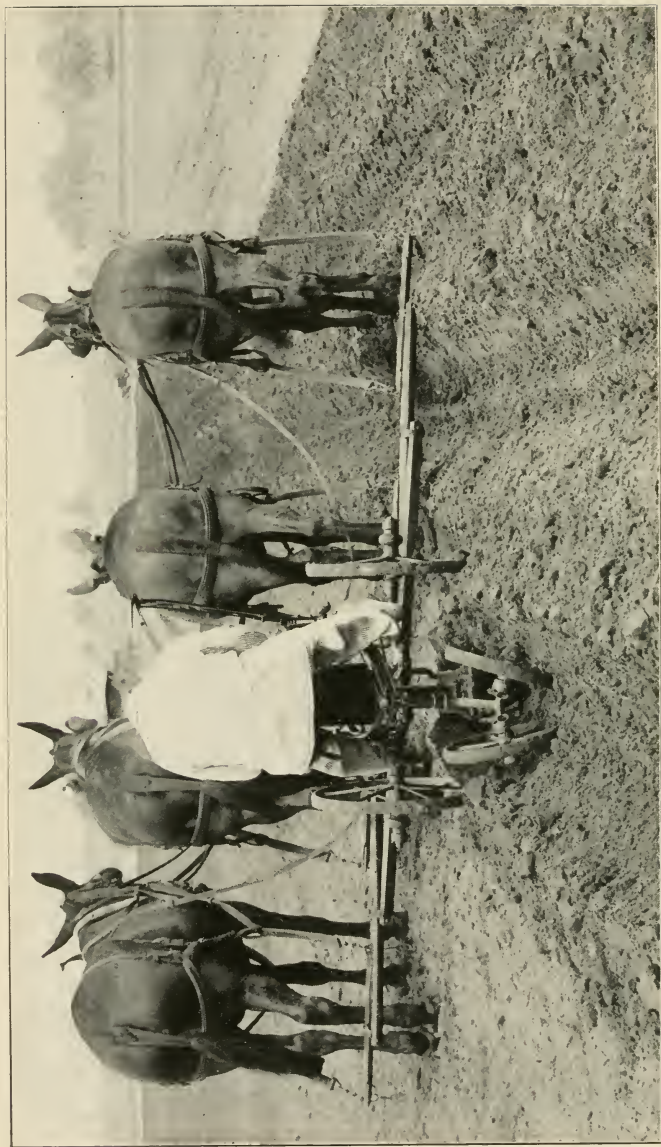

This system of middle breaking enables the operator to disturb the soil surface to such an extent that a great deal of the moisture is conserved. The later treatment breaks out the ridges helping to fill in the furrows made by the first breaking.

CHAPTER XXIII

Disk Plows

THE disk plow has altogether a different effect upon the ground than the mouldboard plow. The mouldboard plow turns the earth with a crunching, pinching, pulverizing motion while the disk plow turns the earth with a rolling motion. Naturally the earth turned with a disk plow will have more clods and larger ones than when turned with a mouldboard plow. The scrapers aid the disks very materially in covering trash and reducing the size of the clods.

Oftentimes ground becomes too dry to be successfully turned with a mouldboard plow. Primarily the disk plow was designed for turning soils in this dry, hard condition. It becomes apparent at once that such a plow can be used to good advantage in localities where fall sown crops are to be planted and the summer rainfall is apt to be scant. The rolling motion of the disk turning the furrow leaves the ground in a looser condition than a mouldboard plow, hence it better absorbs the rainfall that may come before the time of planting. For this reason there are plenty of farms on which both disk and mouldboard plows can be profitably operated in the season better adapted to their use.

The disk plows are in common use in gumbo, hardpan and black waxy soils where mouldboard plows will not scour.

A disk plow can be set to work in any type of soil but wherever a mouldboard plow operates it is better to use a mouldboard plow because it does a superior quality of pulverizing. The disk plow will not turn so good a furrow in a light sandy soil as a mouldboard plow will, neither does it work so well as a mouldboard plow in plowing weedy stubblefields or grasslands where mouldboard plows scour.

Dry plowing has been interesting farmers a great deal. The conclusion reached from the plowing of dry ground in the hot summer is that the evaporation of moisture from the sub-soil is greatly lessened and the land derives much greater benefit from driving rains. That is, more of the rainfall sinks into the ground. The weeds also get an earlier start, providing there is sufficient moisture in the ground, thus giving a better opportunity to kill them with a disk before sowing time. Earlier sowing also results. This has proved to be of special benefit in those localities where it is necessary for the crop to have a good start before the winter's freezing sets in. It has been proven many times that dry plowing immediately following the harvest is the means whereby a crop is made possible where otherwise none could be grown. This dry condition nearly always takes place on soil that cannot be plowed while hard and dry with a mouldboard plow.

The disk plow will handle very gravelly soil where a mouldboard plow cannot work. The principal reason for this is that the disk plow does not cut so wide a furrow as the mouldboard. The gravel in these narrow furrows is separated with the rolling motion of the disk much more effectively than can be done with the crunching, pulverizing action of the mouldboard. Another



Tractor disk plow showing the way the disk plow turns the soil and also that a straight furrow can be turned with one of these implements.

advantage of the disk plow in this type of plowing is that when it is desired to do deep plowing better results can be secured by having each disk cut a narrow slice.

Three disks equally spaced to cut 24" wide will naturally do better work than two disks spaced to cut 24" wide.

Many insect pests of which the grasshopper is the most common can be successfully fought with the disk plow because of its qualities for turning hard ground. It is a well known fact that grasshoppers lay their eggs in nothing but hard ground. Infested fields will produce grasshoppers the next year unless something is done to prevent such a calamity. Whether or not a farmer expects to plow the infested field in the fall he can very greatly diminish the crop of grasshoppers the following year if he will plow the preceding fall. There are plenty of sections in the United States where farmers could use the disk plow earlier in the season for no other purpose than this and save themselves several times the price of the plow in the next crop.

As to the draft required to pull a disk plow there is no evidence to show that it pulls any lighter than a mouldboard plow which turns over the same volume of earth. Many people deceive themselves into thinking that a disk plow pulls lighter. The reason for this is probably because the disk plow does not cut quite so wide a furrow as the mouldboard plow. This characteristic gives the disk plow an advantage over the mouldboard plow in that whether one cuts a wide or narrow furrow with the disk it always does an equal quality of work, whereas a mouldboard that cuts either a wider or narrower furrow than the width intended decreases the quality of plowing. A too wide furrow leaves an unplowed strip and in a too narrow furrow the ground is not properly pulverized.

The disks are sharp and placed on the frame so that they present a cutting edge to the soil very similar to

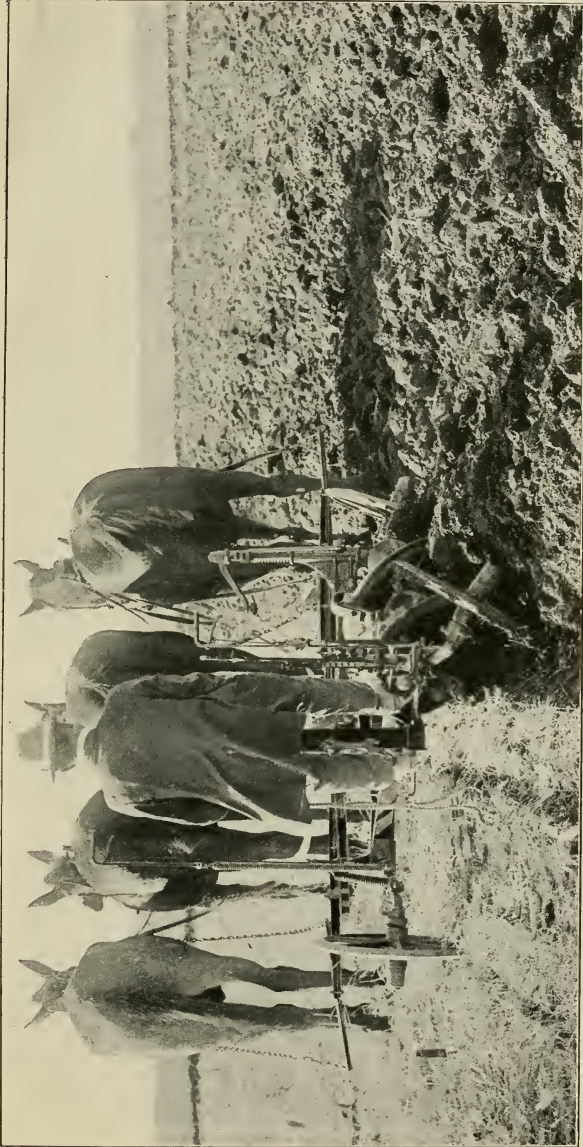

The disk plow turns this sticky, waxy soil to much better advantage than can be done with a mouldboard plow. This is the same type of soil exactly as shown in the illustrations on page 139. It is obvious that this sort of plowing is much better for this type of ground.

that of a knife blade when one whittles a stick. The disk has the advantage over the knife blade in that the edge of the disk cutting the soil is constantly changing. For this reason the edge of a disk will retain its sharpness a great deal longer than the edge of a share. This fact very probably has a great deal to do with the superiority of this type of plow over the mouldboard plow in exceedingly hard ground.

The principle of the draft of a disk plow is entirely different from that of a mouldboard plow. The shape of the share and mouldboard of the mouldboard plow cause the bottom to be pulled into the ground. On the other hand a disk plow must be forced into the ground by weight and draft combined.

In operating a disk plow the hitch in front should always be adjusted so as to keep the front of the plow in the ground and sufficient weight added to the rear to keep it in the ground at the desired depth.

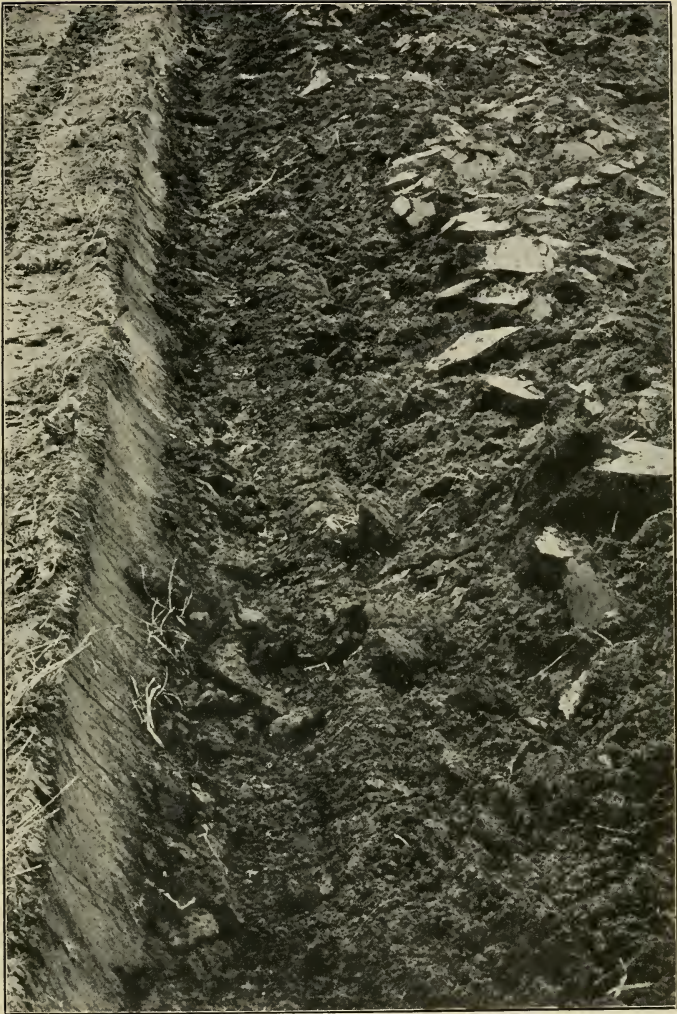

Notice the curved furrow wall and bottom and the way the earth is delivered as a turned furrow. It is entirely different from that of a mouldboard plow.

LIBRARY OF CONGRESS



0 021 928 614 4