

52
97407

上海幼稚師範學校叢書

兒童勞作教材

紙工

鄭青騎編

上海幼稚師範學校叢書社發行

膠州路檳榔路潘園

MG
G613.6
12

兒童勞作教材

紙工

鄭青騎編

上海幼稚師範學校叢書社



3 1797 2310 5

兒童勞作教材

紙工目錄

- I 摺紙教材..... (1 -13)
- II 剪紙教材.....(14-23)
- III 切紙教材.....(23-30)
- III 貼紙教材.....(31-39)
- V 組紙教材.....(40-44)
- VI 織紙教材.....(44-50)
- VII 裱摺教材.....(51-60)
- VIII 造花教材.....(60-73)
- IX 厚紙教材.....(74-86)
- X 印刷教材.....(87-94)



I

摺紙教材

要 旨

摺紙教材，係福祿培爾恩物表中的第十八種，是利用顏色紙，徒手來做成各種東西；他的教學效能，是訓練幼兒的手指和眼睛爲主的，以助長他們的創造能力；最初的時候，孩子們都因爲沒有摺紙的經驗，很難引起製作興味，教師不妨把講故事中的事物和紙摺的玩具玩給他們看，以鼓起學習興趣，由簡而繁，按步練習，以達到思考和創造之途。

準 備

A 材料 (1)紙料——各種紙料都可做摺紙教材的材料，不過要選擇得嚴格的，必須具有下列的幾個特點 (1) 富有韌性而不可過厚。(2) 色澤鮮麗正背二面必須相同。

教材1-2用透明紙，3用拭面紙，4用

玻璃紙，5—20用二號紙。

方 法

A 工作方法 (1) 裁紙——裁紙可不必在教摺紙時練習，教師應先將材料裁好，於實施時供給他們，形式如須正方形者，四邊要相等，長方形的，二對面互為平行，四個角度均須 90° 不得參差。

(2) 摺疊——摺疊要精確，方顯整齊。摺紙教材的工作圖畫法，大都把實線（——）來表示裁線，或摺的邊沿，把稀線（……）來表示摺線，鎖線（— · — · —）表示反摺線。

教 材

此項教材，用以教學幼稚園，和小學低級兒童，頗為適當，關於教材的選擇，宜順應兒童的心理和能力，教材的支配，處處宜設法與各科聯絡，材料的認識，和來源，價格等等，都可當作教學資料。

(1) 包糖菓



(A) 紙料的式樣和糖菓

(B) 把糖菓捲在紙料裏



(C) 二頭照樣絞緊

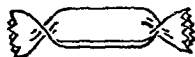

(2) 包橄欖

(A) 把三個橄欖捲在紙料裏



(B) 照樣絞緊



(C) 照樣環結

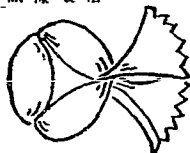

(D) 照樣打結

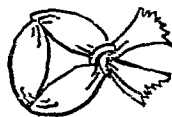

(3) 摺拭面紙

(A) 紙料式樣

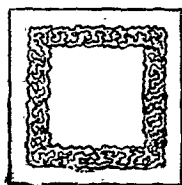

(B) 照樣線摺

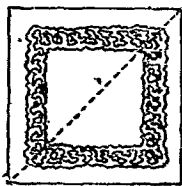

(C) 再摺

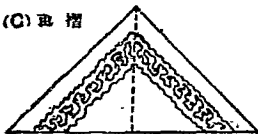

(D) 再摺



(E) 摺好的正面



(F) 摺好的背面



(4) 包藥粉

(A) 紙料的式樣

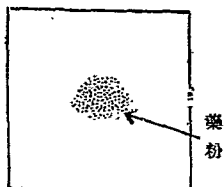

(B) 照樣摺疊

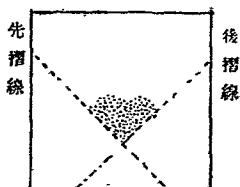

(C) 再摺

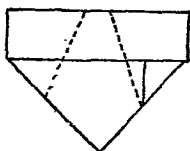

(D) 再摺

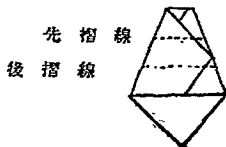

(E) 包好的正面



(F) 包好的背面



(5) 摺桌子

(A) 紙料的式樣

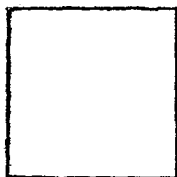

(B) 照摺

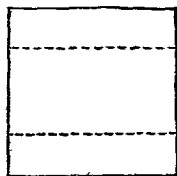

(C) 再照摺

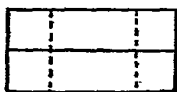

(D) 桌子式樣



(6) 摺椅子

(A) 紙料的式樣



(B) 照摺

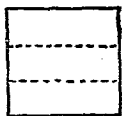

(C) 再摺

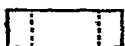

(D) 椅子式樣



(7) 紙箭的摺法

(A) 紙料式樣

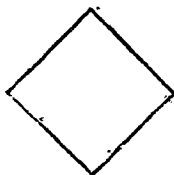

(B) 照摺

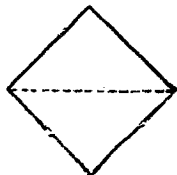

(C) 再摺



(D) 再摺

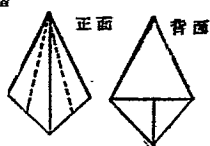

(E) 再摺

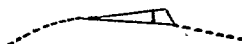
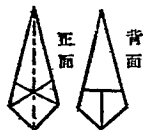

(F) 紙箭式樣

(8) 紙炮的摺法

(A) 紙料式樣

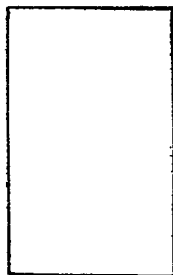

(B) 照摺

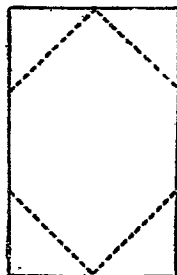

(C) 再摺

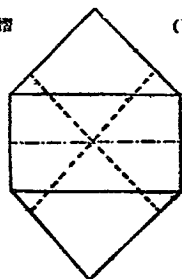

(D) 再摺

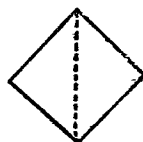

(E) 紙炮式樣



(9) 蚱蜢的摺法

(A) 紙料的式樣

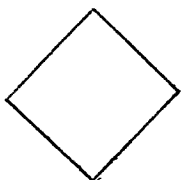

(B) 照摺

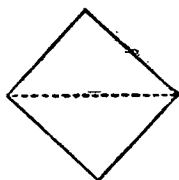

(C) 再摺



(D) 再摺



(E) 再摺

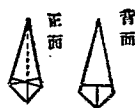
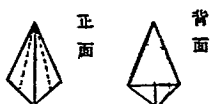

(G) 再摺



(H) 蚱蜢式樣



(10) 蝶的摺法

(A) 紙料式樣

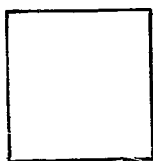

(B) 照摺

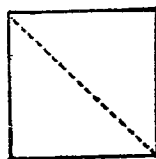

(C) 再摺



(D) 二角翻下



(E)再摺



(F)再摺



(G)鳩的式樣



(11) 鳩的摺法

(A)紙料式樣

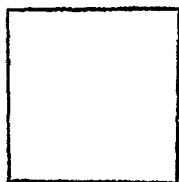

(B)照摺

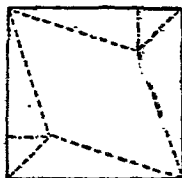

(C)再摺

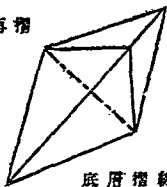

(D)再摺

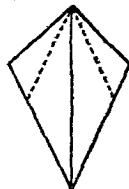

(E)再摺



(F)再摺



(G)鳩的式樣



(12) 紙鷹的摺法

(A) 紙料式樣

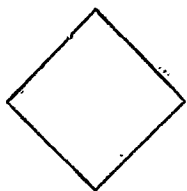

(B) 照摺

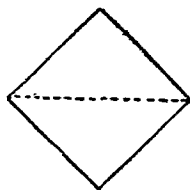

(C) 再摺

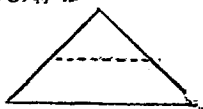

(D) 再摺



(E) 再摺

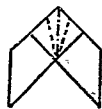

(F) 紙鷹式樣



(13) 馬的摺法

(A) 紙料式樣

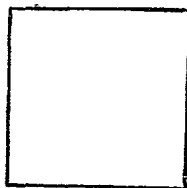

(B) 照摺

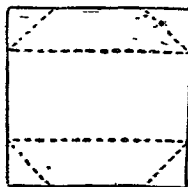

(C) 再摺

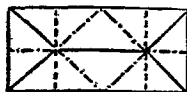

(D) 再摺



(E) 二頭翻出



(F) 馬的式樣



(14) 兔的摺法

(A) 紙料式樣

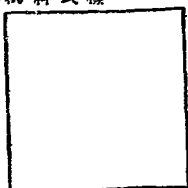

(B) 照摺

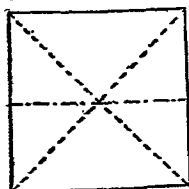

(C) 再摺



(D) 再摺



(E) 摺好的正面



(F) 翻身再摺



(G) 再摺

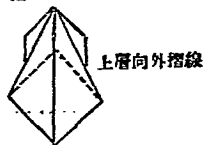

(H) 再摺



(I) 摺好吹氣



(J) 兔的式樣



415) 梔子花摺法

(A) 紙料式樣

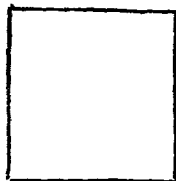

(B) 照摺

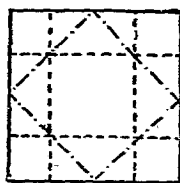

(C) 再摺



上層向
外摺線

(D) 再摺



上層
摺線

(E) 再摺



16) 燕子花摺法

(A) 紙料式樣

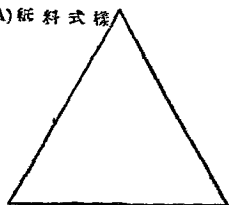

(F) 梔子花式樣



(B) 照摺

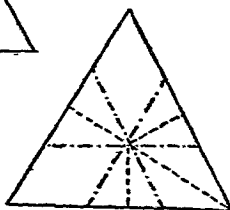

(C) 六面同樣摺



(D) 六面同樣再摺 (E) 摺好式樣 (F) 照樣把花瓣捲曲



(17) 紙盒摺法

(A) 紙料式樣

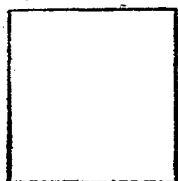

(B) 照摺

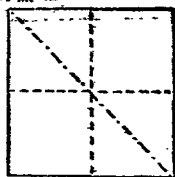

(C) 再摺

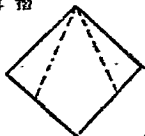

(D) 二面同樣照摺



(E) 四面同樣再摺



(F) 紙盒式樣



(18) 斛的摺法

(A) 紙料式樣

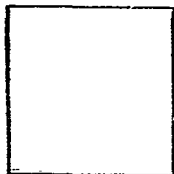

(B) 照摺

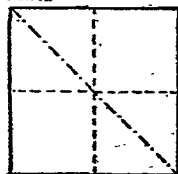

(C) 四面同樣摺

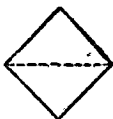

(D) 四角同樣摺



(E) 四面照摺並將四角扶入





(F) 摺好式樣



(G) 照樣張放



(19) 船板的摺法

(A) 紙料式樣

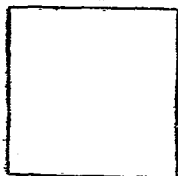

(B) 照摺

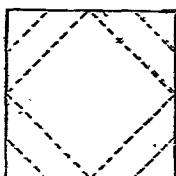

(C) 再摺

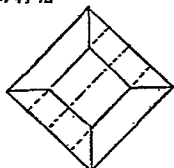

後摺線 先摺線

(D) 二面同樣照摺



(E) 二面同樣照摺

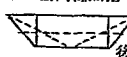

先摺線

後摺線



(F) 摺好式樣 (G) 照樣張放

(20) 童子軍營幕摺法

(A) 照摺

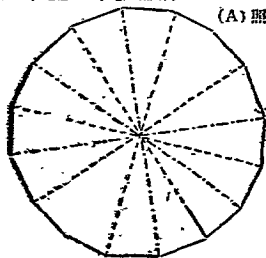

(B) 八面同樣照摺

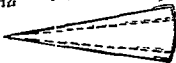

(D) 營幕式樣

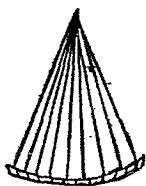

(C) 照樣向外翻出

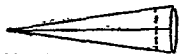

II

剪紙教材

要 旨

剪紙教材，係福祿培爾恩物表中的第十四種，利用剪刀由顏色紙中剪出各種形象，初期的訓練，大都用現成的圖物，給孩子們撕，由撕的經驗，再用剪刀來剪，以教學兒童的剪紙技能。

準 備

- A 工具 (1) 剪刀 —— 幼稚生和小學一二年級兒童所用剪刀，應在鐵店定製，柄上須加纏籐皮 或有橡皮護膜，儲藏時可浸漬在拍辣芬油中，以防生銹。其式樣如下：一

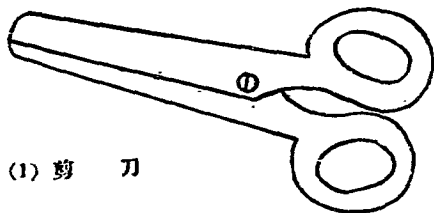

(1) 剪 刀

B 材料 (1) 紙料——舊報紙舊雜誌上

的圖物，如貓狗之類，為撕

紙剪紙教材絕好材料，教

師應先收集些，或由自己

在圖畫紙上製就圖物，以

作剪紙教材的材料，其他

如臘光紙，縐紋紙等亦可。

(2) 製圖用品——鉛筆應用 H

B或H硬鉛，如用複印紙須

採購上等者，油印亦可替

代。

C 其他 (1) 安全設備——橡皮護膜，

及止血藥劑。

方法

A 工作方法 (1) 撕剪——撕剪方法有下列三種，其工作順序分別敘述如次：一

1. 用手或剪刀把現成的圖物依樣撕剪

(A) 現成圖物

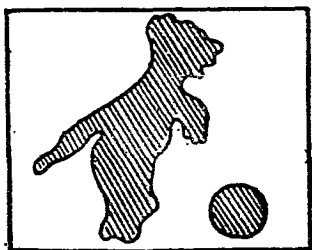

(B) 撕剪

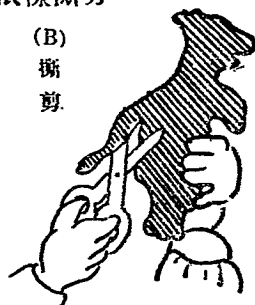

2 先摺後剪以節省手續

(A) 紙料摺摺

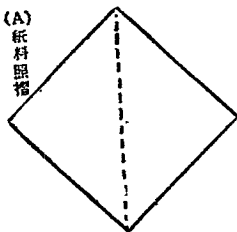

(B) 照實線剪



(C) 剪出楓葉模樣

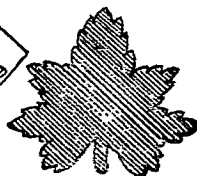

3. 先摺後剪再摺出各種動物姿態

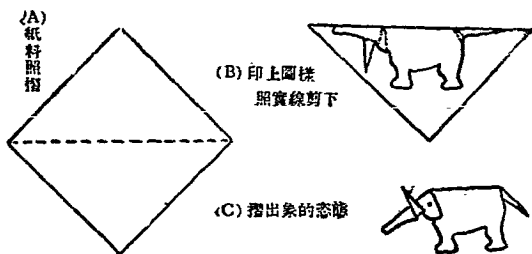

教 材

此項教材，適用於幼稚園和小學低級兒童，關於教材的支配，由撕剪簡單的輪廓線，而漸進於精緻細巧的各種模樣，材料的認識，和來源，價格等等，亦都可當作教學資料。

(1) 剪拖鞋樣(用新聞紙剪)

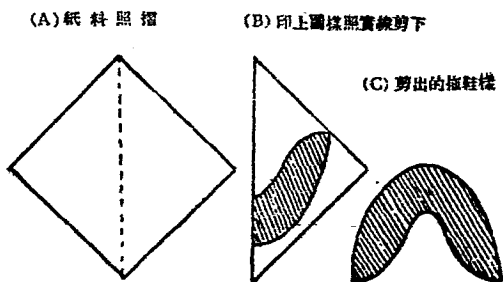

(2) 紀念盾模樣
(用蠟光紙剪)

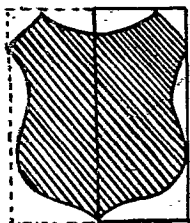

(3) 方
環
模
樣
(材
料
同
上)

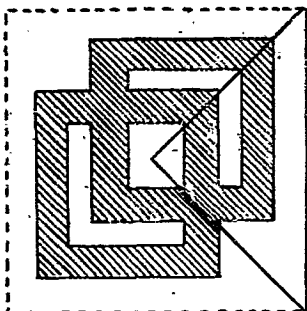

(4) 洛陽花模樣(材料同上)

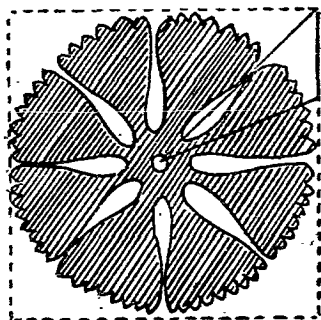

(6) 星 形(材料同上)

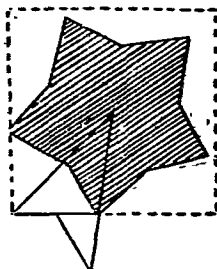

(5) 等邊三角形 (材料同上)

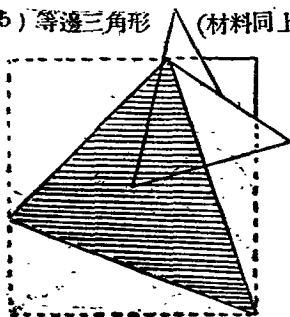

(7) 雪花模樣(材料同上)

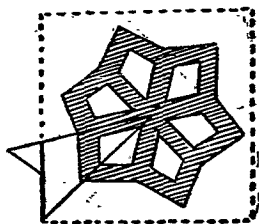

(8) 迴紋(材料同上)

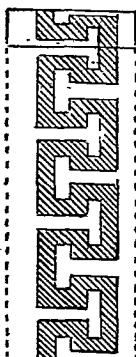

(9) 黨徽(材料同上)

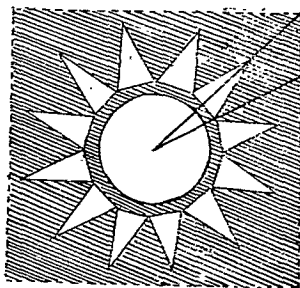

(10) 入結(材料同上) (A) 照摺

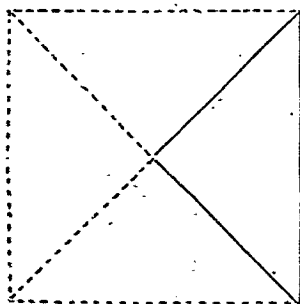

(B) 再摺

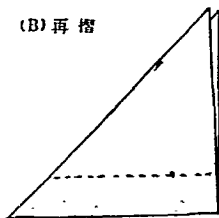

(G) 下層照摺

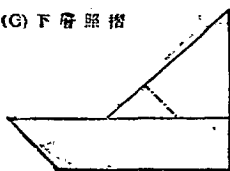

(D) 照摺



(E) 翻身再摺

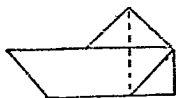

(F) 摺好的正面



(G) 翻身照剪

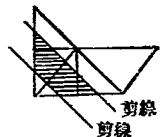

(H) 剪成的八結式樣

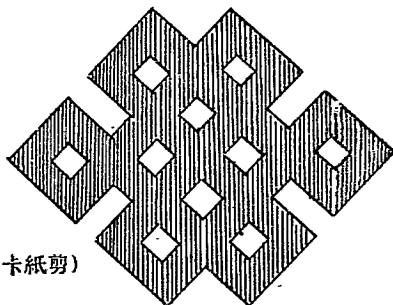

(11) 小雞

(用重磅圖畫紙或白卡紙剪)

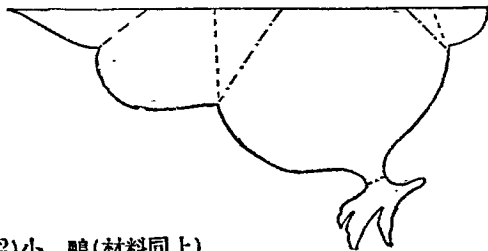

(12) 小鴨(材料同上)

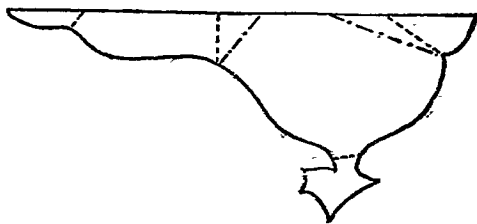

(13) 牛 (材料同上)

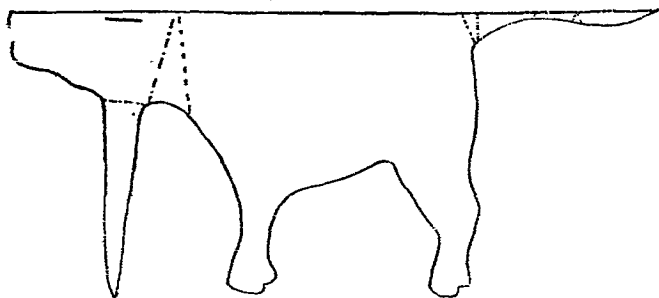

(14) 馬 (材料同上)

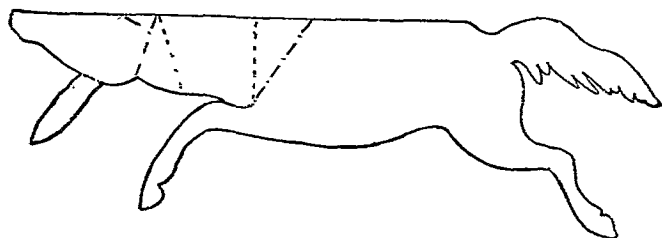

(15) 猪 (材料同上)

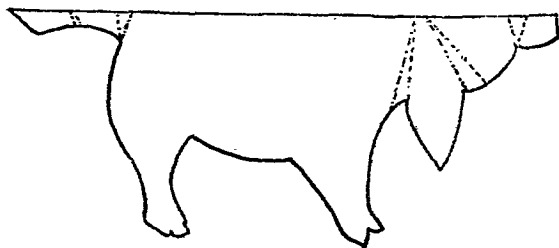

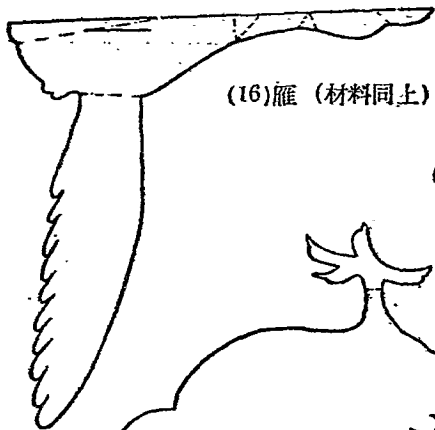

(16)雁 (材料同上)

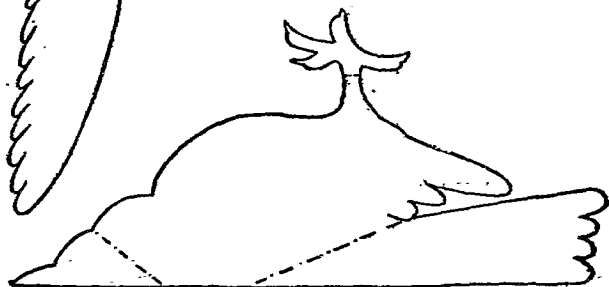

(17)雀 (材料同上)

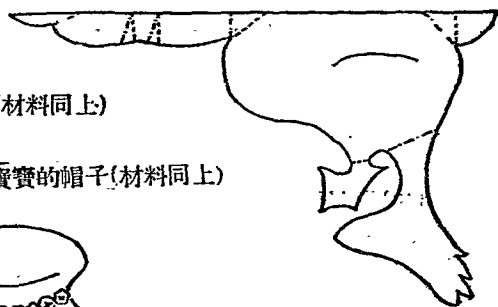

(18)鶴 (材料同上)

(19)小寶寶的帽子 (材料同上)

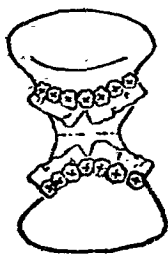

(20)小寶寶的衣裳(用縐紋紙剪)

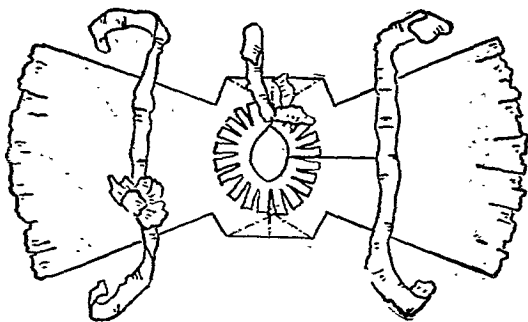

III

切紙教材

要旨

切紙教材，用切紙刀來教學切紙的方法，以增進其工作技能。

準備

A 工具 (1)切紙用具——切紙的工具，手工上所用的是切紙刀，公尺，及三角板等，其式樣如下：—



(1) 切紙刀



(2) 公尺

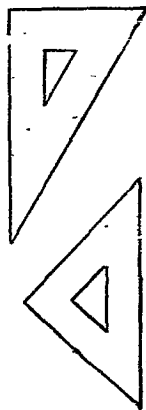

(3) 三角板

其他如玻璃等，亦甚須要，襯墊在工作台上，切時可較為平滑。

B 材料 (1) 紙料——教材1—5用馬糞紙，6—10用拷貝油紙，11—15用厚馬糞紙或深色之書面紙，16—19用馬糞紙及縐紋紙，20用新聞紙。

(2) 製圖用品——複印紙，硬鉛筆。

C 其他 安全設備——同剪紙教材

方法

A 工作方法 (1)製圖——先把複印紙和鉛筆將圖樣印在紙料上。

(2)切法——用切紙刀依照圖樣切線(——)切下。切成直線者，將公尺擡持紙料，用切紙刀沿公尺的銅邊裁切整齊。

教 材

此項教材，適用於小學中級兒童。教師在課餘的時候，可率領他們到紙盒作，或印刷工場去參觀機械的切紙方法。關於材料的認識，來源，價格，製品的用途，都可當作教學資料，使用量具尤宜注意。

(1)碗



(2)牛奶杯

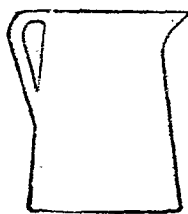

(4)戟



(3)斧



(5)山雞



(以上(1)-(5)教材都可用馬糞紙剪切用色鉛筆或蠟筆等着色黏貼於深暗色之書面紙上)

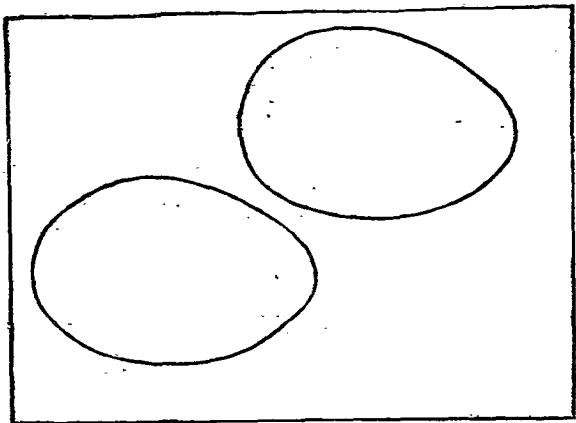

(7) 蜂

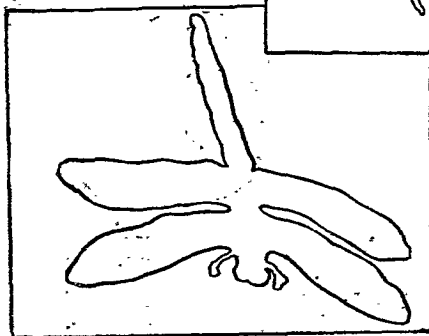

(8) 蜻蜓

(9) 單色印花紙版



(10) 複色印花套版

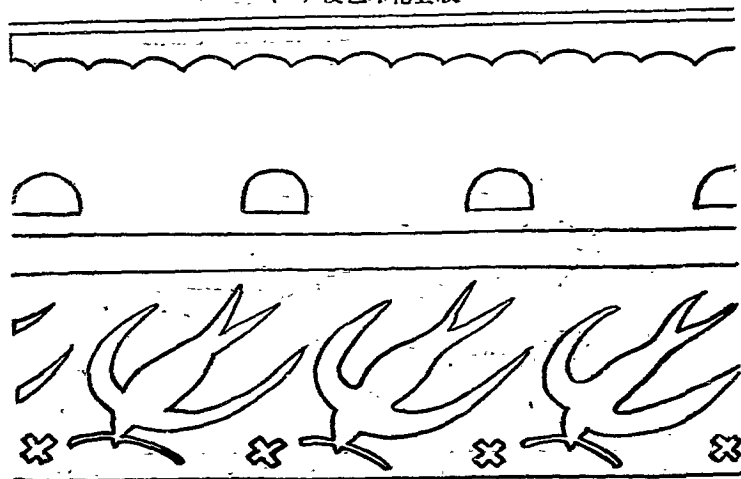

(以上(6)-(10) 教材係用拷貝油紙剪切之噴印用型版)

(11)
蟲

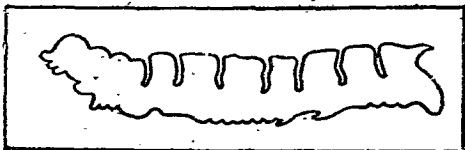

(12) 小鳥
(13) 狗

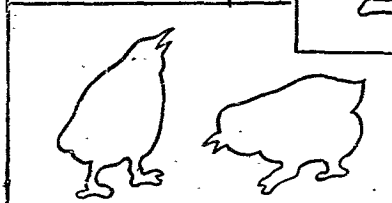

(14) 小雞

(15) 狼

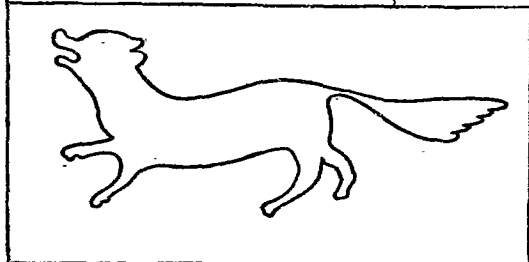

(以上(11) - (15)教材用馬糞紙剪切者可作畫圖型版用深色書面紙切下中實棉花形成各種昆蟲禽獸圖案亦頗饒興趣)

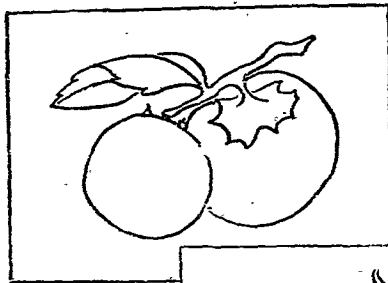

(16) 柿

(17) 花 (-)

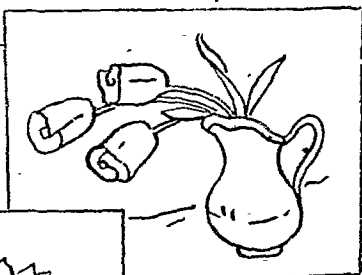

(18) 花 (二)

(19) 花 (三)

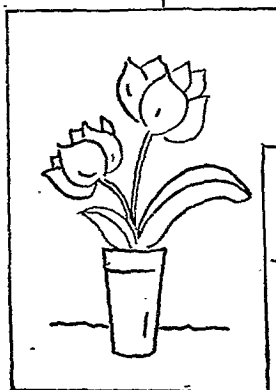

(以上(16)-(19)教材
用馬糞紙分別切下平鋪棉
花外包以緞紋紙或綢布黏
貼於圖畫紙上名凸花教材
亦切紙教材之一種)

(20) 切新聞紙(用新聞紙切)

(A) 照切線切齊



(B) 切齊之紙料



III

貼紙教材

要 旨

貼紙教材，又名剪貼，亦是福祿培爾恩物表中的一種，利用撕紙和剪紙的成績，黏貼起來湊成圖物。或將紙料黏貼在其他物品之上，以練習紙屬接貼方法及配色技能。

準 備

- A 工具 (1) 剪刀——與剪紙教材同。
(2) 糊刷——排筆，或漿糊刷帚，括漿刀。

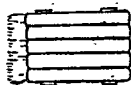

(1) 排 筆 (2) 號 糊 刷 帚 (3) 括 漿 刀

- B 材料 (1) 紙料——各色蠟光紙，或剪紙撕紙成績，書籤 商標貼頭，信封 郵票 剪報簿，報紙，標語，印花紙，圖畫紙等。
(2) 糊料——樹膠水，或漿糊。惟糊料中之防腐劑，不可加石炭酸，宜用水楊酸，較為安全。

C 其他

(3) 製圖用品——硬鉛筆,複印紙。

(1) 安全設備——與剪紙教材同。

(2) 清潔用具——面盆,毛巾,肥皂。

方 法

A 工作方法 (1) 剪切——將所需之圖樣,用製圖用品,描繪在紙料上,依樣剪切。如書籤,商標貼頭,信封,郵票,報紙,標語,印花紙,圖畫紙,蠟光紙,以及撕紙剪紙成績,均可。

(2) 黏貼——次以糊料塗刷于背面,挨次黏貼於圖畫紙上,或書本及商品牆壁等處。

教 材

此項教材,適用於幼稚園和小學中低級兒童,關於材料的認識,來源,價格,及配色方法,都可當作教學資料,手的衛生,尤宜注意。

(1) 封 信 口

(A) 在有膠水處

() 用水沾溼

(B) 照樣封口

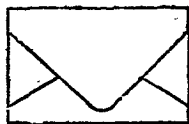
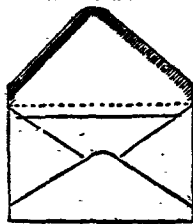

(2) 貼郵票

(A) 在郵票背面
有膠水處沾水

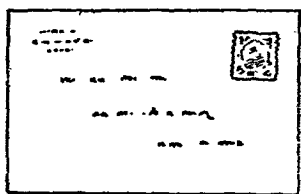

(B) 把郵票貼在信封上

(3) 貼書籤

(A) 在書籤背面
有膠水處沾水

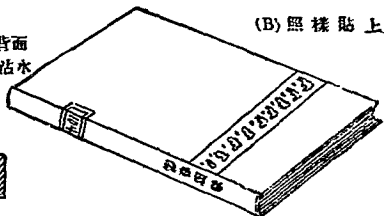

(B) 照樣貼上

(4) 貼剪報簿

(A) 把報紙上愛看的圖畫或文字剪下

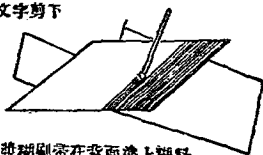

(B) 用漿糊刷帚在背面塗上糊料

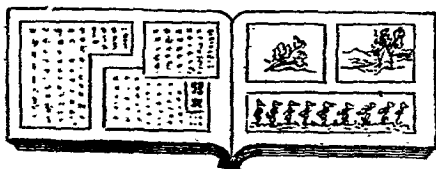

(C) 把塗上糊料的圖物貼在剪報簿上

(5) 貼花露水瓶裝璜

(A) 背面塗上糊料

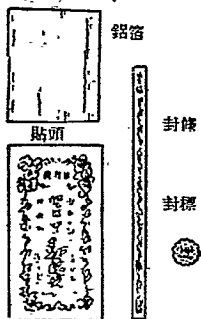

(B) 把鋁箔封瓶口



(6) 印花紙貼法

(C) 把各種貼頭貼上

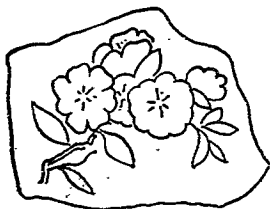

(A) 把印花紙的正面用水沾溼

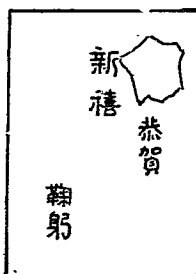

(B) 照樣貼上再用水沾溼背面輕輕揭去印花紙其花紋即與原紙脫離

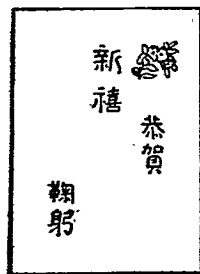

(C) 印就後之式樣 (印花紙係一種膠質塗料所印成之各種花紙在工業上用途甚廣如製袋及織器上所印有之花紋大部應用此種方法)

(7) 辣椒

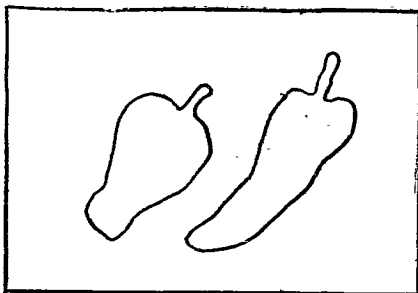

(8) 蝴蝶

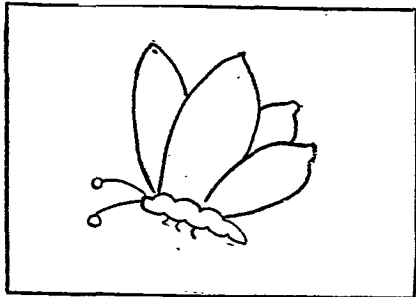

(9) 蘿蔔

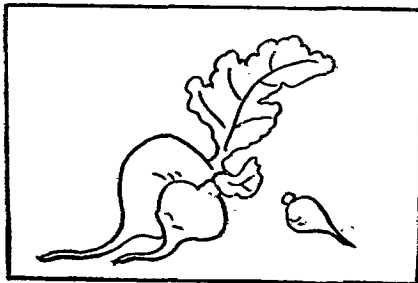

(10) 柿與香蕉

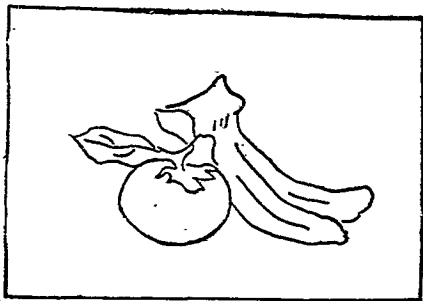

(11) 蠶與桑葉

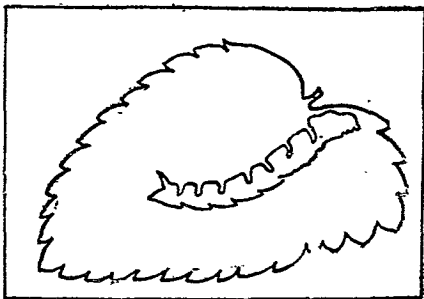

(12) 花

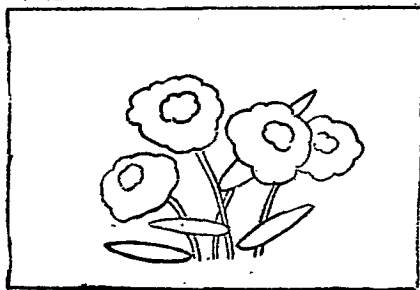

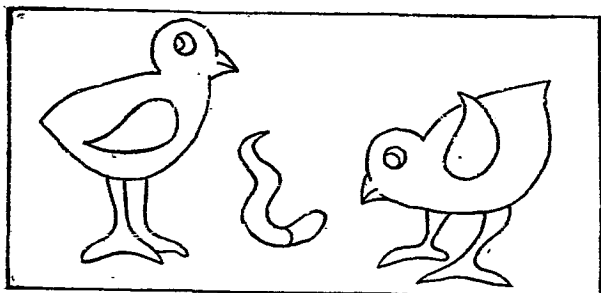

(13) 小雞和蚯蚓

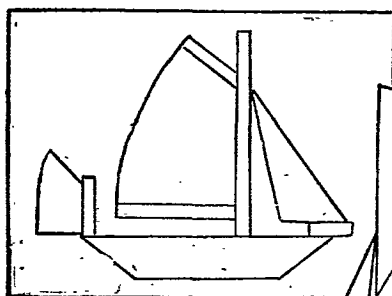

(14) 帆船

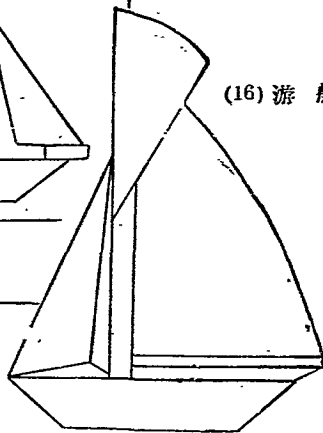

(16) 游艇

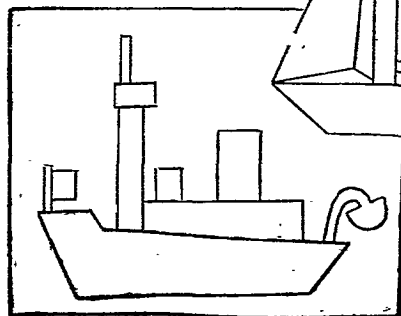

(15) 渡輪

(17) 大輪

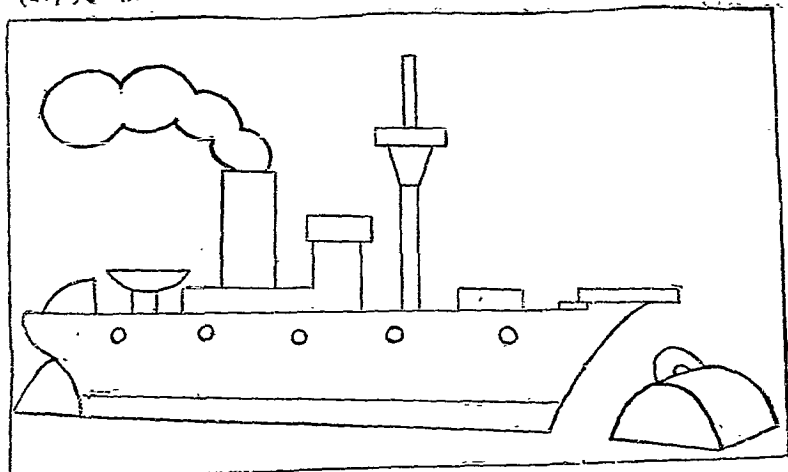

(18) 雙兔

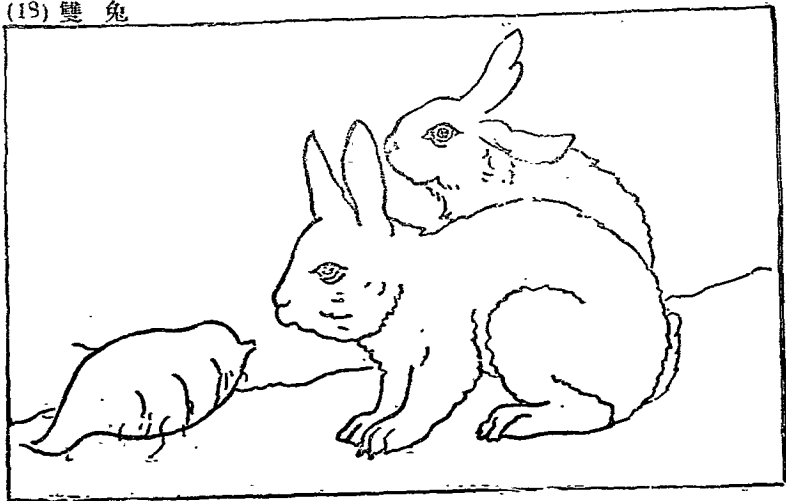

~~~~~

(19) 總理像



(以上(7) - (19)教材用蠟光紙照樣分別剪下黏貼於圖畫紙上)

(20) 貼標語

(A) 先用排筆將糊料刷在壁上

(B) 再以標語紙張貼其上

(C) 再用乾刷塗刷平

## V

### 組紙教材

#### 要旨

組紙教材，係福祿培爾恩物表中的第十七種，能長短伸縮，變化無窮，是訓練兒童的手指運動和視覺的教材，為教學織物之預備，增進其簡易的編織技能。

#### 準備

**A 工具** (1) 剪切用具——剪刀同剪紙教材，切紙刀同切紙教材

**B 材料** (1) 紙料——各色紙條，闊5公釐或1公分，色彩宜鮮明，正背二面均須相同，且須富有韌性，如書面紙等。其他裱褙用紙，可以輕磅圖畫紙充之。

(2) 糊料——同貼紙教材

## 方法

A工作方法 (1)組法——取各色紙條，組成各種簡單圖案或器物。

(2)黏貼——組成後，須將二端先行貼接，如係平面者，黏貼於圖畫紙上，保留為成績。

## 教材

此項教材，適用於幼稚園和小學中級及低級兒童。

(1) 三角形

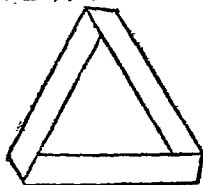

(2) 菱形

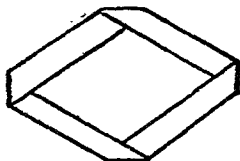

(3) 井字形

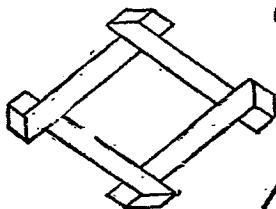

(4) 雙三角形

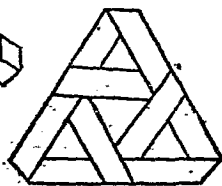

(5) 蝶形(一)

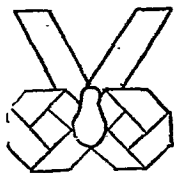

(6) 蝶形(二)

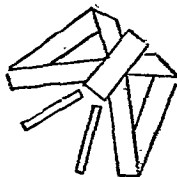

(7) 五角形

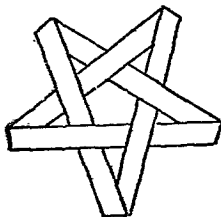

(8) 七角形

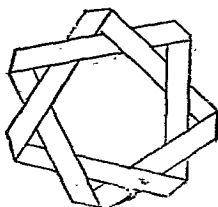

(9) 六角形

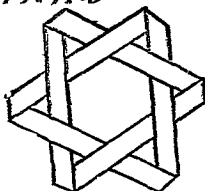

(10) 八角形

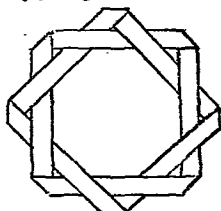

(11) 雙方環形

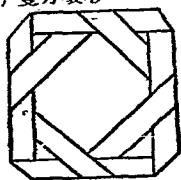

(12) 花形

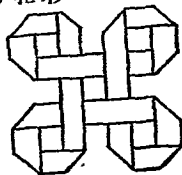

(13) 連續模樣(一)

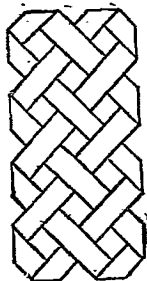

(14) 八結形

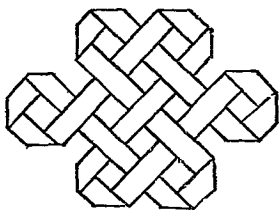

(15) 文字形

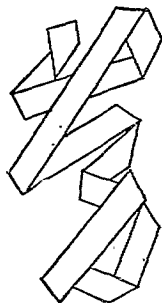
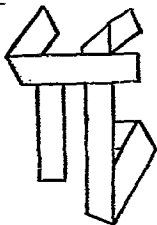

(16) 連續模樣(二)



(18) 菊形



(17) 多角菱形

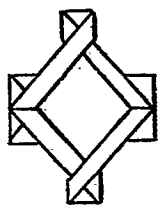

(19) 貓頭

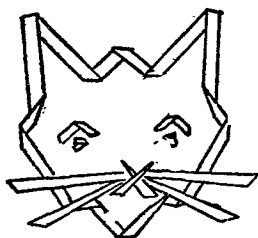

(20) 提籃

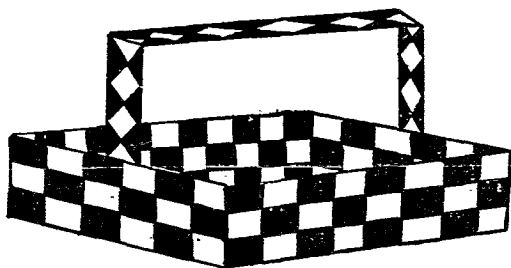

## VI

### 織紙教材

#### 要旨

織紙教材，係福祿培爾恩物表中的第十六種，利用顏色紙條織成圖案，以養成其精細動作發育的基礎。

---

## 準 備

A 工具 (1) 剪切用具 —— 剪刀, 切紙刀, 襯墊用  
玻璃, 同剪紙切紙教材。

(2) 量 具 —— 公尺, 三角板。

B 材料 (1) 紙 料 —— 各色蠟光紙。

(2) 糊 料 —— 同貼紙教材。

(3) 製圖用品 —— 鉛筆, 公釐格等

C 其他 (1) 安全設備 —— 同剪紙教材。

(2) 清潔用具 —— 同貼紙教材。

## 方 法

A 工作方法 (1) 製圖 —— 先取公釐格作一圖樣,

次用量具與製圖鉛筆精密地在

蠟光紙的背面製圖。如下:



1. 平織經紙的畫法

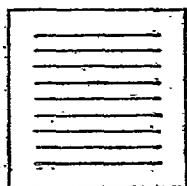

2. 斜織經紙的畫法

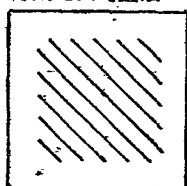

3. 緯條畫法

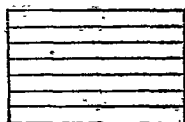

4. 緯條切法

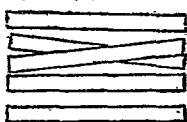

(2) 切法——依照實線用切紙刀切。

(3) 織法——依照圖樣把緯條挨次，織入經紙中間。

(4) 黏貼——把緯條的二端，用糊料黏貼在經紙的二邊。

### 教 材

此項教材，適用於小學中級兒童，並宜搜集各種織物圖案提供參攷。

(1)

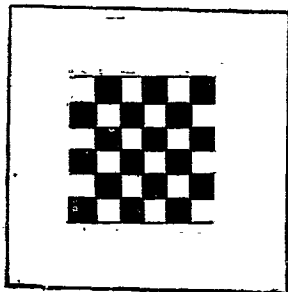

(2)

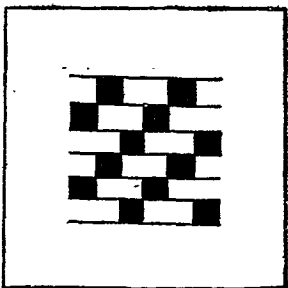

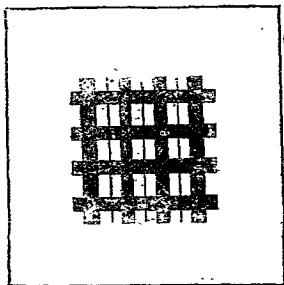

(3)

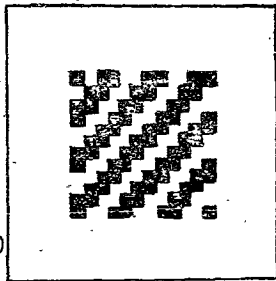

(4)

(5)

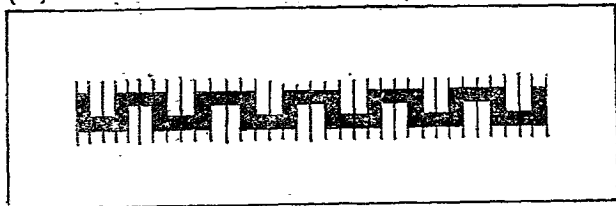

(7)

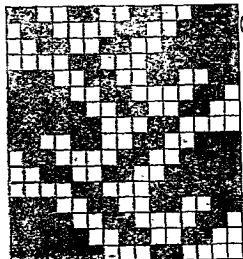

(6)

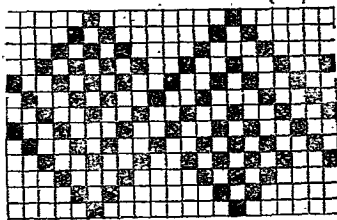

(8)

(9)

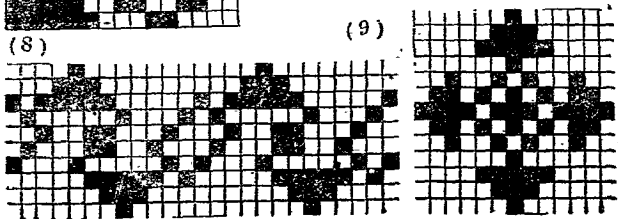

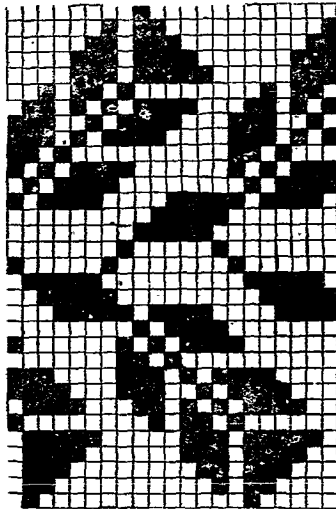

(10)

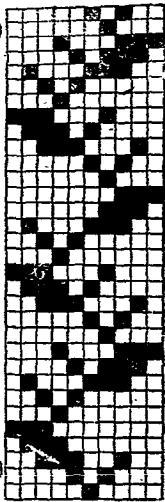

(11)

(12)

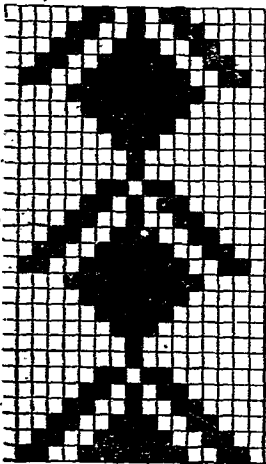

(13)

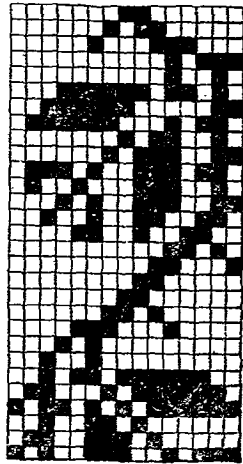

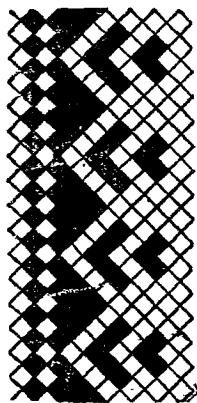

(14)

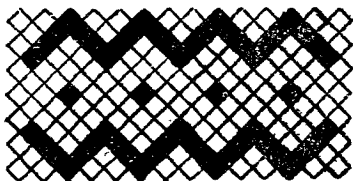

(16)

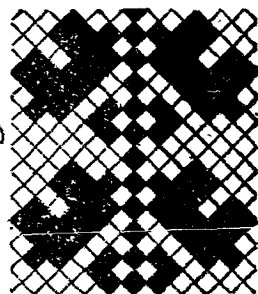

(17)

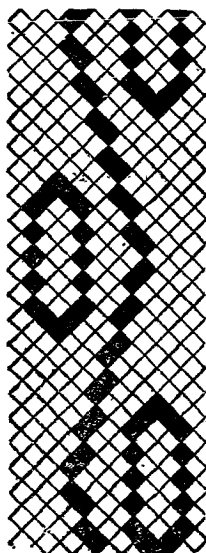

(15)

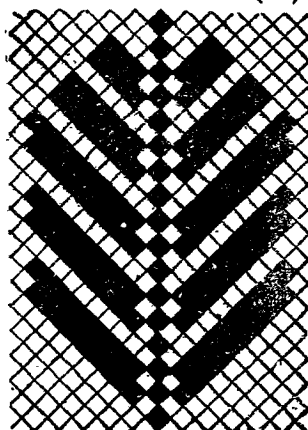

(18)



(19)

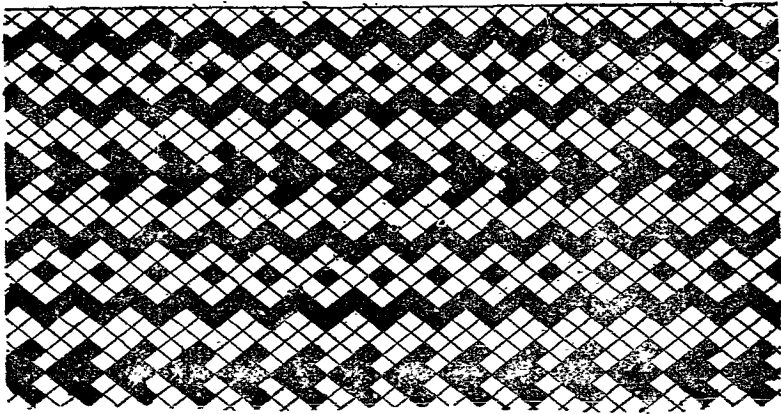

(20)

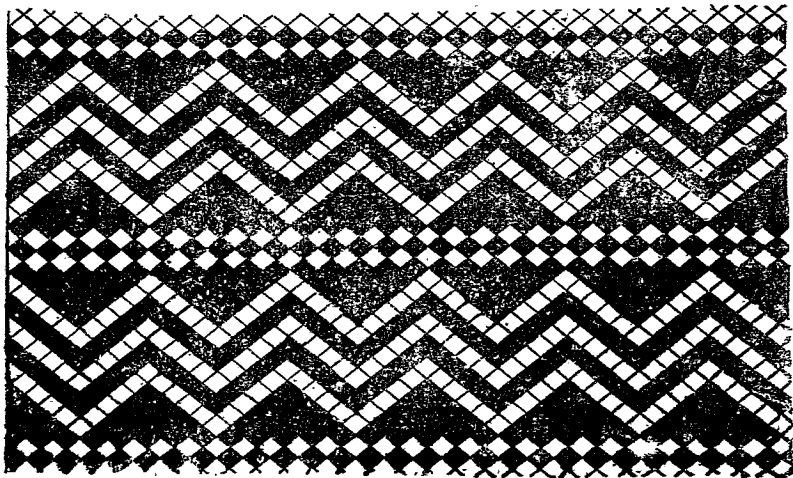

(.50.)

## VII

# 裱 褙 教 材

---

### 要 旨

裱褙教材,是利用糊料,糊裱各種紙料的一種教材,以訓練兒童紙屬裱褙的工作技能,增進其生產興趣。

### 準 備

A 工具 (I) 糊具——糊砵 即普通之砵頭,排筆見貼紙教材,棕帚式樣如下圖,台板要平滑。

(I) 棕帚



B 材料 (1) 糊料——薄糊料用澱粉酌加明礬,將沸水沖調。

(2)紙料——裱面用紙，有宣紙，連史紙，冰浪箋，硃箋，毛邊紙，棉筋紙，桑皮紙，玻璃花紙，裱糊壁面花紙，新聞紙，及其他彩紙，絹，綾等類。裱心用紙如裱心紙，舊報紙等。裱背用紙。有用裱面紙者，有用牛皮紙，桑皮紙等。

### 方 法

A 工作方法 (1)攤紙——裱面紙宜平張於台板，或其他物件之上，再洒水，用乾棕帚刷平。

(2)糊裱——先將已攤好之裱面用紙上，用排筆蘸些薄糊料刷上，次以裱心用紙攤上，用乾棕帚刷平，層次多少，以製品之厚薄為標準。如糊裱廢紙教材者，先以模型用水貼上裱心紙一層，再將裱心紙用糊料刷上二三層，又用舊報紙等糊上五六層，外

再裱以裱心紙二三層，待乾，劈開，取出模型，用牛皮紙黏合劈縫，再裱裱心紙二三層，外糊棉筋紙一層，各層紙料，均宜撕成小塊貼上，否則不易張平，致失原形。糊裱燈彩，風箏，團扇等，只須在紙料的邊沿上，刷以糊料，將紙料張平于鉛絲或，篾圈上。

- (3) 糊裱背用紙——用裱背紙者，俟裱心紙裱上後，再覆上裱背紙，其裱褙方法，與糊裱心紙同。

### 教 材

此項教材，適用於小學各級兒童，教材之支配，以視其作物繁簡而定。關於材料的認識，來源，價格等，都可當作教學資料。裱糊工作場所，如裱畫作等處，隨時可帶往參觀。

- (1) 裱厚紙——用新聞紙，做裱面



紙·用舊報紙，做裱心紙，裱背紙，同裱面紙，裱後待乾，可作厚紙代用品。

- (2) 裱糊信封——用宣紙，或連史紙，做裱面紙，用新聞紙，做裱背紙。厚薄二層已够，故可不用裱心紙，糊裱後，待乾備用。
- (3) 裱製植物標本用襯紙——用連史紙，或宣紙，做裱面紙，用新聞紙，做裱心紙及裱背紙，式樣按照標本之大小而定。
- (4) 裱賬簿封面用紙——用棉筋紙，或連史紙，做裱面紙，新聞紙，或裱心紙，做裱心用紙，裱背用紙，式樣須依照賬簿尺寸而定，有用布裱者，經用耐久，其法亦同。
- (5) 裱書籍封面用紙——其方法與上項教材相同；惟裱面紙，有

用宣紙，連史紙，或冰浪箋，絹，綾等類者

(6)書畫裝池——裱書畫略同前法；惟工作較繁而已。其法先以清水揩淨台板，攤上裱面紙洒濕，紙背用乾棕帚刷平，以排筆將糊料刷在裱面紙的背面，攤上裱心紙刷平，至數層厚，再合上裱背紙。（如須鑲邊者，須先鑲後貼）四週稍刷糊料，揭起，將紙背貼在壁上，待乾裝軸。

(7)裱團扇——團扇上糊裱紙料，有用宣紙 有用綾裱，其式樣如下。

團扇

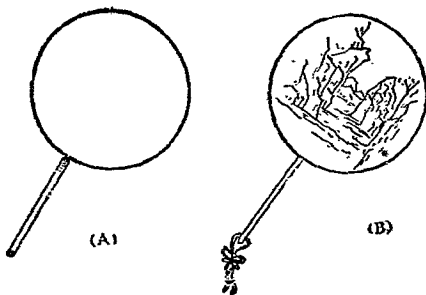

(8) 裱糊燈罩——用美麗的紙料做裱面紙和裱背紙裱糊方法不宜過厚藉以透光

(A) 照樣摺貼

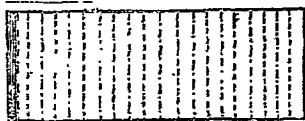

(B) 穿孔結帶

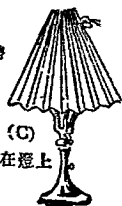

(C) 裝在燈上

(9) 紙彩——其工作法如下

(A) 照摺

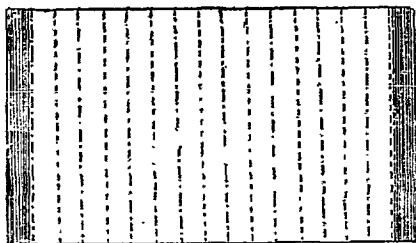

(B) 照剪



(C) 照剪

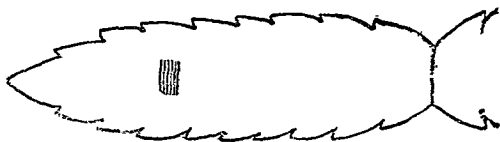

(D) 照貼



(10) 風箏——其裱糊方法如下

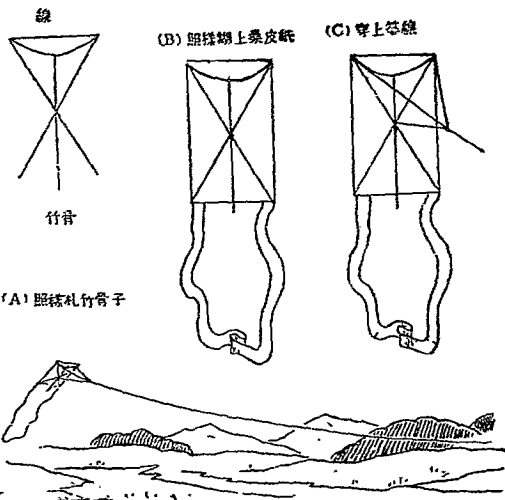

(11). 走馬燈——糊裱方法與上項教材相同其結構如下

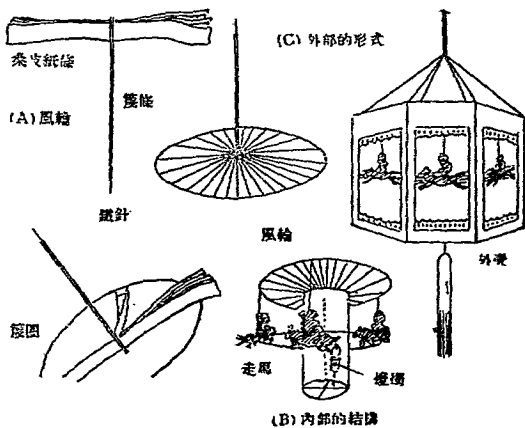

---

(12) 張貼玻璃花紙——先把玻璃花紙，依照窗格大小裁切，次以襯紙撕去，張于玻璃窗上，用濕棕帚刷平，花紙因受潮濕與玻璃膠合。

(13) 糊裱壁面花紙——先把壁面整理清潔補平，再將花紙刷以糊料張上，用乾棕帚刷平，花紙圖案，宜配合準確

(14) 假面具——假面具，預先用木材，或黏土做成模型，以做廢紙教材的方法裱糊之，待乾，外塗白膠粉（白膠粉調製方法，用鉛粉或白石粉，加以膠水。）待乾着色（塗料用廣告畫顏料，惟須加重膠汁。）

(15) 茶盤——用茶盤模型，照廢紙教材方法糊裱，塗較厚之白膠

---

粉，待乾，用沙紙打磨平滑，外施以假漆。

(16) 紙製蘋菓——取真實之蘋菓做模型，按照廢紙糊裱方法，糊裱，外塗以白膠粉，待乾，打磨平滑後，再施以色彩，膠汁顏料，或假漆均可。

(17) 紙製南瓜——取真實之南瓜做模型，其法與上項教材同。

(18) 紙花瓶——取真實之花瓶做模型，製法與上項教材同；惟塗料須用假漆，在假漆，未乾燥時，用金粉，或銀粉，撒上，色彩極為富麗

(19) 紙製動物模型——取各種玩具做模型，方法與上項教材同，裱

---

面紙用棉筋紙，預先染色，撕毛，由動物之尾部 挨次糊裱至頭部，有毛頭處，可不沾糊料，糊成後，酷如獸類皮毛，眼睛用半圓球形之玻璃，于平面處，以假漆繪以眼珠，貼于相當之處。

(20) 地圖模型——先以黏土製成地圖模型，再用廢紙教材糊裱方法糊裱，施色可用假漆，其細小之道路等，有用紙貼，有用筆畫，一切均須按照地圖原樣設色。

### Ⅲ

## 造花教材

造花教材，是利用紙料，或絹紗等類之材料，仿造

~~~~~  
各種植物姿勢形態，其用絹紗通草製者，應用工具較繁，故不合于兒童教學，用縐紙製者，工具簡單，手續便捷，頗有製作興味。

準 備

A 工具 (1) 剪切用具——剪刀，同剪紙教材。

B 材料 (1) 紙料——縐紙，花蕊。

(2) 鉛絲——粗細鉛絲。

(3) 糊料——厚漿糊。

(4) 蠟料——石蠟。鯨蠟。

方 法

A 工作方法 (1) 剪切——先用厚紙依照花瓣葉片剪成型板，次將型板襯上縐紙，依樣剪切。

(2) 製瓣及製葉——將剪切好之花瓣，用雙手在中部攀寬，翻身將花瓣捲曲，

(A) 此處摺寬



(B) 此處捲曲



製葉方法如下：——

(A) 細鉛絲



(B) 照樣用紙條捲上



(C) 半面塗上糊料



(D) 把葉片放平將已捲好紙條塗
上糊料之葉柄貼上



(3) 扎花及製莖——扎花及製莖方法如下：

(A) 照樣扎上花蕊

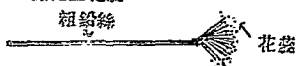

(B) 加上花瓣

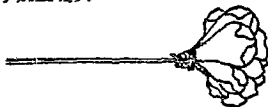

(D) 酌加葉片



(C) 添上花萼捲上紙條



(E) 製成花朵



- (5) 上蠟——已製就之花，浸入蠟液中（蠟液之調製方法，用石蠟一磅，加鯨蠟一盎司，熱至寒暑表上120—150而成。）迅速取出，並將餘蠟洒去，待冷即成蠟花。
- (6) 貼花——貼花簡便易行，祇要把花瓣剪就攀寬後，將下端用糊料黏貼在圖畫紙上，再加貼紙製的花蕊，及葉片莖枝等。

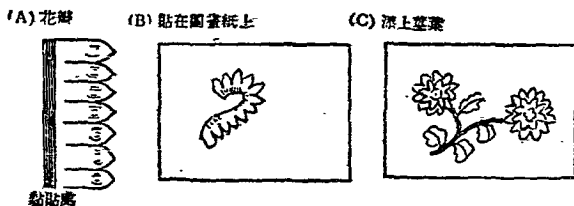

教 材

此項教材，適用於小學中級兒童，並宜採集各種植物，或教師自製的範作，提供參攷。關於材料的認識，來源，價格等，都可當作教學資料。

(1) 貼梅花(方法見貼花法)

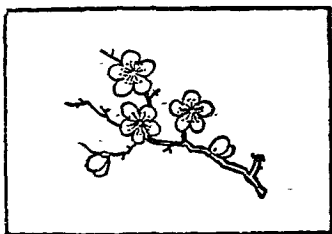

(2) 葵花(貼花)

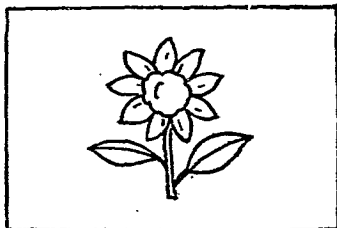

(3) 雞冠花(貼花)

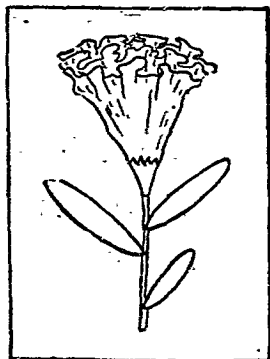
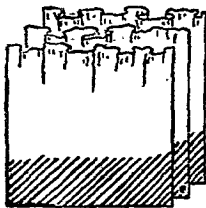

(4) 水仙花(貼花)



89

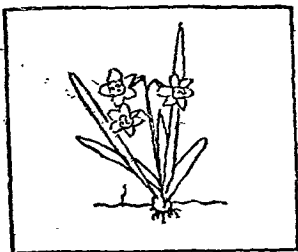

(5) 菊花(貼花)

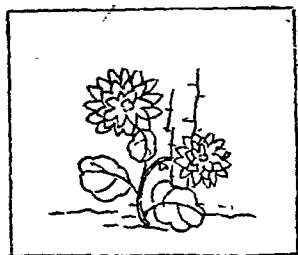
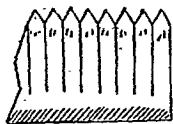

(6) 桃花

花瓣(桃紅色)



桃葉(草綠色)



(7) 石榴紅

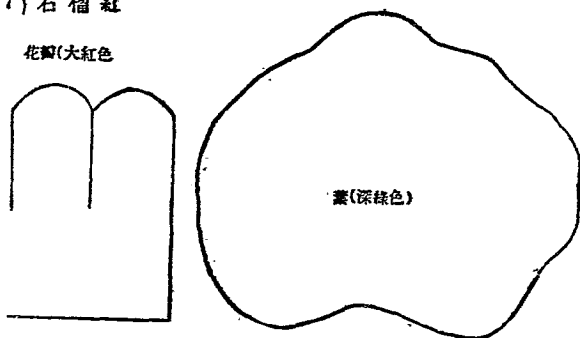

(8) 豈花

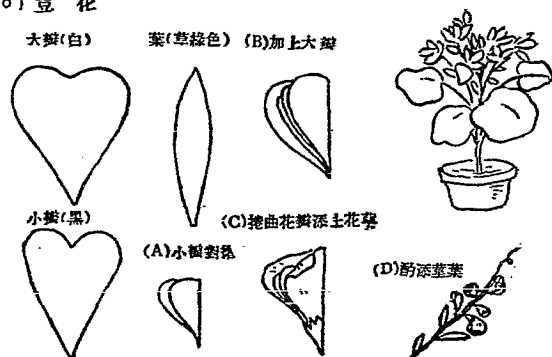

(9) 侖儷花

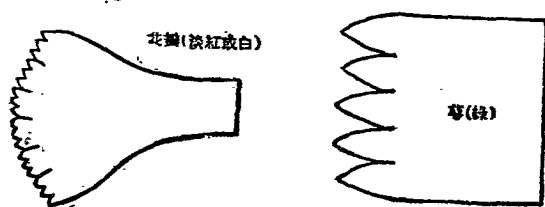



葉(綠)

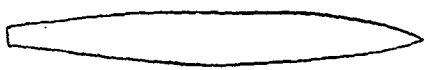

(10) 牽牛花

葉(綠)

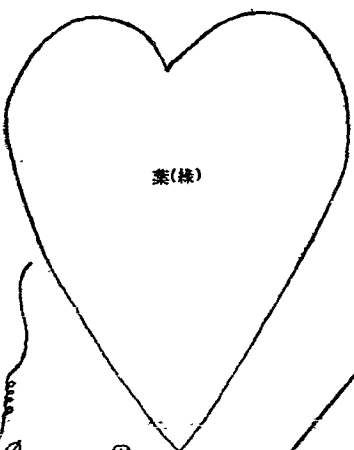

莖(綠)

花瓣(淺紅或淡紫等)

(A)花瓣糊成筒狀



(B)瓣口要寬闊出

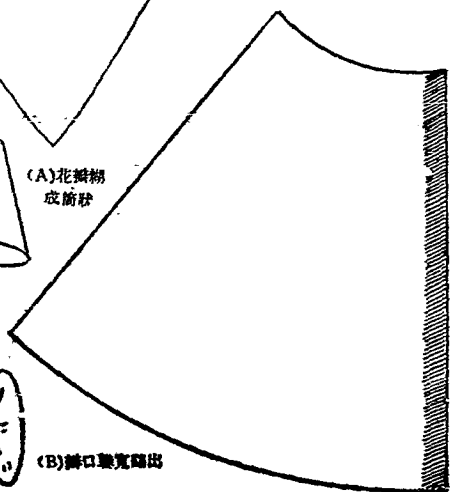

(11) 雛菊

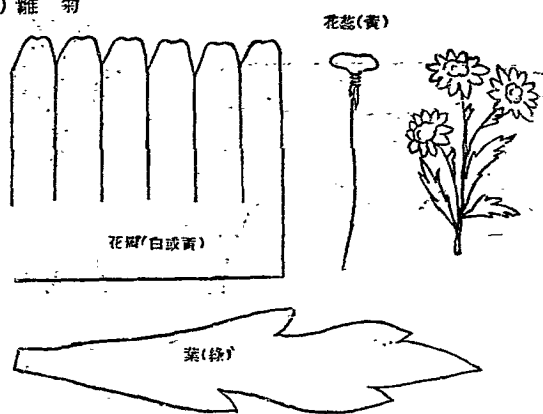

(12) 玫瑰花

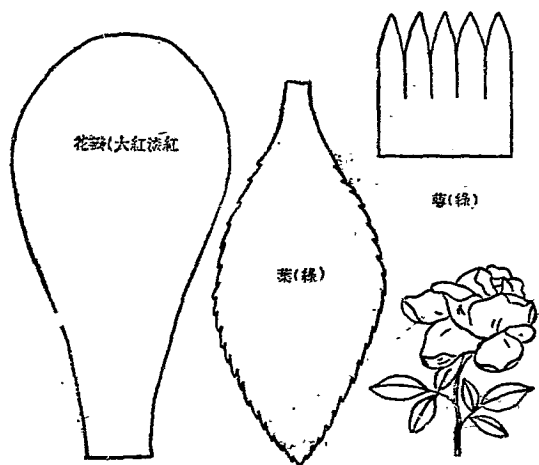

(13) 蘋果花

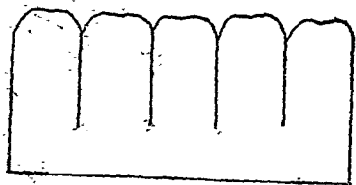

花瓣(白)



葉(綠)



(14) 象牙紅



葉(綠)



葉(紅)

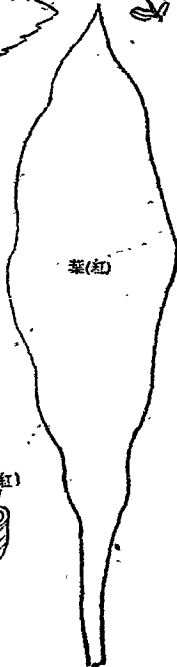

葉(紅)



花心(紅)

(綠)



(15) 菊



花(株)

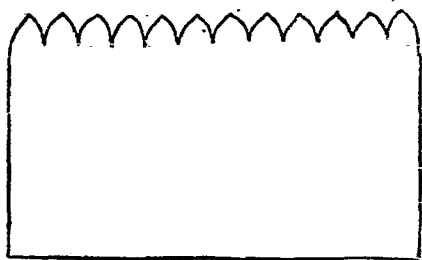

(70)

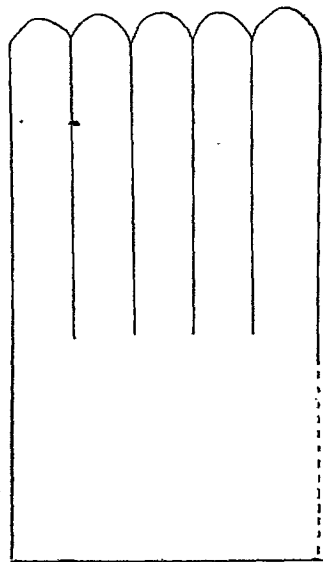

花瓣(黃或白)

(16) 梅花

花瓣(淡紅)

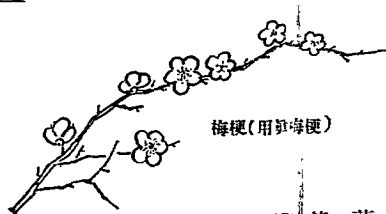

梅梗(用算海梗)

(17) 蒼蘭

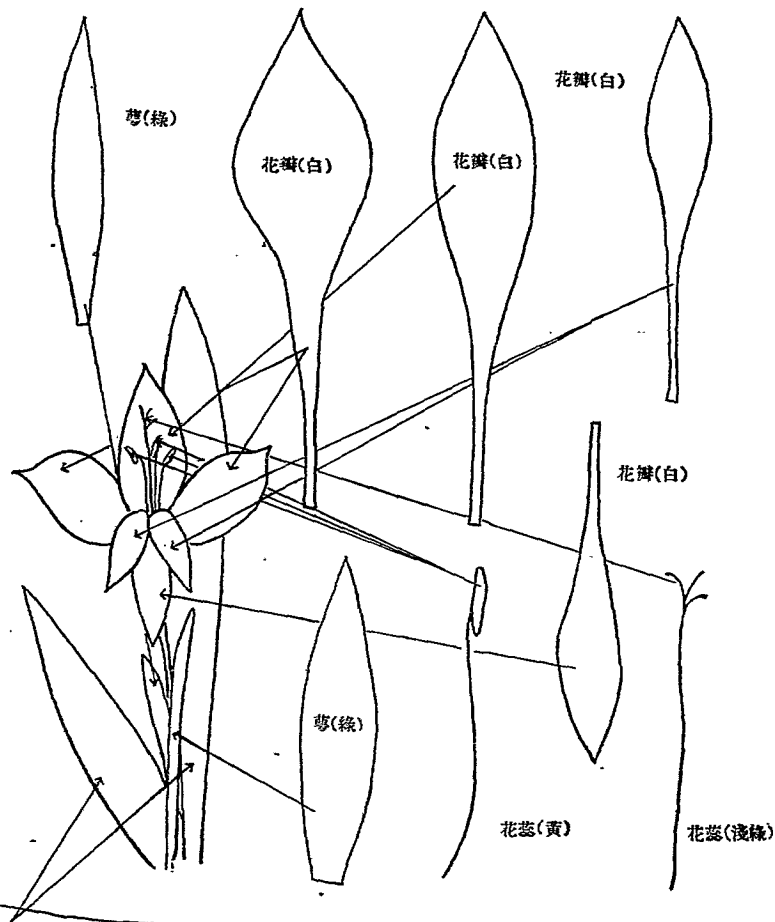

葉(綠)

(20) 長壽花

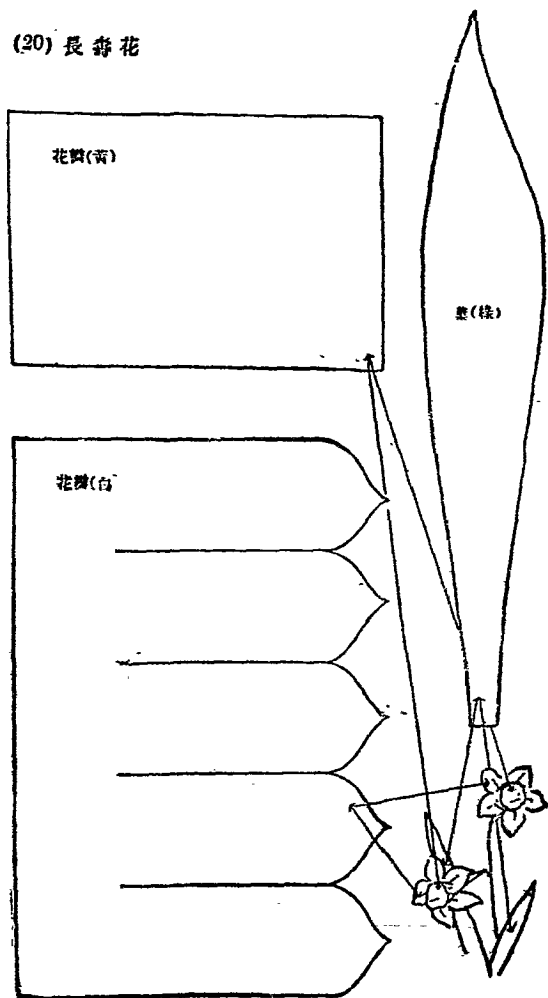

IX

厚紙教材

要旨

厚紙教材最重要之功用，在使兒童發展其簡單的，幾何的，物理的發表能力，並練習其扼要之簡單的，設計的，製圖的，建造的，種種的求形法，剪法，摺法，切法，接合法，裱背法，施色等之技藝。

準備

A 工具 (1) 製圖用具——圓規，三角板，硬鉛筆等。(或代用品)

(1) 圓規

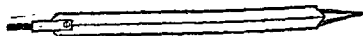

(2) 剪切用具——剪刀, 切紙刀, 玻璃, 同剪紙, 切紙教材。

(3) 塗色用具——塗筆等。

B 材料 (1) 紙料——厚紙, 裱面紙等。(厚紙如馬糞紙等。)

(2) 糊料——漿糊, 膠, 水等, 同貼紙教材。

(3) 塗料——白膠粉, 銀硃, 廣丹, 深黃, 淡黃, 鮮綠, 深綠, 洋藍, 赭石, 土黃, 金粉, 銀粉, 膠水, 廣油等。

方 法

A 工作方法 (1) 設計

(2) 製圖——用製圖用具, 依照計

劃製圖。

(3) 剪切——按照圖樣剪切。

(4) 組合——有摺線處摺疊。組合用牛皮紙，蘸上糊料，在合縫處黏貼。

(5) 糊裱色紙或塗色——將已製成之物品，用糊料糊裱色紙 或用白膠粉塗上，待乾，再用粉質顏料，加以膠水，或廣油，調合塗上。

教 材

此項教材，適用於小學中級高級。關於材料識別，來源，價格，的調查，研究，以及 製品之用途，此類工人生活狀況，均可當作教學資料。



(1) 中式信封(用紙料見樣稿教材)

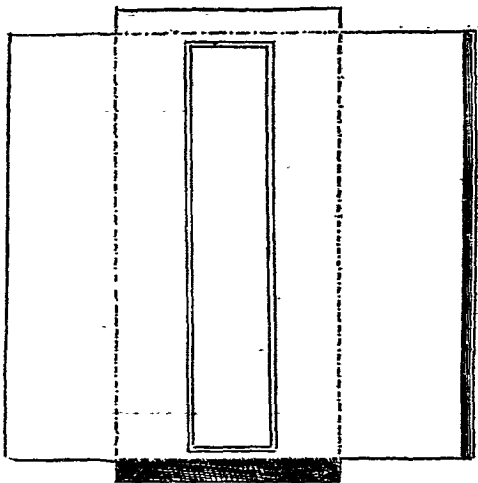

(2) 西式信封(用模造紙或布紋紙)

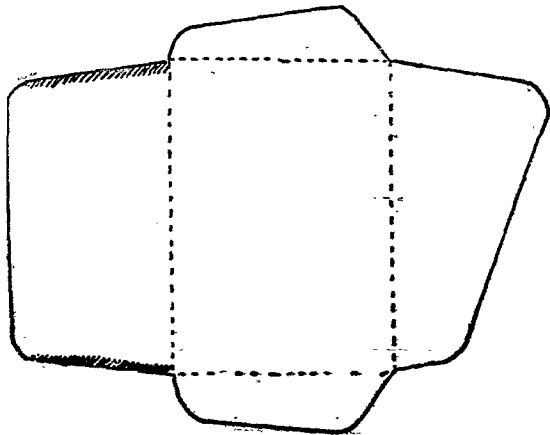

(3) 糖菓盒(用色卡紙)

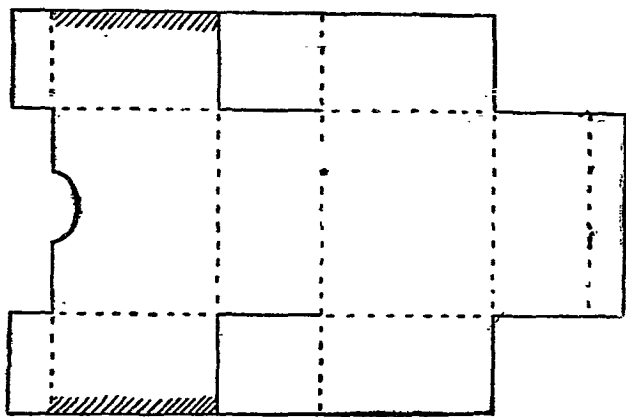

(4) 糖菓袋(用牛皮紙或雞皮紙)

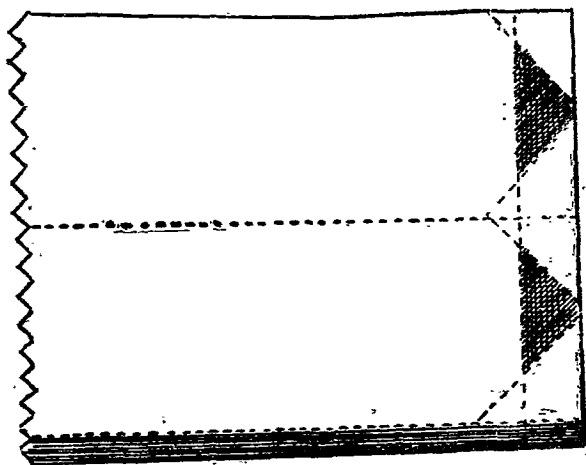

(5) 寫字樓襯版(底版用馬糞紙包角用漆布或印花布)

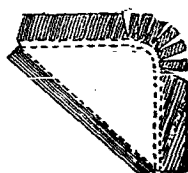
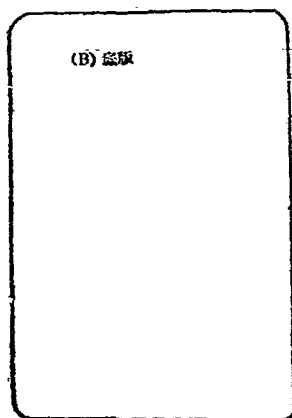

(A) 布角

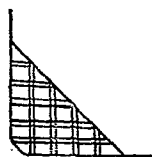

(6) 七巧版(用馬糞紙做外裱色紙)

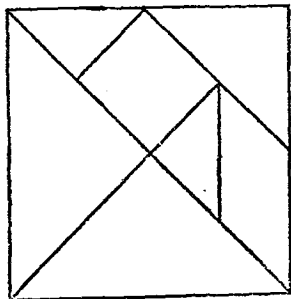

(7)

排
色
版

(材料同上)

(A) 照樣三十二片每四片一色



(8) 活動七巧版(材料同上)

(A) 正面貼法

(B) 背面貼法

(C) 糊成後之活動七巧版

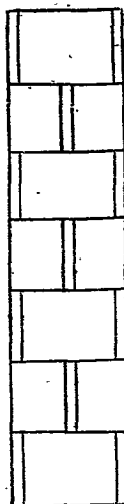
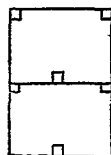
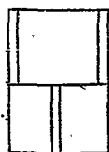

(9) 小寶寶的坐椅(材料同上)

(A)

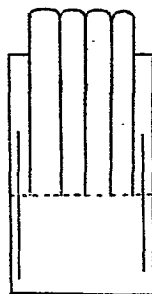

(B) 照樣二片



(10) 小寶寶的桌子(材料同上)

(A)

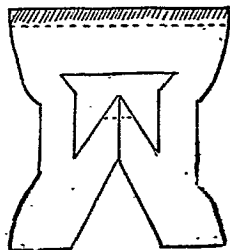

(B)

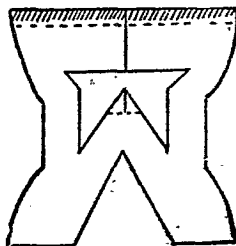



(C)



(D)

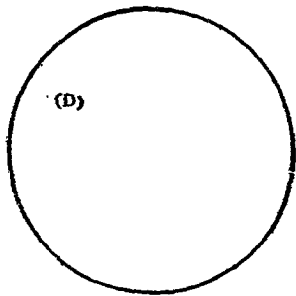

(11) 小宝宝的床

(用马粪纸做外裱色纸)

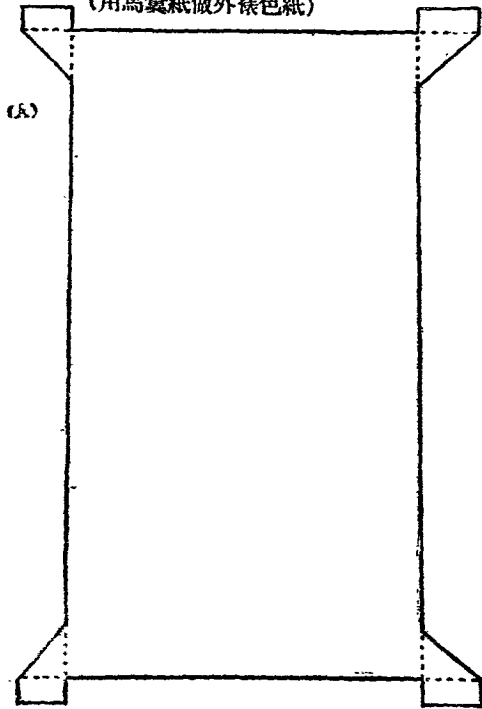



(B)

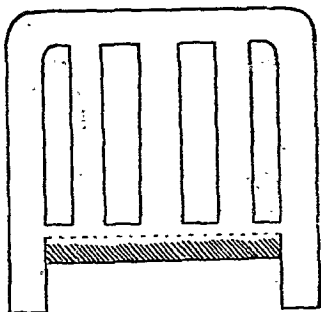

(C)

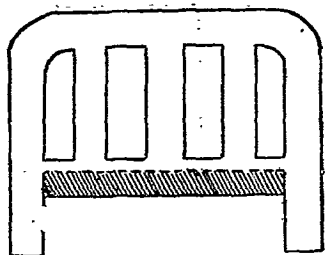

(12) 風 球 (用色卡紙)

(A)

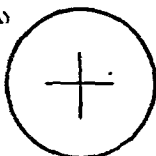

(B)

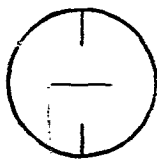

(C)

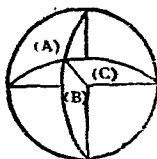
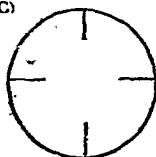

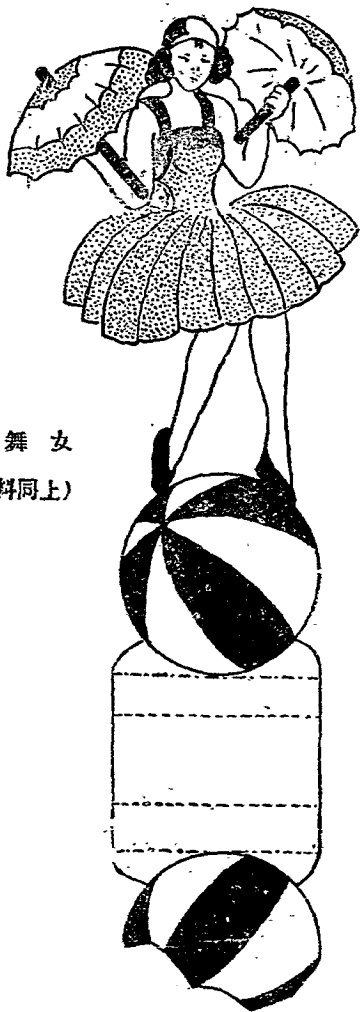

(13) 舞女
(材料同上)



(14) 大力士 (材料同上)

(15) 圓 匣 (材料同上)

(16) 方 匣(材料同上)

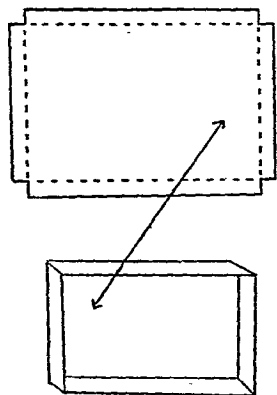

(17) 抽 匣
(材料同上)

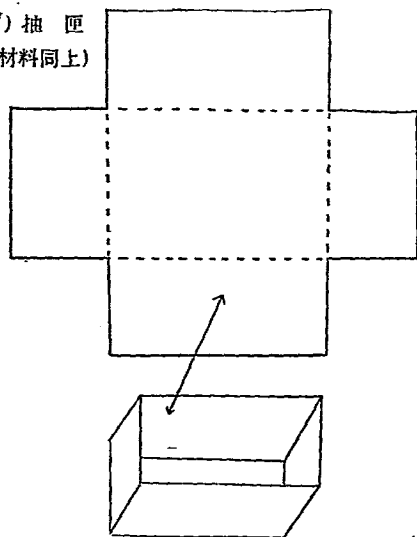

(18) 紙 碟(材料同上)

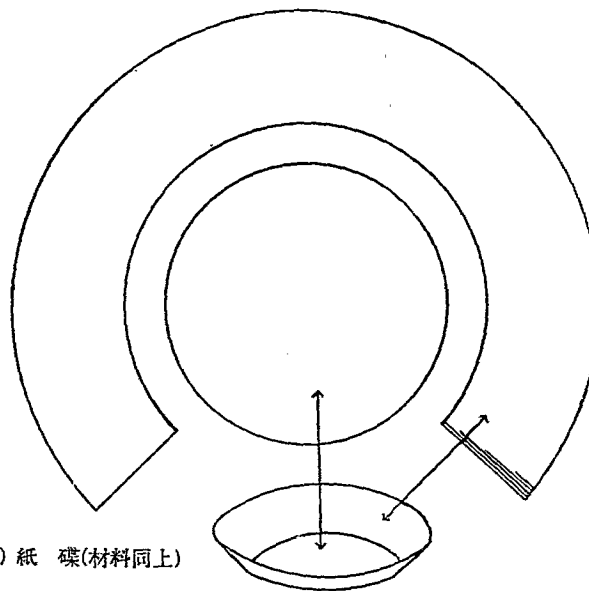

(19) 飛 機(用馬糞紙做施色用塗料或外裱色紙亦可)

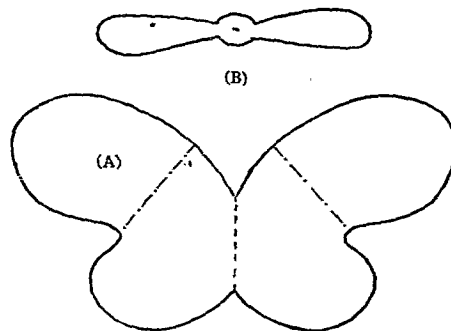

X

印刷教材

要 旨

印刷教材，利用印水，或油墨，印刷紙料的一種教材，裝訂和印刷，因有連帶的關係所以也併入其中。此項工作，對於文化上有重大的貢獻，孩子們也應該得着些簡易的知能，採為教材，頗有價值。

（準備和方法詳見各項教材中）

教 材

此項教材，適用於幼稚園及小學各級，支配進程，以視其印技之繁簡而定。

(1) 印橡皮印

A 準備——橡皮製的動物印，和印水，打印盒，

圖畫紙

B 方法——用印水傾入 打印盒中，將橡皮製的動物印，在打印盒中打上印水，再印在圖畫紙上。

(2) 蓋圖章

A 準備——木質或角質名字圖章，印泥，宣紙或教本。

B 方法——將圖章先在印泥中打上油色，再在宣紙上（用宣紙蓋印時，須預備一襯墊書本，或報紙等。）將圖章蓋印，在自己的教課書，或日記簿上加印亦可。

(3) 型板印

A 準備——鉛筆，及型板，（見切紙教材。）與圖畫紙。

B 方法——用型板攤放在圖畫紙上，將鉛筆在型板的輪廓線四周印畫。

(4) 複印

A 準備——鉛筆，或竹杆，複印紙，襯墊玻璃板及紙料。

~~~~~

B 方法——先將紙料平舖在襯墊玻璃板上，蓋複印紙一層，(復印紙的紙面向下。)繼如前法再舖，可舖上四五層，舖好後，將花樣，或文字蓋在面上，以鉛筆尖，或竹杆，依照花樣或文字印上。

(5)單色陽板噴印

A 準備——噴印陽板。(見切紙教材1—5。)墨汁，噴霧器 紙料。

B 方法——先用紙料平攤在桌上，次以噴印陽板放上，用墨汁注入噴霧器中，向紙料上到處噴射。

(6)單色陰板噴印

A 準備——噴印陰板，(即印花紙板，見切紙教材6—10。)墨汁，噴霧器 紙料。

B 方法——與教材5同。

(7)復色套板噴印

準備——噴印套板。(見切紙教材6—10)廣告畫顏料，或膠汁塗料。(見厚紙

教材。)噴霧器,紙料。

B方法——噴印方法同前,惟第一套色套板噴射後待乾,用第二套板襯上,再照前法噴印之。

### (8)油印

A準備——鋼板,鋼筆,蠟紙,油墨,石油,印架滾筒,及紙料。

B方法——把蠟紙,舖在鋼板上,再用鋼筆在蠟紙上刻印文字,或圖畫。(如須塗改,用火柴在紙上將蠟質燻熱,使其熔化,至筆紋消滅後,再行書繪。)張配在印架上,蠟紙下放置紙料,另用油墨加石油調勻,使薄潤適用,取滾筒滾上油墨,在蠟紙上滾印。

### (9)複色油印

A準備——各色油墨,其他與教材5同惟滾筒須多備數個。

B 方法——方法同前，惟用蠟紙書繪時，須製成套色板。至于套色印法，將套板蠟紙挨次加印于紙料上，略同複色套板噴印。

### (10) 晒印

A 準備——製圖儀器，晒圖架，及打樣紙，晒圖紙，製圖墨汁等。

B 方法——先將製圖儀器，在打樣紙上用墨汁製圖，次將晒圖紙在黑暗處依樣裁切，襯在打樣紙下，同時裝入晒圖架內，放置在日光中晒印。至晒圖紙呈淡綠色時，即迅速取出，入清水中漂洗，至顯出圖樣為止，待乾應用。

### (11) 紙捲裝訂

準備——裝訂紙料棉筋紙鑿子切紙刀

方法——(A) 捲筋紙條

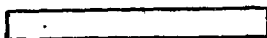

(B) 絞成棍狀式樣(照樣二條)



(C) 照樣用錐子鑽孔

(D) 穿上紙絲

(E) 翻身打結  
三面切齊

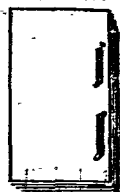
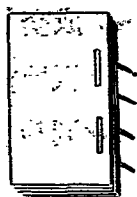

### (12) 鉛絲裝訂

準備——裝訂紙料鉛絲釘切紙刀錐子

方法——(A) 整理紙料照樣摺疊

(B) 放開用鉛絲釘穿上

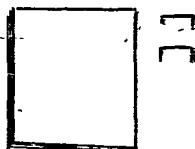
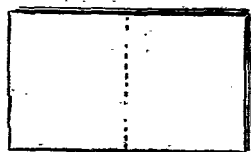

(C) 再照原紋對摺

(D) 三面切齊

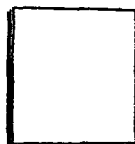
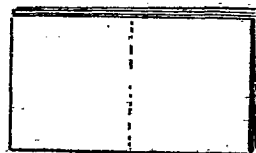

### (13) 銅釘裝訂

準備——裝訂紙料銅釘切紙刀錐子

方法——(A) 照樣鑽孔穿入銅釘

(B) 翻身把釘腳分開三面切齊

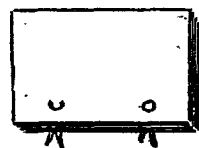

(14) 絲帶裝訂

準備——裝訂紙料打洞機切紙刀絲帶

方法——(A) 把紙料切齊打洞

(B) 穿上絲帶在正面打一蝴蝶結

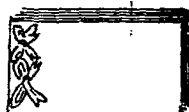

(15) 裝訂中式賬簿

準備——裝訂紙料針線錘子

方法——(A) 照樣鑽上細孔

(B) 照樣用針線裝訂不可有重複線路



(16) 裝訂中式書籍

準備——全上

方法——全上其式樣如下

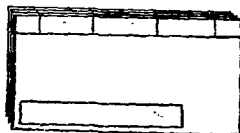

17) 裝訂東式書籍

準備——全上另加糊料

方法——(A) 用針絲如式裝訂

(B) 用糊料粘上封面

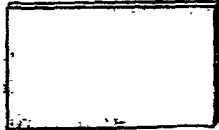
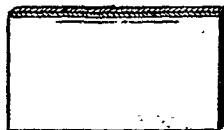



### (18) 裝訂西式書籍

準備——全上封面用馬糞紙外裱色紙或布料均可

方法——(A)照樣分組裝訂

(B)膠合

(C)合裱起來



(D)貼上布條

(E)硬面

(F)照樣加貼

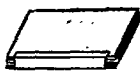

### (19) 活頁裝訂

準備——全上另加絲帶

方法——(A)硬壳

(B)包裹形式

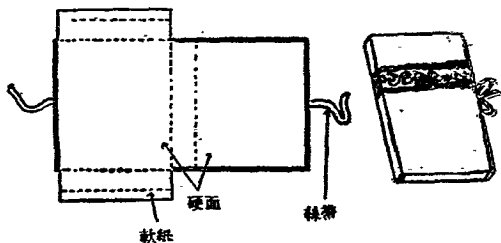

### (20) 凹凸封面圖案

準備——棉織棉布硬紙糊料等

方法——在素製就之硬面底板上加上厚紙型版次以棉布用糊料裱積之再房熱烙露出凹凸圖案

民國廿四年四月初版

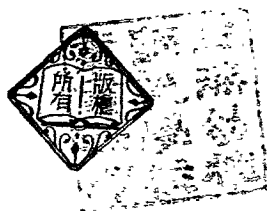

兒童勞作紙工教材

每册定價六角

編者 鄭青騎

發行者 上海幼稚師範學校叢書社

印刷者 大華印局

總發行所 上海膠州路棋榔路潘園  
上海幼稚師範學校叢書社  
分發行所 各大書局

1314

SKB  
MG  
G61  
12