





Class \_\_\_\_\_

Book \_\_\_\_\_

COPYRIGHT DEPOSIT





THE  
STEWARD'S HANDBOOK

AND

GUIDE TO PARTY CATERING.

---

IN FIVE PARTS.

---

PART 1.—HOTEL STEWARDING AND COMPOSITION  
OF BILLS OF FARE.

PART 2.—RESTAURANT STEWARDING AND PUBLIC  
PARTY CATERING.

PART 3.—CATERING FOR PRIVATE PARTIES, AND  
HEAD WAITERS AND THEIR TROOPS.

PART 4.—A DICTIONARY OF DISHES AND CULINARY  
TERMS AND SPECIALTIES.

PART 5.—HOW TO FOLD NAPKINS.

BY

JESSUP WHITEHEAD.

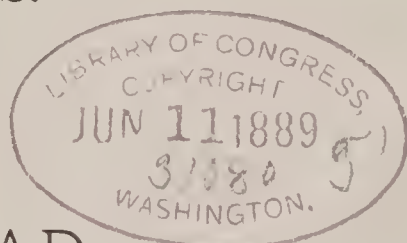

CHICAGO.

1889.

52

T X 921  
.W59

---

Entered according to Act of Congress in the Office of the Librarian, at Washington, by  
JESSUP WHITEHEAD, 1887 and 1889.—All rights reserved.

---

CHICAGO, ILL.

JOHN ANDERSON & Co., Printers, 183-187 N. Peoria St.

# PREFACE.

---

In the preparation of this volume my aim has been to supply just such a book as I wished for myself when I was a beginner in hotel employment and saw how much there was before me to learn before I could reach the paying positions. It has fallen to my lot to be the first to write down what have hitherto been the unwritten rules of hotel management; as the hotel system of this country is advancing and expanding, I have looked upwards and not downwards for my examples; and I beg the reader, who may find some things contrary to his preconceived notions of hotel interiors, to note that I have not made the mistake of imagining that I had to invent a code or system, but have only had to state the facts as they exist already; the expressions of opinion or advocacy of special rules are but the links to make the whole plan coherent, where otherwise it would be broken by the difference in practice of different hotel-keepers. It is due to those who will disagree with me on some points to admit that my friends, the editors, who have published some of the matter serially, found some statements so opposed to their previous ideas they even hesitated to print them; the doctrine which they seemed to think most monstrous is that laid down in "The Steward and His Management of Help," beginning at the bottom of page 23. Perhaps they read it hastily or misconstrued it. Though not too dogmatical to review my own work and reconsider it, I have not, after a year's interval, found a word to change, and have in the same time passed through experiences with two hotel keepers which showed that they, at least, did not misunderstand, and the rule is sound, always premising that the incoming man is a real steward and is competent. It is a formal investment of the steward with his authority that is advocated, the old and efficient hands do not really leave, they are trained to the system and bow and accept the new dictator. The "clean sweep" business is named in connection with corruption and misdoing. Let us suppose a case—or call it reality if you will: A man is sent for by a hotel proprietor to be steward, and the proprietor says: "My help all seem to be unmanageable; they are insubordinate, noisy, quarrelsome, independent, insolent; I want you to change all this; it is injuring my business." The new steward finds a too-good barkeeper, a pet of the proprietor, too, is giving the hands whisky, and this ill-advised liberality with his employer's property is making the barkeeper the most popular man in the house, but is keeping the hands half drunk and unmanageable. All the power the steward has over the barkeeper is to notify him not to treat his hands any more, but that does not help much, for his hands are then sulky and sullen,

his bitter enemies. That is the time for a "clean sweep," or else the steward must back down and leave. In another place it may be a colored girl, my lady's pampered and bejewelled maid, who is the power behind the throne; who orders the cooks and sends the waiters away on errands, and the new steward finds that when he gives his directions the help all look to the pet maid to see whether they are to obey him or not. If the decaying proprietor of such a declining business as this symbolizes wants reform there must be a "clean sweep," not necessarily of the maid, too, but new hands must come in who have not learned to look that way for orders.

In short, I have entertained the idea of writing this book for years past, and made observations accordingly so extensive and thorough as to be able to claim a full preparation for the task before it was undertaken. The interior of a large hotel is not a place of pleasure for the employés. All the heads of departments are autocrats in their sphere if they are good men; if they are bad men they may be tyrants.

In regard to the dictionary, which will commend itself at a glance, it only needs to be said that in the anticipation that it will find a welcome not only among hotel stewards and *chefs*, but among diners-out, *bons-vivants*, club men, restaurateurs, printers who set up bills of fare, editors with gastronomical proclivities, and the polite world in general, I have made it as light reading as was practicable, by embodying the brightest and best paragraphs on every subject in turn by the best writers wherever they could be found. This is the dictionary of that peculiar culinary language, which is not to be found in the regular dictionaries of any tongue, however complete otherwise; it is the language of epicurism and of the table.

Possibly the practice which has prevailed for some time of interpolating poetical quotations in the bill of fare might be improved by the introduction of informatory paragraphs about some special kind of game, fish, or novelty in sweets, turning the attention of those who dine upon one leading feature of the dinner by giving an intimation of its quality, its rarity, its merits, its relation to literature, its origin. Suitable quotations of that kind will be found abundant in this volume. They might be accredited to "The Epicurean Dictionary," which will be fair and impartial to all, for it has been found neither expedient nor even possible to name the authors whose words are placed in quotation marks herein; some of them, it is true, belong to the most famous names, but the greater part are the words of unknown contributors to current literature whose terse sentences offered the briefest explanation of the subjects named.

J. W.



# CONTENTS.

## PART I.

THE HOTEL STEWARD AND HIS DUTIES.—The Steward Out of Fashion —A New Class of Stewards.—Stewards of Other Days.—“The Evil Which Men Do Lives After Them.”—The Pernicious Commission System.—Something Less Manly —A Specimen Letter.—The Steward the Superior Officer.—The Steward Deals Only With the Head Men.—The Steward as Buyer.—The Steward Puts In His Fancy Work.—All Stewards Carve.—Assistant Carvers.—The Steward and the Bill of Fare.—The Steward Who Does Not Know.—The Steward Is the Overseer First and Last.—The Steward as a Worker.—The Steward Manages the Meats.—Stewards Needed Everywhere.—The Steward and the Landlady.—The Steward and the Housekeeper.—The Steward and the Headwaiter.—The Steward and His Adversaries.—The Steward and the Storekeeper.—The Steward and His Store-room.—The Steward and the Care of Meats.—The Steward and His Management of Help.—The Steward and the Hands’ Pay-Day.—The Steward and the Clerks.—The Steward and the Proprietor.—The Inside Steward’s Special Duties.—The Wine-room Steward’s Special Duties.—The Steward and the Dairy.—The Steward and the Dish-room.—The Steward and His Workshops.—When the Steward’s Good Time Comes.—Who Shall Be Stewards?—Promote the Good Cooks, . . . . . Pages 3 to 30.

STOREKEEPING AND BOOK-KEEPING.—How Stores Are Issued and Charged.—Blank Requisitions.—The Storekeeper Must Rise Early.—Store-room Hours.—The Store-room Issue Book.—Example of Written Book (pages 34-35)—Mammoth Requisition List Showing All Articles Needed In Hotels (page 36).—Pastry Requisition of Same House (page 37).—Largest Form of Issue Book and Grand Total of All Departments (pages 38-39) —The Same by a Simpler System (pages 40-41). Changing Cooks in a Large Hotel.—How the New *Chef* Begins His Duties.—The Drinking Habits of Cooks, . . . . . Pages 30 to 45.

HOW TO WRITE THE BILL OF FARE.—The American Hotel Dinner Bill the Standard.—The Hotel Press and Recent Improvements.—Bill of Fare or Menu?—Headings or No Headings?—What Should the Headings Be?—Serving Potatoes With Fish.—Always Serve Fish On Small Plates.—Which First, Joints or Entrees?—Three Royal Examples.—The Place for the Cold Meats.—Current Criticisms.—A Representative Italian Bill of Fare.—The Dinner In Courses.—The Sorbet or Punch.—Those Everlasting Relishes.—Specimen Bill of Fare.—How Many Dishes?—One Soup or Two?—How Many Kinds of Fish?—How Many Entrees?—How Many Vegetables?—How Many Kinds of Pastry?—Conclusions In Regard To the Dinner Bill.—Lunch and Dinner or Dinner and Supper?—How Much for Lunch?—What Sort of Dishes for Lunch?—The Breakfast Bill of Fare.—Specimen Breakfast Bills.—About the

American Breakfast.—A Small Pattern, But Sufficient.—The American Supper or Tea.—Rising Equal to the Emergency.—Combination of Dinner and Supper With Newly Printed Bills Each Day.—List of Dishes for Breakfast and Supper Bills.....Pages 45 to 76.

#### PART II.

RESTAURANT STEWARDING.—Comparison of the Hotel and Restaurant Systems.—The Rise of the Restaurant.—A Typical American Restaurateur.—The Restaurant Steward and the Market Men.—How to “Stand In” with the Market Men.—Keeping Provisions.—A Specimen First-class Restaurant Bill of Fare.—A Few Entrees and a Little Management.—The Merchants’ Lunch House and Bill of Fare.—The Bakery Lunch.—The Place and not the Man.—The Man and not the Place.—The Bar-room Free Lunch.—A Russian Restaurant.—The Oyster and Fish Restaurant and Bill of Fare.—How the Pay is Collected.—The Common Meal Check.—The Written Order Check.—The Hidden Watch System.—The Great American Restaurant System.—The Bouillons-Duval System.—Spiers and Pond’s London Restaurant System, pages 76 to 100. The London Check System.....Page 202. American Hotel Check System.....Page 203.

CLUB STEWARDING AND CATERING.—About Clubs in General.—Party Catering.—Mistakes in Entertaining.—Rules for Party Catering.—Some Exceptions.—Ball Suppers.—How to Set the Tables.—Small Tables.—What to Set Upon Them.—Difference in Cost of Suppers.—Quantities and Qualities.—What Decorated Meat Dishes Consist Of.—What the Ornamental Baskets of Cake Contain.—What the Moulded Ices and Jellies Are.—Setting Long Tables.—When They Dance in the Dining Room.—The Stand-up Supper.—The Bazar Supper.—The Handed Supper.—The Ornamental Handed Supper.....Pages 100 to 117.

#### PART III.

CATERING FOR PRIVATE PARTIES.—Large and Small Catering Businesses.—Lady Caterers.—More Rules for Stewards and Caterers.—Ball Supper for 200.—Provisions and Materials Used.—A Young Lady’s Birthday Reception for 50.—Snow-bound Dinner.—Church Festival.—Club Reception.—Cold Lunch for 300.—Private Reception.—Experience of an English Manager.—Dinners at Various Prices.—Base Ball or Cricket Lunches, Various Prices.—A Quotation Menu.....Pages 125 to 135.

FANTASIES OF PARTY GIVERS.—A Pink Dinner in Washington.—A Yellow Dinner in Boston.—A White Dinner in London.—A Violet Supper.—A Dinner in Scarlet and Black.—A Pink Rose Dinner.—A White Lily Dinner.—A Mermaid Dinner.—Crowns, Stars and Diamonds.—The Plateau.—Changing Fashions in Wine Glasses.—A Figurative Dinner.—A Vari-colored Dinner in Buffalo.—A Tropical Dinner in New York.—Fish Dinners in Paris.—French Dinner Table Decorations.—Imitating Lucullus.—Royal Soup.—The Same Idea With a Purpose In It.—Floral Decorations at President Arthur’s State Dinners.—President Cleveland’s Table.—Floral Decorations at the Princess’ Ball.—Tens of Thousands of Flowers.—Decorated Dishes at Mrs. Vanderbilt’s Reception.—Mrs. Vanderbilt’s Diamond Ball.—The Progressive Dinner Novelty.—The Lady Had a New Idea.—Couldn’t “Call Off” the Entrees.—Notions In Silver.—The Vienna Coffee Fashion.—Different China for

Each Course.—Candles and Glass Shades.—Notions in Ices.—Changing Decorations for Each Meal.—A Boating Club's Fantasy.—Scene Painted Ball Suppers.—Sea Caverns and Fairy Grottoes.—A Sea Shell Dinner.—A Wedding Banquet.—Grand Wedding Receptions.—Wedding Breakfasts and the Prices Charged.—Eight Specimen Menus.—Something About the Cost.—Ten Dollars per Plate.—Five Dollars per Plate Without Wine.—Six Dollars With Wine at the Café Royal.—Two Dollars Without Wine.—A Ten-dollar Meal for Five Dollars.—Dinners at Thirty Dollars.—Temperance Catering.—Topsy Fruit at a Temperance Banquet.—Prohibitionists and Fashionable Cookery.—Too Rich for His Blood.—Sarcastic, But Suggestive.....Pages 135 to 157.

STEWARDING AND CATERING ON A GRAND SCALE.—Stewarding at Harvard University.—At Vassar College.—At Windsor Castle.—At a Penitentiary.—Steamship Stewarding.—Purchasing for a Large Hotel.—The American Game List.—Lunch for 5,600 people.—The American Clam Bake.—How It Is Done.—The American Barbecue.—The Improved Barbecue.—The Primitive Barbecue.—An Electric Lighted Barbecue.—How an Ox Was Boiled Whole.—The Number, Weights and Price for 3,000.—The French Governmental Banquet to 3,000 Mayors.—A Railway Eating House in Sweden.—Breakfast for 10,500 people.—Catering at the Manchester Exhibition.—How 30,000 Children Were Fed.—Catering for the Multitude.—Stewarding for the Sultan.—The Army Hospital Steward.—Exposition Catering.—Catering at the Piedmont Exposition.—Training a Storekeeper.—The Store-room Stock Book.....Pages 157 to 184.

THE HEADWAITER AND HIS TROOPS.—The Headwaiter.—The Headwaiter's Importance.—The Headwaiter Does No Waiting.—Scarcity of Good Headwaiters.—The Foreign Headwaiter.—In American Hotels.—Organizing the Troops.—Waiter's Uniforms.—Telling Off the Watches.—Watch On, Watch Off.—Let the Headwaiters Tell It.—Another Headwaiter Talks.—What the Dining Room Chief Talks About.—Waiters Drill for a Banquet.—Who Are the Best Waiters?—Waiters' Wages and Tips.—Cherubs at the Hotels.—Rough on the Waiters.—London Waiters.—Paris Waiters.—Discipline in Paris Restaurants.—Accommodating Waiters.—Tricky Waiters.—Berlin Waiters.—A German Baron Waiter.—How Waiters Fight Duels.—Female Waiters.—New York Waiter Girls.—A Dining Room Juno.—The Pennsylvania-Dutch Waitress.—The Mischief of Pretty Waiter Girls.—Girls on a Strike.—Another Strike of Waitresses.—Respect Instead of Money.—Colored Waiters.—Troubles Common to All.—The Tyranny of the *Chef*.—Another Trouble.—A Few Types of Waiters.—Just a Plain Waiter.—A Waiter's Valentine.—A Waiter's Wife.—A Treasure of a Waiter.—Waiters' Christmas.....Pages 184 to 218.

## PART IV.

IN THE DICTIONARY OF DISHES will be found under the respective letters — Consommés.—Drinks.—Egg Cookery.—German Cookery.—Greek Cookery.—Ices.—Italian Cookery.—Jewish Cookery.—Mexican Cookery.—Oriental Cookery.—Potages.—Sauces.—Soups.—Spanish Cookery.—Scottish Cookery, Etc., Etc.....Pages 219 to 464.

## PART V.

SERVIETTES AND HOW TO FOLD THEM, fully illustrated, Appendix, .....Pages 1 to 29.



# THE STEWARD'S HANDBOOK.

PART FIRST.

---

## HOTEL STEWARDING

SHOWING THE INTERNAL WORKINGS OF THE AMERICAN  
SYSTEM OF HOTEL KEEPING.

---

### THE STEWARD'S DUTIES

IN DETAIL AND IN RELATION TO OTHER HEADS  
OF DEPARTMENTS.

Steward's Storekeeping, Steward's Bookkeeping,

AND MANAGEMENT OF HELP.

ALSO,

*COMPOSITION OF BILLS OF FARE,*

THE REASONS WHY, AND NUMEROUS ILLUSTRATIVE MENUS  
OF MEALS ON THE AMERICAN PLAN

---

BY

JESSUP WHITEHEAD.

---

CHICAGO.  
1889.



## THE HOTEL STEWARD AND HIS DUTIES.

---

The steward is out of fashion just at present, although there are indications that the time is coming around again when he will take his proper place in the hotel economy, a place second in importance only to that of the proprietor. He has been dropping out of fashion more and more every year for a long period, while the *chef* gained the ascendancy, till now the steward and his position are almost forgotten. It used to be sufficient to say that Mr. So-and-so was the proprietor and Mr. Somebody was his steward, and that included everything, for the steward had *his* headwaiter, *his* cook, *his* pastry cook. Some stewards of the few remaining write *my* cook, etc., yet, from the force of old habits, but really there are but few and they are but seldom heard of. There are plenty of indications to satisfy anyone that this is the case. There is no employé of any importance about a hotel or restaurant so seldom mentioned in print now as the steward, and if one of them does appear in print through his own writing, he gets but a nod like any stranger, and at once disappears. It is very rarely that any advertisement appears of a steward wanted, and when occasionally a steward advertises for a situation it is half-heartedly, for most of such advertisements end with an offer to assist with something else, as if it was scarcely expected that any hotel keeper could possibly want a steward, or as if a steward's duties were not exacting enough to demand every minute of his time; some, who so advertise, have been stewards, they say, twenty years or more; that is, they are of the old stock of stewards, remainders from the stewards era, and cannot help offering themselves. But the young men

who advertise numerously wants to be assistant managers, managers of small houses, caterers, occasionally, or store-keepers and assistant clerks, anything but steward, and letters of inquiry come to the hotel newspaper offices innocently asking what the steward's duties are, almost by implication asking what stewards are for. About a year ago some newspaper man interviewed the proprietor of a large hotel in Washington and asked him about the methods of internal management, and asked: "How do you know how much to cook?" "I confer with my *chef*," answered the proprietor—and then we do thus and so, and the dialogue included many such questions. But where was the steward in that case?

Another such indication comes to hand in a very late number of the *Hotel World*, after the foregoing had been written, and must be repeated for its worth and to help confirm the position taken, that the steward is out of fashion, and the *chef* is in the ascendant:

The *chef* of a large Saratoga hotel is reported as saying: "We receive word from the office every morning how many people there are in the house, and there are certain well established rules for calculation. For instance, among a certain number of people so many will take roast beef, and we have found by experiment that 100 people require a side of beef weighing about forty pounds. Among the same 100 people forty or fifty chickens will be needed, according to the size of the chickens. We can calculate pretty closely, but we have to be liberal, so that if fifty or sixty people come in to dinner whom we did not expect, there will not be a scant supply. I make

out the bill of fare for each day's dinner on the afternoon of the previous day. I look over my stock, ask the steward what he expects to have in by the morning trains, and thus knowing the material I shall have to work with on the morrow, the bill of fare is made out."

The above is according to fact, but if everything in the hotel system were in its proper order it would have been the steward who did the taking, conferred with the cook, instead of being questioned by the cook, and who would have suggested the bill of fare and revised it after the *chef* had written it.

A year or two ago a young proprietor in sore trouble applied to the writer to assist him in finding a different variety of cooks from those he had met; he said he had tried all sorts, the high-priced association cooks among the rest, and he stigmatized them all as a man will who is tormented. He wrote: "I want a cook who can compute the cost of his meals, who knows the difference between skillful work and common extravagance, who will remain at his post until the meal is over, and be as willing to earn his wages as I am to pay them." This young proprietor has come into the business while stewards are out of fashion, and it never occurred to him that what he really did want was a steward. There are no cooks who will do all that he sees should be done, none that have learned to compute the cost of meals, except with the coöperation of the steward and store-keeper; where there is no steward something is neglected to be done. Although this necessary officer may be absent, his duties are there to be performed in every hotel, and are divided amongst several, and as these cannot do as well as a man trained to the special duties of the position, there must necessarily be irregularity, incompleteness and loss in the hotel system.

#### A NEW CLASS OF STEWARDS.

If there is to be a new beginning, if the steward is to catch up with his proper place in the line of hotel improvement, so that

he will be found where he ought to be in every hotel, and if it is become so that the steward will be engaged first and the cooks at any time afterwards, instead of the present general practice, there must be a model for young men to build upon. It is impossible now to give a satisfactory answer to the inquiries that are received as to what constitute a steward's duties, for it is too indefinite a question. There are two different sorts of stewards at present filling the positions where they are filled, and one of these types will endure and be *the* hotel steward of a few years later, and then his duties will be well defined. One of these is the New England steward, the other is the New York steward, which is the same as the ship steward and the Southern steamboat steward of years ago. Nothing invidiously sectional is meant by the adoption of these distinguishing terms. There are New England stewards in New York and stewards of the New England type; they are the men who go from the North every winter to take the same positions in the same Florida hotels year after year; not all of them are of New England birth, some are Canadians, or of more distant origin still; when by chance they have to advertise for a position they describe themselves as working stewards. And there are stewards of the nautical New York type in New England (for New York is but the rendezvous for steamship men and steamboat men), the bossing and buying stewards, who are officers and used to discipline, yet absolute in authority in their own department, and fine men in their own sphere; yet, somehow, they do not assimilate with the hotel system; neither do they who learn from them. Proprietors, after a trial, prefer to carry on their business without them, and the steward drops out of sight. The kind of man that is coming to the front is a bossing and buying and working steward, too. He knows what should be done, how it should be, and sees that it is so, and when there is any necessity whatever for him to do so he can take hold and do it himself.



A more efficient set of men, who yet do not suit the hotel system, cannot be imagined than the stewards of the ocean steamships and old-time, long-trip river steamboats. They have entire charge; the passengers must look to them for everything and not to the captain, who is but a court of appeal, a higher authority in reserve. When complaint is made to the captain he is very apt to say, "Sir or Madam, I have a steward who manages all those matters, he will arrange those things to your satisfaction, you had better speak to him." If a polite commander, and desirous of pleasing the passengers, perhaps he will promise to see the steward about it himself; beyond that he does not interfere, and for good reason, for he has other cares and duties, those connected with the cargo and with navigation. These stewards are everything to the passengers; the head waiter is second steward; his next best man is third steward, and it is no wonder if all the waiters come to be called stewards in such a case, as they are on some steam vessels; and this practice has had such effect that anywhere south and southwest from Washington and Baltimore the native hotel proprietors call their head waiter their steward, and when they engage a steward they expect he is going to take charge of the dining room and waiters, if not wait on table himself. But these efficient steamship and steamboat stewards are not suited to even the modern hotel, because the proprietor must have something to do, not having any cares of cargo and navigation on his mind, and if such a steward exercises his full function he becomes the big man and the proprietor the little man of the house. There cannot be two kings over one small kingdom; one of them has to abdicate. The proprietor cannot and does not deny that the steward is right about his duties and prerogatives, but he does a quieter way, concludes that he does not need a steward; will perform part of the duties himself and puts the other part upon the *chef*.

## STEWARDS OF OTHER DAYS.

Those old-time Mississippi steamboat stewards were fine models of executive ability; they were remarkable men in their way, and are worth a passing description, for we shall never see their like again; the same state of their business will never exist again, for they were without the telegraph, practically without mail or express, since their boat carried the mail and they could hardly send word ahead, and the express reached only the railroad points which were limited then to the northern cities. They were models for the summer resort steward whose hotel is off the regular lines of travel, in a difficult country, destitute of local markets and with slow and uncertain means of communication. Indeed those stewards were generally resort men themselves, for the boating season was in winter and spring, and the best of them had summer engagements at the various fashionable "Springs" to pass away the time when the rivers were low and the crops were not ready to be moved. These stewards had entire charge and control of the victualling department and hiring of help and rate of wages to be paid. The captain held but one powerful restraint upon them; he and the chief clerk, who was the cashier and paymaster, kept up a rigid comparison of the bills for each month and for the same months of former years, and, in a general way, the steward who could run the boat with the smallest monthly bills was the man they wanted for that position. While this fear of running up a monthly expense account that the captain wouldn't stand, was a great check upon the entire steward's department, the men who were smart enough to be stewards were fertile in expedients for dodging a direct comparison, and often made their dearest months seem the very contrary, either by collusion with the merchants or by special excuses plausibly presented. The captain did not know the waiters nor whence they came, nor did he know the cooks, unless by chance he had one of some repute, but if this steward required twenty waiters and seven cooks

and another could run the boat with fifteen waiters and five cooks, the cheaper man had the better chance of the position. These are the same checks and balances which hold good in the hotel of to-day, and everywhere, but there were other checks in the thorough first-class steward's favor, for the captains were desirous of a good reputation for their craft and had rivals in the business, and the dearer man often had his day to be on top regardless of expense. Where the special ability of this class of men was best shown was in the provisioning of the boat in advance, and so managing that every succeeding day's dinner would be better than the last, and the last dinner of the trip was complete with every luxury of the season, although it might be seven or eight days since they left the city and the markets, and there was always a degree of uncertainty as to how many passengers might come on board at the various towns and landings of a ten or twelve or fifteen hundred mile trip. The boat's crew of deck hands and firemen, amounting to anywhere from twenty to sixty or seventy men, were also provided for by the steward, and calculations for them had to be made as well as for the cabin, just as the hotel steward has to provide separately for a large portion of "the help."

Going down stream they left orders at certain landings for the boat storemen to have so much milk, chickens, eggs, or such things, ready by a certain day on their return; for the rest the trusted to their well-managed ice-chests and store-room. The steward hired the stewardesses, who is the same as the hotel housekeeper, and she generally hired two girls to help her. The steward, likewise, hired the porter and barber, but had nothing to do with the bar-keeper, nor engineers, or mate's crew. There was a pantryman, who did not wait at table; the fifteen or twenty waiters were divided into berth-makers (instead of chamber-maids), lamp-trimmers, knife-cleaners (for plated knives had not yet come into use), napkin-folders, and the usual side work, and they filled in all their time be-

sides in scrubbing paint, except the short interval in the afternoon.

These waiters had to carry all the stores on board from the wharf, whether at the city starting point or at way landings, so that the steward and those he hired and controlled carried on the entire hotel department of the boat without aid or interference from anybody. Steamboats are still running under much the same rules. This is spoken of in the past tense, because it refers to a time when the passenger trade was so good that the steamboat table was as good as money and skill could make it, and the time on each trip was long enough to make the steamboat more like a hotel in some out-of-the-way place than the lightning-express boats of to-day can possibly be; and, besides the best of their time was from ten to twenty years B. W., which means before the war. So, presumably, those old-time stewards are all dead and cannot object to the statements contained in the next chapter.

"THE EVIL WHICH MEN DO LIVES AFTER THEM."

These men, these old-time river stewards, are largely to blame for the fact that there are so few stewards now in the hotels. Their standard of morals was generally very low; they were sharps, they were universally "on the make." When the passenger trade was taken away from them by the building of railroads they naturally went into the hotels, where they were not adapted to remain, the hotels being generally not large enough to hold them and not wealthy enough to stand the "bleeding" which the river steward could not live without resorting to.

About five years ago a party of four or five old survivors met together talking, and a number of young hotel boys sat around learning steward wisdom as it fell from their lips. Said one:

"What! Don't you know how it was we river fellows never could make a go of it in a hotel?"

"No; what was the reason?"

"Landladies!"

And then he brought his lips together, bulged out his cheeks, and looked around as if that one immense word was all that need be uttered. Soon he resumed:

"You know there's no landladies on the boats and—oh, well," with a shrug, "in the hotel pastry room and kitchen you don't see the difference, for they don't go there much, but we are all about the house and so are they, and when we go to run it right we step on their toes every once in a while."

"Well," said another, "I got a pretty good 'sit' in there at the St. James, and never quite knew how I got out of it, but *somebody* must have been meddling. You know I was on the N—— No. 2 and on No. 3; they both burned up, and then I went and brought out the new No. 4, but there was no water that season and she couldn't run; so Captain C—— took me over to the St. James and gave me an introduce, and I went as steward of the house, and I made up my mind that was better than a boat and I could keep my family cheaper. There was my buggy ready for me at five every morning to go the rounds of the markets, and I would go to the butcher's and pick out what I wanted for the day, and I would pick out a roast for myself and order that sent around to my house when they sent the wagon with meat to the hotel; then down to the fish market and vegetable market and do the same. Then I drove back to the house and when the stuff came in I weighed it, footed up what I had bought, took the bills to the office and they handed me the money to go and pay them with, for they paid cash on the nail every day, and after breakfast I went around again and paid for everything received that morning. Every week or two I would say to the butcher, 'Well, what do I owe you for what you have sent to my family?' 'Oh, nothing,' says he, 'that's all right,' and not one of the others ever charged me a cent, either, and I was getting along as good as you could expect of a hotel; but *somebody* must have been meddling, for I had a little unpleasantness in the office and I quit."

Then another took up the conversation: "We hadn't such a bad time with those boats when the seasons were right, with plenty of water in the rivers. A fellow had to be in with the boat store-men and then he was all right, for they could get him a berth if he got out, and would pull him through a hard time. Yes, they were a clever lot of fellows. I used to stay around with old Tom Curtice and son at Vicksburg, and I've seen the time when it was pretty hard to pull through from one season to another, I tell you, but whenever I went to Curtice he would say, 'Well, Frank, how is it now?' 'By jing,' says I, 'it's pretty tough when a boat's so long coming out.' 'Well, Frank,' says old Tom, 'what do you want, what can we do for you; all you've got to do is to say it?' 'Well, Mr. Curtice,' says I, 'about twenty-five dollars to pay house rent is the size of it.' Then without another word he would turn to his son and say, "Richard, open the drawer and hand Frank twenty-five dollars—no, give him thirty, he can use it,' and that's all there would be about it. It might be months afterward, but sometime I would say, 'Mr. Curtice, how about that thirty dollars I owe you?' 'Oh, don't name it,' says he, 'you don't owe us a cent; but how many tierces of ham, bacon, shoulders and lard shall we send aboard this morning?' 'Well, it was to their interest to be clever to us and they knew it. The captain was stuck on having all the stores purchased in New Orleans, but in the first place it was not his business where I got my stores, as long as the price was right, and then it was the easiest thing in the world for me to forget, or have it come from the New Orleans house late enough to miss the boat, and have to take on stores at Vicksburg, anyway."

Such are the favorite topics the old-timers love to converse upon and the hotel boys think they are learning from them how to be stewards.

One year ago one of these same young men, who listened for hours to the talk of the party above named, was met by the

writer in the South. In the interval he had been steward, or part steward, in a hotel in a town on the Hudson, and what he told of his experience showed that the lessons in stewarding, he had listened to, were not thrown away upon him.

When met he was the roast cook in a large hotel at forty dollars per month, and in answer to the question how he was getting along, he replied:

"Oh, I made the worst sort of a break for myself when I came down here. I had a good little house up in York State; I was *chef*, but the house did not keep a steward and I did the buying for them, and was doing very well, but I kicked because they would only pay sixty dollars. But if I had looked at it right that house was worth a hundred dollars a month to me, every cent of it, and it was a small house and I didn't have to work hard."

"But how was it worth a hundred a month to you?"

"Well, for one thing, I was sure of a five dollar bill from the butcher every Monday morning, and all the others I traded with chipped in a little. Then I made the waiters whack up to me; they got money and they had to divide or would not get anything. Then at Christmas time I got a new suit of clothes, a pair of fine boots and a fine hat and they never cost me a cent; but I kicked on the sixty dollars and they got somebody else and I quit and came down here."

And so the young would-be stewards are cut down like the green grass and the race is in danger of becoming totally extinct.

#### THE PERNICIOUS COMMISSION SYSTEM.

The very fact that these old-school stewards and the young fledglings who think they are learning the steward's duties from them, relate these money-making experiences with so much gusto, and, indeed, make them their favorite subject of conversation, shows that they do not consider bribe-taking dishonest. It may be their moral sense is very dull, but if they need

to justify themselves they can find abundant excuse in the prevailing system of per cents and commissions. There is not a thing that must be purchased from a merchant but bears two different prices: the list price, or asking price, and the net price. From the material to build the hotel, the furniture, ranges and crockery, to the type to print the bill of fare, everything comes priced at so much, but with five, ten, fifteen or twenty-five per cent. off to the actual purchaser, and if the old-school steward is allowed to be the purchaser there is no possibility of convincing him that he is not entitled to that commission, and, furthermore, according to his reasoning, if the distant merchant do so unsolicited the home merchants must be made to do the same. And the home merchant who wants his trade agrees with him, and, more than that, says to him, "You may as well take the commission; if you don't somebody else will, and if not the house will not get the benefit; the price will be the same and we shall keep the commission ourselves, as well as our regular profit."

The writer knew a youthful cook in a large hotel, only a few months ago, who went to the office and asked the proprietor to send for a list of knives and tools for him and take the amount out of his current months wages. The proprietor did so. The bill of goods was in the neighborhood of twenty dollars; there was the usual discount allowed and it amounted to about three dollars and a half. The proprietor, who was a mercantile man himself, charged the cook the full list price and put the purchaser's commission in his own pocket. This made the youthful cook, and probable future steward so "mad" that he would have discharged the proprietor if he could, but as he could not he tendered his own resignation instead. Yet this is what the old-school stewards think is the right thing to do. Human nature is the same in proprietor as in cook, and when the steward pockets the commissions which he ought to obtain for the house and not himself, the proprietor may not split logic over

it, but he is liable to come to the conclusion that he can get along better without a steward, and if the butcher is making so much profit that he can afford to give five-dollar bills to his customers, the proprietor will go and receive his share himself. The coming steward will refuse to take these bribes for reasons apart from the question of morality and the correctness of prevailing commercial customs, but from another motive, to be dwelt upon further on.

#### SOMETHING LESS MANLY.

While these old-time stewards took such extreme pleasure in talking over the delights of commissions and per cents, there was another source of profit worked by some of them that was never spoken of. They were generally a rugged and manly set of men, used to controlling others, and perhaps were conscious that there was nothing to be proud of in this sort of brokerage. It was the selling of the situations under them. None can know whether the practice was general or to what extent it prevailed, but it was well known that the situations on some boats could only be obtained by purchase. The stewards kept up communications and knew where every available porter, second steward, stewardess, cook and baker could be found, and if the old hands were not coming back some such trades as this took place. The boat paid a certain price for each employé, the rate being fixed by the stewards themselves, and no man or woman was wanted, or could ever afterwards obtain a situation, who would offer to come and take less. The stewardess (housekeeper) was required to be a respectable, matronly sort of a woman, one whom the lady passengers could feel at home with; the wages for such was usually forty dollars per month, but she did not secure it all, having to pay part of it to the steward. In the case of a cook the trade would be about like this:

Steward—"This boat pays eighty dollars; what will you give me for the job—will you pay me twenty dollars a month for it?"

Cook—"No, I will pay you ten dollars a month."

Steward—"You can't have it. But you want to work?"

Cook—"Yes, I want to work."

Steward—"And my friend up the river writes me that you are a good cook; now, I like my cook to be a good one if he does not cost me too much—I'll split the difference; you shall pay me fifteen dollars a month for the job, pay every trip before you go ashore."

Cook—"All right, I'll do that."

Steward—"Well, pull off your coat and go to work; I'll go and enter your name on the cashier's book."

But the cook generally had the privilege of hiring and discharging his kitchen help, and could partly recoup himself by selling the second cook's job in the same way.

It must be said in their favor, however, that the majority of river stewards thought this a despiceable practice. "Why," cried one of them with intense scorn, "a man aint fit to be a steward that can't beat his hand out of all their money at cards. That's the way I always do, and it is more honorable than grinding them down; what is the use of making small dickers!"

#### A SPECIMEN LETTER.

The mixedness of the ideas of a steward's duties contained in the following letter is easily accounted for when the fact is taken into consideration that there are two different types of stewards now doing business in the hotels of this country; one set does and the other does not do as the writer says. After discussing the matter from their different standpoints we will endeavor to draw some definite conclusions and outline the duties of the coming steward. This letter is from New Hampshire; it is written on paper bearing the imprint "Kearsarge" hotel; it is one of the best specimens of a letter of inquiry of this sort ever received, for the writer has ideas of his own and starts the subject, and the italics, which are his own, intimate very

clearly just what points were in dispute. It runs:

"Having some dispute with friends in regard to the duties of a steward in a first-class house I told them I would leave the matter to you to decide as I knew \* \* \* \* I told them that the steward engages *all* the help for the kitchen, the *chef* included, also headwaiter (the waiters under the headwaiter may be hired by the headwaiter subject to the steward's approval), and that all the above help are under and subject to the steward's control; that the steward does all the buying of supplies for the table and all kitchen utensils; that the pastry cook or confectioner makes all ices and creams; that the steward does *no* carving, as that is done by the cook or his assistants; that the steward gets up *all* bills of fare; that it is *not* his duty, or his assistants', to carry from the carving room and care for the meats, etc., that may be left after the dinner is over, that duty belonging to the cook; that the steward does *no* manual labor, but is the head and director of *all* matters pertaining to kitchen and dining room; that the steward's *assistant prepares* all meats for cooking, but *not the steward* personally.

I have been interested in small hotels, not large enough to employ a steward, and so may be wrong in my statement, and if so will you please give me the correct duties of a steward, and oblige, etc."

#### THE STEWARD THE SUPERIOR OFFICER.

The first proposition is only partly right, the steward hires the *chef* or head cook but not the kitchen help under him; the steward hires the headwaiter but not the waiters under him; the steward hires the baker, pastry cook and confectioner but not their helpers—not by right, but he frequently does in fact as a matter of accommodation because he knows where to find them when the cooks themselves do not, and the steward always has the power to discharge any hand for disobedience or misconduct, or to suspend or fine him.

The steward is the superior officer over

the head cook, over the headwaiter, over the pastry cook and the rest. He is next to the proprietor. He is responsible for the good or bad table that the house sets, and for the quality of the service. If he does not have the power to hire or discharge the cooks they will work against him and there will be no harmony; they will look to the higher authority, blame the steward for the poor quality, real or alleged, of the supplies furnished to them, and make of him little more than a market man and messenger, and the headwaiter will take but little notice of the complaints the steward may hear and report to him concerning his waiters' conduct, if he knows that the steward has no power except to talk.

#### THE STEWARD DEALS ONLY WITH THE HEAD MEN.

But the head cook has his own favorite second who goes with him year after year, and frequently his roast cook and broiler and several others whom the steward never exercises his authority over, except when they wilfully transgress his rules, and rarely ever speaks to, for whatever they do wrong or right the head cook is responsible for, and all orders for them to do anything are given to the head cook; the steward will say, "have your man there do this, or "your vegetable cook is not giving good satisfaction, will you look into that matter." There may be a hand in the kitchen or bake house whom the steward thinks is exceptionally good, yet, some day the head cook or head baker may discharge him or her by writing on a piece of paper, "Steward, please pay off bearer—for good cause.—John Smith, *chef*. Sept. 1, 1887." And the steward will not interfere, but lets the hand go without a word—unless he is ready to dispense with the services of the *chef*. The same with the headwaiter. There is not probably a recognized headwaiter in the land, one who is known and capable, who would take charge of a dining room where the side waiters were to be hired by the steward or

any one else. He could not exact perfect obedience from his waiters without having the power to dismiss them without appeal. Nevertheless the steward can compel the discharge of a waiter who is direlict in his duty or disobedient.

#### THE STEWARD AS BUYER.

The next proposition does not admit of a straightforward answer. It is: "The steward does all the buying of supplies for the table and all kitchen utensils." Undoubtedly the coming steward will; he is wanted for that very purpose, but as a matter of present fact, as the correspondent puts it, he does not, except in a few cases. And the hotels are the worse off because of the deficiency of stewards, the buying for a hotel being a trade in itself, not to be picked up or assumed by anybody on short notice, but requiring long practice and varied experienced to become proficient in. The steward's functions in this respect are often assumed now by the proprietor. We read that one or other of the proprietors of the largest of New York hotels goes regularly to market at five in the morning and makes the purchases for the day, numbers of prominent hotel keepers, besides, have been noted as following the same practice. If it be a lack of confidence in stewards in general which has led to their being shorn of their proper authority, it is likely the stewards of past years have themselves to blame. There is very little that is pleasant in a steward's life, he has to be a sort of a policeman, austere, apparently unsympathetic, and he cannot permit familiarity, nor afford to be sociable, but most men in the position find a pleasant relaxation in marketing and driving good bargains, and when, in addition to the pleasure of smart trading, the idea of making a little private gain in a seemingly harmless way is entertained, the steward is very liable to give that part of his duties nearly his whole attention, and leave the disciplinary portion inside the house to neglect; then the proprietor volunteers to do some part of that duty

that his steward may have more time to "stay in and look after the help."

Yet no volunteer or occasional buyer can leave the office desk, or pantry, or store room and go and buy at once cheaply and intelligently. The experienced steward does not have to memorize a lot of rules to know whether game, fish, poultry or meats are fresh and wholesome or not, he knows at a glance; he has no chemist's tests about him for determining whether a sample of butter is genuine or imitation, he knows at once, he is practiced at it. The volunteer buyer, landlord or clerk rushes out and buys what he thinks are bargains because below the retail price, while the practiced steward comes in with the same thing twice as good and bought at half the price. The practiced steward does not buy small potatoes, nor small apples, nor stale eggs because they are under price, as the volunteer buyer does, for he knows they will all waste away in use and cost double in the long run, nor does he buy fruit that will not keep till next day, nor buy anything on a falling market. He knows where small supplies of a scarce article may still be found in the bye-ways of the market and keeps them in view, but does not buy till absolutely compelled, thinking that new offerings and cheaper may arrive at any hour. The volunteer buyer cannot be so systematic, nor can he watch the fluctuations of the market in staple groceries and provisions to take advantage of them as the regular steward does. The coming steward will get all these things down finer yet, including fuel and furnishing in his purchases, and he will not sell his independence and freedom to roam the markets over to any merchant for "a commission."

#### THE STEWARD PUTS IN HIS FANCY WORK.

Next, our correspondent evidently does not say what he means, his question is indirect, he says: "The pastry cook or confectioner makes all ices and creams," he probably means it is not the steward's duty to make them; right, but probably the coming steward will one day make a cream or

an ice and another day an entree or a soup, whatever else he can beat the world at, just because he can, and for the credit of his table. Even now there are hotels employing bakers, who are bread bakers only, who cannot make a biscuit, or a common custard or pudding, and pastry cooks who consider creams and ices so exclusively confectioners' work that they never try to make them, and if they are good hands otherwise, the working steward steps in and supplies the deficiencies out of his own superior knowledge. The writer knows of one summer resort, where the number of guests often reaches three hundred, where the creams, ices and fancy sweets of all sorts, except cakes and pies, are made by the proprietor's sister, with plenty of laboring help to assist, the baker having plenty else to do, and it is often said that these "little desserts" are the best things the house has to serve, which illustrates the point that the pastry cook does not always make them, although it certainly is his business.

#### ALL STEWARDS CARVE.

The next proposition: "The steward does no carving, as that is done by the cook or his assistants," is quite wrong. The only point that all sorts of stewards are agreed upon is that it is the steward's duty to carve. The ability to carve is one of the accomplishments of a gentleman. The necessity of the steward's carving is obvious, else how can he know how the meat turns out which he is buying? how can he know how much is taken and how much is left over? how can he know, whether the fault found with the meat in the front of the house is attributable to the cook's negligence or to the meat itself? how can he know what meat goes to the officers' dining room, what to the nurses and children, and what to the help? And if the head cook is to carve who is to dish up the entrees he has made which nobody knows how to dish up right but himself? and who is to watch the run that is made upon this or that dish, or the soup, or fish,

or salad, or vegetables, and provide more before the last order is gone, if his attention is engrossed at the carving table? The old steamboat stewards always carved the meat, sometimes the captain assisted. The New York City hotel stewards carve, only, when the hotel is large, there are two stewards, and the inside steward is the carver, the outside steward has no time for it. The New England stewards, who go South every winter, all carve. A steward of the writer's acquaintance, who grew up in the Niagara Falls hotels and was troubled with obesity, begged off from carving because he suffered from the heat, but he never hinted even that carving was not his proper duty. A certain California steward, who, however, has been everywhere, wherever he goes, always assumes the carving as his right, and his skill in dismembering a fowl almost instantaneously is really marvellous. A true New York City steward in a large southern hotel used to make his carving time very short and got the head cook to take hold for him, but never denied that it was his business to carve. One of our model New England stewards is now a proprietor of two resort hotels in their respective seasons, but still acts as his own steward, and his *chef* told the writer, in answer to questions on these very points, that he did his own carving until the house became so full it was scarcely possible for him to do so, and then the *chef* found him a carver and he accepted him and released himself.

#### ASSISTANT CARVERS.

The steward, being the chief carver, does not necessarily do all; in a large hotel there is a row of carvers, from three to six, or more, all at work at once, and there can be no rule about these assistants. They may be both inside and outside stewards, sometimes the second cook, for he is often set at liberty while the *chef* dishes up the entrees. Sometimes the roast cook or broiler, or the meat cutter. In some hotels one of the clerks is an expert carver and assists, in others it may be a porter who regularly



comes in. A very good combination is coffee maker and carver. The coffee man has plenty of employment at breakfast and supper making and serving the coffee, tea, chocolate and hot milk and slicing cold meats, but at dinner these things are unimportant and the coffee man finds employment at the carving table instead.

#### THE STEWARD AND THE BILL OF FARE.

Then, says our correspondent: "The steward gets up all the bills of fare."

The coming steward will, but he will be a true *maitre d' hotel*, he will be a scholar, a man of taste and grammar, he will know more than the cook, pastry cook, baker and confectioner, all combined, about dishes and the modes of preparing them and about literary composition. There are a very few such stewards now, they make the bills of fare, therefore they rule the kitchen and make, or break, the culinary reputation of the hotel. Here is a recent paragraph from the gastronomic items of an eastern paper, that reads right: "Young turkey, split and broiled, is more delicious than spring chicken. It is a dish that is very nicely cooked and served under the supervision of Mr. R. C. Amos, the experienced and judicious steward of the Revere House, whose cuisine is getting to be much talked about and tested."

That gives us the impression that it is the steward that knows what is good and the cooks are but the hands, while he is the head, that he plans and they execute, all of which is in the natural order of things and as it should be. But a person who sets up to be a steward without training and without study, and who is beholden to the cooks for his culinary information and his terms for the bill of fare, becomes little more than a tool in their hands. If he does not know more than they, he will not have their respect, and he will have no real authority. Cooks generally are not so disinterested as to work hard when they are just as free to work easy. The *chef* can make his bill of fare so that it will take the very best endeavors of all his assistants to

get the dinner ready in time, or he can make it so that there will not be enough work to fill up the hours, for he knows which dishes are tedious and difficult to prepare and which dishes are mere child's play for their easiness, and if left alone is prone to make the easy and commonplace dinners every day; he may use canned goods almost exclusively, because they are ready prepared and makes the inexperienced steward his errand boy to go out continually to buy him some more ready-made goods. If a new cook is brought into the kitchen he is likely to find a different set of utensils to work with, from those he was used to in the last place, and if he finds the steward inexperienced and weak he will get him to buy a new outfit for his especial benefit. The cook in such a case may be right, but it is necessary for the steward to know absolutely the merits and faults and the use of all the different utensils that he may be the judge of the needs in the particular department, and discern the difference between a real need and the whim of a cook. The steward who does not know this cannot take the bill-of-fare writing out of the *chef's* hands without being met with hundreds of objections to his own bill, on the grounds of there being no suitable pot for this, or pan for that, no time to make one dish and no material for another.

#### THE STEWARD WHO DOES NOT KNOW.

On the other hand the cooks would have good cause for complaint against any steward, inexperienced in culinary affairs, who should try to get up the bill of fare. There is a character in Shakespeare's *Winters Tale* very much like some of these unfinished stewards—says he: "Three pounds of sugar; five pounds of rice; rice? What will this sister of mine do with rice? But my father hath made her the mistress of the feast and she lays it on! I must have saffron to color the warden pies, (pear pies), mace, dates; nutmegs seven, a race or two of ginger, (but that I may beg); four pounds of prunes, and as many raisins of the sun."

The cooks are driven wild at times by

the immature steward's sublime unconsciousness that all these trifles which they ask for are of any sort of consequence, his vague idea that any time in the course of a month will do. "Turnips and carrots? what are turnips and carrots? common and cheap—I don't ever eat them, who cares for turnips and carrots?" But the *chef* can do next to nothing without them. "Chives, shalots, leeks, thyme, what good are they? Aniseed? What does the baker need aniseed for, and cream of tartar, and paper and hops and potatoes? I'll try to remember them sometime when I go down town."

But if the *chef* cannot get a pound of pork or bacon at the proper time, he will have no larded fillet, nor rice-birds wrapped in bacon, and without hops for yeast the baker will have no bread. It would be useless for an alleged steward of this sort to try to make bills of fare for the cooks to work up to. But the genuine steward knows what these workers want, even better than they do, things that they forget and forget purposely to avoid work.

The old palace steamboat stewards made up their own bills of fare without consulting the cooks, for they knew what they had in their ice chests when the cooks did not, and they knew what they were going to have for dinner seven days ahead, and the bills of fare they sent to the kitchens to be executed drove many a cook to strong drink. A few hotel stewards are now evidently making up their bills of fare unaided and according to their own notions, for their *menus* are original in their leading features. The ordinary practice now is for the *chef* and pastry cook each to make out his own part of the bill of fare and either steward or proprietor looks it over, perhaps rewrites it, possibly suggests changes, then sends it to the printer, but still that bill is the cook's and not the steward's. So, to come back to the original question: "Does the steward get up all bills of fare?" the answer is yes, when he is a better man than any of the cooks, and the coming steward will be that and higher priced.

#### THE STEWARD IS THE OVERSEER FIRST AND LAST.

The next proposition of our correspondent does not admit of a straight yes or no, either. It is: "It is not the steward's duty, or his assistants', to carry from the carving room and care for the meats, etc., that may be left after the dinner is over, that duty belonging to the cook."

It is the duty of the steward to see that nothing is wasted, however he may secure that end, and there is no part of a steward's duty more important to the proper conduct of a hotel than his duty to stay in the carving room or kitchen until the meal is over. Where a head cook is doing his full duty he is unable to stay there till the end; his labor is of a sort that taxes his powers of endurance, he begins his work early and finds no time for a recess until dinner is over, his own meals in the early part of the day are swallowed in a hasty manner, his mind being on other matters, and he is in no condition to stand at the carving table two hours and then stay till the last watching what may be left over. It is the cook's trade to cook and serve the meals to the waiters, the taking care of the surplus devolves upon somebody else. The actual carrying and putting away may be done by the second cook or the carver, but the steward is the director of the matter.

In a paragraph reprinted in a former article on this subject relating to a Saratoga hotel it is truly stated that there has to be an exercise of liberality in apportioning the quantities to be cooked, so that if fifty or sixty people extra should arrive there will still be plenty of dinner for them all. But if, on the contrary, the fifty or sixty do not arrive it is palpable that provisions sufficient for that many more are left over. There may be no great harm in that if the steward's watchful eye is over all to see that the house is not the loser, for such things as chickens and green peas and uncut roasts of beef are as good as new whether hot or cold for the next meal. But suppose it is the ordinary style of hotel where the crowd of waiters come to the

carving room for the remainders for their own dinner (instead of being fed before the meal begins) they will "go for" the chicken and green peas and the uncut roast of beef, and the other remainders when they are done will be remainders still. This will be the case if the steward is not present, because the carver and cooks, even the head cook, lack the power to compel the discharge of or to fine or suspend a waiter, they have the power only to quarrel and threaten, be at war with the headwaiter who defends his own men, and disgrace the house.

The way these rules actually are compromised and worked out is this: The steward who is carving and the head cook who is dishing up entrees and watching the demand upon his various dishes are both busy enough during the first hour of the meal. About that time the business slacks up, the orders come in slowly; the steward says to the cook, "We are not going to need that whole ham—I shall be able to pull through without cutting another roast—that leg of mutton will not be wanted." Then the cook himself, perhaps, or the carver who will slice the cold meats for the next meal will carry them off to the refrigerator. Later, when the steward learns from the headwaiter that the last of the always-late people are in the dining room and have been served he takes a new survey. "This whole boiled fish is good for a chowder, a fish soup, a dish of scalloped fish, a dish a la Bechamel, a fish salad, fish cakes or something else, take it away and save it. That baked fish is thin, dry, will be worthless when cold, you need not keep it." If the head cook be still in sight as most likely he will be, although not carving and no longer serving entrees, the steward calls him and asks him if he wants to save anything—and he generally does want to save the consomme—and if he has any stews or ragouts of his entrees to give away—as he generally has—and these things being all understood, the carver and vegetable cook may be left to serve out all that remains on the carving stand, and the

second pastry cook to give away the remainders of pudding and perishable sweets.

#### THE STEWARD AS A WORKER.

Next: "The steward does no manual labor, but is the head and director of all matters pertaining to kitchen and dining room."

In reality the hotel steward who does his full duty is the most hard-working man in the house, if not with his hands then with his head and feet. But our correspondent was thinking about a steward's personal dignity and his keeping a dressed-up appearance, and supposes that a steward never puts on an apron, nor has to do anything that will soil his hands. This is all wrong; the steward never does any menial duties, yet he puts on an apron very often. Even as a buyer in bad weather the active, energetic steward, clad in a rubber coat, slouch hat and heavy mud-defying boots, does not much resemble the parlor dude which country hotel boys picture the great bossing steward to be. But that fearlessness of work does not detract from his personal dignity, but rather adds to it. The source of personal dignity is not in the hands, but in the eye; wealth alone cannot buy it, a fool cannot inspire respect; some rich chuckleheads are called "Old Billy" or "Old Tommy" on all sides all their lives in spite of their unsoiled clothing. A fifty-dollar steward once objected to the writer against putting on an apron and doing some necessary thing, on the grounds that if he worked his help would not respect him any more and he could not then secure their obedience. He was not a bad man, but there was no mental or moral force in him, he had no personal dignity to spare and had to be very stingy in the use of what little he had; and this poor man came to a very humiliating end, after all, for he was knocked down by the swill-man and carried out by the police. There was another steward of a different make who also took fifty dollars because it was all the situation was worth and the house could not afford to pay more, who filled in his

time voluntarily as house carpenter, furniture repairer, locksmith, anything that might happen to want doing, in fact, bought for the house and cut the meats, and after all put on his good clothes and took a four hours watch as clerk in the office to relieve the proprietor, who was struggling to pay for his house, and the point of it is that whatever else might be forgot or neglected that working steward, when he came to do his carving, never failed to find his snowy apron laid ready, his towel hanging on its peg, his carving knife fresh ground and whetted, and his chair placed for him to rest, while waiting. He had his help in subjection, and had their respect because he was a man of force of character, no matter what he might choose to do. Another of these working stewards, another one of our New England models, though this one bears a foreign name, was formerly a steward in the Boston Brunswick, but the writer found him in a much smaller establishment where he was at once the buyer, the store-keeper or receiver, to take in, weigh and book what he had bought, the pantryman, preparing and serving the fresh fruits in good style, the issuer of stores, the writer of the bill of fare, the preparer of the meats for cooking, then the carver and finally the keeper of the keys when all doors were closed. His was not a time of kid-gloved ease and he was well aware of the fact, but then it was only of temporary duration. Two different owners of large and fine hotels, hearing where he was, went personally to see him and if possible secure his services, and he went to one of those houses, as soon as he was at liberty, where he again took his position at the head of a full force of hands. Men of this sort wield a power over their subordinates greater than the non-workers ever can, because the hands know the steward can always get along without them; he can take hold and help himself in a pinch.

#### THE STEWARD MANAGES THE MEATS.

Perhaps the remaining proposition discloses what our correspondent was really

driving at in asking the manual labor question, he says: "The steward's assistant prepares all meats for cooking, but not the steward personally."

This is one of the dividing points between the New England type of steward and the nautical New York type. The former buys the meat, cuts it up (with assistance if necessary) hands it over to the cooks, carves it after cooking, does everything except the cooking of it; the other does not cut meats, but counts that the cook's duty and has what he calls a butcher cook for that work.

The coming steward will cut meats, not all actually, but he will supervise the assistants who do, he will put the cut meats away, carry the keys of the refrigerators, and hand the meats out to be cooked. The modern, improved, systematized hotel organization is based upon the assumption that every man is honest when it is to his interest to be so, and temptations and opportunities to be otherwise are removed from the employés as far as possible. One employé is made to be a check and restraint upon another as far as practicable. The steward buys, the store-keeper receives and gives receipts, he issues and charges. If the cook sends an order for meat, receives it, cuts and trims, cooks, carves and serves it, there is no check upon him except the uncertain one of the size of his daily bill at the store-room, nobody knows what he has done with the meat. But if the steward, carrying the keys of the refrigerator himself, cuts up the loins of beef and sends them ready cut to the kitchen, when the tray is sent back for more while the meal is going on, the steward may say: "How have you used the meat I sent you? I sent you fifty porterhouse steaks, fifty tenderloin steaks along with one hundred common steaks, now you send for more choice steaks so early. What have you done with the others? Has your broiler spoiled them in cooking? Have you allowed them to be served to persons not entitled to them? Have you laid them away in reserve to sell to some private favorites?"

Have you chopped them up for your consommé instead of waiting and sending for a piece of coarser meat?" Such questions are never actually put in words, but the cook feels that the steward may ask them and the consciousness of restraint makes him watch the broiler and be more attentive to the orders as they come.

As for the dinner meats, the steward will remember that he issued fifty pounds of roast yesterday, and twenty pounds was left over, therefore he issues less to-day, and holds the carver or cook responsible for that which they took charge of after yesterday's dinner. In this way the steward holds the reins of government and hotel work goes on with the same precision as if it were a large factory. The hand labor of cutting up meat for hundreds of people in a large hotel is no small matter, for in some houses it keeps two active hands busy from morning till night. In such cases the steward only directs which meats to use first, and receives and locks up the product of the cutting. Steaks and chops have to be prepared in the greatest amounts. It is merely mechanical work, however, and easily learned. When a young man under the steward's instruction has learned to cut one loin of beef right he has learned how to cut all, if anything unusual is to be done in the way of boning or trussing the cook will do it himself. Consequently, when the hotel has not business enough to require the employment of a meat cutter exclusively, any apt hand about the house may be trained easily into doing the mechanical part of such work, the head work and managing not to lose any meat devolving upon the steward.

#### STEWARDS NEEDED EVERYWHERE.

These replies cover all the points raised by our correspondent except the statement that there are some hotels too small to employ a steward. Strictly speaking there are no such hotels. In every hotel the steward's duties are done after a fashion by somebody, it would be better if they were performed by a working steward who

would fill up his time as some do by combining these with other duties. The proper combination is steward and head cook where there is not work enough to fully employ a steward. A very common combination is steward and headwaiter being oftenest the case where girl waiters are employed, perhaps from the fact that where male waiters find such an arrangement in force the smartest one soon sets himself up as headwaiter, and the steward being late or otherwise employed allows it.

#### THE STEWARD AND THE LANDLADY.

The recipe for getting along amicably with the proprietor's wife has hitherto been kept a profound secret; it is now divulged and is alone worth the price of this book. It is this: Make yourself thoroughly master of your business before venturing where the landlady is one of the ruling spirits, after that go in confidently and be patient.

Proprietor's wives are always prejudiced in advance against the steward before he comes. They fear that their husband's importance is about to be lessened by somebody usurping his authority; the house-keeping instinct in them makes them apprehensive that their own prerogatives also are to be interfered with. They believe in advance that the steward is but a fraud and a pretender, and if they can prove him so he must either leave or lead a dog's life, and not a pet dog's either. But women generally worship efficiency. Let the new steward show skill and knowledge superior to her own, let him stand between the tricky traders and herself and husband, and buy better and cheaper, bring the help into a state of discipline, have the meals on time and served promptly, and secure for their house more praise for less outlay than before, and the recalcitrant landlady is soon subjugated and becomes of the opinion that a steward is the most indispensable adjunct to the hotel business and she couldn't keep-house without one.

#### THE STEWARD AND THE HOUSEKEEPER.

The modern hotel is so far different from the ship and steamer that the steward

does not hire or discharge the housekeeper here as he does the stewardess there. There are a few exceptions among the largest hotels, the few that are conducted as purely mercantile establishments where the proprietor's family does not reside in the hotel, and one of the two or three stewards employed—purchasing steward, inside steward or wine-room steward—has absolute control over all the employés outside of the office, but such is not and cannot be the general practice. The hotel housekeeper has a domain of her own. The housekeeper, the lady guests and proprietor's wife, who are accustomed to look to her for attentions, and the linen and laundry department are naturally affiliated together, and the steward has no business to intrude. He would need more than a sheriff's posse behind him who would go up stairs to discharge a housekeeper whom the landlady and lady guests liked, only to put another in her place more suitable to himself. In other words, the steward could never exercise his authority over the housekeeper if he were invested with it, without coming in direct conflict with the proprietress of the house.

#### THE STEWARD AND THE HEADWAITER.

"Well, thank God! that's over," exclaimed a headwaiter as he closed the dining-room doors after breakfast, "oh, but they scorched me, they burnt me up! There is no steward out there. I can't get anything out of that kitchen. My waiters go there, but never come back. The head cook does not know whether he is on his head or his feet, his men are all rattled, and the people tear me to pieces. I would not go through another such season if they would give me the house."

Thus far we have considered only the principal meal of the day, the dinner, in relation to the steward's duties, but his presence during the progress of the other meals is no less important. Perhaps there is no time when his supervision is felt by all to be so necessary as during breakfast; the urgency of this need is what impels

proprietors themselves to assume part of the out-door duties that the steward may remain in the house; this need is what first suggests the employment of an inside steward when the proprietor cannot assist. A good steward, a man of force, can get about twice as much work out of a set of waiters as they will do spontaneously if they are left alone. Although the waiters, as a class, are higher in the scale of respectability, there is such a similarity of method between the mate of a steamer and his crowd of deck hands filing past on the gang plank carrying goods on board, and the inside steward urging the waiters along during the rush of the meal, that the comparison is irresistible. The headwaiter has no business in the kitchen or carving room except to look for his waiters when they get lost, he cannot stay there to see whether they are fooling the time away, or where the fault lies. When they pass beyond the dining room doors they are out of his power and he can only wait till the powers behind the scenes send them in to him again. And some waiters will "soldier." One of them will see with a side glance some party coming in whom he does not want to wait upon and he picks up a dish from a table and darts off as if he had been sent for something, knowing that another waiter will have been detailed to attend that party before he returns, and some old dogs at the business will manage it so that they never have more than one or two orders at a time when they ought to take six or eight. The hotel might hire fifty or a hundred waiters of this sort and still never have enough. It is the business of the steward to see through and frustrate all such tricks, and also to help the waiters along by seeing that they are not kept waiting for supplies at the pantry or fruit room, or bread or toast tables, or by the hot milk being allowed to run out, or by waiting for new supplies of meat from below that ought to be brought up in time, and a hundred other trifles which require forethought, but nobody thinks of but the head man. Then there are serious knots and snarls taking place

in the kitchen. Twenty waiters are waiting for their multifarious orders at once, they grow vociferous, the more energetic thrust themselves forward and secure their orders far in advance of their turn, while the quieter waiter loses his turn over and over again, and his family of people in the dining room have the mortification of seeing people at the next table, who came in later, receive their breakfast promptly, eat it and depart before their own waiter even makes his second appearance. The simple restraint of the steward's presence at such a time is often sufficient to quell the noise and correct these irregularities, if not, he insists on the taking of regular turns, and assists the cooks to know who comes next. Under such a supervision the meals are served in the least possible time, without it the results are low quarrels and confusion worse confounded, or, at the best, when the business slackens up the kitchen and neighboring departments become a play house.

#### THE STEWARD AND HIS ADVERSARIES.

The headwaiter in some hotels is a veritable Warwick the king-maker, he can oust the steward frequently, and cause a change of *chef* every month. This is oftenest the case in what are called family hotels. It is necessary to have the headwaiter under the steward's control, to have him hired or discharged by the steward to insure thorough discipline and harmony throughout the house and for the interest of the proprietors themselves, for the obvious reason that when the headwaiter knows that the steward, in leaving his situation, will most likely unseat the headwaiter, too, and the new incoming steward will bring his own man, he is likely, from motives of self-interest, to help his steward to satisfy the people instead of pulling him down. The steward in any case has his pleasures of wielding authority fully balanced by the pains of bearing the blame for every untoward happening or deficiency in the hotel. The headwaiter, who may not be under the direct control of the

steward, can make things appear better or worse to the guests, as he chooses, and it is human nature to detract from another's good name rather than build it up, and in depreciating the character of the steward in the guests' estimation, he necessarily injures their estimation of the hotel and its proprietors.

The peculiarity of his position in this regard is this: He is always a man of respectable appearance, sometimes quite a superior man in this respect, and must be fairly well dressed. His manner is polite and his speech soft; it is his business to be attentive and appear solicitous for the comfort of the guests, and if he chooses he can become on very familiar terms with some of them, particularly with those fond of gossiping about the hotel which they are making their home, and there is no more fruitful subject for gossip than that of the table and the illiberality of those responsible for its furnishing. Encouragement from the headwaiter, such as may be conveyed by a shrug, a significant smile, a little remark that he is "sure the house pays enough to have the best" and he "can't imagine the reason that what comes in is really so unfit to set before first class people," soon leads to the current talk of the house being that the way that hotel is conducted is a disgrace to the nineteenth century civilization, and the proprietors becoming frightened discharge the steward and *chef*. Then the harmless-looking headwaiter chuckles in his sleeve and softly says: "Next!" This is not a fanciful supposition. Names and instances could be given. But suppose the headwaiter is desirous of building up instead of pulling down, how he can smooth over the temporary difficulties, softly excuse this thing being out or that expected delicacy not having arrived in time, call attention to the excellency of this dish, or the novelty of that, and promise something to come next day!

#### THE STEWARD AND THE STOREKEEPER.

Under the modern hotel system the steward does not hire or discharge the

storekeeper. The storekeeper is a clerk, he represents the proprietor in the storeroom, he is employed or dismissed from service by the same authority that engages the other clerks. If not ostensibly, he is practically a check upon the steward in the proprietor's interest, and is under the control of the proprietor direct. He receives all goods purchased for the establishment, whether provisions or crockery, or other furnishings, or fuel or ice. He demands an invoice with every purchase from the smallest to the largest. He counts, weighs or measures everything that comes in, compares his tally with the invoice or bill, notes the quality and condition of goods as they come in, marks the discrepancies, if any, then enters the actual weight or number received in his book, lying always ready for the purpose, carries out the amount according to the price per invoice to his cash column and files the invoice or bill away for future use. At the end of each day he foots up the total amount. The hotel has a stated pay day for staple merchandise, usually twice a month, and the dealers on that day send in their bills. The storekeeper takes each bill and compares it with his book, and if the amounts in each are the same he attaches his signature and "O. K.," and the dealer then takes it to the cashier in the front office who pays it and files away the receipt. If the amount of the bill presented is not the same as that carried out in the storekeeper's book he turns to the invoice or former bill on file and finds what he wrote upon it when the goods were received, as so many pounds short weight, so many tubs of butter below the grade invoiced, fifty per cent. of eggs worthless, so many pieces spoiled, so many pieces broken, etc., and explains that much to the dealer. The storekeeper only records the facts and allows payment for what he actually receives. Any difficulties that arise in consequence are between the dealer and the steward, who must settle them. When the dealer is satisfied his bill as corrected is allowed and he takes it to the cashier to be paid. When transient

marketing is bought by the steward, the amounts are weighed by the storekeeper, who makes a bill of each lot, signs it, and the farmer or huckster takes it to the cashier's desk and receives payment at once.

#### THE STEWARD AND HIS STOREROOM.

The steward is proud of his well-stocked storeroom and spends whatever leisure time he may have in it. In one sort of storeroom, now found in modern-built hotels, the steward spends most of his time while on duty, for from it he can oversee all that is going on. The storekeeper is to all intents and purposes the steward's own clerk, even his private secretary, who saves him a vast amount of care and book-keeping. Their relations are precisely that of employer and employé and they are on the most friendly terms, the trifling fact of the storekeeper being an appointee of the front office and in a measure independent of the steward is perhaps seldom thought of by either.

There are two different patterns of storeroom in use and two different methods of issuing stores, just as there are two different classes of steward. The New England style of storeroom is in the kitchen itself, either built so that a part of it like a shop front opens into the kitchen while the back opens upon the street where the goods are taken in, or the room originally built as a kitchen is partitioned off that part may serve as a storeroom, and here the storekeeper remains all day, serving out goods to the different departments as they are applied for, starch and soap to the laundry, toothpicks, matches and stationary to the office, fruit, cheese, milk and bottled goods to the pantry, lemons and sugar to the bar, and all the various articles except meats needed by the cooks and bakers. He enters all the items in his book and charges them to the various departments, and the rest of his time is taken up in receiving stores, auditing accounts and taking account of stock needed to be ordered and once a month or oftener of the amount of stock on hand. In this storeroom the steward



remains during breakfast and lunch or supper, and such times as he is not carving, for here he can hear every order that is given and all that goes on in the kitchen, being ready to step out if any difficulty arises or any special rush of business, and while there he writes his letters to merchants and supply men, looks over his accounts, posts up his books, notes down the orders for supplies suggested by the storekeeper, and keeps count of the changes among the help, filling out a blank for each and handing it in to the cashier. One of our model stewards passes the most of his time that way, there being no local marketing to do in his locality, and nearly all orders for goods having to be sent by mail or telegraph. He has a little box of an office in the corner of the storeroom that is less than four feet from the kitchen table, and all that is ordered at the storeroom counter he hears, and sees, if he cares to, where it goes. This may not be perfectly admirable. Perhaps neither the reader of this nor the writer would like to work under such close surveillance, yet it shows to what a point systematic hotel-keeping has been brought. In this instance, fortunately, the ever present steward is an amiable man, and if he sees his workers in their easy moments he also is with them when the crowd is in and he knows how well they earn their money. The defect in this style of storeroom is in its requiring the storekeeper to be always present, and the hotel has to be of a large size to afford one hand for that one duty. The intention under that system is that the cooks shall never have in possession more material than they need immediately, and it is easy for them, for the storekeeper becomes in effect a waiter to hand trifling amounts to them continually. On the other hand the cook can complain that he has no check upon the storekeeper when the order system is dispensed with, for he may draw fifty pounds and the storekeeper hating him may enter in his book seventy-five pounds, and so injure the cook by the apparent extravagance of his bills. By the other

system the cook sends a written order to the storeroom for material and keeps a duplicate of the order himself, so that in case of an accusation of extravagance, which may lose him his situation and his character, he can appeal to his duplicate orders to see whether he has been misrepresented. The method of ordering and issuing supplies from the other style of storeroom, distant from the kitchen, is fully detailed in another place. The defect of that system consists in the propensity of the cooks to order too much at once; having a day's supply on hand and such apparent plenty, they use the material more lavishly than if it is counted to them pound by pound. A competent steward knows how to remedy the defects in either case, and there is not much preference to be given to one style over the other. It will be understood that the written order system *can be* operated as well in the open storeroom adjoining the kitchen, but, as it is so much easier and quicker to do without an order, it rarely or never is.

#### THE STEWARD AND THE CARE OF MEATS.

Take care of the meat, all the rest will take care of itself. It seems most shocking to people in general to waste bread because such has been the teaching of their childhood, but where abundance of other things besides bread is in hand, as in our hotels, the expense of meat makes that of most other items seem insignificant by comparison.

In order to realize how like the wasting away of meat is to that of a block of ice in the sun it has to be considered that only prime cuts of the carcass are selected in the first place. These, under the latest improved system, are subjected to a preserving process, being dipped in a solution of which the composition is at present a secret, and, whether so treated or not, are dried, chilled and sometimes even frozen in a cold-blast refrigerator, then wrapped in several coverings of paper, packed in hogsheads and shipped by rail or steamer to all parts of the country, usually reaching the

destination, which may be a thousand miles away, still in a semi-frozen condition. Still, this meat, when it reaches the hotel meat-cutter's block, is only raw material. There is the bone to be taken out, that is from one-fourth to one-third of its weight gone; there is the outside to be pared off; there is the inevitable loss of weight in cooking; there is the risk of loss through the negligence of cooks; then the cooking of too great a quantity and having it left over with the chances doubled that what is so left over will not be useful any more, and will be entirely lost. That is all under the most favorable circumstances.

But the times that try a steward's efficiency are the unfavorable times when the meat arrives in bad condition, when the weather suddenly turns warm while the hotel meat house is full of meat, or the number of people to be fed suddenly diminishes before the stock on hand can be worked off; and other unfavorable times are those in a resort hotel where the weather is most trying and the supplies are irregular, there being at one time two or three carcasses, and barrels of poultry to be taken care of at once, and then nothing fresh for several days. The thorough steward is, however, equal to the task of meeting all these difficulties and makes of them no difficulties at all, when the untrained and inexperienced man stands helpless, blames the weather and has the whole hotel, the kitchen, carving room and dining room for days in succession full of the sickening odor of tainted meat.

Here is an instance of the employment of steward's common sense which may prove serviceable. A hotel man finding himself out of employment at the end of a summer season, bought the dining car privilege on a train carrying a very large excursion party out to an interesting part of the country on the newly built railroad. It was the last week in September, oysters in season, but still dear. The man loaded up with oysters, raw, soldered tight in cans, which came by express packed in ice. There was every prospect that the oysters

would prove the favorite dish with the excursionists and he would soon sell out his stock, and such might have been the case had the weather remained cool, but it changed to summer heat again and oysters were not in demand, and, next, the train ran into a lot of game, which interested the passengers and kept them feasting until their return home. The hotel man's cases of oysters remained on hand, still in ice, but highly perishable stock. A man less accustomed to the care of provisions might have sold a few of them to the restaurants at a greatly reduced price and have lost the rest, but our steward packed the cans in an ice chest in a layer of broken ice and salt, more ice and salt on top, more cans on that and more of the freezing mixture on top of them, and the oysters were half frozen in the cans and could have been kept for weeks, but as the spell of warm weather had prevented the dealers from ordering any for a few days, the steward's frozen stock was all there was in town and he retailed them out at a good profit. Another example: A new steward went to a city hotel in the trying time of midsummer and found that tainted meat served at table was the rule rather than the exception, and the waste of meat which became totally unfit for use with amazing rapidity was enormous. He took the meat out of the refrigerator, where they were keeping it, altogether. He had a long discarded ice chest cleaned out and a draining rack of cross pieces laid in the bottom. He placed his loins and wasts of beef and quarters of mutton on that. He bought sheets of light canvas and laid one clean washed on top of the meat, and on the canvas he spread plenty of ice. On the ice again he placed his smaller meats, lambs, poultry, tongues, sweatbreads, covering them with a sheet of canvas, and that again with ice and closed it down. Every second day he unloaded the ice chest, placed the newly killed meats at the bottom, to remain there and season and become tender, and the old stock on top to be used next, and refilled the box with ice and occasionally had the canvas

sheets washed and bleached. This going back to the old fashioned ice chest looked like retrogression, for the upright refrigerator, where meat may hang up and keep dry in a cold atmosphere, is the later improvement, but the requirements of different places are different and *it all depends upon how the refrigerator is used*, whether it is the best preserver of meat or not. In this case there was no more loss from spoiled meat; there was scarcely another pound thrown away that summer. Meat kept in ice is wet and in danger of becoming soaked and divested of some of its juices and fine flavor, but when the other alternative is a hot weather taint and the greenness of incipient decomposition, the ice box method is infinitely preferable.

One more instance of very recent occurrence may prove instructive: A large new hotel was finished up and furnished with great liberality, as regarded the expense, the desire on the part of the owners being to have everything right, the cost of it being only a secondary consideration. The refrigerator meat house was therefore built of large capacity. The upper part would hold a car load of ice at once, the lower or meat room was a good sized butcher's shop, large enough both for storage of a good lot of meat, and for barrels and boxes besides, and still had room left for men to work in. Yet, when the trying time of blazing hot days and sultry nights came the refrigerator utterly failed of its purpose and the meats spoiled in it with frightful rapidity, the choicest and costliest imported roasts and loins having to be thrown away by the hundreds of pounds at a time. This was largely owing to the incapacity of the cook, but the immediate cause was the too frequent opening of the refrigerator both at top and bottom, the general arrangements being insufficient for the needs of the house, and the one large receptacle being made a place of half-hourly traffic. Hot air was admitted every time the door was opened and the ice sometimes was diminished to a small quantity, hence the meat spoiled quicker than if it had

never been chilled at all. The remedy applied in this case was the removal of everything but the fresh' meats and, there being no other ice house, the providing of a pile of blocks of ice buried in sawdust outside, to be drawn from for every other purpose, and the refrigerator was then kept strictly closed spite of all excuses and reasons to the contrary, and then it proved effective for its purpose.

The steward who has meats to manage that are not select and not shipped in to him ready trimmed avoids loss by attending to the selection at once as soon as it arrives. He has the shanks, flanks, necks and breasts cut off and consigned while fresh and untainted to the soup boiler, to the salt beef barrel, to stews and meat pies, holding back live poultry and things that will keep till these perishable goods are used up, and packs away the choice cuts in refrigerators or ice boxes in which there is plenty of room and of ice through the roughness having been first disposed of.

The other possible sources of loss of meat, which the steward has to watch, are the great stock boiler, the cook's roaring fire, the gaping swill barrel and the surreptitious back door basket. Of these the stock boiler is the most ravenous and consumes the house's substance with the most harmless and innocent expression of countenance and the most plausible excuses and the promise to give it all back, which it seldom does. The roaring fire may be satisfied to take tainted or dirty meat, the swill barrel will be content with cold cooked joints, but the hungry stock boiler will consume a hundred pounds of the freshest meat and relieve the cook of all trouble of working it up, and then return nothing but a *consommé* which nobody cares for, and which will be rejected even in the officers' dining room where it is that or none.

#### THE STEWARD AND HIS MANAGEMENT OF HELP.

A new steward cannot get along with old help. Such is the rule. The old hands.

all think they know more than he possibly can know, they do not want to do new ways, they feel disposed to tell him, he being a stranger, how they do and how he ought to do, instead of looking to him for direction. When the old hands are good and worth keeping the proper way to do is to call them up, one at a time, offer to pay them off and turn them over to the new steward, for him to hire them over again if he wants them and if they want to remain. It may be productive of temporary inconvenience to have any of them leave, but it is far better in the long run, for it is a formal investment of the new officer with his proper authority, without which he can not run the back part of the house according to his best ability. When a head cook leaves his second expects to leave, too, or be discharged; only a few exceptional men in that position ever remain without the formality, at least, of being paid off and beginning anew under the new head cook. So in the case of a new steward; the head cook and headwaiter expect that their situations will be wanted for new men of the steward's own, and if they are expected to remain it is best to go through the same formality with them and let them all begin anew. In most cases where a new steward comes in it is to be inferred that either there was no steward employed there before, or else there has been laxity of administration or corruption or misdoing which has led to the change being made. Then it is most desirable all around that "a clean sweep" should be made. Let the really good hands come back after a time and be hired over again. This rule is good and even necessary, as has been observed already in the case of the headwaiter, for if each hand's place depends upon the duration in office of the steward, each one will be more likely to uphold him and his rules than to oppose him.

As a measure of defense when he is but one against so many, the steward keeps other hands in view continually. Perhaps he finds it convenient to keep in communication with an employment agency, more

especially for the finding of the commoner sort of help, who are always changing their situations.

He does not seek to be popular with his help. It is not good business policy for the steward, or head cook either, to let the help praise them too much. The head cook is a little less bound, he may let his men have a half day off by turns, considering that they have no Sunday, but the steward can not afford to make any such concessions of his own accord. The least familiarity leads the help to ask favors in food or holidays, or drawing pay out of pay times, and if the steward yields in any case his power is broken.

He decides according to the kind and style of hotel whether the waiters shall have their meals in their special dining room before the guests' meal time arrives, or whether they shall eat after the meals are over, he also fixes the time for meals for all the other hands, then posts up the rules and the notice with them that they will lose their meals if they do not come within half an hour of the time specified. The steward, after consulting the cook, fills out a printed blank bill of fare each day for the officers' dining room, which takes in at its several tables the clerks, housekeeper, linen keeper, engineers, carpenter, barkeepers and various others. If there are two soups, this bill of fare has one allotted to it, fish, perhaps, and one or two kinds of meat, and in all about half the variety which goes to the guests, and all expensive extras are omitted. A similar selected bill of fare is allotted to the nurses and children's ordinary. As regards the discharge of the hands under the head cook and headwaiter, the steward who sees they are idle, inefficient, or not longer needed requests the head cook or headwaiter respectively to dismiss them, and it is expected that they will at once comply with the request since it is but a matter of courtesy to them. But for all flagrant offences such as drunkenness, using profane and obscene language, gambling within the house, insulting females, insolence to

guests and patrons of the house and the like, the steward instantly discharges any hand without ceremony. Fines are imposed in some cases for minor delinquencies and under some circumstances the direlict hands are suspended from employment and thrown upon their own expenses temporarily.

It is the steward's duty to ask of every strange face that appears in his departments why it is there, to watch that no idlers are admitted and to be sure that every hand hired is at once entered in his book; name, for what purpose employed, wages, date. A copy of this memorandum he transfers to a printed blank and hands it in to the cashier. When a hand is to be paid off, he fills out another printed blank, with date, name, time due—that is, not days, but such a part of a month at so much per month—occupation, or what class of service the money is paid for, signs it as steward and sends the hand with it to the cashier's desk to be paid.

#### THE STEWARD AND THE HANDS' PAY DAY.

All rules are off where there is no regular pay day. The hotel that is in debt to the help is in a bad way; they break away from the restraints of discipline, work but to suit themselves and always have it in mind to say: "If I don't suit you pay me off!" and in such a house the steward has no business.

The good hotel rule is to have a set day each month when the wages due is handed to each and every employé of the house in a sealed envelope, superscribed with the individual's name and the amount of the contents. Most hotels pay on the tenth of the month, paying up to the first and holding back ten days' pay until the hand leaves finally and then the ten days' reserve is paid. Some proprietors choose the fifth for pay day, keeping back only five days' pay; a few choose the fifteenth, keeping back half a month. Some of the largest hotels, however, have two pay days each month, as the third and seventeenth, or fifth and twentieth. For several reasons the tenth

of the month is the best day, and the ten days' pay always retained till the hand leaves is sufficient restraint. Were the employés paid up in full they would frequently leave the hotel without a word of notice. If paid on the fifth they frequently sacrifice the five days pay due them in order to get away without giving notice, or finding a substitute to take their place. When finally paid off by the steward the ten days' reserved pay very frequently is all they have saved to live upon until they find new employment, and its retention until such a time is a real benefit to them.

On the morning of the pay day, or on the day before in a large hotel, the steward looks over his time book, notes time lost by absence, by sickness, fines, money drawn (which can only be drawn through another blank filled out by the steward), and any other remark; sets down the amount due against each name, with particulars, and hands the list to the cashier, who compares and corrects his own books accordingly, and at a convenient time the help are ordered to go to the cashier's window all at once and are paid, the steward standing by to identify each one if necessary. In the smaller hotels, however, the steward or a clerk goes around and hands the envelopes to the owners without their having to leave their work.

#### THE STEWARD AND THE CLERKS.

The steward, having to count the cost of meals, cannot make up his estimates, nor complete his accounts, without a daily house count from the office made up as is fully detailed in this book in another place. He therefore applies to the clerks for such house count, not as a favor, but as his right and their duty. Usually the night clerk makes the count before breakfast, if he fails the steward applies to the chief clerk to have the remissness corrected. It is the duty of the chief clerk or the proprietor, as the case may be, to notify the steward of the expected arrival of any unusual number of people to be entertained that he may provide accordingly, and in like manner to

warn him of the departures that he may reduce his kitchen estimates in proportion.

#### THE STEWARD AND THE PROPRIETOR.

"And what shall *I* be doing all this time!" some proprietor will ask, who has read thus far. Well, there was once a very handsome and popular hotel proprietor, whom the writer knew, sitting on the piazza among his guests and one of them asked him about something in the back of the house and why he had it so. "Well, sir," said the proprietor, "I have a steward, an excellent man, and very capable to attend to all those matters, and I think I build up my business better and make more money by remaining in front and looking after the comfort and pleasures of my guests, than I could by hiding myself away in the interior and leaving you all to the small share of attention you would get from the over-worked clerks. Whatever is worth doing is worth doing well. I give my steward entire charge of the inside of the house and do not interfere with him, and I take entire charge of the front myself." There was nothing very striking in this reply, but it outlines the chief duty of the proprietor to himself as he understood it. Very few men are adapted by nature to be at once a genial host in the front and an austere disciplinarian inside the house. At present, it is true, a great number of proprietors are performing the more responsible part of the steward's duties, because they have no steward, and the head cook is trying to do the rest. The effect will be when every hotel has its real steward in his proper place that there will be fewer managers, assistant managers, clerks and men of mixed duties, there will be more cooks and fewer *chefs*.

The relation of the hotel steward to the landlord is the same now as the land steward of scriptural days was to the land owner; he gives an account of his stewardship.

Under the modern hotel system the steward comes to the proprietor's private office with his books or transcripts of them in hand and shows what it is costing per

meal and per day to run the house in its present style. His accounts, properly kept, show at a glance:

- How many people were in the house to-day.
- How many meals where served.
- How much value of material the meat cook used.
- How much the pastry cook used.
- How much the pantry man or woman used.
- How much the head laundress used.
- How much the office force used.
- How much the barkeeper used.
- How much these amounts are above or below the average.
- How much per meal it cost for all hands.
- How much it cost for the guests.
- Cash value of stock in store room this night.

#### THE INSIDE STEWARD'S SPECIAL DUTIES.

Where there is too much work for one steward two are employed. The purchasing steward not having time to remain in the kitchen and carving room during the two or three hours of each meal the inside steward steps in. The duties are not different from what has been already detailed, but they are divided between two and the inside is the second, if one must rank the other, the purchasing steward having charge of the accounts and the cost per meal and per day of running the house, while the inside steward has immediate control of the kitchen and dining room. The special need of an inside steward is most apparent when a hotel has a number of private dinners, suppers and banquets to get up as a part of the regular business. Then the inside steward is the one to be consulted upon the subject of the *menu* for each occasion. He is required to be acquainted with all dishes, wines and the etiquette of the table. He decides the choice of viands, knowing which are in season and which are most suitable for the time, due regard being had to the amount of money the purchaser wishes to spend. The inside steward is more than a headwaiter and supersedes him in many cases, for the inside steward enters the dining room and

has the private dinners served under his own supervision and management.

#### THE WINE-ROOM STEWARD'S SPECIAL DUTIES.

Wine stewards are employed in hotels where a large bar and banquet business is done. It is the duty of this steward to have his store-room open, very much like the kitchen store-room, during meal times and be ready to hand out the bottled wines, liquors, ales, mineral waters, etc., to the waiters, according to the orders written on the cards and signed by the headwaiter, which they bring to him. He buys wines, etc., for the house by the barrel and bottles them; perhaps rectifies, mixes, compounds, bottles and labels various spirits and cordials. He issues supplies to the bar and books the amounts the same as the storekeeper issues material to the kitchen, and he issues to the store-room supplies of liquors to be used in cooking, and wines and beer allowed to the cooks for their meals, where such is the rule, and charges the same to kitchen store-room like any outside merchant. He also has charge of the cigars and tobacco for the bar. He mixes and sends up from his cellars ready for use the champagne cups, claret cups, punches and the like required for the private parties taking place in the house, and sends the bill of the amount at once to the cashier to be charged in the guests' bills.

#### THE STEWARD AND THE DAIRY.

The steward having in charge the furnishing of the table is responsible for the quality of the milk and for the furnishing of cream for the coffee, oatmeal and berries, etc., holding somebody else responsible to him. It is good for the hotel, its table and reputation when it has a regular dairy department in connection with the proper conveniences and a dairy woman to attend to it. Where such is not the pleasant state of affairs the steward establishes rules of management of the daily supply of milk furnished to the hotel to such effect that the cream from it will be secured for the coffee, making the purchase of cream so much the lighter expense, and allowing

only the skimmed milk to be used for culinary purposes. Generally some hand can be found among those already employed who has a special aptitude for taking care of the milk. Sometimes it is the pantry girl, sometimes the coffee maker or the storekeeper.

#### THE STEWARD AND THE DISH-ROOM.

The steward is directly responsible (holding somebody else responsible to himself) for the appearance of the crockery and glassware as it goes to table. The dishes, cups and saucers and all the rest must be bright and spotless, not showing marks of being smeared over with a wet and much used towel, but shining with the polish left by clear and very hot water, the glassware the same. The cream pitchers and water pitchers need special watching that the inside be well cleansed. The steward also watches the dishes as they pass him coming from the kitchen to see that there are no thumb marks and splatterings of gravy on the edges.

He has to see that the dishes after washing are covered up and effectively secured from flies and dust.

He is responsible also for the dishes being kept warm, in a dish-heater or otherwise, and makes rules against the waiters and others destroying dishes by placing them to get hot upon the range.

Accordingly he has shelves, closets, draining racks, warm closets, dry towels, mosquito net coverings, and all such appliances made in the manner best adapted to the particular circumstances of his house.

The dishwashers, pantry woman, scrubbers, ice man and yard man are directly under the steward's control, to hire and discharge them without reference to any heads of departments whatever. The better the hands he can secure in these menial situations the lighter will be his cares.

#### THE STEWARD AND HIS WORKSHOPS.

The basement story of some large hotels resembles a small factory where each tradesman is doing his part towards the comple-

tion of some immense work, and a great number of trades it takes to keep up and supply the needs of a large hotel. In one of these rooms is a soap maker and assistants, and the necessary tanks, boilers, presses and drying room, all furnished with steam heat. The soap maker not only makes the common sorts for the laundry and for the floor scrubbers to use, but makes fancy toilet soap for the guests' rooms, the name of the hotel stamped on each cake. In another room the hotel confectioner superintends the making of the jellies and preserves for the house, there being one or two assistants employed in these operations, and at other times in the same room the pickles, catsups, chow-chow and sweet pickles are made, and there is an occasional canning and bottling of fruits and vegetables from the hotel farm, when the ripening season is on. Further on the furniture repairer is at work with cabinet makers' tools and glue, and a turning lathe and scroll saw are in motion close by; then there is the blacksmith's shop adjoining the engine room, then the great engine that, perhaps, operates the elevator, keeps the laundry machinery in motion and whirls the ice-cream freezers, and another engine for the electric light. The meat-cutting room is very likely to be found in this basement story, and the oven where the loaf bread is baked, the pastry oven having to be upstairs and near the dining room as the kitchen is, for convenience of service. All of these are under the control of the purchasing steward except the engineers, and he must purchase fuel also for them. The fruit and sugar for the confectioner, the materials for the cabinet maker and for the soap maker, and whatever other trades may be there are all, in these largest establishments, purchased by the steward, and the hands are accountable to him for their time and quality of workmanship, the same as in the eating and drinking departments above.

Thus it is seen the steward, whether he be the man-of-all-work in the smallest hotels, or whether multiplied into three or

four of one name in the largest, is the real operative hotel keeper. And yet some hotels have no steward!

#### WHEN THE STEWARD'S GOOD TIME COMES.

Compare the actual duties of the thorough hotel steward, as they have been detailed, with the ideas of those who think they will, as stewards only have to go to market, buy something and make their own little "per cent.," walk around the house a time or two and then sit down in a shady corner and doze the happy hours away, and the discrepancy between fact and fancy will be found so great as almost to take away the hope that truly efficient stewards ever can be made out of such poor material as usually offers. Nor does there seem to be much encouragement for more capable men to undertake duties so arduous, unless they will look further into it and behold the perfected hotel and its system of working departments running with the smoothness and certainty of a great factory, wheel within wheel, and he himself the directing head of all. A man cannot be steward of a hotel and give it a divided attention—it takes up all his thoughts. He cannot be steward and take an interest in politics, nor write a book, nor a play, nor carry on a business of his own down town. Stewarding is of all things a thoughtful occupation. Every individual that meets the steward in the hotel wants something—something to be purchased, to be remembered, to be tried for and not secured, and tried for in another quarter. Every individual the steward meets has to be an object of his mental inquiry, has to be thought over in regard to duties and conduct. Every hour of the day has its special claim upon the thoughts of the steward, from market hours to meal hours, train times, mail times and appointments. Every individual in the house blames the steward for something, either openly or covertly, from the scullions, who complain that the steward's soap will not cleanse anything, that his matches will not light and his stove wood is wet and will not make a fire,



through all the departments of fault-finders to the dyspeptic guest in the distant room, who blames him for the butter or syrup or meat or bread not being to her liking, or for the failure to find a special something in market that was not there to find.

Yet, spite of all this, a man who can govern himself and therefore can govern others, may have a moderately easy time as steward of a good hotel. He may be like that one of our model stewards mentioned, as sitting in his office in the corner of the store-room within four feet of the kitchen table. He has telephone connections in his office and speaking tubes to the different departments. His storekeeper is an able second to him and needs no watching. His head cook is thoroughly efficient and reliable, can govern his kitchen and needs no watching, his pastry cook the same. The headwaiter is one of the best, is on the most friendly terms with the steward and cooks, and his well-trained waiters are assiduous in their efforts to please the guests and are free from all the faults which some waiters need watching for. The house is prosperous, the business is steady, each one employed does his or her part; there is no noise, no quarelling, no friction anywhere.

This is the easy condition reached through the firm enforcement of rules and the steady weeding out of poor help and replacement with better, and the encouragement of well-doing by trifling promotions and judiciously bestowed words of praise. Then the steward takes his hour or two of recreation in the evening without the fear of a strike among the waiters, or of a desertion of cooks, or unmade fires and late meals to wear him out in the morning, and his thoughts run out to the pleasanter prospect of securing the first strawberries of the season or a new variety of fish for his next *menu*, and occasionally he finds time to bestow a pitying thought upon any man, who has not yet found out that the hotel he stewards for and his table are the best in the world.

#### WHO SHALL BE STEWARDS?

Every hotel being in want of a real steward, and only a small number being at present supplied with such, it is evident that, when the stewards do come to their own again, they will crowd out somebody that is now standing in their shoes. They will crowd out the "assistant manager." There is no such a thing as an assistant manager, the man so called is occupying the steward's place without doing the steward's hardest work. They will crowd down the present crop of *chefs* and make head cooks of them. There is no such word as *chef* in the English language, nor in American-English. When a head cook becomes such an object of respect that he must be named in italic print and made conspicuous in that way all over a newspaper page, it shows that he is more than head cook, he is a grade above, and that grade in English is steward; in French also, it is steward, the French *chef* is equivalent to American steward. The French cook is *le cuisinier*. The French *chef-de-cuisine* is the *chief of kitchen*, he is more than *cuisinier*, he is the managing, meat-cutting, carving, bill-of-fare writing, wine serving, kitchen-governing man, known to the American hotel system as steward. The French *chef* of to-day is the same as the *maitre d' hotel* of a century ago. *Maitre d' hotel* is literally master of the house; every French nobleman's house used to be called hotel, his steward was his *maitre d' hotel*. We are accustomed to reading in English of Ude, Vatel, Marin, Bechamel, and others being cook to such a king or prince, but the French reading is not cook, but *maitre d' hotel*, steward—something higher than *cuisinier*—the same thing, in fact, as our working and governing stewards, who can invent dishes and show others how, if need be. The old term *maitre d' hotel* seems to have dropped out of use, the French now have only *chefs*—chiefs of the kitchen, with all that it implies. Jules Gouffé was called, and called himself, *chef* to the Paris jockey club, but

he was far more than a *cuisinier*—he was wine steward and an authority on wines; he was an authority on confectionery, canning and preserving, and on meat cooking as well. That is the sort of man he understood a *chef* to be—the same as a most accomplished working steward is with us. Are the head cooks of the generality of hotels that sort of men? If not, why call them *chefs* in italic conspicuousness? If there are some such why not apply the English word and call them stewards? *Chef* is generally thought to mean cook. Steward is a title of higher rank, and those who deserve it ought to wear it.

#### PROMOTE THE GOOD COOKS.

There is no school wherein a young man can learn thoroughly the masterful duties of the hotel steward but the live hotel itself. There are three departments in which the business may be learned. From waiter to headwaiter and then steward may do very well. From storekeeper to steward is better. From head cook to steward is best, and is in the natural course of promotion.

A superior class of young men have come into the hotel cooks' ranks of late years. They are no longer the corner loafers and drunken castaways, the ignorant, profane and obscene outcasts, who secure the good places in the hotels. Many of the cooks, who write to hotel papers, now write good business hands and can indite a good letter, they give evidence of having received a good common school education in most cases, in some instances they exhibit much more than that. These are adapted to become stewards. They have been attracted to the hotel cook's occupation by the liberal scale of wages offered for efficient men in that line, and they find, on trial, that the hotel cook is not a servant, but a master mechanic who has a chance of next becoming a superintendent or steward. Some among these are total abstainers from strong drink, or else have control over themselves to resist excess. They are readers, and quick to detect ridiculous blunders in a bill of fare. Some of them cherish that principle of free citizenship

which makes them scorn to sell their vote for a bribe, and the same principle will prevent their selling their independence to any trader for a bribe. They know the best article in market when they see it, and they want it wherever it can be found, and they wear nobody's collar and buy nobody's stale merchandise. These are the coming stewards. There is no other training so good to make stewards as the cook's training. A man who can govern the kitchen can govern all the rest of the interior, and the man who as head cook has had experience of all kinds of provisions and has practiced writing the bill of fare, is a steward almost already. Such men should be promoted to the position of the sort of steward that has been described in the foregoing pages; not promoted to the lower rate of compensation which stewards now generally are receiving, but promoted to still higher salaries than the *chefs* are getting, with all the honor, authority and responsibility of stewardship superadded.

#### HOW STORES ARE ISSUED AND CHARGED.

The proprietor of a hotel of small or medium capacity generally has no patience with the "red tape" methods of making requisitions, booking and checking and counter-checking, which he may hear are practiced in metropolitan establishments; he says: "if I didn't think my man was honest I would not have him in my house; if he is determined to steal from me he will steal anyhow, and blank forms to fill out would have no effect; my way is to hire none but those whose honesty I have confidence in, and then I trust them implicitly and let them know that I trust them." Those are the pleasant sort of men to deal with, and theirs are the houses where employer and employes are like one family. The strict rules are not for them. But take the big city hotel where some 200 hands are employed and some among them leave every week and strange faces take their places, and the united family feature disappears and, instead, a system as hard and unsentimental prevails as any

that governs a company of miners or mill operatives. No sympathy exists between the lowest grade of workers in the various hotel departments and employers, who each appear to be seeking to take advantage of the other whenever an opportunity occurs.

In such houses all the doors are guarded. One bears the notice "No admittance to see the help under any circumstances." Another says, "You are not allowed to remain in the store-room." Another, "You will be discharged if you come in here without permission." There the coffee-maker must count the number of cups he serves out and on no account give out a cup to any employé without express permission, the fruit room and pantry goods are all guarded with the same strictness and a watch is kept upon the hands employed in them, the same as upon the coffee-maker.

Even where a more cordial feeling exists the great number of employés makes a personal acquaintance impracticable, much less individual trust, and a strict and formal accounting in every department is adopted as a measure of the sternest necessity.

The genial hotel keeper who objects most strongly to those "red tape" measures and is slowest to buy the necessary blanks and books, after once becoming accustomed very seldom abandons them. As to how much of them should be adopted in any given size of house, must of course depend upon the disposition of the proprietor and the degree of personal attention he gives the business. The two different styles of hotel store room have been already described. Apart from the question of which is the better, many of the largest and best conducted houses have no room for a store room in connection with the kitchen, it must be in the basement because the plan of building did not allow for it upstairs. In such places the chief cook, the pastry cook, the headwaiter, the housekeeper, the chief clerk and, perhaps, the barkeeper and other heads of departments write a requisition for the day's or half-day's supplies in a printed blank like this:

tion for the day's or half-day's supplies in a printed blank like this:

HOTEL BELVIDERE, Nov. 24, 188-

Storekeeper deliver to bearer:

Beef Loin,-----18	lbs.		
" Roast-----18	"		
" Butts-----21	"		
Mutton-----6	"		
Veal-----16	"		
Pork-----18	"		
Fish-----10	"		
Butter, table----3½	"		
" kitchen-----2	"		
Coffee-----3½	"		
Tea-----4	oz.		
Syrup-----1	quart.		
Milk-----4	galls.		
Lard-----2	lbs.		
Oatmeal-----1½	"		
Grits-----4	"		
Sugar cut loaf---4	"		
" powder-----4	"		
" help's-----2½	"		
Mackerel-----10	"		
Eggs-----6	doz.		

JOHN SMITH, Chef.

The blank book from which this is torn has a duplicate form, which the chief cook, or other requisitioner, fills out with the prices and total, as follows, and keeps it:

HOTEL BELVIDERE, Nov. 24, 188-

Storekeeper delivered to bearer:

Beef Loin-----18	lbs. @ 19c.	3	42
" Roast-----18	" 8c.	1	24
" Butts-----21	" 9c.	1	89
Mutton-----6	" 9c.		54
Veal-----16	" 6½c.	1	04
Pork-----18	" 6½c.	1	17
Fish-----10	" 8c.		80
Butter, table--3½	" 30c.	1	05
" kitchen-----2	" 20c.		40
Coffee-----3½	" 30c.	1	05
Tea-----4	oz. @ 60c.		15
Syrup-----1	qt. @ 60c.		15
Milk-----4	gal @ 30c.	1	20
Lard-----2	lbs. @ 11c.		22
Oatmeal-----1½	" 4c.		6
Grits-----4	" 3c.		12
Sugar cut loaf-4	" 9c.		36
" powder-----4	" 9c.		36
" help's-----2½	" 6c.		15
Mackerel-----10	" 3c.		30
Eggs-----6	doz @ 20c.	1	20
		\$16	87

JOHN SMITH, Chef.

It may be asked: "What does the chief cook want with the duplicate, when the goods have been entered in the storekeeper's books before he receives them?" The answer is, it is a part of the unsentimental system of making one employé act as a restraint and a check upon another. The waiters on watch cannot close up and leave the dining-room until the missing knife or spoon has been found or charged up to some delinquent; the chambermaid cannot get a clean towel from the linen-room until she brings the dirty one to be exchanged for it. It has been shown how the steward becomes a check upon the cook and the storekeeper upon the steward, and now the cook, and indeed each other one who makes requisitions, becomes a check upon the storekeeper.

The supposition acted upon is that the bar-keeper might send for five pounds of sugar and the storekeeper might enter it in his book ten pounds; or the cook might draw twenty pounds of meat and the storekeeper might enter it thirty and might then throw five pounds of sugar and ten pounds of meat out of the window, without coming out short at the monthly stock-taking. Without looking as far as that, the cook keeps the duplicate accounts for self-protection, because the steward will come to him at night and say, "Your bill to-day was twenty dollars more than yesterday; the proprietor will expect an explanation, do you know what made the difference?" and the cook will want to know whether he has been subjected to an overcharge in the store-room and will look over his own account for that and the preceding day to see how it was, for it is to be observed that an unaccountable increase in the store-room bills fastens upon the cook the accusation of extravagance which he does not wish to incur. The pastry cook, baker, confectioner, pantryman and every other one who draws supplies is in the same position as regards their daily accounts, though none have such large amounts to answer for as the chief cook.

#### THE STOREKEEPER MUST RISE EARLY.

One of the most serious of the minor difficulties is connected with the issuing of supplies early in the morning. If the bakers and cooks get a late start, not only will the breakfast be ill-cooked and short of some of the dishes which the bill of fare promises, but they scarcely will catch up with their work during the whole day. The bakers want material to use at four o'clock in the morning, the subordinate cooks need numerous things such as oatmeal, lard, potatoes, cracker-dust, onions and potatoes to get their respective shares of the work of preparation done before the head cook comes. The requisitions for the several departments have been written out the night before, and when the storekeeper throws open the doors, there is a rush of work upon him, and while he is weighing, measuring and booking the supplies issued, a valuable half-hour or more is lost, perhaps, by each of a dozen hands, and if he is late himself the trouble is so much the more serious. It is contrary to good hotel rules and to good policy to issue the stores overnight, the store-room is the place provided to keep such property locked up in. But to facilitate the morning issues the good rule is to have the requisitions from kitchen and bakery sent down over night, together with the pans and pails to hold the goods, the storekeeper fills the orders and books the amounts before closing up, and when the doors are opened next morning the stores can be handed out without delay.

#### STORE-ROOM HOURS.

In every well regulated hotel there are four times in the day, periods of one hour each, when stores are issued, after that the store-room doors are locked, and it must be something very urgent to make them open again before the next regular time. This rule is necessary to prevent the storekeeper's time being consumed by a constant doling out of trifles, it makes the cooks and others *think* what they are going to want and make one order of it. For the

storekeeper has much else to do besides issue provisions as has been already shown, and must close his doors in order to do his book-keeping, receiving, auditing accounts and stock-taking. The times of issue are early in the morning and then just after each meal, or, rather, while each meal is in progress he issues for the next meal, because it is absolutely necessary that he shall be in the store-room during meals, to be ready to issue special goods which may be unexpectedly needed for some particular orders.

#### THE STORE-ROOM ISSUE BOOK.

The following pages show three different ways of keeping the issue book. The first is for a written book, an ordinary blank journal will answer, and the storekeeper will draw a line or two on each page as he uses it. The requisitions which come from the different departments repeat themselves every day in the great majority of items, only varying in the amounts called for, thus, the cook always call for the staple meats, fish, poultry, butter, lard, potatoes, etc., and the pastry cook or baker always repeats flour, meal, sugar, butter, lard, eggs and the other staple needs. Therefore the storekeeper when he uses a written book, takes advantage of leisure opportunities and goes several pages ahead and writes in their proper lines the names of such daily staples as is seen in the first specimen page, but leaves vacant lines to write in such articles as are only called for occasionally, then when the issues are made he only has to write the number of pounds of the staples instead of the whole line. The specimen pages here following show the rest. It will be observed that a comparison of the totals of the bills run up by any department, can be had instantly by turning over the pages of the account book.

The storekeeper of the medium size hotel

from whose written pages the two following are copied, has not added the prices of articles as he went along, as the frequent repetition of the same items, and his thorough acquaintance with everything through his other duty of booking the purchases and examining bills and prices made such itemization unnecessary. He knew that the cost of kitchen butter was fourteen cents per pound, and set down the five-and-a-half pounds at seventy-eight cents, avoiding superfluous writing. The four separate entries of butter in the same line show that a requisition for that commodity was sent from the kitchen each time that the store-room was opened.

As various forms are used in different hotels the specimens on pages 36 and 37 are subjoined for the purpose, principally, of showing how numerous the articles are which are required to stock the storeroom of a large hotel. These pages are copies, reduced in size, of the ready-printed requisition lists of one of the largest hotels, a house capable of accommodating one thousand guests at once. It is not, however, a pattern to copy after as regards its interior organization. These printed lists are intended to serve the double purpose of saving the time of the chief cook and the baker, by giving them the least possible writing to do and to take away the excuse of forgetfulness and frequent sending to the storeroom by enumerating almost every possible thing that can be wanted.

When these requisitions have been filled and the stores issued, the items and amounts are copied from them into a book as in the other case, at the storekeeper's first opportunity. Any party who may be concerned in the opening of a new hotel may find it profitable to go over these lists attentively before deciding that their storeroom is completely stocked and ready.

Friday, December 11, 1888.

KITCHEN.

Loins .....		00	Bro't forward.....	\$22	69
Roast, 16 .....	I	28	Chocolate .....		00
Butts, 15—14.....	2	71	Chickens, 20—16.....	3	20
Lamb, 8—10.....	I	26	Apples .....		20
Veal .....		00	Wine, ½ .....		15
Pork, 12.....		78	C. Fish, 4 lb.....		24
" Salt .....		00	Oysters .....		45
Liver, 4 .....		30	Potash, 4.....		28
Sausage, 8.....		64	Salt, Brine, 15 .....		10
Hams, 14.....	I	54	Kraut, 3.....		24
Tongues, 1 .....		20	Turnips, ½ .....		25
Bacon, 5.....		50	L. Peas, 5 .....		35
Fish, 10—12 .....	I	54	Barley, 1½ .....		12
Mackerel, 8.....		24	Turkeys, 4.....	I	84
Onions, 1 .....		20	Macaroni, ½.....		10
Cabbage, 10 .....		18	F. Peas.....		20
Parsley, 1 .....		10	Oil, 1 .....		13
Irish Potatoes, ½—1 .....	I	13	C. Berries, 1 .....		50
Sweet " I .....		40	Mushrooms, 1 .....		25
Corn .....		00	Candle, Hall, 1.....		02
Tomatoes, 1—1 .....		60		\$31	31
Grits, 4.....		06			
Oat Meal, 1½ .....		06			
Corn " .....		00			
Coffee, 3½—2½ .....	I	20			
Tea, 2—4 .....		18			
Rice, 4 .....		28			
W. Sugar, 1—2—I .....		25			
Brown Sugar.....		00			
Butter, 1—1½—2—I .....		78			
Lard, 2.....		15			
Milk, 1 .....		23			
Eggs, 10—5—10.....	5	75			
Soap, 1—I.....		10			
Soda, 1 .....		05			
		\$22			
		69			

Friday, December 11, 1888.

BAKERY.

D. ROOM.

C. Meal, 8.....		12
Milk, 4.....		90
Eggs, 6—3.....	2	07
Butter, 4.....		60
Lard, 3.....		21
W. Sugar, 6.....		42
Pow'd " 6.....		50
Brown " 4.....		26
C.Loaf ".....		00
Brandy, ½.....		15
Molasses, ½.....		10
Apples, 5.....		25
Pumpkin, 1.....		38
Currants, 3.....		24
Salt, 12.....		08
	\$6	28

Nuts, 3.....		45
Raisins, 3.....		45
Oranges, 5—3.....		96
Apples.....		20
W. Sugar.....		00
C. L. " 4—4—4.....		90
B. " 2¼—2¼.....		29
P. ".....		00
S. Milk, 4¾—4—5.....	3	08½
B. ".....		12½
Butter, 3½—3½—3½.....	2	62
Syrup, 1—1.....		30
Cheese, 1¾.....		20
Preserves, 3.....		33
Crackers, 2.....		12
Bananas, 100.....	1	00
	\$11	03

LAUNDRY.

Brooms, 1.....		25
C. Paper, 6.....		54
		79

OFFICE.

Scrubbing Brush.....		15
Blacking, 1.....		10
Oil.....		15
Brooms, 1—1.....		50
C. Paper, 6.....		54
Soap.....		20
	\$1	64

RECAPITULATION.

Kitchen.....	\$31	31
Bakery.....	6	28
D. Room.....	11	03
Laundry.....		79
Office.....	1	64
Ice.....	1	40
TOTAL ISSUES.....	\$52	45

## CHIEF COOK'S REQUISITION.

Store Room Keeper will deliver the articles enumerated below by quantity,-----188

ARTICLES.		ARTICLES.		ARTICLES.	
....	Lbs. Pan Fish.	....	Pk. Cranberries.	....	Lbs. Black Pepper.
....	" Boiled Fish.	....	Can. Green Peas.	....	" Red "
....	" Broiled Fish.	....	Pk. " "	....	Oz. Mustard.
....	Cans Oysters.	....	Can. String Beans.	....	Bot. Olive Oil.
....	Qts. " "	....	Pk. " "	....	Qts. Taragon Vinegar.
....	Cans Clams.	....	Can. Lima "	....	" Apple "
....	Lbs. Roasting Beef.	....	Qt. " "	....	" White Wine "
....	" " Mutton.	....	Bun. Asparagus.	....	Pts. Wine—Catawba.
....	No. Breast of "	....	Can. " "	....	" " Rhine.
....	" Shoulder of Mutton.	....	Doz. Green Corn.	....	" " Port.
....	" Rack " "	....	Can. " "	....	" " Claret.
....	" Loin " Veal.	....	Pk. Tomatoes.	....	" " Sauterne.
....	" Rack " "	....	Can. " "	....	" Cordial—Anisette.
....	" Shoulder " "	....	Pk. Cucumbers.	....	" " Maraschino.
....	" Breast " "	....	Bun. Radishes.	....	" " Curacao.
....	" Loin " Pork.	....	Can. French Peas.	....	" " Chartreuse.
....	" Rack " "	....	" " Beans.	....	" American Champagne.
....	Lbs. Spare Ribs, "	....	" Succotash.	....	" Brandy.
....	" Corned Beef.	....	" Macedoine.	....	" Rum.
....	Cans " "	....	" Okra and Tomatoes.	....	Lbs. Raisins.
....	No. Turkeys.	....	Qts. Split Peas.	....	" Currants.
....	" Chicken Broilers.	....	" Navy Beans.	....	" Citron.
....	" " Roasters.	....	Pk. Apples.	....	Oz. Lemon Extract.
....	" Ducks.	....	" Pears.	....	" Almond.
....	" Geese.	....	Can. Salmon.	....	" Vanilla.
....	Lbs. Liver.	....	" Crabs.	....	Lbs. Flour.
....	No. Kidneys.	....	" Lobsters.	....	" Corn Meal.
....	" Ox Tails.	....	" Shrimps.	....	" Cracker Meal.
....	Lbs. Tripe.	....	" Green Turtle.	....	" Oat Meal.
....	No. Calf's Head.	....	" Mock "	....	" Manioca.
....	" Sweetbreads.	....	" Sardines.	....	" Cracked Wheat.
....	" Calf's Brains.	....	" Condensed Milk.	....	" Cornstarch.
....	Lbs. Sausage.	....	" Desiccated Cocoanut.	....	" Gelatine.
....	No. Beef Tongue Pickled.	....	" Peaches.	....	" Rice.
....	" " " Smoked.	....	" Pears.	....	" Tapioca.
....	" " " Fresh.	....	" Apricots.	....	" Sago.
....	" Hams.	....	" Figs.	....	" Farina.
....	Pcs. Breakfast Bacon.	....	" Cherries.	....	" Grits.
....	" Smoked Beef.	....	" Pineapple.	....	" Barley.
....	Doz. Salt Mackerel.	....	Doz. Lemons.	....	" Italian Paste.
....	Lbs. Salt Codfish.	....	" Oranges.	....	" Macaroni.
....	Cans Codfish Balls.	....	" Bananas.	....	" Vermicelli.
....	Doz. Scotch Herring.	....	Jar. Anchovy Paste.	....	" Spaghetti.
....	" Holland "	....	Can. Mushrooms.	....	Oz. Mace.
....	Pks. Irish Potatoes.	....	" Russian Caviar.	....	" Allspice.
....	" Sweet "	....	Bot. Truffles.	....	" Cinnamon.
....	" Turnips,	....	" Gumbo File.	....	" Cloves.
....	" Parsnips.	....	" Curry Powder.	....	" Nutmegs.
....	" Beets.	....	" Mushroom Catsup.	....	" Ginger.
....	" Peppers, Green.	....	" Walnut "	....	" Whole Pepper.
....	" " Red.	....	" Capers.	....	" Sage.
....	" Carrots.	....	Pt. Olives.	....	" Thyme.
....	" Squash.	....	" Worcestershire Sauce.	....	" Sweet Majoram.
....	Doz. Egg Plant.	....	Bot. Chow Chow.	....	" Celery Seed.
....	" Cauliflower.	....	" Mixed Pickles.	....	" Bay Leaves.
....	Pks. Salsify.	....	" Gherkins.	....	" Chives.
....	Hds. Cabbage.	....	Lbs. Currant Jelly.	....	" Chevril.
....	Doz. Lettuce.	....	" Apple "	....	" Burnet.
....	Pk. Spinach.	....	" Cheese.	....	Lbs. Yeast Powder.
....	" Turnip Greens.	....	Doz. Eggs.	....	" Bi. Carb. of Soda.
....	" Kale.	....	Qts. Milk, Fresh.	....	No. Ball Potash.
....	Bun. Parsley.	....	Lbs. Butter.	....	" Matches.
....	" Mint.	....	" Lard.	....	" Twine.
....	" Celery.	....	" Brown Sugar.	....	" Paper.
....	" Leeks.	....	" A "	....	" Soap.
....	" Garlic.	....	" Pulverized Sugar.	....	" Candles.
....	" Cress.	....	Pk. Salt.	....	" Pencil Tablets.

-----Chief Cook.

Chief Cook is earnestly requested not to order in excess of actual wants, and to return all articles not used at the end of each meal to Store Room Keeper. He will also see that none of his subordinates make use of profane or obscene language while on duty.



OCEAN HOUSE BAKERY.  
BAKER'S AND PASTRY COOK'S REQUISITION.

Flour .....	Lbs.	Peaches, Pie .....	Cans.
Rye Flour .....	"	Peaches, Table .....	"
Graham Flour .....	"	Apples .....	"
Buckwheat Flour .....	"	White Cherries .....	"
Corn Meal .....	"	Red Cherries .....	"
Butter .....	"	Gooseberries .....	"
Lard .....	"	Raspberries .....	"
A Sugar .....	"	Blueberries .....	"
Pulverized Sugar .....	"	Blackberries .....	"
Syrup .....	"	Muscatel Grapes .....	"
Brown Sugar .....	"	Catawba Grapes .....	"
Corn Starch .....	"	Pie Plant .....	"
Soda .....	"	Green Gages .....	"
Yeast Powder .....	"	Irish Potatoes .....	Pks.
Hops .....	"	Sweet Potatoes .....	"
Malt .....	"	Salt .....	"
Des. Cocoanut .....	"	Vanilla Flavor .....	Qts.
Chocolate .....	"	Lemon Flavor .....	"
Raisins .....	"	Almond Flavor .....	"
Currants, Layers .....	"	Raspberry Flavor .....	"
Currants, Seedless .....	"	Pineapple Flavor .....	"
Citron .....	"	Strawberry Flavor .....	"
Figs .....	"	Rose Flavor .....	"
Gelatine .....	"	Molasses .....	"
Apple Jelly .....	"	Sweet Wine .....	"
Quince Jelly .....	"	Dry Wine .....	"
Peach Jelly .....	"	Brandy .....	"
Raspberry Jelly .....	"	Rum .....	"
Mince Meat .....	"	Condensed Milk .....	Cans
Allspice .....	"	Sweet Milk .....	Gal.
Cloves .....	"	Sweet Cream .....	"
Mace .....	"	Lemons .....	Doz.
Cinnamon, Ground .....	"	Bananas .....	"
Ginger .....	"	Oranges .....	"
Fennel Seed .....	"	Farina .....	Lb.
Shelled Almonds .....	"	Sago .....	"
Apricots .....	Cans.	Tapioca .....	"
Pineapple .....	"	Eggs .....	Doz.

Date, .....

.....  
*Baker and Pastry Cook.*

Pages 38 and 39 show, greatly reduced in size, leaves from the most elaborate form of storeroom account book. Blank books of this pattern with the headings, rulings and everything printed except, of course, the figures and unusual items, are copyright property. The system is, however, only the same as that on pages 34 and 35 carried up to the highest class of hotel with its more numerous departments, and the book large enough to admit the totals

from the receiving books and meal count and steward's daily memoranda. It will be seen that the day's transactions are shown by this book at a glance, and the amount of stock in the storeroom is known at any time. There is a monthly stock taking, however, to verify these totals. Taken in connection with the previous explanations of the workings of the steward's department this example explains itself, and may be studied with profit

HOTEL BELVIDERE.

Date, Friday, July 23, 1887.

KITCHEN.				FRUIT PANTRY			
21 lbs.	Mutton -----	2	63	1 qt.	Vinegar -----		10
38 "	Loin -----	7	60	2 cans	Milk -----		32
1 Bbl	Potatoes -----	3	50	8 qts.	Figs -----		56
3 lbs.	Rice -----		15	-----	Fruit -----	2	80
1/2 "	Coffee -----		12	-----	-----	-----	-----
2 bars	Soap -----		16	-----	-----	-----	-----
3 Dz.	G. Corn -----	1	00	-----	-----	-----	-----
2 "	Parsley -----		90	-----	-----	-----	-----
1 pk.	S. Beans -----		75	-----	-----	3	78
1 "	Beets -----	1	20	-----	-----	-----	-----
12 qts.	Milk -----		96	HELP'S HALL.			
20	Chickens -----	4	85	-----	-----	-----	-----
1 lb.	Tea -----		43	5 lbs.	"A" Sugar -----		35
1 "	Crackers -----		06	2 "	Gran. Sugar -----		15
1 Can	Tomatoes -----		19	3 cans	Milk -----		48
7 lbs.	Gran. Sugar -----		47	2 lbs.	Butter -----		34
1 pkg	Pearline -----		10	-----	-----	-----	-----
2 cans	S. Beans -----		11	-----	-----	1	32
2 "	Peaches -----		40	PASTRY ROOM.			
7 lbs.	Lima Beans -----		27	2 lbs.	Raisins -----		30
8 "	Pea Beans -----		25	2 "	Currants -----		12
2 cans	Corn -----		20	1 "	Citron -----		08
-----	Ham and Butter -----	3	81	1 "	Gran. Sugar -----		07
-----	Butter -----	5	19	6 "	Pul. " -----		42
-----	-----	-----	-----	6 cans	Milk -----		96
-----	-----	-----	-----	1 bot.	Vanilla -----	1	70
-----	-----	-----	-----	1 pkg	Yeast -----		09
-----	-----	-----	-----	-----	-----	3	74
-----	-----	-----	-----	ENGINE ROOM.			
-----	-----	-----	-----	-----	-----	-----	-----
-----	-----	-----	-----	-----	-----	-----	-----
-----	-----	-----	-----	-----	-----	-----	-----
-----	-----	-----	-----	LAUNDRY.			
-----	-----	-----	-----	1 pkg	Pearline -----		10
-----	-----	-----	-----	2 doz	C. Pins -----		08
-----	-----	35	24	-----	-----		18





STORE ROOM ACCOUNTS.

BROUGHT FORWARD									
BARBER SHOP.				47	76	WINE ROOM.			
-----		-----	-----	-----	-----	Stock on hand, morning Issues -----			
TURKISH BATH						Sales -----			
-----		-----	-----	-----	-----	Stock on hand, night -----			
Total Issues		-----	-----	47	76				
Total Receipts forward		2318	56						
Receipts to-day		-----	-----	185	20				
Total		-----	-----	-----	-----	2503	76		
Total Issues forward		1581	96						
Issues to-day		-----	-----	47	76				
Total		-----	-----	-----	-----	1629	72		
Stock on hand, morning		736	60						
Add		-----	-----	137	44				
Stock on hand, evening		-----	-----	-----	-----	874	04		
						Morning Count		-----	-----
						Average Cost			37
						Actual Meal Count			127
						Actual Average Cost			34.8

A blank book of unusually large size is required for the elaborate method of keeping the store room accounts shown on preceding pages, in fact it is intended for both storekeeper and steward or manager to make entries; the former carries out his own part showing the amount of the daily issues etc., and the steward using ink of another color (to show which were his own entries, in case of dispute) fills in the number of meals served and the cost per head. As in such a case the storekeeper is almost sure to use a common memorandum book to

make his entries in first, at the time of issue, and copy it into the big book afterwards the objection of "double trouble" will be made everywhere but in the largest hotels and another method is here offered, sufficiently simple for use in a written book yet more comprehensive than the first example. The "recapitulation"—which is for the proprietor to see at a glance—is here unnecessary, the totals appearing in a separate column plain to see, and these columns added separately, prove each other and reduce the chances of making mistakes.

## CHANGING COOKS IN A LARGE HOTEL.

This is the most serio-comical occurrence that ever takes place in grand establishments. Some hotels make changes so often that all concerned get used to it, they get the mode of procedure down to a fine point; still the operation is always a critical one, attended with serious dangers, which can only be safely laughed at after the crisis is past. For everything in a hotel, even the very continuance of the business, depends upon the cooks, the lapse of even a single meal would shake up the house and bring consternation upon the people equal to a small earthquake; it is the difficulty of making the connections so close that the one intervening meal will not be dropped that makes the experience exciting. The determination to make a change is not often reached suddenly, but the complaints and dissatisfactions grow and increase through several weeks, perhaps months. There is no particular reason why a chief cook, who does not give satisfaction, should be retained except the fear of undertaking the delicate task of making a change of administration. There are always plenty of fine cooks ready to take employment in the hotels which will pay high enough salaries. So the complaints go on and grow for a while. There are bickerings and fencings, defiance and sharp words betwixt the chief cook and those in authority over him so constantly that a state of sullen enmity becomes the ordinary rule of their relations. All at once a change of temper takes place. The steward or manager or proprietor, as the case may be, begins to act very pleasantly toward the chef, they treat him to smiles—sarcastic smiles, but perhaps he does not detect the sarcasm. He has his own way undisputed and grows good-natured, too. It is wonderful then what peace and harmony pervades all the culinary departments; it seems impossible for anybody to do wrong, for no more faults are found and there is no more driving. The fact is the steward and proprietor have been telegraphing and writing and

have secured their new man, and try to practice such extreme secrecy about their movements, lest the chef should suspect the truth too soon, they nearly overdo it, and it is only the latter's egotism that prevents him from seeing that something is going to happen, for all those around him are conscious that things are not what they seem, and while they whisper about among themselves, not really knowing anything, they have nothing openly to say. Next, there are two or three strangers seen taking back seats in the office or waiting room; they came on the morning train. Strangers of all sorts are arriving constantly, that is nothing, but, somehow, these do not seem to be of the usual sorts. One of them, at least, is well dressed, but they do not act like commercial travelers nor like men of leisure, the very hall boys observe that, and when it is seen that the steward is more concerned with them than the clerks are, a light begins to break and the whisperings about the house increase. Then the steward takes the strangers, or at least the best dressed one of them, and shows him inside the dining room, then the breakfast room and ladies' ordinary, then to the pantry, if that happens not to be in plain sight of the kitchen, then takes him back to the office, where they have a long talk. By that time the headwaiter knows all about it, although not a word has been said to him, for he knows that if it had been any other stranger viewing the house out of curiosity, it would have been the proprietor or a clerk showing him around instead of the steward. But why so much secrecy? Because the chef above all things hates to have it said that he was discharged, or that he was "rolled," *i. e.*, pushed out of his place by another chef. He may not care for the loss of the situation, may even be glad of a rest, but he wants the first word and to say that he quit; and if he knows for certain that a new chef has come to the house, he will pull off his jacket instantly and make his second and third cooks do the same, will gather up his knives and all will go to the office and demand to be paid off. The

steward wants the first word, too, but he thinks more about the ensuing meals and desires to let the new chef in at night when his opportunities for getting acquainted with his new surroundings will be better than between meals. Therefore he continues the secrecy to the latest moment, waits until all the cooks have left the kitchen in the afternoon, then shows the new chef the interior and takes him to see the ice chest, and as soon as supper or evening dinner is well ready, he informs the present head of the kitchen that his money is ready for him in the office and he will not be required to prepare breakfast. Some men at such a juncture are kinder and better natured than others and yield gracefully, that is, they act like gentlemen and throw no obstacles in the way of their successor. Common men, however, immediately go around and undo whatever they can that has been done in preparation for the next day. They throw out their soup stock, their salad dressings, their espagnole and other sauces, their aspics, their croquette preparations, their codfish balls, which were ready for breakfast; they stop the vegetable parers from their work, forbid the replenishment of coal and kindling boxes, in short do whatever they can think of in half an hour to make it hard for the fellow that comes after them. The pastry cook under the same circumstances throws away his yeast and neglects to set the sponge for the morning bread, hides away the baking powder, puts soda in the cream of tartar package, hoping to cause mistakes, puts salt into his wine jellies and custard mixtures, hoping the new man will use them, breaks the oven damper and stuffs rags into the flue. And yet the breakfast appears on the table the next morning the same as usual, and if any difference is observed by the guests, it is very likely to be in the way of improvement, for the new hands are anxious and doubly attentive.

The obstacles thrown in the way of the new chef do not set him back because the tricks are all so old, he knows them all

himself. He takes no notice of what his predecessor has done, or what he has left behind him, but begins everything anew, even if he has to bribe some of the help to work late that night; and, if the former chef has left a can of his favorite sauce or a salad, just to give the new man something to pattern after, the new man puts on a scornful smile and pitches it into the swill-barrel. The new pastry cook knows in advance all about the yeast trick, and has brought some fresh yeast in his pocket ready for the fray; he tastes and tests everything, walks straight to the chimney and pulls out the stuffing of rags, throws out the former pastry cook's treacherous compounds, which he knows are only snares to entrap him, and then goes to work, and the day succeeding sees everything going on as usual; the crisis is past.

#### HOW THE NEW CHEF BEGINS HIS DUTIES.

Sometimes the change of cooks is made by common consent when the one wants to get away for reasons of his own, and there is then no secrecy and no surprise, which must be regarded fortunate for the new man, for no matter how well experienced he may be, he finds the first day in a new situation a hard one, even when everything is left running on in its proper order, and so much the worse when the late incumbent has done all he can to make it hot for him. It is hard at first to find any article that he wants, he must find the thing by searching in various places instead of being able to lay his hand upon it from habit without thinking, and then his kitchen hands are strange to him. However, he has his own second cook, perhaps one or two more whom he knows. Beginning at night, he first makes sure of his fireman, finding out if he can be relied upon to have the fires made early enough, and he sees to it with his own eyes that the fuel is good and easily reached. He divides the breakfast work in his own mind into three divisions, the meats, the fries and the vegetables. The meats include everything that is to be broiled, also the eggs, and he sees whether

the small meats are ready cut and in the refrigerator, if the whole list which appears upon the breakfast bill of fare is there, or whether only part is ready; then he proceeds to cut or have cut and prepared the missing articles, which may be chickens, fish to broil, or ham. The fries include fish, oysters in all ways, fried potatoes, chip potatoes, fried mush, codfish balls, breaded cutlets, liver and tripe. The vegetables are not really vegetables, but are miscellaneous dishes grouped together that way, because prepared in part by the vegetable cook; they are oatmeal, cornmeal mush, grits, stewed potatoes, hash, fried onions, stewed tripe. Some of these things the vegetable cook carries out complete, others, such as the stews, that cook only prepares by cutting up ready and the second cook finishes. The meat division belongs to the second cook, though he probably will have the meat cutter, or some other, to do the broiling, he having to dish up orders and do the most of the egg cooking; his first part of getting ready for breakfast is the making of the stews and assisting with the frying of cutlets and breaded fish, the third cook being busy getting enough Saratoga chips and French fried potatoes along with other fries to keep ahead of the orders. The head cook's duty is to "make" his eggs, as the kitchen phrase is, that is to cook them as ordered, but this he only does during a rush of orders, and after seeing that everything is running on right and nothing has been forgotten, he leaves the front of the range and puts in every minute he possibly can in preparing his soups and entrees for lunch and dinner. His ability to run the kitchen is according to his ability to remember everything that must be done and every item of material that will be required to work with; he makes out his requisition over-night, and it will be well for him, if he does not forget something of small value seemingly, yet quite indispensable, and it is no less important for him to know which one of his half dozen assistants will do each particular thing, and to give them their orders accord-

ingly. After the first newness is over, each of these hands will know the part he or she has to perform, and will do the same every day, but at first all the strain is upon the head cook.

The first breakfast is, however, only half his cares; at the same time of survey of the breakfast meats over night, he also sees what there will be for dinner, plans the bill of fare, if the steward has not planned it for him, and looks about for the wherewithal to make his first dinner in the house a credit to himself, and then he must see that whatever will require the most time is begun first, and must plan the work of each one of his helpers. His second leaves the breakfast work next morning like himself, and begins the work on lunch and dinner, and side by side they both do the same work, boning veal or fowls, stuffing, larding, barding, cutting meat small, cooking, pressing, cooling and re-cooking sweet-breads, mincing mushrooms, onions, parsley, cutting truffles in dice, boning, pressing and afterwards cutting up the cooked calfs head for soup, making croquettes, filleting fish, cutting croutons of bread, preparing salads, making sauce, finishing the soups; and the second cook as his special duty makes the sweet entrees, while the third or roast cook roasts and boils the plain meats, the vegetable cook prepares all the vegetables, except such things as breaded and fried egg-plant, and another cooks meat for the hands.

When the sixty or eighty different operations have been merged into the thirty or forty dishes, which constitute the meat cook's part of the great hotel dinner and the meal is about ready, he takes a bill of fare which has just come from the printers, calls the half dozen principal helpers to him and reads off each item, every accompaniment, every sauce, every form of vegetables, and asks if that is ready. If anything has been forgot, they make haste to get it ready yet before the doors open.

When the dinner is about over, and the quantities have proved to be just right, and no person has been denied anything he



called for, the headwaiter steps into the carving room and passes some pleasant remark to the steward; the steward strolls over to where the new chef stands, makes some pleasant remark to him and they shake hands. Soon after the chef finds most of his assistants near him, and suddenly he says:

"Well, boys, how was that for a dinner?"

"Went off first rate," says one cautiously.

"A pretty good dinner," says another, with slowness and great emphasis on each syllable.

"Well I should say it was!" exclaims the chef, with more emphasis still, "considering it was the first day, too! Boys, there's a bottle of beer a-peice for you in the basket under my desk—there's a bottle or two of Rhine wine there, besides, if any of you would rather have it, help yourselves." And the chef goes to his room.

#### THE DRINKING HABITS OF COOKS.

While there are and can be only a very few hotels of the largest size and highest style, what few there are have great influence in setting the fashions in interior management, and many among the vast number of smaller hotel proprietors, as well as their employés, have had unpleasant experiences of the slighting manner, the real contempt with which the cooks from those larger hotels speak of the smaller and less pretentious houses, because of their denial of certain privileges and their greater regard to expenses. But one of the customs of the largest hotels, is a decidedly pernicious one and brings back punishment upon the employer by increasing the habit

of intemperance among their employés, that is the custom of serving out regular rations of liquor and an almost unrestricted issue of wines and liquors on demand, ostensibly for cooking purposes. It looks generous in the hotel-keeper, but it is not really so, but the cooks secure the concession through their united demands. When a cook is wanted, telegraphed for, written for, as shown in a preceding page, he first inquires about the amount of salary offered and next stipulates how much liquors and wines per day shall be allowed to the kitchen. When he gets to work, first thing among the morning issues from the storeroom comes a quart of whiskey, which he divides among the hands, taking two shares for himself. At the cooks' nine o'clock breakfast, instead of coffee they each drink a pint of cheap California wine, or, if they do not like that, they are allowed a pint bottle of beer, and at least once or twice more during the day wine or beer is served out again, while the chef, as well as head pastry cook, has a supply of various liquors always at hand. They would be more than human, if they could avoid excess under such circumstances. But cooks must drink something, theirs is a thirsty occupation. They do not need the whiskey early in the morning, and that is the most harmful of all their allowances, but let the hotel keeper or steward act as their friend, give them the needed bottle of weak wine or cool and harmless beer in the heat of the day when the work is hard, and never allow bottles of rum or other liquors to be issued at all. He should pour the wine in the soup and brandy or rum in the sauce himself.

# HOW TO WRITE THE BILL OF FARE.

With a great many persons occupied daily in the preparation of the hotel dinners, the composition of the bill of fare is the one literary effort of their life, it is their first timid step upon the threshold of the temple of *belles lettres*, where they begin to use the strange words of a strange language and watch for the effect to see whether they are understood and whether they have said them aright. The words and the language and the whole operation of forming the bill of fare, are strange for the reason that our people generally are not "gastronomically educated," as the latest phrase has it; neither the great mass of the people, who come to the hotels, nor many of those whose business it is to cater to their wants, have ever studied the subject of the composition of various dishes and their proper names, or thought much about the correct order of serving them, while still it is felt that a code of gastronomic proprieties must have been formulated somewhere in the upper regions of culture, and every sort of writer of the bill of fare tries to show his acquaintance with it according to his light. In looking over a promiscuous collection, especially of hotel dinner bills, it is not difficult to pick out the bad examples which show how "fools rush in where angels fear to tread," and also the specimens which have emanated from a student of the subject who feels a proper pride in his performance, because he understands the motives which lie at the bottom; the great majority are, however, of the sort that are written as a task which must be performed daily by somebody and bear no marks of the pleasure which that task possibly may bring, when the reasons for every line and every sort of arrangement are thoroughly comprehended.

## THE AMERICAN HOTEL DINNER BILL THE STANDARD.

Premising, for the information of the learner, that there are other forms of the bill of fare suitable for private parties, formal banquets and for club dinners, it may confidently be asserted that the present general form of bill in use at the hotels of the United States and Canada is the best for the purpose of the regular dinner or *table d' hote* system, and the most perfect which could be devised, both for the display of culinary proficiency and for the allowance of the freest choice to the dinner. This statement is made for the benefit of those who may chance to pick up specimens of old-country bills divided into "First Service—Second Service," or "*Premiere Service—Deuxieme Service—Troisieme Service*," and the several different forms adopted by various clubs for the sake of singularity, as well as the specimens of dinners served in courses, all of them forms not suited to the requirements of the hotel dinner and therefore not to be adopted unawares in the effort for improvement.

The present form has, so to speak, formed itself in accordance with the tastes and requirements of the people for whom hotels exist, the arrangement of dishes is according to their home-formed habits; by which is meant that our people take meats and savories but once in the meal and do not take meats again in the "second service," but only sweets and fruit.

## THE HOTEL PRESS AND RECENT IMPROVEMENTS.

The good taste and good sense which characterizes the hotel bill of fare in general is largely attributable to the course of teaching and criticism of the hotel newspapers for, up to a few years ago, a vast proportion

of the bills were very ridiculous affairs and the greatest mostrosities among them were those which they that wrote them thought were the best. It is only about a dozen years since hotel papers came into existence. Before that time there were no sources of information on such subjects but a few antiquated cook-books which taught by-gone styles, and the mixed bills of the cooks of various nationalities employed in the larger hotels. These showed lists of dishes enough and good ones, of course, but without the translations of their names into plain English and the statement of the reason for their appearing in any particular order of succession, such examples did more harm than good. The subsequent intelligent discussion of the questions led to such favorable results that there is no difficulty now in the learner finding a reliable pattern since the bill of almost any good hotel may be taken as a model, while the main arguments on the various points may be found in the hotel books now in existence and need not be gone over again in this place. Some minor questions still arise, however, which will be briefly stated in order to a full understanding, it being noted in advance that a perfect uniformity in the bills of all the hotels would be very undesirable; we can usually select our favorite newspapers from a pile of papers through some individuality of appearance, their type, their make up, their color, their headings or absence of them, and we should value this stamp of individuality just as much in hotel bills of fare as in newspapers.

#### BILL OF FARE OR MENU.

Strictly speaking these words are not of quite the same significance. The menu is the fare, the bill of fare is to tell what the fare consists of; the menu is the "lay out," the bill of fare is the itemized description of the "lay-out," as if one should say, "this is my library; this is the catalogue of my library." People meet and discuss or enjoy the menu or fare, but they do not discuss the bill of fare. Nevertheless, by the elasticity of language, menu is used in the

same sense as bill of fare, and either word may be chosen with propriety; menu is thought to be the more stylish of the two and is oftenest preferred now to head the dinner list. In this connection it may not be out of place to remark that *cuisine* also has a double sense, meaning both kitchen and cooking; *la cuisine* is the kitchen, but when it is said that any hotel is noted for its excellence of its *cuisine* it implies the other meaning of the word—cooking. Many hotels reject the use of both menu and bill of fare, and head their bills with the word "Dinner." Others, again, follow the method of the annexed example and make the announcement of *table d' hote* (which is equivalent to our plain American "regular dinner") do duty instead of either term.

In regard to the examples of bills of fare here to be found, it must be explained that they are taken up by chance from a very large collection and are neither selected as models or otherwise, but are only the first that came to hand which happen to illustrate the particular point under consideration.

#### Metropolitan Hotel Restaurant.

Thursday, February 4, 1886.

#### TABLE D' HOTE 3 TO 7 O'CLOCK INCLUDING WINE, \$1.00.

	Oysters on half shell	
Consommé vermicelli	Mock turtle à la Française	
	Boiled halibut, lobster sauce	
	Potatoes Hollandaise	
	Smoked tongue with green kale	
Fricassée of chicken wings with oysters	Sauerkraut à la Francfort au jus	
	Fresh beef tongue braisée, sauce piquante	
	Spaghetti lié à la Napolitaine	
Ribs of beef	Turkey, cranberry sauce	
	Salad	
Stewed tomatoes		Mashed potatoes
Boiled rice		Peas
	Bread pudding, wine sauce	
Assorted cakes		Strawberry ice cream
	Assorted fruit	
	Médoc	
French coffee		English cheece
The very choicest selection of Cigars to be found in the City, for sale in Cafe.		
JOHN M. OTTER, MANAGER.		

## HEADINGS OR NO HEADINGS?

The above very excellent bill is strictly in accord with the opinions and teachings of the hotel press, unless an exception be taken to the cigar line at the bottom, and particularly so in regard to the small number of dishes, the absence of "relishes," and the absence of headings. Here is an example from a hotel in the extreme South, but under New York management and running at four dollars a day, which uses headings and includes "relishes," and there are good reasons on this side of the question, too.

## DINNER.

FROM 6 TO 8.

MONDAY, MARCH 16, 1885.

### SOUP.

St. Germaine. Consommé Printanier Royal.

### FISH.

Boiled Sea Bass, Sauce Hollandaise.  
Potatoes Parisienne.

### RELEVE.

Corned Beef and Cabbage.

### ENTREES.

Becassines en Salmi a l'Ancienne.  
Fricandeau of Veal, Bourgeoise.  
Spaghetti au Gratin, Piemontaise.  
Chocolate Fritters, Vanilla Sauce.

### ROAST.

Ribs of Beef. Ham, Champagne Sauce.  
Young Turkey, Stuffed.

### GAME.

Brant with Jelly.

### VEGETABLES.

Boiled Potatoes. Mashed Turnips.  
Green Peas. Baked Sweet Potatoes.

### RELISHES.

Horse Radish. Gherkins. White Onions.  
Chow-Chow. Lettuce. Olives.

### PASTRY AND DESSERT.

Steamed Raisin Pudding, Brandy Sauce.  
Apple Pie. Pound Cake. Chocolate Slices.  
Jelly Drops. Lemon Sherbet.

Apples. Oranges. Assorted Nuts. Raisins.  
Roquefort, Edam and Orange Co. Cheese.  
Crackers.

COFFEE.

TEA.

*Waiters are furnished with Wine Cards.*

All Dishes not on the Bill of Fare, and all Fruit or Lunch taken from Table will be charged extra. Guests having friends to meals will please register at office.

BREAKFAST FROM 7 to 10; SUNDAY FROM 8 to 11.

The writer of these lines prefers to use headings, always writes his bills that way,

considering that the hotel is an inn, a caravansary where people come as strangers, and the ways of the house should be made as plain as possible for them. Very few of these transients are "gastronomically educated," few of them, comparatively, have ever ordered from a bill of fare, and with a waiter standing by waiting for them to speak, they have trouble enough to order their meal intelligently even with the help of plain headings; the bill without headings must seem like a mass of dishes thrown together without order and without a purpose. Witness the following bill without headings, divisions or spaces, as it is found in a New York hotel paper. Possibly the original was better looking.

### VICTORIA HOTEL.

Blue Point Oysters  
Creme a la Windsor Consomme Napolitaine  
Fondu of Cheese on Toast French Sardines  
Saucisson D'Arles Celery Queen Olives  
Boiled Redsnapper, Sauce Flamande  
Potatoes Naturel Sautees au Beurre  
Turkey Boiled, Celery Sauce Smoked Jowl with  
Sauerkraut Loin of veal stuffed, Sauce  
Andalouse  
Sirloin of Beef larded a la Lithuanienne  
Lamb Chops Farandale  
Rice Croquettes with Apricots  
Sherbet au Citron  
Ribs of Beef Capon, Giblet Sauce Saddle of  
Mutton Spare Ribs of Deerfoot farm pork,  
Apple Sauce Red head Duck with  
Orange Marmalade  
Salads—Chicken Mayonnaise Lobster Potato  
Lettuce  
Pate de Foie Grass Truffe Boned Chicken with  
Jelly  
Plain Lobster Tongue Etc  
Boiled Potatoes Mashed Potatoes Boiled Onions  
Rice Peas Beets Spinach Baked Sweet  
Potatoes Squash Fried Oyster Plant  
Spaghetti Italienne  
Rice Pudding, Port Wine Sauce  
Cocoanut Pie, Green Gage Pie, Almond Slices,  
Gateaux Boston Cream Cakes Wine Jelly  
Vanilla Ice Cream.  
Nuts Raisins Figs Fruits  
American, Roquefort, Brie and Neufchatel Cheese  
Cafe

The reason given for omitting headings from the bill of fare is that it is more "tony" to do without them. Their absence implies a compliment to the guests by the supposition that they are "gastronomically educated," that they do know the proper order of dishes and the locality in which to look for them without any guiding signs. It will be seen, then, that the bill without headings is proper for select family hotels, but not best for commercial hotels, railroad depot hotels, nor for the generality of re-

sort houses. And if the bill without headings is desired in such establishments, the dishes should be few as in our first sample menu, so that they may be comprehended at once and the dinner selected with ease even by a stranger to hotel customs.

#### WHAT SHOULD THE HEADINGS BE?

The ordinary headings are soup, fish, boiled, roasts, entrees, vegetables, cold dishes, pastry, dessert. That is for common life without any pretensions to style, and the order of arrangement is as the people generally want it, in that order they take their dinner. And here it may as well be explained that pastry is not properly called dessert, although it is the general custom to apply the term dessert to all the sweets which constitute the second service of the dinner. "Pastry and dessert" is the most convenient form as it admits everything, but "dessert" alone means fruit, confectionery, very light sweets and ices. But where something above the ordinary is desired, when the meals and the menu are intended for something above the run of common life, more divisions appear and more headings. The first example menu and the second are alike in one particular, they make the "Boiled" appear before the "Entrees" and the "Roast" after them, and the second uses the word "Releve" instead of "Boiled," as would be the case in the first example were headings used in it at all. This arrangement is immaterial and merely a matter of literary taste, as the people for whom the dinner is prepared nearly always take all their meats, whether boiled, roasted, entrees or game, at one and the same time, and the vegetables of their choice with them. If the third example menu were properly strung out and the headings inserted, it would show cold *hors d'œuvres*, soup, hot *hors d'œuvres*, fish, relevés, entrees, sorbet, roasts, game, salad, and cold dishes, vegetables, pastry, dessert, thirteen headings besides cheese and coffee, which usually go as distinct items without headings, but which nevertheless make up the thirteen

courses into which such a dinner can be divided. The Victoria menu is faulty in respect to mixing the hot and cold *hors d'œuvres* or side dishes. Oysters raw, although somewhat of an American specialty, are but one of the cold *hors d'œuvres*, or appetizers, preliminary to the meal and no more entitled to stand alone than the others, "French Sardines — Saucisson d'Arles—Celery and Queen Olives," which all strictly belong in the same place as the oysters. The hot *hors d'œuvres* belong where the one in that bill appears; it is the "Fondu of Cheese on Toast," or Welsh rarebit. All of this style is, however, felt to be very cumbersome; it is difficult to handle all these formalities in strict propriety and the sensible thing is to drop the superfluities—there is no use for the hot *hors d'œuvre*, except in a formal course dinner, and that being omitted, such side dishes as sliced tomatoes, olives and celery are placed after the soup instead of it.

COMPLIMENTARY banquet given by Mr. Alderman Whitehead to Major and Sheriff Davies and a large number of the inhabitants of Cheapward, at the Guildhall Tavern, London, on the 26 of October. The catering was up to Messrs. Ritter & Clifford's best form, and the *menu* as follows:

HORS D'ŒUVRES.	
Haute Sauterne.	Sardines. Prawns. Caviare. Foie Gras. Olives.
Turtle Punch.	Clear Turtle. Thick Turtle.
	Soles à la Normande. Stewed Eels en Matelotte. Turbot, Hollandaise and Tartar Sauces. Fried Smelts.
Vino de Pasto. Rudsheimer Berg. Irroy, 1880.	Lobster Cutlets. Sweetbreads with Truffles. Salmi of Widgeon. Roast Turkey Poults. Ox Tongue.
Veuve Clicquot, 1880.	Boiled Capons and Cumberland Hams.
Piper's Tres Sec., 1880. Perinet et Fils, 1880. Pommery et Greno, 1880.	Saddle Mutton, French Salads. Braized Calves Head. Wild Ducks. Partridges. Mushrooms.
Claret. Château la Rose.	German Puddings. Curaçao Jelly. Maraschino Jelly. Chartreuse of Grapes. Swiss Pastry.
Sandeman's Old Port.	DESSERT. ICES. Lemon Water. Raspberry Cream.

If headings are used and *hors d'œuvres* appear under their proper head, they are not designated as hot or cold, however, for their place in the bill shows of which description they are, as the bill of fare on the preceding page illustrates. Had this been in the United States the first section would have been "Blue Point Oysters," and there might have been a total omission of all the other cold *hors d'œuvres*, just as in this bill there is a total omission of the vegetables, which of course they had, as not worth mentioning.

To be fair, however, here is an example where both classes of *hors d'œuvre* are printed after the soup, the "Bouchées Viennoises" being Vienna patties, a hot *hors d'œuvre*, as most of those small trifles are, which in our American bills are classed as entrees.

Menu of a dinner served at the Continental, Paris, being a banquet given to Hon. Geo. Walker by the Stanley Club. The dinner was of thirty covers, and this is what they had:

## MENU.

Consommé aux pointes et quenelles bisque.  
Hors d'œuvre variés.  
Bouchées Viennoises.  
Turbot, sauce crevettes et Hollandaise.  
Poulardes à la Chevalière aux truffes.  
Langouste à la Parisienne.  
Sorbet Jamaïque.  
Faisans et perdreaux sur croustades.  
Salade.  
Pâtés de foie gras de Strasbourg.  
Petits pois à la financière.  
Bomb Glacée vanille et abricots.  
Gâteau Havanaïs.  
Corbeilles de fruits. Bonbons.  
Petits fours.  
Xeres. Château Durcc. Château Clemens.  
Pommard. Bacherolles. Medoc en carafes.  
Champagne. Heidsieck. Monopole.  
Café et Liqueurs.

As, perhaps, not one in ten thousand in this country understand French, as applied to dishes in a menu, and as these articles are intended to be informatory, the above may be translated thus:

SOUPS—clear soup with Asparagus points and the thick soup which we call cream à la duchesse. HORS D'ŒUVRES—various (*variés*), as, for example, in the London bill preceding. HORS D'ŒUVRE—(hot) Vienna patties or *bouchées au salpicon*. FISH—turbot, with choice of two sauces, shrimp and hollandaise. ENTREES—chicken fried, truffle sauce, sea crayfish or small lobster in Parisian style. SORBET—with Jamaica

rum, perhaps a new name for Roman or rum punch. GAME—pheasants and partridges on ornamental fried toast. SALADS—not specified what kind. Raised pies of foie-gras (Strasbourg fat goose liver), green peas in sauce, moulded vanilla and apricot ice creams, Havana cake, baskets of fruit, candies, small cakes, wines, coffee and liqueurs.

## FIFTH AVENUE HOTEL, New York.

Oysters on half shell

## SOUPS.

Paysanne Clam

## FISH.

Boiled Haddock, shrimp sauce Baked Sole, Genoise  
Small Potatoes

## RELEVÉS.

Leg of Mutton, caper sauce Corned Beef and  
Cabbage Chicken and Pork Calf's Head  
brain sauce Beef Tongue Ham

## COLD DISHES.

Beef Tongue Roast Beef Ham Boned Turkey  
Lobster plain Chicken Salad Lobster Salad  
Lamb Head Cheese

## ENTREES.

Sirloin of Beef à la Bordelaise  
Snipe bardée sur croustade  
Epigramme of Lamb aux petits pois  
Bouchées of Oysters à la Reine  
Chicken à la Chasseur  
Cream Fritters, vanilla flavor

## ROASTS.

Chicken Ham champagne sauce Mongrel Duck  
Beef Saddle of Mutton Turkey

## Curaçoa Sherbet

## GAME.

Antelope

## VEGETABLES.

Boiled Potatoes Onions Stewed Tomatoes.  
Mashed Potatoes Beets Sweet Potatoes  
Hominy Fried Parsnips Turnips  
Spinach String Beans

## PASTRY AND DESSERT.

Suet Pudding, wine sauce  
Rice Pudding Sliced Apple Pie  
Cocoanut Pie Fancy Macaroons  
Holland Cake Charlotte Russe Ladies' Cake  
Almonds Oranges Raisins Pecan Nuts  
Apples Grapes Pears Bananas  
Hickory Nuts Figs English Walnuts  
Vanilla Ice Cream  
Coffee.

When, in the matter of these side dishes or of any other question of arrangement, there seems to be such diversity of practice even amongst the higher class of caterers, we come back to the fact that *there is such a thing as an American hotel bill of fare* that is a pattern to itself, and indeed is becoming a pattern to many on the other side of the Atlantic as numerous printed bills of their hotels show, and the old forms, which are

more perplexing than useful to follow, are in our bills of fare ignored and left over for those to carry out whose duties compel them to conform to foreign usages. The hotel named on preceding page will be recognized as a representative one and one of the largest size, yet its bill of fare is very faulty in arrangement, if it is to be judged by foreign rules; it is, curiously enough, the desperate effort to make an American hotel bill conform to a Parisian pattern, in reason and without reason, which makes it faulty, for it is neither the one nor the other; the curacoa sherbet, the antelope, the snipe and the salads are all out of their proper places beyond dispute, while other dishes and even divisions stand upon disputed ground.

But to finish the *hors d'œuvres* question: One object of inserting the Fifth Avenue Hotel bill on preceding page was to show that even the best hotels do not always enumerate such things as come under that designation, but if they do, the proper place for celery, olives, sliced tomatoes and similar cold trifles is after the soup. It is necessary to state this definitely because serious contentions often arise between steward and proprietor on just such questions, and there are some who maintain that such cold "appetizers" should be written in after the fish "to take away the taste of fish," as they reason. In the smaller hotels, where the cold trifles are placed on the table in advance to facilitate quick service and save waiters' labor, the particular line occupied in the bill of fare is of little consequence, but the best usage decides after the soup. For example:

HORS D'ŒUVRE.  
Oysters on half shell.

SOUPS.  
Clam Paysanne

Celery Olives Sardines Prawns Caviar

FISH.  
Boiled Haddock, shrimp sauce Baked Sole Genoise  
Parisian Potatoes.

SERVING POTATOES WITH FISH.

A cursory examination of the hotel bills of fare from all parts of the country will

show that the custom of serving potatoes in some fancy form with fish has become very general, so much so that a bill does not seem to be complete nor as stylish as it might be if that feature happens to have been omitted. It is a recent custom which originated in the famous restaurants of Paris, notably at Brebant's, for whom one of the forms of potatoes is named, that we designate *a la Brabant*. It comes quite as natural to eat vegetables with fish as with meat, yet foreign custom, and particularly English custom, has confined us heretofore to bread—generally brown bread—with that course. The ornamental addition of potatoes to the sauce is the more satisfactory, because the individual style of service of the present day shuts out most of the ornamental styles of dishes that used to be served whole. Potato croquettes and croquette balls, leaf, heart and star shapes of *duchesse* potatoes carefully egged over and baked, and, indeed, all the variations that are in use are great helps to the appearance of a plate of fish.

ALWAYS SERVE FISH ON SMALL PLATES.

New waiters generally have to be instructed on this point, as they are most apt to take a meat dish for fish. But if they serve it so, the person at table will slip it from the dish to his plate, and the dinner plate will then have to be changed for the meat course. Apart from that consideration, the fish looks better on a dessert plate, and it cannot be transferred to another without "mussing" it up with its sauce. The diner eats it from its own small plate, garnished as the cook sends it in.

WHICH FIRST, JOINTS OR ENTREES?

It will be observed that in all the example bills of fare thus far shown the roast meats appear after the entrees; in the first one the entrees come next after the fish, in the others the "fence is straddled" and the boiled meats precede entrees and roast meats follow them in another place. Here is a Scottish bill that looks a good deal like American style except that it has no vege-

tables or other minor mention, and in this, too, the entrees follow the fish. The correspondent writes:

"A presentation dinner was given by the Queen's Own Yeomanry Cavalry to their major on the occasion of his leaving for India. I got hold of the bill of fare—a good, healthy volunteer *menu*—which I now present:

Hare Soup.	Oyster Soup.
	Clear Oxtail.
	-----
	Turbot, Lobster Sauce.
	Dressed Cod, Oyster Sauce.
	Filleted Sole.
	-----
	Mutton Cutlets, Sauce Piquante.
	Sweetbreads with Mushrooms.
	Curried Rabbit.
	Suprême of Chicken aux Truffles.
	-----
Sirloin of Beef.	Haunch of Venison.
	-----
	Braised Turkeys, Celery Sauce.
Roast Chickens.	Yorkshire Ham.
	Ox Tongues.
	-----
Victoria Pudding.	Lemon Pudding.
Berlin Tarts.	Swiss Souffles.
Stewed Fruits.	Blancmange.
	Noyeau Jellies.
	-----
	Dessert.

Now, all of these try to follow the French custom of serving the entrees first, only because it is the French way, and those who split the difference and place boiled on top, entrees in the middle and roasts next, get the roast beef and such solid joints so far down, because the French roasts are placed there in French bills, without taking notice that such French bills never contain any plain boiled meats, nor plain roast beef, nor mutton. Their roasts (*rots*) are some choice kinds of small game, something that is considered better in some way than the made dishes or entrees. The French idea is that plain roasted or boiled meats are not good enough for a fine menu. (Look at the representative menu of the dinner given in Paris by the Stanley Club, a little way back—no boils or roasts are there.) Instead of crowding the English favorite boiled leg of Southdown mutton into that Parisian bill just under the turbot, and the American

favorite rare roast beef into the place occupied by pheasants and partridges *sur croustades*, we do better to make our own style of bill of fare according to the preferences of our own people, who, generally speaking, regard the joints as the principal part of a dinner and all the rest as little nic-nacks, very nice in their place, but of no great consequence.

Practically it does not make much difference whether the entrees or the boils and roasts are placed first in order, for experience shows that people choosing from a bill of fare nearly always select whatever meats they intend to partake of all at one time, boiled joints, roasted joints, entrees or game, and their favorite vegetables with them, without regard to the order in which they are ranged in the printed list; still it is most proper to place the substantial meats before the entrees, in conformity to the principles laid down by the French gastronomers themselves.

Here is the ideal menu embodied in a recent sketch by a *feuilletonist* of the day, "Max O'Rell." He depicts a little party of three or four "gastronomically educated" individuals, Paris gourmets, in fact, seriously engaged in the absorbing question what to order for dinner at the fashionable restaurant, where they are seated, and the subjoined shows the outcome of their deliberations:

"Consommé aux pois.  
Oysters and a sole Normande.  
Pheasant à la Sainte-Alliance.  
Châteaubriand.  
Tenderest of asparagus à l'Amazone.  
Suprêmes de mauviettes.  
Ortolans à la Provençale.  
Meringues à la vanille.  
Ice, cheece, dessert."

But it is easy to see that "Max O'Rell" has been studying Brillat Savarin and the *Physiology du Gout* for his purpose; the dishes are Savarin's favorites, the "pheasant *a la Sainte-Alliance*" was his own invention, the menu is necessarily good and, which is most to the point, its arrangement of dishes in place is according to one of the axioms laid down by that much admired



teacher that the order of dishes should be from the plain and substantial to the more light and delicate, the motive being to prolong the pleasure of eating by leading on from dish to dish, from good to better and best. In this the ideal menu of this literary man is precisely the same as the best specimens of the American hotel bill of fare. After the soup and fish comes the roast pheasant, equivalent to our every-day roast chicken or turkey stuffed; the chateaubriand, which comes next, is the fillet of beef, with natural beef juice for its sauce; it is to all intents the same as our roast beef and the nearest thing to plain roast beef that a proper Parisian menu ever shows. More delicate and more piquantly seasoned than those are the larks and then the ortolans, the fattest of small birds, and called the choicest morsel that is known to epicures. According to that rule, our entrees, seasoned, flavored and spiced, decorated to tempt the appetite that is already satisfied with plain food, should be placed after the substantial boiled and roasted meats, instead of before. And yet we would not have every bill look alike.

#### THREE ROYAL EXAMPLES.

Not to depend upon the idealism for high sanction, however, the following menu of an actual affair shows a pretty good pattern of the American style; that is of the essential part, for these menus never mention the vegetables unless they are made into a good dish such as we call a vegetable entree and they call entremets, just as our bills never mention bread unless it is made up into some form like croustades, sippets or toast:

"Gala dinner served at Prince Fürstenberg's palace, at Kremsier, to the Emperors of Austria and Russia and seventy-six guests. The table was laid with the costly service of gold plate from the Imperial Palace of Schönbrunn. The following menu was placed before the illustrious diners:

Tortue Claire.  
Bouchées à l'Empereur.  
Filets de Saumon à la Cardinal.  
Pièce de Bœuf et Selle de Veau.  
Suprême de Poularde à la Financière.  
Chaufroid de Cailles.  
Sorbet.  
Selle de Chevreuil, Salade et Groseilles de Bar.  
Fonds d'Artichauts à la Demidoff.  
Pouding à la Crème de Vanille.  
Gelée au Muscat Lunel.  
Fromages. Glaces aux Noisettes. Dessert."

There is a clear turtle soup; a hot *hors d'œuvre*; fillets of salmon with a sauce made red with lobster coral; a piece of beef and saddle of veal, roasted of course; a rich fricassee of chicken, white, and a rich fricassee of quails, brown, for the entrees; then punch. Next, the game, saddle of venison with currant jelly and a salad, and artichoke bottoms for the vegetable to eat with it. Then a vanilla cream pudding, muscat wine jelly, cheese, ices, nuts and fruit. The piece of beef and saddle of veal above the entrees is the feature that makes it like an American bill of fare and different from French bills, and it has a familiar appearance all through.

"The following is the bill of fare of a nice little dinner given by the Archduke Joseph of Austria to a select party of guests at his charming country seat on Marguerite Island, on the Danube, near Buda-Pesth. Count Zichy presided, the Archduke being prevented from appearing at the table owing to his being in court mourning:

#### MENU.

Potage à la Colbert.  
Pièce d'esturgeon, sauce remoulade.  
Filet de bœuf à l'Anglaise.  
Bouchées à la Reine.  
Perdreux rôtis.  
Salade Française.  
Turas-Haluska.  
Glace panachée.  
Café. Liqueur Zichy. Crème.

Partaken of to the melodious accompaniment of a band of Tziganes (Anglice, Hungarian band), and washed down with various bottles of Hungarian wines, amongst which reigned supreme a regiment of Imperial Tokay, 1834."

There is a soup to be found in American bills any day; piece of sturgeon with a variation of tartar sauce, or mayonaise with minced pickles in it; fillet of beef in English style, which is plain roasted with mushrooms; only one entree, which is a patty that might do equally well as a *hors d'œuvre*; then roast partridge and a French salad. *Turas-Haluska* is a Hungarian pudding; then comes tri-colored or Neapolitan ice cream and dessert.

"Menu of a September lunch served at Mar Lodge upon the occasion of the Prince of Wales' visit to the Earl of Fife:

Consommé de volaille.  
 Turbot crème au gratin.  
 Salmis de grousses à la Mar Lodge.  
 Poulets à la Viennoise.  
 Filet de bœuf Bordelaise.  
 Quartier d'agneau rôti, sauce menthe.  
 Perdreaux rôtis.  
 Petits pois Français.  
 Souffle Béarnaise chaud.  
 Mousse au café."

In that there is a quarter of lamb, roasted, with mint sauce, and a fillet of beef. The arrangement of dishes is slightly different from others, due to the preferences of the French *chef* who prepared the menu. The last dish named is a coffee-flavored whipped cream, a froth.

These selections are more than mere interesting reading; they may serve as examples for occasions which are continually arising in our hotels when traveling dignitaries and celebrities are to be entertained, and they show that it is *not* the proper thing then to make the bill of fare twice as long as it usually is made for common use. But to return to the ordinary hotel bill:

#### THE PLACE FOR THE COLD MEATS.

Those who wish to find good authority for placing the small side dishes of cucumbers, celery, etc., after the fish instead of before, with the idea of "something to take away the taste of fish," have excellent patterns to follow in the three hotel bills of fare here following. A person having to decide what form to adopt could hardly do

better than take either the first, which is from the Bates House, Indianapolis, or the third, which has the name of the hotel attached. The latter shows another way of putting in those little dishes, "small onions" and "olives" appearing in smaller type after the entrees, while "celery" follows the fish.

## DINNER.

### OYSTERS.

New York Counts

### SOUP.

Mulligatawny Consommé

### FISH.

Striped Bass, Madeira Wine Sauce  
 Boiled California Salmon, French Peas  
 Potato Croquettes

Spanish Olives Sliced Tomatoes Olives

### BOILED.

Fowl, Oyster Sauce  
 Leg of Lamb, Caper Sauce

### ROAST.

Sirloin of Beef  
 Young Turkey with Dressing  
 Cranberry Sauce

### ENTREES.

Tenderloin of Beef, Larded, Tomato Sauce  
 Sweet Breads, Braised, Mushrooms  
 Banana Fritters, Rum Flavor

### GAME.

Roast Pheasant, Bread Sauce  
 Mallard Duck, Plum Jelly

### CHAMPAGNE ICE.

### COLD.

Celery Salad Mayonnaise of Chicken Lamb  
 Smoked Beef Tongue  
 Roast Beef Crab Salad

### VEGETABLES.

Mashed Potatoes Boiled Potatoes  
 Steamed Rice  
 Cauliflower Stewed Tomatoes Red Slaw  
 Jersey Sweet Potatoes Baked

### PASTRY, ETC.

Oriental Pudding, Steamed, Brandy Sauce  
 Lemon Meringue Pie  
 Mince Pie Charlotte Russe  
 Almond Macaroons Fancy Assorted Cake

### VANILLA ICE CREAM.

Raisins Mixed Nuts Figs

### Fruit in Season

Edam and New York Cream Cheese Crackers  
 Coffee.

These trifling variations show how bills may differ without being wrong in arrangement. The middle one of these three bills of fare is from the Sherwood, a fashionable hotel in New York; it shows cucumbers after the fish, not because that is the place chosen for the cold *hors d'œuvres*, as some of them appear lower down under the head of "mayonnaise," but for the reason that it is proper, according to French ways, to serve cucumbers with fish. But suppose one has an antipathy and cannot eat sliced cucumbers with the French, is it not equally proper to eat sliced tomatoes with the Americans? And if both cucumbers and tomatoes are proper why not celery, also, and olives? The inquiring reader is to remember that these momentous questions can never be definitely settled—never so long as the world stands, but there may come a moment sometime in the midst of a heated debate when he will thank us for giving him this argument and the Sherwood bill of fare, which illustrates it.

**DINNER.**

Tuesday, March 1, 1887.

Blue Point Oysters on Half Shell

SOUP.

Chicken with okra      Consommè

FISH.

Boiled Halibut, anchovy sauce  
Cucumbers      Potatoes

BOILED.

Corned Beef and Cabbage

REMOVES.

Ribs of Beef      Chicken      Leg of Mutton

Cold Meats, Etc.

MAYONNAISE.

Chicken      Feticus      Lobster      Lettuce  
Tomato      Cold Slaw

ENTREES.

Fillet of Beef, sauce Béarnaise

Calf's Feet à la Poulette

VEGETABLES.

Macaroni à la Milanaise      Bermuda Potatoes  
Rice      Tomatoes      Oyster Plant, fried  
Mashed Turnips      Cream Spinach

DESSERT.

Boiled Apple Dumpling, brandy sauce

Peach Pie      Charlotte Russe      Assorted Cakes

Orange Water Ice      Vanilla Ice Cream

FRUITS      NUTS      CHEESE      COFFEE

An extra charge will be made for dishes ordered not on the bill of fare.

DINNER FROM 6 TO 7.30.

**MENU.**

SOUP.

Green Sea Turtle, à l'Anglaise      Consommè Royal

FISH.

Baked Florida Trout, aux Fines Herbes  
Celery      Potato Croquettes

BOILED.

Corned Beef and Cabbage

Leg of Southdown Mutton, Capers Sauce

ROAST.

Ribs of New York Beef, with Yorkshire Pudding

Sirlon of Beef, with Browned Potatoes

Young Chicken, Stuffed, Giblet Sauce

Sugar Cured Ham, Sherry Sauce

ENTREES.

Tenderloin of Beef, Saute, with Mushrooms

Calf's Head, à la Toulouse

Apple Fritters, Glace au Rum

Olives      Small Onions

COLD DISHES.

Roast Beef      Ham      Corned Beef      Shrimp Salad

VEGETABLES.

Boiled Potatoes      Mashed Potatoes

Carolina Rice      Stewed Tomatoes

Sweet Potatoes      Extra Sifted Peas

Vegetable Oyster Plant, Cream Sauce

Asparagus.

PASTRY AND DESSERT.

Fruit Cake, Glace au Rum      Lady Fingers

Almond Macaroons

Meringues, à la Parisienne      Peach Pie

Vanilla Custard, au Meringue

Steamed Cabinet Pudding, Claret Sauce

Ice Cream, au Muscat

FRUITS.

Apples      Oranges      Bananas      Raisins

Dates      Assorted Nuts

Edam and Cream Cheese      Wafers      French Coffee

Japan and Gunpowder Tea

Sweet Milk      Butter Milk

KIMBALL HOUSE, Jan. 9, 1887.

But the real object of introducing these examples is to show the best place to locate the cold meats, that is at the end of all the other meats; if entrees are the last let cold meats follow them, if game appears after the entrees let cold meat come after the game. The Fifth Avenue and the Sherwood have them higher up, and they do not look so well up there dividing the hot meats. That is about all the argument there is in the case, for this division is the *bête noir* of the tasty bill of fare writer. The majority of hotel caterers try very hard indeed to twist their *table d'hôte* bill into the shape of the French course dinner bill, with its sorbet or punch in the middle and its game after the punch and salad after the game; and they manage that far very well, but when the cold meats division has to come in they are at a loss;

the Parisian course dinner has no cold meats division so they have no guide. But the hotel customers don't care a fig about that, and want cold meats just the same. As caterers to the tastes of hotel patrons we have but little concern with their motives, but we know from experience that no matter what the hot meats may be some few out of a number always call for the cold cuts. It may be that at the mid-day dinner some people restrict themselves to selecting only a lunch, taking their hot meal at supper time, or, at evening dinner some people allow themselves only a light supper, letting all the rich and savory hot dishes severely alone at that time of day or night. The "cold meats" division, therefore, has to be tolerated; the only thing to be done is to fill it with but few items, and one or more should be of the rich and ornamental sort—aspics, mayonaises, boar's head, galantines, raised *patés*. The inquiring reader should note in these examples the two different ways of placing the date: with and without the day of the week; at top and at lower left-hand corner; and the subsidiary lines, and also that all three have headings to the different divisions, and at the same time make no mention of "relishes." Attention is also directed to the example of two New York hotel bills—the Sherwood here and Victoria in a previous article of this series—in serving macaroni and spaghetti as a vegetable, or with the vegetables; that is not an oversight, misfit or mistake, but all those dishes are properly classed as *entremets* by those who wish to have things that way; so are puddings.

#### CURRENT CRITICISMS.

In one respect, at least, the writer of these lines has always been misunderstood by some readers. He has never denied that the French are the leaders of the fashions in dining as well as in other things, but has denied that French fashions are applicable to American hotel dinners. He has never denied that the French know more about cooking, taking them as a

people, than any other people; but has always contended, and contends yet, that to adopt strictly French cooking in an American hotel would drive most of the customers away. This is not supposition, but observation and experience. The French cooks themselves make the same observations and go back to France in disgust, complaining of a lack of appreciation, or else, if they stay here, they change their ways somewhat to suit our people.

But yet, if some amongst our hotel patrons will follow French fashions and dine upon fashionable dishes in fashionable formality we, as hotel caterers, are required to understand the subject with all the whys and wherefores, and for that reason these different samples of bills of fare are presented, showing different forms; only presenting one line of opinion, viz: that while French cooking and French ways are the very best *for the French*, we need a little different system, because we are a different people and do not like the same things in the same ways as they do. The real point of contention, and where the writer may possibly appear to be eccentric, if not original, is in this: that while most of the fine writers and would-be gastronomical educators say, "But you ought to do thus and so *because* the French do so," the argument of these articles has always been: let the French go their ways; few of us like their oil, their garlic, their glaze, their espagnole, their nutmeg (in meats and potatoes), their herbs, their thin soups, their anchovies, their snails, their many things, and we cannot help these likes and dislikes in food. The French say we can not have good cooking unless we employ French cooks at their own prices, but we will say we will educate our own cooks and see what French, Italian, German and Spanish cooks know, that we want; and will adopt so much of their knowledge as is applicable to our own people, and leave the rest. The above is partly in answer to criticisms. There are some partisans who are disappointed when there is not a fight, and they look for a running down and de-

preciation of every French form only because it is French, and because they do not understand it. That would be extremely ridiculous. The object of these writings is to show the meaning and the merits of other people's fashions that we may hold fast that which is good and agreeable, and leave the remainder for them that like them, although we do not like them ourselves. If it were necessary to adopt some other country's fashion for a model the Italian bill of fare would come nearer to our predictions than the French. It is from the Italians we get our "sweet entrees;" our favorite "fritter" is the *fritto* of the Italian bill of fare, an indispensable course in every Italian dinner. The best known names among the noted cooks and caterers of New York are Italians; the fancy cake and confectionary business of London is largely in the hands of Italians—it is almost given up to them; and it does not follow that because they are excellent in some branches of the art we should make our bill of fare all of the Italian pattern, nor made up all of Italian dishes any more than French, although a steward, having to provide for the entertainment of a distinguished party of Italians, may be very glad to have the following example for a guide.

The following is the bill of fare of a dinner of a national character, prepared for Italians by an Italian, and it helps to explain why some of our American hotel bills of fare are formed as they are; it is the mixture of Italian with French ways. The employment of fine Italian cooks in many hotels causes the bills of fare of such hotels to be really Italian in form, and therefore seem to be wrong when compared with French patterns, and hence some of the apparent confusion, and hence another argument in favor of adopting a distinctly American bill of fare:

A REPRESENTATIVE ITALIAN BILL OF  
FARE.

Banquet to Signor Salvini, given by the Italian Colony in London, at the Panton

Hotel (proprietor, Mr. R. Pratti). Covers laid for fifty. Dining room profusely decorated with flowers and with Italian and English flags.

MENU:

Ostriche Native.

ANTIPASTO.

Caviale, Sardine, Salame, Tonno, Selleri, etc.

ZUPPA.

Ravioli al Brodo. Risotto con Tartuffi.

FRIITO.

Frittura Mista.

PESCE.

Salmone Bellito, Salsa alla Genovese e Salsa Hollandese.

ENTREES.

Pollo Saute alla Salvini.

Animelle di Vitello alla Minuta con Tartuffi.

PUNCH ALLA ROMANA.

Asparagi alla Milanese.

Aspic d'Aragosta alla Garibaldi.

ROSTO.

Agnello allo Spiedo.

Insalata assortita.

SELVAGIUME.

Quaglie rostite.

DOLCE.

Zabbaglione.

Ananas all' Orientale.

Croccante di Amandole.

Gelati alla Napolitana.

Gateau alla Vanille.

Petits Souffles all' Indiana.

DESSERT ASSORTITO.

Caffe e Liquori.

VINI.

Sauterne.

Chianti. Barolo.

The first dish above named is not ostrich, but oysters—English "natives," raw, of course, and it is very rarely that a French menu is formed that way, for the cold *hors d'œuvres* here follow the oysters under another heading; the Italians call them *anti-pasto*, and regard them as much a necessary part of a good dinner as the soup or fish. After them the soup, and after the soup the hot *hors d'œuvre*, which Italians call the *fritto*. After that the fish with two sauces but no potatoes, the fancy form of potatoes with fish seeming, therefore,

not to be an Italian fashion. After the fish comes the entrees, just as seen in so many New York bills, and after them the punch, which is according to French fashion as well. The cold dishes following the punch is just like some New York bills of fare and still more are the two next divisions where there are roast lamb and assorted salads in the same place as the French *roti* and *salade* would be, but is different in having still another "game" division for the roast quail. All the rest are sweets and wines.

#### THE DINNER IN COURSES.

Perhaps a better illustration of the form of making up an American-French course dinner could not be found than the annexed novelty, which turns up at the right time to verify the foregoing statements. The principal difference betwixt this and the *table d'hote* form is that nobody can choose which dish they will take and which they will pass by in the course dinner, but each one is served the same, while at *table d'hote* each individual may choose one thing or twenty, at discretion. This was an annual dinner of an association of traveling men held at the Metropolitan Hotel, New York. The menu is written in imitation of a railroad ticket, with coupon attachments, and must be read from bottom to top, the first coupon to be torn off being the first course, of which there are ten in all—from Drawing Room to Oysters; from Oysters to Soup; from Soup to Hors d'œuvre; Hors d'œuvre to Fish (with potatoes and cucumbers); from Fish to Releve; from Releve to Entrees; from Entrees to Punch; from Punch to Roast and Salads; from Roast to Pastry and Creams; from Pastry to Fruit, Cheese, Coffee and Liqueurs. It will be noted that the wines appear with the dishes. "Old Reserve" is sherry with the soup. The aptness of the quotation under the hot *hors d'œuvre* consists in the word mouthful, *bouchee* means mouthful. This is termed an American-French menu because it has Blue Points, Diamond-back Terrapin, Kennebec Salmon, Red-head

Duck ("dear," too) and a good deal of French language. But it is a good pattern:

#### CAFE AND COGNAC TO A FLOW OF SOUL.

"Serenely full the epicure would say—  
Fate cannot harm me, I have dined to-day."  
—Sidney Smith.  
"And all the people said—'AMEN.'"

#### ENTREMETS TO FRUITS.

Fromage, Cafe, Cognac and Liqueurs

"Spirits, which by mine art I have from their confines call'd  
to enact  
My present fancies."  
—"Tempest," Act IV, Scene i.

#### ROTI TO ENTREMETS.

Pudding à la Reine au Cognac  
Jelly au Champagne  
Bombes à la Windsor      Petits Fours.

"I will make an end of my dinner, there's pippins and cheese  
to come."  
—"Merry Wives of Windsor," Act I, Scene ii.

#### PUNCH TO ROTI.

Red-Head Duck      Lettuce  
Chambertin

"O, dainty duck! O, dear!"  
—"Midsummer Night's Dream," Act V, Scene i

#### ENTREES TO SORBET.

Punch au Kirsch

"Is it a party in the parlor?  
Crammed just as they on earth were crammed.  
Some sipping punch."  
—Wordsworth's "Peter Bell" (Suppressed passage).

#### RELEVE TO ENTREES.

Supreme of Chicken, à l'Imperial  
Petit Pois Francaises  
Diamond-Back Terrapin à la Maryland  
Champagne

"This lapwing runs away with the shell on her head."  
—"Hamlet," Act V, Scene ii.

#### POISSON TO RELEVE.

Filet de Bœuf pique aux Truffes  
Haricots Verts      La Rose

"If you give me any conserves, give me conserve of beef."  
—"Taming of The Shrew" (Introduction).

#### HORS D'ŒUVRE TO POISSON.

Kennebec Salmon à la Hollandaise  
Concombres      Pommes, Parisienne  
Haut Sauterne

"She, that in wisdom never were so frail,  
To change the cod's head for the salmon's tail."  
—"Othello," Act II, Scene ii.

## POTAGE TO HORS D'ŒUVRE.

## Petites Bouchées à la Montglas.

"... plays and tumbles, driving the poor fry before him,  
and at last devours them all at a mouthful."

—"Pericles," Act II, Scene i.

## HUITRES TO POTAGE.

Cream of Celery aux Croutons  
Consommé, Colbert Royal  
Old Reserve

"Mingles with the friendly bowl,  
The feast of reason and the flow of soul."

—Pope's "Imitation of Horace."

## SALON TO HUITRES.

## Blue Points

"The banquet waits our presence, festal joy  
Laughs in the mantling goblet, and the night  
Illumin'd by the taper's dazzling beam,  
Rivals departed day."

—Brown's "Barbarossa."

Another good example of the course dinner, right side up, is that Parisian menu, printed in a former article, of the Stanley Club; incomplete, however, in not naming vegetables.

Complimentary banquet tendered to the New England Grocers at the Grand Central Hotel, New York, Tuesday afternoon, Nov. 1st, at 2 o'clock:

Blue Point Oysters on the half shell

## SOUP

Green Turtle

## FISH

Filet de Sole au gratin à l'Italienne

Potatoes Brabant

## RELEVE

Filet of Beef pique à la Bordelaise

Potatoes Parisiennes

Cream Spinach

## ENTREE

Chicken Croquettes à la Toulouse

String Beans

## ROAST

Stuffed Turkey, Cranberry Sauce

Baked Sweet Potatoes

## PUNCH

Punch à la Romaine

## GAME

Roast Partridge

Celery Mayonnaise

## PASTRY

English Plum Pudding, Hard and Brandy Sauce

Vanilla Ice Cream

Mixed Cakes

Apple Pie

Pumpkin Pie

## DESSERT

Nuts and Raisins Ice Cream

Roquefort Cheese

Bent's Biscuits

Fruit

Coffee

For a good practical example of a dinner in courses the preceding may be taken. It is open to criticism on some points, such as using the French spelling of filet instead of English fillet, and in another respect, perhaps not worth naming, but it happily adapts American favorite dishes, such as roast turkey and sweet potatoes, to the uses of an unfamiliar form of service. It is to be observed that in a course dinner each dish of meat and game, as well as fish, has its own vegetable accompaniment, and the vegetables are not to be bunched together as they are in the *table d'hôte* bill of fare.

## THE SORBET OR PUNCH.

There is a growing desire among proprietors and stewards, who endeavor to set the best tables, to adopt the punch, which appears in the middle of the French course dinner bill, between entree and game. The example may be noted in several of the bills of fare shown in preceding articles, and the usually selected place for it is there seen, likewise. It is no longer always Roman punch, nor frozen punch, but after all these have had a run some stewards have taken to serving champagne cup, claret cup, Balaklava cup, and all the punches with fine names which can be found in the "barkeepers' guides." Some of these are poured from pitchers or decanters into the guest's glass that is already set upon the table. The various frozen punches—which are never quite solidly frozen—should be served in deep punch glasses, cup shaped, with handles.

There is a strong argument against the serving of punch gratis, however, in that it tends to lessen the sale of wine and bottled ale and beer, which some hotel keepers find a source of profit equal at least to the cigar stand, which in many houses is sufficient to pay the rent. It is argued that to give the diner a glass of rum punch with his dinner takes away his desire to order anything from the bar, and where the addition of wine to the dinner is offered as an advertisement, to introduce a sorbet or punch would be injudicious.

“THOSE EVERLASTING RELISHES.”

This is a minority report. There is almost always a minority that disagrees; sometimes the minority is called a respectable one, and it is allowed to present a report even after the question has been decided against it. It is decidedly in bad taste to include “Relishes,” with big black letters, as a heading in a bill of fare, and being in bad taste it is wrong, and is so acknowledged by nearly all, for the finest Sunday bills and Christmas and New Years bills, which are sent out for show, seldom include any “relishes”; yet a minority of those who send them out put “relishes” on their bills the very next day, and every day, for the home folks and for that class of travelers that wants a large and plentiful-looking bill for so much a meal. A part of this minority runs “relishes” in order to encourage manufacturers of table delicacies, inventors of new table sauces, importers of foreign novelties, purveyors of pure oils, the makers of all that glittering array of finely bottled and artistically labeled goods which makes the shelves of the dealers in fancy groceries the handsomest display in the city; and, as there is no limit to the enterprise of some hotel keepers and stewards, who make the excellence of their table the pride of their life, they constantly look over the columns of their hotel papers to see what new oils, catsups, soys, chutneys, salad dressings, fish sauces, flavored vinegars, or whatever else have lately come into use and fashion, and to find the places to buy them. Others still, belonging to the minority, grow very tired of catering to people who are not, in the mass, gastronomically educated, and they try to educate their customers to a point beyond Worcestershire sauce by placing on their tables such things as mushroom and walnut catsups, Bengal and Madras chutneys, chili-colorado, Tabasco sauce, anchovy essence, Harvey’s sauce, India soy, tarragon vinegar, and compounds of that class to the number of about fifty, in turn, and when they find the bottles

remain untouched, or scarcely a bottle used up in a year, because these are such mysterious things, they put the names of such “relishes” on their bill of fare, knowing that as everybody has read about everything in this land of newspapers, their boarders and visitors will thus be led to appreciate the provision made for their more luxurious dining.

The fight against “relishes” in the bill of fare has never been made against the refinement of the table, however, but was, and is still, directed against the silly “padding out” of the bill to make it look big and plentiful, though there is nothing in it; against such parades as used to be met with often, as: “Plain Pickles, Mixed Pickles, Stuffed Pickles, Spiced Pickles, Cucumber Pickles, Sharp & Soursauce’s Celebrated Piccalilli,”—which would all be strung out in one bill, followed by “Plain Mustard, French Mustard,” and a lot more such stuff, and this brought the whole department of relishes into disrepute. In this connection it must be noted again, and still on the side of the minority, that recent innovations in setting the table have done away with the chance of the guests seeing what they want when the bill of fare does not mention it. The best of the first-class hotels now have no cruet-stands on the tables, but, instead, a small regiment of tiny ornamental vases, decanters, jugs, pitchers, *amphoræ*, *ampullæ*, of china—such things as are found on the ornamental shelves and in the show-windows of the dealers in hotel china; these hold the various accessories of condiments and relishes, and yet give no outward token of their contents; the guest cannot be sure that even his familiar Worcestershire sauce and tomato catsup are there until he gets acquainted; he must either learn them from daily use, or ask the waiter, or come and go in ignorance of the fact that the thing wished for was so near, or else the bill of fare must tell him. There is no need of a heading for “Relishes” to tell this; one line across the bill might be introduced to tell all that is worth telling.



The line might be in smaller type than the main body of the bill, as has been shown in several bills printed on preceding pages.

## SPECIMEN IRISH BILL OF FARE.

This specimen banquet bill from Ireland is very much like an American bill, and remarkable for being in plain English. There are too many kinds of meat for any use, as if they had learned that bad habit from our hotels, and it does not regard the vegetables worth naming; but the vegetables over there are said to be poor and scanty—not like ours:

Banquet given by the Mayor of Londonderry (Sir R. McVicker, J. P.) to the Honourable the Irish Society. The dinner was provided by Mr. James Johnston, a well-known local caterer, and served in Corporation Hall:

## SOUPS.

Clear Turtle, à la Reine.  
Green Pea

## FISH.

Turbot—Lobster Sauce  
Salmon—Parsley and Butter.  
Filets of Soles, à la Maitre d'Hotel.

## ENTREES.

Lobster Cutlets. Lamb Cutlets and Peas.  
Sweetbreads—Mushroom Sauce.  
Veal Cutlets — Cucumber Sauce.

## REMOVES.

Roast Chicken      Roast Turkey Poults.  
Roast Beef. Roast Haunches Mutton. Roast Lamb.  
Boiled Chicken.      Green Goose.  
Hams.      Tongues.  
Grouse—Lobster Salad.

## ENTREMETS.

Marmalade Pudding.      Fig Puddings.  
Sultana Pudding.      Jellies.      Victoria Cream.  
Apple and Greengage Tarts.

## DESSERT.

Pineapples, Grapes, Greengages, Melons, Apples,  
Pears, Plums, etc.

## ICES.

Lemon Water and Strawberry Cream.

## SPECIMEN ENGLISH COMMERCIAL HOTEL BILL.

Somebody in an English city has opened a hotel specially for the commercial travelers' trade (doesn't say whether "sample rooms on the first floor," or "the best in

town"), and this is one of the bills of fare of the dinner served at fifty cents:

## SOUPS.

Mock Turtle, Julienne, Vermicelli.

## FISH.

Salmon, Halibut, Stewed Eels.

## JOINTS.

Roast Beef with Yorkshire Pudding,  
Boiled Leg Lamb, Ducklings, Spring Chickens,  
Pigeon Pies.

## ENTREES.

Curried Rabbit, Fricasses of Chicken,  
Lamb Cutlets, Beef à la mode.

## LEGUMES.

Potatoes, Peas, Spinach, Beans, Vegetable Marrow.

## ENTREMETS.

Iced Venice Pudding,  
Raspberry and Red Currant Tart,  
Pineapple Fritters, Black Currant Pudding.

## CHEESE.

Gruyere, Wensleydale, Cheddar.

## SALAD.

Cheese and salad are expected to create a demand for ale and beer or hot cups of some kind.

## HOW MANY DISHES?

A glance over a number of hotel bills of fare of the same date will show that a great difference of opinion exists on this point, even to go no farther than New York, for the makers of the bill of one large and wealthy establishment think it worth while to enumerate every kind of nuts and such small items, as well as all the sorts of cold meats besides a long list of entrees, while another presents only about one-third as many, and there is no reason to suppose that ideas of frugality form the leading motive for the smaller display. But there is no doubt that it requires "more nerve" in a man to set out a small bill of fare while expecting to compete with another house displaying a very voluminous one, on account the constitution of the general public, which is apt to look for quantity first, and the obtaining of a large amount for its money. The advocates for a fewer number of dishes properly claim that it is in better taste and that a small number of viands can be better cooked and served than the interminable list of things pro-

mised by some bills, and that a freshness in the daily change of dishes is attainable with a small list that is not possible when everything appears in the bill at once, day after day. It used to be urged in favor of the long lists of the great hotels, especially of the seaport cities, that they offered in their great variety something to suit the national taste of every foreign visitor; that the cooking was of a cosmopolitan character and each guest could select from the abundance offered to suit himself, not being restricted to the limited offerings of fare provided for the provincial customer. But of late years it has become a feature of the business for every large hotel to have a restaurant attached, some have two, called respectively restaurant and *cafe*, so that whoever is not fully satisfied with the hotel table can indulge his particular habits and fancies at one of these. The sound policy in regard to this question, as in many others, lies in the adoption of the golden mean, though some hotel men like to run to extremes. One says: "If I must provide forty pounds of meat I may as well have ten different kinds of four pounds each as to have but two of twenty pounds each, and in the same way he says it is as easy to have a little of ten different vegetables as to have much of only two kinds, and the six pies may as well be of six different sorts as to be all of one; then everybody can have what they like best and it makes no difference to me." But that old argument is fallacious. There is just enough truth in it to warrant a reasonable variety in the dinner, but, in fact, the expensiveness of a meal increases according to the increase of the number of different items; there is a certain inevitable waste in every separate operation in cooking; a portion of everything will be left over and lost, instead of a portion of only one or two things, and the more things are offered the more some of the guests will order, if only to "sample" and waste them.

It is in favor of a reasonable variety in the viands to remember that some kinds must cost less than others, and every order

made on the cheaper dish lessens the run upon the dearer one, and, again, it often happens that the cooking capacity of a place is not sufficient to provide enough of the one or two articles and half a dozen more of other sorts must come in to divide the calls; the same reasons obtain when the favorite article cannot be procured in sufficient quantity to stand all the pressure alone, then it has to be offset with something else almost equally in demand. These considerations, and others like them, have far more weight with those practically engaged in the preparation of the meals than any ideas of whether a greater or less display is in the better taste.

#### ONE SOUP OR TWO?

The soup question is one, again, of "gastronomical education." The general public, as we know it by hotel contact, demands thick soup, and all thin soups, clear soups, *consommés*, are repelled as insults to a good appetite, as signs of stinginess, as "dishwater." But writers like Sir Henry Thompson, author of "Food and Feeding," are opposed to thick soups, especially to cream soups, at least as preliminary to a dinner, because they take the appetite away. And yet thick soups are very good indeed, and among the best things which the best cooks can produce, and the cream soups are the prime favorites; it is not the soup, but the proper use of it which should be considered. An impecunious or frugal-minded man with fifteen cents in his pocket may step into a Chicago restaurant in the proper season and obtain for that sum a bowl of genuine turtle soup, of more than a pint, thick with meat, and a plate of bread accompanying it, and of that he makes a meal, a good wholesome meal, and walks out unburdened by over-feeding and in good trim for business or labor. But if, after the soup, even though in small quantity, he should seriously set himself to consume his share of a complete hotel dinner he would do himself an injury, and if the dinner were his primary object he should take only a thin soup, the thinner the better.

The human stomach will hold but a quart of semi-solid food, but liquids are absorbed and out of the way immediately. Doctor Andrew Coombe, himself a victim of hereditary dyspepsia, some forty years ago went to a French watering-place to study the subject of the "Stomach and its Difficulties," and seeing how some patients would drink as much as ten pints of spring water before breakfast and then without any diminution of appetite would straightway go and eat a full meal, understood that the water was immediately absorbed through the coats of the stomach and did not interfere with its capacity to hold solid food. People who are gastronomically educated act upon such knowledge, and take only a small quantity of clear soup or *consommé*, which is sufficiently thin to be soon absorbed, as a preparation of the stomach for a full meal to follow, or else, if they take a thick soup, they make a meal of that, at least in part. The hotel table, well provided, offers two soups, a thick and a thin one, and the diners choose as they please. The mistaken notion should not be entertained, however, that the thin soup is cheap; as it is made by the best cooks it is quite expensive, partly because it is a strong essence of meat, a sort of beef tea with all solid particles removed from it, and partly because of the large amount of white eggs wasted in clarifying it to that very transparent and brandy-like thinness which so many of our patrons condemn it for. And, again, when there is no particular need of adding to the number of dishes merely for style, one soup is sufficient, and that should be a thick one, as the hotel table will gain the more credit for it. But hotel providers often run to extremes in this line, also, and serve abominable mixtures as thick as porridge, messes that can be taken up on a knife point. That is not what is meant by thick soups so much as is having soups with something in them; neatly cut pieces of meat or vegetables, of clams and potatoes, of fried crusts or sippets; not porridge, but soups with morsels to be found

with the spoon and enjoyed because the appetite is then fresh and keen. That is the motive as well with clear soups, the *consommé* with green peas or asparagus tips. If the soup is worth serving at all, there should be at least a third of a plateful, if not half; let the people leave a little if they will, but the mere spoonful that just covers the plate, as served in some places, affords no satisfaction to anybody, not even to the cook, who knows that there is not enough in such a portion to allow his efforts at a skillful combination to be appreciated. But, of course, if your soup is bad the less you serve the better.

#### HOW MANY KINDS OF FISH?

Probably, in pursuance of a desire to please everybody, it would be best to have two kinds of fish, as a baked and a boiled; a fish in fillets with tomato or Spanish sauce, and another whole with only the simple melted butter. Ordinarily, it must be allowed, one kind is enough, while yet there are fishing resorts and other places peculiarly situated where several dishes of fish have to be offered daily. When serving fish as only a part of the hotel regular dinner two-ounce portions are enough unless some person wishes to pass the middle or latter courses of the dinner by and requests a full order.

#### HOW MANY ENTREES?

While, very often, it is a difficult matter to find materials to make a given number of entrees or made dishes every day, and cooks are glad to run in very common and useless dishes merely to fill up the list, still at other times a number of small meats and remainders of poultry and game are left on hand that will make excellent dishes for this list, but could not be utilized otherwise, so that there are motives of economy as well as excellence of the table in favor of keeping up a medium sized list of entrees. Three or four entrees each day is about the right number.

## HOW MANY VEGETABLES?

If a profusion of dishes be excusable anywhere it should be in the line of vegetables, and every improvement in the methods of cooking them should be encouraged both from motives of economy and of health. And on general principles the consumption of vegetables should be encouraged, instead of meat, as tending to reduce the cost of living. A wide field for the exercise of the cook's art exists in the richness of our American vegetable products, and it has not been worked out as meat and pastry cooking have, but affords plenty of room for new methods to be introduced. There should be six or eight vegetables each day and different ways of cooking some of them introduced almost as often.

## HOW MANY KINDS OF PASTRY?

The extraordinary fondness of Americans for pie, so often remarked upon, is only apparent, not real. We like the pastry department just as well as any other nation of people does, and no better; the reason why pie appears so prominent is because we call those things pie, which the English and French call by other names, consequently we have ten times as many pies (so called) as they have. The English pie has always a top crust; the things which we call corn-starch pie, lemon pie, custard pie, and the like, they make the same way in a deep dish, with a thin bottom crust of paste, and call them puddings, or, if small, cheesecakes; and our open fruit pies they call tarts. There is an English cook book that contains recipes for making one thousand puddings, but a large proportion of them over here would be called pies; that is how it is we seem to be the only pie-eating nation. For mere good living one kind of pudding or pie is sufficient, but from motives of policy the hotel table should be provided with two kinds, perhaps three—that is, a pudding, a covered pie and an open pie—and as ornamental considerations have the more weight to-

wards the end of a dinner, when the appetite is not so obtrusive, it is as well to care a little for the contrasts in appearance of the pastry, and let a showy meringue shine along with a dark fruit pie and a red cranberry along with a white or yellow custard. The universal liking for ice creams, the ease of making them now with the improved freezers and universal supply of ice, and the many varieties of such creams and frozen compounds now generally known, have almost driven out the favorite sweets of years ago.

CONCLUSIONS AS TO THE AMERICAN  
DINNER BILL OF FARE.

Some bills of fare of the best American hotels which appear to be quite wrong in arrangement when compared with French models are quite right according to Italian fashions. Some that are quite wrong according to the Italians are right according to the French. Those that are right according to one or both of them are wrong again according to German, or Spanish, or English, or Russian or other fashions. The only way to be right is to adopt an American form of bill of fare and count all of them wrong in the degree that they depart from it. The conclusions to be drawn from the foregoing examples and comments are:

1. There is a good form of American bill of fare already in use in the great majority of our hotels, but better specimens of it can be had from any part of the United States than from New York City.

2. It is necessary to have a top heading to the bill, and it is correct and quite optional to use either Bill of Fare, Menu, Dinner, or *Table d'Hote*.

3. It is best, on account of the strangeness of strange people in most hotels, to have headings to the divisions of the bill of fare, and nearly all foreign menus, except French fashionable party cards, set the same example; yet, if the hotel does not receive many strangers, headings are not required for regular residents. There is no

need of running to the extreme of big black letter headings in one case nor to a confused jumble of dishes in the other.

4. American preferences favor the preliminary course of raw oysters in the season and clams as a substitute at other times, and most of the cold side dishes. The hot *hors d'œuvre* to be eaten after the soup is not an American favorite in that place and is not needed. It is found to be most convenient to place the oysters in a separate line preceding the soup and the cold *hors d'œuvres* or side dishes after the soup, instead of the superfluous hot mouthful or *bouchée*.

5. Good foreign sanction can be found for the above arrangement, and equally good authority in the French fashion for placing such side dishes as cucumbers, olives, celery, sliced tomatoes, etc., after the fish instead of after the soup, and some of the best American bills of fare show the preference of many hotel keepers for that arrangement, which is quite an optional matter and immaterial.

6. The serving of fancy forms of potatoes with fish should be adopted as a part of the American fashion.

7. The solid boiled and roasted meats, which the English put under the heading of "Joints," should be placed in the American bill of fare after the fish and before the entrees, because that is the order in which they are generally called for. If high foreign sanction is wanted it can be found in two out of the "three royal examples" given in a former article, where the roasts come first, and also is the teaching of the French gastronomers that the plain and substantial dishes should come first.

8. When game appears in its season it should be placed in the American bill under a separate "game" heading immediately after the roast meats and before the entrees.

9. The gratuitous *sorbet* or punch is an added luxury, but is in a general way detrimental to the hotel keepers' interests. If wanted in the bill it should be placed after

the roast meats in the *table d'hôte* arrangements of dishes, for if placed lower down it only becomes a preliminary to the pastry, seeing that most people take meats, entrees and vegetables all at one serving, and the punch should go with them or immediately after. This feature is never found in a fashionable English dinner. They have no use for punch anywhere but with turtle soup, unless, perhaps, instead of wine after dinner.

Making allowance for the slight variation caused by the insertion of "game," the annexed, one of *chef* Theodore Pierrot's Sunday bills, may be taken to show

#### A REPRESENTATIVE AMERICAN-PLAN

##### BILL OF FARE:

##### HOTEL EMERY.

##### DINNER.

Sunday, March 1st, 1885.

##### SOUP.

Bisque of Oysters      Consommé Royal

##### FISH.

Filet of Sole à l'Orly  
Parisienne Potatoes

Chow Chow

Olives.

##### BOILED.

Ham and Cabbage      Turkey, Oyster sauce

##### ROAST.

Ribs of Beef  
Young Turkey stuffed, Cranberry Jelly

##### ENTREES.

Sweetbreads braized aux petits Pois  
Deviled Crabs, Baltimore style  
Filet Mignon saute, sauce Madeira

##### CARDINAL PUNCH.

##### GAME.

Prairie Chicken en Salmi, sauce Mushrooms

##### SALADS.

Fresh Lettuce      Chicken Mayonnaise

##### VEGETABLES.

Mashed Potatoes      Boiled Potatoes  
Stewed Tomatoes      Green Peas      Stuffed Cabbage-  
Asparagus, Cream sauce

##### PASTRY.

Mince Pie      Peach Meringue Pie      Pumpkin Pie  
Queen Pudding, Wine Cream sauce  
Apple Dumplings, Family style  
Sago Pudding with Cream sauce

##### DESSERT.

Vanilla Ice Cream      Charlotte Russe  
Champagne Wine Jelly  
Assorted Fancy Cake  
Fruits      Cheese      Crackers  
Coffee

10. There should be two soups, but not of the same character; one should be clear, the other thick.

11. The dishes regularly in a bill of fare should be sufficient in number to give opportunities to use up small quantities of provisions and remnants of good things and to tax the ingenuity of the cooks, but beyond that there should be no lavishness.

12. Many of the additions to our food known as relishes are real luxuries, and should be named in the bill in a line by themselves without a heading.

#### LUNCH AND DINNER OR DINNER AND SUPPER?

This question comes up whenever any hotel assumes the rank of first-class, and is often a very perplexing one, for a few insist that they must dine at about six or seven in the evening or never, and if that hour is adopted a greater number are made uncomfortable by it, for to dine in the middle of the day is natural (according to our national habits); to dine at night is artificial, the habit of the few who retire late at night and rise late in the morning. When the artificialists have their way, and the dinner hour is in the evening, a new contention arises, for then there is a lunch at mid-day, or about one o'clock, which for the hotel keeper's interest ought to be a light and inexpensive meal, a cold repast, but then the plain-mannered people try their best to make their accustomed mid-day dinner out of it, and the hotel caterer is urged to have this thing and that, to the end that they may make a complete meal, and the result is apt to be that the hotel gives two expensive dinners every day instead of only one dinner and a light supper, and at last it settles down, in many places where the rates are high enough, to the setting out of four meals a day, or even five: breakfast, lunch, then dinner and supper, both nearly together at from five to seven o'clock, and, in the few places, to having both lunch and mid-day dinner and then late dinner and supper also. This is the state of the case as experience compels

it, and we have but little to do with people's motives, yet when it is left purely optional with the hotel proprietor there are some arguments in it worth thinking over. It is a positive fact that heavy dinners or suppers are very unhealthy for people who go to bed at ordinary hours; the hotel man whose guests and boarders adopt such habits will have a lot of cross and uncomfortable people at breakfast times who cannot enjoy anything and cannot possibly be pleased. Those who eat meat dinners at night should remain up and in activity until twelve at least, and then take a cracker or slice of bread before retiring. But there is a business class of merchants and bankers who have no time for a regular formal dinner in the middle of the day, and a plausible reason in the necessity of the case can be given for them, but in the interests of good health and cheerfulness if they are to indulge in the profusion of the hotel dinner they should dine as early as possible—from five to six. A majority (but by no means all) of the really first-class hotels serve dinner in the evening, and take pains to publish it in their bill of fare as being the higher fashion, yet those who know all about the business are apt to doubt whether the guests really fare as well as under the other style. It costs more to have dinner at night; it keeps the cooking operations going on all day; there is no "let up" to hotel work until dinner is over, consequently dinner at night means late work as well as early, and more hands are required for it. Three, if not four, soups are required each day, and the inducement is strong to make the soup that is left over from lunch serve also for the evening dinner with only a change of name, and the same with roast meats and ice cream. When the proprietor, manager or steward is determined that the evening dinner shall be all fresh cooked he is careful to see that no more is cooked for lunch than will be consumed at once. The conclusion is that the night dinner is not the best on general principles; where business considerations compel its adoption there is

nothing to be said, but where it is but a matter of choice, as in a great many resort hotels, the proprietor, manager or steward will find it best to lean towards the dinner in the middle of the day. In many cases all parties may be satisfied with the dinner hour at two, half past, or three o'clock, and only a light cold meat and hot bread supper afterwards.

#### HOW MUCH FOR LUNCH?

The hotel man, as already observed, will find himself pulling the other way from a great number of his guests who want to make a good square meal out of the one o'clock lunch, and as the waiters and cooks are disposed to be accommodating he may soon find that the lunch is bigger and costlier than the evening dinner if he does not act with firmness to keep it down, and with equal firmness to close the doors at the stated time, otherwise the lunch is the longest drawn out and least satisfactory of all meals; very few people can be satisfied with it in any case.

This is a very fair example of a lunch bill of fare. It is from a New York hotel. The number of dishes offered is sufficient. Duration, from one to two o'clock:

#### LUNCH.

FROM 1 TO 2.

#### SOUP.

Crème à la Duchesse

#### COLD MEATS.

Turkey Beef Tongue Roast Beef

#### HOT DISHES.

Salmi of Venison, Champignons  
Chicken Rissoles

#### SALADS.

Mayonnaise de Volaille Cold Slaw  
Beets Salad à la Russe Potato

#### RELISHES.

Horse Radish Gherkins White Onions  
Olives Chow-Chow

#### PASTRY AND PRESERVES.

Quince Roll, Lemon Sauce  
Green Gage Plums Cake

#### COFFEE TEA

Dinner from 5:30 to 8.

All Dishes ordered not on Bill of Fare will be charged à la Carte

TUESDAY, February 3, 1888.

Peculiar circumstances sometimes cause a deviation from general rules. The writer was once concerned in a place where the lunch was by four or five times a better meal than the evening dinner, both in the number of people and in the dishes served. It was a fine hotel at the end of a railroad which brought daily excursions at half past twelve, too early to have dinner in any first-class hotel, so, lunch it was called, and that being a pleasure resort, with a brass band playing, the lunches were immense, though the dinners were very modest affairs for only a few regulars.

#### WHAT SORT OF DISHES FOR LUNCH?

In the hotel cook books may be found sample lunch bills of fare which show how some hotels serve a number of breakfast dishes, such as hominy and milk, also baked beans, pigs' feet, codfish balls, and various odds and ends to make up a good-sized list. In a general way those dishes may be chosen which, although good, seem hardly good enough or elaborate enough for a dinner entree; the salmi of venison in the specimen bill of fare shown in a preceding article of this series is an example. There is nothing wrong about it, yet we can but think it was only sliced venison with thin mushroom sauce; one would rather have birds of some kind for a salmi for dinner. Then all the hot *hors d'œuvres*, which it is hard to find a place for in the dinner bill, are just right for lunch; the chicken rissoles of the above mentioned bill is an example in point. All sorts of salads come in place for lunch, and all sorts of cold ornamental dishes, galantines and cold raised pies or *pâtes*. Besides these, the same list to be found further on, of dishes suitable for supper, is equally applicable to the lunch bill of fare. This bill, like the dinner bill, is changed every day, and has to be either printed daily or written.

The next is an example of the small bill of fare selected for children dining separately in care of nurses, in a large resort hotel where at least three times as many

dishes were served in the great dining room an hour later for the adults.

A number of these bills will be found with lines and reading notices apparently superfluous for the object of these articles, especially the breakfast bills now to follow; they are given entire, however, to show the usages of good hotels in these respects, purely for information.

*HOTEL SAN MARCO,*

St. Augustine, Fla.

CHILDREN'S ORDINARY.

DINNER,

SUNDAY, . . . . APRIL 10, 1887.

SOUP.

Chicken Consommé

FISH.

Boiled bass

BOILED.

Mutton

ROAST.

Ribs of beef

ENTREES.

Pineapple fritters Macaroni, à l'Italienne

VEGETABLES.

Mashed potatoes Stewed tomatoes

Baked sweet potatoes

COLD.

Tongue Ham Roast Beef

Lobster Salad

PASTRY AND DESSERT.

Baked Indian pudding

Lime meringue pie Apple pie

Assorted cake Strawberry ice cream

Apple sauce

Crackers Nuts Raisins

COFFEE.

THE BREAKFAST BILL OF FARE.

The common custom is to print the breakfast and supper bills in advance, perhaps a thousand at a time, and endeavor to have every dish that is named each morning or else mark it off. Where the hotel keepers and stewards are progressive and the additional expense of printing is not an obstacle a newly corrected bill is printed for every meal and a smaller list is sufficient, there always being something fresh to expect. Comparatively few of those

who have had experience with the dinner bill and its daily changes have had much practice in changing the breakfast and supper lists, and many will find it hard to think of new dishes to change with, and for their convenience a list of suitable dishes is given in the pages following these example bills.

*PEABODY HOTEL.*

BREAKFAST.

Fruit in Season

Oat Meal Cracked Wheat Grits

FISH. Fried or Broiled Fresh Fish  
Boiled or Broiled Salt Mackerel

BROILED. Mutton Chops  
Sirloin Steak, Plain, with Onions, Tomato or  
Creole Sauce  
Ham Bacon Calves' Liver Tripe

FRIED. Veal Cutlets, Breaded Kidneys  
Ham Sirloin Steak, with Brown Gravy  
Calves' Liver, with Salt Pork Corned Beef Hash  
Hamburg Steak Mush Sausage

STEWED. Mutton Kidneys Tripe

EGGS. Fried Boiled Poached  
Shirred Scrambled  
Omelets, Plain, with Parsley, Cheese,  
Onions or Jelly

COLD. Roast Beef Roast Mutton  
Corned Beef Boiled Ham

POTATOES. French Fried Stewed in Cream  
Lyonnaise Boiled Saute

BREADS, ETC. French, Vienna, Cream  
Graham, Corn and Plain Bread  
French Rolls Graham Muffins Corn Muffins  
Toast Crackers  
Corn, Wheat and Buckwheat Griddle Cakes

SYRUP. Maple White Rock  
New Orleans Molasses

COFFEE CHOCOLATE TEA MILK

HOURS FOR MEALS.

Breakfast, 7-11. Dinner, 1-4. Supper, 6-9.

SUNDAY.

Breakfast, 7:30-11. Dinner, 1:30-4. Supper, 6-9.

CHILDREN AND NURSES.

Breakfast, 7. Dinner, 1. Supper, 6

The first is from a hotel that prints a new supper bill every evening, but has this, its breakfast bill, stationary. Any



hotel keeper or steward who may be in the act of choosing a form of bill for a new hotel or other beginning will find use for all the particulars of headings, hours for meals, notices and all such particulars which are much better shown than written about.

**BREAKFAST.**

**FRUIT.**

Wheat Flakes      Oat Meal      Wheaten Grits

**FISH.**

Salt Mackerel      Fish Balls  
Broiled or Fried Fresh Fish

**BROILED.**

Beefsteak      Ham      Lamb Chops  
Breakfast Bacon

**FRIED.**

Ham      Rasher of Bacon      Tripe  
Frankfort Sausage

Stewed or Fried Pigs' Feet      Stewed Kidneys  
Smoked Beef with Eggs or Cream

**EGGS.**

Boiled      Fried      Scrambled      Poached on Toast  
Omelets, plain, with Cheese, Parsley and Jelly

**COLD MEATS.**

**POTATOES.**

Baked      Hashed with Cream      French Fried

**BREAD, ETC.**

Corn Muffins      Graham Bread  
French Rolls      Toast      Plain Bread

Oolong and English Breakfast Tea  
Coffee      Chocolate      Cocoa

**HOURS FOR MEALS.**

Breakfast 7 to 9.      Dinner 1 to 3.      Supper 6 to 8.

**NURSES AND CHILDREN:**

Breakfast 7.      Dinner 12:30.      Supper 5:30.

An extra charge for dishes ordered not on the Bill of Fare.

The second of these bills is from a hotel that prints a new bill for every breakfast, making the changes on wheat flakes, cerealine, hominy grits, graham farina, cracked wheat mush, rolled avena, and all the names which the manufacturers and merchants invent for such farinaceous wares; that is for the first line, and all the others are similarly changed, especially the styles of potatoes and breads and the entrees.

**BREAKFAST.**

**FRUIT.**

Oat Meal and Grits with cream

Green, English, Breakfast and Japan Teas  
Coffee and Chocolate

**BROILED.**

Beefsteak, Plain, Tomato Sauce or Onions  
Veal Cutlets, Plain or Breaded  
Mutton Chops, Plain, Breaded or with Tomato Sauce  
Lamb Chops      Calf's Liver      Mutton Kidneys  
Ham      Tripe      Breakfast Bacon  
Pigs' Feet, Plain or in Batter

**COLD.**

Lamb Tongues      Roast Beef      Smoked Tongues  
Pressed Corn Beef

**FISH.**

Broiled or Fried Trout      Sheephead      Redfish  
Croaker      Redfish Courtbouillon  
Tenderloin of Trout, Sauce Tartar  
Salt Fish with Cream.

Codfish Balls      Salt Mackerel

**EGGS.**

As Ordered

Saratoga Chips,  
Lyonnaise Baked and Stewed Potatoes

Broiled, Raw, Stewed and Fried Oysters

Stewed Kidneys, Tripe and Corned Beef Hash  
Sausages

Fried Hominy      Boston Brown Bread  
Vienna and French Rolls      Egg Muffins  
Graham and Plain Bread      Dry and Milk Toast  
Buckwheat Cakes      Maple Syrup      Honey

**BREAKFAST WINES.**

SAUTERNES.		Pts.	Qts.	CLARETS.		Pts.	Qts.
Haute Sauterne...	\$1 00	\$2 00	St. Julien.....	\$0 75	\$1 25		
La Tour Blanche...	2 00	....	Chatcau Bouillac...	75	1 25		
Sauterne.....	1 00	2 00	St. Estephe.....	75	1 25		

Breakfast from 6 to 9:30      Dinner from 1 to 3  
Supper, 6 to 9.

Breakfast on Sunday, 8:00 to 10:30  
Dinner      "      "      2:00 to 4:00  
Supper      "      "      6:30 to 9:00

Dishes ordered not on this Bill will be charged extra.

The third breakfast bill shows another style. It is the winter breakfast bill of a large New Orleans hotel, one of the best in the South, printed a thousand at a time and showing a rich variety, but yet has two blank lines left to write in any novelty or fresh acquisition from the markets. The list of breakfast wines accords with the customs in that part of the country.

*"THE SAN MARCO."*

BREAKFAST.

Oranges

Tea Coffee Chocolate Shells Hominy

Oatmeal mush Hot rolls Dry and Cream toast

FISH.

Broiled shad Smoked herring  
Smoked salmon Codfish balls Codfish and cream

Codfish hash Fried oysters  
Stewed oysters Broiled salt mackerel

BROILED AND FRIED.

Sirloin steak Bacon Mutton chops Veal cutlets  
Venison steak Pickled tripe  
Liver Sausages Ham  
Pickled pig's feet

Mutton chops, breaded, tomato sauce  
Stewed tripe Stewed chicken  
Veal cutlets, breaded, tomato sauce  
Corned beef hash Fried hominy  
Fried Indian meal mush  
Stewed kidneys Fried bananas

EGGS.

Boiled Fried Scrambled Poached Omelettes

POTATOES.

Baked French fried Saratoga Lyonnaise  
Hashed browned Hashed, with cream  
Baked and fried sweet

Gridle cakes Buckwheat cakes  
Maple Syrup

The fourth is the breakfast bill of one of the finest winter resort hotels in Florida, under northern management. This is a stock bill of fare, printed a thousand at a time, but has a style of its own and is devoid of notices or any extraneous additions.

*THE SHERWOOD.*

BREAKFAST.

TOMATOES

BAKED APPLES FRUITS STEWED PRUNES  
OATMEAL HOMINY CRACKED WHEAT

BREAD, CAKES, ETC.

French Rolls Graham Rolls English Muffins  
Boston Brown Bread Corn Bread  
Rye Bread Rice Cakes Wheat Muffins  
Rice Muffins Indian Cakes Crumpets  
Wheat Cakes

FISH.

Salt Codfish with cream Fish Balls  
Baltimore Roe Herring Salt Mackerel  
Codfish Hash Smoked Salmon Smelts  
Shad Codfish steak

BROILED.

Beefsteak Ham Pig's Feet broiled  
Mutton Chops Veal Cutlets Breakfast Bacon  
Mutton Kidneys Calf's Liver and Bacon  
Chicken Pork Chops  
Chicken Livers en brochette

STEWED.

Mutton kidneys with mushrooms  
Chicken Livers with mushrooms  
Clams Oysters Roast Beef Hash Chicken Hash  
Corned Beef Hash

FRIED.

Hominy Mush Deerfoot Farm Sausages  
Oysters Scollops

EGGS.

Boiled Scrambled Poached Fried  
Shirred Omelet

POTATOES.

Baked Hashed with cream Fried  
Lyonnaise Sautees

Breakfast, 7 to 11. Lunch, 1 to 2.  
Dinner, 6 to 7:30. Supper, 9 to 11:30.

The fifth, a New York City hotel bill, with a list as rich and abundant as any, shows different ways of grouping the articles together and is suggestive of many suitable breakfast dishes. Nothing could show so well as this bill how much work must be done in a hotel before breakfast. Undoubtedly there are too many dishes offered in all but one or two of these bills, still, as a good many of them are not cooked until ordered the destruction of provisions is not quite as serious as it looks.

Manifestly the proper rule in composing the breakfast bill is to place the dishes in the order that they are eaten by the generality of people. It is the custom, and

the fashion, too, to eat fruit as a beginning, and then oatmeal or hominy or cracked wheat with cream; only small portions are served. After that the fish, meats, eggs and potatoes and bread are selected from all at once, and it makes little difference except for the appearance of the bill what order they are printed in, but waffles, crumpets, and all kinds of griddle cakes are eaten last and should appear last in the bill, as they do in most of the examples. The San Marco bill is the best model as regards the arrangement of different classes of dishes.

#### ABOUT THE AMERICAN BREAKFAST.

There is no French pattern for the American breakfast bill; the French do not know anything about any such breakfasts as our hotels set out. The English have some idea of it, for they believe in taking a tolerably substantial meal to begin the day upon, but their ideas of what something substantial consists of do not reach up anywhere near the displays of actual meals in the five breakfast bills of the foregoing pages. The French custom is to take a light breakfast of coffee or chocolate and rolls or bread, and defer the eating of a hearty meal until the middle of the day; the English expect for breakfast, besides the coffee or tea, a chop, or bacon and eggs, hot rolls from the bakers, and butter, or toast with some sort of appetizing addition such as potted tongue, anchovies or marmalade, and that is thought to be a sufficiently plentiful meal to last until lunch at noon; dinner taking place at two or three o'clock and a cold supper some time between candle-lighting and bed-time, according to the habits of the family, and the same form prevails in the hotels.

Without leaving our proper domain and going into that of the doctor's it may at least be asserted that our people eat too much for good health and at the wrong times. Could anybody reasonably contend that such an immense number and variety of viands are necessary as appear on the third, fourth and fifth breakfast bills pre-

ceeding? And yet a necessity of a certain kind does exist, it is the business necessity which obliges the hotel keepers to try to please people who, having eaten too much the day and night before, have no real healthy appetite for breakfast, but pick around, find fault, and imagine that if there was only something else which is not there they could eat; that oysters stewed and fried are perhaps very good, but as for them they can never eat them any way but broiled, and while the friend at their right must have fresh fish, yet criticises the shad for its bones—for their part if all the fishes of the sea were there they can only pick a bit of smoked salmon. While such an unreasonable demand for quantity exists the demand will be supplied.

"My dear Careme," once said the Prince Regent to his famous *chef*, "your dinner yesterday was superb. Everything you gave me was delicious, but you will make me die of indigestion."

"Mon Prince," returned Careme, bowing low, "my duty is to flatter your appetite, not to control it."

There is no doubt, however, that it is frequently the case in our hotels that the hotel man, the proprietor, manager or steward, as the case may be, has it quite within his own control to provide a small but excellent spread instead of such an overgrown catalogue as those shown. It is sometimes ill-naturedly charged that these bills of fare are not true representations of the actual meals, that a large portion of the dishes are "crossed off" before the bill goes to table. In fact, there is nothing more distasteful to the hotel keeper or steward than to have a "scratched" bill go to the table, and great trouble is often taken and considerable expense to obtain some scarce article, not so much because it is really needed as because it is on the bill of fare. So where it is optional, or nearly so, with the hotel man whether he will make out a big list of dishes or a small one he should limit the number to a reasonable amount, and limit the styles of cooking, too; for the more ways of cook-

ing allowed the more utensils, more hands (or more haste), the more previous preparation and more waste. Whatever else may be said of the hotel breakfast, it is, unless under very good management, the most wasteful meal of all, chiefly through the propensity of the guests to order and leave things which they have not the appetite to eat, and in a great measure through the number of things offered necessitating the preparation of so many steaks, chops, potatoes, breads, fruits, pieces of fish and the whole list according, which, if not used, are the more liable to be lost through being so prepared.

A SMALL PATTERN, BUT SUFFICIENT.

Rather than be compelled to include almost everything in a stock bill of fare, and to cross off several dishes each morning because unattainable, it is better to name too few; have the bill printed with a blank line or two, and write in something special every morning. It may be chicken or oysters, perhaps, in some places, but if only one kind of hash (the New York breakfast bill has three) it will be better thought of for being special that day than many of the stock dishes already printed in. This example shows the form:

<i>BREAKFAST.</i>			
FRUIT			
COFFEE	TEA	HOMINY	OATMEAL
FISH.			
SALT FISH AND CREAM		FRESH FISH	
BROILED MACKEREL		CODFISH BALLS	
BROILED AND FRIED.			
SIRLOIN STEAK		LAMB CHOPS	
BREAKFAST BACON		BROILED HAM	
FRIED SALT PORK		BROILED TRIPE	
-----			
EGGS.			
BROILED	FRIED	SCRAMBLED	OMELETTES
COLD.			
HAM		TONGUE	BEEF
POTATOES.			
BAKED		LYONNAISE	FRIED
FRENCH ROLLS		HOT CORN BREAD	
DRY TOAST, MILK TOAST, BUTTERED TOAST.			

As a commentary upon the absurd profuseness of the American hotel breakfast these bills of fare, from one of the Peninsular and Oriental Royal Mail steamships, are appended. It is true they do not enumerate the breads, coffee and vegetables, but neither do they offer many varieties of meats or fish, or of porridge, or miscellaneous ways of cooking.

*BILLS OF FARE.*

P. & O. ss. "Thames" (at sea between Gibraltar and Plymouth.)

**BREAKFAST.**

Porridge  
Fried Fish  
Mutton Chops  
Minced Collops  
Grilled Bacon  
Scrambled Eggs  
Curry and Rice  
Cold Ham

**LUNCHEON**

Soused Herrings à la Sardine  
Corned Brisket, Roast Mutton  
Bologna Sausages, Galantine of Veal  
Salad  
Mashed Potatoes, Cheese, Buns

**DINNER.**

SOUP—Green Pea  
FISH—Salmon Cutlets à la Maitre d'Hotel  
JOINT—Roast Beef and Horse-radish Sauce  
ENTREES—Rissoles of Pheasant à la Pompadour  
Macaroni à l'Italienne  
POULTRY—Roast Capon and Ham  
CURRY—Mutton  
PASTRY—Lemon Jelly  
Almond Custard  
Plum Pudding

Therein may be found, likewise, good sanction for a class of "breakfast entrees," such as our sample bills show; there are minced collops, and curry and rice. Also, an idea for making curry a standing dish with a permanent heading, the kind of meat to be changed at will, for dinner.

A SPECIAL BILL WHICH IS LARGE ENOUGH  
FOR ALL TIMES.

*PEABODY HOTEL.*

BREAKFAST.

SUNDAY, MAY 16, 1886.

Strawberries with Cream

Oat Meal      Cracked Wheat      Grits

BROILED—

Spanish Mackerel, Maitre d'Hotel Sauce  
Duchesse Potatoes

Spring Chicken, Water Cress  
French Fried Potatoes

EGGS—      Fried      Omelets      Boiled  
         Shirred      Poached

BREAD, ETC.—

French Rolls      Graham Muffins  
Corn Muffins      Brioches  
Wheat Cakes      Corn Cakes

Coffee      Chocolate      Tea

THE AMERICAN SUPPER OR TEA.

The same thing that has been done for the breakfast could not be done for the supper; that is, the presenting of a set of bills that fit alike all hotels in any part of the country, for while there is great uniformity of practice in one respect there is extreme diversity in the other. The American breakfast is always a substantial meal; the supper may be anything to suit the place, or may not appear at all. The general American habit is to partake of only three meals a day: a good breakfast, a good dinner, a light supper. In many hotels, such as those in country towns and at resorts, houses that are not too fashionable—that is to say, not too city-like—these healthful habits can be kept up; the hotel keeper provides a very plentiful dinner, all his assistants work hard for it, and after that all is quiet; the third meal of the day is easy. In the middle, southern and western states it is called supper; in the northern section and in Canada it is called tea. In a great many hotels which make light

of this meal the bill of fare is headed "Tea Card," and the guests are not encouraged to expect much from it. Before the railroads had spread all over the country it used to be a saying "the pastry cook makes the supper," which meant that hot-breads, cakes and toast and, perhaps, baked potatoes were all that would be especially cooked; cold meats, stewed fruit, coffee, tea and milk serving to complete the meal. Hotel proprietors used to be divided in two classes: those who gave hot beefsteak for supper and those who did not, and there was a subdivision of those who gave hot beefsteak every night except Sunday and those who gave it every night in the year, Sunday making no difference. The only other hot dish allowed in the beefsteak houses was boiled salt mackerel. But there was great choice of breads, rolls, rusks, coffee cakes, coiled buns, corn-bread, muffins, ginger-bread, buttermilk, biscuits, beaten biscuits, waffles, batter cakes, toast and cold bread of several varieties.

One reason why the hotel supper has changed from the old simple style is found in the arrival of railroad trains at supper time; the travelers coming to the hotel must have a good meal, and the supper bill is almost equal to the breakfast bill shown a little way back. The broiled steak and boiled mackerel are found there as of old, but in addition there are chops and cutlets, fried fresh fish, spare-ribs, eggs, oysters, chicken—more things than we care to enumerate. Another cause is the desire of a few in almost every town to dine at supper time instead of mid-day, when the hotel keeper, not caring to change his hours to please a few, sets out a supper bounteous enough to allow them to call it dinner if they please. The annexed example is the very moderate bill of fare of a very large hotel which is in exactly the above described position, the regular dinner being served at from one to three and no dinner in the evening, unless special for a party. This is, as far as it goes, an excellent pattern, the better because it allows so few varieties of hot meats.

*SUPPER.*

Vienna Coffee ————— Chocolate  
 Japan and Gunpowder Tea  
 Sweet Milk

French Rolls ————— Johnny Cake  
 Saratoga Rolls  
 Graham, Rye and Wheat Bread

Broiled Sirloin Steak  
 Fried Black Fish

Eggs—Boiled, Fried, Shirred, Scrambled  
 Omelettes Plain, with Parsley, Onions  
 Tomatoes or Ham

French Fried Potatoes  
 Saratoga Chips ————— Baked Irish Potatoes  
 Pearl Grits

Cold Roast Beef ————— Cold Roast Mutton  
 Cold Corned Beef ————— Cold Smoked Tongue  
 Cold Boiled Ham

Beet and Cabbage Salad ————— Potato Salad

Assorted Small Cakes  
 Frozen Tapioca Custard

Articles taken or sent from the table, and dishes ordered not on this Bill of Fare, will positively be charged for extra.

## RISING EQUAL TO THE EMERGENCY.

For a hotel in a large and growing city, where bankers and merchants who would like dinner to be in the evening if it were convenient, are numerous among the guests, and where the trains bring many passengers; also at those resorts where many people of fashion contend in favor of the late dinner, the happiest combination of a supper with some dinner dishes added is this in practice at the hotel named below. It is the conception of the accomplished steward of that house, Mr. George Fulwell, who is a specialist in bills of fare, taking as much pleasure in the development of ideas in that particular line as some men do in producing a new variety of fruit and others do in carrying off the honors at the exhibitions; but he has paid attention to this branch and knows how to put his practical knowledge of the steward's business to account in suiting the tastes and convenience of all the patrons of the hotel alike.

*PEABODY HOTEL,*

MEMPHIS, TENN.

*SUPPER.*

Cerealine Porridge

ENTREES—Broiled Veal Chops  
 Stewed Turkey Giblets, with Peas  
 Ragout of Mutton, with Tomatoes  
 Blanquette of Rabbit, Milanaise  
 Fried Codfish Balls

COLD—Roast Beef ————— Roast Duck  
 Venison Salad

EGGS—Shirred ————— Boiled ————— Scrambled  
 Omelets, with fine herbs

POTATOES—Baked ————— Saratoga Chips  
 German Fried

BREAD, ETC.—French Cream Graham Plain  
 Vienna Rolls Tea Biscuits Toast  
 Rye Griddle Cakes

SYRUPS—Maple ————— White Rock  
 New Orleans Molasses  
 Coffee ————— Tea ————— Milk  
 Preserved Cranberries and Assorted Cakes

## HOURS FOR MEALS.

Breakfast, 7-11. Dinner, 1-4. Supper, 6-9.  
 SUNDAY.  
 Breakfast, 7.30-11. Dinner, 1.30-4. Supper, 6-9.  
 CHILDREN AND NURSES.  
 Breakfast, 7. Dinner, 1. Supper, 6.

Tuesday, January 3, 1888.

*SUPPER.*

Oat Meal Porridge

OYSTERS—Stewed ————— Fried

ENTREES—Broiled Pig's Feet  
 Fried Veal Cutlets, Robert Sauce  
 Stewed Kidneys, Madeira Sauce  
 Braised Beef, with Mushroom

COLD—Venison ————— Pork  
 Mutton ————— Salmon Salad

POTATOES—Baked ————— Hollandaise  
 Saratoga Chips

BREAD, ETC.—French Graham Cream Plain  
 Finger Rolls ————— Currant Coiled Buns  
 Toast ————— Flannel Griddle Cakes

SYRUPS—Maple ————— White Rock  
 New Orleans Molasses  
 Coffee ————— Tea ————— Milk  
 Canned California Cherries and Assorted Cakes

Wednesday, January 4, 1888.

Two of these bills of succeeding dates are printed to show where the changes come in. It will be observed that this is far in advance of the regular stock bill of fare, in being a fresh composition printed daily and changed in nearly every particular, yet without depriving the guests of their accustomed favorite dishes; the hotel does not abandon the mid-day dinner which the greater number of people like best, but changes the make-up of the supper without adding to the number of dishes so that they can dine at night who wish to do so. There is no beefsteak, therefore fewer loins of beef to cut up; and no soup to be re-christened from a mid-day lunch, but there are eggs one evening and oysters the next; the potatoes, breads, cold meats and supper fruit are all changed about, just enough to give freshness and variety without depriving any person of the regular diet of rolls, baked potatoes or batter cakes. In those hotels where the dinner hour is changed to evening the greatest discontent is occasioned by the disappearance from the menu of hot rolls and biscuits, fried potatoes and batter cakes, and, be the dinner never so plentiful, nothing that can be offered can quite make up the loss to those who have been in the habit of eating and enjoying those popular articles of diet for supper all their life. The new form of bill under consideration appears to be a compromise for all parties. A compromise used to be thought a good thing in the time of the great Henry Clay, and a compromise at one time was thought to be all that was needed to avert the war of secession; this compromise bill of Mr. Fulwell's by a parity of reasoning ought certainly to be effective in keeping the peace between the early and late dinner factions, even in a growing commercial city like Memphis. "Back numbers" of these bills (for the system has been in satisfactory operation for several months) show variations in the plan of this expert, whose efforts to rise above the commonplace are worthy of re-cognition especially in this land where gastronomical education is at present at a low stage and teachers are few. One sample more is inserted here with very good will towards the author:

SUPPER.

Tuesday, September 6, 1887.

Rolled Oats Porridge

OYSTERS—Fried \_\_\_\_\_ Stewed \_\_\_\_\_

BROILED—  
Pig's Feet \_\_\_\_\_ Liver, with Breakfast Bacon \_\_\_\_\_

FRIED—Croquettes of Veal, French Peas \_\_\_\_\_

MISCELLANEOUS—  
Braised Beef, with Vegetables \_\_\_\_\_  
Boiled Salt Mackerel \_\_\_\_\_ Welsh Rare-Bit \_\_\_\_\_

COLD—Roast Beef \_\_\_\_\_ Roast Veal \_\_\_\_\_ Chipped Beef \_\_\_\_\_  
Roast Chicken \_\_\_\_\_ Corned Beef \_\_\_\_\_  
Italian Salad \_\_\_\_\_ Sardines in Mustard \_\_\_\_\_

POTATOES—Baked \_\_\_\_\_ Saratoga Chips \_\_\_\_\_ Provencale \_\_\_\_\_

BREAD, ETC.—French, Graham, Vienna, Cream and Plain Bread \_\_\_\_\_  
Vienna Saltz Kipfel Rolls \_\_\_\_\_ Cream Scones \_\_\_\_\_  
Toast \_\_\_\_\_ Flemish Gridle Cakes \_\_\_\_\_

SYRUPS—Maple \_\_\_\_\_ White Rock \_\_\_\_\_  
New Orleans \_\_\_\_\_ Molasses \_\_\_\_\_  
Coffee \_\_\_\_\_ Chocalate \_\_\_\_\_ Tea \_\_\_\_\_ Milk \_\_\_\_\_  
French Prunes and Assorted Cakes \_\_\_\_\_

PORRIDGE DISHES AVAILABLE FOR SUPPER  
AND BREAKFAST.

Cornmeal Mush.  
Shredded Maize Porridge.  
Rolled Oat Porridge.  
Cracked Wheat Porridge.  
Rolled Avena Porridge.  
Cracked Wheat with Cream.  
Cerealine Porridge.  
Farina Mush and Milk.  
Home-made Hominy.  
Wheaten Grits.  
Pearl Grits.  
Stewed Wheat.  
Steamed Rice.  
Apple Tapioca and Cream.  
Cracked Wheat with Milk.  
Oatmeal with Milk.  
Oatmeal Porridge.  
Mush with Milk.  
Graham Mush.  
Oatmeal with Cream.  
Graham Farina Porridge.  
Hominy Grits and Cream.  
Rice Grits and Milk.  
Wheat Flakes with Cream.  
Large Hominy and Milk.  
English Furmety.  
Cream Sago.  
Manioca Porridge.

[A condensed description of the composition of every dish in these lists, which is not sufficiently apparent by its name, will be found in the Dictionary of Dishes, soon to follow.]

FISH ENTREES AVAILABLE FOR SUPPER  
AND BREAKFAST.

Broiled and Fried Fish of all Kinds.  
Cutlets of Black Bass, Genoise Sauce.  
Salmon Steak, Sicilian Sauce.  
Fillets of Whitefish, Remoulade Sauce.  
Fondue of Fish.  
Scalloped Fish.  
Panned Perch with Bacon.  
Canned Salmon.  
Smoked Bluefish, Boiled.  
Spanish Mackerel, à la Maitre d'Hôtel.  
Codfish Balls.  
Codfish Cakes.  
Picked-up Fish in Cream.  
Mackerel in Tomato Sauce.  
Sardines in Mustard.  
Sardines, Truffles.  
Barbecued Redfish.  
Baltimore Roe Herring.  
Salt Codfish in Cream.  
Codfish Steak.  
Codfish Hash.  
Broiled Salt Mackerel.  
Redfish Courtbouillon.  
Oregon Salmon.  
Mullet Roes, Fried.  
Smoked Salmon.  
Smoked Halibut.  
Smoked Haddock.  
Boiled Salt Mackerel.  
Smoked Herring.  
Trout Courtbouillon.  
Salmon with Parsley and Butter.  
Fillets of Soles, à la Maitre d'Hôtel.  
Baked Mullet, Fine Herbs.  
Baked Whitefish.  
Broiled Florida Trout.  
Broiled Pompano.  
Codfish Tongues on Toast.  
Fresh Shrimps.  
Potted Shrimps.  
Buttered Shrimps.  
Curried Shrimps.  
Curried Lobster.  
Anchovy Cakes.  
Shrimp Omelette.  
Potted Lobster on Toast.  
Sardines and Watercress.  
Scalloped Codfish.  
Smoked Finnan Haddock.  
Fried Slices of Cod.  
Anchovy Toast.  
Hot Boiled Crab.  
Sardines on Toast.  
Shrimp Pie.  
Shrimp Patties.  
Broiled English Bloaters.  
Curried Oysters.  
Fish Quenelles.  
Fish Croquettes.  
Lobster Cutlets.  
Fresh Fish in Cream.  
Fish Flakes, à la Bechamel.

Boiled Codfish Palates.  
Curried Sardines.  
Bloaters in Batter.  
Shrimps and Boiled Rice.  
Scalloped Lobster.  
Fresh Herrings Stuffed.  
Broiled Kippered Salmon.  
Salmon and Macaroni.  
Stewed Mackerel.  
Lobster Rissoles.  
Herring Roe and Mushrooms.  
Lobster Creams.  
Dressed Crab.  
Anchovy Toast with Egg.  
Sardines en Caisse.  
Lobster à la Crème.  
Canapes of Sardines.  
Scalloped Shrimps.  
Sardine Sandwiches.  
Shrimp Canapes.

[Other fish dishes with description of all can be found in the *Dictionary of Dishes* further on.]

OYSTER ENTREES AVAILABLE FOR SUPPER  
AND BREAKFAST.

Fried Oysters.  
Stewed Oysters.  
Oysters with Macaroni.  
Oysters in Small Loaves.  
Oyster Toast.  
Steamed Oysters.  
Oyster Patties.  
Vol au Vents of Oysters.  
Oysters in Croustades.  
Scalloped Oysters.  
Oysters à l'Indienne.  
Oyster Kromeskie.  
Oysters à la Brochette.  
Oyster Omelets.  
Oysters en Caisse.  
Broiled Oysters.  
Oyster Rissoles.  
Oyster, Fritters.  
Oysters in Wafer Shells.  
Oysters Broiled in Bacon.  
Oyster Chowder.  
Oysters Fried in Batter.

Clams in same ways as oysters.  
Scallops in same ways as oysters.

EGG ENTREES AVAILABLE FOR SUPPER  
AND BREAKFAST.

Eggs in about one hundred ways are available, for which see the dictionary of dishes further on.

It is unnecessary to follow further with such lists, as all the forms of meat entrees and ways of cooking potatoes are already familiar to those who prepare the dinner bills of fare. The foregoing lists are intended to help those who have to make new breakfast and supper bills daily, which is comparatively new business.



# THE STEWARD'S HANDBOOK.

PART SECOND.

---

## RESTAURANT STEWARDING

COMPRISING A SURVEY OF VARIOUS STYLES OF

Restaurants and their Methods,

CLUB STEWARDING AND CATERING,

PUBLIC PARTY CATERING, BALL SUPPERS,

BASE BALL LUNCHEES, HOTEL BANQUETS, ETC.

HOW TO PREPARE AND HOW TO SERVE THEM: WITH NUMEROUS  
PATTERN BILLS OF FARE CARRIED OUT TO  
QUANTITIES, COST AND PRICE  
PER HEAD.

---

BY

JESSUP WHITEHEAD.

---

CHICAGO.

1889.



# RESTAURANT STEWARDING.

---

“The difference between hotel and restaurant, did you ask? Oh, everybody knows that. The difference is—well, let’s see—the difference is, at a restaurant you can get your meals any time you want, and in a hotel you can’t, because they close their doors. The restaurant man is glad to see you come in at any hour of the day or night, while in the hotels they look at a fellow like he had felonious intentions if he tries to get in to eat after their time is up.”

Good enough as far as it goes, but if we think it over a little we shall find greater differences than that.

Hotel-keeping is good housekeeping on a magnificent scale; restaurant-keeping is merchandizing in meat and drink. The hotel Boniface keeps a good house; the restaurateur has command of the markets. The hotel-keeper takes care of people; the restaurateur attends upon people who try to take care of themselves. The hotel-keeper provides a home for a number subject to rules; the restaurateur provides a refuge for those who know no rules or are ruled out. The hotel-keeper thinks the most of his customers in the aggregate and will not change his ways to suit different individuals; the restaurateur thinks most of the individuals and is not disturbed if their tastes differ to wide extremes. The hotel-keeper provides meals for numbers by wholesale methods, such as would cost the individual three or four times as much to provide singly for himself; the restaurateur provides by retail methods the separate meals as ordered and charges for his services. The hotel-keeper thinks and manages for all; the restaurateur invites each one to think and manage for himself and adapts his establishment to meet every caprice.

The model restaurant keeper stocks up like a merchant with everything that will sell; secures the latest novelties like a merchant; displays his goods like a mer-

chant; advertises like a merchant; makes his prices according to the demand; makes his money out of the luxuries rather than the necessities of his customers.

When the hotel steward goes to market and finds some desirable thing, the question with him is “Will it pay?” The restaurant steward asks himself, “Will it sell?” The first must limit his purchases within the bounds of the price per day charged by his house; the other must judge whether any among the known or probable patrons of his restaurant will buy the fresh delicacy at the price demanded. The hotel bill of fare shows how much can be done for a certain fixed price per head; the restaurant *carte* shows what there is in market, and, consequently, in the restaurant larder, and what it will cost if ordered.

---

The hotel steward hiring hands expects to have but one set for the day; only one continuous watch. He hires them for long days, not comparable with the days of other classes of workers, if counted in hours, yet broken up and made easy by intervals between meals. He has times to close his doors and give most or all of the hands a recess. The restaurant steward hires them for so many hours continuous work without breaks or intervals; and when the clock strikes the watch on duty stops work and the next watch takes hold as promptly as in a factory; he strives, therefore, to apportion the workers to the duties to be performed in such a way that their time will be fully employed during all the hours he pays them for. He rarely closes his doors at all. The restaurant meals are never over, but always beginning. The most unseasonable hours are often the best for business. When the hotel is asleep and the theatre is over the restaurant is most awake, and the fresh hands newly come on watch then render their best work in cooking and service.

The restaurant exists for odd times, unseasonable hours; to be outside of common rules and habits; to meet sudden emergencies, unusual demands, transitory fancies and passing fashions. The successful restaurateur is like a courtier, making each customer in turn think he is the only one that really knows how to order a dinner, or has a true appreciation of what is good and *en regle*. The successful steward is one who can carry a stock so varied, even of perishables, that he can never be taken unawares by the most unexpected orders, and who yet loses the least through the spoiling of provisions.

The best cooks, probably, are hotel cooks who have had a previous restaurant training. Hotel cooks attain their greatest excellence in that most valuable knowledge of cookery which the French common people are credited with possessing as a birthright, which Alexis Soyer gave such a brilliant example of when he showed the British soldiers in the Crimea how to take the rations which they were starving and dying upon and make them into palatable and nutritious soups and stews, such as their French neighbors and allies were concocting so well from the same poor supplies. Hotel cooks learn good management; they learn the economies; to make much of little; to suit the average greatest number; but the restaurant cooks are the more ornamental in their work; they must learn styles and fancy touches and take instructions from many critical or whimsical customers. The individual style service of hotel dinners in small dishes has a certain prettiness of its own and a proprietary exclusiveness about it which delights many, but the restaurant entire dishes for parties of four, six or eight give the cooks room and opportunities for styles of decoration which untraveled hotel cooks have no inkling of. A restaurant cook having to serve even so common an order as sausage and mashed potatoes for two, price a few cents, will place four separate, smooth spoonfuls of potato cross-fashion in the

dish, a brown fried sausage pressed halfway in the top of each and gravy over all, and sends in an attractive dish with a shape to it, when in inexperienced hands it would be nothing, but potato in one dish, sausage in another, common and unnoticeable; alike in the commonest boarding house and the best hotel. From such simples the restaurant cook's work rises to whole dishes of fish, fowl and game, with foreign names, styles and ornamental accessories. At the same time the restaurant cook has an expensive liking for large portions, choice cuts, whole steaks, whole fishes, plentiful wines to stew in and the free use of imported rarities encouraged by a class of customers who pay a dollar or several dollars for a single dish, but which he must modify to some extent in the hotel according to its style and prices.

The hotel headwaiter having a party or a family whom he desires to have particularly well served, after locating them at the pleasantest table, looks around among his waiters for one who has experience in a restaurant. The restaurant waiter may seem slow and inefficient amongst a crowd, but he is the one they want when minute personal attentions are required; the one who never forgets; is never in a hurry to get away; neither hears nor sees anything at his table except his own duties. Restaurant training makes that sort of waiter.

But as everybody knows, they are not all restaurants that are called by that name. The real restaurants of the original Parisian sort are very few. Some, even of the most famous of modern French establishments have closed up within the last few years. Some writers account for the decrease by saying the rising generation is becoming more mercenary and prefers the *table d'hote* with its fixed price for dinner or supper to the gilt-edged restaurant with its fancy prices and the latter falls into decline through the growth of economical tendencies. However, the original pattern of restaurant will still exist,

few but remarkable, and there are modifications of it growing everywhere in increasing numbers.

#### THE RISE OF THE RESTAURANT.

The rise of the restaurant is nearly always alike—semi-accidental. It might seem a curious line of argument to pursue, but it is more than likely it could be proven that of those who “open a restaurant” nineteen out of twenty fail. There seems to be a special adaptation to the business required, a love of it, and a kind of talent not often to be had for money. The first great Parisian restaurants, which attracted world-wide notice and imitators in all countries have been mentioned so often—Beauvilliers’—Very’s—Robert’s—that one is loth to touch again upon a subject so old, yet all the mention is of them in their prime, in their success; nobody knows how they began, nor by what accident of patronage their originators were started. Here is a modern, a very recent instance, which is an illustration that will suit nearly every case and shows that restaurateurs are “born, not made.” It is of one Joseph—he has another name, but as Joseph only he is noted in the papers—who had a small restaurant somewhere in Paris, “Joseph’s restaurant,” and became the favorite of an appreciative few. He had some specialties, some special ways of pleasing his patrons which we may not know—they were his special points of adaptation which made him successful and, perhaps, were generally of too small dimensions to be described, they were characteristics. But one point was of sufficient saliency to be taken hold of; something he did which became the talk of gastronomical Paris. What was it? What could one obscure man in a small restaurant do that made all the gilded and glittering establishments of old standing envious? He served as nobody else could, *Canard Sauvage, Sauce au Sang*—Wild Duck with Blood Sauce—roast wild duck with its natural gravy. It is hard to avoid writing cynically about such a matter, but we will try. Some of these things which

catch the passing fashion are so exceeding small, the admiration of them seems asinine; yet somebody must uphold and magnify them—the restaurateur must. To tell how it was done is but a parody on another old story of how some wondrous cook electrified a court and charmed all christendom by the genius shown in cooking two beefsteaks and squeezing the gravy out of one to pour over the other which was for the prince. M. Joseph roasted his ducks very rare, then cut the breasts in slices upon a chafing dish (a metal dish with an alcohol lamp under, to keep it at cooking heat), the gravy from the rare-cooked slices flowing freely. All the rest of the carcass he squeezed dry to obtain the juice for the slices of breast of duck, and he let all finish cooking in the dish, the gravy of course thickening itself, and served the meat so in its own juices. It may be he added flavorings and seasonings, the reporters do not say, and if so they were but incidental. *Canard Sauvage, Sauce au Sang* was the dish. And let the host of carvers of “Roast Beef Rare” at the merchants’ lunch houses, chop houses, restaurants, dining rooms, cafés and hotels remember it when they see the “natural gravy” flow into the dish of the hot carving table and cook and become thick there—that is the *sauce au sang*, the blood gravy which, when drawn from wild ducks, a large number of Parisian *gourmets* went into ecstasies over and made M. Joseph famous. Next, a wealthy American—one of the very wealthiest—was taken by a party of friends to M. Joseph’s, not necessarily to partake of *canard sauvage*, but to patronize the pet restaurateur of the day, and they commissioned him to prepare a dinner for them of his own choosing, which he did; a thoroughly simple dinner of roast quail and a few other viands, with which they were so delighted—because it was prepared by the only M. Joseph—that they ordered the same for the next day and for several succeeding days. After they were gone their ways a great Parisian café secured the services of M. Joseph, just as

an operatic manager secures a star performer, and he officiated at a silver chafing dish with a silver duck-squeezer; and, later and latest, he was enticed away from the café by the very wealthy citizen of the United States by the offer of a very large salary, and is now in this country in private service. Such is, in nearly every case, the history of the rise of the high-priced, fashionable restaurant—there is a natural adaptation of a cook and an enthusiastic love of his profession; then the patronage of wealthy admirers and it is an accomplished fact. But where is the restaurant in the case of M. Joseph? Most probably it is coming. We are not writing of the restaurant of the last century. M. Joseph is of to-day; his restaurant may come tomorrow. Some morning the papers will say: "Delmonico is likely to meet with a formidable competitor shortly, in a magnificent restaurant after the Parisian fashion, to be opened by the \$10,000 M. Joseph, the famous ex-chef to Mr. Vanderbilt," etc., etc. They all aspire to it. Did not President Arthur's *chef* open a restaurant? Did not Presidents Hayes' and Garfield's steward open a restaurant? What became of them afterwards does not belong to the story. When the hero and heroine of a novel get married the interest ceases and the story ends. Likewise, every man thinks to get to keeping a high-class restaurant is heaven—until he has a chance to try it.

#### A TYPICAL AMERICAN RESTAURATEUR.

As true a type as the French M. Joseph of the restaurateur, as distinguished from the hotel keeper by all the traits we have already enumerated is the American, Mr. Taft, pictured below. He must indeed be an enthusiast, as the correspondents all agree in calling him, to carry his hobby of keeping everything that can be called for always on hand to such a successful extent as is described. Says one, recounting a visit to the place:

"Taft's is a great institution, and the person who visits Boston and does not go there has seen, or rather eaten, nothing.

The fish dinners gotten up at that famous resort are not equalled, probably, anywhere in the world. Mr. Taft is an old gentleman of over seventy, thin and tall as a rail, with snow-white hair. He is the greatest enthusiast we ever saw. It is a sight to see him bring in dish after dish, every one prepared under his personal superintendence, and carry it around the table for the inspection of every guest. His face is all aglow with pride and excitement and his features plainly say: "What do you think of th t? Isn't it magnificent?" We asked him were he learned to cook. 'My mother chucked me under the kitchen table when I was three weeks old and there I stayed,' was his answer; and we believe him. Dinners of twenty and more courses are common occurrences here, and the charges are not exorbitant. The old gentleman was asked why he brought the 'turbot,' which he claims is the finest fish, in the world, first on the table. 'Ah,' he replied, 'the best, to be fully appreciated, must always be eaten when the appetite is keenest; then you relish it immensely.' Logic which certainly proved correct in our case, for we thought that turbot the finest thing we had ever tasted."

Taft has a printed bill of fare or card of what can be had at his establishment, in which it is his pride to enumerate nearly all the edible birds and fishes, ending with humming birds served in nut shells. The list has been printed in the newspapers as a curiosity frequently. It would be impossible to give a more graphic and interesting account of the man and the place, or particulars more readable to restaurateurs than this from the *Philadelphia News*. It is better than a lecture on restaurant-keeping. This writer remarks:

"Taft does not serve *general* meals as does a restaurant," but it does not imply that Taft's is not the truest kind of a restaurant, it is one devoted to the specialties of fish and game, the very opposite of the *table d'hote*; a place where 'you can easily run your bill up to forty or fifty dollars' for dinner.

“Boston has what I consider the greatest gastronomic prize in the world in Taft’s. The name stands for both the man and the place. I can truthfully say of it that the *bon vivant* who confesses ignorance to his and its existence has no right to claim that he has lived. Taft? I hear you say. I don’t suppose there are a hundred men in Philadelphia who ever heard the name before, and yet it is the only place in the wide world where you can obtain any edible fish that swims, perfectly cooked. Only one divinely inspired can cook a fish. A man of fair culinary education can accomplish marvels with meats and vegetables and sweetmeats, but how few of even our famous *chefs* can give a fish that delicate treatment without which it has no temptation for the educated palate. At Gloucester, in the planked shad, we have a dish that should stand second in the list of piscatorial delicacies. The first place should unquestionably be given to the turbot as cooked at Taft’s.

“Taft is a white-haired octogenarian who owns a roomy frame structure on the shore of the Atlantic Ocean at Point Shirley, seven miles from Boston. I took dinner there two weeks ago, but it lives in my memory as vividly as though it were yesterday. I can never forget it. Old Taft entertained us for some time when we entered the parlor with reminiscences of the famous men who have visited his house. When Charles Dickens was in this country he and Nathaniel Hawthorne, Henry W. Longfellow, Charles Sumner and John W. Forney frequently sat together in one of the little dining rooms. Taft takes great delight in exhibiting the treasures of his larder. Men who have visited his house send him trophies of the gun and rod from every quarter of the globe. I thought I would nonplus him when he proudly said: ‘Gentlemen, I can furnish you with any edible fish or bird that you may name.’ I said: ‘Have you any reed birds?’ He looked at me quizzically and said: ‘You are from Philadelphia?’ I said: ‘What makes you think so?’

‘Because,’ he replied, ‘it is the only place in this country where you get reed birds—except here,’ and he held up a bunch of little bursting balls of golden fat—the little cherubs that the Philadelphia epicure bows down before and worships. He showed me even plump little humming-birds, each one snugly packed in the half of an English walnut shell. But his display of fish! It makes my mouth water to simply think of the tempting sight. He had every finny delicacy I had ever heard of and many that were entirely new to me, even by name. ‘Try again,’ he said to me, laughingly. ‘Perhaps you can name a fish I haven’t got.’ I naturally thought that the simplest of all, and yet one of the sweetest, would be forgotten in this wonderful array, and so I said: ‘I want some Schuylkill catfish.’

“‘Now I know you are from Philadelphia,’ he said, smilingly, as he reached far down in a big ice box and produced a string of our humble ‘catties.’

“Taft does not serve general meals as does a restaurant. He will provide you with a strictly fish dinner or a strictly game dinner or a combination of both. For the fish dinner, which is really a culinary marvel, he charges two dollars without wines. For what he terms his ‘regular’ game dinner he charges three dollars and a half, but if you wish to select from his larder what you wish you can very easily run your bill up to forty or fifty dollars, even though there are but three or four in the party. The dinner I partook of was especially ordered, and was a combination of both fish and game. I want to say right here by way of apology for the tale I have to tell that the appetites of myself and companions had been sharpened to a keen edge by a carriage ride of seven and a half miles in ‘a nipping and an eager air,’ salted with the spray that the wind swept in from the bosom of the broad Atlantic.

“We began the feast by each one consuming about fifty steamed clams—not the tough little morsels that we call delicacies,

but the long, soft shell tid-bits, of which you eat only the sweet morsels at the end after you have dipped it in melted butter. Fifty are looked upon as constituting only a moderate appetizer. Each dish that followed this was labeled by a small card bearing in letters of gold the name of the subject about to be discussed and held in place and aloft by a toothpick piercing both the card and the fish or bird, whichever the dish happened to be. The first dish proved the *piece de resistance*. It was a large turbot. The card bore this legend:

.....  
 TAFT'S TURBOT.  
 KING OF THE SEA.  
 .....

"It was truly a beautiful sight. At the edges it was of a creamy white, that deepened on the sides into a golden hue that became gradually richer and richer, until at the top it became a delicate brown. And then what snowy flakes it broke into under the fork! And what sweetness when it entered the mouth! I can truthfully say that I have never eaten fish before. Its memory haunts me still. I confess that when I had fully realized the wonder of that turbot I reached over the table and seized that little card, and I have it before me now.

"The next fish placed before us was a rock cod, which was excelled in delicacy and sweetness only by the glorious turbot, of which, by the way, we did not leave one morsel. Taft accompanied each dish into the room and for our especial benefit delivered a brief dissertation on its merits. The rest of the banquet consisted solely of game. The list may make your mouth water. We had chicken grouse and Lake Erie teal, both the finest I ever tasted in my life; jack snipes, peeps—wee little birds and very toothsome; reed bids—not equal to those of Philadelphia; and last of all humming birds cooked in nut shells. The last were really not worth eating, being dry and tasteless. But I wanted to say that I had eaten a humming bird, and now I can say it. Taken altogether, it was a

banquet fit for the gods, and it made me feel glad that I was permitted to live—and to be at point Shirley!"

#### THE RESTAURANT STEWARD AND THE MARKET MEN.

Mr. Taft evidently experienced keen enjoyment in his avocation, yet it may be doubted whether he, being practically without competitors, ever knew the supreme exultation of the city restaurant steward who "get's a scoop" on all his rivals in the business by securing the entire supply of some coveted delicacy and compelling the best patrons of other establishments to come to his place for it. He may have absolutely all the frogs' legs the city contains, and the blissful knowledge that no more can arrive for a week; or all of the early chickens, or the very last quail and partridges. And such being the object of his ambition, he must think of ways to gain the preferences of the market and commission men, for if he fails to make friends of them, unless he has very good private sources of supply from outside markets, he may as well quit the business. When a thing is cheap and plentiful he will be solicited to buy even if disliked and despised, but then he does not want it; and when it is scarce and in demand, he may hear of its being obtainable at this or that restaurant, but if not in the circle of favorites the dealers will take great pains to be "just sold out" every time he tries them. And still his favored rivals are getting all they want from hidden stores for days in succession. Many a new restaurant that is opened with a display of gilding and plate glass fails of success through this unconsidered particular of not having a steward or buyer who can secure the good will of the dealers in specialties, the game dealers, fish importers, the merchants who can always obtain everything worth having; not depending upon the northern markets alone, nor the southern markets alone, but wiring to fifty places if necessary; knowing where the goods are to be found. Without this com-



mand of the markets, and the co-operation of the market men, the restaurant fails from inability to "fill the bill." After two or three disappointments the most profitable patrons become chagrined and pass the place by with the contemptuous remark: "Oh, you can *never* find anything there."

#### HOW TO "STAND IN" WITH THE MARKET MEN.

The surest and best way to secure favors from the dealers is to be in a measure independent of them by opening communication with the same sources of supply which they draw from, at least often enough to show them that their withholding of supplies in favor of old friends will not have the effect of destroying the new restaurant, which may possibly, by reaching out, even gain advantages over all the older houses, and wake them up to a realizing sense that they don't yet own the earth. This, however, is only possible with a command of capital to stand occasional losses. Some, having but a limited business, can join another party, or several whose places are far enough apart not to compete, and import profitably that which one alone could not afford.

Next best way to secure a fair share and even a preference in what is going, is to pay cash on the spot. Old friendships and well-ripened business relationships may be strong, but cash in hand will draw the last and best thing from the darkest back corner of the refrigerator when the other fellow is not looking, nevertheless.

To stand well with the market men it is not necessary to attempt bribery, or to buy favors in that way. There is a good deal in having a pleasing address and sociable ways, but there is a kind of reciprocal accommodation which these dealers, being business men, appreciate above everything else—they want the buying steward to help them out occasionally when their enterprise has led them to bring on too much stock which threatens to spoil on their hands. They will not urge the man

they have sometimes favored with the things that were scarcest to help to unload them in a glut, but if on once asking he does not see what is the matter, and do what he can afford by taking more or less, they are liable to remember it against him at some future time when perhaps they will have the only basket of turkeys or sucking pigs in the whole city, and he wants them badly.

#### KEEPING PROVISIONS.

Not the least of the means of keeping abreast with the foremost in the trade is a thorough knowledge of how to keep provisions after they have been procured. The best restaurants have refrigerators of special make, cold rooms, fitted with drawers and shelves in which prepared provisions are kept awaiting orders to cook them. In some places the main dependence is upon large ice boxes containing broken ice, and cotton sacks full of small quantities of such things as are not injured by being kept wet are buried deep in the ice where they keep for a long time.

#### A FIRST-CLASS RESTAURANT BILL OF FARE.

Regarded as reading matter a bill of fare may not have very strong claims upon the attention, but as showing what need the restaurateur has of extensive acquaintance with the markets and of ways and means of keeping a vast number of articles in good condition when secured, the grand bill of fare here shown must prove an object of lasting interest. Merely as a list of dishes for the composition of bills of fare it will be found useful; as a list of prices charged where prices are the highest it will serve to brace up the timid ones who don't know how to charge. Two dollars and a half, it must be admitted is a good "live and let live" price for a beefsteak—see the list of "Dishes to Order." A portion of the price of every dish in this place was needed, however, to pay for the music of Gilmore's band playing outside.

# Manhattan Beach Hotel.

Guests will please Pay their Checks to the Waiters, and see that Prices charged correspond with those on Bill of Fare.

## BILL OF FARE.

SATURDAY, JUNE 14, 18—

### SHELL FISH

Little Neck clams on half shell.....	25	Clam, roasted.....	40
Clams, stewed.....	40	“ Little Neck, roasted.....	50
“ fried.....	40	“ steamed.....	40
“ fritters.....	40	Plain lobster.....	40
Soft shell crabs.....	50		

### SOUPS

Consommé.....	25	Printanier Royal.....	35
Clam chowder.....	25	Mock Turtle.....	40

### FISH

Baked bluefish, wine sauce.....	45	Boiled sheepshead, hollandaise.....	60
Eels, tartar sauce.....	50	Connecticut River salmon broiled.....	50
Striped bass, broiled.....	40	Spanish mackerel.....	50
Bluefish.....	40	Blackfish.....	40
Sheepshead.....	50	Sea bass.....	40
Fresh codfish.....	40	Filet of sole, tartar or tomato sauce.....	50
Fresh codfish, hollandaise.....	50		

### BOILED

Leg of mutton, caper sauce.....	50	Turkey with pork.....	60
Corned beef and cabbage.....	45	Chicken, Florentine sauce.....	75
Ox tongue with spinach.....	45		

### ROAST

Ribs of Beef.....	40	Spring chicken with cresses, whole.....	1 50
Lamb, mint sauce.....	50	“ “ half.....	75
Spring turkey.....	60	Ham glacé, champagne sauce.....	50

### ENTREES

Blanquette of Veal à la Poulette.....	60		
Poulet sauté à l'Estragon.....	75		
Lamb's Kidneys à l'Italienne.....	60		
Lobster Croquettes aux fines herbes.....	60		
Frog's Legs sautés à la Hollandaise.....	60		

### GAME

Pigeon.....	50	Philadelphia squab.....	60
English snipe, on toast.....	50	Plover, on toast.....	60

### VEGETABLES

Potatoes, boiled.....	10	Potatoes, à la Parisienne.....	20	Macaroni à l'Italienne.....	25
“ fried.....	10	“ à la Lyonnaise.....	20	Spaghetti.....	30
“ Saratoga.....	10	Boiled rice.....	15	French peas.....	35
“ mashed.....	10	Stewed tomatoes.....	20	Stuffed tomatoes.....	30
“ à la maître d'hôtel.....	15	Green peas.....	25	Canned corn.....	20
“ sautés.....	15	Asparagus.....	25	French string beans.....	35
		New beets.....	20	String beans.....	25

### SALADS, RELISHES, ETC.

Lettuce, plain dressing.....	25	Watercress.....	20
“ with egg.....	30	Currant jelly.....	15
“ with mayonnaise.....	35	French or English pickles.....	15
Potato salad.....	20	Chow chow.....	15
Sliced tomatoes.....	25	Olives.....	15
Tomato salad, mayonnaise.....	35	Pickled beets.....	10
Cucumbers.....	20	Radishes.....	10

**PASTRY AND ICE CREAMS**

Charlotte russe.....	15	Eclairs.....	15
Apple pie.....	15	Lady fingers.....	15
Peach pie.....	15	Fancy cakes.....	20
Pineapple pie.....	15	Blanc mange.....	20
Custard pie.....	15	Cabinet pudding.....	20
		Rum Jelly.....	25
Chocolate ice cream.....	25	Lemon ice.....	25
Vanilla or strawberry ice cream.....	25	Tutti Frutti.....	25
Meringue glacée.....	30		

**FRUIT**

Strawberries and cream.....	25
Oranges.....	20
Rum omelette.....	35

**DESSERT**

Pecan nuts.....	15
Almonds.....	15
Mixed nuts.....	25
Raisins.....	20

**CHEESE**

American.....	10
English.....	15
Swiss.....	20
Neufchatel.....	20
Stilton.....	25

**PRESERVED FRUIT**

Strawberries.....	25	Brandy peaches.....	35
Ginger.....	25	White cherries.....	25
Damsons.....	25	Orange marmalade.....	25

**COLD DISHES**

Roast beef.....	40	Corned beef.....	40	Chicken salad.....	65
“ turkey.....	60	Ham.....	40	Lobster salad.....	50
“ lamb.....	50	Beef tongue.....	40	“ plain.....	40
Half chicken.....	60			Sardines.....	35
Ham sandwich.....	15	Tongue sandwich.....	15		
Corned beef sandwich.....	15	Chicken sandwich.....	25		

**DISHES TO ORDER**

Beefsteak, plain.....	50	Squab broiled with cress.....	60
“ with onions.....	60	“ with peas.....	80
“ with mushrooms.....	75	Sweetbread broiled.....	70
Sirloin steak.....	75	“ à la macédoine.....	75
“ with mushrooms.....	1 00	“ with French peas.....	85
Tenderloin steak.....	80	“ with mushrooms.....	1 00
“ with madeira sauce.....	90	Mutton chops.....	50
“ with mushrooms.....	1 00	“ sauce piquante.....	60
“ à la Borde'aise.....	1 50	“ with peas.....	70
“ with truffles.....	1 50	“ à la jardinière.....	70
Filet Châteaubriand, plain.....	1 50	Lamb chops, plain.....	60
“ with mushrooms.....	2 00	“ à la Soubise.....	75
“ à la Trianon.....	2 25	Calf's head à la vinaigrette.....	50
“ with truffles.....	2 50	“ à la poulette.....	50
Porterhouse steak, plain.....	1 25	“ en tortue.....	80
“ with mushrooms.....	1 75	Chicken broiled on toast (half).....	60
“ extra large, plain.....	2 00	“ sauté with mushrooms.....	1 00
“ mushrooms.....	2 50	“ à la bordelaise.....	1 00
Veal Cutlet, plain.....	50	“ à la Marengo.....	1 25
“ breaded, tomato sauce.....	60	Welsh rarebit.....	40
“ à l'Italienne.....	60	Golden Buck.....	50
“ en papillote.....	70	Soft shell crabs.....	50
Frog's Legs breaded.....	50		

**MISCELLANEOUS**

Cream toast.....	35	French or graham bread.....	10	Boston brown bread.....	10
Milk toast.....	20	Bread and milk.....	25	Plain bread.....	10
Dipped toast.....	15	Tea biscuit.....	15	Cream, per glass.....	20
Dry toast.....	10			Milk, per glass.....	10
Oolong tea, per cup.....	10	Green or Japan tea,		Chocolate, per cup.....	15
“ per pot.....	20	per pot only.....	20	“ per pot.....	25
Eng. Breakfast tea, per cup.....	10	Broma, per cup.....	15	Coffee, per cup.....	10
“ per pot.....	20	“ per pot.....	25	“ per pot.....	20

Iced Coffee, per glass.....15

Iced Tea, per glass.....15

A FEW ENTREES AND A LITTLE MANAGEMENT.

No matter how high the prices or how wealthy the establishment, it is found most difficult to keep a restaurant strictly on the "cooked to order" method; provisions, however well cooked, will remain uncalled for and must either be lost in large aggregate quantities or turned to the use of a regular dinner. Delmonico claims that consideration of the great loss of provisions which must be of the best, must be kept in readiness, yet must be parted with if in the least deteriorated, as his reply to the charge of keeping the dearest restaurant in the world. We see in this great bill of fare,

therefore, five fresh entrees every day, and scanning them with the eyes of experience we may find a judicious use to-day has been made of some good things which did not sell in the other lists where they appeared the day before. That much is borrowed from the hotel plan. A few good entrees are made and offered without waiting for the accident of their being ordered, and in that way they always sell well to the people who would much rather have somebody get dinner ready for them and call them to it than have the trouble of planning and ordering a dinner themselves.

This is the list of entrees which appeared the next day after the former bill, and shows the only changes made in the entire list.

ENTREES

Filet of beef larded à la Jardinière.....	70
Epigramme of spring lamb, tomato sauce.....	60
Calf's brains breaded, sauce tartare.....	65
Vol-an-vent of chicken à la Financière.....	80
Philadelphia squab, en crapaudine.....	70

The wine list printed on the fourth page of the original bill of fare folder was in small type as voluminous of items as the dinner list inside and the front page was taken up with the programme of the grand concerts.

THE MERCHANTS' LUNCH HOUSE.

Of a contrary description is the merchants' lunch house—a kind of restaurant that thrives by the necessities and not the luxuries of its patrons. One that is not obliged to secure new and inviting comestibles and not obliged to command the markets nor carry a varied stock. The lunch house restaurant is useful rather than ornamental; not sought for pleasure, but through the driving necessity of taking in some sustenance without delay. To live and be a business success it must be located in the most densely packed portion of the city, in cramped quarters and pinched up places on valuable ground, but easily accessible; then it must furnish something to eat and drink—it makes but little difference what—for the men whose pursuits are such as to prevent their going

far for their mid-day meal. There may be added to the main dining hall or counter, or whatever the feeding place may consist of, a few private rooms, perhaps an upstairs dining room with some pretensions to elegance, where men of some leisure or merchants who take a country customer to dinner may have a table to themselves and at least half of a waiter's attention. These conditions being secured a plain man with plain business sense may make an income which runs up into the thousands each year without much hard work or anxiety; without attracting the least notice or even bare recognition from his constant customers, who only come to his place because it is the nearest and is not very bad. This sort of a house has no business on Sundays and may as well close on that day as not. The few essentials to make it successful in the matters of the table are that it furnish the best of beef plainly cooked, the best of coffee, best butter and bread. All sorts of extras, of course, are offered and a good deal sold of fish and games and the ordinary pastries, but nobody's reputation is affected whether

ARTICLES HAVING NO PRICE ATTACHED NOT SERVED TO-DAY.

BOIS BLANC'S  
RESTAURANT AND MERCHANTS' LUNCH.

**SOUP.**

Beef Broth.....	15	Bean.....	15.
.....		.....	
.....		.....	

**FISH.**

Boiled Fresh Cod, Egg Sauce.....	35	Yellow Perch.....	
Trout Steak.....		White Fish, broiled or fried.....	
Fresh Mackerel.....		Yellow Pike.....	
Spanish Mackerel.....		Fresh Salmon.....	
Black Bass.....		Boiled Haddock, with Oyster Sauce.....	

**COLD MEATS.**

Lobster Salad.....	30	Potato Salad.....	15.
Chicken Salad.....	30	Shrimp Salad.....	40.
Bean Salad.....	25	Pickled Lamb's Tongue.....	25
Pressed Corned Beef.....	25	Baldwin Ham.....	25.
Smoked Tongue.....	25		

**ENTREES.**

New England Boiled Dinner.....	35	Cod Fish Balls.....	
Irish Stew with Vegetables.....	30	Beef à la mode.....	
Baked Chicken Pie.....		Boiled Leg of Mutton, Capers Sauce.....	
Chicken Fricaseed on Dry Toast.....		Pork and Beans.....	25
Tenderloin of Beef with Onions.....		Chicken Giblets on Toast.....	
Pigs' Feet.....		Boiled Turkey, with Oyster Sauce.....	40
Honey Comb Tripe, Tomato Sauce.....		Boiled Chicken, with Salt Pork.....	
Baked Macaroni with Cheese.....	15	Corned Beef Hash, with One Poached Egg.....	35
Minced Turkey, with One Poached Egg.....		Turkey Wings, Stewed, with Vegetables.....	
Chicken Pot Pie.....	35	Pork Tenderloin, with Fried Apples.....	35.
Pigeon Pot Pie.....		Veal Cutlets, Breaded.....	

**ROASTS.**

Loin of Beef.....	35	Pork, Apple Sauce.....	
Veal, Stuffed.....		Young Spring Chicken.....	
Rib Ends of Beef.....	25	Turkey, Cranberry Sauce.....	
Venison, Cranberry Sauce.....	40	Young Goose, Cranberry Sauce.....	
Saddle of Mutton.....		Canvass Back Duck.....	
Teal Duck, with Jelly.....		Mallard Duck.....	

**VEGETABLES**

Mashed Potatoes.....		Elgin Corn.....		Succotash.....		Sugar Beets.....	10.
Asparagus on Toast..	15	Squash.....	10	Stewed Tomatoes.....	10	Baked Sweet	
Lima Beans.....		Young Onions.....		Fried Parsnips.....		Potatoes.....	10.
Boiled Onions.....	10	Potatoes.....		Turnips, mashed.....	10		

**RELISHES**

Cucumber Catsup.....		Sweet Pickles.....		Cold Slaw.....		Worcestershire Sauce.	
Tabasco Sauce.....		Tomato Catsup.....					

**PUDDING AND PIES.**

Granula Pudding, Vanilla Sauce.....	10	.....	
.....		.....	
.....		.....	

..... Mince Pie, 10. Apple Pie, 10. Custard Pie.  
..... Lemon Pie. Cranberry Pie. Pumpkin Pie, 10

**MISCELLANEOUS.**

Codfish Tongues on Toast.....		Shrimps, per plate.....	
Scallops.....		Sardines, per box.....	
Frogs' Legs.....		“ “ for two.....	
Fresh Lobster, whole.....		Soft Crabs, per pair.....	
“ “ half.....			

**TEA, COFFEE AND CHOCOLATE.**

French Coffee, per pot.....	25	Coffee, per cup.....	10
“ “ with Cognac.....		“ “ pot, for one.....	15
Tea, per Cup.....	10	“ “ “ “ two.....	25
“ “ pot, for one.....	15	Chocolate, per cup.....	15
“ “ “ “ two.....	25	“ “ per pot, for one.....	25
		“ “ “ “ two.....	40.

**ALL FANCY AND MIXED DRINKS, CALL FOR.**

Budweiser Beer, Qts.....	30 cents;	Pints.....	20 cents.
Best's Milwaukee Lager Beer.....	10 cents.		

such dishes are good or not, or whether genuine or mere imitations and substitutes, and one who would try to carry out ideas of a better order of things would be left behind by duller competitors who are better fitted for the position. In short, the busy merchants, insurance men, lawyers, agents of all sorts, and proprietors of every business in the heart of a city experience a difficulty in finding a suitable lunch place, for the reason that in the locality where most wanted the rents are generally too high for lunch houses to pay; when some man does get a footing in such a place his custom is assured from the first with only a small effort on his part; his struggle is not to make his house and table most excellent, but to make it pay the rent and himself.

Such a necessity for a place to take a rapid lunch was felt by an enterprising firm of liquor merchants in Chicago some years back, and with more thought for the convenience of the thing than the rent value of the rooms they gave a restaurant man a chance by letting him have the necessary space in their own building at a nominal rent, and by the time they became tired of the rather one-sided arrangement, which was at the end of three years when they took charge of the place themselves, the restaurant man had deposited in the bank ten thousand dollars as his net profits. That on the preceding page was his bill of fare. He served no breakfasts and did not keep open on Sunday.

The bill was not too good, but just good enough; the prices were not too high, but just high enough. Nothing admirable about it further than that it is the bill of fare of a Chicago Merchants' Lunch that succeeded.

The same bill of fare would fit equally well another one of Chicago's most successful lunch house restaurants; Thompson's, however, very conveniently situated with plenty of room in a building to itself. Said the chief cook of the place to the writer, one day: "Yes, we serve all of

three thousand meals a day; they are nearly all to regular customers; never enough strangers among them to make any particular difference. We don't stop to garnish our dishes with parsley and lemons, you know, but what we give 'em is good, and we manage to give most of our customers seats at the tables; and I think the reason we do one of the biggest businesses of the kind is because we serve the meals quicker than any other place can. Why, good lord, sir! I can't tell you *how* we serve them quicker; but I have six carvers and each one has a rib roast of beef before him, and it seems to me they must carve a dish of beef apiece every two seconds, and that's about as fast as the people can come in at the doors—roast beef and mashed potatoes is thirty-five cents an order; if you want to count up, you can—as for me, you know, everybody doesn't take roast beef and what they do take, why that falls on me to look after with my other men. About thirty hands in the kitchen is what we have, and thirty or forty waiters, but some of them only work through dinner time."

Here, too, the breakfasts, though considerable, were light in comparison with the noon lunches or dinners. The proprietor of the place (recently deceased) was the owner of the building, a very valuable one, of which he used only the lower floor for his lunch house business, and, besides, died possessed of \$150,000, said to have been made in the restaurant business, which he kept by him in cash. He was an illiterate man, and was afraid to trust his money to the banks.

And close by—for all three of these places were situated in the same block—was a "fine" restaurant, where they *did* garnish their dishes and served every delicacy to order, and did really good work; but its patronage was small, and it changed proprietors three times in two years. It was the right kind of a restaurant in the wrong place, except for the demands of the few.

## THE BAKERY LUNCH.

One of the greatest successes among Chicago lunch businesses is remarkable for the narrow compass in which it is carried on and the lack of any outward indications that would lead a stranger to suspect its existence, much less to surmise the immense extent of the feeding done on the premises. It is a narrow store building with ordinary bake-shop windows showing some bread and cakes and no other sign. But signs are needless, the place within is taxed to its fullest capacity in every inch of space to meet the demands of a singing multitude of pie eaters, and no more can be accommodated; no more can get in. The pressure begins at twelve o'clock each day, and some of the more ingenious or less restrained among the customers manage their business so as to resort there for their pie and milk between the hours of eleven and twelve, and so avoid waiting in line for the stool of their choice; after noon and until two o'clock there is no other chance, but to stand and wait for a turn, loving the men in front who take custard pie, because they can swallow it quickly and move on, and hating them that give the unusual order for ham sandwiches, two courses of apple dumplings or meringoes and iced coffee with a straw, because that means delay for the men who stand behind.

Great stories have been told of the enormous amounts of pastry of all kinds consumed at this principal bakery lunch house of the city, and the hundreds of thousands of customers served each year, but this is not to our purpose. There is a suggestion in it, however, that almost every town of consequence would support well a bakery lunch house carried on in the right way: serving the very best of pastries of all varieties in liberal portions at a small price. The profit on each customer is necessarily small, but the aggregate, like the two cent stamp business of a post office, soon runs up to hundreds and thousands. The various pastries and cakes

are produced in these large and successful establishments by the best bakery machinery and baked in rotary ovens of enormous capacity. It is often asked why such crowding as these places show should be allowed; why more roomy quarters are not provided and better accommodations. But, probably, the conditions noted are the only ones possible; to attempt to change the business would destroy it. It is the public need that builds up such a trade; the men who own the business do not make the tide, they only ride upon it.

## THE PLACE AND NOT THE MAN.

Examples of successful places where the man and his efforts amount to nothing, but the location is everything, are plentiful enough. Here is a sample of a curious kind of business dependent only upon the time and place, mentioned by a foreign correspondent:

"One of the minor industries in the Parisian catering trade is that of the vendors of milk in the early hours of the morning, who are to be found under the *portes-cochere* of a house in almost every street, and who supply the public with *cafe-au-lait*, chocola'e, hot milk, crescents and rolls, besides cold milk. The hot drinks can be consumed on the premises, a bench or two and a table being at the customer's disposition. In some parts of the town these enterprising ladies do a rattling business in spite of the short hours allotted to them, and the comparatively high rents they have to pay. In the house where I live, the *laitiere* pays ten pounds, about \$48.50, per annum for the use of the doorway and entrance for two hours every morning, from 5.30 to 7.30, and yet I believe she does a famous business. In other parts of the town the rent is still higher, rising to twenty pounds per annum in very crowded thoroughfares. The prices are 1d. a cup of hot milk, and 1½d. for a large bowl of hot coffee and milk, or chocolate."

But that is very much like our southern "French market" stands, the rents in the market stalls being high enough for the few morning hours they are occupied.

## THE MAN AND NOT THE PLACE.

On the other hand here is a present instance of a man changing utter disaster into remarkable success in spite of the

place. When prohibition struck Atlanta with the usual inevitable effect of breaking up many a prosperous man's business, it extinguished for a moment the proprietor of one of the best, most respectable and most profitable bars on the main street of the city, and, likewise, his popular head barkeeper, whose occupation certainly was gone completely. The building, like scores of others, seemed to be of no further use, was dismantled of its bar fixtures and stood deserted. But an idea struck the proprietor to open a merchants' lunch and restaurant in the place, and his popular barkeeper should be the steward. Neither of them had had restaurant experience, but the owner had capital and business capacity, the amateur steward had a pleasing face and a real interest in making everybody feel well, and their success has been amazing. The city is spoken of far and wide as one that will not support a good restaurant; the business has been tried time and again, before and since, and everybody fails except these whilom liquor sellers. Their place has progressed from stove to small range; from that to large range; from that to hot-water tanks and steam-cooking and a hot carving table; from that to renting a run-down sort of boarding house up stairs and changing the whole thing into a fine "European Hotel." When the prohibition legislation was repealed this place did not go back to the old bar business as others did with a rush, but keeps on in the new line of success. Natural adaptation to the business is the secret of success in this case, both men know what is good themselves, and buy only what is good, and if the jolly ex-barkeeper, now steward, is the cheerful giver, the owner is the careful manager, and they are both in love with what they are doing. It would be space wasted to print their bill of fare—their show window is their best card, nor would it profit to repeat the stories told of the large amount of money made, such are always exaggerated, sufficient it is to know that their success is of the substantial kind that satisfies them.

#### THE BAR ROOM FREE LUNCH.

And yet, after all, perhaps the bartender of the preceding instance gained an insight of the restaurant business through the practice prevalent in some cities of serving a roast-beef-and-trimmings lunch free to patrons of the bar. New Orleans is called the original home of the free lunch, and it is true to-day that the best lunch obtainable in that city can be had at the bar-rooms; not free to all, but upon payment of fifteen cents for drinks of some kind at the counter. There is a soup, fish, roast beef of the very best quality, salads of beets and potatoes, and bread. The best cooks find easy employment on these hot lunches and similar midnight suppers. The excellence of the repasts furnished at such merely nominal rates has much to do with the making New Orleans the poor hotel city it is known to be. The stranger in the city who does not know of the free hot lunches at the liquor palaces knows nothing. New Orleans has been famous for its restaurants, also, but the reports vary according to the humor or the good or bad fortune of some visitor who writes about them. To avoid going over old ground, to show that restaurants are the same the world over and that the same complaints fit St. Petersburg that would apply to New Orleans let us append this growl of an Englishman in

#### A RUSSIAN RESTAURANT:

"If, however, you wish to attempt one of the fashionable restaurants in the Great Morskaja, two hospitable houses on either side of the way open wide their tempting portals. Which shall it be? Desseaux on the right, or Borel on the left? Scylla over the way, or Charybdis on this side? For surely neither Scylla nor Charybdis ever seized the unwary traveller with such irresistible force, or devoured him to such good purpose.

"Entering Desseaux's 'Restaurant des Nobles,' you are received with civility amounting to obsequiousness. One small waiter relieves you of hat and stick; another, a little larger, removes your great-coat; and a third, quite full-sized and rather fat, awaits your instructions with a winning



smile and many low bows. 'Nyet Russki' should be your first remark; and the fact of your being a stranger being thus ascertained, No. 3 disappears and fetches the linguist of the establishment, a very portly man, who asks you for your orders in fair French. An *habitué* would reply, 'A plain soup, a mutton cutlet done on the grid, a roast *gélinotte* and salad, Russian beer;' but you, a stranger, overawed by the stout linguist, by his magnificent shirt-front, and above all by the morocco-bound, gilt-edged, brass-clasped bill of fare, as formidable as a family Bible, which he holds out for your inspection, will not think of ordering so simple a dinner. And if you have an inclination that way, the sight of three huge champagne-coolers, containing long-necked bottles, which grace a table occupied by a couple of young Guardsmen in their gorgeous uniform, will remind you that you did not come to Desseaux's for a chop and a glass of beer, and that more is expected of you, although you don't know what to order. But some feeling akin to pity, some recollection of the days when he too was a stranger in a foreign land, seems to stir within Mezzofanti's broad bosom. For instead of allowing you to flounder hopelessly through fifty-eight stiff pages of the bill of fare, he kindly helps you by suggesting that perhaps you would like *le diner du jour*; and at the same time he produces an elegant *menu*, printed in dark-blue on cream-tinted paper with a flowery pink border. The cream-tinted paper appears to you like the flag of hope; it is the traditional straw at which the drowning man clutches, and you gasp 'Oui, oui,' hysterically. Thus you have chosen—you must eat, not what you like, but what suits Desseaux's pocket; and you drop down on one of the comfortable sofas in the pleasant dining-room, and hear the young Guardsmen exchange opinions (in bad French) about the last new dancer at the Theatre Berg, till soup arrives, and with it another magnificent volume—this time the wine-list, naturally open at the page containing champagne at six roubles and upward. But you are not to be taken in, and turning back, select a pint bottle of St. Julien at two roubles—a good, safe wine, you imagine you know. After the soup (which is good, but enriched with too many quenelles, croquettes, etc.), and the inevitable petits pâtés, you get stewed beef, which you recognise as first cousin to the Rindfleisch of Germany and the bouilli of France; only the latter costs sixpence a plateful, while his Russian relation is more expensive and more stringy. To console

yourself, you turn to the St. Julien. What is your horror at finding a sweet, fiery compound, of which the curious astringency evidently proceeds from sloes, and which has nothing common with French wine except its color! You proceed naturally to sterlet (a small fish of the sturgeon family) *a la Russe*, which perhaps you will like. But after this rich dish you feel the want of a little good wine, and therefore rather indignantly have the pretended St. Julien removed, and order half a bottle of Margaux. Calf's head stewed *a la financière* follows, and would be good in its way if it were not too rich, like all Russian dishes. The Margaux now arrives, and proves to be a little more fiery and a little less sweet than the St. Julien, but no more like claret than its predecessor. However, it drinks better when diluted, or perhaps you are getting used to it. God forbid the latter! for then your palate is hopelessly blunted, your taste gone, and you will never again appreciate the Sauterne of the Maison Dorée or the delicious Lafitte of Bignon! However, a dish of intensely green peas now appears, and you only find out when you try them that they are preserved, and very badly preserved, too. At last comes the roast, and if Desseaux does his duty it will be fowl, and not game; for the former is much more expensive, and therefore considered more delicate. Desseaux *does* his duty, and you have the pleasure of carving a chicken about the size of a large sparrow, and consisting of skin, bone, and a few stray feathers. This fine bird is accompanied by pickled cucumbers, but as both your own aversion and your doctor's orders prevent your partaking of this Russian substitute for salad, you feel that you have hardly dined, although you have finished dinner. You order a little cheese, then coffee and liqueur; and when your bill is brought, you philosophize on how much a man can spend on his dinner without getting enough to eat or anything fit to drink. Here it is:

	Rbs.	Kps.
Dîner.....	3	0
Pain.....	0	20
St. Julien.....	2	0
Margaux.....	3	0
Café.....	0	40
Liqueur, etc.....	0	40
Fromage.....	0	40
	9	40, or £1 7s.

And, let it be added, Desseaux is *not by any means the dearest* restaurant in St. Petersburg, *nor the worst.*"

An odd coincidence! That sketch of a St. Petersburg restaurant brings us back to

Manhattan Beach and the great bill of fare. There is the same soup, the same something *a la financiere*; the same *diner du jour*—dinner of the day—with perhaps the same five entrees; the same *fromage* and things at about the same prices and the same wines. The restaurants of that class are all alike.

#### THE OYSTER AND FISH RESTAURANT.

For something different from the conventional style of first-class restaurant and which may be claimed as peculiarly American, we turn with pleasure to the first class oyster house, very probably the source of more real enjoyment combined with a sufficiency of tone or style than any other class of public eating house whatever; and as sea foods, in the natural order of things, become the greater luxuries in proportion to their distance from the sea, we shall find the best specimens of the oyster and fish house in the very centers of the continent, in the large cities of the interior, probably nowhere better than in Chicago. All that the famous gourmands and epicures named in history could do was to obtain rare and costly kinds of meats and fish, and make them more costly still by obtaining them from immense distances whither their competitors and their purses could not reach, and even the king of romancers, Dumas, could imagine no higher achievement for one of his most sumptuous heroes than his feat of procuring a rare and peculiar fish found only in one particular river of the world, brought across the wilds of Russia in a tank of water and landed in Paris alive, to be served at this wonderful entertainer's next reception. The railroads and express service have done much to bring all parts of the country to the same dead level of equality of markets, and yet there is a small fence of exclusiveness raised around the inland oyster house by the express charges and "oysters on the half shell," which may be too common at ten cents a dozen at a fish stall on the sea-board for their intrinsic excellence to be really appreciated, when enhanced in

flavor by so much per pound charged for transporting them a thousand miles or more become a luxury worthy of the mirrored marble and mahogany halls and elaborate styles of service and all accessories of the best Chicago oyster houses.

The fine restaurants make the most of the great American specialty, oysters, in all styles, employing the best cooks in that peculiar line that money can procure and adopting every new device for presenting the luscious bivalve in the most tempting forms. In addition they serve fish of every saleable variety, shell fish such as lobsters, crabs, clams, crayfish, scallops and, since Dumas' *file*, *salade Japonaise* has gained notoriety, the humbler mussel which enters into its composition. Salads of all sorts, but more especially fish salads, are made here in perfection. Very little attention is paid to the ordinary meat dishes of the restaurants, yet a steak or chop with potatoes can be had if any member of a party happens to have a distaste for fish foods. While these oyster and fish houses do a good business at all times of the day they are in their glory only at night, when, after the ordinary closing hours of business and the closing of theatres and other places of amusement, they are crowded to their utmost capacity and long charcoal ranges are covered with oysters roasting in the shell, clams likewise, and further on with broils, fries, stews, soups, steams and chowders. The chief drawback to this business is that it must take a vacation during three or four months of summer, when oysters are out of season; or the business must be temporarily changed to something to suit the time and re-organized every fall. The following appended as a sort of guide to prices for any one entering the business is the bill of fare of a Fulton market oyster and fish house. Considering the location it ought to show the bottom prices which a good house can afford to accept close to the chief source of supply; Chicago prices ought to be and probably are higher, and Denver or other more distant cities should obtain prices higher still:

AN OYSTER AND LUNCH ROOM.  
**Bill of Fare**  
*FULTON MARKET, NEW YORK CITY.*

**SOUPS.**

Ox Tail Soup.....	20	Bisque of Oysters.....	20
Chicken Soup.....	20	“ “ Clams.....	20
Green Turtle Soup.....	40		

**OYSTERS.**

Saddle Rock Roast.....	35	Plate of Raw.....	20
“ “ Fry.....	35	Stew.....	25
“ “ Stew.....	35	Boston Stew.....	50
“ “ Raw.....	35	Fancy Broil.....	50
“ “ Broil.....	35	Box Stew.....	30
Extra Saddle Rock Roast.....	50	Oyster Fritters.....	35
“ “ Fry.....	50	Pickled Oysters.....	25
“ “ Stew.....	50	Oyster Pattie.....	25
“ “ Broil.....	50	“ Fricassee Oysters.....	35
“ “ Raw.....	50	Saddle Rock Fry in Box.....	35

**CLAMS.**

Steamed Clams.....	35	Clam Fritters.....	35
Clam Chowder.....	25	Saddle Rock Clam Fry.....	35
“ Stew.....	25	“ “ Stew.....	35
“ Fry.....	35	Raw Clams.....	20
“ Roast.....	35	Stewed Scallops.....	25
Fried Scallops.....	35		

**FISH.**

Crab Salad.....	50	Smelts.....	40
“ Omelet.....	50	Codfish.....	40
Blue Fish.....	40	King Fish.....	40
Weak Fish.....	40	Sea Bass.....	40
Mackerel.....	40	Black Bass.....	40
Striped Bass.....	40	Deviled Crabs, per doz., to order.....	1 50
Fish Cakes.....	30	Salmon Steak.....	50
Plain Lobster.....	35	Soft Crabs.....	50
Lobster Salad.....	40	Pompano.....	75
Stewed Lobster.....	40	Spanish Mackerel.....	50
Lobster Pattie.....	35	White Bait.....	50
Eels.....	40	Fish Chowder (Fridays).....	25
Halibut.....	40		

All other kinds of Fish in Season.

**MEATS, ETC.**

Porterhouse Steak.....	75	Cold Boiled Chicken.....	40
“ “ for two.....	1 00	Sweetbreads.....	50
Double Porterhouse.....	1 25	Broiled Chicken.....	60
Tenderloin Steak.....	60	Chicken Salad.....	50
Sirloin Steak.....	50	Chicken Pattie.....	40
Roast Beef.....	40	Liver and Bacon.....	40
“ Lamb.....	40	Ham and Eggs.....	40
Mutton Chops.....	40	Scrambled Eggs.....	25
Veal Chops.....	40	Poached Eggs.....	25
Lamb Chops.....	40	Two Eggs (Boiled or Fried).....	15
Boiled Ham.....	30	Plain Omelet.....	25
Fried Frogs.....	50	Ham “.....	35
Sandwich.....	15		

**VEGETABLES.**

Celery.....	20	Fried Sweet Potatoes.....	15
Egg Plant.....	20	Stewed Potatoes.....	10
Green Peas.....	15	Lyonnais Potatoes.....	10
Asparagus.....	15	French Fried Potatoes.....	10
Stewed Corn.....	15	Saratoga Potatoes.....	10
Green Corn.....	15	Tomatoes (Stewed or Raw).....	10
Cucumbers.....	10		

**DESSERT.**

Home-made Pies.....	10	Water Melon.....	10
Rice Pudding.....	10	Musk “.....	20
Farina Jelly.....	10	Corn Starch.....	10
Peaches and Cream.....	20	Ice Cream.....	15
Apple Fritters.....	20		

**MISCELLANEOUS.**

Coffee.....	10	French Pan Cake.....	25
Tea.....	10	Wheat Cakes.....	15
Pot Tea.....	15	Rolls, each.....	5
Extra Pot Tea.....	25	Chocolate.....	10
Coffee or Tea and Roll.....	15	“ Iced.....	10
Crackers and Milk.....	15		

**CAME.**

English Snipe.....	60	Squab on Toast.....	60
Other Game in Season.....			

## HOW THE PAY IS COLLECTED.

One purpose of going over the different classes of business in a talk about restaurant stewarding was to observe the different methods which restaurateurs adopt for collecting the pay from customers. Many men think this is the most difficult department to control of all in the business, and no man pretends yet that he has found a perfect plan for getting all the money that is due him. In a very small personal business it may be quite easy for the proprietor to keep watch of each customer's order and remember the amount, but the difficulty increases as the volume of trade grows larger and personal watching is given up altogether and some plan instituted which affords protection both to customer and owner. It is pleasing to think that honesty is the rule and the contrary the rare exception, yet these exceptional cases give a world of trouble and uneasiness, and in the largest cities, where thieving is the trade of a few, the opportunities afforded by the crowded restaurants and lunch houses are duly improved and every device of ingenuity is brought into play by expert thieves in waiters' dress to intercept the money paid in by the customers on its way to the cash box, one of the commonest being to overcharge the customer and keep the extra money themselves. The most noted and successful Parisian restaurateur of the present time, according to the story-tellers of the press, was at one time on the very verge of financial ruin although doing an immense business, and was only saved from the final crash and lifted up to great wealth by the discovery of an effective system of checking meals as sold.

## THE COMMON MEAL CHECK.

The common way and which seemingly is good enough for a small business is to provide small cards printed with the small sums and perhaps a line or two, as:

YOUR BILL IS  
**20 Cents.**  
PLEASE PAY AT THE CASHIER'S  
DESK.

These are kept in separate compartment boxes like silver change according to their denomination; the headwaiter or cashier or cook, or whoever has the responsibility of keeping them in charge, hands one to the waiter with the order, who lays it beside the customer's plate. If the latter orders something additional the waiter takes away the first check and replaces it with another bearing the larger amount. On leaving, the customer hands the check and his money to the cashier or proprietor. This is the simplest and commonest of all methods, yet it affords scarcely any protection to the proprietor if the waiters care to be in collusion with customers, as they can easily manage to change checks or give those of less denomination than the dish ought to be sold for; in short, for a dozen reasons this plan is useless for protection, but is merely a means of expediting business by putting all the changing of money into the hands of one person, the cashier, who does nothing else. Yet, this is the only method employed in the crowded bakery lunch houses before mentioned, where the waiters carry assorted checks loose in their apron pockets and hand them out to customers as near right as they can remember to do, or as near as the checks in pocket will fit the case, for they have not time to go after more always. There the great effort of the proprietors is to prevent the customers going out without yielding up either the check or the money, and watchmen try to keep eyes on the occupants of the lunch stools as they change and move towards the door. The same free-and-easy plan suffices for the dairy lunch houses and most of the common restaurants in Chicago, and it speaks well for the honor and honesty of both customers and waiters that such an insuffi-

cient system of checking can prevail to such an extent and the proprietors not feel any appreciable loss from it. Even in the best oyster houses, where the individual bills may vary from fifty cents to five dollars or any higher sum, the method is the same and only a little more strict in the custody of the tickets, the proprietors receiving the money perhaps being able to keep a very fair run of the orders as they are served.

#### THE WRITTEN ORDER CHECK.

One of the restaurant keepers briefly alluded to in a former chapter, professed not to believe in the honor or honesty of any person where money is concerned. It may have been only his business code which he thus expressed, for some men are different when they put off their business coat and become more human. This strict man had to let the ordinary lunch business of his place run on with only the common check in use in so many places, trusting something to the tried old employés, whom he had watched for years, and much to his own keen supervision of receipts and expenditures; but in his restaurant, where the amounts of the bills were larger and the orders more complicated, he had a system of double checking, or more strictly triple checking, which was clumsy, but "it worked" to his satisfaction. He had a colored headwaiter and a white cashier—the less likely to be too friendly and in collusion against him—both having the same desk for headquarters, the cashier of course seated, the headwaiter here and there and back again. When a customer came in and ordered from the bill of fare the headwaiter wrote down his order in full with the money total added, numbered it, tore the leaf from the tab and deposited it like a ballot in a box, gave the waiter the next leaf, which was a duplicate with the same number, to place by the customer's plate, and so went on with the next order. When the customer departed he brought his check to the cashier and paid it, and the cashier dropped the check into his

ballot box. When the customer ordered something additional, an additional numbered check was given, and the same person might have four or five checks in hand instead of one. At convenient intervals the proprietor would go over the headwaiter's original checks and the cashier's currency, and if there were any discrepancies the matter could be explained while the transaction was still fresh in the mind—as it might have occurred that Mr. Such-a-number refused to pay for a certain dish or changed his order to something else. In this case the headwaiter was required to be a rapid writer and the business was only of moderate dimensions, it might not have worked so well in a crowd.

#### THE HIDDEN WATCH SYSTEM.

In many places there are various cash articles, such as cigars, drinks, fruits, confectionary, etc., sold and paid for at the same time that the meal check from the restaurant is paid, and a watch is placed over the cashier to keep tally of the things sold. Usually this is an elevated box like a pew in a church with a curtain screen, in which perhaps the proprietor's wife, or some such interested person, spends part or most of the day; the entrance being so arranged that the party handling the cash never knows when the watcher is absent, if ever. A similar watch is placed in some establishments over the order department in the kitchen.

#### THE GREAT AMERICAN RESTAURANT SYSTEM.

There is a curious though distant resemblance between the most carefully conducted English hotels and such American restaurants as are attached to the great resort hotels, in their methods of dealing with the issuance of cooked dishes to the waiters. The former keep the cooking separate from the carving and serving department. Each joint of meat or measure of cooked vegetables is weighed as it leaves the kitchen in presence of a clerk, who enters the amount in a book, and the carv-

ing and serving department is required to show what becomes of it afterwards and whether each dish returned a profit or loss. The great restaurant system is simpler. The kitchen sells each dish outright to the waiter, who must pay for what he calls for and sell it in turn to the customer in the dining room. It may be observed that the Manhattan Beach bill of fare has at the top in bold type this notice: "Guests will pay their bills to the waiters and see that the prices charged correspond with those in the bill of fare." The restaurant is already secured; the party at the table must see to it that the waiter does not impose upon him, charge him too much; bring a half portion and charge for a whole; bring a steak for one and obtain pay for a steak for two.

The proprietors of one of these crowded resort restaurants, whose customers are numbered by thousands daily, told a reporter there is positively no other way, it is the only method possible where over a hundred waiters are employed; by any other plan the waiters would manage to secure all the profits to themselves.

#### THE BOUILLONS-DUVALS SYSTEM.

The system of popular, cheap and good Parisian restaurants, world-renowned under the name of the Bouillons-Duvals, have received the most unbounded praise and also most unmitigated abuse, yet their growth and success has been so remarkable as to prove their excellence and value in spite of all detractors. The truth seems to be that they disappoint some visitors with their small portions served, their bare marble tables without tablecloths; their female waiters; a certain sort of want of style; and that is really what they are for and why they succeed—they are popular restaurants. But, whatever may be said, nobody doubts the perfect soundness of the methods employed to secure for the establishment every cent of the money it earns, without a shadow of injustice to the patron. This is the system which, it seems, ought to supersede the present crowded lunch

counters of Chicago and all other large cities. The same urgent want of a place to obtain a decent meal in the shortest time and at a small cost was felt in the great city of Paris that is experienced here, and his Duval plan proved to be the right thing at the right time. Beginning with one small soup house the Duval system has grown to a powerful company running over fifty restaurants in one city, their buying, importing, butchering and baking operations being now of as great magnitude as if all the hotels, restaurants and lunch houses of Chicago should throw their trade into one pool, all drawing from the same supply warehouses. *Bouillon-Duval* has a rather pretty look in French, but in literal English it is but Soup-Duval—we should say Soup-John's restaurant. Duval was a poor butcher who in 1854 opened a small place where he sold at first nothing but soup and beef, the Frenchman's home fare, *bouilli-et-bouillon*—boiled beef and the broth it was boiled in—but these midday lunches crowded him so that he had to move into larger quarters and, needing assistance, he found it necessary to marry a young woman who was quick at figures and had a talent for business. They increased the scope of their restaurant business somewhat and got along so fast that Duval did what so many do disastrously, he rented a fine and expensive building, furnished it "with all the modern improvements"—presumably on credit—and also with a new project of his own; a scheme for furnishing free soda water to each table and put in the necessary apparatus. But this enterprise broke him up. He came out the loser of about \$40,000. Then he began again in a small way, and his wife, looking back over what had occurred, thought she saw plainly the cause of their misfortune in the reflection that when they did a small business they could control the receipts themselves and secure all that was coming to them; when the business became so large that their employes had part control they lost. Their business increased, or, rather, their former patrons stuck to

them, and Madame Duval invented the check system which is till in use in all the Duval establishments; it is called the key-stone of the whole Duval system. After that Duval went on prospering and increasing the number of his restaurants. He died in 1870 worth over a million. He had previously converted his extensive business into a joint stock affair, himself being president of the company, and when he died his widow was appointed to the same office in his place.

One distinguishing peculiarity of the Duval system is its dealing in very small change; it does not disdain the copper cent. This might militate against its adoption in our western cities, and yet it must be remembered that the one-cent and two-cent newspapers were met at the start with the same obstacle, but overcame it. In a Duval restaurant, while a person must pay for what he orders, he needs not pay even for a slice of bread more than he wants; bread is charged for the same as anything else, and if a loaf cost four cents the customer will have to pay only 1 cent for a quarter. But this does not prevent a customer from spending as many dollars as he pleases in ordering a fine dinner with wines and extras.

Another is the employment of female waiters only. They must be respectable married women; all are dressed in a sort of uniform, which a correspondent likens to the Sisters of Charity; the reality is, however, the establishment supplies them with dresses of black or gray alpaca, white apron, tulle cap and white linen sleeves, and a silvered brooch bearing their number in plain letters. This number they are obliged to mark on the customer's ticket when taking his order. They each have to wait on sixteen chairs; work from nine in the morning until nine at night, and receive twelve dollars per month wages and two meals a day. It is supposed that most of them make about a dollar a day average, besides, from gratuities.

The Duval system of checking, upon which so much stress is laid and with

which these waitresses have much to do, consists in this: A person entering is handed a ticket from the window of the *controlleur*, a bit of pasteboard a good deal like the conductor's check showing the towns and distances on our railroads; it is a miniature bill of fare containing some sixty or seventy items with prices attached. When he has taken his seat at a table, the waitress takes his ticket and marks a charge of 1 cent for "the cover"—for the setting of the plate, knife and fork, salt and pepper and glass of water. If he wants a tablecloth instead of the bare marble, he can have one for an additional cent; if ice in his drinking water it will be one cent more, and then he goes on to order his lunch or dinner of pretty much the same dishes that are served at lunch houses and restaurants of the cheaper sort in this country. The prices are low, but the portions served are likewise small—they are such portions as our friends the drummers term samples and kick at in some of our really excellent hotels, but in either place the hungry man can order more. The Duval waiters will bring another portion and add another small charge for it to the ticket, in fact would keep on doing so all day; these restaurants sell at the cheapest rate, but do not give an ounce of anything for nothing.

The customer on departing leaves two or three cents by the side of his plate for the waitress, takes his ticket to the lady cashier who adds up the amount, takes his money, stamps the ticket and gives it back to him and he then delivers it to the controller, from whom he received it, as he passes out. A correspondent, remarking upon the various kinds of restaurants in Paris, says there is no possibility of collusion, the system is a perfect protection. In regard to a quite satisfactory dinner he took in company with a friend, he says: "We had tapioca soup, fried sole, roast beef with potatoes and c-lery, chicory salad, macaroons, and coffee, ice cream, a quart and a half of Sauterne, and a pint of champagne. The bill was exactly thirteen francs or

about \$2.47. In any other restaurant that I ever dined at the bill would certainly have been \$5, the quality of the food being the same. In New York the amount of the bill would not have paid for the wine."

It is said the total number of meals served in the combined Duval restaurants of Paris aggregate three and a half millions each year.

The most extensive firm of London restaurant keepers, Messrs. Spiers and Pond, about two or three years ago started a Duval restaurant in London, which doubtless is running yet. It was patterned after the Paris original in nearly every respect, yet there were slight modifications made to accord better with British tastes, and the prices charged were considerably higher than the original Duval's. An enterprising American hotel man, who is now the proprietor of the Hotel Bellevue, Philadelphia, a year or two ago adopted or tried to adopt the Duval system of checking, if nothing else; the result of the experiment is not known to the one writing this. It is said of the first introduction of that check system in Paris: "There was at first some difficulty in inducing the public to accept the card on entering, while many refused to give it up on leaving. Ultimately, however, good sense, firmness and courtesy triumphed, the system was securely established, and thenceforth the success of Duval was assured."

#### SPIERS AND POND'S LONDON RESTAURANTS.

The great firm of London caterers mentioned above as instituting a Duval restaurant in the English capital "on trial," in that proceeding did but give another example of the wonderful push and enterprise which has made them famous as the leading firm in the refreshment catering line of the present time, probably of any time, for the number and magnitude of their contracts have no parallel, and a history and description of their operations alone would fill a book. Messrs. Spiers and Pond (the latter recently deceased) are

Australians who went to London and commenced business in a small way. The individuality of the firm, like that of the Duval's in Paris, was merged in a stock company after awhile, and the most remarkable of their operations since have been in the line of catering for thousands at a time at expositions and celebrations. Still they have a number of restaurants in operation in various parts of the great city, the largest and perhaps the best representative of their particularly English methods is the Criterion, which a correspondent of the *Boston Advertiser* describes as follows:

"One of the unique fixtures of London, and a fixture which has nothing resembling it in any city of the United States, is the far-famed Criterion, that monster purveyor to the wants of the inner man, both fluid and solid.

"New York has her Delmonico's and Boston has her Young's; but the Criterion is not to London what these two vast eating establishments are to their respective cities. Both Young's and Delmonico's cater to the ultra-fashionable class to a greater or less extent, while that class of people in the English metropolis, when they dine publicly at all, frequent the Metropole, the Langham or the Bristol. Still, at the Criterion one finds at different times almost all classes of people, from the countryman, the business man, the howling swell, up to that class which just falls short of the 'very nobs' themselves.

"The Criterion fronts on Picadilly, Regents Circus, from which busy, noisy locality one ascends a few broad steps and finds himself in the main dining room and bar of Messrs. Spiers and Pond's sumptuous eating house. You find none of that gaudy show in decoration which is peculiar to our American bar room or dining hall. Everything about the place speaks for itself in the good, true, heavy, old English style.

"Your attention is first attracted as you enter the Criterion by the stalwart retainer, with his silver chain around his neck, ready to answer any and all questions which the new-comer might put to him, and to direct



you this way or that. On your left as you enter and at the further end of this apartment is what to the native American might be considered as the most peculiar feature of this most complete establishment.

"To the man who is accustomed to order his champagne cocktail or his gin-fizz from a row of 'bar-keepers,' clad in their spotless linen and duck, their whole make-up the very pink of perfection, the sight of eight or more fine, buxom, wholesome looking English girls behind the mahogany would probably be a novel, not to say a pleasing and interesting picture. At any rate, pleasing or displeasing, this is in store for him who visits the Criterion, and the writer believes that hundreds of visiting Americans go in there just for the purpose of feasting the eye on this array of female talent.

"These barmaids are all of them selected for their fine physique, their hair cut short, man fashion, their white collars turned down over their black gowns. They are girls of good repute, attending strictly to their business, and allowing no familiarity or freedom of speech, although a part of their stock in trade is to be possessed of pleasing and taking manners, easy flow of words, a certain knack at wholesome repartee, and other like characteristics which shall command a certain amount of custom. At this bar you will find groups of men, young and old, calling for their 'mug of bitters,' their 'thr'penny' or 'fo'penny' glass of 'cold Irish' or 'cold Scotch,' and these latter drinks are not served to the customer in the bottle, with the privilege of taking a 'bath' or anything of that sort. If you call for a 'fo'penny Irish' you get a 'fo'penny Irish' and no more. Your girl in black draws it from little wooden kegs, measuring it in a gauged measure, pouring it into the glass and setting it before you.

"There is no elaborate display of glassware. Great shining 'beer pulls' show themselves at stated intervals, and heavy decanters of sherry, port and other wines are in sight everywhere. These, together

with a goodly display of dainty bits just suited for the noon-day lunch, and not forgetting the girls behind it, go to make up the furnishing of the noted bar. Everything here is straight, no mixed drinks being served.

"Directly opposite the bar are small tables, placed in little crescent-shaped alcoves, around which are luxuriously upholstered wall seats, the very place for a cozy tete-a-tete lunch with your best friend.

"Do you wish for a mixed drink? The place for that is the American bar, in a little room leading off the main room. Here one can get American drinks served in the most approved American style. The only thing about them that might not be approved by all Americans is that the price for every drink served over this bar is one shilling; with no two-for-a-quarter transactions about them. The sherry which you pay 'fo'penny' for at the large bar is the identical sherry which you pay a shilling for at the American bar, a fact which proves that one must know the ins and outs in order to save his pence. The American bar is patronized to a considerable extent by Englishmen as well as by the nationality after whom it takes its name. This, as well as the main room, is patronized by the American colony of actors which of late have been so favorably received in London.

"Nearly opposite the further end of the bar you pass through an embossed glass door and down the easy flight of steps which lead you into the famous 'Grill Room.' Placed around this room are little tables for two, covered with snow-white cloths. Here you can order a 'chump chop,' a broiled pork sausage with broiled tomatoes, all of which dishes are specialties of the grill room. Steaks or cuts from the joints are served here in the most approved English style, and are kept nicely hot with little pewter covers for each individual plate, which fit over it to perfection. In this room the patrons are of a more solid character, with here and there the paterfamilias with his rosy-cheeked daughters

in town for a day's shopping. There is a back entrance to the grill room from Jermyn street, by means of which ladies can enter without being obliged to run the gauntlet of observing eyes in front of the bar. As you pass out of the back entrance you run across one of those omnipresent 'drop-in-a-penny' affairs, by means of which you may obtain a finely flavored Egyptian cigarette if you wish it.

"The two stories above the main room are fitted up with special rooms, set apart for different classes of dining. As you go up the stairs you meet with placards, for instance, on which you read 'Diner Parisien, 5 francs,' and on which placard is given the bill of fare for the day. On another you will see 'Dinner, 5 shillings,' together with an English menu. In this French dining room the waiters are all French and small individual tables are daintily set, each table lighted by candelabras in the evening, placed in the centre and shedding a soft and pleasant light over the room. The English dinner is such as would meet the requirements of the purely English good-liver. Other rooms are devoted to the use of private parties.

"Perhaps one of the pleasant features of the Criterion is what is known as the 'Glee Dinner.' The room where this is

given occupies almost the entire upper floor of the building, and is a very large and spacious apartment, with tables holding from four to a dozen, the whole room capable of seating 200 or more. The dinner costs you 'three and six,' with three pence additional for attendance. For this moderate sum you get soup, fish, choice of several joints, choice of several entrees, choice of several vegetables, followed by a sweet. The attractive feature, however, is the music given by a chorus of glee singers to while away the waits between the courses. On a raised platform at one end of the room is a double quartet of men and a dozen or more boys, chosen from the churches, who sing old English glees at intervals during the evening, while dinner is going on, and the music is really admirable.

"Such are a few of the many features of the Criterion. The whole establishment is over the Criterion Theatre, where Wyndham's famous company nightly delight London audiences, and which theatre is, as every one knows, entirely below the street level. In coming out of the building you find yourself once more in busy Piccadilly with its continuously passing throng, and you say to your friend, 'See you again to-morrow night in the glee room at six.'"

---

## CLUB STEWARDING AND CATERING.

---

Clubs having no "proprietor" or one who stands in the hotel landlord's place, are organized as to their eating and drinking departments in either of these two ways: The smaller clubs have a house committee which hires a steward and puts him in full charge of the culinary department, holding him accountable in monthly statements to the committee, when his books are required to show whether the kitchen is making or losing money for the club. As the club members are tacitly

expected, but not bound, to take their meals and extra suppers at the club the steward's ability as a caterer to set an attractive table often has a telling effect upon the club's prosperity.

Some of the largest and most noted clubs of the world pursue a different plan and appoint a caterer, who acts very much in the position of an independent tradesman, agreeing to furnish the meals, whether regular or private, entirely on his own responsibility, taking his own risks of sell-

ing or not selling and rendering accounts to no one but himself, being really the restaurant-keeper of the club's restaurant, with an established scale of prices and making all he can out of the club's patronage. Such a caterer has to employ inside stewards and all other employés very much the same as a hotel proprietor does, the special difference being that the caterer is usually chosen by the club on account of his being already a renowned cook, who will exercise his special function for the club's benefit, and in that respect he is far different from the mere refreshment contractors, who undertake the feeding of a multitude at so much per head. To be the steward of a club is not materially different from being steward of a first-class hotel, where a man to fill the position must be well up in party giving; in small, but expensive suppers, and he must have a knowledge of wines and liquors, more intimate and critical than the average hotel steward has any need of.

#### ABOUT CLUBS IN GENERAL.

A good deal has been said about the difficulty of filling the positions offered by club houses, and it is true that only a few men are adapted to become the abject servants which the aristocratic club idea requires them to be. There are in the largest cities healthful and useful sorts of clubs, like the Union League Club of Chicago, where business men derive real benefit from having a central place of their own in which to lunch or dine, to take a friend and pass an evening. They order from their own kitchen whatever special dishes they please, but at the same there is a regular lunch and dinner prepared by the best cooks, who are allowed the same freedom to make the bill of fare include their own best dishes and specialties that they would be accorded in any fine hotel, much to the advantage of the members, who thus benefit by whatever their employés' experience may have taught them. Some clubs in London and elsewhere have been noted for certain specialties in diet, the same as many res-

taurants, and the club members anywhere are proud of any such distinguishment.

About the "softest job" for a steward who is not over-scrupulous is to be found in the provincial club of some small town. These clubs are little more than drinking houses in disguise, probably genteel gambling houses as well. The members affect the airs of large city clubs, but are not numerous nor wealthy enough to support the pretention. For waiters they have lackeys dressed in swallow-tail coats with brass buttons, who are required to tremble when they frown, and they do frown terribly when the waiter, who has to put the suger in their tea and stir it up for them, makes the dreadful error of putting in three lumps when he ought to know they never take but two. They have a steward upon whom they rest all the cares and responsibility of running their kitchen, restaurant and liquor "cellar." They are usually in debt for their building and losing money every month besides, and, while a church society in such a case can resort to various means of raising the indebtedness, the club is too proud to do anything but suffer. But all this does not affect the steward's position or lessen its value. Only the club members are to be pitied. They are obliged to spend their money at the club restaurant and take their meals there to help it along, and obliged to buy the wines and suppers for their friends there, although the fact of the club's being in debt is excuse enough for everything being charged for higher than would be the case at Delmonico's in New York. But "they that dance must pay the fiddler;" the steward who finds himself in such a position must expect frequent changes to occur and must do the best he can. As the club system combines, at least in the case of business men's clubs, both the *table d'hote* or hotel plan for regular club boarders and the restaurant or private party plan, an intimate knowledge of both is required by the club steward and a special readiness to tell how much such a meal will cost for how many.

## PARTY CATERING.

The tendency to choose the principal hotels of a city as the place to give party spreads as well as public banquets is on the increase, and it is now the case that in some of the largest there is scarcely a night in the week during the winter season that one or several such entertainments do not take place, and it has come to be a part of the hotel business and is provided for with special dining halls and all proper catering appliances to a great extent independent of the regular daily business. Where such arrangements are made for the purpose, the probabilities of the little supper or the fashionable reception or grand banquet being served in a satisfactory manner are much greater than when it is ordered from some professed caterer's independent establishment, the latter having to contend with the scarcely surmountable difficulties of transporting the prepared food and refreshments in wagons through the streets to their destination with all the shaking up, mixing and disarrangements attending such an operation. The experienced caterer is always seeking means and appliances to prevent such damage, and the successful men are those who accomplish most in the way of prevention. However, the hotel has immense advantages in that respect.

The stewards in such cases are called upon to meet requirements as widely different as can be imagined; the character of the entertainments running through all stages from the most economically planned charitable affairs to the most elaborate and costly complimentary banquets, and nothing is more common than for two just such extremes to meet on the same night in the same hotel. While I propose to give some examples of actual spreads with the amounts of provisions consumed and the cost, I will say plainly that they are far less likely to help the inexperienced steward than will be the learning of a few fundamental rules, which I have found so useful myself as to regard them as infallible.

I will name them in order and also note the exceptions and occasional disappointments, which are in the nature of accidents which nobody can entirely guard against. But first as to

## MISTAKES IN ENTERTAINING.

We can never find out from the published reports in the newspapers whether an entertainment tendered for some specific purpose was satisfactory to those entertained or not, particularly if the good name of the town is involved, it is the papers' business to say the pleasant things and leave the unpleasant unsaid, and common politeness compels the guests if disappointed to keep their thoughts to themselves, or at least among themselves, and so we can go on committing the same blunders over again. I venture to think that grave mistakes are being made constantly when complimentary dinners and suppers are tendered through the hotel trying to "show off" too much, at the expense of the enjoyment of the people entertained. As caterers, stewards and cooks we are not always responsible for this, for those who order must have style at whatever sacrifice, but as we are often consulted and frequently given entire control I will show what seems to me to be mistakes by two or three instances.

An excursion party of prominent men from a distant state, numbering about twenty, went to a noted summer hotel upon invitation of the proprietors in the height of the season and arrived just as dinner was beginning. If the real enjoyment of these guests and enduring pleasant memories of the visit had been the chief thought and object of the entertainers, they would have been delayed half an hour, perhaps an hour, and then conducted to the best tables, given good waiters and the very same bill of fare which the hundred or two of gaily-dressed, summer-enjoying regular guests were deriving pleasant satisfaction from; they would have chosen as they pleased, had sociable surroundings, could have finished dinner in an hour and

made to feel at home. The only man consulted about it chose differently, however, and thought nothing would do justice to the occasion but a dinner in about ten courses, and as it was neither advisable nor practicable to cook a fresh dinner some portion of the regular dinner—already old—was saved. The guests were kept waiting for two hours after arrival, a special long table was set lonesomely enough in a corner of the great dining room and the tedious course dinner doled into the poor fellows through two weary hours, they being forced to sit and submit for politeness' sake, although before they got through the other watch of waiters was buzzing around them preparing the tables for the next grand meal. The published resolutions of thanks in the papers next day were all right, yet I don't believe they enjoyed the visit or the dinner or would consent to go through it all again, and don't think that was the way they should have been treated. What did they care whether that particular headwaiter knew how to serve dinners in courses or not? They were on a summer pleasure trip and wanted summer fare and lightsomeness.

A similar affair occurred in another place where the guests—also an excursion party present by invitation—did express their impatience with a too tedious banquet and arose and left it unfinished. They were well-known capitalists, about seventy in the party, and had been feasted, receptioned and banqueted to the limit of endurance and came to this place at night tired. The proprietors, just retiring from the business, seized the opportunity to make a parting display and, instead of the informal little reception at first intended, spread themselves out and made a really elaborate and expensive banquet in ten courses. The guests intended to be honored sat down and managed to contain their impatience while course after course was rushed in with all possible expedition until they had endured nearly two hours of it, when they incontinently rose, locked the doors that led in from the kitchen, marched out

of the front doors and went to bed, leaving the remaining one third of the luxuries for whom it might concern. And they did just right.

The next instance of overdoing was not stamped a mistake in any such emphatic way, and the local papers were good enough to apply their choicest terms of praise after it was over, yet I have it among my foremost examples of blunders in this line. About 200 Knights, of no matter what order, from a western city were to be entertained by the local lodge of a country town acting as a committee for the town, the citizens at large having subscribed to defray the expenses. They let the job to a caterer for a set sum and left everything to his discretion, only evincing an excusable anxiety to have the affair redound to the credit of the town. Two or three assistants were set to work and decorated dishes "*sur socle*," and tall cakes were prepared and a stylish sort of menu for a hot supper prepared, with green turtle soup in the foreground and oysters occupying a rather modest place in the rear. The supper passed off successfully and, as already said, received plenty of newspaper praise. The grand mistake consisted in not making it a grand fried oyster supper, as the event showed, for the green turtle soup, so far from being appreciated as a luxury in that far western country, was absolutely not even called for while the oysters in every style could not be served fast enough by all the hands available. The line of reasoning had been that oysters were too common to make a fine entertainment even there, for oysters in bulk frozen were plentiful and every little party and every sort of festival had been serving oysters till there was nothing so common. It made no difference, however, the 200 wanted oysters and cared for nothing else. The supplies had been laid in so judiciously that fried oysters could be and were served half a dozen to each person, and stewed oysters without limit, so there was no misfortune. What was wanted to make that the most memorable feast those Knights

and ladies had ever attended was a plate of a dozen double-breaded large oysters, properly garnished in Chicago oyster house style, with more in reserve if the dozen did not suffice, and two-thirds of the rest of the banquet might have been left unmade, and one day's work of preparation would have made more real success than the three days and nights that were really consumed in it.

#### RULES FOR PARTY CATERING.

1. Never, if possible to avoid it, agree to furnish refreshments for a party without having the committee to bind itself to pay for some certain number whether they come or not. Four times out of five where it is a pay party there will be fewer people in attendance than were expected, and the hotel keeper or caterer who agrees for so much per head has to lose all that he has prepared in excess, when it sometimes is the case that not more than a fourth of those provided for ever come. It is made the worse for the caterer because the members of the committee are apt to become excited over prospective numbers and induce the provider of the feast at his own risk to provide excessive amounts; if on their own risk they will be more cautious. A few months previous to this writing a hotel manager was applied to to furnish dinner on a stated day for 500 locomotive engineers on their annual celebration, and acting on advice, the same as above laid down, obtained a contract for 500 dinners at a dollar a head. The hotel was already crowded, but by an effort, such as hotel people can make when they try themselves, the extra 500 dinners were prepared and the crowd arrived on time, but only 360 came, and they were well entertained. There was, of course, a surplus left over of about 140 dinners, but the hotel manager having his contract all right got his pay for them and was so much ahead. In too many cases the result is different; the hotel man takes the risk, loses the 140 meals and thereby loses all his profits on the transaction and works for nothing.

When it is a free or complimentary feast, the proper way is to contract for the probable number and agree to feed all above that number at a certain price per head.

2. When agreeing to furnish refreshments bear in mind that the number agreed for does not represent all; there will be musicians, drivers, attendants, press representatives, and various "complimentaries" not counted by the committee; calculations must be made for these, especially in an expensive spread, and the price made accordingly. It may be a quail or terrapin supper, where it will not be practicable to make distinctions among those who eat and twenty, thirty or forty "complimentaries" may consume all the profits if the caterer allows his estimate and contract to run within too narrow margins, particularly when the affair is but thinly attended.

3. If your hotel waiters, cooks, pantry-men, dishwashers and others do the extra work of a party without extra cost to you, that is no affair of the party-givers, the prices charged ought to cover the extra work done by the hands. All other trades and professions charge their customers for the labor of their employés, and charge a profit upon that labor besides, and there is no reason why hotel keepers should do differently.

4. Never, unless for very special reasons, agree to furnish refreshments "just for the fun of the thing," imagining that as the hotel is already running it will not really cost anything. Such extra spreads disarrange your store-room keeper's accounts and make extra book-keeping; they make tired help and poor meals and poor service for the hotel next day, perhaps for several days, and great incidental waste and expenses which the proprietor scarcely knows of except in the final reckoning. The very special reasons noted may be the necessity of advertising a new hotel; a sort of throwing bread upon the waters. The bread costs something, perhaps a good deal, nevertheless.

While the foregoing rules are principally directed to hotel-keepers, the next is a most valuable guide to every sort of caterer and

provider of meals, and ought to be kept in memory. The worst feature of hotel party-giving is the large excess of provisions always prepared and left over; the preparing of twice as much as will be needed. The fear that there may not be enough is the reason of this superabundance, when feasts are prepared without any basis of calculation, yet it is easy to know in advance how much will be consumed by any given number.

5. One hundred people at a party will eat one hundred pounds of food and drink one hundred pints of fluids.

That is, each person on an average eats a pound and drinks a pint.

One hundred women eat less than the same number of men — many men eat much more than a pound, but in a mixed gathering the average remains as stated.

6. To furnish one hundred pounds of cooked meat, it is necessary to buy two hundred pounds, because meats in an average way lose half their weight in cooking and trimming. Chickens and turkeys lose more than half their raw weight, hams and tongues lose less; fresh meats and fish just about half; consequently the calculation of two hundred pounds of raw meats, poultry and fish for one hundred persons is near enough for the average and is a rule easy to remember.

7. As each person at a party will eat a pound of *something*, where cheapness is demanded the feast should be made up as much as possible of things made of flour, sugar and, sometimes, eggs. A supper of all sorts of fancy yeast-raised cakes with lemonade or ice cream can be furnished for a few cents per head, while nothing in the meat line can be served for less than fifty cents and upwards,—to serve only one-half of a canvas-back duck to each person may cost one dollar per head for that one item alone.

8. Allow one quail for each person and one-third more as a reserve for repeated orders at a quail supper or breakfast, but half a quail is enough for each person at a course dinner, when quail forms the game

course. Smaller birds such as snipe can not be divided. Spring chickens should be calculated to serve half a chicken to each person, but a good deal depends upon their sizes and upon the consideration whether chicken is to be the leading dish of the meal or only a part of a dinner of many courses.

9. To know how much of each kind of meat, game or fish will be required in an ample feast calculate that each person eats two ounces of each kind—a cut of beef or ham weighs about two ounces, a quarter of a young chicken about two ounces, an ordinary helping of fish about two ounces, sandwiches weigh one or two ounces each according to the thinness of the bread. Eight different kinds of food served in two-ounce portions will make up the pound that fills the capacity of the human stomach for solids.

10. Guard against disaster by being well fortified with a reserve of ice cream and cake, cold chicken or turkey and ham sandwiches. The feast may be all consumed, the dinner or supper over, but if these things remain all the late arrivals can be made happy.

11. In some cases, such as winter excursion parties, the one thing of paramount importance is hot coffee and means of getting it served in short order. In all cases the coffee is the first consideration. Provide three-fourths of a pint—that is two cups—for each person expected, or nine gallons for a hundred people. This will require four and a half pounds of ground coffee or a pound for two gallons of ordinary coffee, but for strong coffee for a regular dinner a pound to one gallon is required and less than half the quantity of coffee is wanted by each person than is necessary to provide for an excursion.

12. For an oyster supper calculate a pint of soup or stew for each person, made up of one-half oysters (raw measure) and one half milk. As both oysters in bulk and milk are bought by the gallon this is an easy calculation, it is twelve gallons for one hundred persons of which six gallons

are bulk oysters and six gallons milk. But the oysters yield a large amount of liquor in cooking, and when the stews are made in these proportions the result will be only one-third or even one-fourth of *cooked* oysters in a bowl of oyster stew.

13. Large and choice oysters for frying are bought by the hundred. A dozen will fill an ordinary coffee cup. A dozen is a portion for an oyster supper; four to six for each person are plenty for a hotel breakfast. When oysters form part of a course dinner four to six for each person are enough; that will be a cupful of selects for three persons, or four or five gallons of large oysters for a hundred persons. It will readily be understood that there is a great difference between the requirements of the boarders at a hotel table, where oysters are served as commonly as beef or bread, and a party supper where the people come especially to eat oysters.

14. Dinners served in courses require the preparation of greater quantities than for ordinary meals or party suppers, for two reasons: first, although all persons do not eat the same things and some will eat the relishes or vegetables and not touch the fish or meat that is set before them, yet it is necessary to place upon the table enough for every one of each separate course, and some of the dishes may be returned to the kitchen scarcely touched; and, second, the usual long duration of course dinners, being anywhere from one to three hours, allows the stomach to become partially emptied of the first sustenance and enables people to actually eat more at a sitting than the average sufficiency. They sit and perhaps sip stimulants until they almost become hungry again, and the caterer may as well make his calculations double for such occasions and his charges according. However, nature will assert itself at last and the caterer gets even who has to furnish a few succeeding meals to the same persons.

#### SOME EXCEPTIONS.

And now, having penned down the foregoing rules which experience has shown

me are reliable guides to base calculations upon—most especially the pound-to-a-person rule, the pint-of-fluids rule and the two-ounce-portion rule,—I am obliged to talk over some exceptional cases, for fear some unguarded young business man may be led into trouble through placing a too implicit faith in people. Our calculations are made for the class of people one expects to meet at a genteel party gathering and for well-fed and discriminating hotel boarders, who do not generally fast a whole day beforehand to make ready to gorge themselves at the caterer's spread at night. It is a good many years ago, though I remember it as if yesterday, a young fellow recently started in the restaurant and baking business, came to me at the hotel where I was employed and said he had just been offered the contract to furnish supper for 200 at fifty cents per head; should he take it? The occasion was a cheap ball at a dollar a head including supper, to take place in a public hall. Being like all new beginners, anxious to secure a run of business, he concluded he would and asked me to help him with his calculations. I had no rules to work by then, but we argued that as the hotels could furnish such a good and abundant dinner as they do for fifty cents, there must certainly be a good profit to be made out of a cold supper at the same price, no very elaborate work being demanded nor anything particularly expensive. Then we sized up the amount of dinner that would be needed in a hotel for 200, and he proceeded on that basis and made ready for the night. But a terrible night he had of it. He set his pretty tables as a young fellow will, with whole chickens, hams and tongues decorated, expecting his assistants to carve them and serve everybody as orderly as in a hotel, but he did not know the people he had to feed. They had evidently been starving themselves for the purpose of making a gorgeous feast out of this fifty-cent banquet; they waited for nothing, but after three minutes of wild clamor they went for the tables. One seized a whole ham on its dish



and took it to the corner where his family sat; another took a dish of chickens; another, finding no meat, took a whole cake, another a pyramid of something else; in about eight minutes there was not a morsel of anything left on the tables, a few little bunches of people had secured everything and the majority really had nothing.

There is a warning and a lesson for beginners in that, the meats should all have been cut up beforehand and many hundreds of sandwiches prepared; whether sliced meats, sandwiches, bread, oysters or cake, everything should have been in small portions upon hundreds of plates, so that the people should all have fared alike whether they got what they wanted or not, and the provisions should have been served from behind a barrier—like a table set a few feet back covered with plates of supper with another table in front as a counter to serve from—or else out of small windows.

But to resume: my young friend was then in serious trouble, his supper was all gone, yet very few had been fed and a riot was beginning. He got some of the big bugs of the crowd to spread the word that he had plenty more in his bakery and would have it brought up immediately. Then he took all his assistants and brought up everything eatable that his restaurant and bakery contained, beginning with cold meats, canned goods, boiled eggs, taking every pie and cake and loaf of bread and at last giving up his boxes of crackers, raisins and candies. And still the people were unappeased, and scores of them declared they had not got a morsel to eat yet. There is no doubt but a good deal of stuff was pocketed; then some were beginning to see there was lots of fun in this thing, particularly those who had secured lion's shares of whole dishes and were laughing at the others, and some, perhaps half drunk, were hiding and withholding eatables out of pure devilment. But my young friend still continued his efforts to satisfy them all; he was anxious about his reputation and also feared that the committee might try to withhold the pay if he did not

fulfill his part of the contract to furnish suppers for all; then he came to me, there being no place open to buy at after midnight, and we persuaded a good-natured hotel-keeper to sell him all the bread and cooked meat there was in the house, and with that relay and the impatience of the company to go on with the dance, the trouble was tided over. The young man got his pay from the committee without trouble, and all but a few of those present thought the affair was a fine joke after it was over. Of course the caterer lost money, far beyond what he had hoped to gain in profits, and was badly scared. As this recital is but supplementary to the rules above, I must add here some maxims not less important. Cooking and service go together. A pound to a person is sufficient, but you must see that each person gets his dues. If one person gets away with four portions the other three may raise a riot and be in the right, although you have done your part in one respect. The getting of each portion to each person is the art of service. The art of providing and cooking is only half, service is the other half, without which the first is useless.

The other instances which I intended to relate were of private receptions, where the youthful guests—perfect bunches of flowers to look at—acted astonishingly; but on second thought I have concluded to say nothing about them, but leave the circumstances to the readers' imagination, for really all of us who cook and cater have a sort of secret love of the hearty eaters, and these young people of the very good society of very good cities are quite excusable for going without their home suppers and even their home dinners in order to be ready to do full justice to all the good things we make for them. They live frugally at home, as they must for the sake of their healthy growth, and the beautiful simple hygienic foods which they grow so lovely upon are still rather insipid and tasteless. They come to our parties and every mouthful they try has a new rich-

ness, every morsel has some exquisite and unwonted flavor and they cannot resist, they must eat and ask for more, they can not help it, even though the astonished hostess who has invited them has to go to bed with a sick headache in consequence, and the young and unsophisticated caterer becomes old and gray-haired through the terrible experience of a single night. I would not even have alluded to these things but for the purpose of saying the caterer, whoever he or she may be—for many ladies are now engaged in the business of furnishing refreshments to order to "society" people's entertainments—shou'd fortify themselves by having a reserve of something plain and common, a quart or gallon of the thinnest ice cream unflavored, a lot of stale cake, something like sponge cake two weeks old, or heavy pound cake to taper off these abused feasts with. The grown people, the appreciative people, all take their sufficiency of the delicacies and there is an end as far as they are concerned, and the others, hollow young boys and girls who cannot stop, have to be weaned and choked off with something common.

#### BALL SUPPERS.

It is so commonly the case that the dance and the supper both have to take place in the one room, the hotel dining room, because there is not a second room large enough, that, in offering these suggestions, I shall always have to consider that the likeliest contingency; yet it is by no means the best or pleasantest way to carry out such affairs. The best of all such parties that I can call to mind have been those where there was a ball room separate from the supper room, where the latter might be prepared in a leisurely manner, decorated, set with the best skill of the best table men, made to look handsome, and at the appointed moment the doors were thrown open and the guests marched in. Some pleasantly arranged hotels have a parlor so large that it serves the purpose of a ball room in ordinary times, that is for everything but grand

balls attended by large numbers, and a little forethought exercised by the builders of hotels might generally lead to the grand parlor and ladies' ordinary, or the reading room or some other adjoining, being fitted with sliding or removable doors, all to be thrown into one ball room without interfering with the main dining hall at all. The city halls which caterers serve entertainments in are so arranged as to have separate dancing and supper rooms, else they are not fit for the purpose, and the caterer who finds the hall not so fitted should think twice before he undertakes the job, for supper-giving becomes a more complicated and troublesome affair when the dancers have to be asked to please stop while the tables are set in the same room, and again while they are cleared away.

#### HOW TO SET THE TABLES—SMALL TABLES.

The most entirely satisfactory way of setting out a ball supper, if the pleasure of the participants is to be the main object, is the setting of the small separate tables the same as they are at dinner, although there may be something grander and more imposing in the sight of two or three long tables the whole length of the hall. Your small tables are for six or eight seats each; the people sit around them, sociably, comfortably, and have the proprietorship of the one waiter, who knows his station and cannot be called away. Supposing there are twenty tables, the requirement is that each table be set alike with cold dishes in advance of the meal, with plates, silver and napkins as for dinner; the people march in when the signal is given, take their places in groups at their favorite tables and help themselves to the supper already before them, the waiters being to pass dishes from one end to the other, to bring in the ices and coffee at the right time and replenish any dish that may be insufficient in the first setting.

#### WHAT TO SET UPON THEM.

There should be a center piece of flowers or ferns or something ornamental. The

ordinary cruet stands are not admissible, but small novelties in china, silver or glass for the purpose of holding the three or four common seasonings may be found in some inconspicuous position, and silver sugar bowls newly filled, likewise. On each side of the center piece set one decorated dish or bowl of salad, one decorated dish of meat, and a small pyramid of neatly shaped sandwiches piled upon a handsomely folded napkin. The two salads upon each table to be of different kinds, the two dishes of decorated meats different, the sandwiches different.

Besides these there must be plates of bread or beaten biscuits, olives, pickles or cress. The waiter in attendance at each table observes and when the time to remove the dishes has arrived he immediately replaces the empty meat dishes with ornamented baskets of assorted cakes and bon-bons and choice fruit, which he has already brought in upon his large tray and kept upon his sideboard or stand-table; he then changes the plates and at once proceeds to bring in the ices and jellies, moulded and turned out upon a dish raised in the middle and covered with a fancy folded napkin (or dish inverted in a larger dish and covered with the napkin), and lastly, brings in the coffee in small cups, an individual silver pitcher of cream along with each cup.

#### WHAT MAKES THE DIFFERENCE IN COST OF SUPPERS.

Referring to the foregoing as a sample, I will offer a little information now to the committees who come proposing "a nice pleasant social hop, you know, and a little plain refreshments—we don't want much, but want it decently served, rather elegant, you know, but nothing costly—we have been thinking we ought to have a couple of salads, two or three kinds of cold meats or sandwiches or both, and a little cake and ice cream to finish off with—that won't be much trouble, will it? Now, what will it cost us? How low can it be done?"

"Well, sirs, I am sorry to say a little

plain pleasure should cost so much, but that little supper will cost you two dollars a head, four dollars a couple."

"Oh, nonsense," says committee impatiently, "the tickets to the ball including supper and everything are only five dollars a couple, and you would leave only one dollar for all the remaining expenses?"

"Well, as you have not specified what the particular meats and salads and creams are to be, we will retrench a little and put it down at a dollar and a half a head, but there is no inducement in it at that price."

"That is altogether too high yet," says committee, "what, for a little cold meat, salad, ice cream and cake a dollar and a half apiece! We can go to your best hotel and have the best dinner they can get up any day for a dollar, and here you want for a plain—"

"Wait, gentlemen, let me tell you how that is, you can have the supper for a dollar a head if you have it as plain and scanty as your words would describe it. It was your putting in the little words *elegant* and *decently served* that raised it to two dollars, for those expressions imply decoration, skilled labor, extra-paid over-time, trained waiters and plenty of them, good table ware and plenty of it, and choice viands instead of cheap ones. There is no meaning in 'a little ice cream and cake,' for there must be enough in quantity or none, but plain cake and plain ice cream you can have cheap enough; if you run to varieties of molded ices, jellies and macaroons it takes up much time of skilled hands with several assistants, and thus the expense grows the same as with the mea's."

#### QUANTITIES AND QUALITIES.

If you have the roast-cook to plain-roast 40 chickens for part of the supper of the 150 or 160 persons, who will be seated at the 20 eight-seat tables before mentioned, and when the chickens have become cold have some careful but ordinary helper to cut them up and place the pieces into 20 dishes, one for each table; it is a plain and simple matter of small expense. But if,

after the chickens become cold, the meat must be pulled from the bones and freed from skin, then be cut, not hashed, and added to a similar lot of celery, and there must be made by a skillful cook from two to four quarts of mayonaise dressing for it, consuming, before the salad is complete, about a gallon of fine olive oil, the chicken begins to be expensive. If then it is to be kept in a pan or large platter and dished out by spoonfuls it is still not very dear nor at all elegant. But if on the contrary, it is to be shaped in a suitable mould, turned out into 20 dishes, one for each table and all alike, and then spread over with the dressing skillfully, decorated with perhaps a dollars worth of capers, a similar value in olives, and as many quartered eggs, the 40 original roast chickens have become "elegant," but also expensive, and that not so much owing to the materials as to the tediousness of all the operations, occupying for several hours one or two skilled hands and some assistants, and the little salad is but one-eighth or, likelier, one-twelfth of all the dishes to be made.

The 40 plates of sandwiches which are part of the sample supper previously detailed—two plates to a table, the kinds being different, may be equally plain, mere sliced bread and meat; or may consume hours in their preparation, as when made of grated tongue, minced ham, sardines, anchovy butter and veal or chopped pickled oysters and butter, and the various combinations, the bread having to be very thin and cut to symmetrical shapes all of one size and appearance. The most tedious are rolled sandwiches, each one having to be tied with a ribbon and the more troublesome when the bread is of a contrary nature, too brittle to roll easily.

To mould the charlottes and jellies, whether in 160 individual moulds or whether in 40 moulds—two for each table—is another time-consuming operation and requires room in the refrigerators to set them, which is often very hard to find; whereas if only to be "spooned out" they may be kept easily in a tub of ice-water and

served cheaply. To mould ice creams and turn them out successfully requires skilled workmen instead of helpers from first to last, and doubles or more than doubles their cost.

These examples should serve to explain why the very same eatables can either be served at a profit for one dollar or served at a less profit for two dollars. I have no inclination to pursue the subject to the point of tediousness, but it remains to say that a cheap supper must be attended by but half as many waiters or even one third as many. All of the dishes, both meats and sweets, can be put upon the tables at once and the guests left almost entirely to help themselves, and instead of making two courses or "services" of it all the few waiters have to do is to begin to bring in the plain saucers of ice cream as soon as they can in order to get all served without any having to wait. For it is to be remembered always that a ball supper is only an incident of the ball, an interval in the dancing, which many people wish to make short and not lose much time over; it is not the principal object in the meeting and haste in serving it is always excusable.

#### WHAT DECORATED MEAT DISHES CONSIST OF.

The 40 decorated cold meat dishes named for our sample ball supper may consist of anything in cold meats which is named in any of the bills of fare to be found in these pages; but, to be explicit, the plainly cut up roast chicken already instanced may be arranged in neat shape in the dishes and bordered with water-cress or garden cress, or, rather, the cress should be placed in the dish first and chicken upon it. The cress is a good relish to eat with the chicken, but if none to be had then border with parsley, and it becomes a decorated meat dish. To do better than that, the breasts only of the chickens should be cut in thin slices, without bones, trimmed a little to make them nearly of one shape and size, laid in order in the dish and bordered with green and with sliced lemons.

Next above that may be instanced breast of chicken (or turkey) decorated with jelly, the jelly chopped, put into a paper cornet and pressed out of the point in piping the same as in icing cakes, also, the jelly in any kind of fancy shapes placed with a knife. Next may be smoked tongue thinly sliced and decorated in the dishes or, commoner, red corned tongue. There are such dishes as white veal cut into round pieces like silver dollars, two pieces together with grated tongue between and a spot of jelly on top, cold oyster pies or patties or similar patties and vol-au-vents filled with finely cut game or chicken in a sauce, cold but rich and as firm as jelly. There are boned chickens and galantines of various things which are in effect, ornamental and spicy-flavored rolls of boneless meat, very handy to slice and savory eating, and among the most expensive decorated cold meat dishes may be named boned quail and other birds in aspic jelly and stuffed or decorated with truffles and plovers' eggs. It is the tediousness, trouble and elaborateness of these things which makes most of the difference between one-dollar and two-dollar suppers, and the addition of wine that makes the difference between five dollars and ten.

#### WHAT THE ORNAMENTAL BASKETS OF CAKE CONTAIN.

As far as the giving an inviting appearance to the tables is concerned the baskets or stands of cut cake have quite as good an effect as elaborately ornamented cakes, provided the cut cakes are made suitable for the purpose. Ordinary slices of cakes baked in deep moulds cannot be made much of, they are slices of cakes and nothing more. Bake cakes of different sorts in thin sheets, differently flavored and of different tints and textures. Place some of the sheets two together with jam and jelly between, and leave some as they are. Take a bowl of fine powdered sugar and wet it either with wine, with bright-colored fruit syrups, with yolk of eggs for yellow, with chocolate syrup or with plain water;

for each sheet of cake make this plain sugar coating a different flavor, make the wet sugar so thick that it will just barely settle down smooth and glossy when poured on the sheets of cake, and ice over the top of every sheet so prepared, except one for plain cake for those who prefer it. Besides the plain white, chocolate and yellow, the fruit syrup will have made a red or pink sheet, if not, color one bowl of wet sugar. It needs no beating, this kind of icing, and will dry on the sheets of cake in an hour. To further increase the variety, chop some of the greenest citron and sprinkle it over a white sheet while still wet, do the same for a pink sheet. Take some grated fresh cocoanut, clean and free from specks and strew it over one or two other sheets while still fresh-iced and wet, and scatter split almonds or walnuts over another. To make another kind mix grated or scraped almond paste with the sugar and spread that upon a sheet or between two sheets. Let the flavors be various; almond, pineapple, orange, vanilla, banana, lemon, anise, peppermint, peach.

These broad sheets of cake having been prepared, the next thing ornamental is to cut them carefully and the special recommendation of this plain sugar-and-water icing is that it will not break, but can be cut into any fancy shape that the cake will bear. Cut some of the sheets into crescents with a biscuit cutter, cut some in diamonds, some in squares. Now bring alongside an assorted lot of macaroons, egg kisses, solid kisses, hollow kisses, or *meringues à la crème* baked on boards; chocolate meringues, rose meringues, and stars and fingers, and covering the basket with a handsomely folded napkin you can stack up a pyramid of assorted cakes that will be more immediately attractive and give more satisfaction than an elaborate'y ornamented cake on which two to three days' work has been put could do, and these assortments, fortunately, are not particularly tedious to make, if we except the meringues in large quantities. In addition, or for a change from these, there are the

jelly rolls, variously iced and colored and coated with almonds or fresh cocoanut before slicing; there are the various sponge drops and fingers, wafers and curled snaps and small cakes iced with chocolate and piped with white.

But in the more elaborately set table the one basket of this sort will be matched on the other side by a whole cake with some light and fragile kind of ornamentation raised upon it, but this cake under present fashions must be cut, if only one section taken out, to invite immediate use. It must be of little weight, shallow in the mould, regularly iced with white-of-egg icing and beautifully bordered and flowered, besides the raised ornamentation, and forms the pastry cook's offset and competitor to the meat cooks' decorated galantine.

#### WHAT THE MOULDED ICES AND JELLIES ARE.

It is a pity to have to say what they are, for the grand endeavor of caterers both public and private is to get something new in this line to beat somebody else. There is an effort to make new effects in the meat line, but that is more difficult; but when it comes to the sweets it is thought they are like toys, only passing fancies, and may be used to further any fantastic notions that ingenious people may adopt. However, as this might seem a formidable task to have to invent a new device for every ball supper or other party, it is encouraging to remember that every old invention is new in any place where it has never been seen before, and the fancy form of ice which may have been served up to the queen of Sweden thirty years ago is still a charming novelty in almost any town or city where the caterers have not been too enterprising already. All the cook books and all the confectionary books therefore will furnish notions for something beyond plain ice cream. There is the brick of ice cream in three colors to be sliced, that is the panachee or Neapolitan; the brick or mould of any kind having an outside coat of one color, the inside filled with a different kind;

that is the *bombe*. The plain yellow ice cream may be pinched up between a pair of pewter moulds hinged together (or first dipped in water), and the ice cream drops out when they are opened in the likeness of a peeled banana. Another pair of moulds makes a pear or a peach, a little pink ice being placed in the mould to make the blush; another pair makes an egg, another a stalk of asparagus, with some green pistachio nut ice in the end to make the head. These moulds, dipped in water after each form is made, will form the ice cream out of the large freezer as fast as they can be carried in by the waiters, if three or four hands be employed at it at once.

To give an idea of what the caterers do in the city society circles, where nothing whatever is new and the party givers have a great repugnance to repeating what some society rival has already done, the following extracts from correspondents' letters will prove useful.

It has to be said further in praise of the small tables for party suppers that they admit of the adoption of all the new devices of private parties, it being only necessary to multiply them, one for each of twenty or forty tables—itsself an achievement worthy the ambition of any hotel manager or caterer; and, besides, the room full of small tables, and they fully occupied by people in full dress, makes just such a scene as only the finest appointed restaurants in the world can equal during their best hours. But to our extracted paragraphs:

“The desire of the fashionable world for some new things lead them into queer freaks now and then. One of the queerest, and to my mind the nastiest, is the latest form in which ices are served. Last year the favorite method of serving them was pretty and picturesque, consisting of little plated silver candlesticks. These contained a colored ice frozen in the form of a fancy candle. In the top of this was thrust a wax taper to be lit just before serving, and the whole crowned with a tiny silk shade. When they were served with the tapers

lit the effect was extremely pretty, and, after admiring it, one pulled off the shade, extinguished the taper and proceeded, like the Esquimaux, to lunch upon candles.

"But this year the very latest Parisian idea is to serve the ices in the shape of a family washtub, filled to the brim with meringue in imitation of soap suds, and in these white masses one is permitted to fish at random to bring up whatsoever piece of the family wash fate or luck assigns one. To some fell a stocking in pink ice, another gets a cuff or a collar, or a square that is supposed to represent a handkerchief. The whole idea is revolting, and, strange to say, has been very popular. Much more charming were the ices at a luncheon given by the Misses Furniss the other day to thirty young women, where, it being a "hen party," the ices appeared in the shape of a big motherly hen sitting in a nest of spun sugar surrounded by eggs of vari-colored ices.

"The most novel dinner device of which I have heard recently was a mould of wine jelly in the midst of which was set an electric light. The dish had to be arranged on the table beforehand, but it was concealed by a big silver cover, which was in turn hidden by flowers so as to form a centre piece to the table. When the cover was removed and the jelly, with its cluster of red and golden and purple fires, was disclosed, the effect was quite tremendous. One lady, it is true, asked her escort if he didn't suppose the jelly would taste electrical, and another in eating it declared she felt as if she were swallowing a Leyden jar; but the device was really very pretty, as well as novel and striking."



And here is a pretty fancy, which words would be insufficient to describe, orange

peel baskets filled with jelly. One such dish for each of our 20 tables would be about right. There are eight of them, just enough to go around.

#### SETTING LONG TABLES.

These small tables may be placed end to end to make two long tables down the hall, but in locating them it is necessary to ascertain by actual trial whether after placing the two rows of chairs there will be room between them for the waiters to pass along freely, if not some other form of arrangement may be necessary, as sometimes there is a long table and another across the end in the form of a T. And to save waiters and make expeditious service in such a hall, there are often side stands or tables set with some of the dishes or having the ice cream behind them as behind a counter, all so near the main tables that the work of handing over is but very slight.

The long tables are the more imposing, and are always to be preferred when speech-making is to follow the supper or dinner, for the obvious reason that the company already faces the speaker either from the right or left without moving the chairs.

The tables are set according to the occasion; for a grand banquet they are decorated with tall designs in flowers, which it is the florists' special business to furnish, and at times with statuettes, if possible emblematical of the cause of the gathering, and at such times great use is found for the confectioners' images modelled in sugar, and significant designs even in pyramids of meat. For the less formal ball supper, the tables being decorated with flowers and foliage according to the changing fashions, which may call for loosely trailing vines, mats of moss and scattered roses or violets this year and tall vases of flowers only next year, may still be much enriched by small stands of decorated meats, baskets of cake and ornamented cakes, precisely as for the small tables already described in detail. It is only re-

quired that these stands of handsomely prepared eatables shall be of but a secondary prominence, not so large or so numerous as to make the tables look like a candy stand at a fair. They are to be to a well set table what statuary is in a grove, or like bunches of ready-ripe fruit in a late orchard.

One waiter to every ten chairs is the requirement for this style of table, and if an oyster supper, or partly hot and partly cold meal, as the people all come in at once and expect instant service, the oysters should be placed at each place at the minute before the doors are thrown open, and the bulk of the supper being already on the table the waiters have little to do except pass the dishes within reach until the time comes for the ices and sweets.

#### WHERE THEY DANCE IN THE DINING ROOM.

That is all very fine and easy of accomplishment where there is a ball room as well as a dining room and where the setting of the tables and furnishing them with new and startling effects may begin three or four hours or even a day before the banquet, but where, as in thousands of hotels, there is but the one room large enough a different line of management has to be pursued.

#### THE STAND-UP SUPPER.

It is not to be inferred that these following described ways of serving suppers are any less the ways of the *haut-ton*, are any less fashionable and proper than the regular set table because they are specially referred to the places of limited accommodations, they are simply less troublesome, stiff and formal, and their very informality causes these methods to be chosen in places where the facilities are as ample for any other method. The stand-up supper is credited to the inventive genius, perhaps we might say to the leader-like boldness, of Ude, the celebrated cook or maitre d'hotel to one of the later French kings, Louis XVI, perhaps, and who flourished

about a century ago. It was the stand-up supper idea which first made him talked about in every fashionable gathering, for there was a touch of philanthropy about it on his part, and the court beauties praised him for his sympathy with their dilemma—they could not sit down and were doomed to see the most magnificent feasts spread out of which they could not enjoy a morsel. The peculiar fashions in dress at that time caused the trouble. A lady fashionably attired for a ball could not sit in a chair without ruining her dress, and most of them in consequence made martyrs of themselves by not tasting snpper, preferring to stay so crinolined, starched and frilled till the close of the festival rather than eat at the sacrifice of their toilettes. Ude said, when he was catering for these brilliant court festivities, that as fashion could not come to the supper, the supper should come to fashion, and he set his tables and spread his feasts without having a chair in the room. He filled the dishes with small-cut dainties, placed them on raised sideboards in front of great mirrors and placed at each place nothing to eat with but a fork, and, naturally, for this accommodating change of custom the brilliant beauties were grateful and the stand-up supper was thereafter the proper thing throughout the fashionable world. Ude and the fashion makers of that time "builded wiser than they knew," for the resort to the stand-up method has helped out unnumbered thousands of caterers as nothing else would. A man has a large entertainment to serve; he can secure a hall or some place that will answer for one, but if is unfurnished; he can make impromptu tables of planks upon trestles, can cover them if need be with the finest damask tablecloths and then his roughly made tables may serve the temporary purpose as well as if they were mahogany and marble, but it may be very difficult to procure chairs and rough boards for seats will not do. Or it may be the supper is calculated down to the lowest degree of cheapness; to procure chairs for so many will neces-



sitate the employment of wagons and hands to bring and carry back and would greatly increase the cost of the entertainment. In such cases the stand-up supper is resorted to. But more frequently it is adopted because of the scarcity of room. Even while the people are dancing one side or one end of the hall can be taken possession of by the caterer, steward or headwaiter and long tables can be set. It is better in such cases if there can be a screen to temporarily part off that part of the room; it may be even worth while to have such a screen made for the purpose. Then the table or tables are set almost the same as for dinner, but with the plates nearer together, with as many plates and forks as there are guests. It is an object to do almost entirely without waiters, but place the decorated dishes of meats—everything ready sliced—the salads with a spoon in each dish, the small pastries, all of individual size and everything else, except ice cream and coffee, in numerous small dishes quite near together so that there will be no need of waiters, but every gentleman can reach a portion of everything for any lady, and not see something different or better further down the table—that is to say: the tables should be set exactly alike from one end to the other with a portion of every kind in everybody's reach.

But here is a grand caution to be observed. The ice cream and coffee have still to be brought in and the people will be so closely packed together at the tables these trays cannot be carried in behind them without risk of the direst accidents to the ball dresses, besides the awkwardness of everybody having to turn around and step aside to admit the service. Nothing is more frequent than to see these ill-considered arrangements put into operation during the season of public entertainments, the difficulty seeming never to be thought of until it is experienced. The ways to avoid it and admit of a little waiter-service all through the supper is to set double tables; that is two tables or even broad boards nearly together, but with just room

enough for a waiter or two to pass down between them and hand the cups of coffee over, the guests occupying only the outside of the two long tables. The most convenient of all is to set the tables in horse-shoe fashion or a hollow square, the servers being inside, but where there is not room for them the tables may be ranged along the wall, with only just room enough between the wall and tables for waiters to pass along.

#### THE BAZAAR SUPPER.

This is the prettiest form of stand-up supper—it might almost be termed the walk-around supper. It admits of the supper being spread in several smaller rooms where there is but the one large enough for dancing, and tables may even be set in hallways and verandas. It is like the going from one table to another for different viands at the festivals and bazaars which the ladies conduct in every town during the season. In preparing for a large number, however, it is necessary to have a number of tables set exclusively with meat dishes—the cut meats, salads, sandwiches, etc., and other tables beyond containing only sweets—the berries and cream, cakes, coffee, confectionery, etc. Some evening entertainments of many descriptions besides balls and hops are very successfully managed on this plan, where people stroll by twos to the tables and eat standing though the simultaneous seating of so many would be quite impracticable.

#### THE HANDED SUPPER.

It is not to be denied, however, that the stand-up supper is but the meal of expediency; not the most comfortable for the participants, but only the best that can be done under certain circumstances. It may well be supposed that the very court ladies, for whose benefit it was first instituted, would have preferred to be seated if they could. There is another motive for the stand-up repast which has not been mentioned, that is the desire to cut the supper short, for the people who would sit perhaps an hour in leisurely enjoyment at a regular set table will get through a

stand-up in fifteen minutes, a very important consideration where many speeches have to be made in another hall, or a number of figures of a german gone through before daylight comes.

The real social hop supper is the handed-around one, the best known way and most generally adopted in hotels, and next to the regular set table the pleasantest. This can be managed in two ways, of which the plainest is to serve everything on trays brought from the kitchen or pantry, the guests remaining seated in the ball room. If it is the hotel dining-room the tables have been carried out, and all else, but the chairs remain ranged around the walls. The man who "calls off" the dances announces that after the next dance refreshments will be handed around by the waiters and ladies and gentlemen are requested to keep their seats where they are. When the time arrives waiters come in and hand a napkin to each of the guests, who spread it on their lap, and other waiters follow with trays filled with small plates, filled as at private receptions, with portions of perhaps three or four different kinds; for example: a spoonful of shrimp or lobster salad, a slice of breast of turkey, one or two beaten biscuits, three or four pitted olives, and a fork; or a portion of chicken salad, a grated tongue sandwich, a slice of boned turkey with currant jelly, a buttered biscuit and a pickle or two. As soon as all are served with these the waiters begin to bring in trays of ice cream and cake—the necessity if condensation requiring the saucer of ice cream or punch-glass of sherbet to be placed on the same plate with the two or three pieces of cake and a spoon—and pass around to whomsoever may be ready first, taking up the meat plates and replacing with the sweets. It does not work well, unless the waiters are well accustomed to it and watchful, to let one go along and take up the meat plates and another follow with the sweets, as some are sure to be missed altogether. Each waiter should have but a small load easily handled and make the change complete as

he goes along. After that coffee is offered in the same way, while lemonade or glasses of water should be passed about the room freely by other waiters during the whole time of supper, until all hands are required to gather up the plates and napkins at the finish.

#### THE ORNAMENTAL HANDED SUPPER.

The last described being the plainest and easiest, the portions on the plates all prepared outside and no whole dishes having to be shown, is the sort of supper which hotel-keepers can best afford to give in a complimentary way to their guests, as they are so often obliged to do, and is for many reasons the least troublesome and least expensive. Here is another way of doing nearly the same thing, which perhaps may be claimed to be the best of all (but only for genteel people who can be depended on to behave well) as it gives a chance for display and leaves the most lasting impression upon the visitors. It is to bring a table or two or three, of the ordinary small size, ready set with some tall ornamental dishes or pyramids into the dining room when the dancing ceases and serve the supper to the people, all seated as in the other instance, from these tables instead of from the outside. In this service there is a little less of the "keep-your-seat" sort of restraint than by the other way. The tables hold something to be looked at and it follows that the people walk around them to see what there is, and, later on the gentlemen have a chance to assist the service in a way which they generally are very glad to do by helping the ladies to some coveted dainty from the tables or replenishing a plate before the waiter's attention can be secured. Nevertheless, it is a napkin supper like the last, and these *serviettes* are to be passed around (only to those who are found seated), and then plates with portions of three or four dishes sent to them from the tables as fast as they can be filled and distributed.

It is an object to make the table or tables hold all that is required for the supper.

They may be set while the dance is going on, in the kitchen or carving room or any handy place and when the time comes carried in by a sufficient number of hands through the doors into the dining room without disarranging anything. In the center may be a tall piece of the pastry cook's best work; a number of dishes of salad all decorated should be placed at intervals along with all other such dishes as have been suggested already for the supper with small set tables, the grand advantage of this style being that one elaborately ornamented dish of a kind is sufficient for all the company to see, while the other way calls for one such for every separate table. After the meats have been served the dishes may be removed and the moulded ices or plain ice cream and wine jellies, charlotte russe, orange baskets, meringues, or whatever could not be crowded on the tables at the first setting may be brought in their places and served from

the table as they were. It is quite essential in setting these show tables to allow room enough for piles of small plates, glass cake plates, glass jelly saucers, punch cups, forks, spoons, and a few knives besides the crockery on a side table for the waiters' use, in order that the guests may have facilities for helping themselves and each other when the service is slow. All ornamental cakes for such a supper should have a small section already cut out and a knife placed ready, to show that they are for use and not for ornament only, and then the quantities needed for the supper may be calculated according to rules already given so closely that these decorated affairs will have to be cut up in order to make enough—however, when there are not so many people present as provision was made for these larger pieces, like decorated hams, iced cakes and galantines cased in jelly, are the dishes best worth reserving.

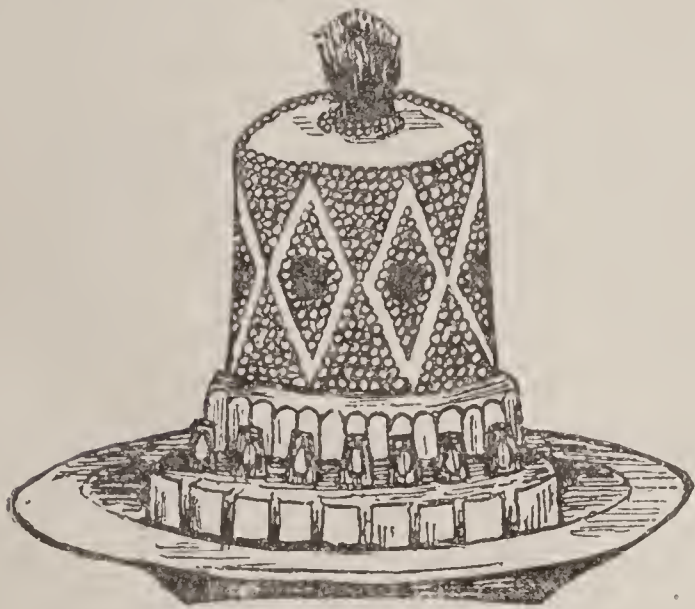

A CHARTREUSE OF VEGETABLES.



A TURBAN OF FILLETS OF FISH.



# THE STEWARD'S HANDBOOK.

PART THIRD.

---

COMPRISING

## Catering for Private Parties

A GUIDE TO PARTY CATERING.

WEDDING BREAKFASTS, FANTASIES OF PARTY GIVERS,

Model Small Menus and Noteworthy Suppers,

WITH PRICES CHARGED.

ALSO,

## *CATERING ON A GRAND SCALE*

ORIGINAL AND SELECTED EXAMPLES OF

MAMMOTH CATERING OPERATIONS, SHOWING THE SYSTEMS  
FOLLOWED BY THE LARGEST CATERING ESTABLISHMENTS  
IN THE WORLD.

ALSO, A DISQUISITION ON

HEAD WAITERS AND THEIR TROOPS.

---

BY

JESSUP WHITEHEAD.

---

CHICAGO.  
1889.



## CATERING FOR PRIVATE PARTIES.

---

Large catering establishments are like large hotels, few in number, of slow growth, costly to rear, expensive to carry on, difficult to buy or succeed to, but still there is small work for small caterers in tens of thousands of places, and real demand for skill and talent in that line the same as for excellent cooks and waiters in hotels. It is, of course, a peculiar line of work taking it all together for which only a few are adapted; it is not sufficient to be a good cook, there must be a special knowledge of the dishes most suitable for party suppers and dinners and of what is fashionable, which may entirely exclude the things which a cook may beat the world at for hotel dinners, and, in addition, there must be a knowledge of table setting and waiter work and various matters of propriety. The beginnings of the party catering trade are, however, simple enough. A man keeps a small restaurant or bakery and confectionery, or all combined, and is applied to by some simple-minded lady who asks him how much he will charge her to make and bake a cake for her party if she furnishes the materials, or what he will charge to roast her turkey if she sends it already prepared for cooking and sends butter to baste it with, and how much butter will it take? The man gives a smiling and courteous answer, whether he accepts such a contract or not, and the next may be a lady who has heard talk of some fine thing, perhaps a fillet of beef, larded, being served at a private party somewhere and asks if he can furnish such a dish for her coming entertainment, is probably pleased and proud to find that he can and may end by giving him an extensive order and his first opportunity to show whether he is capable of doing the society party work of the town. A man who is a cook

only finds one who is a head waiter or competent to be one; a waiter or butler starting in such a business finds an accomplished cook, and the two together make it go. Cooking and service must go together.

In tens of thousands of cases where parties are given, the right combination is not available. Society entertains everywhere; the ladies carry on the service part and only call on the cooks. There are numbers of cooks in every city of medium size and in some large towns, who never take regular employment, but hold themselves for all such odd jobs of cooking for parties, in private houses, and sometimes take little contracts, hire waiters, furnish everything and carry an affair through themselves. For cooking by the day they get good wages, ranging from five to ten dollars a day or for the day and part of the night taken up in serving the feast, and for some elaborate spreads the work of preparation may keep them employed for a week, and one who gains a reputation for special skill and reliability may be employed every day during the social season; may have more offers of employment than he can accept; may secure an advanced price for his services, but as in all other lines "it is the longest pole that knocks the persimmon," the man must excel in something or he will never be more than a laborer. There is never a private entertainment but the lady at the head of it would, if she could, have something to beat some other party; would like to have something which her friendly rivals have never had, particularly anything mentioned in the fashion papers or fashion correspondence, as in vogue somewhere, but which no lady of her round of acquaintances has yet been able to secure. Then the caterer

of whatever grade who can furnish the most novelties comes to the top. This is really a very serious phase of the whole society catering business from its smallest stage, where some new cook with a bunch of novelties can come and take the bread out of the mouths of the old residents, to the largest establishment, which is obliged to change from china to silverware, from silver to glass, from flowers in general to flowers of one or two rare sorts, from banks of moss and trailing vines on the table to tall vases only, all because of the changes of the fashions, and is bound to be on the watch to import every new idea and be ready to supply the newest favorite dish, as otherwise the class of patrons who are able to make high-class catering most profitable to the caterer will send away and import for themselves what they cannot procure at home. Small catering businesses are often offered for sale like any other business, and a man well posted in the requirements, at such times may find his opportunity to step in and build up an important and profitable trade where another had been "poking along" or failed entirely.

#### LADY CATERERS.

Many ladies are engaged in catering for private parties; they may be found in every town and city. They usually carry on some other small shop business or a ladies' restaurant for down town shoppers; and do little or none of the work themselves, but are acquainted with the people who give parties and with the requirements of several kinds of entertainments, and know all the available hands for such employment, the cooks, waiters, wagoners, house-cleaners, and where they can be found, also where silver and other table ware can be had for hire, and prove themselves friends in need to many who find themselves obliged to entertain, yet lack the experience necessary, and these caterers make a good income solely by employing others. The following, clipped from a society paper, shows still another department for ladies, much like the place occupied by the

steward of a hotel. This one indeed is the manageress, as they are called in England, for the time being. A man caterer called in and given entire charge of a reception or other party indeed does all that this lady does, if it is required of him, sending the proper hands to look after the silver, etc., making out the menu and getting it printed and ordering or furnishing everything for a round sum; still the lady fills a different position in standing in place of the lady of the house herself and being the employer of the caterer and florist, perhaps, besides.

"A New York lady, who had made her father's dinners famous by their elegance and perfection, was left penniless. She knew that many ladies refrain from dinner giving because they feel unequal to the ordeal, but are quite willing to pay any one who can relieve them of the responsibility and worry. An old friend of social position to whom she unfolded her plan of dinner superintendence agreed at once to employ her, and influenced her wealthy friends to try the novel plan. It worked admirably, and she probably earns more than any lady teacher in the city. Her plan is to go to the dinner giver as soon as the invitations are sent out, and discuss the courses, etc. She knows just what is in season, and does the marketing if the lady wishes. She finds out what sum the hostess is willing to expend for flowers, menus, etc., and buys them for her, taking great pains to get novel and artistic designs. The afternoon of the dinner she sees that the table is properly laid, inspects the polish of the silver and the lustre of the glass, makes sure that the changes of plates, etc., are ready on the sideboard, attends to the finger-bowls, and arranges the shades on the candles to secure that soft radiance that ladies find so becoming. She foresees every probable emergency and provides for all contingencies that may arise."

#### MORE RULES FOR STEWARDS AND CATERERS.

Scarcely ever two party affairs are exactly alike and set patterns seldom fit the



case, but the individual comes in and exercises his own skill and knowledge within certain bounds of propriety and good taste. Some rules have been laid down in a former page, by which a man may take a pencil and paper and approximate very closely the amount of provisions which will be necessary to prepare for any given number of people, and how much it will cost him can be determined by finding the prices prevailing in his markets. Then questions are raised of what is right and proper, as, for example, "should a soup be served at a wedding breakfast?" (which is really an elaborate luncheon and not the breakfast ordinarily understood) or "what dishes should be served at such and such a high-class entertainment?" and so forth, and as a guide in such matters likewise the following rules are offered:

1. To determine whether this thing or that is proper, examine the many *menus* of all sorts of fashionable entertainments; which are to be found abundant in these pages and are printed for the very purpose of reference.

2. To know what to give and what to charge for a high-priced spread, look over the large bills of fare with prices attached of the high-class restaurants, likewise to be found in these pages, select from among their dishes and take the prices for a guide what to charge, remembering possibly, if the occasion requires concessions, that those restaurant dishes are generally enough for two persons, if not more. It is claimed for the Hotel Richelieu of Chicago that each dish served for an individual order is sufficient for three or four. In some establishments they never divide any ordinary sized fish—nothing except salmon or halibut to cut into steaks—the rule is to buy fish of a suitable size, two or three pounds each, and serve nothing but a whole one to each customer. At high-priced suppers generally the same rule obtains, each one of the guests has a one-pound or two-pound trout or pompano or bass set before him to take what he pleases from, and when that is removed a

whole broiled teal or large portion of any other larger fowl, and so on through. Cheaper dinners and suppers in courses have divided portions in large dishes passed along the table.

3. When deciding what viands to order select the least common for the locality. Grouse in Kansas has been so common that the farmers' hands refused to be fed upon it, demanding other meat; people in the Rocky Mountain towns reject antelope and think little of black-tail deer because they have a surfeit of them, and still these all are prime delicacies in New York. Something far-fetched, unusual, novel should be introduced when possible, but with judgment not to exclude standard favorites which will be expected as well.

4. To know what special sorts of food to provide for entertainments given by various nationalities or people from distant sections, look over the menus of similar feasts given in other places by competent parties, generally by caterers of the same nationality, which likewise may be found in these pages, and refer besides to remarks on such national cookery also discussed in other pages under the proper letter.

5. To excel as a caterer, keep well posted on what is going on by reading fashion correspondents' letters in the papers, and the hotel and catering journals. Most of the "new wrinkles" may be trivial in the extreme, yet one never knows which of them will "catch on" and turn out to be a fashionable craze. Society entertainments were supported during one season at least almost entirely on "cheese straws," and another season or two on "salted almonds." The whole catering world is a company of inventors constantly seeking for some new thing, and he who cannot invent for himself may learn from those who can, if he cares to watch.

6. Look over the *dictionary of dishes* and learn in how many various ways the same edibles may be served, and find suggestions and new wrinkles applicable to every conceivable occasion.

## A GUIDE TO PARTY CATERING.

## ANNIVERSARY BALL SUPPER FOR 200.

The committee wanted it "fine" for \$5 per couple including ball. One hundred couples expected. It was a good-sized town (called a city), with two or three hotels, but without a regular caterer in business. Committee applied to a hotel *chef*, who undertook the supper for a fixed sum for the labor only, the committee to supply everything according to written requisition. Committee secured the town hall for dancing and a large vacant store underneath for the supper room, with large room at the back for kitchen, borrowed or hired the various utensils found in a neighboring restaurant, which was then closed awaiting a purchaser, and borrowed 400 pieces of silver from a summer hotel, then closed. Glasses, plates, etc., obtained from local stores. Two long tables were set and nearly everything was set upon them. Chairs were obtained from various places, principally from the hall or "opera house." A bill of fare was printed, not for any use to order from, everything but oysters and ice cream being in sight on the tables, but from motives of display. This was the supper provided:

## MENU.

	Raw Oysters.		
Celery.	Pickles.	Cold Slaw	Olives.
	Fried Oysters.	Stewed Oysters.	
Cold Wild Turkey.		Cold Roast Chicken.	
	Cranberry Jelly.		
Chicken Salad.		Shrimps, with Lettuce.	
Mayonaise of Lobster.		Hollandaise Salad.	
	Truffled Galantine in Aspic.		
Decorated Ham.		Decorated Buffalo Tongues.	
	Newport Tartlets.	Curacoa Bavarian.	
	Limon Butter Tartlets.		
	Wine and Fruit Jellies.		
	Meringue Cakes.	Glazed Cream Puffs.	
		Chocolate Layer Cake.	
Candies.	Delmonico Ice Cream.	Lemonade.	
Oranges.	Apples.	Nuts.	Raisins.
Cheese.	Crackers.		French Coffee.

## PROVISIONS AND MATERIALS USED.

Oysters (bulk) 10 gallons, of which 3 gallons were used raw, 3 gallons stewed, 4 gallons fried.

Turkeys, 80 pounds.

Chickens, 50 pounds. That was the quantity actually used, though the committee became excited as preparations went on and thought there would not be half enough, therefore had more prepared which was left over at last. Had and used 3 turkeys boned, stuffed with meat of 6 of the chickens; 4 chickens (fowls) made enough salad. Remainder, 5 turkeys and 4 chickens were sliced for cold roast, and all eaten.

Ham, one, weighed 11 pounds, but little used.

Smoked tongues, 4. Purported to be buffalo tongues from Montana. Used three sliced and decorated, other one in galantine stuffing.

Truffles, one \$1.50 can. All utilized for outside decoration.

Shrimps, 12 cans, all used.

Lettuce, 2 dozen heads, all used.

Lobsters, 2 cans. Not much needed. More for display of kinds in menu than for real use.

Potatoes, for hollandaise salad, used about 8 pounds.

Celery, 6 dozen heads, just right as ordered; used best part in celery glasses on table, remainder in salads.

Cabbage, 2 heads, about 8 pounds, used most for slaw with oysters.

Beets, used about 3 pounds in decorating salads.

Cracker-meal, for breading oysters, used 12 pounds.

Lard, for frying oysters and for shortening in biscuits and pastry, used 20 pounds—oysters frying is most destructive of lard, as it soon becomes too dark and thick with cracker dust for further use.

Butter, used for all cooking purposes (none on table), 10 pounds.

Flour, used 30 pounds.

Baking powder, used 1 pound.

Sugar, for all purposes, including lemonade, used 30 pounds.

Milk, used for oyster stews and other purposes, 12 gallons.

Cream, for coffee and other purposes, used 3 gallons.

Chocolate, for cakes and puffs,  $\frac{1}{2}$  pound.

Currant jelly, for tartlets, 1 pound.

Gelatine, for wine jelly, orange jelly, etc., and for aspic, used 10 packages or about 1 pound.

Sherry, for jellies, 1 quart.

Curacoa, for Bavarian cream, very small quantity, used 1 pint.

Extracts, used 4 ounces.

Eggs, 15 dozens actually ordered, needed and used (but, as in case of turkeys, committee anticipating a greater crowd, caused the using of 10 doz. more, product left over and not counted herein).

Of the 14 items above was made and all eaten: Cream Puffs, 150; Biscuits, 200; Puff Paste Tartlets, 100; Ice Cream, 6 gallons; Wine Jelly, 8 quarts; Aspic Jelly, for meat decoration, 2 quarts; cake, about 24 pounds, needed on table for show, but half eaten, as all took puffs and pastries.

Besides these were used:

Bread, 5 loaves—nearly all preferred the beaten biscuits.

White Wax, for ornamental purposes, \$1 worth, together with some mutton fat.

Paper, 2 kinds, 2 quires.

Olive Oil, 2 quarts.

Olives, 2 bottles.

Lemons, all purposes, used 6 doz.

Pickles, 2 quarts.

Coal for range, used 500 pounds.

Salt, for freezing, etc., 25 pounds.

Ice, nominal, winter, plenty free.

Coffee, used 8 pounds Java—ought to have had 10 pounds—great run on coffee and nothing large enough to make it in.

It would not serve any useful purpose to say what the supper above detailed cost. The amounts and quantities will be found trustworthy as a guide for similar occurrences; the probable cost in any case can be ascertained by reference to prices in the local markets. The number at the tables, known by the number of chairs, was quite 200 including the promoters of the affair, committees and complimentaries, but musicians and others at second table were so many additional for which the same spread was sufficient.

The waiters were paid by the committee, it being in a country town they found waiters enough to volunteer for the occasion for little or nothing; if paid, the 15 or 20 waiters and helpers would have cost \$10 to \$15. The kitchen work required assistants who were paid altogether \$5.50, the skilled labor together with time lost in preliminary arrangements amounted to 5 days and the night of the supper, besides.

#### A YOUNG LADY'S BIRTHDAY RECEPTION FOR 50.

Had 2 small turkey galantines; one sliced on plates, other decorated in a mould of aspic on table and about half used.

Chicken salad of 4 chickens and 1 doz. heads of celery and one quart of dressing, all used.

Charlotte russe, had 50 individual size in ornamental white paper cases; cake portion made with a 3-pound sponge cake mixture, that is, with 3 pounds sugar, 2 doz. eggs and  $2\frac{1}{4}$  flour; filling with 3 quarts whipped cream stiffened with 1 package gelatine, 1 pound sugar.

Meringue shells filled with jelly; had 50 pairs, size of ducks' eggs, baked on boards, scooped out, filled like saucers in pairs, with 2 colors of jelly cut in cubes and mixed—had 3 quarts jelly, part maraschino, remainder port wine.

White cakes and layer cakes decorated, on table.

Bisque of preserved ginger ice cream; had 8 quarts.

Lemonade. Biscuits. Candies. Malaga Grapes.

Quantities about right; a little of each left over, but not more than was wanted.

#### SNOW-BOUND DINNER.

Dinner for about 200 railroad passengers snow-bound on a train in the far West; dinner given free by the railroad company at the next station reached. Made a western hotel dinner, but greater part ready set on two long tables.

Cooked and used:

Fresh meats, 100 pounds (raw weight).

Ham, 20 pounds.

Chickens, 40 pounds.  
 Clams in baked chowder, 12 cans.  
 Oysters in soup, 20 cans.  
 Lobster in salad, 8 cans.  
 Potatoes, 75 pounds.  
 Pies, 48.  
 Tarts, various, 150.  
 Cake, 28 pounds.  
 Pudding, 4 quarts.  
 Charlotte russe, 12 quarts, in 15 moulds on tables.  
 Jelly, 13 quarts, in 18 moulds on tables.  
 Bread, and various vegetables, not counted.  
 Coffee, about 15 gallons.

#### CHURCH FESTIVAL.

"To be as cheap as possible," to raise money to pay the pastor. Committee furnished the raw material only; the hotel-keeper gave everything else, use of rooms, fire, lights, cooking and incidental labor.

The raw material cost the church committee about \$15. Prices were higher then than now. Had about 100 persons to supper, which was made up of:

Ham sandwiches, 7½ pounds, of which 5 pounds was ham, net trimmed, which is equal to a 9-pound ham raw.

Pressed corned beef, sliced on dishes, decorated, 4 pounds.

Yeast-raised short biscuits, 100.

Bread, 6 loaves, sliced.

Fancy small pastries, showy, cheap, 100.

Cream puffs, 120.

Lemon jelly, 3 quarts.

Macaroons and kisses, made of 3 pounds sugar, 1 pound almonds.

Cakes, about 9 pounds.

Coffee, used 4 pounds Java.

Tea, used 4 ounces.

Cream for coffee, 2 quarts.

There was no ice cream.

The cost of material was about 15 cents per head. About 12 pounds butter was used, some upon the table, rest in cakes, etc., and 15 pounds sugar, and a gallon of milk, some citron and lemons.

#### CLUB RECEPTION.

For 26 persons, both ladies and gentlemen, the material cost about \$60, of which

\$20 was for terrapin. Flowers and florists services about \$40; catering about \$40; and with the hire of ten different sets and patterns of china and other incidentals the total cost to the giver of the party was something over \$200, without the wines, or, making a round estimate to include wine, say \$10 per plate. The caterer was instructed on various points and, among others, not to give them a clear soup—"they were so tired of clear soups."

A table was handsomely set in the club drawing-room for this special occasion, not to disturb the regular daily arrangements of the club; a florist being employed to decorate it with designs and bouquets and to festoon the chandeliers. Several tall decorated dishes and ornamental cakes were set on table amidst the green.

First. Passed around pony glasses of whisky cocktail.

Second. Cream of cauliflower soup—cauliflower (from a distance) and soup cost about \$1.25.

Third. Deviled oysters in shell, cost with garnishing about \$2.50.

Fourth. Celery, imported, \$2.50.

Fifth. Turkey stuffed with chestnuts, 1 turkey \$1.40, with vegetables, jelly and trimmings whole cost \$3.75.

Sixth. Brains sautés in butter, with vegetables, garnishing, etc., cost \$4.35.

Seventh. Terrapin with wine and garnishings, \$21.40.

Eighth. Curacoa punch, \$1.60.

Ninth. Roast quail, \$4.30, *bardes*, chips, endive salad, garnish, etc., whole cost, \$6.20.

Tenth. Ornamental pieces (galantine of partridges flanked with larks in aspic), cost of material, \$5.10.

Eleventh. Harlequin ice cream and moulded jellies in ornamental borders filled with maraschino whipped cream, cost \$3.60.

Twelfth. Assorted fruit, \$3.50.

Thirteenth. Coffee, cream, incidentals, about 75 cents.

Wines, etc., from the club cellars.

## COLD LUNCH FOR 300.

Governor's Guard and other military companies passing through.

Prepared and used:

1. Salted round of beef, bound around with twine, boiled, pressed while cooling; raw weight 50 pounds, weight when cooked 37 pounds. All used.

2. Bread, 48 bakers' loaves.

3. Cold ham, 2 hams, raw weight 18 pounds; weight when cooked 12 pounds. All used.

4. Ham sandwiches, 300; made of 2 hams, raw weight 25 pounds, net cooked meat 18 pounds.

5. Salad of 10 fowls and 6 doz. heads celery, some cabbage to mix in; about 20 quarts of salad on 20 dishes.

6. Tarts, puff paste with apple jam; 300 all used.

7. Butter on table, used 10 pounds.

8. Cake, on table, 20 pounds; half left over.

9. Ice cream, 6 gallons used.

10. Fruit on table, apples, oranges, not counted.

11. Coffee, 15 gallons; not much left over.

12. Sugar on table, used about 12 lbs.

13. Milk for coffee, mustard, sauces, etc., not counted.

Had 30 waiters.

## PRIVATE RECEPTION.

For 70, in May, at a family residence; parlor and dining room connected by sliding doors. Hostess provided material on written requisition; work done in the house. Florist called in, decorated dining room with a central design and festooned room and chandelier. Had on table six decorated dishes, of which two were cakes with sugar work and baskets about 20 inches high, set to flank the floral design in center; two were decorated salads at opposite corners of table; one was a border mould of jelly filled with whipped cream, the other rings of meringue baked separately, built up, decorated and inside filled with stiffened cream and chopped jelly. More

of same kinds on dishes in the pantry outside, together with:

1. Rolled sandwiches.

2. Shaved smoked tongue.

3. Cheese straws.

4. Shrimp salad.

5. Chicken salad.

6. Claret cup.

7. Assorted cakes.

8. Mammoth strawberries with powdered sugar.

9. Ice cups or *bombes*, of red raspberry water ice frozen in 6 doz. tumblers and filled with green pistachio ice cream.

10. Vienna coffee in small cups.

Guests, being over 70 in a private house, sat around on sofas, chairs, settees, etc., informally, and stood around the dining room, and waiters carried plates from the pantry with portions to them. After first round gentlemen began and helped the ladies from the show dishes on table. Hostess made and served the coffee herself from a swinging silver urn in the dining room.

Expenses without provisions: florist, \$15; music, 3 pieces, \$7; caterer, \$25; 5 waiters, \$5.50. Incidentals, extra hire, wagons, carriages, etc., not counted.

## CATERING EXPERIENCE OF AN ENGLISH MANAGER.

"Many land owners give audit dinners (or rent day dinners) in hotels, when the tenant farmers come to pay their rent. These dinners are sometimes very cheap, still they are often attended by a large number of guests, and it requires some close calculation to render them profitable as well as successful. Served:

## DINNER FOR 6 AT 60 CENTS. (2s. 6d.)

Salmon and Parsley Sauce.

Roast Leg of Mutton.

Cauliflowers. Potatoes.

Rhubarb Tart. Custard Puddings.

Bread. Cheese. Butter. Salad.

Wines or beer extra. (No coffee.)

## DINNER FOR 30 AT 65 CENTS. (2s. 9d.)

Spring Soup.

Turbot and Lobster Sauce.

Boiled Fowls. Bacon.

Roast Beef. Horseradish Sauce.

Two Vegetables.

Apple Tarts. Cream.

Bread. Butter. Cheese. Salad.

Wines or beer extra.

DINNER FOR 150 AT 65 CENTS. (2S. 9D.)

- Mock Turtle and Clear Soups.
- 2 Ribs, 2 Sirloins Beef.
- 1 Boiled Round of Beef.
- 2 Roast, 2 Boiled Legs Mutton.
- 8 Veal and Ham Pies.
- 50 Cauliflowers. 1 Sack Potatoes.
- 16 Rhubarb Tarts. 16 Cabinet Puddings.
- 150 Dinner Rolls.
- Bread, Butter, Cheese, and Biscuits.
- Wines or beer extra.

LUNCH FOR 50 AT \$1.20. (5S.)

- Clear and Ox-tail Soups.
- COLD.
- 2 Fore Quarters Lamb. 1 Sirloin Beef.
- 2 Veal and Ham Pies. 2 Tongues.
- 8 Roast Fowls. 1 Ham.
- 2 Mayonnaise Salmon. 4 Lobster Salads.
- 4 Jellies. 4 Creams. 4 Fancy Pasties.
- Wines, etc., extra.

LUNCH FOR 275 AT 75 CENTS. (3S.)

- 90 Quarts Clear Soup.
- COLD.
- 4 Large Joints Roast Beef.
- 2 Large Boiled Rounds Beef.
- 4 Roast Legs Mutton.
- 48 Fowls.
- 2 Large Hams.
- 2 Galantines of Veal.
- 2 Pieces Pressed Beef.
- 8 Steak Pies.
- 8 Veal and Ham Pies.
- 18 Jellies. 18 Creams.
- 18 St. Clair Puddings.
- 18 Rhubarb Tarts in deep soup plates.
- 18 Mince Pies in deep soup plates.
- 250 Rolls. Cut Bread, Butter, Cheese, etc.
- 1½ Sack Potatoes. 75 Cauliflowers.
- Wines or beer extra.

“The autumn bills of fare can be served at the same rate; but substituting thick soups for clear, giving such fish as may be in season, and adding roast pork to the menu.

“To avoid confusion (if possible) I allot two rooms, one for the landlord, or his agent, to use as an office where each tenant pays his rent. The tenants wait in the smoking, billiard, or other public rooms; and, if they number only twenty or thirty, I have their dinner spread in the ladies' coffee-room, made private for the time being. But in cases where there are over a hundred I manage this way.

“We will take No. 3 dinner served as follows; I had three long tables (seating fifty persons at each) down the room, and a serving table top and bottom.

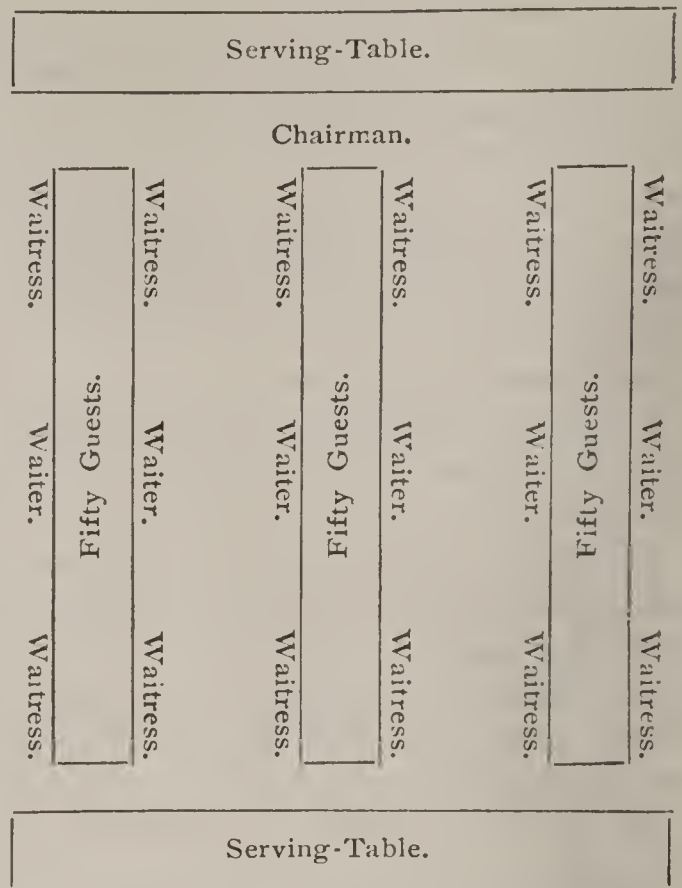

As the price was so low, I could not afford to hire special waiters, so placed my own, one on either side of each table, giving him two girls, housemaids or otherwise, one on each hand, thus allowing one waitress to every eight guests, and one waiter to nine ditto. Ten minutes before dinner time I marshalled them in their places, indicating how far down the table each was to look after the comfort of the visitors, and strictly enjoining that no one should *run about or wait on any part of the table other than that allotted to him or her*. Each waiter was instructed to keep a sharp look out all down his side of the table to see that the two waitresses were serving correctly, their *experience* not being equal to his.

“Having settled the question of attendance, I had the porters ready to bring up at a moment's notice the soup, joints, and vegetables all boiling hot from the kitchen. Four servers took their position at the top serving-table, another four going to the bottom. Directly the guests entered, the porters brought up the soup in the *stock* pots (covered round with coarse white cloths). There was no need for *hot* soup plates, as the liquor was actually boiling on the serving tables. The eight servers soon

supplied the eighteen attendants, who as quickly served the guests; and as they collected the dirty soup plates, the servers were carving the joints and pies, two of their number transferring the vegetables direct from the steamers into dishes to hand round as required. This arrangement ensuring, as it did, fresh and *hot* vegetables was much appreciated by the guests. I personally assured myself, by walking round the tables, that every guest was served, and properly served. Two young lads were deputed to go round with bread after the rolls were consumed, so that no one waited for that very necessary article, as is so often the case at large dinners.

"At the proper time the sweets were sent round, and such was the celerity of serving that the 150 diners were satisfied; everything (not wanted on the table) removed; and the chairman rose to make his speech *within the hour* from the time of first sitting down. The porters had been taking away the dirty plates, etc., during the dinner, so that when I withdrew from the room with the waiters and waitresses, having only been there forty-five minutes, I had nothing to do beyond dividing such sweets as were left amongst the girls, who had come from their ordinary occupations and assisted so willingly. I may here add I find a little thoughtful kindness like this makes them ready volunteers for any great pressure. As soon as the guests departed, I took the staff into the room again, and each one looked up and secured the various things belonging to their different departments, thus avoiding loss or confusion. Three hours after the dinner everything was in proper order again, and the usual business of the hotel was never at any time interfered with.

"The above hints will assist the experienced to serve dinners of any size, and the same rules may be carried out with regard to large *cold* luncheons. I have served the latter for 700 persons in less than one hour, with only fifteen waiters and thirty girl-helpers. In the case of the No. 5

lunch, *the fowls were carved and dished, and ham, pressed beef, galantines of veal, etc., sliced and served up on salad, and placed each side of the fowls.* All these make very pretty dishes, if nicely ornamented with colored kale, parsley, or flowers. No one, unless they try the plan, can conceive what a saving is effected by this mode of serving; for what would be only one joint can be made into a dozen dishes, and each person can help himself to a neatly carved slice, whereas few *can* carve under such circumstances, and much fewer *care* to be troubled to do so for strangers.

BASE BALL OR CRICKET LUNCH FOR 50 AT 60 CTS.

Boiled Round of Beef, about 20 lbs.  
Roast Sirloin (with horseradish), about 20 lbs.  
2 Beefsteak Pies, 2 Veal and Ham Pies.  
8 each Rhubarb and Gooseberry tarts. 8 Custards.  
Salad, Bread, Butter, Cheese, New Potatoes and Ice.

BASE BALL LUNCH FOR 75 AT 85 CTS. (3S. 6D.)

20 lbs. Pickled Salmon and Sliced Cucumber.  
18 Roast Fowls. 1 Ham.  
Fore and Hind Quarter Lamb.  
Boiled Round Beef.  
Roast Sirloin, horseradish.  
12 Fruit Tarts. 12 Velvet Creams. 12 Jellies.  
Plenty of Salad, Bread, Butter, Cheese, New Potatoes, and Ice.

BASE BALL LUNCH FOR 100 AT ONE DOLLAR.

Mayonnaise of Salmon, 30 lbs.  
Pressed Beef. 4 Pigeon Pies.  
Roast Sirloin Beef, horseradish.  
18 Roast Fowls. 4 Tongues. 1 Ham.  
12 Swiss Pastry. 8 Assorted ditto. 4 Fruit Tarts.  
18 Dishes Stewed Fruits. 6 Devonshire Cream.  
Plenty of Salad, Bread, Butter, New Potatoes, Peas, and Ice.

BASE BALL OR CRICKET LUNCH FOR 80 AT \$1.20. (5S.)

20 lbs. Mayonnaise of Salmon. 6 Lobster Salads.  
1 Forced Turkey. 2 Targets of Lamb.  
4 Pâtes de Foie Gras in Aspic. 4 Raised Pies.  
12 Roast Fowls. 1 York Ham. 3 Tongues.  
1 Roast Sirloin Beef. 8 Boiled Fowls "Bechamel."  
6 Dishes Compotes Fruit. 2 Genoise Pastry.  
2 Dishes Baba cakes. 2 Small Pastry.  
6 Dishes Fruit Tarts. 6 Custards.  
6 Dishes Stewed Fruit. 6 Devonshire Cream.  
Plenty Salad, Bread, Butter, Cheese, New Potatoes, Green Peas, and Ice.

"The foregoing were all supplied on the field, in a tent erected for that purpose. We did not provide the tent nor seats, but sent everything else, such as plate, glass cutlery, linen, kettles, saucepans, washing-up tins and cloths. We had a small American stove on the outside of the tent, and cooked the new potatoes and green peas.

when required—everything else was sent ready prepared from the hotel; but we dished and decorated the luncheon after its arrival, so that it looked perfectly fresh. Everything that would admit of it was carved beforehand and dished, so that guests could help themselves; the waiters cutting the heavy joints as required, passing round the vegetables, bread, etc., as wanted, and attending to the orders for wines, which were under the special charge of the headwaiter. Every bottle of wine, spirits, beer, or mineral water was booked to him, and after the luncheon he was required to return either the stock in full or its value in money. We made a sort of bar counter at the end of the tent so as to avoid all delay in serving. I may here add that this temporary bar did duty all day for whatever drinks were required. (Mem.: It is necessary to obtain a special license from the magistrates to enable any one to sell excisable articles at or in any other place than their own properly licensed premises; but you may pack any quantity from the hotel in a luncheon-basket without the special license, provided it is ordered and paid for in the hotel, and not retailed or sold afterwards.) When serving out-door luncheons, etc., be sure to be well supplied with *bread*, salt, etc., etc., corkscrews, champagne-nippers, ice, ice-hammers, needles, washing-up tins and cloths. I have known most excellent repasts almost spoiled by the omission of one or more of these very necessary articles. Also be careful to have a *plentiful* supply of good water carried up to the field, if there is not a well very near.

“I have always had the viands taken up in locked-up boxes, keeping the jellies, creams, etc., in their moulds till really needed to place on the table. The *chef* has gone up to the cricket field and turned out the sweets at the given time, as we easily procured hot water from the American stove for dipping the jelly and cream moulds into. At the same time he also carved and dished up the fowls, so they did not become dry from standing long ex-

posed. Flowers, parsley, and other garnishes should be put on the different viands the last thing, as they so soon lose their freshness.

“The above bills of fare are only intended as examples when the luncheons are given outside the house and at moderate prices. I have always found that simple, but substantial, dishes are much preferred by the hungry cricketers to what Shakespeare calls “pretty, tiny little kickshaws.” Should, however, the match-ground be near enough for the players to come to the hotel, a much more varied repast can be given for the same price, as the labor and loss of serving in the house is *nil* when compared with the trouble and expense of catering at a distance. I have had many cricket-luncheons served in the hotel when to the quoted bills of fare have been added clear soup—if the club wished—or some nice little *entrée*, such as mutton cutlets and fresh tomatoes, fillets of beef and mushrooms, lamb chops and asparagus, hot crabs or lobsters and cucumbers. This last dish, by the way, was always so much liked that we never could quite satisfy the many who wanted a second helping.

“It will be well to mention here that I have found it more satisfactory to supply *one good entrée*, but *plenty of it*, than a little of two or three kinds; for it is a curious fact nearly *all* want the same, and it is mortifying after an *entrée* has served about a dozen to find twenty other guests asking for that particular dish, and obliged to go without, whereas there may be a couple of *entrées* scarcely touched at all.

“I remember on one occasion serving fifty splendid hot crabs and cutting up twenty large cucumbers (in vinegar with pepper and salt, the same as would be served with salmon), and not an atom of either was left; whereas a dish of beef rissoles was untouched, and only one eaten from the chicken and ham patties.

“Do not forget to have plenty of ice on the tables, whether the refreshments be served in the house or on the field; nor yet when luncheon baskets are packed for



races or picnics. Much the same fare will do on any or all occasions; only when packing for races I have always had the fowls carved and tied together with white ribbon; salad nicely washed and placed in tin cases; salad-dressing and mint sauce made and bottled; butter, cheese, etc., etc., put into earthenware pots, with a plentiful supply of bread, salt, pepper, mustard, etc., not forgetting the corkscrews, nippers, ice,

ice needles and hammer; also napkins, crockery, cutlery, glass, spoons, forks, and requisites for washing-up purposes.

“NOTE.—Unless the committee finds the tents, seats, etc., an extra charge must be added for these in accordance with the hire-payment made by the hotel-keeper.”  
—From the *London Caterer and Hotel Proprietor's Gazette*.

### A RECEPTION.

COMPLIMENTARY TO A LADY AT A MEMPHIS HOTEL.

## —◆◆◆ MENU ◆◆◆—

### BOUILLON.

“From the hand to the mouth the soup is often lost.”—*Trans. fr. Fr.*

### CELERY.

### FRIED OYSTERS.

“An oyster may be crossed in love.”—*Sheridan*.

### PETITS BOUCHEES, AUX SALPICON.

“Such dainties to men, their health it might hurt,  
It's like sending them ruffles when wanting a shirt.”—*Goldsmith*.

### DEVEILED CRABS, IN SHELLS.

“He must have a long spoon that must eat with the Devil.”—*Comedy of Errors*.

### COLD—ROAST TURKEY.

### OX TONGUE.

“There's cold meat in the cave, I browse on that.”—*Cymbeline*.

### CANETON DESOSSE.

### GALANTINE DE VOLAILLE.

CAP.—What's there? 1ST SERV.—Things for the cook, sir; I know not what.—*Romeo and Juliet*.

### PAIN DE GIBIER, AUX TRUFFES.

“Ay! That way goes the game.”—*Tempest*.

### MAYONNAISE OF SHRIMPS.

“This sort were well fished for.”

### CHARLOTTE RUSSE.

“These trifles will lead to serious mischief.”  
—*Horace*.

### VANILLA ICE CREAM.

“You are the vanilla of society.”  
—*Sydney Smith*.

### ASSORTED CAKES.

“Would'st thou both eat thy cake and have it.”—*Herbert*.

### MALAGA GRAPES.

“Meaning thereby that grapes were made to eat and lips to open.”—*As you like it*.

### COFFEE.

“The cups that cheer, but do not inebriate.”—*Cowper*.

“Night wears away, and morn is near, the stars are high, two-thirds of night are past;  
The greater part,—and scarce a third remains.”—*Bryant*.

“On with the dance! let joy be unconfin'd; no sleep till morn, when youth and pleasure meet.”—*Byron*.

# FANTASIES OF PARTY GIVERS.

It has been remarked already, the whole world of party givers are constantly straining after something new, or, if not a fresh invention, something new to their own circle, and by way of showing what devices are hit upon, we will give specimens gathered from various sources. And, first, the series of dinners of one prevailing color.

## A PINK DINNER IN WASHINGTON.

"In the dining room the idea of a pink dinner had been carried out in every detail, even to the pink globes on the large chandelier. The centrepiece of the table was composed of an elongated square of ferns, the four corners formed of great clusters of odorous carnations, while from the middle rose long-stemmed and La France and American beauty roses. At each of the four corners were fairy lamps under pink shades. The silver candelabra were filled with candles under shades of the same color. The menu was printed on a broad piece of pink satin ribbon, fringed at either end, and bearing on the left-hand corner at the top the name of the guest for whom it was intended. The rolls at each plate, cheese sticks and wafers, were tied up in small bundles with a tiny pink ribbon, while the icing of the small cakes, confections, and ice cream were all of the same color. The individual salt cellars and punch glasses were also pink. A boutonniere of carnation, or pink rose bud, lay at each plate. On the mantels were large vases of white chrysanthemums."

## A YELLOW DINNER IN BOSTON.

"In dinner-party arrangements a pretty custom is rapidly gaining ground; this is to make one color in varied shades rule the roast, and to have one flower the presiding genius of the feast. Take the yellow, for instance. Golden-hued chrysanthemums would be the most appropriate

bloom to harmonize with this color in the shades of the large lamps on the side tables and sideboard, and the delicate fairy lamps marshalled on the dinner table. Careless posies of the same flower are suspended over the heads of the diners, and separate sprays lie carelessly at their sides, and grouped together, decorate the center of the table. All the service used at the meal must be in harmony, and in some instances the very cloth covering the table is of pale canary satin. At one dinner of eight a well-known entertainer carried out the golden lead in the viands themselves—the soup was golden, so also were the fish and its sauce, entrees, sweets, and dessert all following suit."

## A WHITE DINNER IN LONDON.

"During lent dinners *au blanc*, or white dinners, are fashionable. In many houses the fair, white damask tablecloths replace the covers of colored velvet, satin, plush, or sateens with their exquisite *surcloths* of laces, or, if colors are used, it is the soft violet shade, so beloved by the adherents to the third empire in France and the high church party in England. This is the menu of a white dinner recently given.

### MENU BLANC.

#### *Hors d'Œuvre.*

Huitres en Coquille.

#### *Soups.*

Potage au riz. Purée de Morue.

#### *Poisson.*

Brochet au Citron. Alose à la Marrons.

#### *Relevés.*

Poulette au blanc. Filet de Veau à la Père François.

#### *Entrees.*

Œufs Farcies. Rissoles de Bœuf. Filets de Canards aux Navets.

#### *Roti.*

Agneau. Carré de Porc Roti.

#### *Entremets.*

Crème de Noyau. Pannier de Roseblanc.

Frangepane de Moëlle.

Canapees de Fromage à la Diable.

#### *Glaces.*

Citron. Cerises Blanc.

#### *Dessert.*

## A VIOLET SUPPER.

"A 'Cinderalla' supper, recently served in Paris, was rendered quite charming by the free introduction of the modest flower which 'opens with the earliest breath of spring.' All the ladies wore violets in abundance on their white dresses, and each gentleman wore a button-hole of the poet-lauded flower. Supper was served at little tables—the *parties carrees*, or sets of four, being quite usual in Paris now. Each table was, instead of being covered with a cloth, strewed with a bed of fragrant pale-tinted violets."

## A DINNER IN SCARLET AND BLACK.

"One of the dinner-table decorations for this season is Mephistophelian, out of compliment, doubtless, to the great Lyceum success. It is done entirely in flame-color flowers with black foliage, and is beautifully diabolic. The candle shades are also flame-color, and the *menu* the same."

## A PINK ROSE DINNER.

"One of the notions in table decoration is a pink satin tablecloth of the very palest tone. Only eight inches of this is, however, visible, merely enough to allow room for the plates. All the rest of the table is hidden by grey gypsophila. In this is intermixed all tones of pink roses from the lightest to the deepest shade. In front of each guest is a slender glass vase with a rose. Those who have never tried the grassy gypsophila for decorating tables are recommended to do so, for it is both beautiful and durable."

## A WHITE LILY DINNER.

"The floral decorations at fashionable tables this season have been largely confined to one color. At a dinner given recently at the Russian Embassy a charming effect was obtained with one single kind of flower—the white lily. Every variety of this exquisite bloom was used, however, but beyond their own green leaves and creamy buds and a lovely bronze foliage, judiciously blended, there

was no mixture whatever, and a more perfect result could not possibly be imagined."

## A MERMAID DINNER.

"A fish dinner has lately been the fashionable novelty in New York. Not only was the *menu* unique, but so also was the costume of one of the belles who graced the occasion. The private dining-room was turned into a bower of bright green, with seaweeds in profusion and quaint embellishments of shells, while borrowed pictures of pisciculture and water completed the aquatic decoration. However, it was in one of the elaborate toilets that a clever conceit was most remarkably carried out. The wearer was a pretty girl, and belonged to a distinguished family. Her hair was loosened and embellished with sea-grass, a necklace and bracelets were pearls and coral; the sleeveless and low-cut corsage was delicate pink satin, shading off into the green of draperies fashioned in artistic imitation of a mermaid's lower half. The scaliness of a fish was imitated by means of bead-work, the skirt was narrow, and a short train was shaped like the tail of a fish."

## CROWNS, STARS AND DIAMONDS.

"The floral decorations at fashionable dinner-parties are often arranged on a novel plan. At a recent Belgravian dinner a crown was made the central feature of the table. The cloth was left white, and in the center was a white satin cushion, upon which was placed a crown of the most vivid crimson flowers, and from it long trails of crimson flowers reached to the four corners of the table; a few small dishes of flowers at the head and foot of the table completed it. But dishes or vases are very little used now—the flowers are arranged on the cloth. The star shape is a most effective form of placing them, and is most beautiful when a cunning hand has led the color by gradations, from a vivid center to a pale shade at the points, where the tapering ray should end in a single leaf.

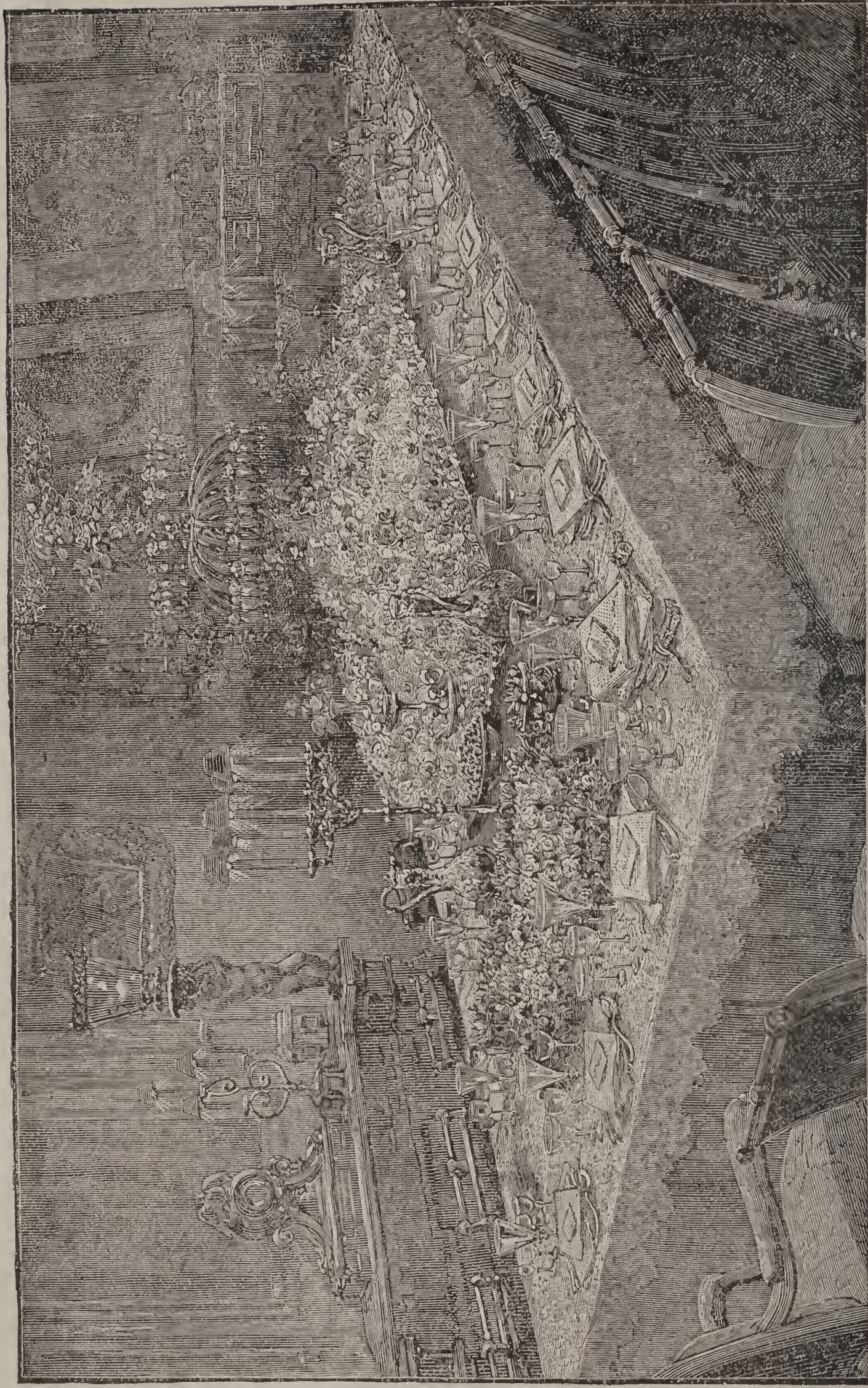

A DINNER TABLE.—Reduced from an Engraving in Harper's Bazar.

## THE PLATEAU.

The engraving on the preceding page makes it easy to explain what is meant by the very old and most enduring fashion of the *plateau* or central ornament of the dinner table. The table shown has no plateau strictly so called, but it has something in the place of it—a bank of moss and flowers. The plateau is, very often, a mirror laid flat on the table to represent a lake, and there must be—that is to say, there used to be—a rock castle or chateau, or monastery or temple, or something of the sort, in the center, with boats, swans, etc., around, and the edges of the mirror covered in any fanciful way to represent the shores of the sheet of water. This form is by no means abandoned. Sometimes now the fashion takes the shape of real water, with a fountain playing and live fish. Only so recently as President Cleveland's inauguration dinner—to be found mentioned further on—there was a large mirror laid flat upon the table, with at each end a ship built of flowers, and a sea-piece of the cook's make was set afloat on the mirror. Another thing to be noted is the large number of glasses at each plate. For several years now perhaps eight or ten—it has been the fashionable rule to place a different glass for every kind of wine all on the table at once before the dinner began, as seen in the picture. As indicating a change of this fashion there comes to hand, while this book is in preparation for the press, a letter from the *premier* of all catering correspondents, the Paris correspondent of the *London Caterer*, in which he remarks of “a dinner at the house of one of the richest financiers in France, and the dinner was worthy of the host:

“This dinner was served throughout on crockery representing the best old Rouen period. The glasses to each cover were numerous, though *it is now the fashion in Paris to put one glass to each cover*, and to change the glass at each fresh service of wine. It is also fashionable to change the set of plates with each course, that is to say, to have a plate of a different pattern of

porcelain for each new dish. The decoration consisted of a large *épergne* full of flowers, dishes of fruit, dessert, etc.

## MENU.

Potage Crème Princesse.  
Rissoles à la Pompadour.  
Turbans de Soles à la Cardinal.  
Filet de Bœuf à la Godard.  
Poularde à l'Ivoire.  
Quartier de Chevreuil, Sauce Poivrade.  
Croustade de Foie Gras Charvin.  
Salade à la Russe.  
Petits Pois à l'Anglaise.  
Gâteau à l'Officier de l'Académie.  
Glace Revenez-y.  
Desserts.

“The *filet de bœuf à la Godard* was an English sirloin served with trimmings of truffles boiled in cognac, mushrooms and cockscombs. The *poularde à l'ivoire* apparently owed its name to the beautiful whiteness and firmness of the fowl's flesh. The *quartier de chevreuil*, which was most delicious, was served with red currant jelly, a very great improvement, suggested to her, as my amiable hostess said, by the English fashion. The *croustade de foie gras* was a large timbale of most delicious crust. The *gâteau à l'officier de l'académie* was a sponge-cake decorated with cream. Its name was a topical allusion to the recent decoration of one of the guests, the most popular actor at the *Comédie Française*. As for the *glace revenez-y* (or come-back-to-the-ice), it was a *tutti-frutti* bomb of particular excellence.

“The wines served at this dinner were claret, champagne of two kinds, hock, and, with the *foie gras*, some most delicious *Romanée Conti*. This was served cold, after the fashion in Burgundy, and being cold made an excellent substitute for the mid-prandial sorbet, or iced punch, which, as will be seen, was wanting in the above *menu*. As a rule I prefer all burgundies at normal temperature. I found the *Romanée Conti*, however, on this occasion perfect, though cold. The above *menu* was written on rough-edged paper, with crossed spoons in the left-hand corner, the guest's name being written obliquely in the right-hand corner. Gaudy *menus* are out of fashion in Paris just now, and I am glad of the change.”

"At a dinner lately given by Mrs. Mackay (wife of the American 'Silver King') the flowers were arranged in this star-shape, the center a heart of flame, and the rays shading to the palest tint as they tapered off. The places for the guests are laid just in between these rays; and the effect, as may be imagined, is exceedingly good."

#### A FIGURATIVE DINNER.

"Moore used to speak of a dinner party at Prince Esterhazy's, where he had the honor to 'assist.' All the meats were represented in carved wood, beautifully painted. The guest pointed to the dish he wished for, and servants brought it to him in its real shape."

#### A VARI-COLORED DINNER IN BUFFALO.

While the following in the first place is only amusing it really contains a serviceable hint to those who have artistic pieces to display:

"A gentleman who was invited out to dine at a Delaware residence lately observed that the chandelier over the dining-room table was of peculiar construction so that there was a light over the head of each guest. The globes were of various colors, some amber, some red, and some blue. 'What is the object of having the globes of different colors?' the guest asked of the hostess. 'Why, you see,' said she, 'when one gives a dinner or tea one must invite some people whom one hates. Now, last Tuesday I gave a supper and had to invite two women whom I despise. But I had to invite them or some of the young men I wanted would'nt come. I had my revenge on my fair enemies, however. I placed each of these two women under one of those pale blue lights at table. They're usually considered beautiful women, but under that light they had the most ghastly look you ever saw. They were perfect scarecrows. They seemed to have aged twenty years the minute that they sat down. The men noticed it, of course, but they did not divine what caused it. They

were quite taken aback and awfully glum at first. But finally one of them turned with a sigh and began talking with a real lovely, homely little thing that was sitting under a ruby-colored light. Why, she was perfectly charming under it. So you see that when I want people to look perfectly hideous I put them under the blue lights. It kills everything.' The gentleman looked up. He was under a blue light."

#### A TROPICAL DINNER IN NEW YORK.

"Just before Lent a tropical dinner was given here by a wealthy man. The floral decorations were all tropical plants. For the ferns, palms, ivy, mandarin trees, Florida and Central and South America were ransacked. The truffles were brought from France and a bouquet of ten strawberries was placed before each guest. These cost ten dollars a bunch. The table was arranged around a miniature lake, in which palms, lillies and ferns appeared to be growing, while tropical trees rose from the banks amid miniature parterres of flowers. Small electric lights, with vari-colored globes, were arranged about the lake, and by an unique arrangement electricity was introduced under the water of the lake and caused to dance about in imitation of vari-colored fish. Twenty courses were served. There was no cloth on the table. A beautiful palm-leaf fan was placed on the table before each guest, and on these the plates rested. The individual decorations on each plate cost \$30, while the favors cost as much more, and the menus \$10 each. Roman punch was served in oranges hanging on the natural trees, the pulp of the fruit having been deftly removed so that the favored guests could pick their own fruit. The dinner cost \$175 per cover. The wine and music were extra."

#### FISH DINNERS IN PARIS.

"The Paris 'fish dinners' for Wednesdays and Fridays are especially studied by hostesses to impress their visitors with the

cleverness of their cook, who can serve up a most varied banquet without hurting the most tender devotee's conscience by heretical meats. There is even a churchly touch in the menu, which represents a tiny illuminated missal. Flowers are banished from the table, but foliage of all kinds and tints is equally pretty and more novel for decoration. At dessert the fruits are no longer put on dishes, but served up as if hanging on their own trees, grapes, apples, and oranges being deftly fastened on small shrubs, and the pots being hidden by gold-embroidered plush coverings."

#### FRENCH DINNER TABLE DECORATIONS.

"From information supplied by a Parisian caterer it appears that there are at present four fashionable styles of dinner-table decorations in vogue in the Gay City. These are known respectively as the 'Diner Parterre,' the 'Diner Foret Vierge,' the 'Diner Virtuine,' and the 'Diner Reposeir.' In the first the table is ornamented with little flat silver saucers filled with green moss, in the centre of which is a glass tulip-lamp. In the second the decorations consist of numerous old Dresden china statuettes and similar articles de vertu in porcelain: Cupids, Venuses, Watteau lords and ladies, set here and there singly or in groups or half hidden in clusters of flowers. The object of the Diner Reposeir is to remind one of the simple decoration of the village church on the occasion of the great Catholic festival of the Fete-Dieu. A garland, thick in foliage and composed of roses, violets and ivy, goes round the table. In the centre a large basket containing the same flowers is placed. In the Diner Foret Vierge the decoration consists of a number of silver baskets fashioned in the shape of the bales or hampers in which coffee is shipped from the plantations. These baskets are filled with bunches of orchids tied together with knots of brilliantly colored and variegated ribbons."

#### IMITATING LUCULLUS.

"The fashionable dinner parties in Paris have taken up a new craze—to have all

their principal viands brought from great distances. These *chic* dinners have sterlets brought from the distant Volga, haunch of reindeer from Lapland, a bear ham from the frozen regions of North Russia, and other novelties from other inhospitable and uncomeatable places."

#### ROYAL SOUP.

"Emperor William recently expressed to Grand Duke Vladimir, of Russia, his regret at not being able to get a taste once more of a certain Russian soup, called *ucha*, of which he had been excessively fond on his former visits to St. Petersburg, and the proper recipe for which seemed to be a secret, even to his chief cook. He was pleasantly surprised shortly afterward at having this favorite dish served to him in a masterly manner. Grand Duke Vladimir had quietly sent his cook to Berlin with two enormous live sturgeons, taken fresh from the Volga, this fish forming the essential ingredients of the *ucha*. The difficulty attending this little attention may readily be appreciated from the fact that the sturgeon had to be transported from the frontier of Asia, and that this fish, like trout, has to be kept constantly supplied with fresh water during the transit in order to keep it alive."

#### THE SAME IDEA WITH A PURPOSE IN IT.

"The bill of fare at the banquet which was given at Madrid last week in honor of the anniversary of the discovery of America was an international curiosity in its way. By way of doing 'homage to Columbus' the guests who sat down to dine at the Theatre Royal on the 12th inst. were supplied with the following *menu*: Soup—Isabel, the Catholic and American soup; fish from the port of Palos, from which Columbus set sail on his first voyage to America, *loin à l'Amiral*, Castilian partridge, Andes pheasants, Jamaica punch, roasted Brazilian peacock, Estremadura beans, Havana sweetbread, New York ices, Granada fruit, and Puerto Rico coffee."

FLORAL DECORATIONS AT PRESIDENT  
ARTHUR'S STATE DINNERS.

"The Marine Band was stationed at the large entrance hall and played during the evening, and the apartments on the lower floor were thrown open and decorated. In the East Room the mantels were banked with plants and mosses, and fan and date palms and tropical plants were grouped in angles and window embrasures. Chains of smilax on the chandeliers and mirror frames enhanced the beauty of the apartment. The red, blue and green parlors were similarly decorated with palms and plants, and at the end of the corridor the silver Hiawatha boat, filled with roses, was on an antique marble table.

"The guests arrived before 8 o'clock and were first conducted to the dressing rooms on the upper floors. When all had assembled in the East Parlor the President was summoned, and, descending with Mrs. McElroy, greeted his guests and led the way to the state dining-room with Mrs. Freilinghuysen as the first guest of honor. The state dining-room was appropriately decorated with palms, blooming azalias, and other plants, and the table was ornamented with a large set-piece in flowers, intended as a fanciful representation of the hanging gardens of Babylon. The raised garden overhung the long central mirror which, as a lake with coral grottoes and mossy shores, bore a fleet of tiny boats loaded with roses. The garden, in canopy shape, rose three feet or more from the table and was nearly six feet in length. It was composed of red and white carnations, with banks of Marshal Niel and bon silene roses, set with orchids. At the ends of the mirror lake were tall gilt candelabra, bearing shaded wax lights, and beyond them large crystal bowls, overrunning with long-stemmed roses. Circular plaques of roses, carnations and lillies of the valley flanked by silver candelabra, were at the extreme ends of the table.

"The board was laid for thirty-six covers. Six wine glasses, a water carafe and goblet were at each place, together with the menu

cards and boutonnieres for the gentlemen, and large corsage bouquets of roses or lillies of the valley for the ladies. Sixteen courses were served."

PRESIDENT CLEVELAND'S TABLE. — REVOLVING GLOBE. BASS IN JELLY.

"The centre of attraction in the dining room was the long white damasked table, about which the thirty-eight guests of the evening sat with the President and Miss Cleveland. The gilded central plateau, which ran almost its entire length, had its upright edges twined with smilax, and its central ornament was an immense floral globe fully ten feet in circumference. It revolved under a square support and upright frame, and was set so high that it did not obstruct the view across the table. The land surface was marked by solid clusters of carnations in red, white, pink, and scarlet. The oceans were represented by the lapped leaves of shining camellias, and the bays, rivers, and small streams were marked by tiny strands of smilax. The square-framed support was garlanded in smilax, and above it was a single star in red immortelles. The globe almost rested on a field of bon silene roses, set in a mass of smilax. Two ships rode at anchor on the mirrored surface of the plateau, their hulls made of pink and white carnations. The bow was filled with Catharine Mermet roses, and the stern freighted with Parma violets. The rigging was twined with smilax. Two overflowing gilded vases of Marechal Niel and bon silene roses marked the extreme ends of the table, and flat bouquets the added corners that accommodated four extra guests. A sea bass enveloped in jelly rode proudly in a chariot drawn by sea nymphs, and round fancifully arranged moulds of *pâté de foie gras* were the French *chef's* contributions to the beauty of the table."

FLORAL DECORATIONS AT THE PRINCESS'  
BALL.

"The ball to the Princess Louise and the Marquis of Lorne at the Windsor Ho-



tel in Montreal, brought out the elite, and, as it was the farewell to the Queen's daughter, more than ordinary attention was paid to it. Decorations in the floral way from Boston, the rarest flowers from hot-houses, and all that decorative artists from New York could devise was done to make the ball room attractive. The ball room was magnificent, and, in fact, the Windsor Hotel never looked so gay. The scarlet and black of the infantry and blue and gold of the cavalry and the stately dress black, with the hundred and one shades of silk and satins worn by the ladies, together with the flashing of diamonds, gave the grand promenade a bewildering appearance. Soon after the dancers had entered the room, Princess Louise entered upon the arm of the Marquis, and they took places upon a dais. The Princess wore a white brocade cape overdress trimmed with crimson velvet flowers, a rich diamond necklace and head-dress of diamonds, simplicity itself. She looked very beautiful. The noticeable feature of the ladies' toilet was the absence of low neck and few floral head-dresses, and diamonds were generally worn in their place. There were many celebrities present."

#### TENS OF THOUSANDS OF FLOWERS.

A Boston florist, who was engaged to furnish part of the floral decorations for the Princess Louise ball at the Windsor Hotel in Montreal, had them transported in a special car. There were: 20,000 roses, 20,000 carnations of different colors, 1,000 spikes of tube roses, 500 bunches of violets, 1,000 sprays of heliotrope, 2,000 strings of smilax, and 2,000 yards of English laurel.

#### DECORATED DISHES AT MRS. VANDERBILT'S RECEPTION.

"One piece was a game pie of pheasants, the pie resting on a flat surface of wax, the entire piece upheld with deer's antlers. The sides of the pie were trimmed with quails. Underneath were two rabbits playing cards, while to the side of the players

was a bridge, under which gleamed a lake of water with goldfish swimming about.

"Another was a fruit dish in wax, in which were placed imitation eggs and potted reed birds.

"Another piece was a fillet of beef, with a garniture of vegetables of all kinds resting on the shoulders of a Hercules; on either side were placed some cupids, the figures being of wax and very cleverly executed.

"One of the most artistic pieces was a two-foot salmon, resting in a wax boat, while on the back of the fish sat a cupid; the boat was supported by a Neptune at each end, seated in sea shells and driving sea horses before them in a lake of real water in which fish were swimming around.

"A fine piece was a flying Mercury poised upon a ham, the ham being finely ornamented with a delicate tracing of truffles.

"About midnight the following artistic supper was served:"

#### MENU DU SOUPER.

Consommé en tasse	Huitres à la poulette
Croquettes de volaille	Bouchées à la reine
Terrapin à la Maryland	Canvas-back duck
Galatine de chapon	
Filet de bœuf, jardinière	
Aspic de foie-gras, belle vue	
Chaufroid de mauviettes	Pâte de gibier, chasseur
Pâte de Strasbourg, naturel	
Saumon à la Vatel	Jambon à la gelée
Salade de poulet	Salade de homard
Volière de cailles	Sandwiches varies
Charlotte moderne	
Gelée macedoine aux fruits	Glacés assorties

#### MRS. VANDERBILT'S DIAMOND BALL.

The grandest and probably most expensive ball which ever took place in New York was given by Mrs. Vanderbilt about three or four years previous to the reception alluded to above. It was described as "an Eden of tropical exotics--musical strains from a rose-embowered arbor--flashing diamonds on a sea of silken waves--a supper fit for the gods, fringed by a cataract of wine." The *menu* makes but a small figure in print for an occasion that was reported to have cost \$30,000. But this is it:

The *menu* was engraved in delicate script and printed on a heavy bevelled bristol card, with gilded edges, three and

a half inches wide by five inches in depth. In the centre, near the top, was the Vanderbilt coat of arms in raised gold.

## CHAUD.

Bouillon.  
Huitres frites. Croquettes de volailles.  
Terrapine à la Maryland.

## FROID.

Saumon à la Rothschild.  
Galantine de volaille aux truffes.  
Filets de bœuf à la gelée.  
Jambon à la gelée. Poulet à la gelée.  
Chaufroid de mauviettes.  
Aspic de foie gras en bellevue.  
Salade de volaille au celeri.  
Mayonnaise de homard laitues.  
Sandwiches à la Windsor. Pain de Rilette.  
Baba au rum.

## GLACES.

Napolitaine. Biscuit glacé.  
Merveilleuse. Diable rose.  
Vanille.

[*Translation of the above menu.*]

## HOT.

Bouillon.  
Fried oysters. Chicken croquettes.  
Terrapin, Maryland style.

## COLD.

Salmon à la Rothschild.  
Boned fowl, truffled.  
Fillet of beef in jelly.  
Ham in jelly. Chicken in jelly.  
Chaufroid of reed birds.  
Aspic of foie gras en bellevue.  
Chicken salad au celeri.  
Mayonnaise of lobster and lettuce.  
Sandwiches à la Windsor. Rilette bread.  
Baba au rum.  
Five varieties of ices.

## THE PROGRESSIVE DINNER NOVELTY.

"The progressive dinner has leaped at one bound into popular favor. This new freak of New York festivities imposes on each guest of the masculine persuasion the duty of moving at the end of each course one seat to the left until he has completed the circuit of the dinner table, tarrying for a brief period at the side of each lady of the party. When he has safely completed the hazardous voyage and has steered once more into the haven of refuge provided by his first love, there he may rest till the chairs are pushed back and a final adjournment taken. A much more careful choosing of guests to harmonize each with all is sure to be the result of this last of fashion's mandates, so a woman who has obeyed it tells me, if the notion of the week is to endure even for a fortnight, for a single discordant note mars the effect of all. Any

sandwiching in of dull folk or prosy folk is sure to be revealed in this puss in the corner game."

## THIS LADY HAD A NEW IDEA.

"Recently Señora Romero, the wife of the Mexican Minister at Washington, gave a special afternoon reception, at which Mexican chocolate was made by a Mexican girl before the company. The girl, who was unable to speak a word of English, is a member of the company of Mexicans now here who have recently established the unique show, the Mexican village. On a square table in front of the girl was a native charcoal stove of red earthenware in the shape of a gentleman's hat, and called by the Mexicans 'brasero.' A half moon cut in what would be the top of the hat furnishes the necessary place for a draught to keep the coal above near the brim warm and glowing. The chocolate, which is in large cakes, is then finely broken into an earthen jar, on one side of which is a handle. Into this jar is then put cream, sugar, and the white of egg and cinnamon, which are mixed by a small instrument resembling a churn-stick, which the girl moves rapidly between her hands by rubbing them together. The compound, which in appearance resembles the chocolate ordinarily prepared, is thoroughly heated through by being placed on the glowing coals in the earthen jar in which it is made. From this it was transferred to the silver urn on the dainty spread table, and served by the young ladies presiding."

## COULDN'T "CALL OFF" THE ENTREES.

"The Greek consul in Boston is an honored and esteemed member of the New England Club, who sit down to a pleasant little family gathering at Young's every Saturday afternoon. Yesterday happened to be his birthday, and the president has been engaged in devising a little surprise, not only for the genial consul, but for the whole club. It had been announced that 'Greece' was to be the subject of the weekly discussion, but when the members

arrived at Young's yesterday afternoon, and, after exchanging greetings, sat down around a well laden board and took up the *menu* cards, their faces at once assumed a puzzled look, which gradually gave place to expressions of utter despair or broad gleams of fun. Then the waiters appeared, gazed at the bills helplessly and hopelessly, and retired for consultation. The entire bill of fare was printed in Greek. There were long words and short words, and whole strings of hieroglyphics, which ambitious members vainly sought to translate into the nomenclature of the modern *cuisine*. At last one member cut the Gordian knot by summoning a chuckling waiter and boldly ordering 'some of No. 1.' Others followed suit, and so the whole list of goodies was disposed of amid much hilarity and many earnest discussions as to whether 'No. 6' was ever better, or whether any member in his whole experience ever remembered a time when 'No. 3' or 'No. 7' tasted so good to him as on that particular occasion. Ex-president Folsom, not fully satisfied by the course arbitrarily prescribed by the bill of fare, varied the monotony by demanding 'Socrates hash,' and was loudly seconded by another member who wanted 'Acropolis beans,' and yet a third who declared for 'ham and eggs à la Diogenes.' "

#### THE SAME THING ELSEWHERE.

"One of the most curious menus ever issued to guests was that arranged by the members of the British Medical Association and served at the Ship Hotel, Greenwich."

The entire bill of fare was printed in the newspaper—it was a large one, containing many courses, and every word and heading was printed in Latin.

#### NOTIONS IN SILVER.

"Among accepted novelties in dinner giving in Paris must be mentioned the now general fashion of much silver bric-a-brac upon the tables. To each guest a tiny silver salt cellar, of a different shape to each cover. This in the shape of a mar-

mite, this of a saucepan, that of a shell. Also at small familiar dinners to each guest a little butler dish, also of silver, in a fanciful shape and a tiny knife thereto—an excellent addition to a table when oysters are served, and pretty withal, also appetizing with the ice-spangled pat of yellow butter in the silver shell. Still at the 'diner intime,' in front of the host the mustard pot, the pepper mill. Yonder a silver pickle jar. The table should resemble a children's feast. Lilliputian trifles everywhere. Candles are much used now, with tinted shades, in silver candlesticks."

#### THE VIENNA COFFEE FASHION.

"The latest agony in silver table decoration is a very large platter with a swan at one end. On this coffee cups are placed, with a cream jug and sugar bowl. The latter should be of Saxon manufacture to be entirely correct. The huge swan, with its outstretched wings and curved neck, is in reality a coffee pot, which the hostess can swing on and off the platter to serve the fragrant beverage, lifting each time the delicate throat of the bird. It is an old Louis XV. model rejuvenated and a trifle modernized."

#### DIFFERENT CHINA FOR EACH COURSE.

"A few years ago the dinner set signified every piece used upon the table from the soup set to the after dinner coffees, but fashion has changed all this and the different courses are much more effectively served with dishes contrasting in color and ornamentation. Very little extra expense is involved in this change, as some of the china or porcelain fish sets, soup, game or oyster sets, with neat dessert and fruit sets of the most artistic shape and decoration, can be had at a very small price compared with that of a complete set a few years ago. Oyster sets are really not essential, yet it is very nice to have them. The half dozen oysters may be served upon any dinner plate with a bit of lemon in the center and should be upon the table when

dinner is announced. A handsome soup set adds much to the table, but fish may be served upon any dining plate that can be heated. A fish set showing designs of salmon or trout strung upon hooks or in the meshes of a net or from a forked stick is certainly not a very appetizing sight. The potato dish should be in harmony with the fish service, whether it be plain or decorative. Glass dishes may be used for olives, pickles or cucumber salad, which is very nice served with fish. These may remain on the table during the entire dinner.

“Meats should not be served on plates fancifully painted, a border only being in better effect. Dinner plates, meat platter and vegetable dishes should be alike, and although the coffee cups must be the same size or shape, they may exhibit different colors and ornamentations. Haviland porcelain is among the elegant table ware, and its value is according to the decorations, which are from the finest landscape painting to the quaintest genre. Minton china shows a white ground with floral designs vined and edged with gold. The Danish porcelain, which is especially adapted to dessert sets, shows the edges open. The low, wide amber glass finger bowls are fashionable and pretty, and those in other styles and the elegant cut glass bowls are often selected by the wealthy.”

#### CANDLES AND GLASS SHADES.

“The candle on the dinner table holds its place still. The latest device that the art ware establishments have contrived for its adorning is a sliding scale that falls imperceptibly as the candle burns lower. The shade is made in the simple Bohemian glasses, in decorated art glass of every description, and is sometimes seen in rare jewelled glass in every rich, soft hue. The shaded candle sheds over table furnishings, flowers and faces of the guests the very perfection of light that the dinner givers have looked for these many years in vain.”

#### NOTIONS IN ICES.

“At a Cinderella ball the ices, of the *biscuit glacé* form in paper cases, each contained a gift, either a small coin, a tiny thimble, a ring, or some of the pretty toy-like patterns in silver broches and watch charms, cornelian hearts, sparkling flowers in jewelry, all of the smallest description. The gifts were wrapped in transparent caramel paper and pushed down at one side of the ice, and the outside of each case bore a motto. Handsome flower-bordered cards, with written quotations from the poets, were attached to the spoons, which with the plates were selected by the young ladies and young gentlemen for each other in turn.”

#### CHANGING DECORATIONS FOR EACH MEAL.

One of the British princes was recently entertained at the country seat of a nobleman at a “hunt breakfast” and dinner, and the decorations and table ware were changed for each as follows:

##### HUNT BREAKFAST MENU.

Broiled Kidneys.	Pulled Fowl.	
Salmon Steaks.	Stuffed Tomatoes.	
Sheeps Tongues.	Potted Pigeons.	
Broiled Rump Steaks.	Qunelles.	
Croquettes of Rice and Ham.	Chickens in Bechamel.	
Potted Game.	Pâte Mêlé.	
Cold Sirloin of Beef.	Pressed Tongues.	
York Hams.	Raised Pies (various).	
Normandy Pippins.	Stewed Prunes.	
	Clotted Cream.	
Roast Snipes.	Woodcocks.	Trushes.
Apple Marmalade.	Apricot Jam.	Currant Jelly.
Vanilla Milk.	Café au Lait.	Tea.
	Liqueurs.	

“The tables on this occasion were dressed with white cloths and decorated *à la jardinière*. The silver antique jardinières were filled with ferns and spring flowers, peeping out of mosses of various kinds. *Large silver bowls* and epergnes on the side-board and side tables were filled with exquisite arrangements of hyacinths, tulips, wood violets, snowdrops, etc., in mosaic patterns; whilst hanging baskets graced the windows, filled with the spiritulle cyclamen light foliage, interspersed with yellow and red flowers, that gave the grand old oak hall a splendid appearance. The *display of antique plate* would have delighted the

heart of the most enthusiastic antiquary, and the *tout ensemble* seemed to give the young prince much pleasure.

"The vanilla milk, which, by the way, was half cream, found great favor, and was served steaming hot in silver cups. Some added curaçoa to it, others a *petit verre de Cognac*, but the majority preferred the sweet beverage simply as prepared in the kitchen by my worthy old friend, the *chef*, who is too modest to allow me to give his name."

The dinner *menu* was as follows:

MENU.

SOUPS.

Vermicelli. Mulligatawney.  
 Salmon, Fennel Sauce.  
 Boiled Cod, Oyster Sauce.  
 Poulet à la Albert Victor, Mushroom Sauce.  
 Pigeons à la Zetland, Madeira Sauce.  
 Veal à la Piedmontese.  
 Blanquet de Mouton.  
 Roast Sirloin, Hors-radish Sauce.  
 Turkey, Sauce Athenian.  
 Asparagus en Croustade. Artichoke Fritters.  
 Bondon Cheese à la Diable.  
 Apricot Pudding. Devonshire Clotted Cream.  
 Bread and Butter Pudding, Wine Sauce.  
 Salad. Dessert.

"The room was decorated with palms, choice tropical plants, and exquisite exotic flowers, *forming a complete change to the morning decorations*. The band played in an ante-room adjacent, which was curtained off, and also profusely decorated with mirrors and floral beauties. *The dinner service was of very handsome old china*, the floral decorations on the table were laid in the Oriental style now so fashionable."

A BOATING CLUB'S FANTASY.

"The table was decorated with glass ware in the shape of small boats mounted on plateaux of looking-glass, surrounded by sage-green plush borders, fringed by silk blond lace of a lighter shade. The boats rested on four glass oars, crossed at either side, and forming a stand. Light trailing foliage depended from the boats, and trailed on the glass plateaux. Spring flowers from the sunny South filled the boats and nestled amidst ferns and mosses arranged round the gunwales. At the prows of the larger-sized *bateaux* were little flags and

ensigns. Small glass boats were laid at each cover, filled with dark-blue violets and French or Italian grown forget-me-nots in alternate boats. The violets for the gentlemen, the light-blue flowers for the fair visitors. The *menus* were printed on cards representing a yacht's sail, silver-edged and supported at the back by an oar, which fixed the card easel-fashion. The napery was folded *a la bateaux*, and the gunwales formed of violets, snowdrops, and primroses, intertwined with light foliage and mounted on wire, so that they were readily removed by the guests and kept in form without the untidy litter often caused by the insertion of loose sprays in the serviettes. In the centre of the table was an epergne filled with fruit and flowers. In the middle of the large glass dish, on the top, was an Undine boat, filled with flowers, and an exquisite wax model of Undine, the water spirit, in their midst. The boat was surrounded by fruits and flowers of the most expensive class, intermixed with young palm-leaves and natural grasses. At the foot, beside the claws (representing four lions *couchant*), were groups of little sailor dolls, representing the crews and their friends, no doubt, some with small polished oars, others with flags, and a couple with flagons in their hands. The *tout ensemble* was very pretty."

SCENE PAINTED BALL SUPPERS.

"The buffet was shaped in the convenient horse-shoe style, and dressed with the usual holly, mistletoe, bay, laurel, and rosemary; also a goodly show of chrysanthemums and hot-house flowers—the latter arranged in baskets. A plentiful supply of French-grown feathermoss, sent in boxes, was a wonderful help to the buffet dressing. One feature of the decorations must not be forgotten, and it is a point that caterers would do well to insist on being adopted, as it is good for trade and a real boon to the guests. I refer to the *coterie* nooks in the ball-rooms, ante-rooms, and conservatories. In this case they were *replicas* of a moonlight scene. The land-

scape painted in distemper on canvas at the back. The moon, full or crescent, let into the canvas and made of oiled paper, and a lamp hung behind; a bed of moss reached slantwise from the scene to the ground; chairs and 'sociables' were placed amongst palms, shrubs, etc. Fairy rings were made of mushrooms (edible ones, too, for they were formed of sugar-work); in the moss, and at a square coterie table, stood a neat-handed Phyllis, with pins, needles and threads, perfumes, and a light array of light refreshments—ices, sherry, champagne syphon, and aerated waters; also plain iced water, *eau sucre*, and fruits. It saves partners leaving to rush to the *salle-à-manger* in search of ices, wines, etc., for their lady friends, and if slight accidents occur to the pretty, fairy-like or gorgeous toilets of the fair dancers, they are soon repaired without the inevitable withdrawal to the cloak-room. Fairy lamps, in wreaths, and peeping out from the foliage, completed most harmonious scenes."

#### SEA CAVERNS AND FAIRY GROTTOS.

"At Lord X's, one of the wealthiest peers of the realm, great preparations are being made for the coming of age of the heir. He was a veritable Christmas box to his family, being born on boxing-day, and the festivities are to be of quite an elaborate character. There are to be two supper rooms—one Oriental and the other a representation of ocean caves. The latter is a wooden building thrown out from the piazza leading from the dining-room windows, and taking the whole area of the three windows and the lawn. This hint as to mode of decoration may be useful both to restaurateurs and caterers. The caves are formed of cork, whitewashed, and then brushed over with a solution of Epsom salts and permitted to dry; this forms crystals, and is mixed with other pieces of cork finished by being dusted whilst wet with ground glass. Glass dust is procurable at a very cheap rate from the glass works. These pieces of cork, when finished, are to be nailed to the roof and

sides of the room, and pots of grass interspersed amongst the wall decorations. Coke coated with whi'ewash for the ground. Gas jets with reflectors of glass mounted on discs with red, green and white tinfoil at the back will be grouped so as to give quite a fairy-like beauty to the scene; and one large electric lamp will be placed in the wooden building, the same machine supplying the electricity as that used for the ball room. This, by the way, is a continuation of the central hall, which acts as reception and crush room, and for the buffets of ices, claret and champagne cups, etc."

#### A SEA SHELL DINNER.

"The host has a favorite hobby—conchology—and a most superb collection of shells, corals, and algæ, and the caterer pressed the whole into his service, and turned out what the hostess was pleased to term 'one of the most beautiful and novel table-dressings she had met with;' and her experience is wide.

"The huge masses of white, pink, and smaller clusters of red coral were disposed of down the centre of the table, seaweeds (dried, of course) clustering around their base. Chrysantemums—white, red, yellow, etc.—and their smaller brethren, the pompons, were arranged in groups on rocks to resemble sea-anemones, and in clusters on the base of the corals. Star-fish and similar crustacea were of the greatest service. In the fountains and at the foot of the flower vases was a plentiful supply of gold and silver carp.

"There was not nearly enough coral branches for the design, so imitation clusters were formed by making wire frameworks, wrapping them evenly and regularly over with soft-finished hank darning cotton; then melting vermilion and pale yellow wax and dipping in the clusters. The separate groups required to be suspended by wire and to be dipped in when the wax is a little cool, then allowed to hang with the points of the sprays downwards. When nearly set, have a few fine

needles or pins set in a cork and prick the whole surface of the wax over, so as to imitate the cells in the larger coral growths. Large clam shells, one nearly  $\frac{3}{4}$  yard across, served as flower vases, whilst their smaller polished *confrères* of the sea, nautilus and cup-like bivalves, made excellent fruit-stands, in groups of three between each guest.

"They used a species of fairy-lamp, mounted on electro-silver stands, shading from pale yellow to deep orange, from pale blue to a very delicate Alexandra tint, and rose to damask. These in two and threes, with nautilus shells between, filled with delicate white sprays, gave a subdued and beautiful softness to the whole of the table decorations. Nougat shells and rockeries helped out the *mise-en-scène*. Nor must I forget the mermaids, made from dolls' heads having long fair hair, and finished with fish-tails formed from wax, and tinted as one would shade wax flowers or fruit. The colors were laid here and there on silver and gold leaf, so as to shade from silver white to lead or steel grey, and from gold to deep orange yellow. A traditional looking-glass and coral spray as a comb completed the toilet, according to our Aytoun's old ballad:

'For aye she cambed her yellow hair,  
And syne she sang sae sweet.'

Only, the dolls did not sing; but the string band in an adjacent chamber discoursed some very fine music, classical and otherwise, instead of the siren's song, which no doubt the guests appreciated highly."—*Cordon Bleu in the British Baker, Confectioner and Purveyor.*

#### A WEDDING BANQUET.

The following is the *menu* of a wedding banquet served at the Southern Hotel, St. Louis. Covers were laid for one hundred and fifty persons. It was quite a swell affair, the contracting parties being Mr. Johannes Kluchu, of Hamburg, Germany, and Miss Gustana Busch, daughter of Mr. Adolphus Busch, the great St. Louis lager beer brewer. The *menu* card, tied with

blue favors, was an artistic production in the form of two hearts, and was much admired for its elegance and novelty:

Consommé en tasses.  
Pâtés aux huîtres. Sliced tomatoes. Cucumbers.  
Pompano. Potatoes, Duchesse.  
Haut Sauternes.  
Tenderloin of beef, aux truffes.  
French peas.  
Château Bouillac.  
Terrapin, à la Maryland.  
Amontillado sherry.  
Punch à la Romaine.  
Bride's cake.  
Snipe au cresson. Fresh asparagus.  
Mumm's extra dry.  
Charlotte Russe. Assorted cakes.  
Veuve Cliquot.  
Roquefort cheese and hard crackers.  
Ice cream. Fruits. Coffee.  
Apollinaris water.

#### GRAND WEDDING RECEPTIONS.

"In the first place it is necessary, when receiving the order for the 'wedding collation,' to *see* the premises. The confectioner, *chef*, or contracting party *must* view the rooms. The shape of the drawing room or grand hall decides where the bride and bridegroom are to receive their guests.

"The parents of the 'happy couple' stand at the entrance of the room and receive the visitors as at a ball. The guests then pass on to the top of the room where a small raised dais is usually erected, covered with crimson cloth and snow-white wool or hair rugs. The bride is surrounded by her bridesmaids and pages on the left-hand side, and the groom by his best man, etc., on the right. The dais, chairs, steps, etc., are decorated with garlands of beautiful white flowers, such as edelweiss, azaleas, roses, stephanotis, jessamine, myrtle, violets, picotees, nicotiana affinis, stocks, liliuncandimum, narcissus, hyacinths, bouvardia, etc., etc., which are all available, and, being pure white, are used, not only for the reception platform, with its orthodox three steps, but also for the stand or table on which the cake is placed to the left of the bride's platform; and the wedding present table on the bridegroom's right hand. If the presents are very numerous, boards and tressels are used, covered with velvet or plush and lace, generally guipure, to match the round or oval table on which the cake is placed. A

bow-window, an alcove well lighted, or, if a square room, I have seen the hearth used for the reception, whilst a perfect bower of flowers, delicate ferns, and feathery green foliage was made over the pier glass, on the surface of the mantle slab, in the grate itself, and wreaths entwined like lattice work depended from the corners of the mantelpiece to the foot of the dais.

"A crimson cloth leads from the door to the reception platform. It throws up the beauty of the bride's white dress, and should it be a widow remarried, with a lavender-gray dress, the effect is equally rich and beautiful. The two chairs, used during long receptions, are generally gilt, covered with crimson Utrecht velvet, preferably, as being a dead color resting against the ivory satin or repp silk of the bride's dress. If a white velvet train is worn, the caterer must have repp chairs, so that the contrast may be perfect. He has all this to consider and arrange.

"Now for the *Salle à Manger*. Everything that is admissible at a high class ball supper is required here. The people who only offer sandwiches are 'enough to make a fellow wild,' as Johnny Toole has it, and they are decidedly not *bon ton*, even if they offer their guests the forty varieties noticed by 'En Route' on Lang's celebrated buffets. But *à nos moutons*. If more than one hundred guests are to be arranged for, form the buffets round three sides of the room, in the horseshoe shape, it will please the bride and her mother, the feminine deities of a household being peculiarly superstitious, deny the soft impeachment, if they can? But to the caterer these corners are useful. Raise a screen across each angle, pile virgin cork to imitate rock work, also mosses, grasses, ferns, and flowers against it. They make nice places for your 'wash-ups,' and the storage of an ice safe or two, relays of pastry, fowls, etc., etc., and for urns of the larger size with tea, coffee, etc., which if near the displayed ices and jellies might do serious damage. At all fashionable and *à la mode* weddings there are two bride's cakes. The *major* or best cake in the

drawing room and the *minor* in the refreshment room. From forty to fifty small tables are arranged with four seats to each, menu cards form the centre-piece. The prettiest I have seen were triangular, of white porcelain, headed with a cupid perched in a tree, and a slim fair maiden in robes of white, with cornflowers in her Leghorn hat, standing in a very *pre-Raphaelite* field, with one of the archer god's darts in her breast and her hand on it. Whilst an Adonis of, I must confess, rather dusky hue, and curly hair, was issuing from behind a tree. By the way, I may as well here give the

#### MENU.

- Caviare noir. Caviare de Norwége.  
Huitres.  
Paté de foie gras.  
Galantine de tête de veau.  
TERRINES (Potted meats).  
Terrines de leveret.  
Et perigord, bœuf, faison, etc.  
Mayonnaise du saumon.  
Mayonnaise verte, blanc et jaune.  
Andouillettes, vol au-vents de crème de poulette.  
Crème de veau, etc.  
Godivaux et quenelles.  
Langue de bœuf glacé. Bœuf rôti et garni.  
Poulettes. Jambons de Yorke.  
Dindon rôti et en galantine, chevreuil rôti.  
Paté de venaison. Paté de faisan.  
Faisan rôti. Faisan à l'Indienne.  
Mayonnaise de perdreaux. Paté de perdreaux.  
Florentines de lièvre. Trophée de bécasse.  
Paté de bécasse. Pluviers en broche.  
Ortolans en aspic. Cailles en aspic.  
Aspics de poisson, de pigeon et de legumes.  
Pâtés des gibers. Salades.
- PÂTISSERIES.  
Puits d'amour. Meringues. Nougats. Gateaux.  
Creains. Jellies. Ices, etc.
- WINES.  
Champagne. Claret cup. Port. Sherry.  
Chablis. Liqueur d'Or. Liqueur chartreuse.  
Maraschino. Noyeau, pink and white.  
Punch and loving cup.  
Fruits, fresh and dried. Tea. Coffee, etc.

"The arrangements of the buffet are in this wise. In the centre of the horseshoe table is the wedding cake, ornamented with a wreath of natural *white* flowers and green foliage of a light character round its base. The various tiers are dressed with groupings of designs in sugar work, showing forth some Shakespearian love story; Tennysonian idyll; or groupings of historic scenes from the family history. The edges are piped in white, and the wreaths *on* the cake are of sugar work. If natural flowers are used they are not placed *on* the sugar



work or icing direct, but in delicate vases, and the stems wrapped in damp cotton wool, as no water must touch the icing, and the flavor of flowers and plants do not add to the *gout* of the cake's icing. There are usually stands of three tiers about four feet long, draped in crimson or pale blue sateen with lace valances, on which rest the lighter pastries, jellies, creams, etc., interspersed with groups of many-hued flowers in pots, together with bouquets, and stands of cut exotics, *épergnes* of fruits. Trophies of game, fowl or sweets rests on the buffet itself, whilst between the four-foot tiers spaces are left where, behind the buffet, the carvers, in their spotless white dress and caps, are to be seen busily engaged, and their assistant servers, neatly dressed young women, handing the plates to the army of well-trained servants and waiters attending to the guests, who group themselves at the small tables or sit down at a long dining table in the centre of the room.

"The rage just now is to have a high-class string quartette band playing really good chamber music, and not a few of dear old Abbé Lizzt's pieces, Mendelssohn's songs without words, music from the Midsummer Night's Dream, selections from Flotow, Gounod, etc., find their way into the programme of sweet sounds. The cake in the *Salle à Manger* is not supposed to be cut till the bride's parents or sisters send it out to their absent friends and relatives. To dream on, eh? It is the cake in the reception room that receives the honor of distribution, and is partaken of with light wine at the reception."—*Cordon Bleu in British and Foreign Confectioner*.

#### WEDDING BREAKFASTS, AND THE PRICES CHARGED.

[From the *London Caterer*.]

Lent will soon be over, then comes the time when so many marriages are celebrated, and as it has now become much the fashion to hold the wedding breakfast at some good hotel, I think it just possible I may be able to give some useful hints to

the inexperienced hotel keeper by publishing *menus* of a few of the many wedding breakfasts I have had prepared, together with a short description of the table arrangements, number of guests present at each, and the charge per head.

#### MENU NO. 1.

Consommé à la Victoria.  
 Aspic of Prawns. Lobster Salad.  
 Roast Fowls. Cumberland Ham.  
 Roast Lamb. Pressed B. ef.  
 Swiss Cake. Fruit Jellies.  
 Strawberry Cream and Lemon Water Ices.  
 Dessert and Bonbons.

The above, as will be seen, was a very simple breakfast, as we were restricted to price, 7s. 6d. (\$2.00) per head, including half a pint of wine to each person. Sixteen sat down. The table, a long one, seating seven persons on either side and one at each end, was laid in the ladies' coffee-room (kept private for the day), and was prettily decorated with a border of flowers, about one foot wide, just inside the plates; opposite the latter were sixteen rustic branches rising from the flower border, to support the *menus*, which were printed in silver on a white ground. A small cake, sent by the bride's parents, was in the centre. The table-napkins were folded like tents, the bridegroom being an officer in the army.

#### MENU No. 2.

Consommé à la Nelson.  
 Mayonnaise of Salmon. Lobster Patties.  
 Lamb Cutlets and Green Peas.  
 Capons Béchamel à la Belle Vue.  
 Galantine of Veal. Game Pies.  
 Italian Salad.  
 Wine Jellies. Velvet Cream.  
 Charlotte à la Parisienne.  
 Chocolate and Strawberry Ices.  
 Dessert and Bonbons.

The above was served for twenty-four persons at 10s. 6d. (\$2.50) per head, including a pint of wine for each person. The table, a long one, was laid in the ladies' coffee-room, kept private as before. The cake, a very high one, was sent in by the bride's friends. The bridegroom being a naval officer, we decorated the table with little satin flags, suggestive of a ship on some great holiday. From the cake (forming the centre or highest mast) depended twenty-four silk ropes, on which were threaded the tiny flags. These were ter-

minated by a china figure of a sailor boy holding the *menu* to each guest. The *menu* was very pale blue, printed in a deeper shade. The table-napkins folded like boats, and the most beautiful sea-weeds were mixed with the flowers. The effect was charming and gained me warm approbation from those who gave the breakfast.

*MENU No. 3.*

Palestine Soup.  
Pâté de Foie gras en Aspic.  
Croustade de Ris de Veau.  
Mutton Cutlets à la Princesse.  
Lobster Salad.  
Petits Poulets bouilli à la Crème.  
Pâté à la Parisienne.  
Poulet Rôti. Quartier d'Agneau. Quails.  
Crème aux Fraises. Gelées.  
Pouding glacé à la Nesselrode, Iced Gooseberry  
Fool, Dessert, and Bonbons.

The above was served in the general coffee-room (kept private for the time). Thirty sat down. Charge, 12s. 6d. (\$3 00) per head, including pint of wine. The table was T-shaped, a short table being placed at the upper end of the longer one. The cake, supplied by bride, was in centre of the long table, and the decorations were flowers in low, flat dishes, placed entirely round the principal joints, etc., and little china figures of children holding a small bouquet in one hand, the *menu* in the other, to each guest. The table-napkins were folded like a letter, held together by a silvered quill pen, *menus* the same, the bridegroom being a solicitor.

*MENU No. 4.*

Oysters. Nouille Soup.  
Aspic of Lobster.  
Filets of Soles in Savoury Jelly.  
Filets of Chicken, Tartar Sauce,  
Galantine of Veal. Boiled Fowls with Truffles.  
Roast Chickens. Ox Tongue. Pressed Beef.  
Partridges. Black Game. Grouse.  
Chartreuse of Fruit. Cold-water Jelly.  
Neapolitan Cakes. Fanchonettes.  
Compote of Peaches. Trifle.  
Apricot Cream and Orange-water Ices.  
Dessert and Bonbons.

Forty-five sat down to the table. Charge, 15s. (\$3.75) per head, including pint of wine to each. Long table, same as Nos. 1 and 2; but in addition to the cake provided by the bride's relations, and which formed the centre, we had six very handsome silver *épergnes*, and the flowers were festooned right down the table, the cake and

*épergnes* forming the supports. A pair of tinted doves were placed before each guest, one holding the *menu* in its beak, the other a few choice flowers. Table napkins folded like a large Lily of the Nile.

*MENU No. 5.*

Consommé à la Princesse. Purée à la Reine.  
Homard à la Victoria.  
Cailles farci aux Perigord.  
Mayonnaise de Volaille aux Olives.  
Timbale de Pigeons à la Gelée.  
Suprême de Volaille à la Jardinière.  
Petits Bouchés aux Huitres.  
Côtelettes d'Agneau aux Cocombre.  
Langue de bœuf d'écarlate. Poulet rôti aux Cresson.  
Darne de Saumon à la Montpelli r.  
Pâté de Gibier. Poulets bouilli à la Béchamel.  
Quartier d'Agneau. Dames d'Honneur.  
Compôte d'Orange. Gelées à la Royal et d'Or.  
Genoise Glacé. Crème aux Pafait d'Amour.  
Eau d'Ananas. Crème aux Fraises.  
Dessert and Bonbons.

Fifty sat down to the above. Charge, 17s. 6d. (\$4.25) per head, including pint of champagne to each person. The table was laid in the table d'hôte room, and was most beautifully decorated with flowers and many valuable articles of glass and plate lent by the families of the bride and bridegroom. Noticeable amongst these were fifty silver ornaments, including cupids, shepherds and shepherdesses, doves, and other birds, for holding the *menus*, which were of white satin, printed in bright blue, but very small type. Table-napkins folded in various shapes, so as to hold a small bouquet of flowers.

*MENU No. 6.*

Potage aux Huitres. Consommé à la Royal.  
Salade d'Homard Monté.  
Pâté de Foie Gras à la Gelée.  
Suprême de Volaille aux Truffes.  
Pâté de Gibier à la Strashourg.  
Ronlades braisé à la Royal.  
Mayonnaise de Saumon à la Montpellier.  
Petits Poulets aux Champignons. Quails.  
Gateaux à la Lorne. Meringues au Café Mocha.  
Gelées aux Ponche et d'Or.  
Fanchonettes à la Crème.  
Chocolate Cream and Cherry Water Ices.  
Dessert and Bonbons.

The above was for twenty persons. Charge, 21s. (\$5.00) per head, including pint of champagne to each person. This was served in a large private sitting-room, T-shaped table, charmingly ornamented with twenty little arches formed of flowers, under which stood a little alabaster figure, holding the *menu* opposite each guest. Arches were also formed over the principal

dishes, these being surmounted by tiny white and red satin flags, bearing the united monograms of the bride and bridegroom. The effect was exceedingly good, and gained a deal of praise.

MENU No. 7.

Potage de Gibier Clair.  
 Petits Croustades aux Huitres.  
 Choux froid de Perdrix aux Truffes.  
 Côtelettes de Mouton à la Provençale.  
 Salades d'Homard à la Victoria.  
 Mayonnaise de Volaille aux Pois.  
 Poulet aux Meriton. Jambon à l'Ecarlate.  
 Langue de Bœuf Monté. Petits Poulets rôtis.  
 Bœuf Braisé. Coq de Bruyère.  
 Baba à la Polonaise. Lonidor de Raisins.  
 Veuille a Comfiture. Gateaux de Savoie.  
 Vanilla Cream and Currant-water Ices.  
 Dessert, Bonbons.

The above was served for eighteen at 21s. (\$5.00) per head, including pint of champagne for each person. The table was a long one, with cake in the centre. Its entire surface was covered with flowers in low flat dishes between the different viands. The napkins were folded like artichokes, every fold being filled with flowers, so that each napkin looked like a bouquet. A miniature sword and gun were crossed and placed upright before each guest, so as to support the *menus*, which were silver laid, made in the form of a shield, and printed in bold red type.

MENU No. 8.

Soup à la Reine. Asparagus Soup.  
 Salmon, Sauce Hollandaise. Filets of Soles.  
 Oyster Patties. Quenelles of Chicken.  
 Escallopes of Lark. Leveret Cutlets.  
 Truffled Turkey. Russian Tongue.  
 Roast Lamb. Spring chicken.  
 Pigeons in Jelly. Terrine de Foie Gras.  
 Quails. Lobster and Italian Salads.  
 Smali Pastry. German Tart. Fruit Jellies.  
 Vanilla Creams. Ice Pudding.  
 Dessert and Bonbons.

The above was served for twenty-eight persons at 25s. (\$6.00) per head, including a pint of champagne for each. The table was a large square one, formed of four smaller ones placed together, so as to seat seven at each side. The cake, a very large one, was placed in the centre, and a sloping bank made all round to come about eighteen inches on to the table. From this raised bank twenty-eight festoons of flowers depended, each terminating opposite a guest, and finished by a little cupid holding the *menu*, which was white satin bordered with

a row of small pearls. The effect was charming, and, indeed, the table was photographed for its beauty and the photos sold locally, the bridegroom being a public man and popular in the neighborhood.

In *all* cases the entire service was of white china. The waiters wore white gloves during the breakfast. Crimson cloth was laid on the front steps and down to the carriages. A large drawing room was set apart for the guests to assemble in before breakfast, and bedrooms allotted for the ladies and gentlemen to leave their hats, cloaks, etc., etc.

I made a point to have everything ready long before the time required. All the dishes decorated the last thing with *fresh flowers*. Plenty of ice on the table, and a sufficient number of waiters (allowing one to five guests), with extra hands to carry to and from the rooms. No talking allowed amongst the servants, and a good supply of extra cutlery, glass, cloths, and anything else that might be wanted. Probably in attention to these details may be found the chief reason why these entertainments passed off so successfully as they did.

SOMETHING ABOUT THE COST.

"A dozen big suppers have been given this winter at a cost of \$50 per person. The flowers at the famous Vanderbilt ball cost \$12,000. The roses for Mrs. Bradley Martin's dinner and cotillon cost \$15,000. One hundred guests sat down to the dinner. It cost \$75 per person, inclusive of the flowers and the favors. The Livingston ball and supper in Delmonico's in January cost \$30,000.

"A dinner was given the other evening in one of the highly decorated apartments of an uptown hotel that cost \$75 per plate. Nine guests sat down to this feast, which was worthy of Lucullus. Hand-painted menus, worthy of preservation as works of art, cost five dollars each. The cigars were specially imported from Havana with a brand prepared for the occasion. Many of the wines were specially ordered."

TEN DOLLARS PER PLATE.

Press Club banquet at Delmonico's; 250 plates at \$10.00 per plate, including wine:

MENU.

- |                      |                                   |
|----------------------|-----------------------------------|
| Sauternes 1re Sherry | Huitres Potages                   |
|                      | Consommé à la Douglas             |
|                      | Bisque d'Homards                  |
| Varles               | Hors d'Œuvres                     |
|                      | Timbales à la Reine               |
| Sauternes 1re        | Poisson                           |
|                      | Saumon de l'Oregon à la Nantaise  |
|                      | Pommes de Terre Persillade        |
| Pommery sec          | Relevés                           |
|                      | Filets de Bœuf à la Montebello    |
|                      | Choux de Bruxelles                |
| St. Julien Superieur | Entrees.                          |
|                      | Poulardes Braisées à la Lyonnaise |
|                      | Croquettes de ris de veau         |
|                      | Petits pois au buerre             |
|                      | Haricots verts                    |
|                      | Sorbet a l'Imperial               |
| Macon Veaux          | Rôti                              |
|                      | Canvas-back Duck                  |
|                      | Salade de Laitue                  |
|                      | Entremets de Douceur              |
|                      | Pouding aux Bananes               |
|                      | Gauffres à la Crème               |
| Liqueurs             | Gelée aux pistaches               |
|                      | Pieces Montées                    |
|                      | Glacés Napolitaine                |
|                      | Biscuit Diplomate                 |
|                      | Fruits                            |
|                      | Petits fours                      |
|                      | Café                              |
|                      | Cigares et Cigarettes             |

FIVE DOLLARS PER PLATE WITHOUT WINE.

The *Brooklyn Eagle*, commenting on Dr. Parker, the now famed English preacher, says: "Dinner was his great meal, and it generally put him in a condition of gentle torpidity for two hours after his encounter with it. But his other meals were by no means to be sneezed at. Here is one of his suppers, eaten at 11 o'clock at night in his rooms in the St. George. It is an average light meal for him.

Green turtle soup for two.....	\$1.00
Fried smelts for two.....	1.00
Porterh use steak for two.....	1.00
One whole broiled chicken.....	1.10
Baked potatoes for two.....	20
Ice Cream for two.....	40
Total.....	\$4.70

SIX DOLLARS WITH WINE AT THE CAFE ROYAL, LONDON.

For the man who wishes to entertain a party at dinner, and who can afford to disregard expense, the Royal offers exceptional advantages. We give the *menu* of a dinner for which the management were responsible. They were told to draw up a *menu*

for a first-class dinner and to fix their own charge per head. The charge was £1 5s., and the *menu* as follows:

Chablis Clos, 1881.	Huitres. Impératrice.
Amontillado.	Saumon, Sauce Mousseline.
Marcobrunner.	Pommes Châteaubriand.
	Salade de Concombres.
Möet et Chandon	Blanchailles au Naturel et à la Diable.
1880,	Coquilles de Crustaces à la Café Royal.
Cuvée No. 300.	Poulets de Printemps sautés à la Chasseur.
	Quartier d'Agneau, Sauce Menthe.
Ch. Brown	Petits Pois.
Cantenac, 1875.	Pommes Rissolées.
Fine	Cailles bardées à la Casserole.
Champagne.	Salade.
Porto.	Mousse à la Napolitaine glacée.
	Fromages. Dessert.

TWO DOLLARS WITHOUT WINE.

For dinners in private rooms the prices vary. Here is the *menu* of a dinner at 7s. 6d. a head, given by the editor of a society paper to his staff of lady contributors:

- Consommé de Volaille à la Rosalie.
- Garbure lié.
- Filets de Soles à la Morney.
- Blanchailles au Naturel et à la Diable.
- Petits Ris en Caisse aux Pointes d'Asperges.
- Pigeons de Bordeaux sautés à la Nicols.
- Quartier d'Agneau, Sauce Menthe.
- Pommes rissolées.
- Petits Pois.
- Poulets de Printemps.
- Jambon d'York.
- Salade.
- Beignets de Pommes.
- Soufflés au Chocolat glacés.
- Fromages. Dessert.

A TEN-DOLLAR MEAL FOR FIVE DOLLARS.

If you are a frugal man you will never go to the Brunswick or Delmonico's alone. Take your wife, your daughter or your sweetheart along, for in these establishments each portion served will be found sufficient for two, and each is intended for two. The extra service costs nothing. If you have no lady friend or relative in town take a gentleman along, and remember, if you are on terms of close intimacy with him, that there is no impropriety in throwing out a gentle hint that the expense be borne equally by each. Your repast may cost you each a dollar, or it may cost ten dollars. Take, as an instance, this very general order:

Rockaway oysters.....	\$0.50
California brook trout.....	1.00
Shoulder of lamb.....	0.80
Mallard duck.....	1.50
Bermuda potatoes.....	0.25
Celery.....	0.40
Asparagus.....	0.60
Champagne, quart bottle.....	5.00
Malaga grapes.....	0.40
Turkish coffee.....	0.20

This sums up.....\$10.65.

Give the waiter eleven dollars and accept no change, otherwise he will be offended and will be sure to receive you with a scowl next time you call. Your meal will thus cost you each five dollars and a half. There is no extra charge for occupying a private room, but you cannot have one unless your party is sufficiently large to fill it. The smallest of these rooms is intended to accommodate four persons. A costly display of ornamentation is rarely made or desired for small parties. Regularly organized societies or clubs and associations of college graduates have the monopoly of these things, and the expense can be made light or heavy as the guests desire. A small fortune can be expended in a night on flowers, *menus* and souvenirs.

#### DINNERS AT THIRTY DOLLARS.

The *chef* at the Brunswick says that no dinner has recently been served at the establishment at which the cost per cover exceeded thirty dollars. In one instance the party consisted of forty ladies and gentlemen, who believe that the acme of human happiness is to sit perched aloft on a tally-ho as it rumbles over the highways. A bright and chatty waiter, employed in the place, said: "Dinners at thirty dollars, or even at twenty dollars, are as few and far between as those at seventy-five dollars. You will be about correct if you say a complete dinner with wine can be served to small parties for from twelve to fifteen dollars each, and for large ones at from eight to ten dollars each."

#### TEMPERANCE CATERING.

"Do you cater to the so-called temperance people?" asked the writer.

"Yes, and while there is no wine served from bottles, we manage to introduce enough of it to make the company lively. There is mighty little inspiration to be obtained out of a glass of water, and that class of people knows this as well as we do. They don't, as a rule, order us to fortify the viands with wine, but I notice that dishes which contain spirits are usually selected from the bills of fare submitted for their consideration. Roman punch is always acceptable to them and is jokingly called 'the life-saving station' of a temperance dinner. Fritters of fruits and vegetables having maraschino sauce is another temperance delight not often objected to.

"Terrapin may be good eating without a little sherry," continued the caterer, "but I have never served it without adding sherry to it. Every one knows that it is the wine which improves its flavor. Terrapin is a very popular dish among so-called temperance diners. There are a variety of sauces which are served with meats that contain more or less wine. The one most favored at these temperance dinners is sauce Bordelaise. The electric pudding, so called because it is liberally charged with brandy, was invented by a temperance dinner-giver. Here are three of their bills of fare having tipsy parson pudding on them. In desserts we can furnish an endless variety of dainties well calculated to loosen the tongues of temperance after-dinner speakers. When you want to give that kind of a banquet come and see me."

#### TIPSY FRUIT AT A TEMPERANCE BANQUET.

"The most notable anecdote of Hayes' administration seems to have been that relating to the device resorted to to turn the flank of Mrs. Hayes' determination to allow no intoxicating beverages at her table. Mr. Evarts, Secretary of State, refused to permit the Diplomatic Corps to be invited to their customary annual dinner unless wine could be on the table. This Mrs. Hayes refused to allow; but the stew-

ard managed to gratify those fond of something stronger than lemonade. Among the delicacies on the table were an extraordinary number of oranges, and waiters were kept busy replenishing the salvers on which the tropical fruit lay. Glances telegraphed to one another that the missing link was found, and that, concealed within the oranges was delicious frozen punch, a large ingredient of which was strong old Santa Croix rum. This phase of the dinner was named by those who enjoyed it 'the life-saving station.'"

#### PROHIBITIONISTS AND FASHIONABLE COOKERY.

There is no little stir among the prohibitionists who attended the great banquet at Martinelli's the other night, for it has been discovered that brandy, wine, white and red, and other liquors were served to them in disguise. The banquet was served in honor of Brother Demarest, their great leader.

While no liquor was served as a beverage, and not even Roman punch appeared in that part of the feast known as the life saving station, yet the discreet cooks had in other respects not been sparing of various forms of alcohol. For instance, in the mushroom sauce there was some fine old brandy, whose function in the sauce was to prevent it from fermenting. In the bisque of lobsters was some royal old sherry, placed there to prevent the lobster from settling to the bottom of the soup plates.

One of the firm who run the establishment under Martinelli's name said:

"There is nothing so discouraging to a caterer as serving a series of prohibition spreads, and we would not have taken that night's order were it not for the fact that some of the gentlemen dine here occasionally and drink claret with their meals. A caterer who serves many so-called prohibition dinners somehow gets the reputation of not caring to serve fine dinners. Yet we are obliged to use liquors secretly, or our reputation is ruined. Every cook

knows that a bisque of lobster must have wine in it to tone it up, and no cook ever lived who made a mushroom sauce to serve with meats without brandy or a heavy wine to keep it of the proper consistency.

"Now, had they paid \$4 per plate for their dinner, we would have given them a temperance banquet that would have made their hair curl. First, we would give them mock turtle soup, which for a party of sixty would take four bottles of sherry to tone it up. Then we would give a baked striped bass, with sauce Bordelaise, which everybody knows contains a large amount of claret. Chicken Bearnaise would follow, and by this time the guests would begin to be communicative and begin to enjoy their dinner. We always serve Roman punch at these first-class prohibition feasts, but disguise it under another name and conceal the flavor of the rum or kirsch by strong vanilla and other flavors, but orange is the best flavor to use for this purpose. The name under which this punch is generally served is punch cardinal.

"Topsy parson pudding is, strange as it may seem to you, the favorite dessert at these dinners. We soak the cake in sherry, then cover it with a rich custard sauce, and it takes like hot cakes on a frosty morning. The most acceptable cream is St. Honore. This contains a fine cordial-flavored cream surrounded with macaroons, and these are surrounded with brandy cherries. As for cheese they prefer it mixed to a paste and moistened with brandy. This, when spread upon toasted crackers, is delightful. No one, prohibitionist or *gourmet*, can have a dinner which is worth eating in which liquor does not perform its function, open or concealed, and we never gave a temperance dinner in which brandy and wine were not used in cooking."

#### TOO RICH FOR HIS BLOOD.

"The Major-General in charge of the militia here (San Francisco), after reading the interview which a reporter had with the captain of the salvation army, con-

cluded that he ought to show him some military courtesies, and so invited him to dinner. 'Hallelujah! How d'ye do?' said the visitor on entering a fashionable restaurant, in response to the invitation; and as he looked round and saw nothing but water on the table, he smiled approvingly. 'And you drink water, too, general?' said the salvationist. 'Most frequently,' was the reply. 'Here's to your health, brother soldier!' And the mundane and spiritual officers pledged each other. The first course was terrapin soup, with about a bottle of good old Madeira in it. It was a new dish to the salvationist, and he brightened up considerably after the third plateful, and asked all about the habits of terrapin. 'Hallelujah! but it's comforting and warming.' 'Only a very plain repast,' replied the M.-G., as the waiter brought on a roast hare with currant jelly and Burgundy sauce. 'Delicious eating, a hare,' said the captain, 'and magnificent sauce this. We poor soldiers of the church seldom fare like this. Gimme some more sauce. And what exquisite coffee!' he continued, as he swallowed a cup of black coffee with a glass of cognac in it, and passed it to the waiter to refill it. 'So proud to meet a man like you, general, in this city! Such noble example! Going to write to headquarters to-night. Splendid omelette that, too, looks as if it had been on fire.' 'Try a preserved peach,' said the general, helping his guest liberally to some brandied peaches; 'they are very soothing—and just one more cup of coffee before you go.' 'Hallelujah! general, don't care if I do. Shay, genrul, dontyherfeel shleepy?' And the good man bowed his head on the table, and was dreaming in three minutes that he was leading a crusade in Chicago and had converted 14,000

gamblers. When he woke up he did not feel well, and his host was facing him, blowing a fragrant Havana. 'Accept my carriage home, captain,' he said as he led him into a four-bit coupé and told the driver where to take him. The captain did not preach that night, and he has been wondering ever since whether there was not something queer about that coffee."

SARCASTIC, BUT SUGGESTIVE.

"The caterer for the ball or dinner at the residence of the hosts often supplies all the linen and table ware, as well as the decorations and feast. The caterer generally has a large supply of the articles needed, from a dozen salt cellars to a large epergne, with accommodation for a miniature lake for live gold fish to disport in, and reaps a handsome profit from their hire on these occasions. He generally purchases these articles at auction, and keeps them in fine condition. He is chary about purchasing any silver or china with monograms, for the obvious reason that the initial would often prove embarrassing to many hosts. He does not object to the inscription 'Mother,' or 'From Father,' because that would be applicable in almost every case, excepting that of a bachelor. His bonanza is silver-ware containing a crest. He always finds that such pleases his hosts. The caterer takes entire charge of the culinary arrangements and the preparation of the table, supplying the servants and superintending the service as well. He transports his wares in specially constructed boxes, takes his gripsack, prepared for any change in the weather, and the business is so well systematized that there are ordinarily no hitches or mistakes. Often the family table ware, linen and china are not used."

# STEWARDING AND CATERING ON A GRAND SCALE.

## STEWARDING AT HARVARD UNIVERSITY.

The boarding of the Harvard students is managed on the co-operative plan by a "Harvard Dining Association," which is like the "house committee" of many clubs, but on a larger basis, the different classes and schools being represented on the "Board of Directors," which is composed of fifteen students and is the executive body which engages the steward, second steward and headwaiter.

This "house committee" of fifteen, standing in the position of the hotel-keeper, has the task to perform of setting a good table at the lowest possible rate, the students under this arrangement being furnished with board at its actual cost, and the price consequently fluctuates according to the running expenses from \$3.90 to \$4.20 a week. The *menu* of the three meals is:

### BREAKFAST.

Oatmeal.      Cracked Wheat.  
 Fried Cod.  
 Mutton Chops.      Eggs.  
 Lyonnaise Potatoes.  
 Griddle Cakes. Hot Rolls. Toast. Coffee. Tea.

### LUNCH.

Chicken Soup.  
 Cold Corned Beef.      Cold Ham.  
 Oatmeal.      Cracked Wheat.  
 Pumpkin Pie. Mince Pie. Cheese. Cocoa.

### DINNER.

[*Sample, changed daily.*]

SOUP.  
 Macaroni.  
 FISH.  
 Boiled Cod.  
 ROAST.  
 Beef. Chicken. Lamb.  
 ENTREES.  
 Beef à la mode.  
 VEGETABLES.  
 Boiled potatoes. Mashed Potatoes.  
 Lima Beans. Turnips. Hominy.  
 DESSERT.  
 Steamed Apple Pudding.  
 Apples. Oranges.

In addition to the regular *table d'hôte* there is an order list à *la carte*, comprising all the luxuries of a first-class restaurant. From this anything will be served at any meal for a reasonable extra charge; all the bills are settled thrice a year at the conclusion of each term. The order list is a most wise provision, for, while it enables one to entertain a friend in an eminently satisfactory manner, it causes the luxuriously inclined to lower the price of living to the more economical—in other words, if the restaurant makes a profit it lessens the price of board to all.

Breakfast is served from 7.30 to 8.30, with a table for orders only until 10 a. m.; lunch occupies the hour between 12.30 and 1.30, and the dinner hour is from 4.30 to 5.30 in winter and half an hour later in summer. It will be observed that the lateness of the dinner hour gives the college athletes a fine hygienic opportunity to exercise on something other than a full stomach.

The salaried officers are the steward, assistant steward and headwaiter. Under them are eight cooks, sixty waiters and twenty-five other servants. The number of members at present, six hundred and sixty. As might be imagined that number of healthy men are heartier eaters than the average patrons—and matrons—of hotels. There are stowed away daily in the cavernous aggregate collegiate maw one hundred and seventy gallons of milk and five bushels of apples, besides about three hundred pies. It is humiliating to confess that all the wealth of Cambridge intellect cannot educate the American youth above pie, but the fact must remain.

The steward and auditor make their statements every two months. The appended copy of these sheets for the months of January and February will give perhaps a clearer insight than mere words into the financial workings of this eminently successful co-operative organization:



DR.	
Bills paid (less water bill).....	\$19,675.61
Water charge .....	48.87
Interest on debt.....	539.42
Interest on advances.....	113.77
Reduction of debt.....	333.34
Insurance.....	50.00
Crockery assessment.....	200.40
Allowance for absence, etc.....	544.20
Stock on hand (Jan. 1).....	2,300.59

\$24,155.90

CR.	
Stock on hand (March 1).....	\$2,533.57
Sale of grease.....	317.91
“ swill.....	68.87
“ bones.....	67.86
“ cold food, etc.....	193.96
Gas and coal for Saunders' Theatre...	53.95
Extras ordered.....	1,519.95
Crockery charged to surplus.....	57.71
Balance.....	19,337.32

\$24,155.90

Dividing this balance of \$19,337.32 by 5,010, the number of weeks, or students, gives \$3.86; adding head money, 10 cents, gives \$3.96, or say \$4.00 as the cost of board during January and February. An analysis of this charge of \$3.96 gives the following result:

	Jan. and Feb.	Per week.
Provisions.....	\$12,413.30	\$2.47½
Service.....	3,547.91	71
Coal.....	400.48	08
Water.....	48.57	01
Gas.....	365.30	07½
Breakage.....	200.40	04
Interest.....	653.19	13½
Reduction of debt.....	333.34	07
Repairs.....	211.21	04
Allowance for absence.....	544.20	10½
Miscellaneous.....	219.42	04
	\$19,337.32	\$3.86
Head money.....		10
		\$3.96

The head money, let me briefly explain, is given to the steward when the average weekly amount is small—as it enlarges the head money is reduced—virtually giving him a bonus for economy.

STEWARDING AT VASSAR COLLEGE.

“We have no patience with those journals which indulge in ungallant remarks and ribald laughter over the annual statement of what the sweet Vassar girls have been eating during the school year. The figures presented by the board of trustees grow more and more serious year by year, and the statistics for 1886-87, now at hand, are simply appalling. To begin with, the dear, delicate creatures consumed 230 barrels of flour. Their small white teeth

opened and closed upon 100,000 buckwheat cakes, 10,000 bananas, 30,000 oranges and lemons, and 32,000 clams. They further diminished the resources of the country by swallowing 84,000 pounds of fresh meats, 8,000 pounds of smoked meats, nearly 5,000 pounds of turkeys, over 4,000 pounds of chickens, nearly as many of fish, 141 gallons of oysters, 14,000 pounds of butter, 95,000 quarts of milk, 25,000 pounds of sugar (whence their unusual sweetness), and 1,000 bushels of potatoes. Add to this tea and coffee, condiments, fruits, vegetables, sweet-meats, and surreptitious luncheons, and the total becomes positively colossal. If this rate of consumptions increases, or even continues, it will be expedient to have the daily food purchases of Vassar included in the market reports of the country for the sake of their effect upon prices.”

STEWARDING AT WINDSOR CASTLE.

“The holidays bring a wealth of work for the cooks at Windsor. The kitchen, on the north side of the castle, is fitted elaborately enough to delight the heart even of a Careme. The apartment is nearly fifty feet in height, and has an enormous fire at either end, with a system of spits after the fashion of university kitchens. As an ordinary staff there are the chef de cuisine, two master cooks, two yeomen of the month, two roasting cooks, two larderers, five scourers, one steam man and three kitchen maids, besides apprentices and serving men. The number of dinners that can be cooked in this kitchen is simply marvelous. Every detail of the arrangements is worked out with the greatest of care, the dishes being handed straight to the footmen from the cooks, and by them conveyed to the various rooms.”

STEWARDING AT A PENITENTIARY.

“The provisions required for the dinner given, the convicts at Joliet, Ill., on Thanksgiving were 1,700 pounds of dressed turkey, 60 gallons of turkey dress-

ing, 80 gallons of gravy, 30 bushels of potatoes, 6 barrels of flour, 5 bushels of onions, 200 gallons of coffee, 16 gallons of milk, 85 pounds of sugar, 40 pounds of English currants, 120 pounds of butter, 30 gallons of syrup, 15 barrels of apples, 3,200 cigars. Each of the married gaurds was given a turkey."

#### STEAMSHIP STEWARDING.

"The Atlantic steamship City of New York is commanded by Capt. Frederick Watkins, and his right hand man, the chief officer, is S. F. Barff. To help these two to navigate the ship six deck officers are provided, and three of them are constantly on deck when at sea. In addition to these, in what may be called the department of seamen, there is a boatswain and his mate and 36 sailors, of whom 12 men are called quartermasters, who are detailed to steer the ship and stand on lookout.

"Mr. McLeod, the chief steward, is assisted by Mr. Findlow, formerly steward of Jay Gould's yacht Atalanta, and by 146 other people, of whom seven are women and eight are boys in their teens, called bell boys. Mrs. Nichol is the chief stewardess, and four women help her in the first cabin. The second cabin and the steerage have one stewardess each. Of the other people in this department 36 are table waiters, 16 are bedroom stewards and attend to keeping staterooms in order, 10 are occupied in the pantry, 16 are cooks, 6 are porters, 5 are messroom stewards and wait on the officers, 14 are in the second cabin, 16 are in the steerage, 4 are bakers, three are butchers, and 5 are storekeepers, and this term includes the bartenders and the men in immediate charge of the rooms where provisions, etc., are kept.

"There is also a ship's carpenter, who is generally as handy aloft as with the saw and adze. In charge of the machinery are a chief engineer, Mr. McDaugall, and 27 assistant engineers, besides 2 electricians and their 3 assistants, who look after the electric lights; 3 donkey men, 31 leading firemen, 54 firemen, 63 trimmers, and

one blacksmith. The donkey men are foremen in charge of the boilers; the leading firemen are also called greasers, and it is their duty to keep the machinery oiled and cleaned. The 54 firemen shovel coal into the furnaces and se that it is spread just right to burn as hot as possible, and when the furnace needs cleaning they do the work. The trimmers shovel the coal from the bunkers into the stoke hole.

"While this completes the list of the three great departments into which a ship's company is divided, there is yet a purser, who is a keeper of accounts, besides having a lot of other important duties to attend to, and the ship's surgeon, who has one assistant. The number of stewards carried varies with the passenger traffic. The total number of crew of the City of New York when she sailed was, according to the purser, 394.

"Few persons are aware of the extensive nature of the victualling on board the great ocean steamers. Each vessel is provisioned as follows for the round voyage for passengers and crew: 3,500 lbs. of butter, 3,000 hams, 1,600 lbs. of biscuits, exclusive of those supplied for the crew; 8,000 lbs. of grapes, almonds, figs, and other dessert fruits; 1,500 lbs. of jams and jellies; tinned meats, 6,000 lbs.; dried beans, 3,000 lbs.; rice, 3,000 lbs.; onions, 5,000 lbs.; potatoes, 40 tons; flour, 300 barrels; and eggs, 1,200 dozen. Fresh vegetables, dead meat and live bullocks, sheep, pigs, geese, turkeys, ducks, fowls, fish, and casual game are generally supplied at each port, so that it is difficult to estimate them. Probably two dozen bullocks and 60 sheep would be a fair average for the whole voyage, and the rest may be inferred in proportion. During the summer months, when travelling is heavy, 25 fowls are often used in soup for a single dinner.

"The bar on an ocean vessel is one of the most profitable features of the ship, and it has been said that \$5,000 has frequently been cleared on one voyage by a first-class steamer in the busy season. The possibilities in this direction may be judged

from the fact that the Etruria puts on board at Liverpool for the round voyage 1,100 bottles of champagne, 850 bottles of claret, 6,000 bottles of ale, 2,500 bottles of porter, 4,500 bottles of mineral water and 650 bottles of various spirits, while the annual consumption of the Cunard Line is as follows: 8,030 quarts and 17,613 pints of champagne, 13,941 quarts and 7,310 pints of claret, with 9,200 bottles of other wines, 489,344 bottles of ale and porter, 174,921 bottles of mineral waters, 34,000 bottles of spirits, 34,360 pounds of tobacco, 63,340 cigars and 56,875 cigarettes.

#### THE PURCHASING STEWARD OF A LARGE HOTEL.

The following was one day's marketing, bought before and about sunrise, for the Fifth Avenue Hotel, New York; a fair example of the daily purchases, making allowance for fluctuations of business at different seasons:

8 loins beef.  
 4 ribs beef.  
 2 hips beef.  
 1 rump corned beef.  
 7 calves' heads.  
 88 pounds veal.  
 2 old turkeys.  
 20 young turkeys.  
 57 pounds chickens.  
 55 pounds lobsters.  
 23 pounds bluefish.  
 55 pounds Spanish mackerel.  
 10 barrels potatoes.  
 2 barrels sweet potatoes.  
 3 barrels cabbage.  
 1½ barrels spinach.  
 1 barrel cooking apples.  
 93 pounds grapes.  
 4 legs mutton.  
 6 mutton racks.  
 12 racks lamb.  
 1 lamb.  
 40 kidneys.  
 7 doz. sweetbreads.  
 2 pairs mongrel ducks  
 2 doz. woodcocks.  
 2 doz. partridges.

20 pounds sea bass.  
 29 pounds soles.  
 28 pounds salmon.  
 1½ bags Lima beans.  
 1 bushel beets.  
 4 boxes tomatoes.  
 325 ears corn.  
 4½ doz. bunches celery.  
 1 doz. egg plants.  
 1 dozen cucumbers.  
 2 boxes lemons.  
 Parsley, mint and soup vegetables.

All supplies brought to basement and carefully weighed before putting away. Groceries bought monthly, except coffee and tea which are procured whenever an opportunity for a good bargain is offered.

#### THE AMERICAN GAME LIST.

For nearly thirty years an annual game dinner has been given by Mr. John B. Drake, proprietor of the Grand Pacific Hotel, Chicago. The number of guests is usually 500, and they are attended at table by 100 waiters. For weeks and even months before the event measures are put in operation to get together every possible species of game, the result being as is shown in the subjoined bill of fare, which is a very good game list for stewards and restaurateurs to consult for available kinds. This occurred a few years back, when elk and buffalo were still obtainable; the list is slightly more voluminous than more recent ones, and the more useful for reference to so many kinds.

"To name the people present would be only to give a list of the most prominent and the wealthiest of Chicago's citizens and of the distinguished guests now stopping at this hotel:"

#### MENU.

Blue Point Oysters in Shell

#### SOUP.

Consommé de Vollaile au Praire      Game

#### FISH.

Broiled Whitefish      Baked Red Snapper

#### BOILED.

Ham of Black Bear      Wild Turkey  
 Leg of Mountain Sheep      Buffalo Tongue.  
 Venison Tongue

## ROAST.

Saddle of Mountain sheep Leg of Black Tail Deer  
 Loin of Buffalo Leg of Elk  
 Saddle of Antelope Coon Opossum  
 Loin of Venison Jack Rabbit Mountain Bison  
 Wild Turkey Pin Tail Grouse Ruffed Grouse  
 Virginia Partridge Golden Plover  
 American Woodcock Killdeer Plover  
 Sand Hill Crane Wilson Snipe Canada Goose  
 Mallard Duck Pin Tail Duck Gadwall Duck  
 American Widgeon Blue-winged Teal  
 Green-winged Teal Shoveler Duck Wood Duck  
 Scaup Duck Red Head Duck Ruddy Duck  
 Woodchuck Canvas-back Duck  
 Buffle-Head Duck Cormorant Duck Dusky Duck  
 Brant Quail Red Bill Merganser Duck  
 Carolina Dove Ring-necked Duck  
 Hooded Merganser Duck Spruce Grouse  
 American Coot Long Tail Duck Partridge  
 Red-necked Grebe Prairie Chicken Pheasant  
 Butter-Ball Duck

## HUNTER'S HOME ON THE RANCH.

## BROILED.

Red-winged Starling Reed Bird Gray Snipe  
 Blue-winged Teal Fox Squirrel  
 Gray Squirrel Black Squirrel Gray Rabbit  
 Jack Snipe Golden Plover Partridge Quail  
 Least Sandpiper Butter-Ball Duck  
 Prairie Chicken Pheasant Dunlin Sandpiper

Baked Sweet Potatoes Mash d Potatoes  
 Sweet Corn Green Peas Celery Plain Potatoes  
 Stewed Tomatoes

## ORNAMENTAL DISHES.

Pyramid of Game, en Bellevue  
 Red-winged Starling, au Natural  
 Aspic of Birds, à la Royale  
 Pattie of Liver, sur Socle  
 Boned Quail in Plumage  
 Galantine of Turkey, with Jelly  
 Pin-Tail Grouse, in Feathers  
 Boned Snipe, with Truffles  
 Shrimp Salad

## THE TWO PETS.

## ENTREES.

Buffalo Steak, Mushroom Sauce  
 Stuffed Venison, Hunter Style  
 Salmi of Grouse, Port Wine Sauce  
 Squirrel, Braise, Sauce Diable  
 Deer's Tongues, Boule, Caper Sauce  
 Frogs, fried, Camp Style  
 Pheasant, larded, aux Champignons  
 English Hare, with Dumplings  
 Charlotte Russe Chocolate Eclairs  
 Chocolate à la Crème  
 Chantilly Cream, à la Printanière  
 Bonbons, assorted Fancy Cake Nougat Pyramids

## SONG.

"The Wanderer's Return," . . . . . *Abt.*  
 By the Blaney Quartette.

Apples Oranges Pears California Grapes  
 Concord Grapes Catawba Grapes Nuts Figs  
 Raisins Vanilla Ice Cream Pineapple Sorbet  
 Sage Cheese English Cheese Coffee

## SONG.

"The Gay Pilgrim," . . . . . *Mangold.*

## LUNCH FOR 5,600 PEOPLE.

"Mr. William H. Somers, proprietor of the West Shore restaurant at Syracuse,

was called on Sunday last to cater to the appetites of 5,600 hungry travelers, *en route* to the Odd Fellows' meeting at Boston. They arrived in detachments of two to five hundred during the afternoon at intervals of half an hour, and were all promptly cared for. A local paper says that 'Mr. Somers, in anticipation of the event, had ordered the waiters and cooks all along the line of the West Shore to report for duty here. He had 225 people under his command, and so perfect were the arrangements that all moved like clock work. The service of a hot dinner was out of the question, but the tables were neatly spread with dainty white cloths and set with unimpeachable knives, forks and crockery, delicately cut, but substantial slices of cold meats, together with the usual accompaniment of bread and butter, besides fruit, tea and coffee. The stock of eatables consisted of 2,000 pounds of beef, 1,500 pounds of chicken, 2,000 pounds of ham, 1,000 quarts of milk, 2,000 loaves of bread, 500 pounds of fresh pork, four barrels of lamb tongue, 3,000 sandwiches, and 2,000 pounds of grapes.' About 1,000 bottles of beer and spirits and \$125 worth of cigars were sold."

## THE AMERICAN CLAM BAKE.

"Mr. Sol. Sayles, the well-known butcher of Sixth avenue, gave his annual clam bake to his sixty odd employés at his country seat, Eleanor Villa, beautifully situated at Long View, on the Raritan River, N. J., on Sunday afternoon. A special train of the New Jersey Central Railroad conveyed the guests, who numbered, including the employés, 110 persons, to Plainfield, the nearest station, where they were met by carriages in waiting and conveyed over a delightful road to the grove in which the feast was prepared under the guiding hands of J. C. Shields, who, as the steward of the Glen Island restaurants for several seasons, has justly earned a reputation as a constructor of toothsome Rhode Island clambakes. At 4 o'clock the feast was ready, and ample justice was done to it under the appetizing

zest imparted by the long drive in the bracing air. The bake was composed of one thousand hard and soft clams, 50 lobsters, 150 ears of corn, 50 bluefish, 50 white bass, 2 bushels of white potatoes, 2 buseels of sweet potatoes, 75 spring chickens, 150 hard crabs, 100 pounds of tripe and 75 watermelons. Flanking this steaming pyramid were 200 bottles of iced champagne. When the feast was concluded Patch photographed the entire group on the lawn."

#### HOW IT IS DONE.

"A hole, some four feet deep, is dug in the ground, and smooth flat stones are laid on the bottom; on these a fire of wood is kindled, which is kept up half a day or more, until the stones are of a red heat. Then several bushels of clams in the shell are poured over the stones, and on these are laid a layer of seaweed. Indian corn in the ear is placed, in quantity proportionate to the number of bushels of clams, upon this; then follows another layer of seaweed, and more clams, then a few dozen chickens prepared for cooking; then another layer of seaweed and more clams; potatoes in their jackets come next, although some put the potatoes in an anterior stratum, and more clams. Any game in season may be added, and the top layer is always seaweed, preceded by more clams. In Rhode Island turkeys are deemed the essential layer late in the autumn. The heat evolved from the stones and retained from the fire in the sides of the pit, and the steam rising from the seaweed, serve to slowly and thoroughly cook each and every layer in about two hours, and then they are deftly taken out and served on long tables, with much care and neatness. The choicest wines accompany the feast, although cider is the common drink of the people. The service is scarcely in regular courses, as the tooth-someness of the repast lies in the fact that the juices are so assimilated and interpenetrated by the mode of cooking that the guests desire not to stand upon the order

of their eating, but take in thankfulness that which is set before them, with one proviso—that the supply of clams be endless."

#### THE AMERICAN BARBECUE.

It is commonly called roasting oxen or other animals whole; the word itself is French *barb-a-que*—from head to tail—but in practice so many disappointments occur through the meat coming from the bars burnt to a coal on the outside and too raw to be eaten inside, that those who have had experience take care to roast only quarters or sides. The way it is done is the same in the beginning as the clam bake; a trench is dug in the ground and a wood fire made in it. When it has burned about six hours and the pit bottom is covered with a bed of glowing coals and red hot rocks, instead of the covering up in sea weed as at the clam bake, some bars of iron are laid across the pit, making a monster grid-iron. Perhaps the iron can be obtained from the village blacksmith, or some old rails from the railroad, or two or three rails and small iron for cross-bars. Whole sheep and lambs can be roasted very well over such a bed of coals, also small pigs, chickens, 'possums, turkeys and such small animals, but oxen are better cut in quarters, as in that case it does not take more than an hour or two to cook them sufficiently. Occasions requiring a resort to the barbecue are constantly arising, either political or otherwise, for anniversaries, camp meetings, celebrations of various descriptions, and it only needs the trench to be dug the longer to give cooking facilities in the meat line to an indefinite extent; the bread is easily baked at a distance and hauled to the spot. But the great trouble experienced generally is to get the provisions divided among the people after the cooking; if this is not well managed two or three persons will drag a quarter of beef from the fire into the dust of the ground, hack off their few slices and leave the rest in such a condition that it is almost if not quite lost. Some well intended barbecues for army

reunions and monument raisings and the like have become hideous failures through such want of management. There must be a fence around the barbecue fire and another around the benches to eat from, and proper arrangements made for cutting up and passing around the meat after it is cooked, if suffering to the invited multitude and life-long reproach to the providers are to be averted.

#### THE IMPROVED BARBECUE.

Barbecues have taken place in late years where oxen were actually roasted whole and made superior as roasted meat to the product of city kitchens by fastening the entire carcasses on iron spits on frames with band-wheel fixtures, and revolving them horizontally by means of a small portable steam engine over the heated pits of coals until done. In one case recorded when the ox was considered sufficiently done it was moved by means of a crane to a table where six skillful carvers were ready with extra large knives and forks, and cut it up and distributed it in a proper manner.

#### THE PRIMITIVE BARBECUE.

"Messrs. Cody and Salsbury, of the American Wild West Show, invited a number of their friends recently to an Indian 'rib-roast' breakfast, at which the principal item that figured upon the 'bill of rations' consisted of ribs of beef roasted, served, and partaken of in the primitive Indian style as follows: A hole is dug in the ground, a wood-fire lighted therein, and over this is suspended from a tripod the huge sides of beef; these are kept moving by a squaw or scout for three-quarters of an hour, at the end of which time the joint is sufficiently done, and resembles a bunch of 'devil'd bones.' Each 'brave' squatted upon the ground on a carpet of loose straw was provided with a sharp stake stuck into the earth in front of him, and a goodly portion of the roasted ribs, which, when not engaged in biting the meat off the bone held in h's hands, he stuck on to the sharp stake, which thus took the place of a plate.

He then licked his fingers clean, and wiped them dry on his hair. The majority of the guests adopted the Indian manner of eating the meat—bar the licking-finger performance, as a substitute for which table-napkins, etc., were provided. The meat was said to be so toothsome, that an eminent English legislator present expressed his opinion thereon to the effect that 'civilization was a well-intentioned mistake.' The rest of the *menu* was American, viz., grub-steak, salmon, roast-beef, roast-mutton, ham, tongue, stewed chicken, lobster salad, American hominy and milk, corn, potatoes, cocoanut-pie, apple-pie, Wild West pudding, American pop-corn and peanuts, which, with other etceteras, ended this unusual form of entertainment."

#### AN ELECTRIC LIGHTED BARBECUE.

"Over four thousand persons, from the neighborhoods and towns of both High and Low Harrogate, assembled and took part in the proceedings, which were, from beginning to end, conducted in a successful manner. To commence with, a splendid red and white four-year-old ox was purchased by Mr. Samson Fox, and fed by Mr. Stephen Bradley in a field adjoining his residence. Here it became an object of much curiosity and comment amongst the town-folks, who watched it graze with eager interest in anticipation of roast beef *ad libitum* in the near future. Upon the eventful day, Mr. M. Church, *chef* at the Queen Hotel, superintended the cookery arrangements, and succeeded to perfection; for, as Mr. Fox (the spirited gentleman who liberally came forward to defray all expenses) afterwards said, 'the ox had been as well roasted as though it had been done in separate pieces.'

The animal was slaughtered, dressed, and duly fixed upon the spit of solid iron, revolved by steam power at the rate of about three times a minute. Two huge fires were employed—one stationary, and the other movable. A barricade was erected around the ox, and, although it was not ultimately called into use, a suitable covering was

provided to guard against inauspicious weather. A powerful dynamo illuminated the whole scene with the electric light during the hours of dusk and night, and sounds of revelry (music and dancing) contributed to the enjoyment of all, whilst the ox was kept constantly revolving throughout the night.

At noon on Tuesday, the 21st June, the cutting up and serving out of the animal was inaugurated by the committee, who mounted a wagon placed alongside of the roasted ox on its spit. Five carvers were told off, and each one received a huge carving knife and fork, specially made for the occasion. After a brief but appropriate speech from Mr. Fox, three cheers were given and each carver made a primary incision; and then followed up quickly the division, presumably along the principal lines of the six-and-thirty usual 'joints,' and the slicing off of the tit-bits.

About 4,000 pieces of meat, buns, and tickets for beer were rapidly distributed amongst the guests ranged around the 'festive board,' and as daylight waned the dynamo once more shone forth upon a scene of innocent revelry, 'where all went merry as a marriage bell.'"

#### HOW AN OX WAS BOILED WHOLE.

"A correspondent of the *Times* mentions an experiment, rare, if not unprecedented, which was tried on Jubilee Day at Liss, a village on the London and South-Western Railway in Hampshire. It consisted in boiling a bullock whole, in addition to one roasted the evening before. A hole, dug in the ground, was built over with bricks; into the latter was built a tank, and into the tank was lowered the carcass, placed within a case formed by iron bars, to which chains were attached. Pulleys from a scaffold immediately above raised and lowered the ox, of which the head and carcass were sewn up separately in strong canvas. Carrots were boiled with it, and potatoes enclosed in bags, making gallons of rich soup. At 5:30 p. m. the carcass, which had been boiled about seven hours, was raised from

the tank; two bands playing 'God save the Queen' and 'Rule Britannia' on the scaffolding above. The meat was pronounced excellent, and was certainly well cooked."

#### THE NUMBER, WEIGHTS AND PRICE—A POUND TO A PERSON.

"The energetic proprietor of the White Horse Hotel, Romsey, and the Tregonwell Arms, at Bournemouth, recently carried out a large job in the catering line. On the occasion of the great Liberal Fête at Templecombe, on the 1st inst., he was entrusted with the purveying for the Bournemouth Division, consisting of some 3,000 persons, each one of whom was to be supplied with 8 oz. meat, 8 oz. bread, and 2 oz. cheese, at 1s. 6d. (36c.) per head. Two tents were provided, and tables arranged to seat 350 and 550 at a time respectively; the former was filled four times, and the latter thrice in succession, and the whole of this large assemblage was efficiently attended to by a staff of seventy waiters, carvers, etc.; 1,525 lbs. of cooked beef, mutton, chicken, and ham, 1,525 lbs. of bread, and 6,100 oz. of cheese were consumed, the whole of the viands being cut up into portions on the day of the feast."

#### THE GOVERNMENTAL BANQUET TO 3,000-FRENCH MAYORS.

"The great gastronomic fête held in a wing of the Exhibition building on the Champ de Mars, Paris, last month, July 1888 has been a good deal discussed in the newspapers, but no authentic account of the organization and service of the monster feast has hitherto appeared in print. We now have pleasure in supplying such particulars from the pen of our valued collaborator M. Suzanne, who, himself an eye-witness of the banquet, has obtained supplementary details from the great catering firm of Potel and Chabot, who were the appointed purveyors:

"A *table d'honneur* was reserved at one end of the room for President Carnot and his numerous *entourage*, composed of 340 persons, and including members of the

Government and the most notable representatives of art, science, industry, and commerce. The two services were also represented by officers of the highest grade in uniform, and at the other end of the room, facing the President, and mounted on a raised platform, played the unrivalled band of the Garde Républicaine, whose melodious strains served to pleasantly mask the unavoidable rattle of the plates and the simultaneous plying of 3,000 knives and forks. Besides the *table d'honneur*, there were fifty-six minor tables symmetrically arranged in rows of seven. These tables were isolated from each other by a wide space so as to avoid incumbrance, and to allow free circulations to the servants. Corresponding to each row of seven tables was a broad passage leading to a kitchen, where ten cooks were at work. Consequently there were in all eight kitchens and eighty cooks employed.

"Each kitchen was fitted up with a range, a complete set of steam cooking apparatus, and eight or ten charcoal stoves; but I remarked that there were no gas appliances of any kind. Each table was laid for fifty persons, and bore a central placard, duly numbered, and indicating the names of the respective provinces, so that the representatives of each could group themselves together.

"The mayors, who had been previously supplied with a miniature plan of the dining-saloon containing detailed information, experienced no difficulty whatever in finding the places allotted to them. As the clock struck seven, the entire company were seated, awaiting the arrival of President Carnot. In front of each table stood a headwaiter, whose mission it was to superintend and survey the service of the section confided to his charge. In all, there were 350 waiters on duty.

"Upon the arrival of the President and his ministers, the band struck up the National Anthem, and simultaneously a signal given by M. Lasson, when the eight doors leading to the kitchens were thrown open as if by magic, and one hundred

"garçons" marched into the dining-room, each carrying a tureen of potage à la St. Germaine. A few minutes later, this body of waiters made their exit with the empty tureens.

"After the soup, according to French fashion, "hors d'œuvres" were handed round. The relish materials consisted of 350 bundles of radishes, 75 lbs. of Lyons sausages, 400 boxes of sardines, 125 lbs. of prawns, 50 lbs. of olives, and 40 lbs. of butter, in pats. The soup was "relieved" by 120 dishes of trout in jelly, with French sauce, the latter being a mayonnaise in which a purée of lobster coral and some whipped cream had been mixed.

"The hot dishes followed: 75 braised fillets of beef, which were larded and garnished with stewed carrots, no fewer than 300 bunches of that vegetable having been prepared for the purpose. The roasted turkey poults, to the number of 300 were also served hot. To accelerate the service, they had been previously carved in the kitchens, and were brought to table with 300 bowls of dressed salad; 80 galantines truffées, and 80 pies were afterwards introduced.

#### THE MENU.

Potage St. Germain.  
Hors d'Œuvres.  
Truite à la Gelée, Sauce Française.  
Filet de Bœuf Parisienne.  
Galantines de Poulardes truffées.  
Dindonneaux Nouveaux rôtis.  
Pâtés de Foies Gras.  
Salade.  
Petits Pois à la Fermière.  
Bombe glacée.  
Gâteaux Variés.  
Baba au Rhum.

#### DESSERT.

VINS.  
Madère Vieux.  
Bordeaux Grave.  
Beaune. Champagne.  
Café.

"Then came the entremets: 300 dishes of stewed peas, babas au rhum, bombes glacées, and numberless dishes of all kinds of pastry. The dessert was composed of all the fruits in season, such as strawberries, cherries, apricots, grapes, and pineapples. There were also an infinite number of compôtes, and endless pyramids of biscuits and bonbons. A bottle of claret



was placed before each guest; but independently of that, champagne, madeira, choice burgundy, and liqueurs were served with the second course. Three thousand seven hundred bottles of wine were consumed at this gigantic banquet. The 3,000 cups of coffee distributed after the repast were also prepared by the contractors, who had hired two immense coffee-making apparatuses, such as those used for army campaigning purposes, and known as "percolateurs." With the coffee, liqueurs and spirits were introduced, the number of bottles emptied being as follows: 125 bottles of cognac brandy, 75 bottles of kirschwasser, and 70 bottles of chartreuse.

"The description of this gastronomic function would not be complete without some mention of the table utensils used for the occasion. These consisted of 27,000 plates, 15,000 wine-glasses and tumblers, and 12,000 sets of knives and forks.

"The orderly and efficient manner in which the whole affair was conducted reflects the greatest credit on the caterers, who, needless to say, had to encounter numberless difficulties. Thanks to their skilled experience and well-considered arrangements, all obstacles were overcome, and the fame of Potel and Chabot as mammoth foodproviders not only upheld, but distinctly enhanced.—*London Caterer*.

#### A RAILWAY EATING HOUSE IN SWEDEN.

"The station at Katrineholm I shall never forget, nor the dinner that I had there. I was exceedingly hungry, having started early in the morning, and when the guard cried 'tjugo för middag' (twenty minutes for dinner) I lost no time in making preparations. On entering the *matsal* (dining room) I for a moment forgot my hunger, everything was so different from what I had before seen. In the center of the room was a long table, with a snowy white table-cloth, upon which was seen the most tempting food imaginable, all smoking hot, having just been taken from the oven. At one end of the table were two tureens, one of soup and the other

of buttermilk, the last a favorite dish in Sweden and of which many partake before their soup. Beside these tureens were piles of warm plates, knives, forks, spoons and napkins. Each traveler who was desirous of dining helped himself or herself to a plate, etc., walking around the table, selected what best pleased the appetite, then seated himself at one of the small tables around the room. After soup came fish, then roast beef, lamb, chicken, vegetables, jellies, puddings, bread, butter, cream and coffee. One could eat all he wished, help himself a second time if he desired to, and the price of a dinner, five or six courses, was only 1 krona and 50 öre, about 40 cents. Those who did not wish a full dinner helped themselves from the *smörgåsbord*, or to a cup of coffee from a coffee urn. There were no waiters running to and fro, no crashing of dishes, no noise or confusion in any way. Each person went to the desk and paid for what he had eaten, either the dinner from the *smörgåsbord*, from which a good meal of cold meats, bread and butter, for 50 öre (13 cents), or for a lunch of coffee and cakes. The word of each person was taken, and there were no waiters to watch to see what each had eaten. I never enjoyed a dinner more, and I thought how pleasant it would be to have similar restaurants in America."—*Foreign Letter*.

#### BREAKFAST FOR 10,500 PEOPLE.

"The High Sheriff of Lancaster, Mr. James Williamson, of Ryelands, in that county, has marked his assumption of office by a profuse and princely hospitality. On the 11th of last month, the date of his state entry into Lancaster, he entertained 10,500 people of the town and neighborhood at a public breakfast in his park at Ryelands. Mr. Williamson—who we may note *en passant* is a commercial millionaire—being a native of Lancaster, determined that his open-house hospitality should be dispensed by a local caterer, and accordingly entrusted the monster job to Mr. S. Ducksbury, of the County and King's Arms Hotel. From

all we can hear, that gentleman rose to the occasion, and carried the whole affair through in a most satisfactory manner. As showing the extent and magnitude of the arrangements, we may mention that the crockery alone weighed in the aggregate thirteen and a half tons, and numbered 13,000 plates, with glasses and dishes in proportion, two glasses being placed to each guest. The cutlery, which weighed over two tons, was supplied, we learn, by Messrs. Jennison, of the Belle Vue Gardens, Manchester. To superintend the cooking arrangements, Mr. Ducksbury hired the services of two competent *chefs*, the Brothers Mackenzie, of Liverpool, and three weeks prior to the occasion they were installed in Lancaster, supervising the erection of special culinary plant. Large vats, heated by steam coils, were provided for boiling, as also a fish-steaming apparatus, capable of holding thirty salmon at a time. There were 200 dishes of salmon, the whole 'masked' with mayonnaise sauce. As the meats were cooked they were stored in a large shed fitted with rack shelving, which, had it been placed end to end, would have reached two miles. The stock from the boiled chickens, tongues and other meats, together with waste, trimmings, etc., was cleared away as fast as produced by the poor of Lancaster. The viands comprised: 2,000 pounds of salmon, 80 rounds of beef, 80 pieces of pressed beef, 80 ribs of beef, 80 galantines of veal, 100 Melton Mowbray pies (8 pounds each), 100 meat pies (various), 100 boiled hams, 250 tongues, 400 roast chickens, 200 boiled chickens, 20 game pies, 20 spring pies, 40 turkeys, 500 ducklings, 300 fruit tarts, and 250 open tarts. Some 5,000 bottles of wine—champagne, port and sherry—were consumed, part of the former being Pommery. The waiters numbered 140, and with assistants, washers and others, totalled a staff of about 350.

"In order to provide the required accommodation for the guests five marquees were erected in Ryelands Park. These tents were placed in the form of a square, leav-

ing a considerable space in the centre. The tables ran the length of the tents, but had divisions in the centre for the accommodation of the waiters. The space between the tents was barricaded, the public not being admitted to the central enclosure. At the back of each tent, and communicating with it, was a smaller one for service purposes, and which was in immediate communication with the food and wine stores—two tents adjoining each other and occupying the centre of the enclosure: In the latter a telephone communicating with the County and King's Arms Hotels, so that in the event of anything being unexpectedly required, it could be obtained with the least possible delay. The intervening space between the several tents and stores was utilized for the waiters and staff of women who had been engaged for washing up, and for which water from the town had been laid on to the enclosure, and a portable steam engine fixed for heating purposes. The hot water was run into large tubs, so that there was an abundant supply constantly available. Behind each waiter's tent a knife-cleaning machine was fixed with a man specially appointed to work it. Nothing seems to have been omitted which could in any way contribute to the comfort or convenience of the guests and the speedy satisfaction of their wants.

"In the High Sheriff's marquee, devoted to the local clergy, gentry and tradesmen, was served a sumptuous repast, the *menu* being as follows:

POISSONS.

Mayonnaise of Salmon.  
Soles en aspic. Potted Shrimps.

GROSSES PIECES.

Spring Pies.  
Rounds of Beef. Ribs of Beef. Roulades of Beef.  
Quarters of Lamb. Galantines of Veal  
Roast Chickens. Boiled Chickens.  
Boned Turkeys. Hams. Tongues.  
Various Meat Pies. Roast Ducks.  
Melton Mowbray Pies.  
Dressed Crabs. Dressed Lobsters.  
Prawns en Pyramid.  
Tomato Salads.

ENTREMETS SUCRES.

Fruit Tarts. Pastry, various.  
Jellies. Custard, etc.

DESSERT.

"The tents for the general body of visitors were filled by relays, but good order was maintained, and, thanks to the excellent arrangements of Mr. Ducksbury (whose efforts were ably seconded by his three sons), the feasting of the whole 10,500 guests was got through in about 3½ hours.

"In these tents the *menu* was as follows:

POISSON.

Salmon.

GROSSES PIECES.

Pressed beef. Rounds of beef.  
 Ribs of beef.  
 Various meat pies.  
 Roast chickens. Boiled chickens.  
 Hams. Tongues.  
 Quarters of lamb.  
 Roast ducklings.  
 Melton Mowbray pies.

ENTREMETS SUCRES.

Fruit tarts. Tartlets.  
 Stewed fruit, etc.

"On the conclusion of the feast, the broken meat and fragments of all kinds were distributed among the assistant waiters, the washers, and others.

"Needless to say, there was much effusive toasting of the High Sheriff and his family, whose magnificent hospitality may be said to have created a red-letter day in the annals of Lancaster. Regarded as a mere catering achievement this public breakfast was remarkable, and that it should have passed off so smoothly and successfully redounds not a little to the professional credit of Mr. Ducksbury, his *chefs*, and, in fact, all concerned in the carrying out of a very big job."

CATERING AT THE MANCHESTER EXHIBITION.

"The Manchester Exhibition refreshment contract, one of the biggest ever undertaken, which, it will be remembered, was secured by Mr. A. Mackenzie Ross, of the Café Royal, Edinburgh, is now in full working order. The accommodation allowed by the Executive at first proved so inadequate that five additional places have now been provided, one of the new bars being nearly 100 yards long. Some idea of the magnitude of the contract may be seen by an early visit to the culinary section, where from 6 till 9:30 a. m. a constant pro-

cession of carts wait their turn to get unloaded at the various shops in the stores—the lorries of Messrs. Salt, the Burton brewers, with hundreds of hogsheads of their beer, being conspicuous among the number. Of bottled beer, Messrs. Salt supply on an average from 1,500 to 2,000 weekly. One of the most extraordinary and interesting facts connected with the refreshment department is the demand for tea and coffee. Nightly crowds have to wait their turn at the tea and coffee rooms, which hold close on 7,000, and the quantity gone through during a recent week amounted to nearly 1½ tons of tea, equal to over 20,000 gallons. Among the other edibles which Mr. Scott, the head of the *chefs*, puts through his hands, may be mentioned from 4,000 to 5,000 lbs. of butcher meat per week; 1,000 head of game and poultry per day; 100 stone white fish besides salmon per week; 300 gallons of milk and cream per day; and 4,000 4-lb. loaves per day; irrespective of biscuit, fancy bread, and fruit. To overtake this work, Mr. Ross has a staff of over 1,100 people engaged under him."

HOW 30,000 CHILDREN WERE FED.

"We have received from Mr. P. C. Javal, of the firm of Spiers and Pond, Limited, detailed particulars of their "general scheme" for the supply of refreshments to the 30,000 children who assembled in Hyde Park on Wednesday, June 22nd, to celebrate her Majesty's Jubilee. So successfully did the caterers carry out their onerous undertaking, that Mr. Felix Spiers was personally thanked by H. R. H. the Prince of Wales for his share in contributing to the success of the fête; Mr. Javal also, whose duties held him in another part of the ground, received a letter by command of the Prince to the same effect. That these distinctions were honestly merited will become evident from a glance at a few of the items on record.

"To cater perfectly for such an immense assembly of juveniles necessitated special arrangements, and from 6 o'clock on Monday morning to 10 a. m. on Wednesday

the work of preparation was carried on continuously at the central offices of the firm.

“To supply the requisite comestibles, the resources of several firms were called into action by Messrs. Spiers and Pond. The gross quantities given are as follows: 27,700 meatpies, all of which were made by Messrs. Spiers and Pond; 56,000 buns, provided equally by Messrs. Hill and Son, of Bishopsgate Street, and Carl Fleck, of Brompton Road; 27,700 cakes, made by Spiers and Pond; 27,700 oranges (selected and examined to ensure perfect condition, it being late in the season for this fruit), supplied by Butt and Son, of High Street, Kensington, and Covent Garden; 9,000 gallons of lemonade and gingerade, produced equally by Norrish and Culverhouse & Co. No less than 5 tons of ice, moreover was supplied; knives, cups, mugs, paper bags etc., were of course provided in thousands.

“It is scarcely necessary to observe that all the refreshments were made of the best materials, the meat pies being prepared from the best parts of cattle slaughtered upon the special premises of the catering firm. After they were baked, each pie was uniform in size, weight, etc., and was cooled in the ice-houses of the establishment; they were then each wrapped in small grease-proof bags. These bags were made up into parcels containing 200 each, and put into boxes. Each of these boxes in its turn was numbered to correspond with the tent to which it was consigned for delivery in Hyde Park. This done, the boxes were ready for the wagons or vans, which also bore the number of the tent they were to be sent to in the park. The cake was packed up and loaded in a similar manner. The ten vans, one for each tent, were drawn up in front of Spiers and Pond's premises at six o'clock on Tuesday evening to receive the boxes containing the food, as well as the napery, cups, etc. It took until midnight to load the conveyances. At two a. m. they started in procession direct for Hyde Park. To prevent any possibility of

their being looted on the way by the crowds which even at that hour thronged the streets looking at the illuminations, a policeman escorted each van to the park, where they arrived about three o'clock in the morning, picking up on the route the carts with the oranges from Covent Garden, and from the bakers with the buns. Early as the hour was, the corps of 250 waiters were in readiness to receive the carts and vans, which were immediately unpacked. Next followed the opening of the boxes, and the putting up in big paper-bags of—first, the bag containing the meat pie, then an orange, a piece of cake, and a bun in each one. When this was completed, all the bags were piled up in lots of 250 upon the tent-tables ready for instant distribution. The lemonade and gingerade for drinking was made on the spot in large hogsheads, of which there were twelve apportioned to each tent. Huge ladles were planted in readiness to dip the liquor out into the cups and mugs from which the children drank. In addition to all this, water-carts, lent by the Office of Works and by the military authorities, were attached to every tent to supply pure drinking-water to those who preferred it. A large block of ice was placed in each hogshead to aid in keeping the drinking supply cool.

“There were ten refreshment tents, numbered 1 to 10, each 140 ft. long by 40 ft. wide, and to each was apportioned a superintendent and twenty-five waiters, reinforced by a volunteer staff of ladies and gentlemen.

“Each school knew the number of the tent to which it was to proceed, and, having marched thither, drew up outside. Then, in their turn, the children, in batches of 250, proceeded into the tent and received a paper-bag containing the food already described, together with a cup of lemonade or gingerade, as was preferred. In this way the children, assigned beforehand to each tent, were very soon all served. Luncheons were also spread in the extra tents provided for the musicians and bandsmen, etc.

"The provision was quite adequate to the occasion, and the "reserve" was not drawn upon, so that the collected remnants from the feast formed a substantial donation to Dr. Barnardo's Home for Destitute Boys.

"We have noted the above facts as an illustration of perfect organization and good management, and have pleasure in placing a matter of practical value to caterers as a body on permanent record.—*London Caterer.*

#### CATERING FOR THE MULTITUDE.

"The great popular carnival, Whitsuntide, imposes a strain upon the resources of caterers which outsiders can but imperfectly realize. At the Inventions Exhibition, for example, Messrs. Spiers and Pond were on Whit Monday expected to meet the eating and drinking requirements of over 73,000 people. This gigantic task was, thanks to the masterly arrangements made, carried out with complete success in spite of pessimistic prognostications. At the Crystal Palace Messrs. Bertram & Roberts were prepared to "tackle" a similar inrush. The general average number of visitors to the Crystal Palace to be provided for is 10,000, but Whit Monday is always a special day, and the curious warren of larders and kitchens, bakeries, groceries, butchers' shops, and wine-vaults down at the back of the south transept, was for days previous a very interesting scene of preparation. A correspondent was permitted to walk through the place on the Saturday preceeding the great holiday, and a particularly busy scene he found it. The contractors were prepared for a nice little tea-party of 4,000 people at one time. They can seat this number at any rate—perhaps some at dinner and some at tea. They expected to brew some 5,000 gallons of tea and coffee, and in one room were several huge boilers and some hundreds of tins like large-sized waterpots in which the beverage is run away on trucks to various parts of the palace. They were providing for about 15,000 shilling teas, and their preparations for dinner suggested nothing short of a

protracted siege about to commence. Some twelve tons of meat would be required and about twenty women were busily employed in peeling potatoes, washing cabbages, making salads, and so forth. The firm make and prepare pretty nearly everything here, including various kinds of aëreted drinks, the water for which is pumped up from an artesian well in the grounds and elaborately filtered on the premises. The bottling machinery is very extensive, and the laundry down in this queer region is fitted up with all the most modern appliances, the establishment having in stock something like 20,000 dinner napkins and 5,000 or 6,000 table-cloths. On the Saturday there were four men making nothing but pork-pies, and the quantities of Crystal Palace cake stowed away in readiness for visitors was something prodigious. The ordinary staff of this huge culinary establishment is about 500 people. On Bank Holiday those employed about the place in one way or another was double that number."

#### STEWARDING FOR THE SULTAN.

"There are over six thousand persons, says the *New York Herald*, fed three times a day at Dolma Bagtche Palace while the Sultan is there. To keep all this great machinery of supply in perfect order, so that no matter how many mouths there are to fill, nor what sudden caprice may seize the Sultan, or any of his numerous women, it may be instantly satisfied, is a tax upon the best capacity, backed by unlimited money or credit. If the caprice is not gratified as rapidly as it is formulated, the officer whose duty it is to provide for it is almost certain to lose his position, if not his liberty and belongings, for there is a fashion of long usage in Turkey which confiscates any disgraced official's possessions. The Chamberlain (manager) is mostly occupied in ministering to the wants and caprices of the Sultan, and is in almost constant attendance upon him, so the Treasurer of the Household (steward) has the burden of the housekeeping on his burly shoulders. He has an organized force of buyers, who are

each charged with the purchase of certain supplies for their individual departments, each having his helpers, servants, and slaves. One man is charged with the duty of supplying all the fish, and as to furnish fish for certainly six thousand persons is no light undertaking in a place where there are no great markets as there are in all other large cities, he has to have about twenty men to scour the various small markets and buy of the fishermen, and each of these men has two others to carry the fish they buy. It requires about ten tons of fish a week. There are nearly eighteen thousand pounds of bread eaten daily; for the Turks are large bread-eaters, and this is all baked in the enormous ovens situated at some distance from the palace. The kitchens are detached from all the palaces and kiosks. It requires a large force of bakers to make the bread and another to bring it to the palace and another force of buyers who purchase the flour and fuel. The bringing of most of the wood and charcoal is done by the unhappy camels, who carry it on their backs. The rest comes in large caiquer. The Turkish bread is baked in large loaves, and is light, moist, and sweet, delicious bread in every way, particularly that which is made of rye.

"The food for the Sultan is cooked by one man and his aids, and none others touch it. It is cooked in silver vessels, and when done each kettle is sealed by a slip of paper and a stamp, and this is broken in the presence by the High Chamberlain, who takes one spoonful of each separate kettle before the Sultan tastes it. This is to prevent the Sultan's being poisoned. The food is almost always served up to the Sultan in the same vessels in which it was cooked, and these are often of gold, but when of baser metal the kettle is set into a rich golden bell-shaped holder, the handle of which is held by a slave while the Sultan eats. Each kettle is a course, and is served with bread and a kind of pancake, which is held on a golden tray by another slave. It requires just twice as many slaves as there are courses to serve a dinner to him. He usually

sits on a divan near a window, which looks out over the Bosphorous, and takes his ease and comfort in a loose *pembazar* and *gegelik* with his sleeves turned up. After he has eaten all he wants, the Sultan takes his coffee and his chibouk and lies back in an ecstasy of enjoyment and quiet reverie, which he calls taking his *keif*. Woe be to the one who comes to disturb it! The Sultan never uses a plate. He takes all his food direct from the little kettles, and never uses a table and rarely a knife or fork. A spoon, his bread or pancake or fingers are far handier. The whole household is at liberty to take meals where it suits him or her best, and thus everyone is served with a small tray, with a spoon, with a great chunk of bread, and the higher ones only get the pancakes.

"The Sultan has a number of very large farms, some of them covering miles in extent, both in European Turkey and Asiatic Turkey, and they are intended to supply all those things which farms can produce to the palace. They do not grow rice, and, in consequence, buy nearly one ton of rice per day for the inevitable pilaff, six hundred pounds of sugar, as much coffee, to say nothing of the other groceries, fruit, vegetables, and meat. Rice and mutton and bread form the greater part of the food for the majority of Turks; yet, aside from these, they get away with one ton of beef and half a ton of veal per day, to say nothing of the other viands and fish, sweetmeats, confectionery, nuts, and dried and fresh fruits. The waste and extravagance in the kitchen are enormous, and enough is thrown away every day to maintain a hundred families. Much of this is gathered up by beggars, and the dogs eat the rest.

It is estimated that the annual cost of the food received for the Sultan's household, horses and animals, aside from the value of the product of the vast farms, is very nearly if not quite..... \$5,000,000  
 Cost of furniture, bedding and carpets... 3,000,000  
 Drugs, women's clothes, jewels, cosmetics 10,000,000  
 Aprices of all kinds..... 15,000,000  
 Sultan's clothes and bedding..... 2,000,000  
 Sundries, presents, and servants wages... 4,000,000  
 Plate, gold and silver dishes..... 2,500,000  
 Carriages, 474 of them..... 474,000

Total..... \$41,974,000

"That is a snug little sum, but it is an under rather than an overestimate."

#### THE ARMY HOSPITAL STEWARD.

The army steward is like the under steward of a steamship. He is subordinate to the surgeon of the ward, who acts as upper steward in some respects. The hospital steward has his cooks and assistants and has charge of the preparation and serving of meals and care of patients, beds, etc.; he makes his requisitions for rations and supplies and presents them to the surgeon for approval and signature. At every permanent post there is a store-room in charge of a commissary, which greatly resembles the store-room of a hotel, except that it contains a much smaller variety of goods, and the requisitions are here presented and the goods issued to officers' messes and ward patients and are booked and accounted for to the quartermaster, much the same as under the hotel system.

#### EXPOSITION CATERING—WHAT IT COSTS TO CATER AND WHAT THE CHANCES ARE FOR PROFITS.

Atlanta, Ga., Oct. 17th, '87.—Here is a great business which is entirely unrepresented in American journalism, and carried on entirely without system, almost without understanding; a new set of moths flying at the dazzling flame and coming out singed every year. This letter to the *HOTEL WORLD* is written on the grounds in the half-way period of the Exposition at Atlanta, the best week yet to come, the weather the most favorable possible, and everything propitious to the utmost success, therefore I have no croaking predictions of financial disaster to make in this case, but am impressed with the vast disproportions of the risks to be run to the possible profits of a dining room and restaurant enterprise at such a fair when undertaken under the conditions which are now generally imposed. Undoubtedly the directors of these temporary fairs ought to award the dining room privileges free to the best and most responsible party that would accept, instead

of exacting a heavy bonus and sure pay, cash down in advance, as they do, throwing all the risks of failure from bad weather, non-attendance of the public, fire, or other mishaps, upon the venturesome refreshment contractor; and undoubtedly they would, if the risks and difficulties to be met were better understood and some of the delusively exaggerated idea of the profits to be realized from serving cooked meals were dissipated by actual exhibits of losses and gains in different instances; for the directors would be compelled to provide dining places for the crowds which they induce to attend their shows, and it is nothing but the infatuation of inexperience that impels men to pay thousands of dollars for the wretched privilege of expending thousands more in fitting up one or two hotels on the grounds, with all the incidental entailments, all for the grand reward in view of a probable two weeks' business. Messrs. Directors! I wouldn't pay you ten cents. There is no adequate profit in serving meals alone under such circumstances.

Big money is occasionally made by exposition catering, but it is under certain favorable conditions, such as the being in a very large city; having exclusive privileges; owning every refreshment stand on the grounds; the contractor being permanently provided with portable ranges, tables, silverware, crockery, linen, and the thousand miscellaneous wares, always ready for such employment, and understanding the business and all its risks. The number of disasters that occur is, however, so much greater than the successes as to scarcely justify a comparison being made, yet, if better reported, they might warn the fresh crop of enthusiasts and keep some of them out of trouble; as, for example, these following:

At the Cotton Exposition, which took place at Atlanta a few years ago, two gentlemen in the restaurant and hotel business on the grounds lost ten thousand dollars each, according to common report. One of these, Mr. Pease, is not known in hotel

circles, but he had a local name and reputation, somewhat of the factitious order, perhaps, as an able restaurateur. He conducted the exposition dining rooms, did business enough, apparently, fed the people, but failed to get his pay through having no system of checking. He had long tables, and the people crowded in at meal hours, and many either went away without paying at all, or paid the waiters, or dropped the money into any open hand that happened to be held out to receive it. The other loser built the exposition hotel, and failed to secure patronage commensurate with his expenses. His financial disaster probably changed the current of his life. He is one of the most amiable of men, and his name was once exceedingly prominent as a rising hotel keeper, but ever since that disappointment he has retired to his Virginia estate and cares no more for exposition follies.

Another ambitious man in the hotel keeping line was brought down through an unfortunate catering venture in Kansas City several years ago. His name was Seigmundt; he kept a hotel on the European plan and received so much praise in various ways that it made him want to own all the hotels in the city, and he planned to build a new one that should be larger than all the others combined. Just then the Kansas City bridge across the Missouri river was finished; the railway companies and the city combined to give an immense celebration of the event, and the city council or committee in charge awarded to Seigmundt the contract for a barbecue feast to be provided for ten thousand people, fully fifty thousand strangers being expected, and the barbecue being calculated upon as one of the aids in providing for such of the crowd as could not find other accommodations. The event came off and the barbecue proved a most indescribable failure. Seigmundt did not understand what he undertook. There was no water, no bread, no more cooked meat than would serve for a few hundred, only some raw carcasses rolled about in the dirt, and a

crowd angry enough to have started a riot but for strong restraints. Seigmundt was utterly crushed. He not only lost the money, as he could not claim payment on his contract, but his courage was broken; he left Kansas City and went to Galveston, where he died not long afterwards, in all probability a victim to the mania for undertaking great catering enterprises which so often overcome the inexperienced. But nearly every reader of this article can tell of such instances. I will only add a local example of small size. The man who had the refreshment privileges at the Georgia state fair at Macon last year came out six hundred dollars loser, and if the amount was small it was borrowed money and he was a poor man, and consequently was sufficiently serious for him.

#### CATERING AT THE PIEDMONT EXPOSITION.

If anything can be made in a dining room and restaurant enterprise on the fair grounds, when everything is favorable to success, the venture at this place ought to turn out well. I write now of the eating department exclusively, for the liquor or liquid privileges were sold separately and do not affect the following exhibit of expenses incurred (liquors, by the way, are known by different names in the Atlanta prohibition *patois* from those common in the freer portions of the country)—and only cigar selling is included as an aid to pay the first grand tax. The gentlemen interested have the advantage of both hotel and mercantile experience; they know how to buy and where to buy the best and cheapest. The privileges sold to these parties as the highest bidders, were to run a dining room on the regular meal plan, meals not to be charged higher than fifty cents, and to run another on a different part of the grounds on the *à la carte* plan, all dishes bearing a distinct price. Both of these places are now running. The dining room is just what the name implies. Persons approaching the door find a ticket seller in the way, they buy their tickets, paying, of course, in advance for their



meal; then at the door they deliver the ticket to the doorkeeper and pass in when the headwaiter directs them to seats at one or other of the tables. A good ordinary meal is served without a bill of fare, consisting of about three kinds of meet, half a dozen vegetables, three kinds of sweets, that is, pudding and two kinds of pie, and ending with coffee or tea; bread, butter, pickles, cheese and such oddments being of course supplied without stint. The other place is like your Chicago Oyster House, a good bill of fare is found upon the tables, oysters, fish, game, made dishes and steaks, chops, etc., in variety are cooked to order, and parties can spend as much as they please; the prices are high enough to make the place sufficiently exclusive and so all kinds of people are suited. To secure the pay under this plan where every dish bears a different price and there can be no prepayment, the plan is to have the waiters pass a desk where a clerk counts up the amount on their tray, gives a ticket to go with the order and drops a duplicate ticket into a locked box. The customer takes the ticket to the cashier and pays as he goes out, and at night the clerk's box of tickets and the cashier's tickets and cash are expected to correspond in amount. This is all a pleasant and smooth sort of a business when once fairly in running order, but it is calculated to appal a lazy man at least to contemplate the work that must be done in the short limit of three or four weeks to equip and commence operations in two such places, the carpenters being still at work building them, and then to think that after the finish they are but to run twelve days. It will be useful to some who have never been through the mill to read over a list of only the principal things that must be done for such a spurt of business. We have here, nearly all bought outright and not hired:

Two hotel ranges, each one fire and two ovens, one of them new, the other bought cheaply.

One ten-foot oyster and chop range to burn charcoal, made to order; ten feet of

heavy gridirons, cupola, four flues and smoke stack and expenses of putting up.

One three-foot broiler, new.

One carving table, new, with dish warmer and water heating attachment, made to order, with tin-ware steam chest utensils belonging.

One wooden water tank for range, made to order, and expenses of fittings.

Two wells dug one at each kitchen door, and equipped with frames, pulleys and buckets.

Two small pantries partitioned off from kitchens, fitted with shelves, doors, locks, etc.

One store-room fitted with shelves, meat hooks, locks, etc.

Two butcher's meat blocks, one for each place.

Two refrigerators, not new.

Two new meat saws and cleavers.

Eight kitchen and dish-tables, common.

Eight dish-washing tubs fitted with drain pipes.

Two dish racks erected on whole side of dish rooms.

Four tin boilers with faucets and strainers for coffee and tea, average ten gallons each.

Six tall tin boilers for boiling hams and for general purposes.

Three eight-gallon sauce-pans with lids, made to order.

Fifty oyster and other sauce-pans.

Two large potato fryers.

Six wire broilers.

Twelve fry and omelette pans, various sizes.

Thirty-six tin pans, all sizes, including strainers, etc.

Spoons, ladles, dippers, skimmers, in variety.

Fifty dining tables, six-seat size, new.

Four hundred and fifty split-bottom chairs, new, made to order.

One hundred and fifty white damask table-cloths, new, hemmed.

Two thousand linen napkins, new, hemmed.

Thirty-six plated castors or cruet stands.

Three hundred sets plated knives, forks, spoons, cups, saucers, plates, dishes, butter chips, creamers, salts and tumblers, all bought outright.

Thirty-six waiters' trays.

Twenty-four water-pitchers.

Eighteen gasoline lamps or torches for use at intervals when electric light is not in operation.

Sign painting, kalsomining, bunting decorations, evergreens, sign-card printing, ticket printing, bill of fare printing.

Thirty feet of show cases, rented.

Telephone connection and instrument, rented.

Wagons and drays hired, between fifty and one hundred at a dollar a load—exposition prices.

Two headwaiters and thirty side waiters hired for the fair at extra rates of wages.

Two head cooks and twenty-six kitchen hands.

Six cashiers and clerks beside proprietors, counting one in store room and one at cigar stand.

Insurance on four thousand dollars worth of property and stock including cigars at special risk rate of  $2\frac{1}{2}$  per cent.

"Fore-warned is fore-armed." The above shows the principal bulk of the burden to be taken on before business can be begun in the line of exposition catering. Fuel, imported New York meats, game, shell oysters, fish, bread, butter, the hundred miscellaneous items of provision, have to come afterwards.

In competition with these two dining establishments the fair directors also licensed, and our proprietors by their contract agreed to, a large barbecue hall, where sliced roast meat and bread can be obtained at low price; and also twenty lunchstands, where coffee and sandwiches, cakes, pies, fruit, etc., are sold, so that our larger hotels are far from enjoying a monopoly.

The weather thus far has been perfect and the crowds in attendance large. The best week is yet to come.

Atlanta, Ga., Oct. 31, 1887. Now that the Exposition is over, the questions of everyone I meet, of course run about this way: "Well, how did you come out?" "Did they make anything?" "What luck did you have?" "How much money was made?" In replying to questions of this sort one must know how to stop short of meddling with private business. From that consideration I did not give the prices paid for the many articles enumerated in the former letter on this subject—a list intended to be permanently useful as showing what is required in preparation for such a business—and as to results, it can only be stated that they are like those of a closely contested election. A week after the event the returns are not all in, and the proprietors after all their good book-keeping do not yet know how they came out.

The sanguine calculation was made that there would be twelve days of business and four nights. When the time came these promised periods were whittled down at both ends and in the middle till they lacked about one-third of being full measure, for the two first days were but of the preparatory sort and little business was done; then there never was much breakfast business, nothing done until the middle of the day. If a great many took dinner they left the grounds before supper except on the four nights when there were fireworks, then there was a rushing supper business as well as dinner, but after the fireworks, nothing, for the people rushed off the grounds in the greatest possible hurry. Then came two rainy days, but as they were the big days of the fair the eating-house interests did not suffer, for the people came over a hundred thousand strong, some of them wading through mud nearly up to their waists—at least they looked just that muddy—and the eating-houses were taxed to their utmost capacity to feed them all; but the day after that came nobody and the day was a lost one to business; the closing days were like the opening, poor and unprofitable.

The proprietors were not, however, de-

pending on a single team to pull them through, they drove a four-in-hand. They had paid in advance one thousand dollars for the "privilege," and found that they had the privilege of selling drinkables as well as eatables; they fitted up two places in imitation of bars in connection with their two dining rooms and stocked them up with rice beer, nerve tonic, soda choctaw blood balm, swift specific, and rheumatic cure, drinks which Atlantians and all southerners seem to be passionately fond of, and as these were sold at ten cents a drink for rice beer, which was the lowest, up to twenty-five cents for soda choctaw, the revenue derived from them was very satisfactory in amount, although there were a number of druggist clerks required to be paid for attending to the business not enumerated in the former list of hands employed.

The cash receipts from all four places combined, that is, from the dining hall, the oyster house and the two drug counters, amounted on the best day of the fair to over twelve hundred dollars for that one day. On average days the four places yielded pretty evenly about two hundred dollars each. The dining room where fifty-cent meals were served, as described in the former letter, did the most business, having a steady run of custom from the exhibitors and attendants as well as visitors, and usually served about four hundred dinners; one day served fifteen hundred meals, and this was all done with a one-fire range, a broiler and steam chest with steamers; a large part of the meats were cooked in the night by a special night cook, and bread was bought from a steam bakery.

I have written for the HOTEL WORLD this outline sketch of what exposition catering consists in, and what may be expected as the outcome, believing that even this will be better than no guide at all for those who may contemplate embarking in such an undertaking. Without going into further detail it will be fair to assume that:

This was as successful as such an affair ever can be.

The planning and furnishing was done with the utmost intelligence by men who knew what they were about.

Good wares were purchased that they might be good enough to sell again.

The amount of business done was as much as could be expected where a monopoly of all could not be secured.

The expenses were enormous.

A crowd of hands had to be paid enhanced wages and boarded where provisions cost enhanced prices, through the general demand of the time.

A great risk was run of the whole period being rainy—as the following week really was—and a consequent dead loss through the lack of visitors to the fair.

If the amount of profit made was large enough to be interesting it would not take a week or two to find it out.

If the thousand dollars exacted for the "privilege" had never been paid, as it ought not to have been, the proprietors might have realized something worth their trouble, anxiety and outlay.

If they have made anything it is very likely to be found tied up in the ranges and furniture, which now have to be sold as best they may be. There is just one more conclusion to be drawn, and that is that a great many people, fair directors among others, think that a thousand dollars taken in for the sale of meals is nearly all profit. The fact is, provisions cost something; our proprietors paid Beinecke, the New York butcher, \$370 for only one shipment of meat for their exposition dining rooms and restaurant, which outlay was, of course, for only a comparatively small portion of the material used.

#### TRAINING A STOREKEEPER.

Old Colonel Vesey was standing by when I was trying to instruct Tom, our storekeeper, how he must do to meet the views of the hotel company and especially the company's very exact and methodical book-

keeper, and the Colonel, who was an ex-hotel keeper himself, having run the only tavern in Wayback for a number of years before, dropped the remark that he "did not see the use of keeping store-room books, anyway; that he had never kept any." That was just the sort of remark that Tom liked to hear, for he was nothing but a gay and noisy young fellow, who wanted to do no more work than necessity compelled him to do. He liked well enough to sit in the store-room with a dime novel ready open on the table; to bluff off one who came for stores; tell the next to help himself, and swear when another came for whom he had to reach something down from an upper shelf or open a new package; and he liked very well to use his position to hand out nice fruit and such good things to the pretty girls and withhold such favors from those who did not please him. He had held such positions before in unmethodically conducted houses and imagined that hotel storekeeping was just that playful sort of business everywhere, until he was installed in the store-room of this first-class hotel and then the requirements of the new place bewildered him; and, instead of blaming himself for his want of knowledge of the real duties of the position, he simply said in a self-complacent way that his darned luck had led him to a place where they were nothing but a set of cranks. Colonel Vesey himself was employed in some subordinate position in the front part of the house and meant nothing in particular by his random remark, and Tom did not stop to think that the Colonel's hotel-keeping had not been a success, but had left him in a dependent condition after all. All Tom cared for was to find that somebody shared his views, and made his indignation at the cranky requirements of the company's bookkeeper seem perfectly natural. Consequently this moral support from such an old hotel keeper did Tom a great deal of harm. I had brought him there myself, rather liking his cheerful disposition and thinking that he could be trained to become

a thorough hotel man, and this first-class hotel storekeeping seemed to me to be the finest opportunity a young man could have to get a knowledge of the business from the very foundation. But there was something deficient in Tom's nature. He was lazy. He was too easily discouraged. Goods were sent in by merchants who neglected to send the bills with the goods; Tom declared he could not enter the things in the receiving book when he did not know the prices. Such goods were issued to the different departments and entered in his issue book without the cost prices. His daily account of issues could not be made up correctly. Bills came in to be paid and he had lost track of the goods, could give no account of them. Some goods sent in were billed twice over—that is, a bill would come in with the goods and another for the same goods would come in, either through mistake of the merchants or because it was the regular monthly presentation of bills, and most of the time Tom would enter the second bill as well in his receiving book, which at the end of the month, when everything was added up, made it appear as if he had received a lot of goods which he could not account for. The company's bookkeeper, being as bright and keen as a diamond, never made any quibbles about such blunders, as some might have done, by trying to frighten Tom with the threat of making him pay for these goods which his book seemed to show that he had received and yet he could not produce, for the bookkeeper saw into the mistakes at a glance, but seeing Tom was but a poor stick and a hindrance to the account keeping instead of a help, he mildly advised that he be discharged and a better hand put in his place. But Tom saved us the trouble. All the fun of storekeeping had vanished; he could not even enjoy his novel; he dared hardly give grapes, pears and oranges to the pretty girls in the yard any more for fear the "cranks" would go to weighing, measuring or counting and ask him what he had done with the stuff. So one morning he did not

appear at the store-room. He left the key hanging on my door knob and had run away.

It is all very well to propose to "fire out" a hand who is only half a hand, but in reality hotel keepers, stewards, headwaiters, housekeepers, employers, all are very slow to discharge the help that they can get along with at all. It may be difficult to find the better one to put in the place. There is a chance that the new one will prove worse with some other failing. There are really but few trained hotel hands and none harder to find than real experienced store-room keepers. There are plenty of hands always wanting to work, whole helpless families of them, but what do they know? What can they do? What have they ever learned that is useful? To be a hotel storekeeper it is necessary to know something about accounts and be quick at figures; besides that there is some muscular labor to be performed. We find plenty who can work, but they cannot keep books, and some who can keep books who cannot or will not work with their hands. And a good many poor creatures seeking work say pitifully, "But I can do anything you tell me and shall soon learn." Yes, if we only had time and patience to train every new hand that comes along; but we all have our own duties, tasks and anxieties and want to be assisted, not to be always giving assistance.

However, a store-room keeper had to be found, for business was crowding everybody. No male storekeeper could be found. A young lady was advertising for a situation as assistant bookkeeper. I answered the advertisement, stating what was wanted, and she came and made a favorable impression at once. In the large cities there are numbers of female store-room keepers in hotels and restaurants and they make a trade of it, following the same occupation for years. It is suitable employment for a woman. There is some laborious work about it, but generally some help is available to be called in at the worst times. Mr. Tatillonner—that was the company's bookkeeper, I did not men-

tion his name before because I hate to write long words—intimated that now a new person had taken up the duties it would be wise to train her just right, by which I understood very well that he wanted somebody to fall in with his own special method of hotel bookkeeping, and classify matters and things as they came to hand, all ready for him to transcribe them into his own system of accounts, and I seconded him in his first instructions and explanations as much as lay in my power amidst a rush of hotel business in the height of the season. Steward's and storekeeper's bookkeeping is not the hotel bookkeeping, but only auxiliary. The steward's books must be right and show faithfully the incomes and outgoes of his department before the hotel bookkeeper can make out whether the hotel is making or losing. Technical hotel bookkeeping is learned at business colleges, but after that it is found that different systems are followed in different places. Mr. Tatillonner was a man of superior attainments in that line. He was doing more than keeping the books of the hotel business, he was the accountant of all the company's operations of which the hotel was only one part. He had gained his experience of hotel accounts in establishments belonging to stock companies, like those famous hotels of Switzerland or those immense modern hotels of the English railway companies, where they add up the totals every day, make statements to the shareholders every month and make public statements and declarations of dividends every quarter, and where scarcely so much as a match can be taken, certainly not a box of matches, without somebody having to account for it. So if Tom had thought this man, doing this hotel's bookkeeping with such ideas of exactitude in his head, was a "crank," it may well be supposed that Mr. T. thought Tom was a very poor excuse of a young man, indeed, for knowing next to nothing. So it remained now to be seen how the new storekeeper would get along in the seemingly difficult situation.

The difficulty was only seeming, not actual. In a large establishment each department is but a part of the whole machine; each individual is a wheel, all having to go through their own round in their stated time and not disarrange the works by stopping or trying to run more than their own part. Our new storekeeper had to learn a daily routine according to a special system, and that once understood it was merely a matter of industry and faithful application to duty and success was sure; besides, Miss Massinger—that was her name—liked her new duties; she was prim and methodical in all her ways and had a natural talent for bookkeeping.

In a very large number of hotels, those of small or medium capacity, the storekeeper's duties are much mixed, only a portion of the day at stated periods being devoted to receiving and issuing goods. It may be in such a case our new storekeeper would have filled in the intervals assisting in the pantry or preparing the fruit and cake baskets for table, or attending to the milk and cream. In this house, however, we had ample employment for every hour of the day for the storekeeper in the store-room itself, the very strict bookkeeping required making even more than one could attend to. Early every morning, or soon after the store-room was open, which was half past five, the country people came crowding around with marketing to sell; that made weighing, measuring, counting, booking and giving orders properly signed, dated, stamped and figured up to each one to get the pay on at the office, the sums varying from ten cents to ten or twenty dollars—as when a load of chickens was bought. At the same time three or four hands from the cooking and serving departments came with vessels for various material, which had to be weighed, measured or counted out to them and the amounts entered in the proper column in the store-room issue book, charged to each department, all the issues during the day to be footed up at night. When goods came in from the stores and markets, also

wood, coal, charcoal, ice, milk, all kinds of stores and supplies in fact, the storekeeper had to receive them, see them weighed or counted and entered the transaction; compared the actual amounts received with the bills sent in and marked errors, if any, and disallowed the pay for goods damaged or missing. Then these bills were to be entered in the book the same as the small marketings from the country people, but perhaps in different columns. So one thing with another kept Miss M. fully employed, the hotel doing a lively business at the time, and she seemed to be getting along very well.

Still, at the end of a week I could see there was a hitch somewhere, and I was anxious for various reasons that my new storekeeper should give satisfaction, so I set in to find out what it was. But she hardly knew. It had just taken her two days and part of the nights to take stock, that is to find out at the end of the month how much property remained in the store-room and give the value of it in figures, and this was one thing which had caused Mr. T., the bookkeeper, to give vent to some expressions of impatience. Miss M. thought she had been doing noble work in keeping all the books in correct order and allowing no errors to appear of any description in the accounts of a week, but she said Mr. Tatillonner seemed to expect stock to be taken every night, which was a physical impossibility—so she thought—and said he had remarked that while he was obliged for the sake of his own account-keeping to have a statement of stock on hand every two weeks, yet he should like to have her accounts so that she could tell how much stock remained at any time on an hour's notice, and she added, laughingly, she began to sympathize with her predecessor, Tom, who had run away from it. I had heard him myself speaking to her about a former manager of the house who was so exact in his figures and daily bookkeeping that he could tell every night whether the hotel had made anything that day or lost. Some men have a taste and talent that

way. There is nothing in common between such men as that and such as Colonel Vesey, who despised figures altogether, yet it must be owned the figuring men are the ones who carry on the world's business. There was another thing making the new storekeeper feel incompetent and uncomfortable. The manager of the hotel himself was in the habit of dropping in, after looking over some bills perhaps, and asking what day it was that the last doz. boxes of soap came in and how many bars were being issued a day; when the last tierce of hams was begun of; how much flour was being used a day or week, and so forth. The girl thought her part was done when she had entered everything correctly in the books, and had not prepared herself to answer such questions off hand, though they could be answered by an examination of the entry book or issue book, or both; but the stock taking seemed to her the insurmountable difficulty. "What," she said, "roll about and weigh all those barrels and boxes, those tubs of butter and that greasy tierce of lard every night?" "Nonsense, young lady," I said, "nothing

of the sort; what are your books for; don't they show how much you have given out from a barrel or box every day?" "Yes," said she, "they would if the amounts were singled out and added together and subtracted from the box or barrel, but that would take forever; there wouldn't be time for anything else all day. Oh dear," she continued, about half in earnest, "which road do you think Tom took when he ran away? I may have to go the same route." But I told her there was nothing to be discouraged about; all she needed was one more book specially ruled, which she had not at present, and I would show her how to take stock every evening without leaving her chair, and how to tell at a glance what day, and hour if necessary, any box, barrel or package had been taken in, and how much was used a day, or in an average way, and it would not take up an hour a day to keep it posted to the satisfaction of even such an exacting accountant as Mr. Tatiillonner was proving to be.

Accordingly I obtained a blank book of medium size and ruled it in this way:

STORE-ROOM STOCK BOOK.				STORE-ROOM STOCK BOOK.											
CABBAGE.			CHICKENS.			SOAP.			SUGAR.						
JULY.	RECEIVED.	ISSUED.	REMAINS.	AUGUST.	RECEIVED.	ISSUED.	REMAINS.	JULY.	RECEIVED.	ISSUED.	REMAINS.	AUGUST.	RECEIVED.	ISSUED.	REMAINS.
1				1				1	600 bars.	12		1			
2				2	70			2		8		2			
3	100 head.	10		3	24	60		3		8		3			
4		6		4		50		4		16		4	240 lbs.	25	
5		8		5	108	40		5		8		5		35	
6		8		6		40		6		8		6		45	
7		6	62	7	18	25	5	7		10	530	7		25	110.
8				8				8				8			
9				9				9				9			
10				10				10				10			
11				11				11				11			
12				12				12				12			
13				13				13				13			
14				14				14				14			
15				15				15				15			
16				16				16				16			

# The Store-Room Issue Book.

ISSUED FROM STORE ROOM, *(Left hand pg)*

KITCHEN											KITCHEN										
	1st Issue	2d Issue	3d Issue	4th Issue	Total		Dol.	Cts.		1st Issue	2d Issue	3d Issue	4th Issue	Total		Dol.	Cts.				
Beef, quarter									Brought Forward												
Beef, loin									Peas, split												
Beef, rib roast									Peas												
Beef, tenderloin									Rice												
Mutton, quarter									Barley												
Mutton, racks									Mackerel												
Lamb									Pig's feet												
Veal, quarter									Tripe												
Veal, racks									Salt												
Pork, quarter									Macaroni												
Pork, loin									Corned beef												
Chickens, dressed									Tongues												
Chickens, live									Ham												
Turkeys, dressed									Bacon												
Turkeys, live									Salt pork												
Fish, bulk									Cheese												
Fish, dressed									Oil												
Butter, table									Lemons												
Butter, cooking																					
Lard																					
Oatmeal																					
Cracked wheat																					
Grua																					
Milk																					
Eggs																					
Potatoes																					
Sugar, gran																					
Sugar, pow'd																					
Codfish																					
Cracker dust																					
Corn																					
Tomatoes																					
Cabbage																					
Turnips																					
Parsley																					
Carrots																					
Onions																					
Beans, string																					
Beans, lima																					
Beans, navy																					
										Total											



# The Store-Room Issue Book.

Date..... 188..... *(Right hand page)*

PASTRY & BAKERY								DINING ROOM & PANTRY							
1st Issue	2d Issue	3d Issue	4th Issue	Total	¢	Dol.	Cts.	1st Issue	2d Issue	3d Issue	4th Issue	Total	¢	Dol.	Cts.
Flour								Butter							
Meal								Sugar, cut loaf							
Lard								Sugar, pow'd							
Butter								Syrup							
Eggs								Coffee							
Sugar, brown								Tea							
Sugar, gran								Chocolate,							
Sugar, pow'd								Celery							
Milk								Olives							
Rice								Pickles							
Lemons								Tomatoes							
Cream								Mustard							
Gelatine								Nuts							
Salt								Cheese							
Total								Total							
LAUNDRY & LINEN ROOM.								OFFICE							
Soap								Writing paper							
Blueing								Envelopes							
Starch								Cl. paper							
Total								Total							
HELPS HALL								RECAPITULATION							
Sugar								Kitchen							
Milk								Pastry and B.							
Coffee								Dining Room							
Tea								Laundry							
Syrup								Office							
Butter								Help's Hall							
Total								Total Issues							

The example shows the half-size of two pages; there must be ruled lines enough to take in the 31 days, and the wider the pages are the more items can be run on the same date line, bringing 3 or 4 items in each division where our example shows but one. The names of articles were placed alphabetically in the pages; thus the first page was headed *Almonds, Apples*, the last page *Wine* and *Yeast*; it was easy to find *Ice* in the middle of the book when that article was brought in and weighed, and easy to find *Milk* when that came in varying quantities thrice or more a day, and easy to set down the number of gallons to the left or right of the column, showing the morning and evening receipts. It was found that there were 200 articles of almost daily issue to be given in these pages, such as *Bacon, Barley, Beef, Beans, Brushes, Butter, Buckets*; at two to a page it took up 100 pages or 50 leaves of the book for every two or three months. But still not over 50 different things would be issued in one day, and some days not nearly that many, so that there were often only 20 or 30 items to be transcribed from the issue book, and the quickest way was for two persons to act together. The "Remains" or stock-on-hand column was not necessarily added up daily, but it was found useful to do so as it often reminded the storekeeper

of an otherwise hardly remembered duty, to order more of an article that was getting low, as in the example; the addition and subtraction shows only five chickens left on hand for a houseful of people. But the best of it was that after this, the issues being strictly attended to and punctually entered, the amount of stock on hand, even down to the chicken house and potato cellar, could be told from this book on an hour's notice, and the time when any special lot of goods had been received could be told in a moment. Miss Massinger, as I have said, did not hate figures, her tastes rather led her to find pleasure in them, she saw a clearer way before her after that and I never heard any further allusions to the departed Tom and his example of running away from the store-room troubles. Mr. Tatillonner, without knowing or caring to know how it came about, found his only cause of complaint removed and finds much to praise in the storekeeper—for she still holds the position, being now in the second year—and they have become great friends. Sometimes I think he is teaching her the higher branches of bookkeeping, seeing how very close they set their chairs together and how very long it seems to take them to go over one small page of an account book.

## THE HEADWAITER AND HIS TROOPS.

### THE HEADWAITER.

The headwaiter is an important officer, with forces under his command. When there is a banquet or a large dinner the guests are placed in a position of great peril, liable to come to grief; for there are they famishing; yonder, in the kitchens, bakeries, pantries, dish heaters, refrigerators and milk rooms, is their dinner, unconcerned hanging back, lying around, hiding away. And between the dinner and the guests are all sorts of obstacles and

barriers, such as busy hands and careless hands, funny people and cross people, side interests, selfish aims, bribes, cold drafts, indolence, and long distances. The guests cannot go after it themselves, some of them occasionally wish they could, but their success or defeat in getting their dinner depends upon the headwaiter and the way he manages the troops of waiters under him.

If you would find the soft spot in the nature of the first-class headwaiter, take

notice of his boys; observe the good condition they are in; how neat they look; how they are graded according to size; how promptly they march to their stations; how well they know the bounds of their duties and how firmly and calmly they face all the odds that may be brought against them in the way of extra guests within their own stations, without being in the least distracted by the way the battle is going in other parts of the dining room; each man holding his own post, the commander alone looking over the whole field.

If you would see the headwaiter put off for a moment that look of superciliousness as he stands at the dining room door, appearing as if he were too lofty to be spoken to, speak to him in the same vein his thoughts are running in, of the whole dining room, not of any individual. His apparent superciliousness is not pride of place, it is anxiety. He sees tables which you do not, without waiters and the guests impatient, and he does not care for you at the moment, but wishes he could see through the walls what those absent waiters are doing. And, besides, he is taking note of various strange faces at certain tables, for he has his part to do in watching that strangers pay for what they get, that beats and sneaks do not slip in and out amongst respectable people unobserved.

And, furthermore, accord to the headwaiter his right, which the name of the office defrauds him of, remembering that he is not a waiter, but the head of the waiters, the chief and superintendent of the dining room forces, if you wish for his co-operation, his respect and regard.

And I do not see why you should not. Service is, after all, the principal thing in a hotel, and the headwaiter is the master of that branch. It makes but little difference how well the feast may be prepared in the kitchens if it is not well delivered at the tables. And the headwaiter becomes very much of a gentleman through the training of his position and the force of example in his daily contact. He sees the contrast daily between good breeding and

good manners and boorishness at the table, and he becomes a very good teacher of deportment and a discriminating critic of manners of the other employés of the house. It is the best proof of his own training that the good headwaiter, even if hostile towards some other employés, is never loud in speech and never makes himself obnoxious by violent demonstrations.

The headwaiter dresses well. He is obliged to do so, and is entitled to receive a liberal salary for that reason. The well-paid *chef* wears white jackets, caps and aprons, and light overalls, all furnished to him clean daily or oftener, the laundry work being at the expense of the house, but the headwaiter has no such privileges. For some other employés a fifteen-dollar shop suit of clothes may be as good as they need to wear, but the headwaiter cannot economize in that way. He is obliged, as part of his business, to dress as well as the average of the guests of the house, he is often a model in that respect. He must wear fine linen and unmaculate cravats. It really takes up a considerable salary to keep up a first-class headwaiter's personal appearance. And in regard to the headwaiter's "tips" the subject is much mixed, for it depends upon the kind of man he is whether he receives much or anything in that way, but it is a fact that very few white headwaiters ever receive "tips," unless, perhaps in a general way, the guests make up a purse at the end of a season or at Christmas; and no man in a really first class position ever descends to divide tips with the waiters. There are plenty of floating yokes and sarcasms pointing the other way, but they are all in relation to low grade houses. A first-class headwaiter cannot afford to sell his independent impartiality for a "tip."

Some of them have remarked to the writer: "If I allow them to give me a dollar, as I used to do when I was young, they think they own me and they want ten dollars worth of favors and extra waiting on for it. It is all well enough for the

waiters who can stay with them, but if half a dozen people at as many tables had given me a dollar each they would work me to death calling for extra attentions. No, I never take these bribes—cannot afford to.” However, as before remarked, there are different sorts of men in the business, and some may be influenced by the size of the “tip” offered, and by other considerations to be mentioned further on.

#### THE HEADWAITER'S IMPORTANCE.

The degree of importance of the headwaiter varies according to the disposition of different proprietors, for in some hotels the latter likes to pass up and down through his dining room and circulate among the guests and the headwaiter may have to take a back place. But in nearly all large hotels, particularly in the cities, the headwaiter is the head and front of the dining room, he is the only official the guests come in contact with, and with less restraint than if the proprietor himself were present they make known their wants and complaints to him. There is a vivid picture of the restaurant headwaiter in the sketch of “A Russian Restaurant,” given on a former page. That personage is met with in every European hotel, and is the most prominent figure in every stranger's recollection of the place. He is called not headwaiter, but *maitre-d'-hotel*. In England he is frequently called manager. In this country he is called the inside steward in the European hotel or restaurant or club, and he is the same and his duties are the same as the headwaiter in the American plan dining room. He it is that meets the visitors, sees them located, and if they are in any way special objects of attention, he is the one who hears their orders and sees that they are attended to. In Paris, recently, an incident occurred where two men in shabby clothing, in the garb of laborers, but with money in their hands, went into one of the highest-class restaurants and would have ordered their dinner. The headwaiter (*maitre d' hotel*) said, “Gentlemen, your dress prevents your

getting any dinner here.” They would not be refused, but the police were called in and they were lawfully expelled. In England the law would have sustained them in their demand for dinner in any public eating house. The same would be the case in this country. The headwaiter in an American hotel knows what to do in such a case. He has obscure tables, lower end tables, middle-class tables, upper-class tables and exclusive tables, and he assort- strangers as they come and allots them to their tables according to their appearance or their deserts generally, without their being at all aware of the sorting process they are subjected to. That is what he is at the door for. The dining room is a public one, but with a good headwaiter in charge no dusty, travel-stained or ill-dressed customer will be put to shame by finding himself seated among the exclusives at an upper table. This, however, is only one among the manifold duties of the headwaiter which requires a special kind of ability for its efficient performance.

#### THE HEADWAITER DOES NO WAITING.

It seems worth while to state this explicitly, there being such a general misconception in this regard. A person at table wants something and seeing the headwaiter standing by the door apparently idle motions to him and would send him after the thing desired; but the headwaiter cannot go, he will send a waiter, but never leaves the dining room himself, unless there is extreme urgency. It is true we are speaking generally of the larger and more expensive class of hotels, and proprietors in country towns expect something different, yet if the headwaiter does his duty even in a small house where there are but five or six waiters, it will be found that he does better for the guests and for the reputation of the house by remaining in the dining room to watch; to see who comes in and who goes; where they are seated and whether taken to seats reserved for them or somebody else; to watch the

wants of all the guests at all the tables and not go off on errands for a few.

#### SCARCITY OF GOOD HEADWAITERS.

There never can be very many of the highest type of headwaiters, the requirements of the position are such that not many men combine all the necessary qualifications, and when a proprietor is preparing to organize a force for a new hotel or a resort house there is nothing gives him more anxious trouble, if he be not already acquainted with his man, than the selection of a headwaiter. The reasons for it will be apparent as we proceed. Headwaiters are officers in command of a number of hands and it is necessary that they be able to govern; they are like the centurions of old, commanding a hundred men. One of the large catering jobs mentioned in a former page required the employment of 26 headwaiters; each one had 150 waiters under him, and each had among them his lieutenants and captains. One London firm advertised for 4,000 waiters for some such a big transaction and received applications from 10,000, whether waiters or those who called themselves such. There are plenty of waiters, but only by selection from great numbers can the headwaiters be found. The proprietor may have his dining room force well organized when something happens that the headwaiter leaves and in the ordinary course with almost any other line of business the second waiter would take his place, but it is seldom so here. The second may be able, but not good-looking. It is very desirable that the chief of the dining room should be of good personal appearance. He is the front sign of the house; he is the man the proprietor puts forward to represent himself in the first meetings with the guests; he is to give the first impressions, and they may be lofty or low, buoyant or depressing, affluent or beggarly in a great degree, according to the condition of the official who either ushers or hustles them into their seats.

out all men below a certain standard height, and if it is bad for the little men, the rule is good for the appearance of the ranks on parade. Small waiters may do well enough, but if they run large it comes hard for a stumpy headwaiter to play the peremptory colonel over them. Then there are some men able enough whose countenance would turn milk sour if they looked at it; some so self-absorbed that nobody can receive good greeting from them, nor catch their eye at table; some that look pallid and consumptive or pictures of grief; these are never chosen to stand at the dining room doors. Then some are built to be cowboys, to roam the western plains, rough in spite of themselves and their good clothes, loud and obtrusive without delicacy enough to be aware of it, and these are out of place on the carpet, however well they may do to marshal a battalion of waiters at some great festival in the open fields. It is not advisable either to have a man with a glowing red nose and coarse, blotched face trying the headwaiter's role in first-class dining room; his will may be good, but he is out of place also. And some who do not suffer under any of these disadvantages of a physical nature are deficient in other respects. The too-good man will play with his waiters and loses his authority by placing himself on an equality with them. Or he spoils them by the promiscuous granting of favors, the letting them do as they please. Others are crabbed, capricious and unjust. They make rules one day which they change the next day. A waiter may be blamed and reprimanded by them for doing something today, which was perfectly right to do yesterday, and thus they lose their influence and usefulness. For every sort of inefficiency results in injury to the hotel. Some hotels are so cursed with incompetency in this department in the midst of a busy season, when there is no time for changes, that the business suffers perceptibly and lasting damage is done to the reputation of the establishment. And because of the narrowness of the gate and the strict sifting of men the

In the army there is a rule which shuts

number that gets through into the first class headwaiter's ranks is small and strictly first-class men are hard to find.

#### THE FOREIGN HEADWAITER.

We have in this country certain ways of our own of hotel keeping which may be better than any methods of other lands, but we also have hotels as well as clubs and restaurants which are conducted under foreign methods conformably to a line of conventionalities not to be learned in the American plan hotel, and it is necessary to the making of a thorough inside steward, *maitre d' hotel* or headwaiter to see what sort of men they have as well as what they do in those establishments. In addition to "Monsieur Mezzofanti" of the "Russian Restaurant" article, before referred to, we have here a sketch of another of the high school of headwaiters:

"Everybody knows Bignon's restaurant in the Avenue de l'Opera. It is the rival of the Maison Doree, the Café Anglais and the Lion d'Or. One of its pillars has passed away in the person of 'Henry', the head-waiter, who, being almost an institution in himself, deserves a brief obituary notice. 'Henry' has been called the 'soul' of Bignon's gastronomic establishment, and so he was. He had been there for twenty-six years and knew every foreigner and every Parisian of mark. It was interesting to observe the polished obsequiousness with which he handed the menu to a royal or imperial guest and to contrast it with the more familiar manner in which he tried to coax the appetite of some *blasé habitué* by descanting on the merits of a new sauce, or praising the excellence of some special dish of the day. 'Henry' had raised his profession of head waiter to the dignity of an art. He had only one rival 'Ernest,' the *maitre d'hotel* of the Café Anglais, who was also a paragon in attending to customers. The education of no Paris waiter was supposed to be complete unless he had learned to flourish his napkin, to flit between tables and to carry trays under the guidance either of 'Mon

sieur Henry *chez Bignon*' or of 'M. Ernest,' of the Café Anglais. Waiters who could afford it are said to have had restricted meals at Bignon's for the purpose of studying 'Henry's' movements *de visu*, and it is quite probable that had 'Monsieur Henry' started a *conservatoire* for the education and bringing out of *garçons* and *maitres d'hotel* he might have made a fortune thereby. Had the deceased *maitre d'hotel* been of a literary turn he might have compiled some interesting memoirs. He 'waited' during the declining effulgence of the Empire, when all Paris was mad with riot and revelry; he attended many a *petit souper*, where champagne flowed like water, and he must have seen many a mighty magnate making a fool of himself for the *beaux yeux* of some painted and powdered 'creature' with an insatiable appetite for crayfish and an unquenchable thirst for choice crus."

And here is another:

"Eugène is indispensable to the establishments where the *elite* of Parisian gentry dine. He knows all the customers, is acquainted with their tastes, and with their favorite subjects of conversation. He has carefully studied them, and knows whether to let Mr. So-and-So order his own dinner or whether to give him the advantage of his professional experience. Eugène is always there, and watches the first mouthfuls disappear with a keen interest. His guest could not possibly begin dinner unless Eugène was there to put him in good dining humor. A short chat invariably springs up between Eugène and his customer. Eugène is gay, is amiable, and a *bon vivant*. Accustomed to live in the atmosphere of the most succulent dishes, and of the most generous wines, he seems to have taken the good properties of both. As soon as Eugène has set one customer going, he moves on to another. He rarely takes any notice of a stranger, disdaining an unfamiliar face. If an intruder calls, Eugène contents himself with a sign, 'Louis, attend to monsieur,' or 'Casimir, the wine-ist for monsieur.' There are some customers

who will only be served by Eugène. They even prefer him to the proprietor of the restaurant, who is often obsequious and awe-inspiring. It is specially to high-class parties that Eugène is indispensable. According to the appearance of the guests, he knows what *menu* to suggest. He has summed up your revel at a glance, and knows exactly how much you want to spend. He is never present when the bill is presented. One is always rather suspicious of one's customer, and, not to spoil an acquaintance so well begun, he leaves his guest to wrangle with the waiter. The customer pays and goes away more or less satisfied; but he is certain to come again on the morrow, more attached and faithful to the establishment than ever. And thus it is that Eugène, after ten years' service, in a veritable power in the establishment, deferred to by the proprietor and feared and envied by the waiters."

"He knows all their tastes and favorite subjects of conversation" does he? Well, headwaiters hardly get to that pitch of familiarity in this country. But much depends upon the kind of man he is. One of the present restaurant proprietors of Paris was started in business for himself through the favor of some stock broker customers who liked him. They told him of a good speculation in stocks—gave him a pointer—he took advantage of the information, speculated and realized a small fortune. But the rule works both ways. Another headwaiter at a Paris café, eavesdropping behind the chairs of a couple of stock brokers, thought he had picked up a pointer and went and speculated on the strength of it—for all Paris speculates—but it proved that he had "caught hold of the wrong end of the stick," and he lost his life's savings, \$30,000. How different his case from that of a London boy who was both headwaiter, cook and caterer in a stock broker's office. Some shares in one of the large brewing companies were put upon the market. This boy had been for a good while a sort of private caterer for the brokers' lunch, cooking and serving it

in a room in the rear, making a good profit and saving his money. The brokers applied for a number of shares, as brokers. The boy applied for a number of shares, calling himself a refreshment contractor. There were not enough shares to go around, but the brewing company gave the preference to refreshment caterers; the boy got his shares, the brokers did not. The shares increased in value immensely and gave the young fellow a good start in business.

#### IN AMERICAN HOTELS.

If the headwaiter of an American hotel is to have time to play the "Mezzofanti," the "Henry," or "Eugène," and go around from table to table chatting and so forth, trying to make every guest feel satisfied, it is evident he must have a lieutenant, a second or assistant headwaiter to remain at the door, and whether for that or other reasons most headwaiters do appoint such an assistant, but not all. Somebody inquiring of a trade paper some time back what were the duties of the headwaiter received the following reply, which we will examine and comment upon:

"A headwaiter's berth in a first-class establishment is no sinecure. The man who accepts it takes upon himself many responsibilities little realised by the patrons. He appoints one or more men under him who are called captains. It is their duty to see that the waiters arrive on time each morning and to put the dining room in order for breakfast. The silver, carefully put away under lock and key at night, is recounted and rubbed with chamois and either placed on the tables or on sideboards in the dining room. The glassware is carefully wiped and polished. The linen is brought up from the laundry and counted to see that it compares with the laundress's account. The chairs and tables are thoroughly cleaned and dusted. Windows and globes must be washed, the butter cut or molded into forms and the castors and salt cellars washed and refilled. Every thing must be in place before the

arrival of guests. The headwaiter sees at a glance if the work has been properly done. He inspects the castors to see that fresh oil has not been put into cruets holding stale oil. He lectures the men under him, tells them of the complaints made by guests the day before, and warns them not to repeat the offenses. He details each waiter to attend to a certain number of tables, and when the breakfast hour arrives he throws open the great doors of the dining room and greets each guest that enters with a familiar good morning. Regular guests who are hard to please come under his personal supervision. The guest who objects to drinking coffee unless it is prepared a certain way and the man who will not eat unless served a dainty not on the regular bill of fare are both made happy by this diplomat. He convinces each guest that they have received a dish which he had prepared for them only, and he tries to convey the idea how few there are who receive the personal attentions of the chief of the dining room. His policy not only pleases but it adds to his bank account."

The one giving the reply starts in by speaking of the duties in a first-class establishment, yet in several particulars shows that he refers to hotels of the medium class. He says, for instance, that the headwaiter details each waiter to attend to a certain number of tables, when it is well known that one waiter cannot attend to any great number of tables, in fact one waiter to one table is the rule. However, in times of dull business, when a few guests come straggling in at intervals, one waiter might attend to two or three tables.

He says, also, that the headwaiter appoints one or more men under him who are called captains. In fact, if the headwaiter appoints any captains he will have at least two, one for each watch; if there are more than two watches of waiters—as in a railroad eating house or a café there may be—there will be a captain over every watch.

He says again that the windows and globes must be washed, the butter cut or

moulded into forms and the casters washed and refilled, also the glassware carefully wiped and polished.

Now, all this is called side work, and it all depends upon what terms the waiters are hired upon whether they do side work or not, or whether they do a certain part and not the other part. In most, if not all, first-class hotels, there are regular window washers outside of the waiters, and the butter is cut and moulded by the pantry girl in the pantry, the glass is washed and polished by another hand in the glass pantry. It is not the intention that the waiters shall have idle times and the less to do, but it is supposed and so managed that they shall have all they can do at their proper business of waiting at table. Moreover, they are required to be scrupulously neat and clean and are not expected to do any side work that will soil their clothes. They do, however, count the silver at night under the eye of the captain of the watch, after it has been washed and dried in the glass pantry, and they take it out of the silver closet or safe next morning and polish it before it goes on the tables. They do dust the tables, mirrors, sideboards and chairs, prepare the bowls of broken ice and do all that belongs in the dining room. The remainder of the quotation is "all so" and calls for no remark. The motive for commenting upon any of it is to say that stewards, headwaiters or proprietors sending perhaps to a distance for first-class trained waiters and perhaps pre-paying their fares, are liable to be surprised and disappointed when they arrive by their refusal to do "side work." It is not intended to say that they ought not to do such work; merely to let it be known what may be expected of waiters brought on from the most prominent hotels and resorts. Here is another quoted paragraph to the point:

"Mr. F. P. Thomson, whose resignation as headwaiter at the Vendome has already been made known through the columns of the *Boston Hotel Gazette*, will during the coming winter manage what is probably to



be the largest waiting force of men ever gathered in the hotel business under one head, in his new position as head-head-waiter, so to speak, at the three hotels, Ponce de Leon, Alcazar and Cordova, St. Augustine, Fla. At the first-named hotel, which is to open about Christmas, he will have under him 150 men, at the Alcazar, opening about Thanksgiving time, 50 men, and at the Cordova, to open on January 1, 75 men. While the majority of these men are to be gathered from Boston, New York and Philadelphia, some of his head assistants have already been engaged."

It is not likely that any of the above mentioned force of waiters would hire themselves to do "side work" between their hours of table waiting, but amongst the many classed as waiters there may be some specially hired for "side work" employment. At the same time it is to be distinctly understood by waiters that in the great majority of smaller hotels the waiters do and must take off their jackets and divide up the work amongst them—some fill the castors, some wash glass, others prepare the celery for table, mould the butter, clean windows, scrub porches, even help in the garden, gather fruit and peas, and then help in the kitchen by shelling peas, picking strawberries and the like. Then again, they frequently in the advance of the season do all these things in the way of helping to save expenses while the business is dull, but drop them and quite give up all such work later when they have all they can do in a day to wait on the hundreds of guests. These things should be thought of when waiters are engaged and a distinct understanding had in advance. It may save disputes and strikes and quitting of much needed help at the busy time when it is hard to replace them with others.

#### ORGANIZING THE TROOPS.

The headwaiter's duties have now been pretty clearly outlined, his relations to the steward and *chef* having been defined in the first part of this book. And the differ-

ence betwixt a front view and an inside view may be seen by reference to the extracts concerning the foreign headwaiter, where the writers regard only the personality of the particular "Henry" or "Eugène," his pleasing presence and his chat, without the least intimation in their remarks that at the same time "Eugène" is chatting so pleasantly with them at their table, he is thinking, probably, about a waiter at the most remote table in the room, where perhaps a family just arrived has been seated and requires attention, and divide his thoughts with some other critical customer in quite another direction.

#### WAITER'S UNIFORMS.

The first step in organization for the headwaiter is to dress his waiters all alike—they must have jackets, cravats, slippers and aprons. Ordinarily they have only one jacket, a black alpaca with bright buttons, but in some of the most stylish houses the waiters appear in white jackets at dinner and black at the other two meals. This necessitates their owning two jackets, and puts the laundry work of the jackets upon the hotel. For the waiters have to buy their jackets and own them. The hotel buys a lot of assorted sizes at the manufactories where all sorts of uniforms are made, and each waiter when he hires must buy one of them and pay for it in installments. If the jacket cost four dollars the waiter, when his time is made up on the time book, will have one or two dollars of his wages stopped each month till it is paid for. The same thing is done with light patent leather slippers, the hotel buying them by the box and selling to the waiters at cost. White cravats cost but little and are usually furnished free by the hotel, as well as aprons, which both go to the laundry through the same routine as other white goods, to be counted out and counted in each morning, as indicated above. The waiters must provide themselves with dark-colored or black pants of decent appearance, but at the same time the waiters' aprons are made of such ample

dimensions they almost entirely cover the wearer down to his bright slippers.

#### TELLING OFF THE WATCHES.

When they are all in uniform the headwaiter draws them up in line like soldiers in the dining room and assorts them according to size. The two tallest are told off, each to head a watch, then the next two and so on to the shortest, who brings up the rears of the two companies. After that each waiter has his number and always takes the same place in the ranks at the muster before and after each meal. In hotels where there are many waiters they wear their number either on a metal badge or ribbon, one intention of this is to enable a guest to identify any waiter he may have to make complaint of.

The captains of the watches are not chosen for their stature, but for their superior ability and reliability, their habitual punctuality and steady conduct. They receive one or two dollars per month more than the rank and file and get the best tables to wait on. They take their places at the head of the squad when marching to or from the dining room, except in the case of there being a second headwaiter, when he heads one of the watches and the captain marches in his numbered place in the ranks.

There are other waiters under the headwaiter's control who do not come into these dining room watches; they are in the officers' dining rooms, nurses' and children's ordinaries, etc. They generally are required to wear the same uniform and are inspected and governed by the second headwaiter or, in the largest hotels, by the superintendent of the particular department. In the dining room, if there be fifty tables in use, there will be about that many waiters in line in the two watches. As the business contracts some of the tables will be unused and the waiters are dismissed. In the greater number of hotels the waiters are from twenty to thirty—ten to fifteen in a watch.

#### WATCH ON—WATCH OFF.

Both watches of waiters wait on the tables every day, but only one watch does the side work, the cleaning, dusting and preparation, the late, last minute waiting; the extra waiting on late arrivals—that is, those on watch are never free all day, but are within call, ready for anything that may occur unusual besides their regular duties, while the others are free between meals, only being required to report in time for their own meals and for inspection. In fact, however, when the hotel is doing a business anywhere near its full capacity the intervals between meals are very short, and the freedom does not amount to more than is necessary for the waiters to attend to their clothing and keep up their respectable and cleanly appearance.

The watch that is "on" to-day will be "off" to-morrow. The object of having captains is to have some one to get the waiters all together. The trifle of authority and extra pay bestowed upon the captains makes them zealous and watchful of the others. Common waiters are dilatory and unpunctual; they may be fined in some places for punishment for being late, but that is poor satisfaction for the head of the dining room when he wants to see every man in his place, and it is better to have a captain interested in hurrying them up.

The watch that is off to-day has to come early to breakfast. Almost every headwaiter claims the privilege of saying when and how his watches of waiters shall eat their meals, and, besides that, there is so much difference in hotels and their meal times that no rule will hold good for any large number of houses; yet, for example, let us say the "off" watch must be at table to breakfast by six. The "on" watch does not eat until two hours later, but goes to the dining room and there dividing themselves to the different tasks; they dust the chairs, etc., get out the silver and place it; place the bills of fare around, bring in water and bowls of broken ice. The butter, cream and fruit are already prepared for them in the pantry. Fifteen minutes be-

fore the time for opening the doors the other watch of waiters must be ready in the hall. The headwaiter makes his appearance and the waiters in sight join those in the hall outside. At the tap of a bell both watches march in in separate squads; one turns to the right, the other to the left, they march down between the tables and around and form a line, still in separate squads, in front of the headwaiter for his inspections. He then calls the roll and marks who are absent, then notices whether they all have their white cravats on, whether their jackets are whole and well brushed, whether their shoes are free from mud, and then if he has anything to say to them he says it. Next, at the tap of his small silver bell the waiters again face right or left, march between the tables, and each one stops at his own station. Then the dining room doors are thrown open and the meal begins.

It is the duty of the captains, while waiting on their own tables, still to keep a side look out and report breakages, the beginning of quarrels and the breaking of various minor rules and report them, placing the blame upon the real offenders.

Supposing the dining room doors close at half past nine, then half an hour before that time, or as near that as the circumstances will permit, the off watch takes charge of all the tables; the captain of the "on" watch passes along and gathers his men and they march in regular order, but quietly, by the outside tables and out to breakfast. Half an hour later they return in the same manner, and a few minutes after, or as soon as the dining room is clear of guests, except perhaps two or three whose waiter remains at his post, the headwaiter taps his bell and both watches march up to the line occupied before breakfast. After a few remarks the chief gives another bell tap and the boys file out of the dining room, going through the regular motions between tables as before; the "off" watch goes off until the next meal; the "on" watch at the sign with the napkin of the captain disbands at the door, peels off

jackets and goes about cleaning (and thrice a week scrubbing) the dining room and doing the other side work.

#### LET THE HEADWAITERS TELL IT.

There are some things about the headwaiter's position which only the headwaiters themselves can properly depict, and any one who may be in training for such a responsible situation may find some pertinent hints in the following:

"Keeping seats for regular boarders in a hotel dining-room is one of the unpleasant features attached to a head waiter's business. There are some persons who insist on sitting in one place and who won't sit anywhere else. To keep an eye on these particular boarder's seats and see that no outsiders slip into them keeps a fellow hustling. If some one does happen to get into one of these coveted seats and the person who claims it as his own comes in and finds it occupied, there is sure to be a row, and the poor waiter always gets the worst of it. I don't blame a person for wanting to occupy the same seat, but there are times when it is impossible to keep it vacant. For instance, if a party of six or seven come in they have to be seated at one table. At this same table there may be, perhaps, four or five regular boarders' seats, and when the latter come in I have to put them somewhere else. Then they get mad, of course, kick to the proprietor about the "shiftless and unsystematic manner" in which the dining-room is run, and finally the waiter hears from the office. Sometimes, also a person will slip into the dining-room unnoticed by the waiter, and will drop into a seat nearest him. Once seated it is rather embarrassing to ask him to remove, although you know that he is occupying a seat of some regular boarder who is liable to drop in at any moment. I have known persons to come into a dining-room and finding their seats occupied, go out again and not come back until it was vacant. I also knew of a case in which a man left the hotel at which he was boarding because on two successive occasions, he had entered

the dining-room and found his seat occupied. Women are more particular about their seats than the men. They always want to sit where every one in the dining-room can see them, especially pretty women, or young women that are well dressed. No, a head waiter's life is not a happy one. He stands very little show in getting tipped like the regular waiters, because he cannot be of so much service to the person who wants extra attention in the shape of tender steaks, etc., and who wants to be waited on in apple pie order."

#### ANOTHER HEAD-WAITER TALKS.

"Perhaps you think me wholly ornamental—  
A sort of figure-head to carry style;  
That for use I am not worth a continental—  
That I'm only here to wave and scrape and smile.

"When you come to run a force of fifty waiters,  
Fourteen hours out of every twenty-four,  
Rushing 'round with plates of beef steak and per-  
taters,  
Feeding cranks who want the earth — and some-  
thing more.

"You will understand the situation better  
And allow it's quite an act to carry grace,  
With a waiter who's a kicker and a fretter,  
And a boarder snarling thunder in your face.

'Yes, I have to keep the mashers and the ladies  
In respective corners rather far apart;  
For the husbands sometimes take to raising hades  
With your uncle, when the masher plies his art.

"There's the 'reg'lar' from whose little cosy corner  
I must keep the bumptious transient, if I die;  
Else he bridles up and surely is a 'goner'—  
For the place is as the apple of his eye.

"There are times when waiters get a trifle 'nervy,'  
And 'the razors go a flying through the air;'  
This would hint that a head-waiter has to serve a  
Short apprenticeship to Sullivan or Hyer.

"At the mountains I'm engaged in the summer  
season  
And in winter I'm in balmy Flor-id-a;  
That I'm very fond of sunshine is the reason  
For, you see, sir, that's the time for making hay.

"Do we ever take a tip?" sir, you inquire  
Well — that's a curious thing for you to say  
'Do we sometimes shift the waiters round and try a  
Little divvy scheme to help to make it pay?"

"Why! Of course not! We are hardly what you  
deem us  
To such little things we never, never stoop.  
Ah! Indeed, sir! Thank you kindly—*Mr. Remus,*  
*Get the gentleman a varmer plate of soup."*

It is seldom indeed that headwaiters are named in print. There are oceans of print about waiters in general, scoldings, abuse, jokes, sarcasms, complaints and lectures, but the general public and the general run of writers do not know that there are headwaiters, and that they have much to do with the conduct of waiters through their good or bad management. Now, having paid my respects to the headwaiters in so many columns, I shall have something to say concerning waiters at home and abroad, and waiters' tips, and a headwaiter, who wrote to a newspaper shall introduce the subject:

"A headwaiter referring to a recent editorial in this paper writes among other things: 'Waiters are not born, they are just what the headwaiter makes them, good or bad; and what he drills into them whether they become proficient or not. It would be a good idea for headwaiters to adopt Mr. Whitehead's plan and that is, when they take charge of a room they are held responsible for the efficiency of the service, to have it understood that they must hire all of their help, no matter how small the number; if you don't you are liable to make a failure of it. Make it a rule to be particular of the kind of help you hire, and don't take a man who has the name of not staying more than two weeks in one place; the saying, and it is a true one, 'good waiters always tog up,' makes it easy to know them. Do not be arbitrary with your men and pay them off on the slightest pretence. Give a good man a chance, and don't have the reputation that a good waiter can't stay with you, and that you dog them around to much. Treat your men courteously on the street when you meet them, but don't be one of the crowd on the outside, as that is just what gets away with you in the room."

#### WHAT THE DINING ROOM CHIEF TALKS ABOUT.

It has been mentioned incidentally that the headwaiter has something to say to his men when they are drawn up in a line

before him. This is the custom not universally followed. Some headwaiters have little or nothing to say, call it "old-fashioned" "don't believe in it" and so on. Others have "the gift of the gab," and love to talk even too well. It seems very sensible, however, for a chief having such a good opportunity before him to remember the faults of service he may have seen or heard of on the previous day, and reprove and caution his waiters accordingly. The following does not purport to be the straight continuous talk of the speaker, but is a selection of pithy remarks:

"Mr. GEO. F. BETTS, headwaiter at Young's Hotel, Boston, gives his men a lecture on their duties every Monday morning. These are among the best things he said at a recent lecture: 'The first requirement of a waiter is a gentlemanly bearing. No one but a gentleman can be a good waiter. I want to speak now about this habit of passing around subscription papers among the guests in aid of the sick employé. You must stop that. Never beg from anyone but yourselves. Now, in this matter of serving wines, if you don't happen to know what glass to use for a particular wine ask some one. I will gladly tell you. The trouble is that some men can't be told anything, They'll never learn to be waiters. Now, if a person orders a pot of coffee, don't bring up cold milk unless it is called for. Bring up hot milk with coffee and cold milk with tea. Always serve pulverized sugar with tomatoes, lettuce and cracked ice with cucumbers, tomatoes, watermelon, cantelope, and muskmelon. Berries of course need milk or cream and pulverized sugar. A dessert knife and fork and powdered sugar should go with all pastries, while a small piece of American cheese is in order with all kinds of pie. Many men never think of such a thing as putting mustard on the table. Some people like it. There are very few who have yet learned that a boiled potato is proper with baked beans. Don't cover the bread plate with a napkin. It looks as if there was dust and dirt around.

This matter of laughing and fooling don't make a waiter. I should stop it. Never chew tobacco and spit on the door mats, and don't gather in groups around the corridors. Sleeping on watches must also be stopped. All cold meats ought to be garnished with parsley, lettuce, or celery. Be careful about leaving your side towels around. Another man comes along with something to wipe, and he don't know whether it has been laying there for twenty seconds or twenty years. It is a good plan not to wipe your face with an apron nor towel, nor be too familiar with the proprietor. I never allow myself even to drink a glass of lemonade with him. Do your drinking in the proper place. If you don't study these little things you'll always be down, as sure as you're born. Always remember that I'm the boss, too. I'm hired to be headwaiter, and I mean to act it out. If I refuse to excuse any man for the day don't make the mistake of going to the Captain, because I'm ahead of the Captain. Never open a boiled egg for a customer unless ordered. If you see that a guest of the house wishes to be waited on by a particular man with whom he is acquainted, always give way politely and without confusion. A waiter should always keep his eyes cast toward the door instead of out of the window. Be careful in serving any kind of 'fizz' wines to pour them out carefully. In serving old wines never wipe off the dust from the bottle. Never wipe off the label, and be sure to show the label to the gentleman, in order that there may be no mistake. You are all supposed to wear dark pants, with white apron and necktie. No colored shirts are allowed. Your boots must be blacked from this day out. You are excused."

Another chief indicates his ideas of a talk in training waiters as follows:

"What constitutes a good waiter? A good disposition; a thorough knowledge of his duties, with the quality of being polite, attentive and obliging at all times and under all circumstances; a correct idea as to courting and serving dinner parties, in-

cluding the different wines which go with each course. Neatness and cleanliness are indeed necessary passports, and argue strongly in a waiter's favor when applying for a position. Waiters are often judged, or as the expression goes, 'sized up,' by their personal appearance, thus 'the apparel oft bespeaks the man,' and nine times out of ten secures him a position. First-class waiters take great pride in their toilet; spotless linens are pre-eminently one of the first requisites. Hair nicely combed, cravat neatly tied and adjusted, shoes brightly polished (shoes without heels; I am opposed to slippers), and clean aprons and clean towels; also short and clean fingernails; supposing jackets and trousers to be black or of a dark color, corresponding one with the other, and no rents in them, a waiter is presentable and qualified, so far as his uniform is concerned, for service. Nothing worries and frets the headwaiter more than to see a waiter come sneaking into the dining room five or ten minutes after the doors are open. A good 'time-maker' is a prize to the headwaiter. Every waiter in all well-regulated dining rooms, should be at his station ten minutes before the door opens, and inspect his table, see if everything is in its place, properly arranged and perfectly clean. A good waiter is always pleasant, agreeable and affable; always strives to please, and spares no pains in his efforts to give entire satisfaction. A good waiter will never contradict or hold a dispute with a guest, notwithstanding he may be right and the guest wrong. Whether he has made an error or not, he will invariably 'plead guilty to the charge,' and exonerate or excuse himself in such a manner as will be pleasing and not offensive.

"The most important feature in waiting is to serve an order according to order—no more, no less. If a guest orders for breakfast fried potatoes, breakfast bacon, soft-boiled eggs, coffee and rolls, just that number of dishes should be served and no more, and no first-class waiter claiming to understand his business will bring one

dish over. A good and intelligent waiter keeps himself posted as to the contents of the bill of fare, so as to readily give the name or explanation of any dish thereon, if necessary. A good memory is highly essential in the make-up of a good waiter, and none can properly be classed as such with a defective memory. There is nothing more provoking to a guest than to order poached eggs and be served with soft-boiled eggs, or to order roast beef and be served with mutton, or to ask for coffee and get tea.

"A good and conscientious waiter will not try to bring in the entire kitchen for the purpose of extracting the paltry sum of twenty-five cents from a guest. A first-class, painstaking and duty-bound waiter can and will accomplish this without resorting to such methods of extravagance, which are so detrimental to both his and his employer's interests. He is polite, attentive and obliging; courteous, accommodating and patient; fast, prompt and clean, when serving a party. These are the qualities that enhance his chances for obtaining a fee, and when he obtains it under these circumstances he has the satisfaction of knowing he obtained it solely on his merits as a first-class waiter."

#### WAITERS' DRILL FOR A BANQUET.

Perhaps there is no need of argument to show the advantage of such a moderate amount of daily drilling, as has been described but a few pages back. It has the same use for a body of waiters that it has for a body of police or firemen; it keeps them compact, makes them regular in habits, makes them manageable, gives the head man a grip upon them. It would be useful were it only for the muster and roll call to let him know they are all there. It is very easy to "run such a thing in the ground," as the saying is, and as nothing ever escapes the funny men of the newspapers we have here an amusingly exaggerated sketch from an English banquetting place:

"There was nothing of an extraordinary

character about the dinner itself, but quite unusual pains were taken to drill the army of waiters engaged thereat into a proper knowledge of their respective duties. The following unique and novel handbill, presumably distributed to them by some grim, scar-disfigured, veteran half-pay sergeant, was handed to each of the knights of the napkin prior to his undertaking the onerous and responsible duties of waiting upon the Gas Institute:

REGULATIONS FOR GAS INSTITUTE  
DINNER.

Waiters will be divided into two classes, namely,  
*Entree Men* and *Vegetable Men*.

ENTREE MEN will be distinguished by wearing a red ribbon in their left button holes, and Vegetable Men by a white ribbon.

WINE STEWARDS will wear a blue and orange rosette on the top of their left shoulder. All wine to be paid for when fetched; money advanced for this purpose at the hotel office.

SUPERINTENDENTS will wear white waistcoats, and control their tables; when quite ready for a course, they will signify it by holding up their right hands.

TABLES are divided into separate divisions; each table is numbered alphabetically (A B C), and will have a special staff appointed under the charge of a superintendent. Waiters are requested to pay special attention to his orders.

ROLL CALL in the vestibule at 1.30, when each man must be present to answer to his name, he will then be shown his position at table, and receive his badge, after which he will at once take his position until reviewed. All waiters to be in their places at 3 p.m., to assist the guests to their seats.

DINNER SERVICE regulated by the sound of the gong. At the first sound waiters at once stand to attention; at the second sound to proceed to their respective serving tables and commence the course.

SOUP.—At the second sound of the gong *all* waiters will advance to their serving tables and serve soup.

All waiters change plates.

FISH.—At the second sound of the gong proceed as above; vegetable men must then leave the room and secure their vegetables. Each man will have a dish of peas, beans and potatoes. Entree men clear away dirty plates.

JOINTS.—Entree men only serve joints; vegetable men to serve only vegetables and bread.

SWEETS.—Hot pudding and sweets served together, from the serving tables, by all waiters. All change plates.

CHEESE.—Entree men serve cheese and biscuits, and vegetable men lettuce and butter.

N. B.—Immediately after dessert plates are passed round, and all dirty plates and silver removed, all waiters (except wine stewards) are to leave the room and attend to their respective duties, arranged by the headwaiter.

SERVICE PORTERS to bring in plates, meats, soups, etc., and to clear their respective serving tables after each course. During service of fish and joints, one porter to remain at each carving table to serve gravy, etc."

"A Liverpool journal of the semi-satirical order, called the *Porcupine*, has the following amusing commentary on these singular regulations:

"The military spirit having been thus introduced into attendance upon public banquets, we do not see why it should not be considerably developed. It would certainly add immensely to the excitement of the dinner table, and remove in a great measure the ennui and monotony so often experienced when waiting for the various courses, if a stalwart drill-instructor in full regimentals and ablaze with military decorations, were to stand in a conspicuous place, sound the assembly and, in stentorian accents, put the waiters through their facings something after the following style:

"Hawn—tree wait—er-r-rs! at—tintion!  
Vege—tarble wait—er-r-rs! heyes fa—runt!

"Shoul—der-r-r—nap—kins!

"Vege—tarble wait-er-r-rs! present ar-rums— for the soup and fall in!

"Hawn-tree waiters! Standateas!— with the ladle!

"Vege—tarble wait—er-r-rs! For—rum squa-a-re! Char-r-r-ge— with the new perta—ties!

"Hawn—tree wait—er-r-rs! for rum fourdeepin-echelons! Left har-raf fa-a-a-ce! —for the biled mutton!

"Vege—tarble wait—er-r-rs! Slop ar-rums! Doub—bl-bl-ble— for the sparrer-grass!

"Hawn—tree wait—er-r-rs! By yourri-i-ght quick mar—rarch— for the goose-berry tarts!

"Wait—er-r-rs! At—tintion! Gur-r-round—dessert plates!

"By your cen—trrrr-re left wheeeel—to the kitchen!

"'God save the Queen' on the gong."

When we are done laughing with the newspaper, and at it, we may turn back and find a most excellent example in the said handbill, even if it be on a somewhat exaggerated scale. For service is all-important to the success of a banquet. The waiters gathered together for such an occasion are likely to be a mixed lot and many of them as green as they can be, and some such resolute measures for making them know exactly what to do and when are quite necessary to avert confusion and failure. A number of examples of catering on a grand scale have been given in previous pages and not one of them mentions the very important particular, how the waiters were made to understand each one his particular duties on the occasion, and the "regulations" above exhibited convey a very perspicacious guide for all such emergencies. The same paper says: "The waiters at Young's Hotel, Boston, have been 'uniformed' in spotless white, and must cut rather a queer figure. The 'captains' and headwaiters are, it appears, arrayed in dress coats of white flannel."

#### WHO ARE THE BEST WAITERS?

The question is often asked, but only for amusement or to gratify some prejudice by a specious answer. It must be a very unsatisfactory sort of generalization to say that waiters of this nationality or that are the best, or one race or another. Whenever there is one most excellent waiter of any particular nationality, another one can be found to match him of some other race or people. It is not race so much as training. One of the very best waiters I have ever known was a Mexican, but I shall not say the Mexicans are the best waiters on that account. This one had been trained as a valet to a traveling nobleman, had been half around the world and spoke several languages; that is how he came to be such a good waiter when he had to take up restaurant work.

Waiters are a good deal as the various headwaiters they work under make them. Left alone, waiters in general are like boys in school without a master. They take small liberties and seek their own pleasures and interests, and if that is allowed they take greater liberties; they run away with the house. Waiters have to be restrained, they have to feel authority over them. Most of them then are so docile and well behaved the authority has scarcely ever to be exerted, they do right without compulsion. But in every crowd there are bad boys. Some of the bad waiters will stop when they meet in the hall with somebody's breakfast or dinner on their trays and throw dice for the drinks on the floor, until they hear the steps of the next one coming, and then, for fear it may be somebody in authority, they continue their journey to the dining room. Such as these are dropped out as fast as they are found out; so are they that drink and use foul language; those who fail to come up to the other requirements of good waiters, also the weak and sickly ones who are not to be relied upon, and in that way it comes there is a dining room full of picked waiters, and whatever nation or race they may be it seems as if they must be the best in the world, because there cannot be any better. But the headwaiter who sees sights is he that has to gather up all these culls and castaways to open a resort hotel with, all the good waiters being already engaged.

There is another way to answer the question, who are the best waiters? that seems to be not often thought of. The best waiters for this country are they that know the least about the compulsory *pourboire* or tip system of European countries, which has grown to be one of the greatest abuses of the day, a galling tyranny that cannot be shaken off. A newspaper was not long ago started in France with no other object but to try to put down the compulsory tip system; it was called the *Anti-Pourboire*, and the waiters turned out several thousand strong and put it down, prevented its being sold, mobbed the carriers, mobbed the



newsstands that took it for sale and extinguished the paper.

On the other hand, some four or five years ago the waiters of New York organized for a purpose quite opposite the Parisian waiters'; they organized to fight the tip system—the waiters themselves on this side wanted to do away with tips! How was that?

That move was taken because there are more than the waiters concerned in the abuse of tips. It has got to such a pitch in France, England and all over Europe that the waiters get no pay in some places, but have to work for the tips they will extract from the customers; in some places where the chances are poor they get small wages; but in others where the chances are good, where the customers are mostly wealthy people, where a good many American tourists stop and throw money around loosely—in such places the waiters not only work for nothing, so far as wages are concerned, but they even pay for the privilege of working; give the proprietor thirty per cent. of the tips they receive and contribute another portion to pay for the breakage that takes place in the establishment. There are a good many places in New York where waiters are employed, whose proprietors are of the same class with the same ideas as the restaurant, café and hotel keepers over the water and they wanted to do the same ways; wanted the waiters to work without wages and live on their tips; but the waiters liked the old way best and struck against the attempt to change it. That is why they were in favor of putting down tipping. Of course, they all knew that tipping would go on as it always does in this country, in a free-will manner; they struck against making it compulsory for a guest to give them something or else be ill-served, asked for a fee and made to feel small and uncomfortable by them.

#### WAITERS' WAGES AND TIPS.

Those New York waiters, no matter what race or nation they were of, "knew

which side their bread was buttered on," as the old saying is, for while tipping goes on quite liberally in this country if it is left to the givers; that is, if Americans are let alone and allowed to give tips as favors to those they like and want to reward, they would hardly yield so much if the waiters were compelled to take on the eager, hungry, anxious look, and had to touch their caps and hold out their hands in order to make wages out of their jobs, because that is not the way of this country, and would make the tip seem like a debt to be paid instead of a favor bestowed, and it would not be very generally submitted to. A little way back there is a quoted paragraph concerning a number of waiters going to the large hotels in Florida, and the same paper says further down: "The salaries for waiters are to be \$25 per month, with an addition of \$4 on the basis of the premium system. They will probably leave the North in a special car in November."

We all know about how wages run, but it is well enough to let somebody else say it, too. That is first-class wages paid for first-class waiters. The common rate for summer resort waiters averages \$18 per month; that is, the range is from \$15 to \$20. In the generality of hotels between seasons or for all-the-year jobs, waiters are hired as low as \$12 per month, or from that to \$15. In any of these places the waiter *hopes* he will make something besides, every waiter expects to make something, yet it is very uncommon for the one who engages them to talk about tips as a part of the bargain, or to make a business of the tip question. Of course, this does not refer to restaurants in the eastern cities which have foreign proprietors and waiters following their own ways, but to the generality of hotels and restaurants all over the states. The probable tips may be thought about, but there is no sort of promise made to the waiter that he will get any, and no advantage to the proprietor if he does. And still the tips secured by good and lucky waiters amount to something

considerable. Here is a waiter at work who is sure of a steady tip every week:

#### CHERUBS AT THE HOTELS.

There is something uncanny about these mature children of the town. I was at the Windsor Hotel at dinner with some friends a short time ago when a pompous little woman strode down the long dining room, followed by two little girls, hand in hand. Neither of them was more than 9 years old. They settled themselves in their chairs, folded their skinny little hands, and then proceeded to stare about them and comment upon their fellow-diners. The elder of the two children, after looking intently at a maiden lady of rather noticeable attire at an adjoining table, turned to her mother and said composedly:

"What a really startling old frump that is, mamma?"

"Which one, dear?" asked the strict disciplinarian of a mother.

"That cheerful guy beside the bald-headed man over there."

"Oh, yes," said the mother, with a well-bred smile, "I've seen her before. But don't be so slangy, Marion. Have more tone. Order your dinner now and see that you let purée and lamb alone. It's too rich for you." Then to the waiter: "Take her order, Auguste."

The waiter leaned obsequiously over the child, who was studying the menu with a frown on her little face.

"No soup, Ogeest," she said intently, "but a bit of weakfish with egg sauce, an' a kidney omelette—not flat, you know, but nice and puffy—and artichokes——"

"Ver' sorry, Mees Maryon, but there is no arti——"

"There, I thought so," said the girl, slamming the card down on the table and biting her thin lips. "It's the most provoking thing! Whenever I set my heart ——"

"We have some green corn——"

"Eat it yourself!" said the child in a huff.

The waiter was quite unmoved. He seemed to be accustomed to such ebullitions of temper and went on suavely taking the orders of the others, while Miss Marion sat the picture of overdressed, pampered and pouting discontent.

Now, whoever wrote that piece for the newspaper was thinking about the poor little children, wanting to train them for their mother, but we will just take notice of "Ogeest." He has got as good a thing as he wants for one table and never gives a second thought to the behavior of anybody. He will get what that family wants if he has to beg for it in the kitchen, coax for it, buy it, steal it; and every Sunday or Monday morning he finds "Mees Maryon's" little hand held out to him with a five dollar bill, probably, or two or three silver dollars, at least, and when the family goes away there will be a parting fee of larger amount. If "Ogeest" is fortunate enough to have four such parties to wait on and get his American plan wages besides, he is certainly doing very well. And he doesn't care whether the children are well-trained or not. But some young men are so constituted that they cannot take such "sass" without resenting it in some way. Perhaps they have not been raised right. Anyway they are not adapted to be waiters.

Contrast the fat condition of the waiters thus far mentioned with those of the Edinburgh, Scotland, International Exhibition, a couple of years ago: The waiters engaged to pay the refreshment contractor ten shillings (\$2.50) a week each for the privilege of working for him without wages, and then he printed in his bill of fare that the prices there set down *included attendance*, which meant nothing for the waiters. Here it is as it appeared in a newspaper, but without the long bill of fare, which is unnecessary:

ROUGH ON THE WAITERS.—The head-waiter at one of the Edinburgh hotels sends us a rather indignant protest against the terms on which his brethren are engaged at the Exhibition now open in the Modern

Athens. He points out that the conditions under which the waiters work leave them but one alternative if they are to make a living at all, and that is to overcharge the public. The refreshment contractor, it appears, receives a weekly payment from each waiter, and yet makes attendance an inclusive charge in his catering tariff. Unless liberally tipped they are likely to be losers, and their chances of pocketing fees are to a great extent extinguished by the intimation that attendance is included in the bill. Scotchmen, who of course constitute the great majority of visitors to the Exhibition, will probably find this intimation very comforting, and will scarcely see the force of paying twice for services rendered. We subjoin the form of agreement subscribed to by the waiters:

[Copy.]

"I, . . . . ., hereby engage myself as waiter to you at the International Exhibition of Industry, Science and Art, Edinburgh, 1886, and to pay to you, for the privilege of serving you, ten shillings per week, at the end of each week. I will receive my food at the Exhibition on every lawful day, when open, but I will provide and pay for my own lodgings, and for my food on Sundays. I will make good any breakages in my department, also any cutlery or plate that may be lost or damaged, and will be entitled in my own name to recover from customers any breakages which they may be responsible for. All sums recovered for breakages shall be specially set apart in a box to be provided therefore, and paid over to you when required. I will be liable to dismissal on a moment's notice, without reason assigned or compensation given, and I will be entitled to leave on a days notice, having first accounted to you for breakages and any moneys that may be due by me.—Witness my hand this . . . . day of . . . . ."

That is the condition of affairs which the New York waiters banded together to keep out of this country; but the Parisian waiters fought to uphold it, for the simple reason that there was no hope for them to get

wages, and if the tips which they depend on were abolished they would starve. So we will say again, the best waiters for this country are those who have the least of the old-country tip system in them.

#### LONDON WAITERS.

The waiters over there have a good way of not despising small tips. Little sums and a good many of them are what counts up big at last. The way it is here one person will give perhaps half a dollar, then a dozen others will go out without giving anything because they cannot afford to give a half and they are ashamed to offer less, they think perhaps the waiter will insult them if they offer small change, so they don't give anything. A London waiter tells his experience, which shows that even pennies count up in a week. He was a "greeny" in some respects, though he had a good idea about waiting. He got into a small restaurant where there were only two waiters, himself and another. He went for sixty cents a week wages and "what he could pick up" and his dinner. Sixty cents a week is so near nothing it would seem like a mistake was made in telling it, if we did not know that many of them go to work for no wages at all and pay the proprietor besides. Even in this cheap restaurant it was the custom for each person that ate dinner or lunch to pay the waiter two cents "for service," and some paid three cents. They were not really obliged to pay it, but it is the custom of the country and most of them did in this restaurant. The green fellow soon found out that his partner was playing sharp on him, letting this one do the waiting and he went around and collected the pay and kept all the tips. After they had had a fight over that they agreed to divide the dining room, one took one side, one the other. It appears they served about 100 dinners a day, besides the other meals and lunches, that was 50 customers apiece, and if each one gave the waiter an English penny, which is two cents, that made them a dollar a day apiece, or seven dollars a week. And the

one telling it says they did do as well as that, for when he got his rights and his partner could not cheat him, he says his pay amounted to twenty-five English shillings a week, which is over six dollars. That is not much wages, but it shows how small tips make a considerable sum in a week; they make more than the odd quarters and halves do that only come from a few.

American tourists generally are ashamed to give small tips, this is the way they do:

"The American tourists who invade England every summer are in the habit of carrying back a grievance which is largely of their own creation. At every turn one meets them complaining that 'in England one has to give so much money to all the servants — it's perfectly dreadful,' while they themselves are the only people who ever do anything of the kind. The well-traveled London correspondent of the *Chicago Tribune* makes the following remarks on the pretentious liberality of his countrymen, which hotel-keepers who are brought so intimately in contact with them will read without surprise:

"I have known an American lady who gave the man who tended the hotel lift half a crown daily and half a sovereign weekly. I knew a vulgar old American who gave gold to every servant on all occasions. And then, after making fools of themselves in that way, they go home and report that the Prince of Wales and the Archbishop of Canterbury are the only two men in England who will not take a tip. I have heard of an American who, when on the steamboat at Liverpool about to return to America, thus addressed the assembled crowd: 'Gentlemen, if there is one of you to whom I have not given a shilling I wish that he would hold up his hand.' But it was very silly of him. I have lived eleven years in England, I know both English and American society fairly well, and I can assure the untraveled Yankee that he need not give away a sixpence in the year more in one country than in the other. It is only where the

raw, green Americans have been that the servants are spoiled in this respect and made grasping and overfamiliar."

But Americans are not the only ones.

"The following clipping is from the journal known as *Men and Women*: 'The business of a waiter at the Star and Garter, at Richmond, must be a somewhat profitable occupation if there are many guests like Mr. Henry Irving, who, on the frequent occasions on which he dines there, tips the waiter with a sovereign. This came out at the Wandsworth County Court a few days ago, when one of the waiters at that famous hostelry sued a brother of the napkin for refusing to go halves with him in the magnificent 'tip' bestowed by Mephistopheles."

It was in London that ten thousand waiters replied to one advertisement which shows that there are all classes and styles of waiters there, and tens of thousands that learn waiting as a trade and follow it up all their lives.

Some way back may be found descriptions of the ways of checking and paying in various places, but the London restaurant system has not yet been mentioned, it is this:

#### THE LONDON CHECK SYSTEM.

"When a waiter enters the service of the principal London restrarateurs he has to bring with him ten dollars for 'working money,' as it is called. He pays this in to the cashier and gets ten dollars worth of meal checks for it. Whatever is ordered he pays for at the kitchen with checks. He is provided with a blank tablet which has manifold or copying paper between the leaves, and thus writing the bills in duplicate, he tears one out and gives it to the customer, and receives the customers money, and the copy remains in the book.

When business is over for the day, the waiter takes his book containing the duplicate bills to the office, together with whatever remaining checks he has; the totals of the different bills are then added up, and the grand total must correspond with the amount of checks used by him during the

day. Should the total be more than the checks, the inference is that he has overcharged somebody, and he must immediately refund, whatever the amount is, to the firm or leave. He, of course, generally chooses the former alternative. If, on the other hand, the total should be anything less, he has the satisfaction of knowing that he has lost it, and supposing either that somebody has gone without paying their bill when his back has been turned, that he has given too much in change, or that, in the rush of business he has given a three-shilling check for a threepenny, which, seeing they are marked pretty much alike, is not improbable. Three shillings and sixpence (nearly \$1.00) per week is charged each man for glass breakage, and the firm I speak of pay no salary to waiters; indeed, few restaurateurs do, and where they do it is but a mere pittance. What a waiter mainly depends on for his living is his tips. His makings, assuming that he works fifteen hours, average as a rule from five to seven shillings per day (\$1.25 to \$1.75) and considering the great disadvantages under which he labors, and remembering that he has to bear a smiling front through it all, this is not after all such a fabulous sum. Of course it is only right, and proper too, that a large firm like the one I have spoken of should have such strict rules; but I have shown that the waiter's lot, any more than the policeman's is not always a happy one.

#### THE "TWO BY FOUR."

By the return call of the electrical system, with tiny bells, the guest can telegraph all ordinary orders to the kitchen and receive answers both of the sonorous and the solid sort with the speed of lightning.

It is a mistake, however, to suppose that there is anything in this more like magic than the practice of the most expert of human waiters at the great resorts, where waiters as well as guests are counted by the hundreds, and therefore cannot be individually known nor very perfectly watched.

It is doubtful if the new automatic waiter will ever come up to the sleight-of-hand proficiency of the human waiters who do such neat tricks as that which they call the two-by-four, by which they sell the employer's goods for him and returning perhaps the cost price, putting all the profit in their own pockets, and make the employer think that he has been watching them at the same time, exactly as a sleight-of-hand performer does upon the stage; and this is only one of the many tricks which the automatic waiter can never do. In a large restaurant the waiters must buy with their own money the dishes ordered at their tables, paying for them at the cashier's desk, half way between the dining-room and the kitchen. Spring chickens are charged at seventy-five cents for single orders, but two orders are \$1.25 and four orders at once are \$2.50. The waiter goes to the kitchen with four dishes and orders four chickens, gets them, and starts for the cashier's desk, but when he arrives there he has only two chickens; he shows them, pays for two, and starts for the dining-room. When he gets there he has four chickens, as he had when he left the kitchen. He sells them and clears \$1.25 by the operation. Like all those conjuring tricks it is easy enough when one knows how it is done. In the first passage the waiter sticks a chicken in each breast of his jacket and turns the empty dishes upside down on the remaining two on his tray, "to keep them warm, because his customer ordered them so," and in that style appears at the cashier's desk. In the next passage he replaces all as they were before.

#### AMERICAN HOTEL CHECK SYSTEM.

A novel check on both visitor and waiter is in use at one of the American hotels. On entering the dining room a boy hands the guest a card, upon which are printed amounts up to about \$2.00. On one corner is the consecutive number stamped upon it by an automatic numbering machine. When the visitor gives his order, this ticket is taken away by the waiter, and

when the latter receives his order at the kitchen the card is returned to him with the amount punched out. If anything extra is ordered, another sum, representing the aggregate of the two orders, is punched out, and the customer pays the total sum punched at the desk. The consecutive numbering denotes the day of issue.

#### PARIS WAITERS.

There was another thing the Paris waiters went out on strike about besides the *Anti-Pourboire* newspaper. It appears that they all go to employment offices when they are out of work and have to pay to register and pay for a job when they get it. They found out that hundreds of small employers, stewards and headwaiters were going shares in these fees, and would discharge their waiters frequently without cause, only to make a profit out of the fees the new waiters would have to pay to get the jobs. They struck against working in any of these houses or letting others go in. When that trouble was settled they formed waiters' associations, where employers could apply when they wanted help, and paid no more fees to employment agents. While they were out on strike indeed they made the abolition of the employment offices one of their demands, and, like the New York waiters, they wanted the establishment of regular wages for waiters, and not have to depend on what they could "pick up." They complained that besides not being paid any wages they were only allowed to keep one-third of the tips given them, the proprietor getting one-third direct and another third was taken from them to pay breakages; no matter who did the breaking the tip money had to pay for it. This system is too deep rooted, however, and the waiters did not succeed in breaking it up. It began long time ago in the palmy days of the Palais Royal gardens when the crush was so great that waiters made perfect fortunes, and in consequence the proprietors, turning this to advantage, sold the waiters jobs at from \$400 to \$1,000 per year, and still the wait-

ers realized splendid competencies. But that time is past. Such times occur at some of our pleasure resorts, when the waiters find greenbacks plenty for a short time, but it only lasts a few weeks.

#### DISCIPLINE IN PARIS RESTAURANTS.

"The discipline of the waiters at the Café de la Paix is very strict. Every waiter has to be at roll-call at 7.30 a. m. under pain of 10d. fine for every five minutes he is late. Boots may not be worn by any waiter in the establishment. It is forbidden under pain of dismissal or a heavy fine to give change to a customer in instalments. The *maître d'hôtel* has the right to satisfy himself by calling at the residence of a waiter who may claim dispensation on the plea of sickness, whether the man is really ill or not. Each waiter has to pay \$1.00 on every \$20 worth of drinks he takes, as a percentage on the *pour-boires*. Waiters have a holiday, *jour de sortie*, every fortnight. The tables are allotted according to their business value in order of their seniority. Every new waiter, or any waiter returning to work at this café after absence has to begin at the bottom and gets the worst tables. These are some of the regulations at this café, and that they are good, if strict, is proved by the admirable discipline that obtains there."

#### ACCOMMODATING WAITERS.

"It is a remarkable characteristic of the waiter in Paris restaurants that, no matter what anyone asks for, even if it should be "a fried piece of the moon," those gentleman-like attendants will invariably reply 'Yes,' and either bring it, or, on returning, assert with sorrow 'that unfortunately there is no more left.' A well-known Government official tried this joke recently, when he ordered the waiter to bring him 'a sphinx à la Marengo.' 'But I grieve to say we have no more, monsieur,' replied the waiter. 'What, no more sphinx?' exclaimed the Minister of the Interior, feigning astonishment. The waiter lowered his voice, and murmured in a confidential whis-

per: 'We have some more, monsieur, but the truth is I should not care to give them to you, as they are not quite fresh.'"

"Dr. X. breakfasts every morning at a New York restaurant. One day he observed the waiter limping about painfully.

"Have you got lumbago?" he asked sympathetically, 'or rheumatism?'

"I don't know, sir, but I'll just step into the kitchen and see. I don't think there's a scrap left of either."

#### TRICKY WAITERS.

Waiters who have to work under such disadvantageous conditions as those the Paris waiters struck about are driven to all sorts of schemes to get even. This is one way, as a correspondent tells it:

"It is notorious to all habitués of this dancing-salon, and in the Quartier Latin generally, that the waiters invariably either overcharge, or else return deficient change. I speak from experience, as I generally do. I have been overcharged or have had *deficient change given me, no less than fifteen times*. Sometimes the sum wanting has been a franc, sometimes more, sometimes less; but I have *never once* been served at the Bal Bullier without having to point out some *mistake* when my change was handed me. And as, on purpose to convince myself, I have tried every waiter in the place, and found them all alike, I can come to no other conclusion than that these mistakes are a system. One waiter confessed as much, saying the times were hard, that he had to work all night, and would earn next to nothing legitimately, etc."

Another one says:

'One of the tricks of the waiters in the Parisian resaurants, is in bringing change, to cover over either a gold or silver piece with the copper money. As the customer usually waves away the grosser bullion with a contemptuous gesture, the waiter gets the hidden coin into the bargain. Another trick is to cover over a gold coin with the bill, on the chance that the customer will not lift up the slip of paper.'

But if we begin to look up the tricks of waiters we shall find as many on this side the ocean as the other:

"'If I should discover a system to prevent waiters from robbing guests,' said Paul Bauer recently, 'I would pay well for the information. Proprietors of large summer resorts are all anxious to solve this perplexing problem especially those who pay small salaries.'

"When guests order two or more portions they are seldom served their full order although they pay for it. The writer suggests that Mr. Bauer and others interested auction off their present stock of crockery and order a series of special dishes to be known as Protective Crockery. On platters and vegetable dishes intended for single portions stamp or paint 'one portion' on the sides or rim of the dishes before they are glazed.

"For two or more portions the same system may be followed, but, of course, on platters a size larger. If the notice was on the center of the dish the food would hide it, and it would not be seen until it was too late to correct a mistake.

"Dishonest waiters would, of course, attempt to beat the system by hiding double portion dishes in convenient places. They would also try to bribe the dish washers and others handling the plates. Very bold waiters might attempt to use a dish taken from the dish baskets, but a little watchfulness would easily foil them. These dishes as soon as washed, might be placed under the care of the chefs. They would see that the right portions were placed on the proper dishes, and the check clerks would easily prevent cooks and waiters from standing in with each other.

"City hotels using the half portion system might protect their patrons by adopting this system."

#### BERLIN WAITERS.

"I fancy all the good waiters leave Berlin, and that none but poor ones stay behind. One meets with excellent German waiters in middle-class English houses, and never, as far as my experience goes, in

Berlin. On the other hand, in the first-class hotels and restaurants in Berlin the waiters are models of attentive politeness and intelligence. I think the way it works is this: Smart men intending to adopt the profession of the *serviette*, do an apprenticeship in Berlin, and then start on a grand tour through the capitals of Europe, learning languages and perfecting themselves in the difficult art of serving and satisfying all sorts and conditions of men. When they have acquired these qualifications, they return home and get good places at once in first-class houses. I had a chat on this subject with the headwaiter at the Prince Heinrich Hotel in the Dorotheenstrasse, and he told me he had been to Naples, Rome, London, and Paris. He could speak all these languages perfectly. One thing he told me which I found of interest, and which was that it is nowadays a matter of almost absolute impossibility for a German waiter to get a berth in Paris, and that he left because his French colleagues made his life intolerable for being what they were pleased to call 'un sale Prussien!'

"There seems, it is true, but very little inducement to a good waiter to remain in a Berlin catering house, unless as *Zahlkellner* (cashier who receives all tips and divides them), or at a good hotel, where distinguished foreigners and distinguished tips are the order of the day. I interviewed a waiter at a representative establishment, and he told me his wages came, after all deductions for breakage, washing, etc., to less than \$4 a month, and that his tips never exceeded \$20 a month at the most. He said the food he was supplied with was so bad and scanty (soup at breakfast, a plate of meat and vegetables for dinner, coffee at four, and *Aufschnitt*, or bread laid over with sausage or cheese, for supper), that he had often to buy food outside. All the beer he took from the establishment he had to pay for. Twenty or twenty-five dollars a month, at the outside, including board, seems to be the average lot of the German waiter in Berlin, and a very poor lot it is."

#### A GERMAN BARON AS A WAITER.

"I was dining with a friend at one of the most noted restaurants in London—not a hundred miles from Regent Street. We had a most attentive waiter, whose face seemed very familiar to me, and all through the dinner I was puzzling my brains as to where I had seen the man before. 'Fritz,' I said (all German waiters in London answer to the name of Fritz, and all English ones to that of George), 'your face is very familiar to me; where have I seen you before? Were you at the Criterion?' 'No, sir,' he answered very quietly, 'I met you in Berlin at dinner, when you and Mr. B—dined with Herr Engel.' It flashed across me in a moment who the man was. I said, 'Why, you're the Baron von G——.' 'The same,' he replied, half sadly, half comically, 'the same, minus the mustache.' I shook hands with him, and thought to put both of us more at our ease by adopting the same half-facetious tone with which he had greeted me. So I remarked that I was glad to congratulate him upon the genius which he displayed in his new avocation, for, I added, 'I might have known there was good blood in you, for I was never waited upon better in my life, and I am one of those who believe that no one can do anything better than a gentleman if he really gives his mind to it.' The Baron was flattered, and said that no one who had not dined could properly know how to wait. 'I,' said he, 'have so often noticed and sworn at the shortcomings of waiters that it is a strange thing if I did not know how to wait decently myself.' Every German who is down on his luck can trace the cause of his misfortunes to Bismarck, and my waiter friend was no exception to the rule. He was one of seven sons (all barons, of course). Two had managed to get on tolerably well; one being colonel of a crack Prussian regiment, while the eldest looked after the ancestral acres. My waiter friend had been living on his wits for a good few years, the slender income from that source being eked out by an allowance of 1,000 marks (about £250) from the elder brother.



Finally the income of the landed proprietor became so curtailed on account of Bismarck (how I did not quite understand), that the younger baron's allowance had to be stopped. Now, it is very hard to maintain baronial dignity on £250 per annum; but when it comes to maintaining the said dignity upon nothing at all, the task is beyond even Teutonic shrewdness. So the baron turned waiter, and a brother of his (also a baron, of course) followed his example. Both came to England, as being the less likely to meet those who would recognize them."

#### HOW WAITERS FIGHT DUELS.

"The *Times* correspondent at Vienna states that two waiters found themselves under the necessity of fighting a duel. The seconds seem to have been but little skilled in the use of firearms, for in loading the pistols one of them managed to fire his off, which carried away one of his fingers and wounded the other second in the face. The principals, having thus vicariously had some experience in the use of firearms, found their valor oozing out of their fingers' ends, and expressed themselves perfectly satisfied with this vindication of their honor; they hastened to shake hands and to convey their seconds to the hospital! Bob Acres could not have been more valiant."

#### FEMALE WAITERS.

It is said that the Bouillon-Duval restaurants of Paris employ about 8,000 women, of whom over 5,000 are waiters in the many different establishments belonging to that company. We have seen in a previous page that these women waiters received tips, the two or three-cent tips customary in that country. But the fact that they received about \$12 a month regular wages besides is significant, when the men waiters do not get any wages, for it shows the same there as in the thousands of hotels that employ girl waiters in this country, that women never get as many tips nor as large ones as men. If it were really an

object to abolish tips altogether, it could be done easily by employing girl waiters only. People will not give to girls as they will to boys. Girls do not know how or have not the boldness to extort tips from unwilling customers, or punish those who do not give with neglect and lofty disdain. They do not generally know how to get the hardest and toughest steaks and the oldest and driest biscuits and shoot them down on the table with their faces turned another way, not to see whether the non-tipping offender can reach them or not. Some of the girl waiters get along a good way towards learning these things, but they lack thoroughness at it; they are timid, their dreadful revenges are all small and the culprits laugh at them, when they would not dare to laugh at the boy waiters, and go off without tipping the girls just the same. But the great majority of girl waiters never expect tips and never try to extort them. They have their favorites to whom they show partiality at the table, but it is not often that the prospect of tips is at the bottom of this partiality. Nevertheless girl waiters do in some places make a good deal in the way of tips. They get their regular old bachelors, judges or doctors, permanent boarders, who put down a dollar or two for their waiter by the side of their plate punctually every week, and their harvest is at Christmas, when, if nobody gives the girl waiters tips at other times, there is sure to be a shower of Christmas gifts for them. Occasionally there will be rivalry between two or more favorite girls, each one has her partisans among the boarders; and those at her table after subscribing themselves will gather all they can from others trying to make up the biggest purse for their favorite waitress. At such times the presents run up to fifty, eighty or even a hundred dollars for each one.

Among the recommendations of girl waiters, which causes them to be employed all over the North in the quieter and smaller-sized hotels, one is that they can generally be hired for lower wages than

boys. Another very important one is that they change about less and seldom or never go on strikes, though instances of the girls striking have been recorded where they were persuaded into it by men.

It is a common thing in England for female waiters in hotels to serve high-class dinners, so far as the several courses go, but at the same time a butler attends to the serving of the wines. In this country "Phyllis" never reaches a very high or dignified position as a waiter. But they seek her for places where drilled and uniformed waiters cannot be afforded, because "Phyllis" is neat and cleanly without a uniform. Says one: "Everybody knows the greasy-handed, grimy-cuffed and grimy shirt-fronted individual who pants and 'blows among the chops and steaks,' and everybody as a rule avoids him. Better far a neat-handed 'Phyllis' than a male waiter redolent of mutton fat and insensible to the charms of soap and water."

#### NEW YORK WAITER GIRLS.

"The custom of employing pretty waiter girls in the restaurants in lower New York increases. They bring a certain class of patronage, but the patronage is not a very lucrative one to the proprietors of the restaurant. The men who frequent the respectable restaurants where waiter girls are employed are usually small clerks with small salaries, but high aspirations, who smoke cigarettes and spend all the way from fifteen to twenty cents at their luncheons. To them it is an experience of wild and lurid excitement to be waited upon by pretty girls. They feel that they have done a brash and manly thing and never return from the restaurants to their shops without telling their brother clerks of the 'mash' they have made at the restaurant. In the larger eating houses, where big dishes are served and where it requires activity, considerable endurance and deftness to wait upon customers, girls have been found unsuitable, but in the dairies they quite fill the bill."

*Commercial Traveler* (to waitress): "So, then, you are my waiter, are you? what is your name, is it Mary?"

*Waitress*: "Indeed not—my name is Pearl."

*Commercial Traveler*: "Oh, then I suppose you are the pearl of great price?"

*Waitress*: "No, I am the pearl that was cast before swine."

#### A DINING ROOM JUNO.

A Boston lady who returned from the White Mountains last week told the Historian about an interesting experience that she had when she went there. She was greatly taken on the train going to the mountains with a young woman on the seat in front of her, who was in form, in face, in bearing, a veritable Juno. During the long ride she built many airy castles of imagination around the form of this god-like young person. She tried her on as a society queen, but she looked rather too sweet and unwordly for that. She tried her as a countess traveling in the United States, but she didn't seem exactly foreign. The lady couldn't make anything else of her than a princess—an ideal princess, traveling incognito.

By and by her sojourning place was reached and what was her delight to see the beautiful young woman alight and go to the hotel where she herself stopped.

"Now I shall have an opportunity to know her, perhaps, or find out who she is," said the lady to herself.

That night at dinner the Boston lady seated herself at the table, began peering about among the guests to see if the one who had charmed her so completely on the train was there. Suddenly she heard the voice of the waiter-girl over her shoulder: "Soup, ma'am?"

She looked up at the girl. Heavens and earth! It was her Juno, her princess of the journey from Boston!

## THE PENNSYLVANIA-DUTCH WAITRESS.

"Ter bodatiss iss all."

This remark was made by a rosy-cheeked, black-eyed dining room girl in a most excellent Pennsylvania Dutch inn, in a Lancaster county village. I had just called for another baked potato.

"Is all!" said the dining room girl with a smile and a shake of her head.

"All," said I, "all what?"

"Ter bodatiss iss all," answered the girl, impatiently, and with a suspicion of contempt in her tone, "iss all."

A native, with the whiskers of a patriarch, came to my rescue.

"She means ter haind't no more alretty. Ter all."

And thus I learned that the Pennsylvania Dutch never say anything is "gone." If the bar runs out of beer, the beer is "all." When the sauerkraut barrel is empty, the kraut is "all." But there is one thing that is never "all." That is pie. If some thrifty and hearty Dutch citizen should ever ask for pie, and word should go back to him that there was no pie, the relations between him and his host would at once become strained. But the necessity of asking for pie seldom exists, either at tavern or farm house. At a Pennsylvania Dutch inn the waiter doesn't disturb your tympanum with:

"Mincerapplepierpud'n?"

She fetches in the pie at the proper time and places it before you. Not only pie, but a whole pie; and not only one whole pie, but sometimes three or four whole pies, all of different kinds. The black-eyed girl with rosy cheeks who knocked me out by telling me that the potatoes were "all," placed four uncut pies on the table immediately afterward. There was a cheese custard, a cranberry tart, a sweet potato custard and a snitz pie. No matter how many pies there are on the table every guest is expected to help himself to each one as his inclination and capacity prompt him. There is always enough. The only thing that is short about Pennsylvania Dutch pies is the crust.

## THE MISCHIEF OF PRETTY WAITER GIRLS.

[From the *St. James Gazette*]

Though the soup may be clear and the fish may be good,

And the lamb and the sparrowgrass tender,  
How on earth can a person attend to the food  
That attendants so fair to him tender.

Though each dish be success, and the menu complete,

And the table could not be laid neater,  
Yet I languidly let fall the spoon in the sweet,  
Since my thoughts turn to something far sweeter.

Though the Glessler right up to the brim of the glass.

Like a soufflé of diamonds be creaming,  
It looks dull when I glance at the eyes of the lass.  
That just over my shoulder are gleaming.

No, give me the waiter's thick hands and white tie,  
When I wish to persistently gobble.

For I can't feast my mouth when I'm feasting my eye,

Nor digest when my heart's on the wobble.

## GIRLS ON A STRIKE.

"A rather funny and somewhat unusual strike is reported at a Swampscott (Mass.) summer hotel. Nineteen table girls struck for an advance of 50 cents a week. It seems there was a ball at the house, and after it was over the girls appropriated the ice cream that was left, but the proprietor put in an appearance and took it away from them. The girls resented this and asked for an advance, which was promised them. Fearing that the proprietor would not keep his word, they submitted a paper to him by which he was to bind himself to retain their services until the close of the season. This he refused to do, and went to Boston after breakfast to procure new help before lunch. In his hurry he boarded the wrong train, and before he knew it he was on his way to Salem. Here he set himself right and was soon on his way to his destination, where, after considerable difficulty, he secured enough help, temporary and permanent, to serve the lunch. The matter created no little stir among the guests, who sided with the girls, claiming that the ice cream belonged to the guests, who paid for it, and that the proprietor went too far in the matter."

## ANOTHER STRIKE OF WAITRESSES.

"One important strike up in the Reading coal region I haven't seen anything in the papers about," said Samuel Royer, of Ashland, Pa., "and that was the strike of the hotel kitchen and dining room girls of Ashland. The new men that the Reading Railroad Company are sending in there to take the places of the striking employés, at first went to the different hotels to board. There wasn't a girl working at any of the public houses who did not have a sweetheart among the strikers, and they held a meeting and resolved that they would not cook nor wait on any of the men who came in to take the places of the striking sweethearts. The landlords were notified of the decision, and informed that they must close their hotels against the 'scabs' or get other help. The landlords couldn't see how they could refuse to accommodate the men, and every hotel girl in the place quit work. It was impossible for the landlords to get other help, and the result was that the hotel keepers gave in after one day of the novel strike, and gave the new men notice that they must seek quarters elsewhere. The girls then resumed work. Proceedings were then taken by the railroad company to punish the hotel keepers under the law for refusing to accommodate their men. Then the hotel keepers agreed to take the men in again, but they put up their prices so high the men could not stand it, and went to boarding themselves in the car sheds."

## RESPECT INSTEAD OF MONEY.

Well, but girls rarely strike or even strike back when an unkind remark is levelled at them. And it must be said in partial excuse for their not reaping a fair share of tips that it is largely on account of the respect of man for woman that they suffer in that respect. A good many are afraid to offer them money lest it may insult them. There are some men waiters, as a writer remarks, "who look so much like archbishops, and behave in such a stern and stately manner that the inexperienced

visitor is overawed and would not have the timidity to offer them less than a dollar for a tip." When it is a "Juno" that is so encountered, who goes about her duties with such dignified reserve that she scarcely seems to see anybody even while she is scrupulously attentive, then nobody dares offer her anything at all. It is said some of the White Mountain "school marm" waitresses at the summer hotels do refuse to take tips that are offered to them. The question then arises: What do they do when the customer leaves a half or a dollar under his plate and goes out, and never looks back to see whether Juno picks it up or not? Do the Junos sweep up all such dollars with the crumbs and throw them out of the window?

## COLORED WAITERS.

The great majority of all the waiters in the United States now are colored men, and the number is steadily increasing. A white waiter at a meeting a year or two back pointed out to his fellows that the colored waiters had got possession of three-fourths of the waiter work of the hotels in this country, and they were in a fair way to get hold of it all. While this is a true statement it is remarkable when it is reflected that it is only about forty years since colored waiters were unknown outside of the southern states. The recent death of John Lucas, the colored head-waiter of the great United States Hotel at Saratoga, (who died worth \$60,000) and the extensive newspaper mention which his death occasioned, has brought to light the fact that some of the aged waiters now living can name the men who first employed colored waiters in New York restaurants in 1846. The waiters employed in the immense hotels of Saratoga now are all colored; they are in the majority in New York, Boston, Philadelphia, Baltimore, St. Louis, and in all southern cities they have almost exclusive possession. They make the best of waiters and are learning better yearly. At present they have to be recruited from a rough and

uncared-for class to a great extent, from the boot blacks, scrubbers, sweepers, and farm and garden laborers, and many "hard cases" are found among them, but at the same time, in all the cities where the colored element is found in great and increasing numbers, the schools are turning out thousands of half-thought, half-polished young men who are almost entirely shut out from learning trades, and who come crowding into the waiters' ranks, finding there a species of occupation for which they are well fitted. It is likely, therefore, that these colored men are the coming waiters of this country, and that in the course of time the field will be left to them entirely. In the South they occupy all the ground as it is. Proprietors and other employers go South yearly who are resolved not to employ colored help, but almost invariably they have to abandon the resolution. The colored hands are there ready for anything. Guests find colored waiters more meek and obliging, less resentful and indifferent than white waiters. It is not long before changes take place and the colored hands get possession in spite of the previous intentions of the employers. Looking at it without prejudice it will be found that the colored boys have great advantages to fit them to be good waiters. An immense number of them have to begin life as house boys, as servant boys in the private houses of the South, and they get service and waiting, neatness, obedience and civility trained into them insensibly. Tens of thousands of these colored boys, while they are yet children, earn their subsistence by helping their mothers in private service, and get a preliminary training in waiting at private tables. These turn out to be hotel waiters without experiencing much difficulty. Another immense advantage of the colored boy is his freedom from over-sensitiveness. His feelings are not very high strung. He is used to the badinage of his own class. Colored people can revile each other and call opprobrious names to an extent that the most irascible white man would never

think of, but such abuse does not strike in; it rolls off the colored brother like water off a duck's back, and if he gets a rebuff at table he comes back smiling and says: "Now, Cap'n, I think you didn't ought talk so bad to me; ain't I treated you the very best I can? Ain't I been a real gentleman to you? Now, boss, if there's anything else you like to have jest say it and if it's in this house I'll get it sure." Then "boss" or "cap'n" laughs and throws him a tip, and thinks more of "the boy" than ever he did. Whether this submissiveness is going to continue as the race becomes better educated nobody can say, but it is an advantage to the colored boy at present, as it makes him the opposite of these complaining London waiters, who suffer apparently more in their mind than in their body. Says one, reporting the words of an address:

"The men to whom they sought to render assistance were exposed to many sorrows and troubles, dangers and difficulties. Some left homes perhaps of sorrow, to attend to the wants of others, and were obliged under the most depressing circumstances to look cheerful and pleasant. In addition to this, the waiter had to put up with many a scolding from those he waited on. He contended that in many instances the waiter was a far more gentlemanly individual than the one he waited upon."

And another: "Yet it must be acknowledged in all fairness that the waiter has a great deal to try him in the course of the day, and, if it were not for the expectation of liberal fees, it is probable that his nerves and his temper would give way far oftener than they do at present. It is the easy-mannered, the quick, quiet, respectful, and very long-suffering attendant who reaps the largest tips as a general rule."

And another: "There is but little question that of all the people under the sun the waiter is the most abused; and be a man ever so placid in temperament, the word 'waiter' has only to be mentioned and he flies more or less into a fury. Everyone who frequents hotels and restau-

rants (and who does not?) denounces the waiter—the choleric man becomes more choleric, and the cynic more sneering and sarcastic, and the waiter, flouted, scorned and detested on all hands, leads what may be called a far from particularly happy life. For thinly-veiled insults, for biting sarcasm and jeering sneers, and, more often than not, for downright bullying, the waiter must return politeness and meekness, and if, like the oft-quoted worm, he should dare to turn, he risks the double loss of situation and character.”

For this reason: “The dinner hour is a time when the guest is apt to be pleased or displeased with little things. There is an abrupt way of placing a salt-cellar on a table which is annoying; and no diner worthy of the name enjoys having his food thrust before him as if he were a wild beast at feeding-time at the Zoological Gardens.”

Such are samples of the sad complaints the white waiters have to make, and every word they say is true. Surely it is an advantage to the colored man that his skin is so thick these stings and arrows do not strike through, but he laughs through it all, and the man who dines goes away cheerful, too, and is not haunted by remorse.

---

SCENE—CITY RESTAURANT.

*First Client* (in a hurry): “Waiter, fried sole.”

*Second Client* (in a hurry): “Waiter, fried sole; fresh, mind!”

*Waiter* (equal to the occasion, shouting down tube): “Two fried soles—one of ’em fresh!”

---

TROUBLES COMMON TO ALL.

It is often remarked that waiters must above all things have good memories. The possession of a good memory itself, however, does not account for all the feats of a good waiter who carries in five or six persons' orders, comprising between two and three dozen different dishes differently cooked, and does not make a mistake in

one, though the obtaining of all may have taken him half an hour. There are plenty of men who can do everything else about a hotel, however seemingly difficult, who cannot take orders and remember them as far as the kitchen to save their lives. A good waiter was asked one day how he managed to charge his memory that way in spite of all the rush and noise in the kitchen. Said he: “I remember the order by repeating it over until I get my dishes; if it is six beefsteaks and two of them rare cooked, I get six steak dishes out of the hot closet and putting two at the bottom I say to myself, those two are for rare, the four on top are well done. I get four deep dishes for fish in cream, and so on, and once I get the dishes right I never can forget what they are there for. What breaks up the best of us is to come out and find all the dishes dirty and no spoons or knives to be had, and while we are hunting around we forget half our orders and have to guess at them.”

THE TYRANNY OF THE CHEF.

Another trouble common to all waiters is to be learned from this, making a little allowance for the exaggeration of the sums named:

“One of the best waiters in a wellknown down-town restaurant attended to the wants of a reporter on Thursday with a discouraged air. He spoke slightly of the beef, and feelingly remarked that he couldn't recommend anything except the salads. A choleric gentleman sat near the reporter, and the latter was astonished to hear the waiter advise him to try roast beef. In the restful pause that always waits upon the coffee the waiter was invited to explain his seeming inconsistency.

‘I had a row with the chef this morning,’ he said, ‘and I know that all the poor cuts are in store for me during the rest of the day. I wouldn't bring you something that wasn't good, you know.’

‘But you advised the red-headed gentleman to try beef.’

'The red-headed gentleman is opposed to tips, and so I haven't any special interest in his stomach. A waiter's life is not a happy one, and sometimes it is rendered miserable by little bickerings among the employés in the kitchen. Our wages are only \$30 a month and meals. If we are on friendly terms with the headwaiter he leads all the generous patrons to our tables, and if we are not it is a mere stroke of good fortune if we get a tip. Some of the waiters make from \$2 to \$4 a day besides their wages, while others don't make a dollar extra.'

'What does the headwaiter earn?'

'Oh, he frequently makes \$200 a month. His wages are \$50 a month, and the waiters are obliged to give him a percentage of all the tips they receive. There are about thirty waiters employed here, and it is a poor day when \$5 isn't turned over to him by the waiters at night. I have known him to receive \$10 at the close of a day. He has little influence over the kitchen, and in a case like the present, where a waiter is on bad terms with the people in the kitchen, he is apt to lose some of his best customers because he cannot get good meat for them. Some of the waiters propitiate the chef by treating him frequently, but this is expensive, and few of us can afford it. It is to our advantage of course to lose the customers who do not tip us, and I could spare the red-headed gentleman without a pang.'"

#### WANT OF BATHS AND DRESSING ROOMS.

Another trouble which all experience is the neglect of proprietors and stewards in many places to provide bath-rooms, wash-rooms, dressing-rooms and lockers for the waiters. The greatest possible stress everywhere is laid upon the necessity of waiters being clean in person and clothing, but frequently there are no conveniences whatever for washing and bathing and no places to leave a jacket or clean apron when it is not in use without risk of its being stolen.

The best of modern hotels have help's quarters fitted with plain but ample toilet

accommodations and these leave the waiters no excuse for being untidy.

#### A FEW TYPES OF WAITERS.

##### I.

There are incoherent waiters,  
And waiters who are rough;  
Apologetic waiters  
And waiters who are tough.  
There are waiters quite forgetful  
And absent-minded, too,  
And waiters always waiting  
For that little tip from you.

##### II.

There's the waiter at Delmonico's  
With his blank, Parisian stare,  
Who calls the butter *beurrey*,  
The potatoes *pome de tare*,  
Who comes with supercilious air  
In answer to your call,  
As if it were an honour  
To notice you at all.

##### III.

There's the absent-minded waiter  
Who is always in a flurry,  
And who brings you currant jelly  
When you call for chicken curry;  
Who pours the sugar on your meat,  
The salt into your tea,  
And finally reduces you  
To abject misery.

##### IV.

The apologetic waiter,  
With his sweet, eternal smile:  
Who lays his head upon one side  
And rubs his hands the while,  
Who is "really very sorry  
That we haven't that to-day,"  
And who thinks it "Quite unfortunate  
That it's cooked in such a way."

##### V.

There's the large and clumsy waiter  
Who is always very slow,  
And is forever stumbling  
Wherever he may go;  
Who drops the butter on your coat  
With great proficiency,  
And crowns you with the muffins  
With extreme dexterity.

##### VI.

There's the thin and sporty waiter  
Who never takes your hat,  
And makes a bowling alley  
Of the table you are at.  
Who rolls the dishes down on you  
Regardless of their falls,  
As if you were a nine-pin  
And they were bowling-balls.

## VII.

There's the waiter at the seaside,  
 With his life of gilded ease;  
 He's the one who's always waiting  
 For those customary fees.  
 He will starve you to submission  
 If his tip you should refuse,  
 But treats you like a monarch  
 If you give to him his dues.

## VIII.

There's the shabby-genteel waiter,  
 Whose clothing never fits;  
 Who always brings your change to you  
 In five and penny bits;  
 And who also serves your dinner  
 In sections, plate by plate,  
 And sets it down before you  
 Like an avenging Fate.

## IX.

There's the waiter that's attentive  
 And exceedingly polite,  
 Who sees that what you order  
 Is served exactly right;  
 Your merest wish anticipates  
 With such a cheerful will;  
 Though you mean to tip a quarter  
 He often gets a bill.

## X.

He's the waiter that's successful,  
 For he does his work so well  
 That in certain length of time  
 He owns his own hotel;  
 And stands beside the cashier's desk  
 And looks with lordly air  
 Upon all the other waiters  
 Who are waiting for him there.

*New York World.*

## RUM OMELET STRAIGHT.

"Tired" Customer (in restaurant) —  
 Wait'r, a (hic) rum omelet!  
 Waiter—Yes, sir; with er without eggs?

## JUST A PLAIN WAITER.

"In Washington you can get a highly seasoned and not entirely objectionable compound of Terrapin, in exchange for a moderate fortune, served up with Saratoga chips and a grand flourish by a haughty waiter, who will ostracize you socially afterward if you forget to give at least a dollar for himself. But walk into one of the right places in Baltimore, hang your

hat up carelessly, and quietly follow these respectful suggestions: 'Po'tion o' tar'pin? Yezzah. Some nice sullery? Yezzah. Brown chips? Yezzah. Pinter Perry Juray? Yezzah!' and in about five minutes you will have a feast fit for the gods."

## DIDN'T MAKE IT THAT TIME.

"In his entertaining book, 'The Ambassadors of Commerce,' Mr. Allen tells the following little story: The Saracen's Head Hotel, Lincoln, was noted for three things: a very gruff landlord, a very cheeky waiter and '365.' The latter term being a synonym for the very best rice-pudding I, or anyone else, ever tasted, and as it was produced every day in the year, we christened it '365.' I can vouch for it being on the table twice a month for twenty-two years, and always good alike. I may add that if half a dozen were required they were always forthcoming. But it is of Arthur the waiter I would speak. It was often suspected that this swallow-tailed, modest-looking *garçon* was guilty of removing the decanters, and especially the small black bottles of crusty, 'bee's-wingy' old port before they were quite empty; this was especially noticed by a Mr. Thomson, a sharp-witted 'commercial,' who on the day in question hinted the fact to the president. It was a rather large dinner-party, and Arthur was in unusually good form. A pint of old port was ordered and emptied; the bottle was partly refilled with salt, pepper, cayenne, mustard, Worcester sauce, chili vinegar, anchovy, etc. 'Bring the bill, Arthur,' said the president. 'Yes, sir!' and as usual Arthur hurriedly took off the black bottle. The company waited some time, but no Arthur and no bill appeared. Whereupon the 'vice' was asked to ring the bell. In came 'Buttons.' 'Tell Arthur to bring the dinner bill at once,' said the president. 'Please, sir, he can't; he's nearly dead, he's choked.' The gentlemen at the table became alarmed, hurried out of the room to find poor Arthur in a most painful position. He was black in the face, and surrounded by his fellow-servants.



On his recovery he solemnly promised never again to test the quality of leavings in the black bottle.

## A WAITERS VALENTINE.

"It is prosaically addressed to 'Sally at the Chophouse,' and bears date Feb. 14, 1799:

"Dear Sally,—Emblem of thy Chophouse ware,  
As broth reviving, and as White Bread fair;  
As Small Beer grateful, and as pepper strong;  
As Beef Steaks tender, and as fresh Hot Hearts  
    young;  
As sharp as Knife, as piercing as a Fork,  
Soft as New Butter, white as fairest Pork;  
Sweet as young Mutton, brisk as Bottled Beer,  
Smooth as is Oil, juicy as Cucumber;  
As bright as Cruet, void of Vinegar.  
Oh, Sally, could I turn and shift my Love  
With the same skill that you your Steak can move,  
My Heart thus cooked might prove a Chophouse  
    feast,  
And you alone should be the welcome guest.  
But, dearest Sal, the flames that you impart,  
Like Chop on Gridiron, broil my tender heart,  
Which, if thy kindly hand ben't nigh,  
Must, like an unturned chop, hiss, burn, and fry,  
And must at last, thou scorcher of my soul,  
Shrink, and become an undistinguished coal!"

## A WAITER'S WIFE.

"Bertha Stuckart, wife of a waiter in Vienna, Austria, won a prize for her beauty at the exhibition of beautiful women at Spa, Belgium. Her husband sold her, by mutual agreement, to a rich bachelor for a considerable sum, and now she has obtained a profitable engagement with a museum proprietor to make a tour of the world."

## STUDENT WAITERS.

A watering-place correspondent says: "Passing through the dining room of a summer hotel one afternoon I saw the headwaiter, a fine, handsome young man from one of our New England colleges, reading Virgil with several of his assistants the pretty waitresses, who in other places are school teachers, and very likely in colleges themselves. I thought of the Hotel Zum Anker at Coblenz on the Rhine, and a young man I met there—a German Baron I think he was—and with whom I talked

of America and American hotels, and especially I told him of the student waiters in our summer hotels. He expressed great astonishment, and said he had heard of it before, but never had been able to bring himself to believe it. His incredulity was all the more surprising, as he himself was a clerk at the Hotel Zum Anker. I must give him the credit of being an excellent clerk, who never seemed to forget that though he was a baron he was yet the hotel clerk, and so discharged his duties just as faithfully as though he had not been possessed of so hair-splitting a turn of mind."

## IN THE WHITE MOUNTAINS.

'Twas at college first I met him,  
There competing for a prize;  
And he gave his deep oration.  
All his soul within his eyes.

'Twas a masterpiece, in Latin,  
Full of feeling, fire and thought,  
Rich with wild poetic fancies  
Thro' the phrases interwrought.

And his proud young face shone on me  
And his clear young voice rang loud,  
Leaving in my ear an echo  
O'er the plaudits of the crowd.

Thus I listened, thrilled, enraptured,  
Hung on every ringing tone,  
Till the heart within my bosom  
Beat for him, and him alone!

On my breast I wore his colors,  
Love's sweet tribute to his fame;  
And while thinking of him ever  
To my heart I called his name.

And we met again—'twas summer;  
I had waited long and well.  
I was down beside the seashore,  
Stopping at the Grand Hotel.

Seated all alone at dinner,  
Wrapped in serious thought was I,  
When a voice, so deep and tender,  
Murmured, "Peach or lemon pie?"

Then I looked up, pale and trembling,  
There "he" stood within my sight,  
In a waiter's badge all shining,  
And a waiter's apron white.

He had hired there for the summer,  
And his wild, poetic heart  
Now was struggling through the mazes  
Of a dinner a la carte.

So I turned me coldly from him,  
 With a sad and sobbing sigh;  
 After all my weary waiting  
 All I said was "Lemon pie!"

That lady went back the next year and found he had become a majestic headwaiter like this:

"Mrs. De Timid (at Grand Hotel table)—I beg pardon, but didn't you say you were presented to the queen during your tour abroad?"

Prima Donna—"Yes madam."

'And you spoke of other experiences of a like nature.'

'I was presented to several of the crowned heads of Europe, talked with many of the great generals and noted diplomats and was granted an audience.'

'Weren't you scared?'

'Not at all.'

'Then if you are not afraid, I wish you would tell the headwaiter that this salt box is empty.'



A TREASURE OF A WAITER.

"A tight pair of light pants, a shirt of which the bosom shone like a bald head, a Rhine-stone collar-button which fastened an immaculate collar to the aforesaid shirt, a black alpaca round-about and an apron that just escaped the floor, and inside of all a human being, and you have our new waiter. With the exception of an embryonic moustache his face was devoid of hair. He had had several years' experience, he said, as a waiter, and it was with a feeling

of pride, to say nothing of relief, that the headwaiter saw him take his place in the centre of the room and await the rush that always occurs at high noon. One by one tables were filled, and finally not a seat there was to be had. The new waiter passed



noiselessly from one table to another, taking the multitude of orders with the utmost complacency until he reached the end of his station. 'At last I've got a man that can take care of my customers in a proper manner,' chuckled the proprietor, as he gazed with pardonable admiration on the new man awaiting his turn at the order-lift. His satisfaction was short-lived, however, for all at once the new waiter began giving orders in a voice suggestive to the bellow of a bull, and that, too, in a vernacular that was strangely new to the Brotherhood Restaurant:

'(1) Give me a stack o' whites with a copper on (2) a terrier without shamrocks, (3) some hen's fruit that an't over ripe, (4) a slaughter-house and a paralyzed Mick, (5) a cup of coffee on crutches, (6) two

insults to a square meal, (7) one Sheeny destroyer and a soaked bum, (8) a brownstone front, and (9) return good for evil.'

A cry from the kitchen followed, and the carver ran upstairs saying the *chef* had fainted. The new waiter was summarily bounced and an old hand sent to get the orders anew, which having done, he transmitted to the kitchen as follows:

'(1) Give me a plate of wheat cakes well browned, (2) corned beef without cabbage for one (3) a plate of fresh fried eggs, (4) steak and a boiled potato, (5) a cup of coffee half mi.k, (6) two dishes of hash, (7) a plate of roast pork and pickled beets, (8) pork and beans for one, and (9) change this potato for a good one.'

This is what the new waiter *meant*, but he had had too many days' experience in the shady part of town."

#### TRIALS OF THE WAITER GIRLS.

"Crank," said the girl waiter, "always blossom out in their full glory when they eat. Some of them never know enough to give an order and five minutes after it is cooking will want me to change it. Of course I can't do it. Then there is the young man who is inclined to be spooney and indulges in any amount of soft nothings, forgetting that I have not let this leap year pass without getting an iron-clad engagement, and if my fellow attempts to go back on his vows I will make it too warm for him to live. But there is one kind of crank that is the meanest of all—the one who comes in with a friend, and when he sees anything his friend has ordered that pleases him deliberately appropriates it. This always creates bad feeling, and the blame falls on me. I thought I would get even with one of this kind last night, and checked him up an extra quarter. But I

failed. He traded checks and paid his bill and went out, and his patient friend caught the large sized check."

#### WAITERS' CHRISTMAS.

(*Chicago Hotel World.*)

Mr. Plummer, headwaiter of the Millard, Omaha, received a costly manicure set from his waiters.

Mr. O. H. Lane, headwaiter at the Hotel Worth, Chicago, besides other gifts, received about \$40 in hard cash from the guests of that hotel. The side-waiters also fared well.

Ms. Albert E. Reynolds, headwaiter of the St. James Hotel, St. Louis, was generously remembered by his waiters with a fine ring, bearing his monogram inlaid with diamonds.

Julia Harrigan has been head waitress at the Morton House, Grand Rapids, Mich., for over ten years, and her friends made her a Christmas present this year of \$230 in cash, collected in small donations.

The St. Louis, *Hotel Reporter* says the Southern Hotel Company distributed about fifteen hundred dollars among their employés and allowed them to purchase their presents. The proprietors of the Lindell also came to the front in a liberal manner.

Mrs. Potter Palmer gives a Christmas the Palmer House, Chicago, in the hotel parlors. At the recent treat over 200 children, (says the *Chicago Hotel Reporter*), assembled around a monster Christmas tree laden with valuable presents, and every child was made happy with a gift. After the presentations the little ones were given a banquet with plenty of ice cream, cakes and candies in the bill of fare. It is such substantial manifestations of good will upon the parts of employers that tends to make employés contented and happy.

THE BOOK YOU HAVE ALL BEEN WISHING FOR!

THE  
EPIGUREAN ❖ DICTIONARY,

OR,

HOW TO ORDER DINNER.

A

*POCKET CYCLOPÆDIA*

OF

GASTRONOMY AND CULINARY ART.

BY

JESSUP WHITEHEAD.

---

The Dictionary of Dishes, which commences on the following page, is also issued separately in pocket-form, with the above title. It is intended for all who need such a work of reference, yet do not require a complete hotel book of stewarding, etc. It is for those who wish to dine intelligently from a French menu, for those who write and print bills of fare, and those who would criticise them; for the club steward seeking novelties; for the tourist going abroad; for the restaurateur, for his *chef*, who will glance at it to be reminded which is which among hundreds of sauces and soups with their minute differences and special ingredients, and for men in the business who are in want of new things to sell. The book will be found well stored with bright sayings and pertinent anecdotes. It will make a valuable and handsome present for any one.

Pocket Size, Cloth, Full Gilt, Price \$1.<sup>50</sup>.

---

*Jessup Whitehead,*

PUBLISHER,

183 NORTH PEORIA STREET, - - - CHICAGO.

# THE STEWARD'S HANDBOOK.

PART FOURTH.

---

## WHITEHEAD'S DICTIONARY OF DISHES

CULINARY TERMS AND VARIOUS INFORMATION PERTAINING TO  
THE STEWARD'S DEPARTMENT, BEING THE

*ESSENCE OF ALL COOK BOOKS,*

TELLING IN BRIEF WHAT ALL DISHES AND SAUCES ARE, OR  
WHAT THEY SHOULD LOOK LIKE.

WHAT MATERIALS ARE NEEDED FOR AND WHAT THEY ARE.  
HOW TO USE TO ADVANTAGE ALL SORTS OF ABUND-  
ANT PROVISIONS, OR HOW TO KEEP THEM.

CONTAINING, ALSO,

A Valuable Collection of Restaurant Specialties,

DISTINCTIVE NATIONAL COOKERY,

REMARKS ON ADULTERATIONS, AND HOW TO DETECT THEM,  
TREATMENT AND SERVICE OF WINE

AND A FUND OF CURIOUS AND USEFUL INFORMATION IN DICTIONARY FORM,  
FOR STEWARDS, CATERERS, CHEFS, BAKERS, AND ALL  
HOTEL AND RESTAURANT KEEPERS.

---

BY

JESSUP WHITEHEAD.

---

CHICAGO.  
1889.

---

Entered according to Act of Congress in the Office of the Librarian, at Washington, by  
JESSUP WHITEHEAD, 1889.—All rights reserved.

---

CHICAGO, ILL.

JOHN ANDERSON & Co., Printers, 183-187 N. Peoria St.

# MODEL SMALL MENUS.

## DINNER PARTY AT ADELPHI HOTEL, NEW YORK.

Blue Points.  
Chicken à la Reine.  
Kennebec Salmon, Anchovy Sauce.  
Pommes Parisienne.  
Olives. Celery.  
Terrapin à la Maryland.  
Chicken Croquettes Petits Pois.  
Cauliflower.  
Fillet of Beef, larded, with Mushrooms.  
Mashed Potatoes.  
Lobster and Chicken Salads.  
Canvas-back Duck.  
Saratoga Chips. Currant Jelly.  
Rum Omelette.  
Cheese, Fruit, etc.  
Café, Liqueurs, Segars.

## ITALO-AMERICAN EPICUREAN CLUB RECEPTION, NEW YORK.

Julienne.  
Variés. HORS D'ŒUVRE. Variés.  
Striped Bass à la Hollandaise.  
Beef Tenderloin, with Mushrooms.  
Potato Croquettes. French Peas.  
Roast Chicken. Turkey.  
Lettuce Salad. Celery. Cranberry Sauce.  
Lobster Salad.  
Chicken Mayonnaise.  
Vanilla Ice Cream.  
Assorted Cake. Fruits. Bonbons.  
Candy.  
Cheese. Coffee.  
Liquors.

## COOK'S ASSOCIATION, LONDON EX- HIBITION.

### MENU.

#### *Soups.*

Julienne.

#### *Fish.*

Tranches de Saumon, Sauce Verte.  
Blanchailles.

#### *Entrees.*

Poulet Sauté à la Portugaise.

#### *Relevés.*

Quartier d'Agneau, Sauce Menthe.

#### *Second Service.*

Canetons Rôti.  
Salade à la Française.  
Asperges, Sauce Hollandaise.

#### *Entremets.*

Babas, Sauce Abricot.  
Glacé à la Vanille.  
Gâteau Assorti.

## COMMONWEALTH CLUB, METROPOL- ITAN HOTEL, NEW YORK.

### MENU.

Blue Points.  
Consommé de Volaille aux Quenelles.  
Baked Bluefish, Bordelaise.  
Cucumbers. Potatoes au Gratin.  
Leg of Mutton, Caper Sauce.  
String Beans.  
Porterhouse Roast à l'Anglaise.  
French Peas.  
Cardinal Punch.  
Spring Turkey, Cranberry Sauce.  
Lettuce. Brussels Sprouts.  
Pudding à la Reine.  
Glacé à la Forme.  
Gateaux Assortis.  
Fruit. Coffee.  
Cheese.

## ANOTHER OF THE SAME.

### MENU.

Blue Points.  
Consommé Deslignac.  
Boiled Kennebec Salmon à la Russe.  
Cucumbers. Potatoes Brabant.  
Sirloin of Beef, larded Jardinière.  
Cauliflower au Gratin.  
Salmi of Partridge à la Perigeux.  
String Beans.  
Roman Punch.  
Philadelphia Capon, Water-cress.  
Green Peas.  
Cabinet Pudding, Brandy Sauce.  
Neapolitan Ice Cream.  
Assorted Cake.  
Cheese. Fruit.  
Coffee.

## AL FRESCO.

An enthusiastic tourist thus describes a supper of which he partook recently upon an island in Lake Erie: "And such a supper! Black bass killed twenty minutes ago, cut up and fried to an external crisp and internal juicy firmness; grass pike baked whole and done to a turn, which would strike envy into the very stew-pans of a French 'artist;' a peck of little perch fried as crisp as shavings and as 'sweet as nuts;' a half dozen roast mallard, stuffed with soul ravishing sage and onions; a pot pie from whose delicious depths coots, reed birds, snipe and teal emerge in succession; potatoes roasted in their jackets, and best of all, tin plates, wooden benches, the glorious back-woods, absence of etiquette and every man for himself."

## AN ACROSTIC MENU.

The following complimentary *menu* to a young lady named Lilian does credit to its author:

L es huitres d'Ostend.  
 I talian et Printanier Royal.  
 L ottes à la Massillon.  
 I ndienne de riz sur croustades.  
 A iguilletes de canards St. Hubert.  
 N oisettes de pré salé, Lyon d'Or.  
  
 B ombe à la Romaine.  
 O rtolans et perdreaux eur canapés.  
 N ouilles en timbales à la Napolitaine.  
  
 V élouté de cardons à la moëlle.  
 O melette soufflée à vanille.  
 Y okohama glacé au Clicquot.  
 A bricots et fruits confits.  
 G auffrettes et petits fours.  
 E spalier de chasselas Fontainebleau.

Possibly the waiters were as much in a *maze* about the order of serving such a feast as the guests were amazed at the delicacy of the giver thereof.

#### CANARD, SAUCE AU SANG.

One of Joseph's little dinners. (M. Joseph, of the *Restaurant du Cafe Paillard*, Boulevard des Italiens, formerly of Bignon's.)

##### MENU.

Huitres d'Ostende.  
 Potage au Tapioca, à la Purée de Pois,  
 à l'Oseille.  
 Turbot, Sauce Hollandaise.  
 Côtelettes d'Agneau braisées à la Purée de Cham-  
 pignons.  
 Canard Sauvage Rôti, Sauce au Sang.  
 Salade.  
 Tomates au Gratin.  
 Riz à l'Imperatrice aux Mandarines.  
 Fromage et Fruits.  
 Pontet-Canet, 1875. Cardinal, Sec, Frappé.

#### AN ENGLISH PRIVATE PARTY.

##### MENU.

Ox-tail Soup.  
 Turbot and Lobster Sauce.  
 Filleted Soles.  
 Oyster Pudding.  
 Kidneys, with Mushrooms.  
 Saddle of Mutton.  
 Turkey.  
 Grouse. Pheasant.  
 Wine Jelly. Apricot Cream.  
 Cheese. Canapés.  
 Cheese and Celery.  
 Ice Pudding. Dessert.

#### AT A SCOTTISH NOBLEMAN'S.

##### MENU.

Potage des Asperges. Purée de Navets.  
 Fried Soles. Halibut.  
 Rabbit à la Kirkham. Roast Crawfish.  
 Chicken à la Marengo. Quails à la Princess.  
 Roast Lamb à la Dudley.  
 Roast Grouse.  
 Imperial Pudding. Broiled Peaches and Cream.  
 Pistachjo Fritters. Cream Cheese Fritters.  
 Lemon Jelly. Strawberry Cream. Ices.  
 Dessert.

#### AT A COLD BALL SUPPER.

The following is the menu of one of the largest ball suppers given during the past winter season, and served by the leading local caterer:

##### MENU.

Raised Pies (Veal and Ham, Pork, Game, etc.).  
 Roast Fowls. Pressed Tongues. York Hams.  
 Mayonaise of Salmon. Lobster in Aspic.  
 Galatine of Veal. Sandwiches. Boned Turkey.  
 Italian Salads. Sweet Salads of Fruits.  
 Topsy Cakes.  
 Neapolitan Gâteau. Creams. Jellies.  
 Ices.

#### A HOT SUPPER OF THE SAME CLASS.

##### MENU.

Soup à la Reine. Asparagus Soup.  
 Salmon.  
 Truffled Turkey. Ox Tongue. Sirloin of Beef.  
 Lamb. Broiled Chicken. Yorkshire Ham.  
 Game Pie. Pheasants.  
 Trifle. German Pastry.  
 Fruit Jelly. Creams.  
 Fruit.

The menu-cards were pretty, no two being alike, yet all of delicate design.

#### DINNER GIVEN BY A PHYSICIAN.

A dinner given by one of the medical attendants of the late Prince Leopold.

##### MENU.

Clear Soup.  
 Salmon.  
 Oyster Patties.  
 Sweetbreads.  
 Lamb.  
 Guinea Fowls.  
 Orange Pudding. Claret Jelly.  
 Anchovy Toast. Cheese.

#### A GERMAN MODEL MENU.

At the Windsor Hotel, Edinburgh, a dinner was given in honor of the German Emperor's ninetieth birthday. There were about fifty gentlemen present, of course mainly composed of Germans, but here and there were to be seen Scotchmen and Englishmen. The viands were composed largely of German dishes, but amid the foreign names loomed the untranslatable word "haggis," the familiar Scottish national dish. On the *menu* card was an excellent portrait of the emperor, and the viands were as under:

Kaiser Suppe. Hühner Suppe.  
 Sherry.

Lachs, mit Hummer Sauce. Gebackene Seezunge.  
 Niersteiner.

Leipziger Lerchen. Kalbskopf.  
 Haggis.  
 Schaumwein. Whisky.

Sauerbraten und Klösse.  
 Haasenbraten und Weinkraut.

Junge Hühnen und Enten.  
 Compot und Salad.

Sächsischer Auflauf. Apfelkuchen.  
 Süsse Sulz.  
 Rothwein. Sherry.  
 Nachtsch.



## THE GERMAN EMPEROR'S DINNER.

The following is a copy of one of the last gala dinners which *chef* Urbain Dubois prepared for his illustrious employers, and of which, as well he might, "All-Highest-the-Same" ate very heartily:

Hühnerbrühe mit Spargel-Köpfen.  
Schild-Kröten-Suppe.  
Gebirgs-Forellen, blau.  
Lendenbraten mit Kaviar-Brödchen.  
Warme Rebhühner-Pasteten mit Trüffeln.  
Helgoländer Hummer.  
Brüsseler Geflügel.  
Bömishe Fasanen. Salat.  
Artischocken-Bohnen mit jungen Gemüsen.  
Pils in Petersilie.  
Butter und Käse. Früchte. Eis. Nachtisch.

## JUBILEE SUPPER AT LANSDOWNE HOUSE.

The menu of the jubilee supper at Lansdowne House, which received very special commendation from the Prince of Wales, was as follows:

Tortue claire.  
Filets de soles à la Ravigotte.  
Cailles flanquées, d'ortolans.  
Filets de volaille à la Parisienne.  
Asperges à la sauce Hollandaise.  
Souffles glacés Panaches.

This is a very simple repast, for since the Prince of Wales' digestion lost the edge of youth he has been urging every one to give simple dinners. It is made up of five courses: Clear turtle soup; filets of sole, served with Ravigotte sauce (a maitre d'hotel sauce with Chili vinegar, anchovy, etc.); quail flanked with ortolans; filets of fowl à la Parisienne, asparagus with Hollandaise sauce (yolk of eggs and butter with vinegar); and a soufflé with harlequin ices.

## MR. IRVING'S BEST DINNER.

In Irving's "Impressions of America" due prominence is given to the lavish feasting which attended the well-known artist's triumphal progress through the states. He was greeted everywhere with complimentary entertainments. As for the *menus* of some of his smaller banquets, they make one's mouth water; and Mr. Irving is evidently an intelligent and scientific *gourmet*. He seems to have given the palm to a simple little dinner at Sieghortner's in New York. Oysters on the half shell, lying on crushed ice, each served with its separate slice of lemon. A vegetable soup that reminded him of what he barbarously misspells as "Cock-u-lukie." Terrapin sent up hot and hot. ("Next to going to heaven," said a friend near me, is to go down to Baltimore and eat terrapin.") Canvas-back duck—a breast on each plate, with potato chips and celery, and two courses of the ducks, the first roasted, the second grilled and devilled. A soufflé, cheese, coffee and wines that were worthy of the fare. By way of contrast to that little *diner soigne*, we have an amusing account of a "scratch" dinner given by Irving to his company at a hotel at Toronto in the winter, and consequently out of season. After telegraph and telephone had been

working in all directions, flashing fruitless messages for poultry and other raw material, seventy guests were set down at last to a sufficiency of substantial food.

Private dinner to the Prince and Princess of Wales:

Consommé de Volaille Royale.  
Crème d'Asperges à la Comtesse.

Turbot braisé à la Vatel.  
Mousse de Saumon à la Lavallière.

Côtelettes d'Agneau Châtelaine.  
Médallions de Foie-gras à l'Aspic.

Hanche de Venaison.  
Poulardes Soufflés.

Ortolans sur Canapés.  
Petits Pois à la Français.

Parfait léger aux Cerises.  
Gâteau Napolitain

Tartelettes Suisses.

First official dinner given by President Carnot at the Elysée:

Consommé Bagration.  
Bisque d'Ecrevisses.

Bouchées aux Crevettes.

Saumon, Sauce Génévoise.  
Cuissot de Chevreuil Saint Hubert.

Suprême de Volaille aux Truffes.  
Côtelettes d'Agneau aux Petits Pois.  
Mauviettes à la Lucullus.  
Salade d'Homard à la Russe.

Sorbets.  
Faisans truffés, Sauce Périgueux.  
Pâtés de Foie Gras de Nancy.

Asperges en Branches.  
Haricots Verts Nouveaux.

Glacé Diplomate.  
Gâteaux Mousseline à l'Orange.

Menu of a dinner given by the Sultan of Turkey to the Prince Jérôme Napoléon on the 1st of July:

Potage à la reine.

*Beureg.*

Poisson à la Turque.  
Filet de bœuf à la Godard.  
Poulets nouveaux à l'Orientale.  
Côtelettes d'agneau aux petits pois.

*Hiar Dornassy.*

Homards en Belle-vue  
Asperges bouillies, sauce au beurre.

*Punch à la Romaine.*

Dindonneaux rôtis au jus.

*Pilau.*

Visnali ekmeg.  
Gelée macedoine de fruits.  
Faouk gheuksu.  
Fromage glacé.

## A KING FLUSH AND A ROYAL DINNER.

Menu of a notable dinner given by Earl Cadogan at Chelsea House to the royalties in London. Covers were laid for forty-eight. The company in-

cluded the King of Denmark, the King of Greece, the King of the Belgians, the Crown Prince of Austria, the Prince and Princess of Wales and Princesses Louise and Victoria of Wales, the Crown Prince and Crown Princess of Portugal, the Crown Prince of Sweden, the Grand Duke and Grand Duchess Serge of Russia, the Duke of Aosta, Prince and Princess William of Prussia, the Infante Antonio and the Infanta Eulalie, and the Hereditary Prince and Princess of Meiningen.

## MENU.

Consommé à la Royale.  
Crème d'Asperges.

## Whitebait.

Filets de Truites froides en Souchet.

Côtelettes d'Agneau Duchesse.  
Chaufroid de Cailles aux Truffes.

Poulardes aux Pruneaux.  
Filet Piqués froids, Sauce Cumberland.  
Salades Russe et Tomates.

Ortolans sur Canapés.  
Pois à l'Anglaise.

Bavarois à la Montreuil.  
Soufflés de Fraises.  
Croustades aux Fromages.

## WHEN PRINCE MEETS PRINCE.

Menu of a dinner given by the Crown Prince Rudolph of Austria to the Prince of Wales on the 24 of September, 1888, at the "Lacher Garten," Prater, in Vienna:

Huîtres.  
Consommé à la Sevine.  
Bisque d'écrevisses.  
Saumon du Rhin, sauce Hollandaise, et sauce Genevoise.  
Piece de bœuf, à la jardinière.  
Pâté de canard truffes, à la gelée.  
Poulardes à la Toulouse.  
Ponche Stephanie.  
Selle de chevreuil. Faisans de Bohème.  
Salade.  
Fonds d'artichants à la moëlle.  
Soufflé au chocolat.  
Glacés historiées. Fruits. Fromage.  
Café.

## AN EXCELLENT DINNER

at the house of one of the most elegant of the *grandes dames* of Paris:

## MENU.

Consommé Royal.  
Tartelettes à la Russe.  
Filets de Turbots Chambord.  
Selles de Marcassin, Sauce Tartare.  
Casseroles de Ris de Veau Petits Pois.  
Bartavelles aux Ceps de Bordeaux.  
Marquises Jamaïque.  
Dinde truffée. Salade.  
Foies Gras Lumineux Truffés.  
Cardons à la Moëlle.  
Bombe Grande Duchesse.  
Fromages. Desserts.

## A NOVELTY

"This was one of the best dinners I have had for some time. I want specially to call your attention to the item *foies gras lumineux truffes*, which is a

very attractive novelty. The dish is a hollow cone of tinted ice. Inside the ice is placed a light. Along the sides of the cone are laid rows of roundels of *foie gras*, diminishing in size from bottom to top. In each roundel is a slice of truffle. The light shining through the ice has a wonderfully pretty effect, whilst the cold keeps the *pate de foie gras* firm and fresh as it should be. Another variety is to set the *foie gras* in slices on a large block of ice in the centre of the table, the ice to be made luminous in the method described. I recommend this novelty to the attention of hotel keepers who do elegant dinners, or even for first-class *table d'hotes*."

## DRAMATIC SUPPER.

"Supper served on the stage of the Gaieté Theatre here on the occasion of the 100th representation of *Le Grand Mogol*, and offered by the lessee, Mr. Debruyère, and the authors of the piece, to the actors and many representatives of Paris art, literature, society, and finance:

Potage Irma, Consommé Bengaline.  
Truites du Gange, Sauce Brahma et Sauce Vischnou.

Filet Mignapour aux Truffes et aux Champignons.  
Jambon Crakson aux pointes d'Asperges.

Faisans et Perdreaux des Jungles.  
Pâté de Foie Gras à la Joquelet.

Salade Bayadère.  
Bombe Nicobar.  
Dessert.

## VINS.

Bordeaux retour de l'Inde et Champagne  
Grand Mogol.  
Café. Liqueurs.

You will perceive that the *colour locale* is well preserved."

## A GOOD MENU.

"The following is a good menu, as I can vouch from personal experience:

Consommé aux œufs pochés.  
Aloyau Portugaise.  
Timbale de macaroni.  
Cailles rôties.  
Cardons à la moëlle.  
Charlotte de pommes.

"Here is the recipe for the *Aloyau Portugaise* mentioned above: Prepare a piece of *faux-filet*; lard it; steep it in a little olive-oil and cognac-brandy for an hour before cooking. Have stuffed tomatoes and roast with your *faux-filet*. When it is ready place the tomatoes round the meat and pour Madeira sauce over the whole."

## GOOD COOKING IN POLITICS.

The *World's* statement commences as follows: "Lord Cadogan's *chef* is unquestionably a factor in politics, for the Lord Privy Seal's Saturday dinners are, in their way, almost as important as Lady Salisbury's Wednesday receptions." Our contemporary then goes on to praise the white dining room of Cadogan House, and to describe the dinner to a distinguished company, of which M. Isoard sends us the menu here transcribed:

Consommé Profiteroles.  
Crème d'Orge à l'Écossaise.

Filets de Truites, Sauce Gènevoise.  
Soufflés d'Eperlans.

Cailles aux Raisins.  
Côtelettes d'Agneau aux Concombres.

Filet de Bœuf piqué, Sauce Madère.  
Légumes.

Sorbets au Rhum.

Poulets d'Inde au Cresson.  
Pains d'Épinards à l'Espagnole.

Babas à l'Allemande.  
Neiges au Moka.  
Biscottes au Fromage.

#### A CHINESE DINNER IN NEW YORK.

Excise Commissioner William S. Andrews, who has for years been ambitious to eat a regulation Chinese dinner, ate one last night, and thinks that he will be able to get out to-day. Wong Chin Foo was his host. Dressed in an American derby and overcoat and other American things, Wong led the way to the Chinese chop house at 14 Mott street. The Commissioner was in evening dress. He brought along two New York friends to help him, and when they had mastered the chopsticks they drove right through fourteen courses of dinner without quailing. It took nearly three hours, and this was the bill of the performance:

1. Tea, served in costly china cups.
2. Cake.
3. Lichee nuts.
4. Sweetmeats.
5. Roast duck.
6. Roast chicken.
7. Boned ducks feet fried, with mushrooms and bamboo shoots.
8. Chicken bones fried in lard until the bone was soft as the flesh, and dressed with Chinese sweet pickle, ginger and celery.
9. American pike fried, with mushrooms and water lily potato.
10. Cuttlefish, with Chinese sweet turnips and saifun beans.
11. Tchownien macaroni, flour stewed with chicken, celery and mushrooms.
12. Chinese sausages, composition uncertain.
13. Citron soup, with shrimps.
14. Lotus seed and apricot seed soup.

Commissioner Andrews washed it all down with three kinds of Chinese wine. One was the nomai-dayo pear wine, the second a white wine distilled from rice, and the third Chinese gin made of apricot seed.

#### A MEXICAN MENU.

The Mexican idea of the first meal in the morning is a cup of coffee and a small loaf of bread or biscuit. The guest may have that in his room if he likes, and he can have it supplemented with a beefsteak or eggs. At twelve o'clock dinner—la comida

—is ready. A bill of fare, just as brought from the table of the Jardin, is subjoined in Mexican and translation:

#### MENU DE LA COMIDA.

*Sopas.*  
A la Romana.  
Arros.  
*Entradas.*  
Huevos al gusto.  
Huachinango à la Matelot.  
Beefsteak o'costillas.  
Japonesas de salmi.  
Salchichas conchiharos.  
Fernerita con salpicon.  
Chiles rellonos.  
*Asados.*  
Roastbeef.  
*Legumbres.*  
Califlores.  
Papas al vapor.  
Frijoles.  
*Pastres.*  
Fresas—helado.  
Cafe, tee.

#### DINNER BILL OF FARE.

*Soups.*  
A la Romada.  
Rice.  
*Entrees.*  
Eggs in all styles.  
Red snapper à la Matelot.  
Beefsteak or mutton chops.  
Chicken croquettes.  
Sausages with green peas.  
Roast veal.  
Stuffed chillies.  
*Roasts.*  
Roast beef.  
*Vegetables.*  
Cauliflower.  
Boiled potatoes.  
Beans.  
*Dessert.*  
Strawberries—ice cream.  
Coffee, tea.

This meal is \$1. The dishes are served one at a time. A foreigner may be a little surprised at first to find eggs elevated to such an important position in the bill of fare—they follow the soup—but he speedily discovers that Mexican eggs are always fresh, and he takes his "huevos" boiled, fried, or in omelet as regularly as the dinner comes round. The Mexican cooks have learned that there can be an excess of pepper to some tastes, and they serve "con chile" or without it as desired, the fiery sauce being provided in a bowl instead of being poured over the eggs or meat before leaving the kitchen. This is a great deal better than the old way, for a stranger can learn to like the chilli a good deal better if he takes it in homœopathic doses, instead of burning his throat out in ignorance the first time of sitting down to a Mexican meal.

#### TABLES VOLANTES OR FLYING TABLES.

The inventors have a long way to travel before their tables can beat the magical appearance and disappearance of some tables I have seen in well managed hotels. Take this instance of preparation for a ball supper: There was but one room in the hotel large enough to dance in, and that was the dining room. It was also the only room in which to serve the supper. The question was how to use it for both purposes at once without an awkward break in the festivities, and as it was a grand ball, instead of a social hop, a "handed-round supper" would not do. There were two side rooms which opened into the dining room and also on the outside, and in these, without the least sign apparent to the guests, six long tables were set complete with flowers, lights, decorated pieces, salads, sweets, meats, ices, etc., everything except coffee. It was arranged with the musicians and the floor manager and at a certain time by the clock the company were led in a march to the further end, out of one door, through a bay-windowed conservatory and back into the dining room through another door, and as they

entered they saw, where they had been dancing but five minutes before, a brilliant set table nearly the whole length of the room. They said, of course, it was more like magic than common reality. If any of them had turned their head, like Lot's wife, while they were marching, they would have seen the tables following them, for at the same signal each of the six tables had been taken up by four waiting men and carried as it was to the place previously marked for it. When the supper was over the tables were carried out with like expedition.

## A QUOTATION MENU.

Private dinner at the Magnolia Hotel, St. Johns River, Florida:

## HUITRES.

"Lying with simple shells."  
Chateau Yquem. —*Pericles, act iii, scene.*  
"When the butt is out we will drink water; not a drop before.—*Tempest, act iii, scene ii.*

## POTAGE.

Tortue verte, claire.  
"A most delicate monster."  
Duke's Montillo. —*Tempest, act ii, scene iv.*  
"Give me a cup of sack."  
—*Henry IV, part i, act ii, scene iv.*

## HORS D'ŒUVRES.

Varies. Varies.  
Petits vols-au-vent, à la financière.  
"A mystery; aye, sir, a mystery."  
—*Measure for Measure, act iv, scene ii.*

## POISSON.

Pompano.  
"A royal fish; it shall be divided."  
—*i Black, Com., ccxvi.*  
"That sort was well fished for."  
—*Tempest, act ii, scene i.*

## Pommes de terre.

Concombres. Tomates.  
Rudesheimer.

## RELEVE.

Filet de bœuf, pique, aux truffes Perigord.  
"What say you to a piece of beef and mustard?"  
—*Taming of the Shrew, act iv, scene iii.*  
"The ox knoweth its owner and the ass his master's crib."—*Isaiah i, iii.*

Moët and Chandon's Cremant d'Ay.

"Come, thou monarch of the vine,  
Plumpy Bacchus, with pink eyne."  
—*Anthony and Cleopatra, act ii, scene vii.*

## ENTREMETS.

Points d'asperges au beurre.  
Petits pois, à la Française.  
Champignons, frais, au champagne.  
"To feed on flowers and weeds of glorious feature."  
—*Spencer: The Fate of the Butterfly, line 209.*  
Pâté de volaille en Bellevue.  
"For this, be sure, to-night thou shalt have cramps;  
Side-stitches that shall pen thy breath up."  
—*Tempest, act i, scene ii.*

Chateau Margaux.

"The next they brought up was a bottle of wine as red as blood."—*Buuyan's Pilgrim's Progress.*  
Mayonnaise de chevrette.

"This salad was born to do me good."  
*Henry VI, part ii, act iv.*

Tomates, farcis, à la duchesse.

"'Appetite comes with eating,' says Angeston."  
—*Rabelais.*

Grenadines de filet de chapon, à la Sultan.

"A feast of fat things."  
—*Isaiah, xxv, vi.*

Sorbet au fleur d'orange.

"What! must our mouths be cold?"  
*Tempest, act i, scene i.*

## ROTIS.

Bécasse. Bécassines, à l'Anglaise.

"What is the opinion of Pythagoras concerning wildfowl?"—*Twelfth Night, act iv, scene ii.*

"The peacock is an aga, but the little bird is a bulbul."—*Thackeray, Oriental Love Song.*

## SALADE.

"My salad days,  
When I was green in judgment."  
*Anthony and Cleopatra, act i, scene v.*  
Chambertin.

"We shall feast high with the blood of Burgundy."  
—*Scott, Quentin Durward.*

## SUCRES.

Omelette soufflé.  
Charlotte, à la Russe. Gelée au champagne.  
"A wilderness of sweets."  
—*Milton: Paradise Lost, book v, line 204.*  
"We are such stuff  
As dreams are made of."  
—*Tempest, act iv, scene i.*

Glacé Napolitaine.

"When it is baked with frost."  
—*Tempest, act i, scene ii.*

## FROMAGE.

"Copia pressi lactis."  
—*Vergilius, Ecl. i.*  
Roquefort. Stilton.

## OLIVES.

"Let us have peace!"—*Ulyses.*

## FRUITS ET DESSERT.

"Stay me with flagons; comfort me with apples."  
—*Song of Solomon, xi, v.*

## CAFE.

"Coffee, which makes the politician wise,  
And see through all things with his half-shut eyes."  
—*Pope, Rape of the Lock.*

Chartreuse.

"Good! yet remember whom thou hast abroad."  
—*Tempest, act i, scene i.*

Menu of the supper served at a great charity ball given at the Hôtel de Ville in aid of the poor of Paris. The feast was served by Messrs. Polet and Chabot, of the Rue Vivienne, at ten francs a head:

Consommé de volaille.  
Truite saumonée, sauce verte froide.  
Filet de bœuf glacée.  
Galantine de poularde truffée.  
Chaufroid de merles de Corse.  
Pâtés de foie gras de Strasbourg.  
Salade Venetienne.

Dessert.

Bordeaux. Médoc.

Partaken of by at least five thousand persons, more than a thousand being turned empty away.

# WHITEHEAD'S DICTIONARY OF DISHES.

## CULINARY TERMS AND VARIOUS INFORMATION PERTAINING TO THE STEWARD'S DEPARTMENT.

**ABALONE**—A shell fish cooked and served in Chinese restaurants in California. The shell is pearl of brilliant hues, largely employed in the decorative arts. The abalone trade of California has been recently estimated to amount to about \$250,000 a year. The flesh of these mollusks is preserved by drying and afterwards prepared for use by soaking in hot water; it is described as being tasteless and tough as India rubber when first put into the mouth, but soon breaks into granules with an agreeable flavor.

**ABATOIR** (Fr.)—Slaughter house.

**ABATIS** (Fr.)—Giblets. *Pate aux abatis* is giblet pie. **ABATIS DE DINDE A LA CHIPOLATA** is turkey giblets with sausages, etc.

**ABERDEEN SANDWICHES**—Hot sandwiches of fried bread in rounds like silver dollars, spread with minced chicken or other meats well seasoned.

**ABERNETHY BISCUIT**—A round, sweet cracker flavored with caraway seed. Common in English shops.

**ABSINTHE**—An intoxicating liquor, a common tipple in France, made of the extract of the weed wormwood and caraway seed in alcohol. Occasionally used in punches and fancy drinks.

**ACCOLADE** (Fr.)—Brace, pair; *accolade de perdreaux* is brace of partridges.

**ACCIDENTS**—Most frequently occurring in hotels are burns, scalds and cuts. Handles come off boilers of hot water or hot fat; frying vessels full of boiling lard tip over, steam rushes out from under a lid, or out of faucets instead of the water which has boiled away; red hot iron range lids and griddles are taken hold off by mistake, vats and tubs of boiling water are stumbled into or overturned. Wounds are received in cutting and chopping meat and in the breakage of crockery and glass. In the treatment of *burns or scalds*, the first object is to protect the injured part from the air. Pieces of lint or cotton, dipped in carron oil, will serve for this purpose. Carron oil (so called from being much used for burns at the Carron Iron Works, Scotland,) is a mixture of equal parts of linseed oil and lime water. When carron oil is not at hand, the burned or scalded part may be covered thickly with flour, olive oil, or vaseline. If some of the clothing sticks to the body, do

not try to tear it away; leave it alone and cut around the spot. In severe burns or scalds, the services of a surgeon should be secured as soon as possible. When the injury is slight, baking soda, applied either dry or wet, gives instant relief. For *scalds* from steam or water or for slight burns, dip the part in cold water and apply fine salt as much as will adhere. This will usually prevent a blister. **CUTS**—In case of a ruptured artery, the flow of blood may be checked by tying a twisted handkerchief, a cord, or strap, *between the wound and the body*. If the hand is cut, raise the arm above the head and bind it tightly. In *wounds of the throat, armpit, or groin*, caused by cuts, and in case of any deep wound, thrust the thumb and finger into the bottom of the wound and pinch up the part from which the blood comes, directing the pressure against the flow. If the cut is slight, let the blood flow for half a minute, then dip in cold water or apply ice. Draw the cut edges closely together with adhesive plaster, or by stitches and a bandage, and keep the part quiet. Slight cuts will usually heal quickly. In severe cuts, check the flow of blood and secure the attendance of a physician as soon as possible. *In cases of asphyxiation* by foul air, charcoal fumes, blowing out the gas, drowning, etc., artificial respiration should be induced. Loosen the clothing, or, better, remove it; rub the body with warm cloths; grasp the tongue with a towel and draw it forward; hold it there for a moment, then turn the patient on his face, with his forehead resting on one of his arms, and apply hartshorn or snuff to the nostrils; then turn the patient on his back, and dash first warm, then cold water in the face. If this fails, grasp the arms at the elbow and draw them slowly upwards above the head, keeping them there for two seconds; then turn down the arms and press them firmly against the ribs for two seconds, repeating these movements, carefully and perseveringly, about fifteen times in a minute, until respiration becomes natural; after this, apply cloths wet with hot water to the limbs and body, and cover with blankets. As soon as practicable give hot drinks. (For *poisoning* see *antidotes*.)

**ACETIC ACID**—Pastry cooks and confectioners use it in small quantities to whiten and stiffen cake icing, and to prevent granulation in boiling sugar.

## ACI

It is vinegar concentrated and refined and costs but little. Substitutes for it are lemon juice, cream tartar, tartaric acid and citric acid. Acetic, boracic and salicylic acids are all employed as dressings to preserve raw meats from spoiling when exported to great distances.

**ACID**—The harmless fruit acids used in cookery are those named above (see acetic acid), obtained from fruits of the citrus family, lemons, limes, etc., the lees of wine and from vinegar. Oxalic acid is poison though obtained from the weed oxalis or sorrel, which we cook and is harmless. Prussic acid is a poison although it is present in minute quantities and gives the pleasant bitter flavor to the leaves and fruit of trees of the almond tribe, which are freely used. An acid stirred into a solution of cochineal changes it from purple to scarlet, hence cake icing and other substances colored with cochineal have a brighter tint if they are slightly acidulated. Lemon juice or other acids stirred into such mixtures as boiling pudding sauce, tapioca or starch jelly and some soups, generally will change their bluish appearance to clear transparency. Lemon juice or other acid is often required to make a similar change in gelatine jelly and in strong consommés, which sometimes become too rich and viscid to pass through the strainer until cut with a dash of acid. Acids act upon copper or brass so as to brighten the surfaces. Acid and salt will clean a copper or brass vessel, the brightened surface soon tarnishes, however, unless dry polished afterwards. Acids act upon copper and brass vessels in such a way as to produce a poison called verdigris, which forms at the edge where the air, acid and copper are in contact. Stewed fruit, cranberries, pickles, slaw, salads, etc., acquire a bitter taste and become poisonous if left standing a few hours in copper or brass, and brass spoons from which the plating is worn off become coated with a bitter tasting poison if left in dishes of fruit jelly, sauce, pickles, salads, or anything that contains an acid. Acids act on iron in such a way that sour bread dough set to rise in iron pans becomes stained as with ink. They act on tin and zinc to a less degree, but salads containing vinegar acquire an unpleasant metallic taste in tin pans, and should be made and kept in glass or earthenware bowls. Acids, like lemon slices or juice or vinegar, will whiten boiling chickens, fish, turkeys, calf's head, sweetbreads, etc., provided the vessel used to boil in be bright and new, but if an iron vessel or a tin one much worn, the action of the acid will often spoil the appearance of the fish or meat entirely by turning them blue and of a dirty color, and when such vessels with the tinning mostly worn off must be used, the vinegar or lemon juice should be omitted. (See boracic acid.) Acids dissolve sea shells and egg shells immersed in them; their action upon the lime of the shells produces a slow effervescence until the lime is all driven off. In like manner lemon juice injures the finger nails, making them brittle and jagged. A very slight

## ADE

acidity or sourness is generally productive of whiteness in bread and cake, while the opposite alkalinity produces a yellow or dusk color, thus bread just on the point of turning sour is the whiter, and bread made with milk turns out whiter through the formation of lactic acid or the souring of the milk in it while rising, but the addition of soda to counteract the slight sourness would make it a darker shade. In cake-making the addition of lemon juice or cream tartar alone produces both lightness and whiteness, while soda or baking powder added has the effect to make the hue either dull yellow or grey.

**ACID AND SODA**—The original baking powder or yeast powder, mixed and used by cooks and bakers before prepared baking powders became a regular article of manufacture and sale. (See baking powder.)

**ACID AND ALKALI**—Acids mixed with such alkalies as soda, saleratus, potash, marble dust and lime, when wetted, begin to change into gas which rises into the atmosphere and is lost, but if the change takes place within a lump of dough that becomes light with innumerable bubbles of the gas, which expanding still more with the heat in baking make a light and spongy loaf. Soda fountains are charged by placing marble dust, which is one form of lime, in the generator, pouring dilute sulphuric acid upon it and immediately screwing down the lid. The acid and lime change into gas which can only escape through a pipe into another tight vessel nearly filled with water, where it remains imprisoned until drawn from the soda fountain. Whether in bread or in a soda fountain, if the acid and alkali are not properly matched in quantity, a portion of either one or the other will remain behind unused and unchanged in the bread or in the generator. When they are rightly proportioned they still do not all go off in the gas, but leave a remainder, a new compound called a salt, which may be only common salt or may be something hurtful, according to the kinds of acids and alkalis employed. According to one of the stories from history, Cleopatra owned the largest and most valuable pearl in the world of her day, and dissolved it in a cup of vinegar and drank it. Strong vinegar would dissolve the pearl, considerable time being allowed, nitric acid would have consumed it in a few minutes, yet Cleopatra did not drink the pearl; it passed off in the form of gas. If she drank during the effervescence she drank a sort of soda water. If the pearl and vinegar were just sufficient to neutralize each other, when the pearl disappeared the vinegar had lost its sourness and Cleopatra drank only water containing a nearly tasteless tartrate.

**ACID ICING**—Meringue or frosting made with lemon juice in equal quantity with white of eggs.

**ACIDULATED PUDDING** — Sponge cake slices, saturated with lemon syrup and covered with custard in a dish.

**ADELAIDE SANDWICHES**—Hot rounds of

## ADM

fried bread with minced chicken, etc., between, like Aberdeen sandwiches, with a small ball of cheese baked upon top of each just before serving.

**ADMIRAL PUDDING**—A boiled suet plum pudding, made with mashed potatoes and carrots each in equal proportion to the flour.

**ADMIRAL SAUCE** — Anchovy sauce with chopped capers and shallots added, and very little lemon rind; in other words, butter sauce with pounded anchovies, shallots, capers and little lemon rind in it; good for boiled fish.

**ADAM'S APPLE**—The banana; supposed by some to be the fruit of which Adam ate.

**AERATED BREAD**—Bread charged with gas the same as generated in soda fountains. The loaves are inclosed in a tight mould, gas forced into them, and baked. In baking, the gas expanding makes the bread light. The effect is similar to mixing acid and soda in the flour, but there is no residue of salts left in the bread by this method, and there is no loss of the flour as in fermentation, which process changes part of the flour to a gas which raises the bread. Companies with large capital are carrying on the aerated bread business in several cities. "The method of Dr. Daughlish, the results of which are now made so well known by the catering energy of the Aerated Bread Company, depends upon the fact that water may be made to hold within itself a large quantity of liquid carbonic acid under pressure, which it liberates as gas when the pressure is removed or diminished, as shown by soda water and other aerated liquids. The flour, with as much salt as is required, is placed in a strong air-tight vessel. In another strong vessel is water highly charged with carbonic acid under pressure, like soda water in bottle. The two vessels communicate by a pipe with tap; that containing the flour has a kneading apparatus working through an air-tight stuffing-box. On opening the tap the aerated water is forced into the kneading vessel in due quantity, and the flour is then worked into paste or dough while still under pressure. On removing the pressure the carbonic acid expands, as it does in uncorking a soda water or champagne bottle; but instead of escaping freely, as in these cases, it expands the dough. By a simple arrangement of a suitable outlet, the dough may be squirted out by the pressure of the gas within, and thus run into the form of a long cylinder of required thickness for cutting up into loaves, which must be baked without loss of time, as they would otherwise collapse."

**AERATED DRINKS**—Bottled soda, ginger ale, etc., are flavored waters charged with gas by means of a forced apparatus made for the purpose.

**AERATED WATERS**—A few natural mineral waters are slightly aerated, discharging air bubbles as they rise in the spring. Some of these and others, found suitable, are artificially charged.

**AERATED WINES**—Imitation wines and cham-

## ALA

pagnes are made effervescent as if fermented by being charged with gas like aerated drinks.

**AGARIC**—Mushroom, (botanical name), also the name recently adopted for a bottled liquor or bitters designed to fill a long felt want in prohibition communities. There are hundreds of species of agaric or mushroom, and one kind, *amanita muscaria*, produces intoxication and is eaten or rather taken in doses by people in some parts of the world for that purpose.

**AGNEAU** (Fr.)—Lamb; *selle d'agneau* is saddle of lamb; *quartier d'agneau* is quarter of lamb.

**AGNEW PUDDING**—English name for an apple cream pie.

**AIGLE DE MER**—French name of the hornfish.

**AIGRETTES AU PARMESAN**—Cheese puff fritters, or *beignets soufflés*, with grated Parmesan cheese mixed in the batter.

**AILERONS** (Fr.)—Pinions; *ailerons de dinde* is turkey wings; *ails de poulets*, chicken wings.

**AITCHBONE** or **EDGEBONE**—The cut of beef in the hindquarter at the end of the loin, between that and the rump. The meat lies in detached layers with skin and gristle between; inconvenient to cut into steaks; it makes a second rate or help's roast and is good to salt and boil.

**ALASKA TROUT** (*salmo purpuratus*)—A variety different from the Atlantic trout in its markings, being spotted with black spots of the size of buckshot.

**A LA MODE BEEF SOUP**—An English soup in which the meat is stewed to pieces and served with it, brown and thick.

**A LA MODE BEEF SHOPS**—"Upon entering the à la mode beef refectory, an astonishing sight met my view. The patrons were all seated, but how? Little benches, scarcely more than a yard long, accommodated each of them two customers. In front of them was a little table a foot and a half wide, and this was shared by the people on the bench opposite. In fact, on every square yard and a half, or thereabouts, four people were eating, the food being brought to them at call by the waiters. At one end of the long room, which must have held more than three score eaters, was a man who ladled out of the huge cauldron the thick soup and stewed beef known as à la mode, and passed it on to the waiters, who flicked it to their customers. It was evidently the staple dish of the establishment and was very savoury. It had the odour—a strong one, certainly—of a wholesome but highly flavored mess, and I am bound to say that those who were devouring it seemed satisfied."

**A LA MODE BEEF**—An English dish not to be confounded with the *boeuf à la mode* of the French. Take eight or ten pounds of beef (the rump or buttock) or the same weight of a breast of veal. Divide into neat pieces of three or four ounces in weight,

## ALB

Put it into a large stewpan with four ounces of good beef dripping; but first make the dripping hot, and flour the meat. Add a couple of large onions, minced very fine, dredge flour, and stir with a wooden spoon for about ten minutes, or until the contents of the pan be thick; then pour in about one gallon of water. Do this gradually, stirring all together. Bring it to a boil; then skim, and add one drachm of ground black pepper, two of allspice, and two bay-leaves. Set the pan where it will stew gently for about three hours. When the meat is tender, serve.

**ALBANY CAKES**—The same batter as for "popovers," baked in shallow pans to make a thin muffin. Hot for breakfast.

**ALBEMARLE PUDDING**—Sugar, eggs and pounded almonds in equal weights beaten together to a froth and baked in a tin.

**ALBUMEN**—White of egg is albumen in its purest form. It is abundant in the flesh of chickens, rabbits, fish, and is a constituent of all sorts of meat in a greater or less degree. When chicken meat or chopped beef is set over the fire in cold water, the water becomes milky while heating through the albumen flowing out of the meat. When boiling heat is reached, the milky appearance is changed to perfect clearness of the water, and the albumen has risen to the surface in the form of scum. If the chicken had been dropped into boiling water, the albumen and other juices would not have flowed from the meat, but remained within it. This is why a leg of mutton or other fresh joint should be set on to cook in boiling water, that the gravy may be kept in the meat until it is cut; the albumen of the outside cooks instantly and keeps in the juices. But to make soup or stews the meat should be put on in cold water. Albumen is used in immense quantities in manufactures, especially in calico printing. The demand for albumen has led almost to the extermination of the immense flocks of wild birds, such as snipe, plover, curlew, widgeon and various species of ducks which breed on the islands of the northern sea and formerly swarmed at certain seasons along our coasts, for their eggs have been gathered by the vessel load year after year, until there was no longer a harvest left to gather, unless new breeding places could be discovered. A new source of supply of albumen has now sprung up; the blood from the large slaughter houses is contracted for by firms that makes a business of extracting the albumen from it for use in the arts, and convert the remainder of the blood into fertilizers. (*See article on eggs.*)

**ALBERT CAKE**—Is sponge cake with finely chopped almonds and candied orange peel and a little ground spice mixed in.

**ALBERT BISCUITS**—Same as the above, baked in small moulds like small sponge cakes or savoy.

**ALBERT PUDDING**—Steamed pound pudding with raisins in it. The mould it is steamed in is but-

## ALK

tered and lined with strips and stars of citron and figs. Brandy sauce.

**ALCOHOL**—Much employed formerly to burn in lamps under chafing dishes, but made too dear for general use by the revenue tax. It is in use still by persons who take pleasure in preparing special dishes over the flame of a lamp at their own table. Alcohol is the medium employed to unite with the essential oils of fruits to make flavoring extracts; extract of lemon, orange, vanilla, etc., are made by mixing oil of lemon with alcohol or steeping the vanilla bean in it. Sticks of cinnamon, broken nutmegs, bruised ginger, cloves, peach kernels, blades of mace and various other flavoring substances may be used to make ordinary extracts for cooks and bakers by putting them to steep in bottles of alcohol, which may be drawn off into other bottles when strong enough and refilled. It is alcohol that burns when fire is set to brandy or rum for omelets or pudding sauces, and when the spirit used will not burn, a little alcohol added to it cures the difficulty. Alcohol is useful to remove grease stains, and to clean silver, glass, mirrors, etc. Rose flavoring and other flower flavors, such as orange flower, may be made by steeping the flower leaves solid packed in a jar of sweet oil for several days, pressing out the oil and mixing it with alcohol, then distilling the alcohol which carries the flower flavor with it into another vessel.

**ALDERMAN'S PUDDING**—Sort of custard pie or cheese-cake, with currants, raisins, suet, grated rind, bread crumbs and eggs in three pints of milk.

**ALE POSSET**—A hot drink; an old English form of egg-nogg, made by pouring a pint of boiling ale to a dozen beaten eggs with sugar, nutmeg and, sometimes, a glass of brandy. Served with toast.

**ALEWIFE**—An American fish of the herring family, smaller than a shad.

**ALEXANDRA PUDDING**—A boiled bread custard with fruit in it, made by filling a mould or basin with bread crumbs, having currants and raisins mixed in, and pouring in eggs mixed with cream or milk in custard proportions, sweetened and flavored; boiled 2 hours, tied down with a floured cloth. Cherry jam or dilute preserves for same.

**ALKANET ROOT**—Used about furniture by the repairers; it makes a red stain for wood.

**ALKALIES**—Soda, saleratus, potash, borax, lye, ammonia, quinine, morphine, are some of the alkalies; they neutralize acids by combining with them in the form of gas and salts, hence act as antidotes to acid poisons; they combine with oils and fats in the form of soap; they change a red solution of cochineal to blue; added to the water in which green vegetables are boiled, they keep them green where otherwise the vegetables would be almost black, but if in excess they change the green to yellow and dissolve the leaves and stems. They help to restore



## ALL

tainted meat by counteracting that part of the taint which is only sourness caused by hot packing and keeping in bulk.

ALLEMANDE (*a l'*)—German style.

ALLEMAND SAUCE—A yellow or cream-colored sauce made of broth seasoned with mushroom liquor, parsley and onion, thickened with white roux and yolks of eggs, and little lemon juice to finish. Good for fish, chicken, etc.

ALLSPICE—Pimento, a common spice useful in mincemeat and common brown cakes and puddings, when ground, and in the whole state is used in pickling, in pig's feet, tripe, sweet pickles, etc. The cook needs a small quantity ready in the spice box to add to some kinds of soup, and game entrees, the pastry cook uses a small amount, whole, to boil in gelatine jelly.

ALLIGATOR STEAK—Slices cut from the fleshy tail of young alligators are sometimes cooked and tasted, if not eaten, from motives of curiosity, by Southern tourists. The meat is somewhat like boiled beef, is not objectionable in taste, but is sinewy and tough and seldom provokes a second trial. An English traveler in South America found that young alligators were regularly sought after to be used for food, and he partook of some, stewed, which he compared to the favorite flatfish sole in taste.

ALLIGATOR EGGS—Are eatable and sometimes displayed for sale in Florida markets. They are esteemed by the natives of the West Indies, and so are crocodile's eggs in the East.

ALLIGATOR APPLE—Name of the custard apple of the West Indies. Eaten raw. It is called the coster in the British West Indies, and being formerly sold by peddlers in London caused them to be called costermongers, a name now applied to all small peddlers of marketings.

ALLIGATOR PEAR—A fruit of the West Indies. Is common also in Mexico where it is called the *avocado* (advocate). It is eaten raw in the same ways as muskmelons, usually with salt and pepper, and is sliced up in salad with oil and other dressings.

ALLUMETTES D'ANCHOIS (Fr.)—Strips of anchovies wrapped in paste and fried.

ALMOND—The nut is the seed of a fruit of the peach kind. There are several varieties; the bitter almond is one of them; it is used sparingly to add flavor to the sweet almonds in various preparations. A substitute for bitter almonds is peach kernels. The hard-shell almonds have a higher flavor than the soft-shells, and are to be preferred for cooking purposes. ALMOND PASTE—The ready-prepared almond paste can be used in nearly all recipes where the directions are to blanch and pound the almonds in a mortar, a proceeding which consumes much time; the paste is about one-half almonds and one-half sugar. It is sold at confectionery supply stores in five and ten pound tins at about twenty-five cents

## ALM

per pound on the average. To use it, shave slices as thin as possible and roll and crumble the shavings into the sugar which is to be used to make the cakes, etc.; for liquid uses, pound the shavings in a mortar, with sugar and milk, till thoroughly divided.

ALMOND CAKES—*No. 1*—Half pound each almonds (or paste), sugar and flour,  $\frac{1}{4}$  pound butter, 8 eggs; mixed like pound cake. *No. 2*—Half pound almond paste, 4 eggs, 1 ounce butter,  $\frac{1}{4}$  pound flour; butter and yolks worked with the almond paste, whites whipped, and flour last. *No. 3*—Any white cake, silver cake, starch cake, etc., made with a proportion of almonds or paste, becomes almond cake. (*See Albert cake.*) ALMOND ROLLS—Almond paste with yolks of eggs enough to make it into a dough that can be worked into fancy patterns and shapes, glazed with gum arabic and ornamented, dried, then carefully baked. ALMOND DARIOLES—

Pastry cream or frangipane, same as used to fill cream puffs, with almonds, almond paste or extract in it; bake in paste-lined patty pans. ALMOND

NOUGAT—Made same as common peanut candy, with a pound of blanched and parched almonds in half pound of sugar melted, light brown. ALMOND

ICING (yellow)—Made with a pound of sugar, half pound pounded almonds and yolks of eggs to make paste, or with almond paste, sugar and yolks; spread over cakes before the white icing. ALMOND ICING

(white)—Ordinary white icing, with chopped almonds or almond paste mixed in to spread on cakes for a first coat, and smooth icing afterwards.

GATEAU DE AMANDES A LA PARISIENNE—Almond cream pie made by mixing almond paste in pastry cream or frangipane. (*See almond darioles and cream pies.*) These, however, are baked on jelly

cake pans instead of pie plates. ALMOND CUP CUSTARDS or ALMOND CREAMS—Boiled custard, with almond paste added, served in custard cups with whipped whites on top. ALMOND MACAROONS

(hard)—*No. 1*—Almond paste or pounded almonds mixed with pound cake or other cake batter, small lumps baked on pans or paper. *No. 2*—Two-thirds

sugar, one-third almond paste or crushed or minced almonds, white of egg to wet it into dough; small lumps baked on pans or paper; slack oven. ALMOND

MACAROONS (soft)—Light, hollow; made with a pound of sugar, one ounce corn starch, half pound

crushed almonds, three whites, beaten light, baked slack on sheets of paper, taken off paper by brushing bottom with water. ALMOND FINGERS—Cake

icing with almond paste mixed in, run on pans like lady-fingers; slack bake. ALMOND CREAM PIE—

Pastry cream made of milk, sugar, flour, eggs and crushed almonds or paste, baked in a thin crust of puff paste. ALMOND NOUGAT CAKE—White almond

candy in a shape, made of one pound sugar, two pounds shred almonds, dried and warm, and a table-spoon of vinegar to dissolve the sugar over fire; almonds mixed in after sugar melts; flattened on slab

and pressed into mould like a lining; can be filled with cream. ALMOND CHEESE CAKES—Almond

## ALM

cream pies made in small patty pans; same mixture may have whipped whites of eggs stirred in or on top. ALMOND CROQUANTES—Nearly same as rout cakes; made by moistening almond paste with yolks of eggs, or pounding almonds and sugar and yolks together; rolling out in sugar, cutting shapes, baking, then dipping in boiling sugar, and drying. ALMOND CUSTARD—Custard either baked or boiled, flavored with almonds or almond extract. ALMOND CREAM ICE—English for almond ice cream. ALMOND ICE CREAM—Any ice cream or frozen custard having almond paste mixed in. BISQUE OF ALMONDS—Almond ice cream in moulds. ALMOND CHOCOLATE—Bleached almonds dipped in hot chocolate icing and dried on paper. ALMOND BLANC MANGE—Blanc mange or Bavarian cream with almonds or paste in it. ALMOND FRITTERS—Same as cream fritters or fried cream made with corn starch, with almond paste in it, cut like cold pudding in pieces, breaded and fried. ALMOND JUMBLES—Same as hard macarons rolled out like cookies. ALMOND MERINGUES—Same as egg kisses or meringues a la cream, with shred almonds and granulated sugar dredged on before baking—may be filled two together with almond cream or served plain. ALMOND OMELET—An ordinary omelet with almond paste crumbled in sugar strewed on it and rolled up in it, more on top, and glazed with hot iron. SALTED ALMONDS—Almonds blanched, sprinkled with salt and a little cayenne, fried in butter till a rich gold color, drained on paper; served cold with salt. DEVILLED ALMONDS—English name for salted almonds. ALMOND PUDDING—No. 1—Made of fine bread crumbs and almond paste mixed in, like bread custard pudding. No. 2—A steamed batter pudding with bread crumbs, almond paste and whipped whites in the batter, in moulds or cups. No. 3—A white cake mixture with raisins and almond paste in it; steamed. ALMOND CROQUETTES—Almond paste and sponge cake crumbs moistened with sweet wine and white of egg, made into croquette shapes, breaded and fried. ALMOND SOUP—No. 1—Any cream soup may have a puree of almonds added for flavor and the name. No. 2—A milk soup made without meat, but with a paste of pounded almonds and also shredded almonds in it. No. 3—The original *potage a la reine* is said to have been a cream of chicken and almonds. ALMOND HEDGEHOG—Made with almond paste, eggs, flour, butter, cream and flavoring stirred over fire until stiff enough to form in the shape of a hedgehog on dish—a sort of rich hasty pudding, in effect, or pastry cream made, stiffer—stuck full of split almonds to represent spines; served with sauce like pudding. ALMOND LAYER CAKE—Almond paste stirred into boiling syrup, yolk of eggs to thicken it, spread between layers of thin cakes, or rolled like jelly roll; can be made white instead of yellow by using whites to thicken. ALMOND PASTE ADULTERATION—It is charged against the manufacturers by the analysts that the almonds are first deprived

## ALU

of their oil, which is a separate article of commerce, and are then flavored with prussic acid.

ALOSE (Fr.)—Shad.

ALOUETTE (Fr.)—Lark. *Alouettes a la minute*, a hasty dish of larks, French restaurant specialty prepared as follows: Sauter in butter twelve larks (cleaned and plucked, of course). Withdraw as soon as the butter has colored them. Brown in the same butter two or three minced shallots, a pinch of parsley, and twenty mushrooms sliced. As soon as the mushrooms are cooked, add a spoonful of flour, and moisten with a glassful of white wine and a small cupful of bouillon. Allow the larks to stew for some minutes in this sauce. Brown in butter croûtons of bread, as many as there are birds. Serve each lark on a croûton and pour over the dish the mushroom sauce. Other small birds may be prepared in the same way. (See *Mauviettes*.)

ALOYAU (Fr.)—Sirloin of beef.

ALPHABET PASTES—For soup; the same paste as macaroni and spaghetti, but stamped into very small letters or ornamental shapes which swell in boiling. Can be bought in packages, one pound or less. Not expensive.

ALUM—In a powdered state has been extensively employed as an adulterant in bread; it has much the same effect as a slight tendency to sourness in the dough has in whitening the bread; it has some effect in preventing certain constituents in flour from changing into a gummy and transparent appearance, which makes the bread look dark. Bakers find that second-rate and soft flour is corrected by the use of alum, so that it produces a more saleable loaf than better flour would without such treatment. Alum is, however, unwholesome, while not positively poisonous; it is a mineral salt, which, regularly taken into the stomach, causes great injury to health; the bread adulterated with it is damaged also in its keeping qualities, and becomes unduly dry and tasteless in a day after baking. Stringent laws have been passed in various countries to suppress this practice; in Paris as many as forty bakers at one time have been fined, their shops closed and their business suspended by law, as a punishment for using alum in bread; prosecutions, convictions, fines and imprisonment have occurred in most large cities of the United States for the same cause. The bakers' journals deny now that this practice prevails to any considerable extent, and a state of opinion has been worked up in the trade which causes it to be considered disgraceful and dishonest to resort to the practice. The adulteration of bread with alum seems to be on the decrease. In hotel bakeries there is no need of resorting to such expedients. Alum is one of the injurious ingredients in inferior baking powders. It is useful in pickling, to make the pickles firm and brittle; it is used in making cochineal coloring, in very small amounts, and dyeing, etc., to set the colors. Plain alum, and its derivative, the bisulphate of alumina, have a remark-

## AMA

able effect in clarifying muddy water, and the former is extensively employed for that purpose. A small quantity—a tablespoonful powdered—mixed with a barrel of Mississippi river water renders it quite clear after standing an hour or two, and the impurities are coagulated together by its action so that they can be removed by straining. The immense filtering works which now operate to purify the entire water supply of some cities are based upon this singular property of the mineral salt alum. Powdered alum is useful in case of a cut to apply to stop the flow of blood.

AMANDES (Fr.)—Almonds.

AMANDES PRALINEES (Fr.)—Burnt almonds; parched and sugared almonds.

AMBROSIA—Literally food for the gods; a bowl of sliced oranges and pineapples, grated cocoanut, sugar and wine.

AMBER CLEAR SOUP—A name for clear soup, *bouillon* or *consomme*.

AMBER JELLY—A name for gelatine jelly when of an amber or golden color. Amber is a substance like jellow glass or rosin, found on the sea coasts, used for mouth-pieces in pipes, and in jewelry.

AMBER PUDDING—A boiled or steamed lemon bread pudding.

AMBERGRIS—Literal meaning *grey amber*, used by the liquorists to flavor cordials, bitters, etc.; highly valued in perfumery. It is a substance of the consistency of wax, found in sperm whales; also found floating in masses, weighing one or two hundred pounds in the Indian Ocean. Ambergris flavor is said to be a favorite with the Prince of Wales, and confectioners and caterers use it the more on that account. AMBERGRIS ESSENCE—Made of an ounce of ambergris steeped in a quart of proof spirit in a warm place for a month, the mixture is then filtered. Two or three drops will flavor a quart. AMBERGRIS CREAM—A whipped cream stiffened with gelatine (Bavarian cream), flavored with ambergris essence and colored yellow, set in a mould on ice. AMBERGRIS JELLY—Gelatine or calf's-foot-jelly, flavored with ambergris.

AMONTILLADO—Name of a popular brand of sherry, served with fish.

AMMONIA—Hartshorn; *sal volatile*; *volatile alkali*; smelling salts. Carbonate of ammonia is used by bakers to raise cakes; it is much stronger and more effective for the purpose than baking powders. The quantity used is about the same weight for weight as baking powder; the cost, in an average way, is about the same. The ammonia changes to vapor in the oven and expands the dough it is mixed with. The method of using is to crush the lumps to a white powder and dissolve it in the liquid that makes the dough. Ammonia is but little used in hotels, the odor from the baking being objectionable. A proportion of ammonia mixed with baking

## ANC

powder makes it stronger as long as it is kept tightly closed in glass jars. Liquid ammonia is one of the most serviceable alkalies for cleaning silver and removing grease stains. A small lump of ammonia dropped into the water with peas or asparagus or other green vegetables, will keep them green while boiling.

AMOURETTES DE VEAU (Fr.)—Tendons of veal; the gristly part of the breast; the edge of the brisket stewed tender.

ANANAS (Fr.)—Pineapple.

ANCHOIS (Fr.)—Anchovy.

ANCHOVY—A little sea fish caught in the Mediterranean. It has a high flavor, is used as an appetizer and in sauces. It is preserved in salt brine; can be bought either in bottles or small kegs of one or two quarts' size. Anchovies as a cold *hors d'œuvre* are served uncooked. Wipe, split, serve in oil like sardines with garnish of eggs, parsley, lemons, etc., and, uncooked, they are cut in pieces in some sorts of salads. ANCHOVY ESSENCE is a pink-colored, oily, thick sort of sauce; can be bought in bottles. One London firm is said to have almost a monopoly of the manufacture, making nine-tenths of all the anchovy essence used in the world. The essence consists of pounded anchovies simmered with water, vinegar, spices, mushroom catsup and the brine the fish were preserved in, all passed through a seive, bottled and corked down while hot. Adulterated or spurious samples have been found to contain starch for consistency and Venetian red for color. Anchovy essence is used to flavor fish sauce, (*see admiral sauce* or *sauce a l'amiral*), and as a finish to turtle soup, and especially for imitations or soups made of fresh water turtles. The largest sea turtles possess the anchovy flavor so strong as to make them scarcely eatable. ANCHOVY PASTE—Another name for anchovy butter. ANCHOVY BUTTER—Anchovies washed, boned, pounded with soft butter through a seive; may be mixed with parsley and lemon juice; is used to spread upon hot, broiled beefsteak and upon toast, also in pats to garnish dishes of broiled or boiled fish. It can be made as well by stirring anchovy essence into softened butter. ANCHOVY POWDER—Anchovies passed through a seive, made into a paste with flour, baked dry in thin cakes, powdered and used for flavoring. FRIED ANCHOVIES—Split, boned, dipped in fritter batter and fried same as *anchois a la d'Horly*. ANCHOVY SAUCE—Butter sauce, hot, highly flavored either with anchovy essence or chopped anchovies and lemon juice; served with fish and steaks. ANCHOVY OMELET—Fillets (boneless sides) of anchovies laid on an omelet, not rolled but flat in the pan, another flat omelet turned upon it and the cooking of the inside finished in the oven. ANCHOVY TOAST—Slices of toast, either buttered and with the boneless sides of anchovies with mustard and cayenne laid upon them, or toast spread with anchovy butter. ANCHOVY PATTIES—Small pieces of fish forcemeat

## ANC

mixed with anchovy butter baked inside of two flats of puff paste. **ANCHOVY TARTINES**—Round and thin slices of bread or biscuits, buttered, anchovies in oil (like sardines) cut in thin strips and arranged crosswise upon them, the spaces filled with minced eggs, pickles, etc.; lunch dish. **ANCHOVY SANDWICH**—Thin sliced bread spread with anchovy butter or purée of anchovies with butter. **ANCHOVY EGGS**—Hard boiled eggs cut in halves, the yolks taken out, rubbed through a sieve, seasoned with anchovy essence and butter, put back in the whites served, garnished, either hot or cold. **ANCHOVY BREAKFAST CAKE**—Rice (boiled) stirred up with anchovy essence, butter, flour and eggs, and baked. **ALLUMETTES D'ANCHOIS**—(See page 231.)

**ANCHOVY PEAR**—A fruit of the West Indies.

**ANCIENNE** (*a l'*)—Ancient style; in the old-fashioned way.

**ANDALOUSE** (*a l'*)—In Andalusian or Spanish style. **ANDALUSIAN SOUP**—A brown beef soup with purée of tomatoes added, and slight flavor of garlic.

**ANDOUILLES** (Fr.)—Chitterlings.

**ANDOUILLETES** (Fr.)—Small sausages.

**ANDOUILLETES AUX HUITRES** (Fr.)—Oyster sausages. (See oysters.)

**ANDOUILLETES DE TROYES GRILLEES**—Vcal sausages broiled; a specialty of the great London grill rooms.

**ANGELS ON HORSEBACK**—English foolish name for oysters wrapped in bacon and broiled.

**ANGEL FOOD**—A fanciful name found in many cook books, applied to some light dessert, usually of whipped cream; also to a white sponge cake.

**ANGEL CAKE**—Fanciful name of the whitest and lightest of all cakes; a white sponge cake of recent invention, made of one pound sugar, one pound whites, half pound flour, one ounce cream tartar, and some flavoring.

**ANGEL FISH**—A sea fish of the shark family, eatable, but not desirable; named so by sailors on account of its broad, wing-like fins.

**ANGELICA**—A plant, the stalks of which are preserved like citron or watermelon rind. It is valued for its green color for decorative purposes in confectionery; often mentioned in Old World confectionery books, but seldom met with and scarcely obtainable in this country; old-fashioned or obsolete.

**ANGELICA WINE**—A California sweet wine made from angelica grapes; useful for frozen punches, pudding, sauces, wine jelly, etc., and not expensive.

**ANGLAISE** (*a l'*)—In English style.

**ANGUILLES** (Fr.)—Eels.

**ANILINE**—The brightest coloring for confectionery. The red shades from pink to purple are perfectly harmless, and if they were not the quan-

## ANT

tity required to color is so extremely small that no injury could ensue. The greens and yellows in aniline colors are all more or less poisonous and cannot be admitted to the pastry or confectionery room. Aniline is one of the many products of petroleum. Some years ago, when petroleum and the substances obtained from it were new and but little understood, a French chemist undertook to ascertain the effects of aniline upon the human system by taking doses of it himself, increasing the quantity daily, and came to these conclusions, viz.: Aniline, pure, has no effect, either good or bad. The chemicals used to make aniline red are perfectly harmless. The chemicals used to make aniline green, blue and yellow, are arsenic and other injurious substances. Consequently the reds may be safely used, but not any other colors. The quantity needed is scarcely more than five cents' worth for six months; the dip of a cork will color a gallon; buy dry aniline and dissolve in warm water.

**ANISEED**—A small seed used for flavoring, nearly resembling caraway and celery seed; used by bakers and liquorists. **ANISETTE**—A liquor like absinthic and kummel, made from aniseed in spirits. Used sometimes for flavoring punches and sherbets. **ANISEED OR ANISETTE RUSKS**—Sponge cake or other kinds flavored with a spoonful of aniseed, baked, sliced, then dried in the oven. **ANISETTE SLICES**—Slices of cake freshly cut from a cake of Scotch shortbread, which has been flavored by having aniseed mixed in. Aniseed is sometimes mixed with rye-bread and various sorts of cakes by German bakers. Its price is unsettled, but is usually about 80 cents per pound at retail.

**ANNA POTATOES OR POMMES A L'ANNA**—Said to have originated at Delmonico's. Potatoes pared and sliced raw; replaced with butter between each slice and baked until done. Rich and expensive on account of the large quantity of very best butter required.

**ANNATTO**—Butter color. It is used to color butterine and other spurious butters, and is used in the creameries to give the uniform color to the best butter as well. The natural yellow of pure grass butter is different from annatto color in that the natural is at the deepest only the bright yellow of the sunflower, annatto makes an orange color. Mixed lots of butter from country stores, no two samples being alike, are sometimes worked over with annatto to make marketable as creamery butter. Annatto is a gummy substance, something like wax, of a dull red color in its dry state. Obtained from the fruit of a tree that grows in the tropics. Is often called Spanish annatto. Costs about fifty cents a pound. It cannot be dissolved perfectly in water; dissolves partially in milk, in cream, and most thoroughly in warm oil or melted butter.

**ANTELOPE**—The antelope of the western plains, being the fleetest of foot and most numerous, survives the buffalo, mountain sheep and black-tail

## ANT

deer and still constitutes a very considerable portion of the game supply of the cities. Antelope meat is not as highly esteemed as venison, but may easily be mistaken for it in the market. Only the hind quarters are shipped in and they are usually wrapped in the skin of the fore-quarter, in addition to their being unskinned. The hair is very loose, coming out by the handfuls and proves very troublesome to remove from the meat if once brought in contact. Antelope is the tenderest or softest of all meat; young animals are excellent eating; the flesh of the older ones is as dark as calf's liver and is apt to have a musky taste, which, if not really objectionable to those who like game, still serves to distinguish it from deer meat and prevents its substitution. Cranberry or currant jelly is the best sauce. ANTELOPE STEAKS—Are slices cut from the leg; should be cut thick and slightly flattened. ANTELOPE CUTLETS—The loin cut into chops. SADDLE OF ANTELOPE—The two loins undivided. HAUNCH OF ANTELOPE—The two loins and legs undivided, but shortened by removing the inferior part of the legs. The fore-quarters of antelope are not unfit to eat, the rib chops and shoulders being good, but are thought too light to pay for shipping. To COOK ANTELOPE—Besides the hunters' ways of broiling, frying and stewing, and the specially American method of baking and serving with cranberry sauce, antelope may be advantageously cooked and sauced in any of the ways prescribed for venison, roebuck, and the like; young antelope is specially good larded with fat pork and cooked like filleted rabbits.

ANTIDOTES—Any substances which counteract the effects of poisons. When poison has been swallowed, first and instantly dilute the poison with large draughts of warm water, either clear, or, if the particular poison is known, containing the proper antidote. Excite vomiting. Protect as much as possible the lining of the stomach from contact with the poison by large and frequent doses of sweet oil, mucilage of gum arabic, flaxseed tea, milk, melted lard or butter. *A general antidote*, where the name of the poison is unknown, is a mixture of carbonate of magnesia, powdered charcoal, and hydrated sesquioxide of iron, equal parts in water. *Mineral acid poisons* are counteracted by powdered chalk, whiting, magnesia, or lime scraped from a wall and stirred in water. Also by soap suds, sweet milk, soda or saleratus, all in very small doses at first. In case of oil of vitriol or sulphuric acid, water must not be used too freely at first, as heat and gas are dangerously produced in the stomach by their meeting (*see acid and alkali*). *Lye, caustic potash, ammonia* and other alkaline poisons are counteracted by vinegar, lemon juice, or acidulated water, to be followed immediately with sweet oil, mucilage and an emetic. *Arsenic, rat poisons, poisonous colorings, paris green, etc.*, give five or six whites of eggs beaten in a cup of water, or flour and water, flaxseed tea or magnesia, and administer an emetic. After the vomiting, give hydrated sesquioxide of

## API

iron in tablespoon doses every fifteen minutes. This is the best known antidote for arsenic. *Corrosive sublimate or bed-bug poison*, treatment the same as for arsenic. *Phosphorus, cochroach paste, matches*, give large quantities of warm water containing calcined magnesia, chalk or whiting. *Verdigris*, give sugar, milk and whites of eggs in large quantities, then strong tea, but no acids of any kind. *Laudanum, opium, morphine*, give an emetic, strong coffee, brandy, whisky, and keep the patient awake by any means. *Poisonous fungi, toadstools, false mushrooms*, give emetics and castor oil or olive oil, then vinegar, lemon juice or cider, and administer ether and antispasmodic remedies. TANNIN is an antidote, and an infusion of gall nuts or oak bark is effective.

ANTISEPTICS—Among substances called antiseptics or disinfectants, are carbolic acid, salicylic acid, boracic acid, chloride of zinc, and iodoform. Chloride of lime, in water used for scrubbing and washing, is the ordinary disinfectant for floors, furniture and linen.

ANTHRACITE—The name of the kind of coal commonly called hard coal. It is nearly pure carbon, makes no flame, but when in combustion at white heat, it will convert a spray of water into flame, and cooking operations are sometimes accelerated by that means.

ANTS—Small red ants overrun the safes and cupboards where eatables are kept; they are particularly troublesome by getting into sugar and syrup; they will attack a sponge cake, go all through and make an ant-hill of it, and will eat bread, but will not touch any cake that has butter in it, nor any kind of pastry made with butter or lard. The small black ants are the most troublesome about cooked meat and in clothing, and from their power to sting. A temporary protection may be had by setting the feet of the safes and cupboards where victuals are kept in bowls of water. When the ants can be traced to their burrows, they may be exterminated most easily by throwing boiling water around frequently. When that is not practicable, it is recommended to take corrosive sublimate—say half a pound—and dissolve it in a quart of alcohol, and apply the mixture to their haunts with a brush. Black ants may be driven away or destroyed by dusting with pepper. Powdered alum or borax sprinkled on the shelves and runways are also recommended.

APICIUS—A Roman spendthrift, gourmand or glutton, whose extravagance made him memorable. There were three of the same name at different periods, distinguished by the same propensities. The second one seems to have spent most of his time sailing about to various ports, trying to find something better to eat, and had a special hankering after large lobsters. The most famous one had a middle name, when he wrote it in full it was Marcus Gabius Apicius. He set up a school of cookery, and spent millions of dollars in pampering his appetite. After

## APP

a while, when he had got so that nothing tasted good to him any more, and he had only half a million dollars left to hire professional cooks with, he committed suicide to save further expenses. **APICIAN FEASTS**—or banquets worthy of Apicius, are expressions sometimes used by reporters.

**APPERT'S PROCESS**—The now common canning process of preserving fruit and vegetables and all sorts of eatables by hermetically sealing and cooking, was formerly called Appert's process of preserving, after M. Appert, a French chemist, who discovered it. It is claimed now that his was but a re-discovery, and that the same method of preserving was known to the inhabitants of Pompeii. It is said that jars of figs, sealed with wax and still in a good state of preservation after the laps of many centuries, were found in the excavations of that buried city.

**APPETIZERS**—*Appetissants*, cold *hors d'œuvres*, kickshaws, side dishes; these are the small things eaten as a preliminary to a good dinner, supposed to create an appetite for something more substantial, though, as one of George Eliot's characters says: "It is poor eating when the flavor o' the meat lies i' the cruet." The favorite in the United States, probably, is raw oysters, four or six on a plate, with half a lemon and crackers. Next to oysters, small clams. Others are as follows: **SARDINES AU PARMESAN**—Strips of toast spread with butter and grated Parmesan cheese and a sardine on top. **ROTIES A LA MINIME**—Split sardines on oblong pieces of fried bread, served with a sauce of oil, vinegar and mustard. **CANAPES A LA PRINCE DE GALLES**—Very small rolls filled with chopped ham, anchovies, gherkins and truffles, the top covered with aspic mayonaise. **TARTINES DE CAVIARE**—Russian caviare spread on small slices of buttered toast. **BISCUITS A LA DIABLE**—Thin beaten biscuits spread with chopped anchovies, hard-boiled egg, capers and parsley. **CROUTES A L'INDIENNE**—Chopped anchovies or sardines, eggs, capers, red pepper and shallots on small buttered toast. **CROUTES AUX ANCHOIS**—Small rounds of fried bread spread with anchovy butter and a filleted anchovy coiled on top. **CROUTES AUX SARDINES**—Same as the preceding. **CANAPES AUX ANCHOIS**—Rounds of fried bread with chopped anchovies and capers and yolk and white of egg arranged in quarters. **SARDINES A LA MARTINACHE**—Sardines dipped in tomato catsup laid upon toast spread with butter and parsley. **OLIVES FARCIES AUX SARDINES**—Stoned olives stuffed with chopped sardine placed on top of small rounds of fried bread spread with mayonaise and decorated with capers. **ARLETS A LA BOLOGNA**—Strips of brown bread and butter sprinkled with finely chopped spring onions, a thin slice of sausage or potted meat and spot of tabasco sauce. **HORS D'ŒUVRES VARIEES**—may be: Farced olives with cucumbers and pulled bread, smoked salmon in thin strips on brown bread and butter, with garden cress cut short

## APP

and sprinkled; caviare with potted tongue and thin biscuit; anchovies or sardines on bread and butter with sliced radishes and leaves of water cress; Roquefort cheese with green butter and radishes on graham crackers; anchovies and potted ham on wafers; sardines scraped, boned, laid in strips crosswise on buttered roll, with capers in the interstices, and a sprinkling of chili vinegar; sardines in halves, minced yolk and white and parsley placed ornamentally on bread and butter, sprinkled with tarragon vinegar; caviare spread on Vienna bread garnished with water cress; shrimps or prawns on rounds of bread buttered, with the smallest lettuce leaves between, sprinkled with tarragon vinegar; grated ham and tongue on rounds of bread buttered, sprinkled with minced spring onions; caviare spread on diamonds of rye or other bread, garnished with lemon and parsley; thin slices of large lemons with sardines or anchovies coiled, bread and butter and parsley. (*For other suggestions see anchovies, sardines, caviare, etc.*) At club dinners and other entertainments many of these relishes are served with the cheese at the close of the meal. A recent innovation is to serve slices of mushmelon or cantelope with salt and pepper, among the *hors d'œuvres*.

**APPLES**—Uses of: **APPLEADE**—A sort of beer made of  $\frac{1}{2}$  bushel apples, baked and mashed, 2 pounds rice boiled soft in 2 gallons water, all put in a tub having a faucet, 7 gallons boiling water and 4 pounds sugar added, and some yeast, when cool. After 24 hours, strain off into a tight keg for use or sale. **BOTTLED APPLEADE**—Same as above except using about an ounce of Irish moss instead of rice, and lemon rind added; bottled, and cork tied down. **APPLE CHAMPAGNE**—Flavor said to be like champagne; made of 2 pounds apples, baked and mashed with 1 gallon boiling water,  $\frac{3}{4}$  pound sugar added and yeast when cool; allow to ferment 24 hours, strained through flannel, bottled and corks tied or wired. **APPLE AND APRICOT COMPOTES OR MERINGUES**—A dish buttered and spread with fine bread crumbs, nearly filled with mixed apple and apricot marmalade, meringue or frosting on top, and baked. **COMPOTE OF APPLES**—Apples in halves dropped into boiling sugar syrup, cooked carefully without breaking until transparent; syrup flavored, perhaps colored, is boiled down thick and poured over them cold. **APPLE BUTTER**—Apples pared and cored, boiled down in an equal measure of sweet cider; is light brown, thick as marmalade; will keep for months, can be bought in various sized packages, is often imitated with stewed dried apples; **APPLE CHARLOTTE**—A pan or mould lined with thin slices of bread dipped in butter, nearly filled with stewed apple or marmalade, top covered with bread, baked brown, glazed with egg and sugar. **CHARLOTTE DE POMMES A LA PARISIENNE**—An apple charlotte in which the slices are cut to form a pattern on the bottom and sides of a thickly buttered mould, the edges being dipped in egg; after baking turned out whole and glazed with egg and sugar, set in the

## APP

oven to crisp, or salamandered. **GERMAN SOUFFLE**—Thick-stewed apple in a dish, thick yolk of egg boiled custard poured upon it, white of egg whipped stiff, sweetened, flavored, piled on top and lightly colored in the oven. **GERMAN APPLE CAKE**—A very thin sheet of light roll dough spread upon a baking pan, cored and quartered apples pressed into the dough raw, sugar sifted over, allowed to rise; then baked until apples are done. **MARYLAND APPLE CAKE**—A shallow mould lined with sweet tart paste, nearly filled with thick-stewed apples or marmalade, well flavored with ground cinnamon, paste on top, dry baked, turned out when cold and sugared over; is also served warm as a sweet entree. **FRIAR'S OMELET**—A pan or mould spread with soft butter and all the fine bread crumbs that will stick, apple marmalade mixed with eggs and nutmeg to nearly fill, covered with bread, baked until set, turned out and sugared over. **ENGLISH APPLE PUDDING**—A deep bowl lined with short paste, filled with sliced apples, covered with paste, tied down in cloth, boiled an hour, served with sauce or sugar and butter. **BOILED APPLE DUMPLINGS**—Short paste made with  $\frac{1}{2}$  pound of shortening to 1 pound flour, rolled thin, cored apple inclosed in it, dropped into boiling water till done. **STEAMED APPLE DUMPLINGS**—Paste with  $\frac{3}{4}$  pound shortening to 1 pound flour, apple core filled with sugar, etc., inclosed and steamed. **BAKED APPLE DUMPLINGS**—Medium puff paste or rich short paste, apple inclosed, leaves of paste or other ornaments on top, washed over with egg and water, and baked. **APPLE DUMPLINGS IN SAUCE**—Made same as steamed, but baked in a pan of sweetened milk and water. **APPLE SHORT-CAKE**—Extra rich, ripe apples chopped raw, spread between short-cakes, (like strawberry short-cake) eaten with sweetened cream. **APPLE COBBLER**—Southern States' name for apple pie baked in an ordinary baking pan and cut out in squares to serve. **BROWN BETTY**—A buttered pudding dish filled with alternate layers of bread crumbs, thinly sliced apples, sugar, little nutmeg, finished with crumbs on top and bits of butter, baked brown; served as pudding. **APPLE OMELET**—Stewed apples beaten smooth, 5 tablespoons of it with 3 of sugar and 1 of flour stirred into 3 well beaten eggs with 1 spoonful of brandy; can be either baked or cooked in frying pans. **FROSTED APPLES**—Apples pared, not cored, stewed in syrup until transparent, without breaking, then drained, dipped in beaten white of egg and in powdered sugar, and dried in the oven with very little heat. **APPLE FRITTERS**—Pared and cored apples cut in rings, dipped in fritter batter, fried in hot fat, served with sweet sauce; also served with roast duck, goose and pork. **APPLE AND CREAM PUDDING**—A mould buttered and lined with rich short paste, quarters of apples built up all over the surface of the paste, the middle filled with pastry cream or frangipane made thick, paste cover, tied in a cloth and boiled an hour or more, turned out and diluted jam poured over.

## APP

**RICE APPLE DUMPLINGS**—Cored and sugared apples inclosed in a covering of boiled rice pounded to a paste, floured outside, tied up separately in cloths and boiled until apples are done; served with sauce. **APPLE AND RICE PUDDING**—Any rice pudding with quartered apples cooked in it. **APPLE TAPIOCA**—A pudding without eggs, milk or butter, made by soaking  $\frac{1}{2}$  pound tapioca for 2 hours in 1 quart of water, stirring in a little sugar, spread in a dish or pan, the top covered with quartered apples, and baked. **APPLE TAPIOCA PUDDING**—The pudding made firm with tapioca and eggs, and sliced apples mixed in, and baked. **APPLE SNOW**—Apples stewed thick and pressed through a colander, beaten up when cold, then mixed with whipped white of egg and powdered sugar; served cold in saucers of cream. **APPLE MARMALADE**—Apples stewed thick and pressed through a colander; sugar, orange peel, lemon peel, cloves or any other suitable flavor added, dried down till thick enough to keep without spoiling. **APPLE SAUCE**—Stewed slices of apples with a little sugar and water. **APPLE PUREE**—Same as apple snow, served in custard cups with whipped cream on top. **APPLE TRIFLE**—Same as apple snow, with thick, cold boiled custard ready; the puree piled in a glass dish and the custard around it. **APPLES AND RICE**—Same as compote of apples, rice cooked with milk and little sugar, smoothed over in the serving dish, and apple on top, custard or colored wine syrup poured over or around it. **APPLE BREAD**—One-third apples, two-thirds flour, apples stewed as dry as can be, mashed through a strainer and used to mix the dough instead of water; yeast, etc., same as usual; baked in loaves. **DRIED APPLE BREAD**—(1) Dried apple boiled until done [but not mashed], drained, stirred up in corn bread, baked in flat cakes. (2) The same stirred up in short-cakes of wheat flour and baked an inch thick in a frying pan over a slow fire. **SNITZ**—Pennsylvania-Dutch name for dried apples. **LODWAERRICK**—Ditto for apple butter. **DRIED APPLES**—Are of two or more kinds, the home-made or sundried generally the cheaper, but by many preferred, and the light-colored, nearly white evaporated, which are in some places treated with sulphur fumes and dried in a current or cold blast of air upon sieves moving upwards in a darkened shaft, whence they emerge almost ready for packing; these apples, with careful cooking, can be restored very nearly to the appearance of the fresh fruit. **APPLE PIE**—(1) A pie plate covered with rich, short paste, heaped full of thin-sliced apples with sugar and nutmeg or cinnamon dusted in, edges wetted, cover of paste put on, washed over with egg and water. (2) A lower crust only, of short paste, stewed apple filling, strips across top. (3) A thin bottom crust with thicker edges of puff short paste, raw apples very thin sliced in, sugar, butter, wine mace added; no top crust; bake slowly. **ENGLISH APPLE PIE**—A deep earthenware dish lined with short paste, filled with sliced apples, sugared and flavored; baked with a crust on top. **FRENCH APPLE**

## APP

PIE OR TOURTE—Small pie plate covered with thin sheet of puff paste with thicker edges, filled with apple marmalade; baked without top crust. APPLE TURNOVERS—Rounds of rich paste cut with scalloped edges or plain; a spoonful of apple marmalade in center, doubled over to half-moon shape, egged over, dipped in granulated sugar and baked till glazed. GATEAUX FOURES DE POMMES A LA PARISIENNE—The French name of apple turnovers. CHARTREUSE DE POMMES—A chartreuse of apples made by parboiling slices of apples, cut in shapes, in strong jelly of different colors, building up the slices on the inner surface of a mould wetted with jelly and set in ice, and filling the center with jelly-stiffened marmalade; to be turned out and served with cream and cake. BAVAROIS AUX POMMES—Whipped cream and apple marmalade mixed with gelatine enough to set the mixture firm enough to turn out of the mould. BEIGNETS DE POMMES A LA D'ORLEANS—Apple fritters with a sweet or wine sauce. BEIGNETS DE POMMES A LA BAVARIE—Apples soaked in brandy, rolled in flour and fried. CRISPED APPLES—American name for the preceding. BUTTERED APPLES—Halved apples baked in a covered pan with butter and sugar, and served on thin rounds of fried bread. POMMES AU RIZ A LA CONDE—Halved apples stewed in syrup, served either upon or around a shape of boiled rice, and diluted apricot jam poured over. BAKED APPLES—The fruit cored, not pared, core holes filled with sugar, butter and little cinnamon; baked with very little water, and basted. PAIN DE POMMES A LA Russe—A border mould of apple jam or marmalade stiffened with gelatine, turned out cold, center filled with whipped cream and melted currant jelly round. APPLES A LA PORTUGAISE—Like the *miro on*; stewed in syrup, not divided, syrup colored red, reduced and poured over; apples, garnished with spots of red jelly. APPLES A LA CHERBOURG—Cut in blocks or shape of bottle corks with tube cutter, compoted in lemon syrup; eaten with cream. APPLES A LA MARIE STUART—Baked apple dumplings in puff paste, the apple core-holes filled with thick cream before baking. APPLE CUSTARD PIES—Several variations are in use; in England they are called puddings; Marlborough pudding is one; apple marmalade is mixed either with eggs and wine, or with eggs, butter, wine and grated lemon rind, or with milk or cream and eggs, etc., and in all those ways, as well as with curd; bread crumbs, currants and eggs, good pies, tarts and cheese cakes are made and still further varied by frosting the top of some and making various sizes and shapes. APPLE FOOL—Old English name for stewed fruit, mixed and eaten with milk, cream or custard. APPLE TARTLETS OR PUFFS—Flat rounds of puff paste, size of biscuits, the middle cut half way through with smaller cutter; baked dry; they rise high; the center is taken out and deep cavity filled with apple marmalade or jelly. APPLE JELLY—The jelly-making quality of apples, varies greatly; crab apples yield the strongest and

## APP

clearest; some seeding varieties, good for nothing else, make the best jelly; 1 pound of sugar to 1 pound of fruit and  $\frac{1}{2}$  pint water, boiled, strained through flannel, tested by cooling, and, if not firm, boiled a longer time. (See *jellies*.) VOL-AU-VENT OF APPLES—Puff paste laid on a pie plate as if for a pie; a mark like a lid cut around near the edge with the point of a knife; when baked and risen the lid lifted off and inside filled with compote apples. GATEAU DE POMMES—A mould of stiffened apple marmalade; served with custard. GATEAU DE POMMES AUX APRICOTS—A mould of gelatine-stiffened apple marmalade covered with apricot marmalade. MIROTON DE POMMES—Cored apples, not divided, carefully cooked in syrup, drained, garnished in a dish with dried or glace fruits; red, currant jelly diluted with wine poured over. CROQUETTES DE POMMES—Apple paste cut in pieces, breaded and fried. APPLE PASTE—Marmalade dried down gradually in a cool oven till it can be spread out in a sheet like a piece of dough, cut in any shape, rolled in powdered sugar; variously colored and flavored, this apple paste is used by bakers to ornament cakes, and is sold as candy in various fancy forms. APPLE SANDWICH—A layer of apple sauce on a slice of bread, covered with a layer of whipped cream. FRIED APPLES—A breakfast dish, also served with all forms of pork; commonly sliced without paring or coring; the peel helping to preserve their shape the slices are simply fried a few at a time in frying (*saute*) pans with a spoonful or two of pork fat or butter, and when brown on one side are turned over one by one; large quantities can be done in the oven if not too many in the pans at once. BROILED APPLES—Same way as broiled potatoes; slices done in the double-wire broiler, buttered while cooking. APPLES WITH SAUSAGES—Fried slices, same as with spareribs and pork tenderloin; this is the German as well as American habit; the Flemings eat baked apples with black puddings. STEAMED OR BOILED APPLE ROLL—A thick layer of chopped apples spread upon a thin sheet of short paste or biscuit dough, rolled up, tied in a cloth at both ends and in the middle, boiled or steamed an hour or longer; served with rich sauce. BAKED APPLE ROLL—The preceding egged over and baked with a greased paper cover over; crust needs to be richer. PAINTED LADIES—Whole (pared) apples cooked in syrup under cover in the oven; when done, each side colored with red jelly, syrup condensed with wine poured over cold. GERMAN APPLE MOULD—One pint Rhine wine, 1 pound sugar, 1 pound apples stewed and mashed through a colander, gelatine to set it, colored pink, moulded; eaten cold. APPLE BATTER PUDDING—Pared and cored apples baked in a pan under paper cover; when done, an egg batter made with little flour poured over the apples, and baking continued. Another way is to bake a thin Yorkshire pudding with sliced apples in it. APPLE CIDER—The expressed juice of apples. APPLE BRANDY—Distilled from either cider or crushed ap-



## APP

ples. **APPLE JACK**—New Jersey name for apple brandy; it is plentiful in most of the eastern states, is generally cheaper than any other spirit and serves a good purpose in cooking, for sauces and for making flavoring extracts. **CIDRE ROYAL OR EAU DE VIE DE CIDRE**—French name for apple jack. "It is the favorite spirit drunk in Normandy; it is also called Calvados, and generally known as such by the Parisians, being chiefly made by the apple-growers in the Calvados department. It is in every way preferable to the so-called cognac, which is made out of anything but wine; sold in France." **WHISKY OR BRANDY APPLES**—Pared and cored apples, to every pound  $\frac{3}{4}$  pound sugar, 1 lemon,  $\frac{1}{2}$  gill whisky or brandy, spices; apples simmered in them without breaking, same as compote apples; placed in jars, syrup boiled down and poured over them; will keep for months. **FROZEN APPLE CREAM**—Marmalade mixed with as much cream, whipped, filled into fancy cases and set in the freezing box to solidify; served as ice cream. **APPLE ICE CREAM**—Apple marmalade and cream or custard mixed and frozen. **APPLE ICE**—Stewed apples flavored with orange and cloves, with twice as much water, well sweetened, frozen and beaten up with whipped white of egg in the freezer to make it creamy. **APPLE AND RICE FROZEN PUDDING**—Custard with boiled rice and thick-stewed apples frozen; also, apple ice and rice custard are frozen separately, but served together. **APPLES**—Stewed with sour kroust and also with cabbage; also boiled whole, with kidneys, are considered an improvement to the respective dishes in certain localities. **APPLE AND WATER CRESS SALAD**—Shredded apples and water cress cut to a corresponding size, tossed up with salt, vinegar, pepper and oil. **APPLES IN MINCEMEAT**—A surplus may be used up in this way, as mincemeat will keep and will sell. **APPLES CANNED**—They are put up in gallon cans for use in regions where there are no fresh apples; are good for nearly all the purposes of the fresh fruit, being generally in unbroken quarters, and being free from waste; are not dear. **APPLES TO KEEP**—A better way than in the cellar is to make a heap of them on the ground in the orchard; if a large quantity, the heap should be a long one, as apples heat if in great bulk; cover with dry straw or hay, then cover with 6 inches of earth; increase the depth of covering before severe frost comes, but the apples are better kept cold than too warm. If a very large lot, have a wooden pipe ventilator inserted. Should apples accidentally freeze in the pit, let them alone and keep air from them, and they will come out afterwards unhurt, but if handled while frozen will be fit for nothing but cider. Car-loads of apples frozen on the railroads during sudden storms are often saved by being at once worked up into cider.

**APRICOTS**—Name is from two words signifying early ripe. It is mentioned by the gardener in Shakespeare's "Winter's Tale," yet only grows in England when protected by a south wall. It reaches the greatest perfection in California, perhaps also

## APP

in Australia, where, a traveler says, some were brought to him three inches in diameter. It is plentiful in France; is a fruit of a delightful flavor and most useful. **RIPE APRICOTS**—Are among the choicest fruits for the table. They are generally wrapped in paper separately and boxed suitably for hotel buyers. **BISQUE OF APRICOTS**—Ice cream with chopped ripe apricots stirred in, the cream or custard previously flavored with the broken kernels and parings simmered in syrup. **APRICOT ICE CREAM**—Canned or stewed apricots mixed with cream or custard and frozen. **APRICOT SHERBET**—Pulp of cooked apricots, about a pint to 2 quarts water and 2 pounds sugar, frozen, and whipped whites of 5 or 6 eggs beaten in. **APRICOTS WITH RICE**—In all the same ways as apples. **APRICOT SHORTCAKE**—With fresh ripe fruit, same as apple, peach and strawberry shortcake. **APRICOT ROLL**—With fresh fruit or with jam, same as steamed or baked apple rolls. **PETITS GATEAUX DE ABRICOT**—Made with apricot marmalade, same as apple turnovers. **APRICOT TART A LA METTERNICH**—An open pie of puff paste, quarters of apricots and pitted cherries laid in and sugared over, baked, and cream-flavored with the kernels poured on top when served. **APRICOT TARTLETS**—Small vol-au-vents of puff paste, as for apple tartlets; the inside lid large enough for half a preserved apricot, the lid not to be replaced, but decoration of red jelly placed around the fruit. **GREEN APRICOT PIE**—The young and unripe fruit is considered to make choice tarts, puddings and pies; it is stewed in syrup until quite tender, then baked in a covered pie, or baked in puff paste without a top crust for a tart. **BAVA-ROIS AUX ABRICOTS**—Apricot marmalade mixed with an equal measure of cream whipped to froth and stiffened with gelatine, nearly an ounce to each quart; set in a mould, turned out, served with marshino cream. **ABRICOT PUREE**—Stewed and strained apricots well sweetened, beaten light, mixed with whipped cream, served cold in custard cups with cake. **GATEAU DE MILLE FEUILLES**—Thousand leaf cake; a pile of thin, round pieces of puff paste, spread with two or three kinds of marmalade and apricot marmalade on top, decorated with candied cherries. **GATEAU GENOISE AUX ABRICOTS**—A pound jelly cake spread and covered with apricot marmalade and served with whipped cream. **TOURTE D'ABRICOTS A L'ALLEMANDE**—An open pie of puff paste, with halves of apricots and marmalade for filing. **APRICOT FLAN**—An open pie like the above, with custard poured on top of the fruit instead of marmalade, and baked in it. **POUDING AUX ABRICOTS**—Like apple cream, pie-stewed apricots mixed with rich custard and bread crumbs, baked in a crust. **APRICOT FRITTERS**—Halves of apricots, either canned or fresh, drained, dipped in fritter batter, fried; served with wine sauce. **BEIGNETS D'ABRICOTS A L'EAU DE VIE**—Rounds of bread dipped in brandy, joined to half an apricot dipped in batter and fried. **APRICOT**

## APP

OMELET—Made same as apple omelet. COMPOTE OF APRICOTS A LA CONDE—Halves of apricots on a bed of cooked rice, the latter sweetened and flavored, red syrup or jelly for a finish. APRICOT WINE—Made by boiling apricots with sugar and water, fermenting same as appleade, but becomes a fine wine if carried through all the processes and kept a year. (*See wines*). CROUTES AUX ABRICOTS—Halves of preserved or compote apricots on fried slices of bread cut in shape; the syrup poured over. PAIN D'ABRICOTS—Marmalade stiffened with gelatine, set in a border mould, turned out and the center filled with whipped cream. DRIED APRICOTS—The best are bleached with sulphur fumes and then dried in the sun.

AQUA PURA—Druggists' latin for plain water.

AQUA VITÆ—Druggists' latin for brandy.

AQUA AMMONIA—Liquid ammonia; used for taking out paint and grease spots.

AQUA FORTIS—Nitric acid; used for testing metal spoons, watches, plate. It eats into the base metals, but does not injure gold or silver.

AQUARIUM—A tank to keep live fish in. In Canton and other Chinese cities, also in Moscow, Vienna and other places, the restaurateurs have these tanks so large and well-stocked as to excite remarks from every traveler. The intention is that the customer shall select his fish, have it caught in a dip net and cooked for him while he waits; much the same as our restaurants keep live quails in a show case.

ARABIAN DISHES—*See Oriental Cookery.*

ARDENNES SALAD—Shredded red cabbage steeped in salt and water, then drained and placed in the bowl, on top endive, sliced boiled potatoes, celery, mustard, vinegar, pepper, and over all is poured the hot fat and gravy from a pan of fried ham.

ARLEQUIN ICES—French spelling of Harlequin; ices of several colors mixed, like a harlequin's dress, such as a brick of ice cream made of 3 or 4 layers.

ARLES SAUSAGES—A kind formerly in fashionable repute; not very different from the now well-known Frankfurt; named for the town where made.

ARMENIAN CABBAGE A LA MODE—A cabbage boiled about half done, taken up and minced meat of any kind, well seasoned with pepper and onions, introduced between the leaves, which are then tied around with twine; the stuffed cabbage is then fried in butter, gravy made in the pan and cabbage allowed to stew in it.

AROMATS, AROMATICS—Words often used in cookery recipes to avoid repeated enumeration. They signify the roots, herbs and spices commonly used for seasoning or flavoring savory dishes, such

## ART

as shallots or onions, garlic, sage, bay leaves, thyme, celery, mace, cloves, etc.

AROMATIC SALT—Also called *spiced salt*. It is fine salt having the powdered herbs and spices mixed with it, which are used by cooks, and saves the trouble of getting each one of the ingredients together as often as they are needed. Spiced salt contains pepper, mace, bay leaf, rosemary, sage, thyme, celery seed, and perhaps other ingredients, for cooks of different nationalities have various preferences in that respect.

ARROWROOT—A pudding material like corn starch, but has a more delicate flavor of its own. Being a product of the West India islands, the powers owning them have done much to stimulate the trade in arrowroot from commercial motives, and numerous recipes may be found in which arrowroot is an ingredient, but corn starch takes its place most completely, whether for puddings, custards, blanc mange, cakes, crackers, etc., and being cheaper crowds it out of the market. In making puddings, about one-third more of arrowroot is required to a certain measure of liquid than of starch, and the price of arrowroot is much higher. It remains the best material, however, for thickening milk for ice cream, and is much used as a diet for invalids. The name is in reference to arrowroot being obtained from the root of the manioc, which yields at the same time a poisonous sap into which the native Indians dipped the points of their arrows. This all washes out in water, while the pure arrowroot sinks as sediment and is afterwards dried and powdered.

ARTESIAN WELLS—Holes are bored or drilled to any depth by either of two methods: A drill with a wedge-shaped steel point is raised and let fall by steam power, its own weight driving it down while it is turned part way round at each drop to make the bore round. At intervals of a few hours an iron tube is let down to draw up the mud and water. By the other method the drill is a short tube with rough diamonds set in the lower edge, which cut down into the rock while the drill is revolved by the machinery. This drill brings up a core from the strata penetrated, and is most used for prospecting. The largest bore so far has been 12 inches in diameter and deepest about 3,000 feet. In low lands water is often obtained that gushes up with great force several feet above the surface; these are called flowing wells. In most large or medium-sized cities parties can be found who take contracts for sinking wells where wanted. Artesian wells get their name from Artesium, the ancient name of Artois in France, where these methods began to be used about 150 years ago.

ARTICHOKE—There are two different vegetables called artichokes, and neither of them being in general use with us there is a good deal of mystification about the directions given for using them. One, the artichoke straight, is a sort of thistle, the

## ART

green immature flower, with a little eatable material about the base; the other, the Jerusalem artichoke, is the root of a small sort of sunflower; it is like a misshapen potato. The directions given for cooking one look foolish when applied to the other. There are so many better vegetables that neither kind of artichoke is much thought of; the Jerusalem artichoke had its day before the potato came into general use. It is claimed now that it contains more nutriment than the potato, will grow anywhere and can remain in the ground all winter without injury. This root artichoke grows wild in the western prairie states. How the two dissimilar vegetables came to be called by the same name nobody now knows, but the term Jerusalem does not mean what it purports to; it is a corruption of *girasola*—an Italian word meaning sunflower. Still this mistaken name has led to a soup made of a puree of Jerusalem artichokes—like potato soup—being known everywhere as Palestine soup, in reference to Jerusalem city being in Palestine.



This, the thistle or globe-artichoke, is cultivated extensively for market over the water and to a small extent in the United States. It is also dried and exported. When to be cooked, the dried artichoke is steeped in water. It is the white part that is eatable; the center, called the choke, is cut out when the vegetable is half cooked, when it can be removed easily. **STUFFED ARTICHOKE**—The leaves and bottoms pared off, choke removed, cavity filled with stuffing, baked, served with a sauce or as a garnish to a dish of meat. **ARTICHOKE A LA BARIGOLE**—The cavity filled with a fine herbs mince of mushrooms, parsley, shallots and minced pork in espagnole thickened, baked with a slice of pork over each stuffed artichoke, served without the pork, sauce

## ASP

over. **ARTICHOKE A LA LYONNAISE**—Trimmed and pared down to the fleshy part, cut in quarters, cored, parboiled, simmered tender in seasoned broth; served with onion sauce, brown. **ARTICHOKE AU NATUREL**—A Parisian authority contends that the only way to serve artichokes well is to steep them in cold water 2 hours, boil 1 hour, eat by pulling off each leaf with the fingers and dipping the eatable base in melted butter. **ARTICHAUTS A LA GOUFFE**—Fried in batter, same as egg plant. **ARTICHAUTS FARCIÉS A L'ITALIENNE**—Parboiled, insides removed, stuffed with bread, onion and grated cheese, cooked in little stock in a covered pan, served with brown Italian sauce. **ARTICHAUTS A L'ITALIENNE**—Quartered, cooked in wine and stock, served with white Italian sauce. **ARTICHOKE SALAD**—(1)—The bottoms chopped small, mixed with heart lettuce also chopped; seasoned with oil vinegar, pepper and salt. (2)—Artichokes previously pared and quartered and steeped in water, containing lemon juice, are eaten as salad alone, with the usual seasonings. **ARTICHAUTS A LA HOLLANDAISE**—Plain boiled and served with Hollandaise sauce to dip in. **ARTICHAUTS A LA BONNE FEMME**—The same served with white sauce. **ARTICHAUTS A L'ESSENCE DE JAMBON**—Stuffed, braised and served, covered with a puree of ham. **ITALIAN GOBBO**—The growing leaves of the globe artichoke are doubled back, tied and covered with earth and white lumps form on the stalks, which are called *gobbo*; this species of salad is eaten raw with salt. **ARTICHOKE, JERUSALEM**—The French name for it is *Topinambour*, the old name of potatoes. This tuber is apt to turn dark in cooking as salsify does. To prevent that it is thrown into water containing vinegar as soon as pared, and not allowed to remain on the fire after it is done. A very general use of it in the southern states where the plant may be found growing in garden corners without attention is as a pickle; it is put up the same way as cucumbers, only scalded, not cooked soft. **TOPINAMBOURS A L'ITALIENNE**—Cut in shapes, stewed in stock, served with sauce. **TOPINAMBOURS AU GRATIN**—Jerusalem artichokes boiled, mashed and baked with grated cheese on top. **TOPINAMBOURS A LA SOYER**—Shaped like pears, boiled in water with onions, butter and salt; served with butter sauce poured over. **ARTICHOKE FRITTERS**—Same way as parsnip or salsify fritters, by mashing, mixing with egg and dropping spoonfuls in hot lard. **FRIED ARTICHOKE**—Done same way as fried egg plant. **ARTICHOKE SOUP** ("Palestine Soup")—Made with 12 ounces Jerusalem artichokes to each quart of chicken stock; turnips, celery and leeks added; all vegetables passed through a seive, and cream and yolk of eggs added—it is a cream puree of artichokes.

**ASPARAGUS**—Is eaten with the fingers when cooked, whether hot or cold; for this reason asparagus on toast is dished with the heads only in the butter or sauce, the toast holding up the white ends

## ASP

dry. The largest on record were a hundred heads grown at Mortlake-on-the-Thames which weighed 42 pounds, the bunch. Another hundred presented to George II in 1737 weighed 28 pounds. A tall story has recently been in print of a traveler having discovered a giant species of asparagus 12 inches thick, growing wild in Russian Asia, of which one head was enough for a party of six. The larger the head the poorer the flavor, however, and the medium-sized green tinted is the best eating. It might be grown in the garden of almost every hotel, as it only needs planting once to come up in the same spot for years. The shoots which escape cutting grow to a beautiful plant with feathery foliage and bright red berries, making a fine decorative plant for ball rooms, banquet rooms, etc. Asparagus possesses medicinal qualities similar to the water of sulphur springs, which causes it to be adopted as a diet in the canned state when it cannot be obtained green. ASPARAGUS EN BRANCHE—Is plain boiled and served in bunches, full length. ASPARAGUS PEAS—Are the *pointes d'asperges*, the green heads cut small and served in soups and sauces. CONSOMME AUX POINTES D'ASPERGES ET ŒUFS POCHES—Is clear soup with asparagus heads and poached eggs, same as a *l'Imperatrice*. *Consomme Printanere* always has asparagus heads. ASPARAGUS SOUP, PUREE OF ASPARAGUS, CREAM OF ASPARAGUS are three kinds in which this vegetable is the principal ingredient. ASPARAGUS A LA CREME—The green heads, boiled, in Bechamel sauce. ASPARAGUS EN HOLLANDAISE—Served on toast with that sauce poured over the heads, instead of *au beurre*, with butter, or *au jus*, with gravy. ASPARAGUS EN MAYONAISE—The heads cooked, cut small, seasoned, and served cold as a salad with dressing. ICED ASPARAGUS—The heads dressed in oil and vinegar, and frozen. ASPARAGUS OMELET—The green heads cooked and drained, mixed in an omelet. STEWED ASPARAGUS HEADS—The heads partly fried (*saute*) in bacon fat, with chopped parsley, chervil salt, pepper, and slight grating of nutmeg, stock and gravy added, simmered, skimmed, served on toast. CHOPPED ASPARAGUS A LA POMPADOUR—Boiled green in salted water, the heads cut off, of good length, placed on hot cloth near the fire. Some hollandaise of butter yolks, salt, pepper, little vinegar, cooked in a pan in boiling water till just thickened, and poured over asparagus. ASPARAGUS WITH CREAM—The heads cut small, blanched in boiling water for 3 minutes, simmered in a saucepan with butter, lump of sugar, an onion, very little water; onion removed, cream added and thickened slightly; served on toast. ASPARAGUS WITH EGGS—Cold, served *en branche* or full length, with olive oil and quarters of hard-boiled eggs. ASPARAGUS STUFFING—Chickens and pigeons are filled with asparagus heads, seasoned, sewed up and roasted over toasted bread. ASPARAGUS TO BOIL—The stalks, after being scraped and washed, are tied in bunches and the butt ends cut off even,

## ASP

to make them of one length. The water has salt in it and a pinch of soda, and should be boiling when the bunches are dropped in. The soda preserves the green color if the lid is kept off the saucepan. Takes about 20 minutes to cook. The very slender and green stalks of asparagus are called sprue and cooked like greens. DRIED ASPARAGUS—Soyer tells us that the Romans dried asparagus for use in winter and restored it by soaking in water. CANNED ASPARAGUS—Is good except in the one respect of the heads being generally broken. It should not be taken out of the cans to cook, but the cans opened at the butt, as shown by the label, set on the range and the stalks served from the can. ASPARAGUS CREAM A LA NOEL—A French restaurant specialty; an entree formed in a mould and turned out; made of asparagus and breast of chicken in equal parts, chicken pounded and forced through a seive and mixed with little veloute, asparagus divided into green puree and white puree. Half the chicken paste mixed with the green, other with the white; green in buttered mould first, white to fill. Steamed an hour without letting it reach boiling heat; turned out and bordered with green asparagus prepared separately. The special mould is in shape of a fine bunch of asparagns.

ASPIC JELLY—Is meat jelly, such as is obtained by boiling calves' feet or shanks or chickens down to jelly, but to make it handsome, for ornamental purposes, it is clarified with white of eggs and strained through flannel, and, to save labor, it is oftenest made of gelatine added to clear soup. If the soup is already rich and strong, 1½ ounces gelatine to each quart makes a jelly firm enough to be handled and stamped into ornamental shapes. It is necessary for the aspic jelly to contain white wine and lemon juice as two of the ingredients, but the remaining flavorings may be according to the cook's taste and judgment, the intention being to provide a jelly of a spicy taste—tasting like a savory game pie or any meat pie, or like head cheese, but clear as glass and finely colored with burnt sugar or with saffron or cochineal. When made it is kept in a jar on ice till wanted, or in thin sheets or dishes to be cut in fancy shapes.

ASPIC MAYONNAISE—Is aspic jelly and mayonnaise mixed together, forming a shining yellow jelly, not transparent. Is also made by stirring mustard, etc., into aspic.

ASPICS—Dishes of all savory sorts that are put together with aspic jelly or aspic mayonnaise, such as pieces of fish placed in order in a mould and fastened there with aspic jelly, the mould being set on ice and the interior filled with something solidified by having melted jelly mixed in, or chicken, shrimps or lobster on a flat dish with aspic cooled upon or around them. ASPIC OF SOLES OR OTHER FISH—Fillets of soles rolled up cone-shape are steamed, half of them placed point downwards in a mould, melted pale aspic jelly poured in to just cover; set in

## ASS

ice to become firm. Some jelly colored green poured into the next tier of fillets point upwards on top of the former when set solid. Yolks of hard-boiled eggs rubbed through a sieve, mixed in more jelly to fill up mould when again set. Turned out on a lace paper covered dish; highly ornamented. **ASPIC OF FILLETS OF TROUT**—A dozen fillets of fish with butter and seasonings lightly baked in a covered pan and then cooled with a light weight upon them to flatten. When cold, cut out rounds about size of silver dollar are placed in order in a mould lined with a coating of aspic by turning it about on ice and parsley, eggs, anchovies in strips, and capers added in ornamental patterns, the inside filled with more fillets mixed with mayonnaise jelly. Aspics of poultry livers, ox-palates, quenelles, fillets of game, chicken, turtle fins, plovers' eggs and almost anything can be made either in moulds or in flat dishes surrounded with a green salad, or in a border mould, the center to be filled with a salad after it is turned out. **ASPIC A LA CZARINA** (Club specialty)—The meat of 3 grouse pounded in a mortar, seasoned, passed through sieve, mixed with a pint of whipped cream, little aspic and chateaufroid sauce. Set in a square shallow mould on ice. Turned out, dressed with brown chateaufroid sauce, decorated with truffles and aspic on a stand of rice, and surrounded with green salad.

**ASSAFŒTIDA**—A mal-odorous gum which has the taste and smell of garlic intensified. It is obtained from a shrub. Is used in small quantities to impart the garlic flavor to some bottled table sauces. Among the accounts of ancient banquets we find mention of kid dressed with assafœtida, and it has been used as a seasoning in later times. One present use of it is to carry about the person as a protection against contagious diseases, such as yellow fever. It is reputed to have virtues in that respect similar to camphor.

**ASSES' FLESH**—The market statistics show that 500 asses and mules were slaughtered and sold in Paris last year, as well as 1,800 horses, for meat. The asses' flesh sold at 2 cents a pound higher than horse-flesh.

**ASSES' MILK**—Has had a run at various times as a health food for children and consumptives. There used to be milk-stands in the London parks where the donkeys, sleek, curried and beautifully kept, were milked to order for children and other customers as they came.

**ASSIETTE** (Fr.)—Dinner-plate.

**ATELETS OR HATELETS**—Skewers, some of silver with ornamental heads are for decorating cold dishes, others for cooking "kebobs" on or any meats *a la brochette*.

**ATTELET** (Fr.)—Bleak, a small fish.

**ATTEREAU DE ROGNONS**—Brochette or skewer of chicken kidneys, a French restaurant specialty. Cook some "rognons de coq" in white

## BAC

stock, allow them to cool in their liquor; drain; run on silver skewers with cockscombs between. Cover with chateaufroid sauce, then with beaten egg, bread crumb them and fry. Served on the skewers, garnished.

**ATTEREAUX** (Fr.)—The ornaments cut out of firm aspic jelly for bordering dishes.

**AU, AUX**—To or with; as beef *au celeri* or *aux oignons* (onions); *au* is used when the accompanying article is but one thing, and *aux* when it is many.

**AU GRATIN**—With a brown or toasted surface. **AU JUS**—With gravy. **AU JAMBON**—With ham. **AUX CHAMPIGNONS**—With button mushrooms.

**AUBERGE** (Fr.)—An inn.

**AUBERGINE**—The egg plant.

**AURELIAN CAKE**—A rice sponge cake, of  $\frac{1}{2}$  pound ground rice,  $\frac{1}{2}$  pound sugar, 12 eggs with 3 of the whites left out, brandy and flavoring. Made like sponge cake.

**AURORA SOUP**—*Potage a l'Aurore*, or soup blushing like the morning; the fanciful name given by a cook to a soup made orange-colored, with a puree of carrots and further thickened with yolks of eggs.

**AURORA SAUCE**—Lobster butter made by pounding lobster coral (the egg) and butter together, mixed in white sauce. It is pink, and when lobster coral cannot be obtained is colored to imitate it. Lemon juice, salt and cayenne required in the sauce. Served with fish.

**AVENA**—Latin name of oats. **ROLLED AVENA**—Crushed oats or oatmeal.

**B.**

**BABA**—Polish cake in common use; a yeast-raised, white sort of fruit cake, made of sugar, butter and eggs, few raisins and almonds mixed with a piece of light dough about equal in weight to all of them, thoroughly beaten; let rise in moulds, and baked. **BABA AU RHUM**—The baba cake served as pudding with hot syrup, containing rum, poured over it.

**BACON**—Needs to be timed in boiling to  $\frac{1}{2}$  hour for each pound. **BACON, BROILED**—Thin slices broiled to a crisp over a charcoal fire. **BACON WITH EGGS**—The bacon on the dish first, and fried eggs on top. **BACON OMELET**—Lean bacon minced very fine and lightly fried, the fat poured into another pan, and omelet poured into that, cooked bacon strewn all over the surface; when soft cooked, rolled up, garnished with parsley in the dish. **STUFFED BACON**—Cut thin, but slices left in pairs, not quite separated; stuffed with mashed potatoes and rolled in cracker dust or crumbs; fried. **BACON AND SPINACH**—Slices of boiled bacon laid upon a bed of seasoned spinach. **BACON AND FISH**—Broiled or fried bacon is the best accompaniment to fried or broiled trout, bass or other fresh-water fish. **BACON**

## BAC

AND BEEFSTEAK—Broiled steak, with a slice or two of broiled bacon on top, is esteemed a luxury. BACON AND CABBAGE—Boiled together and slices of bacon served with cabbage. BACON AND GREEN BEANS—In some parts of the states string or snap beans will hardly be eaten without bacon; it is boiled along with them, and small pieces cut and served in each dish sent in. BACON AND WHITE BEANS—The French cooks think it all right to boil navy beans plain and serve them with a slice of bacon on each order—it is their substitute for baked pork and beans, which they seldom cook. BACON WITH CHICKEN—Boiled chicken and turkey go well with boiled bacon, but the unsmoked or very light smoked is required—the “bulk meat” or salt pork. BACON IN CANVAS—Is too dear for constant use, the weight of the wrappings having to be paid for, and the quality of bacon is hidden; thin and unserviceable pieces that trim half away are covered up in canvas, of which the only use is to keep insects out of the meat for those who keep it in stock. The most profitable to buy is bacon by the box of 50 to 100 pounds, well smoked, free from bone and not canvassed. The removal of the bones from the rib sides will be found to cause much waste of the meat at the same cutting unless use can be found for such outside cuts. BACON AND SAUERKRAUT—Should go together.

BACKBONE—Chine of pork; the American bacon maker's cut, being the entire backbone of the hog from the ears to the tail, the latter included. BACKBONE STEW—Country luxury; the backbone chopped in convenient pieces, stewed with an onion, potatoes, pinch of sage, salt, pepper, and flour to thicken. BACKBONE POT PIE—The stew in a wide pan, spoonfuls of biscuit dough dropped in. BACKBONE PIE—The stew in a baking pan, covered with sheet of paste, and baked. BAKED BACKBONE—Chopped in convenient pieces, salt, pepper and sprinkling of sage; baked brown. The bones being exceedingly abundant in packing house localities make a glut of pork food at certain seasons like the gluts of fish in other places. Stuffed chine, broiled bones with fried apples and apple sauce, bones with Robert sauce, bones with onions, and in many of the ways of regular pork cooking are then equally in vogue.

BADGER—Like a small bear; eaten by hunters and trappers; tastes like wild boar.

BAG PUDDINGS—The kind of puddings named in the poem: “A bag pudding this king did make, And stuffed it well with plums, And in he put great lumps of fat As big as my two thumbs.” Christmas plum or egg batter or other kinds tied up in a bag and boiled.

BAGRATION (*a la*)—A few preparations bearing this designation, perhaps half a dozen, one-half of them being soups, were so named by Carême in compliment to a countess of Bagration of his time. They are all combinations of fish and vegetables.

BAHAMA SAUCE—A fish sauce composed of

## BAK

the liquor in which a fish is simmered with Bermuda onion, Bahama chillies, wine, broth, parsley, etc.

BAIN-MARIE—A double kettle of any kind, the inner vessel surrounded by water, like a farina-kettle or glue-pot.

BAKING POWDER—Cream of tartar, 30 oz.; bicarbonate of soda, 15 oz.; flour, 5 oz.; mixed. “I chanced to pick up as my dinner companion one of the officers of a leading baking-powder company. Probably others will be surprised as was the loungee to learn that their sales of the single article of baking powder reach \$3,500,000 or more. At 35 cents per pound this represents the distribution of 10,000,000 pounds of powder. I managed to worm out of my friend that the company has a capital of \$160,000. Then I commenced to do a little figuring on my own account. I happened to have in my note-book the formula for a baking powder, viz.: 100 lbs. cream tartar, 38 lbs. bicarbonate of soda, 7 lbs. tartaric acid, and 20 lbs. rice flour. Taking the latest current quotations of these articles I figured out the cost of a batch of baking powder, and, with that as a basis, we came to the conclusion that the company must divide up somewhere from \$600,000 to \$800,000 a year. We no longer wonder why the stockholders build rows of brown-stone fronts in Brooklyn. I then wheeled around and asked my companion the secret of the success of his company against many rivals, when he replied: ‘There are just two things about it. First, we resolved to make the best baking powder that could be made, and, second, to let the people know it.’ We imagine that is the reason why they advertise in over 5,000 different newspapers and compel the grocers to keep their baking powder in stock, whether they want to or not.”

BAKING POWDER BRIOCHES—Sweet buns raised with powder instead of the customary yeast; the bun is dipped in a wine-flavored syrup after baking.

BAKED BEANS—White haricot or navy beans, steeped in water for several hours, are then baked in a stone jar with salt, piece of salt pork and small quantity of molasses; allowed to remain in the oven 8 or 10 hours. Cooked in that way the dish is called Boston baked beans to distinguish from another way of cooking rapidly by boiling with soda in the water, then seasoning and baking in a pan.

BAKEWELL PUDDING—The Derbyshire (Eng.) specialty, from the ducal residence of Chatsworth, famed for having the highest fountain jet in the world. The pudding is an open deep pie, made by spreading a layer of preserves on the bottom crust of puff paste; apricot, peach or cherry preserves are suitable; adding thin strips of candied orange peel or citron, then making a rich “transparent pie” mixture of butter, sugar, 6 oz. of each, 4 eggs, lemon-flavored brandy, and 2 oz. flour, spreading on top of the preserves and baking very carefully, for it is easy to burn on top.

## BAL

**BALL SUPPERS**—Ball suppers were most unsatisfactory affairs until Ude, the French *chef*, hit upon a plan of serving a supper which should at once satisfy the guest by the excellence of the repast and the novelty of the arrangement, and the host by the smallness of the expense. This plan is to ornament the sideboard with a basket of fruit, instead of insignificant pieces of pastry. Place in their stead things that can be eaten—such as jelly, plates of mixed pastry, and sandwiches of a superior kind, but not in too great profusion. Affix a label to each plate, indicating its contents, and you will find this arrangement will give the guests an opportunity of taking refreshments without being obliged to seat themselves at a table from which the ladies cannot rise without disordering their dresses, which to them is a matter of far greater moment than the best ball supper in the world.

**BALL STAND-UP SUPPER**—Humorously described by Theodore Hook as “tables against the wall, covered with cold negus and warm ice; where men, women and children take perpendicular refreshments, like so many horses with their noses in the manger.”

**BALL SUPPER WASTE**—The waste of ball suppers of old was almost incredible. Ude states that he has known balls where the next day, in spite of the pillage of a pack of footmen, he has seen 20 or 30 hams, 150 or 200 carved fowls, and 40 or 50 tongues given away; jellies melted on the tables; pastry, pâtés, pies and lobster salads, all heaped up in the kitchen and strewn about the passages, completely disfigured by the manner in which it was necessary to take them from the dishes in which they had been served.

**BALLOTINES**—Ballotines are small galantines made by treating small birds as directed, only that the force-meat should have a larger proportion of truffles, and be made of the same kind of bird; for instance, grouse would have a rich force-meat of grouse. One grouse, however, would make two or four ballotines; quails make two, to be served as individuals. (*See galantines.*)

**BANANA**—Fruit of tropical and semi-tropical countries and is the principal food of natives of some West India islands. Exaggerated statements of the amount of nutriment contained in bananas have been circulated, shown to be fallacious by drying the fruit, which parts with  $\frac{3}{4}$  of its weight as water. Remainder is like sweet dried pumpkin. **CANDIED BANANAS**—Dried bananas crystallized in sugar before quite dried out. **BAKED BANANAS**—Breakfast dish; split, laid in pan with butter and sugar over, baked to a state like candy. **FRIED BANANAS**—Either whole or cut across, dipped in syrup, then rolled in flour and dropped into hot oil or lard till crisp outside. **BANANA FRITTERS**—Cut in two across, steeped in rum or any liquor or wine and sugar; drained, dipped in fritter batter and fried; rolled in powdered sugar or served with a

## BAR

sauce. **BANANA PIE OR PUDDING**—Mashed, mixed with sugar, lemon juice, butter and eggs, and baked in a dish with bottom crust of paste. **BANANA COVERED PIE**—Sliced, sprinkled with lemon juice, sugar, bits of butter, moistened with wine or brandy, baked with bottom and top crust. **BANANA ICE CREAM**—Two bananas, pulped, to each quart of cream. **BANANA CANDIES**—Flavored with extract; also, in imitation of peeled bananas. **BANANA CAKE**—Two sheets of cake, sliced bananas dipped in sweet wine laid between; banana-flavored yellow icing on top. **BANANAS FOR THE TABLE**—Among the very best of fruit. They have the ends cut off, are wiped with a cloth and placed on stands in their skins. **BANANA AMBROSIA**—Cut up with oranges, cocoanut, wine and sugar. **BANANA FRITTERS (2)**—Mashed bananas  $1\frac{1}{2}$  lbs., flour  $\frac{1}{4}$  lb., sugar 2 oz., lard 2 oz., and 1 or 2 eggs. Dropped by spoonfuls in hot lard. Bananas baked are served up with baked monkey in Brazil, like our opossum with sweet potatoes.

**BANBURY CAKES**—A popular kind of turnover or puff, having a mince mixture inside of a fold of puff short-paste. The mince is variously compounded, either with crumbled slices of cake, chopped apples jam, candied peel, and spice, or with butter and sugar stirred together, and raisins, currants and peel added. Paste rolled thin, is cut out with an oval cutter having scalloped edges, mince placed in the middle, edges wetted; another paste on top, egged, top dipped in sugar and baked.

**BANNOCKS**—Scottish; Cakes made of barley or oatmeal, baked on an iron plate or girdle or griddle.

**BARM**—Scotch bakers' name for liquid yeast as made by them. The ordinary “ferment.”

**BARATARIA SHRIMPS**—The name now so widely diffused as a brand of canned shrimps, has reference to Baratavia Bay in southern Louisiana, once the rendezvous of the pirate Lafitte; locally famous also for its large oysters.

**BARMECIDE FEAST**—A great array of dishes, but little or nothing on them. There is a story in the Arabian Nights of a prince of the Barmecides family who invited a number of people, his dependents, to dinner. The table was set, each dish having a cover over it, according to the old fashion. When the signal was given the covers were raised and showed the dishes absolutely empty. Nevertheless, the host went through the motions of helping himself out of the various dishes and pretending to eat and get filled up, and the guests, being his dependents and afraid of him, had to do the same and pretended to have had a good dinner, though they had not had a mouthful. The Barmecide prince had some motive in this which the story tells, and from this story comes the allusions to Barmecides and their banquets.

**BARBUE (Fr.)**—Brill, a fish.

**BARTAVELLE**—Barnade bird; Scotch goose.

## BAS

**BARLEY**—For cooking purposes is of two kinds or more: Scotch and pearl barley; the latter is larger grain and whiter; either kind answers for cooking; both are cheap, costing less than rice and swelling to a great bulk in boiling water. **BARLEY BROTH**—Mutton, barley, turnips, onions, or leeks, and water; not thickened otherwise than with the barley. **BARLEY SOUP**—Meat stock and various vegetables cut small, some barley well boiled separately and added along with flour thickening. **CREAM OF BARLEY**—A rich white soup of chicken or veal, or other white stock, with celery and mixed vegetables; barley rubbed through a strainer, cream or milk and little butter and parsley. **BARLEY WATER**—Gruel for the sick, made by boiling barley in two waters and straining off. **BARLEY PUDDINGS**—(1)—Boiled barley with butter and a custard mixture of eggs and milk; baked. (2)—Boiled barley stirred up with molasses and suet; baked. **BARLEY BREAD**—Made of a mixture of barley meal with flour. Scarcely known in this country, but used in lands where there is no cornmeal. **BARLEY BANNOCKS**—Flat cakes of barley meal baked on a griddle; very thin.

**BARLEY SUGAR**—Old-fashioned sort of clear stick candy. No particular reason for the name, but taste resembling barley malt.

**BARNACLES**—A shell fish; like a mussel, but only about an inch in length; said to be eaten by the Chinese, Japanese, and others. Barnacles attach themselves to floating logs and wooden piles, and to the bottom of vessels.

**BARSZEZ**—Polish beet soup. On the occasion of a banquet given by Prince Czartoryski in Paris, this soup figured on the menu, the recipe having been sent from Cracow for the purpose. It was made by filling a good sized jar with slices of raw beets cut small, covering with water and placing a slice of bread on top. Covered and let ferment, which takes from 3 to 5 days. Skimmed and the juice passed through a sieve, then boiled with an equal proportion of strong beef stock, to which was added small pieces of ham. The soup went to table looking clear and red.

**BARBECUE**—See description at page 164.

**BARBEL**—A fish of "the other side;" not very highly valued. It is generally broiled.

**BARBEAU** or **BARBILLON** (Fr.)—Barbel.

**BARBE DE CAPUCIN** (Fr.)—Monk's beard; name of a salad herb; chicory.

**BARDS** (Fr.)—Slices of pork or bacon, which are laid upon the breasts of grouse, etc., and wrapped around small birds before cooking.

**BARDES** (Fr.)—Barded or covered with slices of fat bacon.

**BASIL**—One of the standard "pot herbs;" it is thought to be specially suitable for turtle soup; can be grown in any kitchen garden like thyme, marjoram, etc., and can be bought, dried and powdered, in cans.

## BAS

**BAR** (Fr.)—Bass. **BASSE** also.

**BASSE RAYEE** (Fr.)—Striped bass.

**BASS**—There are half a dozen or more kinds: Black bass, northern; black bass, southern; striped bass, rock bass, channel bass, sea bass or red fish; all regarded first-class for the table and for sport. The southern black bass is a coarser looking fish than that of the North; its scales are larger and it is not so finely marked as its northern brother, neither is its flesh so firm and hard; but the meat is very sweet and it does not have the strong grassy taste that some of those found in western waters have. It is the best fresh-water fish found in the South, notwithstanding it seems to be one-third head—it is the large-mouthed variety. Northern bass have the quality of keeping fresh longer than other fish, and are safe kinds to buy and satisfactory to serve, especially in restaurants where one or two pound sizes are in demand. **BROILED BASS WITH BACON**—A favorite way of calling for bass. The fish scored deeply on each side and broiled whole; crisp-broiled bacon served on top of the fish and cut lemons the only sauce. **BROILED BASS**—Split, dipped in flour, broiled, basted with butter brush, served with maitre d'hotel butter. **BASS A LA MAITRE D'HOTEL**—Broiled whole, butter worked up with parsley and lemon juice spread over the fish. **BASS STEWED**—In shallow saucepan whole, with onions, can tomatoes, little wine, espagnole sauce, salt, pepper, parsley, stewed 40 minutes. Sauce reduced and strained over. **BASS A L'ETUVEE**—Stewed bass. Cut up, white butter sauce mixed with onions made and fish stewed in it; claret, nutmeg, parsley, sauce and croutons. **BASS IN MATELOTE**—Matelote is a fish stew. This has cut-up fish cooked in red wine stock, dipped out, sauce strained and thickened, glazed small onions and mushrooms added. **STUFFED BLACK BASS, CRAYFISH SAUCE**—Fish opened, stuffed, tied together, simmered in wine stock in covered boiler. Gravy thickened with flour and egg yolks and made pink with lobster or crayfish butter; crayfish tails garnish. **STRIPED BASS A LA CONTE**—Whole, baked in oven with oiled paper over and wine and broth in the pan, oil, salt, pepper, shallots, parsley, sauce thickened, espagnole added, strained over. **FILLETS OF STRIPED BASS A LA BORDELAISE**—Each fillet cut in two, being 4 from each fish, steeped in oil and lemon juice, drained and dusted with flour; dipped in egg yolk mixed with warm butter and in bread crumbs, and broiled. Sauce made of heads or bones boiled down and tomato sauce added. **FILLETS OF BASS A LA MANHATTAN**—The flesh of the fish chopped fine, made into flat croquettes and fried. Dished in circle, tomato sauce in center. **FILLETS OF BASS EN PAPILOTTE**—Small pieces well shaped partly fried in butter; taken out, and thick pasty sauce made in same butter of onions, mushrooms, wine, thick veloute, parsley, yolks, poured over the fillets and cooled. Each fillet on a sheet buttered note paper with the sauce covering, paper doubled over and



## BEA

edges pinched, baked brown; fine herb sauce. **BAR A L'EAU DE SEL**—Plain boiled in salt water. **BAR SAUCE AU BEURRE**—Broiled and served with butter sauce.

**BAT**—There is a kind called the edible bat; body about 10 inches long, flesh white, tender, delicate; eaten in the East Indies.

**BATRACIAN**—Scientific name of the frog, and used frequently as a synonym.

**BATTER**—Thin mixture of flour with some liquid; generally, to "make a batter" means flour and water mixed smooth, then eggs, melted butter, salt, sugar, etc., added. **FRITTER BATTER**—Is thick enough to coat over whatever is dipped in it. **PAN-CAKE BATTER**—Is about as thin as cream.

**BATTER PUDDINGS**—About 5 oz. flour to each quart of milk, 2 eggs, spoonful melted lard or butter and same of sugar makes a batter like thin cream which sets solid when baked. **BATTER PUD-DING WITH APPLES**—Baked apples in quarters in a pan, batter poured over and baked again. **BATTER PUDDING WITH RAISINS**—Same way without previous cooking of fruit. All batter puddings have to be shallow in the pan.

**BAVARIAN CREAM**—A more elaborate kind of blanc-mange, made of whipped cream with  $\frac{1}{2}$  oz. gelatine, dissolved, to each quart; variously flavored and combined. (*See Bavarois.*)

**BAVAROIS (Fr.)**—Bavarian cream. **BAVAROIS A LA PRASLIN**—Bavarian cream flavored with almond nougat pounded to a paste for the purpose. **BAVAROIS AUX PISTACHES**—Green Bavarian made with pounded pistachio nuts and almonds, colored with spinach juice. **BAVAROIS AUX FRUITS**—Bavarian served with compote fruit. **BAVAROIS AUX POMMES**—Puree of apples with whipped cream, set with gelatine, flavored with maraschino. **BAVAROIS AUX POIRES**—With pears instead of apples. **BAVA-ROIS GLACE**—Frozen Bavarian.

**BAY LEAF**—Used constantly, but in small quantities for boiling in soups and sauces. It imparts a flavor like that of plum kernels; is the leaf of a species of laurel; grows wild in parts of the South, plentiful in Florida. Sold in a dry state at the drug stores; cost very little.

**BAY RUM**—Rum flavored with bay leaves. Is one of the principal articles of manufacture and export of some of the West India islands. It is used in various drinks, punches, etc., and as a toilet requisite, particularly for the hair. Home-made bay rum is prepared by procuring rum in its uncolored state; to every gallon 100 bay leaves, freshly gathered and bruised in a mortar, are added; steeped for 10 days with occasional agitation of the cask; allowed to settle, and drawn off.

**BEANS**—The varieties are extremely numerous in this country, the choice sorts being Lima beans shelled green, white wax stringless beans and green string beans of successive varieties from early to

## BEA

late. The Lima bean does not grow in England except as a climbing plant needing a hot and lengthy season to mature it. Kidney beans, French beans and *haricots verts* are our string or snap beans, the kidney beans being the dwarf early kinds. French or string beans are kept green while cooking by being plunged into boiling water containing salt and very little soda or borax; boiled with the lid off, drained as soon as done and plunged in cold water and kept till wanted to warm up in the various sauces. They are nearly always shred lengthwise, not snapped across. **STRING BEANS A LA VERZ**—Cooked in salted water, drained, put into a saucepan with butter, salt, pepper, nutmeg; white sauce and lemon juice. **HARICOTS VERTS A L'ANGLAISE**—String beans boiled, drained, shaken up with butter and chopped parsley. **HARICOTS VERTS SAUTES**—Drained and simmered in butter, salt, pepper, parsley. **HARICOTS VERTS A LA MAITRE D'HOTEL**—Stewed string beans in white parsley sauce. **HARI-COTS VERTS AU BEURRE NOIR**—Butter browned by frying, beans *saute* in it, salt, pepper, vinegar. **HARICOTS PANACHES A LA MAITRE D'HOTEL**—String beans and white beans mixed in white pars-ley sauce. **HARICOTS BLANCS A LA MELLE** Are navy beans seasoned with marrow. **HARICOTS BLANCS AU BEURRE DE PIMENT**—Navy beans with minced red pepper in butter. **HARICOTS BLANCS AU JUS**—Are served with gravy. **HARICOTS ROUGES A LA BOURGUIGNONNE**—Are red (shelled) beans, cooked in meat stock with wine, herbs and onions. **CREAM DE HARICOTS VERTS**—Is soup made by passing cooked string beans through a seive, adding cream and soup stock. **POTAGE A LA CONDE**—Is a soup of white beans. **STRING BEANS WITH BACON**—The popular style, bacon cut dice mixed with the beans.

**BEAR MEAT**—Is eaten by nearly all people where it can be obtained, although viewed with prejudice by many who meet with it for the first time. The meat is like pork, but darker; generally it is very fat. When objectionable eating it is the meat of an old animal. The best is the flesh of the bears which commit depredations in the cornfields of sparsely settled regions, where they grow very fat on corn and fruit. Young black and brown bears are preferable for meat, though the grizzly is eaten as well, but has a rank smell and flavor. The butcher in any western town can sell such bear meat as he may secure a third higher price than beef; and in the cities as a curiosity it brings a high figure. A bear weighing 450 lbs. was cut up in a London restaurant recently, and a trade journal says: "This fine specimen of the ursine family having found its way to the kitchen, the bill of fare duly announced *Jambon d'ours a la Lithuanienne* and *Pattes d'ours* (bear's paws) *a la Muscovite*. We dropped in for a slice of roast bear ham, and found it decidedly 'gamey,' but by no means unpalatable, the flavor somewhat resembling that of venison. Currant jelly, by the way, would have been a fitting accom-

## BEC

paniment. We have before us Christmas bills of fare of the Galt House, Louisville, and Lindell Hotel, St. Louis, and under the head of game we find 'roast cub bear with chestnut dressing' and 'saddle of Rocky Mountain bear with currant jelly'."

**BEARD OF SHELLFISH**—The mussel has a beard-like filament by which it hangs to the rocks, and it must be removed after cooking before the fish is taken from the shell. The oyster has no such beard, but when it is directed to beard oysters the part intended is the gristle by which it adheres to its shells. Some, however, will pull off the fringe, which are the oyster's gills, for no good reason. But the gristly part is really dry and tasteless, and when choice patties, etc., are to be made, they are the better if that part is removed.

**BEARNAISE** (*a la*)—Dishes so entitled have generally bearnaise sauce served with; otherwise it means in Swiss style.

**BEARNAISE SAUCE**—Named from King Henry "the Bearnaise" or his Swiss home. Made of 4 tablespoons white wine vinegar, 2 spoons chopped shallots stewed in it, 2 spoons beef extract, 6 egg yolks; stirred over fire till begins to thicken, removed to side and  $\frac{1}{2}$  lb. butter added, little at a time, with occasional drops of water; strained, and chopped parsley, chervil, tarragon and red pepper added; served with fillet steaks, chops and fish. It is bright yellow, like butter, speckled with green.

**BEATEN BISCUITS**—Specialty of Virginia and adjoining states. A trade journal, remarking upon the difficulty of striking anything new in the biscuit line, says: "The widow of a well-known Presbyterian divine has had a bright, original idea, and is now making a tidy little fortune out of what are called beaten biscuits. These biscuits are not exactly novel; they are just such dainty cakes as the lady, in more prosperous and happier times, was accustomed to prepare with her own domestic appliances and dignify with the appellation 'home-baked.' The dough seems to have been 'beaten' or whipped up till the biscuits turned out as white as snow, with a delicious golden crust. Many of the wonderfully clever old negress cooks in Tennessee and Kentucky houses, with their black but deft fingers, prepared just such biscuits with a crispness, a color and a flavor that fairly deserved the epithet 'divine.' Mrs. Pratt's beaten biscuits are, however, now all the rage in the latitude and longitude of Louisville." These biscuits are in reality a hot cracker; the dough has the same ingredients in it as ordinary soft biscuits, but not so much powder, and needs must be made up with milk. The special quality is attained by pounding the lump of dough with a wooden maul; a biscuit break would do the same.

**BECASSES** (Fr.)—Woodcocks.

**BECASSINES** (Fr.)—Snipes.

**BECHAMEL**—The Marquis de Béchamel, the rich financier and great epicure, whose cream

## BEC

sauce for turbot and cod has been extolled with grandiloquence by a score historians of the table, including De la Reynière and Ude. The Marquis was at one time *maitre d'hotel* to one of the French kings.

**BECHAMEL SAUCE**—Cream sauce made with seasoned chicken broth reduced to the richness of jelly, with mushroom essence added, poured to the usual white roux of butter and flour stirred together over the fire, and an equal quantity cream added. **FOWLS IN BECHAMEL**, and all meat dishes *a la Bechamel* are simply served with cream sauce. **CODFISH AND TURBOT A LA BECHAMEL**—Are in flakes in sauce resembling our "picked-up fish in cream."

**BECHE DE MER**—The sea-slug or trepang or sea cucumber; a kind of sea caterpillar of considerable importance to the Asiatics, who eat it and trade in it dried. It is from 8 to 15 inches long and

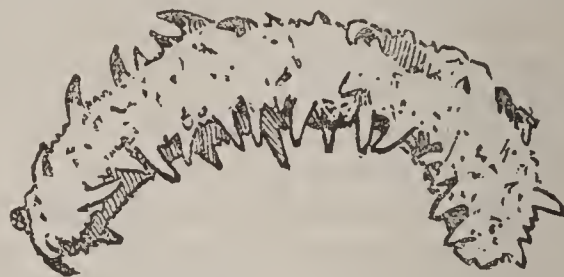

abundant on the Florida reefs. At Key West an enterprising yankee went into the business of making *trepang* (dried *beche de mer*) a few years ago, but he did not succeed in making it pay. (*See Chinese Cookery*.) **BECHE DE MER SOUP**—"With reference to that prime Celestial delicacy, the *beche de mer*, or sea-slug, it may be of interest to describe the method of making the soup as I have seen it prepared by several good Chinese cooks. For, say, ten persons make soup in the ordinary way, of beef, etc. Take two teat fish (sea-slugs) of good quality, or a corresponding quantity of black or red fish, soak in water from 12 to 24 hours, thoroughly scrape and clean from time to time, changing the water as required, as it swells greatly. The result will be a glutinous-looking mass, like lumps of jelly. Boil separately for five or six hours; take out and cut or mince up very fine. About a quarter of an hour before serving add this to the soup and let it boil. There must not be any vegetables. Mince or egg balls are a desirable addition, also sherry, etc., to taste. This gives a body to the soup, which, if left over, will be almost a jelly when cold. I believe if the *beche de mer* were understood it would be used all over the world, especially for invalids, as it is very strengthening, and, although anything but nice-looking in its dry state, it is a very delicate article of diet when properly treated. It makes a splendid addition to beef tea, and I would call the attention of medical men to this fact. In the form of soup it is frequently used in the clubs and leading hotels in Melbourne and Sydney."

**BECFIGUE** (Fr.); **BECCAFICIO** (It.)—Fig-

## BEE

picker; a little bird closely resembling the American rice bird, considered as great a luxury and is cooked in the same way

**BEEFSTEAK ORIGINATION**—Brother Johnathan and John Bull have to thank Lucius Plaucus, a Roman senator, who was commanded by the Emperor Trajan to act as one of the menial sacrificers to Jupiter. In the process of flesh-roasting one of the pieces fell off the altar, and in order to restore it Plaucus burnt his fingers, thrust them into his mouth, and whilst scorning the office he was set to perform, made up for his coercion by devouring every morsel; he thus deluded Trajan, defrauded Jupiter, and invented the beefsteak.

**BEEF**—The progress of the times, rapid transit, large slaughtering and packing operations, wholesale methods of preserving meat both raw and cooked, the utilization of every part for its best purpose and the absence of the old methods and necessities of pushing off parts of the carcass to get rid of them, and also the higher development of the hotel and restaurant systems, have all tended to make changes in the methods of cutting up beef and lessened the significance of the names of joints and cuts as they used to be. The fillet is now a separate cut and can be bought of the packers by the hundred or thousand pounds; the thin flank is not offered for sale; the packers put it to good use as canned corn beef. The summer hotel can have rib roasts, first choice or second choice as ordered delivered from the packing houses, all ready, with the bones removed, the meat coiled up and bound around, skewered, ready for putting in the oven, and not only that, but can have them sent wrapped in paper and in a frozen condition from a great distance. Loins of beef, either short or long, either first choice meat or seconds, can be bought close trimmed in the same accommodating manner, divested of the kidney fat, which the packers use profitably in the form of butterine, and without any surplus bones, for the packers dispose of some of them for various uses in the arts, and the rest for fertilizers. **COTES DE BŒUF A LA BROCHE**—Roast ribs of beef. **ALOYAU A LA BROCHE**—Roast sirloin of beef. **ALOYAU DE BŒUF A LA PROVENCALE**—Sirloin larded, spread with a high-flavored stuffing of marrow, anchovies, garlic, etc.; roasted and served with piquante sauce. **ALOYAU BRAISE A LA GODARD**—Top sirloin garnished with slices of sweetbreads, mushrooms, truffles, etc.; in the reduced wine braise of the beef. **ALOYAU BRAISE A LA ROYALE**—Top sirloin larded and braised. **A LA PRINTANIERE**—Served with young vegetables. **A LA PORTUGAISE**—With glazed onions and sauce. **FILET DE BŒUF AU JUS D'ORANGE**—The tenderloin served like duck with orange sauce. **FILET DE BŒUF A LA NAPOLITAINE**—Larded, marinaded, braised, served with Napolitaine sauce, of horse-radish, ham, wine, jelly and brown gravy. **FILET DE BŒUF A LA BOHEMIENNE**—Tenderloin larded, marinaded by steeping in oil

## BEE

with vegetables and aromatics, braised or roasted, served with fried potatoes, olives, pickled mushrooms and onions in poivrade sauce. **ROUELLE DE BŒUF AU FOUR**—Round of beef spiced and baked with water and fat in a covered pot. **NOIX DE BŒUF BRAISEE**—Chumps of beef braised. **PIECE DE BŒUF GARNIE A LA FLAMANDE**—Is salted brisket boiled and served with Brussels sprouts. **PIECE DE BŒUF A LA ST. FLORENTIN**—Top sirloin rolled, roasted, seived with Robert sauce. **COTES DE BŒUF BRAISEES A LA PUREE DE TOMATOES**—Beef with tomato sauce. **BŒUF HOLLANDAISE**—Is smoked beef boiled. **ROSBIF A L'ANGLAISE**—Roast beef with Yorkshire pudding and horse-radish. **PATE DE BŒUF AUX POMMES DE TERRE**—A pie of minced beef and mashed potatoes with a crust of mashed potatoes. **BIFTECK A LA FRANCAISE**—Broiled steak with French fried potatoes. **PORTERHOUSE OR FILLET STEAK A LA BEARNAISE**—Steak broiled and served with Bearnaise sauce over or around. **TENDERLOIN STEAK A L'HOTELIERE**—Steak fried in butter, gravy made in the pan with cream sauce and essence of beef. **TENDERLOIN STEAK WITH OLIVES**—Steak fried in oil, gravy made in the pan with espagnole and wine; stoned olives added. **TENDERLOIN (OR FILLET) STEAK WITH MUSHROOMS**—Steak fried in butter or beef fat, gravy made in the same pan of espagnole with Madeira and mushrooms. **TENDERLOIN (FILLET) STEAK A LA MIRABEAU**—Steak broiled, basted with oil, Mirabeau sauce of garlic, white sauce, parsley, lemon and beef extract. **FILET DE BŒUF A LA MAITRE D'HOTEL**—Tenderloin steak with butter, mixed with chopped parsley, and lemon juice spread over it; fried potatoes around. **FILET DE BŒUF A LA CHATEAUBRIAND**—Thick fillet steaks with extracts of beef, butter, parsley and lemon for sauce. **FILET DE BŒUF A L'ITALIENNE**—Thin steaks floured and fried brown, served in brown Italian sauce. **ESCALOPES DE BŒUF A LA REFORME (club)**—Thin tenderloin steaks, each one between two slices of bacon, breaded, with chopped ham mixed with the bread crumbs, and fried; served with reform sauce of poivrade and harvey sauces, port wine and currant jelly. **ESCALOPES DE BŒUF A LA NEMOURS**—Thin fillet steaks covered with forcemeat and slices of ham, put together in pairs, breaded and fried; served with white sauce. **ESCALOPES DE FILET DE BŒUF A L'OSTENDE**—Spread with thick white sauce containing chopped oysters and onions, in pairs, breaded and fried; brown sauce. **GRENADINE DE FILET DE BŒUF A LA FINANCIERE**—Thin tenderloin steaks larded, cooked in mirepoix and served in the sauce with financiere garnish. **TOURNEDOS A LA SAUCE POIVRADE**—Slices of cooked fillet dressed in a crown alternately with fried slices of bread of the same size; poivrade sauce in the center. **ENTRECOTES DE BŒUF A LA BORDELAISE**—Thick rib steaks broiled; bordelaise sauce and pieces of beef marrow. **BŒUF EN SAUCISSONS**—Very thin slices of beef rolled up like sausages with forcemeat inside, baked in a covered pan; served with the sauce. Other cuts

## BEE

and different parts and ways of cooking may be found under the proper letters. **BEEF RISSOLES**—Minced beef, either raw or cooked, or both mixed; with sausage seasonings and fat, or crumb of bread to make it cohesive, is rolled into sausage shapes and then rolled up in a thin covering of pie paste, egged over and baked.

**BEEF SOUPS**—Several varieties having beef for the stock or principal ingredient, or having dice-cut beef in them.

**BEEFSTEAK PUDDING**—A boiled meat pie. The English make puddings of snipes, partridges, and every kind of meat by lining a deep bowl or mould with suet short paste, placing in the beefsteak or birds with seasoning additions of mushrooms, onions, cayenne, salt, aromatics, sauce and water; cover the top with a sheet of paste; tie a cloth over and boil for 3 or 4 hours.

**BEEFSTEAK PIE**—Similar to beefsteak pudding, baked. **SAUCISSON BEEFSTEAK PIE**—Specialty of a London restaurant. Started like the French *bœuf en saucissons* named above. Chopped cooked game or other meat seasoned with aromatics, rolled up in shavings of steak to size of corks; these placed in layers in deep pie dish with mushrooms, onions, etc., between. Mussel or oyster liquor for special seasoning; gravy added, top crust and baked.

**BEEF TEA**—Is made best of minced raw beef in cold water set in a jar or other vessel surrounded by boiling water, but never allowed to boil, which would coagulate the albumen and make the liquor less nutritious. Some physicians recommend a raw beef tea, the beef scraped into cold water only. Liebig's extract of meat is beef tea in a concentrated form, only needs diluting to be ready for use.

**BEEF TEA JELLY**—Strong beef tea or extract of meat with 3 oz. of starch or 4 oz. of arrowroot stirred in at boiling point; taken off the fire and made cold. For invalids to change from beef tea.

**BEEF A LA MODE**—Is not the same as the à la mode beef of a former page. This, either larded through with strips of fat bacon or has such strips rolled up in it, is braised with herbs and wine and cut in slices across the larding when done. There are at least three or four styles of the dish, depending only upon what is served with it; as *Allemande*, with raisin sauce; *Anglaise*, with vegetables; *Française*, with a ragout of mushrooms and quenelles in wine sauce.

**BEEF, THE "BARON" OF**—"In accordance with the custom the Queen's table was furnished at Christmas with a splendid 'baron' of beef, weighing about 300 lbs., which was flanked on either side by a boar's head and a woodcock pie. The huge joint, as is customary, was roasted at Windsor Castle and thence despatched to Osborne. By the way, why the 'baron' of beef has so lordly a title is not quite clear. As the joint consists of the beast's two sirloins—or 'Sir Loins,' as some people spell

## BEE

the word—not cut asunder, the name may possibly have been given on the principle that one baron is equal to two knights."

**BEEF EATERS**—"Beef and mutton was the diet that bred that hardy race of mortals who won the fields of Cressy and Agincourt. I need not get up so far as the history of Guy, Earl of Warwick, who is well known to have eaten up a dun cow of his own killing. The renowned king Arthur is generally looked upon as the first who ever sat down to a whole roasted ox, which was certainly the best way to preserve the gravy; and it is further added that he and his knights sat about it at his round table, and usually consumed it to the very bones before they would enter upon debate of moment."

**BEEFSTEAK, HOW TO COOK**—It requires courage in the light of our knowledge and almost daily experience for one to assert that there is no reason why every beefsteak that is put on the table should not, so far as cooking is concerned, approach the ideal steak. "Subscriber" writes from far Louisiana to know how his cook may be instructed to give him a good beefsteak. A member of my own family has brought the cooking of this article of food to what we consider perfection. The first requirement is not so much a tender and juicy steak, though this is always to be devoutly desired, but a glowing bed of coals, a wire grid-iron—a stout one, with good-sized wires—a double one, so that you can turn the steak without touching it. The steak should not be pounded; only in extreme cases, when it is cut too thick and is "stringy." Attempt nothing else when cooking the steak; have everything else ready for the table; the potatoes and vegetables all in their respective dishes in the warming closet or oven, with the door left open a little way. From ten minutes onward is needed to cook the steak. The time must depend on the size, and you can easily tell by the color of the gravy which runs from the steak, when gently pressed with a knife, as to its condition. If the master of the house likes it "rare done," when there is a suspicion of brown gravy with the red, it will be safe to infer that it is done enough for him; if, as is generally the case, the next stage is the favorite one, remove the steak from the grid-iron the instant the gravy is wholly of a light brown. Remove it to a hot platter, pepper and salt to your taste, put on small lumps of butter, and then for two brief moments cover it with a hot plate, the two moments being sufficient to carry it to the table. One absolutely essential factor in the preparation of good beefsteak is that it must be served at once. If "Subscriber" can impress it upon his cook that she is not to let the steak stand and steam while she is doing other things, he will be likely to receive his reward for so doing. If he can inspire his cook with a desire to excel, if he can induce her to believe that it is worth while to take pains, he will do an even more important work than to produce a delicious steak. I often think that a good

## BEE

cook must belong to one or two orders—she must be a Christian of great conscientiousness, or a person of abundant culture, whose sole delight is to do well and with thought whatever is undertaken. **THE SECRET OF GRILLING**—While busy at the grill, showing everyone present how it is done to a turn, the following query has often been put to the writer: “Will you impart the secret how to grill? for my cook is a very good cook, but she cannot produce me a satisfactory chop or steak.” Of course, every cook in a private family does not prefer the frying-pan to the grid-iron, because it is more convenient. Oh no! I am not going to say anything of the kind. Some of my querists have gone so far as to have an apparatus fitted up after the fashion of the well-known type of the public grill, but with no better result. What is to be done? I will tell you. The operation is perfection, for it is simplicity itself, and simplicity is perfection. “Turn, turn, turn away; that’s it, boy” (for I was a boy once); “you cannot turn them too often,” so said my tutor, old Tom Brown, the celebrated grill manipulator of the then universally known Joe’s Chop House, of Finch Lane. It is impossible to give any stated time for grilling anything; there is but one method of judging when the articles are properly cooked, that is, by bringing into play what the illusionist finds indispensable, viz.: the sense of touch. Strange as it may appear, these two arts go readily hand in hand. Now, reader, all you have to do is to practise.

**BEER SOUP; BIER SUPPE** (Ger.)—(1)—A traveler, who says he has often partaken of it in country houses and at the beer houses in the cities, and that it is eaten cold, at least in summer, describes it as half beer, half water, with bread crumbs, currants and lemon peel stirred up in it. (2)—A hot beer soup, called German, is the same as English ale posset, being 2 qts. mild beer simmered with sugar and spices and poured upon 6 beaten eggs and ½ pint cream; all whisked till frothy and poured upon a slice of toast in a bowl. (3)—Bread and caraway seeds boiled in mild beer and poured upon beaten eggs; hot enough to thicken, but not to curdle them.

**BEIGNET** (Fr.)—Fritter. **BEIGNETS SOUFFLES**—Fritters which puff up hollow; also called aigrettes; they are à la vanille when flavored. **BEIGNETS A LA DOMINIQUE**—Savory, made of a delicate salpicon or mince of chicken, with aromatic seasoning in flattened balls, dipped in oil-and-wine fritter batter and fried; served with chopped truffle and tongue in glaze. **BEIGNETS D’ABRICOTS A LA CHARTRES**—Apricot fritters. **BEIGNETS AUX FLEURS D’ORANGE**—Flavored with orange flower water. **BEIGNETS EN SURPRISE**—Apples partly hollowed, the stalks left on, soaked in brandy, filled with apricot jam, dipped in batter and fried. **BEIGNETS AU MAIZENA**—Custard or cream fritters made with corn starch. **BEIGNETS A LA PORTUGAISE**—Rice croquettes with marmalade in the center. **BEIGNETS AUX CON-**

## BER

**FIGURES**—Fritters served with preserve. **BEIGNETS A L’ALLEMANDE**—Also called Bismarck’s; a spoonful of jam between two thin flats of light dough; allowed to rise, then fried. **BEIGNETS A LA PRUSSIENNE**—Apple turnovers (*which see*) fried instead of baked. **BEIGNETS DE FLEURS DE SUREAU**—Fritters of sprigs of elder flowers. **BEIGNETS D’ORANGES**—Orange fritters. **BEIGNETS DE CINTRA**—Thin round slices of cake soaked in cream, flavored with brandy, floured and fried. **BEIGNETS A LA CREME**—Custard fritters; pieces of custard made with flour or starch firm enough to cut when cold, dipped in batter and fried. **BEIGNETS AUX CONFITURES**—Marmalade fritters; thin sandwiches of cake and jam dipped in batter and fried. **BEIGNETS A LA CHANTILLY**—Cream cheese fritters, made of sweet cream curd, flour, eggs, sugar and wine, dropped by small spoonfuls in hot lard and fried. **BEIGNETS D’ABRICOTS A L’EAU DE VIE**—Apricots and brandied bread in batter. **BEIGNETS DE PECHES A LA ROYAL**—Peach fritters. **BEIGNETS DE FRAISES A LA DAUPHINE**—Strawberry fritters.

**BENGAL CHUTNEY**—A sour-sweet-savory jam, used as a relish with meat, game, etc.; made of 1 lb. each tamarinds, sultana raisins, tomatoes, apples, ginger, moist sugar; ½ lb. red chillies; ½ lb. each garlic and onions; 4 qts. strong vinegar; rind and juice 8 lemons; ingredients pulped or minced. Kept a month in warm place to ferment; tied down in small jars; served sometimes with curried fish. (*See Indian chutney.*)

**BERKELEY PUDDING** (Fr.-Eng. specialty.)—A bread-suet pudding boiled in a mould; made of 1 lb. bread crumbs, 1 lb. suet, 1 lb. moist sugar; 4 eggs, 1 glass ale, juice 2 lemons. Boiled 2 hours; served with a sabayon sauce.

**BEETS**—Best for table are the blood beets; sugar beets, nearly white inside, are as good for serving in sauce hot, not so good for ornamental purposes. Favorite ways of using them: **BEETS IN BUTTER**—Young garden beets boiled quite tender in their skins, peeled, sliced; salt and plain butter. **BEETS IN SAUCE**—Butter sauce with vinegar in it; little sugar and salt. **BEETS IN VINEGAR**—Cold blood-beets sliced and covered with vinegar; called also pickled beets. Will keep a week if cool. **BETTERAVES A LA CREME**—Cut up in dice in a white sauce. **BETTERAVES A LA POITEVINE**—Cut in slices like sections of an orange; after boiling, served in brown sauce with onions and spices. **BETTERAVES A LA CHARTREUSE**—Yellow beets sliced after boiling, a slice of onion between two slices of beets; dipped in batter and fried. **BEET SOUP** (*See barszcz.*) **BEETS IN SALADS** (*See salads.*) Beets are largely used for decorating dishes.

**BERLINGOTS DE ROUEN** (Fr.); **BERLINGOZZI** (It.)—Stick candy.

**BERLIN PANCAKES** (Ger.: *Berlinen Pfannkuchen*)—Are known in this country as *Bismarcks*; in France as *Beignets a l’Allemande*. They are

## BET

rich yeast-raised doughnuts, having a spoonful of preserve inside; are nearly round. Like all doughnuts they are fried in lard and rolled in sugar when done. In Poland they have the same by the name of *Ponskis*.

BETTERAVE (Fr.)—Beetroot; beets.

BEURRE (Fr.)—Butter. BEURRE D'ANCHOIS—Anchovy butter. BEURRE DE HOMARD—Lobster butter.

BIBINCA DOSEE—This is the name of a famous Portuguese pudding, well worthy of a trial by way of variety. Scrape two coconuts finely; pour boiling water thereon, sufficient to yield a breakfast-cupful of strong infusion, after soaking for a quarter of an hour, and set it aside. Prepare a syrup from three-quarters of a pound of sugar; mix into this half a pound of rice flour or rizine, finely sifted, and the coconut infusion. Boil over a brisk fire with constant stirring, until it thickens. Pour into a buttered dish, and bake to a light-brown color.—*Note*—There must be 3 pints of liquid to that amount of rice flour.

BIGARADE—Name of an orange. Orange sauce for ducks, etc., made by cutting the rind of sour oranges in fine shreds, parboiling, adding them and the juice to brown sauce or gravy.

BIJOUTIER (Fr.)—Name facetiously applied to dealers who gather up cooked food from the clubs and private houses for re-sale. The word legitimately means jeweler. The *bijoutier* pays so much a month to the *chefs*, basing his calculations after a week's trial, and sells the broken victuals in assorted platefuls in the public market.

BIRD PEPPER—The small chilies or capsicums of which ground cayenne is made.

BIRDS' NEST SOUP—The birds' nests from which the far-famed soup is made are built by a species of swallow which abound on the coast of Java, Ceylon and Borneo, and practically consists of a gelatinous substance obtained from marine plants. The nests are boiled either in chicken broth or in milk, with almonds. The result very much resembles vermicelli soup, but is more costly.

BISCUITS—Crackers in England and France are called biscuits; in the United States they are a shortened kind of rolls or breakfast-bread, usually eaten warm; name from two words signifying twice baked, *i. e.*, dry. Made of flour—all or any kind—with baking powder, salt and shortening, or with flour, buttermilk, salt and soda. Biscuits are the oldest form of bread. At what time of man's history the lightening of dough by fermentation was first adopted no one, of course, knows. It is, however, certain that cakes made of nothing but meal and water is much older. Fragments of unfermented cakes were discovered in the Swiss lake dwellings which belong to the neolithic age—an age dating back far beyond the received age of the world. This is the earliest instance of biscuits as yet discovered, for biscuits are merely unfermented bread.

## BLA

BISCUITS DE RHEIMS—French specialty—eaten with champagne. It is a variation of lady fingers or Naples biscuits dried. Made by adding and beating 4 eggs to 12 ounces sugar, making warm while beating; then cool; 8 oz. flour, 1 oz. arrowroot, lemon rind for flavor; baked like finger sponge cakes; dry in slow oven.

BISCUIT GLACE—Has two meanings which causes mistakes. (1)—Savoy or sponge cake iced or glazed with sugar is a *biscuit de savoie glace*. (2)—Ice cream of any kind in a mould; especially small biscuits or cakes of ice cream in paper cases are meant, as they were the original "cakes of ice"—*biscuits glaces*.

BISQUE—A paste or puree. POTAGE BISQUE AU RIZ is fish soup with crayfish tails and rice. BISQUE OF CRAYFISH—Soup of rice and crayfish, in veal broth; the crayfish partly fried with butter, onion, carrots, salt pork; broth added, boiled an hour; tails of crayfish saved, boiled rice and crayfish hulls pounded through a strainer and added to the soup with crayfish tails and parsley. This is the soup which some humanitarians of northern France moved against because the crayfish are thrown into the hot fry alive. BISQUE OF LOBSTER—Soup of lobster and rice; first fried, then boiled and pounded lobster meat and shell, with rice, passed through seive, and soup thickened with it; finished with butter, sherry and squares of fried bread. BISQUE OF CRABS—Made same as bisque of lobster; crabs boiled first, cut up, fried with onions, celery, salt pork, stock added; boiled an hour; rice boiled, and puree of rice and crabs thickens soup; sherry, etc., to finish. BISQUE OF OYSTERS—A white soup like cream sauce, the oysters after boiling rubbed through a seive, milk and cream with the broth and oyster liquor, and butter roux to thicken; slight flavoring of bay leaf and mace. BISQUE OF PLOVER A LA ROSINI—Plovers braised in port wine stock an hour, the meat then pounded fine and passed through seive. Semolina boiled in broth, also passed through seive, and plover stock thickened with them. Served with grisini bread. (*See grisini*.) BISQUE OF PARTRIDGE A LA DAUPHINE—The meat of roast partridges, chestnuts and white bread made into a puree with broth and port wine.

BISQUE ICES—Ice creams containing a paste, not too finely strained—of fruit, preserved ginger, chestnuts, walnuts, almonds and the like are named accordingly, as BISQUE OF PINEAPPLE, made by adding to ice cream some pounded, preserved or stewed pineapple.

BLACKBERRY—Uses of: DRIED BLACKBERRIES—One bushel of fruit makes 10 pounds dried. BLACKBERRY PIES—Great favorite in the season. (1)—Made by heaping the berries raw in a pie crust sugaring, and covering same as apple pies. (2)—Berries and thin-sliced apples mixed together, sugared, covered and baked slowly. (3)—Blackberries stewed, or taken from cans, and little sugar

## BLA

added; baked with top crust, or in open pies, with strips over. (4)—Pies, English style, in deep earthenware dishes, a tea cup *inverted* in the dish; all around filled with berries and sugar, short crust; the cup draws in the juice and is found to be full when lifted, and besides it holds up the center of the crust. **BLACKBERRY ROLY-POLY**—Short paste or biscuit dough rolled thin, covered with berries or with blackberry jam, rolled up in a cloth (like a huge bo-togna), ends and middle secured, boiled an hour or more; may be baked as well; served with butter and sugar. **BLACKBERRY SHORTCAKE**—Same as strawberry, raspberry, etc. **BLACKBERRY MERINGUE**—Ripe berries with sugar spread upon a thin sheet of cake, meringue or frosting, same as for lemon pies, spread upon the berries; baked a little; cut out in squares. **BLACKBERRY COBBLER**—Same as cherry, peach, etc. **BLACKBERRY DUMPLINGS**—Half a cup of berries inclosed in paste, like apple dumplings. **BLACKBERRY PUDDING**—Berries mixed in bread puddings, boiled or baked same as raisins are used. **BLACKBERRY BATTER PUDDINGS**—Batter thin in a baking pan, like Yorkshire pudding; berries strewed over the surface; baked. **BLACKBERRY SYRUP AND CORDIAL**—(See drinks.) **BLACKBERRY WINE**—(See wines.) **BLACKBERRIES AS TABLE FRUIT**—Washed and drained, served in fruit saucers or glass dishes with broken ice scattered over the top, ice only placed at the time of serving. Powdered sugar served separate.

**BLACK-COCK**—Kind of grouse—Scotch and English—not very highly esteemed for table; are hung a long time to make them tender; roasted and stewed with wine in the sauce. **COQS DE BRUYERE A LA ROYALE**—Black-cocks larded, braised, and served with a white sauce and small rissoles of game. **COQS DE BRUYERE A LA ROB ROY**—Black-cock stuffed, roasted with sprigs of heather and whisky, and served with butter sauce.

**BLACKFISH**—A black perch, esteemed as a pan fish, fairly plentiful in the southern markets. Smaller and blacker than the black bass; flesh is much like it.

**BLACK STRAP**—A tippie of a mixture of rum and molasses; a souvenir of old colonial days and of the hard cider campaign.

**BLACK PUDDINGS** (*Boudins Noir*)—A kind of sausage of pig's blood mixed with dice-cut pieces of pork fat, onions and sometimes a little cooked barley or rice; all seasoned with aromatic salt, filled into skins and boiled. They are eaten either cold or split lengthwise, and broiled or fried. They are, or used to be, universally eaten on Christmas Eve by the French middle classes. The Flemish way is to eat them with baked apples. Edmond About used to tell of a good monk who once indulged in a ham omelette on a Friday, when a thunder storm came on, and he threw the uncanonical delicacy out of the window, murmuring: "All this noise about an omelette!" And of another, being rebuked for eating

## BLU

a black pudding on Good Friday, replied with: "Why not? The pudding is deep mourning!"

**BLANCHAILLES**—The French coined word for that small minnow-like fish, the famous English whitebait.

**BLANCHI**—To scald. It means to whiten, literally. To blanch almonds is to scald and peel them; to blanch parsley, chives, shallots and herbs is to plunge them a minute in boiling water that they may not go into the sauce raw.

**BLANC MANGE**—Literally white-food. Cream or milk set with gelatine, an ounce to a quart, sweetened and flavored. When quite cold it is solid enough to be turned out of a mould and keep its shape on the table.

**BLANQUETTE**—A sort of general designation for any dish of white meat having a white or creamy sauce and no other special flavoring or characteristic. There are blanquettes of veal, lamb, fowl and quail, but not of beef or dark meats. **BLANC DE VOLAILLE AUX CONCOMBERS**—White meat of fowl, with cream sauce and cucumbers. **BLANQUETTE D'AGNEAU**—Small round slices of lamb and of ham or tongue, with white sauce, parsley; served in a baked shape of rice or bordered with fried crusts. **BLANQUETTE DE RIS DE VEAU AUX TRUFFES**—Sweetbreads cut in round slices, with slices of truffles in cream-colored sauce, made of broth, cream, butter and yolks of eggs.

**BLOATERS**—Often called Yarmouth bloaters; are smoked herrings, the town of Yarmouth having a special fame for them. The largest herrings are selected and mild-cured; not for long keeping. Their fatness causes them to bloat or swell while in the smoke, hence the name.

**BLONDE**—Culinary term; white broth. Soup liquor in which is no roasted or fried or dark-colored meats, though it be well seasoned otherwise. It is merely for use in rich cooking instead of hot water. **BLONDE DE VEAU**—Veal broth.

**BLUEBERRIES**—Also called huckleberries and whort'berries; grow wild in the eastern and middle states. Used in all ways the same as blackberries.

**BLUE-FISH**—Is split open same style as mackerel—down the back—and broiled. **BLUE-FISH, WHITE WINE SAUCE**—Cooked in pan with buttered paper over, pan containing white wine, broth, onion and aromatics; thickened when fish is done with flour-and-butter and egg yolks. **BLUE-FISH, MATELOTE SAUCE**—Similar to the preceding; matelote is fish stew, and contains garlic, onions, mussels, anchovy essence, red pepper, lemon juice. **FILLETS OF BLUE-FISH A LA DUXELLES**—Boneless sides spread with sauce, breaded and fried, served with Duxelles sauce round in the dish. **BLUE-FISH IN SEASON**—From May till November.

**BLUE POINT OYSTERS**—Small, but plump oysters for serving raw; first so named from a par-

## BOA

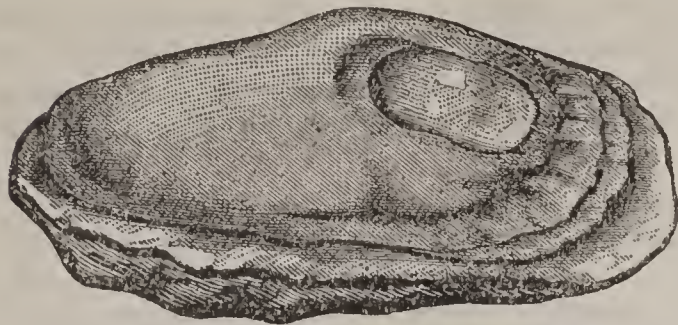

ticular locality near New York; now bred and cultivated to this requirement in various places.

**BOA**—The late Mr. Frank Buckland recommended boa-constrictor for its white and firm flesh, "tasting something like veal;" but it is to be observed that this enthusiastic naturalist's opinion is founded only on the fact that he "once ate" a sample. Possibly the extreme scarcity of boa-constrictor flesh in the markets was the cause of his subsequent abstinence.

**BOAR'S HEAD**—There has been more ceremoniousness in the manner of serving the boar's head in olden times than with anything else save the peacock, and the survival of some old customs still makes this a more important dish than it otherwise would be. It was in accordance with a custom, ancient even then, that king Henry II himself served the boar's head to his son on the latter's coronation; the procession was preceded by trumpets. The hog's head is boned, stuffed, boiled, pressed in shape, the cloth bandage taken off and the head is decorated fancifully, sometimes to imitate life, with spun sugar for bristles, sometimes made gay with colored jelly and flowers.

**BOISSON**—The economic Norman usually dilutes cider with water, and it is then sold and bought as *boisson*. *Boisson* means drink generally elsewhere; in Normandy it has the meaning of diluted cider.

**BOIVIN STEAK**—*Entrecote boivin*; restaurant specialty. Steak broiled, sauce poured over made of some spoonfuls of gravy simmered down with leaves of tarragon, and crushed pepper, meat glaze and butter roux added; strained.

**BOMBE**—Ices in a mould; an outside coating of one kind, filling of another. **BOMBE AUX FRUITS**—Mould lined with chocolate ice cream and center filled with tutti-frutti. **BOMBE A LA SOUVERAINE**—Mould lined with white almond ice (milk of pounded almonds), filled with tea ice cream. After filling packed in ice.

**BOMBAY TOAST**—Anchovy butter with equal amount of raw yolks stirred over fire till scrambled, spread on fried bread.

**BONIFACE**—The term applied to landlords; originates from a character in a play written by George Farquhar in 1707. Will Boniface was the landlord of the inn. The play had a great run and the name Boniface became a synonym for hotel-keeper thereafter.

## BOR

**BONED MEATS**—The term means *boneless*. Turkeys, chickens, pigs' heads, etc., have the bones taken out before cooking and are called boned turkeys, etc.

**BON**—Good. The French cooks' usual response to an order, instead of the English "very well," or the American "all right."

**BONDINETTES OF GAME**—Minced game of any kind, seasoned, mixed with small proportion of bread crumbs, parsley; egg and broth beaten together to moisten the mince; baked in little paper cases; served with green peas.

**BONITO**—Southern sea fish of the Spanish mackerel family, sometimes found 3 or 4 feet in length; its principal food is the flying fish of southern waters. The flesh has a bluish tinge, and that of the large ones is rather coarse, but firm, and makes good and shapely steaks for broiling. **BONITO A LA PROVENCALE**—Boiled in broth with little flour, wine, onion and parsley in it. Liquor strained, thickened; capers added.

**BON VIVANT (Fr.)**—Good-liver; high-liver; a luxurious eater.

**BORAGE**—A garden herb; balm. A leaf or two at a time is used to top a punch or wine-cup.

**BORAX AND BORACIC ACID**—A borax valley was discovered in California, a dead valley, so-called, or alkali tract, in which was no life; and this proved to be a great, indeed an inexhaustible deposit of borax, and a company was formed to work it. The discoverer found the carcass of a horse there which had died several months before and was still like fresh meat, the boron, boracic acid, or whatever the name of the principle might be, having preserved it. It is said the various useful properties of borax were known to the ancient Egyptians who used it in embalming their dead. They have been well known in recent times, but the material was too scarce to allow the knowledge to be of much use. **BORACIC MEAT PRESERVATION**—A new process of preserving meat consists in injecting a solution of boracic acid into the blood of an animal immediately after it has been stunned, and before the heart has ceased to beat, the whole operation, including the removal of all the blood and chemical fluid from the body of the animal, only taking a few minutes. A demonstration of the effects of this process has been given at the Adelphi Hotel, London. The joints cut from a sheep, which had been hanging for more than seven weeks at the House of the Society of Arts, were cooked in various ways, and those present agreed that the meat was equal to ordinary butchers' meat.

**BORATED FISH**—That is, fish preserved by the boracic acid process, are being sent freely into our markets by the Norwegian curers, and are found to be without taint or sign of putrefaction, while the flavor is by no means deteriorated. The Roosen process of fish preservation by permeation of the



## BOR

tissues by a boracic acid solution under pressure has made considerable headway. Public tests of packages of fish which had been kept in this way for from 2 to 3 weeks, and then cooked, resulted in an entirely satisfactory manner, showing that the preservative agent is most useful for keeping provisions temporarily until they are required for use. **BORAX FOR COCKROACHES**—It having been published with great positiveness that powdered borax would drive away or destroy cockroaches, some correspondents answered that they had not found it so successful. An experimenter tells them that the borax is a sure exterminator, but it is necessary to have it freshly powdered. Says he: "I have the borax pulverized with a glass roller and never use it as it is bought. The roaches do not eat the borax, as many suppose. The way it kills them is this: The fine powdered borax adheres to the membrane of the feet, and the attempt to dislodge it, by striking the feet behind, is what kills them. The borax has to be very fine and fresh. It can be best sown by hand in the places which they frequent." **BORAX FOR CABBAGE AND ONION ODOR**—In answer to a correspondent asking what would allay the smell from boiling green vegetables, a steward of a club replies that he has used borax in the boiling water for years and that it effectually kills the smell, retains the green color better than soda, and is perfectly harmless. **BORAX IN SOAP**—It is a useful ingredient, and where soap is made in the hotel is worth learning the recipes for using. Borax, if bought by the keg, is one of the cheapest substances in store.

**BORDELAISE COOKERY** — Bordeaux has long been renowned as the headquarters of good cheer. Paris may have boasted of a larger number of first-class restaurants, but the best cooks have come from Bordeaux and neighboring towns in Gascony, and the district has for centuries been known as the strong-hold of *la haute cuisine bourgeoise*. The markets of Bordeaux itself are famed for a goodly number of local delicacies. There the *gourmet* can purchase that most succulent little fish, the royan, which some epicures declare to be a twin brother of the sardine, while others hold that it is a cousin-german to a pilchard, and which is caught only in autumn. Then there is the ceps, a kind of mushroom which is cooked in oil; and Bordelaise gourmets further rejoice in the little birds called "mûries," which resemble the Italian "beccafiche," or fig-peckers. As for the ortolans, they are an importation from Agen and the Pyrenees. Touching the cookery of all these good things, some slight amount of mystery attaches to the sauce called "Bordelaise." The most learned authorities in cookery hold that, properly speaking, there is no such sauce as Bordelaise at all, and that what is so called is only a variety of the "sauce Gênoise," and obtained its conventional name on account of the Bordeaux wine which forms one of its principal ingredients. The culinary doctors, however, differ as to the hue of the wine used in making Bordelaise. In

## BOU

Kettner's "Book of the Table" it is laid down that Bordelaise should be made of a good brown sauce—Espagnole is the best—boiled down with a tumblerful of red Bordeaux, with one or two shallots chopped small, and with a clove of garlic well crushed. Jules Gouffe's recipe for the same sauce prescribes so much Spanish sauce boiled down with white Bordeaux wine, either Sauterne or Grave, which must be added chopped and blanched shallots and a teaspoonful of chopped parsley. To add problem to problem and mystery to mystery, there is a well-known dish called *entrecôte à la Bordelaise*, which ostensibly should be fillet steak with Bordelaise sauce. It is nothing of the kind—first, because, strictly speaking, there is no such thing as Bordelaise sauce, and, next, because the entrecôte in question is only a rib-steak grilled in the ordinary way, and served with a piece of cold *maitre d'hotel* butter, into which has been wrought some finely minced shallot. It is possible, nevertheless, that entrecôtes accommodated with cold *maitre d'hotel* butter were popular in the *cuisine bourgeoise*, or cookery of private life, at Bordeaux, long before they found favor in Paris.

**BORDERS OF RICE, ETC.**—(See *Bordure*.)

**BORDURE** [*en*] (Fr.)—Dishes that are served up by making on the platter a border of mashed potato, rice, fine hominy, Jerusalem artichoke, or any such material, and filling the inside with the meat prepared for it, are often named as "Border of Rice," or whatever it is, "garnished with—" whatever rãgout or stewed meat. This making the border, the leading feature is one of the unintelligible technicalities; it arose from the possibility of making the border an ornamental object, a work of culinary art, more to be thought of than the inside filling of meat. **BORDER MOULDS**—There are moulds to be purchased of many fancy shapes, like crowns, tiaras, etc., which are but borders to be filled with various hot border material, as named above, to be turned out like a cake after baking, but more particularly are used to make borders of jelly, of fruits in jelly, *pains*, *cremes*, and salads set with jelly, all to have a hollow or well, to be filled with whipped cream, or salad, after turning out.

**BOUCHEE** (Fr.)—Mouthful. **PETITES BOUCHEES**—Little mouthfuls. **BOUCHEES AU SALPIÇON**—Two rounds of puff paste, with some savory minced meat between, and baked. **BOUCHEES A LA REINE**—Small patties of the vol-an-vent sort, with a spoonful of minced chicken or other meat in sauce for the filling. **BOUCHEES A LA MOELLE**—Small patties filled with marrow and a savory sauce of cream shallots, chives, etc.

**BOUDINS** (Fr.)—Puddings of meat. **BOUDIN NOIR**—Blood pudding or sausage. **BOUDIN BLANC**—White pudding or sausage of veal, bread, etc. **BOUDINS A LA RICHELIEU**—This kind of hot, white pudding of chicken meat is thought to have done more to immortalize the name of Richelieu than the

## BOU

capture of Mahon. First, it is a paste made of breast of chicken, pounded and forced through a seive, seasoned, and, with the addition of a pasty sauce to make it like dough, it is made out like flattened eggs in shape, and poached. Then made cold, part of the inside removed, and the cavity filled with a mixture of lightly fried onion, truffles and mushrooms with butter and gravy; then the orifice covered with the chicken paste, and the surface decorated with truffles made to adhere with white of egg. These may be made in advance of the meal. When wanted, they are simmered in a little broth, not enough to cover; made to shine with a little glaze over the decorated surface, and dished up with a ragout of glazed onions, small quenelles and truffles around. **BOUDINS DE LIEVRE A LA RICHELIEU**—Hare cooked, the meat pounded to a paste with fat bacon and aromatics; made into rolls, breaded and broiled; served with truffle sauce. **BOUDINS DE LAPIN**—White puddings of rabbit; the meat pounded through a seive with aromatics and fat bacon, made into flattened balls, decorated on top, poached, served with mushrooms or truffles in brown sauce. **BOUDIN DE VEAU A LA LEGUMIERE**—Veal forcemeat prepared as for rabbit boudins; a mould ornamentally lined with cut vegetables, the center filled with the prepared veal; steamed, served with brown sauce.

**BOUILLI (Fr.)**—Boiled beef.

**BOUILLON (Fr.)**—Beef broth; also the general name for stock or soup liquor of any kind of meat.

**BOUILLABAISSE**—The provençal fish-stew; is not a very formidable dish to prepare. The cooks of various hotels and restaurants in the southern sea-coast towns of the United States make it two or three times a week as a matter of routine, and are not pinched to the requirement of any particular sort of fish for it. The plentiful and almost boneless red-fish (channel bass) is taken for the foundation and any others may be mixed in sparingly. It is required to have, besides the cut-up fish, oil, white wine, garlic, leeks or onions or both, saffron or tomatoes, red pepper and herbs. The onions, leeks and garlic finely minced are half fried in the oil in a broad saucepan; the pieces of fish put in and the frying continued with a little gentle shaking until the fish is set firm. Then the wine is poured in, perhaps a little water or stock, the pepper, herbs, salt and saffron, and the stewing goes on for an hour without a lid. The liquor or gravy is required to be like thick soup, is either boiled down or thickened with roux, well skimmed, served like a stew, fish and sauce together. The modern tomato is supplanting the ancient saffron in dishes of this class, and the Creole bouillabaisse made with tomatoes is acceptable to everybody. The eminent sample of the highest class of culinary literature appended here will be found edifying reading. It is from the leading journal in the catering trade:

“Bouillabaisse is a fish soup for which the Pro-

## BOU

vençal fishing towns are famous, chiefly Marseilles. Garlic is essential to it, as to nearly all the Provençal cookery; but those who eschew garlic may still obtain from it a good idea of how to concoct a savory fish soup. Thackeray's ‘Ballad of Bouillabaisse’ has given it a great name in England, but most Englishmen find it disappointing. It is a soup to be mightily loved or to be abhorred.

‘This Bouillabaisse a noble dish is—  
A sort of soup or broth or brew  
Or hotch-potch of all sorts of fishes,  
That Greenwich never could outdo;  
Green herbs, red peppers, mussels, saffern,  
Soles, onions, garlic, roach and dace;  
All these you eat at Terré's tavern  
In that one dish of Bouillabaisse.’

“Choose a variety of fish—soles, red mullets, dorys, whittings, flounders, perch—avoiding the oily sorts, as the herring and the eel. The mussels mentioned by Thackeray are a pleasant addition. Reckon from half to three-quarters of a pound for each person to be served. For every pound of fish put a pint of water into a stewpan, a quarter of a pint of white wine, and a tablespoonful of oil. Then, supposing there are four or five persons to be provided for, add two sliced onions, two cloves, two bay leaves, two leeks (the white only, but chopped), four cloves of garlic, a tablespoonful of chopped parsley, a little orange or lemon zest, half an ounce of chopped capsicums, a teaspoonful of saffron (but many tastes crave a whole tablespoonful), pepper and salt. Into this mix the fish, which have been well trimmed as well as cut into pieces, and boil them for half an hour. The Marseillaise declare for rapid boiling on a brisk fire, pointing out that the name ‘Bouillabaisse’ means Bouillon-abaisé—that is, broth rapidly reduced by evaporation. This rule, however, is not always followed. When the soup is to be served, drain the fish and put them on a dish apart, making, spite of Thackeray, a pretty good clearance of herbs and spices. Strain the soup by itself into a tureen, with, it may be, sippets of toast in it. It is more common, but not so good, to serve soup and fish together. Kettner's recipe for the famous Provençal fish stew (as set forth above) differs materially from that adopted at the Hôtel du Louvre et de la Paix, Marseilles, where bouillabaisse is unquestionably cooked to perfection. We are able to give this recipe:

“**RECETTE DE LA BOUILLABAISSE**—Poissons: Rascasse, vives, têterase, rougets, verdeau taché rouge, chapons, macquerau, merlan, anguille de mer, langoustes (petites), cigale, galinette, St. Pierre. N. B.—Le poisson doit être lavé et nettoyé dans l'eau de mer, l'eau douce lui enlève sa finesse de goût.

“Composition: Huile fine, un peu de cognac, un peu de vin blanc, poivre moulu de frais, sel, saffran, oignon, bouquet garni, ail très peu. N. B.—Bouquet se compose de laurier, basilic, sauge, thym, fenouil, persil.

“N. B.—Cuire vivement pendant sept minutes.’

“The rascasse, or têterase, is a reddish fish like a

## BOU

perch, with a similar spiny process on his back. This is the prime fish of the bouillabaisse. Of the remainder, the little red mullet of Marseilles, the mackerel, and the whiting, are well known. The galinette is the gurnard; the St. Pierre is our familiar friend, Mr. John Dory; and the langouste is the sea crayfish commonly seen in London fishmongers' shops. It is believed that in the Mediterranean the langouste is better than the lobster, which is rarely in condition in these southern waters. The *anguille de mer* is an eel caught among the rocks of the Riviera, and the *verdeau* is altogether a remarkable fish; it is like a salt-water pike in the expression of its face and the shape of its body. Its coloring is curious. It is of a metallic greenish blue, not so vivid as that of the fresh sardine, but very bright, and divided like a map by orange lines, which suggest a survival of a sometime mail-clad fish. Any piece of alligator-skin will convey the exact idea of the shape of these markings. The vive is the weaver of English waters."

**BOURIDE A LA MARSEILLAISE**—Fish stewed in wine and water with garlic and other aromatics; yellow sauce made of pounded garlic, lemon juice and egg yolks; the boiling fish liquor strained with it, cooked enough to thicken, but not curdle; sauce poured over slices of bread, fish served with it separately.

**BOURGEOISE** (*a la*)—In family style; indicating that the dishes are of medium richness; not costly.

**BRAINS**—The brains of all domestic animals are eaten and considered a luxury. The brains of ostriches and peacocks were among the rare and costly delicacies at the famous banquets of the ancients. Nearly all kinds obtained in our markets are by a harmless fiction classed as calves' brains, they being regarded the best, as they certainly are for a neat and compact appearance after cooking in slices; but any others do as well for the various chopped-up forms. Tubs and barrels full of brains are sent out by the pork packers; there are shops in some parts of the city where the retailing of brains is a specialty; they are put up in ten cents' portions in wooden butter dishes and sold by hundreds daily. Ox brains are equally plentiful certain seasons and are easily obtainable at all times from the dealers in fancy meats who advertise to supply hotels and restaurants. **BROILED CALF'S BRAINS**—(1)—The brains are parboiled, pressed slightly; when cold, sliced, seasoned, dipped in flour, broiled and buttered. (2)—**CALVES' BRAINS EN BROCHETTE**—Boiled brains in small pieces of even size run upon skewers, seasoned, dipped in egg and cracker dust and cooked on the gridiron. Must be previously boiled in salted water and made cold. Served on the skewers if they are of silver or plated. **BRAIN CAKES**—Lambs' or sheep's brains boiled first in milk, chopped, mixed with bread crumbs, yolk of eggs, little cream, chopped parsley, salt, pepper; made into flattened cakes, breaded and fried; served on a napkin with fried parsley. **RABBITS' BRAINS**—In England the brain

## BRA

of a rabbit is a tit-bit for a lady. **SHEEP'S BRAINS, PARSLEY SAUCE**—Laid in salted water to draw out the blood; then boiled about 20 minutes, butter sauce with parsley poured over. **SCRAMBLED BRAINS AND EGGS**—Brains boiled 10 minutes, broken up with raw eggs and scrambled in frying pan. **BRAIN PATTIES**—Scrambled brains with eggs, parsley and lemon juice mixed in, soft cooked, filled into vol-au-vent or patty cases of puff paste. **SHEEP'S BRAINS EN CAISSE**—The brains parboiled, cut in pieces, filled into little paper cases, buttered, Béchamel sauce over, and bread crumbs, and baked. **CALVES' BRAINS AU GRATIN**—Same as the last. **CALVES' BRAINS A LA PROVENÇALE**—Cooked in stock with wine, oil, parsley, garlic, onions, pepper, salt; dipped out, sauce reduced to glaze strained over them. **CALVES' BRAINS A LA RAVIGOTE**—Boiled, cut in slices and arranged in a circle with Ravigote sauce in center. **CROQUETTES OF BRAINS**—Brains chopped, made into sort of rich paste with butter, bread crumbs, eggs and seasonings, made out in ball or roll shapes when cold; breaded and fried. **MARINADE DE CERVELLES**—Brains soaked in vinegar, pepper and salt, dipped in batter, and fried. **BRAINS AU BEURRE NOIR**—Boiled, pressed, split, dipped in flour, fried in butter in a saute pan; butter turns brown and frothy, and served with them; garnished with peas, capers, or parsley, and lemon. **BRAINS FOR BREAKFAST**—The best way is scrambled with eggs and served in deep dishes by spoonfuls to each guest. (*See Cervelles.*)

**BRAISING**—The method of cooking meat in a closed pot with burning charcoal on top as well as below. It is nearly imitated in a covered baking pan in a closed oven. By braising, the meat is subjected to the action of the steam, heated to an extra degree by the fire-covered lid, and is thereby almost dissolved while still enveloped in the flavors of the herbs and seasonings in the pot itself. The French call the covered pot a *brasiere*; charcoal is called both *braise* and *charbon de bois*. The Mexicans call their charcoal furnace a *brasero*. In English it is a brazier. The South Kensington school of cookery has adopted the English words, brazier, braze, brazing and brazed, instead of *braise*, etc. Probably that is as it ought to be. **BRAISED OR BRAZED MEATS**—Are, therefore, meats cooked by brazing, with various styles in the adjuncts and sauces.

**BRANDADE DE MORUE** (Fr.)—Brandade of salt cod. The fish pulled or minced, mixed with onions, garlic, saffron, oil, pepper, etc. Is a yellow sort of hashed fish.

**BRANDY SNAPS**—A dark-brown wafer cake, containing molasses and no brandy. The dough is placed in balls, but runs out thin in baking; the cakes are shaped on a round stick to tubular shape while cooling.

**BRAWN**—English name for head cheese. Brawn is a dish of great antiquity. In olden times it was made from the flesh of large boars, which lived in a

## BRA

half-wild state, and when put to fatten were strapped and belted tight round the carcass, in order to make the flesh become dense and brawny. It came to market in rolls two feet long by ten inches in diameter, packed in wicker baskets. **BRAWN SAUCE**—Sauce for head cheese, etc.,—specialty of *chef* of Queen's College, Oxford, made by mixing 1 tablespoon mustard,  $\frac{1}{2}$  spoon moist sugar, 2 spoons oil and 4 of vinegar.

**BRAZIL NUTS**—Used for the table, but not choice; they are rather too coarse, and being so large and heavy are not profitable. But they are used in candies, and may take the place of almonds in cakes, blanc mange and ice cream.

**BRAZILIAN BREAD**—A cake made with Brazil nuts;  $\frac{1}{2}$  lb. of the pounded nuts, 12 eggs, 1 lb. sugar, 4 oz. wheat flour, 2 oz. rice flour. Baked in round tins.

**BREAM**—A fish often named in French and English menus.

**BREAD BATTER CAKES**—Pancakes or griddle cakes made with soaked bread crumbs and flour, etc., as for flour cakes.

**BREAD PUDDINGS**—(1)—In cups, made of  $\frac{1}{2}$  lb. each bread crumbs, suet, sugar and little salt; flavored with lemon rind and juice; baked; turned out; served with sauce. (2)—Bread crumbs and minced suet in a pan; sweetened, then custard, all it will absorb; baked. (3)—Slices of bread and butter in a pan, with currants, raisins, or any other fruit; thin custard to fill up; baked. (4)—Cut up crumbs of bread in dice, covered with boiling milk; butter stirred in, and eggs; flavored, sweetened, boiled in basin, tied down with a floured cloth. (5)—**BREAD AND RAISIN PUDDING**—Bread cut in dice, mixed with raisins in buttered pan, and bits of butter all through; raw custard poured in to cover bread; baked.

**BREAD PIE A LA NORMANDY**—A pie in a deep dish, made of cabbage, bread, sausage meat, an egg, salt and pepper—amount of ingredients: the white part only of one or two heads cabbage boiled and minced, a large stale roll soaked and squeezed dry,  $\frac{1}{2}$  lb. sausage meat. Bottom and top crust to pie.

**BREAD SAUCE**—One pint of broth with an onion boiled in it strained hot over 12 oz. bread crumbs; boiled for 10 minutes; 3 tablespoons cream added; salt, pepper. Served with roast fowls and partridges. **BREAD SAUCE, BROWN**—The surplus stuffing of roast turkeys stirred up in the brown gravy, passed through a fine strainer; well skimmed.

**BREAD STUFFING**—Is made of soaked bread squeezed dry, mixed with suet, lard, drippings, or sausage fat; flavored with either sage or sage and onions, or thyme and other sweet herbs; seasoned with salt and pepper, and, if wanted rich, has raw yolks added. Used for stuffing fowls, rolled mutton and veal, pork, ducks, rolled *entrecotes*, or steaks, tomatoes, egg plants, cucumbers, etc.

## RBO

**BREMEN CHEESE-CAKES**—Almond paste, 12 oz.; sugar, 4 oz.; yolks of eggs, 8; pounded together, filled in paste-lined patty pans, bit of butter on top of each, and baked.

**BRETONNE SAUCE**—Chopped onions fried in butter; flour added, and broth, salt and pepper; strained, and parsley added. A cold Bretonne sauce is made of horse-radish, mustard, sugar, salt and vinegar stirred together.

**BRIE CHEESE**—*Fromage de brie*. The richest of cheeses, flat and thin; each one is in a box by itself. It usually turns soft, and runs more or less with age, but is then esteemed the most. It is a cream cheese and like the cream cheeses made at some country dairies, but with better keeping qualities. It is about the same price as Camembert.

**BRILL**—A fish of the other side the Atlantic; it is like a turbot, flat, and is cooked in the same ways. **BRILL A LA PARISIENNE**—Specialty. Is split on the black side (back), drained and sponged dry. Laid in a baking pan with minced onions and mushrooms, salt and sufficiency of white wine, and baked. Complicated garnish of oysters, truffles, fish quenelles, tails of crawfish and mushrooms; cooked in wine, liquors; all mingled with fish gravy and thickened with egg yolks. Built up ornamentally for party. **BAKED BRILL** (or other fish)—Is soaked for 2 hours in olive oil, seasoned with lemon juice, bay leaf, salt, pepper, chives; breaded and baked; served with puree of tomatoes.

**BRIOCHE**—A yellow, rich, light kind of bread, very slightly sweetened; a sort of bun or rusk. Made by taking light dough and adding butter, eggs and little sugar and salt; letting rise again and making in shapes; letting rise again before baking. The bakers' shops of different cities show this in various shapes; one form is a ring or border of twist, glazed and sugared on top. To save eggs, the yellow color is given by colorings, and instances have occurred of poisoning by chrome yellow used in this way. Annato and saffron are harmless colorings.

**BRIGHTON ROCK CAKES**—Made to look rough by pulling off the dough with a fork on to the baking pan. Dough made of  $1\frac{1}{2}$  lbs. flour,  $\frac{1}{2}$  lb. each sugar, butter, citron and currants,  $\frac{1}{2}$  oz. ammonia dissolved in little milk. Worked together; baked in pieces, size of walnuts.

**BRITZELS OR BRETZELS**—These are the hard, brittle bowknots of salted bread eaten in nearly all beer saloons on both sides the ocean, and as popular now in France as in Germany where they originated. Made of raised dough; thrown into boiling lye when light, and afterwards baked. Ingredients only flour, water, yeast and salt; dough stiff as for crackers; well broke or kneaded. Boiling lye is  $\frac{1}{2}$  lb. potash in 10 gls. water. Britzels thrown in sink at first, then rise, and are skimmed out, salted over, and baked.

**BROAD BEANS**—A kind of bean (extensively

## BRO

grown and used in England) which grows on a stalk 4 or 5 feet high, and is cultivated in rows like Indian corn. The beans are produced in thumb-like pods; are gathered green; boiled and served with parsley-and-butter sauce. They are somewhat coarse and do not figure as an adjunct in fine dishes.

**BROCCOLI**—A green sort of cauliflower; cooked like cabbage, or pickled. The importance of the broccoli-growing industry is shown by the fact that the acreage under cultivation in the Penzance district is estimated at 1,000, each acre being supposed to contain about 10,000 broccoli—that is, for the district, a rough total of 10,000,000 broccoli.

**BROCHET** (Fr.)—Pike; a fish.

**BROCHETTE** (Fr.)—A small spit; a skewer. **LIVER A LA BROCHETTE**—Is cut in small thin slices and strung on a skewer with slices of bacon between, then broiled or fried. Oysters, kidneys, etc., in similar fashion.

**BROMA**—Cocoa or chocolate in powder.

**BROWN BETTY**—An apple pudding. (*See apples.*)

**BROWN BREAD**—May be of two or more kinds. In this country by brown bread is usually understood a mixture of cornmeal, rye, flour, graham, and, perhaps, white flour; salted, slightly sweetened with molasses and raised either with yeast or baking powder; either steamed or baked for several hours. In England, the brown bread served almost invariably with fish and oysters is made of unbolted wheat flour; here called graham bread.

**BRUNOISE SOUP**—Clear soup with vegetables and green peas.

**BRUSSELS SPROUTS**—The small cabbages which sprout from cabbage stalks after the heads have been cut off. This vegetable belongs to all dishes technically designated *a la Flamande*, or Flemish style. The sprouts are very little known in the United States, perhaps because the best way of preserving cabbage through the winter has been found to be pulling up roots and all and burying upside down in banks of earth. If the stalks are allowed to remain and continue growing with favorable weather, numerous small heads from the size of olives to that of apples will form upon them, those are Brussels sprouts.

**BUBBLE AND SQUEAK**—An English standing dish. It is cold beef and cabbage fried together; sliced beef with fat or drippings first in the pan, then the cold cooked cabbage fried in the beef fat. While this seems to have been the original homely dish, and corned beef was considered better for the purpose than fresh, various professional cooks and writers have undertaken to improve it by adding sauces or various vegetables, evidently without any warrant for it, for the name itself is enough to indicate that it is a dish of poor, but honest origin and not adapted to become high-toned.

## BUN

**BUCKWHEAT**—Kind of grain that makes a gray flour like rye or poor wheat flour, and easily adulterated. Can be made into biscuits; principally used in making griddle cakes. **BUCKWHEAT CAKES**—This popular breakfast luxury it is popularly supposed cannot be learned from printed recipes. It is among the standing jokes of the clubs that their *chefs* can never succeed in making buckwheat cakes to perfection, and colored women cooks have to be employed for that specialty. These women raise the first batch of batter with yeast, then let it turn sour by keeping some over from day to day, adding more flour and correcting the sourness with soda. Some syrup, salt and melted lard are added, and thin cakes baked on a greased griddle.

**BUFFALO**—Nearly extinct now, but a few years ago was as plentiful in the West as beef. The meat has the appearance of beef, coarser grained, but lacks the flavor; it tastes like elk.

**BUFFALO-FISH**—This name is never seen in a bill of fare, which is somewhat singular since the fish is eaten probably by tons daily down the entire length of the Ohio and Mississippi and tributary rivers; it divides the territory with the catfish. It is a carp which goes by this name; it attains to a weight of 20 pounds, but is commonly met with about half that size. The Buffalo has a good, capacious mouth and can take a bait as well as a catfish. There is, however, another fish of similar appearance, with large scales, called the sucker, which is not nearly as good a fish; its snout is elongated and mouth small; it is bony and watery when cooked. The Buffalo, on the contrary, is excellent boiled whole or fried in slices. A whole baked or barbecued Buffalo is a favorite fish at the New Orleans lunch houses where sea fish can be had just as well and as cheap. (*See carp.*)

**BULLOCKS' BLOOD BON-BONS**—At the great London exhibition of 1851, M. Brochieri exhibited and sold delicious candies, cakes, patties and bon-bons of bullocks' blood, rivalling the famous *marrons glaces* of the *confiseries* of the Boulevards, to show the food possibilities which lie in the principal ingredient of the ancient black pudding.

**BUISSON** (Fr.)—Bush. A buisson of lobsters (*de homards*) is a pyramid of red lobster on a green bush. A buisson of shrimps (*crevettes*) a smaller bush or pyramid of similar style. There are also pieces no-named which are pyramid shapes of cold butter stuck over with peeled shrimps or prawns, interspersed with cress or parsley.

**BUNS**—A bun is a sweet roll, raised with yeast like ordinary bread, though there are at least a score of different names, shapes and qualities, and quite a number of people follow the Scotch fashion of calling all sorts of soft rolls, French rolls, *petits pains*, rusks or whatever else buns, whether sweet or not, which tends to a confusion of names. However, as said above, buns are sweet rolls not so rich as cakes, and one of the best is the HOT CROSS BUN, specially

## BUR

made for Good Friday and eaten by some people for the sake of keeping up an old custom, and by more because the buns are good. A good bun can be made by any person by taking light bread dough and working into it some butter, sugar, spice or extracts, raisins, currants and candied peel, and yolks of eggs. The fruit is not always put in, and not essential, nor need there be much of either of the other ingredients; it is essential, however, to have good, lively, well-raised dough. The buns are but balls of the sweetened dough set to rise, then baked and egged and sugared over. If to be "cross buns," the cross is made by pushing down a knife nearly to the bottom of each bun while it is rising, when about half light. Other kinds of buns can be found described under the proper letters.

**BURR OAK CIDER**—Trade name for imitation cider, made of 8 oz. tartaric acid, 22 lbs. brown sugar in a barrel of water (about 40 gals.), and some baker's stock yeast, or strong hop yeast, to start a fermentation. It tastes sufficiently like cider to sell in some places in immense quantities, to the great profit of the vendors. Is ready for use in 2 days after making if moderately warm.

**BURTA**—Mashed potatoes as served in India. A large green pepper and six spring onions minced very finely, the juice of a lemon squeezed over them on a saucer. A dozen boiled potatoes mashed, and the onions and pepper mixed in, with oil or butter, and salt. Made in shape; garnished with crayfish and parsley.

**BUTTER**—It is found that, no matter how fresh butter may be or well made, if it is white it is not satisfactory for table use. The color of butter is affected by the feed of the cows, green grass and clover making it yellow; consequently winter butter is apt to be white, but may be as good otherwise. The most satisfactory for hotel use is creamery butter; it is always alike, being colored artificially, though probably less at some seasons than others. Then it is made in immense quantities at once and is uniform in quality. Certain brands of creamery are always scarce because of the demand regardless of price.

**BUTTER IMITATIONS**—A number of patents have been taken out for making artificial butter, or imitations. The first was by a French chemist, Hippolyte Mege, in 1870. He was employed on the Imperial farm at Vincennes, and invented **OLEO-MARGARINE**, which is based on the particular observation that cooked fat is granulated, therefore hard and brittle; butter is not, and therefore butter could be made out of beef fat, not cooked, but worked at the ordinary temperature of the cow's body. That is what oleomargarine is yet. The fat is made warm in steam tanks, pressed by hydraulic pressure which divides it into stearine, which remains in the sacks, and butter oil, which is pressed out, and this is churned either with milk for present use, the milk improving the flavor, or with water if long keeping

## BUT

is the object in view. There are various details, such as the dividing the butter oil into fine particles ready for the churning with milk, but in substance that is all there is in oleomargarine. If cleanly made it is as good as ordinary butter. The outcry against it has been from the makers of real butter. The only objection really sound was the selling a cheaply produced article at the high price of best butter by passing it off as butter; but that has been pretty effectually stopped, and "margarine," as the name now is, goes on its own merits, and the trade in it is constantly increasing. **BUTTERINE** was different, being a mixture of lard and butter; ostensibly, but extreme uncertainty may well be supposed to exist in the composition of it when the following patents are considered. **NUT OIL BUTTER**—A patent was taken out in 1876 for making artificial butter from oleine, margarine from fruit and vegetable nuts, lactic acid and loppered milk. "**EDIBLE FAT**," with chemicals; patent 1877. Heating suet at 140, with salt, saltpeter, borax, boracic acid, salycilic acids, withdrawing the separated fat and incorporating therewith a second and smaller charge of the above chemicals, with the addition of benzoic acid. Patent for **PRESERVING REAL BUTTER** (1880) by incorporating with it metaphosphoric acid. **OLEO-SOAP BUTTER**—Patent 1881 for adding alkali to oleomargarine, "agitating the mixture until partial saponification ensues, then adding butyric acid." **COTTON SEED BUTTER**—Patent 1882 for combination of beef-suet oil, cotton-seed oil, beef-stearine and slippery elm bark. **LARD AND COTTON-OIL BUTTER**—Patent 1882 for combination of lard oil and cotton-seed oil, "deodorized and purified by slippery elm bark and beef stearine." **COCOANUT AND COTTON-OIL BUTTER**—Patent 1882 for combination of vegetable stearine from nut or cotton oil pressed cold, with oleomargarine, and churning. **OLEO, LARD AND AQUA FORTIS BUTTER**—Patent 1882 for combination of oleomargarine and leaf lard, subjected to washing action in water, borax and nitric acid; then re-washed and churned. **THE REAL BUTTERINE**—Patent 1882 for artificial butter made by minutely dividing leaf lard, melting, covering, salting down for 3 days, mixing it with lukewarm buttermilk, clarified tallow and little pepsin; adding half its weight of real butter, and working in cold water. **COTTON-OIL AND FLOUR-PASTE BUTTER**—Called "Oleard." Patent 1882; "vegetable oil in combination with cooked farinaceous flour," the oil treated with a solution of caustic soda. **MAKING TWO POUNDS OUT OF ONE**—Patent 1886 for putting into a churn 8 lbs. butter, 1 gallon sweet milk, 1 oz. liquid rennet, 25 grains (troy) of nitrate of potash, 1 oz. sugar, ½ teaspoon of butter-coloring; churning all, and working. *Note*—Milk and butter warm can be mingled by stirring together gradually; the additions specified are to make the combination hold when cold.—Notwithstanding the possibilities outlined in these patents, there is very little more than a local practice of the methods. Oleomargarine is the same as Mége invented in 1870, viz.: beef fat

## BUT

melted or cooked at 150 degrees; the oil pressed out and churned with milk. Butterine is a mixture of the above with leaf lard salted, colored and churned, the milk it is churned with giving the butter flavor. State commissioners have reported favorably upon the products of the large factories where fresh fat from the slaughter-houses is of necessity the material used. **TO DISTINGUISH BUTTERINE**—The following simple method has been suggested for approximately judging of the purity of a specimen of butter: Melt the butter, and then cool it as rapidly as possible by means of some ice-cylinder put into it. Lard, which is a copious constituent of butterine, will sink to the bottom, and any genuine butter will rise, while there will be a distinctly visible zone or line of contact between the two. **BUTTER TO KEEP FRESH**—Washing in cold water till free from buttermilk, salt and sugar added in equal quantities, and packed in jars and kept cold it will keep fresh for a year. **A TEST FOR BUTTER**—There is a qualitative test for butter so simple that any housewife can put it into successful practice. A clean piece of white paper is smeared with the suspected butter. The paper is then rolled up and set on fire. If the butter is pure the smell of the burning paper is rather pleasant; but the odor is distinctly tallow if the "butter" is made up wholly or in part of animal fats.

**BUTTER-BALL DUCK**—A wild duck a little larger than a teal; good quality; generally very fat; suitable for broiling, and often takes the place of teal. In season November, December, January and February.

**BUTTER BEANS**—Lima beans.

**BUTTER-FISH**—Small fish, fried like small trout or whitebait.

**BUTTER PIE**—A bakery specialty; a flour and butter custard made without eggs; baked in a crust.

**BUTTER ROLLS**—A variety of French bread; rolls with butter worked in the dough; made flat to split, and butter spread inside. Served hot.

**BUTTER SCOTCH**—Taffy, a brown kind of candy; made by boiling moist sugar and butter together to the crack, and cooling in sheets in shallow pans. Also a sweet cake sold at some shops.

**BUTTERED APPLES**—Quartered apples baked with butter and sugar; served on fried bread.

**BUTTERED EGGS**—Eggs soft scrambled in a saucepan, set in a pan of boiling water, with plenty of butter.

**BUTTER NUT**—Kind of walnut, longer in shape and harder shell than the black walnut. Also the *souari* nut of Demerara.

**BUTTS OF BEEF**—One of the new cuts of the packing houses; the buttock cut in two or three; boneless, good for second-rate steaks, and lower in price than choice loins.

## CAB

## C.

**CABARET**—(Fr.)—A wine shop.

**CABBAGE**—Most ancient of vegetables used for food and still popular; classed among the most nutritious, containing nitrogen, the same as meat, which causes its strong odor. **ODOR OF BOILING CABBAGE**—Three remedies which prevent the offensive smell are: (1)—borax in the water, (2)—a piece of bread tied up in muslin and boiled with it, (3)—a large lump of charcoal tied up and boiled with it. **BUBBLE AND SQUEAK**—Is a dish of fried cabbage and beef. **CABBAGE AU GRATIN**—Boiled cabbage in layers with grated cheese and butter, pepper and salt, with breadcrumbs or cracker dust on top; baked. **CABBAGE A LA MILANAISE**—Cooked cabbage in a dish, thin broiled ham on top, butter sauce poured over, grated cheese for top crust, baked. **CABBAGE SPROUTS WITH EGGS**—The young sprouts from cabbage stalks boiled; an omelet laid flat on dipped toast and cabbage sprouts on top of omelet. **CABBAGE STEWED WITH BUTTER**—Young cabbage quartered and blanched, cut small and fried in butter, broth added, stewed down, little white sauce or flour to finish. **CABBAGE A LA ST. DENIS**—Stuffed with sausage meat, wrapped with slices of fat pork, stewed with flavoring of sherry in broth, sauce poured over cabbage when served. **PAUPIETTES OF CABBAGE A LA MILANAISE**—Cabbage leaves blanched, sausage meat, parboiled rice shallots and parsley mixed and rolled up three leaves thick; simmered in saucepan close packed for an hour. **CABBAGE A LA NAVARRAISE**—Stewed in butter and broth flavored with garlic, cloves, etc. **CHOUX FARCIS**—Stuffed with sausage meat, same as *St. Denis*. **CHOUX EN SURPRISE**—Cabbage stuffed with chestnuts. **CREAMED CABBAGE**—Boiled, drained, stirred up in a saucepan with butter and cream. **CABBAGE A LA LILLOISE**—Fried cabbage, put in raw; chopped, with onion and butter. **BOILED CABBAGE AND BACON**—Quarters of summer cabbage boiled green and drained, a slice of bacon on each. **CABBAGE A L'ALLEMANDE**—Boiled, drained, chopped, boiled bacon cut in dice mixed with it and little white sauce. **BAKED CABBAGE**—Cooked cabbage minced, in layers with minced cold meat in a dish lined with crumbs, and bacon on top; to be turned out whole. **RED CABBAGE WITH SAUSAGES**—Stewed with broth and vinegar; boiled sausages around in the dish. **RED CABBAGE A LA FLAMANDE**—Fried salt pork, shredded cabbage and sliced apples together, broth and brandy added, and finished in covered pan in the oven. **PICKLED CABBAGE**—White is generally colored yellow with turmeric; red cabbage is usually preferred for pickling. **CABBAGE SALAD OR COLD SLAW**—(1) Plain white solid cabbage shaved as fine as hay, seasoned with salt, vinegar, etc.; generally served with oysters. (2)—Chopped cabbage and apples, salt, vinegar, pepper and capers. **HOT SLAW**—Shaved cabbage in hot creamy sauce of vinegar, water, butter, eggs,

## CAB

salt, sugar; scalded, not boiled. SAUERKRAUT—Shaved cabbage in layers in a barrel with salt between, pressed down and kept till it becomes sour. CABBAGE SOUPS—Consommé Paysanne contains shred cabbage; and vegetable soup with a salt pork or corned beef seasoning and large proportion of cabbage. CABBAGE TO KEEP—Burying in a bank of earth, heads downwards and stalks and roots left on, covered with a foot of earth, is found to be the best way. CABBAGE AS A PANACEA—Hippocrates had a peculiar affection for cabbage. Should one of his patients be seized with a violent colic, he at once prescribed a dish of boiled cabbage with salt. Erasistratus looked upon it as a sovereign remedy against paralysis. Pythagoras and several other learned philosophers wrote books in which they celebrated the marvelous virtues of the cabbage.

CABILLAUD (Fr.)—Codfish.

CABBAGE PALM or PALM CABBAGE—Edible young leaves and heart of a palm tree which grows in Florida and southward.

CABINET PUDDING—A mould or pan nearly filled with slices of cake, with sultana raisins and cut citron between the layers; a custard mixture of eggs and milk poured over; baked. STEAMED CABINET PUDDING—A mould ornamentally lined with raisins and citron and soft butter; filled with sponge cake, macaroons and custard; steamed and turned out whole. COLD CABINET PUDDING—A charlotte russe made with lady fingers and small macaroons lining a mould, filled up with yellow custard containing gelatine to set it.

CACTUS LEAVES CANDIED—The thick, fleshy leaves of a cactus, crystallized in sugar, forms one of the articles of export from Mexico.

CACAO—The cacao (pronounced ka-ka'-o) bean is the fruit of the cacao tree, a native of Mexico, but now cultivated in all tropical countries. It is a small tree, from 16 to 18 feet high, and the seeds are the parts used for food. They are contained in a large-pointed oval pod, from 6 in. to 10 in. long. This pod contains much sweet and whitish pulp, and from 50 to 100 seeds, or beans as they are usually called. When dried and roasted, and separated from the husk, the beans form cocoa; chocolate is prepared by grinding the roasted beans with sugar and flavoring essences and then pressing the paste thus made into cakes.

CAERPHILLY CHEESE—A special kind produced in Wales.

CAFE (Fr.)—Coffee; also coffee house. CAFE AU LAIT—Boiled milk and coffee in equal parts, little cream. CAFE NOIR—Strongest black coffee, and sugar to taste. CAFE GLORIA—Good bright breakfast coffee and cognac, equal quantities, with sugar; this can be set on fire with brandy on top. CAFE GRANITO—Frozen coffee well sweetened; no additions but sugar, served semi-fluid in small cups. LIQUEUR DE CAFE—Strong, clear coffee, strong sugar syrup, and spirit, equal parts. RATAFIA DE CAFE—A

## CAL

pound of ground coffee steeped ten days in a quart of spirit, strained, added to a quart each of syrup and water, flavored with spices and almonds. CAFE A LA CREME FRAPPE—*Cafe au lait* set in ice till half frozen; better when made with cream in the coffee, instead of milk. SOUFFLE AU CAFE—Frangipane with white of eggs, flavored with coffee, baked in soufflé cases. SOUFFLE AU CAFE VIERGE.—The same with green coffee flavor. CREME DE CAFE—Coffee ice cream.

CAILLES (Fr.)—Quails.

CAISSES (Fr.)—Little cases of paper or wafer paste, size of patty pans or tumblers and of various shapes, for serving soufflés and small meats, also for ices, as biscuits glacés.

CAKES—Various kinds may be found mentioned under their respective letters.

CALLIES—Dealers' name for large deep-sea oysters, set apart for cooking purposes; smaller ones being better to serve raw.

CALIPASH—The meat attached to the back or upper shell of the turtle.

CALIPEE—The meat attached to the belly or lower shell of the turtle. In consequence of the prominence given to turtle by its adoption at the stupendous civic banquets in London as the leading luxury for the past 150 years, a knowledge of the parts and ways of cooking is essential to a gastro-nomic education. (*See turtle.*)

CALF'S BRAINS—See brains.

CALF'S EARS—Are cooked separate from the head in various ways. OREILLES DE VEAU FARCIS—Calf's ears first boiled tender, stuffed with any savory stuffing of minced bacon, onions and bread, or sausage meat and bread, or chicken stuffing, breaded and fried. OREILLES DE VEAU EN MARI-NADE—Boiled tender, steeped in seasoned vinegar, drained, dipped in batter and fried. OREILLES DE VEAU AUX CHAMPIGNONS—Calf's ears boiled tender, served in a brown sauce with mushrooms, and yolks of eggs for garnish. CALF'S EARS STUFFED, TOMATO SAUCE—Simmered tender in stock with vinegar, stuffed as above, breaded and fried, served with tomato sauce, and parsley and lemons for garnish. CALF'S EARS A LA LYONNAISE—Cooked ears cut in shreds; fried onions in gravy and the calf's ears mixed in. CALF'S EARS A LA BECHAMEL—Ears cut off deeply, core removed with round cutter, boiled an hour in milk and water, stuffed with veal forcemeat, tied, simmered in seasoned broth; taken up, sauce strained and thickened, mushrooms and parsley added. OREILLES DE VEAU A LA NAPOLITAINNE—Stuffed with bread and cheese stuffing, with butter and yolks, breaded and fried.

CALF'S HEAD—It is useless if skinned as many country butchers send it in after, perhaps, repeated requests. The head can be cleaned by scalding, same as a pig, and scraping. A little lye, ashes or soda in the water assists the operation. The head



## CAL

after being scraped is singed, then beginning at the throat the skin and meat is all taken off the bones by close cutting under with the point of a knife, and next the tongue taken out, the head split and brains taken out. **CALF'S HEAD BOILED**—Cooked in seasoned stock about an hour or more, taken up, pressed between dishes; when cold cut to shapes and served in various ways. **CALF'S HEAD A LA POULETTE**—Cream-colored sauce with mushrooms, calf's head sliced in it, garnished. **CALF'S HEAD A LA MENEHOULD**—Slices dipped in thick sauce (*Duxelles*), then in cracker dust, then in egg and dust again, and baked or fried. **TETE DE VEAU EN MOULE**—Calf's head minced, layers in a mould with minced ham between, thick gravy to moisten, baked, turned out whole; the mould is lined with bread crumbs and butter. **TETE DE VEAU A LA FINANCIERE**—Square pieces or slices with *financiere* garnish of mushrooms, wine, etc. **CALF'S HEAD A L'ITALIENNE**—Boiled, sliced, with Italian sauce poured over. **CALF'S HEAD A LA DESTILIERE**—Pieces in center of dish, brain sliced on top, tongue cut in dice, sliced gherkins, button mushrooms in espagnole and wine sauce poured over. **CALF'S HEAD WITH EGGS**—Slices in mushroom sauce garnished with an egg, round-fried like a fritter, in plenty of oil or lard. **CALF'S HEAD A LA TORTUE**—The cold pressed head cut in squares, made hot in rich gravy with little tomato sauce, wine, mushrooms, forcemeat balls, hard egg yolks, olives, etc. **CALF'S HEAD SOUP**—A light-colored soup having chopped green vegetables, seasoned with herbs, half-fried onions, anchovy essence, the calf's head cut in dice in it. **MOCK TURTLE SOUP, CLEAR**—Brown consommé, with cubes of pressed calf's head, egg balls and parsley. **MOCK TURTLE LIEE, OR THICK**—Brown, made with calf's head and finished same as turtle soup. **TURBAN DE TETE DE VEAU**—Pieces of cooked and pressed calf's head, made hot in any sauce or ragout, dished up in crown shape, perhaps on a foundation of bread or rice (see illustration on page 117), and the sauce poured over; the name is according to the sauce. **CALF'S HEAD CHEESE**—Similar to pig's head cheese or brawn.

**CALF'S FEET**—Are freed from bones after cooking, cut up and fricasseed, white or brown; or served with any of the well-known sauces, such as tomato, hollandaise, parsley, piquante, caper, etc. **CALF'S FOOT SOUP**—A cream soup of boiled calves' feet, celery and other vegetables, cream, white wine and raw yolks for final thickening. **CALF'S FOOT JELLY**—Nearly all wine and other table jellies and creams for sweet dinner and ball supper dishes were formerly made by boiling down calves' feet to a jelly, then sweetening, flavoring, clarifying and filtering it. One foot makes one quart of jelly. A shorter method is now to use the prepared gelatine. Calves' feet enrich soup stocks, and are good for making aspic jelly.

**CALF'S LIVER**—See liver.

**CALF'S SWEETBREADS**—See sweetbreads.

## CAN

**CALF'S TAIL SOUP**—White soup; the tails in short pieces stewed, vegetables, mushrooms, slice of bacon, inch of lemon rind in the strained stock, corn starch, milk, nutmeg, glass white wine, pieces of calves' tails added last.

**CAMEMBERT**—One of the favorite cheeses for *recherché* dinners; can be bought of the importing grocers; is a flat-shaped, "salt-soft" cheese of only a few pounds' weight; costs about double the price of ordinary cheese. Where they are made Camemberts are dried for a month in a carefully constructed room with a peculiar system of ventilation. They are then ripened for about the same length of time in a curing cellar, called a *cave de perfection*, where they are watched and treated with the greatest care. The formation of the white mould and the development of the red spots on their surface are observed with great anxiety, and every little cheese is turned or left according to circumstances.

**CANAPES**—Literally couches, sofas, but in culinary language pieces of toast or bread with something spread upon them. **CANAPES AUX ANCHOIS**—Chopped anchovies and eggs on fried bread. **CANAPES AU FROMAGE**—Cheese melted in the oven on fried bread. **CANAPES A LA PRINCE DE GALLES**—Mixture of anchovies, ham, truffles, gherkins, oil and vinegar in small hollowed rolls, decorated with aspic mayonnaise. **CANAPES A LA WINDSOR**—Chicken, ham, cheese, anchovies, butter, cayenne, salt, pounded to a paste together, passed through a sieve, spread on fried bread, crumbs on top; baked a few minutes. **CANAPES OF SARDINES**—Strips of fried bread spread with sardine butter made by pounding sardines with hard-boiled yolks and butter, mixed with parsley, mustard, etc.; a boneless, half sardine on each one; served hot. **CANAPES OF SHRIMPS**—Fried rounds of bread spread with thick shrimp sauce and picked shrimps enough to cover the sauce. **CANAPES DE VOLAILLE**—Chicken canapés or sandwiches with buttered bread, shred lettuce, mayonnaise sauce on the lettuce, breast of chicken and fillets of anchovy next, and bread on top.

**CANARY YELLOW**—Chrome yellow; poisonous coloring. Its use by bakers is forbidden by law.

**CANARDS (Fr.)**—Ducks.

**CANDIED YAMS**—The large, sweet potatoes called yams are boiled, sliced, laid in a pan with sugar, butter, very little water and nutmeg, and slowly baked. Served hot for dinner with the vegetables.

**CANDIED FRUITS**—(See *crystalized fruits*.)

**CANETONS (Fr.)**—Ducks. Usually applied to tame ducks. **CANARD SAUVAGE**—Wild duck.

**CANE SYRUP AND SUGAR**—Meaning the product of the sugar cane; not sorghum, nor beet sugar, nor glucose, nor maple.

**CANDLE-FISH**—A long, eel-like fish of the extreme north, eatable, oily; when dried is burned like a candle.

## CAN

CANNEBERGES (Fr.)—Cranberries.

CANNELONS (Fr.)—Canes; fried rolls of puff paste little larger than a finger, having a pith of either minced meat or of jam inside. CANNELONS BAKED—Are brushed over with egg and water before baking. *Note*—Fried cannellons are now usually called *rissoles*.

CANNED MEATS—Are robbed of their juices when put up in the factories; the natural gravies are taken to make meat extracts and canned soups, and replaced with water in the canned meats.

CANNED GOODS—There is the utmost need for the hotel buyer to post himself early on the subject of canned goods. The margins are sometimes as great in proportion to prices as in the case of wines. Some merchants will make astonishingly low prices for ordinary provisions and groceries if the buyer will let them supply the canned goods at list prices. This is because of the great variations of quality of these goods and also the fluctuations in prices dependent upon the fruit or vegetable harvest being good, or otherwise. Goods which retail ordinarily at 20 cents a can may often be bought by the case at 5 or 6 cents, and generally at 10 or 12. Among the fine goods there are grades according to strength of syrup and selection of fruit. There are peas which are only dried peas cooked and canned, and others, the finest green June peas, better than if fresh bought in market; but the inexperienced may have to pay as much for one as the other. And the hotel buyer should get everything in gallon cans and kegs, as near as possible, not pay for loads of small bottles, jars and labels.

CANNING—There are two principal methods; one is to fill the cans with raw goods, like the French peas, with sufficient water and perhaps some coloring agent to green them; solder them tight, and throw them into a boiling kettle where they remain for 3 or 4 hours. The other way is commonly known, consisting in cooking the cans of vegetables and fruit in steam closets, there being an aperture in the top of each can which is closed up with solder after the contents are cooked and while still hot.

CANTELOUPES—The nutmeg melon. Plentiful in summer and fall and used by the wagon load in our hotels; kept on ice, washed, dried, cut in halves, broken ice strewed over; served a half to each person, unless very large, when a quarter may be enough. Eaten with salt and pepper.

CANTERBURY PUDDINGS—Individual, in cups. Very rich pound cake mixture of 2 oz. each butter, sugar and flour, 2 eggs whipped light, lemon rind to flavor; baked in buttered cups; wine or brandy sauce.

CANTON GINGER—Preserved ginger root, a sort of candy; especially valuable in fruit ice-creams, ginger-ice, tutti-frutti, choice small cakes, steamed puddings and wherever citron is used. It has an agreeable pungency. It comes principally from Chy-

## CAN

loong's factory in Canton; costs here from 30 to 40c. per pound. "Old Chyloong shows with pride how the root is brought to him and put through all the processes. It is scraped, soaked in water for five days, picked with forks, boiled in water, soaked for two days in rice-flour water, boiled again, soaked in lime water, boiled some more and finally boiled with its equal weight of brown sugar and put up in the round ginger jars sacred to high art, young ladies and the Dusantes mantelpiece. The dried ginger goes through all these processes, and is then dried in the sun. The mixed Cantonese preserves, containing bits of citron, sugar-cane, melon rinds, cumquats and persimmons, are made at the same place, and Chyloong is a purveyor as widely known to the civilized world as Crosse & Blackwell, and no doubt a millionaire."

CANTON BUNS—Sweet cakes made of  $\frac{1}{2}$  lb. each butter and sugar, 2 eggs,  $\frac{1}{2}$  oz. ammonia,  $\frac{1}{2}$  cup milk,  $1\frac{1}{4}$  lbs. flour; in balls dipped in egg on top and little rough lumps sugar and an almond; baked.

CANVAS-BACK DUCK—"Mr. Dion Boucicault recently sent Mr. Irving a present of American dainties, which were served at some supper parties which have been given in the beefsteak room at the Lyceum after the performance. Mr. Irving's opinion having been required, he cabled to the donor: 'Our verdict is: perfect. Perfect terrapin, the finest soup known. Canvas-back ducks ethereal.' A celebrated novelist who visited the States a few years ago, gave up all engagements in order to dine with a *gourmet* twelve days running on canvas-back ducks and champagne. It is strange that the canvas-back duck can never be caught alive. A prominent caterer of New York has been trying for three years to execute a commission of Lord Tarbets', second son of the Duke of Sutherland, who sent over for two pairs of live canvas-backs. There is a standing offer of \$50 a pair for them, but as yet no one has got it. It is impossible to net them as you do other ducks; the only chance is to wound one badly enough to capture him, but not severely enough to kill him. Though many persons annually enjoy the sport of shooting canvas-back ducks, the joy of Maryland sportsmen and the pride of Baltimore epicures, few have probably thought of the summer homes of the ducks, where the vacancies in their number, caused by the industry of winter fowling, are filled by young birds. The ducks are found along the Atlantic coast as far north as Canada, but they migrate in the greatest numbers in the fall to the Chesapeake Bay and its tributaries, where they find their favorite food, the *valunena*, or wild celery, a freshwater plant, whose roots they feed upon, and which gives them the juiciness and peculiar flavor which distinguishes them from other ducks and atones for their comparative lack of bright plumage. They follow winter down the Atlantic coast, and remain in the Chesapeake waters during the winter months. When the spring opening occurs, they

## CAN

wing their way across the country in a north-westward direction, and spend the summer months breeding and raising their young in the neighborhood of the cool waters of the upper Rocky Mountain system, and in all the far countries north of the fiftieth degree, north latitude. There alone can their eggs be obtained. A well-known restaurateur of this city conceived the idea of raising canvas-back ducks in Baltimore. He procured two crippled birds—a male and female—but his experiments were unsuccessful, as the birds pined for the cool air of the British American forests. The canvas-back duck is the royalty of ducks. No other approaches him within the circumference of the earth. His delicacy of flavor and his rare and melting juiciness are attributable to his delicate feeding, which is wholly on wild celery. This duck must be roasted at a rapid fire; brownly—almost *blackly*—crisp, and served without one goût of sauce or flavor, and with no condiment save a modicum of salt and some sticks of white crisp celery. It is a kind of barbarism to disguise in wine or jelly the melting natural richness of this bird; and if properly cooked, his own crimson gravy will be abundant and delicious. Knowing that having got your duck the next thing is to eat him, the reporter called upon a well-known caterer for information as to the proper way of cooking the bird. Here, to his surprise, he met with a statement which contradicts all the encyclopædias since the canvas-back duck was given a place therein. He was informed that the canvas-back duck does not eat wild celery. It has been popularly supposed that the superiority of the Havre de Grace and Potomac River birds was due to the fact that they ate nothing but wild celery, but this famous caterer says that they feed upon a plant called *valesneria*, the roots of which are covered with thousands of little insects extremely acceptable to the palate of the canvas-back. However this may be, there is no doubt that when you get a canvas-back you should cook him as follows: Loøse as little of the juice or blood as possible. The best way is to split him down the back after plucking and singeing him very carefully. Then lay him on a gridiron with the spli side toward the fire; keep him flat on the gridiron either by pressing him down with the other half of the gridiron or by putting on a weight sufficient heavy for the purpose, but not heavy enough to bruise the meat. Let him remain over the fire for twelve or fifteen minutes; then take him off and expose the breast to the heat for a moment, just long enough to brown the skin nicely, and then serve him immediately before he has a chance to get cool. A salad of celery with a mayonnaise dressing is the proper thing to eat with him. This with a bottle of very dry champagne frappée makes a course for a king. CANVAS-BACK IN SEASON—Its season lasts 6 months, November to April, inclusive; the first half of the season being its prime. ROAST CANVAS-BACK—Singed, drawn, wiped inside with a cloth and dusted with salt. Trussed with the head closing

## CAP

the upper opening, the rump the lower one; roasted in hot oven about 25 minutes. Dusted with salt, spoonful of water inside to increase the gravy, served on a hot dish; celery and currant jelly served separate.

CAPERCAILZIE—A variety of grouse in Norway and Scotland, similar to the spruce grouse of the Rocky Mountains, which feed on pine leaves in winter. Require to be hung to make them tender, and the breasts larded. Cooked as grouse and prairie hens. COLD CAPERCAILZIE PIE—Meat taken off the bones and partly fried in butter, then briefly steeped in marinade of vinegar, onion, nutmeg, pepper. Sausage meat mixed with bread crumbs and chopped yolks made. Pie dish bottom covered with sliced bacon, meat and sausage forcemeat in alternate layers, wine, lemon slices, buttered paper; no top crust; baked in slow oven several hours; eaten cold.

CAPERS—Pickled green berries of a shrub, an old-time favorite relish to eat with mutton. Can be bought in cheaper ways than by the small bottle; there are gallon jars and kegs of different sizes.

CAPER SAUCE— Butter sauce with capers and some of the caper vinegar mixed in. PUREE OF CAPERS—Another caper sauce made by pounding capers through a strainer or seive and mixing the pulp with butter sauce hot, or with softened butter cold. Used for boiled and broiled fish, mutton, lamb, tongue, tripe, etc.

CAPER SUBSTITUTES—The flower of the marsh marigold are used, and the pods of the nasturtium flower pickled; these are thought to be as good as capers.

CAPOLITADE DE VOLAILLE—Pieces of fowl in Italian sauce, with capers.

CAPON—A sterilized fowl of either sex, fed and fattened for market. Capons attain to twice the weight of ordinary fowls. ROAST CAPON—Same as turkeys and fowls, with stuffing and butter basting. Giblet sauce or brown sauce from the baking pan. BOILED CAPON WITH SALT PORK—Same as chicken or turkey. "A capon is not so profitable as a fowl, as it wastes very much in cooking. The bird being fed on barley-meal and milk, the flesh is necessarily finer. CAPON PIE—"Should you be in Dorsetshire or Hampshire, and see before you a capon pie, the capon stuffed with truffles and innumerable dainties, eat. Eat, be it morning, be it noon, or be it night. Eat, and be thankful for your introduction to one of the greatest luxuries the mind of man has ever conceived."

CAPSICUMS—The small red peppers used in bottled pickles. ESSENCE OF CAPSICUMS—Cayenne pepper in spirit, used in seasoning instead of pepper. CAPSICUM BUTTER—For sandwiches; butter and cayenne.

CAPTAIN'S BISCUITS—Home-made hard-tack.

## CAR

**CARAFES FRAPPEES**—"Those who know the French capital will readily recall the delightfully refreshing and almost picturesque appearance along the Boulevards of innumerable balls of what appears to be frozen snow in elegantly-shaped and scrupulously clean water-bottles, or *carafes*. These *carafes frapees*, as they are called, are supplied to restaurants all over Paris by a company, at a charge which is a little more than nominal. They are brought around in carts with the regularity of the post, and are renewed sufficiently often to enable restaurants of the largest clientèle to supply their customers with water brought down to the temperature of ice." **BALL OF ICE IN A BOTTLE**—"It was in the Café de la Paix that I saw him thus, and his strange appearance attracted my attention. On the marble slab before him stood an empty coffee glass and a *carafe frapee*. It had puzzled him; it puzzled me once. I have heard many and various explanations given which were far from being satisfactory. A lady of my acquaintance opined, and opines still, for all I know, that the bottles were made round the ice. another, a scoffer, that the ice wasn't ice at all, but ground glass; others that it is an optical illusion, and so on. But after all it is a very simple matter, and as easy of comprehension as is the manufacture of ice-cream, only that in this case the bottle must be filled three-quarters only, and be of tough glass, to minimize the chances of a very animated 'bust'."

**CARAMEL**—Burnt sugar. Said to have been named from a Viscount Caramel. It is the stage in boiling sugar when the boiling ends and it begins to turn brown. At that stage it has a pleasant taste like some brown candies. **CARAMELS**—Name given to various kinds of candies, generally of a dark sort. **CARAMEL COLORING**—Sugar burnt in a frying pan till it smokes and turns black, water then added, boiled, strained; used for giving the brandy-color to soups, jellies and spirits. **CARAMEL PUDDING**—Sugar melted brown in a mould and run all over the interior while cooling; filled up with custard of cream and yolks; steamed. **CARAMEL ICE CREAM**—Brown almond nougat made by melting sugar to caramel with almonds mixed; when cold, pounded fine and mixed in ice cream instead of sugar.

**CARAWAY SEED**—Seed of a garden herb; grows like seed of carrots and parsnips; cheap in the drug stores; used in various cakes and sweet crackers, used by the Germans in rye bread, used steeped in spirits to make *kummel*, and in various liqueurs.

**CARBONADE DE MOUTON (Fr.)**—Loin of mutton.

**CARBONIC ACID GAS**—The "fizz" of soda water, etc.

**CARDINAL PUNCH**—One pineapple sliced in a bowl with powdered sugar, and left to stand a few hours; the peel of the pineapple boiled in little water which is strained to the fruit for higher flavor; 2 or 3 bottles good white wine added and about 1 lb. sugar. Set on ice. When served, a bottle of seltzer or

## CAR

champagne added. **STRAWBERRY CARDINAL**—One qt. fine red-ripe strawberries in a bowl with 1 lb. sugar and 1 bottle red wine. Set on ice. When served, 2 bottles Rhine wine or Moselle, 1 bottle champagne or seltzer. Both of these may be frozen and served semi-fluid in punch glasses, but need more sugar for that.

**CARDINAL SAUCE**—It signifies red sauce, cardinal red having that name in allusion to the red capes worn by the cardinals of the Romish church. And the red sauce is made by mixing lobster coral—the eggs or roe—in butter sauce, with some other approved flavorings for a relish with fish.

**CAREME**—A name often met with in the literature of epicurism. It is necessary to a polite education to know something about a name so prominent. Carême was an original genius who happened to be a cook, had the good fortune to get into the employ of kings and emperors, and seeing his advantages and having the ability, he wrote books and laid the foundation of a new school of cookery. It was Carême who invented or re-invented the great list of sauces now in use—the hot sauces and garnishes and ragouts—of which the names even have never been learned outside of France. There was another able man at the time doing practical work, Beauvilliers, the founder of the French restaurant, of whom it has been said he exhausted the classical school of cookery; he used up all the resources of the old world, but Carême invented a new one. Carême made a new departure. In Carême's time and afterwards, the old names and fashions of cookery disappeared and the uniform, almost universal language of the art, spread from Paris to all the civilized capitals; it was the end of the old feudal era of boar-hunting barons and coarse feasting and the beginning of a period of gastronomical refinement and the cultivation of the manners of the table. Carême died less than fifty years ago. He was doing his best work in the first quarter of the present century. We have some of his recollections of great men, which was written in 1832. He wrote several books on cookery and kindred subjects; one of them was his *Maitre d'Hotel* or steward-cook. He himself was *maitre d'hotel* at one time to Prince Tallyrand in that famous man's old age. He was in the employ of the emperor Alexander of Russia, at \$6,000 a year, and spent for the emperor \$5,000 a week on the kitchen and table. Carême was not an economical cook or steward, neither are they who follow him faithfully. And yet he wrote in praise of economy and claimed to practice it. Before that time he had been cook to King George of England, but left London in disgust, complaining of the dullness of both the people and the climate. It is said the immediate cause of his leaving England was an insult he imagined he had sustained through the king having added salt to one of his soups and eaten asparagus with one of his new entremets. But in Russia he was not quite satisfied, and looked back upon the massive furnishings of the English table

## CAR

with something like regret. "When he cooked for the Emperor Alexander he never could reconcile himself to the Russian fashion of 'a table not six feet broad' and mostly wasted on flower pots, which enforced the carving up beforehand of all his glorious *grosses pieces*. No, his pet crotchets were better humored by the oval table of polished steel at the Prince Regent's pavilion, which was heated by steam, like a hot plate, and was large enough to hold forty entrees at one time, in addition to its monster decorations. Before the Revolution iron tables of this kind were, Carême says, to be seen in the Chateaux of France and the private 'hotels' of Paris. And it is no wonder that iron was employed, for, gross as the custom was in Carême's time, it was much worse about 1750. He copies from Vincent la Chapelle one *menu* for 100 guests, which comprised 24 soups, removed by as many large dishes of fish; 48 joints; 66 dishes of oysters, replaced by 66 entrees; 34 cold meats and 48 roasts; besides, 66 salads, followed by 66 other entremets, and 30 sauces. Thus no fewer than 472 different dishes of all sorts—round, oval, square, octagonal and fanciform—had to be put on the table, and with all this each pair of elbows had but eighteen inches play." Carême was not the finisher of a reform movement, he was the beginner of one. His works were grandiloquent and verbose and not adapted to be translated, and do not appear to be in print in English, if they have ever been. The essence of Carême's work is in Francatelli, and French manners and fashions have now left both behind. Beauvilliers and Carême were the chief of two opposite schools of cookery—the classical and the romantic. According to Mr. Hayward, "Beauvilliers was more remarkable for judgment, Carême for invention; Beauvilliers exhausted the old world of art, and Carême discovered a new one; the former was great in an entrée, and the latter sublime in an entremet; and while Beauvilliers might be backed against the world for a rôti, Carême alone could be trusted to invent a sauce."

CARDON (Fr.)—Cardoon.

CARDOON — Imported vegetable; uncommon; Spanish thistle heads. The stalks of the inner leaves are the parts eaten. CARDONS A L'ESPAGNOLE—Freed from the soft stalks, and prickly edges rubbed off with a towel; cut in 4-inch lengths, parboiled, peeled, boiled in white broth with lemon juice and aromatics, served with espagnole and butter. SPANISH CARDOONS WITH MARROW — Served with pieces of marrow toast. FRIED CARDOONS—Tied in bundles like asparagus and boiled, rolled in flour and fried in butter; served with butter sauce. CARDONS AU JUS — Parboiled, scraped, stewed, served with brown sauce and beef marrow. CARDONS AU GRATIN—Covered with bread crumbs, moistened with butter and browned in the oven. PUREE DE CARDONS AUX CROUTONS—Cardoons stewed in stock, passed through a seive; the pulp mixed with cream, served on fried rounds of bread.

## CAR

CARDONS AU PARMESAN — Cardoons blanched, scraped, boiled, breaded, fried light color, dusted with grated Parmesan, garnished with fried parsley.

CARRELETS (Fr.)—Flounders; flat-fish.

CARRE DE MOUTON (Fr.)—Neck or rack of mutton.

CARROTS—Necessary for soups and in stock for sauces; not in much demand as a vegetable in this country. In England nearly always served with boiled salt beef. CARROTS IN CREAM—Young carrots scraped, parboiled, cut in slices, simmered with very little water till tender; milk, butter, salt, pepper and corn-starch thickening. CARROTS A LA FLAMANDE—Prepared like the last, finished with egg yolks, thickening them like custard, pinch sugar and chopped parsley. STEWED CARROTS—Same as in Cream. GLAZED CARROTS—Young carrots, all one size, parboiled, then boiled in seasoned stock with butter and little sugar; dried down to a glaze. SAVORY CARROTS—Fried in slices with butter, onion, pepper, salt, little flour; when brown, broth added; simmered tender. CARROTS AND GREEN PEAS—Carrots cut in dice, cooked half done; equal quantity of peas added; boiled till all are done. Butter-and-flour thickening. CAROTTES A LA MENAGERE—In slices in white sauce with wine and herbs. CAROTTES NOUVELLES A LA SAUCE BLANCHE—Young carrots stewed in white sauce. CAROTTES AU SUCRE—Boiled and mashed, mixed with sugar, milk, salt, eggs, in a dish, sugared over top and browned in the oven. CARROTS IN PUDDINGS—Two oz. grated carrot to each pound of fruit; said to improve plum pudding. Mashed carrot is an ingredient in a pudding on a former page. CARROT SOUPS—About half the soups made contain more or less carrots; they are in all vegetable consommés. "Puree of carrots," "solferino" and "crécy" are carrot soups. Grated carrot has been used to color butter. CARROTS IN CHARTREUSES—They are essential for their color in ornamental vegetable pieces and for salads of cooked vegetables in jelly.

CARP—Fresh-water fish; second-rate in quality, yet has received much attention from the cooks because perhaps of its good shape to serve whole. In season from October to June. BAKED CARP—The gills and backbone, which are the parts tasting unpleasantly of mud in some fish, are removed without quite separating the back; a stuffing of bread and oysters put in, the fish sewed up, egged and bread-crumbed on upper side, and baked; gravy made in the pan with tomatoes or Worcestershire sauce. CARP A LA COBLENTZ—The fish cut in pieces, stewed in stock with Rhine wine, carrots, onions, mushrooms and herbs. Served with the liquor, reduced, lemon juice, butter, parsley, fried bread. CARPE FRITE—Split, floured and fried. GERMAN CARP A LA BIÈRE—Like coblentz, with beer to boil in instead of wine; bits of bacon added. CARPE A LA MARINIÈRE (sea fashion)—Cut up, stewed in white wine and water, garlic, onion, parsley; liquor thick-

## CAR

ened with brown flour and butter; glazed onions, oysters, etc., added. **CARP ROE BALLS**—Roes cooked with salt, vinegar and water 15 minutes, drained, chopped, mixed with bread crumbs, yolks, butter; baked in balls. **COQUILLES DE LAITANCES DE CARPE**—Scalloped carp roe in shells. “In illustration of how much depends upon the dressing of fish, it may be observed that a stewed carp is really a splendid dish; a boiled carp one of the worst brought to table.” (*See Buffalo-fish.*)

**CARTOUCHES DE CUPIDON**—Cartridge-forms of two colors of ice cream; Cupid's cartridges.

**CASSEROLE**—A baked shape of rice; the same thing as *cassolette*, but larger. The rice is boiled dry, then mashed and seasoned, shaped as wanted with a wet knife, the inside hollowed out; exterior decorated, egged over and baked; then filled with a ragout or mince.

**CASSEROLE (Fr.)**—Old name for saucepan. At a fashionable party in Paris: “The *casseroles de ris de veau petits pois* were stews of sweetbread with new peas served in small silver saucepans, the lid being attached to each with a bow of silk ribbon.”

**CASSIA**—The cheaper spice that passes for cinnamon. (*See cinnamon.*)

**CASSIS**—Black currant wine.

**CASSOLETTES**—Little cup-shaped cases of mashed rice, made to hold some kind of meat or sweet filling. They are usually floured and fried; they can be finished by baking as well. One form of rice croquette, which is like biscuit, with a hollow in the center to hold fruit jelly, breaded and fried, is a *cassolette*, but the shapes can be made deep and very ornamental.

**CASSOULET DE TOULOUSE**—“To-day let me merely mention the various ingredients that enter into the composition of *Cassoulet de Toulouse*, as given me by the amiable *chef* of the Café Voltaire: White beans, real Arles sausage, fresh pork, goose, garlic, pounded bacon, pepper and salt; stewed slowly together into a sort of *purée* for five hours. Apropos of *cassoulet*, I noticed, in passing down the Boulevard St. Michel yesterday, a very fine show of fat geese displayed in one of the windows of Boulant's Buillon Restaurant, and over them the intimation, ‘Cassoulet every Saturday.’ The portion is tariffed at 6d.; but not for many sixpences would your correspondent try his feeble digestion with such a dish, delicious and savory though it may be to those endowed with what good old poet Horace calls ‘*dura ilia*.’ At many other Parisian restaurants, by the way, *brandade* and *cassoulet* days are announced in the windows on special showcards. For some reason *brandade* is usually a fixture for Tuesday, while *cassoulet* is almost invariably promised for Saturdays. On such days the restaurants in question are certain to be filled with dark-bearded, *voiable*-tongued, and *sub rosa* be it added, garlic-scented, sons of the South.”

**CASTOR PLANT**—Grown in boxes in dining

## CAT

halls, bar-rooms, etc., it is said to effectually banish flies. The discovery that castor-oil plants possesses the faculty of killing and keeping away flies, mosquitoes and other insects was recently made by a French scientist named Rafford, who noticed that certain rooms in his house, in which castor-oil plants were growing, were entirely free from these disagreeable insects, although other apartments were infested with them. He found lying near the plants large quantities of dead flies, and a large number of dead bodies were hanging to the under-surface of the leaves, which caused him to investigate the matter, and the discovery was made that the plants gave out an essential oil or some toxic principle which possessed very powerful insecticide qualities.

**CATFISH**—The catfish in the United States occupies the same ambiguous position as the conger-eel in England; both are good food and both are subjects of prejudice. The catfish furnishes too much good meat to the markets of all that country that is drained by the Mississippi for its value to be called in question now, and yet a good many people will not eat it. There are several varieties, seeming to be different only in the color of the skin, and some people liking the white, oily, flaky catfish steak compromise with their prejudices by choosing only the yellow cat to eat. But the distinction amounts to very little at the great fish stalls, where cat as large as sturgeon and dear as halibut are cut into steaks by the several hundred pounds daily and sold as readily as any fish from the sea. At the steam-boat landings on the Mississippi it is no uncommon thing for a catfish of 100 pounds weight to be hooked, the fishers using flat-boats to fish from and armed with boat-hooks and axes to cope with such powerful game when hooked; the plan is to get the monster to the side of the boat in one of his quiet intervals and sever the tail with an axe, after which the fish is powerless. The common weights are, however, about 40 or 50 pounds. In smaller streams the fish seem to run smaller, and whole “strings of cats” of small weight may be caught before one that weighs as much as 20 pounds. Nothing elaborate in ways of cooking catfish is known; it is cut into steaks and either broiled or fried. The colored people make soup and chowder of the head. The fish is skinned with a knife, in strips; but small ones are skinned more quickly by scalding and scraping. “Catfish or wolf-fish, which is seen occasionally in the shops, tastes not unlike veal.” It was once proposed to import some varieties of American fish to stock English waters, the catfish among them, and somebody wrote to their *Times*: “In mercy to men and fishes I protest against importing this forbidding, ferocious, uneatable, but all-devouring siluroid.” In reply Mr. Fish-Commissioner Blackford explains that “the fish are not handsome, but they are great favorites in Philadelphia. A native of that place is never so happy as when he is at a pic-nic on the Wissahickon eating catfish and waffles. Not many catfish stray into our market, and when they do they are boxed

## CAT

up and shipped to Philadelphia, where they are appreciated." The catfish is in season from September to April.

CATAWBA—See Wines, Drinks, Ices.

CAULIFLOWER—Grows to perfection in some parts of this country, where the winters are mild and moist, but is a rarity in the corn belt. Florida, Utah and California send shipments of cauliflower to all other sections. As a vegetable delicacy it is only second to asparagus, if carefully cooked.

CAULIFLOWER AND TOMATO SAUCE—The cauliflowers boiled in salted water until the stalk feels soft when tried with a fork, then drained; tomato sauce in the dish it is served in. CAULIFLOWER RABBIT—Cauliflower in small flowerets fried with mushrooms, grated cheese enough to coat it over; served on toast. CHOUXFLEURS AU GRATIN—The flowerets separated after boiling, put in a baking pan or dish; white sauce, grated cheese, and cracker dust sifted over, browned in the oven. CHOUXFLEURS A LA HOLLANDAISE—Boiled and served with Hollandaise sauce. CHOUXFLEURS A LA MAYONNAISE—Cold, sprinkled with vinegar and mayonnaise sauce in the center. CAULIFLOWER SALAD—Cold boiled cauliflower with oil and vinegar. MARIINADE DE CHOUXFLEURS—The pieces parboiled, drained dipped in batter and fried. CAULIFLOWER IN SOUPS—Purée of cauliflower, cream of cauliflower, consommé with cauliflower. CAULIFLOWER PICKLES—Generally mixed with other vegetables; cauliflower is pickled the same way.

CAVY—The guinea pig. Where covies are an article of regular consumption, especially as a substitute for game in the *menu* in the summer season, they are cooked in a variety of ways. They are excellent in various stews as *entrees*, with mushrooms cut up and stewed brown, in a white stew with button mushrooms, with brown onions, with green peas, *a la Soubise*, and especially in curry. The guinea pig or cavy is prepared for cooking the same way as a 'possum, by scalding and scraping the hair off.

CAVIARE—A relish or appetizer popular and fashionable everywhere more than in the United States. It appears in the majority of foreign *menus* whenever the *hors d'œuvres* are named separately. Can be bought in cans at all the fancy grocery stores. To serve, it is spread either upon bread and butter, to make sandwiches, or upon fried bread (croutons). Caviare is greatly eaten in Berlin as a supper dish, served separately on a dish with bread and butter, cayenne and lemon, same as would be eaten with oysters; in London the sandwich is the favorite form. Caviare is as black as ink; it is the salted and smoked roe of the sturgeon, and that is black before it is cured; a large sturgeon will yield a pailful of roe that looks like berries. The comestible seems to be a Russian invention, as it is oftenest branded Russian caviare, though it is made in this country to some extent. TARTINES DE CAVIARE—Spread

## CEL

on buttered toast, decorated with minced pickles, pickled peppers and parsley. CAVIARE SALAD—"Caviare, of course, everybody knows of, and Shakespeare's 'caviare to the general' would have no point to-day. But do you know how caviare salad is prepared? This is a most tasty preparation, and of great delight to the connoisseur. This is how you make it: Take  $\frac{1}{3}$  of caviare and  $\frac{2}{3}$  of bread crumbs and almonds, and mince the whole up as finely as possible with a little olive oil, till the mixture becomes of the color and consistency of mortar. It is very good indeed when eaten with olives."

CAVALIERS BROIL—A boned shoulder of mutton or lamb baked in covered pan, pressed flat while cooking, scored with a knife point, and sauce and seasonings rubbed into the gashes; broiled on the gridiron.

CAYUGA DUCK—The cayuga, like the canvas-back duck, is of great size when mature. Its fine dark flesh is of better flavor than that of an ordinary wild duck, like which it should be cooked. It makes a superb salmi.

CAZANOVA SAUCE—Mayonnaise with chopped yolks, shred whites and chopped truffles.

CEDRAT (Fr.)—Citron.

CELERY—An article of necessity now for every good dinner or supper in the winter and spring. Is thought not to have the delicate crispness so much esteemed until after frost. It should be kept in ice water for a few hours before it is used. The heart stalks are eaten raw with salt. The fashions change as to the method of serving; the tall celery glasses set upon the table form the handiest and handsomest medium, but having become so exceedingly common they are discarded at present at fashionable tables, and the celery is laid upon very long and narrow dishes. It is almost invariably eaten with the fingers. The principal use next made of celery is in salads, or as a salad alone, cut in dice, with oil, salt, pepper and vinegar shaken up in it. CELERI AU JUS—The stalks cut in finger lengths, stewed in stock, served with brown gravy. CELERI A LA VILLEROI—The stalks cut in lengths, parboiled, drained, egged, breaded and fried. CELERI A LA MOELLE—Stewed in stock, served on toast spread with marrow. CELERI A LA CHETWYND—The stalks cut in inch-lengths, stewed, mixed with stewed onions in cream, with chillies; served on toast. CELERI AU PARMESAN—Made the same as macaroni and cheese; the celery in place of macaroni. CELERY SAUCE (white or brown)—Cut in small pieces and stewed, either white or brown sauce added to it; served with fowls and various small meats. CELERY SALT—A most useful kitchen adjunct. It can be made in two ways: 1st, essence of celeri poured over a tablet of table-salt, and the salt then dried, powdered by rubbing one half on the other, and then bottled and closely corked; 2nd, by using ground celery seeds. These are prepared in a pepper-mill and mixed with salt in the proportion of 2 oz. to the 1 lb. of salt.

## CEL

**CELERY PUREE** (a sauce)—Celery cooked and passed through a seive, mixed with cream; served with partridges, quails, chicken, etc. **CELERY SOUPS**—Cream of celery, consommé with celery, and mixed with other vegetables.

**CELERIAC**—Turnip-rooted celery. Eaten raw and in salads; can be cooked as the other kind. **PUREE DE CELERI-RAVE**—Cooked root-celery like mashed turnips.

**CENDRE** (*a la*)—Cooked in the coals.

**CENDRILLONS DU FILETS DE SOLES**—A French *chef's* specialty for a party. "Shape the fillets of soles into the semblance of babies' shoes; bake them for about ten minutes, and, when cold, cover each one carefully with a *sauce chaudfroid*, prepared from the bones of the fish. Decorate what represents the toe-points with a spreading of chervil very finely chopped; and, at the part usually adorned, form a knot of truffles in imitation of a bow. Dish up in a rice-stand, garnished in the center with a *salade Italienne*, and surrounded by *croutons* of fish-jelly."

**CEPES**—These are large or "flap" mushrooms, obtainable in cans put up in oil something after the manner of sardines. They have the mushroom-flavor strong and decided, which is only faint in the canned champignons. Cèpes are valuable additions to entrees and sauces, but are also easily converted into a choice dish by draining from the oil and broiling or frying like an omelet. **CEPES A LA BORDELAISE**—Means Bordeaux cèpes; they only need to be heated in a frying pan and have lemon juice and parsley added. **CEPES A LA PROVENCALE**—The cèpes cut in slices, stewed with garlic, onions, bay leaf and espagnole; lemon and parsley; served with shapes of fried bread. **CEPES OR MUSHROOMS FRESH**—Are prepared *a la Bordelaise* by peeling, washing and draining large mushrooms, steeping for an hour or two in oil, salt and pepper; broiling them, and using the same oil, with lemon juice and parsley, for sauce. "But what struck me the most was the enormous quantity of edible *fungi* that were to be seen about the market at Aix les Bains. They were represented by samples in all their varieties of form, size and quality. The cèpes (esculent *Boletus*), the ordinary mushrooms, the oronges, the morels, the roussillons, etc., were in abundance, presenting a curious aspect with their odd shapes and various colors. But above all I noticed that the cèpes were in majority, their rich tones and glaring colors contrasting strongly with the whiteness of their flesh."

**CEREALINE**—A starchy pudding-material, made from Indian corn. Used same ways as arrow-root, corn starch, tapioca, etc.

**CERF** (Fr.)—Deer, venison.

**CERISES** (Fr.)—Cherries.

**CERVELLES** (Fr.)—Brains. **CERVELLES DE VEAU**—Calves' brains. **CERVELLES D'AGNEAU**—Lambs' brains. **CERVELLES DE MOUTON**—Sheep's brains.

## CHA

**CHABLIS**—A white wine; best kind for cooking fish.

**CHAFING DISHES**—Metal dishes set in another dish containing hot water, a lamp underneath, for keeping meats, etc., hot.

**CHALYBEATE**—Containing iron, as iron spring-water.

**CHAMBERTIN**—A dinner wine. (*See wines.*)

**CHAMBORD** (*a la*)—Style of cooking fish, in which the fish is spread over with forcemeat and decorated, and served with Chambord garnish. Name of a part of France.

**CHAMBORD GARNISH**—Light sauce of fish-liquor, seasoned with vegetables, wine and tomatoes, strained, and mushrooms, fish quenelles, cooked oysters and truffles added.

**CHAMBORD SAUCE**—For fish; made of  $\frac{1}{2}$  pt. white purée of mushrooms, 1 pt. béchamel, 2 oz. lobster butter, a glass of sauternes and piece of glaze.

**CHAMPAGNE**—A wine accidentally discovered by a good Benedictine monk, named Dom Perignon, in or about the year 1688. (*See wines for times to serve, etc.*) "SWEET *v.* DRY CHAMPAGNE—It is for the interest of the wine manufacturer that a taste for a very sweet wine should predominate in the world. A dry champagne, to be palatable, must be made of the finest raw wine. A sweet champagne can be made of almost any material. The excessive quantity of sugar in the latter masks completely its original character. In the former, every natural feature is distinctly expressed, and its virtues or vices, if it have them, are at once discerned. Champagne, as it is known to the consumer, the *vin prepare* (prepared wine) of the manufacturers, does not improve by age. The wine, the *vin brut* (raw), of which it is made, provided it be good, does, however, benefit by increase of years. **EFFERVESCENCE**—The effervescence of champagne depends much upon the form and condition of the glass out of which it is drunk. It sparkles much more freely when poured into a glass pointed, than in one that is round or flat at the bottom. The presence of a little dust, left by a careless waiter, will increase greatly the development of the gas; and the glass that, after being rinsed with water, is wiped with a cloth, however fine, will cause the champagne poured into it to sparkle, while the same wine will be comparatively still in the glass which has been merely rinsed and untouched afterwards. **STORAGE**—As soon as the consumer has purchased his stock, he should remove the bottles from the baskets or cases, and lay them in a cellar of about 45 degrees, on their sides, with an inclination of the neck downwards, so that the wine may remain in contact with the corks. Thus, constantly bathed with the vinous fluid, they are prevented from drying and shrinking, and from being covered with mould, which will spoil the flavor of the best champagne. If the cork shrinks, from dryness and heat, the gas will escape, and the wine,



## CHA

losing its sparkle, become flat. **EXPLOSIVENESS**—The champagne which explodes the loudest and flows out the frothiest, is by no means the best. It is, in fact, a proof of its inferiority. Good wine largely absorbs the carbonic-acid gas generated in the course of its manufacture. In bad wine the gas, instead of being absorbed, accumulates in the vacant space above the liquid, and thus, when the bottle is opened, the cork explodes with great violence, followed by a cataract of froth. When this escapes, the wine remains comparatively flat. In good wine, on the other hand, the cork may require a great effort to draw, and when drawn there may be little or no froth, but the liquid will be seen to sparkle with innumerable gems of brightness." **CHAMPAGNE DRINKING**—"The prevalent notion that a glass of champagne cannot be too quickly swallowed is erroneous; and it is no bad test of the quality of champagne to have it exposed for some hours in a wine-glass, when, if originally of the highest order, it will be found to have lost its carbonic acid, but entirely to retain its body and flavor, which had before been concealed by its effervescence. Champagne should, therefore, not be drunk till this active effervescence is over, by those who relish the above characteristic quality."—"The reason champagne is costly is not that the grapes from which it is made are less prolific, or require more expensive treatment to vinify than other sorts; it is the amount of care and attention required after bottling that makes the price so high. A bottle of champagne, or other kindred wines, requires, without exaggeration, twenty times the labor and care of any other, and in addition a heavy percentage is annually lost through the bursting of bottles during manufacture, which proportion of breakage rises as the quality of the vintage is more favorable, in good years reaching from ten to twenty-five per cent.—bottles and wine entirely lost—and yet the sale of champagne continues to be both large and remunerative to the grower, and he, to meet the demand, extensively adulterates and doctors inferior qualities, as is proved by the excess of that consumed over that produced; but from the above remarks it can be gathered that there is no such thing as cheap champagne, and when champagne is offered below a certain figure, one may rest assured it is not champagne at all."

**CHAMPAGNE CAKES**—Peculiar shapes of cake, like the natural divisions of an orange, made of 1 lb. sugar, 1 lb. butter, 9 eggs, 1½ lbs. flour; mixed like pound cake. Stiff paper folded in flutings like a fan, spoonfuls of the cake dropped at distances apart.

**CHAMPAGNE CIDER**—Cider bottled and kept one or two years.

**CHAMPAGNE FRAPPE**—Bottles of champagne set in a pail of freezing mixture (pounded ice and salt) until thoroughly cold and beginning to freeze, like melting snow. "Mr. Henry Clair is an ingenious man. A contemporary says of him that

## CHA

he can *frappe* a bottle of champagne in five minutes. He puts into a metal wine cooler a bottle of champagne, surrounds it with alternate layers of ice and rock salt, and puts the cooler on a hot range, turns the bottle with the hands, and the rapid melting of the ice solidifies the wine at once."

**CHAMPAGNE CREAM**—Cream-colored, sort of champagne egg-nogg; yolks of eggs and powdered sugar—5 yolks and 5 oz. to a bottle—whipped light, champagne and brandy added; half frozen, served in punch glasses.

**CHAMPAGNE SAUCE**—Sauce made by mixing gooseberry or apple champagne with brown sauce and little sugar; served with roast ham.

**CHANNEL BASS**—The redfish of the South, or sea bass. It is known by its having a black spot on each side of the tail; attains a weight of ten or fifteen pounds; is cooked like snapper and any sea fish.

**CHANCELLOR PUDDING**—A steamed cabinet pudding made of sliced small sponge cakes, macaroons, raisins, citron, in a buttered and ornamented mould; filled up with custard before steaming.

**CHANTILLY CREAM**—Whipped cream; common thick cream; possibly it may have meant at first clotted cream. French royalty had a country residence at Chantilly about the time our present culinary terms were in course of formation, and there also was the royal model farm and dairy, whence came the "chantilly cream" for the king's table in Paris. The term occurs with great frequency with certain culinary authors, and never means anything else than whipped cream. **MERINGUE BASKETS A LA CHANTILLY**—Egg-kisses built up in basket shape by sticking together with candy; the basket then filled up with sweetened and flavored whipped cream. **BORDER OF JELLY A LA CHANTILLY**—Same as English jelly with syllabub; a border or ring of jelly formed in a border mould, turned out and the center filled up with whipped cream. **GATEAU A LA CHANTILLY**—A cake made hollow in the middle, spread all over with jam and filled with whipped cream. **CHANTILLY SOUP**—Purée of young green peas, slight flavor of mint and green onions.

**CHAPON** (Fr.)—Capon.

**CHAR**—Fish like a trout, or the cisco of the American lakes; found in the lakes of the north of England; cooked, potted, etc., like brook trout.

**CHARCUTIER**—(Fr.)—Pork butcher.

**CHARCUTERIE** (Fr.)—The pork butchers' manufactures; products of pork and other meats, such as *Strasbourg cervels*; *Nancy chitterlings*; *andouillettes*, *saveloy pig's liver*; *pig's feet with truffles*; *rillettes de Tours*; *boudins*; *cervelatwurst*; *schinkenwurst*; *plockwurst*; *Frankfurt wurstchen*; also brawn, galantines, etc.

**CHARCOAL**—The best deodorizer; best non-conductor of heat for refrigerators if finely pounded;

## CHA

necessary for broiling meats. A supply for a hotel can generally best be obtained by engagement with a countryman to burn a pit, as it is called, though some make a business of it and go around and take orders. The tinsmiths have to have it, and can often direct a steward where to buy. The price of charcoal ranges from 7 or 8 to 15 cents per bushel in ordinary localities. Charcoal should be kept dry. The dust remaining is good and useful to destroy the smell of chicken coops, waste barrels, tainted meats, etc.

CHARLOTTE—A sweet dish made of a casing of cake or bread, the inside of fruit or cream. APPLE CHARLOTTE.—See apples. CHARLOTTE DE POIRES—Pear charlotte.

CHARLOTTE AUX FRUITS—Several kinds of fruit stewed with wine in a charlotte made same as with apples.

CHARLOTTE RUSSE—Not to be confounded with *chartreuse*. Charlotte russe is varied in several ways; it is a lining of either lady fingers or sliced sponge cake, placed around the inside of a mould and filled up with a cream containing gelatine enough to set it, pure whipped cream is the best, sweetened and flavored. Small charlottes to be served individually are made in muffin rings and turned out when set, or in fancy paper cases and served in them, when whipped cream without gelatine is sufficient. CHARLOTTE A LA POLONAISE—A sponge cake cut in slices, the slices dipped in flavored cream and built up into their former shape; the re-formed cake is covered with whipped cream and sugar and decorated with jelly; served very cold.

CHARLOTTE PRUSSIENNE—A charlotte russe solidified by partial freezing, wine jelly being poured in the mould first  $\frac{1}{2}$  inch deep, lady fingers around when that is set; filled up with Bavarian cream and set in a pail of freezing mixture till wanted.

CHARLOTTES GLACEES—Frozen charlottes; made by lining a mould with lady fingers and filling with ice cream; the name according to the filling; as CHARLOTTE GLACEE A LA PLOMBIERES—Is filled with a white tutti frutti. A wetted paper is first to be laid in the bottom of the mould. INDIVIDUAL CHARLOTTES GLACEES—Square cases made of 4 sponge drop biscuits joined at the ends with icing, filled at serving time with ice cream.

CHARTREUSE—A liqueur invented by the monks of Chartreuse. Can be bought of liquor merchants, as well as maraschino, etc.; is used by pastry cooks in ices and creams. There are four varieties of the liqueur mentioned; the yellow chartreuse is that in common use at first-class bars. "Chartreuse is of four kinds: The 'Elixir,' which is most expensive, and, if genuine, has a slight flavor of bitter orange. The 'Green Liqueur,' which my friend 'Drogan' uses for his high-class creams, has a pronounced flavor of Angelica. Much of its

## CHA

medicinal, blood-cooling and healing qualities are due to the extracts of garden balm, wild thyme, sea-pink flowers, spearmint, red clove carnations, violets, and the young tassels of the pine-trees. There are many seeds also used in its composition, such as coriander, orange pips, cucumbers, almonds, pistachio nuts, etc. The green chartreuse is the most popular of the four kinds, and a small glass of this liqueur, with a dash of Cognac in it, is one of the finest after-dinner stomachics a man can have. The yellow chartreuse stands next in order, and is more popular on the Continent than in this country. It is far from being so spirituous in character as the green chartreuse, averaging from 12 to 14 degrees of alcoholic strength. Next comes the far-famed 'Balm' chartreuse, which is of a very pale straw color, one might almost term it white. Here the garden and other balsams predominate; its qualities are nerve-soothing, healing and cooling."

CHARTREUSE—An ornamental mould of vegetables, either cold or hot. (See illustration on page 117.) A cold decorative chartreuse is made by cutting cooked vegetables of different colors into blocks, heating them in aspic jelly and building them in patterns upon the interior of a mould, and filling the inside with green peas in jelly or any similar material. CHARTREUSE A LA MIKADO—Forcemeat of chicken, highly seasoned with aromatic salt, is filled into rings of sliced cooked carrots and beets, dipped in jelly and a mould lined with them; filled up with chicken and green peas in jelly. CHARTREUSE HOT—A small mould lined with blocks of cooked carrots, turnips and beets, the interior filled with well-seasoned cabbage drained and chopped, or with potato, parsnip, etc. Made hot and turned out on a dish.—The chartreuse of vegetables derives the name from the same monks of Chartreuse to whom the chartreuse liqueur is credited; it was one of their fast-day dishes, and strictly made is entirely of vegetables. There is a malicious story, however, in circulation that the good men, having the inside of their ornamental dish filled with cooked cabbage, excellently seasoned, rolled up and systematically placed in rows, used to find a boneless joint of a partridge rolled up in each leaf, like the filling of a cigar, and regarding it as a miracle ate the meat in silence. CHARTREUSE OF PARTRIDGES—Cooked joints of partridges imbedded in the cabbage of the hot chartreuse before described. CHARTREUSE OF LAMB AU GASTRONOME—Breast of lamb, cooked and pressed, cut in blocks; cooked heart lettuce; the two filled in a mould in alternate order, pressed in, made hot in steamer; turned out, and served with white sauce. LINING FOR CHARTREUSE—Is best made by cutting the vegetables, either cooked or raw, with a column (tube) cutter like bottle corks, the ends showing outside, the length giving room to build upon. CHARTREUSE AUX POULETS A LA REINE—A delicious, but rather expensive entrée, the wall of the chartreuse being formed of small circles alternately of truffles and tongue.

## CHA

CHASSEUR (Fr.)—Hunter.

CHATAIGNES (Fr.)—Chestnuts, the small kind. *Marrons* are large chestnuts.

CHATEAUBRIAND—Name of a French statesman. First applied to fillet beefsteaks cooked between two ordinary steaks, their juice being squeezed over it for sauce; now it has come to mean simply a fillet (tenderloin) of beef, or slice of the fillet, with Chateaubriand sauce. CHATEAUBRIAND SAUCE—Brown meat gravy, or beef extract, mixed with butter, parsley and lemon juice.

CHAUD (Fr.)—Hot.

CHAUD-FROID (Fr.)—Literally hot-cold. The term has a definite meaning in cookery, being the name of a certain sort of jellied sauce; still it is one of the odd names which the French themselves cannot give a reason for. It is supposed, however, that it took its name from Cardinal Mazarin's famous cook, who invented it; his name was Crauffroi (that name is the original of Geoffroy and Jeffrey). Another story has been told in regard to it, that it originated with the proud and haughty Duke de Rohan, of great repute as an epicure in his time, who, while at dinner, was sent for in haste by the king and ordered his favorite dinner of fricasséed chicken to be reserved till his return. When afterwards it was served to him again he complained that it was *ni chaud ni froid* (neither hot, nor cold), yet praised it for its richness so much that his imitators took the hint, and the dish had a run. CHAUDFROID SAUCE—Is a rich gravy, made by boiling down game or poultry with aromatics, and after straining adding enough gelatine to make it bright-brown jelly, or, rather, a jellied gravy. CHAUDFROID OF PARTRIDGES—The cooked meat cut in dice, warmed in chaudfroid sauce, stirred about until cold; served cold in *caisses*, *croustades*, *casseroles*, rolls, paste shells, patty cases, etc. Other meats the same way, but the sauce is made cream-white for chaudfroid of chicken. CHAUDFROID OF RABBIT—After roasting or stewing, the rabbit is cut into joints, bones taken out, and warm cooked sausage meat inserted. When cold, the pieces are covered with chaudfroid sauce; served with border of endive. CHAUDFROID OF EGGS—Hard-boiled eggs, an opening cut in the side, and yolks extracted; mince of truffles, tongue, chicken and mushrooms in thick sauce filled into the whites; aperture stopped, eggs covered with chaudfroid sauce, cold; served with aspic.

CHEDDAR—An English variety of cheese.

CHEESE—Served in small squares and almost invariably eaten with the fingers. The last course of a dinner, but often in the form of *canapes* and other made dishes, appearing as well among the hot *hors d'œuvres* near the beginning. A chemist has been wrestling with the difficulty of the indigestibility of cheese in the case of weak stomachs, and claims to have made the discovery that a  $\frac{1}{4}$  oz. of bicarbonate of potash in a pound of grated cheese

## CHE

stirred over the fire with some milk till it dissolves, makes a soluble cheese that is easily digested. HYGIENIC CHEESE CUSTARD—Cheese with milk and potash as named; mustard, pepper, salt, and eggs. poured like an omelet in hot buttered dish, and baked. CHEESE PUDDING—Same mixture with more milk, poured to a dish of slices of bread, and baked. WELSH RAREBIT—Original recipe:  $\frac{1}{2}$  lb. cheese in small bits,  $\frac{1}{2}$  glass ale, lump of butter mixed by stirring over a brisk fire, pepper, salt, and dry mustard added, poured over squares of toast. POTTED CHEESE—Dry pieces of cheese pounded fine with  $\frac{1}{4}$  lb. butter for every pound; pepper, cayenne, dry mustard; pressed down into jars to keep for sandwiches and cheese toasts. CHEESE FRITTERS—Grated cheese, bread crumbs and eggs beaten well together; fried in small lumps of butter. CHEESE TOAST—Cheese and butter melted together, on fried bread. CHEESE AND MACARONI—One way of doing it in individual style is to place the cooked macaroni in the dish, dredge grated cheese and bread crumbs over, and brown each dish as it is sent in with the salamander. Ordinary macaroni and cheese has layers of macaroni, cheese sprinkled over, a sauce poured in, crumbs or cracker dust on top, and baked brown. There are other ways, however; the ordinary hotel *Macaroni and Cheese a la Genoise* is but boiled macaroni with grated Parmesan (which comes ready-grated in bottles) dredged over and a spoonful of tomato sauce besides. CHEESE SOUFFLES—Made of  $\frac{1}{4}$  lb. soft cheese, 2 oz. flour, 1 oz. butter, salt, cayenne; all mixed with 3 yolks and the whites whipped to froth; baked in cases or cups. Must be served hot. CHEESE BALLS—Whites of 2 eggs whipped stiff, 2 oz. Parmesan cheese grated (or other dry cheese), stirred together, salt, cayenne, dropped in hot lard and fried like fritters; served very hot. BAKED CHEESE (restaurant specialty)—Four oz. butter,  $\frac{1}{2}$  pint water boiled, 7 oz. flour stirred in; when partly cooked, 4 yolks beaten, then 4 whites whipped, 4 oz. grated cheese; poured in dish, covered with very thin slices of cheese; egged over; baked. KINDS OF CHEESE—Of 18 varieties experimented with, Cheddar cheese was found to be most easily digested, 4 hours; skim Swiss cheese requires 10 hours. Fat cheeses are most digestible. CHEESE WITH ASPARAGUS—Cheese assimilates deliciously with most varieties of succulent vegetables, and is particularly good with asparagus. Some Parmesan or Gruyère should be grated over the soft part. CHEESE STEWED WITH ALE—Is much easier of digestion than when toasted. The only *post-prandial* dish of the Beef Steak Club used to be a stew of cheese in a silver dish. CHEESE WITH CUTLETS—Lamb or mutton chops are dipped in flour, beaten egg, grated cheese and cracker dust, and fried *a l'Italienne*. CHEESE STRAWS—Crisp sticks of cheese-paste made of 4 oz. each butter, cheese and flour pounded together, little water to moisten, salt, cayenne; cut in strips and baked; tied in bundles with colored ribbon. They are cut from size of

## CHE

straws to broad strips. **PARMESAN PYRAMIDS**—Square pieces of cheese-straw paste baked; whipped cream mixed with grated Parmesan on top. **CHEESE RAMEQUINS**—Light cheese soufflé baked in cases, made of 2 oz. butter, 1 oz. flour, 1 cup milk, 6 eggs, 6 oz. grated cheese; baked. **FRIED RAMEQUINS**—Puff-paste rounds spread with grated cheese wetted with cream, doubled over, edges pinched; fried. **CHEESE TRIFLES**—Small patty-pans lined with paste, cheese, cream, and egg yolk mixed for filling. **CHEESE OMELET**—An ordinary omelet with grated or minced cheese stewed over and rolled up in it. **CHEESE SOUFFLE**—A little thick butter-sauce with grated cheese, yolks and whipped whites; baked in a pan or case. **CHEESE FONDU**—Melted cheese, butter and eggs stirred up together. **PAILLES AU PARMESAN**—Cheese straws. **PAILLES A LA SEFTON**—Strips of puff-paste with grated cheese between the layers rolled in; egged over and baked. **BISCUITS AU FROMAGE**—The same paste of which cheese straws are made, cut into squares or diamonds. **PAIN DE FROMAGE**—A cheese cream, made of custard with salt and cayenne instead of sugar; 3 oz. grated cheese stirred into  $\frac{1}{2}$  pint of the custard and  $\frac{1}{2}$  pint whipped cream, and  $\frac{1}{2}$  oz. gelatine to set it when cold. In a mould.

**CHEESE-CAKES**—Are not made of cheese, though the best of them are made with a proportion of the same curd of which the cheese is made; milk, curdled with rennet and drained in a cloth, is mixed with sugar, eggs, almonds, etc., and baked in patty pans lined with paste. They are small custard-tarts. They are all those things which the French call *fanchonettes*, *mirletons*, *darioles* and various other names grouped under one denomination in English. All the pie mixtures used in the United States, such as cocoanut pie, lemon pie, apple cream, orange cream, cheese-curd pie, bread-custard pie, etc., if baked in small pie pans or patty pans, are English cheese-cakes. (*See cream cheese.*)

**CHEF-DE-CUISINE** (Fr.)—Chief of the kitchen; chief cook; steward who cooks, or directs the cooking operations, as the case may be.

**CHELONIAN**—Scientific name for turtle, sometimes used as a synonym.

**CHELSEA BUNS**—Sweet coiled rolls, made of flour, milk, sugar, butter, yeast and yolks; the dough rolled out and spread with butter, rolled up and cut off in inch-thick pieces to make buns which will part in coils where the butter is. Sugared over.

**CHELTENHAM PUDDING**—A baked plum-pudding, made of 6 oz. each suet and flour, 3 oz. each bread crumbs, sugar, currants, raisins, 2 eggs, powder, nutmeg, milk to mix it to stiff batter.

**CHERRIES**—For hotel use the cherries ready-stoned should be bought; they are solid fruit and serviceable, and otherwise cherries are seldom pitted and pies not good. White California-cherries are a luxury for supper fruit and for ices. **CHERRY PIE**—Red or black are the best; can be used whole or raw

## CHE

in pies, same as apples or blackberries, well heaped up, or stewed, in less quantity. **CHERRY ROLL**—Pitted cherries rolled up in a sheet of biscuit dough, tied in a cloth, steamed, boiled or baked. **CHERRY PUDDING**—In a bowl lined with paste and covered after filling with cherries. **CHERRY COBBLER**—A large pie baked in a pan, cut out in squares; served with the syrup. **CHERRY MERINGUE**—Stewed cherries spread  $\frac{1}{2}$  inch deep on a sheet of cake; whipped whites with sugar on top; light baked. **CHERRY ICE-CREAM**—White cherries mixed in pure cream and sugar, and frozen. **CHERRY-WATER ICE**—Red cherries stewed, strained; juice only mixed with thin syrup; frozen. **CHERRY ICE**—Cherries lightly cooked; juice, water and sugar frozen; whipped whites beaten in; cherries added at last. **CHERRY SHERBET**—Whipped whites beaten in water ice after freezing. **FROSTED CHERRIES**—Ripe cherries dipped in whipped white of egg and rolled in powdered sugar; dried on sieves or paper. **CHERRY JELLY**—Gelatine jelly made with red-cherry juice and whole white cherries in it. **FLAN DE CERISES**—Open cherry pie with custard on top of the fruit; cherry tarts, turnovers, vol-au-vents, etc., same as other fruit. **CHERRY FRITTERS**—Cherries stewed to preserves, a spoonful between two very thin slices of bread, dipped in batter, fried, sugared over.

**CHERVIL**—One of the garden herbs used in cooking. These herbs will grow in any garden, and seed is obtainable at the large city seed-stores.

**CHESTERFIELD CAKES**—A variation of lady-fingers, having caraway seeds sprinkled on top.

**CHESTER PUDDING**—A meringued cheese-cake, or *fanchonette*, made of equal parts sugar, almond paste, butter and raw yolks, mixed with little lemon rind and juice; baked in a crust; frosted over.

**CHESHIRE CHEESE**—English cheese of the same style as the staple York State and Western Reserve cheese of this country; large, medium rich, yellow, and generally of fine flavor.

**CHESTNUTS**—There are two sorts; the small kind are too tedious peeling to be of much use in cooking; the large ones are known as Italian. They are good food when cooked; can be made up in many ways. The best sweet potatoes have very nearly the same flavor as chestnuts, and are often substituted for them wholly or partly in chicken stuffing and purées. **CHESTNUTS BAKED OR BOILED**—If the truth were known, many persons would confess that chestnuts never look so tempting as when they are seen at the corner of a street on the rude baking contrivance of a vagabond roaster. If they only had the courage in the face of day, they would gladly stop to buy a pennyworth and consent to pay a shilling. Nobody has been known to feel in the same way to boiled chestnuts, unless it be the Portuguese and those who have learnt their style, which is to "top" them, that is, nip off their points, and to boil them with aniseed—half an ounce to fifty chestnuts. **CHESTNUTS FOR TURKEY**—They are boiled, peeled

## CHE

and scraped, put in the turkey whole, but a little seasoned forcemeat mixed in with them to hold the seasonings and absorb the gravy of the roasting fowl. **CHESTNUT FORCEMEAT**—That which is named in the bills of fare as *purée de marrons*, and is often made of sweet potatoes. If made genuine, it is pounded chestnuts, butter, bread crumbs, grated ham, onion, lemon rind, egg yolks, salt and pepper. Used to stuff chickens or any fowl, or sucking pig. **PURÉE OF CHESTNUTS**—Like mashed potatoes, strained through a sieve; served with turkey wings and various entrees. **CHESTNUT SOUP**—A cream soup thickened with purée of chestnuts. **COMPOTE OF CHESTNUTS**—Boiled and peeled, simmered in syrup, flavored with lemon or orange; served hot or cold, with pastry. **CHESTNUTS AS A VEGETABLE**—Boiled, peeled, fried a little to remove the husk; stewed and served in various ways as other vegetables. **CHESTNUT PUDDING**—Purée of chestnuts and butter, corn starch, eggs, almond paste, sugar, milk, lemon; baked or steamed. **SOUFFLE OF CHESTNUTS**—Purée of chestnuts with sugar, vanilla and white of an egg; made into very small balls; dipped into white of egg and sugar twice; dry-baked in a slow oven. **CHESTNUT FLOUR**—“One may often wonder, in reading some of Ouida’s novels, at the number of times she mentions chestnuts as a food of the Italians, particularly those of Tuscany. The Greeks and Romans used this kind of food, and at one time the Arcadians subsisted almost wholly on this farinaceous nut. In many parts of Italy its flour is used in preference to that of wheat or corn. The nuts are ground into flour in the same manner as wheat and corn, and from this flour various dishes are made, as well as cakes, fritters, and even bread, and it is sweet, agreeable to the taste, and healthy.” **POUDING AUX MARRONS**—A mould of chestnut flour, butter, milk, eggs, sugar, vanilla; it is served with apricot syrup. **CHATAIGNES CROQUANTES**—Same as *souffle* above. **GATEAU DE MARRONS**—Same mixture steamed as a pudding. **MARRONS A LA CREME**—Minced chestnuts covered with whipped cream. **MARRONS GLACES**—Candied chestnuts. **DEVILLED CHESTNUTS**—Same way as salted almonds; peeled, thrown into hot clarified butter, salt and cayenne; fried yellow or light brown.

**CHEVRETTES (Fr.)**—Prawns; large shrimps; the Barataria shrimps.

**CHEVREUIL (Fr.)**—Roebuck; venison.

**CHICORY**—Green salad; endive; curled endive; succory. There are two or three varieties, not more different than varieties of lettuces. **CHICORY WITH GRAVY**—Chicory cooked like spinach or greens. **CHICORY ROOT**—The great coffee-adulterant. Those who do not care for the loss of the stimulating qualities of coffee learn to like the taste of the chicory mixture. An act was once passed to prohibit the adulteration with chicory, but the consumption of coffee afterwards decreased; it was found that people wanted chicory in their coffee, and the act was re-

## CHI

scinded. The mixture is about one-fourth chicory to three-fourths coffee. Chicory is cultivated as a field crop; the roots are dried, roasted, ground; can be bought in packages separately and mixed to suit. It is about one-third the price of coffee. The mixture cannot easily be detected when there is milk in the coffee; but those who drink coffee without milk or cream become aware of the presence of chicory at once. “Anent chicory in coffee I have an anecdote to tell. President Grévy loves his Mocha better than most men, and as a consequence hates the name of chicory as much as we may suppose him to hate the name of Prince Bismarck. Accordingly, when he ever goes into a country inn or hotel, he asks the waiter if there is any chicory in the house. The waiter brings him some. ‘More, more!’ cries the President; ‘I want lots of chicory—lots.’ This he repeats, until the waiter answers in despair that there is not another grain of chicory left in the house. ‘Well, then,’ says the President, ‘you may make me a cup of coffee now.’” Chicory is not in general use in the United States; most people are in the habit of buying their coffee in the berry, and either grinding it or having it ground by the grocer. Chicory in separate form, when wanted, can be bought ready, put up in convenient packages, at all the large grocery stores.

**CHICKEN**—In the United States chicken is the name commonly applied to fowls of any age, the word fowl being but seldom used; and this practice has been so extended that it takes in “prairie chickens” and “guinea chickens.” **SMOTHERED CHICKEN**—Home fashion of braising; halves of chicken cooked in a covered pot with live coals on the lid; fat and seasonings cooked with the chickens, and gravy made of the remaining liquor. Imitated by baking with sauce in the pan in the oven; the chickens floured on top. **FRIED CHICKEN**—Joints rolled in flour and cooked in a kettle of hot lard. **CHICKEN A LA MARENGO**—Cut up in joints, rolled in flour, fried in oil, sauce made in the pan, the oil remaining in it; dished in pyramid form, and sauce poured over. “On the evening of the battle of Marengo, the First Consul was very hungry after the agitation of the day, and a fowl was ordered with all expedition. The fowl was procured, but there was no butter at hand, and none could be found in the neighborhood. There was oil in abundance, however; and the cook, having poured a certain quantity into his skillet, put in the fowl, a clove of garlic and other seasoning, with a little white wine, the best the country afforded; he then garnished it with mushrooms, and served it up hot. This dish proved the second conquest of the day, as the First Consul found it most agreeable to his palate, and expressed his satisfaction. Ever since, a fowl à la Marengo is a favorite dish with all lovers of good cheer.” **FILETS DE VOLAILLE A LA DUMAS**—Breast of chicken, each one cut in two raw, spread with a purée of cucumbers in white sauce, breaded and fried; served on a purée of cucumbers. **FILETS**

## CHI

DE VOLAILLE AUX CONCOMBRES—Breast of chicken breaded, arranged on the dish with stewed cucumbers, and purée of cucumbers for sauce. FILETS DE VOLAILLE A LA NESSELRODE—Breasts of chickens served cold, masked with a white chaudfroid sauce; alternately with glazed slices of tongue and chopped eggs, a mayonnaise salad in center. FILETS DE VOLAILLE AUX POINTES D'ASPERGES—Hot dish; breasts of fowl coated with white supreme sauce ranged around a pile of asparagus-points in center of dish; alternating with slices of tongue. SUPREME DE VOLAILLE AUX TRUFFES—Breast of chicken coated with white supreme sauce ranged around a pile of truffles cooked in wine. SUPREME DE VOLAILLE A LA ROYALE—Breasts of chickens coated with white supreme sauce, a slice of black truffle on each, ranged upon an ornamental border of vegetables heaped in the center. CHAUDFROID DE FILETS DE VOLAILLE AU SUPREME—Cold dish; breasts of chickens coated with white supreme sauce, decorated with truffles, ranged around a center of truffles in chaudfroid sauce. SAUTE DE FILETS DE VOLAILLE A LA CARDINAL—Hot dish; breast of chickens fried in butter, slices of truffle stewed in wine alternating in the dish; cardinal sauce in the center. FILLET OF CHICKEN A LA DAUPHINE—Breasts of chickens laid open, forcemeat inclosed, rolled up, covered with pork slices, simmered in butter and broth, dished on shape of fried bread; truffle sauce. CHICKENS A L'IVOIRE—Chickens ivory-white; chickens cooked with sliced lemon and fat salt pork on the breast in seasoned broth, white supreme sauce poured over; red tongue for garnish. CHICKENS A LA CHIVRY—Boiled in seasoned broth; served with green herbs in rings of onion parboiled, and ravigote sauce. CHICKEN A LA PROVENCALE—Cut up, fried in oil with garlic and seasonings, sauce of espagnole, wine and tomatoes, lemon juice and parsley. POULETS A LA TARTARE—Breaded, broiled; served with tartare sauce and pickles. POULETS SAUTE AUX TRUFFES—Cut up, fried in butter; served in brown sauce with truffles. POULETS A LA PROVENCALE—Cut up in a pan; garlic, onion, oil, herbs; white wine to moisten, white sauce poured over, bread crumbs on top; browned in the oven. POULETS A L'ORLY—Cut up, dried, dipped in thin batter, fried; served with rings of onions floured and fried. POULETS A LA BONNE FEMME—Stewed in white sauce. POULETS A LA CHASSEUR—Marinated in oil, lemon juice, onions, herbs; breaded, broiled; served with wine sauce with chopped ham. POULETS EN KARI—Curry of chicken. FRITOT DE POULET—Cut up, marinated in oil with seasonings, floured and fried; tomato sauce. FRICASSEE DE POULET—Stewed in white sauce with mushrooms. FRICASSEE DE POULET A L'ANCIENNE—Stewed in cream sauce with spring onions. CHICKENS A LA MONTMORENCY—Stuffed with forcemeat, sweetbreads, truffles and mushrooms minced; breasts larded, roasted in the oven; sauce with espagnole in the pan; garnish of sweetbreads and mushrooms. CHICKENS A LA ST.

## CHI

CLOUD—White dish, with red tongue and black truffles inserted in the breasts, and pork slices over; simmered in broth; white supreme sauce. FILETS DE POULARDES AU SUPREME—Breasts of fowls simmered in seasoned stock with butter, in a circle in the dish; supreme sauce over. FILETS DE POULARDES AUX CHAMPIGNONS—Covered with cream sauce with mushrooms. FILETS DE POULARDES A LA DUCHESSE—Chicken breasts flattened; half of them larded, braised, glazed; half plain sauté; dished alternately in a circle, cream sauce with cock's combs in the center. EPIGRAMME OF CHICKEN A LA MACEDOINE—Imitation of cutlets made with the breasts flattened, breaded, bones inserted, fried; imitation cutlets made of the legs, boned, stuffed, sewed up, pressed, simmered, with gravy; dished alternately in a circle, macedoine in the center. FILETS DE POULARDES A LA TALMA—The breasts divided into upper and minion filets (natural division), larger ones larded, braised, glazed; minion filets studded with green string beans and fried in butter; spinach in center, brown sauce under. FILETS DE VOLAILLE A L'AMBASSADRICE—Breasts sliced, forcemeat spread, smoothed, shaped, egged over, half of them covered with chopped truffles and breadcrumbs, others with chopped ham and breadcrumbs, cooked in sauté pan in the oven, served with purée of cucumbers. ASPIC DE POULET A LA PRINCESSE—Cold ornamental dish, cooked breast of chickens in oval slices, covered with jelly singly spread in a dish, cut out with a cutter when set, each slice with the jelly coating it; served with salad and aspic border. COTELETTES DE VOLAILLE A LA DAUPHINE—Legs of chicken with thigh-bone removed, steeped in oil, breaded, fried, served with vegetables in the center and cream sauce. CUTLETS OF CHICKEN A L'ALLEMANDE—Minced raw chicken meat and pieces of cooked chicken in small squares mixed together, red tongue, mushrooms and seasonings mixed in, making a chicken sausage meat. Shaped like cutlets, cooked in saucepan with butter, cooled, pressed, breaded, fried, chicken bones inserted; Allemande sauce. CUTLETS OF CHICKEN A LA VILLEROI—Minced cooked chicken made up as for croquettes, shaped, dipped in the sauce of onions, parsley, flour, yolks, butter, broth, etc., breaded and fried; tomato sauce. CUTLETS OF CHICKEN A LA MONTPENSIER—Breasts of chicken, raw, chopped, mixed with butter and cream, shaped like lamb chops, breaded, fried one side at a time in little butter; tomato sauce. CHICKEN SAUTE A LA PRINTANIERE—Cut up, fried in clear butter; sauce of white wine and espagnole, green peas and string beans mixed in, poured over chicken. SALADE DE FILETS DE VOLAILLE A LA BRUNOW—Cold dish; a white aspic of cream and jelly, chicken meat, slices of cooked cucumber and green peas, cut out when cold and set served on a salad border with white tartar sauce. CHARTREUSE DE VOLAILLE—Cooked pieces of chicken in forcemeat in a mould lined with vegetables. CREME DE VOLAILLE—Purée of chicken

## CHI

mixed with cream sauce and eggs, steamed in a mould lined with truffles and tongue—a chartreuse. **PETITS SOUFFLES DE VOLAILLE**—White meat of chicken, pounded, passed through a seive, mixed with butter, cream, yolks, whipped whites, baked in small paper or paste soufflé cases. **SOUFFLE GLACE DE VOLAILLE**—Frozen mould of chicken salad with whipped jelly. **QUENELLES DE VOLAILLE**—Pounded white chicken meat, with seasonings made up in olive shapes, poached, or breaded, and fried; served with dressed vegetables. **QUENELLES DE VOLAILLE EN DEMI-DEUIL**—Chicken forcemeat balls in half-mourning; white quenelles, half of them poached, half rolled in chopped black truffles; served with white suprême sauce and black truffle garnish. **QUENELLES DE VOLAILLE A LA RUSSE**—Quenelles of fine chicken-forcemeat, oval, flattened, with oval slices of tongue to match in size, glazed; dressed in a crown (*en couronne*) alternately; sauce suprême. **BOUDINS DE VOLAILLE A LA LUCULLUS**—Quenelles of chicken with truffle purée in the center of each; served in an ornamental croustade with Allemande sauce. **CHICKEN CROQUETTES A L'ITALIENNE**—Finely cut cooked chicken with some mushrooms; thick butter-and-flour sauce made containing minced onion, salt, pepper, nutmeg, lemon juice, parsley, raw yolks; chicken mixed in, cooled; made in shapes or long rolls; breaded, fried; white Italian sauce. **CHICKEN RISsoles**—Raw chicken-meat minced with fat salt pork and herbs, long thin rolls inclosed in thin paste, edges joined with egg; fried in lard; ends trimmed off. **CROMESKIES OF CHICKEN**—Same mixture as croquettes; small finger-lengths rolled in shavings of cooked fat salt pork, dipped in batter and fried. **POTAGE A LA REINE**—A cream-of-chicken soup, the chicken pounded and passed through a seive. **PATTIES OF FOWL A LA CORDON BLEU**—Vol-au-vent patty cases, white purée of breast of chicken, and cream enough to nearly fill them; whipped white of eggs salted, colored green with parsley juice heaped in each patty; slightly baked to set; served on lace paper. **STUFFED PULLET, TURTLE FASHION**—A boned chicken made to look like a turtle; served hot. Bones taken out, head left on and half covered with the skin of the neck, like a turtle's head; body filled with forcemeat and sewed up; chicken feet skinned, inserted for fins. The chicken braised in stock, decorated in dish with truffles to imitate shell. **PULLED FOWL**—Pulled meat from cooked fowls, lightly floured and fried in butter, then stewed in stock, thick gravy with starch, and quince jelly; garnished with cress and pickled fruit. **CHICKEN CURRY**—Mr. Friday Madrassi's specialty. A large chicken cut in joints; 2 onions and 3 oz. butter fried together; chicken added, and 2 tablespoons curry powder, salt, cupful of gravy; gently stewed till tender, finished with 1 tablespoon lime juice; served with rice. **CHICKEN A LA D'ESCARS**—The Duc d'Escars was one of half a dozen nobles whom Louis XV associated with himself in a series of

## CHI

cooking sprees, when they prepared their own grand suppers, each member carrying out his own part. The king would devote himself to *poulet au basilic* and preparations of eggs, in which he was highly skilled. The Duc de Gontant would prepare the salad; the Duc de Coigni would superintend the *roti*—each one of the party being famous for certain dishes—and there were never fewer than forty-eight. D'Escars died of a cramp colic through eating a little of the king's purée of truffles; the king looked upon it as an insult and would not attend the funeral. However, the d'Escars' chicken was trussed as for boiling, the breasts larded, placed in a stewpan lined with slices of bacon, a slice of ham, onion stuck with cloves, herbs, carrot, stock and sherry; cooked over moderate fire with coals on the lid to brown the larding; sauce strained, skimmed, reduced to glaze. **POULET A LA BOIVIN**—Specialty of a French restaurant. Chicken cut up, browned in a pan with butter, button onions, potato balls (scooped out of raw potatoes); seasoned; finished by baking in the oven with blanched and quartered artichokes in sauce pan; gravy made in pan with meat glaze and tarragon; little heaps of the artichokes, potatoes, etc., around the chicken in dish, and sauce over. **BRAISED FOWLS WITH TOMATO SAUCE**—The breast bone removed without dividing the fowl, butter, salt, pepper and lemon juice put in place of it; slices of lemon on the breasts; bacon slices in the pan; braised, glazed; tomato sauce. **CUT-UP FOWL**—To avoid difficulty of carving, carved in kitchen, bound up again with narrow ribbon, easily severed by one who must carve at table. **CHICKEN FRITTERS**—Pieces of cold roast chicken soaked in seasoned vinegar; dipped in batter; fried. **INDIAN-FRIED CHICKEN**—Joints rubbed with curry powder, fried in oil; served on bed of fried onions. **ROAST FOWL**—With slices of lemon on breast; fowl wrapped up in thin slices of bacon and buttered sheet of paper; roasted an hour; giblet or tomato sauce. **CHICKEN ROLLS**—Long finger-rolls split half open, and inside hollowed out, filled with chicken forcemeat, closed; dipped in egg, fried light brown; parsley garnish. **ROAST PULLET AU JUS**—“At the Café Royal, Regent street, famed alike for its *cuisine* and its cellar, an enjoyable dish is a ‘surrey chick,’ otherwise a roast pullet or capon, served simply *au jus*, with watercress. This is the equivalent of the *poulet de Pavilly* one may enjoy at Bignon's restaurant, so dear to Parisian epicures.” **CHICKEN FILLETS**—Larded fillets, having 4 fine strips of pork for each, seasoned, breaded, fried; a spoonful of tartare sauce served on each one. **POULET A LA VIENNOISE**—Halves of chickens steeped in oil, drained, breaded, broiled; served on toast with white sauce in which whipped raw cream is stirred at the last moment. **CIGARETTES OF CHICKEN A LA REINE**—Fine-pounded chicken forcemeat, with chopped truffles, rolled to cigar-shapes; breaded and fried. **POULET A LA ALBERT VICTOR**—Cigarettes of green herbs and hard-boiled yolks-

## CHI

forcemeat rolled in shavings of tongue and ham; used to fill up a boned chicken; larded outside, breaded; white mushroom sauce. **RISSOLETTES DE VOLAILLE A LA POMPADOUR**—Fine-pounded chicken forcemeat (*quenelle*) used as a paste to inclose pieces of chicken-croquette preparation, like square sandwiches; dipped in batter and fried. **CHICKEN A LA SONTAG**—Cut up, fried slightly in butter with onions and raw ham; broth added; thickened, strained; served with shredded leeks fried, and boiled rice mixed in the sauce. **CHICKEN IN WHITE SAUCE**—Whole, trussed, stewed in stock, with dash of vinegar to keep white; dished with white sauce, flavored with celery; boiled cauliflower garnish. **CHICKENS IN BECHAMEL**—Joints of chicken cut up after boiling, and bones taken out; in cream sauce; minced parsley on top; truffles around. **SOUFFLE DE GELENOTTES A L'ESSENCE DE TRUFFES**—A Parisian specialty. Pounded breasts of 4 chickens, as for *quenelles*, mixed with little white sauce; butter, salt, pepper, nutmeg, 5 yolks and 2 whites raw, passed through a seive, grated truffles added, whipped cream and whipped whites in a buttered mould; cooked in *bain-marie*; served with sauce of wine in *veloute*. **FRIAR'S CHICKEN**—Joints of chicken stewed in seasoned broth with chopped parsley; thickened with egg yolks. **GLAZED CHICKENS**—English name for *poulets au supreme*. **POULET A LA PARMENIER**—Paris hotel specialty. Chicken in joints fried in clear butter; potatoes scooped out size of cherries cooked same way; potatoes around the chicken; parsley dust over all. **CHICKEN AND RICE**—Stewed chicken taken up, liquor strained and rice boiled in it, along with seasonings; chicken served in center. **ROAST CHICKEN A LA BRESSOISE**—The chickens of Bresse were mentioned by Savarin as of the highest excellence, owing probably to the breed of fowls. "The black LaBresse fowl, which furnishes so much of the choice poultry eaten in Paris, especially the capons and poulardes, is unequalled in quality of flesh, and quantity and weight of eggs." The fat chickens are roasted with bards of bacon on the breasts, served with cress in the dish and sauce of the chicken drippings; livers, shallot, bread crumbs and orange slices rubbed through a seive. **POULETS AUX PETITS POIS**—Chicken in joints stewed in brown gravy; green peas added, and onions and parsley. **BROWN FRICASSEE OF FOWL**—Joints fried in butter; flour stirred in till brown; broth, wine, mushrooms, parsley, salt, pepper; skimmed, boiled down. **CHICKEN PANADA**—For the sick. A purée of chicken with milk seasonings and flour—a cream of chicken like thick soup. **PUREE OF CHICKEN [SOUP] A LA BEARNAISE**—Chicken pounded, passed through a seive; boiling cream and almond milk added; pieces of breast of chicken in it; rings of fried bread served with it. **CHICKEN SOUP A LA CHIFFONADE**—Chicken in small pieces fried in butter; broth added; finely shredded vegetables to finish. **CHICKENS A L'ITALIENNE**—Chickens stuffed with the chopped livers, bacon,

## CHI

mushrooms, butter, mixed herbs and spice; covered with pork slices and buttered paper; roasted; sauce of blanched parsley, chives, and tarragon leaves minced in wine; oil, anchovies, lemon, pepper, salt, gravy and yolks to thicken. **SPATCHCOCK CHICKEN**—English name. A boned chicken trimmed, flattened and broiled; served with mushroom sauce or made gravy of stewed gizzard, etc., with butter and lemon juice. **CROUSTADES OF CHICKEN**—Cases of bread, shaped like cups, fried in lard and drained; filled with minced chicken in a rich sauce. **CHICKEN PIE A L'AMERICAINE**—Chicken cut up, backs, necks and rough pieces left out for broth; chicken stewed with seasoning, milk, parsley, butter, flour; poured in baking pan, covered with medium puff paste; egged over; baked an hour. **SMALL CHICKEN PIES A LA RESTAURATEUR**—Puff-paste flats rolled thin, size of palm of the hand; egged over, baked, split; chicken cut in dice in rich white sauce placed between sandwich fashion; sauce poured around; parsley garnish or chopped yolks. **CHICKEN PATTIES A LA REINE**—Chicken in cream sauce in puff-paste patty cases. **CHICKEN TO MAKE TENDER**—The proprietors of a sulphur springs hotel, noted for its fried chickens, having too much to do engaged a steward to assist them, and found it necessary to impart to him their secret as follows: "To make chickens tender, soft, white, juicy, plunge them the moment their necks are broken into very cold water and let them remain in it for from 12 to 24 hours; then take them out, scald and remove the feathers and draw them as usual. It is more trouble to pick them, but the flesh is incomparably better than chickens dressed the common way. **HANGING CHICKENS**—The meat is much improved by keeping a few days after killing. The fried and roasted chickens which are complained of as dry and tasteless are those cooked as soon as killed. **PACKING CHICKENS UNOPENED**—Chickens packed in barrels for transportation suffer damage in flavor whichever way may be adopted; but of two evils the least is to have the chickens not drawn before packing, for if once cut open they become sour all through in a short time in the boxes or barrels.

**CHIFFONADE**—Shredded vegetables for soups.

**CHIFFONIER**—A man who gathers broken victuals from the kitchen, sorts and re-sells them.

**CHILI**—Red pepper.

**CHILI SAUCE**—Made of 6 ripe tomatoes, 4 green peppers, 1 onion, 1 tablespoon sugar, 1 oz. salt, 1½ cups vinegar, chopped, boiled 1 hour.

**CHILI COLORADO SAUCE**—Made of the Mexican sweet red pepper pods finely minced in a vinegar pickle; can be bought in bottles; favorite sauce with oysters, cold meats, etc.

**CHINE OF PORK**—The fleshy and broad part of the back-bone, between the shoulders. It is roasted plain and served with apple sauce, and also stuffed in incisions with minced sage and onions.



## CHI

**CHINESE COOKERY**—The Chinese have established restaurants in New York and San Francisco, and have been with their methods and materials on exhibition in London. In the former places they are at their best in a business way; in London they were in the hands of a manager who had to make money by them, and they were under the supervision of a French *chef*, who drew up bills of fare purporting to be Chinese, which were half made up of French dishes. Chinese methods of cooking and restaurant keeping can therefore be seen to the best advantage where they are not on exhibition, but pursued with the view of making money in the regular course. There are at present eight of these restaurants in New York. **CHINA IN NEW YORK**—The Delmonico's is Hong Ping Lo's, where one can order a "spread" of forty courses which it takes two days to eat and which can be had for the sum of \$50, and provides enough for a party of six. Here is a meal for three at the Chinese Delmonico's and the prices. We had tea, samsu (rice brandy), two kinds of wine; a dish of chow-chow-sucy, which is a pungent and palatable conception of chicken livers and gizzards, fungi, bamboo buds, bean sprouts, water chestnuts, and all manner of savory spices stewed together—a dish of cuttlefish, one of ducks' breasts, chickens' wings, pigeons' wings, a bowl of rice, and a mooncake by way of sweets, and for this, with all the attendant dishes of sauces and condiments, one pays \$1.25. A full square meal, deliciously cooked, dainty and delicate, for about 40 cents apiece or less, because there was enough on the dishes to have fed three or four more people. This fact is becoming known, and over five hundred Americans are regular customers at the Celestial eating house. They do not want them there, either, because they are too cheap. They study matters closely and manage to get their meals for about 10 cents, while the Chinese, who are all high livers, spend their money freely. The *chef* at Hong Ping Lo's is paid \$100 a month and all his expenses, which are enormous wages for Chinatown. Like all chefs, he is superior, haughty and somewhat capricious. The cooking is done on brick furnaces and with hickory wood, and the half globes of iron set into the blazing coals cook the food with a rapidity that would startle an American cuisinier. The guest has the right to enter the kitchen and see if the cook is obeying orders, and if all the dishes desired are made from proper materials. This privilege is eagerly utilized by Mongolian bon vivants, who frequently make rows over the stove or kettle that would petrify a French chef with amazement. But few dishes are ready made. Raw materials are prepared for almost every possible order, and seldom require more than five minutes in cooking. The Chinese system of eating lends itself well to this practice. All bulky foods are served and eaten in pieces not larger than the end of the thumb. A chicken's heart, for example, is cut into four slices, the liver into eight, an onion is almost shredded,

## CHI

while a pigeon breast is chopped into dice as small as a pea. Another aid to quick cooking is high heat. The almond eyed cook uses kiln dried hickory or oak for fuel, and makes so hot a fire that water over it explodes rather than boils, and oil becomes a seething mass of liquid and vapor. A dish served under this regime is never cold; usually it is red hot. Dishes are never served "by portion." The guest estimates his appetite and orders accordingly. If not hungry he will order, for example, "five cents perfumed pork;" if possessing a good appetite, 10; if hungry, 15, and if famished, 20. The quantity ordered is measured out almost mathematically. Readers of the daily press know what strange dishes and stranger customs mark these eating houses. **MENUS OF FIFTY COURSES**—Dinners that begin with candied fruits, and close with delicate soups and crystallized flowers; delicacies from Corea, Japan, Tonquin and Manchooria; liqueurs such as no chemist ever distilled. **CHINA AT HOME**—The poorest family in China rarely sits down to a meal of less than three varieties of hot cooked food, and there are few more interesting sights than watching the preparation of the family meal. The boiler in which the staff of life in Southern China—rice—is prepared is made of the thinnest cast iron, so thin that a very slight tap is enough to fracture it, heated over an earthenware vessel, containing a few pieces of charcoal; and, directly the cooking is completed, each piece of charcoal is carefully lifted out, extinguished, and put away for future use. An enterprising European firm once thought to supersede the "gimcrack" native pot by a good substantial article of Birmingham make; but the enterprise proved a failure. **CHINESE DRIED PROVISIONS**—About 150 different dried substances were imported by them for use at the London exhibition. At the stalls in Canton dried ducks may be seen boned, flattened and so little changed by drying that it is possible to tell what kind they are. Rats are dried in like manner. There are castes and classes in China and some of these edibles are considered as belonging to the customary diet of the lower classes only. The special *forte* of the Chinese anywhere seems to be the utilization of all sorts of unpromising materials for making tasty dishes; they are great also on sweets. **PERFUMED ROAST PORK**—Is one of the dainties of the Chinese *cuisine*. The pork is roasted, and then hung in the smoke of various aromatic herbs, which gives it a delicious flavor. It is cut into small pieces that it may be readily handled with the chopsticks. **CHINA IN LONDON**—Fastidious people will be relieved to hear that neither puppy-dog nor cat figures on the bill of fare. It would appear that a Chinese dinner is largely an affair of samples. First come *hors d'œuvre*—minute shreds of salad, bits of sausage, and such like dainties. **CHINESE SOUPS**—**BIRDS-NEST CLEAR**—and Fishmau (? Fishmaw) à la Tortue (thick) served together in tiny slop basins. The former is made from the nest of a species of swallow gathered be-

## CHI

fore the birds have soiled them. They are prepared by soaking in water, thoroughly scoured to remove the dirt, and cut up into thin strips—these much resembling gelatine both in appearance and taste. They are considered a great delicacy by the Chinese and are very dear, the price being about \$60 a pound. Made evidently with good chicken stock, the Bird's nest Soup was decidedly good. The Fishmaw bore no faint resemblance to mock turtle, and it, too, was palatable enough. PEKIN SALMON BALLS—Made of dried salmon pounded with rice, fried in oil. PULMO—A fish dried. SHAOSHING HOT WINE or SAMSHU—This slightly alcoholic distillation from rice—the Chinese *vin du pays*—is somewhat sweet, is served hot from the kettle in little tea-cups, and to the uneducated palate is simply an abomination. As this beverage was sent round at two intervals of the dinner, we tried hard at the second sampling to discover something attractive about it, but altogether failed. A fellow diner, after pronouncing it to be “beastly stuff,” thought the taste for it *might* be acquired. But we fancy life is too short to acquire a taste for Shaosing Wine. SHARKS' FINS à LA PEKINOISE—is a toothsome kind of curry with rice. The fins of fishes and those of the shark in particular are largely utilized in the Chinese *cuisine*. They are smoked, pickled, or simply sun-dried, the bony portion being removed. The cartilaginous tissue is cut into thin strips, and either stewed with eggs or cooked as above. CHINESE CREPINETTES DE PORC—Tasty morsels indeed and this *entree* would do credit to any *chef*. Pork, by the way, is the Chinaman's favorite meat. CHINESE SWEETS—Amongst these, fried and candied potato chips and the nuts or seed of the Sacred Lotus “à la Helianthus,” whatever that may mean. These nuts are white and soft, not unlike filberts in flavor. BECH-DE-MER—trepang, or sea-slug (see cut page) enters largely into the composition of Chinese dishes. This uninviting-looking creature is fished from the deep sea and specially prepared for Celestial consumption. It ranges from six to fifteen inches long, is sometimes covered with spicules or prickles, and is sometimes quite smooth and with or without teats or feet. There are several varieties, and the finest realize as much as \$500 per ton in China where they are regarded as a prime delicacy. After boiling, the sea-slugs are cut open, gutted, and placed in drying sheds. Thus prepared they are in consistency and appearance not unlike indiarubber, and will keep for a great length of time. Made into tiny pies or cooked with truffles and served with Madeira sauce the sea-slug is by no means bad, and by a stretch—a long stretch—of the imagination one might suppose was eating turtle. CHINESE CHOP SOLY—a savory *ragout*, known as chop soly, is as much the national dish of China as is the *pot au feu* of France or the *olla podrida* of Spain. Its main components are pork, bacon, chicken, mushrooms, bamboo shoots, onions, and pepper. These are the characteristic ingredients; other incidental ones are

## CHO

duck, beef, perfumed turnip, salted black beans, sliced yam, peas, and string beans. No doubt a curious and wonderful compound, but one that may be palatable withal. CHOP STICKS—Before each diner is placed a pair of ivory metal-tipped chopsticks, and for those who cannot manipulate them the knives and forks of civilization. About the table, on the occasion of the inaugural luncheon, were distributed quaint and curious saucers, bowls, etc., containing melon-seed, comfits, lotus-seeds, cubes of sugar-cane, preserved ginger, cakes, etc. CHINESE PROVERBS—Ardent disciples of Epicurus are to be found in the Flowery Land as well as in the West, and that the kitchen is not undervalued as a ministrant to human happiness may be gathered from such Chinese proverbs as “Who eats well, thinks well, sleeps well, is well;” “The seat of the soul is the pit of the stomach;” “No saint with an empty stomach.”

CHINESE MUTTON—Cold mutton cut in pieces, stewed with butter, onion, chopped lettuce, green peas, seasonings. Boiled rice for border; meat in the center.

CHIP POTATOES—Potatoes shaved as thin as paper; fried dry in lard.

CHIPPED BEEF—Dried and smoked beef shaved extremely thin; CHIPPED BEEF IN CREAM—Shaved dried beef parboiled, mixed in cream sauce. FRIZZLED BEEF—Dried-beef shavings warmed in butter.

CHIIPOLATA—A garnish of Italian origin. Consisting of small round sausages, chestnuts, mushrooms, pieces of bacon, carrots and turnips in a brown gravy with sherry. Served with various meats designated *a la Chipolata*.

CHITTERLINGS—The intestines of the pig are prepared in France as follows: Having been thoroughly well cleaned, they are pickled for from 6 to 12 hours in a brine flavored with thyme, coriander and bay leaves; taken out, and the pieces of meat which adhere to them are removed, cut up fine, and, with the smaller guts also cut into strips, are introduced into a larger gut, which when filled is tied at both ends. The whole is then cooked, great care being taken to prevent the skin from bursting. They are again placed in brine for three weeks, after which they are either smoked or kept in vinegar. Chitterlings are either broiled, fried or stewed to prepare them for the table.

CHIVES—A kind of green onion-tops, slender, pipe-like and deep green; used in soups and sauces.

CHOCOLATE—Is cocoa paste free from oil, or nearly so, and pressed into cakes. Sweet chocolate is sugar and cocoa pounded together, usually flavored with vanilla, and pressed. ROYAL CREAM CHOCOLATE—A soft kind of chocolate in cans; a beverage. CHOCOLATE CAKES—Grated chocolate, 4 oz.; pistachio nuts, 4 oz.; little sugar, vanilla, clove and cinnamon powdered; moistened with whites; baked in patty pans; decorated with cream, almonds,

## CHO

preserves. CHOCOLATE PUDDING—Like pound cake, with chocolate mixed in; 1 lb. butter, 1 lb. sugar, 10 eggs, 2 oz. unsweetened chocolate, 14 oz. flour; steamed; chocolate cream for sauce. CHOCOLATE MERINGUE—A chocolate custard baked; the whites used to frost it over; eaten cold. CHOCOLATE JELLY—A substitute for jelly for layer cakes; chocolate, sugar and thick cream boiled; used cold. COURONNE AU CHOCOLAT—A crown or border mould of chocolate Bavarian, the interior filled with whipped cream, garnished with crystalized fruits. SOUFFLE AU CHOCOLAT—Chocolate, sugar, flour, cream and yolks beaten together; the whipped whites added; baked in small cases; to be served immediately. CHOCOLATE SOUFFLE PUDDING—Specialty of a hotel *chef* in Germany. Made of 4 oz. each flour and sugar, 2 oz. each butter and chocolate,  $\frac{1}{2}$  pint milk (a cup); all made into a paste over the fire; cooked; vanilla added, and 4 yolks; mixture beaten 10 minutes; whites whipped stiff added last; baked; served soon as done. CHOCOLATE TRANSPARENT ICING—Chocolate melted by heat in a little syrup and well worked together; boiling syrup added; used hot. CHOCOLATE [CANDY] CREAMS—Made of *fondant* sugar cast in starch moulds, then dipped in melted chocolate and cooled on glazed paper; glazed or varnished with an alcoholic solution of gum benzoin. CHOCOLATE WHIP—A variety of whipped cream to serve in cups, made of 1 qt. rich cream, 1 oz. unsweetened chocolate, 8 oz. sugar; scalded to boiling point; cooled; 4 whites added; whipped, and cream and froth served cold. CHOCOLATE MACAROONS—Best made of granulated sugar, 1 lb. to 4 whites, worked with a paddle as for icing; 3 oz. grated unsweetened chocolate stirred in; dropped on paper; slack baked. CHOCOLATE MERINGUES—Same as macaroons baked on wetted paper on boards; no bottom crust; two together like eggs. CHOCOLATE PIPE ICING—Chocolate melted by heat only poured into white icing; used to decorate cakes on the plain surface. CHOCOLATE A LA VOLTAIRE—This beverage was first invented by Voltaire, who constantly for his breakfast partook of half *café au lait* and half chocolate, which were served at the same time in separate vessels in a boiling state, and poured from each slowly about 18 inches in elevation from the cup, being thus rendered extremely light and digestible. BAVAROIS AU CHOCOLAT—*See cremes*. CHOCOLATE ICE CREAM—Dissolved chocolate in hot milk added to sweetened cream; frozen. WHITE CHOCOLATE ICE CREAM—Roasted cocoa beans bruised and steeped in hot milk, which is then used to flavor the cream or custard to be frozen. CHOCOLATE WITH WHIPPED CREAM—"The refreshments here, as in all Berlin cafés, are most varied, a favorite *consommation* being milk-coffee iced, with whipped cream on the top. Chocolate is served also with a thick top of whipped cream, and a basket of pastry is always placed on the table with the cup."

CHOPS—All the slices of mutton that can be cut on both sides of the spine bone from the neck to the

## CHO

hip. The first choice are the rib chops, the shortened ribs giving an advantageous shape; the loin chops are even better eating; they are cut from the saddle of mutton. ENGLISH MUTTON CHOPS—Double thickness; the meat of two with but one bone. BARNSELY CHOPS—Restaurant specialty. A sample sent to an editor who had heard of them weighing  $1\frac{1}{2}$  lbs. "It is usual to boil them 5 minutes before placing them on the grill, as, owing to their thickness, they would otherwise be black outside before being cooked in the middle. The plan is always to have some chops ready-boiled, so that they may be grilled off as ordered, and by this means they are dished as soon as an ordinary chop—by the time the tea is made, or the chip potatoes ready for serving. Although half cooked, perhaps, the day before grilling, a Barnsley chop is still fresh cooked, has more gravy in it than the ordinary mutton chop, and is more satisfying for a hungry customer."

CHOP HOUSES—English chop houses are growing in favor in New York. In this case it is not due to Anglomania, but to the solid comforts that can be enjoyed at the regulation chop houses. In a certain locality there are five of these little hostleries that do an immense business all day long, and are open most of the night. They do not serve oysters or pastry of any sort. They sell chops, Welsh rarebits, steaks, egg on toast, and ales and wines. The dishes are cooked with uncommon skill, and everything is served with the utmost neatness.

CHOUX (Fr.)—Cabbage.

CHOUX DE BRUXELLES (Fr.)—Brussels sprouts.

CHOUXFLEURS (Fr.)—Cauliflower.

CHOUX PASTE—The same paste of which the familiar Boston cream puffs are made; it is called *pâte à choux* in French, is used in a few forms about meats and in soups, and varied by having a slight addition of sugar and vanilla it forms two or three varieties of *eclairs*. (*See cream puffs*.)

CHOW-CHOW—Mixed pickles thickened with scalded mustard; can be bought cheapest by the keg for hotel use, or made cheaply where there are plenty of vegetables.

CHOWDER—Fish chowder is an ancient dish which has undergone alleged improvements. It is, originally, a sailors' stew, consisting only of fat salt pork, onions, potatoes, crackers, water, salt and pepper; stewed in a covered pot.

## AN OLD RECIPE, DATED 1834.

To make a good chowder and have it quite nice,  
Dispense with sweet marjoram parsley and spice;  
Mace, pepper and salt are now wanted alone.  
To make the stew eat well and stick to the bone,  
Some pork is sliced thin and put into the pot;  
Some say you must turn it, some say you must not;  
And when it is brown, take it out of the fat,  
And add it again when you add this and that.  
A layer of potatoes, sliced quarter inch thick,  
Should be placed in the bottom to make it eat slick;  
A layer of onions now over this place,  
Then season with pepper and salt and some mace.

## CHR

Split open your crackers and give them a soak. In eating you'll find this the cream of the joke. On top of all this, now comply with my wish, And put, in large chunks, all your pieces of fish; Then put on the pieces of pork you have fried— I mean those from which all the fat has been tried. In seasoning I pray you, don't spare the cayenne; 'Tis this makes it fit to be eaten by men. After adding these things in their reg'lar rotation, You'll have a dish fit for the best of the nation.

—*Note*—Fish-broth and milk are to be added. CONGRESS CHOWDER—“Every spring these parties of Congressmen and officials used to go down the Potomac on the old steamer Salem to the fishing grounds and enjoy freshly caught shad, opened, nailed to oaken boards, and cooked before large wood fires. On one of these occasions Mr. Webster had obtained from Boston some rock cod, crackers and salt pork, and he made a chowder. He had a large kettle, and having fried his scraps, he deposited the successive layers of fish, crackers and potatoes and onions over and over until there was no more room. Then pouring in a half gallon of milk he rubbed his hands, exclaiming: “Now for the fire. As Mrs. Macbeth said: ‘If 'tis to be done when 'tis done, then 'tis well 'twere done quickly.’” I quote from memory, but I shall never forget his joyous expression of countenance and the merry twinkle of his deep-set, burning black eyes. The chowder was a success, and so was a medicinal preparation of Santa Cruz rum, brandy, a dash of arrack, loaf sugar, lemons and strong iced tea. No one who ever drank ‘Marshfield Punch’ forgot its seductive excellence, but some found to their sorrow that it had a fearful kick.” CHOWDER SOUP—A fish soup made thinner than the real chowder, which is a thick stew, is served on fish days in many hotels. (*See clams.*)

CHRISTMAS PUDDING—Boiled plum pudding, made of 1 lb. each bread-crumbs, suet, raisins, currants, sugar; ¼ lb. each citron and almonds; 1 lemon, 1 orange, rind and juice; ¼ pint each brandy and sherry; 1 nutmeg, little salt, 8 eggs, cream enough to moisten. Mixed up a day before cooking; put in bag or mould and boiled 10 hours. Warm brandy poured over, set on fire and sent so to table with hard sauce.

CHUCK RIBS—Of beef, the coarser rib meat nearest the neck. CHUCK STEAKS—Shoulder steaks.

CHUMP—An inferior cut of beef; the cut back of the hip bone.

CHUM—A sort of gizzard found in the white-fish of the great lakes, which feeds on small shell-fish; the chums are reserved by the salters and esteemed a delicacy.

CHUTNEY—An East Indian sweet pickle; can be purchased at the fancy grocery stores. (*See Bengal, Indian.*) “And mango chutney, another and characteristically Singhalese condiment, among the ingredients of which I think are fresh-grated cocoanut and chillies carefully brayed together in a mortar. This chutney is of a rich roseate hue; and after eating it with his prawn curry, the epicure feels like the Grand Turk.”

## CIN

CIDER—The pure, unsophisticated juice of the apple, fermented and matured to a certain degree. Where the highest quality is desired, as for champagne cider, the fruit is crushed between granite rollers to avoid contact with metal at any stage, and the juice extracted in a wooden press. The cider is, of course, not fit for immediate consumption, but requires a period varying from a few months to even a year or two to mature. The difference as to appearance and flavor between the crude apple-juice in the first stages of its fermentation and the thoroughly ripened liquor, is almost marvellous. Taken from the wood, the well-matured cider, which has been stored for a period of two years or more, loses every trace of rawness and develops a full fine dry flavor, not unlike some of the best Continental light wines. To judge of a good sample of cider, it should have the bright and clear appearance of a first-class sauterne, and show no tendency, with climatic changes, to become cloudy or viscous. It approaches wine in many respects, and indeed bears favorable comparison with any cheap champagne at one-fourth its price. CIDER FOR COOKING—Good cider is the proper substitute for wine in all cases where that article is called for in culinary operations; good cider, indeed, is far better for cooking fish, soups, game, hams, and sauces, than the heavily adulterated wines which now flood the market. IMITATION CIDER—Is manufactured in enormous quantities for the purpose of a cheap drink to retail; the least objectionable of it is made from dried apples. It costs the retailers less than 1 cent a glass. (*See Burr-Oak.*)

CIGARETTES OF MEAT—French caterers' specialty. Finely minced chicken, or any other kind of meat, seasoned with aromatic salt, rolled up in paste, baked light color; long, slender.

CINNAMON AND CASSIA—The government chemists, investigating the adulterations of food, say: “These spices are the barks of several species of the genus *cinnamomum*, the true cinnamon being a native of Ceylon, where it is largely cultivated, and the cassias being derived from several other species growing in China, India and the East Indies. Cinnamon as it reaches the market is very thin, the outer and inner coats of the bark having been removed. Cassia, on the other hand, is thick, as it consists of the entire bark, and can be distinguished by its retaining its natural outer surface. Cinnamon is by far more valuable than the cassia, as there is a smaller supply and intrinsically it contains a much greater proportion of volatile oil, and that of higher and more delicate aroma. In consequence cassia is largely substituted for cinnamon, and, in fact, not a particle of ground cinnamon can be found in the market. It can be found in the whole condition in good quality only in drug stores. Cassia exists in many forms and qualities, and sells at wholesale at from 7 to 40 cents a pound. That known as Saigon is the best and that exported from Batavia the poorest. Cassia buds also hold a small

## CIS

place in the market. The detection of the substitution of cassia for cinnamon, since the barks are of trees of the same species, is more difficult than is usually the case and may prove troublesome to a novice. The presence of more woody fiber in the latter with the aid of chemical analysis serves, however, as a reliable distinction. In the samples which have come into our hands not a particle of material labeled ground cinnamon proved to be anything other than cassia. The spice millers appeared, however, to be satisfied to stop at this point and in only one case was there addition of cheap stuff to the cassia. When added there is no difficulty in detecting it as has been done here and in Canada, where peas, starch, ground shells and crackers have been found in powder labeled both cassia and cinnamon. The barks can, in most cases, and especially the cinnamon, be used nearly as well in the whole condition, and should at least be so purchased and then ground. A slight acquaintance with the appearance of the different qualities will teach one the proper selection to make."

**CISCO**—A small fish, a fresh-water herring abundant in the lakes of the northwest. The flesh is white, parts in fillets from the spine like the flesh of the brook trout, and is as free from small bones.

**CITRON** (Fr.)—Lemon.

**CITRON**—A large and coarse fruit of the lemon family, produced in warm latitudes; used only in the form of candied citron peel. This is boiled in water to extract the bitterness; then boiled in syrup and dried.

**CITRON MELON**—A small green melon of the gardens, the "apple-pie melon," used for cooking and for preserving, and is boiled in flavored syrup and dried in imitation of the West India peel.

**CITRON CAKE**—One pound butter, 1 pound sugar, twelve eggs, 1 nutmeg grated, 3 tablespoons rose-water, 1 pound flour, 1 pound citron thinly sliced. At least 20 different variations are made with citron, in the different cake mixtures; either in shreds mixed, or scattered over the surface of the icing, or laid on top of cakes before baking; mixed with other fruit for plum cakes or puddings, and in compound ice creams.

**CITRIC ACID**—One of the acids used in effervescing powders, in making lemonade without lemons; and in small quantities it is used in making acid candies and boiling sugar.

**CIVET** (Fr.)—A game stew. **CIVET OF VENISON**—Pieces cut size of an egg, lightly fried with cubes of salt pork; flour added, claret and broth; stewed; small onions and mushrooms to finish. **CIVET DE CHEVREUIL**—Same as the foregoing. **CIVET DE LIEVRE**—Stewed hare; in England called jugged hare, and after the first frying with salt pork the cooking is finished in a covered jar in the oven with port wine and broth. **CIVET DE LAPIN**—Civet

## CLA

of rabbit, or rabbit stewed with wine, mushrooms, onions; salt pork and herbs.

**CLAMS**—The late Sam Ward could probably have named a dozen different ways of cooking the delicious bivalve—for a clam is a bivalve—and would have named Château Yquem as the wine to take with clams. The most esteemed kind in New York is the "Little Neck" clam (so called from a neck of land on Long Island Sound, where they abound), a small round clam of a charming flesh color. It is served on the half-shell, raw, as the first course in dinners of the highest order. It is eaten off the half-shell at every corner along the wharves of New York. There are "soft-shell" clams, too, and there are "razor-back clams," the secrets of the cooking whereof are known unto the "Ichthyophagous Club." "Clam chowder" would tickle the palate of a London alderman, and in the proper confection thereof the great Daniel Webster excelled. "Clam bakes" are an occasion of much festivity on the New England coast; but Rhode Island has a proud pre-eminence for these feasts. The large kind called quahogs are only part eatable; that part, which looks like a string, is used mostly in soups and chowder, but is fried as well. **SOFT-SHELL CLAMS**—A large kind having a brittle crumbly shell, not soft and eatable like a soft crab's; they are good for fries and broils. **FRIED CLAMS**—The same ways as fried oysters. **STEWED CLAMS**—Same as oysters. **SCALLOPED CLAMS**—They are usually served in their shells, which are of a good shape for the purpose; scalded first, they are taken up, and a thick white sauce is made of their liquor; the clams put back in it, spoonfuls in shells breaded over the top, and browned in the oven. — *Roasted* in the shells, and *steamed*, they are treated and served as oysters. **CLAM CHOWDER**—The same thing with clams as fish chowder. **TUNNISON CLAM CHOWDER**—A seaside hotel-keeper's specialty; a chowder containing tomatoes and herbs, such as thyme, marjoram and parsley in addition to the regular ingredients. "Sam Ward" used to say: "Don't put salt pork in your clam chowder." **CONEY ISLAND CLAM CHOWDER**—Like the foregoing; a thick soup or thin stew containing tomatoes, clams, onions, potatoes, bay leaf, herbs, etc., started by frying the main ingredients together until half-cooked, then adding broth and little wine. **BOSTON CLAM CHOWDER**—A white, thick soup with potatoes, clams, etc.; no tomatoes. **BAKED CHOWDER**—Sort of sea-pie; the original pork, onions, potatoes, clams, crackers, water, or milk, and seasonings without much liquor; baked brown on top. **CANNED CHOWDER**—It is put up in cans; the plain variety of chowder, and only needs to have crackers and more liquor added, or tomato soup added. **CLAM FRITTERS**—(1)—The best are made of chopped clams mixed in egg batter, dropped in hot lard by spoonfuls; served with a cream sauce. (2)—Clams whole, parboiled, dipped in batter and fried. **CLAM CROQUETTES**—Parboiled and minced clams, with onions, mace, pepper, in a thick

## CLA

sauce over the fire; thickened with yolks; cooled; pieces rolled, breaded, fried. **CLAM SOUPS**—Same as oysters.

**CLARET SAUCE**—For puddings; made with  $\frac{1}{2}$  pint claret, 2 eggs, 2 oz. sugar, lemon rind, cinnamon; whisked over the fire till it thickens; not boiled.

**CLEAR SOUPS**—These are, or should be, meat-essences clarified and strained from all solid particles and having morsels of meat, vegetables or compounds in ornamental shapes added. They are named in detail under their French name. (*See consommés.*)

**CLOVES**—The flower buds of the clove tree, carefully picked and dried, constitute the spice known by that name. Their valuable properties are due to the volatile oil, which they contain, the best having as much as 10 per cent. The removal of this oil is so very easy that it is the commonest method of deception to do so before grinding the spice and to then dispose of it as pure. The addition of the cheaper clove stems is also practiced, as they cost but 6 cents when the buds cost 27. Pimento is sometimes substituted in part or entirely, as it has a clove-like flavor, but only 4 or 5 per cent. of volatile oil. It is worth less than one-fifth the price of cloves. Cloves should, if possible, be always purchased whole, as they deteriorate less readily in that form.

**CLOVE SYRUP**—For flavoring apple pies and punches; made of 2 oz. crushed cloves, steeped in  $1\frac{1}{2}$  pts. water 3 days; water strained off, and boiled with 1 lb. sugar.

**COBOURG PUDDING**—Hotel specialty. Made of 1 lb. sifted, white, stale bread crumbs, 1 lb. butter, 1 lb. sugar, 8 eggs; mixed up like pound cake, the crumbs instead of flour; steamed in a mould 2 hours; for sauce currant jelly, diluted with wine hot.

**COCOA**—It is certain that the Spanish discoverers Pizarro and Cortes learned its use in the Court of Montezuma, and they doubtless brought a knowledge of this nutritious nut into Europe. Cocoa (or more properly, ca-cao) plant has great wax-like leaves and resembles a small magnolia tree. Upon its trunk and large limbs there appear semi-annually a large number of wart-like protuberances, about as large as the smallest pineapple. At first they are green, but when they get red the natives pick them off, crush them in a rude machine, and take from each a handful of seeds about the size and shape of a Lima bean. This is the cocoa. When the beans are thoroughly dried in the sun, they are shipped to the market in gunny sacks, where the chocolate manufacturer gets hold of them. The first operation consists of carefully picking and sorting the beans, the next in roasting them, after which they are crushed and winnowed, which reduces them to the familiar form of cocoa nibs. After the nibs have been carefully ground through warm mills, a portion of the cocoa-butter is extracted. This is valu-

## COC

able for its medicinal qualities. When this first oily extract is removed, the grinding of the cocoa residue proceeds until it has a creamy consistency, which, when cold, assumes the familiar form of pure cocoa. This, however, is too rich in fatty matter for most stomachs, and in order to prepare the well-known cocoa extract, the cocoa is placed under enormous pressure—1,200 lbs. to the square inch. This expresses all the remaining cocoa-butter. The dry mass is then taken out, ground, reground, and sifted through sieves. This reduces the cocoa to a beautifully fine impalpable powder that constitutes the well-known "Cocoa Extract," which contains all the virtues and aroma of the original nut without its oleaginous drawbacks.

**COCOANUT**—The fruit of the cocoa-palm. Since the introduction of the desiccated cocoanut the uses have increased to an astonishing degree.

**COCOANUT PIE OR PUDDING**—Fresh grated cocoanut, butter, sugar, 4 oz. of each, 4 whites,  $\frac{1}{2}$  glass brandy, 1 teaspoon orange-water; in a pastry crust.

**COCOANUT GINGERBREAD**—Made of 1 cup molasses,  $\frac{1}{2}$  cup sugar,  $\frac{1}{4}$  cup butter,  $2\frac{1}{2}$  cups flour, 4 oz. desiccated cocoanut, 3 teaspoons powder, ginger;

baked in cake pans. **COCOANUT MACAROONS**—(1)—Desiccated cocoanut, 8 oz.; sugar, 2 oz.; 2 whites stirred together; small drops on paper; light baked.

(2)—Same way and weights as chocolate macaroons; cocoanut for chocolate. **COCOANUT TAPIOCA PUDDING**—Tapioca, 8 oz.; milk, 1 qt.; sugar, 4 oz.; eggs, 6; cocoanut, 4 oz.; baked.

**COCOANUT SPONGE CAKES**—Small sponge cakes the usual way with little less flour and cocoanut in its place. **COCOANUT SMALL-CAKES**—Three cups sugar; 1 cup each butter, milk, cocoanut; 2 eggs; 2 spoons powder; flour

to make dough to roll out; sugar on top before baking. **COCOANUT MADELEINES**—Small pound cakes dipped in diluted jam and rolled in grated cocoanut.

**COCOANUT GENOISES**—Jelly cake with jelly on top and cocoanut upon that. **COCOANUT JELLY-ROLL**—

Outside of roll wetted with diluted jelly, rolled in cocoanut mixed with sugar. **IMPERIAL COCOANUT-CAKE**—Like Savoy cake with cocoanut; made of 1 lb. each sugar and cocoanut; yolks to make stiff

paste; 9 whites, whipped firm, stirred in alternately with 8 oz. flour; baked in long tins; sugar over.

**COCOANUT ICE CREAM**—Desiccated or fresh, stirred into the custard while hot, then frozen; best is fresh, grated in pure cream; not boiled. It is mixed also

in banana ice-cream, in corn-starch pudding, in blanc mange, in orange pies, etc., etc.

**COCOANUT OIL**—Used to adulterate butter and lard. The first attempts to use it so failed on account of its strong flavor; that is now removed by injecting sprays of steam in the oil for several hours, which results in deodorizing it.

**COCOANUT SHELLS**—Used largely in the adulteration of ground pepper and other spices. The government analysts cite an instance of a New York firm having in a short time used and put upon the

## COC

market more than 5,000 lbs. of cocoanut shells in their spices.

**COCOTTE**—A cup or deep dish for cooking eggs in. **EGGS A LA COCOTTE**—Eggs in buttered *cocotte*-cups with a spoonful of cream on top, same as shirred eggs except that they are steamed instead of baked.

**COCHINEAL**—Used for coloring; is an insect which lives upon the stems of a plant in Mexico.

**COCHON (Fr.)**—Pig. **COCHON DE LAIT**—Sucking pig. **COCHON DE LAIT A LA CHIPOLATA**—Sucking pig stuffed with chestnuts and sausage, served with a Chipolata garnish. **COCHON DE LAIT EN GALANTINE**—A sucking pig boned, stuffed, braised, served hot. **PATE FROID DE COCHON DE LAIT**—A cold raised pie of the English pork-pie order, made with sucking pig.

**COCKIE-LEEKIE SOUP**—See *Scottish Cookery*.

**COCKLES**—A small sort of scallops; used as a substitute for oysters and shrimps in fish sauces; eaten raw with vinegar and plainly boiled in salt water. **COCKLE PATTIES**—Same as oysters and clams. "Cockles, which come in season this month, are excellent pickled or in patties. We are told that from Morecambe Bay alone, £20,000 worth of these delicious little shell-fish are taken every year."

**COCKSCOMBS** — Frequently mentioned and commended for use in foreign recipes, and one of the principal reliances for ornamental finishes to elaborate hot dishes; may be obtained in bottles and cans at the fancy grocery stores. They are the combs and wattles of yearling chickens, blanched peeled and stewed.

**COD**—Is in season every month in the year; is at its best in mid-winter. The head and shoulders are considered the best parts and are generally boiled; the thinner parts being sliced and fried. **CODFISH STEWED WITH ONIONS**—Slices in butter-sauce with chopped onions. **COD A L'INDIENNE**—Slices of cod baked with butter and seasonings and a curry sauce poured over, made of 2 onions, 1 carrot and 1 apple, sliced and fried in butter; flour, stock, anchovy and curry added; parsley and lemon garnish. **CURRIED COD**—Slices of cod fried with onions, gravy added, curry powder, cayenne, butter, cream, flour, salt. **CABILLAUD A LA HOLLANDAISE**—The thick part boiled, served with Hollandaise sauce. **CABILLAUD RECREPI, SAUCE AUX HUITRES**—Crimped cod, boiled, oyster sauce. **CABILLAUD FARCI AU FOUR**—Cod stuffed and baked. **CABILLAUD A LA PORTUGAISE**—Codfish steaks floured and fried; tomato sauce flavored with anchovy. **CABILLAUD GRILLE A LA COLBERT**—Steaks broiled, spread with *maitre d'hotel* butter; potato balls around. **CABILLAUD A LA CREME**—Boiled cod picked apart in flakes, in cream sauce, dredged with parsley dust, or *a la creme au gratin*, covered with bread-crumbs and browned. **CODFISH BAKED A LA NEW BEDFORD**—The fish split and laid open, marinated in oil and seasonings,

## COF

drained, buttered, bread-crumbed, baked; wine or cider and oyster liquor in the pan for sauce. **CODFISH BOILED, FLEMISH SAUCE**—Fresh cod boiled in salted water acidulated with vinegar, drained, dished up on a folded napkin surrounded with parsley leaves; sauce separate made of butter-sauce yellow with mustard and egg yolks. **COD A LA PROVENCALE**—Pieces of cold fish mingled with shallots, chives, oil, pepper, salt, lemon peel, nutmeg; baked, sprinkled with lemon juice. **CODFISH CROQUETTES**—Cold fish and oysters chopped together, bread-crumbs, cream, pepper, salt; made up in balls, breaded and fried. **DRIED COD**—When the cod is dried on the downs it is called *dun-fish*, from the Gaelic root *duin*, a hill. If dried on the rocks, it becomes *rock-cod*, or the *klipp-fish* of the Norwegians. Among these the cod is called *torsk*—in English *tusk*, from the Gothic *duerren*, to dry. The well-known Aberdeen fish, or French *laberdan*, is from the Gaelic *abar*, the mouth, and *dan*, a river—a fish caught near the river-mouth. Heraldic designs of ancient pattern bearing devices of fishes are well known, and the king of the Danes has a representation of the dried cod upon his coat-of-arms. **CORNED COD, LING or HADDOCK**—A fish split open and laid in salt for three days, then dried for two days, is excellent broiled. **MORUE AU GRATIN**—Salt cod in cream sauce, cheese, bread-crumbs and butter on top; baked. **BRANDADE DE MORUE**—Salt cod in butter-sauce, oil and garlic; finely chopped before stirring in the sauce. **CODS SOUNDS**—Are to be bought at most provision stores; they are in barrels, salted, and require 24 hours' soaking; they are then boiled in milk and water, and when tender dressed in all ways same as salt or fresh fish, broiled, spread with forcemeat; fried in batter, etc. **COD ROE**—Is parboiled in salt water with vinegar, cut in slices, dipped in batter and fried, or egged and breaded. **SMOKED COD ROE**—Breakfast relish; soaked, sliced, fried a little, served on toast. **CODFISH BALLS**—One-half boiled salt cod, one-half potatoes, egg yolk and pepper to bind and season, run through a meat grinder, balled up, rolled in flour; fried. Codfish ball preparation ready for use can be bought in cans; needs only balling and frying; will bear more potatoes added. **CODFISH FRITTERS**—Codfish ball mixture with more eggs added, little butter and chopped parsley, dropped from spoon into hot lard. **WHAT THE COD EATS**—"The dredge is considered usually by naturalists to be the best implement with which to obtain information upon deep-sea life, but Professor Baird says that the stomach of the cod is the best of all dredges, for it usually contains morsels of every sort of marine resident within reach; while only a few weeks since a theatre-programme was found in the stomach of one. With a high-born contempt for the requirements of trade, the cod feeds upon herring and mackerel extensively, being also somewhat partial to lobsters."

**COFFEE QUOTATIONS**—For menus:

## COF

"Coffee! O coffee! Faith, it is surprising,  
'Mid all the poets, good and bad and worse,  
Who've scribbled (Hock and China eulogizing)  
Post and papyrus with 'immortal verse'—  
Melodiously similitudinizing  
In Sapphics languid or Alcaics terse—  
No one, my little brown Arabian berry,  
Hath sung *thy* praises—'tis surprising, very!"

—"In 1652 the first coffee-house was opened in New-man's Court, Cornhill, London, by a Greek named Pasquet. This man was the servant of an English merchant named Edwards, who brought some coffee with him from Smyrna, and whose house, when the fact became known, was so thronged with friends and visitors to taste the new beverage that, to relieve himself from annoyance, Edwards established his servant in a coffee-house. Once tasted, coffee sprang into popular and imperishable favor, and it is curious to refer back to the opinions expressed concerning it by wits and dignitaries at different periods. "If you want to improve your understanding, drink coffee," said Sydney Smith. Sir James Mackintosh professed that he believed the difference between one man and another was produced by the quantity of coffee he drank. Pope was among confirmed coffee-drinkers, often calling up his servant in the middle of the night to prepare a cup for him. It was the custom in his day to grind and prepare it upon the table, of which practice he gives the following details in verse:

For lo! the board with cups and spoons is crowned,  
The berries crackle, and the mill turns round;  
On shining altar of Japan they raise  
The silver lamp; the fiery spirits blaze.  
From silver spouts the grateful liquors glide,  
While China's earth receives the smoking tide.  
At once they gratify their sense and taste,  
And frequent cups prolong the rich repast.  
Coffee! which makes the politician wise,  
And see through all things with his half-shut eyes.'

—"From the *Spectator* we learn who frequented the houses, and the 'Grecian,' 'Squire's,' 'Searle's' have become immortal. In Queen Anne's time, so it is said, there were three thousand coffee-houses. It was 'Will's' coffee-house, William Urwin being the proprietor, of No. 1 Bow Street, which was 'sacred to polite letters.' Pope frequented Will's, as did Steele. Tickell, Budgell, Prior, Gage and Halifax went to Button's coffee-house in Covent Garden. Then, too, 'Garroway' was headquarters for surgeons and apothecaries, as 'Child's' was the haunt of the physicians. Sir Isaac Newton was in a brown study at the Grecian. Swift sought the 'St. James,' and it was at 'Lloyd's' where the placid Addison sometimes sipped his coffee. With the coffee-houses sprang in opposition the chocolate-houses, the most celebrated of which were 'White's' and 'The Cocoa Tree.' The taverns of the time of Queen Anne were thronged. Good people cracked their bottles there and dined and supped, and bullies kicked the drawer and invented new oaths and curses. 'The Devil and the Dragon,' 'The Rummer,' 'Crown and Anchor,' 'The Mitre,' 'The Cock,' immortalized by Tennyson; 'The Boar's

## COF

Head,' 'The Three Cranes,,' drew many gallant fellows together in the first half of the last century."

"Yes, the wine's a wayward child—  
This the cup that 'draws it mild.'  
Deeply drink the stream divine;  
Fill the cup, but not with wine—  
Potent port or fiery sherry.  
For this milder cup of mine  
Crush me Yemen's fragrant berry."

—"It contains sufficient stimulating properties to restore an exhausted system without having the power to intoxicate. Even in its early days an old writer of the seventeenth century claims for the beverage this virtue when he thus quaintly descants upon its various merits: 'Surely it must needs be salutiferous, because so many sagacious and the wittiest sort of nations use it so much. But besides its exsiccant quality it tends to dry up the crudities of the stomach, as also to comfort the brain, to fortify the sight with its steeme, and it is found already that this coffee-drink has caused a greater sobriety among the nations. For whereas formerly apprentices and clerks with others used to take their morning draft in ale, beer, or wine, which by the dizziness they cause in the head make many unfit for business, they use now to play the good-fellows in this wakefull and eivill-drink.'"—"A companion once remarked to Voltaire that coffee 'was a slow poison,' when the great wit and coffee-drinker replied: 'It must be very slow, for I have been drinking it for seventy years.'" COFFEE AND THE KORAN—"Coffee advanced rapidly from the Red Sea and the Nile to Syria, and from Asia Minor to Constantinople, where the first coffee-house was opened in 1554, and soon called forth a number of rival establishments. But here also the zealots began to murmur at the mosques being neglected for the attractions of the ungodly coffee divans, and declaimed against it from the Koran, which positively says that *coal* is not of the number of things created by God for good. Accordingly the mufti ordered the coffee-houses to be closed; but his successor declaring coffee not to be *coal*, unless when over-roasted, they were allowed to re-open, and ever since the most pious mussulman drinks his coffee without any scruple of conscience." FIRST NEW YORK CAFE—"When, in 1832, the physicians in the city urged all to abstain from drinking beer and wine, and to drink *pure* coffee, in order to avoid the epidemic of colera that was then raging, a large and convenient coffee-house was opened by the famous *restaurateur* George Washington Browne on the first floor of what was known as the 'Auction Hotel,' in Water Street. The place soon became known as 'Browne's Coffee-House,' and was a most popular dining resort for merchants. On the south-east corner of what are now Pine and William Streets there stood from 1812 to 1830 the Bank Coffee-House, kept by William Niblo." HINTS TO COFFEE-DRINKERS—"Raw coffee (the unroasted berry), if kept in a dry place, improves with age. Those who wish to enjoy coffee in perfection should have it



## COF

fresh roasted. Roasted coffee should be kept in an air-tight vessel; the Viennese prefer a glass-bottle to a canister. Coffee is very absorbent, and, according to good authorities, should at no time come into contact with metal. A mill, though convenient, is not essential. The Turks do not grind their coffee, but pound it in a mortar with wooden pestles. Brillat-Savarin, the great French epicure, who tried both pounded and ground coffee, preferred the former. One ounce coffee to a pint of water makes poor coffee; an ounce and a half to a pint makes fairly good coffee; two ounces to a pint make excellent coffee. Such coffee, mixed with half, or even three parts, its bulk of boiling milk, forms an ideal breakfast-food for body-workers and brain-workers. A very small quantity without milk, taken after a full meal, stimulates the stomach to the necessary effort of digestion, and wards off the drowsiness which often follows satiety. This neat infusion is generally known as 'black' coffee. But genuine coffee, when infused, is not very black. An excessive black color is given by means of burnt sugar, and is no sure indication of strength. It is a mistake to suppose that costly and cumbersome machines are necessary for making coffee. The Brazilians insist that coffee-pots should be made of porcelain or earthenware, not metal. Excellent coffee may be made in a common jug provided with a strainer. Warm the jug, put in the coffee, pour boiling water on it, and the thing is done. Coffee must not be boiled; let it gently simmer; violent ebullition dissipates the aroma. If a quantity be wanted, good coffee can be made some hours beforehand, even overnight if necessary. For this purpose use any large earthenware vessel; heat it to receive the coffee; fill up with boiling water; protect the contents from the air by a wet cloth over the lid or other covering. When required, pour gently off the clear infusion and heat it to the simmering point. Complicated filters are unnecessary if your coffee be pure; if mixed with chicory, dandelion root, roasted acorns, roasted cabbage-stumps, or other forms of vegetable offal, which on boiling disintegrate and yield a thick, starchy, albuminous, sugary soup, you will then want an ingenious filter. There are four distinct kinds of coffee. The first and best is the Mocha, the berries of which are nearly round and of a pale yellow color. Next in quality comes the Martinique, with berries elongated and of a soft green hue. The Rio ranks next, the berries being small and nearly gray. Lastly come the Java, whose berries are large, flat and pale gray. The Mocha is particularly delicious as a flavoring in creams and ices. It must be roasted lightly and infused when quite hot; then the essence of pure coffee is obtained. Equal portions of Bourbon and Martinique make a good blend in coffee. Java is inferior. Never blend coffee until after roasting, because, their berries not being of uniform size and dryness, the cooking of them will be irregular. Do not roast over-much; when the berry is very dark—not black—and has become

## COL

moist, take it off the fire and cool it quickly. The conditions of a good supply of coffee are a well-developed roasted berry, roasted within forty-eight hours of its consumption, ground immediately before using, and brewed for public supply in clean, fresh pots every twenty or thirty minutes."—**FRENCH COFFEE**—See *cafe* and *drinks*. **TURKISH COFFEE**—"To make Turkish coffee you need a mill, which grinds the coffee to a very fine powder; when the water is boiling, add a sufficiency of lump sugar according to taste, and then, when the sugar is quite dissolved, the coffee, in the proportion of a large tablespoonful to each small cup. Stir round vigorously, and let the boiling water rise once. The coffee is then ready and should be served in a copper or brass pot. Special *verseuses* (out-pourers) for the purpose can be obtained and are very ornamental. Turkish coffee is, of course, for postprandial use." **RUSSIAN COFFEE**—"Russian coffee is still more easy to make. Fill your cup half full of coffee ground as above, and pour the boiling water on it, and sweeten to taste. When the coffee has been properly ground, the grounds, far from being unpleasant, form a delicious *cream* at the bottom of the cup, the dregs of which in this case are the best part of the draught. **COFFEE CREAM**—Bavarian cream coffee-flavored, set with gelatine; made of 1 pint custard, 1 oz. gelatine,  $\frac{1}{2}$  cup strong clear coffee, 1 pint cream whipped; set in a mould on ice. **COFFEE CUSTARDS**—Yolks-of-egg custard flavored with clear coffee; in cups; steamed, meringued when cold. **COFFEE ICE-CREAM**—Best made with pure cream with sugar and strong clear coffee; custard can be used, or part cream. **ICED COFFEE**—A popular beverage consisting of coffee with cream and sugar the ordinary way, with shaved ice added; shaken up; imbibed through a straw. **COFFEE CAKES**—Meaning cakes to eat with coffee, are kinds of sweetened bread; some are flat-bread cakes with sugar and cinnamon on the surface; others are buns or rusks. (See *Café*.)

**COINGS (Fr.)**—Quincies.

**COLBERT SAUCE**—Brown; made of 1 pint espagnole, 2 tablespoons extract of beef, pepper, parsley, lemon juice, 6 oz. butter beaten in by portions, not boiled.

**COLBERT SOUP**—Endive soup with eggs, made of shredded hearts of endive, blanched, stewed in butter, stock added, yolks and cream to thicken, a poached egg served in each plate.

**COLD STORAGE**—Since artificial ice-making has become general, some hotels employ the freezing process itself instead of ice for their cold rooms. The process consists of the rapid evaporation of ammonia by heat; the vapor passing through pipes produces intense cold; the pipes being laid in brine the latter becomes colder than ice, and being circulated through other pipes along the walls of store rooms, meat rooms, etc., the cold brine keeps them at a freezing temperature, so that meat remains

## COL

frozen in them for weeks, and *carafes* of water are frozen more or less as wanted. This system is called cold storage. It is employed on board the ocean steamships, and by its means fresh meat is kept frozen during the voyage from Australia or New Zealand. The ammonia employed in the process is condensed and used again with but little loss. In most towns now there are cold-storage accommodations for hire to those who need, yet have not business or room enough to put in their own plant.

COLLATION—Lunch.

COLLEGE PUDDING—A plum-pudding mixture made up into balls size of an egg, floured, fried and served with wine sauce. COLLEGE PUDDING BAKED—Made of 6 oz. bread-crumbs, 3 oz. sugar, 4 eggs,  $\frac{1}{2}$  cup milk, 6 oz. each suet, currants, citron, little brandy and nutmeg.

COLORINGS—RED—Cochineal, 1 oz., pounded fine in a mortar,  $\frac{1}{2}$  pt. water,  $\frac{1}{2}$  oz. salts of worm-wood; boiled 1 minute;  $\frac{3}{4}$  oz. cream tartar, little powdered alum, strained, little sugar added to keep it. CHERRY RED—Dutch grappe madder, 2 oz., tied in a cloth and beaten in a mortar, with water, 4 pts.; boiled; alum and oil of tartar added, let settle, wash the sediment, dry it, dissolve in alcohol. BEET RED—Juice of blood beets for ices and jellies, extracted by pouring boiling water acidulated, over slices. BLUE—(1)—Indigo in warm water for some uses; for candy, indigo pounded fine is dissolved in gin or alcohol. (2)—Prussian or Antwerp blue ground fine and mixed with water. YELLOW—Turmeric or saffron dissolved in water or alcohol; tincture of saffron is used for coloring ices and syrups. Barberry root with alum and cream tartar makes a yellow for candies. GREEN—(1) Fustic, 1 oz.; turmeric,  $\frac{1}{4}$  oz.; alum and cream tartar each 2 drachms, water,  $\frac{1}{2}$  pt.; boiled; tartar added first, alum later. This makes bright yellow; indigo dissolved in alcohol added to make green. (2)—Green is made by boiling spinach 1 minute, then squeezing out the juice by twisting in strong towel; parsley answers the same purpose; both may be used to make a lighter green by pounding them raw in a marble mortar and not boiling. BROWN—Burnt sugar or caramel; the sugar is burnt till it smokes and looks like tar, water added and boiled. Many shades in soups and jellies, from yellow to orange, light and dark brown, and port wine color and purple, are obtained with caramel and its admixture with cochineal. See *aniline*, also *annato*.

COLORINGS, DELETERIOUS—A Philadelphia society for the prevention of adulteration, has sent out a list of 35 poisonous colorings, with their common and also their chemical names, warning bakers and confectioners not to use them. They are mostly the colors found in the paint shops, and are mineral compounds. The principal need of a coloring seems to be for a yellow, to imitate the richness of yolk of eggs in buns and cakes, which contain no eggs. "Notwithstanding all that has been published relative to the poisonous character

## COM

of chrome yellow as a coloring matter for confectionery, buns, cakes, and pastry, President Amerling states that a large number of bakers are still using the stuff. Yesterday he visited five bakeries, each of which does a large business, and in every case chrome yellow was found in use. The proprietor of one of these, a prominent up-town baker, was exceedingly indignant at the appearance of President Amerling, and stoutly denied using the poison. 'Well, what do you use?' asked the president. 'Why, canary yellow, and that's not poison. I'm not afraid to eat it myself.' The matter, when shown, proved to be nothing else than chrome yellow. The baker was cautioned not to use it again under pain of prosecution. He had been reported to the society by a gentleman who stated in a letter that his own family and a number of neighbors had been made sick by eating buns purchased at his bakery."

COLLOPS—(1)—Minced beef; same as beef sausage meat; same as Hamburg steak, except variations in the seasonings. (2)—Beefsteaks of small size. (3)—A slice of meat of any kind is called a collop in some places; synonymous with steak.

COLUMN CUTTERS—Tubular cutters of the apple-corer shape are so called; they are put up in sets or nests, running from the size of macaroni to an inch diameter. Used for cutting cork shapes of vegetables for chartreuses, pipe shapes for consommés, cores and lozenges for potatoes to fry, to serve with fish, etc., and for stamping out round slices of beets for decorating salads, egg custards for soups, and the like.

COMMUTATION TICKETS—At restaurants; reduced rate tickets.

COMPOTES—Fruits stewed in syrup so as to keep the original shape, not broken. COMPOTE OF PEARS—Pears pared, but not divided, simmered in porcelain kettle with water to cover; dipped out, syrup made of 1 lb. sugar to about 8 pears, little cinnamon, glass of sherry added to the pear liquor, boiled down, pears in it; served cold. COMPOTE DE ABRICOTS—Apricots stewed in syrup. COMPOTE DE PRUNES REINE-CLAUDE—Greengage plums boiled in syrup. COMPOTE DE PECHES A LA CONDE—Peaches boiled in syrup and served on a bed of rice, sweetened, red currant jelly diluted poured over. The best qualities of California canned fruits in syrup are fine compotes ready made. COMPOTE DE FRUITS A LA NORMANDE—Pear butter; made by stewing pears in cider or perry. COMPOTE D'ORANGES—Quarters of oranges boiled in syrup; served hot with a berder or cassollette of rice flour, or cold with cake. COMPOTE DE MARRONS—Chestnuts boiled in syrup with lemon juice; served on oval pieces of fried bread dipped in diluted jelly. COMPOTE OF PEACHES A LA CONDE—Peaches in halves in syrup; rice made like pudding, part cooked as peach-shaped croquettes, remainder a bed to build the peaches upon; ornamented with candied fruits and syrup over the peaches and around the

## COM

croquette border. **POMMES A LA PARISIENNE**—A compote of apples in quarters, stewed with butter in the syrup; served on toasted rusks (*brioche*), red currant jelly in the syrup poured over all. **ICED COMPOTE OF STRAWBERRIES**—Fresh berries made ice-cold on ice; syrup and sauterne wine mixed and frozen and spread over the berries.

**COMPOTIERE**—Crockery-ware fruit stand; a tall bowl.

**COMUS**—The god of revelry; sometimes named in connection with feasting. The luxuries of the table are called the gifts of Comus.

**COMFITS**—That class of candies like sugared almonds, having a center covered by successive coats of sugar. Comfits mentioned in recipes to strew over cakes are extremely small, like seeds of various colors.

**CONGER EEL**—A very large species, as much larger than the common eel as a fowl is larger than a partridge. A prejudice against eating it exists in some localities, as is the case with our catfish, but not everywhere. **CONGER FOR BREAKFAST**—The bone taken out without dividing the fish; salt and pepper rubbed in, the meat side laid open; the fish then fastened on a wall in the shade to cure for two days; pieces cut off, broiled and buttered. **CONGER EEL STEWED**—In brown gravy, or dressed in steaks or cutlets, is by no means contemptible eating; it is also good roasted, or baked, made into a soup, or curried. **CONGER SOUP**—The head and shoulders of a large conger is covered with cold water, sweet herbs, onion, piece of lemon peel; boiled 1½ hours; skimmed free from the oil of the fish; milk, flour and butter thickening, and green peas added, and the fish in pieces. “The conger eel good eating as soup? Well, I should just think so. You ask the first Guernsey man you come across—Guernsey man or Guernsey woman, Jersey man or Jersey woman (as Mrs. Langtry, for instance)—what is the pride and glory of his or her island. ‘Why, conger-eel soup,’ will be the answer. And so it is. The first time I tasted it was at a ‘toncy’ dinner at the Governor of Guernsey’s house. In fact, it is the national dish of Sarnia. The Elizabeth College boys are notoriously so fond of it that they go by the name of ‘College Congers,’ the cause of an eternal feud and much bloodshed between them and the ‘cads,’ or town boys. The soup is made principally with milk, but you have the proper recipe.”

**CONGRESS CAKE**—Paris specialty. Made of 12 oz. sugar, 8 oz. butter, 9 oz. flour and starch (about half and half), 6 yolks; butter, yolks and half the sugar creamed together; rest of sugar added, and flour and flavorings; baked in a border mould, center filled with jelly; served warm.

**CONSOMMES**—Clear soups. Made by preparing a soup as to strength and flavorings complete, but generally without any thickening ingredients; straining it, adding chopped lean raw meat and white of eggs, and boiling, then straining it clear

## CON

and transparent through a jelly bag or cloth. **CONSOMME A L’IMPERATRICE**—Clear soup with a poached egg in the plate; named for the Empress Josephine. **CONSOMME AUX ŒUFS POCHES**—Another name for the foregoing. “The story runs that the Empress Josephine returned after one of the imperial hunts at Fontainebleau very tired and had just time to change her dress for dinner. ‘The only thing I could eat at dinner,’ she exclaimed, ‘would be a new-laid egg.’ One of the ladies hearing this hurried to General R., who was the superintendent of the palace, and transmitted her mistress’s wish to him. The general immediately communicated with the *chef*, who saw no better way of gratifying the Empress’s wish than by introducing poached eggs into the clear soup. All the menus were written ‘*Potage Consomme*’—the only addition to make was ‘*a l’Imperatrice.*’ The guests wondered, but the Empress was pleased, and the new soup had its days.” **CONSOMME A LA COLBERT**—Clear soup with shreds of lettuce, celery, Jerusalem artichokes and small onions. **CONSOMME A LA PRINCE DE GALLES**—Clear soup with small diamond shapes of quenelle forcemeat inclosing pieces of chicken meat, *royale* custards in same shapes, and asparagus points. **CONSOMME AUX HARICOTS VERTS**—Clear soup with shreds of string beans cooked green and kept separate till served. **CONSOMME AUX PATES D’ITALIE**—Clear soup with any of the various Italian pastes, but preferably with the alphabet or similar fancy pastes. **CONSOMME A LA JERUSALEM**—Clear soup with balls like large peas scooped out of Jerusalem artichokes. **CONSOMME A LA MONTE CARLO**—French specialty. With fancy cutters vegetables and truffles are cut out to imitate clubs, diamonds, spades and hearts; chicken forcemeat dotted with truffles make dominoes; pipe macaroni stuffed with purée of green peas and forcemeat, cut across, forms rings. These are all served in the plates of clear soup. **CONSOMME NATIONAL**—French specialty. Vegetables reduced to a savory mince inclosed in small egg shapes of chicken forcemeat; served in a plate of clear soup; the vegetables used are 2 carrots, 2 leeks, 1 turnip, cut in dice and fried in butter, then stewed in consommé to glaze. **CONSOMME A LA DUCHESSE**—A clear soup slightly thickened with starch, which becomes clear again by slow simmering; then strips of white meat added. **CONSOMME A LA NIVERNAISE**—Clear soup with fancy Italian pastes, quenelles and vegetables stamped in shapes. **CONSOMME AU VERMICELLI**—Clear soup with vermicelli, the latter cooked and kept separate till served. **CONSOMME AU TAPIOCA**—Clear soup with tapioca previously washed and steeped in cold water, drained and simmered in the consommé until transparent. **CONSOMME A LA ROYALE**—Clear light-brown soup containing squares of egg custard; this is made by mixing a very little broth with some eggs as if for an omelet, 5 yolks and 1 whole egg preferable to all eggs, then cooking it in a buttered pan set in another pan of boiling water. If subjected to

## CON

too much heat and rapid boiling, the custard becomes spongy and cannot be cut to shape. When done, the custard is turned out and cut diamond-wise and a few pieces served in each plate. The changes are to make some all yolk, some all white, and some white colored with beet juice, some green colored with spinach juice or parsley. CONSOMME DESCLIGNAC—Clear soup containing sherry and with *royale* custards stamped out in round lozenge shapes with shapes of carrot and turnip to match. CONSOMME A L'ANDALOUSE—Clear soup with vegetables cut in thin rounds with a column cutter; also a tomato omelet mixture of 1 pint tomato sauce mixed with 12 yolks and 2 whole eggs steamed, and a piece of it in each soup plate. The tomato mixture to be either steamed in thimble moulds or cut in diamonds out of large pan. CONSOMME A LA MACEDOINE DE LEGUMES—Clear soup with all sorts of different-colored vegetables cut into very small dice. CONSOMME A LA BOURDALOUE—Clear chicken broth served with squares of white chicken meat and French peas in the plates; also in each one a thimble mould of rice, seasoned and bound with yolks and colored like lobster; steamed. CONSOMME DE GIBIER—Clear, dark and strong essence of game soup, with small cubes of breast of grouse and balls of rabbit forcemeat made green with parsley and poached separately. CONSOMME A LA MONTMORENCY—Clear chicken broth with chicken-forcemeat balls and squares of lasagnes paste in the plates, and also cigarettes of forcemeat rolled up in blanched lettuces; braised. CONSOMME SAGOU LIE—Clear soup with washed sago simmered in it; about 2 oz. to a gallon. CONSOMME AUX POINTES D'ASPERGES ET ŒUFS POUCHÉS—Clear soup with a poached egg and spoonful of green-cooked asparagus heads in each plate. CONSOMME A LA MAGENTA—Clear soup colored slightly with red tomato juice, an assortment of vegetables cut as for macedoine; chopped celery-leaves, chervil and parsley. CONSOMME A LA MEDICIS—A white soup slightly thickened with flour and butter; a poached egg in each plate; also, a fried *croustade* filled with purée of chicken (like a patty) served separately. CONSOMME A LA RACHEL—A cream-colored soup thickened with flour and butter, yolks and cream; little custards of chicken forcemeat prepared as for *royale*, green peas and small cut string beans in the plates. CONSOMME A LA KURSEL—Clear soup with spring vegetables, peas, asparagus-heads and shred lettuce. CONSOMME PRINTANIERE—Spring soup; clear with early summer vegetables, especially peas and asparagus-heads. CONSOMME PRINTANIERE ROYALE—Printaniere with *royale* custards in it besides the vegetables. CONSOMME A LA CHATELAINNE—Clear soup with *royale* custards, made of  $\frac{1}{2}$  pint purée of white onions in 10 yolks and 2 eggs and spoonful of cream and seasonings; also, peas and cut string beans. CONSOMME A LA PALESTINE—Chicken broth with stewed Jerusalem artichokes in slices; also some rice cooked separately in distinct grains and mixed in. CONSOMME

## CON

A LA NAPOLITAINE—Clear, strong game broth, with stewed celery in small squares, game forcemeat quenelles, macaroni in inch lengths, and shapes of fried bread. CONSOMME AUX PETITS NAVETS A BRUN—Clear soup with brown-fried cubes of turnip. CONSOMME AUX QUENELLES—Clear soup with small balls of chicken meat finely pounded, mixed with cream, yolks, finely minced parsley, seasonings, poached separately. CONSOMME AUX PROFITEROLES—Clear soup with light balls of *choux* paste in the plates. (*See choux*). These are boiled in broth with the steam shut in if to be served immediately, for they rise and then fall; but, if not, are baked in a very slack oven till dry, when they remain light. The paste for these has a proportion of grated cheese mixed in. CONSOMME A LA XAVIER—Pron. Hevier. Clear soup with shred lettuce or cabbage and other vegetables, and pea-shaped drops of paste made by dripping egg-batter through a colander into it while boiling. CONSOMME JULIENNE—Clear brandy-colored soup with vari-colored vegetables, which are cut into shreds, like straws, and half cooked in butter and sugar before being added to it. Brillat-Savarin says that he taught a New York restaurant-keeper named Julien how to change his ordinary *pot-au-feu* into this artistic soup, and that it had a great run as Julien's soup. CONSOMME A LA BRUNOISE—Clear brown soup with vari-colored vegetables cut in very small squares, and green peas. CONSOMME A LA PAYSANNE—Peasant's soup. Clear broth with various vegetables cut small, and shred lettuce. CONSOMME A LA JARDINIÈRE—Gardener's soup, perhaps flowery soup. Clear soup with vari-colored vegetables stamped in small fancy shapes. There are jardinière cutters to be bought which perform this operation speedily enough. CONSOMME A LA CHIFFONADE—Clear soup, like paysanne, with shred lettuce and peas. CONSOMME A LA SEVIGNE—Clear chicken broth having *royale* custards consisting of pounded chicken meat and eggs, and green peas and small cut green string beans in the plates. CONSOMME A LA TALMA—Clear soup with *royale* custards made of almond purée, or milk mixed with eggs, and boiled rice in the plates. CONSOMME AUX TROIS RACINES—Clear soup with cubes of carrots, turnips and celery. CONSOMME AU MACARONI—Clear brown soup with macaroni boiled separately, cut in rings and added to the consommé when served—not to dull its clearness by being stirred about in it. CONSOMME AUX CROUTES—Clear soup with small thin triangles of bread, fried in butter, in the plates. CONSOMME A LA CAREME—Clear soup, brandy-color, containing small round lozenge-shapes of vegetables, lettuce, sorrel, chervil leaves, asparagus points, little sugar with the seasonings, and small shapes of bread toasted in the oven. CONSOMME AU RIZ—Clear soup with a little rice in large distinct grains, washed after cooking, then put in the soup. CONSOMME AUX PETITS POIS—Clear soup with very green peas—June peas or French. (*See potages and soups.*)

## COO

**COON**—The racoon; American small wild animal; weight, 10 to 20 lbs.; is considered good game, but generally only plainly baked or stewed—country fashion.

**COQ DE BRUYERE** (Fr.)—Black-game; a species of grouse.

**COQUILLES** (Fr.)—Shells. **COQUILLE DE HOMARD**—Scalloped lobster served in the shell. **COQUILLES DE MOULES**—Mussels scalloped in scallop-shells. **COQUILLES DE HOMARD A LA CREME**—French specialty. The meat of a lobster cut in dice with the third of its volume of mushrooms; Bechamél sauce with the mushroom liquor, fish essence, cayenne; the lobster and mushrooms mixed in the sauce, put in scallop shells, bread crumbs on top, and butter to moisten; baked. **COQUILLES OF SALMON A L'ITALIENNE**—Small slices of salmon with sauce, baked in silver scallop-shells, bread crumbs on top—scalloped salmon steaks.

**CORBEILLE** (Fr.)—Basket. **CORBEILLES DE FRUITS**—Baskets of fruit. **CORBEILLES D'AMANDES PRALINEES**—Baskets built of sugared almonds.

**CORDIAL**—An alcoholic syrup of any flavor; a *liqueur* is flavored spirit without syrup.

**CORDON BLEU**—A cook of the first order; generally, however, applied to first-class female cooks. The name has reference to the order of the blue ribbon instituted by one of the French kings. "King Louis XV had among his numerous failings a supreme contempt for female cooks and never would admit that they could cook a dinner worthy of being eaten by him, until one day, when he was dining with the celebrated Madame du Barry and was served successively with dishes of the most *recherche* description admirably cooked, he was so overcome at such elaborate and perfect fare that he asked to see the cook, but on hearing that all this was the handicraft of a woman he felt quite disgusted; however, soon recovering his serenity he consented, and, at the request of his mistress, he enobled the cook by conferring upon her the 'Cordon Bleu,' (the order of knighthood of the Saint Esprit, instituted by Henry III), which from that time has been the recognized definition of a skillful female cook. In France, when you are dining with friends and admire the fare, it is quite the correct thing to say to the mistress of the house: 'Madame, you have a veritable cordon bleu!'"

**CORKAGE**—A charge made for opening bottles of wine, service, use of glasses, etc., additional to the price of the wine.

**CORN**—In the United States it is Indian corn or maize; in England corn means all grains that are used for making bread; wheat, oats, barley and rye are all corn over there, and Indian corn is maize. **GREEN CORN**—Gathered when in the milk state it is more succulent than even the tenderest green peas; it is never so thoroughly a luxury as when eaten off the cob, as is the custom; the ears should

## COR

be prepared by having one row of grains cut away, it is then boiled about 20 minutes in salted water; served in the folds of a napkin, eaten with butter. **CUT-OFF CORN**—The tender ears cooked and the grains cut off and seasoned with salt and butter, served in dishes same as peas. **GREEN CORN PUDDING**—Cut-off corn mixed with butter, milk, salt, pepper, and yolks enough to make it a soft custard when baked; eaten as a vegetable. **GRATED CORN PUDDING**—The green ears grated raw and the pulp made up with cream, eggs and butter into a custard-like preparation; either baked or cooked in a farina kettle. **GREEN CORN FRITTERS**—Cut-off corn mixed with flour, egg and butter, dropped by spoonfuls into hot lard, fried brown. **CORN MOCK OYSTERS**—Raw corn shaved off the cob, or grated, mixed with salt, pepper, eggs, little flour; fried on both sides like eggs, singly; breakfast dish. **CORN MEAL**—Ground corn, not corn flour; it makes lighter and more palatable bread when ground coarse. **CORN BREAD**—A plain kind is generally used as a dinner bread; made of only meal, water and salt, made up soft, baked in spoonful lumps on a baking pan. **CORN HOE CAKE**—Corn bannocks, like Scotch barley bannocks, baked thin on a girdle. **CORN LIGHT BREAD**—Two-thirds meal,  $\frac{1}{3}$  wheat flour, little sugar and shortening, powder and milk, or buttermilk and soda; baked in a pan. **CORN EGG BREAD**—Rich like unsweetened cake, with scalded meal, salt, lard, eggs, milk, little sugar, powder; baked in pan or mould. **CORN BATTER CAKES**—Same mixture as foregoing made thinner, poured by spoonfuls on a hot griddle; varied by mixing a proportion of wheat flour with the corn meal. **CORN-AND-RYE BREAD**—Mixture of the two kinds of meal with salt, molasses, and powder or yeast. **CORN MEAL MUSH**—Porridge of meal boiled in water. **CORN MEAL GRUEL**—Mush made thin. **FRIED MUSH**—Porridge allowed to get cold, cut in blocks, dipped in egg and cracker dust, fried in hot lard; breakfast dish. Is also rolled in flour and sauté in a little butter. **CORN HOMINY**—White; corn denuded of the bran and broken to the size of peas. Used as a dinner vegetable after long cooking. **FINE HOMINY**—A grade of the size of grains of wheat, boiled; used either for breakfast, dinner or supper. **HOMINY GRITS**—A grade fine as granulated sugar, most frequently used for breakfast and supper in the form of porridge; eaten with milk or cream. **HULLED CORN**—Home-made hominy, grains soaked in lye until the bran is nearly dissolved, then washed and boiled; used boiled for lunch and supper, and fried with butter for breakfast. **CORN MEAL PUDDINGS**—(1)—Baked; made of 8 oz. meal boiled in 1 qt. water or milk, molasses, butter, eggs, ginger. (2)—Boiled; made of 8 oz. meal, 1 quart water, suet, sugar, lemon, eggs. **CORN SOUP**—A cream of corn; the grains finely shaved and scraped off the cob, added to veal or chicken stock with a piece of lean pickled pork and few vegetables, milk or cream, butter and flour at

## COR

the finish. **CORN AND TOMATO SOUP**—Vegetable soup with chopped tomatoes and grains of corn. **CANNED CORN**—Some brands are put up in such perfection that the canned is as good as the green and can be used in its place; when stewed it has a little milk added to it, and perhaps a trifle of starch or flour thickening. **POP CORN**—A diminutive sort of maize, the grains of which burst open when roasted. **POP CORN BALLS**—A popular cheap sweetmeat made by mixing syrup with popped corn while hot, and making it up in balls wrapped in transparent paper. An immense business is done in this product in the large cities. **CANDIED POP CORN**—Of various colors; made by stirring the popped corn in a copper kettle over the fire, and pouring syrup, allowing it to dry upon the grains.

**CORNE D'ABONDANCE** (Fr.)—Horn of plenty; the cornucopia.

**CORNICHONS** (Fr.)—Pickled cucumbers or gherkins.

**CORN STARCH**—Obtained by steeping crushed maize in water and pressing it through straining material into troughs of water. Starch will not dissolve in cold water, but settles at the bottom. **CORN STARCH CUSTARDS**—Starch used the same as arrow-root; 2 oz. starch in a quart of milk thickens it to the consistency of cream; eggs are added according to the requirements. **CORN STARCH PUDDINGS**—(1)—Baked; made of 4 oz. starch, 1 qt. milk, scalded together; sugar, butter, eggs, flavoring. (2)—Boiled; 4 oz. starch, 1 qt. milk, sugar, butter, 2 yolks, flavoring. Starch is not to be cooked much, but taken from the fire soon as thick; it turns thin with much boiling or baking. **CORN STARCH BLANC MANGE**—Boiled pudding with less starch set in moulds; turned out cold; served with cream or fruit jelly. **CORN STARCH JELLY**—Acidulated lemon syrup thickened with starch, simmered clear, set in moulds; can be made with raspberry or any red juice. **CORN STARCH CREAM FRITTERS**—The boiled pudding with yolks added, flavored, made cold, cut in shapes, breaded and fried; served with maraschino sauce. **CORN STARCH MERINGUE**—The baked pudding with fruit jelly on surface; meringued; baked. **CORN STARCH CAKES**—Have a proportion of starch instead of some of the flour. **CORN STARCH ICE CREAM**—White, useful for combinations of colors and to make without eggs; made by thickening boiling milk with starch, butter to whiten it, sugar, lemon; frozen as usual. **CORN STARCH THICKENING**—Soups, gravies, sweet-pudding sauces, etc., thickened with starch and allowed to simmer from 15 to 30 minutes, become clear and transparent as before, smooth and bright, as they would not be with flour.

**CORNED BEEF**—Beef that is pickled in a salt-peter brine which makes it of a pink color distinct from plain salted beef.

**CORNED FISH**—Salted fish; not smoked.

**CORNUCOPIA**—The horn of plenty; classical

## COT

emblem of abundance; much used by cooks and confectioners in decorative work.

**COSEY**—English; a thick cap of woolen material to drop over the tea pot to keep it hot while the tea is drawing; is sometimes highly ornamented with needle-work.

**COSTER OR CUSTARD APPLE**—Fruit of the West Indies.

**COTTON-SEED OIL**—This must be counted now among the important food products of the United States; it is produced in immense and constantly increasing quantities. The government commissioners report: "Refined cotton-seed oil is usually very free from acid, and when properly prepared is of pleasant taste and admirably adapted for edible and culinary purposes, for which it is now extensively employed, both with and without its nature being acknowledged. It is now substituted for olive oil in some of the liniments of the United States Pharmacopœia, but its principal applications are in soap-making and the manufacture of factitious butter." As far as the buyers of provisions are concerned, the objection to cotton-seed oil is that it is sold in disguise; as oil by its proper name it can be bought at prices from 50 cents to 90 cents or \$1.00 per gallon, dependent upon the degree of refining it has undergone and the size of packages; but if bought with "pure olive oil" label upon the package it may cost \$3.00 per gallon or more. A test for cotton-seed oil to distinguish it has formerly been to subject it to cold, when it would set in the bottle too thick to run; that test is no longer good, however, for the stearine is now pressed out at a low temperature, and the oil remains limpid. It has been easy to detect it by the smell in frying, but that only holds good with common, half-refined oil; the best has no unpleasant smell, and is now generally used in restaurants and hotels for frying, instead of lard. One of the greatest manufacturers of lard testified not long ago that about one-third of the lard made was cotton-seed oil; which fact accounts for the establishment of three grades of lard in regular business, the lowest being always semi-fluid at medium temperature and useless for making the best pastry, while the next grade above bears evidence of having been chemically treated in its soapy, pasty tenacity. If it must be purchased for economical reasons, instead of buying it in the guise of lard or olive oil, it is wise to buy cotton-seed oil for what it is at the lowest price, taking care to obtain a thoroughly refined article. That it needs and is highly susceptible of refinement this interesting extract from the government chemist's report will show: "The oil as expressed from the seeds contains in solution, often to the extent of 1 per cent., a peculiar coloring matter, which is characteristic of this oil and its seed, and which gives the oil a ruby-red color, sometimes so intense as to cause the oil to appear nearly black. The coloring matter causes crude cotton-seed oil to

## COT

produce stains, and hence is removed by a process of refining. This is usually effected by agitating the crude oil at the ordinary temperature with 10 to 15 per cent. of solution of caustic soda of 1.060 specific gravity, when the alkali combines with the coloring matter and saponifies a portion of the oil. The mixture becomes filled with black flocks which deposit on standing and leave the oil but slightly colored. Refined cotton-seed oil is of a straw or golden-yellow color, or, occasionally, nearly colorless."

**COTELETTES (Fr.)**—Cutlets. These meaning originally mutton or lamb chops having the rib bone in them, the end of the bone trimmed serving as a handle, all the unusual things denominated cutlets or côtelettes are imitations of the cutlet shape with little regard to their composition. **CÔTELETTES DE HUITRES**—(1)—Large, flattened, fried oysters in bread crumbs, with a stick of macaroni inserted to represent the chop bone, and perhaps a paper frill upon it. (2)—Oysters cut small, mixed with bread crumbs, sauce, yolks, etc., made out into cutlet shapes; breaded and fried. (*See chicken cutlets, etc.*)

**COTE DE BŒUF (Fr.)**—Ribs of beef.

**COULIBIAC**—A national Russian dish of eggs and cabbage baked like a pie; made of 2 cabbages, 2 large onions chopped and fried, salt, pepper, 4 oz. butter; all stewed till tender; when cold, 6 chopped hard eggs mixed in; made like a thin fruit pie, with bottom and top crust of puff paste; cabbage filling; egged over; baked.

**COURONNE (Fr.)**—Crown. Fillets or small pieces of meat are dished *en couronne* when piled in ring form. **COURONNE DE BRIOCHE**—A ring-shaped plait or twist, or loaf of brioche.

**COUGLOF (Fr.); KAUGLAUFF (Ger.)**—A class of yeast-raised cakes, of which "election cake" is the American example.

**COURT-BOUILLON**—A highly seasoned liquor to cook fish in; consisting of: (1)—Water, white wine, salt, pepper, onion, cloves, bay leaf, thyme, parsley and a carrot. (2)—In creole cookery it is a brown sauce containing tomatoes, oil and garlic.

**COUVERT (Fr.)**—Cover; the table setting; the plate with folded napkin, knife, fork, etc. **DINER DE 40 COUVERTS**—Dinner of 40 plates, or persons.

**COVENTRIES**—Coventry puffs or tarts, made like "Banburys." Turnovers of triangular shape with raspberry jam inside; sugar glaze baked on top.

**COW-HEELS**—Often mentioned in foreign recipes; they are calves' feet of a larger growth, and can be used the same ways; are used to make gelatinous soups; soured in vinegar; stewed with odds and ends of raw meat to make brawn or head cheese.

**CRAB**—There are several varieties of edible or marketable crabs, besides a good many that are merely natural curiosities. The smallest is the *Oyster Crab*, found living in the same shell with

## CRA

the oyster, and of late this has come into the list of delicacies; oyster crabs in various styles are served at the restaurants—mostly, however, in the form of a bisque soup. There is another variety so like it in size and appearance as to lead to the inference that when oyster crabs are scarce, as they must generally be, the other one may be made to do duty for it. This is the *Fiddler Crab*—one of the most singular of living creatures; it is only a size larger than the oyster crab, but instead of passing its life in water and in darkness it loves the sunshine; it lives in moist burrows in the sand near salt water, and comes out in countless thousands, making strange motions at the mouth of its burrow when there are no intruders in its precincts; it has one large claw, nearly as big as its body, which it either folds across its front like a shield, or extends and makes the fiddling motion with, the other claw being diminutive, no larger than one of its legs. These are caught and used for bait. The *Deep-Sea Crab* grows as large and has as heavy claws as the largest lobsters; some are nearly covered with thorny projections. These large specimens are the kind to serve as dressed crabs in their own shells. The *Common Small Green Crab* seems to exist in all parts of the world; it is found in the markets by the wagon load, and is the staple kind for all the ordinary well-known dishes of crab. **STUFFED CRABS**—Crabs boiled five minutes in salted water, the flap and inside part called "the dead meat" and "the lady," but which is the gills and generally sandy is thrown away; crabs pulled open, back shells saved whole, all the meat collected and chopped fine; thick sauce made by simmering chopped onion in butter, adding flour, then milk, salt, white and red pepper, yolks, minced parsley, lemon juice, and the crab-meat; shells filled with the mixture; bread crumbs on top; baked. **BUTTERED CRAB**—A large crab boiled, the meat picked out, mixed with salt, pepper, nutmeg, cream or melted butter, and bread crumbs; shell filled; crumbs on top; baked; served hot with toast. **CRABS A L'AMERICAINE**—The meat picked out from 4 dozen crabs, drained, 2 raw yolks added, salt, cayenne, little chopped parsley, 2 tablespoons bread crumbs; made into balls or croquettes; breaded and fried. **HOT CRAB**—The meat of a large crab, rich gravy, or cream, and curry paste, seasoning and fine bread crumbs; the shell filled; crumbs on top; baked. **CRAB SAUSAGES**—"Would you like to eat crab sausages? Boil some of these animals; reduce them to a pulp; mix with this some spikenard, garum, pepper and eggs; give to this the ordinary shape of sausages, place them on a stove or gridiron, and you will, by these means, obtain a delicate and tempting dish. Apicius assures us of this fact; and he was a *connoisseur!*" **CRAB PIE A LA GUERNSEY**—The meat of a large boiled crab chopped, seasoned with salt, white pepper, little nutmeg, pinch of cayenne, lump of butter handful of bread crumbs; moistened with 2 or 3 spoons vinegar, hot, mixed with little made mustard and salad oil; shell filled; bread.

## CRA

crumbs on top; baked; served very hot. **BROWNED CRAB**—A large crab, the shell buttered inside, the meat minced and mixed with partly fried onion, parsley, mushrooms, truffles and butter; flour, salt, cayenne, few spoonfuls of broth or gravy; filled into the shell; bread crumbs on top; baked. **CRAB SOUP**—Crabs boiled, cleaned, broken, fried with onion and bacon; meat from other crabs held in reserve; water and tomatoes added to the fried crabs; stewed, thickened with flour and butter; cream added, salt, pepper, picked crab meat. **COQUILLE DE CRABE**—Scalloped crab or devilled crab in the shell. **SOFT-SHELL CRABS**—In season only 4 months, May, June, July, August; the crab casts its shell yearly, and this is the new shell unhardened. **SOFT CRABS FRIED**—The small legs removed, also the flap and gills inside it; washed, wiped dry, dipped in cream, fried quickly in a kettle of hot lard or oil; dredged with fine salt; served on a napkin with parsley and lemon. **SOFT CRABS BROILED**—Breaded, flat in a double broiler, done over hot coals, and basted with butter. **SOFT CRAB A L'INDIENNE**—Cut in pieces, partly fried in butter with onions, curry powder, broth, etc.; served with rice. **CRABS A LA CREOLE**—"The Creole style of cooking hard-shell crabs is highly approved by epicures, but it doesn't recommend itself to Mr. Bergh's society for the prevention of cruelty. A big iron-pot is put over a very hot fire. The bottom of the pot is then covered with, say, 3 pints of the best white-wine vinegar, into which a few pinches of salt are thrown; upon this is sprinkled red pepper; then 2 or 3 narrow sticks are placed above the liquid, the ends resting at the sides of the pot; the cover is put conveniently by for hurried action; then the alive-crabs are packed in to the full, and the cover is put on. The steam of the condiments soon enwraps them, and when the carapax is cardinal red, 'a dish fit for the gods' is ready for the refrigerator and then for the table. It is said by those who have eaten crabs cooked in this peculiar way that the natural moisture and flavor of the meat are preserved, and that the boiled condiments give singular piquancy to it." **DRESSED CRAB**—Is crab salad; the meat mixed with oil, salt, pepper, vinegar and mustard; served in the large crab's shell on a bed of cress or lettuce. **CRAB WITH TOMATOES**—"Baked tomatoes, partly stuffed with crab-meat, is a new delicacy, and a sandwich made of one slice of a large, ripe, juicy tomato with a layer of crab-meat, cooked creole style, isn't so bad." **DEVILLED CRAB**—The same as the various forms of hot crab, buttered crab, etc., which are but differences in seasonings; devilled crab is made hotter, with some pungent table sauce. **CRAB SALAD**—Crab meat with chopped celery and salad seasonings. **CRAB GUMBO**—Crabs cut in pieces partially fried with butter, shallots and ham; broth added, little white wine, aromatics, green pepper, a tablespoon gumbo powder to each pint of soup; dredged in carefully; served with boiled rice. **BISQUE OF CRABS**—Crabs in pieces; with vegetables fried in butter; broth and wine

## CRA

added; then pounded shells and all with boiled rice, and passed through a sieve; soup thickened with this purée; sherry to finish; served with fried bread. **CANNED CRABS**—Crab meat ready-prepared can be bought in cans; it can be used for all the hot dishes where picked crab-meat is called for, and for soups and salads. "In England crabs are in season all the year round, but are best in the warm months. All crabs over 4½ inches across the broadest part of the shell, crabs in roe, and soft-shell crabs, are illegal."

**CRAB APPLE**—Wild apples, valued for making crab apple jelly and crab cider.

**CRACKER MEAL**—Crackers crushed and sifted; used to bread cutlets, oysters and the like for frying. It is important that the crackers used for the purpose should be of the kinds that contain no butter, as the dust of butter crackers soon turns rancid and spoils the fries. Pieces of bread thoroughly dried and crushed form the substitute for crackers, though the product is not so satisfactory.

**CRACKNELS**—Name of a kind of crackers or biscuits.

**CRACKLINGS**—The remains of pork fat after the lard is tried out. **CRACKLING BREAD**—Corn bread made of cracklings mixed in corn meal with water and salt, baked in deep skillet.

**CRANE**—Cranes were in the olden time considered an aristocratic dish. At a banquet during the reign of Edward IV two hundred and four were served. Cranes are eaten freely in the United States. A sand-hill crane appeared for many succeeding years as one of the dishes at the famous game dinners by Mr. John B. Drake in Chicago.

**CRANBERRY**—First used in Siberia and exported from Russia. Grows wild in the northern states and is improved by cultivation. The cranberry-growing interest is a large and important one, cranberry sauce having become a national institution. The cultivated berries may be known by their larger size and clean condition, for cultivators find it most expedient to have them picked by hand. **CRANBERRY SAUCE**—Stewed cranberries with sugar, stirred up, not strained; served with roast turkey, chicken, goose, pork and venison. **CRANBERRY JELLY**—Very easily made as cranberries have more vegetable gelatine than any other fruit. The syrup from cranberries stewed with sugar poured off clear, sets in jelly when cold; used in place of currant jelly with meats and in pastry. **CRANBERRY PIE**—Open tart, the fruit well sweetened. **CRANBERRY ROLL**—One of the best of "rolly-poly" puddings. (*See apple roll.*)

**CRAPAUDINE** (*a la*)—Trussed or spread out like a frog. Pigeons or chickens *a la crapaudine* are split open, flattened and broiled.

**CRAWFISH**—"I wonder when the modern caterer and book-writer, as well as the fishmonger, who ought to know better, will cease to stumble between the Seylla and Charybdis of eray and eraw



## CRA

fish. The former is a *small* crustacean found in the mouths of rivers, and the other, as a rule, larger than a lobster and a sea and harbor fish. The meat of both is rich in *inosite*, animal sugar, which easily distinguishes it from that of the lobster. Again, the crawfish is sweeter than the crayfish. The identical crawfish for this dinner were *sold* as *crayfish*; and I remember in 1880 having to review a cook book, from the pen of an illustrious writer, where the two were confounded, and the man posed as a naturalist, too." LANGOUSTE A LA BROCHE—Roast crawfish; the fish marinated in vinegar and oil, or brushed over with vinegar several times, then with butter and roasted in a very hot oven with frequent basting. When the shell becomes soft it is done; white sauce with wine, lemon juice, mace, etc. CRAWFISH CUTLETS—The head removed and all the hard parts of the tail except the terminal piece. Slit so as to be laid open, beaten flat, seasoned, breaded, fried; served with tomato sauce or fried parsley.

CRAYFISH—There are two or more kinds; the river or fresh-water crayfish, which may be found in any shallow creek or brook where cresses grow; it is used for fish bait, but never thought of as an article of diet in this country. The other is the salt-water crayfish, black with red claws while alive; it is to all intents a small lobster, the same in shape and formation, and turns red when cooked. This crayfish or crawfish is but three or four inches long. It is well understood and appreciated by the French inhabitants of Louisiana and an article of regular supply in their markets. And it is an interesting crustacean on account of its prominence in the whole system of French cookery. Truffles and crayfish tails—crayfish tails and truffles—the twain are almost as certain as pepper and salt to be met with in every dish with a name in any foreign *menu*. BUISSON DE ECREVISSES—Pyramid of crayfish; plain boiled in salted water with onions, parsley, pepper, white wine or cider, cooked for 10 minutes; served cold, built up on a napkin folded around an inverted champagne glass to form a cone; decorated with parsley. ECREVISSES A LA BORDELAISE—The crayfish well washed and alive; a stewpan is set over the fire and these preparatory ingredients are fried in it: 3 sliced onions, as many mushrooms, 4 oz. lean ham cut in dice, 2 cloves, garlic, parsley, thyme, bay leaf, salt, white and cayenne pepper. When all these are fried light brown half a bottle of chablis or claret is added and a wine glass of vinegar; when boiling, the crayfish are thrown in, covered with a lid and boiled 12 minutes, frequently stirred up. Liquor is then strained off from them, thickened with flour and butter; tomato sauce added to it, poured over the crayfish in a deep dish, fried shapes of bread around. CRAWFISH FOR GARNISHING—"Ecrevisses of the smaller kind are also extensively used in the French *cuisine* for garnishing. The 'poulet à la Marengo,' the 'tête de veau en tortue,' the 'saumon à la Chambord,' the 'matelotte

## CRE

d'anguilles, the 'pâté chaud à la financière,' would be ignoble and inartistic plates without the embellishment of crayfish. In France and in Germany, where they are abundant, crayfish is considered a very dainty article of food, and in a *dejeuner* of any importance, or an elaborate supper, a *Buisson d'ecrevisses* always occupies a prominent place on the table. In Paris the craze for them is such that they are hawked, ready cooked, about the streets, the price varying from a penny to six-pence each. The best crayfish are caught in the rivers Meuse and Rhine. Crayfish butter and crayfish tails are also well spoken of; but the most historic use to which the little river lobsters have been put, is that of making the famous potage known as 'bisque.' Bisque is as old a soup as 'potage à la reine.'" BISQUE OF CRAYFISH—Crayfish have always to be prepared for cooking by removing the intestine which would make them bitter; it is done by picking the extreme end of the center fin and with a sudden jerk withdrawing the gist containing the gall. The bisque is a purée of crayfish and rice. Made same as bisque of crabs (which see), finished with butter, Madeira, red pepper, and the tails of the crayfish reserved for the purpose. (See *Bisque*.)

CREAM—A new process has been invented recently for separating cream from milk mechanically; the appliance is called "Laval's separator." This contrivance has quite revolutionized the ordinary round of operations in the dairy. Instead of allowing the milk to stand in large shallow pans for several hours, so as to permit the cream to separate and rise to the top in virtue of gravity, the separator takes advantage of the so-called centrifugal force, and, by rapidly whirling the milk round at the rate of over 5,000 revolutions a minute, the cream collects at the centre, whilst the skim-milk passes to the circumference, and each can be readily drawn off immediately and continuously. CLOTTED CREAM—A Devonshire specialty, but a common enough product of New England dairies. The pans of milk are heated before they are put away for the cream to rise and let stand for two days. The cream so gathered is elotted; it is considered a luxury to eat with fruit and hot cakes. "An attractive looking temperance kiosk for the sale of dairy products and light refreshments. The six-penny plates of preserved apricots and clotted cream obtainable here are liberal as to quantity, and present a really delicious combination."

CREAMER—A contrivance of deep cans with a faucet in the bottom of each, placed in a framed box constructed to hold water and ice around them. The cans are filled with milk, the cream rising to the top, the skim-milk being drawn off at the bottom without disturbing the upper surface. Useful for hotels.

CREAMERY—A factory where butter is made in a wholesale way from the milk of hundreds of cows at once.

## CRE

**CREAM CHEESE**—The easiest cheese to make, and one which is much appreciated with salad; the best time for it is when the grass is rich in early summer. A pan of milk is allowed to stand 36 hours, the cream taken off, salted a little, poured into a napkin set in a dish; the cloth absorbs the watery part of the cream. When it has stood 24 hours the cream is moulded into cheese shape; ready to eat in 4 or 5 days; will not keep over a week or two. **CREAM CHEESE FRITTERS**—Sweet or savory. Cream cheese (about ½ lb.) rubbed through a sieve, 3 tablespoons bread-crumbs, 1 egg, 1 tablespoon sugar, orange flavor, made in balls, floured, fried; wine sauce. The same is done without sugar, with savory seasonings.

**CREAM CURD**—Milk curdled with rennet, mixed with cream, drained in a cloth. Used for making real cheese cakes, mixed with sugar, butter, eggs, bread-crumbs, flavorings; baked in a crust. **CREAM CURD PUDDING**—The curd mixed with currants, citron, pounded crackers, sugar, eggs flavorings; baked.

**CREAM FRITTERS**—Oblong or diamond-shaped pieces of rich corn starch pudding mixture, or of custard stiffened with flour, rolled in flour, dipped in egg and cracker dust, fried; sugared or served with wine sauce.

**CREAM TARTS**—*Darioles, mirlitons or fanchonettes.*

**CREAM PUFFS**—*Choux* paste; made of 1 pint water, 8 oz. lard or butter, 9 oz. flour, 10 eggs. First three ingredients made into cooked paste over the fire, eggs beaten in; dropped on pans; baked. The cakes rise and become quite hollow. They are cut in the side and filled with whipped cream or custard.

**CREAM SAUCE**—Made by stirring flour and butter together over the fire until it begins to bubble, then adding milk, with constant stirring; finishing with salt and lumps of butter beaten in, and cream.

**CREAM BECHAMEL**—Various qualities of cream sauce are made by using seasoned chicken broth and mushroom liquor instead of milk, but finishing with cream. Cream cannot be boiled with rich gelatinous broth without curdling.

**CREMES (Fr.)**—Creams. Bavarian creams. A class of gelatinized cream compounds; a more elaborate sort of blanc-mange, whipped while setting on ice to make it spongy and delicate. **CREME A LA BAVAROISE**—Whipped cream with gelatine dissolved in syrup mixed in; about ½ oz. gelatine to 1 qt. **BAVAROISE AU GINGEMBRE**—Ginger cream. Preserved ginger pounded, mixed with syrup and gelatine, mixed with whipped cream; set in moulds on ice; served with cake. **CREME BAVAROISE A LA PRASLIN**—Almond nougat-candy pounded and dissolved with boiling milk, gelatine and whipped cream added; moulded on ice. **CREME AU CHOCOLAT**—Chocolate cream; some chocolate dissolved in hot milk, mixed with whipped cream, sugar and

## CRE

vanilla. **PETITS POTS DE CREME**—These creams of any kind set in individual cups instead of a large mould. **CREME AU CAFE**—Bavarois flavored with coffee. **CREME DE THE**—Bavarois flavored with tea. **CREME A LA HOLLANDAISE**—Bavarois made yellow with yolks, wine added, or, a yellow custard with gelatine and whipped cream flavored with wine. **CREME AUX ABRICOTS**—Apricot pulp, sugar and gelatine added to whipped cream. **CREME A LA VANILLE**—Bavarian flavored with vanilla. **CREME DE ORANGES**—Bavarois made with orange-syrup, gelatine and whipped cream. **CREME DE FRAISES**—Strawberry Bavarian. **CREME DE PONCHIE**—Bavarois (or Bavarian cream) flavored with punch. **CREME DE FRAMBOISES**—Raspberry Bavarian; raspberry pulp and syrup with gelatine in whipped cream. **CREME AUX MILLE FRUITS**—Bavarian cream, with a mixture of various candied fruits. **CREME A LA CELESTINE**—A mould lined with strawberries and filled with Bavarian of any color or flavor. **CREME BRULEE**—Bavarois made of yellow custard flavored with caramel, sugar and cinnamon. **CREME A L'ARLEQUIN**—Bavarois with cubes of different colors of clear wine jelly stirred into when on the point of setting. **CREME A L'ITALIENNE**—Bavarois with a mixture of sultana raisins, candied peel, dried cherries; cinnamon and curaçao for flavoring. **CREME BAVAROIS AUX FRUITS**—Bavarian cream served with a compote of fruit. **CURACAO CREAM**—Yolk of egg custard, well flavored with curaçao, dissolved gelatine mixed in and whipped cream added; set on ice. **STRAWBERRY CREAM**—Berries with sugar passed through a sieve; gelatine dissolved in syrup, all mixed with whipped cream; set on ice. An ounce of gelatine to a quart is not too much when fruit is added; for whipped cream alone ½ oz. to a quart, before whipped, is enough, as too much makes the cream tough. **DECORATED CREAM**—Yellow custard with gelatine and whipped cream flavored with vanilla. Some of the gelatine custard colored pink on a plate on ice; leaf shapes stamped out of it when set, and the mould decorated with a pattern in pink leaves; filled up, set on ice. **PISTACHIE CREAM**—Made of 1 oz. gelatine, 4 oz. sugar, ¼ pt. water, hot, to dissolve the gelatine, 1 gill sherry, 1 gill kirsch added; 4 oz. pistachio nuts blanched and chopped fine, green coloring, 1 pt. thick cream, whipped, all mixed, stirred on ice till thick enough to hold up the nuts, then put in mould. It is a light green cream; can be put into a mould imitating a bunch of asparagus. **CREME FOUETTEE**—Whipped cream. **CREME FOUETTEE AUX FRAISES**—Whipped cream with strawberries.

**CREME FRITE (Fr.)**—Fried cream; cream fritters. **CREME FRITE AU CHOCOLAT**—Chocolate corn-starch custard, breaded and fried.

**CREME RENVERSEE AU CARAMEL**—Custard upside down with caramel; made by lining a mould, or small individual moulds, with melted sugar (caramel), either by melting it by heat in the

## CRE

mould or pouring in from a kettle, letting it run and set in candy on the sides, then filling up with a strong custard and steaming till just set. The candy casing partly dissolves while the custard is steaming, and serves as sauce when turned out of the mould. Served as pudding.

CREOLE—Name applied to the people born in the colonies of France and Spain of parents who were subjects of those countries. They were denied equal rights with citizens born in the old countries, although belonging to the same government. "The elements which Spain contributed to the establishment of the Mexican nationality were the oppressive exactions laid upon the people of the colony, the foolish refusal to recognize as equals the American-born children of Spanish subjects (thence called Creoles), and the ambition of her officials. Indian hate and the Creole sense of injustice of Spanish rule, were the real impulses that secured Mexican independence."

CREOLE COOKERY—It is simply the cooking of their ancestors' country. If a banquet for Creoles had to be prepared with Creole dishes; it would be sufficient, if they were of French descent, to furnish all such dishes as are denominated *a la Provençale*. The cookery of old French Louisiana is the same as the cookery of the south of France. A few specialties have taken root, such as gumbo, courtbouillon, jambalaya, pilau rissotto, bouillabaisse, and the like, but not half of them are new dishes.

CREPE (Fr.)—Pancake. "But if the pancake is an honored institution with us, it is much more so on the Continent. There, across the 'silver streak,' but more especially in the Latin countries, the *crepe* is adored for itself and as a symbol. It is the crowning, the full essence, of the joyous, rackety carnival week. The happy and harmless saturnalia culminates in a grand *Mardi Gras* and universal pancake tossing. Children, both big and small, as the day draws to a close, give way to their pent-up feelings in song:

'Mardi Gras ne t'en vas pas,  
Nous ferons des crêpes,  
Nous ferons des crêpes!  
Mardi Gras ne t'en vas pas,  
Nous ferons des crêpes,  
Et tu en auras!'

They do so, too. Why, every house in France, let the *menagere* be never so stingy on other occasions, always has ready a good supply of batter, eggs, lard or butter, to say nothing of sugar and lemons. And then, as the night steals gently on, what a to-do there is! frying everywhere; housewives and willing aids tossing the brown curling morsels with wondrous energy and happy knack, to the tune of a veritable hurricane of merry laughter. In Southern Germany the calm ladies also toss pancakes for their stolid housefolk and invited guests. As for the Italian pancake, it is not what it ought to be. It is too thick and heavy, and liberally supplied with eggs, deficient in crispness, and is generally fried in oil. The Provençal pancake is light and good, but

## CRO

flavored with orange-flower water, and fried in a very little thoroughly boiling oil. On some parts of the Ligurian coast finely-minced *beta* (a green, leafy vegetable, somewhat resembling spinach) is mixed in the batter. In Spain, ripe-pickled olives (purple-brown and full of oil) are sliced and mixed with the paste; they are fried in olive-oil. Both these are eaten as sweet dishes, in spite of the, to us, unusual ingredients." (See *Pancakes*.)

CREPINETTES—Small, thin pancakes made into turnovers with shredded bacon and truffles and some highly seasoned chicken forcemeat inclosed in the fold; brushed over with egg; baked; served with gravy, also flat sausages.

CRESSON (Fr.)—Cress. Poultry snipe, or any dish *au cresson*, is roasted and served with raw cress in the dish, and the gravy in a sauce boat separate.

CRESS—Water-cress or garden-cress; both are used the same way, either as an accompaniment and relish with roast fowl; eaten alone with salt, or combined in a salad.

CRESCENTS—(1)—Rolls of the Vienna-bread variety in crescent shape made up with milk; handsomely glazed. (2)—Shapes of Genoese cake, with water icing of various colors; cut out from sheets. (3)—Glazed crescents are also a kind of French bonbons, called *cavissants*.

CREVETTES (Fr.)—Shrimps.

CREVETTES-BOUQUETS—"A correspondence was going on some time ago in the pages of the *World*, between Theoc, the Parisian correspondent of that journal, and another, as to the French for 'prawn.' Theoc stated, and rightly, that the French for prawn is *bouquet*. *Bouquet*, according to Littré, is the diminutive of *bouc*—a goat, from the appearance of this shell fish. It is usual, however, in French restaurant bills of fare to prefix the word *crevettes*, thus: *Crevettes-Bouquet*, though, to be grammatically correct, it should be written *Crevettes-Bouquets*. It is from Brittany that red shrimps (in contradistinction to gray shrimps) are chiefly procured. In Paris these fetch a high price, about double that paid for the dull-colored variety, than which they are much less flavored. Shrimps here are called *chevrettes*, or 'little goats.' The word *chevrettes* is derived from *chevrettes*, just as *bouquets*, or prawns, is derived from *bouc-ettes*, or 'little rams.' Shrimps and prawns alike are boiled in large quantities daily, and sent up to Paris in time for the morning's markets, by the special fish, or *maree*, train."

CROMESQUIS—Kromeskies. Russian name for a sort of rissole. CROMESQUIS DE HUITRES—Oysters rolled in very thin shavings of bacon; dipped in batter; fried in hot lard. (See *Kromeskies*.)

CROQUENBOUCHE—"The name given to all large set pieces for suppers or dinners, such as nougats, cakes, pyramids of candied orange quarters, etc., which have been covered with sugar, and

## CRO

boiled to a snap, so as to give a brilliant appearance. The real meaning of *croquenbouche* is 'crackle in the mouth.'"

**CROQUETTES**—The word signifies something crisp. Croquettes are balls or any shape of almost any eatable thing, floured or bread-crumbed and fried in plenty of hot fat, then drained on paper. **CHICKEN CROQUETTES A L'ITALIENNE**—Meat of 1 large chicken cut in very small squares, half as much mushrooms; little chopped shallot; butter and flour fried together; broth added to make thick sauce; yolks of eggs, chicken and mushrooms stirred into the sauce; made cold; rolled into pear shapes, or rolls; breaded; fried; served with Italian sauce. **CROQUETTES OF BEEF PALATES**—Beef palates par-boiled and skinned; cooked 3 hours, and pressed; cut in small dice; made same as chicken croquettes; tomato sauce. **CROQUETTES DE HOMARD**—Lobster croquettes; the meat, coral, white sauce, yolks of eggs, and butter, made into smooth long rolls; breaded; fried; served with any fish sauce, which then gives the name, as with Hollandaise sauce. **CROQUETTES DE CERVELLES**—Brains scrambled with bread crumbs, milk, flour, yolks, little minced shallot, nutmeg, lemon juice, pepper, salt, parsley; made in cone or pear shapes; breaded; fried. **CROQUETTES DE VOLAILLE AUX TRUFFES**—Chicken with truffles mixed in, instead of mushrooms, and served with truffle sauce. **CROQUETTES DE VOLAILLE A L'ECARLATE**—With red tongue in the composition and in the sauce. **CROQUETTES DE POMMES**—Apple marmalade stiffened with corn starch; cooled; cut in oblongs; breaded; fried; served with sweet sauce or jelly. **CROQUETTES DE RIZ**—Rice boiled dry, slightly sweetened; butter and yolks added; made in pear shapes; floured; breaded; fried; currant jelly for sauce. **CROQUETTES DE RIZ DE VEAU**—Calves' sweetbreads; same way as chicken or brains. **CROQUETTES OF RICE AND HAM**—A London caterer's specialty. Potted ham or tongue made in small balls; rice cooked and seasoned; yolks and whipped whites added; the ham balls covered with the rice paste; egged; rolled in ground pop-corn; fried; white sauce containing lemon juice. **TURKEY CROQUETTES**—Made of 1 lb. cold turkey, ½ lb. bread crumbs, ½ lb. butter, 1 teaspoon onion, 4 eggs, parsley, little nutmeg, salt, cayenne, sweet cream; bread wetted with cream, butter and eggs; stirred over the fire, chopped meat added; cooled; balled up; fried. **CROQUETTES DE MACARONI**—Macaroni and cheese in croquette form.

**CROQUANTE**—Something made of brittle candy; a shape made of almond nougat, a case formed of a brittle cake, made of equal parts of pounded nuts, sugar and flour; to be filled with crystalized fruit, etc.

**CROSNES DU JAPON**—*Stachys*; a Japanese vegetable of the Jerusalem artichoke order, now grown in France.

**CROUTES (Fr.)**—Crusts; fried shapes of bread. **CROUTES AUX ANCHOIS**—Small pieces of fried bread

## CRY

spread with anchovy butter and filleted anchovy on top. **CROUTES AU JAMBON**—Fried bread spread with potted ham. **CROUTES AUX ANANAS**—Shapes of fried bread with compote of pineapple. **CROUTES AUX FRAISES A LA BELLERIVE**—French strawberry shortcake; strawberries on hot buttered rusks.—**CROUTES AUX ABRICOTS**—Ornamentally shaped slices of bread fried in clear butter with compote or preserved apricots; the apricot syrup colored with currant jelly poured over.

**CROUSTADE**—The same thing made of bread and fried as a casserole or cassolette, which are made of rice or potato; a case, large or small, and more or less ornamentally carved.

**CROUTONS OR CRUTONS**—*Croutes* in small, thin, fancy shapes, such as heart or leaf shapes, used to place around and decorate an entree; cubes of bread toasted in the oven, or fried, to serve with soup, especially with soups made of beans, peas, or lentils.

**CROUTE-AU-POT**—Name of a vegetable soup finished with triangular thin pieces of brown toasted bread.

**CRULLERS**—Fried cakes; doughnuts.

**CRULLS**—Of potatoes; curls, spirals, or long strings to fry. There are special tools made for cutting these.

**CRUMPETS**—English name for a yeast-raised kind of batter cake, not rich, but light; sold by bakers who make it their business.

**CRUST SOUP**—*Croute-au-Pot*. (See soups.)

**CRYSTALLIZED FRUITS**—"The process is quite simple. The theory is to extract the juice from the fruit and replace it with sugar-syrup, which, upon hardening, preserves the fruit from decay and, at the same time, retains the natural shape of the fruit. All kinds of fruit are capable of being preserved under this process. The exact degree of ripeness is of great importance, which is at that stage when fruit is best for canning. Peaches, pears, etc., are pared and cut in halves as for canning; plums, cherries, etc., are pitted. The fruit having thus been carefully prepared, is then put in a basket or a bucket, with a perforated bottom, and immersed in boiling water. The object of this is to dilute and extract the juice of the fruit. The length of the time the fruit is immersed is the most important part of the process. If left too long, it is overcooked and becomes soft; if not immersed long enough, the juice is not sufficiently extracted, which prevents a perfect absorption of the sugar. The next step is the syrup, which is made of white sugar and water. The softer the fruit, the heavier the syrup required. Ordinarily about 70 degrees Balling's saccharometer is the proper weight for the syrup. The fruit is then placed in earthen pans, and covered with the syrup, where it is left to remain about a week. The sugar enters the fruit and displaces what juice remained after the scalding process. The fruit now requires

## CUC

careful watching, as fermentation will soon take place; and when this has reached a certain stage, the fruit and syrup is heated to a boiling degree, which checks the fermentation. This heating process should be repeated as often as necessary for about six weeks. The fruit is then taken out of the syrup and washed in clean water, and is then ready to be either glazed or crystallized, as the operator may wish. If glazed, the fruit is dipped in thick sugar-syrup, and left to harden quickly in open air. If it is to be crystallized, dip in the same kind of syrup, but is made to cool and harden slowly, thus causing the sugar, which covers the fruit, to crystallize. The fruit is now ready for boxing and shipping. Fruit thus prepared will keep in any climate and stand transportation." FOR DESSERT—"Crystallized fruits make a very acceptable dish for dessert; they ornament the table and please the palate. They should be arranged with due regard to color, the darker hues, such as greengages, being used for the base, and the brighter ones, such as apricots and oranges, for the upper part, the chinks and crevices being filled with cherries and raspberries." CRYSTALLIZED VIOLETS—For 1½ lbs. fresh violet blossoms 2½ lbs. sugar; dissolved over the fire with small cup water, and boiled. The violets are par-boiled in water, drained out, then put into this syrup and boiled 10 minutes; then drained on a seive. Little more syrup made of 1 lb. loaf sugar with ¼ cup water, violets put in, and stirred till syrup granulates; then taken up and dried. Rose-leaves same way.

CUCUMBER—Though generally eaten raw as a salad it is good to cook in various ways. FRIED CUCUMBERS—Cut in slices, wiped dry, floured, fried in hot fat, salted, peppered. CUCUMBER AND EGGS—The cucumber in slices, floured, simmered in stock with parsley and lumps of sugar 15 minutes; 2 yolks added, sugar, vinegar and Worcestershire sauce, the yolks only to thicken the sauce. FRICASSEED CUCUMBERS—Same as the foregoing. BOILED CUCUMBERS—Sliced, boiled in salted water till tender, taken up, served in gravy on *croutes*. STUFFED CUCUMBERS—Seeds removed after peeling, stuffed with forcemeat of bread, suet, herbs and raw egg, boiled in milk till tender, then breaded and fried, either whole or to garnish a dish, cut across in slices. CUCUMBER PUREE—served with various dishes of chicken, veal, lamb, fish, etc., made by first parboiling cucumbers in pieces, then simmering with butter, adding salt, pepper, sugar, flour and milk to make sauce of it, passing all through a seive. CUCUMBERS A LA BECHAMEL—Pared, quartered, boiled in salted water, drained, covered with cream sauce containing little sugar. CONCOMBRES A LA CREME—Slices in cream sauce. CONCOMBRES A LA MOELLE—Stuffed with bread and marrow; brown sauce. CONCOMBRES A LA POULETTE—In cream colored sauce. CONCOMBRES FARCIES A LA CREME—Stuffed cucumbers in cream sauce containing sugar. CONCOMBRES FARCIES A L'ESPAGNOLE

## CUM

—Stuffed in short lengths, the center core being removed with a cutter, stewed in brown sauce. CUCUMBER SOUPS—Purée of cucumbers is white, made chiefly of milk and mashed cucumber. GARBURE WITH CUCUMBERS—Stewed cucumbers on crusts baked in soup to dryness, served with broth. CONSOMME A LA BEAUVILLIERS—Has stuffed pieces of cucumber and crusts in the plates. CUCUMBERS IN STEWS—Cucumber may be added to any soup or stew, and is especially good in a rich haricot. Cut in thin slices and add at the last moment; boil up for a few seconds only, and the dish may then be served. If the cucumber is cooked for any length of time, it will melt away. This may be allowed in the case of a haricot, as the flavor will be there if the slices are no longer visible. A few thin slices boiled up in a light soup make an elegant variation, and will always gratify the guests as a change. CUCUMBER PICKLES—Young cucumbers are thrown into brine as gathered, taken out and freshened at any time, scalded two or three times in boiling vinegar, but not cooked to softness. Pepper and spice in the vinegar. SALT CUCUMBER SALAD—Taken out of the brine, cut up and freshened in cold water, chopped, mixed with chopped celery, eaten with oil, vinegar and pepper. CUCUMBERS TO KEEP—Packed down in salt and water as they are gathered they keep for months; packed in layers with brown sugar between they change to pickles without further attention. Must be pressed under the liquor with a weight on top.

CUISSES (Fr.)—Legs. CUISSES DE VOLAILLE A LA JARDINIERE—Legs of fowl boned, stuffed, braised, served with mixed vegetables in sauce. CUISSES DE VOLAILLE A LA BAYONNAISE—Boned, fried with onions in oil, sauce added, bread crumbs over, browned in the oven. CUISSES DE VOLAILLE FARCIES AUX PETITS LEGUMES—Boned, stuffed, braised, on a rice border with fancy shapes of vegetables in a brown sauce. CUISSES DE VOLAILLE A L'ECAILLERE — Boned and stuffed with chopped oysters and crumbs, served with oyster sauce. CUISSES D'OIE A LA LYONNAISE—Legs of goose previously roasted, cut up, fried with onion, served with piquante sauce. SALMIS DE CUISSES DE CANETONS—Legs of roast duck stewed in gravy with wine.

CUISINE (Fr.)—Kitchen; cookery. FAIRE LA CUISINE—to do the cooking. CUISINIER—Man cook. CUISINIERE—Woman cook.

CULINARIAN—A professor of the culinary art; an expert in the literature and practice of cookery in all its branches.

CULLIS OR COULIS—Broth of meat or fish unseasoned, for use in the preparation of dishes for the table. Blond bouillon or stock.

CUMBERLAND STEW—American hotel specialty, made of 7 squirrels, 2 capons, 2 lbs. butter, 12 cans each corn and tomatoes, 2 cans lima beans, 4 loaves bread, salt, red pepper, 1 onion, 1 pint wine.

## CUL

Squirrels and fowls cut up and half cooked in butter, water and wine, vegetables added, bread crumbed in; stewed constantly till sufficiently tender.

**CULOTTE DE BEEF A LA FLAMANDE**—Round of beef with Brussels sprouts and other vegetables glazed.

**CURACAO**—A cordial; syrup with orange and clove flavors, and alcohol, used in flavoring creams, jellies, sauces, and in mixed bar drinks and punches.

**CURRY POWDER**—A yellow powder, of which the principal ingredient is turmeric, a species of ginger; used as a high seasoning for stews and all dishes *a l'Indienne*. It can be purchased everywhere, ready-prepared in bottles, or the same thing in the form of paste. It is made of slightly varying ingredients; this is a sample of what the curry-flavorings are, when put together as wanted by the native cooks of India: "**ANGLO-INDIAN FOWL-CURRY**—Materials required: (1) A small fully grown chicken of about one pound and a half in weight; (2) two ounces of clarified cooking-butter, lard, or olive-oil; (3) three medium-sized onions, sliced finely lengthwise; (4) two tablespoonfuls of picked, roasted coriander-seeds ground to a paste with a little water; (5) one teaspoonful of clean ripe cumin-seeds roasted, and ground to a fine pulp with water; (6) one teaspoonful of the large variety of black mustard-seeds reduced to a stiff paste, mixed with water; (7) four large, selected, hot, long-podded, red chillies, preferably fresh, ground to a fine paste; (8) eighteen or twenty large, black peppercorns, broiled and ground to a paste with water; (9) seven fragrant vendium-seeds of the smallest variety, ground to a very fine powder and mixed with a little water; (10) a piece of fresh turmeric, or a bit of revived turmeric rhizome, about an inch in length, ground to a stiff paste; (11) half a clove of fresh garlic, sliced and then mashed finely, or enough pulped garlic to yield about a quarter of a teaspoonful; (12) half a lime, or small lemon; (13) one coconut; (14) one teaspoonful and a half of salt; (15) one dessertspoonful of moist sugar; (16) sufficient water."

**CURRIES**—Any kind of meat, fish, game, or vegetables, cooked with curry powder, is called a curry of that particular kind. **CURRY OF LAMB**—Some onions are fried brown in butter, then taken out; a tablespoonful curry powder wetted with water stirred into the onion-butter and cooked 10 minutes; meat cut small, an onion, an apple; all stewed in the curry sauce for one or two hours, with broth added if needed. The meat to be tender enough to be eaten with a spoon; browned onions mixed in; served with rice.

**CURRY QUOTATIONS**—*For menus*: "When you talk of Ceylon and the picturesque city of Colombo and the ancient city of Kandy, your thoughts naturally revert to curry. The prawn curry of the Grand Oriental Hotel in the old Dutch port at Colombo is renowned throughout the East; and they

## CUR

give you with it—in addition to Bombay ducks—'poppedoms,' if that be the right way of spelling the articles in question, something like passover-cakes fried in ghee or liquefied butter."—"Many of the London clubs have their culinary specialties. Thus, the Oriental, in Hanover Square, has long been celebrated for its curried prawns; the Garrick for its porter-house steaks and marrow-bones; the Junior Garrick for its mutton broth; the Windham for a dish known as 'all sorts,' named after the 17th Lancers; another club for its tripe and onions; while the grill at the little Beef-steak, over Toole's Theatre, is unique."—"The secret of making curried prawns in perfection is to flavor them with tamarinds."—"A little tamarind, scraped apple, or lemon juice may now be added to impart the much-desired sub-acid flavoring, and lastly, a cupful of cocoanut-milk about three minutes previously to dishing up." "Colonel Yule, in his 'Glossary of Anglo-Indian Terms,' cites a passage, quoted by Athenæus from Megathenes, which is said to be the oldest indication of the use of curry in India. The earliest unequivocal mention of it is in the Mahavauso, the earlier chapters of which date from the fifth century, A.D. But it is as precisely referred to in another of the ancient books of Ceylon, the Rajavali, which is, I believe, held to belong, at least in its original form, to the second century, A.D."—"Boiled rice should always be served with every kind of curry, and, as a rule, it should be served separate and handed before the curry. The orthodox fashion of helping one's self to curry, is to take a spoonful of rice and place it on a plate, making a well in the center. The curry itself should then be placed in the middle, and the whole eaten with a fork. The rice should be so boiled that every grain is not only tender, but separated from every other grain."—"A spoonful of the cocoanut kernel, pounded, gives a very delicate flavor to a curry of chicken."—"All curries are the better for a suspicion of a sweet acid taste. The juice of a lime, with moist sugar dissolved in it, answers very well, or a tablespoonful of red-currant jelly and one of chutney, or a tablespoonful of sweet chutney and the juice of a lime or lemon; any of these combinations will give the desired sub-acid flavoring." **HOW TO SERVE**—"Serve the curry by itself in a side dish, separate from the rice. One tablespoonful of curry ought to suffice for six tablespoonfuls of rice, and should be partaken of with a dessert-spoon and fork, and not with a knife and fork. A teaspoonful of *Burmese Mango Chutney*, taken with a plateful of rice and curry as above, will be found very acceptable by most persons. Rice and curry should not be made a principal dish at dinner: its true place on the *menu* is, without doubt, a final *entree*."—"NABOB CURRY—Consists of small pieces of minced meat, which are rolled into balls about the size of a marble. These marbles are then floured and fried (if possible in the curry fat) and sent to table with the curry sauce poured round them. SYKABOB CURRY—Consists of slices of meat,

## CUR

potato, onion and green ginger, stuck on a skewer. These are served up in the curry, thus skewered together. One of the most delicious curries known is the CINGALESE PRAWN CURRY—This dish can be made either from fresh prawns or from canned or potted ones, which are cheaper, but not so good. The Baratavia prawns are the best kind canned. In making curry from fresh prawns, the white meat of the prawn is served up in the curry sauce, but be sure and take all the heads off the prawns and pound them in the curry sauce, so as to extract what may be called the goodness out of the head—the little lumps which correspond to the green part of a lobster. VEGETABLE CURRY—Is exceedingly nice, and is not so often met with in this country as it deserves. Every kind of vegetable can be used mixed together, and a very nice simple dish can be made by merely opening a tin of *macedoins*. CURRIED SAUSAGES—Form a very nice breakfast dish, which simply consists in pouring curry sauce over some fried sausages. CURRIED SARDINES, OR PILCHARDS—Form an excellent breakfast dish.

CURRANTS—*Zante Currants*; a kind of small raisins used in fruit cake and puddings. The largest and cleanest are the most economical to buy, as the inferior grades are little else but dirt and stems. To clean currants, they should be washed in a perforated colander, set in a pan of water, and stirred around that the trash may fall through the holes.

CURRANTS—*Garden Currants* are of three kinds and several varieties; the red and white are nearly alike and are used for the table and for cooking and making currant jelly; the black currant is distinct in flavor and used to a limited extent as a pie fruit and for wine. These currants only reach perfection in a moist and cold climate. GREEN CURRANT PUDDING—Currants before they are ripe picked from stems, filled into a bowl lined with short paste, well sugared, covered with a paste top; tied down in a cloth; boiled an hour or more. RED-CURRANT JELLY—Is made by boiling 1 pint expressed pulp and juice with 1 lb. sugar. CURRANT LIQUEUR—A cordial; made of 2 lbs. red currants, 2 qts. whisky, thin rind of 4 lemons, 2 oz. ground ginger; let stand 48 hours, then strained through flannel jelly bag; to each quart 1 lb. sugar dissolved and boiled to syrup; well mixed; then bottled. ICED CURRANTS—Ripe currants sugared over or frosted by dipping in white of egg beaten with little water; then rolling in powdered sugar and drying for the table. Other uses for pies, ices, etc., same as other fruits.

CUSSY (*de*)—A name often met with in relation to gastronomical subjects. "The Marquis de Cussy was a notable man enough in his day. It was he who was escorting the Empress Marie Louise back to Vienna when at Parma he heard of Napoleon's escape from Elba. Planting her there, he retraced his steps immediately and found his master back at the Tuileries, where he himself was an excellent

## CUS

prefect of the palace; but, the Hundred Days once over, he found himself suddenly a pauper, having always managed to combine indifference to his own interests with lavishness to others. This and his charms of manner made him popular, and he possessed that first talent of a born conversationist—a lending ear. But he was a born *gourmet*, too, and fully acted up to Colnet's line: 'Quand on donne à dîner, on a toujours raison.' Great cooks struggled for his kitchen, and stayed with him seven years. He gave a dinner once a week, never to more than eleven guests, and it lasted two hours. He cites with approval in his 'Art Culinaire' one of the stories about that very unpleasant person Diogenes, who, seeing a child eating too fast, fetched the boy's tutor a rousing cuff. De Cussy's own rigid rule was to eat moderately and to sip his liquors; and he preached putting down the knife and fork while still hungry, and then taking several glasses of an old wine, munching crisp breadcrust the while. Perhaps these were some of the reasons why the camel never refused, and explained his 'easily digesting a whole red-legged partridge' on the very day of his death, at the age of seventy-four. Many a well-advised man nowadays would as soon eat Tom Jones' Partridge body and bones; and there have been what a vain world calls nobler deaths, to be sure, and different illustrations of Hamlet's grave dictum that 'the readiness is all;' still we need not be too exclusive. This particular *gourmet* had the smooth-skinned, pink complexion of many an old-fashioned London merchant—in the daytime, that is; but a clever caricature of him by Dantan, which displays the bust of a heavy-chopped, bloated old gormandizer, with a great Yorkshire pie for pedestal, must also have been too near the truth, perhaps, after dinner; for one of his sayings to Brillat-Savarin, who would have mirrors in his dining room, was that a man should only look in the glass fasting. After this it would be of no use at all his telling us that he could take up his pen immediately after dinner in full possession of his ideas, if we did not know from his sorry writings that he could not tack two ideas together, and that, whatever his practice was, his theories about cookery were not worth the charcoal for testing them." De Cussy is quoted nowadays occasionally, because he *did* write of *L'Art Culinaire*, and of *Carême*, and of his contemporary *gourmets* and entertainers. "M. de Cussy, who, when young, had been patronized by Marie Antoinette, and who in later years was about the court of Marie Louise, failed to obtain a small place under Louis XVIII till the discriminating monarch was told that the mixture of strawberries, cream, and champagne, which possesses such a refined flavor, was the creation of the aged *gastro-nome*." CONSOMME A LA CUSSY—Game broth; *royale* custards made with 10 yolks, 2 eggs, 1 pint purée of game and little cream; game meat, mushrooms and boiled chestnuts served with it.

CUSTARD—A mixture of milk and eggs, cooked

## CUT

only to boiling point, generally with sugar and flavorings added. The standard rule is 8 eggs to 1 qt. milk and 6 oz. sugar; but custard is made with 4 eggs to a quart, also with 8 yolks only; also with 2 or 3 eggs and flour or starch to substitute the remainder. Custard, whether boiled, steamed or baked, is thickest and perfect only when it reaches the boiling point; with longer cooking it turns thin and separates into curd and water. **CUSTARD PUDDING**—Firm enough to turn out of mould; made of 1 pint milk, boiled with stick cinnamon and grated lemon rind, cooled, mixed with 3 yolks and 5 whole eggs well whipped, and sugar. Steamed in mould till set. **CUSTARD FLAVORINGS**—Orange flower water, orange extract, lemon, vanilla and rose, bay leaf, nutmeg, cinnamon, almond. **CUSTARD PIE**—Plate lined with short-paste, filled to the brim with raw custard, baked till set. **CUP CUSTARDS**—Boiled custard, made by pouring boiling milk, sweetened, to whipped eggs, or eggs and starch, and cooking only till about to boil again; filled into custard cups. **CHOCOLATE CUSTARD MERINGUES**—Boiled custard with 1 oz. chocolate in each quart, filled in cups, whipped whites and sugar on top lightly browned. **CUSTARD PUDDING**—Plain custard baked in a pudding dish. **COCOANUT CUSTARD**—Cocoanut mixed in raw custard to bake or in the hot milk for boiled custards. **CUSTARD ROLY-POLY**—Custard made firm with 12 eggs, steamed, then sliced on a thin sheet of paste; strawberry jam spread upon the custard, all very thin, rolled up in a pudding cloth, steamed 1½ hours; served with sauce.

**CUTLETS**—Chops, meaning the rib bone chops, veal steaks are, however, called cutlets. There are cutlets proper of lamb, mutton, pork, venison, veal, but not of beef; the cutlets of beef are called *entre-cotes*, steaks and collops or scollops; cutlets of small meats, lobster, and such things are imitations of the shape of cutlets.—(See *Cotelettes*.)

**CUTTLE FISH**—The octopus, or devil-fish. "Next to whales, probably the most bulky animals in the sea are the gigantic cuttle-fishes, with which we have recently become acquainted. Of the largest of these the body would be quite equal to an elephant. They are not seen often enough to enter a list even of extraordinary foods; but smaller cuttle-fishes are beloved of many men, especially by Italians; and in the sea-shore markets near Naples you may find tubs full of writhing octopods exposed for sale. When a purchaser arrives and makes a selection the vender adroitly seizes the fish by the back of the neck, the arms twisting and extending in all directions. It is dropped into the scales, and if approved of the salesman gives it a twist, almost turning it inside out, killing or disabling it in a moment. To see a mess of chopped full-grown octopus served with tomato sauce is really trying. When very small the octopus is used as a garnish for fish, and when fried crisp it might be mistaken for macaroni. Neapolitans come properly by their taste for the cuttle, since

## DAR

the Latins ate it, and have handed down a recipe for a cephalopod sausage. Pickled, you may find cuttle-fish arms, suckers and all, among our fancy groceries; and in San Francisco you may buy tons of preserved cuttles. These are a Chinese preparation of the squid. It is split open, cleaned, spread out flat, and dried and then resembles a Cape Ann cod-fish slitted into shreds at the broad end. Boiled and mixed with seasoned herbs, a popular soup or porridge results, the taste of which is mildly that of lobster broth."

**CYGNET**—Young swan. (See *Swan*.)

**CYMLING**—Summer squash.

## D.

**DAB**—A small flat fish found near the mouths of rivers; good to fry or broil.

**DAIM** (Fr.)—Deer; fallow deer. **COTELETTES DE DAIM**—Venison cutlets. **CUISSOT DE DAIM**—Leg of venison.

**DAMSON**—A black plum of high flavor; much esteemed for cooking purposes. Name from Damascus, whence it came. Formerly called the Damascene plum. A very similar plum grows wild in some parts of the southern states. **DAMSON CHEESE**—Pulp of steamed damsons passed through a seive, ½ lb. sugar to each quart of pulp, dried down by slow boiling and stirring till it makes damson butter stiff enough to be cut in pieces when cold. Served for dessert, and to be dissolved for tarts and cakes as wanted. **PAIN DE PRUNES DE DAMAS**—A mould of damson cheese, or of marmalade diluted and set with gelatine.

**DAMP CELLARS**—If the air of the cellar be damp, it can be thoroughly dried by placing in it a peck of fresh lime in an open box. A peck of lime will absorb 7 lbs., or more than 3 qt. of water, and in this way a cellar or store-room may soon be dried.

**DANDELION**—The well-known plant with yellow flowers which change to thistle-down. The leaves gathered young are among the best of early greens; cooked the same as spinach, with a pinch of soda in the water, drained, chopped and seasoned. **DANDELION SALAD**—The young leaves are eaten in salad in place of endive or lettuce. **DANDELION WINE**—A simple sort of domestic wine made of the petals of the dandelion flower and sugar. **DANDELION COFFEE**—The root has been mixed with coffee during the past 25 years, and sold as "dandelion coffee," a hygienic beverage.

**DANTZIC GOLD JELLY**—Jelly having gold leaf carefully mixed in it to make it sparkle; flavored with Dantzic *gold-wasser*.

**DARIOLE MOULDS**—Tin or copper moulds of about the size and shape of a common small glass tumbler. They are either plain or fluted, with or without a pattern stamped in the bottom. The name is rarely used in this country, but the moulds are in use everywhere as *charlotte russe* moulds of indi-



## DAR

vidual size, and are used for small steamed puddings and for blanc mange and jelly.

**DARIOLES**—Almost anything that is made shaped, steamed, baked or moulded in a dariole mould is called a dariole. Deep patties of a pastry crust filled with some kind of custard or stiff cream, flavored either with vanilla or chocolate seems to have been the original sort of dariole, which is not as rich as a cheese cake, but nearly the same thing.

**DARNE** (Fr.)—A thick cut of salmon or sturgeon. **DARNE D'ESTURGEON AU FOUR**—A thick slice of sturgeon baked.

**DATE**—Fruit of the date palm. **DATE PIE**—Made like squash pie; 1 qt. milk, 2 lb. dates, 3 eggs; the dates boiled in the milk and rubbed through strainer. **DATES FOR DESSERT**—The stone removed and a blanched almond put in its place. **DATE CREAM**—Sugared dates; a candy bon-bon.

**DAUPHINES**—Tartlets; patty pans lined with paste, preserve or jam first; custard on top; baked and then meringued like a lemon pie.

**DECORATION**—"A few days ago I saw a beautiful exception, which combined simplicity with grace and artistic effect: it was a ham glazed in the usual manner, but decorated only with a large spray of imitation lilies of the valley; the stems and the leaves were cut from cucumber-peel, and the little flowers simulated by cutting thin slices of boiled white of egg to shape. It will be easily understood that the thinly cut cucumber-peel lends itself very kindly to the subject; the bright green color, the fine stems bowed with the weight of the flowers, and the leaves raised and twisted into natural positions, would satisfy a culinary Oscar Wilde. The idea can be easily extended: with the yolk and the white of an egg, beat together and steamed into an extra firm *a la royale* custard, primroses can be imitated. Fuchsias can be done easily by cutting them from long radishes, and lemon-peel might be persuaded to turn itself into a flower of fancy; in all cases, the stems and leaves appropriately cut in cucumber-peel."

**DELMONICO PUDDING**—A corn-starch meringue, made of 1 qt. milk, 4 oz. starch, 4 oz. sugar, 5 yolks, 1 oz. butter, little salt; made up same as a lightly cooked custard; poured in baking dish; marmalade spread over; meringued with the whites; baked.

**DEMI-GLACE SAUCE**—The brown coating of the pan, which is the gravy-drippings from baked meat, freed from the grease, dissolved with broth, thickened transparently with starch and strained. It is the meat gravy served with it; becomes a clear brown by slow boiling.

**DEVIL-FISH**—(See *cuttle-fish*.) "The devil-fish is said to be rapidly multiplying in the waters of San Francisco bay. One of the fearful creatures was exhibited in the San Francisco markets a few days ago and attracted many visitors. The fish was about 9 feet in length and presented a most repulsive

## DIA

sight. Notwithstanding the latter fact, one of the tentacles was sold to an Italian for food before the monster had been on exhibition over an hour. The sons of Italy prize the tentacles most highly, the ordinary mode of eating them being to fry them or boil them in oil."

**DEVILLED MEATS**—Broiled or grilled meats variously sauced. **DEVILLED KIDNEYS**—Broiled kidneys with salt and cayenne. **DEVILLED HAM**—Broiled slices of ham with a sauce of mustard, pepper and chopped pickles. **DEVILLED BONES**—Spare-ribs or chops with Robert sauce. **DEVILLED LOBSTER**—Lobster split lengthwise and broiled in the shell; served with devil sauce. **A DRY DEVIL**—Leg of turkey or any kind of meat peppered and salted, coated over with made mustard, and broiled. **A WET DEVIL**—Leg of roast turkey, with cuts in it, seasoned with mustard, pepper and salt; broiled; served with devil sauce.

**DEVILLED OYSTERS**—Philadelphia specialty. Same plan as devilled crabs; the oysters chopped small, drained, put into thick butter sauce with yolks and parsley, salt, cayenne; baked in oyster-shells with bread-crumbs on top.

**DEVIL SAUCE**—(1)—Made of 3 tablespoons each butter and meat gravy; large teaspoon each cayenne and sugar; 1 glass each mushroom catsup and white wine; juice of 1 lemon; made warm. (2)—Butter, gravy, Harvey's sauce, catsup, Chili vinegar, mustard, glass of port, juice 1 lemon, cayenne, black pepper, salt. (3)—Chopped shallots fried in butter, 2 ladles espagnole, 1 of broth, 2 tablespoons made mustard, Worcestershire and cayenne; strained.

**DEVONSHIRE JUNKET**—Devonshire, the home of the Devon breed of cattle, is famous for dairy products and for clotted cream. The "junket" is curd and cream: 1 qt. milk, 1 tablespoon sugar, vanilla to flavor, a little rennet or rennet powder added, poured into a glass dish, where in a warm place in about 20 minutes it becomes sweet curd. Then a thin layer of clotted cream is spread over it. Eaten with strawberry jam.

**DEVONSHIRE SQUAB PIE**—A pie made of mutton chops and sliced apples in alternate layers, the apples on bottom first with sugar and spice, meat on them with salt and pepper; little water, a top crust of paste, baked 1½ hours. (See *squab*.)

**DEVONSHIRE CAKE**—A yeast-raised cake; made up with cream, currants, citron, sugar, saffron, baked like bread in tins.

**DEWBERRY**—A variety of blackberry which grows prostrate upon the ground; ripens early, well flavored, superior pie fruit.

**DEXTRINE**—British gum, obtained by boiling starch, which changes with heat into gum. Used for making various kinds of gum drops, fig pastes, "Turkish delight," etc.

**DIABLOTINS AU GRUYERE**—Paste made

## DIA

like cheese straws with eggs added, formed in little balls, floured, fried.

DIABLE SAUCE—Devil sauce.

DINDON (Fr.)—Turkey. DINDE—Hen turkey. DINDONNEAU—Young turkey. DINDONNEAU A LA DUCHESSE—Young turkey roasted, served with a ragoût of pieces of tongue, quenelles, green beans and cucumber. DINDON TRUFFE—Breast of chicken, goose liver, bacon and truffles are chopped, seasoned with salt, pepper, and a bay leaf, simmered in stock; 2 doz. whole truffles added, stewed half an hour, with constant stirring. Turkey stuffed with it, sewed up, hung 4 days, covered with slices of bacon and buttered paper and roasted. Truffles in the sauce.

DIPLOMATIC PUDDING—(1)—A *creme* in a decorated casing of jelly, made of a yolk-of-egg custard with sugar, gelatine and cream mixed in, flavored with brandy and vanilla. A plain mould is coated with wine jelly by turning it about in ice, decorated with candied fruit, the custard *creme* poured in; solidified on ice, turned out on a folded napkin. (2)—A *creme* without jelly casing made of a yolk-of-egg custard with gelatine, sugar and cream; a mould in ice decorated with fruit dipped in jelly; a layer of *creme* poured in; on top of that a layer of sliced sponge cake dipped in maraschino, then candied fruits, then cream etc. Set solid on ice.

DIPLOMATE SAUCE—(1)—Another name for cardinal sauce, made of Bechamel sauce with lobster coral or lobster butter reddened, anchovy essence, cayenne bits of butter, all well whisked, served with fish, hot. (2)—It is Bechamel sauce flavored with crayfish and crayfish butter.

DIP SAUCE—Sweet diplomate; a pink sugar-and-starch sauce, thick, clear; any flavor.

DOG-FISH—"Dog-fish is not bad, salted. It is sometimes called 'Folkestonte beef,' and is much eaten in Lancashire."

DOMBEY PUDDING—Delicate sort of plum pudding, steamed or baked; made of  $\frac{1}{2}$  pt. cream, 4 oz. sugar, rind of 1 lemon, made hot in saucepan and 6 tablespoons bread-crumbs, 1 spoon flour, 3 of suet, 1 marrow. Boiled and stirred to paste, then mixed with 2 oz. each of currants, candied orange peel, sultana raisins, 4 eggs, little nutmeg, 1 glass each wine and rum; served with orange sauce containing rum.

DORY—A fish. (See *John Dory*.)

DOUCETTE (Fr.)—Corn salad; a kind of cress.

DOUGHNUTS—Fried cakes; pieces of sweetened bread dough in ring or twisted shapes allowed to rise, then dropped in hot lard and fried light brown. BAKING POWDER DOUGHNUTS—1 qt. flour, 1 small cup sugar, lard size of an egg, 2 tablespoons baking powder, 2 cups water or milk. Rolled out, cut in shapes, fried, sugared over when done.

DOUGH-MIXERS—There are machines made

## DRI

to do the heavy work of mixing dough in large quantities.

DOUGH TROUGH—A long wooden box about 18 inches deep and raised 6 inches from the floor, made with flaring sides and a moveable partition. Used by all bread makers and needed in all hotels to mix up bread dough in. The lid should be in two halves, not hinged, but removable that half may be used at once as a table.

DOUGH-RAISERS—Various contrivances, the subject of many patents, for keeping bread-dough at as nearly as possible a temperature of 80 degrees while rising, that the fermentation may be perfect; especially needed in cold weather. Where houses are steam-heated a closet is made for this purpose. A home-made contrivance is a barrel with a pail of hot water set in it, the pan of dough set in the barrel above it, and a blanket over all.

DOVER BISCUITS—Made of 6 oz. each sugar and butter, 2 eggs, 12 oz. flour. Like cookies.

DRAWN BUTTER—English name for butter sauce; made by stirring equal measures of butter and flour together over the fire, adding boiling water sufficient, and beating in more butter at last.

DRESDEN PATTIES—Croustades made like patties, the inside of the rounds of fried bread to be removed and a filling of any kind put in.

DRINKS—Stewards and caterers have to provide for parties: ALE CUP—Made of 2 qts. ale, 1 pt. gin, 3 oz. brown sugar, 3 yolks, ground ginger, cinnamon, nutmeg, yolks, etc.; beaten; hot ale poured in.

MULLED CLARET—Two bottles claret, 4 oz. sugar, rind 2 lemons, 6 cloves, 4 inches cinnamon, 1 glass brandy; spices and sugar boiled in little water; claret added and made hot; brandy in at last. TOM AND JERRY—Five pounds sugar, 12 eggs,  $1\frac{1}{2}$  teaspoons

ground cinnamon,  $\frac{1}{2}$  teaspoon each cloves and allspice,  $\frac{1}{2}$  glass rum; eggs separated and beaten, mixed again; rum, spice and sugar added; served by taking 1 tablespoon of the mixture, adding 1 wine-glass of brandy, and filling up the glass with boiling water. FANNY'S DELIGHT—Four ounces sugar in 1 pt. boiling water, with 4 cloves,  $\frac{1}{4}$  oz. cinnamon and  $\frac{1}{2}$  oz. ginger; strained; added to 2 yolks; beaten up, and 1 glass raisin-wine, 1 glass ginger-wine added. EGG FLIP—Four eggs, with 2 of the whites omitted, beaten up with 2 tablespoons sugar, 1 pint boiling water added by slow degrees, 2 wine-glasses brandy, 1 wine-glass rum. WASSAIL BOWL—One quart hot ale; nutmeg, ginger, cinnamon,  $\frac{1}{4}$  oz. each;  $\frac{1}{2}$  bottle sherry, 2 slices toast, 2 roasted apples, 1 lemon; sugar to taste. GABE CASE PUNCH—Three bitter Seville oranges, roasted to a pale brown color, laid in a heated vessel, 1 lb. sugar pressed with them, 2 bottles warm Burgundy, 1 pint hot water. LANGTRY PUNCH—One orange stuck full of cloves and roasted before the fire, cut in quarters, 1 quart hot port wine poured over it, sugar to taste; simmered half an hour. A REVIVER—Two yolks in a goblet, with 1 oz. honey, little essence of cloves, liqueur-

## DRI

glass of curaçao, 1 pt. hot Burgundy; whisked together; served hot in glasses. **COLD MILK PUNCH**—Half pint tumbler filled with chipped ice, 1 teaspoon sugar, 1 wine-glass brandy, 1 liqueur-glass rum; filled up with milk; shaken; straws. **MINT JULEP**—Large glass, 1 teaspoon sugar, little water, 3 sprigs mint; all pressed together; mint taken out,  $\frac{1}{2}$  wine-glass brandy,  $\frac{1}{2}$  liqueur-glass rum, ditto yellow chartreuse; filled up with ice; shaken; then topped with fruit and mint, dash of claret and sugar to finish; straws. **JOHN COLLINS**—Half pint tumbler filled with chipped ice, 1 teaspoon sugar, juice of  $\frac{1}{2}$  lemon,  $\frac{1}{2}$  wine-glass gin; filled up with soda water; straws. **LEMON SQUASH**—Large glass filled with chipped ice, juice of 1 lemon,  $1\frac{1}{2}$  teaspoons sugar; filled up with soda; stirred; fruit on top; straws. **SODA COCKTAIL**—Large glass half filled with ice,  $\frac{1}{2}$  teaspoon Angostura,  $\frac{1}{2}$  teaspoon sugar; filled up with soda; lemon-peel on top; straws. **CLARET PUNCH**—Half pint tumbler filled with chipped ice, juice of  $\frac{1}{2}$  lemon, 1 teaspoon sugar, 1 teaspoon raspberry syrup, claret to fill up; shaken; ripe fruit on top; straws. **GIN SLING**—Half pint tumbler filled with ice, 1 lemon-glass plain syrup; juice of  $\frac{1}{2}$  lemon,  $\frac{1}{2}$  glass gin; filled up with soda; slices lemon and orange on top; straws. **GIN COCKTAIL**—Tumbler filled with chipped ice, few drops Angostura and plain syrup,  $\frac{1}{2}$  wine-glass gin; stirred well; strained off into cocktail glass; piece lemon on top. **GIN SOUR**—Tumbler filled with ice,  $\frac{1}{2}$  teaspoon sugar, 1 teaspoon raspberry syrup, juice  $\frac{1}{2}$  lemon,  $\frac{1}{2}$  wine-glass gin; strained into cocktail glass, lemon-slice on top. **EGG NOGG ICED**—Tumbler filled with chipped ice, 1 raw egg, 1 teaspoon sugar, 1 liqueur-glass brandy, 1 do. rum; shaken well; strained off into pony tumbler; nutmeg on top. **SAM WARD**—Tumbler filled with chipped ice, 3 or 4 drops Angostura, 1 liqueur-glass green chartreuse; shaken well; strained into cocktail glass. **CORPSE REVIVER**—A long, thin liqueur-glass filled with equal portions noyau, maraschino and yellow chartreuse, one on top of the other without mixing them; to be taken off at one draught. **PRAIRIE OYSTER**—A wine-glass with  $\frac{1}{2}$  teaspoon vinegar, 1 new-laid egg, little salt, pepper and dash of Worcestershire sauce; to be drunk off raw.—**GIN PUNCH**—“At the Garrick Club they serve an excellent gin punch, which, according to Mr. Percy Fitzgerald, is ‘brewed’ as follows: Pour half a pint of gin on the outer peel of a lemon, then a little lemon juice, sugar, a glass of maraschino, about a pint and a quarter of water, and two bottles of iced soda-water; this makes three pints.” **ABSINTHE**—The proper way to serve *absinthe au sucre* is thus: Put two lumps of sugar in a strainer which just fits the top of the glass, and let the absinthe trickle slowly through; the water is added afterwards. **TIGER'S MILK**—An East Indian morning draught, not generally known. Add the beaten yolks of 3 eggs to 2 tablespoonfuls of powdered white sugar, 3 cloves, the rind of  $\frac{1}{2}$  lemon, and  $\frac{1}{2}$  pt. of Impe-

## DRI

rial Crown brandy; pour over it 1 qt. of new, warm milk, stirring rapidly, and serve immediately. This is recommended for those who live in malarial districts, and for delicate persons before breathing the crisp air of autumn or winter. A wineglassful will be sufficient in this climate. **SAUTERNE CUP**—1 bottle sauterne, 2 sliced peaches, 1 liqueur glass noyau, juice of 1 lemon, ice, leaves of balm and borage, 1 bottle soda-water. **BURGUNDY CUP**—2 bottles red Burgundy, 1 pt. port, 1 gill cherry brandy, juice of 2 oranges and 1 lemon, a slice of cucumber, sprig of verbena, sugar, ice, 3 bottles seltzer-water. **CHAMPAGNE CUP**—1 bottle champagne, 1 liqueur glass curaçao, same of pale brandy, sprig of verbena, slice of cucumber, ice, 2 bottles soda. **CLARET CUP**—(1) 1 bottle claret, 1 pt. sherry, 1 gill port, do. cherry brandy, 1 lemon, sugar, cucumber thin slice, verbena, ice, 3 bottles seltzer water. (2)—One bottle light claret, 1 glass brandy, 1 lemon peeled thin,  $\frac{1}{2}$  pt. water, sugar, sprig of borage, some slices of cucumber; in jug well iced. **BRANDY CHAMPERELLE**—One wine-glass each curaçao, brandy and bitters, with shaved ice. **PORT NEGUS**—One bottle port, peel of 1 lemon, 2 crushed cloves, grated nutmeg, sugar to taste, 1 qt. boiling water. **CHAMPAGNE COCKTAIL**—A large lemonade glass half filled with shaved ice, 2 drops each orange, lemon and gentian essences; 1 tablespoon each orange-flower water and syrup; well shaken; 1 glass champagne added. **JERSEY COCKTAIL**—Large glass with ice, essences, syrup and champagne cider. **BRIDAL BOQUET CUP**—Two quarts thin, clear syrup,  $\frac{1}{2}$  pt. orange-flower water, 1 pt. lime juice, 1 tablespoon noyau; served  $\frac{1}{2}$  glass of this mixture with iced soda and  $\frac{1}{2}$  glass champagne. **LIQUEUR EUSTACHE**—Large glass half filled with ice, 2 tablespoons syrup, rind of a lemon tied in a knot, juice of  $\frac{1}{2}$  lemon, 1 liqueur-glass cognac,  $\frac{1}{2}$  glass absinthe; filled up with soda; stirred. **BRITISH LION**—A liqueur-glass Scotch whisky, 1 tablespoon each cherry-syrup, lime juice and bay rum, peel of  $\frac{1}{4}$  lemon in glass filled up with boiling water. **CINDERELLA CUP**—One bottle raisin or angelica wine,  $\frac{1}{4}$  pt. strong syrup mixed in a bowl, 1 qt. lemonade, ice, sprigs of scented verbena. **LIQUEUR SUPREME**— $\frac{1}{4}$  pt. each maraschino, kirschwasser and curaçao,  $\frac{1}{2}$  pt. strong syrup, 1 bottle brandy, or champagne. **CASK GINGERADE**—In a 10-gal. keg: 9 gal. syrup 1 pt. essence ginger,  $\frac{1}{2}$  pt. essence lemon, 1 oz. yeast, 1 oz. isinglass; bunged up with cotton 3 days; then corked tight, or bottled and wired. **JERSEY LILY JULEP**—Large lemonade-glass half filled with shaved ice, 1 tablespoon sugar, 1 wine-glass cognac, 1 glass champagne, sprays of jessamine or orange flowers, nutmeg, dust of sugar on top. **ROSE NECTAR JULEP**—Lemonade-glass with ice,  $\frac{1}{2}$  glass each rose nectar and cognac; 1 spoon sugar, 4 slices lemon, red rose buds dusted with sugar, rim of glass rubbed with lemon; straws. **CHRISTMAS JULEP**—Large lemonade tumbler, the rim wet with whisky and dipped in powdered sugar to frost it;  $\frac{1}{2}$  filled with ice, 1

## DRI

tablespoon sugar, 1 spoon maraschino,  $1\frac{1}{2}$  wine-glass whisky, piece lemon-rind,  $\frac{1}{2}$  pt. milk; stirred; bay leaf dusted with sugar set in; straws. **MOSELLE CUP A LA PRINCE DE GALLE**—A punch-bowl made ice-cold; 1 pt. rye whisky, 1 bottle pale sherry, 2 drops ambergris, 1 drop musk-essence, 2 tablespoons grated pineapple, spray of verbena; all set on ice for 2 hours; then added 2 bottles sparkling Moselle. **PUNCH A LA SANDRINGHAM**—One pint new-made green tea, 4 oz. sugar, 2 tablespoons port-wine jelly dissolved in the hot tea, 1 lemon sliced in, 1 bottle whisky, 1 glass brandy, 3 drops ambergris. **YPOCRAS**—“‘To make ypcras hit were gret lernynge.’ The ‘ypocras’ would not be acceptable to a generation which likes the curaçao dry. Red wine was the foundation of this drink, and to it there were added ginger, cinnamon, spices of various kinds, sugar-candy and other condiments, according to whether the drink was being brewed for those of high degree or for common people. The butler is to taste it constantly, ‘allday,’ the writer declares, and if the result be not perfect, ginger, cinnamon or sugar is to be added until it is all that it should be.” **BRANDY PUNCH**—One-half pint water with  $\frac{3}{4}$  lb. sugar, peel of 2 lemons, little cinnamon, nutmeg, mace, cloves; all simmered, strained, and 1 bottle brandy, juice of 2 lemons, very hot; set on fire in bowl, and served burning. **PHILADELPHIA COOLER**—“The latest drink, and the one that is all the rage in Saratoga, is the ‘Philadelphia cooler.’ It was first made by bartender A. D. Kibbe, who has mixed beverages at the United States for fourteen years; but it can be got at either of the three other first-class bars. As it is made of champagne, and costs something like a dollar a drink, it fitly represents the two main characteristics of the season—champagne drinking and extravagant pleasures. There never was so much money on tap at Saratoga as at present, and the interest taken in champagne by the drinkers is phenomenal. With the King of the Dudes backing one brand, Monsieur Lippa treating to another, and a private individual rushing his favorite simply because he believes it better than any other and does not want the fact overlooked, there has been enough wine drunk to float a ship. The drink called the ‘cooler’ is prepared by half-filling two big glasses with cracked ice, putting in a little mint and two lumps of sugar, pour half a pint of champagne on top, and squeezing the mint with a crusher or mixer until its essence pervades the champagne. After a night spent in drinking coolers the average dude can find his way to bed—if one of the porters steers him correctly.” **CHAMPAGNE CUP (Saratoga)**—One bottle champagne, 1 qt.-bottle German seltzer-water, 2 oranges sliced, sprigs of balm and borage, 1 oz. sugar; in a covered jug imbedded in ice for 1 hour; then strained into decanter. **CIDER CUP**—One quart cider, 1 liqueur-glass brandy, 1 pt. seltzer-water, 1 oz. sugar, sprigs of balm and borage; set in ice for an hour; decanted. **ELECTRICAL COCKTAIL**—Is the latest American drink.

## DRI

According to *Electrical Review*, a flexible lead from the electrolier ends in a platinum curl. A trifle of sugar is added to the fluid, the platinum curl lowered into it, and the current turned on to make the curl red-hot. A small amount of the alcohol and sugar is carbonized, and the resulting burned-sugar flavor is said to be very delicate. It promises to be a fashionable winter-beverage, and can be made cold or hot.” **“IDLEWILD TODDY**—Is composed of half a lemon, half an orange, sugar, chopped ice, whisky, and just a dash of Santa Cruz rum. It is flavored with Benedictine cordial; then shaken and served in ice.” **FRUIT PYRAMID**—Half a lemon, 1 tablespoon each of lime juice and pineapple juice; 4 oz. sugar, (no liquors), ice; filled up with rich milk; shaken. **THE STEINWAY**—Sugar, whisky, ice and Apollinaris water. **THE DAISY**—Five drops Angostura bitters, lump of sugar rubbed on a lemon, 1 liqueur-glass port wine to dissolve sugar, shaved ice; filled up with ginger ale; shaken. **THE MAITRANK**—German specialty. A good-sized bunch of woodruff leaves in a bowl, with a bottle of still hock steeped an hour, 2 or 3 oranges sliced in, 1 liqueur-glass each chartreuse, maraschino and curaçao, 1 bottle sparkling wine, sugar to taste; served as a cold punch. **“THE PRINCE OF WALES**—Having invented the long drink called ‘lemon squash,’ has now added to his laurels by inventing a ‘short drink;’ consisting of rye whisky, powdered sugar, ice, a small piece of pineapple, some Angostura bitters, a little lemon-peel, a few drops of maraschino and a splutter of champagne.” **“EGG-LEMONADE**—Is a new beverage that barkeepers find it pay to include in their drink-list: Put into a pint-tumbler a teaspoonful of powdered sugar, the juice of 1 lemon, a little water and 1 egg; fill up with finely broken ice; then shake rapidly and briskly in a cobbler glass. It may be imbibed through straws.” **MILK SHAKE**—Shaved ice, sugar, milk; any flavoring as desired; well shaken to make foam. **CHARLIE PAUL**—Half-pint tumbler filled with shaved ice, 1 tablespoon raspberry syrup, 1 liqueur-glass brandy; filled up with new milk; shaken; straws. **MILK PUNCH**—Tumbler with ice, 1 teaspoon sugar, 1 wine-glass brandy, 1 liqueur-glass rum; filled up with new milk; shaken; nutmeg on top; straws. **WASHINGTON PUNCH**—Large glass of shaved ice, 1 teaspoon sugar,  $\frac{1}{2}$  liqueur-glass noyau,  $\frac{1}{2}$  wine-glass brandy; filled up with new milk; shaken; powdered sugar on top; straws. **ROYAL AQUARIUM MILK-PUNCH**—Six eggs, the yolks beaten with 8 oz. sugar; the whites whipped and then mixed in with 1 wine-glass curaçao, 1 bottle brandy, 1 bottle rum, 2 qts. new milk, 3 bottles soda; well mixed; enough for 25. **ATHENÆUM CLARET CUP**—“The following recipe for claret-cup is the one adopted at the Athenæum Club: The rind of half a lemon,  $\frac{1}{4}$  pint hot water poured on two ounces of sugar and 4 sprigs of borage; let it cool; add a bottle of good claret and 1 bottle of soda-water; put in  $\frac{1}{2}$  lb. of ice, and stir thoroughly; withdraw borage and serve. It will be observed that brandy or other liqueur is stu-

## DRU

diously excluded." **HOT PUNCH**—Four ounces loaf-sugar rubbed on a large lemon, juice of the lemon squeezed to the sugar in a bowl, 1 pint boiling water, added,  $\frac{1}{2}$  pt. each rum and brandy,  $\frac{1}{2}$  teaspoon grated nutmeg. **BEER CUP**—One quart porter or bottled beer, 1 teaspoon moist sugar, 1 slice toast, nutmeg, ginger; steeped together  $\frac{1}{2}$  hour. **POUSSE L'AMOUR**—One-half glass maraschino in a wine glass, 1 yolk on top,  $\frac{1}{4}$  glass vanilla cordial next,  $\frac{1}{4}$  glass brandy on top; not mixed or broken. **POUSSE CAFE**—Five drops raspberry syrup in a wine-glass,  $\frac{1}{4}$  glass each of maraschino, curaçao, chartreuse and brandy; the five colors not to be mixed or broken till drunk. **CHAMPERELLE**—One-third each brandy, maraschino, Angostura; in strata; not mixed. **BRAND SCAFFA**—One quarter each of raspberry syrup, maraschino, green chartreuse and brandy; in strata; not mixed. **GOLDEN SLIPPER**—Half wine-glass of yellow chartreuse, 1 yolk,  $\frac{1}{2}$  wine-glass Danziger goldwasser; not mixed, nor broken. **SHERRY FLIP**—Glass half-filled with ice, 1 teaspoon sugar, 1 egg,  $1\frac{1}{2}$  glasses sherry; shaken; nutmeg on top. **SHERRY COBBLER**—A tumbler of shaved ice, 1 tablespoon sugar, piece of lemon peel, essence of cloves, 1 tablespoon port, 2 glasses pale sherry; shaken, pineapple and orange slices and mint added; straws. **HARI-KARI**—Glass half filled with ice, 1 teaspoon sugar, lemon juice, 1 wine-glass whisky, filled with vichy water, fruits of the season on top. **WHISKY CRUSTA**—1 tablespoon gum syrup, 4 drops Angostura, juice of  $\frac{1}{2}$  lemon,  $\frac{1}{2}$  liqueur glass maraschino,  $\frac{3}{4}$  glass whisky,  $\frac{1}{2}$  glass shaved ice, mixed, poured into glass, the edge frosted with sugar. **ARCHBISHOP**—Tumbler with shaved ice, 1 tablespoon sugar, juice of  $\frac{1}{4}$  lemon and  $\frac{1}{2}$  orange,  $\frac{1}{2}$  liqueur glass rum, filled up with Burgundy, stirred; straws. (*See hot beverages, wines, spirits.*)

**DRUM FISH**—Southern sea fish; like the black grouper, weight from 1 to 8 or 10 pounds; so named because shoals of them butt against vessels, wooden piers, etc., making a drumming noise.

**DRY BREAD**—Pieces thoroughly dried, crushed and sifted form the bread-crumbs used for bread-*ing* and frying.

**DUCHESS CRUSTS**—Small cubes of bread fried brown, served with soup.

**DUCHESS LOAVES**—Ancient name of cream puffs.

**DUCHESS POTATOES**—Potato mashed with yolk of egg and salt, made into flat ornamental shapes, egged over, baked; to serve with fish and for garnish.

**DUCK**—**TOULOUSE DUCK**—"As every restaurant of any note in Paris, so does every town in France, pique itself on some particular dish. So it is that the citizens of the different towns temporarily located in Paris meet together on fixed and solemn occasions to partake of the dish of their town. Now ask a Toulousian what, next to the cholera, his home is cel-

## DUC

brated for, and he will answer you, probably, as he answered me, '*Canard a la mode de Toulouse.*' Do you want to know how to make it? Take a young duck, bone it; now take half a pound of calf's liver, minced, the duck's liver and heart, a quarter of a pound of minced calf's liver-fat, two handfuls of grated bread-crumbs, two eggs, some parsley minced up with a suggestion of garlic and a little onion, minced and fried in butter. Mince all these ingredients up together. Fill the duck up with this stuffing, sew it up, wrap it up in a napkin, tying the ends together, plunge it into its native element, boiling, and let it cook for an hour or an hour and a quarter, boiling hard all the time. When the water has run off (as it is proverbial it will do), serve it with a piquant sauce, and agree with me that Toulouse was not built in vain." **ROUEN DUCK**—When full grown will often surpass the Aylesbury in weight, but it does not come so early to perfection, nor is its flesh so delicate as a duckling. But as an autumnal duck it has no fellow. When fully grown it should be hung till tender, and then dressed as a wild duck and served with port-wine sauce or with the *bigarrade* or Seville orange sauce. **SAUTE DE CANETON AUX MORILLES**—The ducklings cut up as for a stew, the legs with 2 onions stewed gently, the breast pieces added and cooking continued, some morel-mushrooms added, 1 ladle meat gravy and some glaze; the onions taken out and parsley and lemon added. **CANARD A LA PUREE VERTE**—Duck cut up and stewed in broth with little garlic, onions, thyme, basil, parsley, bay leaf, salt, pepper; pint of green peas boiled and passed through a sieve, duck liquor also drained and added to the purée of peas, reduced or thickened with butter and starch, poured over the pieces of duck. **BRAISED DUCK**—Ducks fried in a pan with lard until the outside is brown; taken up and flour stirred in the pan and broth or water to make thin gravy, vegetables, herbs and seasonings added, ducks put in and simmered in the gravy 2 hours. **SAVORY DUCK**—Duck cut up, bacon and butter fried together and flour added, broth to make thin gravy, onion, herbs and seasonings. Pieces of duck fried in butter separately, then put into the gravy and stewed an hour; gravy strained; served with peas. **CANARD A L'ITALIENNE**—Stuffed with liver and bacon, mixed herbs, truffles cut into dice, all thickened with yolks, roasted, served with Italian sauce. **FILLETED DUCK**—A duck roasted  $\frac{1}{2}$  hour, the meat cut from the breast in long, neat slices, laid in a bright saucpan with brown gravy, highly seasoned, and 1 glass port; simmered gently 15 minutes; served on a border of mashed potatoes, with peas in center and gravy over the duck. **STEWED DUCK AND TURNIPS**—Whole duck browned in butter, cut turnips fried in same butter; thin sauce made in the pan with herbs and seasonings, duck simmered in till tender; served with the turnips around and gravy strained over. **DUCKLINGS WITH TOMATO SAUCE**—Young ducks filled with bread stuffing, placed in a

## DUC

baking pan with plenty of strained tomatoes, pepper, salt, minced onion and butter, cooked quickly in oven hot enough to brown them; sauce rubbed through a sieve, made hot again, served with the ducks. STEWED DUCKS AND OLIVES—The duck browned in butter, gravy made in the pan with herbs and seasonings, duck simmered in it till tender, gravy strained and stoned olives added. SALMI OF DUCK—Roast duck and giblet sauce; the duck cut up after roasting and simmered in the gravy with the giblets and a glass of wine and the juice of 1 lemon; garnished with *croutons*. GARNISH FOR DUCKLING—The common vegetable garnish for duckling is green peas or sometimes cresses; but try also cooked endive or celery, turnips browned in butter, and almost any kind of salad. ROAST DUCK—"The great secret in cooking them successfully lies in the basting, which should be very frequent and thorough. Fill the carcass with stuffing; secure the legs to the sides, so that the breast may plump up well; dredge it lightly with flour, and baste it continuously from the time it begins to cook. Just before it is done (a good-sized duck will take from three quarters of an hour to an hour) dredge it again lightly with flour, as it will then froth up and look plump; have a good brown gravy ready to serve with it, but do not pour it over the duck." CANARDS SAUVAGES EN SALMIS—Wild ducks cut up in salmis sauce. CANARDS SAUVAGES A LA BIGARADE—Cut up in orange sauce. FILETS DE CANETONS SAUVAGES A LA SYRIENNE—Breasts of wild ducks with olives in brown sauce; served with alternate fried *croutons*, spread with a paste of the duck livers and butter. SARCELLES A LA PUREE DE CHAMPIGNONS—Teal cut in joints; braised; served with a purée of mushrooms. TURBAN DE FILETS DE SARCELLES A LA TOULOUSE—Breasts of teal in a circle with fumet of game sauce, pickled mushrooms, etc. MALLARD DUCKS A LA PROVENÇALE—Stuffed, roasted; served with their own gravy and shallot sauce. MALLARD DUCKS A L'AMERICAINE—The ducks roasted about 35 minutes; carved; best pieces kept warm; sauce made of the carcasses with herbs and seasonings; port wine and currant jelly added; poured over the pieces of ducks. ROAST DUCK, APPLE SAUCE—Tame ducks plain roasted; apple sauce served with them when carved. DUCK PIE—Cold raised pie, made by lining a raised-pie case or mould with short paste, filled with sausage meat and boned ducks; baked 2 hours. DUCK IN JELLY—Jelly made of calves' feet, boned ducks simmered in it until tender; made up in decorated mould lined with jelly and filled in with duck and jelly; cold like a galantine. RED-HEAD DUCK—Cooked like *Canvas-back*, which see. "Should you wish to eat a wild duck in perfection, proceed in the following manner: Having roasted the bird for about twenty-five minutes before a brisk fire, let it be sent to table with a rich gravy. A spirit-lamp supporting a deep silver dish should be placed before the carver. Pour in this dish three glasses of port wine, a good pinch of cayenne

## EEL

pepper, a sprinkle of salt, the juice of a lemon, and some of the gravy. The duck having been carved, the pieces are rolled in the boiling preparation and handed around in the hot dish to the guests."

DUMPLINGS—Balls of flour-dough; sometimes having fruit inclosed; boiled or baked. EGG DUMPLINGS—Soft dough as if for fritters dropped into boiling water or soup; to be eaten with meat or with sweet sauce. GERMAN DUMPLINGS—*Dampfnudeln*; pieces of light-bread dough dropped into boiling water, or cooked by steaming; eaten with soup, meat stews, or with fruit sauce. SUET DUMPLINGS—One pound flour,  $\frac{3}{4}$  lb. suet, salt; mixed into soft dough, tied in a bag, or dropped in water; cooked 2 hours.

DUNDEE CAKE—Good, plain fruit cake; made of 1 lb. each sugar, butter and eggs;  $1\frac{1}{2}$  lbs. flour;  $\frac{1}{2}$  lb. each citron, sultanas and stoned raisins; 1 gill brandy. To be true to the name must be in shallow pans, with caraway comfits and sugar on the surface.

D'UXELLES SAUCE—(1)—Made of 1 pt. veloute, glass of white wine, and beef extract; mushrooms, red tongue and parsley chopped fine and mixed in. (2)—White sauce with chopped ham, mushrooms, parsley, etc.; used in a thick state for coating cutlets, etc., before breading them to fry. D'Uxelles was the name of a French general.

## E.

EAU (Fr.)—Water. EAU DE VIE—Brandy. GLACE EAU DE FRAISES—Strawberry water ice.

EAU DE BARBADES—We had intended to give Martin's views on wines, (1739) including that of Nuits, "for the health," and that of Hai, as the best in Champagne; whence also came a Tokai, and a wonderful Bon-chretien pear. Liqueurs, too, would claim a few words, were it only to wonder whether Eau de Barbades could be anything else but Jamaica rum; Esquibar was clearly usquebaugh; and eau-de-vie d'Irlande smells of potheen a mile off.

ECARLATE (Fr.)—Scarlet, with red tongue, or corned beef.

ECHINEE (Fr.)—Chine. ECHINEE DE PORC ROTIE—Roast chine of pork.

ECCLES CAKES—Baker's shop pastry; rounds of puff short paste containing a filling of currants and brown sugar, flavored; sugar on top.

ECOSSAISE (a l')—In Scottish style.

EELS—Found in sluggish streams and mill ponds; plentiful in countries where the farms are divided by dykes or ditches and where ponds abound; but not in general use in this country. LINLITHGOW EELS—The celebrated "Linlithgow" recipe for cooking eels: Kill, clean, and rub them well with salt, slit them up belly-way, and remove the bone. Next, wash well and dry, then cut into 4-inch lengths; dredge well with flour. Dip the pieces in a thickish batter made of melted butter and yolk of egg, seasoned to taste with salt, cayenne, and a

## EEL

mince of parsley, sage and shallot. Roll in bread-crumbs twice over, then broil on a clear but slow fire till well done. Serve with either melted butter or anchovy sauce. **SKINNING EELS**—The great culinary artist, Ude, gives the following directions for the skinning of eels: "Take some live ones, throw them into the fire, and, as they are twisting and turning about on all sides, lay hold of them with a towel in your hand, and skin them." That mode certainly appears to us singularly cruel. Dr. Kitchener endeavored to have eels killed in as humane a manner as possible. "With a sharp-pointed skewer," he says, "pierce the spinal marrow through the back part of the skull; life will instantly cease." Another cook says: "Dip all over for an instant in boiling water; then skin." Another says: "Stun them with a blow upon the head, cut an incision around the neck, catch the edge of the skin, holding by a cloth, and pull it off." **SPITCHCOCKED EELS**—Large eels split, bone taken out, cut in lengths, seasoned, breaded, fried, sauce, or butter and lemon. **STEWED EELS**—For ordinary tables they are not skinned. "The present consumption of eels in London aggregate about 1,650 tons a year, value £130,000. It is estimated that some 24,000 regular customers contract for their supplies of this fish, and sell them again retail. The London stewed eel trade is in fact a considerable one, and the enterprising, though for the most part humble, caterers engaged in it render essential service to the poorer classes by supplying at all hours and at very low figures this highly nutritious food in a cooked condition. Some of the large stewed eel vendors use a ton of fish weekly. The great bulk of the eels consumed in London, whether in the form of the aristocratic eel *a la Tartare*, and *a la Poulette*, or the more plebeian eel soup and eel pies, comes either from the Fens or from Holland and Germany." **ANGUILLES A LA BROCHE**—Roasted eels. A large eel, the head left on, skinned, the back larded with small strips pork, steeped in seasoned marinade 3 hours, skewered into oval ring shape, roasted or baked, shallot sauce. **ANGUILLES AU SOLEIL**—Cut in large pieces, first boiled in wine, water and vegetables, then breaded and fried. **ANGUILLES EN RAGOUT**—Stewed and served in the sauce with wine. **ANGUILLES A LA MINUTE**—In pieces, boiled in salted water, served with maitre d' hotel sauce and potatoes. **ANGUILLES A LA POULETTE**—Cut in pieces, stewed with wine, broth, mushrooms, shallots, mace, salt, cayenne; liquor strained and made yellow with yolks; lemon juice added. **ANGUILLES EN MATELOTE**—Stewed with oysters, onions, parsley, mushrooms etc. **ANGUILLES A LA ORLY**—Split, boned, cut in long pieces, dipped in batter, fried; with rings of dry-fried onions. **ANGUILLES A L' ECOSSAISE**—In Scottish style; cut up and salted for an hour; washed, stewed in broth with vegetables and herbs; liquor strained, thickened with flour; squares of buttered toast to serve it on. **ANGUILLES A L' ANGLAISE**—Thin buttered sauce made with herbs, little lemon

## EGG

peel, salt; cut up eels stewed in it; parsley and lemon. **STEWED EELS**—Cut in lengths, stewed in water with salt and pepper, thickened with flour; chopped parsley added at serving. **EEL PIE**—Pieces rolled in flour which is seasoned, placed in a dish lined with paste, broth poured in; covered with top-crust, baked an hour. **ANGUILLES A LA TARTARE**—Eels full length skewered and tied into ring-shape, parboiled in seasoned broth, taken up, double breaded, fried in wire basket, served with tartare sauce in center of the ring; garnished. **ANGUILLES A LA CENDRE**—Eels cooked in the coals. Cleaned, coiled up, seasoned, wrapped in buttered paper, covered with embers and ashes in the open fire-place; paper removed, served with butter and bread. **EEL SOUP**—Made of eel partly fried in butter, with broth, wine, tomatoes, flour, etc.; eels and toast served in it. **EEL A L' IZAAK WALTON**—In spite of the prejudice against eels, they make an excellent pie, and were for centuries thought fit for royal banquets and monastic tables. If eels went into monastic refectories, they have a brevet for any other dining-room. Eels are equally good fried, stewed, or roasted. For a recipe for the latter we refer our readers to Izaak Walton's charming book; it is one he recommends by the strong statement, "that when he gets an eel dressed according to it, he wishes it were as long and as big as the eel caught in Peterborough River in 1667—a yard and three-quarters long." **TURBAN DE FILETS D' ANGUILLES, SAUCE PERIGUEUX**—Eels split and boned, cut into 4 inch lengths, flattened; a turban mould or deep cake mould lined with fish forcemeat containing truffles and mushrooms; fillets put in upright-way, center filled with forcemeat, steamed an hour, turned out; sauce of fried truffles in Bechamel, truffles garnish and prawns.

**EEL-POUT**—Cooked same as eels.

**EGGS**—"Though many, I own, are the evils they've brought us, And royalty's here on her very last legs, Yet who can help loving the nation that taught us Six hundred and eighty-five ways to dress eggs!" That is what Tom Moore had to say in favor of France, and it shows that the invention of new ways of cooking eggs is a very old pastime. Some years ago a book was advertised in this country which gave recipes for 700 ways of cooking eggs and fish; perhaps, however, it was rather too much of a good thing, for it has dropped out of sight. That it was an old pursuit even in Moore's day is apparent from a review of a once famous cookery book in three volumes that was published in 1739, in Paris, of course, by one Marin, the *Carême* of his day, the leader in a new school of cookery. "Marin was very strong on eggs—after meat, he averred, the most nourishing, assimilable and healthy of foods; the poor shared them with the rich, and the whole with the invalid. He therefore gave endless ways of cooking them, and an infinity of omelettes. He even printed the menus of a dinner for twelve and a supper for seven, each of four

## EGG

courses, and all wholly and solely of eggs. The dishes included skewered eggs, meringues of eggs, eggs as sole and as whiting, a hot pie of fresh eggs, which would lead one to fear they were not all so, but rather suited to the palate of the city dame in the old play, who liked the whites 'of a delicate blue.' She ought to have married the man who preferred his potatoes 'with a bone in them.' We light also upon eggs 'à la grand'mère,' the mode of preparing which is not given—perhaps, it might be surmised, for obvious reasons; but no, all preconceived notions on the subject must be abandoned, because the dish figures as a hot entremets. The dinner contained twenty and the supper nineteen dishes of eggs, and the effect ought to have been to excite the state of mind shown by the parson in old Joe, who dined with the miserly squire who had a warren, and whose grace after meat ran:

Of rabbits roast and rabbits boiled,  
Of rabbits cooked and rabbits spoiled,  
Of rabbits young and rabbits old,  
Of rabbits hot and rabbits cold,  
Of rabbits tender and rabbits tough,  
The Lord be praised we've had enough."

ŒUFS A LA RELIGIEUSE—Convent eggs; hard-boiled eggs cut in slices while they are hot, and covered with softened butter mixed with grated cheese and pepper. ŒUFS A L'APPETISSANTE—Hard-boiled eggs cut in halves, the yolks taken out, pounded with anchovies and butter, returned to the whites, smoothed over, decorated. EGGS AU BAIN-MARIE—"Experiment by stewing all kinds of animal food in the *bain-marie*, and comparing the result with stewing in boiling or simmering water. A very simple and instructive experiment may be made by cooking an egg in a glue-pot or milk-scald. Allow 6 or 7 minutes, instead of 3½. A hen's egg cooked thus will be as tender and delicate as a plover's egg cooked as usual in boiling water. Besides this tenderness there is another practical advantage. A minute or two more or less, or even three or four minutes more, will not spoil the egg. The effect of overdoing an egg at the proper cooking temperature, 160 to 180 degrees, is rather curious. The white remains tender, but the yolk hardens, becomes harder than the white. I discovered this in making experiments on eggs. I found that the yolk of a hen's egg coagulates at a lower temperature than the white. In ordinary cooking this does not show itself, as the heat is not allowed sufficient time to penetrate the yolk. When I warmed an egg throughout to about 140 degrees, and kept it at that temperature during several hours, the yolk became quite hard, while the white was only jellied." ROCK WORK, ŒUFS A LA NIEGE—Snow eggs with custard; made by separating eggs, making a yellow custard with the yolks, whipping the whites firm with little sugar, and poaching by dropping spoonfuls in boiling milk, the poached white "rock work" being built up in the bowl of custard. SAVORY EGGS—Eggs beaten in a bowl with little chopped green thyme, salt, pepper,

## EGG

scrambled in plenty of butter. EGGS A L'ANNECY—Hard-boiled eggs cut in halves, yolks in a saucepan mixed with mushrooms, parsley, salt, pepper, onions and butter, raw eggs to bind, put back in whites. MAYONNAISE EGGS—Hard-boiled eggs, ends cut off, yolk extracted, pounded with oil, vinegar, mustard, salt, cayenne, put back, eggs set on end in dish; garnished with salad. EGG SHELLS—"The peripatetic 'shows,' which move from fair to fair in the country, often include a shooting-gallery, the targets whereof are egg-shells. Inquiry has elicited the fact that these are collected in thousands from hotels and restaurants, the *chefs* of which establishments have them blown instead of breaking them in the ordinary way." SCRAMBLED EGGS WITH ASPARAGUS—Tips of asparagus cooked separately and buttered are mixed in scrambled eggs when just done. EGGS FOR THE BRAVE—"No honest appetite ever yet rejected an egg in some guise. It is nutriment in the most portable form and in the most concentrated shape. After the victory of Muhldorf, when the Kaiser Ludwig sat at a meal with his burgrafs and great captains, he determined on a piece of luxury—'one egg to every man, and two to the excellently valiant Schwepperman'." EGGS WITH HAM-TOAST—Potted ham with butter spread on toast; a poached egg on each slice. EGG PYRAMIDS—The yolks and whites separated, each yolk dropped in a very small metal shell or butter-chip previously buttered; the whites whipped quite firm, a spoonful placed on each yolk, shaped up to a cone; baked in slack oven. EGG ZEPHYRS—Little steamed puddings of eggs and butter; made by beating 6 oz. melted butter into 6 eggs and 2 oz. sugar; flavor; sauce. EGG SOUFFLES A LA REINE—Whipped whites and sugar in small custard cups, steamed, the center scooped out, filled with rich yellow custard; macaroon-crumbs on top. EGG PANCAKES—Made of eggs and butter and a very little cream; 6 eggs to 4 oz. butter, 1 oz. cream, salt; cooked as a pancake; lemon-juice and sugar over. EGGS AND BACON—Sir Kenelm Digby, in his *Closet of Cookery* (1669), says: "A couple of poached eggs, with a few callops of pure bacon, are not bad for breakfast, or to begin a meal." EGG SANDWICH—Hard-boiled eggs pounded white and yolk together in a mortar with butter, salt, pepper, cayenne; spread on thin buttered bread. ŒUFS MOLLETS A LA BOUCHERE—Soft eggs with meat. Half pound each of bacon, tenderloin beef and small button onions; the meat cut to the size of the onions; all fried in butter; brown sauce added, herbs, seasonings; ½ lb. mushrooms fried; poached eggs served on top. DEVILLED EGGS—Hard-boiled eggs cut in halves; the yolks pounded with potted (devilled) ham, pepper, mustard and oil, or butter, and lemon juice; put back in whites; served with salad. EMPERORS—Sliced hard eggs on rounds of bread; a split sardine coiled on the egg; chopped egg in center of sardine; stoned olive on top. EGG SOUP—Yolks in a soup tureen; boiling clear soup beaten in; vermicelli, or



## EGG

rice, separately cooked, mixed in. **ŒUFS A L'AURORE**—Hard-boiled eggs chopped in cream sauce, to be thick enough to keep form on the dish; part of the yolks reserved and rubbed through seive to yellow over the surface; made hot to serve. **ORLEANS CLUB EGGS**—"An established luncheon dish, young in fame, but firmly established and approved since the first trial, is a dish of plattered eggs whose golden yolks are set in a red-brown semi-fluid of tomato purée and shredded anchovies." **EGG SALAD**—Sliced eggs, chopped parsley, salt, pepper, vinegar, oil, or with salad dressing. **ŒUFS A LA TRIPE**—Sliced eggs in onion-cream sauce. **ŒUFS FARCIS**—Stuffed eggs. Hard-boiled, cut in halves, yolks mixed with grated ham and parsley; butter over in the oven; served on *croutons*. **EGG SAUSAGES**—Sausage skins are filled with the same mixture as for "omelet with fine herbs," in a raw state, filled with a funnel, divided into sausage lengths with twine, carefully poached without boiling; skin taken off when cold, warmed in butter, served ornamentally with a vegetable. **ŒUFS A L'ARLEQUIN**—Many-colored. Poached eggs on toast, sprinkled with green parsley, red ham, black truffles, all chopped; brown sauce around in the dish. **ŒUFS A LA DUXELLES**—Poached eggs cut when cold like biscuits with a round cutter, coated with Duxelles sauce, breaded, egged, and breaded again, fried. **EGGS STUFFED WITH NOUILLES AND HAM**—Hard-boiled split, yolks removed, whites filled with mixture of fine-cut nouilles mixed with minced ham; cooked yolks like vermicelli through a seive on top. **EGG ROLLS**—Minced eggs and smoked haddock or other fish, mixed with mayonnaise, placed inside some small hollowed baker's rolls or finger rolls; served with cheese after dinner and for lunch. **SPANISH EGGS**—Poached eggs on a dish of boiled rice plainly seasoned with salt and butter; stick cinnamon boiled in the rice. **CURRIED EGGS**—Quartered eggs in curry sauce, made by slicing an apple and onion and frying them in butter, curry powder, flour and water added to make the sauce; hard eggs put in, and served with a border of rice when hot enough. **ŒUFS BROUILLES AUX POINTES D'ASPERGES**—Scrambled eggs with asparagus tips. **ŒUFS BROUILLES AUX TRUFFES**—Scrambled eggs with truffles cut in dice, warmed in butter separately, then mixed in. **ŒUFS BROUILLES A L'INDIENNE**—Scrambled eggs with butter, onion, salt, pepper, cayenne, curry powder and lemon juice. **ŒUFS AU BEURRE NOIR**—Eggs dropped into butter which froths and turns brown while frying; sprinkled with chili and tarragon vinegar; served on toast. **ŒUFS Poches au Jus**—Poached eggs in brown gravy; dish made memorable by Brillat-Savarin, who liked them cooked under roasting meat. **ŒUFS Poches au Jambon**—Poached eggs on oval slices of broiled ham, with a peppery sauce. **ŒUFS AU KARI**—Eggs with curry; poached in an onion-cream sauce containing curry powder enough to make it yellow. **ŒUFS EN CANAPES**—

## EGG

Hard-boiled, the yolks seasoned, made green with chopped parsley, put back in the whites; served on toast. **ŒUFS AU MIRROIR**—Eggs like a small hand-mirror; shirred eggs. **SHIRRED EGGS**—American name; eggs dropped in a rather deep oval dish well spread with soft butter, and soft-cooked either in the oven or on top of range. **ŒUFS A LA BONNE FEMME**—Eggs a good woman's way; baked with chopped onions and vinegar. **ŒUFS AU SOLEIL**—Eggs like the sun; same as *Duxelles*. **ŒUFS A LA PROVENÇALE**—Cooked in small moulds with chopped onions, brown sauce, etc. **ŒUFS A L'AVIGNONNAISE**—Hard-boiled, divided across; forcemeat made of the yolks, bread, anchovy, salt, pepper, nutmeg, white sauce; a built-up dish made of the whites, and forcemeat, crumbs, cheese and butter over; baked. **ŒUFS EN CAISSE**—Hard-boiled, sliced; in buttered cases lined with bread crumbs, with cheese in white sauce between the slices; crumbs on top; lightly baked. **BAKED EGGS**—Hard-boiled, sliced in dish with tomato sauce and grated cheese; crumbs over; baked. **ŒUFS A LA BECHAMEL**—Hard-boiled, split lengthwise, in Béchamel sauce; crumbs over; browned in the oven. **ŒUFS AU VELOUTE**—Slices in white sauce with butter and pastry. **FRICASSEED EGGS**—Same as eggs *a la tripe*. **ŒUFS AU GRATIN**—Sliced in white sauce; covered with cheese and crumbs; browned. **EGGS A LA CREOLE**—Eggs dropped singly into hot oil and fried in round shape; served with *croutons* and brown tomato sauce. **ŒUFS A LA COMTESSE**—Eggs boiled medium, shelled, dipped whole in thick yellow sauce, breaded, egged and breaded; fried, served on napkin with fried parsley. **ŒUFS AUX PISTACHES**—A sweet dish; a kind of egg-pudding; made of 4 oz. butter, 1 oz. flour, ½ pt. cream, in a saucepan; lemon rind, 1 oz. sugar, 8 eggs, 5 oz. pistachio nuts pounded; stirred over fire till like thick scrambled eggs; smoothed over in a dish; sugared; glazed in quick oven. **EGG CROQUETTES**—Hard-boiled and minced in cream sauce thick enough to set when cold; seasoned sufficiently for the eggs; some parsley and chives; rolled when cold; breaded; fried. **POACHED EGGS WITH SPINACH**—Spinach boiled green, drained and buttered; a neatly poached egg on top. **ŒUFS EN VOL-AU-VENT**—Puff-paste shell filled with slices of egg in rich cream sauce. **EGG PATTIES**—Small patty cases of puff paste (*petits vols-au-vents*), the inside remainder of paste removed after baking; a raw egg dropped in; slack-baked again to set the egg; served hot with rich cream sauce and lemon. **ŒUFS A LA POLONAISE**—Hard-boiled, yolks mixed with fried shallots and tomato; whites re-filled; baked; fried crumbs over. **EGG BLANQUETTE**—Yolks and whites steamed in separate moulds as if for soup, cut in lozenges with tongue, truffles and mushrooms; all mixed in rich cream sauce, colored pale-yellow with raw yolks; served in border of fried shapes of bread. **CROUSTADES AUX ŒUFS**—Cassolettes or fried-bread cases filled with the *blanquette* preparation. **ŒUFS A LA**

## EGG

COQUE — Plain boiled eggs. EGG MEDALLIONS A LA Russe—Hard-boiled slices on rounds of fried bread, with top dressing of caviare. RISSOLES D'ŒUFS—Hard-boiled, cut in dice, mixed in thick cream sauce with raw yolks and minced fried onions, etc., stirred over the fire same as croquette mixture. Pieces size of corks rolled up in paste and fried. ŒUFS A LA REGENCE—Hard-boiled, yolk extracted from aperture in end, filled with soft chicken forcemeat, poached, dished on end with white Italian sauce. ŒUFS A LA CARDINAL—Slices of hard-boiled eggs, yolks pounded to paste with butter, rings of white filled with red forcemeat of salmon and lobster; poached in baking pan; yolk-purée warmed in center of dish; rings around; pink cardinal sauce over. EGG PIE A LA MARSEILLAISE—Onions and truffles sliced and fried with slight flavor of garlic, drained, sliced hard-boiled eggs added in seasoned Béchamel; bottom crust of short paste; top covered with mashed potato; baked brown. ŒUFS A LA MUSCOVITE—Hard eggs scooped out and stuffed with Russian salad of cooked vegetables finely cut in tartare sauce; cold on bed of lettuce. ŒUFS A L'OSEILLE—Sorrel and eggs; the sorrel cooked like spinach with butter; hard eggs in quarters on top. PICKLED EGGS—Hard-boiled eggs without shells in a jar; boiling, spiced vinegar with few onions poured over; ready for use in 3 days. BEIGNETS D'ŒUFS—Egg fritters; soft poached eggs seasoned, cut round, inclosed in thin puff-paste, breaded and fried. EGG KROMESKIES—Soft poached eggs seasoned, dipped in batter, and fried. DAISY EGGS—Rings of fried bread just large enough inside to hold one egg; set on buttered pan, an egg dropped in; baked to set; seasoned, buttered; parsley dust sprinkled over. FRIED EGGS A LA VIENNOISE—Poached eggs trimmed round, dried on cloth, rolled in flour, and fried; used to garnish dishes, and for spinach, sorrel, etc. ŒUFS SUR LE PLAT—Eggs on the dish; shirred eggs with thick cream cooked on top, as well as butter in the dish. EGG PUDDING A LA MILANAISE—Sliced hard eggs in a pudding dish, a custard with salt and pepper poured over, grated cheese on top; baked till set. PAUPIETTES OF EGGS—Minced hard eggs highly seasoned, portions rolled in very thin pancakes, dipped in batter, and fried; they are like Frankfurt sausages in shape. ENGLISH EGG PUDDINGS—Batter puddings made with much eggs and little flour, some cream, the whites beaten light and stirred in; boiled in bowls or in a floured pudding-bag; served as soon as taken up; eaten with an acid sauce, like raspberry vinegar, or lemon juice and sugar. ŒUFS A LA MATELOTE—Poached eggs with matelote sauce. NEST OF EGGS—Nouilles paste (noodles) shred like straws and fried; used as a border to make a nest in a dish, and stuffed eggs with sauce served in it. ŒUFS A LA SUISSE—(1) Shirred eggs, having a lining of shaved cheese upon the butter in the dish, the eggs dropped in raw, cream on top, grated cheese on surface; baked. SWISS EGGS—(2) An omelet

## EGG

or fondue; 6 eggs, 2 oz. each grated cheese and butter, salt, pepper, parsley, tarragon, chives; fried like pancake or omelet or in oven. POACHED EGGS A LA Russe—Neatly poached eggs on toast, with a thin white mushroom sauce poured over all. EGGS ON HORSEBACK—A couple of travelers stopping at the Hotel Française, in the city of Cordova, the capital of the Argentine Confederation, were surprised and amused by noticing on the bill of fare "eggs on horseback." Determined to know what it meant they called for the equestrian dish, when a steak "topped" with two eggs was placed on the table. ONE EGG FOR TEN MEN—One ostrich egg for ten guests is the pattern at the California ostrich farm. "One, two, three, four, five, six, seven, eight, nine, ten," said Dwight Whiting, counting the guests he had invited to spend the day at the ostrich farm with him. "I guess one egg will be enough," and having given utterance to this expression he wended his way to the paddock and soon brought to the house an ostrich egg. For a whole hour it was boiled, and though there was then some misgivings as to its being cooked, the shell was broken, for curiosity could no longer be restrained, and a three-pound hard-boiled egg laid upon the plate. But aside from its size there was nothing peculiar about it. YOLKS OF EGGS—A correspondent asks: "Can you tell me what use to make of surplus yolks of eggs? You do not mention but one kind of cake made with yolks. I am employed in a fine bakery or confectionery and sometimes have several quarts of yolks left over in a week and have to throw them away spoiled." Answer: If you were doing hotel work you would find, on the contrary, the whites would be left over, there being so many more uses for the yolks. The yolk contains all the richness of the egg, and gives color, flavor and smoothness to puddings, creams, custards, and sweet sauces, better alone than with the whites mixed in. We use the yolks also in fish sauces, salad dressings, in potato and other croquettes, also minced for an ornamental garnish, mixed with flour for "noodles," and with batter for another kind of soup, also thicken soups with them, instead of flour and starch, and steam yolks in bulk like a cake, then cut up and use them as we would chicken meat for patties. We rub cooked yolks through a sieve, making a sort of vermicelli, to serve with some dish, and we drop them whole, also, in soup to substitute turtle eggs. We cut them up and mix with chicken meat, mushrooms and sauce to fill the shells of fried bread with, and if there are any raw yolks left over after that, we mix them in the waffle batter. In a good bakery you will find nearly as many uses for this, the best part of the egg, no matter how many may be left over from your using the whites in meringues, macaroons, icing, etc., for the yolks may be mixed with water and used the same as whole eggs. Take a pint measure about two-thirds full of yolks, fill it up with water and you have a pint of eggs, which is a pound, or equal to 10 eggs, and

## EGG

the mixture of yolks and water can be used in making almost any sort of cakes, the only difference observable being that they are yellower and richer than if whole eggs are employed. In this way you can utilize the yolks in all sorts of small cakes, in French coffee cakes, buns, rusks, brioches, and in the sorts of sponge cakes and jelly rolls which are made light with powder instead of whipped whites. If you make ice creams, they alone—that is the fancy kinds—should use up all of that material you can have to spare, and another good purpose to put surplus egg yolks to, is to mix them with lemon or orange syrup and a little butter, and stir the mixture over the fire until it thickens, making lemon or orange butter or cheese-cake mixture. **ŒUFS EN ASPIC**—Sliced hard-boiled eggs ornamentally set in a mould of aspic jelly, turned out on a border of salad. **ŒUFS AU TOMATE**—Hard-boiled, the whites cut in strips in tomato sauce, in a dish with border of fried bread, the yolks chopped and spread on top. **GOLDEN EGGS**—Hard-boiled, shelled, breaded and fried whole. **SUNSHINY EGGS**—Eggs fried on one side, with tomato sauce poured over in the dish. **EGG OMELETS**—*See omelets.* **PLOVER'S EGGS**—*See plover.* **AN EPICURE ON EGGS**—“I agree with Falstaff, in his contempt for the prevalent absurdity of eating eggs, eggs, eggs at breakfast. ‘No pullet sperin in my brewage,’ say I. I prefer chicken to the egg, and the hen, when she is really a fine bird and well roasted or grilled, to the chicken.”

**EGG FLIP**—*See hot brews.* “They can also be drunk in the shape of that ‘egg flip,’ which sustains the oratorical efforts of modern statesmen.”

**EGG-NOGG** and **ICED EGG-NOGG** — *See drinks.*

**EGG KISSES**—Meringues; baked, white of egg and sugar.

**EGG SAUCE**—Butter sauce with an admixture of chopped eggs.

**EGG REMEDIES**—The white is the most efficacious of remedies for burns, and the oil extractable from the yolks is regarded by the Russians as an almost miraculous saive for cuts, bruises and scratches. A raw egg, swallowed in the throat, and the white of two eggs will render the deadly corrosive sublimate as harmless as a dose of calomel.

**EGG OIL**—Is extracted from the yolks by the family doctors in the southern states, by slowly frying, stirring and almost burning a mass of yolks in a frying pan without any additions.

**EGGS IN THE ARTS**—In France alone the wine clarifiers use more than 80,000,000 a year, and the Alsatians consume fully 38,000,000 in calico printing and for dressing the leather used in making the finest of French kid gloves.

**EGG PRESERVATION**—Drying eggs in the form of grains of powder has proved practicable but scarcely yet commercially successful, probably

## EGG

through the fear of the public that spoiled eggs may be concealed in the preparation. The experiment can easily be tried by spreading a beaten egg upon a plate and allowing it to dry out; it will leave the plate in brittle crumbs which can then be dissolved in warm water and used. The yolk alone, if dried, cannot be dissolved afterwards unless with the aid of some chemical admixture. The white alone if dried is easily soluble, and easily kept and after keeping and dissolving in water can be beaten to froth as well as if fresh. **THE HAVANA PROCESS**—The following is the “Havana process” for keeping eggs, the formula for which has been kept a secret or sold to persons who were willing to pay \$2 for it: Take twenty-four gallons of water and put in 12 pounds of unslaked lime and four pounds of salt. Stir well several times a day and then let it stand and settle until perfectly clear. Then draw off twenty gallons of the clear lime and salt water. By putting a spigot in the barrel about four inches above the bottom you can draw off the clear water and leave the settlings. Then take five ounces of baking soda, five ounces cream tartar, five ounces saltpetre, five ounces borax and one ounce of alum; pulverise these, mix and dissolve in a gallon of boiling water, which should be poured into your twenty gallons of lime water. This will fill a whisky barrel about half full and such a barrel holds 150 doz. eggs. Let the water stand one inch above the eggs. Cover with old cloth and put a bucket of the settlings over it. As the water evaporates add more, and the eggs must be kept covered. For the ordinary purposes of home consumption the French peasantry have for ages preserved their eggs in a very simple fashion. They take a wooden case, or a large barrel, and pack them in thick layers of sawdust, fine sand, chalk, bran, cinders, or coal dust, so that they do not touch each other. In the United States we have limed eggs—that is, eggs kept in lime water—and pickled eggs—kept in strong brine—so much a matter of course that they are regular market quotations, which shows that they are the most expedient and practicable ways. The eggs are not as good as fresh and the prices are according, still they are good and sometimes form the only available supply of this most necessary article. In experiments with egg-preserved too little attention seems to be paid to the question of temperature; eggs are like meat and can be kept for an indefinite period in a cold storage chamber at about the freezing point, without regard to the packing; on the other hand any vegetable packing that may become damp around them will heat and spoil them in a few days. A farmer carried off the prize at a fair for his eggs, preserved for months by only packing in dry bran; if all had been known probably it would have been found that a cold cellar had been the real means of saving them.

**EGG PLANT**—The aubergine fruit; deep purple, almost black outside; egg-shaped, size from that of a pint cup to three times that bulk; plentiful and cheap in the markets; most at home in the

## ELD

South. EGG PLANT A LA TURQUE—*Mussaka*, I learned, otherwise *Imam-Buldi* (which in English means “the High-Priest’s Tuck-in’),) was the name of it, and the manner of its preparation the following: Cut up an egg plant (*aubergine*) into slices, salt them, strain them for a few minutes, dry them well in cloth, then fry them in butter till they are of a rich brown color. Now chop up some beef very fine, and mince it carefully with some parsley, a suggestion of onion, pepper and salt, butter, and a few fresh tomatoes thinly sliced, and stew these things together until the meat is browned. Next, arrange in a pie-dish or mould, layers of egg plant, and layers of the stew. Pour a little broth or gravy into the mould, and bake in the oven for about thirty five minutes. Turn the whole carefully out on to a dish, or, better still, serve in the pie-dish. BROILED EGG-PLANT—Small ones split in halves lengthwise, not pared, seasoned with salt, pepper, oil, broiled; served the white side up; butter sauce. AUBERGINE A LA PROVENCALE—Broiled, with anchovies, fried onions and garlic in tomato sauce. AUBERGINE FARCIES A L’ITALIENNE—Halves, not peeled, fried, inside partly taken out and mixed with chopped shallots, mushrooms, fat pork, parsley, etc., put back, crumbs on top; baked. EGG PLANT IN BATTER—Pared, sliced, dropped for a minute or two in boiling salted water, or else steeped an hour in cold salted water to extract the raw taste, dried, dipped in batter, fried like a fritter, sprinkled with salt, served as a vegetable with meat. FRIED EGG PLANT—Sliced, blanched or steeped, dried, egged, rolled in cracker crumbs, fried, sprinkled with salt. In France the aubergine or egg plant is eaten in soups and stews.

ELDERBERRY The elder grows by the side of creeks almost everywhere; the berries attain a somewhat larger size and juicier condition, however, in cool summer climates. ELDERBERRY SYRUP—The expressed juice is boiled with sugar, cloves, cinnamon and sugar, bottled and used to make hot drinks. ELDERBERRIES IN PIES—They are mixed with apples and thus give a flavor, a new fruit in effect. ELDERBERRY CATSUP—Berries with boiling vinegar, salt and spices; used for fish sauce. ELDER BRANDY—The juice with some spirits added. ELDER WINE—Boiled juice with sugar, spices and yeast, fermented, racked off and bottled. At a hotel at Hastings, Douglas Jerrold was dining with two friends, one of whom, after dinner, ordered a bottle of old port. “Waiter,” added Jerrold, with a significant twinkle of his eye, “mind now, a bottle of your *old* port, not *elder* port.” BEIGNETS DE FLEURS DE SUREAU—Fritters of sprigs of elder flowers.

ELEPHANT’S FEET—Elephant’s feet, pickled in strong toddy vinegar and cayenne pepper, are considered in Ceylon an Apician luxury. The taste is said to resemble buffalo’s hump. The native of South Africa loves nothing better than a slice of roast elephant.

## EPI

ELK—Game still found plentiful in North America; good meat but not choice game; the flesh is more like dark beef than like venison, without the good flavor of either; is best cooked in steaks; can be cooked and sauced in any of the ways suitable for beef.

EMINCE (Fr.)—Mince.

ENDIVE—Chicory; cooked as spinach; used as lettuce for salads. ENDIVE SALAD A LA FRANCAISE—The white leaves only are good. The salad bowl is rubbed with garlic and endive cut up in it; 1 teaspoon salt, little pepper, 5 tablespoons oil, 2 tablespoons vinegar. Two crusts rubbed on garlic; to be stirred about in the salad then taken out.

ENTRECOTE—Rib steak of beef. ENTRECOTE DE PORC—A pork steak or slice cut anywhere. ENTRECOTES DE BOEUF A LA BORDELAISE—Thick rib steaks; broiled, with Bordelaise sauce and beef marrow.

ENTREES—Small meats made up in various guises with sauces and garnishings, as distinguished from the principal joints and roasts.

ENTREMETS—Term rarely used. French name for made dishes of vegetables, sundry savories, puddings, creams, something less than an entree. “Another *Traite de la Cuisine* had just then been published, by one Menon it would appear, but it was a mere *rechauffe* of Massialot’s work. This long forgotten gift of the god of revelry took so well that three years later Marin, the ‘Officer,’—the cook no less—who produced it issued a sequel in three volumes, with a preface by De Querlon. The first point in the history of cookery that strikes one is that entremets were just then beginning to get confounded with hors d’œuvres, and these with entrees; the recent revolution in taste had extended even to the order of the dishes. Except in ‘repasts of ceremony,’ there were no fixed rules; and Marin, while on the subject remarked, under the head of Spring, that the sterility of that season left him no entremets but ham, or what his skill could evolve out of vegetables.”

EPAULE (Fr.)—Shoulder. EPAULED’ AGNEAU—Shoulder of lamb.

EPERLANS (Fr.)—Smelts.

EPICURE—A dainty eater; a discriminator in diet; a critic of flavors; an analyst of taste. “Mr. Lynch is an epicure, and that reminds me of a story the captain of my yacht tells. Two Englishmen were discussing the subject of eating, and one says to the other: ‘Ennery, vot is a h’epicure?’ The answer was: ‘O, a h’epicure? Why, a h’epicure is a bloke as will h’eat h’ennything.’”

EPIGRAMME—Said to be from epigast, the lower part of the breast, but here is a different explanation: “In the days when French tax-farmers were as remarkable for their ignorance as for their wealth, a gentleman observed to one of them that he had been dining with a poet who regaled him with

## EPI

en epigram. Envious and angry, the dull fellow rushed home and demanded of his cook 'how it came that no epigrams were served up at his table?' The *chef* fortunately had wit and fancy equal to the emergency, and at the next dinner he served to his employer appeared an epigram of lamb. This was well contrived. Poetical epigrams usually consist in French of alternate verses. The lamb consisted of alternate cutlets, one set of the ordinary kind, cut from the neck; the other made out of the breast of lamb—braised, boned, pressed between two dishes, and, when cold, carved into cutlet shapes decorated with asparagus points." **EPIGRAMME DE MOUTON**—The breast cooked in stock till tender, bones pulled out and reserved, meat chopped and made up as for croquettes; flat croquettes made of it, egged, breaded, bone stuck in each to imitate cutlet, fried. Regular mutton chops also prepared and one of each served to each person, with peas or asparagus. **EPIGRAMME DE VOLAILLE**—Breast of chicken neatly shaped, and flat croquettes made of the other parts, served together with sauce, etc.

**EPINARDS** (Fr.)—Spinach.

**ESCALOPES** (Fr.)—Thin slices; scallops or collops of beef, veal, mutton, pork, etc. **ESCALOPES DE RIS DE VEAU AU SUPREME**—Slices of veal sweet-breads sauté in butter; served with supreme sauce. **ESCALOPES DE DINDE EN BLANQUETTE**—Turkey breast in white cream-sauce. **ESCALOPES DE LAPE-REAU AU FUMET**—Collops or fillets of rabbits baked in rabbit essence or reduced stock of rabbit carcass.

**ESCAROLE**—Broad-leaved endive.

**ESCHALOTTE** (Fr.)—Shallot; mild kind of onion.

**ESPAGNOLE SAUCE**—A stock sauce or brown gravy kept on hand by cooks to form the basis of other sauces; made by frying together carrots, onions, veal, ham, aromatic herbs, and some spices, adding broth, wine, tomatoes, flour, butter; strained, boiled and skimmed until bright brown.

**ESTRAGON**—Tarragon; a garden herb, used to flavor vinegar and soups, sauces, etc. **ESTRAGON SAUCE**—White broth thickened, with chopped tarragon and tarragon vinegar.

**ESTURGEON** (Fr.)—Sturgeon.

**EVENTAIL AUX CERISES**—Fan-form of strips of puff-paste on a bed of marmalade and cherries.

**EXCELLENT AU CAFE**—See Ices.

**EXCELLENT PUDDING**—A boiled plum pudding goes by that name; made of 1 lb. each suet, flour, sugar, raisins, currants;  $\frac{1}{2}$  lb. bread crumbs, some citron, grated lemon-peel, nutmeg, ginger, salt, rum, 8 eggs (omitting 4 of the whites); suet and dry goods mixed; sugar, eggs and rum to moisten; boiled in a bag 6 hours.

**EXTRACT OF BEEF**—A very useful preparation for enriching consommés and gravies, and mak-

## FEC

ing soup without much previous preparation of stock. The Australian and Brazilian extracts are the likeliest to be genuine, if in original packages, for the reason that animals are killed there in some places for their hides only, there being no market for the meat other than the demand from the extract of meat manufacturers. It is put up in bladders, almost dried to solidity. That manufactured in the states can be bought reasonably in cans, but in the small pots is too expensive for most hotels and restaurants.

## F.

**FAISAN** (Fr.)—Pheasant.

**FAIRY BUTTER**—Yolk of hard-boiled eggs pounded with butter, powdered sugar and flavorings.

**FAIRY GINGERBREAD**—Cakes crisp and buttery, as thin as cards; made of 1 cup butter, 2 cups sugar, 1 cup milk, 4 cups flour, 1 tablespoon ginger; spread extremely thin on pans buttered, but cold; baked in slack oven; cut in squares while warm.

**FALERNIAN WINE**—Classical allusion often met with, having reference to famous wines of old Rome.

**FANCHONNETTES**—The common English name of the whole assortment is cheese-cake. They are patty-pan tartlets, filled with various custard mixtures, such as lemon or chocolate-pie stuff, or lemon honey, with frosting on top; should be ornamented with piping besides.

**FARCE** (Fr.)—Forcemeat; stuffing.

**FARCIE** (Fr.)—Stuffed.

**FARINA**—Pudding material made from wheat; it is like sifted corn-meal to the touch. There are two kinds, one being Graham farina, which is used principally for making mush or porridge for breakfast or supper; takes 3 oz. to a quart of water or milk; requires long cooking in a *bain-marie* or double kettle; pastry cooks let it simmer in milk for puddings at side of the range, then mix in sugar, butter and eggs, and bake. **FARINA CUSTARD PUDDING**—Made thin with farina boiled in milk, and thickened with sufficient yolks, sugar, butter, flavoring; baked; served with sauce. **BOILED FARINA PUDDING**—Made with 3 oz. in 1 qt. milk; simmered till thick, little sugar, butter, 2 yolks; served in saucers with thick lemon-syrup sauce. **CONSOMME WITH FARINA**—Soup first made clear; 1 oz. farina to each qt., washed, and simmered in it till transparent. **FARINA CUP CUSTARD**—Boiled custard, of 1 oz. to 1 qt. milk, well cooked in it, 4 yolks to each quart, sugar, flavor; made cold in ice water; served in cups. **FARINA ICE-CREAM**—Cup-custard frozen; it is also called *Frozen Farina-Pudding*.

**FAWN**—A young deer; is roasted, served with currant jelly.

**FAUSSE TORTUE** (Fr.)—Mock or false turtle.

**FECULA** (Fr.)—Potato flour, or starch.

**FECULA DE MAIS**—Corn-starch.

## FEN

**FENNEL**--A garden plant much cultivated in England, which also grows wild in Florida; esteemed as a flavoring accompaniment to boiled mackerel and salmon. It is as much a matter, of course, to boil fennel with mackerel as to serve mint with lamb and peas. The green leaves tied in bunches are used; they are of the feathery sort, somewhat resembling asparagus leaves. **FENNEL SAUCE**--Made same as parsley sauce; a spoonful of chopped fennel stirred into hot butter-sauce.

**FERMIERE** (*a la*)--Farmers's style.

**FETTICUS**--Fat hen; lamb's quarter and other names; a tall, silvery green weed, grows on rich spots of land about farm houses; excellent boiled as spinach.

**FEVES DE MARAIS**--Marsh beans; French name of the broad beans much used in England.

**FIDELINI**--One of the varieties of Italian paste, thicker than vermicelli, thinner than spaghetti; is put up in even lengths in pound boxes; used for soups and same as spaghetti. **FIDELINI A LA ROYALE**--Soup; made of  $\frac{1}{2}$  lb. fidelini, boiled in salted water, drained out, put into 5 pts. chicken broth, 6 yolks, cup of cream, seasonings, stirred up to thicken without boiling. Grated parmesan cheese served with it separately.

**FIGS**--Fresh figs are plentiful in Florida and the Gulf states, and are served as breakfast and dessert fruit with cream; are used in pies and tarts, mixed with lemon juice; are best, perhaps, in preserves with lemon peel and ginger, an article of some prominence now among southern exported products. **DRIED FIGS**--Served along with fresh fruits for dessert, also cut up and used in most respects the same as raisins in cakes and puddings. **FIG PIE**--Cut up, stewed with a cut lemon in syrup, made with either a top crust or with strips over. **FIG PUDDING A L'ITALIENNE**--Made of  $\frac{1}{2}$  lb. figs (chopped fine),  $\frac{3}{4}$  lb. breadcrumbs, 6 oz. suet, 6 oz. sugar, 2 eggs, 1 teacupful milk, nutmeg as required; boil or steam for three hours. **FIG FRITTERS**--Steamed figs and fig fritters are new dishes at some hotels and restaurants where they study gastronomic novelties. **FIG SUE**--"Fig sue is a favorite dish in Westmoreland. It is made in the following manner by the better-class people:  $\frac{1}{2}$  lb. figs (cut up small),  $\frac{1}{4}$  lb. bread, 2 oz. currants,  $\frac{1}{4}$  lb. sugar,  $\frac{1}{2}$  pt. beer. Put in a pan, simmer half an hour, serve as a pudding. There is another method, same ingredients, but with home-made beer, about a pint of strong ale being added after boiling. This is eaten out of basins like soup. Fig sue is also similarly prepared with milk in the place of beer in the rural districts, sometimes thickened with oatmeal. It is in great favor here with all classes, and is taken at dinner, tea, or at night, Good Friday being the principal day of consumption." **FIG PUDDING**--Boiled pudding, made of 4 oz. suet, 5 oz. bread-crumbs, 5 oz. figs finely minced, 3 tablespoons sugar, 2 eggs, salt; boiled in a mould 3 hours; brandy

## FIL

sauce. **FIG PASTE**--Only a name for a kind of gum drops compound, no figs about it. The original name is Turkish, not adapted to be taken along with the confection. Made of 12 lbs. sugar, 3 lbs. glucose,  $1\frac{1}{4}$  lbs. corn starch, 3 gallons water,  $\frac{1}{4}$  oz. citric acid. Water and sugar boiled, starch wetted and added, then the acid and glucose; stirred constantly and cooked until it leaves the fingers in cooling. Variously flavored, colored, cut and shaped in powdered sugar.

**FIG-PECKER**--Small bird that divides honors with the ortolan among European *bon-vivants*.

**FILBERT**--Well-known nut of the hazel-nut kind; served at dessert either with nut-crackers or, if that is not convenient, the nuts ready cracked before being served in the baskets. **FILBERT SOUP**--"I wonder whether any modern *chef* possesses a recipe for the purée of walnuts which George IV frequently devoured? The foundation was a very strong game stock made from pheasants or partridges, and the walnuts were well pounded and blended with cream. It was a fellow soup to the purée of filberts, which was the favorite dish with his majesty in autumn, and which also was made with pheasants or partridges." **FILBERT CREAMS**--Same ways as almonds. **BISQUE OF FILBERTS**--Ice cream with pounded filberts, same way as almonds. **FILBERT BUTTER**--Is a nice addition to sandwiches, or may be used as a small side-dish. To make it, pound twelve filbert kernels and three ounces of butter thoroughly in a mortar, and season with finely chopped parsley, chives, and tarragon leaves.

**FILLET**--A strip or band of meat without bone. **FILLET OF BEEF**--The tenderloin entire, also in steaks or slices (small fillets, *filets mignons*); it is the undercut of the sirloin, the long band of meat which lies between the kidney fat and the backbone, extending from the small of the back to the hip joint. **FILLET OF VEAL**--The round or fleshy part of the leg of the veal; the bone taken out it is usually larded, stuffed, coiled up and skewered to a round shape. **FILLET OF PORK OR MUTTON**--The meat of the saddle or middle of the back taken from the bone; or a strip from one side, from the shoulder blade to the hip; seldom named in the menu; used technically in cookery recipes. **FILLETS OF FOWL**--The breast in two parts, or one. There is a natural division whereby the larger part leaves the minion fillet adhering to the breast bone. In some elaborate dishes the two are used separately; usually the entire breast is meant when the fillet of fowl is named. **FILLETS OF RABBIT OR HARE**--The meaty part of the back and legs, flattened and shaped for the various purposes. **FILLETS OF SOLES**--The English flat-fish, called the sole, is especially adapted in its structure to make thin bands of fish, which lend themselves readily to the cook's purposes to roll, double over or shape variously; hence fillets of soles are named in menus ten times

## FIN

as frequently as the plain fish itself. **FILETS DE SOLES A LA CAREME**—The fillets pared and flattened, spread over with fish forcemeat containing truffles and mushrooms, doubled together, laid in order in a buttered saucepan,  $\frac{1}{2}$  bottle chablis, aromatics, set in the oven for 20 minutes. Drained, dished in circular form, with a ragout of prawns etc., in the center, and sauce made of the saucepan gravy, meat essence and tomatoes; strained. **FILLETS OF FISH**—Thin fish-steaks cut the long way; boneless sides of fish. **FILLETS OF VEGETABLES**—“In his eagerness to present some novelty he even directs how to serve a dinner *entirely in fillets*; not only are his meats cut in strips, but haricots, carrots, cucumbers, leeks, and whatever else, are all shredded to the fineness of straws; but this savors more of conjuring than of good cookery.”

**FINANCIERE GARNISH**—Consists of brown sauce with sherry, lemon, cock's combs, livers, quenelles, pieces of sweetbreads, etc. Used to garnish a dish either by filling in the center or around the cutlets, sweetbreads, birds or fillet, it gives the designation *a la Financiere*.

**FINANCIERE SAUCE**—Brown sauce made with wine, lemon, mushrooms cut small, catsup, and espagnole.

**FINE-HERBS SAUCE**—Brown sauce made of espagnole, chopped mushrooms, shallots and parsley.

**FINES HERBES (aux)**—With shallots, mushrooms and parsley scattered over or amongst. **ESCALOPES DE RIS DE VEAU AUX FINES HERBES**—Sweetbreads cut small in a baking dish with fine herbs, gravy and wine; cooked in the oven.

**FINGER BISCUITS**—Lady-fingers; Savoy-biscuits; thin sponge cakes placed together in pairs.

**FINGER ROLLS**—The Italian Grissini bread, salt sticks, soup sticks; finger shapes of crusty bread to eat with soup.

**FINNAN HADDIES**—Commercial name and trade brand of Findon haddocks; smoked haddocks, cooked by (1) broiling, previously steeped in warm water, (2) boiling a short time in a shallow pan; buttered when done; (3) baking in a little milk and butter. **SAUCE FOR "HADDIE"**—Butter, mustard and lemon juice made warm.

**FISH QUOTATIONS**—for menus: “Fish is no less important to a good dinner than soup. There is an Oriental proverb, to the effect that ‘your Arab despises fish,’ which as the Arabs dwell where fish are not, is equivalent to saying, ‘the grapes are sour.’” “St. Kevin, a religious gentleman who lived by the fish he caught in one of the Irish lakes, was subjected to a severe temptation on one of his piscatorial excursions, but whether he fell into the snare laid for him or not, I do not now remember. It seems that a belle of that ilk, named Kate, put the following leading question to him:

‘You’re a rare hand at fishing,’ says Kate.

‘It’s yourself dear, that knows how to hook ’em:

## FIS

But when you have caught ’m, agrah!  
Don’t you want a young woman to cook ’em?”

If St. Kevin said ‘No,’ he was not the Irishman I take him to have been.” “Fishes are welcome at every meal, but they are peculiarly adapted for breakfast. Not one would we banish; neither regal salmon, nor lordly turbot; voracious cod, nor delicate whiting; giant perch, nor accommodating sole; bladderless mackerel, nor musical skate; savage pike, nor lowly herring; pretentious mullet, nor common haddock—no, not even the vulgar plaice. They are delicate, they are easy of digestion, and they take kindly to any flavoring the most erratic palate may desire. Hence it is that they are so valuable at the first meal.” “In order to know what cod really is, you must eat it at Newfoundland. Herring is not worthy of the name except on the banks of Lochfyne, in Argyleshire; and the best salmon in the whole world is that of the Boyne.” “A good sea fish is spoiled with too great refinement in this matter; all it needs is a clean gridiron, or a boiling kettle, a hot plate, sweet bread and butter. If a sauce is desired, do not take anchovy because it is ‘the thing,’ but try the more homely recipe of the great Edingburgh epicures: ‘Ketchup (mushroom), mustard, cayenne, butter, amalgamated on your own plate by your own hand, each man according to his proportion.’ This is for witty paragraphers, to say something about hotel salt mackerel; the Nevada salt fish mines are still doing business: “During the sinking of large pits and wells in Nevada stratas of rock salt were cut through, in which were found imbedded perfectly preserved fish, which are doubtless thousands of years old, as the salt field occupies what was once the bottom of a large lake, and no such fish are now to be found in any of the modern Nevada lakes. The specimens are not petrified, but flesh, and all are preserved in perfect form, and after being soaked in water for two or three days can be cooked and eaten; but are not very palatable. After being exposed to the air and sun for a day or two they become as hard as wood.” A traveler, Wayett Gill, says: “I am interested in the discussion going on at home about fish as food for the brain. For years past there has been annually resident in the training institution at Raratonga from fifty to seventy natives of the various islands of the South Pacific. The most quick-witted students come from the low coral islands and have grown to manhood on a diet of fish and cocoanuts. In muscular strength, however, and in the power of endurance they are decidedly inferior to the inhabitants of volcanic islands who used a mixed diet.” **FISH STEW**—The meat being cut from the bones of any kind of fish, the bones, heads and tails are boiled in water with onion and any kind of herb or vegetable seasonings to make a fish broth or cullis; some roux of butter and flour is stirred over the fire in another sauce-pan and the fish broth strained to it, making a slightly thickened soup. The pieces of fish are stewed in this, with such additions as may be avail-

## FIS

able, shrimps, perhaps oysters, perhaps tomatoes, white wine or cider and mushrooms, or only parsley and butter, or sliced potatoes. These additions are what give the different names to the dishes. **BAKED FISH**—Perhaps the least troublesome mode of cooking fish is to bake it. Any fish in slices, or of small size, can be so served by putting it on a well-buttered dish with herbs, lemon juice, vinegar, mushrooms, a glass of white wine, a little stock, anchovy sauce, or anything else that the sense of the cook may suggest, and covering it with brown bread-crumbs or a sheet of buttered paper. A few minutes will make it ready for table, and all it wants is to be slipped on a dish and garnished. Fishes carefully stuffed and baked whole are generally nice; it is a method very well suited to fresh-water fish, and a delicious way of cooking mullet or a dish of whiting. **FISH PIES**—Cornwall and Wales are famous for their fish pies. This is by no means a despicable way of cooking fish, if they are tender and not bony. Eels, bass, all kinds of flat fish, lobsters, shrimps, and oysters are mostly used. The rule is to remove all bones, fins, etc.; and when the pie is nearly done, to uncover it partially, drain off the liquor, and add cream in its place, and then return a few minutes to the oven. Pies made of herring and pilchard have a plentiful allowance of scalded leeks in them. **FISH SAUSAGES**—An appetizing and novel form of sausage made from the best portions of the dogger-bank cod, and other white-fleshed fish, directly they are landed from the fisherman's boats. They are delicately and agreeably seasoned, and may be had either quite fresh or after having been lightly smoked. Fried, boiled, curried, or otherwise treated they afford a variety of excellent dishes. **PULLED FISH**—Cold boiled fish pulled in pieces; to 1 lb. fish  $\frac{1}{2}$  pt. cream, tablespoon mustard, 1 do. anchovy essence, 1 do. catsup, pepper, salt, butter and flour to thicken; hot in sauce-pan. **PATE DE POISSON A LA RUSSE**—A specialty at Guntor's, London. A cold raised fish pie, for balls, suppers and luncheons, made of: a raised pie case in a mould, filleted soles stewed with mushrooms, parsley, onions, wine. Fillets taken out, mushrooms, shallots, etc., chopped and mixed in Duxelles sauce. A layer of fillets soles, in the pie case, layer of compound sauce, layer of pickled lobster, layer of mayonnaise sauce, few shrimps, truffles, repeated till case is full, gelatine in the fish liquor to make jelly, poured in when nearly set; not to be baked; crust baked beforehand with filling of flour. This is a fish aspic in form of a pie. **COLD FISH CUTLETS**—Croquettes, or imitation shapes of cutlets, made of cold fish in sauce breaded and fried; served hot; sauce. **COLD FISH BEIGNETS**—Fish, butter, crumbs, seasonings, pounded to a paste; pieces breaded and rolled in grated cheese, baked in pan with little butter. **COLD FISH SCALLOPED**—Pulled flakes of fish in scallops or clam shells; mustard, butter, cayenne, lemon juice, salt, mixed, poured over fish, crumbs on top, baked. **COLD FISH SALAD**—Pieces sprinkled with lemon juice along with lettuce and salad dressing.

## FLU

**FLAGEOLETS**—Haricots flageolets; the green seed beans shelled out of string beans. They can be bought in cans same as French peas and are as green; the beans so used are of special green-seeded kinds. Used as a choice vegetable for course dinners, club dishes, etc.

**FLAMANDE** (*a la*)—In Flemish or Holland style.

**FLAN** (Fr.)—An open tart with custard on top of the fruit. **FLAN DE PEACHES**—A paste crust laid in the baking pan is covered with either preserved or thick stewed peaches or else, in the season with soft ripe peaches and cream; a 6-egg custard poured over, baked till custard is set; cut in squares when cold.

**FLEMISH SAUCE**—Butter sauce made yellow with yolks and mustard; vinegar, parsley, nutmeg, pepper.

**FLITCH OF BACON**—English name for a whole side of dry salt pork; any large piece of side meat.

**FLOAT**—An American culinary term equivalent to floating island, used to denote several nondescript trifles among the sweets. **SNOW FLOAT**—Whipped jelly served in a saucer of custard. **RASPBERRY FLOAT**—Raspberry jam mingled with whipped white of an egg or whipped cream, served by spoonfuls in a saucer of custard.

**FLOATING ISLAND**—Various cold sweets go by the name. (1)—A small sponge cake spread with jelly, floating in boiled custard. (2)—A jelly cake or sponge cake floating in a bowl of cream flavored with wine. (3)—Spoonfuls of whipped white of egg dropped on the surface of a dish of custard, baked long enough to slightly color. (4)—Spoonfuls of whipped whites, sweetened, poached in boiling milk, served in a dish of cold custard. (5)—Hollow meringues or macaroons served floating in cream flavored with wine.

**FLOUNDERS**—A common and well known flat fish found at the mouth of rivers, near the sea; good to cut across and fry; is sometimes made to represent the sole; being skinned and filleted. **FLOUNDERS, WHITE WINE SAUCE**—Two flounders skinned on the dark side, scraped on white side, stewed 20 minutes in white wine, water, butter, salt, pepper; taken up, sauce thickened with flour. **FLOUNDERS A LA JULES JANIN**—Two flounders, dark side skinned, heads removed, slit down back and bone taken out; incision filled with fish forcemeat, baked with sherry and oyster liquor, sauce made of pan liquor and espagnole with butter and lemon; garnish of oysters and mushrooms.

**FLOUR**—A barrel of good flour should make from 270 to 285 five-cent loaves. Many bakers blend four barrels, as two Minnesota springs and two Indiana winters, before they get the right alloy.

**FLUKE**—A northern sea-fish, found in Canadian markets; a flounder.



## FOI

**FOIE-GRAS**—Fat liver; especially designating the livers of fat geese; a comestible of great prominence on all sides of French cookery; but, as in the case of high-flavored cheese, herbs, spices, curry, etc., the taste for the preparations of *foies-gras* has to be acquired, and there is but a limited appreciation of it here. "The goose is a bird that, after it is dead, constantly thrusts itself on the stranger's attention in Austria. Its apparition is frequent on the tables and hotels at Vienna, and it reappears more frequently as you descend the Danube. It is the most chosen viand at Buda-Pesth. Here it achieves its apotheosis. But it is not so much to the bird itself as to that important organ, its liver, that I desire to direct attention. The local commerce in this delicacy is considerable. On certain streets the attention of the pedestrian is attracted by the counterfeit presentment of a goose, dead and cooked, beside which is a painted object so nearly like that he is aware it is the liver of the deceased bird. This sign indicates a shop whose sole business is to sell roasted goose cut in pieces, goose livers and a sort of biscuit made of chopped goose and flour. Here is a temptation to those who are fond of *pate de foie-gras*. On entering, the dealer is discovered standing behind a huge tray filled with livers arranged in rows, armed with a fork resembling Neptune's trident. He passes the trident mystically over the livers and names the prices—20 kreutzers, 25 kreutzers, 30, 40, 50 kreutzers, the latter being from giant birds and weighing nearly a pound. You take one of the smallest as a starter, and a biscuit, and, adjourning to a neighboring wine-shop, properly adjust your digestive apparatus to the unctuous viand with a 'fourth' of white Hungarian wine. No bad result follows, as with the artificially fattened livers that cost their weight in gold in America. Your digestion continues excellent. What is the effect? The next day you come back and buy a liver twice the size, take two rations of biscuit and wash the repast down with a 'half' of the same wine, and so on. As this ratio of increase cannot go on forever, you find yourself obliged to leave the town a day or two sooner than you intended, to subdue a growing appetite, taking with you in your valise a few pounds of goose livers to satisfy the pangs of hunger and solace the regret of parting, for you know, when you have left the Danube you can see this luxury no more." **PATE DE FOIE-GRAS**—Pie of fat liver. "The individual who first discovered the real use to which Dame Nature had predestined the goose—that of having its liver abnormally fattened—reaped a fortune from his penetration and his ingenuity. His name was Close, and he was *chef de cuisine* to Marshal de Coutades, Governor of Strasburg; hence the association of that town with *pate de foie-gras*. The idea occurred to him one day that he would make a pie from the livers of some extremely fat geese which were hanging in the larder; and the pie being made, the Marshal was delighted, and at once gave an order that henceforth

## FON

the dish was to be included in the daily dinner, and this was done so long as the Marshal was Governor. De Coutades, however, was displaced, and his successor was a Spartan, who believed in hard, black bread and coarse broth, and voted all luxuries as sinful. Under the altered circumstances the *chef* Close resigned. He then comforted himself by marrying a wealthy Strasburg widow, opened a pastry-cook's establishment, and made the *pate de foie-gras* his specialty. Everybody who tasted it was loud in its praise, and the lucky cook made a rapid fortune, and was, of course, the initiator of a big trade. Other makers, who followed in his wake, mixed truffles in their livers, much to the satisfaction of epicures." **PATE DE FOIE-GRAS**—Paste of fat livers. Such as comes from Strasburg in jars. It is made by cooking the fat goose or duck livers with bacon, wine and aromatics, pounding it through a seive, adding cut truffles to it, potting it like potted meats. It is used in cookery to line pies made of birds or any game, the boned birds being then placed upon it alone with mushrooms and other seasonings, and the intestines in some styles are filled in either with the same *pate de foie-gras*, or, raw *foies-gras*, or goose livers, such as the pies are made of are put in as they are, without cutting or mincing. **IMITATION PATE DE FOIE-GRAS**—Calf's liver and bacon, shallots, aromatics, wine; slowly cooked for several hours in a slack oven, pounded, rubbed through a seive. **FOIE-GRAS SANDWICHES**—"Foie-gras makes a very good sandwich for luncheon purposes, if the public could be gradually brought to like it. The principal difficulty in some of these innovations or novel business uses for well-known old culinary recipes, is to get the public to understand or have sufficient confidence to try them." **COQUILLES DE FOIE-GRAS**—Same as scalloped dishes; made by placing half a *terraine* (jar) of *foie-gras* in a saucepan with half as much cooked mushrooms or truffles; all cut in small dice; sauce added; put into silver or other scallop shells; bread crumbs on top; baked in a pan with little water under till top is browned. **ASPIC DE FOIE-GRAS**—Squares or cubes of *foie-gras* in aspic jelly. **CROUSTADES DE FOIE-GRAS**—Fried bread-shapes filled with dice-cut goose livers in rich wine gravy. **SMALL ROLLS WITH FOIE-GRAS**—Small rolls baked for the purpose, quite round, hollowed out, and *pate de foie-gras* filled in; for ball suppers and lunches.

**FOND** (Fr.)—Bottom; foot. **FONDS D'ARTICHAUTS**—Artichoke bottoms. **FOND DU LAC**—Foot of the lake.

**FONDU** (Fr.)—Melted. **BUERRE FONDU**—Melted butter.

**FONDUE** (Fr.)—A dish of cheese and eggs scrambled together with butter in a frying pan.

**FONDANT**—Cream fondant; soft, white candy, made by boiling sugar to the ball; then working it back and forth on a marble slab with a paddle until perfectly white. Used for making all the bon-bons,

## FOR

such as chocolate creams, walnut creams, date creams, etc., and, softened by heat, it is used to ice cakes, being the best icing for that purpose.

**FORCEMEAT**—The various compounds used to stuff fowls, fish, pigs, tomatoes, egg plants, lettuce, etc. Some forcemeats are composed principally of chopped veal and bacon with herbs and seasonings, some of finely pounded chicken breasts bread-crumbs, butter, yolks, etc. Fish forcemeat is pounded fish, eggs, butter, and flavorings. Forcemeat for egg plants, cucumbers and tomatoes consist of the removed interiors mixed with minced onions, bread-crumbs, suet or butter.

**FOUETTEE (Fr.)**—Whipped, whisked. **CREME FOUETTEE**—Whipped cream. **SAUCE FOUETTEE**—Pudding sauce of wine, sugar and eggs whipped to froth. **GELEE FOUETTEE**—Russian jelly, or wine jelly, whipped while cooling till white and spongy.

**FRAIS (Fr.)**—Fresh. **BEURRE FRAIS**—Fresh butter.

**FRAISES (Fr.)**—Strawberries.

**FRAMBOISES (Fr.)**—Raspberries.

**FRANCAISE (a la)**—In French style.

**FRANCATELLI, CHARLES ELME**—An English *chef*, author of an important culinary work. He was a pupil of Carême and saw that great artist deriving a large income as well as much fame from his published cook books, which were, however, all in French, and he took those books and from them and his own practical experience he deduced an Anglo-French system, becoming the interpreter of French culinary art to the English, and giving the country a new set of polished culinary terms to take the place of the old homely nomenclature of the kitchen, which had prevailed up to that time. Among the faults of his really great work may be instanced the complicated nature of its directions and the endless accessories to each principal dish, leading the mind of the would-be learner off to a bewildering number of preparatory processes and causing him to give up the attempt in despair; its studied avoidance of anything savoring of a simple explanation; its nursing of mystery and use of obscure language; its covering up of old, already well-known and popular dishes with their foreign names, as if to make them appear like new things and prevent their immediate discovery, and its inculcation of extravagance and profusion. This book seems to have passed immediately out of Francatelli's possession and became the very valuable property of the publishers, for the book was favored by the aristocracy, it complimented many of its members, and sold well. The greatest profit of all, probably, has been realized by its American re-publishers, who have advertised it frantically and reaped rich returns. This, of course, was of no benefit to either Francatelli or his family. Of Francatelli himself it is scarcely possible to find any printed particulars. He was at one time *chef* to the Reform Club, *chef* to

## FRI

the Queen, *chef* at the St. James Hotel, Piccadilly, London, manager of the Free Masons' Tavern, London. He died about 1870. A London hotel, advertising in 1886, among other attractions announced that the services of Mr. Francatelli had been secured as *chef*. A London journal, noticing the ruse, hastened to proclaim that it was a son of the great Francatelli who had been engaged. About the same time an appeal for charity appeared in the London trade papers in behalf of Francatelli's daughter, who was described as being in a very destitute condition, and the smallest contributions of those who desired to lend a helping hand would be thankfully received.

**FRANGIPANE**—Pastry cream or custard, such as is used to fill cream puffs and eclairs; made of 1 qt. milk, 6 oz. sugar, 4 oz. flour, 2 oz. butter, 6 yolks, boiled, flavored. Can be much varied, mixed with whipped cream, with browned butter, with orange or lemon pulp or syrup for cream pies, tarts, fanchonettes, cheese-cakes, with chocolate, with coffee, cocoanut, almond paste, etc. When made stiff enough and the whites whipped firm and stirred in, it is baked as soufflés of all flavors, and either in one large mould or in small soufflé cases; it puffs up in the oven, and the soufflés must be served as soon as done.

**FRANGIPANI PUDDING**—A well-made bread pudding is now called a Frangipani pudding, after a powerful Roman family, so called from their benevolent distribution of bread during a famine.

**FRAPPE (Fr.)**—Semi-frozen. (*See carafes frappées, champagne frappée.*)

**FRENCH BEANS**—English name for string or snap beans.

**FRENCH DRESSING**—Indefinite; any salad dressing; yolk of egg, oil, mustard, cayenne, salt; mixed by stirring in a soup plate or bowl.

**FRENCH SAUCE FOR OYSTERS**—A cruet sauce made of 2 minced shallots steeped in 4 table-spoons lime juice, salt and crushed pepper corns, for 6 hours; lime juice strained off and little tarragon vinegar added.

**FRENCH ROLLS**—Indefinite; any good quality hot rolls; pocket book shaped rolls, split rolls, crusty cleft rolls, or tall, close-shaped bakery rolls.

**FRENCH BREAD**—Indefinite. The bread now called French is in very long loaves of one thickness from end to end. At some Paris restaurants the bakers leave loaves daily that are from one to two yards long. The hotel method is to have special pans made of Russia iron which are 5 or 6 narrow moulds all in one piece. They are in the common eaves-trough tin spout shape, about 3 inches across and 18 inches long. The ordinary bread dough baked in these makes the favorite crusty cylinder-shaped loaf for the dinner table.

**FRIANTINE (Fr.)**—Tit-bit. **FRIANTINES AUX HUITRES**—Bouchees of oysters; small patties.

## FRI

**FRIED CAKES**—Domestic name for crullers, doughnuts or "Jersey wonders."

**FRIED PIES**—Domestic name for rissoles, rissolettes, kromeskies, or anything made of paste, folded and inclosing fruit or jelly.

**FRICASSEE**—Common name in general use for a stew without special characteristics further than the division of white fricassee or brown. Originally it meant a fry with a sauce. (*See Frogs.*)

**FRICANDEAU**—A larded cushion of veal, braised, or browned in the oven; also an imitation of the same, made of a mixture of cooked and raw meat well seasoned, made up so as to be served in broad slices. **FRICANDEAU OF STURGEON**—Pieces of sturgeon about 5 inches thick, skinned and larded with bacon; laid larded side downwards in a stewpan with bacon, and fried till the larding is brown. Taken up, put in a baking dish with mushrooms, moistened with essence of ham or brown sauce with minced ham and onions; the larded side upwards, baked for an hour.

**FRICANDELLES**—A mixture of chopped meat either cooked or raw or mixed, with some fat and bread-crumbs and an egg, seasoned, made into pats and fried.

**FRITOT (Fr.)**—The original fricassée; chicken cut into joints, floured, fried, served with cream sauce. **FRITOT DE POULET AUX TOMATES**—The chicken cut up, steeped in oil with onions, floured, fried; tomato sauce.

**FRITTO (It.)**—A fry or a fritter; same as *fritot*.

**FRITTO MISTO (It.)**—Mixed fry. (*See Italian cookery.*)

**FRITTER**—Something inclosed in a flour batter and fried by immersion in hot fat. **FRUIT FRITTERS**—Slices or quarters of large fruit, spoonfuls of berries, dipped in batter, taken up with a spoon and dropped into frying fat. **QUEEN FRITTERS**—Puffs or hollow fritters made of same mixture as cream puffs, fried instead of baked. **BEIGNETS SOUFFLES**—Same as queen fritters. **SPANISH PUFFS**—A variation of queen fritters, containing a little sugar and vanilla in the batter, same mixture as for eclairs; fried instead of baked. (*See beignets, corn fritters, apples, parsnip, creme frite, queen, etc.*)

**FROGS**—The frog is one of the regular kinds of meat now kept in stock in all good restaurants during the season, which is fall and winter. The legs are eaten of two kinds or more: the small green marsh frog, which is supposed to be the better, and the large bull frog, which attains to the size of a squirrel in the south. In the course of business it is found that the larger frog's legs have the readiest sale; they resemble chicken in appearance and taste. From 4 to 6 pairs of legs of the large sort is a restaurant portion—12 to 18 pairs of the small. Frogs are caught with a rod and line. A bait of grub or snail being tied to the line instead of a hook, it is trailed along the surface, and the frog springs and

## FRO

swallows it. They are caught also by shooting with an arrow attached to a string, and in nets drawn along the margin of the pond. When caught, they are skinned; the body is thrown away; the legs with enough of the spine to hold the two together are reserved for cooking. In the New Orleans markets, however, may be seen frogs of the very largest size exhibited for sale alive in cages, where they are evidently fed and fattened for market. At the same stalls may be seen frogs skinned and hung up in pairs, looking like white-meated squirrels of the medium size, and not the legs alone, but the entire body, giving evidence that the entire frog is esteemed eatable by some customers at least. **FRICASSEE OF FROGS**—The feet chopped off, the legs are held in convenient shape by thrusting one stump into the meat of the other leg, steeped an hour in water containing vinegar; washed and placed in a saucepan with onion, carrot, celery, a clove, herbs, pepper, salt, and water to cover; stewed about  $\frac{3}{4}$  of an hour. The frogs taken up, the broth strained and thickened with flour and butter; finished with yolks and cream, not boiled; butter, lemon juice and parsley. **FRIED FROGS A L'AMERICAINE**—Frog's legs steeped for an hour in lemon juice, salt and pepper; wiped dry; floured, egged, breaded, fried; dished on a napkin with fried parsley and lemons. **GRENOUILLES A LA VILLEROY**—Frogs cooked as for fricassee, mashed to a paste with Allemande sauce; worked up like croquettes; breaded; fried. **FROG SOUP**—Made of 2 quarts good, seasoned veal-broth and hind-quarters of 3 doz. small frogs cooked in it; frogs taken up, mashed to a paste with bread-crumbs; purée strained back into the soup; yolks of eggs to thicken. **OS DE GRENOUILLES**—Frogs' bones; name of a sweet cracker sold in Paris.

**FROMAGE (Fr.)**—Cheese. **FROMAGE DE BRIE**—Brie cheese. **BEIGNETS DE FROMAGE**—Cheese fritters.

**FROMAGE DE COCHON**—Head cheese; a dish very popular in France; made by taking the skin off a pig's head in one piece, taking the meat from the bone and cutting it up with tongue, ears, some chitterlings, herbs, seasonings; all sewn up in the skin of the head, boiled 3 hours, pressed into a mould and baked a short time; eaten cold.

**FROMAGE D'ITALIE**—Italian cheese, but also the name of a kind of liver cheese reputed to have been a favorite with Louis XI. Made of 5 lbs. liver, 1 lb. lean pork,  $\frac{1}{2}$  lb. fat pork, all minced; pepper, salt, shallots, thyme nutmeg. Placed in an earthen dish lined with shavings of bacon, wine to moisten, bay leaves and bacon on top, baked three hours, eaten cold.

**FROST-FISH**—American small fish, plentiful only in winter; cooked by rolling in flour and frying like whitebait or small trout.

**FROSTING**—Domestic name for meringue or icing of cakes. (*See meringue.*) **FROSTED FRUITS**—Cherries, currants, etc., dipped in white of egg

## FRU

and then in powdered sugar. FROST WORK—For pedestals, cake stands, etc., is done by sprinkling with diamond powder, from the paint shops, on a wet surface; for scenery it is done with ground glass.

FRUITS (Fr.)—Fruits. The same in both languages.

FRUIT CAKE—Various kinds and grades of cakes containing raisins, currants and citron peel.

CHRISTMAS FRUIT CAKE—Made of 1 lb. each butter, sugar, eggs, raisins,  $2\frac{1}{2}$  lbs. flour, 2 lbs. currants,  $\frac{1}{2}$  lb. citron, nutmeg, spice, 1 cup milk; mixed like pound cake, baked in moulds. (See *Dundee cake*.)

FRUIT CAKE—1 cup butter, 2 cups sugar,  $\frac{1}{2}$  cup syrup, 5 eggs, 2 cups flour, 3 teaspoons baking powder, 1 cup each citron, raisins, currants.

FRUIT PUDDING—Commonly understood to mean plum pudding. CHRISTMAS PUDDING—Made of 2 lbs. bread-crumbs, 1 lb. each suet and raisins,  $1\frac{1}{2}$  lbs. currants,  $\frac{1}{2}$  lb. sultanas,  $\frac{1}{4}$  lb. citron,  $\frac{3}{4}$  lb. sugar, 2 tablespoons flour, 4 eggs, 2 cups milk, 1 nutmeg, brandy, spice; boiled 6 or 8 hours.

FUMET (Fr.)—Essence of game; made by frying limbs, bones, carcasses of game in butter with shallots and spices till browned, then stewing with wine and stock, straining and condensing by boiling down. Used for adding to game sauces.

FUNGI—See *agaric*, *cepe*, *champignon*, *morel*, *mushroom*, *orange*, *truffle*.

FURMETY—English, from Latin *frumenti*. Wheat boiled in water until soft, milk and currants added. Whole wheat porridge.

FUSTIC—Venice sumach; a dry wood employed to produce yellow colors.

## G.

GALANTINE—A fowl or other kind of meat, stuffed, boiled, pressed in a mould, decorated, eaten cold. GALANTINE DE DINDE—Boned (or boneless) turkey. A slit is cut down the back, the meat carefully cut from the carcass, laid out flat and seasoned. A filling of either another turkey or chicken, or veal forcemeat or sausage placed upon it, the sides drawn up to the original form, sewn, bound up in a cloth, boiled 3 hours, in stock seasoned, pressed hot into shape; taken out of the cloth when cold. It is then a boned turkey only; becomes a galantine or ornamental dish when decorated by being placed in a larger mould, aspic jelly poured around, the whole turned out when cold and garnished in various ways. GALANTINE DE POULARDE—Boned chicken in jelly. GALANTINE DE VEAU—The fore-quarter of veal, boned, stuffed, rolled, boiled in stock, pressed into a long mould, decorated with jelly, shapes of yolk and white of eggs, beets, lemons, etc. Sliced cold and served with jelly. GALANTINE DE COCHON—Galantine is occasionally made of sucking pig, and is very popular in France. The pig must be carefully boned, all but the head and

## GAM

feet. A sufficient quantity of veal, of fat unsmoked bacon, and of bread panada must be chopped and pounded to make enough forcemeat to stuff the pig in the proportion of one part bacon, two panada, and three of veal, seasoned with a teaspoonful of onion juice and two of powdered sage. Galantines of small birds are called *ballotines*.

GALETTE—A plain shortcake, not sweet, but sometimes sugared over the surface. Same as *Gâteau de Plomb*.

GALLINO RENNET—It is said that the rough skin which lines the gizzards of fowls will curdle milk for making cheese and cheese cakes as well as calf's rennet. The skin is salted and then dried, and a piece steeped in water for 8 hours makes the rennet; 2 or 3 tablespoonfuls to be mixed with the milk.

GALOPIN—Galopin is a local term for a half-bottle of wine. In Paris, the word means a "little rascal," affectionately used.

GAME—Nearly all game is better for being kept, quails, snipe and woodcock being the exceptions. It has been the rule to hang some game birds by the middle feather of the tail and cook the bird when it fell. When game becomes a little too high, permanganate of potash will purify it from the taint, if carefully employed. To keep game however, a better way is to draw it as soon as it arrives; rinse with soda and water, then with pure cold water; wipe dry and rub them lightly with fine salt and pepper. Put a piece of charcoal inside each bird; hang in a cool, dark place, with a cloth thrown over them. Another way strongly recommended is to fill the birds with oats or other dry grain and bury them in grain. Probably, however, cold storage is the best way of all to preserve game as well as other meats. OLD GAME—"People will say: 'What is to be done with old game?' To that question I will simply answer: 'Do anything but roast it.' An old hare or an old rabbit may be turned to account by making it into soup, purée, stew, civet, quenelle, or pie. Of course, it will take a longer time to cook than if the game were young; but as compensation you will find more substance and more flavor in the result. An old bird may be boiled, braized, or made into fricassée, soup, forcemeat, and purée. Clear *consomme du gibier aux quenelles* is a very nutritious soup. It is made with carcasses and bones of old game, the flesh of which has been pounded to make the quenelles that are used as a garnish to the soup. In France, old partridges are mostly used in the form of *perdrix aux choux*. They are braized with cabbage, bacon and sausages until tender. In Germany they substitute sauerkraut for the fresh cabbage. Hares, rabbits, and large birds, such as pheasants, blackcock, etc., require to be thoroughly cooked; but small birds, such as partridges, grouse, woodcocks, snipe, quails, etc., ought to be eaten a little underdone, when they will be more appreciated by the real epicure. Small game is generally dished on toast; bread-sauce is always served with pheas-

## GAM

sants, partridges, grouse, and blackgame; with wild fowl in general, quartered lemons are handed round, and currant-jelly is sent up with roast hare.

## CHOICE-BITS—

“If the partridge had but the woodcock's thigh,  
He'd be the best bird that ever did fly;  
If the woodcock had but the partridge's breast,  
He'd be the best bird that ever was dressed.”

SMALL GAME—“All small game-birds should be roasted in jackets made of very thin slices of salt pork or bacon. Many persons do not like the taste of smoked meats; the pork is therefore much better to use, unless by special order.”

## GAMY HINTS—

“Game (birds) should be hung by the neck, and not by the feet, as is commonly done. Hares should be dressed when blood drops from the nose. The fishy flavor of wild-fowl may be prevented by first boiling them in water in which are salt and onions. Game or wild-fowl for two or three are, however, never better than when broiled.”

## WEIGHTS AND

## TIME—

“The average weight of grouse, partridges, and pheasants, when prepared for the spit, is as follows: Grouse, 16 oz.; partridge,  $\frac{3}{4}$  lb.; pheasant (on the average),  $2\frac{1}{2}$  lbs. The following are the various lengths of time which game requires for cooking, *a point*: Cock pheasant, three quarters of an hour; hen, twenty-five minutes; half-grown bird, a quarter of an hour; hare, one hour and a half; woodcock, half an hour; snipe, twenty minutes; quail, twenty minutes; golden plover, twenty minutes; teal, a quarter of an hour; capercaillie, an hour and a quarter; and wild goose, an hour.”

## THE NATURAL

FLAVOR—“‘In the preparation of game,’ wrote recently an eminent Parisian *chef*, ‘abstain from too much seasoning. Do not use spicy herbs of any kind, and scrupulously avoid all garlic, shallot, and other onion-flavored vegetables. These ingredients destroy the delicate intrinsic savor of game.’ The same person states that *grives*—thrushes—should be served *en couronne*—*i. e.*, in a circle, round a bouquet of smallage and of autumn marguerites. Pheasants should be trimmed with the tail and wing-feathers, and be served holding a rose in their beaks.”

## SYDNEY SMITH ON GRAVY—

“It is wickedness to drench roast game with sauce. Sydney Smith says, in describing a dinner at which he was present: ‘I heard a lady who sat next to me say in a low, sweet voice: ‘No gravy, sir!’ I had never seen her before, but I turned suddenly round and said: ‘Madam, I have been looking for a person who disliked gravy all my life; let us swear eternal friendship.’ She looked astonished, but took the oath, and what is better, kept it.”

## GAME WITH CHESTNUTS—

Pheasants, partridges, quails, grouse, and plovers may all be cooked by the following directions, and they will be found to be very nice: A quart of large chestnuts are boiled and mashed, one-half of it mixed with 3 oz. butter, 1 cup cracker-dust, salt, pepper, chopped parsley. Birds stuffed with it, wrapped in thin slices of cooked ham, then in vineleaves tied on them; baked; leaves and ham removed, chestnut-

## GAM

sauce made with remainder of purée added to gravy made of the livers, etc. NORTHUMBERLAND GAME-PIE—“This ducal dish, for which Alnwick Castle has been for centuries famed, is made thus: A good raised pie-crust is made, such as one would prepare for a large batch of pork-pies, or raised pies. The crust is firm, yet mellow, and will not be like some Melton (?) pies I know (nothing melting about them), which require a hatchet to break them. These cases are quite monsters. The inside consists of 24 pigeons cooked and boned, the flesh pounded in a mortar with the gravy in which they were stewed added; then 24 fowls served in the same way; a layer of fine sausage-meat may be put round the pigeons, which are formed into a long roll, then the fowls, next slices of ham, then boned rabbit, pheasants, partridge, hare, tongue in slices, turkey-flesh, until all is in one huge mass, then the bones of ham shanks, couple of cows' heels, or a knuckle of veal are stewed for hours. The meats are laid into the case; the liquor, when nearly cold and freed from grease, is poured in; the cover put on the pie; baked, then glazed with egg, and the ornaments put on. These will be popular on smaller scales, and to the *restaurateur* they are valuable as they use up odds and ends of game, etc., which whilst being perfectly good are not exactly presentable at table, and too good for the stockpot, their ultimate destination.”

RICHARD II GAME-PIE—“This recipe is to be found in the books of the Salters' Company, and having been tested by their cook, was found to produce an excellent pie; which proves that our ancestors excelled in cookery more than four centuries and a half ago. It is a recipe for making a game-pie for Christmas in the reign of Richard II. Take a pheasant, a hare, a capon, two partridges, two pigeons, and two rabbits; bone them and put them into paste the shape of a bird, with the livers and hearts, two mutton kidneys, forcemeats and eggballs, seasoning, spice, ketchup, and pickled mushrooms; filled up with gravy made from the various bones.”

LITTLE GAME PIES—Raised-pie cases 3 or 4 inches diameter are made and baked with a filling of flour to keep them in shape; when done, the flour brushed out, and cold galantines of game and imitation *foie-gras* cut small and mixed filled in, and aspic jelly poured in to level up; lids separately baked put on and decorated.

THATCHER HOUSE GAME PIE [specialty]—Is made in the following manner: Rub the inside of a deep dish with two ounces of fresh butter and spread over it some vermicelli. Then line the dish with puff-paste; have ready some birds seasoned with powdered nutmeg and a little salt and pepper; stuff them with oysters or mushrooms chopped fine; place them in the puff-paste lined dish with their breasts downward. Add some gravy of roast veal or poultry (it may be cold gravy saved over from a recent roast), and cover the pie with a lid of puffy paste. Bake it in a moderate oven; and when done, turn it out carefully upon a dish and send it to the table. The vermicelli, which was originally at the

## GAM

bottom, will then be at the top, covering the paste like thatch upon a roof. Trim off the layers so as to look neat. **PUREE-OF-GAME SOUP**—The game is boiled in stock or water with carrots, onions, celery and herbs; when tender, the meat mashed, rubbed through a strainer, mixed with bread-crumbs, and the stock strained to it. Served with croutons of fried bread. (*See Grouse and other kinds.*)

**GAMMON OF BACON**—A leg of salt pork. English corruption of the French *jambon*, ham.

**GARBURE**—"I remember some time ago six American gentlemen from New York came to Bignon's and said: 'Now, Joseph, we want a thoroughly good dinner.' I asked them what they wanted, and they insisted on leaving it to me. Well, this is what I gave them: First a *potage garbure*; then *pommes georgette*; next a quail for each guest. And would you believe that during their stay in Paris they ordered that same dinner of *garbure*, *pommes georgette* and roast no less than eight times, of which four times running?" Garbure is something which is served with soup rather than the soup itself; it is crust of bread baked in a dish of fat broth; any sort of vegetable may be prepared and poured over the baked but softened bread, and the real soup is served separately. It is eaten by each person taking a spoonful of the bread from the baking dish, its top-dressing of vegetable with it, and adding a ladleful of soup to it in the soup-plate. In the instance above mentioned the baked bread had a dressing of parmesan cheese, and the soup served with it was *Julienne*. **GARBURE WITH CABBAGE**—Cabbages stewed with small sausages and bits of bacon; top-crust of rolls baked in a dish with enough beef-broth to moisten; the cabbage served on the bread; beef-broth or other soup by the side. **GARBURE WITH CUCUMBERS**—Cucumbers in inch-lengths, parboiled, then fried in butter, then stewed, served on top of crusts baked in broth; a vegetable-soup in another tureen. **GARBURE A LA CLERMONT**—Onions in rings fried to a yellow color, then stewed in broth, poured over the baked crusts; beef-broth served in another tureen. **GARBURE A LA FRENEUSE**—Turnips cut in pieces, fried, then stewed, poured over the baked crusts; beef-broth served separately.

**GARGANTUA**—Rabelais, a French humorous satirist of the sixteenth century, describes the doings of Gargantua, who ate cattle as common people eat chickens and was in all a wonderful glutton; hence the allusions occasionally to *Gargantuan Feasts*, meaning something extraordinarily large, and *Gargantuan Feeders*, meaning great eaters. "The following is a list of the *hors d'œuvres* served at a Gargantuan repast: *Caviare*; *bontargues* (sausages made out of caviare); *beurre frays* (fresh butter); *purees de pois* (purée of peas); *espinars* (spinach); *arans blans boufflz*, *arans sors* (fresh and pickled herrings); *sardines*, *anchois*, *tonnine* (tunny); *caules emb' olif* (cabbage preserved in oil); *saulgre-nees de febres* (Macédoine of beans); *sallades cent*

## GAS

*diversites* (a hundred different salads), of which are mentioned cress, hops, samphire, mushrooms, asparagus, and honey-suckle salad; pickled salmon; salted eels; *huytres en escalies* (oysters in their shells.) This is from a French sixteenth-century *menu*. It seems to me that caterers in quest of novelties for the construction of their *menus* might do worse than consult Master Rabelais."

**GARFISH**—A river-fish destructive to other fishes, generally thrown away as worthless when caught. It is said the strong oily taste of this fish is no deeper than its skin, and after skinning and steeping in water with vinegar and salt it is good cooked in the same ways as eels.

**GARLIC**—A bulb like an onion; useful for flavoring if used with great care. Its taste, if strong, is very generally objected to by unaccustomed palates, though it is eaten raw with bread, the same as onions, by people of southern Europe. It can be bought of Italian and Spanish gardeners or provision dealers. **A CLOVE OF GARLIC**—Means one of the natural divisions of the bulb, not a head of garlic. Generally it is sufficient to rub the salad dish with a slice of garlic, or to rub garlic on a crust of bread and stir that up in the salad, or in a stew or soup.

**GARNISH**—A garnish is a ragout or mixture of various tasty morsels in rich sauce, and as the whole is made up of several parts necessity has prompted the naming of many of the garnishes; thus a *Richelieu garnish* or a *Financiere garnish* always mean the same things respectively without going into the detail of their composition, and a piece of meat or a fowl served with either garnish in the dish is named accordingly: *a la Financiere* or *a la Richelieu*. The misfortune of the case is that garnishes and names are too numerous and the motive is too small for anybody to learn more than about half a dozen characteristic compounds.

**GARNISH**—To garnish or decorate a dish with something to enhance its attractiveness, such as the bordering a salad with capers, parsley, beets or lemons.

**GARNISH**—Culinary expression meaning to fill up, as when a shell of paste has been baked for a *pâté* the directions run to garnish the pie case with fat livers and boned birds; or to garnish a border of rice by filling it up with the sweetbreads prepared for the purpose.

**GARUM**—One of the two principal sauces used by the ancient Romans, often mentioned by old authors; a kind of soy, "the Romans knew and appreciated the appetising charms of the oyster, albeit it was served up with garum, a sauce made from putrid fish which would disgust a modern gourmet."

**GASPACHO**—*See Spanish Cookery.*

**GASTRONOMY**—The science of the stomach. The knowledge of what, how, and when to eat.

**GASTRONOMER**—One who secures the utmost

## GAT

enjoyment of the pleasures of taste within the limitations of the laws of health.

**GATEAU**—(Fr.)—Cake. The forms of gateaux are as various as the forms of cakes. The term means almost anything from a cream pie to an ornamented tall cake for a party. **GATEAU BABA A LA MONTMORENCY**—A rich yeast-raised cake baked in an ordinary tube cake mould, the top crust cut off and kirsch syrup poured into the cake; apricot jam spread thinly over, icing over that; made cold. When served the hollow filled with red currant ice cream and candied cherries. **GATEAU MAZARIN**—A baba or yeast-raised cake, rich with butter and eggs, but without sugar, baked in a plain mould lined with almonds, split like a short-cake, when done, and thick rum pudding sauce, containing chopped citron and butter poured on both halves. The two saturated halves are then placed together and the cake served hot on a folded napkin. Suitable for ball suppers and large parties. **GATEAU GENOISE AUX APRICOTS**—A jelly cake 6 or 8 inches high, half of it cut out from the center to form a well in the middle of the cake. Entire surface spread with apricot jam and decorated, served with apricot compote and whipped cream in the center. **GATEAU DE AMANDES A LA PARISIENNE**—A sheet of puff paste with raised edges, filled with almond custard, covered with a thin top crust, egged over, sugared, baked. **GATEAU A LA D'ARTOIS**—Same as the preceding if made with jam or marmalade. **GATEAU DE PLOMB**—A plain rich shortcake, made of 1 lb. flour, ½ lb. butter, 1 cup cream, 1 spoonful sugar, salt, egged over, baked like a large plain biscuit; eaten with butter and fruit. **GATEAU NAPOLITAINE**—Almond flavored jelly cake, iced and decorated. **GATEAU A LA VICTORIA**—A light baba or yeast raised citron cake, served hot with almond custard. **GATEAU SAINT LOUIS**—A puff paste sheet with raised edges filled with almond white frangipane, chopped almonds on top, baked; similar to white cocoanut pie. **GATEAU SAINT CHARLES**—An almond cake baked in a mould lined with paste. **GATEAU DE RIZ**—Rice cake. **GATEAU DE MILLE FEUILLES**—Thousand leaf pastry; jelly cake made of baked sheets of puff paste piled on each other with jelly between. **GATEAU NAPOLEON**—Two sheets of puff paste baked thin and dry, spread between with frangipane; cut in pieces to serve. **PETITS GATEAUX**—Small cakes. **GATEAU FAUCHETTE**—A Paris specialty, made by removing the center from a freshly baked sponge cake, filling it with almond frangipane; turning it over on a dish, covering with meringue, with granulated sugar sifted over the surface, and baking sufficiently to slightly color the outside, spotted with currant jelly; served on a folded napkin, hot. **GATEAU REINE CLAUDE OR STANLEY**—A cake hollowed in the middle, spread over ("masked") with green-gage marmalade, filled with green-gage ice cream. (See *Ices*.) **PARIS SPECIALTY**—"MEM.: Spinach in slight quantities is very useful for giving a bright green color to such

## GEN

entremets as ices and creams. It is used in this way for "shading" Reine Claude ice cream, which would otherwise have a dull color. This Reine Claude cream is now much used for filling Stanley cakes, as the new fashionable entremets in Paris is called. The "gâteau Stanley" is the invention of *Chef Lucien Chardon*, and is made with baked baba dough soaked in almond syrup, glazed with sugar-glazing, and masked as above."

**GAUFFRE** (Fr.)—Wafer; waffle.

**GELATINE**—Made first by Prevost about 1735, the same who took in partnership Phillippe, who afterwards became celebrated for his restaurant in Paris. It is refined glue; may be obtained by boiling down calves' feet, head, ears or skin until they are dissolved, straining the liquor and then drying it on shallow dishes. The transparency of some kinds is due to clarifying processes. The whitish kind in sheets is porous through being churned while cooling, which makes it easier to dry, and is an advantage in cooking as it floats in the liquid and cannot burn on the bottom as the transparent kinds do. Gelatine is one of the expensive articles of hotel provision. The dearest is not necessarily the best. The jellies to be made have to be clarified by the cooks and one kind of gelatine is as good as another provided it is without flavor. If kept in a drug store gelatine will often acquire flavors from neighboring substances that render it quite worthless. The quantity required is 1½ ounces for 1 qt. of jelly, or 1 oz. for 1 qt. of milk or cream for blanc mange, but more in warm weather than in cold. **PORTABLE JELLY**—Gelatine jelly can be made of double strength, then dried down to the consistency of gum drop candy, in small pieces or shreds, and kept, and when wanted to make jelly can be dissolved in the right measure of hot water, and will be jelly as soon as it can be made cold enough to set. (See *Jellies, Asp c, Cremes*.)

**GELEE** (Fr.)—Jelly.

**GELINOTTE**—Guinea hen, hazel hen.

**GEM PANS**—American dariole moulds, made of iron or tin, cast or joined together in sets of 10 or 12; made of various depths, generally hold 2 ounces, are round, oval or scalloped.

**GEMS**—American hot breads baked in gem pans. **CORN GEMS**—Corn meal, milk, butter, eggs, salt, baking powder, and little flour, mixed thin enough to pour out of a pitcher; gem pans filled and baked. **GRAHAM GEMS**—The same made of Graham flour. There are several varieties; some sweet. **WHEAT GEMS**—Usually called wheat muffins, made both with yeast and baking powder; there are various qualities.

**GENEVA BUNS**—Sweet rolls made either by adding to light bread dough some enriching ingredients, or with 2 lbs. flour, 1 oz. yeast, 1 cup warm milk, to set sponge; 2 eggs, 6 oz. sugar, 6 oz. melted butter worked in; made in long buns, pruned till quite light, baked 15 minutes, sugared over.

## GEN

**GENEVA**—The term geneva, or gin, is derived from *genievre*, the French word for juniper-berries. The fruit of this tree was tried by Sylvius, a professor of Leydon, who lived in the seventeenth century, and found that it not only gave a very agreeable flavor, but also possessed many valuable medicinal properties. In consequence this liquor was for a considerable time sold as a medicine by the apothecaries, but on its excellent qualities becoming better known, it was made on a more extensive scale, and then received the name of the plant to which it owed its peculiar flavor.

**GENEVA WAFERS**—Same as wafer jumbles, which run out thin in baking; can be taken up hot and bent around to conical shape to hold whipped cream; made of 4 oz. butter, 3 oz. sugar, 3 eggs, 4 oz. flour; vanilla flavor; well beaten together, dropped on pans with spoon.

**GENEVA PUDDING**—Rice boiled in milk, and purée of apples mixed together with eggs and wine, sugar and butter; baked; wine sauce.

**GENEVOISE** (*a la*)—In Geneva or Swiss style, or with Genevoise sauce.

**GENEVOISE SAUCE**—For fish. Brown sauce with 2 oz. lean ham cut in pieces, a carrot, onion, bay leaf, 3 cloves, peppercorns,  $\frac{1}{2}$  clove of garlic, parsley, thyme, butter; all simmered together till onion is tender; 1 pt. claret added; boiled down; espagnole or brown sauce, or butter and flour, and stock; salt, pepper; strained through a napkin by twisting; anchovy essence and butter beaten in.

**BROOK TROUT A LA GENEVOISE**—Speckled trout trussed with the head to the side to keep them in upright position, cooked in equal parts red wine and broth with garlic and herbs in a fish-boiler for 30 minutes; drained and served on a folded napkin with Genevoise sauce, made of part of the fish-liquor, served separately.

**GENOISE SAUCE**—For fish. Good brown sauce with chopped parsley, a glass of port, teaspoon of anchovy essence, walnut catsup, pinch of mace; boiled few minutes.

**GENOISE CAKE**—Rich almond pound-cake of several grades. (1)—Made of 1 lb. each sugar, butter, almonds, flour, eggs, and a wine-glass of brandy. The sugar and eggs whisked together until thick and light; the almonds powdered and sifted; flour and butter all stirred in; baked in moulds or in thin sheets. (2)—**ROYAL GENOISE**—A London specialty; made of 1 lb. sugar, 16 eggs,  $\frac{1}{2}$  lb. butter,  $\frac{3}{4}$  lb. flour,  $\frac{1}{4}$  lb. ground almonds; flavored with vanilla, almond and lemon; sugar and eggs whisked light; butter warmed and stirred in with the flour and almonds; baked in sheets; not cut till cold. (3)—**ORDINARY GENOISE**—Made of same as the first above without almonds. Better with 2 eggs less, or 1 lb. of flour, 1 lb. of pulverized sugar, 1 lb. of butter, 8 eggs, a little salt, and a few drops of essence of lemon.

**GENOISE PASTRY**—Name given to small squares or

## GER

shapes of genoise cake with jelly spread between, and pink and white icing on top; cut out of large, thin sheets of cake. Favorite kind for parties.

**GENOA CAKE**—(1) Genoise cake with currants, raisins, citron and ground cinnamon mixed in; baked in a shallow pan; glazed with sugar and chopped almonds, and baked to dry them. (2)—One pound butter, 1 lb. sugar,  $1\frac{1}{2}$  lbs. flour, 9 eggs,  $1\frac{1}{2}$  lbs. currants,  $\frac{1}{2}$  lb. citron; lemon flavor.

**GEODUCK**—“The greatest curiosity of all at the dinner was, however, the geoduck. It is an immense clam, the largest in the world. One will fill a bushel-basket. They are found only in Puget Sound, Washington Territory. Government officials tried to bring one alive to the Smithsonian Institute, in Washington, in 1882, for the United States Fish Commissioners. The specimen was boxed and taken by steamer to San Francisco, where it gave up the ghost. Its scientific name is the *Glycerinus*. It resembles a great fresh-water clam in form, color, and texture of shell.” There is another, an East Indian clam of immense size; a single one will make a meal for ten men. The shells are deeply and handsomely scalloped, and are to be seen at the shell stores.

**GERMAN COOKERY**—To appreciate German cookery and to enjoy thoroughly some of the real delicacies it produces, it is necessary first to abandon all American ideas on the fitness of things, and when you have succeeded in doing so get rid of the English and French ones as well. For a stranger the dinner hour in any German city is a most puzzling matter. He may begin a round of visits at one o'clock and continue them till five, finding everyone at dinner. For, although the most usual time is one or half-past, the Emperor dines at four, most of the government employés at half past two, and the wealthy class at five. The most characteristic meal in the southern portion of the Empire is the *jause*, which, like the English “tea,” comes between dinner and supper. The ladies ask each other to their apartments, drink coffee and eat *kugelhuff* (a species of fine pound cake with very large holes in it—yeast-raised *kauglauf*) and *kipfel* (little rolls in the shape of a horn). The men meet in the cafés and take similar refreshments. The customary dinner of the upper middle class is soup; boiled beef with sauce, vegetables, pickles; roast veal or poultry, and either salad or a pudding, on Sunday both salad and pudding. The favorite sauce with beef is horse-radish (*kren*) and onions. Your German friend cuts all his meat in pieces, dips each piece systematically into all the little vegetable or sauce dishes, which are grouped around, before he puts it in his mouth. The German states are better supplied with game than any other part of Europe. The Bohemian pheasants (*faisans de Boheme*) are celebrated. Capercailzie and black-cock come from the Styrian mountains. Hares are exceedingly numerous; venison abounds. The vast, swampy reaches of the rivers afford snipe and duck-shoot-



## GER

ing in abundance. Two or three times a year wild geese in immense flocks fly across the country and great numbers are killed. Woodcocks and gelinottes are brought to market from Hungary; in short, nowhere is the material for good living more plentiful or cheaper than in the German markets. In order to enjoy any of these, however, it is quite essential for the stranger to warn the headwaiter that the bird ordered must be brought in whole for the guest to do his own carving, that art being utterly unknown, at least in the public cafés, and method substituted for carving is a barbarous chopping of every bird or fowl straight across in halves and quarters, limbs, breast, bones, splinters, all mixed up together. In early summer *back-hendl* is the favorite delicacy. It is spring chicken bread-crumbed and fried. Next to *back-hendl*, the most universally liked dish is *Wiener-Schnitzel*. This is simply a veal cutlet breaded and fried, with slices of lemon around it. It is a safe thing to order almost anywhere; you can eat it in a *Bierhalle* or large middle-class restaurant, where very little else would be worth having. The special forte of Viennese cooking lies in the sweets. The soufflets, puddings, tea and dinner cakes, brioche and tarts of Vienna are unequalled even in Paris. The way an Austrian cook makes a rice pudding is sufficient to convert even a school boy to love plain puddings. The variety of German sweets (*Mehlspeisen*) is enormous, it would fill pages to describe them. GERMAN DISHES—These are dishes which one traveler did not relish and he thought them strange, though they seemed good to his German entertainers: Cold potato salad, boiled beef and raspberry jam, spinach fried in butter, wine and raisin soup, pancakes three inches thick fried in the oil of Spanish onions, pork sausage fritters, raw herrings and cucumber with treacle sauce, veal cutlets garnished with boiled stick liquorice. GERMAN POTATO SALAD—The ingredients of a real German winter salad are cold boiled potatoes cut up into quite small pieces, some capers, or a few olives chopped up, anchovies stripped off the bones and cut into small pieces, and a little finely-chopped parsley. To these may be added beetroot and celery, if desired, which should also be cut up into small pieces. All the ingredients to be well mixed. For the dressing, to the proportion of two eggs—of which the yolks, hard boiled, only are used—put one tablespoonful of salad oil, a little cayenne pepper, salt and mustard to taste; and a small teaspoonful of pounded loaf sugar. When these are well mixed, add three tablespoonfuls of cream or good milk, and, lastly, stir in one tablespoonful of vinegar. Pour the dressing over the salad just before serving. GERMAN VEGETABLE SOUP—One of the most nutritious and appetising soups known to the German gourmet. Put into a stew-pan 12 onions, 1 turnip, and a head of cabbage,  $\frac{1}{4}$  lb. of butter, and 1 qt. of white stock; stew till tender. Add another quart of stock, pulp the vegetables, and

## GER

boil with the soup  $\frac{1}{2}$  an hour, stirring constantly; just before serving stir  $\frac{1}{2}$  pt. boiling cream and about 20 button onions picked and boiled soft in milk and water. Season with salt, and thicken, if desired, with rice-flour worked with butter. GERMAN STEWED EELS—Cut in 3 inch pieces, steeped in salt water an hour; butter and flour fried together and water to make sauce of it; garlic, sage leaves, bay leaf, mace, cloves, Rhine wine, eels put in and simmered an hour. GERMAN ROAST GOOSE—The goose wiped inside and filled with small whole apples, cored but not peeled; also a small bunch of mugwort. Sewed up, salted, the goose fat spread over it and buttered paper; roasted in the oven 3 hours; gravy made in the pan. BEEFSTEAK MIT SCHLAGSAHNE—"I have dined and lunched at the Zum Kniephof since, and have been contented with the fare. I shall speak about its bill of fare on a future occasion, mentioning, meanwhile, that beefsteak *mit Schlagsahne*—that is, with whipped cream on it—is a specialty of the house. German people like their beefsteaks served with all kinds of curious additions, as with two poached eggs, or sardine-butter on the meat. The beefsteaks are always good, being cut from the fillet. I have not had a single tough beefsteak, or other piece of meat, since I have been here." KNIEPHOF BROEDCHEN—"Another specialty at the Zum Kniephof is the *Kniephof Broedchen*, or sandwich. I asked for a plate of this out of curiosity, and found it to consist of six slices of roll, each differently spread, one with a caviar, two with sausage, one with veal, one with beef, and one with cheese, arranged in star-fashion round a centerpiece of a leaf of lettuce, some chopped cucumber, and an anchovy. The price of this assortment, which constituted a complete meal, was only 6d." KRAMMETSVOGEL—"Another not so substantial but tasty dish is that of *Krammetsvogel*, which we call the field-fare. This little bird, roasted and served upon buttered toast, is in taste by no means distant from the snipe, and, indeed, but for the beak, might well be mistaken for it. Sauerkraut accompanies the dish, and for one of these winter tenants of the fields the diner is charged during the hours of the mid-day meal the sum of 3d., a not high price for a dainty morsel." CARAWAY MAYONNAISE—"The refreshments consisted of a very well stocked cold buffet, from which I fetched a plate of the best roast-beef I have ever eaten. It was served with mayonnaise sauce, which was flavored with caraway seeds." GERMAN HOTCH-POTCH—Neck of mutton broth with dried green peas and carrots and turnips cut small, and celery root or seed; boiled  $1\frac{1}{2}$  hours, some mutton chops added; seasonings, chops and soup served together. GERMAN GIBLET SOUP—Purée of white beans with some whole boiled beans added, and giblets cut small, stewed tender and mixed in. GERMAN GIBLETS WITH APPLES—Brown giblet stew in the middle of the dish, gravy from them mixed with apple juice and zante currants poured over; quarters of apples stewed with

## GER

sugar and butter placed around. GERMAN GIBLETS WITH PEARS—Goose giblets and pork chops stewed together; quartered pears stewed in the giblet liquor with cloves and sugar and served around the giblets in a dish. GERMAN GIBLETS WITH TURNIPS—Stewed giblets cut small, served with slices of stewed turnips in thick sauce, and sippets of toasted bread. GERMAN TOAST—Canapes of toast spread over with minced stewed meat with its sauce, the meat to be stirred over the fire first, with eggs, parsley and seasoning; after spreading, covered with crumbs and browned. GERMAN SAUCE—For cold meats, boar's head, etc., currant jelly, juice and shredded rind of an orange, horseradish, sugar, mustard, vinegar, salad oil. The jelly to be melted and the rest stirred into it. GERMAN HORSE RADISH SAUCE—Grated horseradish and stewed apples in equal quantities, with vinegar and little sugar. FRANKFORT SAUSAGES—Made of lean pork, fat bacon, red wine to moisten, ground coriander seed, nutmeg, salt, pepper, boiled, smoked. CHICKEN KLOSSE—Forcemeat balls of raw chicken, suet, bread, eggs, parsley, seasoned, boiled in clear soup. GOOSE LIVER KLOSSE—Forcemeat balls of minced liver with bread, milk, eggs, etc., to make up into a paste; may be either boiled in soup or fried same as croquettes. HERB KLOSSE—Bread-crumbs, grated cold potatoes, flour and eggs, spinach and other herbs parboiled, all made up into forcemeat balls, boiled, rolled in fried bread-crumbs, served with meat or alone. POTATO KLOSSE—Potato croquettes. POTATO KLOSSE WITH SUGAR—Sweetened potato croquettes served with sugar. KLOSSE—Can be made of any kind of meat mixed with soaked bread-crumbs and seasoning, either boiled or fried, served in soup, or with meat-stews or alone; should be sent to table hot and light as soon as done. MEHL STERZ—Thick mush or porridge of oatmeal or any kind of meal with plenty of butter stirred in. HEIDELBERG PUNCH—Pieces of cucumber sliced, 1 lemon rind, 3 tablespoons sugar, worked together with the back of a spoon; 3 tablespoons brandy, 6 of sherry, 1 bottle claret, 2 bottles soda water. GERMAN HONEY CAKES—Square small cakes with citron strips and almonds on top, made of 8 oz. honey, 2 oz. butter, boiled together; rind of  $\frac{1}{2}$  lemon, 2 oz. almonds, pounded nutmeg, 8 oz. flour,  $\frac{1}{2}$  oz. soda dissolved in little water. Stand till next day, rolled out thick, decorated, baked. GERMAN CAKES—Cookies, made of  $1\frac{1}{2}$  lbs. sugar,  $\frac{3}{4}$  lb. butter, 4 eggs, 2 lbs. flour, 1 lb. currants, nutmeg, rosewater to flavor. Rolled out and cut in cakes. GERMAN OMELET—An egg pancake, baked on both sides; made of 2 spoonfuls flour, 3 eggs,  $\frac{1}{2}$  cup cream or milk, salt, pepper, nutmeg, little chopped chives and parsley. When the pancake is baked on both sides it is spread with purée of mushrooms and rolled up; cut in pieces, served around a center of vegetables in the dish. GERMAN ALMOND CAKES—Made of 1 lb. butter, 1 lb. sugar, 3 eggs, 2 lbs. flour, 1 gill rose water, 8 oz. almonds, 1 teaspoon

## GIG

cinnamon. Rolled out, egged over, the blanched almonds chopped, and sugar spread over; cut in cakes and baked. GERMAN CREAM—Rich cream boiled up, flavored with sugar, lemon and brandy; served cold in a state of froth by being shaken up. GERMAN CROUSTADES—Patty shapes of fried bread filled with minced chicken. GERMAN FRITTERS—See *Berlin pancakes* and *apple fritters*. GERMAN CUP PUDDINGS—Made of 2 oz. flour, 4 oz. butter, 1 pt. milk, 2 oz. sugar, 3 eggs, lemon flavor; the flour stirred up with the milk, butter softened and beaten in with sugar and eggs, baked in buttered cups; whipped German custard sauce. GERMAN PUDDING, STEAMED—Made of 8 oz. bread-crumbs, 3 oz. each sugar and butter, 4 eggs. A layer of this mixture alternately with layer of jam or jelly in a mould; steamed. GERMAN RICE PUDDING—A rice and raisin custard, made of 4 oz. rice boiled in 1 pt. milk, mixed with 4 oz. butter, 2 oz. almonds pounded (or paste), 2 oz. each sugar and raisins, little cinnamon, 3 yolks. Just before boiling or baking, 3 whipped whites stirred in. GERMAN PUDDING SAUCE—Light wine with sugar boiled up and poured to beaten yolks, not allowed to boil again, but whipped to froth and served hot. GERMAN PUFFS—Made of 1 qt. milk, 8 oz. flour, 8 oz. butter, 2 eggs, nutmeg and cinnamon. Flour stirred up with milk, softened butter beaten in, eggs whipped stirred in; baked in buttered cups, served with pudding sauce, or hot for breakfast. CAGE BIRD PASTE, GERMAN—Made of 4 hard-boiled yolks pounded in a mortar with 1 lb. white pea meal and 1 tablespoon olive oil; mixed to a dough, pressed through a colander to form grains like shot, fried over the fire light brown, put away dry for use.

GHERKINS—Small cucumbers of a dwarf kind; also young common cucumbers. Used for pickling.

GIBIER (Fr.)—Game. PATE DE GIBIER—Game pie.

GIBLETS—The neck, liver, gizzard, heart and feet of geese and ducks and similar trimmings of any fowls. PATE D'ABATIS D'OIE—Pie of goose-giblets. ABATIS DE DINDE—Turkey-giblets. GIBLET PATTIES—The gizzards boiled until tender separately; then cut from the hard skin into small dice; livers, etc.; stewed in wine-gravy; gizzards added; filled into patty cases, or croustades, or cassolettes. GIBLET SOUP—Good stock of mixed meats and poultry; giblets and vegetables cut in dice in it, and little barley or rice.

GIGOT (Fr.)—Leg or ham; especially a leg of mutton. GIGOT ROTI—Roast leg of mutton. GIGOT BOUILLI AUX CAPRES—Boiled leg of mutton; caper sauce. GIGOT A LA POLONAISE—Leg of mutton in Polish style; braised, cut in slices without severing them from the bone, and a stuffing put between each slice. GIGOT A LA BRETONNE—Leg stuffed and braised; served with Bretonne sauce and stewed white beans. GIGOT A LA RUSSE—Leg of mutton roasted, and the cooking finished in burning brandy;

## GIN

served with the gravy and brandy. GIGOT A LA PROVENÇALE—Leg of mutton with strips of garlic inserted; roasted and served with Bretonne sauce. GIGOT D'AGNEAU A LA PALESTINE—Leg of lamb boiled; served with purée of Jerusalem artichokes. GIGOT D'AGNEAU AUX EPINARDS—Leg of lamb with spinach. GIGOT DE PORC BOULLI—Boiled leg of pork with vegetables. GIGOT DE PORC A LA PIE-MONTAISE—Leg of pork roasted; served with brown sauce, pickles, and olives. GIGOT DE PORC A L'ALLEMANDE—Leg of pickled pork boiled, and served with cabbage, sauerkraut or other vegetables. GIGOT D'OURS—Leg of bear.

GIN—Spirit made from wheat or other malted grain, flavored with juniper berries. “In the reign of Henry XIII it was decreed that there should be but one maker of *aqua vitæ*, as whisky and gin were then called, in every borough, under a penalty of six shillings and eight pence, a sum of much more value in those days than it is now. Some idea of the extensive trade done at the present time in this spirit may be gathered from the fact that there are at Schiedam alone upwards of 300 distilleries, or rather manufactories, of malt wine, which is the basis of prime geneva. Juniper berries are round, of a blackish-purple color, and contain an essential oil which, when obtained separately, is of a greenish-yellow color, and resembles in odor and taste oil of turpentine. It is greatly superior and far more beneficial to the health than the latter, but owing to its greater price oil of turpentine is largely used by the less conscientious distillers.

GINGEMBRE (Fr.)—Ginger.

GINGER—The root of a reed-like plant with annual leafy stems 3 to 4 feet high. Cultivated in warm countries; does not grow wild. The common brown ginger-root is in its natural state; the white, known as Jamaica ginger, is the root scraped and washed free from its outer coating. Ground ginger is considerably adulterated, generally with starchy substances and also with old ginger from which the “essence of ginger” has been extracted. GINGER PUDDING—“For a wonder the confirmed joker of a proprietor was serious! He didn't perpetrate above three puns and four witticisms per minute! On his *menu* for the day was ginger pudding, and he asked me to try it, which I did. It is such a capital, yet inexpensive specimen of culinary art that I asked him for the recipe. Here it is: *Ginger Pudding*—2 lbs. bread-crumbs,  $\frac{3}{4}$  lb. finely chopped suet, 1 lb. molasses,  $\frac{1}{4}$  lb. sugar, 1 oz. baking powder,  $\frac{1}{2}$  oz. ground ginger, 3 eggs; boil in buttered moulds; should the mixture be too stiff, add a little milk *sparingly*; the pudding ought to come out of a light golden color, and be as light as a feather. I commend this to caterers who have to give plenty for money.” “I have met another ginger pudding of late, which has about a dozen different names. The most popular, however, are ‘Chinese Pudding’ and ‘Golden Pudding.’ This new thing is merely a very light

## GLA

but sweet *plain* pudding with lumps (about 1-inch cubes) of Chy-loong preserved ginger in it, and served with custard sauce colored with saffron. *On dit* that this novelty originated at Smedley's Hydro, at Buxton.” GINGER BEER—Is made of  $2\frac{1}{2}$  lbs. sugar, 2 oz. bruised ginger, 4 lemons (rind and juice),  $\frac{1}{2}$  oz. cream tartar;  $2\frac{1}{2}$  gls. boiling water poured to them in an earthen jar; when cold, little yeast added; stand till next day; then bottled, and corks tied down; ready for use in 2 days. GINGERBREAD—Old-fashioned sort made of  $1\frac{1}{2}$  lbs. black molasses,  $\frac{1}{2}$  lb. butter, 3 eggs, 1 oz. ginger,  $\frac{1}{2}$  lb. brown sugar, 24 oz. flour, caraway seeds, candied peel, juice of lemon, 1 teaspoon soda; all mixed over night, worked like bread, baked in flat sheet 1 inch thick, brushed over with milk. THIN GINGER WAFERS—Pounded ginger, 1 oz.; butter, 4 oz.; flour, 4 oz.; golden syrup, 4 oz. Beat the butter and mix with the golden syrup; stir in the flour and ginger; roll out thin and bake for 15 minutes in slow oven; roll like wafers whilst warm. GINGER SNAPS—One pint molasses and 1 cup lard heated together and poured hot in 1 qt. flour, 2 teaspoons soda and 2 ginger; let this dough cool, add flour enough to roll; roll thin and bake quick. GINGERBREAD FAIR—“The great gingerbread fair is in full swing now at Paris. I have often wondered why the Paris Municipal Council don't tender for the unsold stock of the vendors of gingerbread. The wood-paving they use is so unsatisfactory that something more solid, more heavy, and more wear-resisting might well be tried in its stead!”

GIPIY PUDDING—Or gipsy cake; also called tipsy cake and tipsy parson. A sponge cake pricked all over with a fork is saturated with wine and brandy poured over it at intervals as it soaks up the liquor. Split-almonds stuck all over it, rich flavored custard poured around and served with it, cold.

GIRAUMONS (Fr.)—Vegetable marrows; summer squashes.

GLACE (Fr.)—Means both iced or glossed over, as an iced cake, and frozen. CREME GLACE—Ice cream. BISCUITS GLACES—Cakes of ice cream.

GLADSTONE PUDDING—A pear custard pie made of a layer of lady fingers in bottom of dish, canned bartlett pears sliced over them, yolk-of-egg custard poured in, puff paste crust on top, egged and sugared; glass of sherry in when done; served cold.

GLAZE—It is what remains when meat liquor is boiled down till nearly dry; it is extract of meat; it is meat gravy dried down thick enough to set solid when cold. It is improved by the cooks by flavorings of herbs, etc., added while it is boiling, and is strained and skimmed, making it a brown, stiff jelly; but that from chicken and veal is not dark, and is mentioned in cooking directions as white glaze. Used to add to sauces to make them rich and meaty, and to enrich soups when the meat is insufficient; also used to glaze or varnish over

## GLA

cooked meats and vegetables before sending them to table, making them glossy and tempting in appearance. "The glaze is melted like glue and applied with a brush like varnish; a glaze-pot is made on the same principle as a glue-pot. I remember some years ago getting up a dinner where the kitchen windows abut upon the pavement of Park Lane, by Hyde Park. I was engaged in glazing some hams and tongues, when I became aware that my proceedings were being intently watched by a group of street arabs, one of whom could contain his feelings no longer, but shouted to his pals: 'Hi! look 'ere, see! why, the cove in the white jacket is a-varnishing the meat.' Buy glaze from the *chefs* in gentlemen's families; the ordinary glaze of general commerce is made from beef only reduced to a sort of glue, but a *chef's* stock or bone-pot in a good family contains beef, veal, and the carcasses of poultry and game, thus forming a much richer and tastier glaze than if from beef only, which is comparatively insipid. After the soups and sauces are made from the first boilings, the pot is boiled up with all the scrap bones and meat cuttings and all other good things; it is then strained off and boiled down rapidly until it assumes the consistency of glue; it is then poured into skins while hot, or into basins and solidifies into solid essence of soup, differing from the essence of beef sold by manufacturers, in the fact that it contains the gelatine as well as the meat, poultry and game essences. You can sometimes arrange to buy this glaze from *chefs* at 2s. 6d. per lb., as after reserving an abundant supply for family use, the overplus is generally the *chef's* perquisite. This glaze dissolved in boiling water and boiled up makes splendid clear soup."

GLACE DE VIANDE—"One of the last authorities on the dying art of cookery in France, the last eloquent writer thereupon, the Marquis de Cherville, published a few days ago a learned article on Dumas *pere* from the gastronomical point of view; and, speaking of his proficiency and of his fidelity to tradition, said: 'Never would that genuine artist have allowed himself in the confection of a sauce, to accept *bouillon* as a substitute for *glace de viande*.' And this opens up to the uninitiated a vista as wide as the backgrounds of Leonardo da Vinci, the infinite whereof remains amystery still to the profane. Imagination is wanting in the female cook; and therefore does no woman ever make a *jus*. She stops at the soup and the *bouilli*. But, if your purse permits, you must sacrifice both of these to make a *jus*, or that *glace de viande* for which Dumas would accept no substitute. When twelve or fourteen quarts of water are reduced to half, and the entire ingredients are taken away, then begins the 'reduction,' in good earnest, and from the remaining essence you obtain your *fond de jus*."

GLAZING CAKES—Means to make them shine by either egging, or egging and sugaring the tops, or by brushing over with milk, or by covering with sugar and water icing.

## GON

GLUCOSE—Grape sugar or the kind of sugar that will not granulate. The recent discoveries of methods of making it abundantly have had a great effect upon the confectionery trade, glucose being but about half the price of sugar, and consequently a cheapener of candies, syrups, jellies, and numerous other compounds. One, perhaps the principal method of producing glucose is by treating corn meal with sulphuric acid, which changes the corn to a sweet gum. In the great corn-producing regions there are immense buildings erected especially, one in Chicago being nine stories in height, an entire block of brick. Glucose is as wholesome as any other syrup. In appearance it is like the white syrup known as silver drips, but is too thick to run; can be taken up on a pallet knife like the thickest molasses in cold weather; is as clear as glass. It comes in another form, however, in barrels, when it is lumpy like gum and syrup mixed, when it is at the nearest approach to being sugar. It costs about an average of four cents a pound. GLUCOSE IN ICE CREAM—One good use of it is to sweeten ice cream, the effect when the cream is well worked is to make it very smooth and soft to the palate. IN CANDIES—It is used with about twice its weight of sugar in making gum-drops and all that class of goods, and in imitation fruit-jellies, maple syrups and cheapening devices of many descriptions. GLUCOSE IN BREAD—"The bakers are endeavoring to make first-quality bread out of low-grade flour. A successful attempt in this line is reported as having been made by a Swiss baker, who mixes glucose, or starch-sugar, with low-grade flour, and is thereby enabled to turn out a loaf which closely resembles the product of high-grade flours, at a lessened cost." GLUCOSE IN SUGAR BOILING—It has the same effect to prevent sugar going to grains again as acids have. GLUCOSE IN CREAM CRACKERS—Is said to have a very decided effect in improving the quality of sweet crackers, especially in giving a smooth appearance and fine color. GLUCOSE IN SODA SYRUPS—This is one of the principal uses of it; the syrups are foamy, smooth and delicious when made with glucose. GLUCOSE IN TOBACCO—It is added to chewing tobacco instead of molasses, and in larger proportion, as it increases the weight of the tobacco to an extent very profitable to the makers.

GODARD GARNISH—Slices of sweetbreads and truffles, heads of mushrooms, quenelles and quartered artichokes with brown sauce. ALOYAU DE BŒUF A LA GODARD—Sirloin of beef baked in wine, tomato sauce, etc., served with godard garnishing.

GODIVEAU (Fr.)—Veal forcemeat; white veal with cooked udder, bacon or suet pounded to a fine paste; variously mixed with eggs, cream, bread, etc., to make forcemeat balls, quenelles, meat-pie linings and garnishes.

GONDINGO—Florida-Spanish name of a thick soup made of liver and giblets, onions, green peppers, and rice.

## GOO

GOOBER OR GUBER PEA—Southern popular name for the pea-nut or ground nut.

GORGONZOLA—One of the present favorite dinner cheeses, said to have largely displaced English Stilton. It is an Italian cheese; can be found at most of the fancy groceries or wine and oil importing houses. **TO KEEP GORGONZOLA CHEESE**—Cover it thoroughly with well-buttered white paper, so as effectually to exclude the air; then wrap it in brown paper. It should be looked at from time to time, and fresh buttered paper put on. It should be kept in a cool dry place.

GOOSE — “A dinner was given one day not long ago to William M. Evarts, the American lawyer, who is a great epicure. One of the courses, roast stuffed goose, seemed especially to please the palate of the learned gentleman, and he lent himself thereto with much vigor. After dinner came speeches, and in the course of one of them a gentleman asked this conundrum: ‘What great change has taken place during this dinner?’ It was given up. He had to answer his own conundrum—‘When we began, we had a goose stuffed with sage; now we have finished, we have a sage stuffed with goose.’” **GOOSE WITH SAGE AND ONIONS**—“Sage and onions are the traditional concomitants of the seasoning. It is that which Queen Elizabeth favored when she made a goose at Michaelmas, the fashionable dish of her age, and a national dish for many ages to come. It was sage and onions Old Dr. Parr of ‘Life Pill’ fame delighted to revel in. It was the savory smell that made him squeeze his friend’s hand (when he descended to the vicar’s modest parlor after changing his rain-besoaked clothing and awaiting dinner), as he exclaimed: ‘How kind of *you*, my dear friend, when you know I’m tho fond of roath goothe,’ and it was only the poor doctor’s horse-hair wig and some onion peelings behind the fire. The dinner was shoulder of mutton and onion sauce.” **GREEN GOOSE**—“A plump little green-goose is considered by epicures to be the daintiest of morsels; but the young stubble or autumn goose of 5 or 6 months old is most appreciated by the general public and the caterer. Its flavor is more developed, there is more of it to carve at, it is not so strong as its elder brethren either in flavor or sinew.” Green-goose is in season from April till July, or until it is 3 months old. In preparing it for roasting, it is generally dipped in boiling water, which has the effect of opening the pores of the skin, and permitting the removal of the feathers without breaking it. The bird is then drawn and prepared for roasting. **THE STUBBLE-GOOSE**—Is properly 5 to 7 months old. It is picked in the usual way that all poultry are relieved of their feathers. The head is removed, leaving the neck attached to it, and so cut that about 2 inches of the skin that covers the neck is left on the body. The bird is emptied in the usual way, and the feet cut off. It is then wiped out. Green-geese should not be stuffed. Stubble-geese may be, espec-

## GOO

ially when they are served as “Michaelmas-geese.” **FIVE GEESE**—“Madame Guiccioli said of Byron, that he insisted upon keeping up old customs in small things, such as having hot cross buns on Good Friday and roast goose on Michaelmas Day. This last fancy led to a grotesque result. After buying a goose and fearing it might be too lean, he fed it every day for a month previously, so that the poet and the bird became so mutually attached that when September 29 arrived he could not kill it, but bought another, and had the pet goose swung in a cage under his carriage when he traveled, so that after four years he was moving about with four geese. **GOOSE AND SWAN**—It is a curious illustration of the *de gustibus non est disputandum*, that the ancients considered the swan as a high delicacy and abstained from the flesh of the goose as impure and indigestible. **TOULOUSE SALE D’OIE**—In the Toulouse district, famous for its geese, those birds are never roasted or baked, being for the most part treated as follows: They are cut into pieces and put on a good fire in a copper vessel with a proper addition of salt. When cooked they are laid in pots and covered with fat. This is called *sale d’oie*, or salted goose, and is found in every house in the district. **GOOSE DINNER**—In a dinner made up principally of the bird, which is—or was in the days of James and Horace Smith—“uncommon common on a common”: “Dish No. 2, if not exactly a mystery, was at least a gastronomic revelation to those who had never tasted a goose stuffed with truffles and olives two days before cooking, then roasted and served with rich brown gravy and potato straws. The third dish was simply a boiled goose served with the accompaniments of pickled pork, celery sauce and vegetables. The fourth dish brought to light a roast goose stuffed with chestnuts and apples (in the German fashion), and eaten with brown gravy and sauté potatoes. The fifth and last dish was also a roast goose, with a savory lining of veal stuffing served with rich gravy, peas *a la Francaise*, and mashed potatoes. By the time justice had been done to this repast, the cry went round, ‘not too much goose, but just goose enough.’” **ROAST GOOSE**—Sage and onion stuffing is the general accompaniment of roast goose. If a strong flavor of onion is liked, the onions should be chopped raw; if this is not the case, they should be boiled in one, two or three waters, and mixed with a large or small quantity of bread-crumbs. Truss the goose firmly, tie the openings securely, place it in a deep pan with water enough to prevent burning, and a little drippings, cover with a buttered paper; baste continuously until done. A goose is both unwholesome and unpalatable if insufficiently cooked. When done, take it up, remove the skewers and fastenings, pour gravy round it and send apple sauce to table with it. The time required to cook a medium-sized goose is from one hour to one hour and a half. **BRAISED GOOSE A L’ALSACIENNE**—Stuffed with pork sausage meat extra high

## GOO

seasoned and mixed with bread-crumbs; braised in covered vessel with white wine and broth, and aromatics; served with broiled sausages, boiled chestnuts in bouillon, and balls of potatoes fried, and gravy made of the braise liquor. **GOOSE LIVER**—Goose liver or *foie gras* is extensively used in sandwiches. Cut it into thin slices, place them between slices of buttered bread, add a little French mustard, a drop or two of lemon juice, and serve. **ROAST GOOSE A LA MOUNT VERNON**—Young goose stuffed with mashed potatoes, which contain a slight seasoning of lightly fried onions. Apples in halves, pared, baked in goose-grease and little sugar, served with the roasted goose. **GOOSE A L'ARLESIENNE**—Goose stuffed with forcemeat made of onions, chestnuts, bread, parsley and seasonings. Braised in stock with aromatics for 2 hours; served with tomato sauce made of the braise liquor and drained tomatoes. **GOOSE PIE**—Is made like game pie or pâté, to cut cold, or cut up; half-fried, then stewed and covered with paste and baked. **GEESE IN EGYPT**—The Egyptians served geese at their meals every day; it was, with veal, the favorite dish of their monarchs, and they did not forget to offer some to King Agesilaus when he was traveling through the country.

**GOOSEBERRY**—A fruit of but little consequence in the United States; most congenial to cool and moist climates; very prominent among English fruits. **GOOSEBERRY CHAMPAGNE**—A good trade is being done in the district of Hedemarken, in Norway, in gooseberry champagne. It is a well-known fact that more champagne is drunk every year in America alone than is produced in the province from which the wine takes its name. Of course, a large quantity is genuine champagne, but a still larger quantity is made up from cider, gooseberry and rhubarb juice. This gooseberry champagne is remarkably good, and is fast gaining favor in Sweden and the United States; but beer is much preferred by the Norwegians. Made by mashing 40 lbs. of ripe berries in a tub with 4 gallons water, lukewarm; left to steep a day, pulped through a sieve; 30 lbs. sugar added and water to make up 11 gals. Add 3 oz. crude tartar, let ferment itself in warm place 2 days, drawn off into 10 gal. keg and stoppered when fermentation ceases, or in 10 or 12 days; is bottled 6 months afterwards. **GOOSEBERRY PICKLE**—A very favorite pickle in some parts of France is gooseberries preserved in vinegar. The variety usually pickled is the small red one, pickled before maturity. This pickle suits some people amazingly, but as to me, my teeth are on edge with no likelihood of getting off, by merely writing these lines. **GOOSEBERRY SOUFFLE**—Gooseberry pulp, well sweetened in the stewing, placed in a glass dish, yolk custard poured over, whipped whites on top; cold. **GOOSEBERRY FOOL**—English institution; stewed green gooseberries with sugar and milk or cream, or milk mixed in and whipped cream on top. **GOOSEBERRY SAUCE**—Same way as apple sauce,

## GRA

eaten with roast goose and pork. **TARTS DE GROSEILLES VERTES**—Green gooseberry open pies. **POUDING AUX GROSEILLES**—A gooseberry cream pie, made of purée of gooseberries, bread-crumbs, butter, eggs and sugar. **GOOSEBERRY MARASCHINO**—An imitation, like gooseberry champagne; made of 25 lbs. of best red ripe gooseberries and 5 lbs. wild cherries and cherry leaves, all bruised and steeped in 1 gal. gin for two weeks. Filtered through a jelly bag, 3 pts. clear white sugar-syrup added; bottled.

**GOUJON (Fr.)**—Gudgeon; a small river fish.

**GOURMET AND GOURMAND**—“There are two broad varieties in French lovers of eating—the *gourmets* and the *gourmands*. The difference between them is so great that they may be considered as complete opposites. The *gourmand* is a mere glutton, who eats as much as he can, devouring one dish after another. The *gourmand* is the man who omits not one of the dishes at a *table-d'hôte*, and then complains that he cannot dine properly in that hotel. The *gourmet*, on the contrary, is a product of high civilization. He enjoys with discrimination, and he is quite on the side of temperance; he even values the commonest things, if they are excellent of their own kind. A French *gourmet* once said to me, ‘I am excessively fond of oysters; but I never exceed one dozen, being convinced that after the first dozen the palate has become incapable of fully appreciating the flavor.’ A real *gourmet* preserves his palate in the healthiest and most natural condition; he prefers the simplest meal, such as fried mutton chop, if it is really well cooked, to an elaborate banquet where the cookery is less than excellent.

“But a plain leg of mutton, my Lucy,  
I Pr’ythee get ready at three:  
Have it smoking, and tender, and juicy,  
And what better meat can there be?”

I knew a Parisian who was a *gourmet* in Thackeray’s manner, and his way of living was to order one dish of meat, one of vegetables, and a little dessert, at an excellent and expensive *restaurant a la carte*. He did not desire the more abundant feeding at the *restaurantes a prix fixe* and the *tables-d’hôte*. He drank very moderately also; in a word, he lived as a gentleman ought to live, without excess, yet with perfect appreciation.”

**GOUT (Fr.)**—Taste; flavor. **GOUTEZ LA!**—Taste it! **HAUT-GOUT**—High-flavor.

**GRAHAM**—Name of a Boston physician who zealously advocated the use of unbolted wheat-meal for bread instead of fine flour, hence the name of Graham flour, bread, farina, etc., all made of whole meal.

**GRANITO (It.)**—Iced punch of various sorts. (See *Ices*.)

**GRAPES**—Among the best of fruits to serve for breakfast and always welcome at dinner. The Concord grape is the staple variety available in this

## GRA

country, and taking it altogether it is the best, for while there are others more delicate in flavor and more attractive in color, there are none so evenly ripe, so juicy, so sweet, so good to last through several months, so reliable and unfailing. **MUSCADDINE**—A Southern native grape of high musky flavor. **SCUPPERNONG**—A large, coarse Southern native grape, good for wine; comes to market without stems, like baskets of plums; is dull-yellow or olive-colored. **MALAGA GRAPES**—Imported in kegs, packed in sawdust; cost about twice as much as native grapes; firm, green, sweet; the kind to buy for party suppers and for dessert in winter and spring. **GRAPE ICE CREAM**—White California grapes, Muscats, Tokays, are suitable to mix in ice cream whole, uncooked, after the freezing is nearly completed. **GRAPE WATER ICE**—Any kind of grapes pressed and the juice strained, sweetened, frozen. **GRAPE JELLY**—Stewed grapes, the juice strained off and boiled down thick with sugar. **GRAPE TABLE JELLY**—White grape juice strained, sweetened, wine added, and 1½ oz. gelatine in each quart, boiled; cooled in moulds with layers of raw grapes. **GRAPE PIES**, tarts, jams, marmalade, preserves, etc., same as other fruit. **PICKLED GRAPES**—Ripe grapes pickled in vinegar, though their merits are well known in Southern Russia, have never received due recognition in England. But these are delicacies rather than food. **GRAPES FOR DESSERT**—At lunches, buffets, and five-o'clocks in France, strawberries, and indeed most berries, are eaten with champagne. Muscatel grapes powdered with crushed ices and anointed with sparkling wine are a favorite dessert-dish. Grapes are invariably eaten with wine in France, the bunch being dipped into the wine. Red grapes are eaten with red wine, and white grapes with white wine.

**GRAPES TO KEEP**—Packing in dry sawdust, or hanging by single bunches on lines in a cool dry basement-room are the most effective ways. **GRAPE WINE**—Home-made grape wine is made in localities where grapes abound by the same method as cider; it ferments itself, and when that is nearly over it is drawn off into a sulphur-smoked barrel, a gallon or two of native spirit added, such as apple or peach brandy or corn whiskey, and the barrel is tightly closed and stored away.

**GRAPE FRUIT**—Name of a large sort of orange, acid but with a grape-like flavor, common in Florida and the West Indies and plentiful in Southern markets; the shaddock.

**GRAVY SOUP**—English name for rich beef soup.

**GRAVY BEEF**—Rough cuts only fit for stewing.

**GRAYLING**—A fresh water fish found in the great lakes and rivers, also as mentioned by Izaak Walton, in English rivers, silver scaled, weight from 1 to 5 pounds.

**GREEK COOKERY**—**LIQUEURS**—It is usual in Greece to drink liqueurs *before* dinner. The Greeks

## GRE

drink liqueurs and not spirits straight. *Raki* is the liqueur preferred, and that made in Cluos is considered the best. Absinthe, chartreuse, maraschino and the other liqueurs almost universally employed are equally acceptable and proper at a Greek dinner. **SOUP**—All Greek dinners begin with soup and not with *hors d'œuvres*, which come afterwards.—**MUTTON SOUP A LA GREQUE**—A boned shoulder of mutton cooked in mutton broth, taken up and cut in dice; carrots, turnips and onions also cut in squares and cooked in broth, and green peas added to them; purée of split-peas made separately; then all mixed together, mutton, vegetables and purée of peas to make the soup. **VERMICELLI SOUP A LA GREQUE**—A cream-colored soup with vermicelli; made of consommé slightly thickened with flour and butter roux; after boiling poured to 2 yolks to each quart, and ½ cup cream; hot enough to thicken, but not boil; vermicelli cooked separately and added to the soup. **POTAGE MARATHION**—Broth with rice and fresh tomatoes, *i. e.*, rice and tomato soup made with mutton stock; parsley to finish. **POTAGE SALAMIS**—Yellow, smooth, egg-and-acid soup made of consommé with 2 yolks and juice of 1 lemon to each qt.; the juice beaten into the yolks, and boiling consommé poured to them; made hot enough to thicken like cream, but must not boil; cayenne and parsley. **THE SOUP-MEAT WITH GREENS**—At all Greek dinners the mutton, beef, or poultry, out of which the soup has been prepared, is always served after the soup. This is a national habit and not a matter of economy; this meat is usually eaten with greens, dandelion leaves or other mild herbs. **GREEK HORS D'ŒUVRES**—It is with the boiled meat that the *hors d'œuvres* are served in Greece, never before. **OLIVES**—Ripe black olives in oil, green olives in great variety, and pickled peppers. **CAVIARO-SALATA**—Made of ⅓ caviare, ⅓ almonds rolled to powder, ⅓ bread-crumbs; olive oil to moisten, lemon juice, cayenne; spread on small, thick slices of bread. **LAKERDA**—Smoked and salted fish; considered a great delicacy. **ARZOTARACHIO**—The roe of the gray mullet pressed and dried. **TSIRAS**—A salad of anchovies, olives and parsley. It is usual in Greece to leave the *hors d'œuvres* on the table during the whole meal until dessert is served. **GREEK FISH**—Amongst the abundance of the Mediterranean fish the red mullet is perhaps the favorite. It is cooked in oil with garlic, parsley and cayenne, or baked in tomato sauce with lemon juice. Gray mullet, brill and sea-bream are also much eaten. Another favorite way of cooking fish is to fry them in oil, adding butter and vinegar, rosemary, garlic, and capers to the oil they are fried in, allowing them to get cold in the dressing; they are eaten either cold or hot. **GREEK VEGETABLES**—Stuffed artichokes, stuffed tomatoes, stuffed cucumbers, egg plant and vegetable marrows. **FILLET OF BEEF A L'ATHENIENNE**—In the Athens style it is larded, roasted or baked, surrounded with fried egg-plant in thick slices, a brown sauce with Ma-

## GRE

deira poured over the fillet. **BEEFSTEAK A LA GREQUE**—Beefsteaks lightly fried with onions, a gill of Marsala wine,  $\frac{1}{2}$  pt. espagnole, same of stewed tomatoes added, simmered an hour; served with fried egg plant. **GREEK CHICKEN**—Cut up and cooked in tomato sauce and white wine, similar to beefsteak *a la Greque*. **GREEK ROAST LAMB**—The favorite roast is very young lamb. **AGNEAU KLEFTIKO**—A whole lamb roasted before an open wood fire, adding wild thyme and lemon juice to the basting; served with salads and vegetables. This dish is always eaten at Easter in Greece. **POMMES KERTEDES**—Potato croquettes flavored with grated cheese. **STUFFED CUCUMBERS A LA GREQUE**—Pieces 2 inches long parboiled, center hollowed out, set on end, filled with raw mutton forcemeat, simmered in the oven; served with tomato sauce. **GREEK PILAF**—Rice boiled in broth with tomatoes and butter. The rice should be neither dry nor floating in liquid—a happy medium between the two. *Pilaf* is very good with larks, pieces of chicken or any kind of meat; it can also be eaten alone. “A few years ago some Greek students in Paris, longing for the flesh-pots of Hellas, got a Greek cook to come over to cook for them. He hired a small shop and began on the lowest possible scale. He has now one of the most successful restaurants in the Latin quarter and does a splendid trade, of which anyone may convince himself by looking into the *Restaurant Orientale* in the Rue des Ecoles. He is specially noted for his *pilaf*.” **GREEK BUTTERED RICE**—A cupful of rice, raw, is fried in butter; a pint of tomato soup, or broth and tomatoes, is poured to the rice and all boiled about 20 minutes. It should not be very liquid, but dry enough to heap up in a dish. Have butter stirred in before serving. It is but a slight variation of *pilaf*; is served with broiled chicken livers, roasted larks, or vegetables only, such as cauliflower branches *au gratin*. **GREEK RICE PUDDING**—Cinnamon-flavored boiled rice custard, served with ground cinnamon separately. Made of 4 oz. rice, 2 qts. milk, 8 yolks, 2 oz. corn starch, 8 oz. sugar, 1 oz. cinnamon. Rice boiled in milk with cinnamon, custard made separately, stirred together; served cold. **GREEK PUDDING**—Thick slices of bread soaked in cold milk, then strained and fried in oil or clear butter till browned outside only. Saturated with honey-and-sugar syrup, flavored with cinnamon; served warm. Rice and milk with sugar and cinnamon are made up in various forms of Greek sweet dishes. **GREEK BALAKLAVA CAKE**—Layers of pastry spread with chopped almonds in honey. **CONRABIES**—Thin wafers made of flour, sugar, and butter; baked until crisp. (*See Fairy Gingerbread, the ginger omitted or substituted.*) **RHÉLO SACCIIAREE**—See *Crystallized Rose Leaves*. **SERBATI-GLUKO**—Preserves scented with flowers. **GREEK DESSERT**—There are usually piles of many-colored grapes, oranges, sweet lemons, pomegranates, etc. The pomegranates are usually cut in halves, and

## GRI

eaten with powdered sugar and orange-flower water. **GREEK WINES**—The white wines of Patros, Samos and Cephalonia, and the red wines called *rezinato* because of the rosin which is added to the wines to preserve them. With dessert the Cyprus wine known as *Commanderia* (thick and strong like thick syrup) is drunk. Sweet port would make a very good substitute for *Commanderia*; Bordeaux, red or white, makes a good substitute for Patros wine, and various burgundies for *rezinato*.

**GREENGAGE**—An excellent plum which remains green when ripe. Cooked and used in all the ways suitable for apricots; acceptable for contrast of colors in compotes, jams, jellies and ices.

**GREEN ANCHOVY BUTTER**—For fish, chopped parsley leaves, the juice squeezed through a napkin by twisting, mixed with anchovies and butter, pounded and put through a sieve. Must be lukewarm to mix, then made cold.

**GREEN SAUCE**—Bignon's *sauce vert*. Used as mint sauce with roast lamb and cold meats; made of equal quantities of capers, parsley, chives, gherkins, and tarragon. Mince the whole very fine, and mix it all together. Then season with pepper and salt and cayenne, and put it into a jar with tarragon vinegar. When it is wanted to serve, take as much as is required; put it into a bowl with a sufficient quantity of chervil, a little French mustard and the necessary amount of salad-oil.

**GREEN GOOSE**—Spring goose. (*See Goose.*)

**GRENADINS**—Thin slices of veal and some other meats larded. **GRENADINS DE FILET DE BŒUF A LA FINANCIERE**—Thin slices of tenderloin, larded, cooked in *murepoix* or seasoned stock, served in the reduced sauce with *Financiere* garnish. **GRENADINS DE VEAU AUX PETITES RACINES**—Thin oval slices of veal larded with strips of fat pork, braised in a pan with aromatics, glazed in their own sauce, served with potatoes, carrots and turnips half fried, then stewed in brown sauce. **GRENADINS DE VEAU, SAUCE TOMATE**—Served with tomato sauce.

**GRILL**—Gridiron; broiler; a grill; a broil.

**GRILL-ROOM**—English public kitchen where meats are broiled to order; sometimes on a silver gridiron and in sight of the customer.

**GRIMOD DE LA REYNIERE**—A name attached to several modern French dishes, has reference to a notable patron of culinary art, contemporary with De Cussy, Carême, and Brillat-Savarin: “Grimond de la Reyniere came of a banking family, and no one had a bad word to say against either his palate or his camel. An accident in early childhood deprived him of both hands, which he replaced by many ingenious contrivances; and he even became a dandy in his youth, frequented the leaders of the *Français*, and visited Voltaire. He was muscularly strong, and had a strong constitution; eventually developed, let us say, a hump on his camel, *i. e.* became obese and



## GRI

lived to be eighty. He was a charming talker in his best years, but latterly, wrote De Cussy, he got to be commonplace and garrulous about everything. The same Dr. Roques, exclaiming *quantum mutatus*, said in a sketch of Grimod's old age that 'he rang for his servants at nine in the morning, shouting and scolding until he got his vermicelli soup. Soon after he became tranquil, and began to talk gaily; finally becoming silent, and going to sleep again for some hours. At his waking the complaints began over again; he would fly into rages, groan, weep, and wish he was dead. But, when dinner-time came, he ate of every dish, all the time declaring that he would have nothing, for his end was nigh. At dessert his face began to show some animation, his eyebrows lifted, and some light showed from the eyes, deep sunk in their sockets. 'How is De Cussy? Will he live long?' he would ask; 'they say he has a fatal ailment. They haven't put him on diet yet, have they? The rains were heavy; we'll have lots of mushrooms in the autumn. The vines are splendid; you must come for the vintage;' and so on, always about gluttony. Then he would grow gradually silent in his great armchair, and the eyes would close. At ten they came for him—he could no longer walk—and put him to bed.' And this was the youngster who, at the age of twenty, was caught by his own father sitting down, lone as the ace of spades, to seven roast turkeys, merely for their "oysters," their *sot-l'y-laisse*, as the French say." (Note.—The "oysters" are the tid-bits of meat on each side of the small of the back. But another one who tells the anecdote says the seven turkeys were ordered merely for their "Pope's nose.")

**TURKEY A LA REYNIERE**—A plump, fat and tender turkey-hen is trussed nicely and roasted about an hour and a quarter; untrussed, placed on a dish, surrounded with sausages and chestnuts and cress at each end; served with a slightly thickened gravy into which the liver of the turkey previously cooked and sliced fine, is put at the last moment.

**ROAST WOODCOCK A LA GRIMOD**—The birds skewered with their bills, the trail chopped on toast, birds roasted before the fire with the prepared toast beneath to receive the drippings. Served on the toast with gravy and quartered lemons.

**SALAD A LA GRIMOD**—Several vegetables parboiled and chopped, arranged on toasted bread in separate groups with chopped yolks and whites, oil, vinegar, etc.

**GRISSINI BREAD**—"A Boston paper says that the technical name for those long sticks of bread, such as are served at the Parker House, which one finds it so entertaining to nibble upon between courses, is Grissini, the patronymic of the Turin baker who invented them." A London paper says: "Italian Grissini has deservedly come into high favor for soups, etc., and the crisp finger-like article produced by Messrs. Grinnell has already created a large demand, so much so that it is now said to be 'the rage.'" — "You may in many cases learn from

## GRO

your hotel bills the chief products of places in the way of food; for, of course, I had sausages at Bologna, 'grissini' at Turin, grapes at Tyrol, and so on; while as for wine you may instruct yourself as to the native soil of many dozen varieties." Mr. T. J. Harrison, a baker in business at one period, made a specialty of grissini in Detroit. He took in a destitute Italian baker who in turn showed his employer what he could do, and thus the grissini trade was started to their mutual profit, the Italian residents being pretty constant buyers from the first. The Italian baker would call it Garibaldi Grissini in the advertisements when he had his way; but it seemed there were two political parties among the Italians, and one-half of them would not buy Garibaldi bread; consequently the bread took on a strictly neutral character after that was discovered, and became Italian grissini, neither more nor less. It is made of the ordinary bread-dough with some butter worked into it; then the dough is kneaded under a lever-break as if for crackers. Made into rolls about two fingers thick, allowed to rise, brushed over with water, divided and taken up one by one by the ends and pulled out to the thinness of a little finger and about 12 inches long; then rolled, wet as they are, in corn meal, placed on a wet peel and slid off when the peel is full on to the oven bottom. A revolving oven is the best for them as they need but a few minutes to bake. Sold at 60c. per lb. Being almost hollow, nearly all crust, it takes a stack of them to weigh a pound.

**GRISKIN OF PORK**—The loin; the roasting piece between the last rib and the ham-joint; same as the porter-house cut of beef.



GROSSE PIERCE SUR SOCLE.

Round of spiced beef on carved stand of mutton fat.

**GROG**—"A drink composed of rum and something else was called 'grog.' It originally meant rum diluted with water, but was more often with a cordial or something of that nature. The name of 'grog'

## GRO

was derived in a singular way. It is said that once Admiral Vernon, in the British navy, and who was noted for his generous nature, was wont to deal out an allowance of this drink to his sailors. He wore what was called a 'grogan' cloak in severe weather, and after a while the men jestingly designated him as 'old grog,' hence the name of the mixture."

GRONDIN (Fr.)—Gurnet or gurnard; a fish.

GROSSES PIECES (Fr.)—Large ornamented pieces; built up dishes; pyramids; designs in cooked meats; ornamental sugar work on stands.

GROSEILLES (Fr.)—Garden currants; *cassis*—black currants (garden). Zante currants are *raisins de corinthe*. GROSEILLES VERTES—Gooseberries.

GROUND RICE—Used like farina, starch, tapioca and sago in all sorts of puddings and custards.

GROUND-NUT—The peanut.

GROUPER—A fish of the Florida and Gulf coast. There are three varieties, known as red, black and white grouper; the shape is like a carp, the scales and color more like black bass; size from 5 to 15 lbs.; flesh second quality, being rather hard and coarse in comparison with the red-snapper, which is abundant in the same localities. Is cooked in the same ways as snapper, and baked in tomato sauce, and the southern *courtbouillon*.

GROUSE — Prairie chickens; spruce grouse, ruffed grouse, pin-tail grouse, moor-fowl, and other kinds; larger than a partridge. GROUSE A LA ROB ROY—Alexis Soyer, the famous Reform Club *chef*, bestowed much attention on the cooking of grouse. One of his modes was to wrap the bird to be roasted in slices of fat bacon and sprigs of heather well steeped in whisky. This is "grouse *a la Rob Roy*." GROUSE A LA RUSSE—After roasting the birds, cut them up into joints, arrange in a pyramid on a dish, and cover over with meat glaze; hand rich gravy in a sauce-boat. GROUSE A L'ECOSSAISE — Scotch style; the grouse roasted, then cut up; sauce made in the pan with the scraps, backs of grouse, etc., orange juice added; grouse piled up on toasted bread, sauce over all, orange slices around. GROUSE A LA FINANCIERE — Grouse stuffed with a forcemeat of the livers pounded with onion, mushrooms, bread-crumbs, butter, salt, pepper; roasted; served with brown sauce and mushrooms. MARINADED GROUSE—The grouse steeped in a pickle of vinegar, chopped onion, bay leaves, juniper berries, pepper corns, for 3 days. Stuffed with turkey stuffing, breasts larded, roasted with constant butter basting. Served with sliced lemons. GROUSE PUDDING—Birds cut up, a deep pudding bowl lined with short-paste, thin beefsteak at bottom, then chopped mushrooms, then pieces of grouse, peppered, salted and floured, so on till bowl is full; cupful of gravy added, paste cover, edges wetted and secured, tied down in cloth, boiled 3 or 4 hours. Served in bowl with folded napkin arranged around it, or served from sideboard. SOUFFLE OF GROUSE—Cold roast grouse meat pounded to a paste with 1 oz. butter, 2

## GUI

oz. cooked rice, aromatic salt,  $\frac{1}{4}$  pt. meat glaze; rubbed through a seive, 4 yolks added, lastly 4 whites whipped firm; baked in a mould. It rises light in the oven. Served in the mould soon as done, with gravy aside. SALMI OF MOOR FOWL—Cooked birds cut up into a stewpan with olive oil, lemon rind and juice, piece of orange peel, shallot, pepper, salt, cayenne, tossed up till hot through, served hot. GROUSE SOUP—Grouse boiled in meat stock, flesh picked off and pounded through seive; soup thickened with butter and flour, strained, 2 yolks added and the purée of grouse. Duchess crusts. GROUSE A LA AILSA—Grouse cut up, the joints dipped in thick essence of game sauce, then in bread-crumbs, then in egg and crumbs; browned in the oven in butter. SALMIS DE GROUSE AUX TRUFFES—Roasted, cut up, heated in essence of game sauce with truffles, garnished with croutons. GROUSE A LA COMMODORE—The joints coated with a forcemeat of grouse and dressed in a pyramid with rich game sauce. FILETS DE GROUSE A LA CHANCELIERE — Breasts of grouse dressed in a crown, with small quenelles of veal in the center, and game sauce. SALADE AUX GROUSES—The joints masked with a salmis sauce and aspic (*chaudfroid* sauce). Dressed on a salad with mayonnaise sauce, garnish with eggs, beets, etc. BROILED GROUSE ON TOAST—Split down the back, flattened with the cleaver, trimmed a little, salted and peppered, broiled rare; served on dry toast with *maitre d'hotel* butter, cress and lemons. GROUSE AU FUMET—Roasted grouse cut up from the bones; the bones broken and stewed in espagnole, with aromatics and sherry to make the sauce which is pressed through a napkin by twisting. Served on slices of fried bread with sauce over. GROUSE AU CHASSEUR — Grouse roasted, cut up, served with chasseur sauce made of 1 pt. espagnole,  $\frac{1}{2}$  pt. tomato sauce, shallots half fried in butter, few mushrooms, parsley, lemon juice. GROUSE WITH PRUNE SAUCE—Roasted grouse served with sauce made by stewing prunes in red wine and adding them to espagnole. (*See game, prairie hens.*)

GRUYERE—One of the French cheeses often named in cooking directions; next best to Parmesan for cooking purposes, and eaten at table. Not choice, only foreign.

GUANA—In Central America and the West Indies the great tree-lizards called guanas form a really important part of the food of the poorer people. They prepare it by cleaning and scraping it, then roasting it in a hole in the ground. "A more civilized fashion is a fricassée, with tomatoes and peppers *a la Creole*. The similarity of the white and tender flesh to chicken is noted by everybody, and there are few persons who do not find it highly toothsome. 'We caught more in the same way,' says an antiquated author, after an entertaining description of a guana hunt, 'and kept one alive seven or eight days; but it grieved me to the heart to find that he thereby lost much delicious fat.' The old writer was a monk, and spoke with feeling."

## GUA

**GUAVA**—A fruit of the West Indies and Florida; the tree is a species of myrtle, grows to a height of 20 feet. The fruit (about the size and shape of a fig) has an agreeable flavor, and is made into preserves and jelly. **GUAVA JELLY**—Possesses a peculiar fine flavor and very little acidity; it is more of a sweet-meat than a relish, yet is served both with meats and cakes.

**GUILLEMOTS**—The Normandy peasants make an excellent salmi from guillemots—the despised sea-crows of the Scotch—which is equal to woodcock, and superior to hare in flavor. Served with red wine, guillemot is a dish for a gourmet; but the people find the birds very good without such addition.

**GUINEA FOWL**—Is cooked as partridge, for which it occasionally serves as a substitute; is often sent to market in dressed lots mixed with chickens, but being darker fleshed should not be cooked with them; but is most excellent by its own name. It is the best substitute for game when game is out of season. It has two names in French. **PINTADE ROTI**—Roast Guinea fowl; the breast and legs larded, roasted under cover of buttered paper; served with cress in the dish, and brown gravy separately. Roast Guinea fowls are sometimes served with lettuce salad and apple fritters. **PINTADE A LA BERNARNAISE**—Guinea fowl roasted and served with Bernaise sauce. **GELINOTTE PIQUEE**—Larded Guinea hen. **GELINOTTE BARDEE**—Guinea hen wrapped in slices of fat pork, and baked.

**GUINEA PIG**—The cavy; a tame animal about the size of the opossum, kept as a pet by some people; good for food, and something like the opossum in taste. "F. Z. S. writes: I do not wish it to be supposed that I recommend the cavy as a cheap food, but rather for its delicious flavor and *recherche* quality. It may, no doubt, be sometimes grown at small expense, but I look upon it as being so valuable for the table as to make it worthy both of trouble and expense in its cultivation. Think of its value in the game course when game is out of season; of the value of its tender flesh and gelatinous skin in the feeding of invalids and convalescents, and of the vast number of ways in which a clever cook could utilize it. Probably there are few recipes for made dishes, either of rabbit or game, that would not be applicable to cavy. I consider the smooth-haired white cavy the best adapted for the table, on account of the whiteness of its skin."

**GULL**—There are many of the commoner kinds of sea-gulls that taste delicious in a pie when properly cooked. It is only prejudice that keeps people from eating them.

**GUMBO FILE** (Creole-Fr.)—Dried gumbo.

**GUMBO SOUP**—A specialty of the southern states; creole dish; soup thickened and flavored with okra or gumbo, either in its green state or dried and powdered. **CHICKEN GUMBO A LA CREOLE**—Pieces of chicken fried in butter with chopped onion and

## GUM

little ham; when fried light brown, some flour stirred in, and broth by degrees; bunch of parsley, salt, white pepper, sweet chili pepper; to each quart a heaping tablespoonful of gumbo powder dredged in carefully to avoid lumps; and taken from fire at once. Served with boiled rice separately. **OYSTER GUMBO**—Started by frying onion and salt pork in butter; flour added, little white wine, broth, water, peppers, parsley, thyme, oysters, and liquor; gumbo powder to thicken; served with rice. **CRAB GUMBO**—Same general method with crabs cut in pieces; soft-shell crabs preferred; served with rice. **SHRIMP GUMBO**—Large shrimps husked from their coats, fried with onions and salt pork in butter; flour, broth, white wine, water, parsley, green pepper, salt; gumbo powder to thicken; not boiled after gumbo is in; served with boiled rice.

**GUM**—Four or five kinds of gum are used in confectionery and syrups. **GUM SYRUP**—The Frenchman who asks for absinthe in your establishment probably asks for *gomme*. This means that he wants about half his lotion to consist of *sirop de gomme*. Now sirop de gomme, or gum arabic syrup, is not generally procurable and I want to tell you how to make it for yourself. **FRENCH WEIGHTS AND MEASURES**—Wash 500 grammes (1 lb. 1 3-5 oz.) of white gum-arabic. Dissolve it in a covered jar in a pint of cold water, stirring it frequently; then strain it through a linen strainer. Dissolve 2 kilos of sugar (4 lb. 6½ oz) in 2 litres of lukewarm water (3½ pints); place the bowl containing the liquefied sugar on the fire, skim carefully, and let it cook for about three minutes; then add the liquid gum, and let the mixture boil until about the consistency of strong liquid gum. Cool and bottle. **GUM ARABIC**—Since the war in the Soudan gum arabic has been very scarce; and the Germans in America are turning their attention to provide a substitute. The latest is the following: Twenty parts of powdered sugar are boiled with seven parts of fresh milk, and this is then mixed with fifty parts of a 36 per cent. solution of silicate of sodium, the mixture being then cooled at 122 Fahr., and poured into tin boxes, where granular masses will gradually separate out, which look very much like pieces of gum arabic. This artificial gum copiously and instantly reduces Fehling's solution, so that if mixed with powdered gum arabic as an adulterant its presence could be easily detected. **GUM DROPS**—A confection made of gum and sugar; also of glucose, dextrine and sugar. **COMMON GUM DROPS**—Made of 50 lbs. sugar, 25 lbs. glucose, 9 lbs. starch, 1 oz. each cream tartar and tartaric acid. Starch mixed with water till like cream; sugar made into syrup of 33 degrees, and when boiling, starch stirred into it; glucose then added; boiled 3½ hours; acid added, and flavor. Run into starch moulds, dried in a hot closet 2 days, tossed in granulated sugar. (*See Fig Paste.*) **GUM BENZOIN**—Gum from an East Indian tree; used, dissolved in alcohol, to varnish chocolate candies of all sorts to make them glossy. **GUM TRAGACANTH**—

## GUM

A gum which dissolves slowly in water and becomes like flour paste; is used mixed with sugar to make white ornaments for bride's cakes. **GUM DRAGON**—Another name for tragacanth. **GUM PASTE**—For cake-ornaments; made by putting 4 oz. white gum tragacanth in a bowl with 1 pt. warm water to soak for 24 hours, or until it is all dissolved; then forced through a towel by twisting. The gum is then rubbed with the hand on a marble slab for 10 minutes; fine powdered sugar added by degrees while the rubbing with the hand is continued until 3 lbs. sugar has been worked in and the paste is white and tough; to be kept in a jar till needed for use. If for making flowers, about 2 lbs. fine starch and  $\frac{1}{4}$  lb. sugar are worked into  $1\frac{1}{2}$  lb. of the stock mixture in the jar. If for pressing into moulds for leaf ornaments, 2 lbs. sugar and 1 lb. starch are worked into 2 lbs. of the jar stock; one drop of blue coloring to be mixed in. **GUM-PASTE FLOWERS**—Are made with the fingers and a set of small bone tools about the size of a piece of pencil adapted to form cups and hollows in the paste and to roll it to leaf-like thinness in the palm of the hand; a pair of scissors is used to cut the edges, and a toothpick stuck in a board to stick the flowers on to dry. Stamens are procured from the artificial millinery flower makers, and a little painting is done on the leaves. Roses are made by a leaf at a time rolled and shaped in starch in the palm of the hand and 20 or 30 of them fastened on a core or bud already dry on its stick. **GUM-PASTE LEAVES**—These and various patterns and designs are made by piping the design in cake-icing on oiled glass, bordering it with putty and making a mould from it by pouring on melted brimstone; this takes in the icing pattern, which can be dissolved out in water. Into this the gum paste is afterwards pressed, thus getting the icing pattern from the brimstone mould reproduced in gum paste. A piece of lace bobinet is stuck upon the back of the pattern before it is lifted.

**GUM FOR CHEWING**—The best is plain spruce gum as it exudes from the trees in Maine and Canada. Additions of sugar and flavoring are made; and adulterations with paraffine are practiced by different manufacturers, but there is no other standard but the plain gum conveniently wrapped for handling.

**GURNET OR GURNARD**—A sea-fish common in France and England. **GRONDIN FARCI AU FOUR**—Gurnet stuffed and baked. **FILETS DE GRONDINS EN MATELOTE**—Sides of gurnet breaded and fried; served with matelote sauce.

## H.

**HACHIS (Fr.)**—Hash. **HACHIS DE VENAISON**—Hashed venison.

**HADDOCK**—Well-known sea fish, nearly resembling the cod; of smaller size, however, and marked with black thumb spots on the shoulders, whence the legend that this is the fish which the

## HAL

apostle took up and found the penny in its mouth to pay the tribute to Caesar with; the mark of his fingers remains. **HADDOCK IN OLD ROME**—Pliny says: "The haddock, like the sturgeon, was surrounded with the ridiculous honors of an almost divine pomp. It was served interwoven with garlands, and trumpeters accompanied the slaves who, with uncovered heads and foreheads crowned with flowers, brought to the guests this dish, the merit of which was, perhaps, exaggerated by capricious fancies." **SCOTCH RIZZER'D HADDIE**—A fresh haddock cooked as follows: Rub the fish well inside and out with salt, hang it up by the head in the open air for twenty-four hours, skin it, dust it with flour, pepper and salt, and broil over a clear fire. **FILLETS OF HADDOCK**—Fresh haddock cut into strips, seasoned, rolled in flour, then in egg-and-cracker dust, fried, served with sauce and cut lemons. **SMOKED HADDOCK**—See *Finnan haddies*. **HADDOCK SOUFFLE**—Boiled salt haddock (like salt cod) pounded in a mortar, rubbed through a sieve; to  $\frac{1}{2}$  lb. of the fish purée 3 yolks are added, then the whites whipped to froth; the mixture is then baked in cases or cups; sent to table soon as done, while soft and light. **SMOKED HADDOCK SANDWICH**—Boiled smoked haddock picked from the bones and run through a sausage machine, mixed with  $\frac{1}{3}$  as much hot butter, cayenne, salt, anchovy essence added, spread on sandwiches. **MERLUCHE GRILLEE**—Broiled haddock. **MERLUCHE FARCIE**—Haddock stuffed and baked, served with brown sauce. **MERLUCHE SAUCE AUX ŒUFS**—Haddock boiled, with egg sauce. **MERLUCHE A LA HOLLANDAISE**—Boiled haddock with Hollandaise sauce.

**HAGGIS**—See *Scottish cookery*.

**HAKE**—Hake is an English "west-country" fish, often sold under the name of white salmon. It is a cheap fish and not very highly esteemed; cooked in same ways as halibut.

**HALIBUT**—Flat fish of the turbot family; reaches a very large size, sometimes weighing as much as 100 lbs. It is commonly cut into steaks. Halibut is sometimes offered for turbot, which is a dearer fish, but it may be distinguished by looking at the spots on the back, the halibut being without spots. **BOILED HALIBUT**—A thick cut boiled in water containing salt and vinegar, simmered 40 minutes; drained, served on a folded napkin, garnished with parsley; cream sauce in a bowl. **HALIBUT A LA CORDON BLEU**—Halibut steaks like larded grenadines of veal, but larded in colors with strips of anchovy, green peppers, lemon rind, and cel, simmered in wine stock, glazed with the reduced liquor; sauce and garnishings. **SCALLOPED HALIBUT AU PARMESAN**—Thin halibut steaks simmered in butter with onion, salt, pepper and nutmeg, then taken up and cream sauce made in the same saucepan, with yolks and grated cheese added; the fish placed in layers in a baking dish with sauce between and crumbs and grated cheese

## HAM

on top, and butter; baked brown. **CRIMPED HALIBUT**—Strips of halibut cut from the fish as soon as killed and immediately thrown into ice-water and allowed to remain for some time. This makes the fish firm and flakey. It is boiled in salted water, and served with caper or other fish sauce. **BAKED HALIBUT WITH CREAM**—A dish of picked halibut meat in cream sauce, with chopped mushrooms, bread-crumbed on top and browned. **FRIED HALIBUT, TOMATO SAUCE**—Slices dipped in milk, then in flour, fried light brown; sauce in a bowl. **HALIBUT PIE**—Same ways as eel pie and other pies. **HALIBUT A LA CHAMBORD**—Halibut steaks larded through and through with mushroom stalks cut in strips and shreds of cucumbers and anchovies; brushed over with lemon juice, let stand an hour or two. Then dipped in flour, cooked macaroni laid on in cross-bars; egged over the top, baked in buttered pan. Decorated with mushrooms, lemons, beets, parsley; thick brown sauce piquante.

**HAM**—“THE HAM FAIR—Every spring is held, on the Boulevard Richard Lenoir, at Paris, the ham fair, which fills the air with the odor of bacon. A double row of booths runs along the boulevard. Between bouquets of laurel are suspended cakes of dripping, sausages dry as marble, and smoked hams; large basins of lard stand about; smoked garlic-flavored sausages and other similar dainties are heaped up mountain high. Behind the exhibits are gathered whole families of country folk; the wife wears a large white apron, the husband walks about with knife in hand, inviting everybody to try his goods. The ham fair which has just been held is said to have been better supplied than it has been for years. Lyons and Ar'ès sent the finest specimens of pork, and Bayonne was, as usual, represented by its famous hams. Garlic sausages represented the town of Vire, and from the district of the Loire, from Italy and Switzerland, the products were excellent.”—

**STEAMED HAM**—Steaming is by far the best way of cooking a ham. Lay in cold water for 12 hours; wash very thoroughly, rubbing with a stiff brush to dislodge the salt and smoke on the outside. Put into a steamer, cover closely, and set it over a pot of boiling water. Allow at least 20 minutes to a pound. Keep the water at a hard boil. Spinach or some green vegetable should be served with it. **ROAST HAM**—Soak the ham for 12 hours in water, place it in a deep dish or earthenware pan, and soak for 24 hours in white wine, seasoned with sliced onions, carrots, parsley, laurel-leaves, and thyme; cover the pan with a cloth, and press on the lid very tight to prevent the air getting in. Roast the ham, baste with the wine in which it was soaked. When sufficiently done, dish it on a purée of spinach. **BOILED HAM**—“Brush the ham thoroughly with a dry brush, removing every particle of dust or mould. Soak for an hour in cold water, and then wash thoroughly. With a very sharp knife shave off cleanly the hardened surface from the face and butt of the ham. Put it over the fire in cold water and let it come to a

## HAM

moderate boil and keep it steadily at this point, allowing it to cook 20 minutes for every pound of meat. A ham weighing 12 lbs. will need to boil 4 hours. This time should never be cut short; on smaller hams it should rather be extended. The ham is to be served cold; allow the joint to remain in the pot after it is removed from the fire for several hours, until the water in which it has been cooked is cold. Then dish as before suggested.” After a ham has been simmered it is a great improvement to put it in a moderately warm oven, with a buttered paper over it, and bake for an hour. This is a Yorkshire custom, and a good one. **COOK-SHOP HAM**—At the ham-and-beef shops, which constitute one of the catering features of London, the following method of boiling hams is adopted with excellent results: The hams are always placed in cold water in a copper, under which a small fire is made, which raises the water very slowly to the boiling point. The moment this is accomplished the fire is raked out, the copper covered over, and the hams are allowed to remain in the water until it is nearly cold. By this means the flesh is rendered tender and juicy, and the loss of weight is guarded against. **PRIZE-HAM CURING**—The following is the method of curing hams that received the prize at a New England fair: To every hundred pounds of meat take eight pounds of salt, two ounces of saltpetre, two pounds brown sugar, and one and a quarter ounces potash and four gallons water. Mix them and pour the liquids over the hams after they have been in the tub two days, they having been rubbed with fine salt when put in the tub. They should remain in this pickle six weeks, then taken out, hung up three days to dry, and smoked. **FRIED HAM FOR BREAKFAST**—Is particularly nice when the slices are cut the night before and are allowed to soak all night in a cup of water into which a tablespoonful of sugar has been added. This softens the meat and removes excessive saltiness. **DEVILLED HAM**—Cut slices of cold ham, fry in their own fat, and when done arrange in a hot dish. Keep warm while you add to the gravy a teaspoonful of made mustard, a good pinch of pepper, a saltspoonful of white sugar, and three tabiespoonsful of vinegar. Mix these well together before stirring into the gravy; heat all to a sharp boil, pour over the ham, and let it stand, covered, for a minute before sending to the table. There is nothing more appetizing than this dish. **HAM COOKED IN CIDER**—Always cook a ham in cider when you can get it. Boil three hours and bake three, using also the cider to baste with. The apple seems the natural accompaniment of pork. Always scrub the ham well before boiling. **HAM GLACE, CHAMPAGNE SAUCE**—(1) A ham pared, and soaked for 24 hours in water containing a little vinegar, then covered up in a sheet of plain flour-and-water paste, and baked 4 hours; glazed, and served with champagne sauce. (2) A ham pared, soaked for 12 hours, boiled 1 hour, covered with a *mirepoix* or sauce consisting of fried onions and herbs moistened with wine, then inclosed in a sheet of

## HAM

plain paste, and baked 3 or 4 hours; glazed, and served with champagne sauce. **JAMBON D'YORK**—A Yorkshire ham, or ham served in Yorkshire style. It is pared, soaked for 12 hours in water, boiled an hour, the rind removed; roasted or baked 2 hours, glazed with the gravy and a dust of sugar, the hock pared, and a paper-ruffle put around the bone; served with Yorkshire-ham sauce. **JAMBON A LA BROCHE**—Ham roasted on a spit. **JAMBON A LA MAILLOT**—Ham braised in wine, served with vegetables and Madeira sauce. **JAMBON WESTPHALIENNE**—Westphalia in Germany is famous for a brand of small hams. **JAMBON GLACE A LA JARDINIÈRE**—A ham baked, glazed, and garnished with various vegetables separately stewed in butter and glazed. **HAM GARNISH**—For filling potato or rice borders, casseroles, croustades, etc., is made by cutting ham in large dice, button onions same size as the ham pieces fried with them; butter and flour and broth made into sauce, and green peas added. **CROUTONS OF HAM**—Chopped ham, chives, parsley, butter, cayenne, yolk; stirred up over the fire; served on fried bread. **MINCED HAM ON TOAST**—Like the preceding; the seasonings of the ham may be varied with catsups, mustard, and bottle sauces. **HAM CROQUETTES**—Made of 1 cup ham, 2 cups dry mashed potato, 1 cup bread-crumbs, 1 tablespoon butter, 1 egg, pepper; made in balls, breaded, fried. **HAM FRITTERS**—Minced ham, bread-crumbs, and egg to moisten; made in pats or balls, dipped in batter and fried. **HAM CAKE**—Remains of ham pounded in a mortar with butter, shaped in a mould, turned out and eaten cold; or mixed with crumbs and egg it makes small ham-cakes to fry and serve hot. **HAM A LA ROYAL**—A fancy ornamental dish for ball suppers, etc. Thin fine slices of lean cooked ham are rolled into cylinder-shapes, fastened with melted gelatine, set on end when cold, and filled with whipped cream containing gelatine to set it and celery-salt for flavor; garnished with green leaves and jelly.

**HAMBURG BEEF**—Beef cured in a salt pickle with spices and herbs; spiced beef.

**HAMBURG STEAK**—Beef sausage meat containing minced onion and a slight flavor of garlic, formed in flat round pats and fried in butter; served either as plain steak for breakfast, or with various sauces as a dinner entrée.

**HANCHE DE MOUTON (Fr.)**—Haunch of mutton.

**HAND GRENADES**—For extinguishing fires. They are thin bottles filled with a chemical liquid said to consist of 4 oz. carb. soda, 2 oz. alum, 2 oz. borax, 1 oz. pearl ash, 1 lb. solution of silicate of soda, 1 gal. water; corked in easily broken bottles which are thrown into the flames if fire breaks out.

**HANOVER BUNS**—Small round rolls or rusks, made of 1 lb. flour, 1 oz. yeast,  $\frac{1}{4}$  pt. warm milk, 6 oz. butter, 2 oz. sugar, 4 yolks, rind of  $\frac{1}{2}$  lemon; fermented and worked like bread.

## HAR

**HARE**—Hares are not found in the United States, unless it be in California, but a great many come to our markets both from England and Canada, and their peculiar gamy flavor renders them generally great favorites. They are very fine eating when young, and very bad indeed when old. Examine the ears; if they tear easily, the hare is young and delicate, and if the body is still stiff, it is in good condition; but never buy a limp hare. The ears of a hare are considered a great delicacy; they require scalding and careful cleaning, and must be closely watched for fear they will burn. **AMERICAN HARE**—Is known as jack-rabbit. It abounds in Colorado and throughout the plains country; is remarkable when dressed for the excess of blood yielded by the meat, and would well fill the requirements for Scotch hare soup on that account. **HARE SOUP**—The chief ingredient of Scotch hare soup is the blood of the animal, which must be properly utilized; therefore let every drop of it be carefully preserved by the cook. A snared hare or a coursed hare is better for soup than one from which the blood has escaped. The hare is cut in joints, steeped in a little cold water to draw the blood; the best pieces of meat saved to boil in the soup, the bones and rough pieces boiled in beef stock with celery, carrot and turnip for 3 hours. Strained, the blood added, and all stirred over the fire till it boils again, then let boil 2 hours more with the pieces of hare in it, and seasonings. Grated potato added for thickening. **PUREE OF HARE A L'ANGLAISE**—The hare is cut up and the blood saved; the pieces fried with liver, onion, carrot and butter; mushrooms, spices, herbs added, and stock, all stewed tender; pieces of hare meat pounded through a sieve, mixed with starch and the blood, stirred in the strained stock over the fire till it thickens. Served with forcemeat balls or quenelles. **LIEVRE EN DAUBE**—Jugged hare; the hare boned, the bones and head pounded and stewed in broth and wine, with vegetables; the hare placed in a jar lined with slices of bacon, seasoned, the bone liquor poured in, bacon on top, baked in a slow oven 4 hours; served in the jar. **CIVET DE LIEVRE**—Another name for jugged hare; stewed hare. **LIEVRE SAUTE**—A hare cut in pieces, fried in butter, served in sauce made of the butter with flour, wine and mushrooms. **FILETS DE LIEVRE**—The fleshy strips from the back fried and dressed in a circle with brown sauce. **FILETS DE LIEVRE PIQUES, SAUCE TOMATO**—Fillets of hare larded and braised, served with tomato sauce. **FILETS DE LIEVRE PIQUES A LA BOURGUIGNOTTE**—Fillets cut in halves, larded and braised; dressed in a crown with brown sauce, bacon cut in dice, young onions, button mushrooms and wine. **COTELETTES DE LIEVRE A LA DAUPHINE**—Hare cutlets; slices off the fillets, with a small bone stuck in each to imitate a lamb chop; breaded and fried. Piquante sauce and chopped olives. **TURBAN DE LIEVRE A LA PERONNE**—Hare cutlets arranged in a circle alternately with quenelles of forcemeat of hare (like epi-

## HAR

gramme of fowl); white sauce with vinegar, pickled onions, etc. **BOUDINS DE LIEVRE**—Rolls of force-meat of hare bread-crumbed and browned—a variation of rissoles or croquettes of hare. **ROAST HARE**—“Opinions are divided as to the propriety of roasting a hare; and we must say that a *civet de lievre a la Francaise*, or even the English jugged hare, are better forms of eating a hare, if it be not true that hares were solely invented to be made into soup, as we have heard Scotchmen say. If, however, you *will* roast your hare, you should lard him very thickly all over the back and thighs. He should be basted plentifully and continuously with butter, and he should not be overdone.” **LIEVRE EN GITE**—Potted hare; jugged hare. “In France we have tureen-gites, made for the purpose; they are very appropriate, the cover representing a hare lying at rest.” Boned hare in a suitable tureen or jar packed with bacon-slices, sausage meat, aromatics, wine, and strong broth made from the bones; baked 3 hrs.; served cold in the jar or tureen.

**HARICOTS (Fr.)**—Beans. **HARICOTS BLANCS**—Navy beans. **HARICOTS VERTS**—String beans. **HARICOTS FLAGEOLETS**—See *Flageolets*.

**HARICOT**—A mutton stew with vegetables; brown. (*See Navarin.*)

**HASH**—Various contrivances with cooked meat; generally small pieces in a brown gravy. **CORNED-BEEF HASH**—(1) Corned beef chopped small and mixed with mashed potatoes, smoothed over in a pan, buttered, and baked brown. (2) Minced corned beef and minced potatoes with an onion, salt and pepper simmered in a little broth and stirred around till partly thickened; served out of the saucepan, sprinkled with parsley. **FRENCH HASH**—Minced onion, butter and flour fried together, water to make sauce of it, small pieces of beef thrown in; when hot, two yolks stirred in, and glass of wine, and seasoning. **HACHIS A LA TOULOUSAINNE**—Hash balls or croquettes of beef made by mincing cooked beef and adding boiled calf's brains and yolks enough to make a paste of it; seasoned with anchovy essence, salt, pepper, spices; balled up, breaded, fried; tomato sauce.

**HATELET (Fr.)**—Skewer; same as *atelet* and *brochette*; generally, however, used to designate the silver skewers used for the decoration of cooked meats.

**HAWK**—A Texas sportsman has pronounced hawk to be excellent food. He found the smell “exceedingly comforting,” and, though rather rich, hawk was “tender, of a gamey, very good flavor, peculiar to itself, and entirely different to that of any other bird I ever ate,” he writes.

**HEAVENLY HASH**—“The curious name for the newest American fashionable dish: Oranges, bananas, lemons, apples, raisins, and pineapples are cut up into little bits, worked just enough to thicken their juices, and then served with a grated nutmeg. But the serving is the pretty part. Cut a hole large

## HER

enough to admit a spoon in the stem end of an orange, which you empty, then fill with the hash, and serve on a little glass fruit-dish with lemon or orange leaves.

**HEAD CHEESE**—Cold dish made of pig's head boiled with seasonings; cut in pieces, stewed down again with the strained liquor, and either allowed to set in the liquor, which is a firm jelly when cold, or pressed into a solid cake. *Collared brawn*, *collared rind* and *fromage de cochon* are other names of the same dish, the ingredients being slightly varied with other odds and ends of meat.

**HEDGEHOG**—A correspondent says that he can from experience safely recommend a hedgehog stewed in milk as a real delicacy. It is well known that roast hedgehog is a favorite dish with English gypsies. “Hedgehog is good, at least for a change, and it used to be well cooked in a small tavern in the Ghetto of Rome, to which artists frequently resorted when their spirits were high and their funds low. According to an aged South Italian sportsman, they should be killed in the woods and immediately skinned, then allowed to hang for a few hours, and, after being trussed with their own quills, be roasted before a sharp fire. The stuffing should be made of their own fat, finely chopped with bread-crumbs and such seasoning as suits the cook's taste.”

**HELENA PUDDING**—A rich bread-custard pudding baked with jam in the bottom of the dish.

**HELL-BENDER**—The hell-bender was first on the list of piscatorial delicacies at a fish dinner. It was pronounced equal to the finest salmon, but only the President and the favored few had a chance to eat of it. It is a higher form of lizard, is about a foot long, is as flat as a pancake, and of a dirty mud color, while a funny little fringe that stands out horizontally runs all the way lengthwise around its body. The head is heart-shaped, and it has wicked little black eyes like beads. Its four stumpy legs end in white toes. It is called by scientific gentlemen the *Menapoma Allegheniensis*, and is a salamander. When you plague it with a stick ever so gently, it humps its back like a Mexican mustang, standing perfectly still on the tips of its white toes. It is said that a hell-bender will seize a stick in a person's hand, and will hang on while it is carried a mile.

**HERRING**—There is a fresh water herring abundant in Lake Superior; its fins however show it to be allied to the salmon family; it is white fleshed and the fillets are boneless, like brook trout. **THE SEA HERRING** is one of the most abundant fishes, but its season is so short that fresh herring is a luxury while it lasts. **FRESH HERRING WITH MUSTARD SAUCE**—Soft roed herrings, the sides scored with a knife, soaked a while in oil, salt and pepper, broiled, served with white sauce with mustard stirred in. **FRESH HERRING WITH ONIONS**—In the Isle of Man and other great herring localities we have seen fried onions served as an accompaniment to

## HIP

fried herring and skad, and it is so generally appreciated that we think those who have not thought of the combination might try it without fear of a disappointment. After the fish are fried, they should be laid on a soft cloth before the fire, and turned every two or three minutes, *till dry on both sides*. It is well to keep old linen table-cloths to cut up for this purpose. **RED HERRINGS AND BLOATERS**—The *herring house* is a lofty shed, about thirty or forty feet high, divided into compartments by racks or horizontal bars of wood, across which the wooden spits, loaded with herrings, are laid as close as possible, from the top of the house to within six feet of the floor. A fire of oak-wood, or billets, as they are called, is then kindled beneath them, and is allowed to burn some six or seven hours. This is called a *blow*, from the effect it has in distending the skin of the fish. In order perfectly to cure the herrings, they must be subjected to ten or twelve such blows, or firings, an interval elapsing between each, to allow the fat and oil to drip from them, so that the process of making a red-herring occupies six or seven days. The *bloaters*, or blown herrings, are subjected to only one firing, and are much less dry. These are intended for immediate consumption, and, of course, do not require so long a time for curing. **RED HERRING ON HORSEBACK**—In former days in England, it was the unbroken custom to serve, at certain seasons, a particular dish first; as a boar's head at Christmas, a goose at Michaelmas, a gammon of bacon, or a "red herring riding away on horseback" at Easter. This last was after the likeness of a man on horseback set in a corn salad. **BAKED HERRINGS**—Fresh herrings twisted in a round, placed in a deep pie dish with vinegar, pepper and a bay leaf; baked 45 minutes, served with the liquor. **HERRING PANCAKES**—Smoked herrings picked from the bone, cut small, mixed in pancake batter, cooled as batter-cakes. **HARENG GRILLES, SAUCE MOUTARDE**—Broiled herrings with mustard sauce. **HARENGS A LA CREME**—Fresh herrings boiled, and served with cream sauce with butter and lemon juice. **HARENGS FUMES A LA BRUXELLOISE**—Boneless sides of smoked herrings broiled in a paper case with a layer of stuffing between them. **CROQUETTES DE HARENGS**—Smoked herrings broiled, made into balls with potatoes same as codfish balls.

**HIPPOPOTAMUS**—Hippopotamus fat is considered a treat; when cured it is thought superior to our best breakfast bacon; and the flesh is both palatable and nutritious, the fat being used for all the ordinary uses of butter.

**HISTORIE EE** (Fr.)—Decorated with small figures.

**HODGE-PODGE SOUP**—Common English for Hotch-Potch, a mixture; mutton soup thick with pieces of meat and all sorts of vegetables. (*See Hot-Pot.*)

**HOKEY-POKEY ICE CREAM**—Italian *Occhi-*

## HION

*Pocchi*—mixed colors and flavors of ice cream in cakes; one form of *biscuits glaces* or ice cakes.

**HOLLANDAISE SAUCE**—A yellow sauce served with boiled fish, cauliflower and asparagus, made by boiling 3 table-spoons vinegar with salt and white pepper till half reduced; cooled with a spoonful of cold water, 4 yolks beaten in, then  $\frac{1}{2}$  lb. butter in bits, stirred over the fire till the yolks thicken it but not boil.

**HOMARD**—(Fr.)—Lobster. **POTAGE DE HOMARD**—Lobster soup. **COTELETTES DE HOMARD**—Lobster cutlets, or croquettes in cutlet shapes.

**HOMINY**—Is grains of Indian corn freed from the outer covering of bran, and therefore is white. There are three or four different grades as to size, from the coarse hominy, as large as peas down to the white meal known as hominy grits or samp. It is very cheap food; usually only 2 or 3 cents per pound by the barrel. The large hominy is used as a vegetable, like rice; and after boiling quite tender it is fried and served for breakfast. **FRIED HOMINY**—The form of fried hominy that is served with canvas-back ducks *a la Maryland*, is fine hominy well boiled, sliced in shapes when cold, rolled in flour or corn meal and fried. **HOMINY GRITS**—Hot porridge for breakfast or supper, made of fine hominy soaked in water several hours; boiled or cooked in a double kettle for 2 or 3 hours, served with milk or cream. **HOMINY PUDDING**—Made the same way as rice puddings. **HOMINY FRITTERS**—(1) Coarse hominy well cooked, stirred into enough flour batter to hold it together, spoonfuls dropped into hot lard and fried brown. (2) Fine hominy porridge, with eggs, sugar, and little flour beaten in; spoonfuls dropped in hot lard and fried brown. **HOMINY CROQUETTES**—Fine hominy porridge mixed with grated cheese, eggs and little flour, rolled up when cold and stiff, egged, breaded, fried. **HOMINY AND CHEESE**—Cooked hominy of either kind made up with cheese, baked brown. **LYE HOMINY OR HULLED CORN**—Indian corn steeped in water containing lye or potash till it swells and the skin is partly dissolved, washed and either boiled with milk, or fried.

**HONEY**—Buyers and consumers of honey will do well to note that the suspiciously light and bright product, variously labelled "Californian Honey Dew," "Swiss Table Honey," etc., etc., is frequently a sophisticated article made up of glucose and such-like substances brightened by mineral acid. Furthermore, darkness is no indication of inferior quality, as some suppose. The color of honey depends upon the sources from which it is collected by the bees, and much of that which is of a dark color is quite equal (and in some cases superior) to that which is light in color; honey collected by the bees from white clover, limes, fruit blossoms, sainfoin, hawthorn, turnip, bean, heather, etc., being of different hues. **HONEY IN THE COMB**—Is offered for sale almost everywhere in the season, and is the best



## HOP

to serve in place of fruit for supper and of syrup for breakfast. **HONEY MEAD**—A kind of wine. (*See Mead.*) **HONEY CAKE**—Made of 1 qt. strained honey, 1 lb. sugar,  $\frac{3}{4}$  lb. warm butter, a tablespoon soda, 2 tablespoons caraway seeds, flour enough to make into dough. Made up and baked like sheet gingerbread.

**HOPS**—Needed by the baker to make yeast with. They will not make yeast alone but mixed with mashed potatoes and scalded flour or any kind of meal they strengthen the fermentation and prevent sourness. Can be purchased in packages pressed. About 4 oz. to each pailful is required. **HOP BEER**—Hops boiled in water and molasses or sugar added to the water after straining, some yeast stirred in when cool, ferments and makes beer in a few days.

**HORLY OR ORLY**—It is spelled both ways by equally good authorities, is supposed to be the name of a French admiral. Only one dish seems to carry that designation, consequently *a la Horly* always signifies the same thing, viz, strips of fish dipped in batter and fried and served with onions cut in rings fried dry.

**HORSE MEAT**—"To revert to horse-flesh and the eating of it in Paris, M. Morillon has given me the following statistics: Thus of this flesh was consumed in 1883 something like 5,000,000 lbs. and about 6,000,000 lbs. 1884. Besides, there is to be added about 2,000,000 lbs. imported into Paris, so that the total consumption of horse, mule, and donkey flesh in this city during the last year was about 8,000,000 lbs. (eight million pounds! or four pounds per head of the entire population.) Now, what part of these eight million pounds did I eat? Who shall say? Ah! who shall say?"

**HORSERADISH**—The root of a coarse-looking large-leaved plant which once rooted in a garden corner grows and spreads year after year without much attention. The plentiful time for it is in spring, when the roots are taken up and divided for replanting; the great surplus of roots can then be grated and bottled in vinegar for use during several succeeding months. **GRATED HORSERADISH**—There are small machines, being revolving graters, for reducing the roots to the desired fineness. Of all the sauces which can be made none are in so much demand and so generally acceptable as plain grated horseradish in vinegar, which should be set upon the table in ornamental jars or other proper receptacle. **ADULTERATIONS**—Much of the grated horseradish purchased in bottles is weakened in strength by mixture with grated turnips, cabbage stalks, kohlrabi, etc., and enterprising and unscrupulous gardeners make immense profits during short seasons by putting up these fair-looking but too mild flavored imitations. Pure horseradish is too strong to be eaten extravagantly, while the adulterated article is but a mild and palatable relish and becomes too costly for use at horseradish prices on account of the large quantity which will be consumed. It is

## HOT

wise, therefore, to buy the root and have it grated on the premises. **HORSERADISH SAUCE**—Grated horseradish boiled in broth, one or two yolks beaten up with some tarragon vinegar stirred into the horseradish to thicken, but not allowed to boil; pepper and nutmeg added. **GERMAN HORSERADISH SAUCE**—Grated horseradish boiled in gravy or plain water; yolks beaten up with cream and vinegar stirred in to thicken; not allowed to boil. "This sauce is invariably served in Germany with all forms of beef, either broiled, roasted, or boiled." **NAPOLITAINE SAUCE**—Horseradish in brown sauce with port wine, ham, Worcestershire and currant jelly. **RAIFORT SAUCE**—Horseradish sauce; made of 2 to 3 oz. grated horseradish in  $\frac{1}{2}$  pt. cream sauce and a wine-glass of white-wine vinegar. **HORSERADISH MUSTARD**—Horseradish boiled in water, strained out, and the water used to mix mustard; good condiment for beef. **HORSERADISH BUTTER**—Grated horseradish, butter and lemon juice kneaded together; the butter then rubbed through a seive; served with beefsteaks.

**HOT BREWS**—Various hot drinks. **CARDINAL**—Hot spiced port and burgundy mixed with water according to taste. **BISHOP**—Hot spiced burgundy with roasted crab-apples floating in it—"obviously an antique custom, since Shakespeare makes Puck refer to 'the roasted crab in the bowl,' which the mischievous sprite delighted to make bob against the old gossips' lips." **MULLED WINES**—"For making mulled wines generally, it is said that you should take of spices five—cloves, cinnamon, allspice, nutmeg, and mace—boiling them in a pint of wine until the concoction is quite aromatic and bitter. It should then be bottled off and kept in store, a tablespoonful of the essence to be used for flavoring whatever wine is mulled. For sweetening, loaf-sugar is indispensable, unless prepared syrup be preferred." **WHITE WINE WHEY**—For colds; made by pouring a wine-glass of cowslip-wine into  $\frac{1}{2}$  pt. boiling milk; it immediately curdles, is strained, and the clear liquor sweetened is drunk hot. **LAIT DE POULE**—Made of 1 egg beaten up with sugar,  $\frac{1}{2}$  pt. hot milk poured to it, and a spoonful of brandy. **HOT APPLE TEA**—For colds; sliced apples with sugar, boiling water poured to them, steeped; the liquor drunk hot. **YARD OF FLANNEL**—Spiced ale heated nearly to boiling point (the spice being ginger and nutmeg), an egg or two beaten up in it, and sugar; poured from one large glass to another several times, drank foaming and hot. **WASSAIL BOWL**—Name applied to hot beer and wine, with spices and spirits added, in the olden time. **LOVING CUP**—Any hot brew or punch was a loving cup when the glasses of the drinkers were clinked together and toasts and sentiments were pledged. **APPLE TODDY**—A roasted apple in a glass, 1 teaspoon sugar, whisky enough to cover the apple, hot water to fill up. **PUNCH**—Whisky, brandy or rum with lemon, sugar and hot water. **COUNCILLOR'S CAP**—Made of  $\frac{1}{4}$  lb. loaf sugar rubbed on the rind of 2 oranges;  $\frac{1}{2}$  pt. orange juice, juice of 1 lemon,  $\frac{1}{2}$  pt. brandy, 1 pt.

## HOT

boiling water. **CREOLES SKIN**—Quarter glass boiling water, 1 glass black currant wine, a dash of gin. **MERRY MEN**—Half glass boiling water, 1 glass Irish whisky and a dash of bay rum. **RED PEPPER SKIN**—Half glass boiling water, 1 teaspoonful essence of capsicum or pepper sauce. **GINGER SKIN**—Half glass boiling water poured on 1 teaspoon grated ginger; 15 drops essence of capsicum.

**HOT-POT**—"A thousand hot-pots (made of 4,000 lbs. of meat and 10,000 lbs. of potatoes) were distributed from the bakeries of Liverpool amongst the poor of that city at Christmastide. Each hot-pot was supposed to yield ten substantial dinners." **LANCASHIRE HOT-POT**—"Take an earthenware pan with cover, holding a quart or more. Take 1 lb. of potatoes, boil them three-parts, and when cold cut into slices. Take three sheep's kidneys and bruise them to pieces in a mortar. Take 2 lbs. of cutlets from a neck of mutton, and pare them neatly of fat and skin; take 18 oysters and preserve their liquor; take a few mushrooms, clear them of all white, and mince; take salt, pepper, and curry-powder in moderate proportions. Now form in your pan alternate layers of cutlets, kidneys, potatoes, oysters, mushrooms, salt, pepper, and curry-powder; add the oyster liquor; keep all gently simmering in a moderate oven for 3 or 4 hours. Half an hour before serving make a rich brown gravy with a gamey flavor, and add it to the above. Serve in the pan."

**HOTCH-POTCH**—French hot-pot; baked soup; made of 2 lbs. beef, 1 lb. sausage meat, 1 onion, 1 cucumber, 3 tomatoes, few asparagus tops, 1 carrot, piece of cabbage, ½ cup raw rice, 2 cups green peas, pepper, salt, cold water. "Cut the meat small and put in alternate layers with the vegetables and rice into a stout stone jar; pour in 3 qts. of water when you have seasoned the vegetables; fit a close cover on the jar, sealing around the edges with a paste of flour and water; set in the oven early in the day, and do not open for 6 hours; then pour into the tureen, and serve."

**HOT SLAW**—Cabbage finely shaved off the head, put in saucepan with water, vinegar, butter, red pepper, salt, little sugar, yolks of eggs; brought slowly to the boiling point; liquor is like thin custard; must not boil. **COLD SLAW A LA BOHEMIENNE**—Same as the preceding without eggs; boiled in the vinegar-water for 20 minutes.

**HUCKLEBERRY**—See *Wortleberry*.

**HUITRES (Fr.)**—Oysters.

**HURE DE SANGLIER (Fr.)**—Boar's head.

**HURE DE SAUMON (Fr.)**—Head and shoulders of salmon.

## I.

**ICE**—In New York the daily consumption of ice in the summer months amounts to upwards of 10,000 tons. At the proper hour you may walk down a street and see upon every door-step a lump of ice

## ICE

varying in size from a foot square upwards. In fact, ice is as much an article of necessity with Americans as milk. **HOME-MADE ICE**—To make ice at home, says *La Science en Famille*, take a cylindrical earthen vessel and pour three and one-third ounces of commercial sulphuric acid and one and three-fourths ounces of water into it, and then add 1 ounce of powdered sulphate of soda. In the centre of this mixture place a smaller vessel containing the water to be frozen; then cover the vessel and, if possible, revolve the whole with a gentle motion. In a few minutes the water in the small vessel will be converted into ice. The same mixture can be used a second or third time for making a block of ice. The operation should, if possible, be performed in a cool place—in a cellar, for example. **ICE ORNAMENTALLY USED**—At a princely entertainment there were 19 tables arranged about a lofty central crystal fountain 9 feet high and 5½ feet in diameter, from which the water trickled down through trailing plants, amidst which stood aquatic birds of gay plumage. The fountain was surrounded by a gravel path with rock-work. Huge blocks of ice were raised on buffets 7 feet high in various parts of the room; into these were thrown different shades of color, thus giving a striking effect. **ICE WINDOW ORNAMENT**—A dome of ice hollow and with a light inside makes an attractive window show for a restaurant or ice-cream house. It is made by setting a round-bottomed copper candy kettle full of water, plain or colored, in a tub of ice and salt freezing mixture. When frozen an inch or two thick, turned out, a hole bored in the bottom with a hot iron, used bottom side up, with a lamp or gas inside. **ICE STANDS FOR ICES**—Colored water frozen solid in moulds, turned out on a napkin, to serve as stands for moulded ice-creams, frozen puddings, etc. Different colors. **ICE BLOCKS FOR STRAWBERRIES**—There is no more tempting way of serving strawberries, on a hot morning, than from a block of clear ice. Chip a well in its centre and drop the berries into it. A cluster of yellow roses, or other flowers, or even ferns alone, will prove appropriate decoration.

**ICES**—Frozen sweets of all kinds, particularly water ices and cream ices, or sherbets and ice creams. **SORBET A L'IMPERIALE**—A new form of ice, to be served in ice-cups between the courses; flavored with pineapple or strawberry, rum being used with the former and champagne with the latter; but so deftly concocted, that the most suspicious teetotaler would partake of it in blissful ignorance. **NOVEL FORMS**—Ice-cream is now served in the form of a water melon; oysters on the shell at dinner parties come enveloped in shredded lettuce like sea-weed; sherbet is served in tiny pasteboard punch bowls, and cherries and plums filled with cordial are served with dessert. **MOULDED CELEBRITIES**—"When in Munich, the daughters of Wagner, the composer, ordered ices at a café, and these were placed before them made into the likeness of

## ICE

Wagner. Of course, they were surprised, and refused the ices, and explanations became necessary. 'Oh, we cannot eat our father's head!'" **MARQUISES JAMAÏQUE**—The Marquises Jamaïque, which came as a very pleasant relief from the eternal punch Romaine, were ices flavored with Jamaica rum, an excellent stimulus in mid-dinner. **ICE CREAM AS WAFFLES**—"Turkey wings and mushrooms was a course at a club dinner party last week, and the ice-cream came on the table in the form of waffles." **ICED RICE SNOWBALLS**—"A new entremet, deliciously cool and tempting at this time of year, is iced rice snowballs. Freeze in the shape of balls, rice well boiled in water, and flavored with lemon or orange, and serve in a green glass dish, covering each balls separately with whipped cream. **PARFAIT LEGER AUX CERISES**—A new and delicious iced sweet, invented by the *chef* for the occasion of a dinner to the Prince and Princess of Wales: Cherry juice, to which a slight *souçon* of Kirschwasser is added, is frozen lightly and mixed with sweetened whipped cream, the color being heightened by a little cochineal. The mixture is placed in suitable moulds and lightly frozen. A sauce, composed of cherry juice and unfrozen whipped cream, is served with the above in a sauce-boat. **A ROSE OF ICE**—One new idea is a large rose of ice, with bud and leaf of the real flower inserted. Sometimes the ices take the form of a lighted candle, the socket being made of brown ice, the candle of pistachio, and the flame of cinamon. **MOUSSES GLACES, OR ICED FROTHS**—Whipped cream sweetened and variously flavored piled in glasses and frozen in the same glasses in which they are served. **CHESTNUT MOUSSE**—Purée of chestnuts mixed with whipped cream, sugar and vanilla, frozen in a mould. **ICED QUAILS, OR CAILLES A LA LESSEPS**—The little birds boned, stuffed, and masked with rich brown gravy, resting against a block of ice, and all surrounded with transparent aspic. A fruit salad, in cups of solid ice, served as a fitting introduction to this dish. **NEAPOLITAN SORBETTO**—"Some of you make the best ices in the world, of which I have had practical experience. But why is it that it is impossible to get the Neapolitan *sorbetto*, which is something between a water ice and a glassful of flavored snow in a state of thaw? *Gramolata*, I should call it, rather, or *granita*, as in Florence. I presume it is as easy to make as a water ice, and only needs less freezing. In the summer it is the invariable first breakfast of the Neapolitan, who would be thrown into a fever by any hot beverage. The favorite flavors are lemon, coffee, and cedar, and it is usually eaten with biscuits or crescents." **ROMAN GRANITO**—Equal parts of strong coffee and plain sugar syrup, put into wide-mouthed bottles, placed in a freezing mixture of ice and salt till half frozen, served in coffee cups or glasses. **CLARET GRANITO**—Juice of 6 oranges, rind of 2, 1 pt. syrup, 1 pt. claret; the orange rind previously steeped in the syrup. Half frozen like *roman granito*. **PUNCH**

## ICE

**GRANITO**—Made of 3 wineglassfuls each of tea, brandy, rum, syrup, maraschino, pineapple syrup, orange and lemon juice and a pint of champagne. Same way as other granitos. **GLACE A L'ORANGE**—Made of 1 qt. syrup, 1 pt. orange juice, rind of 3 oranges infused in 1 pt. water, strained, frozen. **ORANGES FILLED WITH ICES**—Circular piece cut out, orange skin emptied with spoon, filled with orange ice in which are glacé fruits soaked in maraschino. Piece replaced, oranges frozen in sorbetiere before serving. **REINE-CLAUDE ICE**—Green-colored ice-cream, made of pulp of green-gage plums mixed with whipped cream after being nearly frozen. (*See Gateau Stanley.*) **FROZEN SOUFFLES**—Equal parts of rather firm and sweet custard, strongly flavored with vanilla, white of egg beaten stiff, and whipped cream. Mix these three ingredients very lightly together, and fill into moderate-sized paper soufflé-cups, which place in an ice-cave. **PISTACHIO CUSTARD ICE**—Custard made of cream, sugar and yolks, pistachio nuts blanched and pounded, green coloring, orange flower water, vanilla; frozen as ice cream. **ORGEAT ICE**—Orgeat is milk of almonds, made by pounding ½ lb. almonds, adding 3 qts. water, sugar, orange flower water, strained, frozen. **GLACE CREME DE THE**—Tea ice-cream. **GLACE CREME DE VANILLE**—Vanilla ice-cream. **GLACE CREME DE RATAFIAS**—Almond macaroon ice-cream. **GLACE CREME BAVAROISE**—Frozen Bavarian cream. **GLACE CREME DE FLORIDA**—Ice-cream with infusion of orange flowers. **GLACE CREME DE CAFE**—Coffee ice-cream. **GLACE CREME DE NOYAU**—Noyau ice-cream. **CREME D'ABRICOTS**—Apricot ice-cream. **CREME DE PECHES**—Peach ice-cream. **CREME DE FRAISES**—Strawberry ice-cream. **CREME DE FRAMBOISES**—Raspberry ice-cream. **CREME DE GROSEILLES**—Currant ice-cream. **CREME DE CERISES**—Cherry ice-cream. **CREME DE RAISINS**—Grape ice-cream. **CREME D'ANANAS**—Pineapple ice-cream. **CREME DE CITRON**—Lemon ice-cream. **CREME D'ORANGES**—Orange ice-cream. **CREME D'AMANDES**—Almond ice-cream. **CREME DE PISTACHES**—Pistachio nut ice-cream. **CREME DE MARRONS**—Chestnut ice-cream. **CREME DE GINGEMBRE**—Ginger ice-cream. **GLACE EAU DE CANNEBERGES**—Cranberry water-ice. **GLACE EAU DE RHUBARBE**—Rhubarb water-ice. **GLACE EAU DE PONCHE**—Punch water-ice. **EAU DE MELON**—Melon water-ice. **EAU DE GRENADE**—Pomegranate water-ice. **EAU DE MILLE FRUITS**—Mixed fruit water-ice. **BISCUIT GLACE**—Made of thick sugar-syrup flavored with vanilla, beaten into 8 yolks for each pint, stirred over a slow fire till it thickens, stirred again on ice till cold and frothy; mixed with equal quantity of cream whipped to froth; filled into paper cases powdered with macaroon dust; frozen in the cases. **PARFAIT AU CAFE**—Coffee ice-cream frozen in a mould, made of coffee-syrup; beaten into 8 yolks for each pint, thickened over the fire; stirred then on ice, mixed with whipped cream. **CHARLOTTE PLOMBIERES**—

## ICE

Another name for tutti-frutti ice cream, or *crema de vino*; made of vanilla ice-cream mixed with whipped cream, *kirschwasser* to flavor, and candied fruits; frozen as a charlotte in a mould lined with lady-fingers. **GLACE DE PLOMBIERES**—Almond custard mixed with whipped cream and frozen; not moulded, but served with apricot jam. **GATEAU GLACE A L'ELOISE**—A mould lined with whipped cream frozen, interior filled with stewed cherries in custard, all frozen solid; turned out; served with a custard over it. **BAKED ICE CREAM or GLACE MERINGUEE AU FOUR**—Ice cream turned out of a mould, covered with very cold meringue and quickly browned a little in a hot oven or with red-hot iron. **ICE BAKED IN PASTE or GLACES AU FOUR**—Small pieces of ice folded in paste carefully to exclude the air; baked brown quickly in a hot oven. **BOMBE A LA SOUVERAINE**—Mould lined with white paper, inside coated with almond ice-cream, filled up with tea custard mixed with whipped cream; frozen solid in mould. **MOUSSE AU CAFE VIERGE**—Coffee custard mixed when cold with whipped cream; frozen solid in a mould. **CHARLOTTE GLACE A LA MEDICIS**—Charlotte-russe filled with chocolate ice-cream. **GLACE PRALINEE A L'ORANGE**—Mould filled on one side with almond nougat ice-cream, the other side with orange water-ice. **FILBERT ICE-CREAM**—Nougat or filbert candy pounded, used to flavor the cream. **FLORENTINE ICE-CREAM**—Custard and cream flavored strongly with orange-rind; frozen. **MOUSSE AUX FRAISES**—Strawberry pulp, sugar and whipped cream frozen. **MUSCOVITE WITH CURRANTS**—Russian or whipped jelly made of currant juice and gelatine, mixed with whipped cream frozen in a mould. **MOUSSE AU CAFE NOIR**—Coffee custard when cold mixed with whipped cream and frozen. **MOUSSE AUX PECHES**—Pulp of ripe raw peaches with custard and whipped cream; frozen. **MUSCOVITE OF PEACHES**—Peach pulp, sugar, gelatine and water mixed with whipped cream, and frozen. **MOUSSE AU MARASQUIN**—Custard of yolks and syrup flavored with maraschino and *kirschwasser*, mixed with whipped cream, and frozen. **MUSCOVITE OF PINEAPPLE**—Grated pineapple, sugar and gelatine made into jelly, whipped, mixed with whipped cream, and frozen. **BOMBE AUX FRUITS**—Bomb-shaped mould lined with chocolate ice-cream, center filled with tutti-frutti; frozen solid. **EXCELLENT AU CAFE**—Coffee-flavored custard mixed with whipped cream, and frozen in a square mould. **SPONGADE DI ROMA**—Frozen egg-nogg. **BROWN BREAD ICE-CREAM**—Slice of brown bread without crust, and slice of sponge cake dried in the oven, pounded, sifted, mixed in curaçao; frozen. **PUNCH ICE-CREAM**—Made of 1 pt. cream, 2 glasses Jamaica rum, ½ pt. green tea, juice of ½ lemon, 8 oz. sugar; frozen. **CREMA DI VINO**—A tutti-frutti with wine made of cream custard; white wine, sugar, cut candied fruits; frozen. **RICE ICE-CREAM**—Rice boiled in milk, mixed with custard and cream; frozen. **COCOANUT ICE-CREAM**—Either

## ICE

white or yellow, made by mixing grated fresh cocoanut, or desiccated cocoanut scalded in either custard and cream or starch-thickened cream. **PANACHEE ICE-CREAM**—Different colored ices in the same mould; marbled ice-cream; ribbon ice-cream; harlequin ice-cream. **GLUCOSE IN ICE CREAM**—See *Glucose*. Glucose used for sweetening instead of sugar makes ice cream smooth and light and foamy; a valuable wrinkle. **GELATINE IN ICE CREAM**—A small quantity of gelatine, not more than 1 oz. in 2 qts., makes it smooth and light and less easy to melt. Wine jelly or any gelatine jelly can be employed as well.

**ICED SOUPS**—Clear soups are sometimes served ice-cold, like iced tea or coffee, in consommé cups. "At a recent ball-supper given by the Rao of Cutch in London, iced soup was served, and eagerly devoured by the guests, who were regaled with true Indian curries and devilled chicken of superlative excellence."

**ICED PUDDINGS**—Compound ice-creams, such as those containing fruit, nuts, cocoanut, rice, tapioca, etc., are sometimes called iced puddings; some

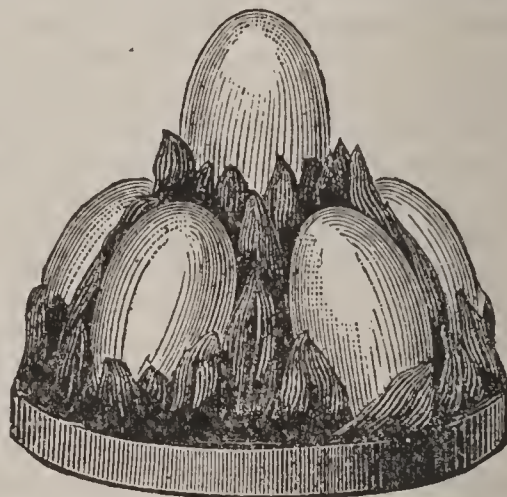

ICE MOULD.

For several colors, or ice puddings, creams, etc.

are composed of two parts in a mould as an outside of rice ice-cream with a filling of apple-ice. The best known is called *Nesselrode*, which see.

**ICELAND MOSS**—A lichen which serves the purpose of making jelly like gelatine.

**ICE-MAKING MACHINES**—Artificial ice is made in almost every large town, even in the far south and the West Indies. Small machines for family use also are on sale. The freezing is effected by the rapid evaporation of ammonia, which produces intense cold in pipes which run through brine, which thus becomes cold enough to freeze fresh water that is set in it in cans. The ammonia is condensed and used over again. A complete hotel "plant" costs from \$2,000 to \$3,000.

**ICE CRUSHERS**—Various devices for crushing, shaving and rasping ice are in the market, suitable for ice-cream freezers and bar-tender's use.

**ICE-CREAM MOULDS**—They are made of all

## ICI

shapes and sizes, of tin, copper, lead and pewter; like melons, pyramids, fruits, bricks, bombs, jugs, and new designs are always coming out. Figures, such as cupids, birds, etc., are in two parts hinged together; the joints are sealed up with butter to keep the salt water from reaching the ice cream inside. It is found best to line such moulds as admit of it with white paper to facilitate the withdrawal of the moulded ice.

**ICING CAKES**—Sometimes called frosting; the covering of cakes with a coating of sugar, and ornamenting them.

**ICING**—Is of several kinds. **WATER ICING**—Fine powdered sugar wetted with water, and flavored, and spread over the surface of the cake. It is of a pearly, semi-transparent appearance, and does not break when the cake is cut. Is also made with fruit-juices or syrup instead of water, or with wine, or colored with any confectionery coloring. **FONDANT ICING**—Creamed sugar, such as chocolate-cream drops, etc., are made of, is partially dissolved and poured and spread over cakes while warm, and

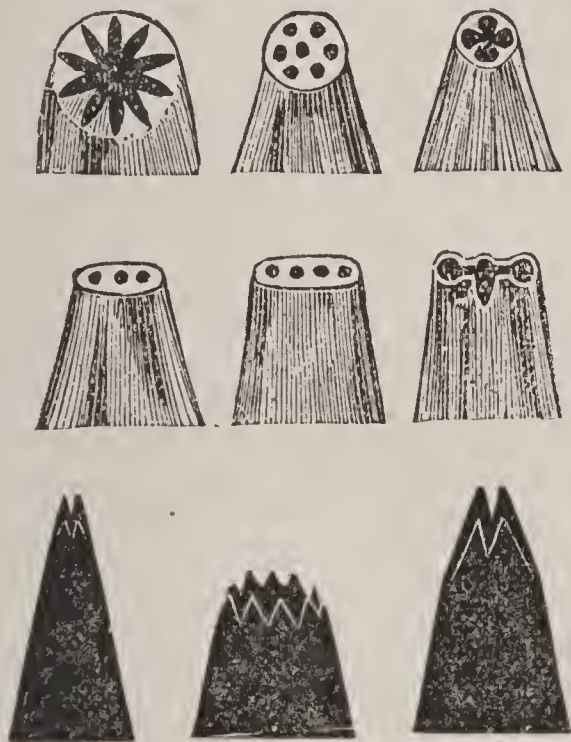

TUBES FOR CAKE ORNAMENTING.

considered the best kind of icing. It contains no white of eggs, but the sugar is boiled to the degree of soft ball, then worked with a paddle on a slab till perfectly white. **WHITE-OF-EGG ICING**—Powdered sugar wetted with white of egg and beaten with a paddle about 15 minutes, or till firm and white. A little acid of any harmless kind assists in the making. When firm enough to pipe ornaments on the cake, part of it is thinned down with more white of egg to spread over the surface of the cake smooth and glossy; the ornamenting is put on when the coating is partly dry. **CHOCOLATE ICING**—Grated chocolate beaten into boiling sugar at the stage of the "feather" or soft ball, a little lard or fat of some kind added to make it glossy. **YELLOW ICING**—Made with yolks and sugar; or, white icing colored. **AL-**

## IND

**COHOL ACID TO STIFFEN ICING**—Bakers' specialty. One ounce citric acid in 2 oz. alcohol; it slowly dissolves; a few drops added to icing when beating makes it firm and white.

**ICING TUBES OR POINTS**—Small cones of thin brass or other metal about an inch long, to be obtained at the confectioners' supply stores. The points are filed into various shapes, which shape the cords of icing pressed through them. They are used by dropping them as point into a cone-shaped bag or paper, with the points cut off to receive them, and the bag is then filled with icing.

**IMPERIAL GENOISE CAKE**—Richest cake mixture; made of 1 lb. sugar, 16 eggs, ½ lb. butter, ¾ lb. flour, ¼ lb. ground almonds, vanilla, almond and lemon extracts. Eggs and sugar whisked in kettle set in warm water, melted butter poured in, then almonds and flour. Baked in shallow moulds or in sheets.

**IMPERIAL PUNCH**—Made of pineapple, oranges, vanilla, lemons, sugar, cinnamon, hock, rum, champagne, seltzer, and water.

**IMPERIAL PUDDING A LA CORDON BLEU**—Dry cooked rice rubbed through a seive, seasoned with little butter, sugar and cinnamon; mould lined with it. Inside filled half with grated pineapple and raw egg, rest of space with cocoanut, custard (raw), with eggs plenty to set firm; steamed, turned out of mould.

**INDIAN PIUTE COOKERY**—"The Indians at the Sink of the Humboldt catch a great many small fish, of which they make a kind of chowder. The fish are caught by means of dip-nets, some 8 feet square, suspended from a pole supported on two crotchets, like an old-fashioned well-sweep. These nets are worked by the squaws. They catch from a quart to a peck of minnows at a dip. The fish so caught are beaten into a sort of pulp or paste, just as they come out of the water, insides, outsides and all. A certain amount of flour is then added to the mass, and it is either baked and eaten as a cake or boiled and eaten as a sort of soup or chowder."

**INDIAN PUDDINGS**—Made of corn meal, generally boiled mush or porridge mixed with butter, syrups, eggs, ginger, baked.

**INDIAN CHUTNEY**—Relish made of 8 oz. sugar, 4 oz. salt, 2 oz. garlic, 2 oz. shallots, 4 oz. ground ginger, 2 oz. red peppers, 4 oz. mustard seed, 6 oz. raisins stoned, 1 bottle vinegar, 15 large sour apples, 6 oz. tomatoes. Chop up the garlic, shallots, tomatoes, and raisins, and wash the mustard seed in vinegar and let it dry. Then add all to the apples and sugar, and boil slowly for an hour and a half. Add the other half-bottle of vinegar; let it cool, and bottle off or cover in jars.

**INDE (Fr.)**—Coq d'Inde is the old name of the turkey, whence the present *dinde*. The old French is still sometimes used in bills of fare.

**INDIENNE (Fr.)**—Relating to the East Indies.

## IRI

SOUP A L'INDIENNE—Curry soup. SAUCE INDIENNE—Indian sauce or tomato sauce with curry and anchovy essence. INDIENNE DE POULARDE—Chicken or capon in Indienne sauce or curry sauce—used in the same sense as a Snedoise (Swede) of peaches, or Muscovite of apricots.

IRISH MOSS—Similar to Iceland moss and used for the same purpose. A determined attempt was made a few years ago to popularise these mosses for use instead of gelatine and isinglass, but the prepared moss was never free from a peculiar and unpleasant taste and the efforts of the manufacturers proved abortive.

IRISH STEW—Mutton stewed with potatoes and onions, salt and pepper, until quite tender, and the liquor is reduced to the richness of gravy. A certain essayist assures us that there are three dishes which, if put upon the bill of fare of a club, are devoured before all else, so that at seven or eight o'clock, when most members dine, there is nothing left of them but the tempting words on the dinner-bill. These dishes are Irish stews, tripe and onions, and liver and bacon! "What a tribute," exclaims our author, "to the homely cookery of Britain."

ISINGLASS—Made from fish, the best is made from the swim-bladder of the sturgeon. It is used for making jelly and for all the purposes of gelatine but being dearer than that is not now much used. When gelatine was first made in a refined and shredded form it was sold as isinglass.

ITALIAN COOKERY—As the spit and gridiron are specialities of the English kitchen, so the frying-pan is the speciality of the Italian cook; and, as England has taught the world to roast, so Italy has taught the world to fry. Frying is quite a science in that country and a science which every maid and mistress studies with all her might, for as there is no Italian dinner without its *ante-pasto*, so there is none of any consequence without its dish of *fry* or *fritto*, as it is called in Italy. Meat, fish, vegetables, all may be fried, and generally meat and vegetables, or fish and vegetables, are fried together. Whatever the articles, they must be fried in boiling fat, and at a brisk fire. Not a moment must elapse between the frying and the serving. The smallest delay is ruinous to the success of the dish, as it tends to make the *fritto* lose its crispness, and become flabby. Whilst the soup is being taken, the *fritto* is cooked. If need be, good eaters will readily consent to a "wait" rather than endanger the full success of the *fritto*. OIL FOR FRYING—Oil is much used in Italy for frying, especially for fish. But Italy has the advantage of pure oils, which this country does not possess. Oil, even the best, has the disadvantage of burning very easily and of making the *fritto* too dark in color, instead of a rich golden-brown, which it should be. FRITTO MISTO—Every kind of meat, vegetables, and fish may be fried. The favorite Italian *fritto*, however, is the mixed *fritto*—composed of veal cutlets, calf's brains (which

## ITA

is quite equal to sweetbread) and sliced artichokes, gourds or potatoes cut in short narrow sticks. A great secret of the excellence of the Italian *fritto* is that everything that is to be fried is previously soaked in a batter made of different ingredients, which vary according to what has to be fried. For an ordinary mixed *fritto*, for instance, you make a batter composed, say, of a quarter of a pound of flour to the yolk of one egg, a tea-spoonful of vinegar or the juice of half a lemon, and thirty grains of fine oil. Beat well together, adding occasionally a little water or beer, or white wine, just enough to make the batter liquid. Then beat the white of the egg apart and to a foam, and add this foam to the batter at the very last moment, just as you are going to fry. The calf's brains must be well cleaned, skinned, and rinsed or boiled for a few minutes before being fried, and the same with sweetbread; they must be then left to cool. When cold they are cut into small pieces, about the size of a large walnut. Soak them first in a little oil, salt, and vinegar. Then dry then with a clean cloth and soak in the batter, from which they are thrown into boiling fat or butter and fried to a rich golden color. When quite crisp, and of the required color, take them out of the fat and lay them on clean white paper or a clean cloth, to absorb the fat. They should also be served on a cloth. Cutlets only require to be soaked in the batter previous to frying. Vegetables, whether artichokes, cauliflowers, or gourds, are partly boiled in salt and water before being fried. Potatoes are better not previously boiled, but they are cut into short thin strips in order to fry easily. Artichokes must be trimmed of all their outer tough leaves, the heart alone being fried; this is cut into four parts like an orange. ROMAN FRY SHOPS—In Rome there are frying shops as close together as public houses in London, and there persons who may not have the necessaries to cook at home—as those who live in a poor lodging-house, for instance—can have a good plateful of *fritto* for a few pence. There is a clean batter before you, and the vegetables and meat prepared for the pan, and the snowy white cloth on which to eat. You choose the pieces you like best, and these are fried before your eyes with a cleanliness equal to the silver gridiron of London restaurants. These fry-shops are celebrated institutions in Rome, and in some high born ladies and gentlemen go to supper on certain days of the year. Saint Joseph is the patron saint of Roman frying men and women. On that day the fry-shops are things to see. They are decorated both within and without with white and colored draperies, and flowers, and foliage, and flags, and banners, and pictures, and ornaments of every kind. Clerical Josephs decorate their houses with images of St. Joseph himself. Liberal Josephs decorate their shops with pictures of Garibaldi, whose name was Joseph. It will be seen, therefore, in what repute the frying-pan is held in Italy. Nearly one hundred different fried dishes enter into the Italian *cuisine*, one-half being of meat, and the other

## ITA

half of vegetables and cereals for fasting days. The way the Italians fry liver, is exquisite. You require for this calf's liver, butter, capers, pine seeds, allspices, sugar, lemon-juice, vinegar, flour, salt, and pepper. Cut, say, 10 oz. of calf's liver into slices, and fry half these in butter. When fried, pound it in a mortar, with a few capers, a few pine seeds, allspice, and sugar; then strain, and add the juice of a lemon, and a little pepper, salt, and vinegar. Put the whole in a hot-water bath, or near the fire, but not on it. Flour the rest of the sliced liver, and fry in fresh butter. When fried, place the slices on a plate, and pour over them the first part reduced to a thick sauce. This will be found to be delicious. To make it more palatable still, roll each slice of liver round a piece of bacon and a slice of truffle, and tie or skewer the roll together. This is easy to do in Italy, where truffles are almost as common as mushrooms. In England only the wealthy few can indulge in truffles—and those may not care to eat fried liver, even for breakfast. Stuffed with truffles, however, it is not unfit for Royal stomachs." FRITTO MISTO—(2) "This fry is an odd medley, and is composed of the following ingredients, which must all be dipped into batter, fried in lard, and served in the same dish: Ran's kidneys, which have been soaked in salt water, pieces of bread, tendons of veal, calf's brains, sweatbreads, rice croquettes, pieces of cauliflower, egg-plant, anchovies, and artichokes." FRITTO MISTO—(3) The ingredients of the mixed fry are varied with the seasons or according to taste. This one has for its components: lamb fries, sweatbreads and egg-plant, bread-crumbed and fried; calf's brains, calf's liver and cauliflower dipped in batter and fried; all dished together with fried parsley and lemons. COTELETTE MILANAISE—"In an Italian restaurant we recently came across a table specialty which may be recommended as an appetizing entrée. We refer to *cotelette Milanaise* with curry sauce. The ordinary *cotelette Milanaise*, consisting only of a veal-chop or cutlets encrusted with bread-crumbs and egg, with the traditional quarter of a lemon to stimulate the palate, is a common dish enough, but the addition of curry sauce gives it a distinct excellence." ITALIAN DISHES—*Le Restaurant Italien* makes a specialty of Italian dishes, and on its carte figure prominently the names of *Lasagne*, *Ravioli*, *Tagliarini*, *Spaghetti* and *Risotto*, besides the famous *timbales* of Milan, and the filling, if not particularly tasty, *polenta*, a kind of porridge made of maize-flour. POLENTA—Is also made of chestnut-flour. "The food made of the chestnut which is most in favor is the *polenta*. This is made by simply boiling the chestnut-flour 10 or 15 minutes with a little salt to flavor it, taking care to keep it constantly stirred. This is eaten with cream, and is said to be very healthy and nutritious." NECCI—"The food called *Necci* is composed of chestnut-flour formed into a cake, and is made by first mixing the flour with cold water, and then making cakes piled one upon another and separated by chestnut-leaves

## ITA

moistened with water. The whole mass is then cooked over a hot fire, and the cakes are taken off one by one when the leaves are almost burned, and are then eaten with cream and butter. ZABBAGLIONE—Is the name of an Italian sweet *entremet* to be had in perfection at the Hotel d'Italie. It is composed of whipped yolk of egg sweetened, and mixed with 'Capri' or some other white wine, and is served in a frothy mixture in cups." POLPETTI—Croquettes of meat of any kind mixed with grated cheese stirred over the fire with a thick sauce and seasonings, rolled and shaped when cold; breaded and fried. ITALIAN MERINGUE—Boiled icing, made of 1 lb. sugar boiled to the crack and 6 whites whipped very firm stirred in; used to ice cakes and to dry bake as "kisses," also to mix in frozen punch for punches *a la Romaine*. ITALIAN PASTES—Those well known everywhere are macaroni and vermicelli; others are *tagliarini*, *spaghetti*, *fidelini*, *lasagnes*, and various small kinds and shapes; they are all essentially of the same substance, but of different qualities, some being made of the best wheat-flour, some with a proportion of corn-flour. ITALIAN SOUPS—Generally those soups which contain or are served with some form of these pastes, and with grated cheese handed around separately. ITALIAN RAVIOLIS—Little turnovers made of balls of chicken forcemeat size of a grape, inclosed in nouilles paste; poached in water, placed in a dish with grated parmesan and sauce; served on same method as a *garbure*, with soup in another tureen, to be taken up and eaten with the soup. SARDINIAN RAVIOLIS—Instead of chicken forcemeat they are filled with a paste made of spinach, eggs, bread-crumbs, cheese, and butter. LASAGNES A LA MILANAISE—Lasagnes boiled, mixed in a sauce or ragout of gravy, cheese, mushrooms, truffles, tomato sauce, etc. NOQUES—Italian-paste dumplings; equivalent to the German *klöse*—made of equal weights of eggs, butter, and flour worked together, dropped by spoonfuls in boiling water; eaten with grated cheese and butter, or with soup, or finished as macaroni, etc., in the oven. AGNOLOTTIS—Another variety of *raviolis*, made the same except the filling is of minced cooked beef with cheese and fried onion; served aside with soup, or in cheese, sauce and butter baked. GNOCCHIS—Paste balls like *noques*, but differently made; of 5 oz. flour in  $\frac{1}{2}$  pt. boiling water, tablespoonful butter, 1 oz. cheese, 3 eggs; similar to cheese fritters; poached, finished like macaroni and cheese; baked. Another variety has pounded chicken meat mixed in the paste. TIMBALE A LA MILANAISE—A kind of macaroni raised-pie; the macaroni boiled, mixed with truffles, mushrooms, red tongue, and cream sauce; baked in a mould lined with short paste; turned out whole. RISOTTO PIEMONTAISE—Rice fried raw with onion in butter; boiled in broth sufficient, with butter and cheese; served aside with soup. RISOTTO NAPOLITAINE—Rice as above, with tomato sauce, butter, cheese, mushrooms, etc.; served alone or with soup. ITALIAN PYRAMID—Rings of puff-paste of decreasing sizes baked separately, piled

## ITA

on each other with marmalade spread between; ornamented. ITALIAN CREAM—Yellow cream-custard strongly flavored with cinnamon, with whipped cream added, and gelatine about 1 oz. to each quart to set it in a mould. ITALIAN PUDDING—A deep dish lined with puff-paste, layer of half-cooked slices of apples on the bottom; sugar and wine; bread-custard to fill up; baked. (*See Flan.*) ITALIAN STEAMED PUDDING—Panada of bread-crumbs in boiling milk mixed with sugar, yolks, vanilla, raisins, whipped whites; it rises like a soufflé when steamed; to be served immediately, with sabayon (*zabaglione*). OTHER ITALIAN DISHES—Ices, salads, and sauces, may be found in great numbers in all cookbook directions; they may be known by the appellations *Medicis* (Catherine de Medicis introduced Italian cookery into France), *Napolitaine Romaine*, *Sicilienne*, and all such allusions to Italian cities. ITALIAN ANTE-PASTO—Signifies the entire list of appetizers or cold *hors d'œuvres*. See also *Ices*, *Granito*, *Grissini Bread*, *Macaroni*.

ITALIAN WAREHOUSE—"The Italian warehouse, first established in London in the reign of Charles II, is an institution peculiar to the British Metropolis. In the last century, when a gentleman went to Italy, he generally resided there for at least six months. When he returned and settled down in his grand town mansion, he was not satisfied with having a French cook; he sighed for the *macaroni* and *vermicelli*, the Parmesan cheese, the *polenta*, the *morta-della di Bologna*, the *Lacrima Christi*, and the *chianti*, and especially the pure olive-oil of Florence and Lucca. It was to supply his lordship or his honor with such articles that the Italian warehouses were founded and grew apace. The Italian warehousemen of the past, however, dealt in other commodities besides wine and oil, macaroni and cheese. They were as useful to my lady as to my lord; they imported from Italy lute-strings—a corruption of *lustrini*—and *paduasoy's*; the rich cut velvets of Genoa; the stiff black silks and splendid lace—a legacy from the Spanish domination—from Milan, with beads from Venice, and gloves and coral from Naples." The Italian warehouse may be found in most of the large cities of the United States, and there the steward finds his foreign cheeses and all such specialties as are raised above the ordinary public demand by their prices.

ITALIENNE SAUCE—Brown or white sauce with wine, shallots, mushrooms, etc. (*See Sauces.*)

## J.

JACKET KETTLES—Double-bottomed kettles or boilers, steam from the engine-boiler is let into the space between the bottoms and rapid boiling is the result. Used for soup stock boilers, ham boilers, vegetable boilers and for laundry purposes..

JAM—Fruit stewed down with sugar; applied to mashed fruit. The fruit stewed down without breaking up the shape is called preserves. All

## JAP

fruits are reduced to jam except the orange which has a name to itself; orange jam is called marmalade. JAM TARTLETS—(1)—Patty pans lined with puff-paste, a spoonful of jam in each; baked. (2)—Patty cases or vol au vents, cut out of puff-paste with a center to be taken out and the vacancy filled with jam after baking. JAM ROLY-POLY—A pudding made of a sheet of short paste or biscuit-dough spread over with jam, rolled up long, steamed or boiled in a cloth. IMITATION JAM—"Recently there appeared a cutting from an American paper explaining what a certain American firm understood by blackberry jam! There is a company here that runs them close in the matter of sharpness. You know that moss or dried grass, with which Chinese exporters pack up their fragile wares. It is glutinous when boiled, and costs nothing. Your Chinese importer will give it to you if you will cart it off his premises. Add glucose, flavoring essence, and little dye, and there you are, with first-rate raspberry jam; prime cost, one centime a pot, to be retailed at sixpence a pound." SOME GENUINE JAM—The scarcity of raspberries in the fruiterers' shops and on the huckster's barrows is accounted for by the insatiable demand of the jam manufacturers, who buy all they can get of this delicious fruit. In the Borough market recently Messrs ——— of Stratford, took a "parcel" of 20 tons at \$95 per ton.

JAMBALAYA—Southern or creole dish made in two or three different ways. (1)—Fried chicken cooked and placed in a dish is bordered with rice stewed with tomatoes, onion, butter, spoonful of sugar, salt and pepper, till the rice is tender and all stiff enough for a spoon to stand in it. About the same as Rissoto with chicken. (*See Ital an cookery.*) (2)—American planter's way. Ham cut in dice, lightly fried with butter and onion; rice and water added and red pepper, and all stewed together till rice is done and dry, the pieces of ham being of course mingled in the rice. (3)—Florida Spanish. Pieces of fish, ham, onion, fried together; tomatoes, water and seasonings added; rice boiled in it sufficient to nearly dry it up.

JAMBON (Fr.)—Ham. JAMBON DE PORC—Pork ham. JAMBON D' OURS—Bear ham.

JAMBON, SAUCE—Brown sauce with shred ham, shallots, butter, wine, cayenne.

JAPANESE COOKERY—The natives eat little flesh. Only since the advent of foreigners have they learned to eat any at all. Their sustenance is drawn mostly from rice, sweet potatoes, fish and a few vegetables, such as a great radish called *daikan*. The lesser articles are barley, wheat, green corn, oranges, grapes, figs and persimmons. They make a soup of rice, small pieces of dough, a little sea-weed, some snails and sharks' fins. METHOD OF FRYING — In the country towns tell them to cook you a chicken; you hear a squawking in the house, and in just five minutes the bird is before you, all cooked. It is done in this wise: Upon



## JAP

a charcoal fire are placed thin copper pans, which are almost instantly heated to a white heat; oil is dropped in, the chicken on top, and it is done. THE JAPANESE MISOSHIRU—In the eating-houses of Tokio, if he can obtain the concession of a spoon instead of being obliged to drink his soup out of the bowl like tea, as the natives do, the adventurous foreigner will find that he has in the first dish set before him a savory compound called *misoshiru*. This is made from *miso*, a fermented mixture of soy, beans, wheat, and salt. It has a gamey flavor all its own. He will then attack with pleasure or surprise the many little plats on his tray, turning for relief from the *sweetened white beans*, mixed with *Kawatake*, a kind of mushroom grown in the shadows of rocky boulders, and the delicious lobster pudding or cold omelet and other trifles included under the head of *Kuchitori*, to the *Hachimono*, which may happen to be a piece of sole stewed in soy, or a block of salmon with lobster and shredded cucumber. Then for a change he may, with the pair of wooden chop-sticks which are laid before him on a bamboo tray, divert himself with trying to pick out of a small china cup, made without a handle, the brown soy-colored beans and strips of *Kikurage*, or ear-shaped mushrooms. Boiled rice is served in a separate bowl. Another substantial dish, *Wanmori*, consists of meat or fish and vegetables, possibly, for instance, a piece of fresh salmon and a slice of vegetable marrow with pieces of soaked *Fu*, a kind of biscuit made from the glutinous part of wheat flour. The gravy in which these *pieces de resistance* are floating is thickened with a transparent, starchy substance, obtained from the root of a climbing plant (*Pueraria Thunbergiana*), called by the Japanese *Kuzu*. For salad there are thin slices of cucumber flavored with scraped shreds of dried bonito, a fish much in favor on the Pacific coasts, the cucumber being dressed with vinegar and sugar, but without oil. One other relish must be noticed, the sliced root of the burdock salted and preserved in *miso*. A sweet kind of *sake*, described as Japanese wine, is the proper beverage at the meal. After dinner Japanese green tea may be ordered, or, upon special application, a cup of fragrant cherry-flower tea. To prepare this drink half a dozen dried blossoms and buds of the cherry flower are placed, with a pinch of salt, in a tea-cup, and hot, but not boiling, water poured on them. The infusion is slightly and agreeably aromatic.

JAPANESE CROSNES—See *Crosnes*. “*Crosnes Japonaise*, the new vegetables, are now to be seen and bought in every green-grocer’s and delicacy-warehouse in Paris, and seem to be very popular. The growers supply the trade with printed cards giving very full instructions as to the different ways of cooking the vegetables.”

JAPANESE PLUM—A variety of plum recently acclimatized in Florida and suited to the climate. It is eaten raw, and made into preserves.

## JEL

JAPANESE PERSIMMON—A newly introduced fruit of the southern Gulf states and California. It is in appearance much like a tomato. It must be perfectly ripe when picked, otherwise the flavor is not agreeable; this renders it unsuitable to ship to distant markets. It can be dried, however, like a fig, which it resembles in its dried state, and has a very meaty, pleasant taste.

JAPANESE SALAD—*Salade Japonaise*. See *Salads*.

JAPAN PEA—A prolific sort of field pea cultivated in the western states.

JAPANESE PAPER NAPKINS—Paper napkins, either plain or bordered or figured, can be bought at the notion stores at prices ranging from 50 cents to \$1.00 per 100. They are useful for picnic and festival purposes, for large catering affairs and out-door spreads. At one of the large catering undertakings mentioned in the third division of this book the contractors provided 2,000 linen napkins; a needless expense, for they had to resort to paper napkins after all on account of the want of time for laundering the first supply.

JARDINIER (Fr.)—Gardener.

JARDINIÈRE (Fr.)—Mixed vegetables; a garden stand for plants or flowers. SALADE JARDINIÈRE—Salad of mixed vegetables. CONSOMME A LA JARDINIÈRE—Clear soup with various vegetables cut into small fancy shapes. GARNISH A LA JARDINIÈRE—Carrots and turnips cut in shapes like large peas, with a scoop made for the purpose, string beans, cauliflower, green peas, asparagus tops or any vegetables, all of corresponding small size, cooked in seasoned broth, then tossed in glaze or meat gravy. DISHES A LA JARDINIÈRE—All dishes of meat which are served up with the *jardiniere* garnish around them or in the center.

JARDINIÈRE CUTTERS—There are small machines to be bought which rapidly stamp out patterns from slices of vegetables for *jardiniere* garnish and soups.

JAUNE MANGE—Like blanc-mange, but made yellow with yolk of egg or saffron; a custard set with gelatine.

JELLY—Table jellies are made of gelatine, sugar, flavorings, and either water and fruit juice or water and wine. Rule: 1 qt. water or juice, 1½ oz. gelatine, 2 lemons, 8 oz. sugar, all boiled together, then strained. By adding white of eggs before boiling it can be made brilliantly clear and can be colored to any desired tint. Set in moulds in a cold place until firm and solid, then turned out on a dish covered with a folded napkin. GELEE DE FRAISES—Strawberry jelly colored red with whole strawberries in it. GELEE DE MURES SAUVAGES A LA CREME—A border mould of blackberry jelly, with whipped cream in the center. GELEE A L’ANANAS—Pineapple jelly, with pieces of pineapple in it. GELEE AU JUS DE GRENADES—Pomegranate jelly.

## JEL

GELEE A LA MACEDOINE DE FRUITS—Maraschino flavored jelly with whole fruits in it. GELEE A LA CHARTREUSE—Jelly flavored with chartreuse liqueur. GELEE DE DANTZIC AUX FRAISES—Cherry-brandy jelly with whole strawberries. GELEE DE MARASQUIN AUX ABRICOTS—Maraschino jelly with halves of apricots in it. GELEE AU CURACAO—Curaçao jelly. GELEE A LA PANACHEE—A mould of two or more colors of jelly in layers; ribbon jelly. GELEE AUX VIOLETTES PRINTANIERES—Jelly flavored with an infusion of spring violet-flowers in syrup; orange-flowers are used the same way. GELEE A LA BACCHANTE—Green jelly made with the juice of green grapes and spinach, sugar and champagne. GELEE A LA RUSSE—Jelly whipped to a froth while cooling on ice, then moulded. GELEE MOUSSEUSE A L'EAU DE VIE—Whipped jelly with brandy. GELEE FOUETTEE AUX FRUITS—Whipped jelly with maraschino and small fruits. WINE JELLY WITH WHIPPED CREAM—A very acceptable combination of gelatine jelly made with one-third sherry or any good wine; served in saucer of whipped cream, or in a whole mould with whipped cream

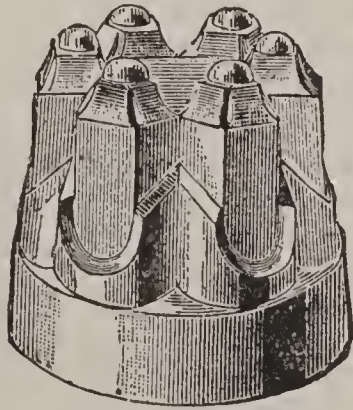

JELLY MOULD,

And for puddings, aspics, creams, or ices.

around it. BORDER JELLIES—Border moulds are made; the outer rim to be filled with jelly and turned out when set, the well in the center of the jelly filled with whipped cream and perhaps strawberries and other such additions. JELLY WITH ICE CREAM—Same plan as with whipped cream and best in hot weather. GELEES VARIEES—All jellies named for some fruit or liqueur are either made with a proportion of the juice of the fruit, or with pieces or slices set around the mould; or are flavored with the liqueurs; as benedictine, kummel, anisette, kirschwasser, etc. GELEE A LA PARISIENNE—Fancy form; specialty. Two jellies, one colored pink and flavored with strawberry; other uncolored, flavored with kirschwasser; both portions whipped on ice, and before set filled into the mould in alternate layers or portions; turned out on ornamental stand of candy. GLASSES OF CHAMPAGNE—Fancy form; specialty. Clear, bright jelly filled in glasses in liquid state, whipped jelly on top; made cold. GLASSES OF ALE—Fancy form; specialty. Clear, brown jelly vanilla-flavored, filled in slender ale-glasses in liquid state, more jelly whipped to foam and piled on top.

## JEL

SOUFFLE JELLIES—Same plan as preceding, but red wine-jelly set solid an inch deep in a pan; foam of whipped jelly and white of egg flavored with maraschino spread an inch deep on top when the first is set; all made very cold, cut out in blocks and served in glass-plates. INDIVIDUAL JELLIES—There are moulds of all sorts and patterns to set jellies in, one mould to be served to each person. TRI-COLORED JELLIES—Set in small moulds, three kinds and colors of jelly or two jellies and one *blanc mange* or *jaune mange*; taken out of the moulds, cut in three downwards, the sections wetted with melted jelly, replaced in the moulds, one section of each color in each mould. (*See Syllabus, Aspic, Pain de Peches.*)

JELLIES, FRUIT—The other class are the fruit-jellies, made and eaten as preserves. *Rule:* One pound sugar to each pint of expressed fruit-juice, boiled together till the fruit sets as jelly, when immersed in cold water or set on ice to try. Used to eat with meat, as currant-jelly with mutton and venison, cranberry-jelly with turkey, and to spread in jelly-cakes, fill tarts, etc..

JELLIES, IMITATION—Made of (1) 1 pt. water,  $\frac{1}{4}$  oz. pulverized alum, boiled a minute or two, 4 lbs. white sugar, boiled a short time, strained, colored variously, flavored with oils or essences to imitate fruit jellies. (2)  $3\frac{1}{2}$  lbs. commonest gelatine in  $2\frac{1}{2}$  gals. water with 30 lbs. sugar, boiled until gelatine is all dissolved, colored as desired,  $\frac{1}{4}$  oz. tartaric acid added, taken from the fire, dissolved, flavored, allowed to get cold in pails or glasses. Makes 50 lbs. Glucose also is largely used in making bogus jellies, and the jams and preserves of the same class are made fruity with shredded turnips boiled in pineapple-flavored glucose. "A year or two since a man found himself with a large crop of red currants, and he manufactured them into "jam," or "jelly," using the best of sugar, and producing a most excellent article. He found the hotels supplied with a heap, impure article, manufactured from glucose and acids and colored to resemble somewhat in color and taste currant jelly, which could be procured at retail even lower than he could afford his at wholesale. The result was the enterprising man had a large quantity left on hand. But we haven't heard of his manufacturing any more 'pure currant jelly' for market. A few years since a gentleman in Union village started the manufacture of apple-jelly, and he produced a very pure and delicious article, which should have commanded a ready sale at hotels, bakeries and in families, for the table and for pies, tarts, etc. But the business did not prosper, we think. At all events it was suspended. An inferior article, made up largely of adulterations, which 'answered the purpose,' took the trade." BOGUS JELLIES—An American physician tells how the cheap jellies which some bakers put into their tarts and jelly cakes are made, as follows: Take 4 qts. water and  $\frac{1}{2}$  lb. alum; boil 2 minutes, add 32 lbs. of white sugar; boil 5 minutes longer, strain while it is warm (and the hotter it is strained the easier)

## JEL

through a coarse towel; when nearly cold, add 2 ozs. of acetic acid, and  $\frac{1}{2}$  lb. of real currant jelly. When cool, pack it in tumblers. If you desire a vanilla jelly, add in place of currant jam four 25-cent bottles of extract of vanilla, and stir when nearly cold. If you desire strawberry jam, prepare the alum and sugar as before, and add  $\frac{1}{2}$  pt. of essence of strawberry. Or if lemon is desired, add essence of lemon. You can make what you like with these proportions of alum and sugar. "This is the way to make the grocers' jelly and jam that are placed in the confectioneries and bakeries."

**JELLY CAKE**—Two, three or more thin sheets of genoise or pound or other cake spread with jelly and placed one upon another. **JELLY SLICES**—Several fancy forms of sliced jelly cake iced or ornamented. **JELLY PIE, SAVORY**—Deep dish with hard boiled eggs in bottom and slices of fowl, etc., seasoned with crust on top, filled with meat jelly; eaten cold. **JELLY PIE, SWEET**—Fruit jelly and custard mixed together; baked in a crust. **JELLY PUDDING**—A bread custard or corn-starch custard baked, spread over with jelly, and meringued; same as queen pudding and Oswego pudding. **JELLY ROLL**—Thin sheets of sponge cake spread with jelly, rolled up, wetted with syrup, rolled in sugar.

**JERSEY PUDDING**—Boiled pudding, made of 2 oz. ground rice, 1 oz. flour, 2 oz. sugar, 4 oz. butter; all worked together; 2 oz. chopped raisins, grated lemon-rind, 3 eggs, 2 spoons milk; well mixed; boiled in a mould 3 hours; lemon sauce.

**JERSEY WONDERS, OR CAKES**—Crullers; a rich and crisp sort of doughnuts not made with yeast, not very light; in the form of strips tied up in a knot made of (1) One pound sugar,  $\frac{1}{2}$  lb. butter, 6 eggs,  $\frac{1}{2}$  pt. milk, 2 teaspoons baking powder, flour to make dough of it; (2) Another less rich, of 6 oz. sugar, 6 oz. butter, 8 eggs, a glass of brandy, flavoring extracts, 2 lbs. flour; made into dough; cut in strips, or shapes, or rings; fried in hot lard.

**JEWISH COOKERY**—While the Jews do not excel in high-class cookery, perhaps on account of their restrictions in regard to materials, what they have is essentially good and of a wholesome character. The religion of the Jews provides that its followers shall observe certain customs, amongst which those relating to foods are particularly stringent and have evidently been drawn up with extreme care. Diseased materials, meals which cannot be easily digested, or which are liable to be diseased, such as veal and pork, are discountenanced. The meat must moreover be thoroughly cleansed, and fish is strongly recommended as an adjunct to a generous feast of vegetables and fruit. At least once a year the subject of Jewish cookery and its peculiar restrictions is brought to the consideration of the stewards or caterers of the generality of hotels on the approach of the Jewish Feast of the Passover, which partakes of the nature of a fast as well as a feast, or a fast before the feast, on account of the re-

## JEW

striction in the case of the bread and pastry which may be eaten at that time, and it becomes embarrassing when perhaps a Jewish rabbi and members of his congregation live in the hotel if their particular requirements at that season cannot be provided for want of the requisite knowledge. Passover-week, the great feast held by the Jews all over the world to commemorate their deliverance from the land of bondage 5,000 years ago, occurs in the spring, near the time of the Christian Easter, generally before it. The law of Moses forbids them to do any servile work during that week. The reform Jews hold high festival only on the first and last days; orthodox Jews observe four days. On the other days servile work may be done; but all Jews must abstain from eating leavened bread. Pastry containing flour is denied them, but they substitute it with potato meal, and they are prohibited from drinking malt liquors or spirits which are made from grain. On the eve of the passover they hold solemn religious services, after this comes the great feast, and such is the lavishness of the Jews at this season they lay their tables with all the delicacies their religion allows them; and all Jews, whether master or servant, rich employer or poor menial, sit at the same table and partake of the same fare. This is to remind them that in Egypt they were all slaves and equal. **EMBLEMATIC BASIN**—Among other curious observances one consists in the head of the family having set before him a dish containing a roasted shankbone of a lamb, a large stick of horse-radish with the top on, a bunch of chervil, mustard and cress, a roasted egg, almonds, cinnamon, raisins, smashed up together and pulverized in a species of mortar. This is an important rite. The shank of the lamb symbolizes the Passover lamb; the roasted egg commemorates the festival egg; the bitter herbs recall the bitter lives of the Israelites in Egypt; and the bruised rasins, almonds and wine represent the mortar which their ancestors used in making bricks for the Pharaohs. **JEWISH BUTCHER'S MEAT**—An extra supply of *kosher* meat is required at the Passover season, and the Jewish butchers' shops look like our butchers' shops at Christmas. **THE SHOCHET**—The man who kills the animals is called a *shochet*; he puts his seal on every animal that is *kosher* (pure), but if the least spot or blemish is discovered—although it does not in the least detract from the quality of the meat—the official seal is withheld, and the "unclean" articles must be consumed by Gentiles. As is known generally, the Jews are forbidden to use the blood of any meat, and very particular methods are employed at the slaughtering of *kosher* animals to prevent any blood remaining in the carcase. Shell-fish were once forbidden to the Jews; pork is forbidden alike to Jew and Mohammedan. **PASSOVER SOUP**—Beef soup with vegetables and *motsa* balls, like *quenelles*, *noques*, or *klöse*. Made of 4 lbs. beef and a skin bone and calf's foot, carrots, turnips, celery, fried onions, sweet herbs, pepper, salt, sim-

## JEW

mered 8 hours, strained, freed from fat. **MOTSA BALLS**—Cracker dust 8 oz., suet 2 oz., eggs 4, salt, pepper, ginger, nutmeg. Worked up to a paste, made in balls, boiled in the soup. **JEWISH STEWED FISH**—Served cold. Sliced onions are simmered till done in water, with butter, pepper and salt, pieces of fish on top of the onions, covered and stewed till done. Liquor strained off, juice of 2 lemons, and 3 beaten yolks mixed in, and heated till thickened custard-like without quite boiling; poured over the fish in a dish; parsley. **JEWISH FRIED FISH**—One of the great delicacies of the Jewish festival season is fried fish. Where the Jewish community is sufficiently numerous to support a fried fish shop but little fish is cooked in private houses, but these shops supply all, making a specialty of the trade of frying, like the Roman fry-shops or the Parisian *rotisseries*, or meat roasters for the public. One such shop in Middlesex street, London, has been established over 200 years. Salmon, halibut and soles are the kinds of fish preferred, and enormous quantities are sold. From these fry-shops the cooked fish is sent to the residences of the wealthy Jews, and not only that, but to the hospitals for Jewish patients and to the prisons for Jewish delinquents. **HOW IT IS COOKED**—After being cut into pieces, the fish is dropped in a basinful of battered eggs, then coated with *motsa* meal made of crushed Passover cake and then fried in salad oil. This system of cooking in oil is not an original habit of the Jews. They carried it with them from Spain after the Inquisition. They seldom eat fried fish hot, they prefer it cold. **JEWISH SMOKED MEAT**—Is prepared by the Jewish butchers and can be bought of them. Is cooked by parboiling, then taking up, skimming the liquor and cooling it, and putting back the meat and gently steaming till quite tender; served with vegetables. **CHORISSA**—Jewish sausage; is prepared by the Jewish butchers; is boiled and braised, served with rice. **PASSOVER FRITTERS**—*Motsa* meal (cracker dust) eggs and little sugar worked to a stiff batter, fried by spoonfuls in hot oil. Eaten with syrup or sugar. **JEWISH APPLE FRITTERS**—Same as the preceding with chopped apples in the batter. **JEWISH ALMOND PUDDING**—Sort of almond soufflé, made of 1 lb. almonds crushed, 2 oz. bitter almonds, 1 lb. powdered sugar, 14 eggs, 6 yolks more, 3 tablespoons orange flower water. The eggs, water and sugar beaten together 20 minutes, same as sponge cake, the powdered almonds added instead of the flour which would be in sponge cake; baked. **JEWISH MOTSA PUDDING**—About a pound of Passover cakes (water crackers) soaked in water, squeezed, made up into a plum pudding with the usual fruit and suet, either boiled or baked. **PASSOVER ROCK CAKES**—Made of  $\frac{1}{2}$  lb. butter,  $\frac{1}{2}$  lb. sugar,  $\frac{1}{4}$  lb. each *Motsa* meal (meal of crushed water-crackers) and currants, 2 oz. ground almonds, 4 eggs. Worked up to cake dough with more meal if necessary; rough lumps like rocks dropped on pans, stuck over with blanched almonds;

## JOH

baked. **JEWISH PASSOVER CAKE OR MOTSA**—There is not much taste in a Passover cake, huge pyramids of which are piled up in the Jewish bakers' and grocers' shops. There is in Amsterdam a factory engaged in the production on a large scale of passover or unleavened bread. Although the consumption does not last more than a week, the factory is busy from the end of November or the beginning of December till Eastertide. A large portion of the goods is exported to other countries. The *motsa* consists of a large round thin cake about 15 inches in diameter, made simply out of flour and water well kneaded, and baked to crispness; it must not contain yeast, powder, shortening, nor any raising ingredient. There are two varieties; the *motsas* are larger than pancakes, and thin as wafers. Great precaution is taken to obtain the proper sort of flour. The authorities of the different synagogues combine on this occasion, get the flour especially ground, and license men to sell it. The price is specially put in order to have a surplus for the poor. **THE MITZVEHS**—Are thicker. Passover cakes eaten on the first two nights of the festival. They are thick enough to be split open and toasted, or soaked in milk and fried. **MOTSA MEAL**—It will be observed that the use of *motsa* meal or crushed almonds in any sort of cake or pudding is a substitution for flour which is forbidden to be used in pastry at the Passover season; otherwise the pastries are not peculiar or special. The thin *motsas* are hard water-crackers in effect, and to make the meal they are rolled to dust and sifted. **PASSOVER DRINKS**—A special department is set apart by Jewish bar-keepers for Passover drinks, which, as has been stated, must not consist of anything made from grain—the 'corn' of the bible meaning all kinds of grain.

**JOHN DORY—JEAN DORE or SAINT PIERRE**—A sea-fish common in French and English markets, of singular appearance and excellent quality. "On the Brittany coast, crabs, dorys, mullets, and fifty other varieties are plentiful. The dory is here called



JOHN DORY, JAUNE DORE, OR SAINT PIERRE.

*la bete du bon dieu*, it being a superstition that it was the first thing in the waters under the earth that was created, the round black marks on the sides being supposed to be the traces of the Creator's fingers." **JEAN DORE A LA CREMERIERE**—Boiled in milk and water; served with sauce of cream, butter and lemon

## JOH

juice. **JEAN DORE EN MATELOTE MARINIÈRE**—Dory baked, and served with oyster sauce. **JEAN DORE A LA BATELIERE**—Dory boiled; served with button-onions, mushrooms and essence of anchovy in white sauce. **JEAN DORE A LA PUREE DE CREVETTES**—Dory cut up and stewed; served in a purée of shrimps with butter and Béchamel sauce. **DORY BOILED**—The fins are cut off, the fish placed in a fish kettle with 3 oz. salt to 1 gl. water; the water brought to a boil gradually and simmered till the fish is done; served with caper sauce.—The name is said to be a corruption of *Faune*, yellow. *Dore* is golden.

**JOHNNY CAKE**—American common name for any sort of plain corn-bread; originally a cake of corn-meal, salt and water baked on a board set up before an open fire.

**JOLIE FILLE SAUCE** (Fr.)—Fair maid's sauce. White chicken-sauce with hard-boiled yolks, bread-crumbs, butter, and parsley.

**JORDAN ALMONDS**—Best quality of table-almonds.

**JUBILEE PUDDING**—(1) A border-mould of claret jelly, center filled with whipped cream mixed with cut candied fruits and preserved ginger. (2) A hot vermicelli-pudding made like a bread-custard and baked; strawberry jam and cream spread on top, and meringued over—like queen pudding.

**JUMBLES**—Small ring-cakes, various qualities; best made of 1 lb. sugar, ½ lb. butter, 8 eggs, lemon flavor, flour to make soft dough; forced through a star-tube in rings on paper; baked.

**JUNKET**—English dish of cream and milk curdled with rennet and flavored with brandy; eaten with short-cake. The cream is whipped and spread on top of the curd.

## K.

**KALE**—Sea-kale, a kind of cabbage-greens, like cabbage in taste, like endive in appearance; obtainable early in spring when other vegetables are scarce; should be partially blanched by the gardeners by being grown under cover, as the whitest is the best and tenderest. Cooked like spinach and other greens.

**KABOBS OR KEBOBS**—Meat in slices cooked on skewers. It is English or Anglo-Indian. The method is followed extensively in this country, but the word is not used; we call kebobs *brochettes*. Kebobs or brochettes of meat of any kind have either two kinds of meat or something between the meat, as a slice of liver and bacon alternately is kebobsed liver, slices of pork with a piece of onion between each slice is a pork kebob, mutton chops egged and breaded, then a skewer run through the whole bunch, with perhaps a slice of fat salt pork between each chop, is another form of kebob or *brochette*.

**KANGAROO TAILS**—These can be bought in cans. To prepare for the table the can is warmed,

## KID

the jelly and gravy drawn off and made into a hot sauce with port wine and seasonings, strained, the pieces of tail put in it; served with *croutons* of fried bread around.

**KARTOFFELN** (Ger.)—Potatoes.

**KEDGEREE**—Anglo-Indian term like kebob. It means "twice cooked." Is not any one thing but a *rechauffe* or warm-up of fish, eggs or meat with rice or potatoes or boiled peas. (1)—Cold fish and hard-boiled eggs cut up in butter, baked on a layer of mashed potatoes till all are hot through. (2)—Hard boiled eggs and fried onions mixed, and served on a bed of porridge made of boiled peas and boiled rice, mixed together with butter, etc.

**KID**—Young kid is as freely purchased and eaten in some sections of this country as young lamb and is as good. It is often, however, sold for lamb, which is a fraud on the buyer. **TO KNOW KID FROM LAMB**—Observe the lower joint of the fore-leg; the goat's leg from the knee to the hoof is one-third shorter than the sheep's. If the lower joint is cut off by the butcher there is no way of knowing the difference, but it is the common shop practice to dress lambs with all the fore-leg left on except the hoof, and to do otherwise in the kid season will be a suspicious proceeding. **CALIFORNIA KID**—"The editor of the Los Angeles *Herald* asked me how I would like to go out some day and help him eat a kid. I had never eaten any kids, but I did not want to show my ignorance, so I told him I should like it above all things. I thought maybe there was a time here when the people thought they must eat a kid or two, and I did not want to stop their pleasure, so I agreed to go. I thought maybe if I did not like the kid, when the time came they would let me lunch on a harness tug or something. He set Sunday as the day, and the result is I am just about as full of youthful goat as a man can be, and if I don't bleat before morning it will be strange. Lynch has a friend who keeps an Italian restaurant, where everything is cooked right. Once a year or so he secures a young kid and keeps it until it is about six weeks old, feeding it on nothing but its mother's milk. It never eats a spear of grass and is simply fed on milk. The kid is taken off into a canyon, away from the vile city, beside mountain streams, killed and dressed and cooled, and placed on sticks over the embers of a fire, and roasted, being basted and turned frequently, and when done to a turn it is placed upon an improvised table, camp fashion, and the happy, hungry man who has an invitation to that dinner begins to get to his work. I had wondered, all the way, whether I could eat goat. I had thought of all the goats I had ever met around livery stables, and could remember just how they smelled, but when I first got a smell of that cremated kid I wondered if there would be any of it left for the rest of the party. I have eaten many delicious dishes in my time, but I never ate anything so delicious as the kid of to-day, roasted by my Italian friends and aided by some Los

## KID

Angeles claret and plenty of mountain air, while the mountain stream at our feet sang so joyously, and I will go further to enjoy another half of a small goat, if I ever get the chance, than to partake of any meal that can be produced." GOAT MUTTON—"A fine billy-goat, weighing 56 lbs., formed the gastronomic feature of a feast recently given by the proprietor of the Duke of Lancaster, Royton, Lancashire. About fifty guests sat down to supper, and according to a local chronicler, 'there was but one opinion expressed at the finish of the appetizing meal, that the flesh of the animal partaken of was equal in all respects to the finest Southdown.' Kid's flesh, we know from personal experience, is not half bad, but the thought of billy-goat in his prime is too appalling."

KIDNEYS—Mutton kidneys are a great breakfast specialty in England; grilled kidneys are only prevented from being as universally served as the national eggs and bacon by their dearness; the demand is always greater than the supply, and the price is high, accordingly. Australia, which exports so much mutton, now sends to England sheep-kidneys in a frozen state, and the coveted delicacy may soon be obtainable by people of moderate means in consequence. BROILED KIDNEYS—The kidneys skinned are cut open without quite severing the two halves, and a thin skewer run through them edgewise to keep them in flat shape for broiling; dipped in butter, laid on gridiron cut-side down; broiled 3 minutes; turned, and broiled 3 minutes more; served with *maitre d'hotel* butter. HOW TO EAT KIDNEYS—"Kidneys should be eaten directly they are dressed, else they will lose their goodness. They are also uneatable if too much done, and a man that cannot eat meat underdone should not have them at his table. In France they are *saute* with champagne or chablis." MUTTON KIDNEYS WITH MUSHROOMS—Sliced kidneys fried in a pan with butter till slightly brown; sliced mushrooms added, and brown sauce, lemon juice, butter, salt, pepper, parsley. STEWED KIDNEYS—Any kind; same as the preceding without brown sauce ready; but flour stirred in, and water added; simmered to thicken. KIDNEYS IN CREAM—Beef, veal or mutton kidneys parboiled in two or three waters to get rid of the brown gravy that comes from and curdles on them; chopped fine, put into cream sauce with parsley. BROCHETTES OF KIDNEYS—Slices strung on a skewer, *saute* in a pan with butter, or in the oven, and finished on the gridiron; served on the skewer if it is silver, or slipped off the skewer on to toast, and sauce poured over. SAVORY BUTTER FOR KIDNEYS—One pound butter, 6 oz. finely chopped shallots, 4 oz. chopped parsley, pepper, salt, lemon juice; worked together. FRIED KIDNEYS AND SALT PORK—Equal number of slices of each; fried together, and gravy made in the pan. CURRIED KIDNEYS—Onion and sour apple chopped and fried; curry powder added, and broth or water; split kidneys put in; simmered, thickened; served with rice. KIDNEY PATTIES—Patty cases filled with

## KIS

(1) the kidneys in cream, above; (2) kidneys, ham and mushrooms cut in dice, fried together; thick sauce added. ROGNONS DE MOUTON A L'EPICURIENNE—Mutton kidneys cut open, bread-crumbed and broiled; the hollows filled with tartar sauce, and devil sauce around. ROGNONS DE MOUTON A LA VENITIENNE—Kidneys in halves fried in butter with shallots; dressed on a border; brown sauce with anchovy butter. ROGNONS DE MOUTON AU VIN DE CHAMPAGNE—Thin slices of kidneys parboiled, simmered in butter; served in white sauce with champagne and mushrooms. PETITS PATES AUX ROGNONS—Kidney patties, as above previously described. ROGNON DE VEAU SAUTE—Calf's kidney minced, stirred up in a pan with butter; brown sauce and wine added. ROGNON DE VEAU EN CAISSE—Small round slices of veal kidney in brown sauce with shallots and mushrooms; baked in small paper cases, the tops sprinkled with bread-crumbs. ROGNON DE VEAU A LA JARDINIERE—Specialty of Paris restaurant. Kidneys in slices skewered edgewise, cooked in kidney fat with vegetables, covered with buttered paper; drained, taken off skewers, glazed, placed in dish; peas on one side, green beans on other, glazed spring carrots at one end, duchesse potatoes to finish. Tomato sauce separate.

KINGFISH—A southern sea fish of the Spanish mackerel variety. It is boiled and served with Hollandaise sauce, or baked with fine herbs, or split and broiled in the usual way for all fish, served with *maitre d'hotel* butter spread upon it and garnished with parsley and lemons. FILLETS OF KINGFISH A LA COLBERT—Boneless sides seasoned, dipped in flour, then in egg and bread-crumbs, fried; *maitre d'hotel* butter, parsley and lemons.

KING'S RINGS—King's rings is a French dish fit for a king. Make a little delicate mince-meat simply of veal or chicken, carefully flavored to taste, and enclose it in rings of carrots cut in slices. The success of this dainty depends entirely on the flavoring.

KIPPERED FISH—Smoked fish. KIPPERED SALMON—Smoked salmon. KIPPERED HERRINGS—Common smoked herrings. "And the process by which herrings are determined as 'bleaters' or 'kippers' were explained to him. The work was going on in full swing, the strapping Scotch lassies and women almost running about their work, with no head-dress but a shawl—brawny-looking Amazons."

KIRSCHWASSER (Ger.)—Liqueur made from cherry juice. The name signifies cherry-water. SORBET AU KIRSCH—Punch flavored with kirschwasser. The cherry-seed flavor of this spirit makes it very good for all sorts of cakes, ices and sweets.

KISELLE (Fr.)—Corn-starch jelly, made by thickening boiling raspberry syrup with starch enough to make it jelly when cold.

KISSES—Common popular name for meringues of cake icing baked on paper; also, certain candies.

## KIT

**KITCHEN OF THE PHARAOHS**—"Nothing is more curious and interesting in that remarkable discovery lately made by Mr. Flinders Petrie in the loneliest and dreariest corner of the north-eastern Delta, where he has actually unearthed 'Pharaoh's house in Tahpanhes,' of which we read in Jer. xliii, than the perfect condition in which the kitchen and servants' offices have been found. The kitchen, which was in use nearly three thousand years ago, is a large room with recesses in the thickness of the walls, which served for dressers. Here some fourteen large jars and two large flat dishes were found by Mr. Petrie standing in their places, unharmed amid the general destruction, as they may have stood when the fugitive daughters of Zedekiah, then a dethroned and mutilated captive in Babylon, were brought to Pharaoh's palace in Tahpanhes by Johanan, the son of Kareah, followed by 'all the captains of the forces' and 'the remnant of Judah.' A pair of stone corn-rubbers, a large iron knife, various weights, and three small flat iron-pokers—or possibly spits—were also found in the kitchen. The butler's pantry was, of course, the room to which wine jars were brought from the cellars to be opened. It contained no amphoræ, but hundreds of jar-lids and plaster amphoræ-stoppers, some stamped with the royal ovals of Psammetichus, and some with those of Necho, his successor. Here also was found a pot of resin. The empty amphoræ, with quantities of other pottery, mostly broken, were piled in a kind of rubbish depot close by. Some of these amphoræ have the lute-shaped hieroglyph signifying *nefer* (good) scrawled three times in ink upon the side, which, not to speak it profanely, may probably indicate some kind of 'XXX' for Pharaoh's consumption. Most curious of all, however, is the small apartment evidently sacred to the scullery maid. It contains a recess with a sink; a built bench to stand things upon; and recesses in the wall by way of shelves, in which to place what had been washed up. The sink is formed of a large jar with the bottom knocked out, and filled with broken potsherds placed on edge. The water ran through this and thence into more broken pots below, placed one in another, all bottomless, going down to the clean sand some four to five feet below. The potsherds in this sink were covered with organic matter and clogged with fish-bones. In some of the chambers of the palace there have been found large quantities of early Greek vases, ranging from 550 B. C. to 600 B. C. This discovery of the palace of Pharaoh in Tahpanhes is by far the most interesting yet made in connection with the Egypt Exploration Fund."

**KOHL-RABI**—The turnip-rooted cabbage, or above-ground turnip; a root very much like a cabbage stalk in taste. Is said to be best when cooked with the outside peel on and peeled after cooking. It is then cut in large dice and put in white sauce or brown, or chopped in cream, or served with small

## KOU

pieces of boiled bacon, or mashed or cooked in any way that other vegetables are.

**KOONTIE**—The "koontie," a plant which grows in Florida, has been called the "Indian bread root," and the meal or flour made from it is very much like the arrow-root of commerce. It makes a beautiful white flour, of which bread and puddings are made which are delicious and especially invaluable for invalids. The Indians and natives have used it for bread for many years, and people who have tried it think there is a fortune in store for anyone who will engage extensively in the manufacture of "koontie" flour.

**KOSHER** (Heb.)—Pure. See *Jewish cookery*.

**KOUMISS**—Fermented milk. This is a regular article of sale in the large cities. The taste is much like buttermilk. Some like it as a beverage, others drink it for their health. At the drug stores where sold it is in bottles kept on ice, and the purchaser is asked whether he wishes it fresh, medium, or old. The old bottled *koumiss* contains a small per cent. of alcohol, developed from the yeast-fermentation of the milk, it discharges the cork from the bottle with force like wine. The real original *koumiss* is made of mare's milk and is a Russian-Tartar drink, originated by the tribes on the steppes of Tartary. Koumiss made in this country is of cow's milk. There are certain differences which result in there being less alcohol in American than in Russian koumiss. *Government Report*: "Fermented mare's milk has long been a favorite beverage in the East, where it is known as 'koumiss.' Although the Tartars and other Asiatic tribes use mare's milk for the manufacture of koumiss, yet it is not the only kind that can be employed. Since the consumption of milk-wine has extended westward cow's milk is chiefly employed for making it both in Europe and America. Mare's milk is considered most suitable for fermentation because of the large percentage of milk-sugar which it contains. Dr. Stahlberg, who brought forty mares from the steppes of Russia to Vienna for the purpose of using their milk for koumiss, found its percentage of lactose to be 7.26. On the other hand, ordinary mares that were kept at work gave a milk containing only 5.95 per cent. sugar. The quantity of milk-sugar in a mare's milk is great, but there is a deficiency of fat and other solids. It appears to contain fully 89 per cent. water, while cow's milk does not have more than 87 per cent. The mares from which the milk was taken were on exhibition at the London International Exposition for 1884. These animals were obtained from the South-eastern Russia. The mares were from 5 to 6 years old, and were cared for and milked by natives of the country from which they were taken. When milked five times daily the best of these mares gave from four to five litres of milk. The process of manufacture is not uniform. In the East the mare's milk is placed in leathern vessels; to it is added a portion

## KRO

of a previous brewing, and also a little yeast. In thirty to forty-eight hours the process is complete. During this time the vessels are frequently shaken. Good cow's milk, however, is suitable for the manufacture of koumiss after most of the cream has been removed. Should it be desired to make a koumiss richer in alcohol, some milk-sugar could be added. In the samples analyzed by me the milk was treated with a lactic ferment and yeast. After twenty-four to forty-eight hours' fermentation the koumiss was bottled. The bottles were kept in a cool place, not above 50 degrees F., and in a horizontal position. When shipped to me they were packed in ice. After they were received in the laboratory they were kept on ice until analyzed. The samples analyzed were kindly furnished by Mr. ——— of Indianapolis. This koumiss makes a delightfully refreshing drink. When drawn from the bottle and poured a few times from glass to glass it becomes thick like whipped cream, and is then most palatable. It is much relished as a beverage, and is highly recommended by physicians in cases of imperfect nutrition. **AS MADE IN LONDON**—A small quantity of a preparation, usually consisting of yeast, honey, alcohol, and a little flour, is added to warm milk or milk and water. The whole is stirred, both to aerate it and to prevent it from turning acid; a faint odor announces the establishment of fermentation, and at the proper time it is poured into bottles, like those used for champagne, which are then corked and wired. **AMERICAN RECIPE**—Fill a quart champagne bottle up to the neck with pure milk; add two tablespoonfuls of white sugar, after dissolving the same in a little water over a hot fire; add also a quarter of a two-cent cake of compressed yeast. Then tie the cork on the bottle securely, and shake the mixture well; place it in a room of the temperature of 50 to 95 degrees F., for six hours, and finally in the ice box over night.

**KROMESKIES**—Russian croquettes. Croquette mixture of any material, meat, fish, chopped oysters, chicken or anything, rolled up into shape of bottle corks, then rolled up in the thinnest possible shavings of cold boiled bacon, dipped into batter, fried like fritters in hot lard. Served with fried parsley or caper or other sauce.

**KUCHEN** (Ger.)—Cake of any kind. **APFEL-KUCHEN**—Apple cake.

**KUMMEL**—The chief liqueur of Russia, made of cumin seed and caraway seed in sweetened spirit.

## L.

**LACTOMETER**—Glass instrument for ascertaining the quality of milk. (*See Milk.*)

**LADY-FINGERS**—The well known finger biscuits or Savoy biscuits made of sponge cake batter laid in finger lengths on paper.

**LAFAYETTE FISH**—A sea-chubb, so called from having appeared in great numbers at the time of Lafayette's visit to America; it was thought to

## LAK

be a new species and a name was sought for it. Cooked by flouring and frying.

**LAFAYETTE CAKE**—Jelly cake with many layers piled high, iced over and ornamented. Flat jelly cakes with colored icings are also sold by the same name.

**LAGER BEER**—The annual manufacture of beer in this country is about 19,000,000 barrels. Counting 1,000 glasses to a barrel, no extravagant estimate, we have about 380 glasses per annum to every inhabitant of the United States. In this country there are three varieties usually known by the common name of lager beer, though, strictly speaking, only one of them is entitled to the adjective "lager." The Winter, pot beer, schenk (or schank) beer, but sold as lager, is intended for immediate use, and is light, containing less than three per cent. of alcohol; the true lager, or stored beer, should contain at least three and a half per cent. of alcohol; while the bock beer, the strongest of all the German beers, and so named from causing its customers to prance and tumble about like a buck or goat, contains as much as five per cent. alcohol. The latter is generally sold for only a few weeks in the beginning of summer, and is in great demand by amateurs of the beverage. At the lager beer cellars a costly apparatus is employed to force air into the beer. It consists of an air pump which compresses air in a tank, a pipe connects the compressed air with the beer keg. In some places the kegs are packed in ice, in others where it is not drawn directly from the keg it is forced through a coil of pipe packed in ice and comes out ice cold. "If the tale of the German is true, who says:

'Gabrantius König von Brabant  
Der zuerst das Bier erfand.'

I bless the memory of the good King Gabrantius, and quaff my nut-brown ale and sparkling lager with the consolation of knowing that kings can do no more."

**LAITANCES** (Fr.)—Roes of fish. **LAITANCES DE CARPE**—Carp roe. **LAITANCES D'ALOSE**—Shad roe. **COQUILLES DE LAITANCES**—Scalloped roes in shells. **CASSEROLE DE LAITANCES**—Roes in the saucepan; stewed roes in sauce.

**LAIT** (Fr.)—Milk. **LAIT D'AMANDES**—Milk of almonds. **LAIT DE POULE**—A drink of milk and raw egg.

**LAITUE** (Fr.)—Lettuce.

**LAKE TROUT**—The Mackinaw trout; large fish of the trout family caught in the great American lakes; first quality, fine flavor; cream-colored or pink fleshed, inclined to softness, best when boiled. Large quantities are salted and sold by the barrel in brine. The methods and sauces suitable for salmon will be equally applicable to lake trout. **TRUITE DU LAC A LA MONTEBELLO**—Large trout, skinned on one side and that side larded with fat bacon, stuffed; cooked in the oven with paper over and wine, broth and onion, etc., in the pan. Fish



## LAMB

taken up, pan liquor thickened with curry powder, butter and flour. Mushrooms, fish quenelles.

**LAMB**—Lamb is the favorite meat of the Greeks and Turks. It is more exquisitely dressed in the Turkish kitchen than in that of any other country.

**ROAST LAMB**—In a dripping pan dashed with boiling water, cooked 15 minutes for each pound; basted often. Ten minutes before taken up it is dredged with flour and basted with butter. Fat poured off, gravy made in pan and currant jelly mixed with it.

**BREAST OF LAMB WITH PEAS**—Cut in square pieces, floured and half fried, stock or water added, simmered tender, peas in the remaining liquor served with it. **LAMB CUTLETS AUX PETITS POIS**—Cutlets breaded and fried; frills on the bones; border of mashed potatoes in dish hollowed in middle and filled with peas, mushroom sauce around, cutlets on the mushrooms around the central border. **LAMB CUTLETS A LA DEMI-DEUIL**—When lamb cutlets are

*saute*, it is usual to surround them with a border of truffles, which is called *demi-deuil*—a kind of half-mourning for the gentle creature. **LAMB CUTLETS AND STUFFED CUCUMBERS**—Ornamental dish; cucumbers hollowed and stuffed with bread forcemeat, stewed in milk, made cold, cut into rings, breaded, fried, cutlets with frills on bone arranged alternately in a crown, macedoine of vegetables in center.

**SAUTE D'AGNEAU AUX TOMATES**—Paris restaurant specialty. Boned shoulder of lamb cut into 1 inch squares, fried in 4 oz. butter with 3 onions and 2 cloves of garlic; 12 tomatoes cut in halves, half fried in butter then added to the stew and all cooked 15 minutes; croutons around. **LAMB CUTLETS AU PARMESAN**—Cutlets partly fried in butter to set them in shape, then dipped in white sauce made thick with grated cheese, breaded, egged, breaded again and fried. **LAMB CUTLETS WITH YOUNG CARROTS**—Breaded cutlets with very small carrots cooked whole and seasoned with butter, chopped parsley, pepper, salt, sugar, lemon juice. **LAMB CHOPS A LA PRINCESSE**—Broiled chops dipped in white mushroom sauce, made cold, egged and breaded and fried. Served with asparagus in white sauce. **LAMB CUTLETS A LA CHIATLELAINE**—Cutlets sauteed on one side, cooled, trimmed, the cooked side covered with purée of chicken and onion moistened with cream and egg. The uncooked side is next sauteed which sets the covering. Served with demi-glace and purée of green peas. **SELLES D'AGNEAU A LA TOULOUSAIN**

—Three saddles of lamb boned and served in turban form. The meat is cut in fillets which are larded, half with lean ham, half with truffles; marinated in oil and lemon juice, arranged in alternate form with forcemeat between, covered with buttered paper, baked, served with *financiere* garnish. **LAMB CUTLETS A LA BOULANGERE**—Cutlets dipped in oil and flour, and broiled; cream sauce. **COTELETTES D'AGNEAU AUX PETITS LEGUMES**—Breaded and fried; julienne vegetables in brown sauce in the dish. **COTELETTES D'AGNEAU A LA DUCHESSE**—Spread over with *Duxelles* sauce, made cold, breaded, fried;

## LAMB

served on a border or purée of green peas with mixed vegetables in white sauce in the center. **COTELETTES D'AGNEAU A LA POMPADOUR**—Cutlets half sauteed to set them in shape, coated with a mince of bacon, veal, truffles, herbs, seasonings, wrapped in buttered writing paper, cut to fit, cooked in the oven, but finished on the gridiron to make the broiler marks. Served in the papers with their own gravy still inclosed. **COTELETTES D'AGNEAU FARCIES AUX TRUFFES**—Cutlets larded, coated with purée of truffles in thick sauce, made cold, then breaded and fried; brown sauce. **COTELETTES D'AGNEAU EN BELLEVUE**—Cold dish; larded ornamentally with tongue, etc., braised, laid in a dish, melted aspic poured over, cut out when cold with the coating of jelly upon them. Served with mayonnaise-aspic. **EPIGRAMME OF LAMB**—See *epigramme*. **BLANQUETTE D'AGNEAU**—Small round slices of cooked lamb and tongue in white sauce, with parsley and button mushrooms; served in a casserole or border. **TENDRONS D'AGNEAU**—The breast cut in pieces,



LAMB CUTLETS.

Macedoine in center, silver skewer and truffle, on ornamental stand of nouilles paste.

**QUARTIER D'AGNEAU A LA BROCHE**—Fore-quarter roasted. **QUARTIER D'AGNEAU A LA HOTELIERE**—Roasted and served in a sauce of *maitre d'hotel* butter and cream. **COTES D'AGNEAU A LA CHANCELIERE**—Fore-quarter to be served whole. The shoulder is cut off, the meat is chopped into a kind of well seasoned sausage meat, put back on the ribs, breaded over, browned in the oven. **SELLE D'AGNEAU A LA BONNE FERMIERE**—Roast saddle of lamb with a border of breaded lamb's fries and mint sauce. **SELLE D'AGNEAU A L'ALLEMANDE**—Saddle boned, stuffed, braised, served with vegetable garnish. **SELLE D'AGNEAU A LA VILLEROI**—Boned, stuffed, braised, covered with thick Allemande sauce, grated cheese and bread-crumbs, browned. **GIGOT D'AGNEAU A LA PALESTINE**—Leg of lamb with purée of Jerusalem artichokes. **EPAULE D'AGNEAU A LA MONTMORENCY**—Shoulder boned, stuffed, larded, braised, served with Toulouse garnish of mushrooms, etc. **PATE CHAUD D'AGNEAU**

## LAM

—Lamb pie, hot. **MINCED LAMB**—Cooked lamb minced fine, seasoned highly, made hot in thick gravy, piled in middle of dish with poached eggs and fried croutons around. **LAMB CUTLETS WITH PUREE OF MINT**—Cutlets  $\frac{1}{2}$  inch thick breaded, fried, served with mint sauce. **ROAST LAMB A LA DUDLEY**—Leg of lamb with skin removed, surface larded with strips of sweetbread and kidney; covered with the caul fat of the lamb, roasted, mint sauce.

**LAMBS' FRY**—The "pluck;" heart, liver, lights, etc. Same as pigs' fry, sheeps' fry. (*See next item.*)

**LAMB FRIES**—Club dish. May be broiled, fricasseed, and stewed in wine sauce, but are generally fried. They are split or sliced, sprinkled with pepper, salt, lemon juice, dipped in flour, then in egg and bread-crumbs and fried. They are hard to fry dry and with the covering of crumbs unbroken, need plenty of room in plenty of fat that is very hot, otherwise they shrink away and are soaked with grease. Should be cooked only as wanted and served hot. May be served on a bed of mashed potatoes, or with peas.

**LAMBSQUARTER**—Popular name of a kind of wild salad greens. (*See Fett.cus.*)

**LAMPREY**—A kind of eel, thicker in proportion to its length, oily, not very abundant. Cooked in the same ways as eels, also potted by baking in a jar with butter and spices; eaten cold. **LAMPROIE A L'ITALIENNE**—Fillets of lamprey stewed in wine with oil, onions, herbs and lemon juice. **LAMPROIE AU SUPREME**—Lamprey cut up, sautéed, served in sauce of red wine with truffles.

**LANDRAIL**—A kind of snipe.

**LANGOUSTE (Fr.)**—The crawfish or sea crayfish; a small lobster.

**LANGUE (Fr.)**—Tongue. **LANGUE DE BŒUF**—Beef tongue.

**LAPEREAU (Fr.)**—Young rabbit.

**LAPIN (Fr.)**—Rabbit.

**LARDOONS (Fr.)**—Shreds of bacon or pork.

**LARD (Fr.)**—Bacon.

**LARDING MEAT**—The inserting of strips of fat bacon or *lardoons*.

**LARDING NEEDLES**—Long needles having the butt end like a tube split open to admit the strips of bacon for larding meat.

**LARD**—A great deal of watered lard is now sold branded "pure," and consumers should be on their guard against this imposition. A very simple test of purity is to drop a small piece of lard into a hot fire. If pure it burns smoothly, like oil; if watered it crackles and splutters. Watered lard is unnaturally white, and is colder to the tongue than pure lard. Buyers of refined lard should ask for a guarantee that it is absolutely free from water. Lard is very much sophisticated in other ways. The dealers offer three or more grades, not pretending that

## LAV

they are pure. Manufacturers testified before a committee of congress that about one third of the lard sold is composed of cotton-seed oil, combined with beef stearine and chemicals. The refined oil is as good as lard for some purposes, such as frying, but ought to be at a lower price than lard. Stewards who wish to have lard used for making pastry, should buy the firmest and best, as soft lard is useless for that purpose.

**LARKS AND LARK-PIES**—The common lark, which is called in Paris *mauviette*, is generally looked upon as a wholesome, delicate, and light game. It is dressed in various ways; and the *gourmets* appreciate the value of the excellent lark-pies, which have established the reputation of the town of Pithiviers in France. **HOW TO JUDGE LARKS**—The physician of Queen Anne, Dr. Lister, like his royal mistress a great gastronomer, appraised the goodness of larks by their weight. He laid down the rule, which has ever since been held sound, that twelve larks should weigh thirteen ounces, and that if below that weight they are not good. **LARKS A LA FRANCAISE**—Pick and clean (leaving the livers in) six larks, cut off the heads, wing-bones, and feet just below the second joint; tie a piece of fat bacon over each, put them in a stewpan with a gill of chicken consommé, in which throw a dessert spoonful of chopped parsley, three chopped chives, one teaspoonful of white pounded sugar; let them stew for fifteen minutes, add salt to taste, and serve with the sauce in which they have been stewed. **MAUVIETTES GRILLEES**—Larks split open and broiled, on toast or fried bread. **MAUVIETTES EN SALMIS**—Salmis of larks. **MAUVIETTES A LA CHIPOLATA**—Cooked in the oven and served with a chipolata garnish of chestnuts, small sausages, etc. **MAUVIETTES EN CAISSE**—The larks are boned, the bones and trimmings boiled with vegetables and bacon to make sauce; livers and chicken livers cut in dice, fried with onions, rubbed through a sieve; liver paste placed in the oiled paper cases, lark on top, slice of bacon over it, baked 15 minutes. **TURBAN DE MAUVIETTES A LA PARISIENNE**—Boned, stuffed with game forcemeat, braised, dished crown-shape, quenelles in center and game sauce. **MAUVIETTES EN COTELETTES**—Boned larks, spread with forcemeat, breaded, browned in oven, served with brown sauce. **CROUSTADE DE MAUVIETTES**—Larks boned, stuffed and baked in a croustade of fried bread. **LARK PIE**—Larks trimmed, stuffed with bread stuffing, seasoned; slices of bacon and beefsteak in a dish, larks on top, broth and seasonings, top crust of paste; baked an hour or more. (*See Mauviette.*)

**LASAGNES**—A kind of macaroni or Italian paste in the form of yellow ribbon.

**LAVER**—An edible seaweed. In Ireland it is called "sloke," is cooked like spinach and is also fried in bacon fat after boiling; it is best to have a porcelain saucepan to cook it in as it acts upon metals, but is wholesome nevertheless.

## LAW

**LAWN TENNIS CAKE**—A Richfield Springs confectioner and restaurant-keeper is making and selling by the pound a cake which he calls lawn-tennis cake. It is a sort of Genoa cake iced over the surface and covered thickly with chopped pistachios.

**LEEK**—A species of onion; the green leaves are flat like ribbons; not tubular like an onion, but the taste resembles onion. It is used in most soups when it can be obtained. **LEEK AS A VEGETABLE**—Leeks are very good served on toast as asparagus. Trim the leeks and cut away the green till there is little left but the white part; clean thoroughly, and boil till tender. Pour good melted butter over them and serve very hot. **LEEK SOUP A L'ECOSSAISE**—"The leek was a favorite ingredient in the 'cockie leekie,' of which James I. is reported to have been so fond, that he retained his preference for it, notwithstanding all the dainties of London cookery." **LEEK SOUP A LA PICARDE**—Leeks cut in shreds, half fried in butter, beef broth and sliced potatoes added, boiled; small toasts. **PUREE OF LEEKS**—A soup made same way as with onions. **POIREAUX AU JUS**—Leeks cooked like asparagus and served with meat gravy.

**LEGUMES (Fr.)**—Vegetables.

**LEIPZIG PANCAKES**—Sweet pancakes in pairs with jam between; they are raised with yeast, rolled out thin like small crackers, and fried in a little lard.

**LEMON**—Nearly everything in the sweet line is flavored with lemon sometimes, and lemon cream, lemon pudding, lemon cake, etc., have no definite form otherwise. **LEMON SOUP**—Chicken broth thickened like custard with yolks and cream, and lemon juice added. **LEMON BUTTER**—Yolks, flour, and butter stirred into boiling lemon syrup. Used to fill tarts, spread jelly cakes, etc. **LEMON HONEY**—Sugar dissolved in lemon juice with the grated rind and butter; boiled, and thickened with yolks; a kind of jam with neither water in it nor flour. **LEMON PIE**—(1) Butter, sugar, and eggs creamed together as for cake, grated rind and juice added, and bread-crumbs to make it like cake dough; baked in open pies. (2) Mixture of 1 lb. sugar, 1½ pts. water, 4 lemons, 2 oz. butter, 5 oz. flour, 6 or 8 eggs; baked in open pies, meringued over. **LEMON CREAM PIE**—Frangipane or pastry cream with grated rind and juice in it; baked as a custard pie; whipped cream spread over it when cold. **LEMON SPONGE**—Lemon jelly whipped to froth while cooling; served with custard. (See *Jellies*.) **LEMON TRIFLE**—Whipped cream flavored with grated rind and juice, sugar, sherry, and nutmeg; served heaped in small glasses. **LEMON SAUCE FOR FISH AND FOWLS**—Chopped lemon, without seeds, stewed in little water, mixed with white sauce or cream sauce. **SWEET PICKLED LEMONS**—To eat with game. Thin-skinned fruit to be chosen, the rind carved ornamentally with point of a penknife; lemons boiled until tender in sweetened water, then put in jar, strong syrup poured over boiling, reboiled and poured to them 3 times.

## LET

**LEMON DUMPLINGS**—Small round dumplings steamed, or boiled in a cloth; made of ½ lb. bread-crumbs, ½ lb. chopped suet, 1 lemon rind and juice, ¼ lb. sugar, spoonful of milk, 2 eggs; boiled ½ hour; wine sauce. **LEMON PEEL**—Can be made into flavoring by paring thin and putting into a bottle of whisky; the liquor becomes extract of lemon. **KEEPING LEMONS**—Lemons may be kept perfectly fresh for six months, or longer, if kept immersed in a vessel in enough buttermilk to cover them. The buttermilk should be changed at least twice a month, and the lemons should be wiped perfectly dry with a cloth when required for use. **LEMON MINCEMEAT**—See *Mincemeat*. **LEMON SYRUP**—Surplus lemons are used to make syrup by paring the rind thinly, and squeezing the juice, and boiling in sugar syrup; straining and bottling for use when fresh lemons cannot be obtained. **LEMON MARMALADE**—The lemons boiled in 3 waters, taken up when tender, sliced, seeds removed; fruit weighed, 2 lbs. sugar and 1 pt. water to each pound of fruit; boiled together ½ hour. **LEMON ROLY-POLY**—Sheet of short paste spread with lemon marmalade or lemon butter, rolled up, steamed. **LEMON SHERBET**—See *Sherbet*.

**LENNOX SLICES**—A new cake strongly flavored with chartreuse is popular just now in New York at tea and luncheon parties. It is introduced under the name of "Lennox slices."

**LENTILS**—Kind of pea used for soup; of a brown color, flattened shape. Lentils are said to contain twice the nourishment of flesh meat; the small Egyptians are the best. **BOILED LENTILS**—Soaked overnight and boiled same as beans or peas, seasoned with bacon or butter. **PUREE OF LENTILS**—Boiled or stewed lentils rubbed through a sieve, seasoned, served as a vegetable. **LENTIL SOUP**—Lentils boiled with stock, water, leeks, parsley, celery, salt pork, etc.; passed through sieve, same as pea soup; croutons of bread. **POTAGE A LA CHANTILLY**—Purée of lentils soup with cream.

**LETTUCE**—"Lettuce is not much cooked in this country and when cooked it is not much better than a cabbage; but when raw, and eaten in salad, it has a peculiarly pleasant taste; and has a sedative action upon the nervous system, which makes one return to it eagerly, as one returns to tobacco and to opium. The chemists obtain from the lettuce an inspissated juice—called sometimes lactucarium, sometimes lettuce-opium—which is said to allay pain, to slacken the pulse, to reduce animal heat, and to conduce to sleep." **WIPED, NOT WASHED**—"Lettuces ought never to be wetted; they lose their crispness, and are *pro tanto* destroyed. If you can get nothing but wet lettuces, you had certainly better dry them; but if you wish for a good salad, cut your lettuce fresh from the garden, take off the outside leaves, cut or rather break it into a salad bowl, and then mix." **A MEDICAL REMARK**—"Some are now strongly insisting that lettuces should be used more generally as food, and suggesting that they

## LEV

ought to be boiled, after which treatment they are said to be as palatable as spinach. If this be the fact, it is worth knowing, as spinach is necessarily excluded from the diet of the oxaluric patient, and it is precisely in this class of cases the soothing properties of the lettuce, if it have any, would be valuable." **BOILED LETTUCE**—Boiled in very little water and turned frequently; when quite tender drained, pressed, chopped fine, put in a stewpan with little cream, butter, pepper, and salt. **LETTUCE SOUPS**—Consomme a la Cobert, Consomme a la Kursal, Consomme a la Chiffonade, Potage aux Herbes Printanieres, Potage a la Bonne Femme. **CONSOMME AUX LAITUES**—Halves of lettuces tied and stewed, served with consomme separately. **LETTUCE SOUP A L'AMPHITRYON**—Stewed lettuce chopped and seasoned with cheese, filled into croustades made of rolls hollowed out, sprinkled with cheese, crumbs and butter, browned, served with consomme separately, and grated cheese with it. **STUFFED LETTUCE**—Parboiled, drained, split open, forcemeat or sausage meat inserted, fat pork outside, simmered an hour. **LETTUCE SALADS**—(See *Salads*.)

**LEVRAUT** (Fr.)—Hare. **LIEVRE** is the same.

**LEVERET**—Young hare. (See *Hare*.)

**LIAISON** (Fr.)—Anything that is put into soup or sauce to thicken it, especially eggs, stirred in to make it creamy like a custard.

**LICORICE** or **LIQUORICE**—An American root used extensively for making the extract which is sold extensively in the form of stick liquorice, as a remedy for coughs. **LICORICE COUGH LOZENGES**—Specialty; made of dissolved stick licorice and gum arabic in water to make 2 qts. thick mucilage; 28 lbs. powdered sugar, 2 oz. ipecacuanha, 1 drachm acetate of morphia, 1 oz. oil of aniseed, 1 oz. powdered tartaric acid; enough of the licorice mucilage to make paste of it, rolled, stamped out.

**LIEVRE** (Fr.)—Hare; same as *levraut*.

**LIMA BEAN**—The butter bean; thrives best in the long summers of the southern states; one of the most delicate of vegetables in the green state, and nearly as good after drying. It is boiled like green peas and seasoned and sauced the same ways. **LIMA BEANS SAUTES IN BUTTER**—After boiling tender put in a pan with butter, parsley, salt, pepper, simmered a short time, served hot. **LIMA BEANS SOUP**—Purée of lima beans in seasoned broth with butter and sippets of fried bread.

**LIMANDE** (Fr.)—Dab; a small flat-fish.

**LIMBURGER CHEESE**—A very high-flavored and odorous cheese, now extensively manufactured in this country to meet a very large demand. It is a soft whitish cheese of about the consistency of new soap, and is in bars wrapped in tinfoil.

**LIME**—A small kind of lemon, plentiful in the markets, used in many of the same ways as lemons; served with oysters, used in making bar drinks. It is pale-colored, thin-skinned, more acid and juicy

## LIV

than the lemon. **LIMES FOR GARNISHING**—"As a piquant addition to a veal cutlet, or fried sole, the juice of the lime is to our mind preferable to that of the lemon. In most tropical countries where limes grow, a regular supply is laid in weekly of some six or eight dozen, at a cost of a few cents, and the juice is eaten with almost everything that appears at table, except 'Irish stew.'" **PICKLED LIMES**—Limes with slight cuts in the rind are rubbed with salt, allowed to remain 5 days to soften. Vinegar boiled with 4 oz. each mustard seed and ginger to each quart and 1 oz. whole pepper; limes and salt in a jar, boiling vinegar poured upon them. **PRESERVED LIMES**—Limes boiled in 3 waters, sliced, stewed in sugar. (See *lemon*.) **LIMES WITH RICE**—Limes preserved in syrup served on rice boiled in milk and sweetened, after the manner of peaches with rice, the lime syrup for sauce.

**LING**—A fish that resembles cod, plentiful on the coast of Scotland. It is sometimes imported as a novelty, used in all the ways of cod to cook or dry, and oil is obtained from the livers the same as from cod livers.

**LION**—Lion's flesh is almost identical with veal in color, taste and texture—so the hunters say.

**LIPTAU CHEESE**—The famous goat's-milk cheese of Liptau, in Bohemia, similar to the Italian Moring cheese. It comes wrapped in tinfoil, packed in boxes.

**LIQUEURS**—Various flavored spirits, such as chartreuse, absinthe, vermouth, etc.

**LIQUEURS**—Name of a certain class of candies flavored with liqueurs; boubons. The best have a liquid inside while the outside is crystallized.

**LIQUEUR CANDY WITH EGGS**—Suitable for hotel dessert. It is ribbons of flavored egg-yolk cooked by running through a funnel into boiling syrup, then draining and rolling in granulated sugar. Takes 7 lbs. sugar boiled to "the blow" or below candy point, 12 yolks beaten up with kirschwasser run in like a rope from a funnel; is yellow and crystallized. Needs a name.

**LITRE**—The French quart; is about 2½ American pints.

**LIVER**—Calf's liver is much sought after for restaurant trade, and the butchers seldom have any for casual buyers; it is much better than any other, though beef liver is not bad. Pig's liver is next best; sheep's liver is the worst, being hard. Calf's liver and bacon is a popular breakfast dish. **LIVER AND BACON EN BROCHETTE**—(1) Cut bacon in thin slices, then in squares, scald the liver to set it in shape, then cut thin squares to match the bacon. String liver and bacon alternately on a skewer and broil on all four sides. If silver skewers serve without removing them, if iron skewers slip the meat off on to a slice of toast. (2)—Prepared as above, egged, breaded, fried in hot lard, served with sauce. **FRIED LIVER**—Slices seasoned, dipped in

## LIZ

flour and fried in shallow pan with little bacon fat. **LIVER AND ONIONS**—Fried liver covered with onions which have been fried separately. **BROILED LIVER**—Floured, broiled, basted with butter, served with *maitre d'hotel* butter. **LIVER SAUTE**—Small pieces of liver and bacon simmered in the bacon fat, with little onion, seasoned, water added and gravy made in the pan. **ROAST LIVER**—Large piece larded through and through with finger strips of fat bacon, which are rolled before insertion in minced garlic, herbs and mixed spice, roasted with same seasonings in the pan, and pepper and salt; gravy in the pan with lemon juice added. **LIVER A LA MODE**—Liver larded through and through with strips of carrot, turnip and bacon, herbs and seasonings, baked slowly in deep pan with buttered paper over; gravy with wine in the pan, served with vegetables. **FOIE DE VEAU A L'ITALIENNE**—Calf's liver cooked with oil, wine, bacon, mushrooms, herbs, lemon juice; sauce made in the pan. **PAIN DE FOIE DE VEAU**—Liver paste; pounded and steamed in a mould with eggs, chopped ham, bay leaf, wine seasonings, served hot with brown sauce, or cold, or in sandwiches. (*See fromage d'Italie.*) **CHICKEN LIVER PATTIES**—Chicken livers, calf's liver, and calf's kidney cut very small, simmered in butter with seasonings, flour and gravy added and little sherry; dished in patty cases. **DEVILLED LIVER**—Parboiled turkey liver mashed with butter, mustard, salt, cayenne, mushroom catsup. Stirred over fire till very hot, served on toast. (*See foie gras.*) **LIVERWURST**—Liver sausage made of liver and bacon fat with coriander seed, cloves or garlic. **LIVER SOUP**—See *gondingo*. **LIVER KLÖSE**—Liver, bacon, bread-crumbs, butter, eggs, parsley, salt, pepper; made into paste, formed in balls, boiled in water. (*See German cookery.*)

**LIZARD**—"I do confess, though, that on one of the last occasions of my dining in Honduras I did not feel that all was well, when at the end of the meal I found that I had stuffed myself with baked lizard. Of course, there is nothing wrong with the lizard, except our petty prejudices. It tasted splendidly; but when at last I saw the big, scaly leg and the claw of the lizard, I don't think I liked it." (*See Guana.*)

**LOBSTER**—On the French coast a lobster is boiled in half milk and half water. The "Cardinal of the Sea" is also cooked in a *court-bouillon*, made of a handful of salt in the water, a pat of butter, a bunch of parsley, a clove of garlic, and a claret-glass of Chablis or Marsala, the wine being added after the lobster has boiled for a quarter of an hour. **BROILING LOBSTERS ALIVE**—"Broiled live lobsters are the latest in the fish restaurants, and jolly nice they are, too! They split Mr. Lobster down from head to tail, and pop him on the grill—flat side down. He is served scalding hot, and you eat him with lemon and cayenne." **ALLEGED CULINARY CRUELTY**—The sign "broiled live lobsters" has appeared at a number of the city restaurants. If the lobsters were

## LOB

put on the gridiron whole, the practice would call for suppression by law. Such is not the practice. To broil a lobster in its shell would have no effect different from boiling or steaming; the broil is attained by the exposure of the inside flesh to the fire. The splitting down the full length of the lobster kills it before it reaches the fire. The seat of life is a spot in the center of the head where it joins the body, and when the cook's knife passes through it, life ceases, though the mechanical contractions of the members may continue for awhile. A lobster can be killed instantly by thrusting a skewer into the part, either from the back of the head or through the mouth. The catfish is one of the slowest animals to die, and hours after it has been skinned and cut up in pieces, if the head be opened carefully, the seat of life can be found like a heart, about the size of a lima bean, still beating with pulsations plain to see; but if this spot be pierced even when the fish is first caught and most alive, it dies immediately. **LOBSTER A L'AMERICAINE**—A freshly killed lobster is cut up into 8 or 10 pieces, the claws making 4 more, and the head is set apart. Some oil is poured in a shallow saucepan, and into it is put mushrooms, onions, shallots, garlic, thyme, bay-leaves, parsley, salt, white pepper, cayenne, fried all together, without the lobster, till light brown; the oil then drained off, 3 tomatoes and a bottle of Chablis added; boiled 5 minutes, and the pieces of lobster, shell and all, thrown in; cooked ½ hour, taken up, and the sauce thickened with the substance found in the head, and 4 yolks; carefully mixed in without boiling; strained over the lobster. Same method as with crabs for gumbo, and the southern or creole fish *court-bouillon*. **HOMARD AU COURT-BOUILLON**—Lobster boiled in ordinary *court-bouillon* (which is seasoned broth with little wine), and served with lobster sauce. **LOBSTER AU KARI**—Curried lobster, served with rice. **COTELETTES DE HOMARD**—Lobster cutlets. (*See Cutlets.*) **MIROTON DE HOMARD A LA CARDINAL**—Slices of lobster, half dipped in white sauce, half in cardinal sauce; served cold on a salad with mayonnaise. **COQUILLE DE HOMARD**—Lobster in the shell; scalloped lobster made by cutting the meat of cooked lobster small, putting it in a yellow sauce containing onions, wine, yolks, etc., filling plated scallop shells or the back shell of the lobsters with it; crumbs and butter on top; baked. **CROQUETTES DE HOMARD**—Same as cutlets except the shape. **RISSOLES DE HOMARD**—Croquette-preparation rolled in paste and fried. **PETITS VOL-AU-VENTS DE HOMARD**—Lobster patties. **BOUCHEES DE HOMARD A LA BECHAMEL**—Smaller patties filled with chopped lobster in cream sauce. **MAYONNAISE DE HOMARD**—Lobster-meat with lettuce and mayonnaise; decorated. **LOBSTER A LA NANTAISE**—Cold; the lobster boiled in ordinary *court-bouillon*; the creamy part from the head with the coral, and some yolks and mustard stirred with oil, to make mayonnaise; the lobster-meat sliced in a bowl, and sauce poured over. **STUFFED LOBSTER**,

## LOB

**NARRAGANSETT STYLE**—Like devilled crabs; lobster-croquette preparation filled in the pieces of lobster shell; crumbed, buttered, baked. **TURBAN OF LOBSTER A LA MAZARIN**—Sliced lobster with forcemeat and sauce in a border mould; steamed till set firm, turned out, and center filled with oysters, mushrooms, fish quenelles, and sauce; served hot. **BALLOTINES OF LOBSTER**—Lobster meat cut small in creamy sauce; used to stuff tomatoes, which are then placed with the aperture downwards in little patty pans and steamed; served hot or cold, with fish-quenelles and sauce, or in aspic. **LOBSTER CHEESE**—Like head cheese. Lobster chopped or sliced, mayonnaise jelly made and stirred into it; seasonings; set in a mould. (*See Mayonnaise.*) **LOBSTER A L'IRLANDAISE**—Meat of a boiled lobster in a stewpan with mustard, vinegar, cayenne, and flour-and-butter for thickening; covered, simmered 5 minutes, glass of sherry added; served hot with lemon. **LOBSTER PUDDING**—English; lobster-croquette mixture containing eggs, boiled in a mould for an hour; served with lobster sauce. **LOBSTER EN BROCHETTE**—Pieces of lobster alternately with slices of bacon strung on a skewer; buttered; broiled. **LOBSTER CREAM IN ASPIC**—Lobster meat in white sauce set with gelatine. **MAZARINS OF LOBSTER**—The preceding and similar jellied forms set in small moulds, called mazarin moulds. **LOBSTER SOUP**—(1) One quart stock to 1 can lobster, 1 cup milk, 2 yolks, parsley, pepper, salt, flour-and-butter worked together enough to thicken it. (2) Fish broth, 2 qts.; 1 can lobster, milk thickened with starch added, and butter and seasonings. **LOBSTER SOUP A L'INDIENNE**—Fried vegetables and aromatics, broth, wine, and lobsters boiled together; curry powder, pounded lobster shells, butter and flour boiled in the liquor; lobster meat in the tureen, and the curry soup strained over it; rice separate. **BISQUE OF LOBSTER**—Made of rice and lobster. Butter, onions, ham, salt pork, and parsley fried together; cut-up lobsters in shell thrown in; wine, broth, seasonings; boiled an hour. Lobster meat and shells pounded in a mortar, passed through seive; rice the same; broth passed through seive, lobster liquor added, and sherry; not boiled; served with fried sippets of bread. **LOBSTER SAUCE**—(1) White butter-sauce with lobster coral to color it, and lobster cut in small dice. (2) Butter sauce, salt, white pepper, nutmeg, cayenne, lemon juice, anchovy essence, lobster butter, strained; lobster meat cut small added; it ought to be pink in color. **LOBSTER BUTTER**—Coral and eggs of cooked lobsters pounded in a mortar, mixed with equal quantity of butter; rubbed through a seive. **LOBSTER SALAD**—See *Salads*.

**LONGE DE PORC (Fr.)**—Loin of Pork.

**LORDKOLL CAKE OR ALMOND PUDDING**—Paris specialty. "Call it any name you like. It is called Lordkoll Cake here. This is how it is prepared: Prepare 1 lb. sweet almond powder, to which add ½ oz. bitter almonds, all very dry. Add 1 lb. powdered sugar. Take 16 eggs, of which

## LUC

separate the yolks from the whites. Add yolks to mixture, working them in carefully. Beat up whites with vanilla and add. Take Charlotte moulds, which butter and flour. Fill your mould with the mixture, and bake in a slow oven. Cakes to be served hot and usually covered with an English or vanilla sauce."

**LOVE IN DISGUISE**—Is a calf's heart stuffed, then surrounded with forcemeat, next rolled in powdered vermicelli, lastly deposited in a baking dish with little butter and cooked in the oven. Serve it in the dish with its own gravy.

**LOSS OF WEIGHT**—Chickens lose one third their weight in boiling and one third more in picking from the bones and mincing. 4½ lbs. raw chicken yields only 1½ lb. clear meat for salad. "The result of a set of experiments which were actually made in a public establishment. They were not undertaken from mere curiosity, but to serve a purpose of practical utility: 28 pieces of beef weighing 280 lbs. lost in boiling 73 lbs. 14 oz. Hence the loss of beef in boiling was 26½ lbs. in 100 lbs.; 19 pieces of beef weighing 190 lbs. lost in roasting 61 lbs. 2 oz., or 32 lbs. in 100 lbs.; 9 pieces of beef weighing 90 lbs. lost in baking 27 lbs., or 30 lbs. in 100 lbs.; 27 legs of mutton weighing 260 lbs. lost in boiling and by having the shank-bone taken off 62 lbs. 4 oz. (the shanks weighed 4 oz. each.) The loss in boiling was 55 lbs. 8 oz.; the legs of mutton lost 21½ lbs. in 100 lbs.; 35 shoulders of mutton weighing 350 lbs. lost in roasting 109 lbs. 10 oz.; loss of weight in roasting shoulders of mutton is about 31½ lbs. in 100 lbs.; 16 loins of mutton weighing 141 lbs. lost in roasting 49 lbs. 14 oz.; loins of mutton lose by roasting about 35½ lbs. 100 lbs.; 10 necks of mutton weighing 100 lbs. lost in roasting 32 lbs. 6 oz. From the foregoing statement two practical inferences may be drawn: (1)—In respect of economy that it is more profitable to boil meat than to roast it. (2)—Whether we roast or boil meat it loses by being cooked from one-fifth to one-third of its whole weight."

**LOTUS SEEDS**—Lotus seeds form one of the most common dishes known to the Barri of Central Africa. The pods when gathered are bored and strung on reeds and hung in the sun for drying, after which they get to the table.

**LOTTES (Fr.)**—Eel-pouts.

**LOZENGES**—Candies made without boiling, of powdered sugar, sometimes starch and adulterations and gum mucilage, cut out and dried. **LEMON ACID LOZENGES**—Made of 8 oz. icing sugar, ¼ oz. powdered tartaric acid, 10 drops oil of lemon; mixed with mucilage of gum arabic into a paste, rolled out and cut into lozenges. (*See Licorice.*)

**LUCULLUS**—Often named in relation to gastronomy. A Roman general. Lucullus' suppers cost in our money ten thousand dollars each. He was perhaps the most refined entertainer among the famous few whose names are immortal because of

## LYO

their extravagance. **BOUDINS DE VOLAILLE A LA LUCULLUS**—Quenelles of chicken forcemeat with purée of truffles in the center of each. They are formed with two spoons, poached, glazed and colored in the oven, served in a shape of fried bread with allemande sauce. **FILLETTS DE BECASSES A LA LUCULLUS**—Breasts of woodcocks coated with forcemeat and served on a border of toast with a thick purée of woodcocks in the center and game sauce around. Any dainty and expensive or tedious ornamented dish of birds or small game is designated a la Lucullus by any ambitious *chef*, particularly dishes of ortolans or larks with truffles, whether hot or cold.

**LYONNAISE GARNISH**—For braised meats; consists of stuffed onions, cooked chestnuts, and sliced sausages in the braise liquor and espagnole.

**LYONNAISE SAUCE**—Brown onion sauce with a small proportion of tomato sauce mixed in.

**LIVOURNAISE SAUCE**—Cold, for boiled fish. It is mayonnaise with pounded anchovies and parsley worked in.

## M.

**MACARONI**—There is American macaroni that usually comes loose in the large boxes, and some of it is as good as the imported; it should be tried, however, a small quantity first, for poor macaroni dissolves in the water it is boiled in, and is of no more use than so much flour paste. The difficulty in making seems to be the choice of flour; macaroni needs a particular kind. It is cheap food, comparatively, as it is dry and in condensed form and without waste. **MACARONI AU BEURRE**—Macaroni with butter; the most ordinary way of serving it in Italy. It is not broken much, but thrown at once in boiling salted water and cooked from 15 to 20 minutes, drain, put a piece of butter in the centre and sprinkle cheese over the top; place on the top shelf of a hot oven till thoroughly heated and brown on top. **MACARONI AND CHEESE**—Boiled macaroni with butter, salt and grated cheese mixed together hot, and served plain. **MACARONI A LA CARDINAL**—Macaroni and lobster, made by putting a layer of boiled macaroni in a dish, a layer of lobster butter, then a layer of white sauce, then grated cheese, and repeating till the dish is full, with pieces of lobster and truffles on top; made hot without browning. **MACARONI A LA DOMINICAINE**—Boiled macaroni with purée of mushrooms and anchovies. **MACARONI AND KIDNEYS**—Sliced kidneys fried, tomato sauce added, layer of macaroni, layer of kidneys and sauce, macaroni on top; chopped hard-boiled eggs and grated cheese to finish; baked enough to melt the cheese on top. **ENGLISH MUSTARD AND MACARONI**—“The dressing and the eating of macaroni are very imperfectly understood in England. It is usually served at the end of the dinner; it should be one of the earliest dishes partaken of; few cooks know how to boil it, and send it to table either of the consistency of pap, or underdone and leathery. Finally,

## MAC

at some English tables this delicious, wholesome article of food has inflicted upon it the dire outrage of being ate with mustard. Mustard with macaroni! As well might one eat strawberry-cream with chili vinegar.” **BUTTERED MACARONI**—Put a piece of fresh butter the size of an egg into a well-warmed deep dish; lay on it about half a pound of boiled macaroni, well drained; turn it over, as a salad is ‘worked,’ with two forks adding during the process plenty of fresh-grated Parmesan cheese. **BAKED MACARONI**—A pound of macaroni boiled in salted water; drained; pepper, salt, 1 pt. cream sauce, 6 oz. butter, 6 oz. cheese; mixed; in baking dish with cream sauce spread on top, cheese, crumbs, bits butter; baked brown. **FONDUE A LA NAPOLITAINE**—Short macaroni boiled; fondue of cheese, eggs, and butter stirred together till hot, not boiled; poured over the macaroni in a dish. **MACARONI AU GRATIN**—Same as baked macaroni. **MACARONI A LA CREME**—Boiled macaroni in cream-sauce containing grated cheese. **MACARONI A L’ITALIENNE**—With brown gravy, butter and cheese. **MACARONI WITH TOMATOES**—Macaroni mixed with cheese and butter, tomato sauce poured over; simmered in the oven covered with buttered paper; served with fried croutons. **MACARONI WITH OYSTERS**—Oysters cut in pieces after scalding, cream sauce made with the thickened oyster-liquor added, and the oysters in layers with boiled macaroni; bread-crumbs and butter on top. **MACARONI AND FISH**—Same as with oysters, using flakes of boiled cod, salmon or snapper. **MACARONI A LA GENOISE**—Macaroni served with tomato sauce without baking; grated Parmesan cheese sprinkled on top. **CROQUETTES OF MACARONI AU FROMAGE**—Bunches of sticks of macaroni parboiled, taken hot and laid straight with plentiful grated cheese among the sticks, rolled up in buttered cloth and cooked in fish kettle; when cold, the bunch of sticks of macaroni adhering together is cut off in lengths of croquettes, breaded and fried; tomato sauce. **TIMBALES OF MACARONI**—Like a macaroni pie. (1) Macaroni in long sticks cooked in a fish-kettle; when cool, coiled like straw in a buttered mould or deep pan to make a close lining; filled inside with chicken forcemeat, steamed, turned out; served with sauce. (2) Mould lined with short lengths of macaroni built up with ends outwards like honey comb; filled with macaroni, cheese, egg and butter mixture; steamed; turned out whole; sauce. (3) Mould lined with pie-paste previously decorated with shapes of yellow nouilles paste stuck on with butter, filled with macaroni-and-cheese mixture; baked, and turned out whole. **TIMBALE DE MACARONI A LA FLORENTINE**—Sweetened macaroni or macaroni-pudding baked in a crust of paste to turn out whole; sweet sauce with raisins. **MACARONI SOUPS**—Numerous. (*See Soups.*)

**MACAROONS**—Small drop-cakes made principally of sugar and almonds; but there are various kinds. (1) One pound flour,  $\frac{1}{4}$  lb. butter, 1 lb. pounded sugar, 3 eggs, 20 drops of any essence,  $\frac{1}{2}$

## MAC

teaspoonful ammonia; mix well in the order named; drop pieces, the size of a walnut, on to buttered sheets, and bake a pale color in a cool oven. The ammonia is best dissolved in 2 teaspoonfuls of milk, and almond is the most appropriate flavoring. (2) One-half pound crushed and sifted almonds,  $\frac{3}{4}$  lb. sugar, 2 oz. rice-flour or starch, 5 whites; stirred up into a paste, dropped on paper, baked in cool oven. (*See Almonds, Coconut.*) MACARON TARTS—Patty pans lined with thin sweet tart-paste, little jam in them, above almond-macaroon mixture on top; baked in slack oven. MACARON CUSTARDS—Macaroons dipped in brandy, placed in buttered cups, strong custard to fill up, steamed or slack-baked, and turned out whole to serve; pink sauce with wine. MACARON ICE CREAM—Almond macaroons crumbled in ice cream make a fine bisque of almonds. MACARON CAKE—Sheet of genoise cake baked; almond-macaroon mixture laid across with a tube; slack baked, jelly or jam dropped in the lattice-work spaces; to serve whole or cut in squares.

MACE—The inner coat of the nutmeg, between the nutmeg and the outside shell, is called mace. It is a good flavoring for meats and cream soups, as well as puddings and sweets, if used sparingly. For the meat kitchen it is generally needed in blades or the unground state; the ground spice goes into mincemeat, puddings, and cakes.

MACEDOINE—A mixture of several kinds of vegetables or fruits. MACEDOINE VEGETABLES—Are put up in cans like any other vegetables; can be obtained at the fancy grocery stores. The vegetables are cut with *jardiniere* machines all to one size and quite small. There are carrots, turnips, peas, string beans and other kinds in the mixture, the object being to secure a variety of colors. This mixture in hot gravy makes the macedoine garnish to go with cutlets or other meats; or, with oil, vinegar and seasonings, makes the macedoine salad. MACEDOINE OF FRUIT—Several kinds of fruit in a compote, or charlotte, or meringue. MACEDOINE DE FRUITS EN GELEE—A mould of alternate layers of different fruits filled up with jelly.

MACKEREL—Choice fish plentiful on both sides the Atlantic. Says GRIMOD DE LA REYNIERE: The mackerel has this in common with good women—he is loved by all the world, he is welcomed by rich and poor with the same eagerness. He is most commonly eaten *a la maitre d'hotel*, but he may be prepared in a hundred ways, and he is as exquisite plain as in the most elaborate dressing. THE PERFECT WAY—“There is but one perfect way of cooking mackerel—split him in the back, broil him, and serve him with *maitre d'hotel* butter. Still better, take his fillets and serve in the same way.” MACKEREL IN SEASON—Mackerel which are taken in May and June are superior in flavor to those caught either earlier in the spring, or in the autumn. They are best *a la maitre d'hotel*. To enjoy the flavor of these fish, they should not be washed, but wiped

## MAD

clean and dry with a cloth. BROILED MACKEREL—The fish laid open by splitting down the back, the back bone taken out. Juice of  $\frac{1}{2}$  lemon squeezed over each fish, after drying it, also salt and pepper, broiled over clear coals, skin side down at first, butter over. STEWED MACKEREL—Clean and cut a fresh mackerel into four pieces, and take out the bone. Have ready a pint of melted butter, seasoned with a little salt, mace, and cayenne. Throw in the thin rind of  $\frac{1}{2}$  lemon, and the juice also. Stew the fish in the sauce twenty minutes, and just before serving add a dessertspoonful of anchovy sauce and a little mustard. MACKEREL A LA FLAMANDE—Clean the fish and stuff with butter mixed with chopped shallots, chives, lemon-juice, salt and pepper; wrap in sheets of buttered paper, tie up the ends with string, and broil over a slow fire for twenty-five minutes; remove the covers and serve. BAKED MACKEREL WITH VINEGAR—Cut off the heads and tails, open and clean the fish, and lay them in a deep pan with a few bay leaves, whole pepper, half a teaspoonful of cloves, and a whole teaspoonful of allspice, pour over them equal quantities of vinegar and water, bake for an hour and a half in a slow oven, and serve when cold. Herrings are also nice prepared in this way. ROLLED MACKEREL—The fish laid open, back bone removed, and head. Rolled up, tail outwards, cooked as baked mackerel with vinegar, with plate or top to hold them in shape. Served cold. MAQUEREAUX A L'EAU DE SEL—Mackerel plain boiled in salted water. MAQUEREAUX GRILLES AU BEURRE NOIR—Mackerel broiled, served with black butter sauce. MAQUEREAUX AUX GROSEILLES VERTES—Mackerel stuffed with green gooseberries, pieces of herring, etc., boiled and served with green gooseberry sauce. FILETS DE MAQUEREAUX A LA VENETIENNE—Boneless sides of mackerel served in brown sauce with tarragon, chervil, truffles, and port wine. BOILED MACKEREL—Cut in halves boiled in water containing onion, parsley, white wine, salt, pepper for 15 minutes, served with ravigote sauce, or with caper sauce, parsley sauce or other, which gives the name. MACKEREL BALLS—Of salt mackerel made same as codfish balls. SALT MACKEREL—There are 3 or more grades, the largest are the best; can be freshened most completely by soaking in milk. Are cut up and boiled a very few minutes, served with plain butter or with mustard sauce. Broiled they are buttered and garnished with lemon and parsley.

MADEIRA BUNS—1 lb. flour, 10 oz. butter, 7 oz. sugar, the grated rind of a lemon,  $\frac{1}{4}$  oz. ground ginger, 3 eggs, tablespoonful of sherry. Cream and mix as for cakes, put one tablespoonful in small moulds or patty pans, and bake in a moderate oven; strip of citron on top of each.

MADEIRA CAKE—Plain pound cake by another name, made of 12 oz. sugar, 10 oz. butter, 10 eggs, 1 lb. flour, 1 teaspoon baking powder, ground mace or other flavor, baked in shallow cake moulds.



## MAD

**MADEIRA SAUCE**—Wine sauce of two kinds, either savory or sweet, both having Madeira wine in them. (1)-Broth thickened with butter and flour, a pickled lemon cut up in it, little more butter beaten in, glass of wine, nutmeg; for fish, or boiled meat or fowl. (2)-Pudding sauce with Madeira. **MADEIRA PUDDING**—A jam pudding steamed, made in a deep round pan; a sheet of short paste is laid in the bottom, a layer of jam on that, then another sheet of paste, then jam of a different color, and so on to fill the pan like a jelly cake of paste and jam. Steamed 2 or 3 hours. Cream for sauce.

**MADELEINES**—(1) Small cakes of the genoise cake sort, baked in patty pans or madeleine moulds; like madeira buns, but richer, made of  $\frac{1}{2}$  lb. each of butter, sugar, flour and eggs and wineglassful of brandy. (2)—The same with currants, mixed peel, and sultanas added.

**MADONNA PUDDING**—Steamed pudding of 12 oz. bread-crumbs, 8 oz. sugar, 8 oz. finely chopped suet, grated rind of 1 lemon, 2 eggs, 2 tablespoons brandy. To be beaten industriously together with a wooden spoon; steamed 3 or 4 hours.

**MAGENTAS**—Small sort of sponge cakes baked in narrow tins; made of 1 lb. sugar, 12 eggs,  $\frac{3}{4}$  lb. flour, almond and orange flavoring, 6 oz. butter; whipped up separately as for sponge cake, butter softened and beaten in, whites last of all, chopped almonds on top.

**MAIDS OF HONOR**—A puff-paste tartlet with a cheese-cake filling is popular in England under that name, and two or three special makers of it have realized a competency. At one place this dainty has been produced for 200 years, the secret of the mixture bequeathed from father to son. "Mr. J. T. B., confectioner, of Richmond, sends us a box of the delicious little cakes associated for nearly two centuries with the famed Thames-side resort. They are admirable eating, but at this time of year are all the better for being warmed. As to the origin of their curious name, Mr. B. informs us two explanations are current: one, that the maids of honor who, in the old court days of Richmond, used to frequent the shop where the cakes were originally made, suggested the name: the other, that the recipe emanated from a maid of honor."

**MAITRE D'HOTEL** (Fr.)—Steward or head-waiter; the head man of a restaurant next to the proprietor.

**MAITRE D'HOTEL SAUCE OR BUTTER**—(1)—The almost universal sauce with broiled fish and other broiled meats. It is nothing but butter softened and stirred up with chopped parsley and lemon juice in no particular measure; looks pale green; used cold or at ordinary room temperature to spread on hot fish. (2)—**HOT MAITRE D'HOTEL SAUCE**—The cold sauce thrown into a saucepan with little water is slightly thickened with flour, to form a semi-transparent parsley sauce for new potatoes *a la maitre d'hotel* and for boiled fish.

## MAL

**MAITRE D'HOTEL** (*a la*)—Boiled fish sprinkled with chopped parsley, or capers or other green and the above, hot sauce poured over it; and broiled fish or meat with cold *maitre d'hotel* butter are so denominated. Plain boiled potatoes quartered belong to the style with boiled fish, and lemons with broiled.

**MALDIVE FISH**—Mummalon fish or "Bombay duck," an East Indian fish; canned, sold at the fancy grocery stores.

**MALLARD DUCK**—The largest American wild duck, the original stock of the tame duck of the same name and markings. This duck is extremely plentiful in the lake region in the fall season; carloads are brought to Chicago where the surplus is kept in a frozen state for sale in the spring when other game is out of season. The mallard is among water fowl what the prairie hen is among the varieties of the grouse family, the fleshiest, heaviest, tenderest, and in a general way the most valuable. Stewards sending for game by the barrel do well to order mallards. **MALLARD DUCK A L'AMERICAINE**—Ducks roasted rare in about 25 or 30 minutes, carved, pieces between two dishes kept hot; bones boiled with aromatics, brown gravy added to the liquor, currant jelly and port wine. (*See Ducks.*)

**MALT**—The baker who makes his own yeast uses malt perhaps twice a month to make his stock yeast, the process for which is much the same as brewing beer, though the product is very much condensed. Malt can generally be purchased at the nearest brewery. **WHAT MALT IS**—Malt is barley that has been sprouted and started to growing by being sprinkled with water in a warm place; in this condition it turns partly to sugar, the starch in the seed changing to sweetness. At the right stage, before the sprout turns green, the barley is dried on a hot metal floor with a constant stirring. It is then malt. Other grains are treated in the same way for purposes of distillation; thus there is malted wheat and malted rye. **MALT BREAD**—Specialty or novelty. Bread made with a proportion of the flour from malted wheat. **MALT BROWN BREAD**—English patent. "The digestive quality of malted barley are fully recognized, and the idea of blending it with granular wheat-flour in the bakery has proved a happy one, for the resulting bread, while appetizing and well flavored, is soft and moist even after several days' keeping." **MALT WINE**—"There is a great craze at present for malt wine. Some years ago it was very fashionable when the malt coffees and malt breads first began to tickle the palates of the epicures. It is beginning to look up again, as some of the great lights of the medical profession have been recommending it to august patients." Made of 14 lbs. loaf sugar, 9 qts. boiling water poured upon it, and 6 gls. sweet wort from the brewers; remains in a mash-tub to ferment for 2 days; then put into a keg with another pound sugar and  $1\frac{1}{2}$  lbs. raisins; to be filled up daily as it ferments

## MAN

and runs over, 1 oz. gelatine dissolved and whipped to froth added; bunged tight; bottled 6 months after. Instead of brewers' sweet wort, 8 gls. water, hot, on a bushel of malt and  $\frac{1}{4}$  lb. hops, boiled and strained.

**MANDARIN ORANGE**—A small variety of orange; very sweet; flattened somewhat in shape. Gives the name "mandarine" to jellies, and ornamental pieces formed of candied oranges.

**MANGO**—Fruit of the West Indies, Florida, and Mexico. "One of the most delicious products of the tropics is the mango, the eating of which, however, is apt at first to embarrass and perplex a stranger to no small degree. In shape the mango resembles a pear with the stem at the wrong end, flattened, however, like a bean, and with the small end turned over to one side, something like the figures common on cashmere shawls. One large variety is entirely yellow, and a smaller kind is yellow with rich red cheeks, offering tempting hues for a still-life painter. Inside is a very large seed, which forms a considerable impediment to the enjoyment of the inexperienced, for the pulp is joined to this in a stringy way, and it is difficult to handle the slippery thing. A thoroughly ripe mango has a kind of combination of muskmelon and baked custard aspect and texture to its deep yellow pulp, and its rich flavor is indescribable, except that, when eaten for the first time, it seems to have a slight trace of turpentine, which resemblance, however, disappears on acquaintance. The large yellow variety seemed to me to have a very slight and delicate flavor of peanut candy. The person who eats mango for the first time generally covers himself with confusion and his face with mango pulp and juice, which is very sticky and yellow, so that he looks as if somebody had been feeding him with soft-boiled eggs in the dark. It will not do to eat a mango as one would an ordinary fruit, the correct way being to use a mango-fork, which has but one tine, and therefore is really not a fork at all, but a spit. With this the fruit is impaled at one end and the point thrust firmly in the seed, which may thus be stripped of its last pulp without soiling the fingers."

**MANGO PICKLES**—Not the mango of the tropics, but stuffed young melons or cucumbers. The cucumbers or young muskmelons have a piece cut out to admit a spoon and the inside scooped out; they are filled with a variety of other small kinds of pickling vegetables, with horse-radish, mustard seed, etc., the cut piece replaced, tied or sewed, then put through the usual pickling process of pouring boiling vinegar on them 4 successive days.

**MANGOSTEEN**—"Travelers in Java have filled pages and columns with rhapsodies over the mangosteen, and all unite in extolling it as the supreme delight of the tropics. The mangosteen appears to one as a hard round fruit the size of a peach. Its hard outer shell or rind is of the same color and thickness as a green walnut, but in this brown husk

## MAR

lie six or eight segments of creamy white pulp. The little segments are easily separated, and transferred to the mouth melt away, the pulp being as soft and fine as custard. The mangosteen's delicate pulp tastes, as all its eulogists say, like strawberries, peaches, bananas, and oranges all at once; a slight tartness is veiled in these delicious flavors, and it is never cloyingly sweet. Taken just as it comes from the ice box the mangosteen is an epicure's dream realized, and the more's the pity that it only grows in far-away places and deadly climates, and does not bear transportation."—"It is an old story," says an author, "that the traditional resident of Calcutta thought it worth a man's while to make the voyage from England to Calcutta by the Cape of Good Hope and back only to eat one mango at the proper season. But the majority will probably concur with me that the fruit of the East—the mangoes, leeches, guavas, custard-apples, tipparees, and pomegranates—can bear no comparison with the fruit of the West.

**MANISTEE FISH**—"One of the leading restaurants at Chicago had a novelty on its bill of fare last week, it being the first time that Manistee beef was ever placed before the Chicago public. Though called beef, it is in fact the flesh of a fish extremely rare in these parts. The Manistee is a fish the size of a sturgeon, found only in the Manistee river, in Florida. It is sightless, but acute of hearing. It is speared by the negroes, by whom it is highly prized as food, and occasionally is to be found in the markets of New Orleans and Mobile, but is seldom found in this locality. The flesh is coarse and much resembles beef, though retaining the fishy flavor. Scientists have never been able to discover the origin of the fish, but inclined to the belief that it rises from some subterranean stream or lake and has increased and multiplied in the Manistee river, but, owing to its lack of sight, it has not been able to make its way into other bodies of water."

**MANSFIELD PUDDING**—Rich bread pudding baked; made of 4 oz. crumbs of French rolls wet with a cup of boiling milk, 2 eggs, 3 oz. suet mixed with 1 tablespoon flour, 4 spoons currants, 2 spoons sugar, 1 spoon cream, 1 spoon brandy, nutmeg; all beaten together for 5 minutes.

**MAQUEREAU (Fr.)**—Mackerel.

**MARASCHINO**—A cordial made from the seed of a particular sort of Italian cherry, with syrup and spirits of wine. It is one of the most admired flavorings for jellies, creams, charlotte russe, ices, and sweet sauces. It is, however, difficult to get the genuine, and the flavor of the imitations, though pleasant, is not so remarkable. It comes in quart flasks in wicker coverings, price about \$2 per flask. **BRITISH MARASCHINO**—Is made from 2 lbs. of lump sugar made into clear syrup with 1 pt. of water, a half-ounce bottle of almond essence, 1 bottle of cherry syrup prepared without acid; one tablespoonful of elder flower water, color up to the

## MAR

proper maraschino color if too faint, bottle and seal with red wax. This is easily and quickly made, and is sold under the name of British maraschino. SOUFFLE GLACE AU MARASQUIN—An iced soufflé with maraschino. GELEE AU MARASQUIN—Maraschino jelly.

MARBLE CAKE—Cake having marble streaks of another color of cake all through it, as white cake with veins of chocolate interspersed, or pound cake with pink wine cake.

MARBLE CREAM—Any of the gelatine creams broken apart and moulded solid again by pouring in warm melted cream of another color to make veins and streaks.

MARBLE GENOISE—A sheet of genoise cake spread with white water icing and streaked with colored icing while still wet.

MARCASSIN—“*Marcassin* is, in French sportsman's phraseology, a young wild boar. Its saddle is served roasted and carefully larded. Wild boar is just at present being greatly eaten in Paris, and is seen at all the better-class *magasins de comestibles*. At most it is sold ready-larded, at prices varying from 1 franc 60 centimes to 2 francs 40 centimes the pound.”

MARINADE—A bath of oil and vinegar or lemon juice, together with some aromatics, such as bay-leaves, thyme, onion, or according to the kind of meat to be marinated or pickled, and salt and pepper. The use of it is to steep meat or fish an hour or more before cooking to give them flavor and succulency. A dish of pieces of cooked brains, chickens or other cold meat steeped in this and afterwards in batter and fried, is called a marinade of that particular kind of meat.

MARLBOROUGH CAKES—Dry kind of sponge cake with caraway seeds; baked in long tins; sometimes sliced and dried in the oven for wine rusks. Made of 1 lb. sugar, 8 eggs beaten  $\frac{3}{4}$  hour, 1 lb. flour, 2 oz. caraway seeds. Also makes good lady-fingers.

MARMALADE—Word generally used in this country instead of jam. All kinds of fruit are boiled with sugar to the condition of jam or marmalade.

MARRONS (Fr.)—Chestnuts.

MARRONS GLACES—Candied chestnuts. (*See Crystallized Fruits.*) “One set of workers skin the chestnut, carefully separating it from the inner husk. They then pass through a number of other hands in the preserving process, and when complete they are turned over to yet another set of women to be put in neat boxes, or tied up in dainty glazed paper-bags.”

MARROW—Only obtained in quantity large enough to cook from the leg-bones of beef, especially the bone in the round. MARROW TOAST—Marrow cut thin, seasoned, laid close together upon toast, baked on top-shelf of oven; served hot. MARROW AUX FINES HERBES—Marrow scalded a few minutes in hot water, taken up and cooled, broken up

## MAS

and mixed with chopped mushrooms, parsley, onion; bread-crumbs in the bottom of buttered paper cases, marrow mixture to fill up, crumbs on top; baked 15 minutes; served on a napkin. MARROW PATTIES—Chopped marrow seasoned, cream, beaten egg; patty pans lined with puff paste; marrow filling; baked. MARROW QUENELLES—Half pound each marrow and bread-crumbs, 1 small tablespoon flour, 5 yolks, 1 egg, salt, pepper; work up to smooth paste, shape with two teaspoons, poach in boiling salt water. For garnishing, for soups, or served with sauce in a vegetable border. MARROW DUMPLINGS—Marrow from two beef bones chopped and melted, 2 eggs, salt, pepper, little nutmeg, crushed soda-crackers enough to make paste of it; boiled in small balls; to serve with meat or soup. MARROW SAUCE FOR STEAKS—Brown sauce made with chopped shallots, butter, white wine, espagnole, salt, pepper, parsley; beef-marrow in slices dipped in boiling water in a strainer for a minute, spread on the steaks; the sauce poured over and around. MOELLE DE BŒUF A LA ORLY—Beef marrow cut in long strips, dipped in batter and fried; tomato sauce. BOUCHEES A LA MOELLE—Small patties (*vol-au-vents*) filled with marrow chopped and simmered in a savory sauce of cream, shallot, chives, etc. PETITES CROUSTADES A LA MOELLE—The same as for *bouchees*; filled into little cases of fried bread; crumbs on top; browned. MARROW PUDDING—A sweet pudding steamed; made same as plain plum pudding, using melted marrow instead of suet or butter.

MARROW FRANGIPANE—Not made of marrow; only a name of almond pastry custard baked in center of a rice-paste-lined mould, sugared over the outside when done. A timbale of almond frangipane.

MARSHMALLOW—An edible plant; the roots are sliced, boiled and candied.

MARSHMALLOW CANDY—A name and imitation; made like gum drops, of 2 lbs. each gum arabic, fine sugar, water and glucose; the gum pulverized and dissolved in the water, glucose and sugar added, and boiled on a very slow fire; 3 whites to every pound beaten light and mixed in, and the whole beaten for  $\frac{1}{2}$  hour; forced through a tube into starch moulds, cut from the nozzle of the forcer with a knife.

MARZIPANS—Massepains.

MASSEPAINS—Almond paste cakes made of 12 oz. sweet almonds,  $1\frac{1}{2}$  lbs. powdered sugar, 4 whites. Almonds blanched, dried, pounded in a mortar with the white of eggs, sugar pounded into them, makes a paste which is forced through a lady-finger tube in a cord on powdered sugar, formed in rings and curves on pans; baked in a nearly cold oven. GERMAN MASSEPAINS OR MARCHPANES—One pound sweet almonds, 1 oz. bitter almonds, 1 lb. sugar, little rose-water; almonds pounded with rose-water, stirred with sugar in saucepan over the fire till a firm

## MAT

paste; when cool, rolled out in powdered sugar, cut in cakes, slightly baked.

**MATELOTE**—A fish-stew, consisting of a principal fish in large pieces, with oysters, mussels, button mushrooms, button onions, etc., and wine; to serve as a garnish. **MATELOTE SAUCE**—Brown; button onions glazed by frying in butter and sugar, flour added, and broth, herbs, seasonings, wine; herbs taken out, and extract of meat, essence of anchovy, coloring, mushrooms and oysters added. **MATELOTE NORMANDE**—Cream-colored; white sauce made of fish-broth and oyster-liquor thickened with yolks; lemon juice, butter, mushrooms, oysters, scallops, mussels, shrimps, cray-fish, little white wine. Serves as sauce and garnish to fish *en Matelote Normande*.

**MAUVIETTE** (Fr.)—Lark. Same as *alouette*. Different names equivalent to meadow-lark, skylark. (*See Alouette, Lark.*)

**MAYONNAISE**—Salad sauce; also cold sauce for fish. Made by putting into a bowl two or more raw yolks, little dry mustard, and stirring in drop by drop olive-oil, then some salt, then lemon juice or vinegar, also by drops alternately with the oil, continuing to thicken it by adding oil and thinning with vinegar and lemon juice until sufficient; must be twice as much oil used as vinegar. Two points to observe are to begin stirring the yolks with only a few drops of oil at the start; and, to add the salt after one-third the oil is in. A teaspoon powdered sugar and pinch cayenne to finish; 2 yolks will take up a cupful of oil. The sauce should be thick enough to spread over a dome of salad without running off. It becomes firmer by standing on ice a while.

**MAYONNAISE ASPIC**—Good, firm aspic-jelly barely melted stirred into an equal quantity of mayonnaise. It makes a glossy yellow mayonnaise-jelly for ornamental cold-meat dishes and salads.

**MAYONNAISES**—Term equivalent to salads. All dishes dressed with mayonnaise. A mayonnaise of lobster, of salmon, of chicken, of shrimps. Some salads have no such sauce or dressing, therefore the term is distinctive.

**MAZARINS**—Moulds of fish, fillets of chicken or anything similar, set with aspic jelly or aspic mayonnaise, and turned out when cold.

**MAZARIN CAKE**—A raised loaf of butter cake, not sweet, baked in a mould lined with almonds, cut in halves, and rum pudding sauce poured over it.

**MEAD**—Honey wine. "In the time of King Arthur and his Knights of the Round Table, the drink that was prepared for royal use was 'mead.' Mead kept its place at the tables of the rich and the great for a considerable time, and yet for centuries it seems to have fallen quite out of account. It is as little thought of now as *nepenthe*, the drink of the gods on Mount Olympus; and yet mead, we believe, can be made a very pleasant drink. A continental paper gives a recipe for its preparation. Honey is the

## MEL

sweetening constituent used. Forty to forty-five litres of water are put into a cauldron, with 10 litres honey; boil the mixture for 1½ hours, during which time skim off the scum. The liquid is then put into a cask to ferment for 3 weeks."—"The natives of Madagascar make a honey wine which is composed of three parts water to one part honey. They boil the water and honey together, and skim after the mixture is reduced to three-fourths. It is then put in pots of black earth to ferment. It has a pleasant tartish taste, but is very luscious." **ENGLISH MEAD**—Ten pounds honey, 6 gls. water, few mixed spices; boiled an hour; when cool, some yeast spread on toast put in. When fermentation ceases, the keg bunged up, kept in a cellar; bottled after 6 months.

**MECCA LOAVES**—Boston cream-puffs.

**MEDAILLONS** (Fr.)—Medallions. Small round shapes of potted meat, or jellied meat, like pats of butter; decorated. **MEDAILLONS DE FOIE GRAS**—Biscuit-shapes of *pate de foie gras* variously ornamented.

**MELEE CREAM**—For cakes and pastries; made of 1 lb. sugar, 1 doz. eggs whipped together ¼ hour over hot water or slow fire, and ¼ hour more on ice; dissolved gelatine, 1 oz. in ½ cup water, added while mixture is still warm. Spirits, flavoring essences or chopped figs as preferred. It makes a creamy sponge to fill a border-cake with. (*See Gateaux.*)

**MELON**—"Although in Europe the melon is generally eaten with salt and pepper after the soup, in this country on account of its fragrance and sweetness it is preferred between the cheese and dessert." It is served on a folded napkin with broken ice, the seeds having been removed previously. **COMPOTE OF MELON**—Cantaloupe or muskmelon slightly green sliced, pared, boiled in syrup made of 1 lb. sugar to ½ pt. water, and flavored with wine or lemon; served as compote of fruit with rice or *croutes*. **MELON PRESERVE**—(1) Slices of melon dropped into hot syrup and allowed to remain till next day; the syrup poured off, boiled, poured boiling hot to the melon-slices; repeat for 3 days. (2) Melon-slices steeped in cold water, vinegar and salt 24 hours; drained, put in cold syrup, gradually heated to boiling; taken up, syrup boiled and poured over 3 successive days. **MELON MANGOES**—Small, late melons, green, inside scooped out, put in brine 24 hours, filled up with small onions, beans, cauliflower, etc., and mustard-seed and horseradish; boiling vinegar with spices poured over 5 successive days. **MELON SALAD**—It makes one of the best fruit salads. Peel cut into small blocks; dress it with 1 tablespoonful of oil, in which you have mixed a small saltspoonful of salt; toss the melon gently in it, then use 1 or 2 more spoonfuls of oil, according to the quantity of fruit you have, and vinegar in proportion of ⅓ the oil; pepper to taste. **MELON-WATER ICE**—Ripe melon pounded through a seive, sugar, water, glucose, lemon juice; frozen. **PRESERVED WATER-MELON RIND**—The rind soaked in brine, then in cold water,

## MEL

then boiled in strong syrup, with ginger to flavor, makes one of the best of preserves; and if taken from the syrup and dried to the condition of *glace* fruits, is a most useful ingredient in ornamental pastry and confectionery work. **KEEPING MELONS**—Watermelons are now kept in a frozen state by cold storage.

**MELON MOULDS**—Tin moulds of graded sizes in the form of a half muskmelon. Can be found at most large tin and furnishing shops. They are used to steam puddings in, to press salads in to be turned out and spread over afterwards with mayonnaise, to set ornamental jellies and cream in, and to freeze *mousses* and other ices.

**MENEHOULD, SAINTE**—Name of a town. "Among French towns, Sainte-Menehould, Montbéliard, and Saverne, all possess a special celebrity for the manufacture of comestibles, in which the flesh of swine composes the principal ingredient. A special production of Sainte-Menehould is the pig's foot truffled."

**MERINGUE**—Name of the white mixture of sugar and white of egg, which in the soft form is spread over lemon pies and the like, and baked; in a firmer condition is the icing with which cakes are iced and ornamented. **SOFT MERINGUE**—For the tops of puddings, cup custards, etc.; made of 1 oz. sugar or little more to each white; white of eggs whipped up separately, sugar stirred in; very slack baked to fawn color. **ICING MERINGUE**—From 3 to 6 whites to each pound of sugar; mixed by barely wetting the sugar with 3 or 4 whites and beating with a paddle for 15 or 20 minutes; more whites can be worked in, according to the purpose intended. **FRUIT MERINGUES**—Sheet of cake spread with ripe raw fruit, covered with soft meringue, granulated sugar sifted on top; baked in very slack oven. **FLORENTINE MERINGUE**—Sheet of tart paste spread with marmalade, covered with soft meringue; baked. **MERINGUES A LA CREME**—Stiff meringue having 5 or 6 whites worked into the pound of sugar and little acid (*see Icing*) dropped on paper on boards, to prevent the bottoms from baking; slack baked, either put by twos together with their own softness inside, or insides scooped out and filled with whipped cream. **BORDER MERINGUES**—Stiff meringue laid with a sack and tube forcer in circles size of a saucer on paper, sugar sifted over; baked very light-colored and dry; removed from paper by wetting, rings piled on each other 3 or 4 high, ornamented with icing, center filled with whipped cream, *melée* cream, or bavarian with strawberries. **MERINGUE PANACHEE**—Meringue shells filled with ice cream, made same as meringue à la crème above; dried after emptying; served singly like shells filled with different colors of ice cream. **MERINGUE A LA PARISIENNE**—The border meringues above, piped with currant jelly.

**MERLUCHE (Fr.)**—Haddock.

**METZELSUP**—"Every well-regulated Pennsylvania-Dutch farmer kills at least two fat pigs every fall. The butchering is a grand affair, and all the

## MEX

neighbors join in and help. When the hogs are killed, dressed and cut up, certain portions are set apart for those who helped in the butchering, and for gifts to poor widows in the neighborhood. This is distributed with a liberal hand, and is called the metzelsup. The farmer who forgets the metzelsup is looked upon as one for whom perdition surely yawns." **METZEL SOUP DINNER**—"Mr. Thomas Brown, of the Enterprise Hotel, Stapleton, Staten Island, has given a 'metzel soup' dinner this as in previous years. He had a large and happy company present to enjoy his hospitality."

**MEXICAN COOKERY**—Remarks of friendly critics at the Capital. "A fair sample of the dinner bill of fare served for a dollar has been presented. Here is one for half a dollar, just as taken from the table of the Gillow Restaurant:

—*Sopas.*—

Consome.

Sopa de pescado.

Macarroni.

—*Pescados.*—

Huachinango.

Con alcaparras.

Huevos al gusto.

Beefsteaks.

Costillas de ternera.

Id. de carnero.

Id. milanesas.

Puchero.

Polla à la Toulousa.

Hijaditos de carnero à la lionesa.

Conejo con ungos.

Fricando à la macedonia.

Alcachopas à la diabla.

Guisado à la napolitana.

Roast beef.

Manitas en especia.

Pierna al horno.

Frijoles.

Ejotes.

Fruta. Dulce. Cafe. Te.

Platillos sueltos, uno y medio real.

Comida Cuatro Reales.

The explanation at the bottom of the bill is that a single dish, if the customer does not want the whole dinner, will be given for a real and a medio, 18 cents; or everything on the bill will be served for 4 reals, half a dollar. *Sopa* is the soup, of which three kinds are offered. *Pescados* is the fish, of course. *Huevos* the reader already recognizes as eggs. After beefsteaks come the chops, veal, pork, or mutton. *Puchero* is 'boiled,' and *pollo* is enough like poultry to give a clue to what it really is—the chicken. Then follow five different kinds of stewed meats, and after these the roasts; and not a few of those dining will go leisurely through the whole bill, occupying from one to three hours in the agreeable occupation of getting their money's worth. *Frijoles* and *ejotes* are beans and more beans, or baked beans and string beans. For *fruta* the waiter brings a plate of bananas, limes, and melons. *Dulce* is the pudding or sweets, and *cafe* is poured out in the cup before the guest—black coffee until he says 'stop,' and hot milk added until the cup is full. And yet Americans go home and say they cannot get 'a square meal' in Mexico. Descending the scale, there are the 3 reals.

## MEX

the 2 reals and the 1 real restaurants. For 12½ cents a wholesome meal may be had in Mexico—not elaborate, but satisfying to a hungry man. And still cheaper are the coffee and lunch stands, where, for a medio (which is a half real, 6 cts.) bread, meat, and coffee in generous quantities may be had. A quartilla (the fourth of a real, 3 cts.) buys a cup of coffee and a large roll at any one of the hundreds of little coffee houses scattered through the districts where the poorer people live. If there is any criticism to be passed upon the food of the country, it is in the over-abundance of meat dishes. Even the entrées are freshly cooked. Mexico is a semi-tropical clime, and fruits abound. Nevertheless it is quite the proper thing to sit down and go through the bill of fare—soup, eggs, a beefsteak or a mutton chop, chicken, the roast beef, and so on, finishing with the vegetables, one after the other, for, as already said, the table etiquette of the country prescribes one dish at a time.”

FRUIT FOR BREAKFAST—“It is a custom to precede coffee with an indulgence in fruit, which is delicious and cheap in this country and is regarded as particularly healthful at this time of day, and the great basketful set before one is tempting enough in richness, variety of colors and shapes.”

GRASSHOPPERS AND SHRIMPS—“In the markets of Mexico both these lively little creatures are to be found in the same condition as whitebait when it appeals to the palate of the *gourmet*, viz., fried whole, and they are eaten in the same way.” Mexico is now a great center for the manufacture of crystallized fruits. Apples, pears, crab apples, nuts, quinces, peaches, figs, oranges, lemons, limes, guavas, cactus leaves, and other varieties of tropical fruits are put up in forms as pleasing to the eye as they are exquisite in taste. A delicious confection is also made from sweet potatoes; another is dried bananas. They are all equal, if they do not excel, the best French preserves and sweets. They are absolutely unadulterated and are very cheap.

AN UNFRIENDLY CRITIC IN THE COUNTRY—“The reception was held in a large arbor, erected for the purpose, of wild cane-stalks thatched with straw. As usual, the men retained their hats and smoked incessantly between and during every course. Tortillas were continually sent in, hot from the griddle—made by women secreted in a hut somewhere in the rear—and piled in a steaming heap in front of the *alcadi*, who distributed them around with an easy and graceful scuffle, something as an expert player deals his cards. Now and then fresh water was passed in mugs, it being the elegant fashion for each guest to fill his mouth, draw it noisily to and fro between his teeth, then eject it upon the floor. The *menu*, as nearly as it can be rendered in English, was as follows:

Cigarettes.

Caldo (broth) with garlic, chilli and cigarettes.

Sopa—stewed in grease and garnished with chilli.

Cigarettes.

Pucharo—stuff of every description, fish, flesh, and fowl, seeds, pods, green fruits, roots and vegetables, all boiled together, served on a huge platter, with chilli sauce.

## MIL

Cigarettes.

Chicken stewed with grease and chilli.

Cigarettes.

Kid's head baked with garlic.

Cigarettes.

Red beans baked in oil.

Cigarettes.

Sweetmeats and coffee, with cigarettes.

Tortillas all the time.”

PUCHARO—Water, beef, *garbancos* (chick peas), pork, ham, salt and pepper, leeks, celery, parsley, mint, cloves, garlic, cabbage, pumpkin, and a large *choriso* (Bologna sausage); all boiled for different lengths of time. Peas and meat served together and soup aside. MEXICAN MUTTON WITH BEANS—Leg of mutton with garlic inserted; the outside fried brown, broth and gravy added with chillies, onions, aromatics, simmered in the gravy 2 hours; served with purée of Mexican black beans. TORTILLAS—Corn cakes.

MICHAEL ANGELO'S PUDDING—Curd of milk turned with rennet, with fruits, boiled like a plum pudding. Made of 2½ lbs. firm drained curd, 10 eggs, 1 lb. raisins, ¼ lb. each preserved green-gage, apricot and cherries, 6 oz. each sugar and bread-crumbs, 3 oz. citron, 1 glass each brandy and rum, mixed well, in cloth or mould, boiled or steamed 5 hours; brandy sauce.

MIGNON, FILET—Minion or small fillet. Sometimes in the *menu* it means a small tenderloin beefsteak. If of fowl it signifies the smaller of the two natural divisions of the meat of the breast.

MIGNONETTE—One of the perplexing terms in cookery directions, as it is confounded with a plant of that name. It means pepper broken or coarsely ground, so that it can be strained out of the sauces again and not remain as powdered pepper would.

MILANAISE GARNISH—Strips of macaroni, ham, chicken, truffles, in white sauce with grated Parmesan. Dishes finished with this garnish are *a la Milanaise*.

MILK—SKIMMED OR WATERED MILK—To detect whether the cream has been removed to any great extent, the old form of lactometer, now more properly called a *creamometer*, may be used. This instrument consists simply of a long tubular glass, divided by markings into one hundred equal parts. The milk to be tested should be poured into this glass up to the topmost division, and set aside for from 10 to 12 hours in summer, or from 15 to 16 in winter; this will allow ample time for the whole of the cream to arise, and the stratum thus separated ought to measure from 8 to 8½ divisions on the glass—*i. e.*, good milk should have from 8 to 8½ per cent. of cream. If the quantity of cream registers only 6½ per cent., either some of it must have been abstracted, or 33 per cent. of water may have been added to the milk. In like manner 5 per cent. of cream shows that the milk has been robbed of from 3 to 3½ per cent., or diluted with 50 per cent. of water. But the milk of many varieties of cows is

## MIL

often considerably richer; it reaches in the Alderney breed to as much as 18 per cent., and in certain of the Scandinavian cows, which are fed on the rich mountain pastures during summer and on the same fodder collected in silos in winter, an average quite as high is maintained perpetually. **STARCH IN MILK**—Very rarely it has been stated that dishonest dealers add starch to the milk to remove the bluish tinge due to previous dilution with water; but this can easily be detected by the addition of a drop or two of tincture of iodine from the medicine chest, which every well-regulated hotel ought to be provided with. If starch be present the milk will turn blue. **CHALK IN MILK**—Sometimes chalk has been added to correct the acidity of milk which has "turned," and also to give it "body;" this form of adulteration is happily of very rare occurrence, and can be at once detected by the practiced palate of any one accustomed to the pure article. If suspected, the milk should be allowed to stand aside in a quiet place in a tumbler, and, if chalk has been added, a deposit will accumulate. Pour off the top without disturbing the sediment; pour in a little water and allow it to settle. Repeat this again and a white powder will be left, which will effervesce when acid is added to it. As a confirmatory test, add acetic acid to the sediment; it will effervesce and finally dissolve up the chalk, and if to the clear solution thus produced a little oxalate of ammonia solution is poured in, it will finally demonstrate the presence of chalk by throwing down a white precipitate. **A GERMAN TEST**—For watered milk, consists in dipping a well-polished knitting-needle into a deep vessel of milk, and then immediately withdrawing it in an upright position. If the milk is pure, a drop of the fluid will hang to the needle; but the addition of even a small portion of water will prevent the adherence of the drop. **CONDENSED MILK**—Is 4 qts. of cow's milk from which 3 qts. of water are evaporated, leaving 1 qt. of the solid constituents of milk, to which is added a sufficient quantity of sugar to preserve and conserve it. All condensed milk thickens with age in the hermetically sealed can, but a little stirring returns it at once to its former consistency. Milk, although thickened in the can, is in no manner stale nor injured. **UNSWEETENED CONDENSED MILK**—Is evaporated milk preserved by the addition of boracic acid and other chemicals, which give it a very slight saline taste. It is of the consistency of cream, will keep about a month, and is useful in localities where fresh milk is scarce. It is shipped in cans from the places of manufacture in New York and branch houses. It, of course, needs to be diluted with water, but serves as a substitute for cream as it is. **DRIED MILK**—It is stated that milk has been successfully solidified and then powdered or made up in lumps. In either form it is claimed to keep well, and henceforth milk is expected to be sold, to some extent, in a dry form like sugar. The desiccated milk, as we may term it, represents fresh cow's milk in the highest form

## MIN

of concentration, and it may be kept an indefinite time without deterioration. Three varieties are tinned, viz., unskimmed, skimmed, and sweetened milks, and the milk-powder is also combined with coffee, chocolate, and tea to form dry preparations of distinct dietetic value. The milk in powder dissolves quite readily in warm table beverages. **DRIED MILK-PREPARATIONS**—Milk cannot be condensed more than three-fourths without some admixture to preserve its solubility, as it all turns to a kind of cheese. It may be kept soluble by the addition of sugar, and to a further degree by the addition of dried white of egg. With these two additions it may be evaporated to dryness, and finally powdered and kept, and dissolves easily. Only skimmed milk should be so prepared; the cream would make it oily and rancid in a short time. With this dried or candied milk as a basis several culinary preparations in a powdered state can be made, as custard mixtures with dried eggs, blanc-mange with gelatine, etc., needing nothing but hot water in the prescribed proportion to make the article as required. **MILK SOUP**—See *Soups*. **MILK SHAKE**—A good trade is done in this in summer time. A milk shake is  $\frac{1}{2}$  pt. milk in a large lemonade-glass, a spoonful sugar, shaved ice, flavor if requested; covered and shaken to froth. There are machines for shaking them up 3 or 4 at once by the turn of a wheel. **MILK PUNCH**—See *Drinks*. **MILK WINE**—See *Koumiss*.

**MILT**—The soft roe of fish.

**MINCEMEAT**—Good quality is made of 3 lbs. boiled beef, 3 lbs. suet, 4 lbs. apples, 4 lbs. raisins, 2 lbs. currants, 1 lb. citron,  $\frac{1}{4}$  lb. each lemon and orange peel, juice of 4 oranges and 4 lemons, 4 lbs. sugar, 2 nutmegs, 1 teaspoon each ground allspice, cloves, cinnamon, mace, pepper, 2 tablespoons salt; ingredients chopped fine; cider enough to moisten. **LEMON MINCEMEAT**—Two lemons, 4 sharp apples,  $\frac{1}{2}$  lb. suet, 1 lb. currants,  $\frac{1}{2}$  lb. sugar, 2 oz. each candied lemon peel and citron,  $\frac{1}{2}$  nutmeg, pinch of mace; the lemons to be pared and rind boiled, then minced; juice added to the other ingredients; no meat; stand a week before using; brandy if desired.

**MINT SAUCE**—Chopped green mint, vinegar and sugar; mixed and served cold. This is the sauce for cold lamb and mutton in England and France, but is eaten with hot roast lamb in this country where cold meats are not in favor. **IMPROVED MINT SAUCE**—An 'Old Bohemian' observes: "When I talk of mint sauce, I do not mean the wretched mess of a few imperfectly chopped dry mint-leaves swimming about in a sea of malt vinegar, with a few grains of raw sugar dissolved in it, which one gets in some dining-rooms, and occasionally even at private tables, and which has its admirers, too, among some *chefs* and blue ribbons, who coolly tell you that half an ounce of moist sugar will do for five fluid ounces of malt vinegar. I recommend the following recipe: Take a sufficiently large bunch of fresh green young

## MIR

mint to fill, when finely chopped, two to three table-spoonfuls; chop the rind of a good-sized lemon very fine, and add it to the mint in a sauce-tureen; to four ounces of best French vinegar add one ounce and a half of fresh lemon juice, and dissolve in this as much finely powdered best loaf-sugar as it will absorb; pour the solution over the mint in the tureen, and let it stand an hour or so."

**MIREPOIX** (Fr.)—A brown broth or unthickened gravy made to braise meats in to give them a high flavor; made of veal, bacon, ham, onions, carrots, aromatics, wine, broth, butter, salt, pepper. The meats, etc., cut and fried brown in the butter, wine and broth added, simmered; liquor strained off is the *mirepoix*.

**MIRLITONS** (Fr.)—Tartlets in patty pans with a pastry bottom crust and filled with very rich custard; much the same as maids of honor. **MIRLITONS AUX FLEURS D'ORANGER**—Little patties of puff paste filled with a mixture of butter, sugar and eggs worked up together, powdered macaroons added to make a paste of it, candid orange flowers for flavor. **MIRLITONS DE ROUEN**—Little puff paste patties filled with egg, thick cream and sugar in equal parts, beaten and flavored, sugar sifted plentifully on top as they are put in the oven.

**MIROTON** (Fr.)—Dish of sliced fish, meat or fruit. **MIROTON DE HOMARD**—Slices of lobster meat dipped in salad sauce and served on salad. **MIROTON DE BŒUF**—Slices of cooked beef in a dish with savory sauce, covered with bread crumbs and baked. **MIROTON DE POMMES**—Apples cut in ring slices built up in dome form in a baking dish, inside filled with apple and peach marmalade, baked till done, sugar sifted over, served in the same dish with folded napkin around it or paper frill.

**MOCK CRAB**—Cheese, bread crumbs, butter, vinegar, cayenne and salt, with an egg, made up to resemble devilled crabs, baked in shells.

**MOCK DUCK**—Thin beef steak covered with duck stuffing, rolled up, tied, cooked tender in gravy in the oven.

**MOCK TURTLE SOUP**—Made of beef stock with calf's head boiled in it. The head boned and pressed, cut in dice when cold and put in the soup to substitute turtle. (*See Soups.*)

**MËLLE** (Fr.)—Marrow. **SAUCE MËLLE**—Marrow sauce.

**MONSELET, CHARLES**—"The Prince of Parisian *gourmets*, and one of the few men on whom the mantle of Brillat-Savarin descended, has recently died. Charles Monselet was born at Nantes, and spent his early years in the shop of his father, who was a bookseller. After many struggles he worked his way up to the foremost rank of journalism, and was one of the liveliest *chroniquerus* on art, letters, and good living in Paris. His articles were full of wit, point, and piquancy. Saint-Beuve used to say

## MON

to him, 'Resumez vous, Monselet, and write a book.' 'There are so many books,' was the answer, 'that I abhor to add to their number.' Nevertheless the lively chronicler became a voluminous contributor to book literature, without adding in any degree to his reputation as a writer. In order to revive the traditions of Brillat-Savarin and Grimod de la Reyniere, he wrote the 'Almanach des Gourmands,' and the 'Cuisine Poetique.' He also founded a magazine, *Le Gourmet*, which did not live; but Monselet as has been well said, never invented a new dish nor wrote a solid book."

**MONTE SANO CAKE**—Variation of angel cake. Has butter in it. Equally as white but not quite so woolly. Is shorter eating, better to roll up for white jelly roll. Choice cake in any shape. Made of 42 whites, 2½ lbs. sugar, 1½ lbs. flour, ½ lb. butter, 4 teaspoons cream tarter; flavoring. Make up like angel cake, have the butter melted, not hot, and beat it in after the flour.

**MONTPELLIER BUTTER**—Green butter, served cold as sauce for fish, lobster, etc. Made of green herbs—tarragon, chervil, pimperl, chives—scalded, drained and pounded; garlic, capers, hard yolks, anchovies, gherkins, butter, salt, pepper, nutmeg and tarragon vinegar worked into the paste at last.

**MONKEY**—"In Spanish Honduras the dish of honor is baked monkey, and sweeter meat you could not imagine. These monkeys live up in the branches of trees and on the vines; their feet never touch the earth beneath them, and they live on the choicest nuts and fruit. No chicken was ever so sweet and tender as baked monkey." "The Anamite Tuduc, just deceased, was a curiosity among Emperors. The two chief institutions of his palace were his harem and his kitchen. He was an old man, and only allowed his sacred face to be seen by mandarins of high rank. His principal meal consisted of never fewer than twenty courses, among which was his favorite delicacy of roast monkey. He frequently received a fatted ape from his subjects as a present, and nothing was more acceptable. His manner of daily life was said to be more uxurious than that of his over lord, the Emperor of China." "Here is a Mandingo (African) bill of fare which Reade, the explorer, leaves on record for the amusement of the curious. 'Then followed,' he says, 'gazelle cutlets a la papillots; two small monkeys, served cross-legged and with liver sauce on toast; stewed iguana, which was much admired; a dish of roasted crocodile's eggs; some slices of smoked elephant (from the interior); a few agreeable plates of fried locusts, land crabs and other crustacæ; the breasts of mermaid, or manatee, the grand *bonne-bouche* of the repast; some boiled alligator and some hippopotamus steaks.' While this dinner does not equal in courses some of the elaborate feasts of civilized lands, certainly no one will say that it lacked variety."



## MON

**MONTE SANO PUDDING**—Excellent example of a soufflé, and one of the best puddings ever made; composed of 3 oz. flour, 3 oz. sugar, 3 oz. butter, 3 eggs, 1 pt. boiling milk. The eggs separated; the yolks, sugar, butter and flour stirred together like cake, boiling milk poured into the mixture. When cool, the whites whipped stiff and mixed in; baked in a pudding dish; wine sauce. It may perhaps require a little more milk if too stiff to take in the whites. Is like yellow sponge cake, but soft.

**MONTREAL PUDDING**—Steamed raisin pudding, made of 1 lb. bread-crumbs, 3 oz. sugar, 6 eggs, 1 pt. milk, 1 lb. raisins, ½ lb. flour; steamed 3 hours.

**MOREL**—A kind of mushroom with a netted surface, something like a piece of sponge on a stem. They are stewed, fried, added to sauces. **MORILLES AUX CROUTONS**—Morels stewed, and served with the sauce on buttered toast. **MORILLES A L'ANDA LOUSE**—Morels cooked with oil, wine, ham, and served in the sauce. **MORILLES A L'ITALIENNE**—Served with Italian sauce.

**MORUE** (Fr.)—Salt cod.

**MOTSA BREAD**—See *Jewish Cookery*.

**MOULE** (Fr.)—Mould. **MOULE D'ASPIC A LA ROYALE**—A mould of round slices of chicken, truffles, mushrooms, cock's-combs, white of egg in shapes, cream sauce and aspic jelly to fill up and set it.

**MOULES** (Fr.)—Mussels. **SAUCE MOULES**—Mussel sauce.

**MOUSSE** (Fr.)—Moss; froth; something very light and spongy. The term is both to meat preparations and to ice creams; there are *mousses* of *foie gras*, the softened paste having whipped cream mixed in it and then made cold, as well as *biscuits glaces* and *mousses glaces*. (See *Ices*.) **MOUSSE ICE-**



INDIVIDUAL MOULD.

For mousses, muscovites, jellies, etc.

**CREAM**—Made by putting 8 yolks in a pint of strong sugar syrup (34 degrees) and whipping them over the fire until nearly boiling, but must not quite boil; then set the kettle in ice and salt, and continue whipping until nearly frozen; then a pint of thick cream is whipped and mixed into the other, along with whatever flavoring is wanted. It is not frozen in a freezer, nor worked any more, but put in a mould and buried in freezing mixture till wanted. The mould to be lined with thin white paper. **MOUSSE**

## MUL

**DE HOMARD**—Lobster meat with seasonings of lemon juice, etc., pounded through a seive, stirred up with a little butter; when nearly cold, some whipped cream incorporated with the purée, filled into small moulds; served cold. **MOUSSE DE CREVETTES**—Shrimps same way as lobster. (See *Souffles, Pains*.) **GELEE MOUSSEUSE A L'EAU DE VIE**—Brandy jelly, whipped to froth. **MOUSSE AUX FRAISES**—Whipped cream with strawberries, not frozen.

**MOUSSERONS** (Fr.)—Mushrooms; the large or full-grown open ones. *Champignons* are small or button mushrooms.

**MOUSQUETAIRE SAUCE**—Cold or salad sauce of oil, tarragon vinegar, mustard, shallot, salt, and pepper.

**MOUTARDE** (Fr.)—Mustard.

**MUD-PUPPY**—“Another delicacy is the mud-puppy, which comes from Ohio. It is a lower form of lizard than the hell-bender. It is a foot long, with a lizard-like body, and a long, exceedingly slabsided thin tail, with which it propels itself in the water with great rapidity. On the back of its head are gill tufts. When the mud-puppy is too long out of water, the tufts dry, and it dies from want of breath. Its feet are funny little things that straddle and sprawl around like a puppy's. But the reason why it is called a mud-puppy is that, when fishermen wandering with fish-spears along the borders of Western lakes and streams happen to bring up a mud-puppy, it utters short, sharp barks.”

**MUFFIN**—The original English muffins are a flour batter-cake mixture, without eggs, raised with yeast and very light baked by pouring into tin rings set upon a hot griddle, or baking plate, and turned over when one side is done. When to be eaten, they are pulled open, and the two halves toasted and served hot. American muffins are the same batter-cake mixture made richer, baked in gem-pans or small muffin-rings, or are made of a piece of light bread dough reduced to thinness with warm milk, and enriched with sugar, butter and eggs, and baked as before. There are all sorts, as corn, wheat, graham, rice and rye muffins. **MINUTE MUFFINS**—One pint milk, 2 beaten eggs, 2 tablespoons melted butter, 1 tablespoon sugar, 2 large teaspoons baking-powder, flour to make a batter that will just drop from the spoon.

**MULBERRY**—“According to the doctors, the best fruit to eat at breakfast is a plate of mulberries. They contain more acid than most fruits, and yet are sweet and easily digestible.” In the United States the mulberry is held of little value; it is not often served as dessert, and a mulberry pie would be accounted one of the poorest. This is probably owing to the abundance of better fruit at the same season, and not that the mulberry is the worse here than in Europe where it is used in various ways. The best use to be made of it in cooking is to mix it with some sour fruit, apples or rhubarb, when it makes excellent pies and roly-polys.

## MUL

MULET (Fr.)—Gray mullet.

MULLET—There are two fishes of the name, the red and gray mullet. The latter is one of the most abundant sea-fish of the southern coasts, and is cheap and but little esteemed accordingly. It is of good flavor, especially in the winter season; its flesh is rather dark and does not color as handsomely in the processes of cooking as most other fish. The red mullet is found in the same localities, but in very limited quantities, and is seldom seen in the markets. RED MULLET—"Most cooks make no distinction in dressing the red and gray mullet; though the former is cooked woodcock fashion, without drawing, so delicate is the fish." "If you get red mullet fresh from the sea, dress them as is done with woodcock, retaining the trail; but inland this is not a safe proceeding." "A lover of mullet, the late Duke of Portland, was in the habit of going to Weymouth during the summer months for the sake of the red mullet which formerly abounded there. The largest used to be had for threepence or fourpence apiece; but he has been known to give two guineas for one weighing a pound and a half. His Grace's custom was to put all the livers together into a butter-boat, to avoid the chances of inequality; very properly considering that, to be helped to a mullet in the condition of an East Indian nabob, would be too severe a shock for the nerves or spirits of any man." MULLET LIVER—"Quinn the actor used to declare that the mullet was only created for its liver to serve as sauce to the john dory." "A large mullet may be cut into fillets and fried, and served with sliced cucumber. The livers are the only sauce to be eaten with mullet," MARCUS APICIUS ON MULLET—"The Romans served the mullet with a seasoning of pepper, rue, onions, dates, and mustard, to which they added the flesh of the sea-hedgehog reduced to a pulp, and oil." "Red mullets are the favorite fish in Greece. They are cooked in oil, with garlic, parsley and cayenne pepper; you then strain tomatoes and make a good sauce, and let the fish cook in it very slowly, adding lemon juice."—ROUGETS EN CAISSE—Red mullets sprinkled with oil and parsley, broiled in papers. ROUGETS EN PAPILOTES—Red mullets baked in papers, served with Italian sauce. ROUGETS AUX FINES HERBES—Red mullets cooked with butter, wine, mushroom-catsup and anchovy; served in the sauce with chopped mushrooms, parsley, shallot, and lemon juice. FILLETS DE ROUGETS A LA MONTESQUIEU—Red mullet fillets sauté in butter with wine and lemon juice; served with cream sauce. MULETS GRILLES A LA RAVIGOTE Gray mullet broiled, and served with ravigote sauce. MULETS AU BEURRE FONDU—Gray mullet broiled, served with butter sauce. They are also cut in pieces, rolled in flour and fried, and split open, broiled, and served with *maitre d'hotel* butter. UDE AND HIS MULLET SAUCE—Ude considered it a great insult when in England a customer at the club refused to pay sixpence for a sauce. "Wouldn't pay for my mullet

## MUS

sauce!" he exclaimed, "what, does he think mullets come out of the sea with my sauce in their pockets?"

MULLIGATAWNY—Curry soup. Also spelled mullagatawne. It derives its name from two Tamil words: *molegoo*, pepper, and *timnee*, water. "Mulligatunny" would therefore appear to be the proper spelling. WRITTEN IN 1827—"Mullaga-tawny signifies pepper-water. The progress of inexperienced peripatetic diners-out has lately been arrested by this outlandish word being pasted on the windows of our coffee-houses. It has, we believe, answered the *restauranteurs'* purpose, and often excited John Bull to walk in and taste—the more familiar name of 'curry soup' would, perhaps, not have had sufficient of the charms of novelty to seduce him from his much-loved mock-turtle." The American way is to begin as for gumbo by frying the pieces of chicken and onion and curry-powder together; another method boils the chicken and other meat, such as a calf's head, first, then cuts it up and fries it with onions and curry, straining the broth the meat was boiled in to it. "The annexed recipe emanates from an Indian cook: Make 2 large cupfuls of mutton broth; cut up a chicken, and boil it in the broth for a good half-hour or more, first mixing in a tablespoonful of curry-powder or paste; slice 2 onions, fry brown in 1 oz. of butter, add them to the chicken and broth, and place them for some minutes over a slow fire, and, just before serving, add ½ cup of cocoanut milk and some lemon juice. The cocoanut milk should be made by scraping the cocoanut very fine, pouring boiling water upon it, and, after it has stood for some time, squeezing it through muslin. If you cannot get a cocoanut, use cream."

MUSCOVITES—Whipped jellies; Moscow jellies, from whipped jelly having at first been called Russian jelly. These are combinations of jelly and ice cream made by adding gelatine to fruit juice or pulp and beating on ice till nearly set when mixing in whipped cream, putting it in a mould and burying in freezing mixture for 2 or 3 hours. (*See Ices.*)

MUSHROOM—"I am a mushroom enthusiast. Danger of poison? Not a bit of it. With the exercise of a little common sense there is no danger of mistaking the edible variety for those that are poisonous. All toadstools, technically speaking, are mushrooms, but all mushrooms are not toadstools. Popular custom has given the name of mushroom only to the variety used in the kitchen. I have seen both sorts growing side by side, and exactly similar in appearance, but the difference is soon apparent when you attempt to remove the skin. You can't skin a toadstool; it will break off in small fragments. The covering of the non-poisonous, on the contrary, can be removed without the slightest difficulty. Mushrooms are extensively cultivated in France, but I did not know until recently that a similar industry was practised in this city (Philadelphia). I had frequently noticed on Boldt's bill of fare, even in the depth of winter, 'fresh mushrooms,' and

## MUS

this naturally led to inquiry. I found that there are four or five persons in Philadelphia who make a business of cultivating the delicious fungi, and that in addition quite a large number of private house holders grow them in their cellars. One gardener utilizes a large Dock Street cellar for the purpose. A down-town truckman forces them to grow under the glass of a hot-house. An old Frenchwoman and her daughter down in 'The Neck' are more successful than all others, they having a bed made in an enclosed cow-shed. The largest grower is J. E. Kingsley, of the Continental Hotel, who has a large farm in addition to the biggest hotel in town. Those who grow them here receive from \$1.00 to \$1.50 per quart for them, and on some occasions even higher figures are obtained. When you come to eat them in the *cafe* a one-dollar note buys you about two mushrooms, and yet at that figure they do not even approach the delicacy of flavor and deliciousness of taste of the same growth when purchased in the open market house for from 10 to 25 cents a quart. I tell you it is almost impossible to counterfeit nature. For instance, what a mockery are the canned mushrooms that so many people eat under a wild idea that they are enjoying a luxury! They are of a different species from our wild mushrooms, and are cultivated in immense caves near Paris. When in their early or button growth they are canned and sent to this country, where they are served in sauces. But what a delusion! To one whose palate can quickly appreciate the delicacy of the true article they taste as though one were chewing on preserved shavings. On a vacant plot of building land in the immediate neighborhood of the Harrow road and within four miles of Charing Cross is produced annually what is probably the most valuable crop grown in the open air and without the aid of glass on any acre of English soil. The space occupied is, indeed, rather more than an acre, the rent being just £12 a year, but the space devoted to mushrooms and manure is under an acre, and the uninitiated will be astonished to learn that from this small plot has been gathered in the last twelve months about twelve thousand pounds weight of mushrooms, all of which have been sold at Covent Garden at a price varying according to the season, but averaging ten-pence a pound for the whole year. Now, the value of twelve thousand pounds at ten-pence per pound is just five hundred pounds sterling. We have therefore the amazing circumstance that an acre of our metropolitan area has produced a richer garden crop than the cosiest corner of Kent or the most favored nook on Lord Sudeley's jam farm in Gloucestershire." A SIMPLE RULE—"Make it a rule not to touch a mushroom whose lower gills are white." MUSHROOMS ON THE GRILL—The smallest buttons of the real mushroom (*agaricus campestris*) are, as everybody knows, delicious if nicely broiled, but for a prime dish of mushrooms from the grill, whether to eat alone or with a kidney, or steak, or cutlet, we prefer them

## MUS

fully grown, so that the brown gills are quite exposed; for in the buttons the gills are hidden by a membrane, which disappears as the head expands and rends it asunder. MUSHROOMS ON TOAST—Slices of buttered toast covered with fresh mushrooms, which have been dipped in butter and seasoned, set in the top part of a hot oven till cooked. STUFFED MUSHROOMS—Open, cup-shaped fresh mushrooms peeled on the upper side, washed, the stalks chopped with parsley and shallots, stirred over fire with butter and thickening, the mushrooms filled with this stuffing and baked about 10 minutes. CROUSTADES OF MUSHROOMS—Cup-shapes of fried bread or rolls filled with mushrooms in sauce; the mushrooms cooked with butter, parsley, chives, salt, pepper, stock, and thickened with yolk of egg; little lemon juice. BROILED MUSHROOMS—Large open mushrooms steeped in oil for an hour, broiled on wire broiler, seasoned; served on toast. VEGETARIAN MUSHROOM PIE—Equal quantities of fresh mushrooms and sliced raw potatoes in a buttered



MUSHROOMS.

pie dish with seasonings, little water, covered with paste, baked. Stalks of mushrooms stewed to make gravy to pour in the pie. WHERE MUSHROOMS ARE UNDERSTOOD—"A strange variety of taste has prevailed in various countries in regard to mushrooms. In Russia the peasants are never without them. They are hung up to dry in the roofs of the cottages like oat-cake in Lancashire, and form a greatly esteemed relish to all sorts of dishes. In some parts of Germany, also, they are largely preserved in brine for cooking purposes. In England, however, it is only lately that they have come at all into general use." THE BEEFSTEAK MUSHROOM—"Amongst edible members of the mushroom tribe, a much esteemed article of diet, is the beefsteak fungus (*fistulina hepatica*). It grows on trees, usually oak, is firm and juicy, and, as its popular name indicates, bear a great resemblance to a piece of beefsteak. Its weight may exceed 20 lbs. It is used sliced and eaten with salad, or grilled like true mushrooms." THE ONION TEST—There are many varieties of the true mushroom and of the horse-mushroom, but all are equally good for table. To distinguish between these and noxious fungi, the

## MUS

following test is recommended: Take half an onion, stripped of its external skin, and boil it with the mushrooms; if the color of the onion is changed and it becomes bluish, or tinged with black, it is an evident sign that poisonous fungi are present. If the onion preserves its color there is no danger. **MUSHROOM KETCHUP OR CATSUP**—Large field mushrooms peeled, crushed to a pulp, 1 tablespoon salt to every quart; let stand 24 hours, the liquor drained off and to every quart of it 20 cloves, 30 each pepper corns and allspice; boiled gently  $\frac{1}{2}$  hour, bottled, corked when cold. Will keep a long time. **DRIED MUSHROOMS**—These can be bought at Italian warehouses and fruit stores, and give more true mushroom flavor for sauces and garnishes than the canned champignons. Mushrooms can be dried, after peeling and trimming, on pans in a nearly cold baker's oven, and kept in paper bags. **MUSHROOM PATTIES**—Puff-paste shells filled with cut-up mushrooms in gravy. **BAKED MUSHROOMS**—Peeled, cup-shaped mushrooms hollow side upwards in a pan with butter in each one, salt and pepper, parsley and lemon juice. "Two mushrooms, each measuring  $2\frac{1}{2}$  inches in circumference and 9 inches in diameter, and weighing fully 13 ounces, have been gathered from the farm of James Bower, at Hapsford, Cheshire. These are believed to be the largest mushrooms ever known to have been seen in England."

**MUSK ESSENCE**—Used in flavoring drinks in some places, also jellies and creams; it has been temporarily the fashion.

**MUSKRAT**—An old Maryland gentleman, who is somewhat of an epicure, says that between turkey and muskrat he will take muskrat all the time. The way the Indians cooked this animal was either to roast it on coals or boil it with corn. The average man will say that he would not eat a muskrat for \$10, but the average man does not know what he is talking about. An ordinary cook, however, will get nothing from the rodent except a failure and a bad odor. If the musk bag is cut and the scent is imparted to the meat it becomes worthless.

**MUSSEL**—Bivalve shell-fish, shell about the length of a finger; nearly black, clings in clusters to rocks and wooden piles of wharves. **TRADE IN MUSSELS**—"All along the Norman coast mussel-fishing is greatly carried on, these shell-fish being sent from here to all parts of the country. They are at their best in July. The usual way of eating them is boiled, with a sauce of cream and vinegar." **MUSSELS AU GRATIN**—A great deal has been recently said about mussels and the various ways of cooking these fish, whose cheapness and abundance put them within the reach of all. One of the tastiest ways of preparing mussels is *au gratin*, for which the following is the recipe: Choose some fine mussels; season with thyme, laurel-leaf, and parsley; cook. Select fattest, and treat these only. Shell, and cover with a bechamel sauce much reduced,

## MUS

with yolks and cheese grated over. Glaze in a hot oven and serve immediately. **MUSSELS A LA MARI-NIERE**—After a few minutes steaming or broiling, take the mussels out of their shells, and toss them in a saucepan with a large lump of butter and finely chopped parsley, chives, and garlic; stir in a little black pepper and bread crumbs. Serve very hot. **MOULES A LA POULETTE**—Mussels in yellow sauce. **MOULES A LA VILLEROI**—Fried mussels, dipped before frying in Villeroi sauce; then breaded, egged, and breaded. **MOULES DE GRAS**—Mussels stewed with bacon and mushrooms, in thickened sauce. **COQUILLES DE MOULES**—Scalloped mussels same as oysters. **MUSSELS WITH TOMATOES**—Mussels and their liquor, tomatoes, onion, half-fried in butter, white sauce, red and white pepper, salt, butter, little vinegar, parsley; served in deep dish with crutons. **MUSSEL SOUPS**—Same as oyster soups, with or without milk. **MUSSEL SAUCE**—For fish; like oyster sauce; mussels in yellow sauce with lemon juice.

**MUSTARD**—Flour, made of the mixed seed of black and white mustard, deprived of its mustard oil and toned down with more or less meal or farina. **TO MIX MUSTARD**—Merely wet it with cold water. Epicures sometimes mix mustard with sherry or raisin wine. The French mix it with tarragon, shallot and other flavoring vinegars, and pepper. **SHAKSPEAREAN QUOTATION**—In Shakspeare's time the *gourmets* of the period ate mustard with pancakes. Touchstone puts the case "of a certain knight that swore by his honor they were good pancakes, and swore by his honor the mustard was naught. Now, I'll stand to it, the pancakes were naught and the mustard was good, yet was not the knight forsworn." **MUSTARD FOR BALDNESS**—Gerard wrote about the same period: "The seed of mustard pound with vinegar is an excellent sauce, good to be eaten with any gross meats, either fish or fleshe, because it doth help the digestion, warmeth stomache, and provoketh appetite. It also appeaseth the toothache being chewed in the mouth. It helpeth those that have their hair pulled off; it taketh away the blue and black marks that come of bruising." **MUSTARD OIL LINIMENTS**—The bulk of the mustard oil is used for lubricating purposes, though a large proportion, differently treated and put up as a patent medicine, is used medicinally for rheumatics and other ailments of the joints and limbs. **MUSTARD PLASTER**—Mix the mustard with the white of an egg, and all painful irritation will be done away with and the full benefit secured. **MUSTARD EMETIC**—Mustard in warm water is often an efficient and ready antidote in the case of poison. **WHY IT IS DURHAM MUSTARD**—Prior to the date of about 1720 the seed was coarsely pounded in a mortar, as coarsely separated from the integument, and in that rough state prepared for use. In the year mentioned, it occurred to an old woman of the name of Clements, residing in Durham, to grind the seed in a mill, and pass it through the several processes which are re-

## MUT

sorted to in making flour from wheat. George I. stamped it with fashion by his approval. From this old lady residing in Durham it acquired the name of "Durham Mustard." **MUSTARD IN SAUCES**—When it is desirable to put mustard in a sauce, as in Robert sauce for instance, mustard flour, that is, unmade mustard, must always be used. Put a little of the sauce or stock, in a cup, stir in the mustard flour, and then work in with the rest of the sauce. **MUSTARD SAUCE**—For fish. (1)—Raw mustard mixed with milk and little salt, more milk added and then vinegar. In short time the milk becomes thick by curdling, and is ready for use; 1 teaspoon flour mustard to  $\frac{1}{2}$  pt. milk. (2)—1 teaspoon mustard flour and 2 of baked flour with 3 oz. butter, 1 gill boiling water added, boiled; 1 teaspoon vinegar to finish. Douglas Jerrold once went to a party given by a Mr. Pepper, and said to his host, on entering the room, "My dear Pepper, how glad you must be to see all your friends mustered."

**MUTTON**—"Liston was asked by a gentleman carving a loin of mutton: 'Shall I cut it saddlewise?' 'You had better cut it bridewise,' replied the famous actor, 'then we shall all stand a better chance of getting a *bit* in our mouths.'" **A WELSHMAN'S HEAVEN**—"Heaven," said a Welsh preacher, searching hard for a comparison, 'Heaven is like—is like—is like—heaven is like—boiled mutton and turnips!' But the Cambrian heaven is still incomplete if caper sauce be lacking to it." **HARICOT DE MOUTON**—Same as *Navarin*. Specialty. "The restaurant department of the Café Helder is good, being especially famed for its *ragout* of mutton, *haricot de mouton*, or *navarin*, as it is here called."—**NAVARIN DE MOUTON**—For some reason the old-fashioned name *haricot* has fallen into disuse; *navarin* is mentioned to be a more dignified appellation. Made of the shoulder, breast and neck of mutton or lamb cut in square pieces and fried on all sides in fat; the fat poured off, flour shaken in the meat, broth and tomato sauce added. In another pan several sorts of vegetables in small pieces fried in butter with sugar to give color; vegetables, herbs and meat then put together and simmered about 2 hours; small potatoes added last. **ROLLED BREAST OF MUTTON**—Boned, chicken stuffing spread upon it, rolled up and tied, baked in gravy 3 hours. **COTELETTES DE MOUTON A LA JARDINIÈRE**—Mutton chops with jardiniere garnish. **COTELETTES DE MOUTON A LA SOUBISE**—Chops with purée of onions. **COTELETTES DE MOUTON A LA PROVENCALE**—Chops coated with thick sauce of onions, garlic, butter, eggs, cheese; breaded and fried. **COTELETTES A LA VICOMTESSE**—Chops coated with thick sauce of ham, mushrooms, yolks, stock; breaded, fried, paper frills on bones. **COTELETTES AUX PETITES RACINES**—Chops on a border of mashed potatoes, with carrots and turnips in long shapes in brown sauce. **COTELETTES AUX TRUFFES**—Chops with truffles cut in slices in brown sauce. **COTELETTES PANÉES GRILLÉES**—Breaded chops broiled. **COTELETTES AUX POINTES D'AS-**

## MUT

**PERGES**—Broiled chops with asparagus tips in butter. **COTELETTES A LA DURCELLE**—Chops baked in long paper cases, three in each; mushrooms, onions, brown sauce, parsley. **COTELETTES A LA MARSEILLAISE**—Coated with cold purée of onions; breaded and browned in the oven; Soubise sauce. **COTELETTES A LA BOHEMIENNE**—Chops marinated, breaded, broiled; sauce made of some of the marinade with tomato and brown sauce and currant jelly. **COTELETTES EN ROBE DE CHAMBRE**—Chops coated with veal forcemeat, eggs, and breaded; browned in oven; gravy sauce. **COTELETTES A LA REFORME**—Chops breaded with chopped or grated ham mixed with the crumbs, fried, and served with réforme garnish. **COTELETTES A LA MARQUISE**—Chops with a slice of ham laid on each, and veal forcemeat spread on it; breaded on top, and browned; white sauce with chopped ham. **COTELETTES A LA FINANCIERE**—Chops braised, served with financiere garnish.—**COTELETTES A LA NELSON**—Chops breaded with Parmesan cheese in the crumbs, fried, served on border of mashed potatoes, center filled with macaroni and cheese. **COTELETTES A LA MAINTENON**—Chops wrapped and served in paper; they having been previously sautéed in butter, with mushrooms, parsley, shallots, brown sauce and lemon juice added, some of the garnish twisted up with each chop; baked or broiled. **COTELETTES A LA PRINCE DE GALLES**—Pieces of stewed breast of mutton breaded and fried; served with mashed turnips and gravy. **ESCALOPES DE MOUTON AUX FINES HERBES**—Slices of mutton from the chump end of the loin cooked in a pan in butter, strewn over with chopped shallots, parsley and mushrooms. **FILETS DE MOUTON A LA MACEDOINE**—The meat of the loin larded, braised, served with macedoine garnish. **CARBONADE DE MOUTON, SAUCE PIQUANTE**—Loin of mutton cut in chops, sautéed, served with sauce. **HANCHE DE MOUTON AU JUS DE GROSEILLES**—Haunch of mutton with gravy and currant jelly. **QUARTIER DE MOUTON A LA BRETONNE**—Fore quarter with white beans. **SELLE DE MOUTON A L'ANGLAISE**—Roast saddle of mutton. **GIGOT BOUILLI**—Boiled leg of mutton with turnips. **GIGOT SAUCE AUX CAPRES**—Boiled mutton, caper sauce. **LEG OF MUTTON A LA MEXICAINE**—Mutton with black beans. **LEG OF MUTTON A LA BIGNON**—Roasted with a clove of garlic inserted in the fleshy part; served with Bignon potatoes. **MUTTON LIKE VENISON**—Loin of mutton boned, soaked for 2 or 3 days in little port wine, basted with wine; served with gravy and currant jelly. **CAVALIER'S BROIL**—A shoulder of mutton half cooked in the oven with a buttered paper over, scored down to the bone, seasonings put in the cuts; broiled upon the gridiron; served with pickled mushrooms. **MUTTON PIE**—Stewed meat well skimmed of fat, with onion, parsley, scooped potato balls and a top crust of good paste; baked an hour. **MUTTON CHOPS LIKE VENISON**—Chops without fat marinated in oil, vinegar, salt, pepper, onions, herbs; sautéed; served with game sauce. **MUTTON COLLOPS**—

## NAG

(1) Thin slices or steaks from the leg. (2) Scotch collops are minced; either mutton or beef. **CURRIED MUTTON**—Mutton in curry sauce; cold, cooked mutton will answer. **ROAST MUTTON AND LAVER**—“Most people know that a roast leg of four or five year old mutton (it were superfluous to expatiate upon the haunch) with laver *served in the saucepan*, is a dish of high merit, but it ought never to be profaned by the spit, which lets out the gravy, and shocks the sight with an unseemly perforation.”—**MUTTON SOUPS**—Scotch broth, hodge-podge, barley, *Piemontaise, Rouennaise, Grecque*, etc.

## N.

**NAGEOIRES** (Fr.)—Fins. **NAGEOIRES DE TORTUE**—Turtle fins or flippers.

**NAPERY**—Table linen. Really boiling water will remove most fruit stains from napery; but 1 oz. sal ammoniac and 1 oz. salt of tartar, in a quart of water, will extract them; also sherry or claret stains, if the linen be allowed to soak in the solution a short time.

**NAPKIN**—The law of the napkin is but vaguely understood. One of our esteemed metropolitan contemporaries informs an eager inquirer that it is bad to fold the napkin after dinner, that the proper thing is to throw it with negligent disregard on the table beside the plate, as to fold it would be a reflection on the host, and imply a familiarity that would not benefit an invited guest. But the thoughtful reader will agree with us that this studied disorder is likely to be a good deal more trying to a fastidious hostess than an unstudied replacing of the napkin in good order beside the visitor's plate. The proper thing is to fold the fabric with unostentatious care, and lay it on the left of the plate, far from the liquors, jiqueurs and coffee, and thus testify to the hostess that her care in preparing the table has been appreciated. The napkin has played famous parts in the fortunes of men and women. It was one of the points admired in Marie Stuart that, thanks to her exquisite breeding in the court of Marie de Medici, her tables were more imposing than the full court of her great rival and executioner, Elizabeth. At the table of the latter the rudest forms were maintained, the dishes were served on the table, and the great queen helped herself to the platter without fork or spoon, a page standing behind her with a silver ewer to bathe her fingers when the flesh had been torn from the roasts. At the court of the empire Eugenie was excessively fastidious. The use of a napkin and the manner of eating an egg made or ruined the career of a guest. The great critic, Saint Beuve, was disgraced and left off the visiting list because at a breakfast with the emperor and empress at the Tuilleries he carelessly opened his napkin and spread it over his knees and cut his egg in two in the middle. The court etiquette prescribed that the half folded napkin should lie on the left knee to be used in the least obtrusive manner in

## NIV

touching the lips, and the egg was to be merely broken on the larger end with the edge of the spoon and drained with its tip. The truth is, luxury and invention push table appliances so far that none can be expected to know the particular conventionality that may be considered good form in any diversified society. The way for a young fellow to do is to keep his eyes open—which unless he is in love, he can do—and note what others do.

**NAPLES BISCUITS**—Small sponge cakes.

**NAPOLITAINE** (Fr.)—Neapolitan; in Naples style.

**NAPOLITAINE, SAUCE**—Brown sauce containing port wine, horse-radish and currant jelly.

**NASTURTIUM**—Well known garden flower of low trailing habit; the green seeds are pickled as a substitute for capers.

**NATUREL** (Fr.)—Plain. **POMMES AU NATUREL**—Potatoes plain, either in the skins or without sauce.

**NAVARIN** (Fr.)—A brown mutton stew with assorted vegetables; the meat and vegetables both fried separately, first, then stewed together with water and thickened. The same as haricot of mutton.

**NAVET** (Fr.)—Turnip.

**NEAT**—English name for a calf. **NEAT'S FOOT OIL**—The oil from calve's feet, used for oiling machinery. **NEAT'S TONGUE**—Calf's tongue.

**NECTARINE**—The smooth-skinned peach. Not much cultivated in this country in comparison with the peach. Is cooked, preserved and pickled in all ways the same as peaches. The seeds are the flavoring ingredient in noyau liqueur.

**NEGUS**—Drink of wine and water. Named after a Col. Negus. Hot water is poured to sherry or port; sugar and slight flavoring.

**NELSON TART**—Mixture of almond paste, eggs, butter and flour richer than cake; baked in a crust.

**NESSELRODE PUDDING**—Kind of ice cream, made of purée of chestnuts, cream, candied fruits and flavorings. Named after a Russian statesman. Can be made by preparing a chestnut-custard rich with yolks and sugar, adding any kind of candied fruits or *marrons glacés*, and then an equal quantity thick cream whipped, and flavored with maraschino.

**NEUCHATEL CHEESE**—Soft kind of Swiss cheese; comes in form of rolls, wrapped in tinfoil. Is made in this country. Easily imitated by making cream-curd cheese in any dairy. Favorite variety with a great number of hotel patrons; gets better as it ripens, and ought to be kept in stock to give time to improve.

**NILSSON CUTLETS**—Cold dish of minced chicken in cutlet form, glazed all over and coated with chopped truffles and olives. Dished ornamentally in a circle with salad in the center.

**NIVERNAISE** (Fr.)—From *Nivernon*; a mix-

## NOE

ture of vegetables in gravy for garnish; nearly same as macedoine or jardiniere.

NOEL (Fr.)—Christmas. **POUDING DE NOEL**—Christmas pudding.

NOIR (Fr.)—Black. **CAFE NOIR**—Black or extra strong coffee. **BEURRE NOIR**—Fried butter, black or, rather, brown, used for sauce.

NOIX (Fr.)—A nut. **NOIX DE COCO**—Cocoanut. **NOIX DE VEAU**—The cushion-shaped piece of veal that is part of the round, next the flank, suitable from its shape for larding and glazing.

NOISETTE (Fr.)—A small nut; hazel nut; filbert; also, fillets of meat or fish.

NONNE (Fr.)—Nun. **NUN'S SIGHS** or **NUN'S SUPPERS** (*Soupers de Nonnes*)—Puff fritters, known as Spanish puffs.

NOODLES—American name for *nouilles*. Shreds of egg paste, sort of macaroni.

NOUGAT—Several varieties of candy. **ALMOND NOUGAT, BROWN**—Made by melting sugar by heat only, and stirring into it split almonds. **ALMOND NOUGAT, WHITE**—Sugar melted over the fire with the least possible amount of liquid, blanched almonds stirred in. **CORBELLES DE NOUGAT**—Baskets formed of either of the foregoing candies in their soft state while hot. **TROPHY DE NOUGAT**—



WHITE NOUGAT PYRAMID SUR SOCLE.

Ornamental sugar work on a decorated stand.

An ornamental design built up of either of the above in the soft state while hot, such as a hollow globe of brown nougat formed in a mould and supported by a figure of Atlas in cast candy. **TURKISH NOUGAT**—

## OIL

A soft candy in loaf form that can be cut like cheese; made of powdered sugar, honey, glucose, almonds, etc. **HONEY NOUGAT**—Another name for the preceding.

**NORFOLK DUMPLINGS**—Boiled light bread-dough. Pieces of the bread dough taken when light, made into balls, allowed to rise again, dropped into boiling water. Eaten either with meat or sweet sauce.

**NORWEGIAN PUDDINGS**—Cup-puddings or cakes served with wine sauce. Made of  $\frac{3}{4}$  lb. butter,  $\frac{3}{4}$  lb. sugar, 6 eggs,  $\frac{3}{4}$  lb. ground rice,  $\frac{1}{2}$  lb. flour, 2 teaspoons baking-powder, flavoring; mixed like cake, put in buttered cups; baked in slack oven, or steamed.

**NOUILLES** (Fr.)—A yellow paste made of flour wetted with yolk of egg only, rolled out thin as paper, cut in shreds for soups, or cut in leaves and fancy shapes to decorate pâtés and meat pies with; also for making raviolis, noques, etc. (*See Italian Cookery.*) Nouilles are cooked with cheese, or with butter, or tomatoes and gravy, in all the same ways as macaroni.

**NOUVELLES** (Fr.)—New. **POMMES NOUVELLES**—New potatoes.

**NOYAU**—A liqueur or cordial flavored with nectarine, bitter almond and peach kernels. **NOYAU CREAM**—Whipped cream flavored with noyau and set with gelatine. (*See Bavaroise.*)

**NUDELN** (Ger.)—Nouilles; noodles.

## O.

**OATMEAL**—An article of the first necessity now in every hotel; eaten both at breakfast and supper. The rolled oats are much easier to cook than coarse oatmeal. When the latter is used it needs to be soaked in water over night, then boiled 2 hours to make mush or porridge. It is eaten with cream or milk. "Oatmeal used to be the staple dietary article of our forefathers, but it is curious to note that while its sale has fallen off to a large extent in Scotland, it has latterly increased greatly in England. This is surely a silent revenge for Bannockburn. We have forgotten our national poet's line, 'The Galesome parritch, chief o' Scotia's food;' and England, which is 'annexing' every good thing that Scotland possesses, has now appropriated her porridge, while we poor Scotch are gradually deteriorating our race by the consumption of tea and white bread." **OATMEAL PUDDING WITH CREAM**—Made of 1 qt. boiling milk, 4 tablespoons oatmeal, 4 tablespoons flour, little salt. Oatmeal and flour stirred up with cold milk then poured into the boiling milk; cooked 20 minutes or longer; eaten with cream and sugar. **OAT CAKE**—Akron oatmeal with little butter rubbed in and salt, made into dough with hot water, rolled out thin and size of a dinner plate, cut in quarters, baked in oven.

**OIGNON** (Fr.)—Onion.

## OIL

**OIL, FRYING**—"There are two schools of cookery in France, as distinct from one another as the *langue d'Oil* is distinct from *langue d'Oc*. There is the kitchen of the North—and of Paris—in which butter is the principal vehicle; and there is the kitchen of the South—or Midi—in which oil is the chief assimilator; and the most trustworthy authorities on French gastronomy have always held that the *cuisine au beurre* was far more conducive to digestion than the *cuisine a l'huile*." Such is the theory deduced from cookery books but, in fact, butter is excessively dear in Paris and very little is used in cooking. The need of it is lessened by the employment of gravies and sauces instead, and for frying, oil, beef suet and lard are used. In the United States cotton seed oil is becoming the principal medium for frying. The cheapness of an article soon leads to a trial and adoption without regard to arguments. The cheapest grades of cotton seed oil give out an unpleasant smell and taste when heated but the better grades do not, it is but a question of quality and price; and much of the lard used by those who object to the oil is but the same oil in disguise. (*See Cotton Seed Oil Lard, Imitation Butter.*) The Jews who fry much fish use oil for frying, it is, or has been, neat's foot oil, but "vegetable oil" now takes the place of that. "Potato chips" and French fried potatoes are now advertised as being fried without the use of lard—meaning that oil is used. The hotel steward buys oil by the barrel and satisfies himself by previous trial of a small lot whether it is sufficiently refined for his purpose.

**OIL, SALAD**—Olive oil is obtained by crushing and pressing the olives in sacks, it is then subjected to refining processes. A vast quantity is produced yearly in the old countries and California is contributing largely to the supply, which she usually ships in cans; so it is not difficult, as is sometimes represented, to obtain real olive oil; but there is a likelihood that imitation oil being refined cotton oil, or pea-nut or both mixed, may be put upon the unwary purchaser at the price of pure olive. The best test is heating some of the oil in a frying pan, letting it become hot enough to smoke, then if the experimenter have had experience with low grades cotton oil, he will detect sufficient of the same smell in the refined article to apprise him that it is cotton oil still. Much cotton oil goes abroad in barrels and comes back in flasks labelled pure olive oil. The probability is in most cases it is a mixture of real olive with pea-nut oil and double-refined cotton seed. As only the thoroughly educated palate can detect the difference there is no particular harm in this but the making the consumer pay for a cheaper imitation the high price of the genuine article. Salad oil is one of the items of serious expense in hotels and restaurants and the subject is worthy of thought and attention.

**OKRA**—Well-known American vegetable, the seed pods of a plant like a hollyock which grows from 4 to 6 feet high. There are two varieties

## OLI

grown for market; the best bears the short, thick, green pods which remain tender longer than the other kind, which are long, pale green, slender and wiry. Few people, perhaps none, like the taste or appearance of cooked okra at first, but the liking grows so that no vegetable is more welcome to the people of the South than this, not excepting asparagus or peas. It cooks to a sort of mucilage, if prepared to the Creole taste, that is stewed in very little water. Where this is considered an objection it is cooked in plenty of water, salted, and the mucilage is not then so apparent. **STEWED OKRA**—The young and tender pods cut off at each end, washed, boiled in salted water about  $\frac{3}{4}$  hour, the water poured off; butter, pepper, little more salt mixed in by tipping up the vessel; okra served without breaking it in vegetable dishes. **OKRA A LA CREOLE**—The young pods trimmed, simmered in just enough water to cover with little salt, and buttered paper under the lid. When soft, a few spoonfuls olive oil and a minced red or green pepper shaken in; served as a vegetable. **STEWED OKRA WITH TOMATO SAUCE**—Tender pods trimmed and cooked nearly done in salt water with a slice of bacon, taken up and transferred to a saucepan containing tomato sauce and brown sauce mixed, with little butter. **STEWED OKRA AND TOMATOES**—Raw sliced tomatoes and okra sliced crosswise stewed together with seasonings; served as a vegetable like corn and tomatoes or succotash. **OKRA SOUPS**—Gumbo soups, and okra and tomato soups. **DRIED OKRA**—This sells in New York at about a dollar a pound at retail. It is evaporated in slices like apples, is used after soaking in that form, and is also ground to powder and used as *gumbo file*.

**OLIVE**—The fruit of the olive tree, formerly a special product of southern Europe, now the largest and best come from California. For hotel use olives should be bought by the keg, as glass packing, labels, etc., cost as much as the fruit. The majority of Americans are fond of olives and the demand is increasing. **OLIVES IN BRINE**—As bought in kegs and jars the olives are in salt water; they have been gathered green and steeped for a short time in lime water and lye, which counteracts the oil in them, and after that they will take up salt as well as cucumbers and are thus preserved. **TO PREVENT SOFTENING**—Olives must be kept under the brine, in the dark, covered up from the air, and never taken from the keg with the hands; nearly full kegs will sometimes turn soft and have to be thrown away through neglect of these precautions; the best package is the firkin-shaped bucket with a large bung in the lid; a wooden spoon can be used to dip them from the bung hole, which can then be tightly closed. **OLIVES WITH SALADS**—Besides the favorite method of eating olives raw, and salted as they are, they are valued as an addition and ornament to every sort of salad, and only a little less welcome when stoned and served in meat sauces. **EATING OLIVES**—There is etiquette in eating olives.



## OLI

Cardinal Richelieu is said to have detected an adventurer, who was passing himself off as a nobleman, by his helping himself to olives with a fork; it being *comme il faut* to use the fingers for that purpose. OLIVE PICKLES—Some people do not like olives as generally packed in brine. To such we recommend the soaking of the olives over night in fresh water, for which vinegar may afterwards be substituted. By this means the olives are converted into a nice pickle, and are very appetizing. OLIVE SAUCE—Olives in France are introduced in sauces for calves' head and fowls; and a duck is served with olive sauce. For these purposes the olives are turned with a knife, so as to take out the stone and leave the fruit whole. DUMAS' "HOW TO COOK AN OLIVE"—Place the olive inside an anchovy the anchovy inside a lark, the lark inside a quail, the quail inside a partridge, the partridge inside a pheasant, and the pheasant inside a turkey; roast the turkey until well done. Take the pheasant out of the turkey, the partridge out of the pheasant, the quail out of the partridge, the lark out of the quail, the anchovy out of the lark, and the olive out of the anchovy. The olive, imbued with the essential juices of all these toothsome viands, will, Dumas asserts, then be a *hors d'œuvre*, fit to set before a king.

OLIVES, MEAT—English name, without apparent reason, for thin slices of meat rolled up with forcemeat inside; thus there are "veal olive" pies, the rolls placed in order in a dish with gravy and a crust of paste, and many similar dishes.

OLLA PODRIDA—See *Spanish cookery*.

OMELET—Eggs slightly beaten, cooked like a pancake in a frying pan, rolled or half turned. There is an important little secret in making these delicacies. A very clean frying pan is of course indispensable, and after having placed about an ounce of fresh butter to melt in the frying-pan, *the oiled butter should be poured into the omelette mixture*, and thoroughly whisked into it. This will not only prevent the omelet sticking to the pan, but will give it a richness not otherwise obtainable. OMELETTE AUX ROGNONS—Specialty. "Well, now, try this: Stew the kidneys, add seasoning, a pinch of cayenne (or, better still, a small whole capsicum-pod), and an apple or two. When done, strain off; chop the kidneys fine; make a savory omelette; rub the apples through a tammy, and add them to the gravy; thicken it, and put it in the bottom of a scalding-hot dish; place the kidneys in the omelette, and let the latter *almost* float in the gravy, (or sauce) and serve. Ye gods! what a feast!" OMELETTE WITH SPINACH—Spinach boiled, drained, chopped fine, seasoned with little onion fried in butter. A savory omelet made and served in hot dish with the spinach around it. ASPARAGUS OMELET—Green points of asparagus boiled, drained, seasoned, mixed in an omelet and cooked in it. PARSLEY OMELET—Three eggs, tablespoonful of cream and same of chopped

## OME

parsley, slightly beaten together; cooked on one side, salted, rolled up. KIDNEY OMELET—Mutton kidneys thinly sliced, fried, and sauce made to them with wine. A savory omelet made and kidneys inclosed in it, with the thick sauce. TOMATO OMELET—Onion fried in butter, and tomatoes added and dried down, seasoned. Omelet made, cooked on one side and tomatoes inclosed in it. OMELETTE A LA MINUTE—"Before an English cook would have fairly smashed her eggs, a French *chef* has whisked them, tossed in a pinch of salt and chopped parsley, shaken all over a roaring coke fire as if he was seized with sudden frenzy, and plumped his omelet into a dish cooked to a turn. The Granville Hotel has a *chef* who is great at that triumph of the art culinaire—an omelet. Especially does he excel with shrimp and truffle omelets." OMELETTE A LA JARDINIÈRE—Mixed vegetables comprising mushrooms, carrots, turnips, beans, peas, cooked in stock with herbs; brown sauce and thickening added. Half the vegetables mixed in an omelet, rest poured over when done. OMELETTE AU NATUREL—Plain omelet. OMELETTE AUX HUITRES—Oyster omelet. OMELETTE AUX OLIVES—Omelet with chopped olives and brown sauce. OMELETTE AUX CHAMPIGNONS—Mushroom omelet. OMELETTE AU PARMESAN—With grated Parmesan cheese. OMELETTE AU FROMAGE—Cheese omelet. OMELETTE AU JAMBON—Ham omelet. OMELETTE AU LARD—Bacon omelet. OMELETTE A LA PUREE DE VOLAILLE—Purée of chicken in cream rolled up in the omelet. OMELETTE AUX TRUFFES—Sliced truffles in brown sauce in the center of the omelet. OMELETTE AUX EPINARDS—Spinach omelet, green color, the purée of spinach mixed with the eggs before cooking. OMELETTE AUX FINES HERBES—Mixture of shallots, mushrooms and parsley lightly fried, mixed in the omelet before cooking. OMELETTE A L'ALGERIENNE—Rice boiled, seasoned with butter and tomato sauce, spread inside an omelet; served with tomato sauce. OMELETTE A L'INDIENNE—Onion lightly fried in oil, with curry powder and cream mixed in the omelet before cooking. Boiled and seasoned rice spread on the omelet and folded up in it; served with curry sauce. SAVORY SOUFFLE—Light omelet made by separating the yolks and whites, yolks beaten with little cream and seasonings, whites whipped firm and added; cooked by stirring in the omelet pan and finish in the oven. SPANISH OMELET—Tomatoes, chopped ham, green pepper and onions fried together, placed part inside and rest around the omelet. OMELETTE A LA PROVENCALE—Onion omelet with little garlic, the onions and garlic lightly fried first, rolled up in the omelet. TRAVELERS' OMELET—Cold, substitute for sandwiches. Omelet like a pancake, spread with potted ham or tongue and mustard. SPORTSMAN'S OMELET—With purée of game inside and hot *fumet* of game sauce. OMELETTE A LA MILANAISE—Macaroni and cheese in tomato sauce inside an omelet, cheese sifted over outside while hot enough

## ONI

to partly melt it; sauce. OMELETTE AUX CONFITURES—Sweet omelet soufflée with marmalade in the baking dish under it, baked, sugared over top. OMELETTE A LA CLAREMONT—Sweet egg pancake with apple marmalade inside, sugared over and glazed. OMELETTE A LA CELESTINE—Omelet with frangipane pastry cream inside, apricot jam diluted with kirschwasser poured over. OMELETTE AU CHOCOLATE—Soufflée made by adding dissolved chocolate in warm cream to yolks, the whites whipped and added; cooked partly in omelet pan on fire, finished in the oven. MERINGUED OMELET—Omelet rolled up with jam inside, meringued over and browned. OMELETTE AU RHUM—Rum omelet. Omelet with little sugar and cream in it and spoonful of rum; when turned on dish sugared over, marked in stripes with red-hot wire on the sugar, warm rum poured around and set on fire. OMELETTE SOUFFLE—Puff omelet, sweet and flavored; made with 1 teaspoon sugar to each egg, yolks and whites whipped separately, with sugar and teaspoonful milk with the yolks; all stirred together, baked in dish or in frying pan partly on top and finished in oven. Sugar sifted over and should be glazed with red-hot shovel or iron. Omelettes soufflées are made almost as various as ice creams, with different flavorings and mixtures of pistachios, almonds, etc. (*See Eggs.*)

ONION—"We give the name of onion to all the plants of the onion tribe. The leek is to us an onion, and so is garlic and the shallot. In old English the leek was the type, and garlic was but a gar-leek—a spear-headed leek. In the language of science, garlic is made the standard, and the onion is but a species of allium or garlic. It may be taken for granted that of all the flavoring substances used in cookery, the onion is, after salt, the most valuable; and cunningly concealed in a sauce, in a stew, or in a soup, it yields enjoyment even to those who would carefully put it from them if they saw it." "A famous epicure once said that two things were absolutely indispensable to a good dinner and without either of them the cook's art is lost. He meant the onion and the truffle. For the truffle in recent years several substitutes have been found, but the onion still holds its own unrivaled as the essence of all dishes that are prized because of their flavor. The onion is the sheet anchor of the skillful cook. It is impossible to prepare the delicate Bordelaise sauce without resorting to the use of onions and a shade of garlic. This may surprise many of those who detest the very mention of the onion, but it is nevertheless a fact, and it is the judicious use of these two seasonings that stamps the expert cook." ONIONS FOR HEALTH—"Another writer, advocating their use, says: During unhealthy seasons, when diphtheria and like contagious diseases prevail, onions ought to be eaten raw at least once a week. Onions are invigorating, prophylactic beyond description." ONIONS FOR A COLD—"For a cold on the chest there is no better specific, for most persons,

## ORA

than well boiled or roasted onions." ONIONS A LA CREME—Onions boiled in salted water, drained, put in cream sauce. STEWED ONIONS—Cut in quarters, boiled in salted water, drained, and put into butter sauce or cream sauce. FRIED ONIONS—(1) Sliced in a frying pan and sautéed till partly brown and all tender, fat drained off, seasoned. (2) Cut in rings, fried in kettle of hot lard like fried potatoes, drained, salted. BAKED ONIONS—Parboiled, drained, placed in baking pan with butter, little sugar and water, salt; basted while baking till brown, and glazed. OIGNONS AU JUS—Boiled onions with meat gravy. OIGNONS FARCIS—Centers cut out, stuffed, baked. OIGNONS A LA POULETTE—Button onions in yellow sauce thickened with yolks. PUREE D'OIGNONS A LA BRETONNE—Onions mashed through a strainer, simmered with meat glaze, served with fried bread in shapes. ONION SAUCES—Soubise sauce both white and brown, Bretonne, etc. (*See Sauces.*)—ONION SOUPS—Cream of onions, purée of onions, Soubise, etc. (*See Soups.*)

OPPOSSUM—American country luxury. The 'possum is like a young pig; its skin is cooked with it the same way, being freed from the hair by scalding and scraping. The famous Southern native dish of 'POSSUM AND SWEET POTATOES has the 'possum split open, surrounded with potatoes cut lengthwise, all baked in a pan together with salt, pepper and lard or fat of some kind. Served with corn bread. This animal is hunted with dogs; is found in hollow trees.

ORANGE—HOW TO EAT AN ORANGE—In Florida, and many other parts of the country, the orange is cut in halves and its juice and pulp are passed to the mouth with a teaspoon. In Havana the orange is served whole on the table, peeled down to the juicy "meat" of the fruit, and you present the golden ball to your lips on the prongs of a fork. HOW TO SERVE ORANGES—The best hotel plan of serving is this: the waiter with the point of a penknife divides the peel only, in four quarters without quite severing them at the bottom, then removes the peel from the orange which he further pares of its white coat; he then puts the orange back in its peel which is like four leaves to a flower, and so presents it to the guests. Another way is to peel the oranges, divesting them as much as possible of the white inside rind as well, and pile them on a folded napkin in the fruit basket or compotiere. A method in advance of that for a family table or party at one table, is to take, say, 4 or 6 oranges, peel them carefully, removing all the rind; then pull the natural sections half apart, dividing them about half way; stick a clove in the top point of each section; bunch all the oranges together on a handsomely folded napkin in a compotiere, and with the loosened sections slightly spreading outwards the whole looks like one, like some novel sort of fruit or flower, and the further separation is easily accomplished with a teaspoon. TO PREPARE AN ORANGE FOR EATING—"Joseph gave me a sample of his work at my house.

## ORA

He sent my servant out for two oranges and a bunch of violets. He took the orange and cut it with his penknife so as to resemble a basket, deftly extracted the fruit, cut out all the eatable part, replaced it in the basket, poured the wasted juice over this, added kirsch and sugar. Then with a sharp penknife he cut a longitudinal slit in the handle of the basket, and inserted the violets in this, making of the orange-basket an *entremet*, pretty enough to be served on any table. Whilst performing this feat of culinary *legerdemain* (for it was done so deftly and expeditiously that it really was *legerdemain*), he called my attention to the fact that he never once touched the fruit with his hands." BUY A GROVE—"An orange tree will bear fruit until it arrives at the age of 150 years, and there are instances recorded of orange trees bearing when 500 years old. In Malta and Naples, 15,000 oranges have been picked from a single tree; and there is one noted tree in the Sandwich Islands that has been estimated to bear 20,000 in one season. ORANGE HONEY—Yellow jam made of 3 oranges, 1 lemon, 1 lb. sugar,  $\frac{1}{4}$  lb. butter, 8 yolks, 1 egg; sugar juice and grated rinds boiled together, butter and eggs added; simmered. Like honey, for filling mirletons, fanchonettes, cheese-cakes, darioles, talmouses, turnovers, tarts, jelly cakes. TANGERINE JELLY—Made of  $\frac{3}{4}$  lb. sugar, 1 oz. gelatine, juice of 15 Tangerine oranges, 2 sour oranges, 1 lemon, peel of 1 orange; gelatine dissolved in hot water, sugar, peel, juice added, strained; to make 3 pints by adding water; set in moulds. ORANGE MARMALADE—Oranges peeled, the peel boiled 3 or 4 hours, in 3 or 4 waters, till quite tender and bitterness all extracted; then shred as fine as hay; to every dozen oranges allowed 4 lemons, and juice of all squeezed into kettle, and  $\frac{1}{4}$  as much water besides; to each pint of juice  $1\frac{1}{2}$  lbs. sugar, the peel added; all boiled till thick enough to keep. COMPOTE OF ORANGES—(1) Oranges divided in sections [peeled]; to 8 oranges 1 lb. sugar,  $\frac{1}{2}$  cup water, rind of 1 orange; boiled to make syrup; when a little cool poured over the oranges; eaten cold. (2) Oranges divested of peel and rind, boiled, without dividing, in 2 waters for  $\frac{1}{2}$  hour, then boiled in syrup; peel boiled longer in 3 waters, then shredded and boiled in syrup; served on top of the oranges; cold like a preserve. ORANGES A LA DEMIDOFF—Like compote No. 1, with maraschino in the syrup. ORANGES A LA PORTUGAISE—Orange skins emptied with a teaspoon, filled with orange ice and fruits, served frozen. CROUTES AUX ORANGES—Quarters of oranges boiled a few minutes in syrup, served on thin shapes of bread fried in butter. ORANGE FRITTERS—Peeled and quartered oranges scalded in boiling syrup, drained, dipped in batter, fried; sauce or powdered sugar. ORANGE JELLY—Sugar, water and gelatine boiled with white of egg and strained; orange rind added to it warm; orange juice filtered separately and added; all strained into mould and set on ice. (See *Jellies*.) ORANGES FILLED WITH JELLY—Orange skins emptied with teaspoon, filled with jellies

## ORA

of two or more colors, set on ice, cut, and colors arranged alternately to serve. ORANGE ICE—Sugar-syrup, glucose, orange peel steeped, and orange juice; frozen. CROQUEMBOUCHE OF ORANGES—Sugar boiled to the crack, pared sections of oranges dipped in and placed in order while hot in a mould; the casing becomes candy when cold, and the form is turned out. FLAN D'ORANGES—An open pie filled with stewed oranges, custard on top. POU<sup>d</sup> DINGS AUX ORANGES—Orange puddings of as many sorts as lemon puddings, either orange bread-puddings, oranges and rice, or tapioca, or starch, orange custard, etc. BEIGNETS D'ORANGES—Orange fritters. CREME D'ORANGES—Orange cream. GLACE CREME D'ORANGES—Orange ice-cream. ORANGE SAUCE FOR DUCKS—See *Bigarade*. ORANGE PIES—Made as lemon pies in three or more ways. (See *Lemons*.) ORANGE PUDDING—Specialty. Made of 2 stale small sponge cakes, 4 oranges, 3 oz. sugar, 1 oz. butter, 3 eggs, 1 cup milk; boiling milk to sponge cakes, little grated orange rind, all the juice and other ingredients; baked. CHARTREUSE OF ORANGES—Oranges not peeled, cut in slices shape of the natural sections, dipped in strong orange jelly, placed around a mould set in ice; when set, filled up with any sort of jelly, or Bavarian, or ice cream. ORANGE SNOW—Orange jelly with whipped whites stirred in when about to set, and all whipped up white; set in moulds. GELEE MOUSSEUSE A L'ORANGE—French name of orange snow above. ORANGE SALAD—Sweet; made of 6 oranges,  $\frac{1}{4}$  lb. raisins, 2 oz. sugar, brandy or wine; 5 of the oranges peeled and in sections, raisins cut and stoned, soaked in sugar and brandy and mixed in, juice of other orange squeezed over. (See *Ambrosia*.) ORANGES WITH STRAWBERRIES—"Nothing can surpass the method of eating strawberries with cream. The combination is not only delicious in itself, but carries with it the happiest remembrances of rural life and childish innocence. But cream is not always to be had, and some people are afraid of it. The Spaniards have another noble combination, moistening the strawberries with the juice of a sweet orange. There are gastrologers who go further, and say that an addition of orange peel (by grating the zest with a lump of sugar) is an immense improvement; and that it must have been in this fashion the fruit was served in the banquets of Mount Ida." KINDS OF ORANGES—It is said that about 100 varieties of oranges are known in Italy. "Blood" oranges, as they are called, come mostly from Valencia, but a few from Malta. The aromatic and delicious Tangerines hail from St. Michael's, and also from Lisbon, and varies considerably in price, according to supply. Seville oranges come from the place of that name, and, as most people know, are now almost exclusively used for making marmalade and orange wine." CANNING ORANGES—"Oranges have recently been successfully canned. The fruit is peeled and broken into its natural sections before canning, and when taken out is just ready for use. This is

## ORC

likely to become an important industry in the orange-growing districts of California and Florida." **ORANGE TRIFLE**—Peeled oranges sliced in a dish, sugar over, another layer and sugar, boiled custard poured to the oranges warm, egg whites or cream (whipped) on top when cold; served with cake. **ORANGEADE**—Like lemonade. **ORANGE WINE**—Sugar syrup boiled, orange juice added to it, fermented with yeast 3 or 4 days, bunged tight; bottled after 6 months with little brandy added in the bottles.

**ORCHINET ROOT**—A coloring ingredient to be bought at drug stores, used to make red butter for coloring cardinal sauce, etc.

**OREILLES (Fr.)**—Ears. **OREILLES DE VEAU AUX CHAMPIGNONS**—Calves' ears with mushrooms. **OREILLES D'AGNEAU FARCIES**—Lambs' ears stuffed, breaded and fried. **OREILLES DE PORC A LA STE. MENEHOULD**—Pigs' ears breaded and baked, served with remoulade sauce. **OREILLES DE PORC BRAISEES**—Pigs' ears braised in stock, served on spinach. **OREILLES DE PORC A LA LYONNAISE**—Cut in strips in brown onion sauce.

**ORGEAT**—Almond syrup or milk of almonds. It is made with milk for orgeat ice-cream. "And now a tip to you, ladies and gentlemen, how to make *orgeat* as the Frenchman likes it, and probably often asks you for it. Take 2½ lbs. of bitter almonds, 1 lb. 1 oz. of sweet almonds, 20 lbs. of white sugar, 9 pts. of water, the peel of 3 lemons, and 12 drops of essence of neroli. Throw the almonds into boiling water, leave them for 10 minutes, then place them in cold water and remove their skins; then pestle them up with the sugar, and, after adding the 9 pts. of water and the lemon peel, let them boil a minute or two, and finally pass the decoction through a sieve, taking care to press out all the milk in the almonds. Orgeat is usually drunk with cold water (half-and-half), with a dash of rum in it. It makes a most wholesome and refreshing summer-drink."

**ORIENTAL COOKERY**—**TURKISH DINNER**—"Silence and expedition are the chief characteristics of a Turkish meal. The table preparations are few, but the dishes are many; olives, caviare, cheese, etc., are dotted about, and perhaps as many as ten dishes are handed round on covered brazen dishes consisting of rice or barley, meat or boiled fish, cakes seasoned with vegetables, roast lamb, beans, a species of rissole wrapped up in vine leaves, the inevitable pilaf and fruits, and, as wine is forbidden, an intoxicating substitute is found in liquors and brandy. Each person has his glass of sherbet by him, and his piece of unleavened bread, for the Turks love half-baked dough. It will comfort the European to see every one wash his hands before his meal, for forks are unknown, and each is expected to dip his fingers into the savory morsel as it is handed to him. During the whole of the feeding process scarcely four or five words will be uttered, and at the most your repast will last 20 minutes; but then afterward, with the coffee and the hubble-bubble, conversation will

## ORI

flow freely. To the Turk eating is a serious gastro-nomic exercise, which will not admit of any conversation being entered into during the process."—**TURKISH BREAKFAST**—"A Turkish breakfast comprises about thirty dishes. Soon after the first dish comes lamb, roasted on the spit, which must never be wanting at any Turkish banquet. Then follow dishes of solid and liquid, sour and sweet, in the order of which a certain kind of recurring change is observed to keep the appetite alive. The pilau of boiled rice is always the concluding dish. The externals to such a feast as this are these: A great round plate of metal with a plain edge, of three feet in diameter, is placed on a low frame, and serves as a table, at which five or six people can repose on rugs. The legs are hidden in the extensive folds which encircle the body. The left hand must remain invisible; it would be improper to expose it in any way while eating. The right hand is permitted alone to be active. There are no plates, or knives, or forks. The table is decked with dishes, deep and shallow, covered and uncovered. These are continually being changed, so that little can be eaten from each. Some remain longer, as roast meat, cold milk, and gherkins, and are often recurred to. Before and after dinner they wash their hands. An attendant or slave kneels, with a metal basin in hand and a piece of soap on a little saucer in the other. Water is poured by him over the hands of the washer from a metal jug; over his arm hangs an elegantly embroidered napkin for drying the hands upon." **THE TURKISH KEBAB**—The Turk of to-day usually declines pork, but will not scruple to use veal. He eats beef very rarely; he indulges in ducks, lean fowls, and sheep and lamb, the flesh of which is cut in small pieces. These pieces are strung upon long spits, which are held and turned for some minutes over hot coals, where they are slowly roasted, retaining all their juices. This is what is termed *kebab*, a healthful and nutritious food which all Europeans and Americans find delicious. The lists of Turkish dishes show no less than sixteen ordinary *kebabs*. (*See Kabob.*) **SUT KEBABI**—Pieces of the loin of mutton or lamb about the size of a guinea egg sprinkled with salt, pepper, and ground cinnamon, allowed to absorb the seasonings for 2 hours. Par-boiled in milk, taken out, ran upon skewers, and roasted, basted with milk and flour until brown. Dusted with cinnamon; served hot. **KIYMADAN FIRIN KEBABI**—Baked mincemeat *kebab*, made of minced raw mutton, and minced onions partly fried in butter, with pistachio nuts, currants, salt, pepper and cinnamon. A caul fat is cut in pieces, the mincemeat in small portions wrapped in the pieces and baked. **TURKISH SAUSAGES**—Raw mutton minced, and raw rice mixed, with salt, pepper, cinnamon and milk. Stuffed into sausage skins, boiled a short time in salted water. When cold, fried in butter, or breaded and fried. **TURKISH DOLMADES**—Beef minced with raw rice, onion, parsley, pepper, salt, butter; some vine leaves parboiled, portions of

## ORI

sausage meat inclosed in the leaves, stewed slowly with water and butter in a covered saucepan; served with egg and lemon sauce. **SOUVALAKIAS**—Minced beef balls, like German *klöse*, made of  $\frac{1}{2}$  lb. each minced beef and bread panada and  $\frac{1}{4}$  lb. suet, flavored with onion, made into quenelles very small, rolled in flour, cooked in light wine sauce an hour; served with mushrooms and stuffed olives. **PILAF**—Rice boiled in broth, variously seasoned, nearly the same as Italian *risotto*. May have tomato sauce and butter. A traveller says: "In the villages, however, the inevitable dishes are pilaf and yaort. The former dish is found almost all over Mahomedan Asia. With a foundation of rice or wheat it receives a variety of other compounds, from chopped mutton to sweet almonds and raisins, and sometimes wild herbs. Yaort is a preparation of clabbered milk, prepared so that it will keep for a long time. **BEIGNETS DU HAREM**—Rice dough made of cooked rice, flour, yeast and little salt, balls size of pigeon's eggs taken off when it is light, and fried same as doughnuts. They are quite white. Dusted with sugar and served with raspberry sauce. **TURKISH SWEETS**—The Turks are celebrated for the variety and excellence of their pastry and sweets. **SOUFFLES A LA SKILIZI**—Vanilla sponge cakes moistened with kirschwasser syrup, made hot and served with sauce. **RAHAT LAKOUM**—"The *rahat lakoum* (coagulated delight) of the Turks is a preparation of *pecten* (the base imitation sold in this country is flavored gelatine.) I fed upon it once in the kitchen of the Seraglio at Constantinople. It was specially prepared for the Sultanas, and presented to me by his Excellency the Grand Confectioner as a sample of his masterpiece. Although more than forty years have elapsed since that moment of delight, the remembrance has not yet faded from my dreams. The flavoring essences of the grape, the nectarine, the pineapple, and I know not what other fruits, were there with all their aromas unpolluted. The sherbet was similar, but liquid. Well may the Turk abstain from the gross concoction that we call wine when such ambrosial nectar takes its place."—**RAHAT-IL-HOLKUM**—Rahat Lakoum; otherwise familiarly known in this country as "Turkish Delight." Is made of 3 lbs. loaf sugar, 4 qts. water, boiled, 9 oz. starch added, boiled with constant stirring until thick. Pieces dropped in powdered sugar will not moisten or absorb the sugar when it has boiled enough. To be flavored with musk the size of a pea, dissolved in rose water. Poured out in oiled pan, cut in pieces when cold. (*See Fig Paste and Gum Drops.*) **EKMEK KADAYIFI**—Make a syrup of 1 lb. sugar and 2 pts. of water. Cut open 4 or 5 muffins and soak them in the syrup for 2 or 3 minutes. Remove with a slice, and place half of them in a baking-tin; sprinkle over with pounded almonds or pistachios, then a layer of clotted cream  $\frac{1}{4}$  in. thick, more almonds, and then the remaining halves of the muffins. Now pour  $\frac{3}{4}$  of a pint of the syrup over, place in the oven, or on a moderate

## ORI

charcoal fire, until the syrup is nearly all absorbed, and serve either hot or cold. **AADI BAKLAWA**—Balaklava cakes. Paste like nouilles paste rolled out thin as paper, piled on each other with almond paste between some layers, butter poured over, baked in deep pan, honey syrup poured over, cut in pieces to serve. **ROSE JAM**—Many tons' weight of rose leaves, gathered and packed while they are freshly fallen, are converted into rose jam, one of the exquisite conserves which under the generic name of *dulchatz*, are so admirably confectioned in Turkey, Greece, and Roumania, and constitute a leading feature in the toothsome refection offered to the casual visitor in every well-to-do oriental household. Rose jam, considered as a sweetmeat, is far superior in flavor and savor to *Rahat Lakoum*, and to the somewhat cloying preparations of angelica for which certain Stamboul confectioners are justly famous. It is by no means sickly, or even insipid, as those delicacies unquestionably are, but is characterized by an after taste no less brisk and refreshing than that of the black cherry *dulchatz*, paragon of all Turkish sweets. **ARAB GASTRONOMY**—The silk-clad merchants one encounters in the bazars of Damascus and Bagdad are capital judges of a good dinner. If western *gourmets* are ignorant of the *haute cuisine* of the Arabs it is owing to the circumstance that invitations to dinner are rarely given to strangers, whom true believers regard as unclean. In a vague way it is understood that *kebabs* and *pilau* are not reckoned as high-class cookery among the natives. Some few, perhaps, have heard or read of the much esteemed *Samytah*, a purée of cream, dates, and starch; the *Therid*, a soup of olive oil, vinegar, eggs and bread; the tasty *Sikbaj*, or beef stew; and the golden *Judabah*, sugared rice swimming in chicken fat. But the dainty dishes of the Arab epicure, the appetite-enticing *wast*, the delicious *sanbusaj*, the leafy *qutais*, and the honeyed *luzinyeh*, are dainties of which the outer infidel world knows nothing. **SIKBAJ**—A stew of sheep's heads. This is esteemed one of the greatest triumphs of cookery and the test of a cook's excellence. The heads are scraped, the ears left on and filled with flavored forcemeat; they are then braised and served with a sauce of olive oil and vinegar. More than one good Moslem owes his death to a surfeit of this dainty. Another esteemed preparation is **QARID**—A fish stew. The fish is chopped and gently stewed in butter, balls of minced liver and vegetables are thrown in, and the whole taken to table with a sauce made of vinegar, capers, mustard, rue, cumin and celery. Tongues, livers and roes of rare and expensive fish are added to enhance the flavor and cost of this dainty. **WAST**—A species of sandwich which is supposed to sharpen the appetite. Slices of bread are spread with white chicken meat, grape syrup is poured round it, and the surface is spread with almonds, olives, cheese, and chopped eggs. *Wast* comes, according to the Arab usages, immediately after such light entrées as

## ORI

*tardynah* and *sanbusaj*. The latter is a cross between a ragout and a patty, being one of the choicest delicacies known to eastern epicures. Esahaq, a famous oracle of the kitchen, bequeathed to his countrymen the recipe for *sanbusaj*. It is a timbale filled with a paste of pounded cabbage, meat, fat, onions and spices. TURKISH SAUSAGES—The intestines of sheep filled with a composition of rice-flour, chopped meat, and almonds, and formed into a kind of knotted tripe, are also much esteemed by Arab gourmands; and it may take a little of the conceit out of Scotchmen who regard haggis as a special product of Caledonia, to learn that it is an immemorial delicacy of the East. ARAB SWEETS—In the shape of sweets (of which, as everyone knows, all Orientals are mordinately fond), there are two confections which grace every gourmand's dinner table. They are the *luzinyeh*, or almond cakes, "distilling tears of sugar and butter," and *qutaif*, or pancakes. These are served, as in the West, towards the end of the dinner, after a course of "appetizers." ARAB HORS D'ŒUVRES—Such as sharp cheese, spiced vinegar, red eggs and olives, pickled fish and asparagus in oil. LUZINYEH—Same as the Balaklava cakes of the Turks and Greeks. The *luzinyeh* consists of thin shells of pastry—the thinness of the dough being the point upon which epicures insist—containing a rich stuffing of almonds and sweet flavoring. They are served swimming in a sauce of melted butter and honey. For a thousand years they have been deemed one of the greatest delicacies of the kitchen. Ahmed Ibn Yahye says of them:

"Appetite cannot so close its portals  
But the approach of this dish unlocks them."

For all that, *qutaif* (the *ekmek kataif* of the Turks) runs the *luzinyeh* very close. The *qutaif*, or pancakes, are thin and leafy, fried in almond oil; and are served up humid with "the oil ozing from them" and a rich syrup "in which they sink and swim," and covered with rose-water. Cold water is not greatly in request among eastern lovers of good cheer. The beverage of the Arab epicure is *dushab*, a mixture of *nebidh* (date-water) and *dibs* (wine juice reduced to a very thick and luscious syrup). From time immemorial this has been the favorite drink of the Bagdad gourmands. PERSIAN FARE—"One of the most interesting Oriental meals I remember taking was with Ali Khan, the Governor of Khoi, a city of western Persia. The dinner was served on a cloth spread on the floor. The Governor and his councillors, grave and dignified old Persians in flowing silk gowns and henna-stained beards, squatted cross-legged around the edge of the cloth. Heaping dishes of rice pilaf, some dyed crimson and some yellow, occupied the center, heaps of flat, thin sheets of bread, boiled mutton, *bayaar kabobs*, pastry of sweetened rice-flour, melons, fruit and bowls of iced sherbet. Each Persian had one of the thin sheets of bread spread out before him for a plate; bending over these they scooped up small

## ORN

handfuls of *pilaf* from the nearest dish, and, rolling it into sizable balls, tossed them dexterously into their mouths. An act of courtesy would be to ferret out some dainty tit-bit of mutton from the dish and place it on one's next neighbor's sheet of bread. No knife, nor fork, nor spoon, nor implement of any kind, was on the table beside the dishes save a porcelain ladle to fill glasses with sherbet from the bowl. The thin, pliable sheets of bread were used to wipe the finger-tips after handling the greasy mutton, and occasionally a small piece would be torn off and eaten." HOW THE ARABS CARVE—The Arabs know how to carve a fowl without having the bird migrate all over the table and finally land in the lap of one of the diners. Five Arabs seat themselves around a large bowl of rice surmounted by a fowl. Two seize the wings with their fingers and two the legs, and simultaneously tearing these off leave the carcass to the fifth. It is probable that they draw lots for the honor of being the fifth. It must be a bad omen to have six men at the table when a fowl is carved in this fashion—that is, bad for the sixth man if he is fond of fowl.

ORMERS—Specialty. Shell-fish found on the Florida as well as the French coasts. "Wot you of ormers, a shell-fish, known popularly as 'Venus' ears,' from the shape and mother-of-pearl beauty of them? They are only to be found at very low tides, and are out of season from June to September. Choose those of medium size, lay them in salt and water, beat them well, add season according to taste. Stew for 2 hours in Béchamel sauce—if preferred in brown sauce, dip first in flour; if fried, dip in flour. They are extremely good curried, but they always require a long time to cook. The flavor resembles something dainty, between very delicate veal and Ai oysters. I will stake my reputation as a *gourmet* on this dish."

## ORNAMENTED CAKE—



See *Icing Cakes, Icing Tubes, Gum Paste.*

ORONGE—A sort of large, flat, orange colored and delicious mushroom which grows on the bark of trees, very abundant in southern Europe. Is put up in cans in oil, like *cepes*. ORONGES A LA BORDE-

## ORT

LAISE—Same way as *cefes*, which see. URBAIN DU-BOIS' FIRST TASTE—"As I looked around I observed a large open basket full of mushrooms of a peculiar kind quite unknown to me. I was taking stock of the contents of his basket, when the boy, noticing my curiosity, asked me to taste his merchandise. 'What do you call this?' I asked. 'Cocons,' answered the boy. I was not much the wiser, so I put further questions to the lad, who explained to me that these 'cocons' were young unopened oranges. 'How do you eat them in this country?' said I. 'Oh, it is very simple.' Then taking one of the cocons he wiped it well with a piece of paper, broke it in two, gave a hearty bite to one of the pieces, and handed me the other half, saying: 'Taste it sir; do as I do.' Without hesitation I followed his example. 'You are right,' said I to the young man, 'it is more than good, it is excellent.' And I bought the whole of the contents of his basket." (*See Salads, Savoie.*)

ORTOLAN—A famous luxury of ancient and modern epicures, concerning which there are more stories of reckless expenditure and extravagance told than of any other rare dainty whatever not excepting even the truffle. The ortolan is a small bird comparable to the rice bird of America; its home is Italy, France and southern Europe generally. The scarcity of the bird as compared with the demand gives it prominence as a most expensive morsel.—ORTOLANS AMONG THE ROMANS—Soyer says: "Florence and Bologna sent to Rome cases of ortolans, the enormous price of which irritated instead of discouraging gluttony. They arrived in the metropolis of the world, picked and separated one from the other by layers of flour to prevent decomposition. Each of these little birds furnish only a mouthful; but this incomparable mouthful eclipsed everything else, and produced a sort of epicurean ecstasy which may be called the *transcendentalism* of gastronomy." ORTOLANS AND QUAILS—"At this time of year the caterer must perforce meet the appetite of his epicurean customers for 'winged game' by placing on *menu* ortolans and quails. The former delicious little birds—'lumps of delight,' as some enthusiastic *gourmet* has described them—are too expensive for ordinary diners, and the quail is the only really popular game substitute." HOW TO KILL AN ORTOLAN—"Ortolans should not be killed with violence, like other birds, as this might crush and bruise the delicate flesh—to avoid which the usual mode is to plunge the head of the ortolan into a glass of brandy." ORTOLANS BROILED IN CASES—"Having picked the bird of its feathers, singe it, cut off the beak and ends of the feet, but do not draw it; put it into a paper case soaked in olive-oil, and broil it over a slow fire—charcoal or slack cinders—and in a few minutes the ortolan will swim in its own fat and be cooked. Some epicures wrap each bird in a vine leaf." ORTOLANS A LA ROYALE—"One of the dishes for the supper-table, upon the occasion of a grand ball given by Sir Julian Goldsmid on the 15th of June last. Everything was carried out upon the

## OXF

most magnificent scale; the table decorations were elaborate and beautiful, and the service was all in gold!"—"Bone the ortolans; fill them with a purée of *foie gras* incorporated with a little chicken force-meat. Next roll each bird in a leaf of buttered paper, and poach them in an oven. When cold, the paper should be removed, each ortolan carefully trimmed, and the whole covered neatly with a brown chaud-froid sauce, flavored with an extract prepared from bones of the birds." ORTOLANS ROASTED—The birds trussed without drawing them. First a vine-leaf and then a slice of bacon laid over the breast of each and tied on with a string. Roasted at quick fire in about 25 minutes; served on toast with their own gravy, and orange sauce aside. ORTOLANS IN TRUFFLES—Large truffles with part of the inside removed and an ortolan placed inside; in a saucepan with slices of bacon, and wine, etc.; served in the truffles on toast, with sauce made of the essence in the saucepan. ORTOLANS A LA PERIGOURDINE—Name of the dish of ortolans in truffles.

OSEILLE (Fr.)—Sorrel. A green herb used as greens and in soup. PUREE D'OSEILLE—Sorrel soup.

OSWEGO PUDDING—Corn-starch pudding meringued and baked. Made of 1 qt. milk, 4 oz. starch, 3 oz. sugar, 2 oz. butter, 6 yolks; cooked up like thick boiled custard; jelly spread over top in baking pan; whipped whites with sugar on top.

OWL—"M. le Blanc was once chief cook to a Parisian nobleman. For days before Christmas he treated his guests to mouth-watering descriptions of 'ze magnifique dinnair on ze Chrisemas day in La Belle France.' A few days before Christmas he became very mysterious, and intimated that those fortunate mortals who sat at his board should also have a 'magnifique dinnair.' Accordingly anticipations ran high. The day at last arrived. His promises were fulfilled. The table was spread with an embarrassment of good things. One dish was a special favorite, to the undisguised delight of the *cuisinier*. It seemed a species of game, was delicately flavored, but no one knew exactly what it was. 'Oh, monsieur, do tell us what this delicious dish is,' said a young and pretty guest, when the dish was demolished. 'Zat, madam, zat eis ze grand triumph of ze art. Only ze Frenchmen mek ze delicious deesh—zet ees ze vat you call ze owl—ze pet owl.' 'Owl!' exclaimed a chorus of voices, and a dozen wry faces were made. 'Oh, monsieur, how could you have the heart to kill the poor thing?' chirped the fair inquirer. 'It ees you zat mek ze cruel accusations, madam. I no keel him—he die.'"

OX-CHEEK—The meat of an ox-head. It is cooked in various ways, the same as beef, and in soups.

OXFORD SAUSAGES—Specialty; made as follows: Take 1½ lbs. of pig-meat cut without any skin, ½ lb. of veal, and 1½ lbs. beef-suet; mince these meats separately, very finely; then mix them.

## OXG

with a dessertspoonful of dried, powdered, and sifted sage; pepper and salt to taste; and the well-beaten yolks and whites of 5 eggs. The whole should be well beaten together, as much depends upon the mixing. Made into flattened balls and fried.

OX-GALL—Used for cleaning carpets. Can be obtained of the butchers.

OX-HEART—Steeped in acidulated water it is afterwards cooked in slices in various ways, or boiled and then stuffed with goose stuffing and baked.

OX-PALATES—Cooked in many ways the same as sweetbreads. They are first steeped and washed, then scalded or parboiled, and the white horny skin peeled off; after boiled for 2 or 3 hours until tender. OX-PALATE CROQUETTES—Palates cooked tender, cut up extremely small, mixed in thick sauce with the usual croquette seasonings, shaped when cold, breaded and fried. OX-PALATES A LA HORLY—Cut to shape, run on skewers, breaded, fried; served with sauce and croutons. PALAIS DE BŒUF A LA ROBERT—Palates cut in pieces served with Robert sauce. PALAIS DE BŒUF A LA RAVIGOTE—Ox-palates cooked, cut in pieces, coated with white sauce, breaded, fried; served with Ravigote sauce. PALAIS DE BŒUF A LA VIVANDIERE—Same preparation as the preceding; served in a brown sauce with onions, butter, port wine, parsley. (*See Soups.*)

OX-TAILS—Divided in short pieces, steeped in cold water, they are then stewed for several hours to dissolve the mucilaginous substance that surrounds the bone, and dressed in various ways, but principally in soup. HARICOT OF OX-TAILS—Pieces first browned in a frying pan with fat and onions, then stewed in same pan with water for 3 hours, assorted vegetables added, seasoned, thickened; served with the vegetables and potatoes. OX-TAIL SOUP THICK—Good beef stock, a haricot stew like the preceding added to it, the pieces of ox-tail and vegetables served in the plates. OX-TAIL SOUP CLEAR—Clear consommé, neat pieces of ox-tail free from bone, and different-colored vegetables in lozenge shapes served in the plates with it. OX-TAIL SOUP WITH BARLEY—And with macaroni, etc., see *Soups*.

OYSTER—OYSTER QUOTATIONS FOR MENUS—  
 “The man had sure a palate covered o’er  
 With brass or steel, that on the rocky shore  
 First broke the oozy oyster’s pearly coat,  
 And risked the living morsel down his throat.”  
 “An oyster, sir, is one of the elements of social existence, a delicacy of no age, sex, or condition, but patent to the universal family of man. Good in a scallop, better in a stew, best of all in the shell; good in pickle, in curry, in sauce; good at luncheon, before dinner, at supper; good to entertain a friend; good to eat by yourself; good when you are hungry; good, moreover, when you are not.”—“The Greeks, who were the most æsthetical of feeders, had them opened at table, and ate them ‘out of hand.’” They knew as well as we do that to lay an oyster on a dish,

## OYS

no matter for how short a time, diminished its piquancy. Always insist on one point—that the dainty morsel is opened on the *deep* shell, so as to preserve every drop of the liquor. This done, the American asks only crackers, butter, a slice of lemon, and the pepper cruet. The Englishman would put aside the lemon and crackers, and ask for *brown* bread and a few blades of crisp white celery. As regards the size of oysters, I take it that those are best which need no cutting; two bites to an oyster is as inadmissible as two bites to a cherry.”—“An oyster dinner was given in Baltimore the other night, and only oysters were served in eight courses, beginning with raw and ending with a pudding of oysters, crabs and chopped celery that is said to have been very nice.” OYSTERS OUT OF SEASON—“The reason why oysters are procurable in London all the year round is, that certain varieties, when transferred from their original native homes to artificial beds, are so disturbed that they cease to breed, and are consequently fit for consumption at any time.” FORCING OYSTERS—“One of its most remarkable features appears to be the peculiar process adopted for ‘forcing.’ This consists in placing the young oysters into so-called ‘ambulances,’ that is, boxes with wooden sides and tops and bottoms covered with galvanized wire, the boxes being fixed about a quarter of a yard above the ground. The oysters in these boxes grow, we are told, about twice as rapidly as others which are merely placed in the ‘beds.’” OYSTERS AS BRAIN FOOD—“In some of the lower counties, down the Chesapeake Bay, oysters pass as current money, and in one town which boasts of a weekly newspaper a large percentage of its readers pay their subscriptions to it in oysters; thus the editor receives from 150 to 200 bushels of oysters yearly, which he is forced to consume in his own family; and, as oysters are declared by the faculty to be most efficacious in producing and increasing brain power, it is to be hoped that the subscribers to that journal get good value for their oysters.” PICKLED OYSTERS—“Pickled oysters, which years ago were a standard dish at receptions and parties, and then were neglected, have come into gastronomic fashion again.” BROILED IN THE SHELL—“If oysters are to be cooked, a homely excellent way is to lay the shells on the gridiron, and as soon as they open put into each a bit of butter and a dust of cayenne. The French open the shells first, put over the oyster in the deep shell a little *maitre d’hotel* sauce, then lay it on the gridiron, and serve the moment the liquor boils. Americans are as original in oyster stews as in everything else. Almost every family has its own recipe, to which it adheres with an unshakable loyalty.” FRYING IN OIL—Oysters fried in oil were introduced by the late noted Philadelphia *restaurateur* Minico Finelli, an Italian by birth. People who visited Philadelphia always made it a point to go to his restaurant to enjoy this specialty. They were delicious and delicate, beautifully brown, and without a suspicion of grease. PHILADELPHIA BROILED OYS-



## OYS

TERS—Hot oyster liquor prepared first by boiling, skimming, adding butter, salt, cayenne. Large oysters laid side by side in a greased, double-wire broiler, broiled on both sides over very hot fire, then thrown into the oyster liquor. Served with toast aside.—**PHILADELPHIA PANNED OYSTERS**—Oysters washed in cold water and drained; thrown dry into a hot frying pan and shaken about till they boil; butter, salt, and pepper added. Served in hot dish.—**PLAIN BROILED OYSTERS ON TOAST**—Take the largest oysters obtainable; brush the wire oyster-broiler with softened butter, lay in the oysters and broil over a hot fire 2 or 3 minutes, basting once on each side with the butter brush. Dish side by side on one long slice of buttered toast in a dish. Garnish with lemon and parsley. **SCALLOPED OYSTERS**—“At a prominent restaurant the other day we asked for some scalloped oysters. Fancy our disappointment to have served to us a sort of fricassée of oysters. To be sure, it was served in a beautiful silver dish like a scallop shell, and it wasn't a bad kind of a dish, but it wasn't old-fashioned scalloped oysters, so easily made and so toothsome to the palate. If they had made them after this rule I know they would have been good: Roll fine 1 lb. of soda crackers; put a thin layer of this in the bottom of a baking-dish; wet the cracker with the liquor of the oyster. If you are not using shell oysters, wash the oysters first and let them stand in a pint of clear, fresh water for half an hour, then use this and milk for the wetting. In the layer of crumbs place a layer of oysters, well seasoned with salt, pepper, and small bits of butter. On this another layer of bread-crumbs, wet again with the milk and liquor. Then again a layer of oysters, seasoned as before. Repeat this until the oysters are all used. A layer of crumbs should be the last as well as the first, and should be thickly sprinkled with bits of butter. Just before putting in the oven pour over nearly a cup of milk. Bake to a light, crisp brown, and serve instantly.” **DEVILLED OYSTERS**—See *Devilled*. **HUITRES FARCIES DANS LEUR COQUILLES**—Specialty mentioned as forming part of the *Le Conseil Judiciaire dejeuner*: Put a dozen fat oysters into a saucepan. When the liquor is about to boil, place them on a strainer and strain off water. Take this water and boil it with bread-crumbs and a glass of cream until the bread is thoroughly dried up; then place it in a mortar with butter, parsley, minced shallots, pepper, and the yolks of 4 eggs. Work all these ingredients well together with a pestle. Put this stuffing into the oyster-shells, with an oyster in the middle of each, and cover each oyster over with the same *farce*. Cover same with bread-crumbs and bake in oven, serving very hot.” **CALIFORNIA PEPPER ROAST**—Specialty. Oysters in baking plate dredged with Mexican ground sweet pepper, salt and butter; baked in top of very hot oven. Spanish sauce made of oyster-liquor, chopped chillies and tomatoes ready in a hot dish, oysters slipped into it right side up. **STEAMED OYSTERS**—Get a wire basket, fill it

## OYS

with oysters in the shell, and immerse in a vessel of boiling water which is deep enough to completely cover the basket of oysters. They are done almost immediately, and must be opened into a hot dish containing melted butter, pepper, and salt. **OYSTER SAUSAGES**—Take  $\frac{1}{2}$  lb. lean mutton,  $\frac{3}{4}$  lb. beef suet,  $\frac{1}{2}$  lb. oysters scalded and with their beards taken off. Chop all up together, add the yolks of 2 eggs, season with salt and pepper, and make up in the form of sausages, frying lightly in the usual way. **OYSTER CROQUETTES**—Oysters scalded and cut, mixed with soaked crackers, chopped veal, butter, eggs, onion juice; shaped like sausages, breaded, fried. **OYSTER POTATO BALLS**—Potato-croquette preparation with yolks in it, and chopped oysters added; balled, egged, breaded, fried. **OYSTER KROMESKIES**—Oysters cut up in thick sauce made of their liquor, butter and flour, parsley and lemon juice; when cold and firm enough to handle, rolled to shape of bottle corks, each one rolled up in thin shaving of boiled fat bacon, dipped in batter, fried. **ROASTED OYSTERS**—In the shells; placed amongst hot coals, or in a very hot oven; served in the deep shell with spoonful of butter poured over, and toast aside. **FRIED OYSTERS**—Dipped in cracker dust, then in egg, then in cracker dust again, dropped a few at a time in hot lard, fried 4 or 5 minutes. **STEWED OYSTERS**—Oysters and their liquor boiled one minute; boiling cream in another saucepan added with salt, pepper and butter to the oysters. **FANCY STEW**—The above with a square of toast in a bowl, oysters on the toast which floats in the cream. **OYSTERS A LA TARTARE**—Oysters scalded and cold served with tartar sauce. **HUITRES A LA VILLEROI**—Large oysters, each coated with Villeroi sauce, bread-crumbed and fried. **HUITRES EN PAPILLOTES**—Oysters rolled in oval-shaped pieces of a paste made of mashed potatoes, flour and butter, and baked. **HUITRES A LA DIABLE**—Broiled oysters with butter, lemon juice, and cayenne. **HUITRES AU PARMESAN**—Oysters in pan with little wine, chopped parsley, bread-crumbs, Parmesan cheese and bits of butter on top; browned. **ANDOUILLETES AUX HUITRES**—Oyster sausages. **CROUTES AUX HUITRES**—Oysters, pounded with cream and spread on small pieces of toast. **RISsoles AUX HUITRES**—Same preparation as for croquettes or kromeskies, rolled up in thin puff-paste and fried. **BOUCHEES AUX HUITRES**—Small oyster-patties. **PETITS PAINS AUX HUITRES**—Small oyster-loaves; rolls fried outside, inside hollowed and filled with stewed oysters. **FRIED OYSTERS A LA FORTRESS MONROE**—Drained, dusted with red pepper, rolled in cracker dust, dipped in egg mixed with whipped cream, then in fine white bread-crumbs; fried. Salted, served with lemon and parsley.—**FRICASSEED OYSTERS**—Oysters boiled 2 minutes, liquor strained, thickened with flour and butter and yolks; oysters have sauce poured over them. **BAKED OYSTERS A LA DUXELLES**—Fricasséed oysters with mushrooms added, with cracker dust on top, browned in the oven. **OYSTERS A LA MILANAISE**—Cooked

## OYS

macaroni with oysters in alternate layers, yellow sauce poured in, cracker dust on top; browned in the oven. OYSTER CATSUP—Pounded oysters with their liquor, salt, spices; heated to a boil, little plain proof spirit added; bottled. OYSTER STUFFING—Oysters mixed with bread and crackers with butter, etc., to stuff fowls with. OYSTER SAUCE—See *Sauces*. OYSTER SOUP—See *Soups*. CURRIED OYSTERS—Are put up in cans, same as the familiar canned plain oysters. OYSTERS, ENGLISH NATIVE—

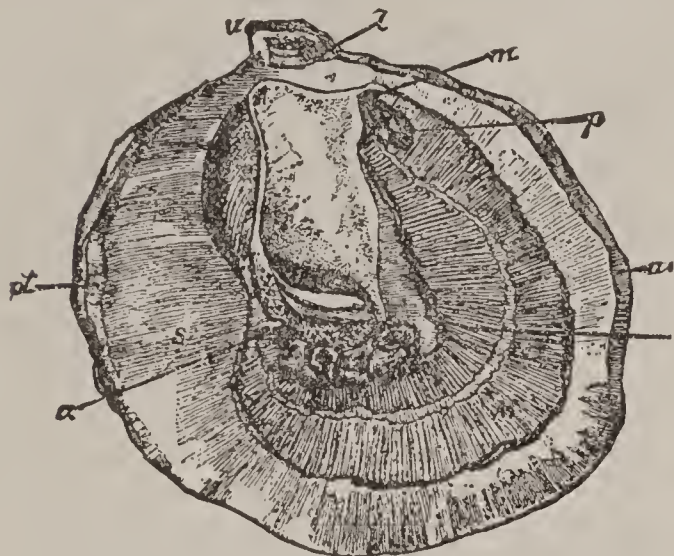

The cut shows the shape of this oyster which the English claim is the best for eating from the shell. The difference in form of shell from the American oyster can be seen by reference to the cut of "Blue Point," on page 254.

OYSTER-PLANT—*Salsify*, *Scorzonera*. A white root with the taste of oysters. Grows to about the thickness of a finger. Is best after frost in the spring of the year. STEWED OYSTER-PLANT—Scraped, boiled in water containing a little vinegar, salt, and flour to slightly whiten it; when tender, cut in short pieces in white sauce. FRIED OYSTER-PLANT—Boiled, cut in lengths, dipped in batter, fried like fritters. OYSTER-PLANT FRITTERS—Boiled tender, mashed, stirred up with egg, little flour, butter, salt, pepper; spoonfuls dropped in hot lard. SALSIFIS A LA CREME—Boiled, cut in pieces in cream sauce. SALSIFIS A LA MOELLE—Oyster-plant boiled, cut up and stewed in brown sauce; served on toast spread with hot beef-marrow. SALSIFIS A LA POULETTE—In yellow sauce thickened with yolks, and mushrooms added. BEIGNETS DE SALSIFIS—Fritters of oyster-plant.

## P.

PAILLES AU PARMESAN—Cheese straws. Although called straws the paste is better looking and better to bake if cut with a paste cutter into strips  $\frac{1}{4}$ -inch wide. Equal quantities of butter, cheese and flour are pounded together to make it, but one or two yolks and a sprinkling of water improves it.

PAIN (Fr.)—Bread. PETITS PAINS—Small loaves, rolls. PAINS DE LA MECQUE—Mecca loaves, cream puffs. PAIN DE FOIE DE VEAU—Mould or loaf of liver

## PAN

paste. PAIN DE PERDREAUX—Mould or loaf of purée of partridge. PAIN D'ABRICOTS—A mould of apricot cheese. PAIN DE POMME A LA RUSSE—A mould of apple marmalade with whipped cream in the center and currant jelly round. PAIN is the equivalent of English cheese in head-cheese, liver-cheese, etc. "Very excellent *pains* or *crèmes* can be made of *purees* of delicate meats, fish and vegetables—*creme de homard*, *creme de crevettes*, *creme d'artichauts*, *pain de gibier*, etc. If required to be

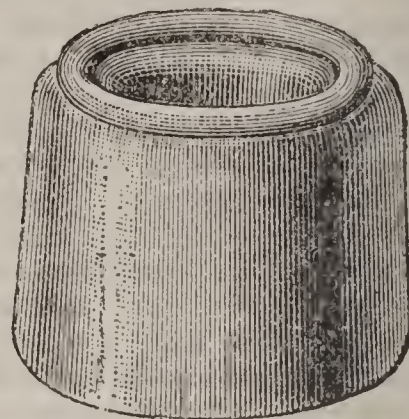

HOLLOW BORDER MOULD,  
for Pains de Volaille Aspics, Jelly Salads, etc.

served hot, the contents of the mould must be steamed like a pudding, the cream being stirred into the custard in the first instance." "Little cakes made out of rye-flour and abundant currants are very popular in Paris. These *pains de seigle*, as they are called, are sold by all the bakers." PETITS PAINS A LA FIANCEE—Rich nut cakes made of 10 oz. hazel nuts pounded with cream, 10 oz. sugar, 2 oz. butter, 18 yolks, 8 oz. rice flour. Baked in sheets on paper, cut in diamonds glazed and iced.

PALAIS DE BŒUF (Fr.)—Ox-palate.

PANADA—Bread soaked in milk or water and squeezed dry. It is used in making stuffing, quenelles, forcemeats, puddings.

PANCAKE—The pancake is the oldest form of bread and there are remains of ancient ceremonies and popular customs in regard to it still observed in some places of which the original significance is now unknown. In Catholic communities and countries which formerly were Catholic the custom is observed of eating pancakes on Shrove Tuesday, which is at the beginning of Lent. It is a pancake feast in which everybody joins, the French perhaps keeping up the observance with the greatest vigor.

PANCAKE PARTIES—"This reminds one that last year pancake parties were all the go at the fashionable seaside places in France. At Etretat especially it became quite a mania. The pancake batter was brought on the beach ready mixed in a jar, and a small portable charcoal stove was erected in a sheltered corner against the rocky shore. The other indispensable components of the pancake, such as sugar, lemon, and butter, were also brought in a hand-basket, as well as bottles of cider, the only beverage allowed. It was rather an amusing sight

## PAN

to watch a group of elegantly dressed people sitting on the beach around a gentleman in shirt sleeves with a white apron before him, handling the frying-pan amidst the jokes and chaffing of the audience; and bets were often made as to the tossing abilities of the amateur *cuisinier*. It often happened that when the pan was handled by an inexperienced or nervous person, the unfortunate pancake was tossed up so awkwardly that it dropped half cooked into the cinders, to the merriment of all present. It is not everyone who knows how to toss a pancake properly. The process looks simple enough, but it is by no means so easy as it appears. In fact, it requires much skill and practice to perform the feat with success." **AMERICAN PANCAKES**—The pancake has become thoroughly domesticated in America in the form of batter-cakes, which many people eat twice a day the year round, a habit which seems to be peculiarly American and not indulged in anywhere else in the world. It follows that we have several varieties of pancakes and an easier and more rapid way of cooking them than in a frying pan one at a time, for we have a griddle which will bake a dozen or two at once or fry them in grease as well as a small frying pan. The chief difference between the American wheat flour batter cake and the French pancake is, that the former is (generally) made light with some raising material, the French cake is but plain batter which would be tough if the cakes were not so very thin. **ENGLISH PANCAKES**—The English mix their pancakes with ale and give them time to rise, for ale acts the same as yeast and their pancakes are light in consequence. Hence the difference in form. The English pancake is not rolled up, being through its light texture somewhat too thick to roll well, but is sent in hot from the pan, dredged with fine sugar and sprinkled with lemon juice. **FRENCH PANCAKES**—The French pancake is baked thin as paper; is spread with some sweet preparation, rolled up like an omelet, the ends cut off; a number are baked in advance, placed on a dish, sugared over and the top glazed by melting the sugar in the top of a hot oven or by holding a red hot iron close to it. This is the French pancake which becomes familiar to hotel guests as the sweet entremet "French pancakes with jelly." **PANCAKE BATTER, AMERICAN**—8 oz. flour, 2 teaspoons baking powder, 1 egg, 1 tablespoon sugar,  $\frac{1}{2}$  teaspoon salt  $1\frac{1}{2}$  cups milk or cream, 1 tablespoon melted butter or lard beaten in. **GERMAN PANCAKES**—A regular article of sale at the restaurants by this name is a pancake  $\frac{1}{2}$  inch thick, baked as usual in a frying pan but requiring considerable time. The batter is made as for light American pancakes. Eaten with butter and sugar or syrup. **PANCAKE BATTER, ENGLISH**— $\frac{1}{2}$  pt ale,  $\frac{1}{2}$  pt water, 6 yolks, little salt, about 1 pt flour, 1 glass brandy. **PANCAKE BATTER, FRENCH**—4 oz. flour, 4 eggs, little grated lemon peel, salt,  $\frac{1}{2}$  pt cream,  $\frac{1}{2}$  pt milk. To be baked very thin in the pan, turned over, spread with jelly or marmalade, sugar on top. **SWISS PANCAKES**—6 eggs, 6

## PAP

oz. flour, 1 qt milk, salt. Eggs to be whipped light, all made into smooth batter like thick cream. When in the pan some currants shaken in, not rolled but served with sugar dredged over. **DANISH PANCAKES**—Made small and thin, spread with purée of chestnuts, doubled over in half, sugar on top, glazed, served with apple sauce and cream. **PANCAKE SOUFFLES**—Plain, thin pancakes are baked and spread with frangipane pastry cream in which some whipped whites has been mixed. The pile of cakes then baked in the oven are served while light and hot. **POTATO PANCAKES**—An excellent supper-dish. Grate a dozen medium-sized peeled potatoes. Add the yolks of three eggs, a heaping tablespoonful of flour, with a large teaspoonful of salt, and lastly the whites of the three eggs beaten stiff, and thoroughly incorporated with the potatoes. Fry the cakes in butter and lard (equal parts) until they are brown. **PANCAKES WITH PEACHES**—Rolled up with peach preserves or fresh stewed peaches. **PANCAKES A LA MANCELLE**—Spread with purée of chestnuts flavored with maraschino. **CREPES AUX CONFITURES**—Pancakes spread with jelly or preserve and rolled. **CREPES AU RIZ**—Rice pancakes. (*See Crepes.*)

**PAON (Fr.)**—Peacock.

**PAPER CASES**—Little paper boats, cups or boxes in which dainty small fish or birds are baked in sauce, or souffles are baked instead of in cups, or ices are frozen and served. They can be bought ready made at confectioners' supply stores; are of various fancy forms, crimped and fluted, and some are of the finest delicate rice-paper. Where these cannot be obtained sometimes there is a paper box maker who will furnish some of a plainer sort, the box machinery cutting the paper for cases in short order; but otherwise the cases can be made at home by clipping fine white paper to shape and pasting up the ends or sides. They should hold from  $\frac{1}{4}$  pt. to  $\frac{1}{2}$  pt. according to use intended.

**PAPER FRILLS FOR CUTLETS**—Paper cut in fringe and coiled in spirals around the bones of lamb or mutton cutlets to serve at party breakfasts. They can be bought by the gross cheaply. If to be made at home double a sheet of paper and clip the doubled edge to fine fringe, then move the other edges of the paper one lower than the other and the fringe will bow open, fasten so with paste, roll around a pencil, and the fringe paper will retain spring enough to coil around the bone.

**PAPER RUFFLES FOR HAMS**—Same as the preceding, or larger size to place upon the shank bone of a decorated ham.

**PAPER NAPKINS**—See *Japanese*.

**PAPER-SHELL ALMONDS**—Soft-shell or Jordan almonds.

**PAPILLOTE, EN (Fr.)**—In paper. Lamb and mutton chops in some styles are cooked in paper. White unruled paper is cut to the shape of a heart,

## PAR

brushed with melted butter, the cutlet and sauce or forcemeat placed on one side, paper doubled over it, the edges fastened by pinching them up together and baked on a wire broiler. Some styles are finished by making gridiron marks on top of the papers and serving in the papers as if broiled; in others the papers are removed before serving. "Pompadour" and "Maintenon" are among the paper-covered styles.

**PARMENTIER**—A man remembered in connection with the introduction of the potato in France, and who caused it to be adopted as food. The potato had been known and eaten in England and Spain for 150 years before but had been kept out of France by a popular prejudice. At the period of a famine of bread-stuffs Parmentier applied to the King, Louis XVI., who aided him, and by the ruse of guarding the precious field of potatoes, ostensibly, with soldiers, the populace were induced to steal them and a demand was thereby created and the potato was adopted into general use. He died in 1813. **POTAGE PARMENTIER**—Potato soup; a purée of potatoes with cream and butter. (*See soups.*)

**PARMESAN**—Cheese. A kind of Italian cheese especially used for cooking purposes, and always in the grated form. It is mixed in everything denominated *au Parmesan*, when if other kinds of cheese are used the name becomes *au Fromage*—which means any kind of cheese. Parmesan is directed to be served with all soups containing macaroni or other Italian pastes; it is found, however, in our hotels that the attempt is not often successful, the offer of grated cheese not always being taken in good part. This remarkable cheese has the property of keeping for an indefinite period, and growing as hard as a stone without losing aught of the delicacy of its flavor. It is not generally eaten as cheese, yet is very toothsome grated and mingled with butter into a paste to be spread on toast or biscuit. It can be bought ready grated in bottles at the Italian warehouses and fancy groceries and is used in that form at most American hotels.

**PARR**—A fish, the young salmon. Up to the age of two years the salmon has dark markings and is without the silvery luster which is its characteristic when mature.

**PARSLEY**—This well-nigh indispensable herb can be grown easily from the seed in a box in a cellar or in a garden corner; it can be propagated also by dividing the roots. Its flavor is mild but pleasant and especially suits fish, chicken and potatoes. The roots are better in soup than the leaves. The latter in the curly variety furnishes the most ornamental green garnish for many dishes. Chopped finely and squeezed dry by twisting in a towel it makes a green powder very much prized for dusting over white stews, etc., while the green juice expressed is useful for coloring sauces, making green butter and adding to the color of green pea soups. Parsley sweetens the breath and takes away the odor of onions, eaten

## PAR

in potato salad, in which it is one of the principal ingredients. **FRIED PARSLEY**—Is useful to garnish dishes of fowl, etc. Wash and thoroughly dry the parsley in a cloth, and fry it in boiling fat for a couple of minutes, or till it is crisp. Take it out with a slice; and dry before the fire.

**PARSNIP**—A root like a carrot, nearly white; best in the spring after being frozen in the ground. **BOILED PARSNIPS**—Generally eaten with boiled meat or fish. The parsnips pared, boiled about an hour in salted water, served in broth. **BROWNEED PARSNIPS**—Split lengthwise, boiled, then browned in the oven with salt and fat from the roast pan. **FRIED PARSNIPS**—(1)—Boiled, cut in slices, dipped in flour and browned in a frying pan. (2)—Slices (after boiling) egged and breaded, fried by immersion in hot fat. **PARSNIP FRITTERS**—Mashed parsnips with butter, pepper, salt, egg, little flour; soft mixture dropped by spoonfuls in hot fat. **PARSNIP CAKES**—Same as above without eggs, in flats browned in pan. **STEWED PARSNIPS**—Boiled, cut small in cream sauce.

**PARTRIDGE**—The old bird confessedly has a much higher flavor than the young one but do what one may the cook will never obtain the delicacy and tenderness which are characteristic of the young birds. The best way to prepare partridges in perfection is to cook old and young together; the old birds to impart flavor, the young ones only to be



PARTRIDGE—PERDREAU OR PERDRIX.

served at the table in the first instance, the others to appear in other forms than roasted or boiled, as in salmis or soups. **PERDRIX AUX CHOUX**—Boiled partridge with cabbage. One of the national dishes of France. Two young and one old partridges in a stewpan with 3 or 4 heads of cabbage, 4 sausages, 1 saveloy,  $\frac{1}{4}$  lb. parboiled bacon, parsley, 1 qt. stock, 1 glass sherry; simmered an hour, young partridges taken out, cabbage, etc., cooked longer. Cabbage pressed, chopped, placed on dish with sliced sausages and bacon as a border, partridges carved and piled in the middle, liquor remaining mixed with brown sauce poured over. **SALMIS DE PERDREAU A L'ANCIENNE**—If you wish for a salmis possessing all desirable qualities do not use the leavings from a previous day, but let the bird be roasted  $\frac{1}{2}$  hour before dinner, cut it up while still warm and keep in a closed saucepan while sauce (*fumet*) is made of

## PAR

the bones and trimmings with sherry, onion, thyme,  $\frac{1}{2}$  a bay leaf, peppercorns and mushrooms and brown sauce. Boil down, strain and pour it over the cut up partridge. **ROAST PARTRIDGE**—Young birds that have been hung a while, slice of bacon over the breast tied on, roasted in the oven about  $\frac{1}{2}$  hour. Served with game sauce like that with salmis or with jelly. **PERDRIX A LA CATALANE**—Partridge browned on the outside in a pan with chopped bacon, onion and aromatics, wine added, braised gently. Raw ham cut in dice, a cupful of cloves of garlic previously parboiled and red pepper added. **BROILED PARTRIDGES**—May be served with poor man's sauce and Indian pickle. Old partridges are only fit for stewing with cabbage, for stock broth, and glaze of game; but are too tough for anything else. **BRAISED PARTRIDGES**—Larded on the breasts, covered with buttered paper in a saucepan with vegetables and aromatics, braised in own steam and liquor 2 hours. **STEWED PARTRIDGES**—Cut in joints, half-fried, broth added, stewed tender, orange juice and little of the peel, butter and flour



BALLOTINES OF PARTRIDGES,

Or any small birds on rice stand, jelly, truffle on top, etc.

to thicken. **COTELETTES DE PERDREAUX A LA BACCHANTE**—Breasts of partridge flattened, a piece of bone or macaroni stuck in each, bread crumbed and fried, served with white game sauce with raisins, juice of grapes, etc. **FILETS DE PERDREAUX AUX PETITS LEGUMES**—Breasts of roast partridges dressed in a crown with young onions, carrots and turnips, cut in shapes and glazed, and game sauce. **EPIGRAMME DE PERDREAUX AUX CHAMPIGNONS**—Two kinds of fillets. (See *Epigramme*.) **PERDREAUX EN ESCALOPES AUX TRUFFES**—Thin round or oval slices from the breast in a white game sauce with truffles. **CHARTREUSE DE PERDREAUX**—An ornamental mould of vegetables filled with larded and braised partridges, pieces of sausage, dice of bacon and jelly. (See *Chartreuse*.) **PERDREAUX EN SOUFFLE**—Purée of roast partridges with cream, yolks,

## PAS

and whipped whites, baked in paper cases. **PARTRIDGES A L' ANDALOUSE**—Outside fried with butter and ham, espagnole, water, sherry, parsley, aromatics, red pepper, all stewed together 40 minutes. Sauce strained. **BOILED PARTDIDGE WITH CELERY**—Boiled with salt pork and vegetables; purée of celery poured over.

**PARFAIT** (Fr.)—Perfect; perfection. Applied to some kinds of sweets and to ices. Same as excellent. (See *Ices*.)

**PASTE CUPS**—Like the paper cases, but formed of paste, almost as thin as paper, done by dipping an iron shape into pancake batter and holding the shape in hot fat until the thin coating of batter is fried and will come off. The shape or mould is like a small tumbler in shape, but may be of any other form; made of iron or copper, either solid or hollow, has a stout wire handle joined to the top to hold it by. If there is no shape to be had, a substitute is to use tin patty pans or shells, dip the outsides in batter and drop them in hot lard, take off and dip again. Most depends on the batter, it must not have any raising or shortening in, but made same as French pancakes, with 3 eggs, 1 pt. milk and about 3 oz. flour. **OYSTERS IN PASTE-CUPS, OR CAISSES**—Same as patties; oysters in either white or yellow sauce, sprig of parsley on top. **PASTE-CUPS AU SALPICON**—Meat of any kind cut in very small dice, seasoned, mixed with mushrooms, parsley and white sauce; same as chicken patties. **COMPOTE OF FRUITS IN PASTE CUPS**—Dished like vol-au-vents.

**PASTE**—Several kinds are made. **SHORT PASTE**—The commonest only slightly shortened has  $\frac{1}{4}$  lb. of either suet, lard, or butter to a pound of flour. Next, for boiled dumplings, has  $\frac{1}{2}$  lb. shortening to a pound of flour. Best, for pies and baked dumplings and timbale linings, has  $\frac{3}{4}$  lb. shortening to the pound. **PUFF SHORT PASTE**— $\frac{3}{4}$  lb. shortening to a pound of flour;  $\frac{1}{4}$  lb. of it rubbed in dry, like all short paste, remainder rolled in flakes like puff paste. **SWEET TART PASTE**—Short paste with little sugar and egg mixed in, for fruit tarts and cheese-cakes. **ALMOND PASTE**—See *Almonds*. **NOUILLES PASTE**—See *Nouilles*. **GUM PASTE**—See *Gum*. **PUFF PASTE**—*Feuilletege*. This singular and highly ornamental paste consists of layers of flour and water dough rolled to the extreme of thinness with alternate sheets of butter between. Suppose a sheet of dough made of plain flour and water only, spread out 1 inch thick; on top of that a similar sheet of butter  $\frac{3}{4}$  inch thick. The paste is folded over in 3, the butter in it keeping the layers of paste separate. When it is rolled flat again there will be 3 layers of dough where at first was only one. Fold in 3 again and there will be 9 sheets of dough in the same thickness; fold and roll the third time and there are 27 sheets of dough; the fourth time produces 81 layers, the fifth time 243 layers in the inch, the sixth time 729, and then the paste is ready for use for some purposes; but to be at its best one more fold-

## PAS

ing and doubling is required, which makes 2,187 layers or sheets of paste to the inch. The art of making puff paste consists in keeping the butter in that state of firmness, yet pliable, that it will continue to roll along with the paste and will keep the flakes evenly apart, otherwise the layers of dough either break or adhere to each other and the result is a failure. The rule is 1 lb. butter to 1 lb. flour and an ounce or two more to dust with; the ingredients must all be cold. Used for various fine pastries, tarts, open pies, patty cases, turnovers, etc. **HOT WATER PASTE**—For raised pies; is made of  $\frac{3}{4}$  lb. melted butter to each pound of flour and  $\frac{1}{2}$  pt. water, butter and water both made hot and poured into the flour, then stirred up to stiff dough. (*See Pies.*)

**PASTILLAGE** (Fr.)—Gum paste.

**PATATES** (Fr.)—Sweet potatoes.

**PATISSERIE** (Fr.)—Pastry. **PATISSERIE D'AMANDES A LA CONDE**—Fancy shapes of puff paste covered with chopped almonds and sugar in large grains. **PATISSERIE A LA TARTINE**—Sandwiches of puff paste and jam.

**PATE** (Fr.)—Paste and pie, especially the raised pie, of which the shell is formed in a mould and baked in it, and filled with meat or birds afterwards and baked a short time longer.

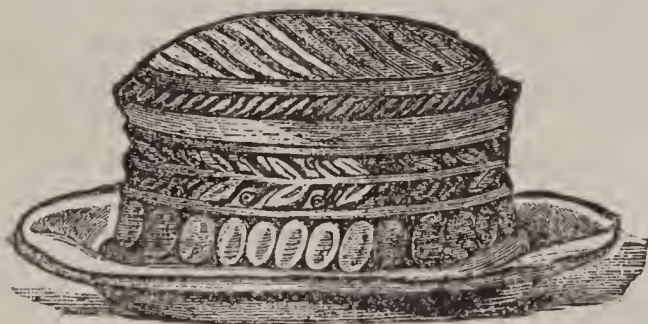

FRENCH PATE.

**PATE MELE**—Mixed pâté; a raised pie filled with several kinds of meat cut in small blocks, interspersed with mushrooms, almonds, pistachios, and small pickles, all solidified in the pie shell with jelly. To be eaten cold. The wall is short paste pressed into the pattern of the tin mould, which opens on hinges, the shell is then filled with flour and baked, then emptied, decorated with *nouilles* paste, filled, egged over and finished in the oven, and filled up finally with aspic jelly and wine through a hole in the lid. **PATE D'EMINCE**—Mince pie. **PETITS PATES DE VOLAILLE**—Small chicken patties. **PETITS PATES A LA BOURGEOISE**—Small patties filled with veal forcemeat. **PETITS PATES DE MOUTON**—Small covered patties filled with minced mutton, brown sauce and chopped mushrooms. **PATE CHAUD D'AGNEAU**—Lamb pie, hot. **PATE A LA LEICESTERSHIRE**—A pork pie made as in the engraving. **PATE CHAUD DE LAPEREAX**—Hot rabbit pie. **PATES D'ITALIE**—Italian pastes. **PATE DE FOIE GRAS**—Liver paste.

## PEA

**PATTIES**—Two distinct kinds are generally understood by this term. (1) The puff paste shell or *vol-au-vent*, baked by itself, and the hollow middle filled afterwards. (2) Tiny pies made by lining patty-pans with short paste, filling with the oysters, chickens, etc., and covering with a top crust. The *petits pates* are generally of puff paste, without patty-pans; the smallest are called *bouchees*. **PATTIES DE CREME DE VOLAILLE**—“Make a purée of fowl, cooked in milk (no salt). Use the milk in passing the purée through the tammy; put the whole over the fire in a saucepan, with 2 tablespoonfuls of white vegetable soup; stir till the purée is quite thick, then season with salt. Have puff-paste cases ready, three parts fill with the puree; decorate the top with white of egg, whipped to a stiff foam, colored with saffron, spinach, cochineal, etc.; season with salt, and dry in the oven, but do *not color*. Set on stands, with lace-paper under the pastry, and a centre piece of flowers rising out of the middle of the stand.’

**PAUPIETTES**—Thin slices of meat stuffed, rolled up and cooked. The same which the English call meat-olives. **PAUPIETTES DE VEAU**—Slices cut from the fillet spread with forcemeat, rolled, and stewed with stock and wine.

**PAW-PAW**—A wild fruit of the Middle States, shaped somewhat like a banana, but thicker. Grows on a tree of small dimensions, in bunches of 3 or 4. When ripe, it contains a yellowish pulp which resembles an over-ripe muskmelon in taste, and there are several seeds like broad beans. It is eaten by some, but not much sought after.

**PAYSANNE** (*a la*)—In country style.

**PEACH**—One of the choicest of American fruits; grows largest, choicest, and in greatest number of varieties. Delaware and California produce the most constant crops and control the canning business of the country. California canned peaches in syrup are the same as the compote peaches of French cookery and are ready for use when opened. **PEACHES AND CREAM**—The fruit is pared, cut in small pieces, mixed with sugar and cream in a bowl, served with cake. If peaches are handsome it is advisable to serve them whole, as they present an appetizing appearance. Wipe them thoroughly, arrange them neatly on a dish, and decorate with peach leaves. A border of the rose of Sharon (*narcissus*) presents a very pretty contrast. **PEACH SHORTCAKE**—Chopped free-stone peaches mixed with sugar spread between and on top of a split cake of plain short paste, or on round sheets of puff-paste baked separately. Eaten warm with cream. **BROILED PEACHES**—Specialty. Halves of peaches stuck full of split almonds and peach kernels, dipped in powdered sugar, broiled in the double wire broiler, served hot, covered with scalded cream, orange-flavored, and croutons of sponge cakes fried in butter around in the dish. **PEACHES A LA WINDSOR**—Two halves of peeled peaches placed in natural

## PEA

form in a cup cut out of sponge cake, sugared over, glazed and cooked sufficiently in the oven; peach syrup with maraschino for sauce. **PEACH CHARLOTTE**—See *Apple Charlotte*. **PEACHES A LA CONDE**—Halves of peaches on a bed of cooked rice, decorated with rice croquettes; marmalade, peach syrup and Madeira for sauce. **PEACHES A LA RICHELIEU**—Halves of peaches served on round sponge cakes dipped in kirschwasser syrup, garnished with mixed fruits, citron, etc., in the syrup. **SUEDOISE OF PEACHES**—A peach pyramid made of half peaches on fried rounds of bread built up in the dish around a center piece. Syrup poured over. **TARTE DE PECHES**—French open peach pie. **FLAN DE PECHES**—Open peach pie with custard on top of the fruit. **BEIGNETS DE PECHES**—Peach fritters, made same as apple fritters with halves of peaches. **BEIGNETS DE PECHES AU VIN DU RHIN**—Made with peaches steeped in Rhine wine, and wine syrup for sauce. **PAIN DE PECHES**—A mould of peach cheese or marmalade stiffened with gelatine. The center is hollow and filled with whipped cream. See *Bo der Moulds*. **CHARTREUSE DE PECHES**—(1) Mould ornamentally lined with sliced peaches, and filled with peach marmalade. (2) Make a purée of canned peaches, blanch and slice six bitter almonds, sweeten the purée, mix in the almonds, and also one oz. of gelatine for each quart mouldful of the purée. Line the moulds with slices of fruits of all colors. The French dried and preserved *bombon* fruits are best for this purpose. Dip each piece in nearly cold strong calfs-foot jelly, and let it be placed in position. Work out a pattern of mosaic design with the fruits. When set, fill with apricot mixture, and serve with Devonshire clotted cream around the base of the mould. Turn out as you would a jelly. **RISSOLES OF PEACHES**—Spoonful of peach marmalade inclosed between the flats of puff paste, egged, breaded and fried. **PEACH TART A LA MONTREUIL**—Kind of pie of peaches with rice at bottom and top. **PEACH MERINGUE**—Ripe peaches cut small on a sheet of cake, covered with meringue, sugar sifted on top, baked light color. **PEACH DUMPLINGS**—Same ways as apple dumplings. **PEACH COBBLER**—Popular Southern dish; a peach pie baked in a large, shallow pan, served with the natural peach syrup and cream. **PEACH ICE**—Puree of peaches in syrup and glucose, frozen. **PEACH ICE CREAM**—Ripe peaches cut small, frozen in cream and sugar. **PEACH PIES**—Same ways as apple pies. **PEACH CIDER**—Common in some districts; made like apple cider. **PEACH BRANDY**—Like “Apple Jack,” distilled from peaches; abundant and cheap in some sections. **DRIED PEACHES, PEACH PRESERVES, MARMALADE, PEACH BUTTER, BRANDIED PEACHES** are other forms in which surplus peaches can be used, and **PEACH VINEGAR** and **PEACH SWEET PICKLES** are highly esteemed in the peach growing states. **ICED PEACHES**—“Another dessert dish is composed of peaches. These are cut open, the kernel is next removed, its place being filled up

## PEA

with delicious peach-ice flavored with maraschino. The two halves are then cemented together with a thin layer of the same ice, the fruit passes an instant in the freezer, and is then served. Other stone-fruits are treated in the same way.” For other ways to cook and use peaches see *Apples, Apricots, Pears*. **GERMAN PEACH KALTECHALE**—In Germany a favorite and very pleasant bowl or “cup” is often made of peaches, sliced and soaked for a time in a little water with sugar, and three or four bottles of Rhine wine poured over them, according to the amount of fruit used.

**PEACOCK**—Formerly served at royal banquets with the utmost pomp and ceremony, generally with its plumage replaced after cooking and its beak and claws gilded. It is occasionally now sold for turkey and passes without the difference being noticed. The reason for its not being now in general use for the table is the harsh, unsociable nature of the bird, which makes the rearing too troublesome and too destructive to other poultry to be followed for profit. **THE PEACOCK AS A DECORATOR**—“At all banquets, both of the elder and of the middle ages, the peacock was a favorite piece of decoration. Sometimes it was quite covered with leaf-gold, as if that were an improvement upon its brilliant dyes, and with a bit of linen in its mouth, dipped in spirits and set on fire, it was served on a golden dish by the lady of highest rank, attended by her train of maidens and followed by music, and was set before the most distinguished guest. This was a performance of great state and ceremony, and the bird was held in so far sacred that oaths could be taken on its head.

**PEA-NUT**—The ground nut or ground pea. It grows in little mounds of earth and the nuts form on the roots. Enormous crops are raised in Virginia, the Carolinas and Tennessee. The bulk of the nuts are eaten roasted, large quantities are converted into oil which passes for olive oil, palm oil, etc.; some are used in candy.

**PEAR**—The pear is produced in the greatest perfection and abundance in California. The Bartlett variety is the best for table use. Shipped in boxes in its fresh state to all parts it is obtainable almost everywhere in the season. Canned in syrup it is equally a choice fruit for table use in that form. **SUEDOISE OF PEARS**—See *Suedoise of Peaches*. **PEAR CHARLOTTE**—Same as apple Charlotte. **PEARS A LA MARQUISE**—Pears on a rice border with whipped cream in the center. **TARTE DE POIRES**—Pear tart. **FLAN DE POIRES**—Open pear pie with custard or cream on top. **BEIGNETS DE POIRES**—Pear fritters. **BAKED PEARS** are most suitable for a luncheon dish. Obtain some good baking pears, peel and cut in half, removing the cores; place them in a large brown jar with 1 lb. of loaf sugar to 4 lbs. of pears, also the thinly cut peel and juice of a large lemon; cover closely, put in a slow oven, and bake until tender) (*See Raisine de Bourgogne*.) **COMPOTE OF PEARS** forms a nice sweet at this time of the year. Stew

## PEA

your pears in clarified sugar, flavor with strips of lemon-peel and color the sugar with cochineal. serve cold in a glass dish. **PEAR MARMALADE**—Boil the rind of one lemon and 1 oz. bitter almonds in a pint of water for half an hour. Take them out and add one lb. fine sugar. Boil till dissolved, then add the juice of three lemons, 3 lbs. pears cut into chips, and  $\frac{3}{4}$  lb. more fine sugar. Simmer gently till the chips are transparent. Store in jars. (*See Apples, Apricots.*)

**PEAS**—**GREEN PEAS A LA FRANCAISE**—Boiled and white sauce added. **GREEN PEAS A L'ANGLAISE**—Dressed with butter and salt only. **PETITS POIS A LA PARISIENNE**—Boiled with onions, butter, salt and sugar and served with the sauce. **PETITS POIS AU JUS**—Stewed in stock. **PETITS POIS A L'ANCIENNE**—Boiled, put into cream sauce; made yellow with yolk of egg. **PETITS POIS AU JAMBON**—Stewed with ham cut in dice and young onions. **PETITS POIS EN CASSES**—Green peas boiled in the pods. **MARROWFAT PEA**—A large and late variety of green pea. **SPLIT PEAS**—English yellow field peas hulled and split, used principally for making soup, but good as a winter vegetable and as a purée with salt meats. **BLACKEYED PEA**—A Southern variety, like a bean, very generally eaten in the South; cooks to a dark color. **LADY PEA**—White Southern variety, very small, scarcely larger than wheat, cooks yellow; not so coarse as the black-eye pea; in good demand for the table. **GREEN PEAS BOILED IN THEIR SHELLS**—There is a pea now cultivated which, when young, has such tender shells, that they are able to be eaten as well as the peas. Boil for half an hour in water, drain, and warm in butter. Stir in some cream; thicken with yolks of eggs, and flavor with a few drops of vinegar. **OUR COMMON SPLIT-PEA SOUP**—Wholesome and agreeable in winter, with dried mint and tiny croutons, is wholly unknown in France; the dried green peas, termed *pois casses*, only are used for similar purposes there.

**PECTOSE**—The jelly making constituent of fruit, abundant in the cranberry and crab apple. "Besides these juices, sugar, cellulose, starch, and vegetable albumen, there is an important constituent of succulent fruits to which the name of *pecten*, or *pectin*, or *pectose*, has been given. It is vegetable jelly, also contained in turnips, parsnips, carrots, etc., but in smaller proportions. We all know it in the form of currant jelly, apple jelly, etc. In its separated state it is about the most digestible food in existence.

**PELAMIDE (Fr.)**—Pilchard, a full grown sardine; fish like a herring.

**PEMMICAN**—Often named in relation to Indian or Arctic life; it is beef dried and pounded to powder, mixed with beef fat and sometimes with dried fruits such as currants; packed in cakes and bags.

**PEPPER**—Ground pepper is subjected to adulteration to a greater extent, probably, than any other commodity required in the hotel storeroom,

## PEP

and the simplest means to avoid imposition is to buy the pepper in the whole state and have it ground in the house. So systematic is the practice of the manufacturers of ground spices they make little or no disguise of the fact, but only of the kind of adulterants employed, for the buyer in quantity is offered different grades, as "pure, first adulteration, second adulteration, and third adulteration," according to the price he is willing to pay. Where pepper is purchased for use and not for re-sale it is manifestly the cheapest plan to buy the "pure," if it be pure, or the whole berry and grind it. The stuff found in adulterated peppers is, in various mixtures, mustard hulls, peanut cake, ground olive stones, cocconut shells, meal, sand, spent ginger, charcoal, etc., the commonest and cheapest samples containing no pepper at all but the dust and tailing from the mills. **BLACK PEPPER**—Is the seed of a perennial climbing plant found growing wild in parts of India, but is extensively cultivated. The seeds or pepper corns are gathered just before they are ripe and are dried on mats. **WHITE PEPPER**—Is the same berry as black pepper allowed to ripen before picking, when it does not shrink like the black and the outer black husk or bran can be removed, making the grains white. White pepper is much the better for most cooking purposes; that is, for adding to dishes that are already cooked, as it does not show in dark specks, but black pepper is to be preferred for flavor; to be cooked in compounds which are to be strained afterward. **MIGNONETTE PEPPER**—Is black pepper crushed, not ground, that it may be cooked in sauces and soups and be easily strained out, being coarse. **LONG PEPPER**—An inferior sort of pepper sometimes used in pickling but now in little demand. It is not fit to grind, having an unpleasant flavor. It is used to some extent to adulterate ground white pepper and is the source of the offensive odor given out by some samples of white pepper when heated in cooking. Long pepper is the seed of a weed which grows along the water-courses in India. **CAYENNE PEPPER**—Red pepper pods and seeds ground; the small capsicums are the kind generally used, but there is a mixture of various sorts. The adulterating material is yellow corn meal, turmeric, mustard hulls, etc., but it is not difficult to get it quite pure from respectable merchants. **SPANISH SWEET PEPPERS**—A large kind of "bull-nose" pepper used green as a vegetable, stuffed and baked, or eaten raw, as a salad. **COLORING PEPPER**—In New Orleans, and Florida cities a sort of cayenne of very mild taste is used under the above name, principally in fish cooking. It is an article of regular sale in grocery stores, and occupies the same place in creole cookery that curry powder holds in that of other countries. It is mixed with creole boiled rice in sufficient amount to make the whole dish light red; a fish to be baked is laid open in the pan and perfectly covered with the red coloring pepper before cooking; it enters into jambalaya and into the fish stew known there by name of courtbouillon.



## PER

**PEPPER POT**—The native soup of the British West Indies, mentioned in song and story. It is a hotch-potch like the Spanish *olla podrida*, one song running to the effect that when made in camp, each soldier drops into the pot whatever he has been able to capture or obtain in any way, chickens, game, fresh or salt meats, and vegetables of all sorts; the special seasoning is a native sauce, *cassareep*, and plenty of chili pepper.

**PERCH**—“The ancients have not left us any hints as to how perch were cooked. The present practice over the Continent is to stew them in vinegar, fresh grape, orange juice, or other sour sauce; but, though this is certainly the common way in Italy, at the Lago Maggiore they are spitted in their scales, and basted while roasting with the same acid juice. In Holland butter is added. The finest perch is the zander, or giant perch of German waters. A recent writer declares that it is worth going all the way to Dresden to taste it.” The perch is one of the most abundant fresh-water fish on both sides of the Atlantic. Its name in French is the same as in English, it can scarcely, therefore, appear in any menu in disguise.

**PERDRIX, PERDREAUX** (Fr.)—Partridges; the latter term is applied to young birds.

**PERIGORD** (*ala*)—With truffles; name of a town in France famous as a truffle market.

**PERIGORD PIE**—A paté or raised pie of boned partridges and fresh truffles.

**PERIGEUX, SAUCE**—Truffle sauce, made of espagnole, meat glaze, white wine and sliced truffles. Meats served with this sauce are *a la Perigeux*. **PARISIAN RESTAURANT RECIPE**—And, being amongst my recipes, here is one for a sauce which is most delicious, and which, being of truffles, can be eaten with almost any dish. It is called *Sauce Perigeux*: Chop up some lean ham into small dice and mix it with an onion and shallot minced very fine. Fry this with some butter in a saucepan until the onion has browned the whole, when add a little white wine and let it simmer. Make some browned butter, mix the sauce with it, with an equal quantity of *bouillon* and shredded truffles. Let it simmer again until it becomes of the consistency of sauce. Pass it through a sieve and add as many truffles as possible, cut into slices, when the sauce will be ready for use.

**PERIWINKLE**—A sea snail of small size, cooked and eaten as a relish, cold, but does not enter into any compound dishes.

**PERRY**—The juice of the pear; pear cider.

**PERSILLADE** (Fr.)—Parsley sauce; a dish made green with cooked parsley.

**PERSIMMON**—A wild fruit of the Middle and Southern States; good but neglected; grows on trees of small dimensions. It has the shape and appearance of a small tomato, the color, however, is yellow when nearly mature and reddish brown when fully

## PHE

ripe; this state is not reached until after a slight frost. It is then a mass of very sweet pulp containing several brown seeds, the taste is musky, like the banana. While it is of but little value as fresh fruit it will make a pleasant sparkling wine. It is made into *Persimmon Beer* in Virginia in this way: A barrel with pine branches in the bottom, or straw if pine is not to be had, and a faucet, is half filled with ripe persimmons; a panful of the fruit mixed with bran or meal is baked until partly browned and added to the fruit in the barrel to heighten the flavor; the barrel is then filled up with water and allowed to ferment like cider. In a few days it is drawn off into another barrel and bunged tight or bottled, and the first barrel refilled with water eventually makes vinegar. Good domestic wine can be made without the baked fruit, and without sugar, a little yeast spread upon toast assisting the fermentation. **PERSIMMON BREAD**—The sweet pulp of persimmons rubbed through a strainer used to mix with corn meal instead of water, makes a sweet corn cake.

**PETTITOES**—Sheeps' feet, lambs' feet or pigs' feet. The common popular name of sheeps' pettitoes is sheeps' trotters.

**PETIT OR PETITE** (Fr.)—Small. **PETITS POIS**—small (young) green peas. **PETITS PAINS**—Small loaves, rolls. **PETITES FONDUES**—small souffles of cheese and eggs in paper cases. **PETITES MERINGUES**—Small meringues or egg-kisses.

**PETITS-CHOUX** (Fr.)—One of the three or four names attached to the hollow cakes popularly known as cream puffs when filled with cream. The *petits-choux* paste is employed for several purposes. (See *Eclairs, Profiterolles, Queen Fritters*.)

**PHEASANT**—“The pheasant has probably been more praised and more abused than any other game bird. Dr. Kitchiner says its rarity is its best recommendation, while Kettner says, if kept till the *fumette* is fully developed, it is beyond all other fowls. This is the point at which opinion divides. The



PHEASANT—FAISAN DE BOHEME.

pheasant requires long keeping to be eatable, and those who do not like 'high' game do not like the pheasant.” “Some people will stare with astonishment when we name boiled pheasant, yet the only pheasant we ever really enjoyed was boiled, and served with celery sauce.” **BOILED PHEASANT**—“When you want a superb dish

## PHO

a dish that will strike your guests with amazement and awe, *boil* a pheasant, and serve it with oyster sauce. I am aware that this sounds like a culinary heresy. Try it. I do not say you will abandon roasting, but I do say this—the recollection of that dish will haunt you for months, and you will not rest satisfied until you have it again before you.”

ENGLISH PHEASANT EN PLUMAGE—The head taken off with its feathers, also the rump with the long tail-feathers, both reserved while the pheasant is larded, roasted, placed in dish and plumage fastened in place with silver skewers. ROAST PHEASANT—Larded, slice of bacon tied on breast, butter and shallots inside, roasted; served with bread sauce.

PHEASANTS IN ENGLAND—Are regarded almost as domestic fowls, being protected as they are in game preserves and bred and thinned out systematically. Their flesh is light in color, and they are cooked in most of the ways suitable for poultry. French and other Continental *menus* most frequently mention Bohemian pheasants, or *faisans de Boheme*. FAISANS A LA SOUBISE—Braised pheasants covered with Soubise sauce. FAISANS A LA BOHEMIENNE—Pheasants stuffed with *foie gras*, truffles, etc., cooked in mirepoix; served in the sauce with truffles. FAISANS A LA FONTAINEBLEAU—The breasts are larded in a square. They are braised in white stock with lettuces and sausages, and served with the garnish and brown sauce. Pheasant pies and pheasant galantines, in the usual ways.

PHOSPHORUS PASTE FOR ROACHES—The following recipe for the destruction of cockroaches in bakehouses, etc., is efficacious: Mix 1 dram of phosphorus with 2 oz. of water in a stone jar; set this in hot water until the phosphorus is melted, then pour into a quart or half-gallon pan containing  $\frac{1}{4}$  lb. of melted lard. Stir up quickly, and put  $\frac{1}{2}$  lb. of fine sugar and  $\frac{1}{2}$  lb. flour made into a stiff paste. Make the paste into small balls about the size of small Spanish nuts, and put them about wherever you find the cockroaches, and fill up all cracks and holes with the paste. They will eat it and die by hundreds.

PICCALILLI—Mixed pickles.

PICKEREL—American lake-fish of the pike family, larger than a pike, and of first quality for the table; is cooked by broiling, boiling, frying, or baking.

PIECES MONTEES—Large decorative pieces of cooks' work of all kinds. “The *service a la Russe*, by some *gourmets* lauded to the skies, by others abominated as inartistic and unconvivial, has almost banished savory *pieces montees* from the dinner table. Save at a restaurant in Paris or St. Petersburg, we rarely see our food in its entirety. But there are certain *plats* which should be seen before they are eaten. Such is the *saumon a la Chambord*, surmounted by its forest of *hatelets*; the *dinde truffee*, and in particular the *poulet a la Marengo*, that glorious pyramid of fowl fried in oil—Napoleon's cook had no butter when his master returned from his famous victory,

## PIE

and was fain to use Lucea oil instead—eggs, sippets, and crawfish. Served *a la Russe* in fragments from an invisible entity, these historic *mets* would lose half their purport and significance.”

PIE—There is a marked dissimilarity between the English and American idea of pie. An English feast is scarcely complete without pie, and at a ball supper there will be a variety; but they are pies of meat and game, whereas the American pie in general is a sweet. A few hot pies of meat are in high favor here, such as chicken pie; but nobody ever thinks of ordering a cold meat pie. This is the saying of an English *gourmet* and expresses the national idea: A GRADATION OF PIES—“The best of all pies is a grouse-pie; the second is a blackcock-pie; the third a woodcock-pie (with plenty of spices); the fourth a chicken-pie (ditto). As for a pigeon-pie, it is not worthy of a place upon any table, as long as there are chickens in the world. A rook-pie is a bad imitation of that bad article; and a beefsteak-pie is really abominable. A good pie is excellent when hot; but the *test* of a good pie is: ‘How does it eat cold?’ Apply this to the samples above cited, and you will find I am correct.”—

RAISED PORK PIES—There are establishments in England where these are turned out by the ton, equaling the American pie bakeries, and are shipped to all parts; they are of all sizes but the greater number are of the small sort for retailing at the same average prices as American sweet pies. They consist of a case made of hot water paste, which consists of  $\frac{1}{4}$  lb. shortening to each pound of flour and  $\frac{1}{2}$  pt. hot water, stirred up at medium heat (not boiling) into a stiff, smooth dough and shaped by hand entirely, the outer wall being pinched and pressed upwards from the bottom. The cut meat and seasonings are then put in, the lid put on in a separate piece; the pie decorated and then baked. The difficulty of making occurs with the large sizes. Those who have attempted to make the article as a home-manufacture, know that the great difficulty is to get the crust sufficiently stiff to stand and keep erect with such weighty contents as are put inside, and without disastrous collapse. By a few deft turns of the hand, the palm being most used, the foreman, at our visit, encased the solid wooden “block” used for the purpose with an even outer casing of paste, until it “stood alone” on the withdrawal of the block, like a good silk dress, supported by its own inherent richness of material. Inside this the solid contents were then placed, the lid was put on, the line of juncture neatly pared off with an instrument which left an ornamental border; the flowered “chase-hooping” was passed round the circumference, to make surety doubly sure; the ornamental foliage or scroll work on the cover, with the heraldic arms and manufacturers' stamp was affixed, and the finished article was ready to be sent to the oven. The latter is kept at an evenly regulated temperature, maintained by a thermometer gague; and when the pie comes out brown, crisp, and erect, the work-

## PIE

man's anxieties are at an end. The better kinds of pies have a richer crust. (*See Paste.*) **RAISED FRENCH PIES**—Are often made in winter, as they will keep a week or two closely covered, and they are frequently sent, packed in a close tin box, for a considerable distance as a Christmas gift. These pies have standing crust or walls, and may be filled with game or poultry, previously boned, seasoned and stewed, and they are generally made very large. "Put the pie into an oven and bake until brown. The lid must be baked separately. When both are done, remove the bones and bread crusts from the inside of the pie, and fill with the prepared ingredients, which must be previously stewed in their own gravy, with the addition of bits of butter rolled in flour." (*See Paste.*) **AMERICAN PIE**—A Philadelphian claims that there are more pies eaten in his city than in New York. He says that Philadelphia makes about 45,000 pies per day throughout the year, which makes 315,000 pies per week, or 1,585,500 for the entire year. In a single day it uses for the average run of pies 40 tubs, 32 qts. each of fruit, 300 qts. of milk, 7 barrels of flour, 500 lbs. of lard, 400 lbs. of cheese, 60 doz. eggs, and various other ingredients in lesser quantities. The total output from all the large concerns is about 20,000 pies daily. Then there are hundreds of small bake-shops and each of them makes from half a dozen to several hundred pies, or altogether about 25,000 per day. This makes the total number about 45,000 per day, or 15,885,500 in a year. In New York one of the foremen of a large factory stated: "In our establishment we turn out every kind of pie so far discovered, but there are certain kinds that are staple. These are apple, mince, lemon, grape, raisin, plum, gooseberry, whortleberry, strawberry, peach, raspberry, pineapple, pumpkin, and custard. Apple, mince, lemon, pumpkin, and custard are the favorites. All our material is the best in the market, and we buy it in large quantities, always keeping our orders ahead." "How much material do you use daily?" asked the reporter. "In a single day we use about 100 dozen eggs, 850 pounds of lard, 12 barrels of flour, 600 quarts of milk, 2,500 quarts of fruit, and turn out about 7,000 pies, or about 50,000 a week and 2,600,000 a year. The output from the large concerns in the city will amount to 35,000 pies daily, and the bakers will turn out about 40,000 more, or 75,000 a day, 525,000 a week, and 27,300,000 per year, an average of about sixteen pies per capita." **YALE PIE**—Put three or four pounds of steak, seasoned with pepper and salt, into a medium-sized dish; cut in pieces two chickens, lay them on the steak, and over them put a dozen oysters, without the liquor, add six hard boiled eggs; pour in half a pint of strong ale; and cover the whole with fresh mushrooms and half a pound of neat's foot jelly; cover the dish with a good paste, and bake in a brisk oven. **VEAL PIE**—"Weal pie," said Sammy Weller, "is a werry good thing when it isn't cats and you know the woman wot made it."

## PIG

**PIGEONS (Fr.)**—Pigeons. The same in both languages.

**PIGEONNEAUX (Fr.)**—Young pigeons; squabs.

**PIGEONS**—“Pigeons, quails, and other dark-fleshed birds have the reputation of being a heating diet, which is probably correct. But, however that may be, one epicurean rule holds good with pigeons, which is, whatever recipes may be given to serve hot, in all forms they are better eaten cold. There are, in fact, only two orthodox ways of cooking pigeons, namely, in a baked pie, and in a boiled pie, or pigeon pudding.” **PHILADELPHIA SQUABS**—Have a great reputation and serve a good purpose as a substitute for game. Old pigeons are really good only in one way, that is, “jugged” or potted, which means cooked in a covered jar in the oven for several hours. **FATTENED PIGEONS**—Bordeaux pigeons may now be seen in the markets in boxes of 12, as large and plump as partridges. We cannot understand why the farmers of France are allowed to retain a monopoly in fattening pigeons for the table; surely there is an opening here for our own people. **BROILED PIGEONS**—Pluck, draw, singe, and truss your pigeons; beat them until flat, and warm in melted butter, seasoned with salt and pepper. When nearly cooked, remove the pigeons, sprinkle them with breadcrumbs and broil over a moderate fire until a good color. Dish up, covered with piquante sauce. **PIGEON AU RIZ AUX TOMATES**—Specialty. One of the special dishes of the Café de Paris, in the Avenue de l'Opéra, is *pigeon au riz aux tomates*, and this dish is prepared as follows: Sauter in butter two pigeons, add salt and 3 fine tomatoes cut in 4, pipped and peeled. Meanwhile fry in butter 2 finely minced onions, and when these are of a nice golden color add 200 grammes of picked rice. Continue warming your rice for 2 or 3 minutes, then moisten with a pint of clear bouillon; allow the whole to cook for 20 minutes, withdraw the pigeons, and add the rice. This dish should be served at once. **PIGEON A LA ZETLAND**—Cut the birds in half, steep in a highly spiced wine marinade, let them lie for 12 hours. The last hour place on the hot plate, so that they may be half cooked; then drain, wipe the birds dry, wrap in a vine leaf, drawing the stalk through the tip of the leaf, dip into a batter and fry. Garnish with fried parsley; brown gravy. **POTTED PIGEONS**—Bone the pigeons, stuff with veal and ham forcemeat highly seasoned; press the birds into deep, brown earthenware dishes, cover with butter well seasoned with mignonette pepper, mace and allspice. When the birds are cooked, lift them carefully out, and whilst hot press into oval pots. To dish, turn out on to dishes covered with lace paper; garnish with light endive, capers and pickled chillies. **PIGEON CUTLETS WITH GREEN PEAS**—Halves of pigeons simmered in butter, pressed flat until cold, trimmed to shape of cutlets, breaded, broiled; with green peas in the dish. **PIGEON ASPIC**—Stewed pigeons, meat pounded through a sieve, mixed with cream and yolks and seasonings over

## PIG

the fire. Layers of aspic jelly and layers of pigeon purée alternately in a mould, made cold, turned out and decorated. **PIGEON PIE**—Bottom of baking dish covered with thin beefsteak, halves of pigeon on that, hard-boiled yolks, forcemeat balls, mushrooms, thin slices of bacon, strong beef gravy, crust of pastry on top, baked 1½ hours. **STEWED PIGEON**—Partly fried in butter, slice of lean ham, mushrooms, stock, herbs, seasonings and wine, stewed together until the sauce is rich enough for gravy. **ROAST PIGEONS**—Cover young pigeons with vine leaves, wrap them up in bacon and roast for ½ hour. Serve with their own gravy, and garnish with water cresses. **FILETS DE PIGEONS A LA DUXELLE**—Breasts of pigeons coated with Duxelles sauce, breaded and fried; Provençale sauce and mushrooms. **COTELETTES DE PIGEONS AU FUMET DE GIBIER**—Breasts of pigeons breaded and fried, piece of bone stuck in to imitate a cutlet; game sauce. **PIGEON CUTLETS**—Are also made of the halves of pigeons boned, except the leg bone, which represents the cutlet bone, as above, with green peas.

**PIGEONS, WILD**—There are times in some parts of the country when immense flocks of wild pigeons settle down in the forest for a few days, and the people from the neighboring villages shoot them by thousands, glutting the market for a brief period. With a little experience it is easy to pick out the young birds, which may be roasted or broiled, and the heavier old ones should have long cooking in a gravy.

**PIG—HOW TO SERVE ROAST PIG**—“Of late they have got into a trick of serving up the roasted pig without the usual concomitants. I hate the innovating spirit of this age; it is my aversion, and will undo the country. Always let him appear erect on his four legs, with a lemon in his mouth, a sprig of parsley in his ear, his trotters bedded on a lair of sage. One likes to see a pig appear just as he used to do upon the board of a Swift, a Pope, an Arbuthnot. Take away the customs of a people, and their identity is destroyed.” **PEACH-FED PIG**—At a recent dinner, given by Lady Eardley, one of the most remarkable dishes was cold ham cut from a pig fed entirely on peaches, and imported from America. It was served with aspic jelly and truffles. **PIGS AND PARSNIPS**—There was nothing considered more delicate in the sixteenth century, nothing more odoriferous, than the flesh of young pigs fed on parsnips, and roasted, with a stuffing of fine herbs. **COCHON DE LAIT A LA SAVOYARDE**—Sucking pig stuffed with sausage-meat, rice, shallots, seasonings; served with little sausages, white sauce with wine and mushrooms. **COCHON DE LAIT A LA PERIGUEUX**—Stuffed with truffles, served with Perigeux sauce. **COCHON DE LAIT A LA CHIPOLATA**—Sucking pig stuffed with chestnuts and sausage-meat, served with Chipolata garnish. **COCHON DE LAIT EN GALANTINE**—A boned pig, stuffed, decorated.

**PIGS' FEET**—They are put up in packages of all

## PIN

sizes in spiced vinegar, making a convenient and very acceptable article of hotel provision all through the season of cool weather. Generally served cold, very often breaded and fried, or broiled, or stewed in white sauce thickened with yolks. **PIEDS DE PORC A LA STE. MENEHOULD**—Pigs' feet breaded and fried. **BONELESS PIGS' FEET**—Can be bought in cans. They are capable of being cooked in ornamental or shapely ways by being heated and pressed first.

**PIKE**—Fresh-water fish common and plentiful in America. The pike has been honored with the most elaborate cooking in France, pike à la Chambord being an artistic dish. There are many better fish than the pike, however, and it makes only a good ordinary fry or broil at a moderate price in this country. **BROCHET A LA REGENCE**—“The pike was cooked for 2 hours in strong gravy and 3 bottles of champagne; the stuffing was of pounded crayfish and whiting, and the pike was also covered an inch thick all over with the same, the head and eyes being marked out with chopped truffles, and the body covered with ‘bracelets’ of truffles and crayfish tails, with rosettes of filleted sole. Bunches of eel-cutlets were not wanting, nor pyramids of mushrooms, nor oysters, nor carps' tongues and milts, nor ten of Carême's never ending skewers, fitted out with the same garnitures; and then you behold *le brochet a la Regence*, which some miserable plagiarists had the audacity to put in a *menu* opposite a dish of small fish!”

**PILAU, PILLAU, OR PILAF**—Turkish dish of rice and butter, with or without meat or tomatoes or other additions, generally, however, having mutton cut in dice, and a flavoring of fried onions.

**PILCHARD**—English sea fish like a herring.

**PILOT FISH**—So called from its being the fore-runner of the shark. The appearance of pilot fish around a vessel is always followed by the appearance of the white-bellied monsters. Pilot fish are captured for market and cooked by frying, broiling and baking.

**PIMENTO**—Allspice.

**PINON NUT**—Mexican nut like the pistachio, about the size of a beech nut. Sold in most city fruit stores.

**PINEAPPLE**—The pineapple is grown abundantly in the Bahamas and all the West India islands and is cheap in all American markets. **CANNED PINEAPPLE**—Is a favorite supper fruit; it is compote of pineapples ready prepared. **GRATED PINEAPPLE**—In this form it is used in pineapple ice cream and pineapple sherbet. See *Ices, Sherbets*. **PINEAPPLE PIE**—An open pie or tart with grated pineapple and sugar for filling. **PINEAPPLE CREAM PIE**—Grated pineapple mixed with powdered crackers and custard mixture, baked in a crust, not covered. This fruit, can be used in all the principal ways same as

## PIN

other fruits, in tarts, marmalade, jelly and preserves. (See *Apples, Apricots.*)

**PINTADE** (Fr.)—Guinea Fowl.

**PIQUE** (Fr.)—Larded with strips of bacon or tongue, truffle, mushroom stalks, etc. **FILET DE BŒUF PIQUE**—Larded fillet of beef.

**PIQUANT SAUCE**—Brown sauce made piquant by adding chopped shallots, little vinegar and pepper, boiled a few minutes, chopped capers and gherkins added, and meat glaze if only ordinary brown sauce be used.

**PISTACHIO NUTS**—Much valued in pastry and confectionery for their pea-green color and almond flavor. The nut is gathered in the green state. It is about the size of a filbert, is the seed of a tree which grows in Italy and the East. Is generally found in the Italian fruit stores ready shelled, but has a reddish husk which is removed by scalding, like almonds. The price varies as the crop sometimes fails, but a common price is about 40 cents a pound. While the flavor is delicate it is weak and needs the addition of almond flavor to make it complete. **PISTACHIO ICE CREAM**—Pounded pistachios and almonds pounded, some spinach juice or safe vegetable green coloring to heighten the color, (which, in whatever these nuts are used, should always be green), glucose, sugar and cream frozen. **PISTACHIO FRITTERS**—Chopped pistachios in twice their weight of sweet fritter batter, dropped by spoonfuls in hot lard and fried—these can be made green fritters by adding spinach green. **CREME DE PISTACHES**—Pistachio ice cream. **PETITES MERINGUES AUX PISTACHES**—Kiss meringues sprinkled with chopped pistachios and filled with whipped cream. **BAVAROIS AUX PISTACHES**—Bavarian cream, green, with pounded pistachios and almonds, sprinkled over when turned out of mould with chopped pistachios. **PETITS CHOUX EN GIMBLETTES**—Cream puffs like jumbles, that is, in rings, dipped in syrup, then in chopped pistachio nuts and sugar. **PETITS PUIXS AUX PISTACHES**—Little wells of pastry; i.e., puff paste tartlets, brushed over with syrup, covered with chopped pistachios and sugar and filled with whipped cream. **GATEAU DE PISTACHES**—Pistachio cakes made in all the same ways as almond cakes. (See *Almond.*)

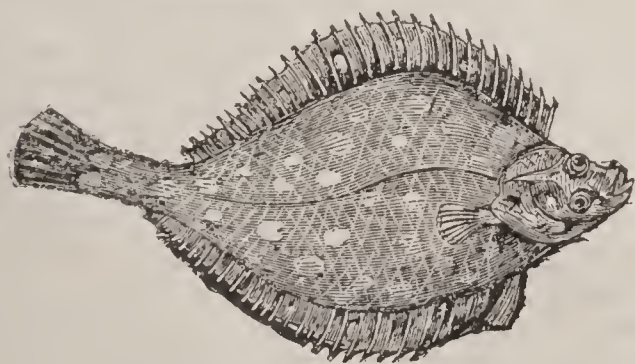

PLAICE—PLIE.

**PLAICE**—An English flat-fish, larger than a flounder, distinguished by yellow spots on the back.

## PLA

“Plaice, to be eaten in perfection, should directly it is caught be cleansed, its head cut off, and then be hung up by the tail, and sprinkled with salt, and left to dry for about twelve hours; if for filleting, the fillets should then be removed and laid in a marinade of lemon-juice, a few drops of oil, pepper, salt, shredded onion, and parsley, for two or three hours. The fillets must be wiped perfectly dry on a clean cloth before using. Treated in this way they lose almost entirely the watery, wooly taste so often complained of.”

**PLANTAIN**—A variety of banana, less sweet than the banana common in the markets and better suited to be baked with sugar.

**PLATE**—At the sale of a collection of old plate, which took place a few days ago at a country house in Bedfordshire, the extraordinary price of eighty-six shillings per ounce was paid for a pair of old English sconces, date 1718. Nearly as much was obtained for a true Queen Anne loving cup, with double handles and cover, dated 1713. A quaint old heater, with grid-iron, dated 1679, realized no less than sixty-six pounds. It is clear that the prevailing “depression” does not in the least affect the current value of objects of art, if they are really of genuine merit. **THE ROYAL PLATE**, which is probably the finest in the world, is usually kept in two strong-rooms at Windsor Castle, and is valued at two millions sterling. The gold service, which was purchased by George IV from Rundell and Bridge, dines one hundred and thirty persons; and the silver wine-cooler, which he bought about the same time, holds two men, who could sit in it comfortably. It is enclosed with plate-glass, and is splendidly “chased.” **THE CLEANING AND TREATMENT OF PLATE**—The best Paris whiting (perfectly clean and free from grit), moistened with spirit or water until about the consistency of cream, should be smeared on the article and lightly rubbed off with a soft chamois or wash-leather. The ornamental parts, where it cannot be rubbed off, brush briskly when dry. Polish with a rouged leather (a little rouge should be placed on the leather from time to time, not on the article); afterwards rinse with hot water, in which a little soap has been dissolved, and carefully wipe quite dry with a clean leather. **FROSTED SILVER**—Use only whiting and spirit, no rouge. **GILT WORK**—Wipe only with a rouged leather; if badly tarnished, moisten with a little spirit. Leathers for cleaning plate should be kept dry. When a leather is washed, it should be rinsed in a weak solution of soap and water (water alone would make it hard); and when dry, pulled and rubbed till it becomes perfectly soft. Plate after use should, if necessary, be washed with hot water and soap, and wiped over with a leather before it is put away. Plate keeps its color longest in a dry place, free from gas and other fumes; and, if cleaned according to above instructions, will last much longer than if cleaned in any other way. In the case of Britannia metal and nickel silver goods (not silver-plated), the plain sur-

## PLA

face should be cleaned with polishing paste, and the ornamental parts brushed with whiting (as above directed), and finally polished with a leather and dry whiting.

**PLATS**—(Fr.)—Dishes of meats, etc. **PLATS DU JOUR**—Dishes of the day; a few prepared dishes for dinner which one may find at the best restaurants, besides the unprepared dishes which may be ordered from the card.

**PLATEAU**—The central ornament of a dinner table; sometimes it is a mirror laid flat in imitation of a lake bordered with moss and flowers; sometimes it is a raised bank of flowers; at other times a pyramidal device or a temple.

**PLIE** (Fr.)—Plaice, a fish.

**PLOMBIERES ICE**—A mixture of ice cream and candied fruits, named for a place. (*See Ices.*)

**PLOVERS**—The best plovers are the golden plovers. They were the first birds that were eaten without being drawn, and they are still dressed in this way. **BROILED PLOVERS**—Broiled plovers are very good as a supper dish. They should be simply broiled as they are, kept well buttered while cooking, and, when ready, served on slices of fried bread. **ROAST PLOVERS**—Plovers should never be drawn, but wrapped up in slices of bacon and roasted. Lay some pieces of toast in the dripping-pan, and serve



PLOVER—PLUVIER.

the plovers on them. **CROUSTADES OF PLOVER A LA PROVENCALE**—Plovers in brown sauce with garlic, mushrooms, white wine, parsley, served in cup-shapes of fried bread. **FILETS DE PLUVIERS AUX CHAMPIGNONS**—Breasts of roasted plovers with croutons spread with the trail, and mushrooms in game sauce. **FILETS DE PLUVIERS A LA LUCULLUS**—Fillets of plovers covered with forcemeat and served in a border of toasted bread, with a thick purée of plovers piled in the center and game sauce around. **POTTED PLOVERS**—Boned plovers with raw game forcemeat packed in a jar with seasonings, wine and essence made from the bones, cooked in the oven. Served cold.

**PLOVERS' EGGS**—Plovers' eggs have, however, a far higher reputation than the birds themselves. They are delicious little morsels hard-boiled; they are incomparable in a salad or sandwich; and most admirable of all set like large opals in aspic jelly. "Plovers' eggs are generally eaten hard, and

## PLU

require seven or eight minutes to cook. They are often used as border for mayonaise salads, or dished up on a rice-stand and garnished with aspic jelly. They are also served in their shells and dished in a nest of moss. In the latter case slices of brown bread and butter should be handed with them. We have noticed this spring that ready-boiled plovers' eggs appear in the poulterers' windows—price 8 cents each." **WAYS OF SERVING**—Plovers' eggs are best *au naturel*. Some people prepare them in various sauces and gravies, or set them in aspic jelly; but simply hard boiled—they should boil ten minutes—and served either hot or cold (the last for preference), in a napkin, in their shells, or else shelled and prettily ornamented with watercress or parsley, they are more appetizing than when cooked up *a la Bechamel, a la tripe, en aspic*, etc. **SUBSTITUTES FOR PLOVERS' EGGS**—When the demand for pheasants' eggs begins to slacken, they might take the place of plovers' eggs. For the table they are very fine eating. The young of the black-headed gull is excellent eating. Its eggs resemble crows' more than plovers' eggs; but vast quantities of them are sold for plovers' eggs.

**PLUCHE**—Of green herbs for soups and stews; finely cut sorrel, chervil, parsley, etc.

**PLUCK**—Common popular name of the heart, liver and lights (lungs) of small animals as exposed for sale by the butchers as lambs' pluck, etc.

**PLUMS**—A considerable number of stone fruits are included in the general name of plum, varying from the large egg plum and greengage to the damson in size and appearance. All the ways of cooking and using apricots and most of those named for apples can be employed suitably for plums in some of their varieties. The greengage is especially a choice fruit for the compote dish, and its color, to contrast with the orange yellow of the apricot, gives it a particular value in decorative pastry work. (*See Apples, Apricots, Greengage, Pears, Peaches, Cherries.*)

**PLUM PUDDING**—Peculiar to Christmas in this country, as *crepes* and pancakes are to Shrove-tide elsewhere. It has been an institution in Britain for centuries, but in olden times was a porridge, a sort of mincemeat, and was eaten before the meats instead of after. There is a story of a late day of a great Englishman abroad who, having distinguished guests to dine with him on Christmas, decided to surprise them with the treat of an English plum pudding, and accordingly instructed his French cook how to make it. But he forgot to tell him the ingredients were to be tied up in a bag, so when the pudding was ordered in the cook with a string of assistants marched in with a procession of soup tureens holding what should have been the pudding. The mixture when prepared had been stirred into the great pot of boiling water and made into soup. **SAMPLE RECIPE**—There are a score or two of different recipes for making plum pudding; for a good

## PLU

sample see *Christmas Pudding*. This is symbolical: **THE PUDDING OF THE THREE KINGS**—Is a very rich plum pudding, made from the old-fashioned concomitants. A basin is buttered, lined with a thin suet crust; then the pudding mixture is put in to half fill the basin. This is followed by a rich custard perfumed with orange flower water; a paste cover is put on, and the whole steamed for from 6 to 8 hours; turn out and serve with brandy sauce. The spices and good things represent the gifts of the three kings of Cologne, who were said to be the wise men of the Star of Bethlehem fame; the paste is the casket enshrining the treasures. **A PLUM PUDDING**— $\frac{1}{2}$  lb. each suet, currants, sugar,  $\frac{1}{4}$  lb. each citron and candied orange peel, 6 oz. flour, 2 oz. breadcrumbs,  $\frac{3}{4}$  lb. raisins, 1 teaspoon ground cinnamon,  $\frac{1}{2}$  nutmeg, 1 lemon rind and juice, 1 glass brandy, 4 eggs, little salt; boiled 5 or 6 hours.

**PLUM CAKE**—Usually called fruit cake. With a pound cake mixture first prepared as a base, any desired amount of fruit may be added with or without spices, the color of the cake when done will be according to the spices and fruit contained. (*See Dundee Cake*.) **GOOD PLUM CAKE**—Is made of 1 lb. butter, 1 lb. brown sugar, 9 eggs,  $1\frac{1}{4}$  lb. flour, 1 lb. currants, 1 lb. stoned raisins or seedless raisins chopped,  $\frac{1}{2}$  lb. citron, 4 oz. almonds blanched and split, nutmeg, grated lemon rind, 1 glass whiskey; baked in a mould lined with buttered paper.

**PLUVIERS (Fr.)**—Plovers.

**POACH**—To cook in a pocket or pouch; to cook in a very little water. **POACHED EGGS**—Cooked in a shallow pan of water in rings—muffin rings—which keep them in shape, or, cooked in more water which is made to rotate in the pan by stirring before the egg is dropped in, which carries the egg while the outside cooks in good shape. **POACHED QUENELLES**—Small balls of delicate forcemeat are poached in little broth, to be taken up easily at the right moment. Sometimes the surfaces of large quenelles are decorated and must be poached without the decoration being covered.

**POCHE (Fr.)**—Poached. **ŒUFS POUCHES**—Poached eggs.

**POELE**—Same thing as *mirepoix*, except the color. Poêle is white or colorless broth of bacon and ham with vegetables, used to boil chickens, sweetbreads, etc., in instead of water.

**POIRES (Fr.)**—Pears.

**POIREAUX (Fr.)**—Leeks.

**POIS (Fr.)**—Peas.

**POISSON (Fr.)**—Fish.

**POISSONIERE (Fr.)**—Fish-kettle with drainer in the bottom.

**POITRINE DE VEAU (Fr.)**—Breast of veal. **POITRINE DE VEAU ROTIE**—Plain roasted; brown sauce. **POITRINE DE VEAU A LA PRINTANIERE**—Breast of veal boned, stuffed, rolled up, braised; served with garnish of spring vegetables.

## POM

**POIVRE (Fr.)**—Pepper.

**POIVRADE SAUCE**—A peppery sharp sauce, brown. (1) Espagnole with vinegar and broken pepper-corns boiled in it, and a spoonful of wine. (2) Carrot, onion, salt pork in dice, pepper-corns bruised, bay leaf, parsley, thyme; all fried in butter; drained of butter; vinegar and brown sauce added, or, if no brown sauce, some brown butter-and-flour thickening and water; simmered, strained.

**POKE WEED**—A tall, showy American wild-plant which bears purple berries. The young leaves are gathered in spring for tender greens. The berries are used for domestic dyes.

**POLENTA**—Italian corn-meal mush or porridge usually seasoned with grated cheese, butter, or tomato sauce, or all of them. It is treated in many ways the same as macaroni, being baked with cheese mixed in and on top. Polenta, or mush, is also made of chestnut flour and of wheat farina. **POLENTA PUDDINGS**—Same as American corn-meal puddings; hot mush with syrup, butter, eggs, fruit, cream; in several varieties. **POLENTA EMMANUEL**—Boil 1 teacupful of Indian corn-meal, stirring till thoroughly boiled; mix with, first, a small pat of melted butter and grated Parmesan cheese; serve very hot with a rich gravy flavored with tomatoes, and with roast larks or other small birds on top.

**POLONAISE (a la)**—In Polish style.

**POLPETTI**—Italian croquettes of minced meat with cheese and other seasonings; fried.

**POMMES (Fr.)**—Apples.

**POMME-DE-TERRE (Fr.)**—Earth-apple; the potato. The full name is seldom used, and whether the word *pomme* in a bill of fare stands for apple or potato is to be judged from the context. **POMMES NOUVEAUX**—New potatoes.

**POMEGRANATE**—A southern fruit of little utility, sufficiently plentiful in the southern markets; the fruit, however, is curious and peculiar and the subject of frequent mention in ancient books, while the small tree which bears it is a most charming ornament to the gardens and pleasure grounds where it grows, bearing a profusion of showy blossoms in April and May. The fruit is a pulpy, many-seeded berry, the size of an orange, with a hard, brown shell. It is pink or red inside like some varieties of oranges. **POMEGRANATE WATER-ICE**—Juice of pomegranates strained through a seive and the pips excluded, an equal quantity of strong sugar-syrup or glucose added, little lemon juice, orange rind, color to make it pink; frozen.

**POMEGRANATE MELON**—Often called *the* pomegranate. It is a tiny green-rind melon, mottled like the pie-melon, and not larger than an orange. Inside it is pink with abundant small seeds, closely resembling the pomegranate. Although pleasantly flavored as a melon its small size precludes it from being grown except as a curiosity.

## POM

**POMPANO**—Choice southern fish from 1 pound to 4 or 5 pounds in weight; shaped like the sunfish, or “pumpkin-seed fish,” with very small scales, steel-gray color. It has a fine nutty flavor, which is best brought out by broiling. Served with *maitre d’hotel* butter, lemon, fried parsley and fried potatoes.

**PONCHE** (Fr.)—Punch.

**POP-CORN**—A small variety of Indian corn; the grains burst and turn inside out when parched. There is a great difference in corn, and those who prepare it for sale test every sample in the popper before buying. It has to be kept a year before thoroughly dry. A bushel of shelled corn will make nearly 4 barrels of popped corn. **POP-CORN BALLS**—If the corn is to be worked into balls, a mixture of sugar, glucose and gum is poured over it, a handful is taken up and pressed into shape like a snowball. The red pop-corn balls are colored with thin cochineal syrup on the hands of the operator. **POP-CORN CAKES**—If pop-corn cakes are to be made, the corn is moistened with hot syrup boiled to the crack, pressed out into sheets, cut into sections and wrapped in transparent paper. At the Centennial Exposition the company received \$7,000 for the exclusive right to sell pop-corn. **CANDIED POP-CORN**—Is made the same way as comfits and sugared almonds by stirring it over a gentle fire in a candy-kettle, pouring syrup over it from time to time till it becomes lightly coated, the coloring being in the syrup. **GROUND POP-CORN FOR BREADING**—Croquettes egged and breaded with ground pop-corn have an appearance like snow covering a brown surface, as the pop-corn does not take color readily.

**POPOVERS**—Domestic name for a very light muffin made of 2 eggs, 2 cups milk, 2 cups flour, salt; a tablespoonful or two of melted butter may be added at option, but is not essential. The eggs whipped light are mixed with the milk and flour, the batter baked in buttered cups. The puffs rise high and hollow. Hot for breakfast. (See *Albany Cakes*.)

**PORGIES**—Small fish abundant in New York markets.

**PORK**—Roast pork should, like lamb, be well cooked, carefully and regularly baked; onion and apple sauce served in separate tureens. **LEG OF PORK**—Laid in salt for 4 days, boiled until nearly done, baked to finish in a pan with stock and chili vinegar; gravy made in the pan. **PORK CHOPS, APPLE SAUCE**—Chops breaded and broiled, paper frills put on ends of the bones, to ornament and to handle them at the table by; apple sauce in the dish, and chops around. **PORK COLLOPS**—Neat slices of cold roast leg of pork seasoned, broiled; served with mixture of onions and apples stewed together with wine. **PORK FRITURE**—Salt-pork slices soaked in skimmed milk 8 hours, egged, rolled in flour and fried. **SELLE DE PORC FRAIS**—Saddle of fresh pork. **GIGOT DE PORC A L’ALLEMANDE**—Leg of salt pork boiled, with stewed red cabbage, carrots and tur-

## POR

nips, and poivrade sauce. **CARRE DE PORC A LA REMOULADE**—Roast rack of pork, with remoulade sauce with chopped pickles. **PETIT SALE AUX CHOUX**—Salt pork with cabbage. **COTELETTES DE PORC A LA ROBERT**—Pork chops with Robert sauce. **COTELETTES DE PORC A LA BOLOGNAISE**—Breaded pork chops with grated Parmesan mixed with the crumbs, fried; served with a garnish in center, of mushrooms, tongue, and short pieces of macaroni in tomato sauce. **FILETS DE PORC A LA MARECHALE**—Are pork tenderloins cut in round slices, breaded and broiled; served with potato balls. **FILETS DE PORK A LA HANOVERIENNE**—Pork tenderloins larded braised and glazed, dressed in a circle on dish with stewed white pickled cabbage in center, and brown sauce. Can have spinach or apple sauce instead of cabbage, and name according. **ESCALOPES DE PORC A LA LYONNAISE**—Pork tenderloin cut slantwise in oval slices, breaded, fried, dressed in a circle, covered with Soubise purée of onions, bread-crumbs on top, and browned. **ESCALOPES DE PORC A L’INDIENNE**—Tenderloin slices with curry sauce. **BROILED PORK TENDERLOINS**—(1) Split open, flattened, seasoned with salt, pepper, powdered sage; broiled; served with a sauce made of the gravy from fried sausages. (2) Served with fried onions. (3) Served with fried apples. (4) Served with butter and fried sweet potatoes. (5) Served with *maitre d’hotel* butter and potato chips. **ENTRECOTE OF PORK**—Pork steak stuffed, rolled up and roasted or braised; onion sauce. **GRENADINS OF PORK**—Same as grenadins of veal. **POTTED PORK**—Pork tenderloins cut small and pounded in a mortar, seasoned with salt and pepper, and sage and rosemary, or with spiced salt; mixed with some hot butter; packed in a jar and baked in slow oven; pressed down again when done, and grease drained off; eaten cold or in sandwiches. (See *Backbone, Head Cheese, Echinee, Pig, Sausages*.)

**PORPOISE**—Sea-fish of the smooth-skinned sort. “Schools” of porpoises sport in shallow water near the shore and sometimes in advance of a vessel for days at a time. They are captured for their oil. **PORPOISE STEAK**—“The new delicacy in favor beyond the Atlantic is porpoise steak. The world is overhauling its *menu*, and hunting up new dishes. Some one has suddenly thought of the porpoise, or, as the Americans call it, the sea-hog, and the result is a flesh-food described as exquisitely tender and tasty, with a grain as red and juicy as the best cut in a fillet-steak or sirloin. In flavor the porpoise resembles venison, and we are pretty sure to hear of it in London before long. If it is as good as reported, it should certainly take its place on the *menus* of marine hotels.” **DOLPHIN MEAT**—“According to a Transatlantic paper, the flesh of the porpoise is sold in Philadelphia as a substitute for beef, under the name of ‘dolphin meat.’ It is described as red, juicy, tender, fine-grained, and of very pleasant flavor.”—“In the fifteenth century porpoises were brought whole to table, and were eaten with mustard.”—



## POR

**PORPOISE ON THE COALS**—An ancient bill of fare found in the British museum mentions among the courses of a grand dinner "Porpoise with Peas" and "Porpoise Roasted on the Coals." There is a record of Henry III ordering the sheriffs of London to purchase for him 100 pieces of the *best* whale, and two porpoises. Henry VIII gave occasion for some witticisms by his fondness for this archetype of obesity; if it was too large for a horse-load, an extra allowance was made to the purveyor. In Norway a delicate caviare has been made from its eggs.

**PORRIDGE**—Proper name of "mush," which is but a provincialism. Made of oatmeal, cornmeal, graham meal, fine hominy or grits, ground rice, farina, graham farina, cracked wheat, rolled oats, etc. Some of these need to be soaked in water for some hours before cooking. They are all made into porridge by simply boiling in the requisite quantity of water, and best if in a double kettle or *bain-marie*.

**PORTERHOUSE CUT**—The best part of the loin of beef; the portion between the last rib and the hip bone. It is an American specialty, the name having originated in a hotel known as the Porter House.

**PORTERHOUSE STEAK**—Steaks from the porterhouse cut of beef. They consist of a portion of the fillet or under-cut, a portion of the top loin; portion of the spine bone and little of the flank being therefore the best of the beef. The steaks are small and narrow at the rib end, and broader towards the butt.

**POSSUM**—See *Opposum*.

**POTAGE**—See *Soups*. Potage, like English potage, signifies a thick soup, and *consomme* a thin or clear. Soup includes all descriptions.

**POT-AU-FEU**—Fire pot; the French national soup. **POT-AU-FEU BOURGEOIS**—"The French national dish is unquestionably the world-famed *pot-au-feu*, and there is hardly a Frenchman, rich or poor, who does not partake of that savory and nourishing preparation at least once a week. This soup, simple as it is, cannot be made properly anywhere but in France, and the assertion, strange as it seems, will be corroborated by all who have tasted it. The meat that has been used to make the soup is eaten afterwards, in conjunction with the vegetables that were boiled in the pot. The *pot-au-feu* is made generally in an earthen vessel, used only for the purpose. The meat is put in cold water with a little salt, and set on the fire. When the liquid begins to boil, the pot is drawn back, and the contents allowed to simmer as gently as possible for 4 hours. The quantity of meat employed is 1 lb. to 1 qt. of water. When the ebullition begins, care must be taken to remove all the scum that rises to the surface. The vegetables consist of carrots, turnips, onions, leeks, celery, and cabbages. A brown onion (*oignon brule*) boiled in the pot improves the flavor as well as the color of the soup. A few minutes before serving the soup the meat is taken out of the pot, and the broth is

## POT

strained through a very fine strainer into the soup-tureen, which should contain some very thin slices of stale bread." **CROUTE-AU-POT**—"Such is the recipe for the *pot-au-feu bourgeois*, as it is served in every small French family; but if required for a dinner *recherche* it changes its name on the *menu* and is called *croute-au-pot*. In this latter case a fowl and a knuckle of veal are added to make the broth; the vegetables are cut of an even form, and the slices of bread are replaced by the crust of 2 or 3 French rolls cut the size and shape of half a pigeon's egg. These crusts are fried in some of the clear grease skimmed from the top of the broth, and are handed round on a plate when the soup is served." **POULE-AU-POT**—"King Henry IV was alluding to the *pot-au-feu* when he said, in his manifesto to the people of France, that if he lived long enough, his ambition was to see every peasant in his kingdom prosperous enough to be able to have a fowl in his pot every Sunday."—"Experienced housewives insist that any contact with metal is sure to spoil the flavor; it is the earthen pot, well seasoned, on which everything depends. In this earthen pot, then, the French cook will place only the best and freshest meat, the tenderest and most delicate vegetables; onions and pepper, those stumbling-blocks of the inexperienced cook, are eschewed altogether, a young leek supplanting the onion in the *pot-au-feu*, at least with dainty feeders. No single flavor should predominate."

**POTATO**—"The potato is not in France the homely esculent that it is on this side the ocean. There are as many ways of preparing it as there were in Goldsmith's time of cooking a nettle-top. Potatoes are only admitted *en robe de chambre*, that is to say, in their jackets, to the midday meal, and then on unceremonious occasions. They chiefly figure at *dejeuners intimes*, or *dejeuners* taken at restaurants where the *bifteck aux pommes* and *la cotelette a la puree de pomme de terre* are in great favor."—**POMMES GEORGETTE**—Specialty of M. Joseph, of the Café Paillard. "These are potatoes *en surprise*. I take a potato and hollow it out, filling the hollow with a salpicon of shrimp-tails drenched in a bisque sauce made of the heads and pounded bodies of the shrimps. Then I cover the potato up and bake it in cinders. It comes to table baked and burnt. I called it Georgette, because I created it on the day of the first night of Victorien Sardou's play of that name at the Vaudeville Theatre. Sardou's play ran only ninety nights. My Georgette has had an unlimited run." **POMMES DE TERRE AUX ŒUFS**—Specialty. "For serving with cold meat, etc., potatoes cooked after the following recipe, given me by a Parisian chef, are very suitable. The recipe is for *pommes de terre aux œufs*. Put a good-sized lump of butter into your pan; as soon as it is hot, brown some onions in it. Cut some cold potatoes, which have been boiled in their skins, and afterwards peeled, into slices. Throw these slices into the pan. Spread over them the well-whipped yellow of two eggs. Salt, pepper,

## POT

and serve when your potatoes have taken a nice brown color on each side." **POMMES HONGROISES**—"I discovered these to be the *pommes a la lyonnaise*—slices of boiled potato fried with onion and baked in the oven. At this restaurant, however, the potatoes are sprinkled with a little grated cheese before they are put into the oven. A decided improvement. The garnish of minced parsley remains, of course, indispensable." **POMMES A LA MAIRE**—Specialty. Potatoes cut in rounds, boiled until barely done in salted water, drained, put into cream which has been reduced to a state of condensed richness by evaporation in a steam vessel. "It is the reduction of the cream to one-half its volume that is the special and essential feature of the recipe for potatoes *a la Maire*, and it is to this special treatment they owe that excellence which constitutes them the leading specialty of Maire's Restaurant." **HASH CREAM POTATOES**—Hash cream potatoes is an acceptable breakfast dish if hot potatoes are used; but cold potatoes have a disagreeable flavor, which spoils the dish. Cut three warm boiled potatoes into small even pieces, add them to half a pint of boiled cream and a saltspoonful of salt. Put the mixture into a small tin or baking dish; strew lightly over the top a thin layer of bread-crumbs or grated cheese; add a pat of butter, and bake a delicate brown. **ANNA POTATOES**—A specialty at Delmonico's renowned New York restaurants. Cut very thin slices right across the largest potatoes; lay the slices in flat layers on a small plate that will bear the heat of the oven. Spread fresh butter freely over the potatoes; then add another layer, and so on until the potatoes are about four inches high. "Delmonico's" recipe gives  $\frac{1}{2}$  lb. fresh butter to 2 large potatoes. Bake until the potatoes are tender, about half an hour, in a quick oven. **POTATOES A LA BONNE BOUCHE**—Slice some boiled potatoes; chop a blade of shallot, also a little parsley very fine; place them in a stewpan with 3 oz. of butter and a pinch of mixed sweet herbs; let simmer slowly 5 minutes, then put in the potatoes, sprinkle some seasoning over them, and let simmer gently for 10 minutes, occasionally stirring to prevent burning. Just before serving squeeze the juice of 1 lemon over the potatoes. **POTATO CROQUETTES**—Steamed dry potatoes with salt, little butter and yolks added; mashed; rolled to shape of bottle corks, egged, rolled in cracker dust, fried in hot lard; served with fish and entrees. **POTATOES A LA DUCHESSE**—(1) Same preparation as potato croquettes; made into thick roll, sliced off, slices on a floured board patted into leaf shapes, marked with back of a knife, washed over with egg, baked light color; served with fish or entrees. (2) Large cold boiled potatoes sliced, cut with a wetted tin cutter, salted, egged over, baked. **POTATOES A LA VICTORIA**—Same preparation as potato croquettes made into round balls, egged over, baked light color in quick oven. **POTATOES A LA GASTRONOME**—Potatoes cut raw into shape of bottle corks with a tube cutter, boiled barely done in salted water, drained

## POT

out, finished by frying in hot lard quickly, light color, dredged with fine salt and parsley dust. **POTATOES A LA MONACO**—Potato cut raw into shape of silver half-dollars or little thicker, cooked same as *a la gastronome*. **POTATOES A LA JULIENNE**—Cut raw into very fine shreds like straws, fried quickly in hot lard, dredged with salt and parsley dust. **CURLY POTATOES**—Cut raw with a kind of paring machine into long spirals, fried by throwing into kettle of hot lard; salt and parsley dust. **POTATOES A LA SERPENTINE**—An instrument like a cork-screw with auger in center goes through a potato and makes a cord of potato like the strand of an untwisted rope; these smooth spiral cords are fried as usual; served as garnish to fish or entrees. **POMMES A L'ANGLAISE**—Boiled in their skins, peeled, cut in quarters if large, shaken up in a hot dish with soft butter, salt and parsley dust; sent in hot with the butter poured over. **POMMES DE TERRE EN CHEMISE**—Potatoes in their jackets. **POMMES A LA MAITRE D'HOTEL**—Boiled, cut in quarters in hot *maître d'hôtel* sauce. **POMMES A LA CREME AU GRATIN**—Boiled sliced in white sauce with Parmesan cheese, bread-crumbs on top, browned in the oven. **POMMES AU LARD**—Stewed potatoes with bits of bacon in the sauce. **POMMES A LA CREME**—Potatoes in cream sauce; same as "hash cream potatoes" above. **POMMES SAUTES**—Boiled potatoes cut in slices, fried in a frying pan with butter or sausage fat, salt, white pepper, no onions. **POMMES A LA MACAIRE**—"Shoestring" fried potatoes, made by cutting potatoes raw into one unbroken string; there are machines for it. **POMMES SOUFFLEES**—Baked in their skins, the potato mixed with butter, Parmesan cheese, eggs, salt, put back into the skins, set on end in a pan and browned. **POMMES FARCIES A L'ITALIENNE**—Like soufflées preceding, but the potato pulp mixed with rice and cheese. **POMMES NOUVELLES A LA CREME**—New potatoes in cream sauce. **POTATO QUENELLES**—The potato croquette preparation in small balls, rolled in plenty of flour and fried quickly before they burst, as they will if the fat be not hot enough. **PUREE DE POMMES A LA MARIA**—Mashed potatoes quite soft with cream and butter. **POMMES EN SURPRISE**—"Before I close I'll give publicity to a tasty recipe for cooking a potato (and "fixings") which reaches me from Newfoundland: Bake large potatoes in their skins till three-quarters done, nearly cut off one end; with a fork hollow out the center of the potato and fill in the hollow with a shaving of broiled bacon, peppered and tightly rolled; close the potato by the lid end, bake for 5 minutes." **POMMES A LA BIGNON**—Boiled potatoes in their skins, peeled, when cold; inside hollowed and filled with mutton-mince highly seasoned, end closed with piece of potato, browned in butter in the oven. **POMMES A LA REITZ**—French fried potatoes. **POMMES A LA BORDELAISE**—Cut thin like chips, fried soft, taken up into frying pan and finished with butter, onion, parsley fried together. **POMMES A LA BRABAN-**

## POT

**CONNÉ**—Dish of baked mashed potatoes in which parboiled onions and parsley and cheese are mixed; browned in the oven. **POMMES A LA VILLAGEOISE**—Hash-cream potatoes. **POMMES A LA BRETONNE**—Cold boiled, in blocks fried with onions; brown sauce. **POMMES A LA COLBERT**—Cold boiled, in blocks simmered in brown sauce with parsley. **POMMES A LA NAVARROISE**—Raw, cut in large blocks, parboiled, fried light color in oil. **POMMES A LA ROUENNAISE**—Preparation as for potato croquettes; in very small balls dipped in batter and fried like fritters. **POMMES CROUSTADES A LA REGENTE**—Potato croquettes, one end cut off and part of inside hollowed out, filled with patty mixture of lobster, etc., end replaced, served standing upright. **POMMES A LA HOLLANDAISE**—Cut raw into shape of sections of orange, boiled barely done, drained, shaken up with butter, salt and parsley dust. **LONG BRANCH POTATOES**—Long strings cut with machine, fried. **FRIED PUFF POTATOES**—French fried, cooked slowly while the fat gradually cools, drained, thrown at once into very hot fat and browned. They puff out; to be served as soon as done. **SARATOGA CHIPS**—Sliced raw extremely thin with a machine, washed and steeped in water for the starch to settle, drained, fried curly and crisp in plenty of hot lard; fine salt dredged over. "At the bakery it was learned that the concern has a monopoly of the business in this city, and that there are only three makers of Saratoga chips in the country. Chips are an American institution, and are not known abroad save from some small lots that have been exported. The process of manufacturing is in part a secret. The potatoes are peeled and sliced by machinery. They are washed and then dried between muslin cloths. If they were now fried, the amount of starch that they contain would make them brown, and the secret of the business is to remove all of the starch, so that the chips will be perfectly white. When this is done they are put into the hot grease, and come out curled and crisp and with the delicious flavor that has made them famous the world over." **BROILED POTATOES**—Cold boiled or raw potatoes either can be broiled and buttered while broiling. **FRENCH FRIED POTATOES**—Raw, cut in 12 or more strips lengthwise, thrown into hot lard, fried light brown and dry, fine salt. **STUFFED POTATOES**—Baked in their skins, part of inside removed, seasoned with cheese and butter, put back and end replaced. **POTATOES A LA PARISIENNE**—Potato balls scooped out of raw potatoes with a "potato spoon" in size of cherries, fried in hot lard. **POTATOES A LA CONDE**—Balls twice as large as the preceding, boiled barely done, finished by frying very light color in hot lard; fine salt and parsley dust. **BROWNED POTATOES A L'ANGLAISE**—Balls size of crab apples formed with the largest "potato spoon" to imitate new potatoes, but all precisely alike, parboiled, finished in a pan with roast meat fat in the oven. **POMMES A LA BREBANT**—Large dice cut from cold boilded pota-

## POT

toes, sautéed in frying pan with minced onion; salt and parsley. **LYONNAISE POTATOES**—Sliced cold boiled potatoes in a frying pan with minced onion in butter or fat; salt, pepper and chopped parsley added while frying. **POTATOES A LA MILITAIRE**—Croquette preparation in small balls fried. More of same formed in a tin mould like a conical tent and the center of it filled with minced chicken; the tent turned out in center of dish, egged over, browned, and cannon balls piled around it with decorations of green.

**POTATO SOUPS**—See *Soups*.

**POTATO SALADS**—See *Salads*.

**POTATOES IN SWEET DISHES**—Nothing in the domestic history of the potato is more curious than the slow degrees by which cooks came to treat the tuber as a savory and not as a sweet dish—as an accompaniment to the strongest meats instead of a kind of confectionery. Houghton, writing in 1681, speaks of the potato as a pleasant food which may be eaten boiled or roasted with butter and sugar. That he means our common potato is plain, because in the same paragraph he alludes to another and longer kind, the sweet potato, or "batata." Eleven years before Houghton's "Collections" appeared, however, Mistress Hannah Wolley had dedicated to the "Truly Virtuous Mrs. Grace Buzby, daughter of the late Sir Henry Cary, Knight Banneret, and wife of Mr. Robert Buzby, Gentleman and Woollendrapier in London," her "Queenlike Closet or Rich Cabinet stored with all manner of Rare Receipts in Preserving, Candyng, and Cookery." The worthy Hannah has a solitary reference to the "*Solanum Tuberosum*": it is a recipe for making a potato-pie. You are to have your pie-dish and crust ready and "lay in butter," and then "your potatoes boiled very tender," with whole spice and marrow, dates, and the yolks of hard eggs, blanched almonds, pistachio nuts, "candied peels of citron, orange and lemon." Then the crust of the potato-pie is to be closed, and, when baked, the dish is to be served with wine, butter and sugar. Writing nearly eighty years afterwards, Mrs. Hannah Glasse, in her "Art of Cookery," prescribes among the ingredients of a potato pudding, eggs, sugar, butter, nutmeg, currants, half a pint of sack, and a pint of cream. **POTATO CAKE**—This is very simple; steamed potato mashed up, a little flour and butter worked in, with sugar, currants, sultanas, and chopped peel. Form it into a rather soft dough. Roll it out to the size of a dinner-plate, and about an inch and a half or two inches thick. Place it on a greased baking sheet, mark it across with the back of the knife into eight or sixteen divisions; wash the surface over with egg, bake, slip it on to a plate, dust over with pulverised sugar, and serve hot. **AMERICAN POTATO PIE**—Steamed potatoes mashed, mixed with butter, sugar, eggs, nutmeg and sherry, baked like a custard in a pie plate lined with paste, no top crust, fine sugar over when done. (*See Sweet Potatoes.*)

## POT

**POTATO PASTY**—A meat pie having a bottom and top crust of mashed potatoes instead of flour paste.

**POTATO FLOUR**—Potato flour is extensively manufactured in Germany, and is used by sausage makers, bakers, confectioners, and cooks for powdering purposes. Weaving establishments use it to give their goods a glossy appearance, and to size the threads in the woof. It is also used in the manufacture of starch, potato sugar, and white syrup.

**POTATO STARCH**—The potato starch which settles at the bottom of the tub of water in which large quantities of Saratoga chip potatoes are steeped is saleable to candy makers. It may be washed over again in clear water as starch does not dissolve in water that is cold; when settled again the water can be poured off and the starch then dried and powdered. It is used in shallow trays to receive the imprints of fancy bon-bons and creams, these being the moulds into which the new-made candy is poured.

**POTATO POISON**—"No one should buy their potatoes of grocermen who let them stand in front of their stores in the sun. Potatoes belong to the 'Solanum' family, of which the deadly nightshade is one of its full brothers. All branches of the family contain more or less of that poisonous narcotic called 'solanine.' The bulb, or potato, contains the least of this, unless they are exposed to the sun, which rapidly develops this element." Potatoes which have been so exposed have an acrid, bitter taste and bite the palate like mustard. But they are not past recovery. Let them be buried in the earth two feet deep for several weeks and they come out equal to newly-dug tubers, well-flavored and wholesome.

**POTATO SPIRIT**—We are told by the French authorities, and we have no reason to doubt the veracity of their statements, that nearly one-half of the brandy imported into Her Imperial Majesty's British domains is nothing more or less than potato spirit—one of the very worst and fiery of spirits, heretofore supposed only to be used by absinthemakers of the most unprincipled type. The *modus operandi* of its preparation for the British market is somewhat similar to the treatment employed in the making of sawdust brandy from the sawpit refuse, and the dust of pine and fir trees. The potato undergoes treatment with sulphuric acid and water to develop or change the dextrin into grape sugar. This, after many hours' boiling, is mixed with a certain proportion of lime, which causes a precipitate, and destroys or changes the sulphuric acid taste and qualities. It is then fermented with sound malt leaven for about three days, when it is distilled, giving an abundant yield of pure spirit of the strongest and most virulent type.

**POTIRONS** (Fr.)—Vegetable marrows; same as *giraumons*.

## PRA

**POT HERBS**—The soup bunch sold by market gardeners.

**POTTED MEATS**—They are of two classes. (1) The pasted meats like the potted tongue, ham, etc., sold in cans at the fancy grocery stores. (2) Hot or cold meats cooked by slow baking in a covered jar, same as English jugged meats. (*See Potted Hare, Jugged Meats.*)

**POTTED CHAR**—"While you can obtain potted char in London, do not dream of a journey to Worcester for the sake of lampreys. This charming fish, the *poisson rouge* of St. Evremond, is without question the most exquisite breakfast luxury we possess; it stands far in advance of all potted things, and our minor poets should lay the fact to heart that it was after a meal of char that Wordsworth wrote his "Ode to Immortality"—fit product of the ethereal feast."

**POULE-AU-POT SOCIETY**—Association of Paris hotel and restaurant keepers for social purposes, the name having reference to the national soup.

**POULE-AU-POT**—Chicken pot; the richer pot-au-feu. (*See Pot-au-Feu.*)

**POULET** (Fr.)—Pullet.

**POULETTE, SAUCE**—Cream-colored, made of broth or strained chicken liquor thickened with flour and butter and then with yolks. Parsley and lemon juice to finish. It is Allemande sauce with parsley.

**POULARD** (Fr.)—Female capon.

**POUND CAKE**—See *Madeira, Genoise*. The same sort made of 1 lb. sugar,  $\frac{3}{4}$  lb. butter, 10 eggs, 1 lb. flour. Pound cake is the familiar American term while the other names and variations of quality are little known.

**POUSSIN** (Fr.)—Spring chicken. **PETITS POUSSINS**—Very young chickens.

**PRAIRIE HEN**—Ruffed grouse. For ways of cooking see *grouse*. The prairie hen is abundant in the Western states, gathering in flocks of 50 or more in the neighborhood of corn fields. This bird is very much better when cooked in its simplest manner than if overseasoned with artificial flavors. It is generally served in the restaurants split open and broiled like a chicken, with butter and currant jelly. One bird is generally enough for two portions if full grown. However, only young birds should be broiled, the old ones may be potted or made into pies. The breast of the prairie hen is the principal part of it, and is very solid meat. **PRAIRIE HEN PIE**—Prairie hens are very good in a pie. Choose two plump birds, pluck, draw and wipe them; cut off the legs at the first joint, and remove the heads; season them inside with pepper, salt, butter, and minced parsley mixed together. Line a pie-dish with slices of ham and seasoning of pepper and salt; put the birds into the dish, add more slices of ham, pour over them half a pint of good beef stock; line the edges of the dish with puff paste, and

## PRA

cover over with it; brush over with yolk of egg, and bake in a not too fierce oven. **ROAST PRAIRIE HEN**—"Prairie hens, grey hens, black game, ptarmigan, and capercaillie are in season. The first named are excellent eating, and better plainly roasted than cooked by any other method."

**PRAIRIE OYSTER**—A raw egg broken in a bar glass, vinegar and pepper on it, taken raw.

**PRAIRIE DOG**—"This bold gastronomist, instead of being offended at the idea, thought that he would see what prairie-dog was like. He shot two, had them cooked, and liked them so much that he got through the bulk of the brace at one sitting. His son, he says, had a prejudice against eating dog, but he overcame his prejudice sufficiently to taste the dish, and the result was that he finished it."

**PRAWNS**—A larger kind of shrimp. The canned shrimps so-called are prawns. These grow to an extraordinary size on the coast of the Gulf of Mexico, some specimens reaching a length of 8 or 9 inches without the horns and being large enough to cut in lengths after being divested of their shells. Prawns can be cooked in a variety of ways and are excellent plain to eat cold. Nearly all the ways of preparing lobsters and crayfish for the table are suitable for prawns, as in patties, pies, salads, aspics, curries, soups, stews and gumbo. (*See Crevettes, Chevrettes, Crevettes-Boucs.*)

**PRETZELS**—"After many inquiries, I have at last discovered the address of the bakery in Paris which supplies such *brasseries* as Dreher's, Vetzels, etc., with the thirst-provoking *Bretzel*. It is a firm of Alsatian origin, the founder of which introduced this insidious pastry into Paris. This house has almost exclusively the *Bretzel* trade in its hands, and does a colossal business, for the *Bretzel* is now as popular with French beer drinkers as it is beyond the Rhine. Six vans are continually engaged in delivery. The firm also deals in ox muzzles, a favorite specialty for salads, Munster cheese, and black bread." These *Bretzels* are commonly called Pretzels in this country. They are made of common bread dough well baked as if for crackers. They are dropped first into boiling lye, when, if just proved enough they sink for ½ minute and then rise. They are taken out, salt sprinkled over them, and then baked.

**PRINTANIERE** (*a la*)—With young spring vegetables, asparagus points in particular.

**PROFITEROLLES**—One of the three or four names attached to the hollow puffs popularly known as cream puffs, or cream cakes; the variations in the fillings and flavorings are, however, numerous. The profiterolles are small like walnuts when baked and hollow, and are either served in soup or rolled in syrup and chopped almonds, etc. (*See Queen Fritters.*)

**PRUNES**—French plums, well known in the dried state. They are used stewed for supper fruit

## PUD

and can be made into puddings, roly-pôlys, pies, and mixed in cakes.

**PRUNELLES**—Small prunes of an acid nature produced in California, used as stewed fruit.

**PTARMIGAN**—The white grouse, white only in winter. Otherwise called spruce grouse. It inhabits high, mountainous regions. Its flesh tastes of the spruce leaves upon which it feeds, but not unpleasantly. Cooked as grouse and prairie hens.

**PUDDINGS**—A number of the old standard puddings can be found described under the respective letters; the list to follow here are names likely to be met with in French bills of fare. **WHENCE COMES PUDDING**—"English 'sweets' have an acknowledged place of honor in the science halls of the greatest French chefs. Le pouding is 'the pudding,' nothing more, nothing less; English by its name and English by its nature." **POUDING AUX POMMES**—Apple pudding of alternate layers of bread crumbs and stewed apples. **POUDING AUX MARRONS**—Chestnut pudding. **POUDING AUX FIGUES**—Fig pudding. **POUDING AU RIZ**—Rice pudding. **POUDING AU GINGEMBRE**—Ginger pudding. **POUDING AU CHOCOLAT**—Made of sponge cake crumbled, moistened with raw chocolate custard, steamed. **POUDING AUX CAMEL**—A mould or individual small moulds are coated inside with candy made by melting sugar over the fire without water; the moulds are then filled with strong custard or other suitable mixture and steamed. When turned out the caramel coating comes with it and serves as sauce, as it is nearly dissolved. **POUDING A LA MARMELADE**—A marmalade of any variety. **POUDING AU BISCUIT DE SAVOIE**—A sponge cake pudding with brandy poured into it. **POUDING AU PAIN**—Bread pudding of any of the numerous varieties. **POUDING AU PAIN BIS**—Brown bread pudding. **POUDING AUX ABRICOTS**—An apricot pudding or apricot cream tart. **POUDING A LA VICTORIA**—A variety of plum pudding with dried cherries instead of raisins. **POUDING AU MACARONI**—Macaroni pudding. **POUDING AU VERMICELLE**—Vermicelli pudding. **POUDING A LA CREME DE RIZ**—Ground rice pudding. **POUDING AU TAPIOCA**—Tapioca pudding. **POUDING AU SAGOU**—Sago pudding. **POUDING A L'ANANAS**—Pineapple pudding or cream tart; **POUDING AU CITRON**—Lemon pudding. **POUDING DE CABINET**—Cabinet pudding. **POUDING GENOISE**—A jelly roll made of a sheet of genoise cake rolled up with jam. **TANSY PUDDING**—"Of all the old-fashioned, simple-hearted old puddings formerly common, even in London eating-houses, cowslip and tansy were the most characteristic. Shakespeare no doubt partook of both of them. In both cases the tansy and cowslip have about as much to do with the puddings as the flint stone has with the proverbial broth. The pounded tansies are mixed with eggs and cream, spinach-juice, Naples biscuits, sugar, white wine, and nutmegs. The mixture is thickened over the fire, then put into a dish lined with paste and baked.

## PUF

This may not sound well, nevertheless it was a current pudding—we mean a popular pudding—not so many years ago.” **POUDING DIPLOMATIQUE**—Diplomatic pudding. A cold cream ornamented in a mould. It is made like *jaune-mange*, or velvet cream, or Italian cream; a yolk of egg custard with gelatine in it enough to solidify it when ice cold, and flavored with brandy and vanilla. The mould is coated with clear wine jelly by turning it about on ice and decorated with candied fruits stuck on the cooling jelly. More candied fruits are mixed in the yellow cream which is then poured in to fill up the mould. **POUDING DE CABINET GLACE**—The same yellow cream with gelatine in it as for Diplomatic, but the mould lined with lady fingers like a *charlotte*, on the sides and the bottom covered with *ratafias*. Thick cream mixed with the gelatine custard. All set in ice and turned out and served very cold, with whipped cream. **POUDING SOUFFLE A LA PRINCESSE**—Yellow yolk of egg custard made with cream as for Diplomatic, then mixed with apricot marmalade diluted with orange juice. When nearly cold some whipped whites mixed in, set on ice in a mould. In all these there should be 1 oz. gelatine to each quart. With too much gelatine the compositions are hard and leathery, with too little they will not keep shape. (*For other puddings see Ices.*)

**PUFFS**—Two distinct sets of pastries are understood by this designation: puff-paste tarts, turnovers, *vol-au-vents*, *Banburys*, *Coventries* and the like on the one hand and on the other a variety of cakes made of *peties-choux* paste, represented by cream puffs and *eclairs*. A score or more different cakes are included in this class, mostly baked, but some are fried, as Spanish puffs.

**PUITS** (Fr.)—Wells. Applied to tartlets of puff-paste which are tall and have a cavity in the center. **PETITS PUIITS D'AMOUR**—Little Love's wells; tall puff tartlets filled with jelly.

**PULLED BREAD**—In most good establishments “pulled bread” is served with cheese, it being an acceptable substitute for the usual bread or *biscuits*. Pull a loaf while steaming hot apart—pull, not cut; take a fork and dig out pieces of the hot bread the size of large nuts, leaving them rocky. Place these “snaps” back in the oven, and leave them until nicely brown. Do not, however, let them harden too much, or they will be almost uneatable instead of being nicely crisp. A stale loaf may be treated in the same way, but the “snaps” will not be quite so nice.

**PUMPKIN**—One of the American specialties. **PUMPKIN VINE GREENS**—Real spinach is, of course, out of the question in July, August, and September, but several toothsome substitutes are obtainable. For instance, a glorious dish of summer spinach may be obtained by pinching out the growing points of pumpkin vines two or three inches in length. These, when cooked and served as

## QUA

spinach, are of the loveliest emerald-green color, and most delicious flavor.

**PUMPKIN PIES**—One quart of sifted pumpkin, one quart of rich sweet milk, 12 eggs,  $\frac{1}{2}$  pound of butter, 1 pound of sugar, 2 grated nutmegs, 4 spoonfuls of rose water. Bake the mixture in a puff-paste in pie pans. **PUMPKIN BUTTER**—Marmalade made by stewing down pumpkin with sugar or light molasses, ginger to flavor. **BAKED PUMPKIN**—(1) Slices in a baking pan with salt and roast meat fat baked until tender. (2) Southern way, slices in a baking pan with sugar and butter baked with frequent basting. (3) Sections of pumpkin not peeled, baked without any addition, served like baked potatoes. **MASHED PUMPKIN**—Steamed or baked, mashed like potatoes, and browned in the oven. **DRIED PUMPKIN**—Thin slices hung upon strings and dried form a regular article of merchandise at some country stores; the “pumpkin chips” only need soaking in water to be as good as when fresh for making pumpkin pies. **CANNED PUMPKIN**—Can be bought for hotel use in every town. **PUMPKIN BREAD**—Steamed and mashed pumpkin is used in some sections to mix with corn meal or meal and flour to make a sweetish kind of cake.

**PUNCH**—Said to be named from a word signifying five, because of its five ingredients: sugar, lemons, spirit, water, spice. (*See Drinks, Ices, Spirits.*) **PUNCH AND TURTLE**—“Punch is certainly too strong and tasteful with turtle soup, thick or thin, and it is barbarous and old-fashioned to drink it. It impairs the sensibility of the palate for all wines afterwards. If wine must be drunk at the turtle stage of a dinner, perhaps fine madeira or sherry is least objectionable.”

**PUREE**—Mashed ingredients rubbed through a sieve or a colander.

**PURSLANE**—A garden weed with thick, fleshy stalks and leaves; it grows prostrate and spreads over the ground in rich soil. Is eaten in European countries. **POURPIER EN FRITURE A LA MILANAISE**—Fried purslane. It is punctured and rolled in cinnamon, dipped in batter and fried.

**PYROLIGNEOUS ACID**—Used in sugar boiling to prevent graining and is said to give better keeping qualities to the candy than the other acids used. This acid also preserves meat from spoiling; it is the principle in smoke which cures bacon and sausages.

## Q.

**QUAILS**—Plentiful in almost every American market in the winter season, and the standard dish is broiled quail on toast. This habit or custom in regard to the cooking, although, of course, spontaneous in its origin, is strictly in accord with the verdict of cultivated epicures upon the merits of the quail. **THREE WAYS**—“There are in Paris, in the *cuisines* both of the best restaurants and of private houses, three approved ways of cooking quails,

## QUA

namely, as *cailles a la macedoine*, *cailles au riz*, and roasted. Of these various ways I greatly prefer the latter, as I think, and you will doubtless agree with me, that the quail, and especially the vine-quail, can stand very well on its own merits of flavor alone. The quail is at its best when roasted without the addition of a hundred-and-one kickshaws, however savory and intrinsically meritorious these kickshaws may be." ROAST QUAIL—"The best recipe for roasting quails, and serving them, is one copied from the Cooks' School (*Ecole des Cuisiniers*), which I accordingly reproduce with a strong recommendation. Scorch your quails, clean and restore livers, spit them through the thighs with a little spit, with a small slice of crustless bread between each bird; secure the roast with a skewer passed through each end of the spit; butter the quails with a brush; roast before a sharp fire, basting them carefully for 10 minutes, which is sufficient time to allow for the roasting; salt them and take them off the spit, serving on a hot dish with the bastings for sauce poured over them, and surrounded with slices of lemon." VINE QUAILS—"Egypt is the great source of supply, but for quality and size the quails of Italy bear off the palm, and epicures discover in them what they call the 'Amontillado flavor,' which is attributable to the birds' feeding on the succulent shoots of the vine. These birds should not be dressed in any other fashion than roasted or *en papillotes*. The quail, fair in form, pleasant in color, and delicate in flavor, is utterly spoilt if plunged in any liquid, for so evanescent is the distinctive taste of the bird, that a sharp fire alone will prevent it from evaporating."—CAILLES DE VIGNE—"One of the sights of the streets of Paris to-day are the hand-carts full of live quails (*cailles de vigne*) which are wheeled about by itinerant poulterers. The quails are covered in with a wire netting, through which the customer selects those that promise the most succulence. The birds are usually taken home and killed just before cooking. The price of a plump quail is 20 cents, while a very fine bird will bring ten cents more." STEWED QUAILS—"In such a dish as a *compote* of quails, any flavor the bird might originally have possessed is utterly ruined by the bacon, the parsley, the green onions, the mushrooms, the sauce, and the seasonings with which the stewed *caille* is smothered. 'This dish,' the illustrious *chef* Ude somewhat patronizingly informed his foreign patrons, 'would not do for an English dinner,' an opinion in which we entirely agree. A galantine of quails is not much better. CAILLES BARDEES—"But in roasting, the fewer the trimmings the better the bird. A vine leaf tied over the breast and covered with a slice of fat bacon (the method known as barding) is quite allowable, and though a garnish of water-cresses is not forbidden, only a barbarian would souse the plump mouthfuls in brown gravy. Eaten with toast which has absorbed the trail in the roasting-pan, the quail is a prime dainty, and the man who does not overdo it may credit the tale of Hercules having been re-

## QUA

called to life after such a dietary, and pity the Romans, who ceased only after feasting at Attic banquets to believe that the *coturnix* caused epileptic fits." CAILLES A LA DUCHESSÉ—"To return to my list of specialties of Parisian restaurants, I would advise all diners who visit Laperouse's house on the Quai des Grands Augustins during the autumn months to order, whether it be on the daily *menu* or not, a dish of *cailles au riz*, sometimes called *cailles a la Duchesse*. To prepare them at home proceed as follows: Clean and scorch 12 fat quails, putting their livers back; put them into a pan with some lard and about ½ lb. of salt pork (*petit sale*) cut into little dice. Brown rapidly by tossing them in the pan over a brisk fire; when three-quarters cooked, pour over 2 glasses of good bouillon, add a bouquet of parsley, a leaf of laurel, a clove of saffron, and some cayenne-pepper. Let the liquor reach boiling point three or four times, and then pour into it ¾ lb. of picked rice which has been previously washed with care. Three minutes later cover up the pan, and allow the rice to cook over a slow fire. When this has taken place, take out the bouquet of parsley, and serve the rice on a plate, surrounded by the birds." BONED QUAILS A LA CENDRE—The *chef de cuisine* at the Café de Paris gives the following recipe for a specialty at his excellent restaurant, namely, *cailles a la Cendre*. Bone your quails; fill them with a stuffing composed of poultry breast, bacon, and minced truffles; roll the birds, and butter them slightly. Place them in a row on a baking-tin, on a strip of *abaisse*, or dough rolled out thin. Arrange the *abaisse* so as to keep the birds together whilst baking, to which proceed after wrapping them in a sheet of butter-paper. Cook at moderate heat for 40 minutes. Remove the *abaisse*, and serve. CAILLES A LA MACEDOINE—Quails braised in stock and wine, with their livers and some chopped ham inside them, and bacon, ham, herbs and vegetables in the braise; served on a macedoine of vegetables. CAILLES AUX LAITUES—Quails braised and served with stewed lettuce (like partridge and cabbage.) CAILLES AUX PETITS POIS—Quails with green peas. CAILLES A LA PERIGEOUX—Stuffed with the livers, bacon, and truffles; roasted; served with Perigeux sauce. TURBAN DE CAILLES A LA FINANCIERE—Roast quails cut in halves, dished in a circle with a *financière* garnish in the center. COMPOTE DE CAILLES—Stewed in stock with wine, with slices of sweet-bread, ham, truffles, herbs, and *croutons* to border. CHAUDFROID DE CAILLES—Roast quails, the meat cut in dice in a chaudfroid sauce; served cold in small rolls made for the purpose. QUAILS WITH JAM—An American paper says that blackberry jam is the newest epicurean wrinkle for eating with broiled quail.

QUAHAUG—A large variety of clam; esteemed for its flavor although only a portion is eatable. The favorite way of cooking is egged, breaded and fried same as oysters; the clams appear to be in strings in consequence of the hard portions having been removed as they were opened. Can be bought

## QUA

in cans. Quahaugs are more largely used for fish bait than for eating. They are unknown on the other side of the Atlantic.

QUASS—Quass, the fermented cabbage water of the Russians, is their popular tippie. Next to beer, it has more votaries than any other fermented beverage.

QUASSIA CHIPS—To be bought at the druggists. An infusion in boiling water with syrup makes fly-poison.

QUEEN PUDDING—A meringue pudding, made of a rich bread custard baked one inch in depth in a pan, spread over when barely set with fruit jelly or marmalade, covered with soft meringue, sifted sugar on top and baked light color. Eaten with cream.

QUEEN FRITTERS—The popular name of *beignets soufflés*, made of the same peculiar paste as *petits-chaux* and *profiterolles*, and cream puffs, which is 1 pint water, 7 oz. butter or lard, 9 oz. flour, 10 eggs. The water and butter boiled together, flour dropped in and stirred and cooked to paste, eggs well beaten in, off the fire, one at a time. Small spoonfuls dropped in hot lard enough to float them, expand and become hollow. Eaten with sauce or powdered sugar.

QUEEN'S CAKES—Small drop cakes made of  $\frac{1}{2}$  lb. each butter and sugar, 4 or 5 eggs,  $\frac{3}{4}$  lb flour,  $\frac{1}{2}$  lb. currants. Dropped on paper with the bag and tube, sugared on top, baked.

QUEEN'S TARTS—Grated rind and juice of 2 oranges and 1 lemon, 4 oz. sugar, 5 yolks. Makes a sort of orange custard, the juice being in place of milk. Filled into patty-pans with puff paste bottoms, baked.

QUENELLES—Small balls or egg shapes of pounded white meat. The most elaborately made have the meat pounded in a mortar and forced through a sieve. They are served in consommés and soups and enter in several of the standard garnishes which give names to dishes. They are sometimes made to inclose a highly flavored mince, (*see Consomme Nationale*), and again are made in flattened shapes and the upper surfaces decorated with truffles made to adhere with white of egg. DOMESTIC QUENELLES—"Quenelles are another delicate and attractive form in which cold veal or fowl can be served. Moisten one cup of finely crumbed bread with three tablespoonfuls of cream or milk, drain as dry as possible, add two tablespoonfuls of melted butter, and as much finely chopped meat as you wish; work in well one beaten egg, and season all thoroughly. Flouring your hands, form the paste into round balls, rolling them in flour when shaped. Bring to a boiling heat in a saucepan one large cup of well seasoned gravy, drop in the quenelles, and boil fast five minutes. The gravy can be thickened and poured over them, or they can be rolled in flour or cracker crumbs, and fried in lard or butter, draining off all the grease before serving."

## RAB

QUINCE—A fruit like a pear in shape, useful for preserving, for making jelly and marmalade, but of little importance in comparison with the other large fruits. It is found at its best put up in cans, the long cooking of the canning process being an advantage with so hard a fruit. Can be used in a majority of the ways given for other fruits. (*See Apples, Apricots, Pears.*)

## R.

RABBIT—Rabbit meat evidently occupies an equivocal position in the list of delicacies. It is unquestionably good food. Young rabbit compares favorably with chicken and is made to do duty for chicken sometimes, particularly in the way of canned chicken, potted chicken and in purée soups and pies. Yet one may see that rabbit is not regarded as a luxury in this country in the fact that it is never found in the bill of fare of the dearer class of restaurants and is never in the game course of any high-class dinner, although it may occasionally be found in some more elaborate shape amongst the entrees. It makes all the difference whether such game is scarce and has to be guarded and fostered by gamekeepers in private hunting preserves, or whether it is so plentiful naturally as to be the cheapest of all meat, as it now is in nearly every place, for the western farmers find the rabbit a pest that despoils them of their growing crops, and turn out in winter in concert and destroy them as vermin by the wagon loads. In Australia the plague of rabbits is so serious as to claim the attention of the government, and the canning of rabbit meat and export of rabbits in a frozen state has made this meat as plentiful and common in London as it is in our western towns after a heavy fall of snow, when rabbits are taken by the thousands. Still it supplies a vast amount of good, fresh meat to tens of thousands of poor people who might otherwise seldom taste any. The foreign styles of dressing rabbits here mentioned are to elucidate the contents of French menus; the home methods of cooking rabbits may be at once summed as being the same well-known ways as for chickens. LAPEREAU A LA POULETTE—"Paul, I hear, has made a splendid thing of it. He made his name by means of certain specialties of his, which no *gourmet* who respects himself can, if anywhere near Pourville, pass on without tasting. These specialities are Canard au sang, Matelotte Normande, and Lapereau a la poulette, in all of which Paul, who is his own *chef*, excels. Cut up your rabbit into pieces. Fry these in butter until firm; but not long enough to brown them. Let the butter run off, and let the meat get cold. Then lard the fleshy parts with strips of excellent bacon. Put the pieces back into the saucepan, with a spoonful of flour and a bouquet of herbs, moistening with a glassful of white wine and a little bouillon. When the cooking is half finished, add some onions, some mushrooms cut into pieces, and allow the stewing to finish over a slow fire. When well cooked, strain



## RAB

the sauce, skim off fat, bind with the yolks of two eggs, and pour it over the meat which you have meanwhile arranged on a dish. Just before serving, squeeze the juice of one lemon all over the dish."

**RABBIT WITH SPINACH**—Bone the thighs and legs, replace the bones by pieces of bacon, sew up the openings so as to put the limbs in proper shape again, and put it on the fire in a saucepan with slices of bacon, small onions, carrots, thyme, parsley, a bay leaf, and some stock. Let the whole cook for two hours on a slow fire; then strain off the stock, and serve the rabbit, cut up, on spinach.

**FILLETS OF RABBITS**—Cut the fillets from two rabbits, lard them with fat bacon, and shortly before they are wanted put them into a tin in a hot oven, with plenty of butter, and a little salt strewn over them (the tin should be covered with a sheet of buttered paper); they will only take a few minutes to dress, and should be served with the dish garnished with small mushrooms, slices of lemon and parsley.

Liver sauce is generally sent to table with them.

**RABBIT A LA KIRKHAM**—Boned rabbit. Pieces with the bones taken out. Some rabbit meat run through the sausage machine and made into forcemeat with bread-crumbs and seasonings, part of it stuffed in place of the bones, some spread on the outside of the pieces, egged, breaded, fried; fumet sauce made of the bones, with wine. **JUGGED RABBIT**—Potted rabbit. Wash a large rabbit, and cut into joints; dredge with flour, and fry lightly in butter or dripping, with a few pieces of lean ham. The meat should only be half cooked. Place immediately in a stew jar with pepper, salt, and the chopped rind of half a small lemon. Cover the meat with gravy or stock, and stew gently for two hours. About twenty minutes before serving thicken the gravy with a little cornflour, and simmer in it a few forcemeat balls. **LAPEREAUX A L'ANGLAISE**—Stewed rabbit with Soubise sauce. **PATE CHAUD DE LAPEREAUX**—Rabbit pie, hot. **LAPEREAUX A LA JARDINIÈRE**—Rabbits in a white stew with vari-colored vegetables cut in balls with the potato spoon. **LAPEREAUX A LA TAVERNIER**—White stew with button onions and mushrooms. **LAPEREAUX GRILLES**—Young rabbits flattened, cooked on the broiler, spread with maitre d'hotel butter, served with border of buttered toast in triangular shapes. **LAPEREAUX A LA VILLAGEOISE**—Stuffed and roasted, brown onion sauce. **CIVET OF RABBIT**—See *Civet*. **GALANTINE DE LAPINS**—Boned, stuffed, rolled up in a cloth, boiled, pressed into some shape while cooling, decorated with aspic jelly. (See *Galantines*.)

**RACINES** (Fr.)—Certain vegetables; turnips, carrots and potatoes served as a garnish.

**RADISHES**—In an emergency white turnip radishes may be cooked and served in the place of young turnips, and many prefer them to turnips when nicely cooked. **TO PREPARE FOR TABLE**—Radishes should be kept in ice water; the long reds should be scraped or thinly pared in stripes, a stripe

## RAR

of white showing with a stripe of red. Round radishes may be cut with the point of a penknife so that the outside will curl backwards from the white core like a flower in shape. Radishes are eaten with the fingers like olives and asparagus. **GOLDEN RADISHES**—In the oblations of garden fruits which the Greeks offered to Apollo in his temple of Delpos, they dedicated turnips in lead and beets in silver, whereas radishes were presented in beaten gold. **RADISH TOPS**—Make excellent greens cooked as spinach. **RADISHES IN SALAD**—Much good use of radishes can be made in the decoration of salad dishes, and they are good cut up in various green salads.

**RAGOUT**—The old term for *Garnish*. (See *Garnishes*.) A ragout is a rich compound stew, the components being all in small morsels.

**RAIE** (Fr.)—Ray or skate, sea fish, **RAIE A LA NOISETTE**—Cut in pieces without bone, boiled, served in butter sauce with the pounded liver of the fish and tarragon vinegar.

**RAIFORT** (Fr.)—Horseradish.

**RAISED PIES**—See *Pates, Pies*.

**RAISINS** (Fr.)—Grapes. **GLACE EAU DE RAISINS**—Grape water ice. **TARTE DE RAISINS VERTS**—Green grape pie.

**RAISINS DE CORINTHE** (Fr.)—Zante currants.

**RAISINE DE BOURGOGNE**—Ripe pears boiled in grape juice, the juice previously boiled down to double strength like a natural syrup, the pears, when done stewing, further reduced by baking in jars.

**RAMAKINS** or **RAMEQUINS**—The latter is the French spelling, but is oftenest used. They are cheese puffs or little puddings of cheese baked in paper cases. Made of  $\frac{1}{2}$  pint milk, 2 oz. butter, 1 large tablespoon flour, 2 oz. grated cheese, 4 eggs, pepper, milk and butter boiled together, thickened with the flour; cheese added and eggs well beaten at last; baked in little cases or cups. For lunches or club suppers. **RAMEQUINS A LA RAYMOND**—The same mixture as queen fritters with enough grated cheese mixed in to flavor it well, baked like puffs on pans, dusted with grated cheese before taken from the oven. **RAMEQUINS A LA SEFTON**—Or Sefton's fancy, invented by an epicure of that name. They are puff paste with grated cheese rolled in the layers cut in small shapes and baked. **RAMEQUINS SOUFFLES**—Cheese puffs in paste cups. The mixture made same as frangipane with cheese and salt instead of sugar. When cold whipped whites mixed in, baked in cups or cases. They rise high and are to be served immediately. **RAMEQUINS A LA GENEVOISE**—Pounded butter and hard boiled yolks with grated cheese spread on small shapes of bread and baked.

**RARE**—An English Americanism. At a dinner in Philadelphia a few years ago some one asked

## RAS

an English lord, who was one of the guests, if he would take his duck rare. "Rare, rare?" queried the noble lord; "now there is another of your Americanisms, which makes it so difficult to understand you; and pray, what do you mean by rare?" There was a good American present who promptly piped out from the other end of the table: "We mean by rare, my Lord, what Dryden meant when he wrote: 'Roast me quickly an egg, and see that it be rare.'"

**RASPBERRY**—One of the choicest fruits, most perishable, and of a very transient season. Most valued as raw fruit for breakfast. **RASPBERRIES AND CREAM**—Berries served in glass dishes or saucers, cream aside in small pitcher. **RASPBERRIES WITH ICE CREAM**—A spoonful on top of the cream in the plate. **RASPBERRY ICE CREAM**—Raspberries mixed in ice cream at the finish of freezing, that they may not entirely lose their shape. **RASPBERRY SHERBET**—Berries rubbed through a strainer mixed with syrup and frozen white of eggs added at last. **RASPBERRY SHORTCAKE**—Cakes of short-paste or puff-paste about  $\frac{3}{4}$  inch thick, baked on plates split open, spread with ripe berries and sugar between and on top. Served with cream. **RASPBERRY MERINGUE**—Sheet of cake in a pan, berries an inch deep spread over it, sugar, soft meringue an inch deep on top, lightly baked, cut in squares. **RASPBERRY CHARLOTTE**—Bread crumbs and berries with sugar in alternate layers in a buttered pan, butter on top, baked. Eaten with cream. **RASPBERRY PUDDINGS AND PIES**—See *Apples, Blackberries, Cherries*. **RASPBERRY TRIFLE**—Sponge cake in a shallow glass bowl, saturated with sweetened raspberry juice, then covered with whipped cream and bordered all around with bunches of raspberries. **RASPBERRY SYRUP**—Strained raspberry juice boiled with an equal measure of sugar, kept in bottles, used for all sorts of raspberry preparations; in drinks, in ice cream, sherbet, sauces, etc. **RASPBERRY VINEGAR**—Is a good sauce for all sorts of flour and egg-puddings, and pancakes. Made by putting a quart of raspberries and a quart of vinegar together in a jar to remain 8 days, the liquor then strained off and 1 lb. of sugar to each pint allowed, boiled up, bottled. **TARTE DE FRAMBOISES**—Raspberry open pie. **PAIN DE FRAMBOISES**—A mould of raspberry jam mixed with gelatine, with cream in the center. **CREME DE FRAMBOISES**—Raspberry cream. (See *Bavarois*.) **GELEE DE FRAMBOISES**—Raspberry jelly. **GLACE CREME DE FRAMBOISES**—Raspberry ice cream. **RASPBERRY OMELET**—A sweet omelet having thick stewed raspberries in the center rolled up in it. Sugar on top.

**RASPIINGS**—The bakers rasp off the brown crust of loaves which may be too dark and the raspings are used to give a browned appearance to some baked dishes and to roasted hams.

**RATAFIA**—A cordial strongly flavored with the kernels of stone fruits; made by steeping some hundreds of kernels of peaches, apricots, necta-

## RED

rines and cherries in a gallon of brandy with a pound of loaf sugar, for several months. Used for flavoring liquors, drinks, ice cream, etc.

**RATAFIAS**—Small macaroons often named in cookery directions, made of 3 oz. sweet almonds, 2 oz. bitter almonds, 2 whites, 1 dessert spoonful brandy in the almonds while pounding, 8 oz. sugar. Drops size of 5 cent piece dropped on paper and baked; see *Macaroons*—these are the same more highly flavored. Used as cakes, but also as flavorings in puddings and creams.

**RAVIGOTE SAUCE**—*Ravigote Verte*; Mayonnaise sauce made green with a mixture of chopped parsley, chives, chervil, tarragon and shallot and spinach green or parsley juice.

**RAVIGOTE SAUCE HOT**—White butter sauce containing vinegar and finely chopped parsley, tarragon and chervil.

**RAVIOLIS**—See *Italian Cookery*.

**RAW STEAK**—Sometimes ordered by invalids. "In certain parts of Germany and France, a 'delicacy' is much patronized by a great many people which is eaten absolutely raw. A raw steak (as fresh as it can be got) is minced, mixed with finely chopped shallots and parsley, and seasoned to taste with salt and pepper. A raw egg is broken over this mess, and the dainty dish is placed before one, with oil and vinegar to add as fancy may dictate." **SCRAPED RAW STEAK**—As called for in American hotels the steak is generally required to be scraped with a sharp knife from a broad round steak, it being a pulp of raw meat, the seasoning depends upon the order.

**RAY**—A specie of flat fish of which there are several varieties. (See *Skate*.)

**RICHAUFFE (Fr.)**—A re-cooked dish; cooked meat served up in some fresh form. Equivalent to *kedgeree*.

**RED ANTS**—Sprigs of winter-green or ground ivy will drive away red ants; branches of wormwood will do the same for black ants. The insects may be kept out of sugar barrels by drawing a wide chalk mark round the top near the edge. Spirits of turpentine will keep all insects from storerooms by putting a few drops in the corners and upon the shelves. Cocoa sprinkled about the places infested by red ants will very soon drive them away.

**REDFISH**—Local Louisiana name of the sea bass or channel bass. It is pale red when freshly caught, but not red like the snapper.

**REDHEAD DUCK**—Ranks next to canvas-back in quality; is often substituted for it; cooked in the same ways.

**RED SNAPPER**—One of the very finest American fishes. Its flesh is the whitest and very firm, if there be a defect at all it may be that the flesh is too firm. Its flavor is delicate without being so decided as to repel the people who do not like fish in general. It is the most satisfactory fish to fry for breakfast, the

## RED

whiteness of the meats howing through the breading and affording a fine color which some other fish never acquire in the pan. The snapper is abundant also, being found in the markets of every considerable town of the middle and southern states and beyond. In color is like the gold fish in the globes, but attains a noble size. **HOW AND WHERE IT IS CAUGHT**—This magnificent fish is one of the most common in the Gulf of Mexico. It is gorgeously colored, very graceful in all its movements, and unusually wary and capricious. In weight it ranges from 2 to 35 lbs., averaging 7 lbs. Its home is in the strictly salt waters of the Gulf a short distance from the coast. There it lives on the bottom at a depth of 60 to 240 feet. The ocean floor of Florida declines gently at first, for a distance of from 30 to 50 miles from the shore, to a depth of 300 feet, then very abruptly descends to a depth of 600 feet, beyond which the slope is more gradual to a depth of about 12,000 feet. The first slope is a sandy one; the second is sandy, rocky and muddy, while the third is wholly muddy. The surface of the second with its uneven rocks afford homes and comparative security for all kinds of small marine animals, such as crabs, barnacles, corals, etc., etc. The red snapper is most prominent in these communities. It is one of the largest, most active and handsomest species. Its life is spent about the patches of rocks, swimming about 6 feet from the bottom among tall branching oscols and waving grasses in a lazy graceful manner, forever on the alert to dash upon some reckless smaller fish. Ordinarily it has about fifty species of beautifully delicate fishes to select its food from. Among these are rare fishes that live only about the coral reefs of warm seas. Even the most celebrated little fish of the Romans—the red mullet, that was so highly esteemed by the epicure emperors, furnishes an occasional meal for the red snapper. In consequence of living upon food of this character, the flesh of the red snapper is peculiarly firm and sweet, being disposed in regular layers that make it especially desirable for serving at the table. The red snapper is caught altogether with hook and line. Vessels carrying 6 to 8 men go from home as far as 250 miles, being then about 50 miles from land. The places where the fish live is found by sounding-lines that indicate the depth known to the fisherman, and that have baited hooks attached which are quite sure to get a victim if there are fish near by and they are disposed to bite. The vessels are anchored over the spot or allowed to drift across it, while the fishermen ply their lines as rapidly as possible. Each man handles a single line, which has two large hooks and several pounds of lead attached. When the fish are hungry they bite as fast as the lines are lowered to them, and even rise near to the surface of the sea in their eagerness, biting at the bare hooks or anything that is offered. From this habit they have gained the name of snappers. Very often two large fish are hooked at once, and then the fisherman has a hard pull, for the snapper

## REE

is gamey. While it is so easily captured at times, there are spells when it cannot be lured by any kind of bait or snare. **BOILED RED SNAPPER**—Put in enough hot water to cover well, resting on the drainer bottom, with salt and little vinegar; simmered about  $\frac{3}{4}$  hour, lifted out by means of the false bottom, and onto a dish, served with any of the usual fish sauces; caper sauce is especially suitable, and Hollandaise potatoes. **RED SNAPPER STUFFED AND BAKED**—Cooked with the head on, the fish having the back bone removed, without quite severing the skin, from the back, and the bone separated from the head at the shoulders; stuffed and restored to original form, fastened with twine. Baked with slices of salt pork in the pan; served with tomato sauce made in the same pan. **RED SNAPPER, FLORIDA STYLE**—Split down the back and laid open in a pan, the skin side down, the upper surface dusted over with salt, white pepper, coloring pepper; set in the oven to get hot; taken out in a few minutes, and warm butter poured over; then baked brown with frequent basting; served with lemons and tomato catsup. **RED SNAPPER AU COURTBOUILLON**—For a fish of 5 to 8 lbs. is required 2 teaspoons coloring pepper,  $\frac{1}{2}$  teaspoon black pepper,  $\frac{1}{4}$  teaspoon cayenne, 2 cloves of garlic sliced thin—all these to be placed in water ready in a cup. Next, 1 onion lightly fried in lard,  $\frac{1}{2}$  can tomatoes added, fish in pieces put in, pepper mixture added; cooked 10 minutes,  $\frac{1}{2}$  cup flour to thicken; served with fried bread. **RED SNAPPER A LA BEAUFORT**—Fish boiled whole in kettle with stock, white wine, water, aromatics; when done, upper-side skin removed, fish glazed, decorated with lobster coral; served with matelote sauce of oysters, shrimps, etc.

**REED BIRDS**—The reed birds of the North are the rice birds of the South. They swarm on the rice plantations to an extent that becomes serious through their depredations upon the grain, and at times all available hands have to be kept on the watch with guns and scare crows on that account. In this way the birds acquire the fatness which makes them equal to the ortolans and fig-peckers of Italy. **REED BIRDS A LA BEECHER**—The following, except perhaps the oyster, was Henry Ward Beecher's favorite way: "One of the dishes was 'reed bird,' and the novel way in which these were served will interest some readers. They were prepared by the cook taking a raw potato, cutting it in two and scooping out enough of the inside to make a hole big enough to hold a reed bird, an oyster and a little butter. These were boxed inside the potato, the whole tied up and baked." **REED BIRDS WITH MUSHROOMS**—Among the most acceptable of entrees is a dish of birds with mushrooms. Truss 2 doz. reed birds, or other small birds, as for roasting; put into each a button mushroom, of which have a heaping pint after all the stalks are removed; put the birds and the remaining mushrooms into a stewpan, season them with a very little salt and pepper, and add either  $\frac{1}{4}$  lb. of fresh butter (divided into four and slightly rolled in flour)

## REF

or 1 pt. of rich cream. Cover the stewpan closely, set it over a moderate fire to stew gently till the birds and mushrooms are thoroughly dry and tender. Do not open the lid to stir the stew, but occasionally give the pan a vigorous shake. When the birds are ready to serve, lay them on toast with the mushrooms placed around. **BROILED REED BIRDS**—Trussed with the head left on and tucked under the wing, their own liver and bit of butter put inside, run side by side on a skewer with a very thin slice of parboiled bacon between each, and broiled on the skewers over clear coals. Served on toast-garnish with lemon and parsley. **PHILADELPHIA SPECIALTY**—"The reed bird, like terrapin and canvas-back duck, is an exclusively American luxury. Our Philadelphia contemporary, *Progress*, avers that the cook who cuts off the head of this feathered dainty 'throws away the most delicious bit of a delicious morsel.'" **REED BIRDS IN ENTREES**—In France the small bird is esteemed an epicure's morsel, and is dressed in a variety of fashions, *e. g.*, wrapped in calf's udder and roasted, broiled in cases lined with quenelle forcemeat, or cooked in beef marrow sprinkled with chopped mixed herbs, lemon juice, and grated crusts of bread. For salmis they are cooked in precisely the same way as any ordinary game would be. For a *vol-au-vent* the reed bird would be boned, stuffed with a rich forcemeat, and served in *vol-au-vent* cases, with mushrooms and a well-made white sauce. *A la Parisienne* they would be boned, stuffed with a game forcemeat and small truffles, then braised, and sent to table arranged on a dish in a crown shape, with veal quenelles in the center, and a game sauce. These fanciful ways of dressing are generally employed for entrees. **REED BIRDS COLD**—In some towns and villages of Northern Italy small birds are treated with the same appreciative kindness. They are roasted on a spit before a sharp fire, and then laid in pickle for a day or two, and then served cold. (*See Alouettes, Mauviettes, Ortolans.*)

**REFORM, SAUCE**—Named for the formerly famous Reform Club of London where Soyer officiated and Ude before him. It is poivrade sauce combined with port wine and currant jelly.

**REINE (Fr.)**—Queen. **PATTIES A LA REINE**—Queen patties. **POTAGE A LA REINE**—Queen's soup, or to the queen's taste.

**REINE-CLAUDE (Fr.)** — Green-gage plum. **REINE CLAUDE ICE**—See *Ices and Gateaux*.

**RELISHES**—See *Appetizers*.

**REMOULADE, SAUCE** — Same as ravigote in appearance, made of hard-boiled yolks pounded with mustard, oil and vinegar, and minced garlic and parsley.

**RENAISSANCE (a la)** — Newly-made, reformed, made over again. Applied only to whole fishes or birds, or complete pieces, like a boar's head, which are formed in natural shape again by the cook.

## RHU

**RENNET**—Liquid used to mix with fresh milk to change it to sweet curd, whereof cheese is made. This sweet curd is useful also in some kinds of dessert, as curds with clotted cream, and, drained as if for cheese, it is mixed with eggs, etc., in various sorts of cheese cakes. Rennet is obtained by soaking the inside lining of a calf's stomach (cleansed and prepared) in water. "Get a calf's bag from the butcher's—in some places they keep them already pickled for the purpose. If you can get one pickled, cut it in halves, and put half in about a pint and a half of strong salt and water; let it stand a day or two, then use the rennet as required, taking care to add fresh salt and water in proportion as it is taken out, to keep up the supply. The other half of the calf's bag keep in reserve in the pickle as it comes from the butcher, and as the rennet from the first half becomes too weak, add a portion of the second half to keep up the strength. About a tablespoonful to two quarts of milk is the amount required; let stand in a warm corner for 2 or 3 hours.

**REVENIR or FAIRE REVENIR** — Short expression used in French recipes to indicate the preliminary half-frying of the ingredients, which is practiced in three-fourths of the dishes prepared by French methods. The outside of the meat and vegetables are quickly fried and after that the stewing begins, stock and wine being added to the former contents of the saucepan.

**RHUBARB**—When preparing rhubarb, particularly for pies, see what a metamorphosis takes place by the judicious addition of a little candied lemon-peel, a little fresh lemon-peel, a squeeze of lemon-juice, and a few sultanas. You will be surprised. **RHUBARB PIES**—Rhubarb will take the flavor of other fruits very readily, thereby enabling the cook to vary the tarts, etc., sent to the table; for instance, a little lemon-peel for addition one day, a few blanched and chopped almonds another, a spoonful of strawberry jam for a third day, plain rhubarb the next, and so on. **RHUBARB MERINGUE**—Fill a deep pie-dish with alternate layers of rhubarb, sweetened and seasoned with nutmeg, and slices of stale sponge cake. Bake twenty minutes. Whisk the whites of three eggs thoroughly, add three tablespoonfuls of sifted white sugar; spread this evenly over the top. Return to the oven for fifteen minutes to brown. **RHUBARB FRITTERS**—Peel young rhubarb and cut the stalks into lengths of about two inches, dip each piece into batter and fry in boiling lard until a nice golden brown. Serve fritter very hot, well powdered over with sugar. **RHUBARB AND BATTER PUDDINGS**—Fill a buttered pie dish with rhubarb cut as for a tart. Make a rich batter with two or three eggs, allowing a tablespoonful of flour to each egg, and sufficient milk to form the mixture into a thick cream. Pour it over the rhubarb, bake and serve with fine white sugar and melted butter. **RHUBARB CHARLOTTE**—Dish lined with slices of bread dipped in butter and sugar, filled with cut rhubarb well sugared, covered with

## RIC

bread, baked. RHUBARB COMPOTE—Red rhubarb cut 3 inches long, set on side of range in cold water; when scalded, but not boiled, taken up; the water boiled down to a pint, 1 pound sugar added, boiled to make syrup, poured over the rhubarb. To be served as other compotes. RHUBARB JAM—Rhubarb is very wholesome, and also one of the most useful articles of food, coming in, as it does, when apples go out of season. Made into jam with the aid of a few oranges, it makes a tasty, useful, and very cheap dish. RHUBARB CHAMPAGNE—"When making punch for a party, instead of *champagne*, use a quart bottle of *rhubarb wine*. According to the legend of a friend of mine, himself a writer and expert on wine subjects, 'Lord Haddington, who was the greatest wine connoisseur of his day, could not tell champagne from rhubarb wine;' and the fact of its being 'rhubarb' would ensure its not playing 'old gooseberry' with your guests." RHUBARB WINE—To begin with, choose a good juicy kind of rhubarb, the more delicate and rose-tinted the growth the finer will be the color of the wine. A sherry or brandy cask is the best, but a lager beer cask sweetened is not to be despised. Bruise the stocks with a wooden mallet on a wooden board, or with a fruit crusher. One old dame at a village near Chesterfield who is celebrated for her rhubarb wine, and "makes for the quality," runs the rhubarb through a wringing machine at tight tension, and her wine soon makes you "tight," by the way. Let it stand a day or so, then strain off the juice. The next operation is to sulphur the cask. Take  $\frac{1}{2}$  oz. of rock sulphur, put it into a small iron tube or vessel, and lower it by a wire into the barrel; ignite it, and bung up the cask for 12 hours, but leave the spile peg out, so that a little air may get in to assist the process of combustion. Next fill the barrel with the juice, reserving a gallon or so to fill up the barrel and replace what is lost in the overworkings of the fermentation. When the fermentation has subsided, add two pounds of refined lump sugar to each gallon of juice, leave the bung out for two or three days, and if no further fermentation appears, bung it up. The wine should be kept in a cool cellar, and in three months it will be ready for use or bottling. A man in New Jersey has for years made a specialty of rhubarb wine and makes a delightful and wholesome beverage, for which he gets on an average a dollar a gallon by the barrel, allowing the city purchasers to do the bottling and fancy labeling. GLACE EAU DE RHUBARBE—Rhubarb water ice. TARTE DE RHUBARBE—Rhubarb open pie.

RICE—A southern luxury, almost a necessity, and the cooking of it is carried to perfection. HOW TO BOIL RICE—The object is to have all the grains separate when done. Drop the rice into plenty of boiling water; as the water is going to be drained off, it makes no difference if there is a large quantity. After the rice has boiled up once, move the vessel to the side and let it simmer until the grains are tender when pinched between the fingers. Then pour into

## RIC

a sieve and let the water run away, put back the rice with some cold water, wash it around, drain that off, then set the drained rice back in the saucepan at the side of the fire for the remaining moisture to steam through it and make it hot again. Toss it up with a fork. RICE WITH CURRY—The right way in which to serve rice and curry, as a second or final entree at the table is as follows: From the dish of rice passed round by the waiter a helping of about 5 or 6 tablespoonfuls should be taken; the curry, chosen from a selection of at least three varieties, should then be handed round, and about 1 tablespoonful ought to amply suffice for the above mentioned quantity of rice; chutney may then be optionally added on one side of the plate from a cruet-stand conveniently placed on the table, and one teaspoonful ought to be enough. RICE CAKE—Baked rice may be used as a vegetable or as a dessert. In the latter case it may be varied by the addition of sweet and bitter almonds pounded, candied cherries, ginger or citron, preserved cherries and raisins. RISOTTO A L'ITALIENNE—Plainly boiled rice in a saucepan with a lump of butter, as much tomato sauce as the rice will take up, and plenty of grated cheese; stirred over fire or baked. (*See Italian Cookery.*) RICE PUDDING—One small cup raw rice, same of sugar, 1 qt. milk; bake in a dish 2 or 3 hours without stirring it. SOUTHERN RICE-PUDDING—One cup raw rice, 1 qt. milk, 1 cup sugar, 2 tablespoons butter, 5 eggs, flavoring; rice, milk and sugar boiled together, other ingredients mixed in; baked. IMPERIAL RICE PUDDING—Cold; ornamental; a mould coated with jelly and lined ornamentally with candied fruits, sliced, by sticking them on the jelly; boiled rice, whipped cream, sugar, vanilla, and gelatine made up like Bavarian cream and filled into the mould; filling is pure white. RIZ AUX FRAISES—Paris specialty. Boiled rice in whole grains covered with sugar-syrup flavored with orange peel. When completely cold, serve it on a dish in alternate layers of rice and fresh strawberries (uncooked). Garnish the dish by surrounding the base of the pudding with some of the finest strawberries. RICE CROQUETTES—Boiled rice with butter, sugar and yolks made into pear-shapes or rolls, breaded, fried; served with sauce or jelly. RICE WITH FRUITS—See *Apples, Apricots, Peaches*. RICE CASSOLETTES—See *Cassolettes*. RICE APPLE-DUMPLINGS—See *Apples*. RICE WAFFLES—One cup cold boiled rice, 2 eggs, 2 tablespoons melted lard, 1 pt. milk, 1 teaspoon salt, 1 teaspoon baking-powder, flour to make a thin batter. RICE-BATTER CAKES—Same as above. RICE MUFFINS, OR GEMS—Cold cooked rice mixed with flour and milk, etc.; baked in gem pans. RICE IN BREAD—Rice is used as an adulterant to make bread carry much water. It is said that the addition of 4 lbs. rice, boiled with all the water it will take up, mixed in the dough will make 25 lbs. more bread out of a barrel of flour.

RICE FLOUR—Ground rice makes white and delicate pastries. RICE-FLOUR CHEESECAKES—One-half pound ground rice,  $\frac{1}{2}$  pt. milk; boiled together

## RIC

like paste;  $\frac{3}{4}$  lb. each sugar and butter, 5 eggs, flavor, mixed with the rice-paste; baked in patty-pans lined with paste. **GROUND RICE BUNS**—One-half pound each butter, sugar and rice-flour, 2 eggs,  $1\frac{1}{2}$  lbs. flour, 1 oz. carb. ammonia,  $\frac{1}{2}$  pt. milk; made up like pound-cake, cut off in rounds, dipped in sugar, baked. **GROUND RICE CAKE**—Four eggs,  $\frac{1}{4}$  lb. flour,  $\frac{1}{4}$  lb. pounded loaf-sugar,  $\frac{1}{4}$  lb. butter, teacup of ground rice, teaspoonful baking-powder. Beat the eggs, flour and sugar well for a quarter of an hour, adding the rice-powder and butter last of all. Bake three quarters of an hour in a hot oven.

**RICHELIEU GARNISH**—Quenelles of chicken, cockscombs and slices of fat livers in brown onion sauce. Dishes finished with this are *a la Richelieu*.

**RILLETTES DE TOURS**—Cold cakes of meat of the head-cheese order. At the Paris ham fairs the rilette makers build up fancy pyramids of small rillettes and decorate them. The cakes are made as follows: 4 lbs. of lean meat is added to 6 lbs. of bacon or caul, the whole being chopped fine and seasoned with salt, spices, and bay-leaves. The mixture is then cooked in a vessel, care being taken to stir it until it is finished, to prevent pieces attaching to the bottom of the saucepan. The fat is skimmed off, the meat chopped, put into earthenware dishes, the liquor poured over. Eaten cold.

**RISSOLES**—Rissole and croquette both signify about the same thing, something crisp. The difference usually observed is to make the rissole with a coat of flour paste, the croquette with a coat of egg and bread-crumbs or cracker meal. The distinctions are not always observed, however. A rissole is a portion of minced meat combination rolled up in a thin coat of pie-paste and fried in a kettle of hot lard. **RISSOLES A LA ROI**—Minced olives and truffles and hard-boiled yolks and whites; spoonfuls inclosed in turnovers of pie-paste; egged, breaded, fried. Garnished with lemons and cress.

**RISSOLETTES**—Small or fancy-shaped rissoles.

**RIS (Fr.)**—Sweetbread. **RIS DE VEAU**—Calves' sweetbread. **RIS D'AGNEAU**—Lambs' sweetbread.

**RIZ (Fr.)**—Rice.

**RIZZERED HADDIE**—See *Scottish Cookery*.

**ROACHES**—The most successful means of destroying or banishing roaches from a building seem to be: (1)—Borax thrown around plentifully where they run, which is near where water is to be found, for roaches drink greedily. (*See Borax*). But it is an indispensable condition that borax be freshly powdered and very fine. The roaches do not eat it but it kills them by adhering to their feet and they die in the efforts to get rid of it. (2)—Phosphorus paste (*which see*) is the only effectual means which others have found. (3)—Red lead and flour in equal quantities mixed together. The paste to be spread on pieces of paper and distributed about the places infested. (4)—Cucumber peel thrown around their haunts. They eat it for the sake of the water it

## ROL

contains and it kills. (5)—Boiling water thrown perseveringly into the cracks and crevices where they harbor. Insect powder does not kill, only stupefies the insects for a few hours and they survive and continue business. The borax and phosphorus paste and the hot water seem to have the highest testimony as to their success in exterminating.

**ROBINS**—Cooked with a slice of bacon over the breast, served on toast in the usual way of all small birds.

**ROCKY MOUNTAIN OYSTERS**—Lambs' fries.

**ROCK BUNS**—Rough rocky looking cakes made of  $\frac{3}{4}$  lb. each butter, sugar and currants, 3 eggs, 3 lbs. flour,  $\frac{1}{2}$  pt. milk,  $\frac{1}{2}$  oz. carb. ammonia dissolved in milk. Makes stiff dough, pieces pulled off rough with a fork baked on greased pans. **ROCK CAKE**— $\frac{1}{4}$  lb. each butter, sugar and currants, 3 eggs,  $\frac{3}{4}$  lb. flour, baked in a mould.

**ROCK SUGAR**—This is the candy rock work used to build up ornamental pieces of confectionery and to sell as sponge candy; it can be made of all colors and flavors: Boil a pint of clarified sugar in a copper earthenware pan to the degree of crackled, (*See Sugar Boiling*); use no acid in the boiling of this; remove it from the fire, and well mix into it a tablespoonful of icing, by stirring it in briskly with your skimmer. As soon as the sugar and icing is well mixed, and rises up like froth, put it into a papered sieve, or into an oiled tin or mould, and when quite cold, break it in pieces. If you have not any icing ready made, mix some sifted loaf sugar with the white of an egg, until it is quite thick, put in a tablespoonful, and it will answer the purpose of icing. If you want it colored, mix the coloring in with the icing. "And now we come to the finest piece in the group, described in the catalogue as 'Stronghold Caske, in piped sugar ornamental work, on a rock made of (soufflé) sugar.' Soufflé sugar—or as it was called in our young days, 'Queen's bread,'—always makes a good bed for an ornamental piece of this kind, and in this case greatly enhanced the beauty of the castle above." (*See Hints on Sugar*.)

**ROES OF FISH**—Shad roes bring the highest prices, mullet and carp roes are as good except in the one particular of color, they are not so white when cooked. **SHAD ROES FRIED**—Seasoned with salt and pepper, rolled in flour, then egged and breaded, fried in little fat in frying pan to prevent curling; tomato sauce. **SHAD ROES A LA MAITRE D'HOTEL**—Steeped in oil with onion, seasoned, broiled, served with *maitre d'hotel* butter. **ROES AUX FINES HERBES**—Shad or other roes in a baking pan with chopped mushrooms, onion and parsley, and salt and pepper strewed under and over, broth and wine, simmered together in slow oven, sauce made in the pan. (*See Laitances*.)

**ROGNONS (Fr.)**—Kidneys.

**ROLY-POLY PUDDINGS**—Favorite kind,

## ROM

boiled or steamed; made by rolling out a sheet of paste (either short paste, biscuit dough, or a special flaky sort made by the puff-paste method, but less rich), covering with a layer of chopped apples or any fruit or mixture, rolling up in a cloth and steaming an hour or two. Every sort of fruit can be used, and mixtures of many kinds, from molasses thickened with flour to fine lemon mince meat.

**ROMAN PIE**—Italian lunch dish. Boil a good-sized rabbit; cut all the meat off as thin as possible and pound it. Add 2 oz. of grated cheese, 2 oz. of macaroni stewed till quite tender, and a little onion chopped fine; pepper, salt and allspice; line a mould with good paste and put in above well mixed; bake for an hour, turn out, and serve cold. Truffles and grated ham or tongue improve the pie.

**ROMAN PUNCH**—Punch of rum and lemons with additions; soft-frozen like *granito*. **SUPERIOR ROMAN PUNCH**—Mix and freeze 2 qts. of lemon water ice; a few minutes before serving, work in with the spatula 2 glasses of rum, 2 of brandy, 2 of sherry, ½ bottle of champagne, and 5 whites of meringue; serve in glasses.

**ROOK**—A species of crow; the young are eaten, generally in the form of rook pie.

**ROQUEFORT CHEESE**—Well-known imported cheese of a dry and solid sort and high flavor. It is ranked among the choice comestibles for high-priced tables. Can be bought at the fancy grocery stores at about double the price of American cheese; size about 6 or 8 lbs. This cheese is made of sheep's milk. "Roquefort, in Aveyron, France, has been celebrated for generations on account of its caves and cheeses; these two items are inseparable, for without the caves the cheeses would be nowhere, and *vice versa*. All round the country is rich in delightful pasture lands and hilly grounds, affording splendid fodder for the sheep, which, reared in hundreds of thousands, develop udders of exceptional size, and yield an appreciable quantity of milk. The ewes' milk is converted into fine cream cheeses, and these are disposed in alternate layers with a sprinkling of powder, made from a special kind of brown bread, which has been subjected to the attacks of a particular kind of mould, peculiar to Roquefort. The farmers who make these 'loaves,' as they are now called, dispose of them to the celebrated *maturers* in the town, the Société des Caves Réunies. The cheeses on reaching the caves are brushed, and then pierced through their substance with numerous minute holes, by means of elaborate machinery. They are then set aside in the caves to ripen, and it is an undeniable fact that nowhere else in the world will the peculiar fungus grow and impart such a toothsome flavor to the cheese as in these caves."

**ROSSINI** (*a la*)—The composer Rossini was a noted gourmet and particularly fond of truffles; the few dishes occasionally met with *a la Rossini*, are distinguished by having a plentiful truffle garnish. His favorite dish of macaroni with truffles it was said

## RUF

ought to have been called truffles with a little macaroni; his favorite salad was sliced truffles with dressing.

**ROUGET** (Fr.)—Red mullet. (*See Mullet.*)

**ROUELLE DE BŒUF** (Fr.)—Round of beef.

**ROULADES**—Steaks rolled up with seasonings and strips of fat bacon inside, tied, fried outside, broth added, stewed an hour or two, gravy made in same saucepan. Served with various garnishes.

**ROUND OF BEEF**—"A round of boiled beef presents a tempting appearance when garnished *a la foret de Senart*. Tie up some large branches of parsley into bunches, and fry; place these as close as possible round the joint of beef, so as to give the appearance of a forest.

**ROUX**—Butter-and-flour thickening for gravies and soups. It is the beginning of several sauces. Butter and flour in about equal measure, but not very particular proportions, are stirred in a small saucepan over the fire together. **WHITE ROUX**—The above when it bubbles and has cooked two or three minutes is done, ready to have water added to it to make sauce or thicken soups, *fricassees*, etc. **BROWN ROUX**—The same allowed to brown in the pan or in the oven, used for brown sauces and stews.

**ROWAN JELLY**—Rowan jelly, made from the berries of the mountain-ash, is by many preferred to red-currant jelly, as an accompaniment to roast mutton, game, etc.

**ROYAL CUSTARDS FOR SOUPS**—These have come to be so called from their being the one showy adjunct to "Consomme Royale." They are pieces cut in some regular shape out of a cake of cooked egg that is like an omelet steamed instead of fried; made by well mixing eggs with a little broth or milk, pouring it into a buttered pan and steaming or setting in boiling water. **PRECAUTIONS**—The custard is wanted to be solid and firm, not porous and crumbly, therefore the mixture must not be beaten light and must not be cooked with furious boiling; it should be set gradually at gentle heat. When cooked and cold it is turned out of the pan and cut in diamonds or cubes, or lozenges as wanted. **VARIETIES OF CUSTARDS**—(1) They are made of eggs with a little seasoned broth mixed in. (2) With eggs and cream. (3) With eggs and fish broth. (4) With egg-yolks and broth, etc. (5) With egg-whites and broth, etc.,—making two colors and kinds. (6) With eggs or yolks mixed with pounded chicken meat. (7) With eggs or yolks mixed with chopped mushrooms, onions and parsley. (8) Green with eggs and purée of spinach. (9) Pink with eggs and red lobster or crayfish butter. (10) They are cooked in small ornamental thimble moulds.

**ROYANS**—Selected sardines; a superior sort.

**RUFFS AND REEVES**—There are some small birds called ruffs and reeves, found in the fenny counties of England, and which doubtless, in some

## RUS

variety or other, are inhabitants of the United States. The ruff is the male, the reeve the female; they are so named from the ruffled appearance of the feathers of the neck. The most delicate and highly valued of all small water fowl, they are made so by the treatment to which they are subjected. They are taken alive and fattened for two weeks on boiled wheat, or boiled bread and milk mixed with hemp seed. The secret of thus fattening ruffs and reeves was discovered by the Yorkshire monks in the Middle Ages; but birds so treated are still extravagantly dear, and considered superlative luxuries.

RUSKS—(1) Slices of sweet loaf bread toasted dry in the oven. (2) Slices of cake such as sponge cake with caraway seed, dried and toasted in the oven. These were eaten as sweet crackers now are for lunches and with wine. (3) American and German bakers make sweetened rolls which are sold by the name of rusks, fresh baked. (4) Several grades of buns, yellow and rich, known by several names across the water, are made in this country under the one common name of rusks; eaten warm.

RUSSIAN COOKERY—The Russians are great soup eaters. Amongst their most favorite potages may be mentioned *Vesiga* soup and cucumber soup.

RUSSIAN VESIGA SOUP—The *Vesiga* is a gelatinous substance that envelopes the backbone of the sturgeon. It is sold in a dry state, and bears some resemblance to Russian isinglass. Before using, it should be soaked several hours in water, and then boiled in some light broth until it becomes quite tender. It is then cut in pieces about one inch long, and served in a clear consommé with or without the addition of vegetables cut in fancy shapes. The *Vesiga* soup is considered in Russia as very nutritious and wholesome. RUSSIAN ROSSOLNICK—Cucumber soup prepared with salted preserved cucumbers (a dainty dish in Russia). It is made as follows: Cut four or five salted cucumbers into squares or lozenges of uniform size, and boil them in water until done. Boil, likewise, some parsley root and celery cut in pieces one inch long. Prepare a chicken broth with two young chickens, and when ready to serve, put the cucumbers, the parsley root, the celery and the cut up chicken into the soup-tureen, and pour over the whole the chicken broth, which has been previously thickened with six yolks of eggs mixed with cream. RUSSIAN CAVIARE—A national relish deservedly popular in Europe is caviare, which is simply the roe of the sturgeon. It is served generally with dried toast, and handed after dinner with the cheese. BEAR'S PAWS A LA RUSSE—Another national dish considered as a great delicacy in St. Petersburg is bears' paws. They are first skinned, washed, and put into a marinade for several days. Then they are cooked in a *mirepoix*, and when done put away to get cold. When wanted to serve, the paw is cut into four pieces lengthways; egged, breadcrumbed and broiled. A sharp sauce, such as *poivrade*, *piquante*, or Robert sauce is

## SAC

served with it. RUSSIAN APPETIZERS—There is just at the present time a craze among the Parisians of the *haut ton* for things Russian which extends to the dishes at table. At not a few good houses the sideboards are now garnished with the *Zukuska*, which always forms the preface to a Russian dinner. The *Zukuska* consists as a rule of caviare, herring, anchovies, smoked goose, smoked sausage and cheese. These delicacies are served on little enameled plates. The guests are supposed to go to the sideboard and help themselves at pleasure, drinking a little glass of bitters or vodka, English gin, or even kummel, to stimulate their appetite. When this has been sufficiently provoked, the company take their seats at the table, where good Russophiles serve a soup prepared from the sterlet, a fish caught in the Volga. There is another soup, which is said to be a great favorite with the Czar and his family. This is the savory "shtshi," the quintessence of all national soups, and which according to a Frenchman lately come from St. Petersburg is prepared thuswise: Take a large and juicy piece of mutton, boil it down with juicy pieces of beef, and an unlimited number of onions, garlic, herbs, beets and spices; and serve the same, cut in small cubes. In Poland, a similar *mixtum compositum* is called "borshtsh," on which the Russian looks down with sovereign contempt. Another soup, which is frequently put upon the Imperial table, is called "okroska," a sort of mush or cold decoction of pears, apples, plums and oat grits, with an admixture of small pieces of meat, herring and cucumbers floating therein. The Czar greatly affects chicken cutlets *a la* Poskarki, *i.e.* a chicken chopped very fine and roasted with slices of bread and eggs, served up in the shape of a cutlet; also pork boiled in milk, eaten with a highly spiced gravy. Other favorite dishes of the autocrat are fish prepared in an infinite variety of ways, and a rich and spicy gravy called *a la* Samoyede (the latter being one of the great secrets of the Imperial kitchen), cucumbers in vinegar, and capons. All these dishes are now attempted in Paris. (*See Coulibiac, Russian Salad, Soups.*)

## S.

SABAYON OR SAMBAONE—A custard containing wine, whipped; a foaming pudding sauce.

SABATIER KNIVES—A special and favorite shape of cooks' knives, the name is that of the original Paris manufacturer.

SACCHARINE—The new sweetening substance obtained, like the aniline dyes, from coal-tar, and said to possess 300 times the sweetening power of sugar. It is a white powder, and although in the crude state insoluble in water, is supplied in a soluble form. A grain or so is sufficient to sweeten a cup of tea or coffee, and as saccharine passes through the system unchanged, it would be of special value to diabetic patients and others to whom sugar is absolutely harmful. The new sweetener possesses an-



## SAC

tiseptic properties, and is a powerful anti-ferment, and hence should be useful as a sugar substitute to jam-boilers and fruit-preservers. We are not aware that it has been experimented with in this direction, for truth to say, "saccharine" is as yet only an interesting laboratory product rather than a commercial article.

**SACCHAROMETER**—A graduated glass tube for testing boiling sugar. (*See Sugar.*)

**SAFFRON**—The petals of a flowering plant dried. There are two kinds which answer the same purposes of giving the color of eggs to cake and various culinary preparations. Can be purchased put in tin boxes at the drug stores. It has been very extensively employed both in medicine and cookery in ancient times and even more recently through an exaggerated estimate of its virtues but its use has very nearly died out. The method of using is to make tea of a pinch of the saffron, which is then added to the dough for buns or cake, or the fish stew or dish of rice, in which ways it is still regularly used in Creole and in Italian and Spanish cookery.

**SAGE LEAVES**—Leaves of a common garden plant; easily grown and perennial. Can be bought in a dried and pressed state in packages. Best flavoring for pork, sausages, goose and tame duck.

**SAGE CHEESE**—A cheese of the customary American York State or Western Reserve sort is sometimes to be met with streaked and marbled all through with sage leaves which have been pounded to a pulp and added to the curd of which the cheese is made. The peculiar flavor of this sage cheese is much admired generally, although the distrust with which Americans look upon "mouldy" cheese brings this under the suspicion of those who do not know its nature and makes it unsuitable for hotel tables.

**SAGO**—Made from the pith of a palm tree which grows in the East Indies. Each tree will yield from 500 to 1,000 pounds of sago. It is nearly pure starch. There are imitation sagos in the market made of some cheaper sort of starch; the difference becomes apparent in cooking as the imitations dissolve and the form of the grain disappears; the puddings then become thin and watery. Is cooked in all the same ways as tapioca, in most of the same ways as rice and in soups.

**SAIBLING**—Name often met with in Continental menus. "The best and most delicate fish to be had in Vienna are the different species of trout, one of which I have never seen elsewhere, though it certainly surpasses in flavor the ordinary kind. It goes in this country by the name of *saibling*."

**SALADS, AMERICAN**—The three American salads are raw tomatoes, lettuce, and chicken salad. There are other favorites and nearly all varieties are eaten when offered but the distinction in regard to these is that they are wanted, missed and called for if not furnished, and missed by all. Celery can hardly be classed as a salad as it is always eaten

## SAL

plain with salt, it comes next in the list of universal favorites, however, and then may be instanced the potato salad of thinly sliced potato, with parsley, oil, vinegar, onion juice, pepper and salt. After these the lobster salad, and, a degree less common and more expensive, the shrimp salad, and then for lunch or supper another potato salad of sliced potatoes in a yellow creamy dressing made of cooked yolks, butter, raw yolks, cream and vinegar, parsley, pepper, mustard, salt; the butter and cream being the substitute for oil. The taste for oil is soon acquired but as salad oil is not an article of general household consumption throughout the country it is anything but acceptable to the people who first try the stronger salads at the hotels. Still the practiced diner in general prides himself upon his aptitude at mixing his salad upon his own plate, making the dressing from the contents of the cruet-stands and usually the hard-boiled egg which he finds upon the top of the dish of lettuce; sometimes he must have a raw egg and with oil, mustard, vinegar and seasonings, compounds his own mayonnaise. However, this more elaborate dressing can generally be obtained from the *chef's* department and in most hotels there is at least one salad each day dressed with mayonnaise and decorated before it is served. SAID ABOUT SALADS—"In strolling through the central markets of Paris recently we were struck with the variety of salading displayed on the vegetable stalls. There is an old French book describing the 300 salads of Father Matthew, and it is said, and with truth, that a Frenchman may have a different salad for every day of the year. The proper moment for serving and eating green salads is with roast meat, and more particularly with the game or poultry of the second course. There are people who, without being professed vegetarians, would rather eat a salad without meat than meat without a salad." A NATION DESTITUTE OF SALAD BOWLS—"It is a matter of hard fact that a salad-bowl is a thing unknown to 999 out of 1,000 eating-houses in England. In private houses and in clubs of course it is to be found, because English gentlemen of the class who belong to clubs know that a salad to be enjoyed must be mixed, and that it cannot be properly mixed without a good-sized bowl. But let us go into one of Spiers and Pond's establishments—and in singling them out I pay them a compliment. They are at the head of their profession, they have deserved well of the public, and if they fail in any point we may be sure that the failure belongs not to them individually, but to the English system. I have not been to all their establishments, but in those I have visited this is what I find. They keep an immense bowl on the buffet, crammed with a confusion of salad-herbs soaking in water. You ask for a salad. The waiter brings you a wet lettuce cut in halves upon a flat plate, and he puts down beside it an annulated bottle, full of the abominable compound known as salad-mixture. You politely hint to the waiter, first of all, that you prefer not to touch his

## SAL

prepared mixture. He takes it away, wounded in his feelings, and assumes that you are going to eat the lettuce with salt. You next make a demand for oil and vinegar, and try to explain that a salad to be properly mixed must, according to the saying, be mixed by a madman; it cannot, therefore, be mixed on a flat plate. The waiter then brings a soup-plate; if you are not satisfied with that, he brings a vegetable-dish, then perhaps a slop-basin; and if you are still discontented, he tries you last of all with a soup-tureen. As for a salad-bowl—which one can get at once in the paltriest French restaurant—it is not, as a rule, to be found in the splendidly furnished establishments of Spiers and Pond. This simply means that a salad properly prepared does not belong to the English system of the table, and does not enter into the calculations of those who cater for it in public. I sometimes at English inns manage to get a salad-bowl by asking for a punch-bowl. Mine host is nearly always prepared to make punch, though he does not know what a salad is.”

**THE TRUE LETTUCE SALAD**—“Sir Henry Thompson, in his little work, gives a short and clear description how to make this: The materials must be secured fresh, are not to be too numerous and diverse, must be well cleansed and washed without handling, and all water removed as far as possible. It should be made immediately before the meal, and be kept cool until wanted. Very few servants can be trusted to execute the simple details involved in cross-cutting the lettuce endive or what not but two or three times in a roomy salad-bowl; in placing one salt-spoonful of salt, and half that quantity of pepper in a tablespoon, which is to be filled three times consecutively with the best fresh olive-oil, stirring each briskly until the condiments have been thoroughly mixed, and at the same time distributed over the salad. This is next to be tossed well, but lightly, until every portion glistens, scattering meantime a little finely-chopped fresh tarragon and chervil, with a few atoms of chives over the whole. Lastly, but only immediately before serving, one small table-spoonful of mild French or better still Italian wine-vinegar is to be sprinkled over all, followed by another tossing of the salad.”

**SUMMER SALADS**—(1) Dissolve half a teaspoonful of white or brown sugar in a tablespoonful of plain vinegar; add three drops of tarragon vinegar, and cayenne and salt to taste. Break up a lettuce or endive wiped very dry, and add about half teaspoonful of chopped chives; pour over the lettuce a tablespoonful of oil, and well mix it about with a wooden spoon or fork; then sprinkle the vinegar-mixture over and turn all well about again. Garnish with slices of cucumber cut thin, or raw tomatoes cut in quarters. (2) A fresh lettuce washed and wiped dry, chopped tarragon or mint, a few young onions or chives, and half a cucumber. Put into a salad-bowl two tablespoonfuls of oil, a salt-spoon of salt, half a teaspoonful of pepper, a dessert-spoonful of castor sugar, and a dessert-spoon of vinegar. Then add the chopped mint or

## SAL

tarragon and the onions; lastly, the lettuce broken up into small pieces, and stir all together, turning the lettuce over well. Garnish with slices of cucumber. (3) One raw egg well beaten up, a table-spoonful of oil, a teaspoonful of tarragon vinegar, and a dessert-spoonful of plain vinegar. Mix well together; break up a lettuce, pour the mixture over it, and turn it about thoroughly. (4) Two table-spoonfuls of salad oil; break three eggs, drop them into the oil, well beat them up add a teaspoonful of tarragon vinegar and a dessert-spoonful of cream; mix and pour over the lettuce. This mixture will keep for several weeks if bottled and tightly corked up. (5) Cut up a cucumber into very thin slices. drain off all the water that comes from it by pressing the cut slices between two plates; mix a table-spoonful of oil with a table-spoonful of vinegar, add pepper and salt, and pour over the sliced cucumber. (6) Take three or four fine raw tomatoes, cut them up into quarters or halves; make a dressing of a table-spoonful of oil, another of vinegar, a teaspoonful of tarragon vinegar, and a dessert-spoonful of sugar; pour it over the tomatoes; garnish with water-cress. All salads should be made about half an hour or a quarter of an hour before they are to be eaten. Hard-boiled eggs cut in slices may in all cases be used for garnishing. “The presentation to Lord Tennyson by Messrs. Spiers and Pond, of a ‘pint pot neatly graven,’ from the now demolished Cock Tavern, has evoked a fresh crop of gossip anent that Fleet Street rendezvous. Mr. Sala has, of course, joined in, and this is his amusing mem.: ‘I recollect the plump head-waiter at the Cock-Tennyson’s plump head-waiter; or, at least, his twin brother, or his only son, who was the very image of his father. With Mr. H. Sutherland Edwards I went one day, ever so many years ago, to “chop” at the Cock. ’Twas July, and the weather would have suited a salamander. Mr. Edwards fancied a nice cool salad with his cutlet—he was an adept at salad mixing—and asked the waiter for a cold hard-boiled egg. “A hegg!” ejaculated the obese servitor, “a hegg! If Prince Halbert was to come to the Cock, he couldn’t have a hegg!” The plump Conservatism of the Cock prescribed oil and vinegar as the sole sauce for salad; hard-boiled eggs were scouted and banished as things only fit for foreigners and Radicals.’”

**NEST EGGS**—“This specialty, which we owe to American inventiveness, would certainly be attractive amongst cold dishes for the hot weather. Its preparation is as follows: Take a quantity of fresh spring onions, or, if preferred, water-cresses, or mustard and cress, or, indeed, all three, using the onions sparingly if objected to, and construct out of this greenery, in a large deep circular plate or bowl, the nearest semblance of a bird’s nest which the cook’s ingenuity can arrange. Then place in its midst some hard-boiled eggs, whole, but shelled of course, alternately with some pats or rolls of cream-cheese of the same size and shape as the eggs. Milk-cheese may be used, and is sometimes pre-

## SAL

ferred, whilst it is often easier of manipulation into the proper form than that consisting entirely of cream. In serving this dish, a pat of cream-cheese and an egg, together with a due proportion of salad, should be given to each person, leaving everyone to cut up, dress, and season with oil, vinegar, pepper, and salt, etc., according to taste." **BETTER MATERIAL**—"I am not sorry to find that the finely-shred salad-mixture, in vogue when Louis Napoleon III first gave his feasts at the Louvre, are once more the rage; fine thread-like shaves of lettuce, cucumber, and other salad condiments, whilst tender grape-leaves and tendrils from the winter hot-house forcing for spring-fruits, give a piquancy to the dish." **MIXING SALADS**—There is an Italian proverb on salad-making which tells us there must be plenty of oil and salt, but very little vinegar. The same rule is strictly followed in France, and it is a part of every Frenchwoman's education to know how to add these ingredients in their exact proportions. This is so delicate a matter, that it is not usually entrusted to servants in middle-class families. The undressed salad is brought upon the table, and the mistress of the house adds what she thinks is necessary and mixes the whole. True connoisseurs of the vegetable luxury wipe the separated leaves of the lettuce one by one with religious care. They break the foliage for the salad-bowl, never cutting it, and they debate and commingle the component parts of the dressing with anxiety and scrupulous care. A good salad can be concocted, of course, out of fifty ingredients, from nettle-tops and dandelion leaves through cold potato and beetroot to the lettuce and the endive, which are salad plants par excellence. It is in dressing, however, that genius is most exhibited. **THE SALAD OF THE ANCIENTS**—Our ancestors served salads with roasted meat, roasted poultry, etc. They had a great many which are now no longer in vogue. They ate leeks, cooked in wood-ashes, and seasoned with salt and honey; borage, mint and parsley, with salt and oil; lettuce, fennel, mint, chervil, parsley and elder-flowers mixed together. They also classed among their salads an agglomeration of feet, heads, cocks' combs, and fowls' livers, cooked and seasoned with parsley, mint, vinegar, pepper and cinnamon. Nettles and the twigs of rosemary formed delicious salads for our forefathers; and to these they sometimes added pickled gherkins. **THE SALADE JAPONAISE**—The following is the recipe for the famous Japanese Salad, from Alexander Dumas, "Francillon." *Annette*: You must boil potatoes in a little stock, cut them in slices as if for an ordinary salad, and while they are still warm, season with salt, pepper, very good olive oil, with the flavor of the fruit in it, and vinegar. *Henri*: Tarragon? *Annette*: Orleans is better, but this is of no great importance; the principal thing is half a glass of white wine, Chateau Yquem if possible. Plenty of small herbs cut very finely. Boil at the same time some very large mussels with a stick of

## SAL

celery, drain them well, and add to the potatoes you have already seasoned. Turn all over very lightly *Therese*: Fewer mussels than potatoes? *Annette*: Yes, a third less. One must discover the mussels by degrees; they must neither be foreseen, nor must they assert themselves. When the salad is finished and lightly mixed, cover it with rounds of truffles which have been cooked in champagne. Do all this two hours before dinner, that the salad may be quite cold when served. *Henri*: Can one keep it in ice? *Annette*: No, no, no. It must not be treated with any violence; it is very delicate, and all the aromas must be allowed to blend by slow degrees. "This salad is now being offered at most Parisian restaurants—to such an extent, indeed, that we have had rather too much of it. Your correspondent, whose digestion, like that of the tramp who requested the farmer's wife not to fry his steak, is not that of an ostrich, has had "Salade Japonaise" served him since last writing, no less than fifteen times, and is in consequence a melancholy man. The Grand Hotel makes of this salad a specialty at *dejeuner*, each Thursday morning—an innovation which it describes as an original and very Parisian idea." **IMPROVED JAPONAISE**—Dumas's recipe for the Japonaise salad has been experimented with by the Parisian cooks, and as now prepared differs vastly from the famous exposition in *Francillon*. *Chef* Gabriel Berquier, interviewed the other day, gives the following recipe as the perfection of *Salade Japonaise* and the recipe is well worthy of preservation: Boil potatoes in bouillon, mince them up when cold, add shelled shrimps, truffles and tongue cut into the size of halfpence; mix the whole with superior white wine, allow it to macerate for an hour; add to this mixture green sauce as for salad. On the other hand sprinkle minced truffles over slices of fresh or preserved *foie gras*. Prepare a jelly of meat-juice, white wine, oyster-stock, and gelatine, and spread some of this jelly over each slice of *foie gras*. Mask some mussels and some oysters in well-set green sauce. To serve, take a long dish, hollow in center. Salad in center; on salad slices of *foie gras* prepared as above; surround with mussels and oysters. Sprinkle dish over with slices of truffles and of tongue, and make little decorations with the rest of the meat jelly. Send up to table with some green sauce in the sauce-boat." **SALADE DE POMMES DE TERRE AUX TRUFFES**—"A good recipe for a potato salad, which is in many ways preferable to the famous *Salade Japonaise*. Boil and slice the potatoes. Slice also very thin some truffles boiled in white wine. Fill your salad bowl with alternate layers of potatoes and truffles, beginning with a layer of potatoes and finishing with truffles, garnishing this last layer with a row of small, boiled onions, fillets of anchovy and stuffed or plain olives. Season with salt pepper, oil, and vinegar, and, after allowing the salad to become impregnated with the seasoning, serve. This salad will suit those who cannot stomach the mixture of

## SAL

mussels and truffles prescribed in Dumas's recipe. **LA SALADE DU PRINCE DE GALLES**—To which the Heir Apparent is said to be extremely partial—is stated to be composed of sardines boned and cut in small pieces, lettuce, watercress, and chervil with minced capers; the yolks of two hard-boiled eggs pounded into flour are added, with salt, pepper, cayenne, and mustard, and three tablespoonfuls of lemon juice. The salad is garnished with slices of lemon and pickled capsicums. **PLUM'S PRIDE**—Is a capital salad; named after its compounder, a retired butler. Ingredients for six people: Three large floury potatoes, three tomatoes, cooked, a small cupful of sliced cold vegetables of any sort ready, a large lettuce, or two moderately-sized, a few sprigs of watercress, some slices of beetroot, a very little onion of the fine shallot kind, tarragon vinegar and common vinegar to taste, mustard, salt, and sugar to taste, and a teaspoonful each of any sauces you may have in use; oil or cream. The dressing is made in the usual way, the vinegar being added by slow degrees, in the proportion of one tablespoonful to three of oil. The tarragon is used to flavor. Rub the potatoes, while hot, through a sieve, the tomatoes also; and about two inches of beetroot; add the beat yolk of a raw egg with the tarragon, vinegar, etc., and mix all well. As tastes vary respecting the quantities of oil and vinegar, the mixer must use his own discretion. Mustard can be added if liked, also a chopped chili. **LOBSTER SALAD**—This is the salad *par excellence* at this time of year. It is exceedingly fashionable and may be decorated with white rings of hard-boiled eggs and the coral or eggs of the lobster, whilst the fan or tail of the animal and its various long antennæ (feelers) may all play an ornamental part in the getting up of the dish. The lobster must, of course, be boiled, and the meat of the animal, with a sufficiency of green-stuff, forms the basis of the dish. Very small onions and egg radishes may be used when in season, as also chervil, etc. A sauce of oil, mustard, cream, and a little cayenne may be served, either in the dish or separately. The decoration of a salad of this kind may be carried to any length which the fancy dictates. An outer border may be made of alternate slices of boiled potatoes and beet-root, which will look charming. To keep this border in its position, fill the bottom of the dish with aspic jelly, and allow it to set; throw in the "greenerie" in bulk, and cover all with a very thick sauce of cream, oil, and mustard, seasoned to taste; then plant on the center, so as to stand erect, a few of the hearts of the lettuces which have been used, after which build around a border of hard-boiled eggs cut into fantastic forms. **ANCHOVY SALAD**—"At Kettner's famous restaurant in Soho they sometimes serve among the *hors d'œuvres* anchovy-salad garnished with diminutive pickled onions." **SALADE D'ANCHOIS**—"Kettner, or rather his successor, Sangiorgi, gives the following recipe: Wash in cold water some salted anchovies, steep them in vinegar, drain

## SAL

them on a cloth, and take out their fillets, which shired likewise; place them symmetrically on a small plate or a *hors d'œuvre* dish, garnished with groups of hard-boiled eggs, chopped parsley and onion separately also, with whole small capers. Pour a little oil over the whole, and serve." **THE GARLIC FLAVOR**—A slight rubbing of the salad bowl with a clove of garlic will impart sufficient flavor for a moderately sized salad, or a piece of bread crust may be slightly rubbed with garlic and put into the salad bowl while the salad is being mixed, and then removed. **A SALAD OF BOILED ONIONS**—Is quite a delicacy. The unpleasant essence of the onion disappears in boiling, and only its sugar and other innocent and savory qualities remain. This may be recommended for a change. The onions are not to be cooked soft, but sliced and parboiled. **THE ONION FLAVOR**—A new idea for salads is to add the expressed juice of an onion. The effect is said to be excellent and something analogous to the practice of the French cooks, who wipe a frying-pan with a piece of garlic before they make a savory omelette. **SALADE A LA MULGRAVE**—Although very simple in composition this is a *recherche* salad. For 20 persons, say, take 6 cabbage lettuces, clean and mix them with a kind of *remoulade* containing capers. Put this mixture in the salad bowl; then get ready some sliced tomatoes seasoned with oil, vinegar, pepper and salt, and put them round the bowl. Well dished up, this salad is very pleasing to the eye as well as to the palate. **BEET AND POTATO SALAD**—Cooked beets cut in lozenge shapes, and potatoes likewise; kept separate, but seasoned alike with oil, vinegar, pepper, salt and minced onion; mixed together and garnished with parsley or celery at time of serving. One of the prettiest ways in which to garnish winter salads is to fringe short stalks of celery and put around the edge of the salad bowl. Fringe by means of coarse needles. **BLOATER SALAD**—Broil 2 herrings, remove skin and bone and cut the fish into shreds; put into a salad bowl a head of bleached endive; add the fish and 2 anchovies cut up, 1 dozen minced capers and 2 boiled and sliced potatoes; over all strew a few minced herbs, add a plain salad dressing, toss lightly and serve. **CAZANOVA SALAD**—Shred the white stalks of 2 heads of celery in inch lengths and put them in a salad bowl with the whites of 3 hard-boiled eggs also shredded, season with mayonnaise sauce and chopped eschalots, and strew over the surface the yolks of the 3 eggs finely chopped.

**SALAD DRESSINGS**—Home-made salad dressing, it goes without saying, is infinitely better than that bought ready made. A few not generally known items on the subject may be acceptable. First you can boil your dressing and so keep it, tightly bottled for 14 days; take 3 eggs, 1 tablespoonful each of sugar, oil and salt, 1 small tablespoonful of mustard, 1 cupful of milk and 1, or less, of vinegar; stir the oil, salt, mustard and sugar in a

## SAL

bowl until perfectly smooth, add the eggs well beaten, then the vinegar, and lastly the milk; place the bowl in a basin of boiling water and stir the contents till the consistency of custard. **TOMATO DRESSING**—The following recipe for preparing a delightful dressing for the tomato, when used for salad, will be found useful: Beat 2 eggs well together, add 1 teaspoonful of sugar,  $\frac{1}{4}$  teaspoonful of salt, the same of prepared mustard, 1 tablespoonful of sweet cream and 3 tablespoonfuls of vinegar; place the bowl containing it in a basin of boiling water and stir till it attains the thickness of cream.

**PARMENTIER'S SALAD VINEGAR**—Is made as follows: Shallots, sweet savory, chives and tarragon, of each 3 ounces, 2 tablespoonfuls of dried mint-leaves, and the same of balm; beat these together in a mortar and put them into a stone gallon bottle, fill up with strong white-wine vinegar, cork it securely and let it stand a fortnight exposed to the sun, then filter it through a flannel bag. **MAYONNAISE**—See *Mayonnaise*.

Mayonnaise dressing can be colored green with spinach green, red with pounded coral rubbed through a seive, and crushed strawberry with a few drops of cochineal. **ASPIC MAYONNAISE DRESSING**—Melt a cupful of jelly, then put it in a bowl,

place in a basin of ice water, mix with  $\frac{1}{4}$  cup of vinegar, 1 tablespoonful of sugar, 1 scant of mustard, 1 teaspoonful of salt, and a pinch of cayenne; beat the jelly with a whisk, and when it thickens add the oil and vinegar little by little, lastly a little lemon juice, beating all the time. This dressing ought to be very white. **A RAVIGOTE**—"We can recommend the following recipe for French salad dressing. To 3 tablespoonfuls of best salad-oil add a dessert-spoonful of tarragon vinegar, a salt-spoonful of salt, half a salt-spoonful of pepper; chop finely some tarragon, parsley, chives (or a taste of onions), and mix well; it should be made half an hour before the lettuce is added."

**SALAD A LA JARDINIÈRE**—Fine strips of vegetables of various colors all cooked and cold, with green peas and string beans, dressed with oil and vinegar. **SALADE AUX CONCOMBRES**—Sliced cucumbers with oil and vinegar. **SALADE DE CHOUX ROUGES A LA RUSSE**—Russian red cabbage salad with sauce of sour cream, hard-boiled yolks and seasonings. **SALADE A LA RUSSE**—Cooked salad of carrots, parsnips and beets in shapes, pieces of fowl, anchovies, olives, caviare, oil, vinegar and mustard. **SALADE A L'ESPAGNOLE**—Spanish salad of slices of tomatoes and pickled onions, with mayonnaise in the center. **SALADE A LA TARTARE**—Lettuce, pickled cucumbers, onions, herrings cut in dice, oil and vinegar. **SALADE A LA DEMIDOFF**—Slices of potatoes and truffles, shallots, oil, vinegar. **SALADE A LA FRANÇAISE**—Lettuce or any one kind of salad only, with oil, vinegar, etc. **SALADE A L'ANGLAISE**—Lettuce, celery, beets, endive and cress, with oil and vinegar. **SALADE A L'ALLEMANDE**—Slices of potatoes, Brussels sprouts, cauliflower and celery, with oil and vinegar. **SALADE A L'ITALIENNE**—Several

## SAL

kinds of green salad and cooked vegetables, with meat or fish, anchovies, olives and tartar sauce. **SALADE A LA FLAMANDE**—Smoked herrings or any dried fish, pickled shrimps, apples, beets, and potatoes with oil and vinegar. **SALADE DE CRESSON AUX POMMES DE TERRE**—Water-cress and slices of potatoes, with oil and vinegar. **SALADE DE TOMATES**—Slices of raw tomatoes with chopped shallots, oil and vinegar. **SALADE DE CHICOREE A LA FRANÇAISE**—Endive with oil, vinegar and garlic. **SALADE A LA MADAME**—Lettuce with sauce of oil, vinegar, yolk of egg and seasonings.

**SALAMANDER**—An iron with a handle, like a shovel of extra weight, to be made red-hot for the purpose of browning the tops of dishes which cannot be set in the oven; it is held over near enough to toast them.

**SALEP**—A root known by this name grows in England and is used by the country people as an ingredient in puddings. Also: A traveler in Greece tells about a delightful beverage called salep, a decoction from roots, sold in Greek towns only early in the morning. The vendors carry about their can of salep with a charcoal fire under it, some glasses and a can of water for rinsing them; and the cost, a cent a glass. (Probably a kind of sassafras tea.)

**SALMIS**—A way of dressing game. A roasted game bird or animal cut up and best pieces reserved while a gravy is made by stewing down the bones with wine and seasonings, the gravy then poured over the pieces to be served. (*See Game, Partridge, Grouse.*)

**SALMON—HINTS ON SALMON COOKING**—"Salmon ought to be eaten as soon as possible after it is caught. Nothing can then exceed the beautiful curdiness of its texture, whereas your kept fish gets a flaccidity that I cannot away with. N. B.—Simple boiling is the only way with a salmon just caught; but a gentleman of standing is much the better for being cut into thickish slices (cut across, I mean) and grilled with cayenne." "Salmon also, if it be a large fish, is best boiled in portions. After it has been a minute in the boiling water, lift the drain, and let the water flow off; repeat this several times, and it will cause the curd to set and make the fish eat more crisply. Henry William Herbert recommends a kettle 'screeching with intense heat, and filled with brine strong enough to bear an egg.' He deprecates any sauce, as likely to injure its own delicious flavor, and speaks with the utmost contempt of the barbarism of eating green peas or any other vegetable with salmon. The thinnest part of salmon is the fattest part; and if you have an epicure at table, he will certainly feel slighted if not helped to some of it." (*See Scottish, Kettle of Fish.*) **SALMON CUTLETS FRIED**—Dip slices of salmon into Florence oil, strew over them cayenne pepper and salt, and wrap them in oiled paper; fry them 10 minutes in boiling lard, and then lay the papered cutlets

## SAL

on a gridiron, over a clear fire, for 3 minutes longer.

**SAUMON A LA REGENCE**—A whole small salmon covered with fish forcemeat, to which chopped truffles are added; served with Perigeux sauce.

**SAUMON A L'ECOSSAISE**—Salmon crimped and boiled in salt water, served with butter and parsley.

**SAUMON A LA TARTARE**—Broiled salmon steaks with tartar sauce.

**SAUMON A LA HOLLANDAISE**—Boiled in seasoned stock, served with Hollandaise sauce.

**SAUMON A L'INDIENNE**—Salmon cut in pieces stewed in curry sauce.

**SAUMON A LA BEYROUT**—Salmon steaks broiled in papers, served with a sauce of mushrooms, shallots, parsley, and wine in brown gravy.

**SAUMON A LA CREME D'ANCHOIS**—Salmon steaks stewed, and anchovy sauce made of the liquor with butter, etc.

**DARNE OR TRANCHE DE SAUMON**—A thick cut from the middle of the fish.

**FILETS DE SAUMON A LA MARECHALE**—Filets sauté and served with white ravigote or aurora sauce, garnished with shrimps or oysters.

**MAZARINE DE SAUMON**—A steamed mould of salmon forcemeat, decorated with shrimps, served with cardinal sauce.

**MAYONNAISE DE SAUMON**—Pieces of cold salmon with lettuce or celery and mayonnaise sauce.

**CANNED SALMON**—The Columbia river canned salmon is a remarkably good substitute for fresh fish, when, as often happens, the fish does not arrive in time for the hotel dinner, and still the fish course cannot well be left out. It is made hot by setting the cans in boiling water, and the fish should be served without breaking or moving it more than once, and with any of the usual boiled fish sauces. Canned salmon may be scalloped, baked in a dish of cream sauce, or *au gratin* with bread-crumbs and butter on top, in shells, in patties, in cassolletes, croquettes, rissoles, and in various other ways in combination with other fish and shellfish, as in a matelote.

**SMOKED SALMON OR KIPPERED SALMON**—Has always been held a prime delicacy; it is picked apart without cooking, decorated with green and served that way for breakfast or supper, or else thinly sliced and served the same way. Also, steeped in warm water, sliced and made hot in butter and pepper with a little water, or, after soaking, broiled and buttered.

**FOR PACIFIC COAST SALMON FISHERS**—The following is copied from an old cookery book, dated 1753: "To pickle salmon as at Newcastle: Cut pieces according to the size of the fish; then take 2 qts. of good vinegar, black pepper and Jamaica pepper ( $\frac{1}{2}$  oz. each), cloves and mace ( $\frac{1}{4}$  oz. each), and 1 lb. salt. Bruise the spice pretty large, and put all these to a small quantity of water; as soon as it boils put in the fish and boil it well; take the fish from the pickle and let it stand to cool, and then put it into the barrel it is to be kept in, strewing some of the spice between the pieces. When the pickle is cold, skim off the fat, and pour the liquor on the fish and cover it very close.

**SALMON PERCH**—"A Swedish fish, called 'salmon perch,' has been brought to the London

## SAN

markets this year. It is beautifully white in color, and particularly delicate in flavor."

**SALMON TROUT**—A lake-fish resembling both the salmon and the Mackinaw trout, having salmon-colored flesh; but of comparatively small size. It is a fish of the first quality for the table.

**SALISBURY STEAK**—For people with weak or impaired digestion. It is the notion of an American physician. The surface of a round steak is chopped with a *dull* knife, the object being not to cut, but to pound the meat. As the meat-pulp comes to the top it is scraped off, until at last nothing is left but the tough and fibrous residue. The pulp is then made into cakes and lightly and quickly broiled, so as to leave it almost raw inside.

**SALPICON**—Minced meat of any sort highly seasoned with spiced salt, lemon-peel, savory herbs, truffles, etc.; a mince of which a little is sufficient as it is used to inclose in quenelles, or in *petites bouchees*, or small patties, in rissolettes, and to impart savory flavors to meat and game when placed in incisions made for the purpose. Chopped chicken or game with grated ham and spiced salt, moistened with sauce, is an example.

**SALSIFY**—The oyster-plant. (*See Oyster-Plant.*)

**SALT STICKS**—Finger-like small loaves of bread salted on top before baking, eaten with soup and with beer. Made in some hotels specially for a dinner roll.

**SAMPHIRE**—"A specialty of Pegwell Bay is pickled samphire, the curious seaweed so finely described by Swinburne in 'Atalanta in Calydon,'

'Green girdles and crowns of the sea gods,  
Cool blossoms of water and foam.'

The samphire is collected on a small submerged island in the Bay, and is bottled for sale. It gives a pleasant zest to cold meat, and is said to go down particularly well with hot roast mutton." There is a true and a false samphire; the latter is a salt-flat weed somewhat resembling purslane in its fleshy branches, but growing upright; it is also called glasswort from the large amount of soda which it yields to the glass makers; it makes an agreeable pickle. The true samphire, also eatable and sought after, grows on rocky cliffs, and is the samphire mentioned by Shakspeare—"the samphire-gatherer's dangerous trade"—and in the couplet above.

**SANDWICH**—Two thin slices of bread with a thinner slice of meat or something equivalent between. "Meat, or potted meat, fish, hard-boiled eggs, or grated cheese may be used as the lining to the two surfaces of bread, etc. Be careful that the slices of bread are of the same size and thickness; choose bread of a close, uniform texture. Spread the inner surface of each slice with butter, and, if suitable, add a little mustard and salt. Chop the meat, ham and chicken, or tongue and veal, together; or, if only one kind of meat is used, cut thin slices, and cover the buttered surface with them. Lay the

## SAN

other piece of bread or biscuit on the meat and press the whole tightly together. If fish is used, it must be chopped up small, and a little cream and pepper and salt mixed in before spreading. Cheese is to be grated, and for cheese sandwiches plain thin biscuits are always used. For sweet sandwiches use marmalade." When sandwiches are made for a party at ball or pic-nic, the bread should be cut as thin as it can be in square slices; when the filling is in, these are to be cut across, making triangular shapes; then the sides trimmed off, making them all of one size and perfectly even. Pile them up and cover with a dampened napkin till wanted. **THE CHESTERFIELD SANDWICHES**—Are deservedly popular, containing as they do all the elements of a comfortable meal. The interior consists of chicken and ham, accompanied with salad. **SANDWICHES A LA REGENCE**—Are also very appetizing, being made of lobster and small salad. Other excellent mixtures are anchovy and egg, or anchovy and water-cress, the combination of saltiness and freshness being much approved of by the epicure. Another odd mixture consists of sardine and cucumber, two edibles which "nick" exceedingly well, probably on the principle of the attraction between contrasts. These sandwiches are never larger than two inches square, and are served in a pile in a dainty china dish. **BODEGA SANDWICH**—A tempting sandwich which is served in the Bodega wine-stores of London consists of an anchovy rolled round the outside edge of a slice of hard-boiled egg neatly placed upon a thin slice of brown bread and butter. **WOMAN'S FAVORITE SANDWICH**—Restaurant-keepers unanimously agree that the favorite woman's lunch is a cup of bouillon, with a sandwich so thin that it can be rolled up and tied with ribbon. A recent innovation in sandwiches, the idea of which is stolen by report from one of these lunching places for men, where women are not admitted, is to spread one wafer-cracker with jelly, another with *pate de foie gras*, and lay them together, all of which may be very delicious; but a woman's favorite sandwich is an ethereal vision of bread and meat—like two thin pieces of muslin slightly discolored on one side and laid together—a three-cornered combination of frailty. **TONGUE SANDWICH**—Cut up half a pound of cold boiled beef-tongue; put it in a mortar with the yolks of two hard-boiled eggs, a tablespoonful of made mustard, salt, and a little cayenne; pound to a paste; moisten with very little cream; spread the paste on slices of bread, press them together, cut them in two, and serve. The seasoning may be changed as fancy dictates. **SHRIMP SANDWICHES**—Made as follows they will be found decidedly appetizing: Pound 1 pt. shelled shrimps with  $\frac{1}{2}$  small teaspoonful of cayenne, 1 teaspoonful of anchovy sauce,  $\frac{1}{2}$  teaspoonful of lemon-juice, and salt to taste. Cut some thin white or brown bread and butter, spread the mixture on it, cover it with a second slice, press them together, and cut into delicate sandwiches, which serve nicely garnished on a white damask napkin. **FOWL-SAND-**

## SAR

**WICH**—Cut the meat from the breast of a cold boiled fowl into small, thin slices; mince a few stalks of celery; place one or two slices of the fowl on a slice of plain bread, strew over it a quantity of the celery, and pour over the celery a little mayonnaise. **LIEBIG SANDWICH**—Toast two slices of bread, and while hot spread over them a thin layer of extract of beef; add a very little celery-salt; press them together, cut them in two, and serve. **BRIE SANDWICH**—The cheese known as *fromage de brie* is excellent as a sandwich. Take the necessary amount of butter required to butter the slices of bread; chop up a few sprigs of parsley and chives together, work them into the butter and spread over the bread; cut the cheese into thin strips, put it between the slices of bread, and serve. **CAVIARE SANDWICH**—Take a teaspoonful of caviare, put it in a soup-plate, add to it a saltspoonful of chopped onion, a walnut of butter, and the juice of half a lemon; work well together, spread on thin slices of bread, press them together, cut the sandwich in two, and serve. For another caviare-sandwich combination see *Caviare*. **A SQUARE YARD OF SANDWICHES**—"At a restaurant in Gladbach a visitor ordered a roll sandwich. When it came, he thought it looked rather small for the price—20 pfennigs—and sarcastically inquired of the landlord how much he charged for a square yard. 'Five marks,' was the prompt reply. 'Very good, then bring me a square yard of sandwiches.' He insisted on his demand, and mine host had to comply whether he liked it or not. But on reckoning up the damage he found that it took 120 rolls to complete the square yard, which, at 20 pfennigs each, would come to 24 marks instead of 5. Our traveler had a 'square meal' for once, and distributed the overplus among the other guests, who were greatly amused at the joke."

**SANDWICH ISLAND Dainties**—"The following was the bill of fare at a dinner which was given recently by King Kalakaua to a party of American visitors: 'Raw shrimps, kākui nuts, taro, poi, cold chicken, crackers, raw fish, seaweed, raw crabs, raw pig's liver, fruits, coffee, roast dog, ice cream, champagne, lager beer, ginger ale.' The roast dog, we are told, tasted like duck. In Hawaii dogs are kept in pens and fed like pigs."

**SANGAREE**—A drink composed of wine and water with sugar, lemon, lime juice, or other flavors optional. It is named according to the kind of wine used.

**SARCELLE** (Fr.)—Teal duck.

**SARDINE**—"When it reaches its full growth, the true sardine is a little smaller than the herring; at this stage it is fat, oily, and of a mediocre taste. It weighs between a quarter and a third of a pound. This fish, which on the coast of Cornwall is known as the 'pilchard,' and in Brittany as the 'winter sardine,' appears toward the close of the cold season, and vanishes by June. It is then more than two years old. This sardine is salted, but never preserved in

## SAR

oil. It is the so-called summer sardine which is fried in boiling oil, packed in tin-boxes, and shipped all over the world. This is the same fish as the pilchard or winter sardine, only it is a year younger. It arrives off the Breton coast in vast shoals during June, and thenceforward until November it is taken in nets, the bait used being the salted roe of the codfish or a minute species of shrimp procured in the neighborhood. Whither it goes and where it passes the cold season is unknown, but it is believed to be a deep-water fish, which only in the months mentioned comes to the surface. This is certain, however, that it is met with only near that section of the Atlantic coast of Europe which extends from Cornwall to Portugal." HOME PRODUCTS SHOULD BE CHEAP—"Nearly all the fish eaten in America as sardines come from Maine. They are small herring. Sometimes only a bushel or two are taken at a time, and at others so many as to endanger the net. The degree of dexterity with which they are cleaned is astonishing, especially as it is done by very young children. After this they are placed on large gridirons and suspended over a hot fire to broil. The boxes are prepared with attractive French labels indicating olive-oil, but this is false, as the oil is cottonseed. The packing is another operation at which little people are expert. A fish is seized in each hand and laid lengthwise in the box, first a head at the outer end and then a tail. After the boxes are full, a small quantity of oil is poured in, and then they are passed to men who solder them tightly. They are next thrown into an immense caldron, where they are boiled two hours, thus completing the cooking process and dissolving the bones of the fish. The actual cost per box, including all expenses, is said to be five cents." THE SARDINE AT HOME—"It is safe to say that the sardines of Messina are not to be surpassed, though they may possibly be equalled. Like Greenwich whitebait they are rather a specialty of the place. The waiter breathes a shrill whisper through the speaking-tube which communicates from the ground floor to the kitchen. A satisfactory response comes very promptly in the shape of a faint sound of frizzling. As the whitebait are merely immersed for some seconds in a wirework cage in some boiling oil, so the sardines are sent up with startling celerity, considering the Italian habit of procrastination. The tiny fish, delicately browned, are served on a soft bed of frizzled parsley. By way of condiment, there are simply a couple of sliced lemons, and the result is so tempting, so fragrantly appetizing, that you scarcely take time to disengage the fish from the bones." SARDINES EN CAISSES—The fishermen all along the coast from Gaeta to Naples have various ways of cooking fish which are unknown in the great hotels. Many of them are interesting, and might be attractive but for the predominating flavor of garlic. Fresh sardines, crisply fried in oil, are quite admirable eating, but the fishermen have discovered a more excellent way of dealing with them. They

## SAU

place them in a shallow tin, imbed them in bread-crumbs, add a few savory herbs, pour a little good olive oil, squeeze a lemon or two over them, and then bake them over a sharp fire. The result is unexpected, but not disagreeable. DEVILLED SARDINES — (1)—Try devilled sardines for breakfasts, teas, and "snacks." They are easily done. Broiled lightly, a dash of lemon-juice, a pinch of cayenne, and there you are, don't you know! (2)—Take 8 or 10 sardines, drain a little from the oil, cover with mustard and cayenne. Broil lightly, or fry in a little butter or oil. Serve on fingers of buttered toast. SARDINES A LA HORLY—Sardines dipped in batter and fried are nice, though not very substantial, and some persons like pilchards cooked in the same way, though they are too strong flavored to suit all palates; a plentiful accompaniment of lemon is desirable. CANAPES AUX SARDINES—A favorite Parisian dish is made of sardines carefully skinned and boned, laid on slices of buttered toast, and then put into the oven, with buttered paper over them, to get hot. Before serving lemon-juice is sprinkled over. SARDINES WITH POTATOES—Slice parboiled potatoes half an inch thick. Melt a piece of butter in a stewpan, and put in a layer of half the potatoes. A couple of chopped onions and some parsley must be stewed with a piece of butter in a small stewpan. Chop sardines and stir them into the latter. Stew for a few minutes, then spread them over the potatoes in the stewpan. Cover with the other half of the potatoes, and stew them ten minutes; or the whole may be done in the oven, with the dish covered. SARDINES AU PARMESAN—Sardines on buttered strips of toast spread with grated cheese. SARDINES EN PAPILOTES—Fresh sardines boned, stuffed, cooked and served in papers. (*See Appetizers, Canapes, Anchovies.*)

SASSAFRAS—A small tree abundant in the United States, the bark of the roots of which emits a fragrant odor and possesses mild medicinal qualities; used for making sassafras tea, a blood purifier and in sassafras beer and combinations of roots and herbs in beverages and medicines. The bark can be purchased in a dried state at drug stores.

SAUCES—Most of the established standard sauces recognized by modern cooks will be found described more particularly under their respective proper letters. SAID ABOUT SAUCES—"For grilled dishes the following appetiser may be recommended: One teaspoonful of cream, one of vinegar, one of ketchup, a teaspoonful of mustard, one of Harvey's or Reading sauce, a little cayenne and salt; warm in a saucepan, and pour over the grill." THE PROPER SAUCE FOR SALMON—"Never take lobster-sauce to salmon; it is mere painting of the lily, or, I should rather say, of the rose. The only true sauce for salmon is vinegar, mustard, cayenne pepper and parsley." A FISH SAUCE—"A sauce often served in France with many kinds of white fish is made by putting chopped capers, a few drops of anchovy essence and lemon-juice, with a little parsley or tar-



## SAU

ragon, into ordinary melted butter; the combination of flavors is acceptable to most palates." A PARIS SPECIALTY—"Another recipe of *la haute cuisine Francaise*, which is certainly worth noting, is the one for grilled bream with shallot sauce (*Breme grillée, sauce eschalotte*): Clean a fresh bream, scale and cut off dorsal and side fins, also end of tail; trim and oil. Grill your fish over a moderate fire, pouring oil over it from time to time. Serve on a hot plate, with the following sauce over it: Melt three and a half ounces of butter in a saucepan, add two spoonfuls of minced shallot; let cook for three minutes; add the yolks of two hard-boiled eggs, minced fine, two spoonfuls of Harvey's sauce, the juice of one lemon, and some minced parsley." HARVEY'S SAUCE—"A fair imitation of Harvey's sauce may be produced by working the following recipe. Mince a clove of garlic very finely, add 6 chopped anchovies,  $\frac{1}{4}$  oz. cayenne, 3 tablespoonfuls of Indian soy, 3 tablespoonfuls of mushroom or walnut ketchup. Put these ingredients into a quart of the best vinegar, and let them soak for about a month, shaking frequently. Strain through muslin, and bottle for use." STOCK FOR WHITE SAUCE—"A useful stock for white sauce, soups, etc., can be made by using the liquor in which fowls have been boiled. The bones of the fowls themselves, the necks, feet, etc., should all be saved, and with these and a slice or two of lean ham, vegetables, herbs, etc., no other meat will be required, unless the stock is wanted very strong. In this latter case, knuckle of veal is the best thing." "A pinch of sugar is an improvement to all white sauces." ABOUT CAPER SAUCE—"Although caper sauce is the orthodox accompaniment to boiled mutton, it is equally good with roast. Those who doubt should try the experiment." OYSTER SAUCE—"Take 1 pint good white sauce. Open and beard 1 dozen oysters; strain the liquor; put them into the sauce, which should be in a *bain-marie* pan. Warm thoroughly, and let it come just to boiling point; then pour into a hot tureen and serve. The beauty of oyster sauce is that the fish should be like a well-poached egg; just to have the albumen set; no more." HOW TO MAKE OYSTER SAUCE—"What a popular dainty is a tureen of oyster sauce, and how often is it spoiled by the common practice of letting the oysters boil in it! The proper way is to strain the liquor, and boil that with the flour and butter, adding a dash of cayenne, lemon-juice, nutmeg, and anchovy essence, and the oyster the last thing, long enough for them to become hot through, removing the sauce from the fire, so that it shall not boil after they are put in." SAUCE FOR ROASTS—"The following will be found a good sauce for roasts: Simmer a wine-glass of red wine, an anchovy, a little stock, a chopped shallot, and the juice of a lemon in a saucepan. Pass through a tammy, and mix with the gravy of your roasts." LIVER SAUCE FOR SMALL GAME—"Scald the livers, and mince them very fine. Melt a little butter in a saucepan, add a little flour to it,

## SAU

and some minced shallot. Fry for a few minutes, add gravy stock in sufficient quantity to make a sauce, a pinch of powdered herbs, pepper, salt, and spice to taste, then the minced liver and a glass of port wine; boil the sauce up and simmer. Add the juice of half a lemon before serving."

SAUCE—ADMIRAL—Fish. (*See Admiral*.) A LA MINUTE—Quick sauce; flour, water and wine in the pan the meat is fried in. ALBERT—Cream-colored, sprinkled with parsley; contains shallots, horseradish, vinegar, broth, veloute; strained; finished with yolks and cream. ALLEMANDE—Cream-colored; slightly acid. (*See Allemande*.) ALMOND—Sweet; custard with pounded almonds. ANCHOVY BUTTER SAUCE—Brown; espagnole with anchovy butter and lemon juice. ANCHOVY, ANCHOIS—Cream-colored. (*See Anchovy*.) APPLE—Stewed apple strained; little sugar. APRICOT—Sweet; marmalade diluted with wine and sugar. APICIUS' SAUCE—Thick sauce for a boiled chicken. "Pound the following ingredients in a mortar: Aniseed, dried mint, and lazarus root (similar to assafœtida); cover them with vinegar; add dates, pour in liquamen, oil, and a small quantity of mustard seeds; reduce all to a proper thickness with port wine warmed; pour this over the chicken, which should previously have been boiled in aniseed water." \*ARTICHOKE—Purée of Jerusalem artichokes with other vegetables and seasonings. AURORA—Reddish or orange color. (*See Aurora*.) AVIGNON—Cream onion sauce, béchamel, garlic, cheese, oil, yolks. BACON SAUCE—Cold; fried bacon in dice mixed in sauce like Hollandaise. BAHAMA—Fish; chillies and onions in the fish gravy. BEARNAISE—Yellow, buttery, with chopped green. (*See Bearnaise*.) BECHAMEL—White; cream sauce. (*See Bechamel*.) BEURRE—Butter sauce. BEURRE NOIR—Fried butter, brown, with vinegar added. BIGARADE—Brown orange sauce; juice and shredded rinds in espagnole and essence of game. BLONDE—Butter sauce made with stock instead of water. BLONDE FISH SAUCE—Cream-colored with fine herbs mince in it, lemon juice and white wine. BOAR'S-HEAD SAUCE—For cold meats; currant jelly, port wine, mustard, orange rind and juice, shallot, pepper, mixed. BOHEMIAN—White; bread panada diluted with broth, horseradish and butter. BORDELAISE—Brown; espagnole, claret, shallots, garlic, lemon juice, parsley, cayenne, beef marrow. (*See Bordelaise*.) BORDELAISE, WHITE—Butter sauce with shallots, white wine, parsley. BOSTON—Same as Bohemian. BOURGEOISE—Brown gravy with mustard and tarragon vinegar. BOURGUIGNOTTE—Brown; Burgundy wine, espagnole, onions, mushrooms, and truffles. BRAWN SAUCE—Cold; mayonnaise with extra vinegar and sugar. BREAD SAUCE—White; bread panada in milk, onion, butter, flavoring of white wine. BRESSOISE—Of Bresse, noted for fat chickens; brown; chicken livers and shallots fried, brown gravy, bread-crumbs, orange juice; passed through a seive. BRETONNE—Brown; thin onion purée with chopped parsley. BRETONNE,

## SAU

**COLD**—For cold meats; vinegar, sugar, mustard and horseradish. **CALIFORNIA**—Brown; same as Bourguignotte with California wine. **CAPER**—Butter sauce with capers mixed in, and caper vinegar. **CAPER FOR FISH**—The same with anchovy essence or mushroom catsup and high seasonings. **CARROT SAUCE**—On same line as purée of celery, etc.; purée of carrots in butter sauce. **CAULIFLOWER SAUCE**—For boiled fowls; chopped cooked cauliflower in butter sauce. **CARAMEL SAUCE**—Sweet; the brown coating of candy of burnt sugar inside of a pudding mould, which dissolves into sauce while the pudding is steaming. **CARDINAL**—See *Cardinal Sauce*. **CAZANOVA**—See *Cazanova Sauce*. **CELERY SAUCE**—Cream-colored or brown; pieces of white celery stewed and added to either Allemande or espagnole. **CELERY, PUREE OF**—Either white or brown; celery passed through a sieve added to sauce. **CHAMPIGNONS SAUCE**—Mushroom sauce. **CHASSEUR**—Hunter's sauce; brown sauce with tomato, onions, mushrooms, parsley, lemon juice. **CHATEAUBRIAND**—Brown; meat gravy or beef extract, espagnole, wine, lemon juice. **CHERRY**—Sweet; cherries stewed with port wine and sugar, passed through sieve, mixed with butter sauce. **CHESTNUT**—Purée of chestnuts mixed with either white or brown sauce. **CHEVREUIL**—Poivrade sauce with wine, Harvey, currant jelly. **CHILLI**—Pink, variegated; tomato with chopped red pepper, shallots, sliced green limes mixed in white sauce with catawba wine; butter and parsley. **CHOCOLATE**—Sweet; chocolate in boiling milk, sugar, vanilla. **CLAM**—Like oyster sauce; butter sauce with clam liquor, yolks to thicken, and cooked clams added. **CLARET**—Sweet; eggs, sugar, claret, cinnamon, lemon rind; whipped over the fire till thick and frothy. **COCKLE SAUCE**—Same as scallops. **COLBERT**—Brown butter sauce; espagnole, beef extract or glaze, pepper, butter, lemon, parsley. **COURTBOUILLON**—Fish; white butter sauce made with the boiled fish liquor, boiled onion rings, and parsley. **CRAB SAUCE**—Similar to lobster; the crab meat in shreds in butter sauce. **CRANBERRY**—Stewed cranberries with plenty of sugar. **CRAYFISH**—Butter sauce pink, with crayfish butter and crayfish tails. **CREAM**—Butter, flour, cream or milk, salt, white pepper. (See *Roux*.) **CREOLE**—Brown tomato sauce with shallots, wine, chopped sweet pepper. **CRESS SAUCE**—Boiled cress (chopped) in butter sauce. **CREVETTES**—Cardinal sauce with anchovy and pickled shrimps. **CUCUMBER**—Sliced cucumbers fried in butter added to either white or brown sauce. **CURACOA SAUCE**—Sweet; syrup thickened with starch, butter and curaçoa added. **CURRANT JELLY SAUCE**—Jelly, espagnole, and port wine; boiled. **CURRANT SAUCE**—The preceding with whole red currants added. **CURRY**—Yellow; onion, ham, and parsley fried; flour, curry powder, broth, strained, thickened with yolks. **CUSTARD SAUCE**—Sweet; boiling cream or milk containing 4 oz. sugar to a pint; poured upon 3 beaten eggs; brandy, vanilla, any flavor. **CZARINA**—Brown sauce

## SAU

with sultana raisins, gherkins, etc. **DEMI-GLACE**—Brown sauce obtained from the roast-meat pan by adding broth and espagnole. **DEVIL SAUCE**—See *Deviled*. **SAUCE DIABLE**—Devil sauce; grill sauce. **DIPLOMATE**—Fish; pink; cream sauce with lobster or crayfish butter and anchovy essence.—**DIPLOMATE**—Sweet; "dip sauce," thick syrup with flavorings. **DUCHESSE**—Cream sauce with cooked lean ham in small squares, and butter. **D'UXELLES**. (See *Duxelles*.) **EGG**—Butter sauce with chopped hard eggs. **ENGLISH PUDDING**—Custard with sherry whipped over a slow fire till thick. **ESPAGNOLE**—Brown stock sauce made of mixed meats, vegetables and aromatics fried brown in butter, broth added, tomatoes, wine, brown roux, boiled slowly and long; strained. **ESSENCE OF CELERY**—Green celery stalks stewed in broth and the broth added to white sauce. **ESSENCE OF GAME**—Whole birds or rabbits, etc., or the bones only browned, then stewed and the liquor seasoned and thickened. (See *Fumet*.) **ESTRAGON**—Like parsley sauce, tarragon instead of parsley, and little tarragon vinegar. **FERMIERE**—White, containing onion, capers, ham cut fine, wine, broth, butter, flour, parsley. **FINE HERBS SAUCE**—Cream-colored with yolks, shallots, parsley, white wine in butter sauce. **FINES HERBES (Fr.)**—Brown sauce with chopped mushrooms, shallots and parsley. **FLEMISH**—See *Flemish Sauce*. **FENOUIL**—Fish. Like parsley sauce with chopped fennel instead of parsley. **FINANCIERE**—See *Financiere Sauce*. **FLEURETTE**—Thickened rich milk. **FRUIT SAUCE**—For frozen puddings. Marmalade diluted with maraschino and whipped cream. **FOUETEE**—Sweet. Whip sauce of yolks, sugar and wine. **FUMET DE GIBIER**—See *Fumet*. **GAME SAUCE**—Gravy from the roast pan, carcasses of game birds, broth, aromatics, stewed together; espagnole, port wine. **GENEVOISE**—See *Genevoise Sauce*. **GERMAN**—Cold. Currant jelly, orange, horseradish, sugar, mustard, vinegar, oil; mixed. **GHERKIN**—Pickle sauce, brown. Poivrade sauce with sliced pickled Gherkins. **GIBLET**—Stewed liver and gizzards divested of the hard lining, cut up in gravy. **GREEN GOOSEBERRY SAUCE**—For boiled mackerel. Berries stewed, passed through a sieve, mixed with white sauce. **GROSEILLES VERTES**—French gooseberry sauce. Green berries with butter and bread-crumbs. **HACHEE SAUCE**—Brown, mixed. Containing shallots, mushrooms, gherkins, parsley, capers, vinegar, wine. **HAM SAUCE**—Brown sauce with ham and small dice and shallots fried together, and lemon juice. **HANOVER**—Liver sauce for fowls. Poultry livers boiled, pounded, with cream, lemon juice, seasonings; made hot. **HARROGATE**—Gravy in the roasting pan with shallot, lemon rind and juice, catsup, claret, cayenne. **HARD**—Sweet. Powdered sugar and two-thirds as much butter worked together till white and creamy. **HAVRAISE**—Strong broth of boiled fish made into white sauce with yolks and cream. **HERB**—For boiled calf's head. Chopped parsley, chervil and

## SAU

chives with vinegar enough to cover. **HESSEISE**—Cold. Horseradish, sugar, bread-crumbs and sour cream. **HOLLANDAISE**—Yellow, like mayonnaise in appearance; hot. (*See Hollandaise*) **HOLSTEIN**—Same as Havraise. **HORSERADISH SAUCES**—*See Horseradish*. **HOMARD**—Lobster in small pieces, with lobster coral in butter sauce. **HUITRES**—Oysters in white or brown sauce. **INDIENNE**—Tomato with curry, anchovy, lemon juice. **ITALIAN**—Brown or white. Espagnole or veloute with chopped mushrooms, shallots, parsley, white wine. **JAMBON**—Brown sauce with shredded ham, butter and shallots lightly fried. **JOINVILLE**—Fish, orange colored. The fish broth made into butter sauce with yolks, lobster butter and lemon juice. **JOLIE FILLE**—White chicken sauce with hard-boiled yolks, bread-crumbs, butter, parsley. **KARI**—Curry sauce, same as *Indienne*. **KIRSCHWASSER SAUCE**—Sweet. Either cream or syrup flavored with kirsh. **KITCHENER'S (DR.) BOTTLED SAUCE**—Mushroom catsup 1 pt.; claret 1 pt.; walnut or lemon pickle  $\frac{1}{2}$  pt.; pounded anchovies 4 oz.; fresh lemon peel, horseradish, shallots each 1 oz.; black pepper and allspice each  $\frac{1}{2}$  oz.; cayenne and braised celery seed each 1 drachm; in a wide-mouthed bottle for 2 weeks, shaken daily, strained, bottled. **LEMON**—Sweet. Either custard or syrup flavored with lemon. **LIVOURNAISE**—Cold, for fish. Mayonnaise, pounded anchovies and parsley. **LOBSTER**—Butter sauce with anchovy essence and lobster meat. **LYONNAISE**—Rings of Bermuda onions lightly fried, added to brown tomato sauce. **MADEIRA**—Brown; espagnole with tomato sauce and madeira wine. **MADEIRA, SWEET**—Yolks, sugar, wine, lemon rind, stirred over fire till thick. **MAITRE D'HOTEL**—*See Maitre d'Hotel*. **MALTAISE**—Brown; fine herbs mixture, sherry and orange rind in the meat pan gravy. **MARINADE**—White; thickened broth with onions, parsley, aromatics, vinegar. **MARRONS**—*See Chestnut Sauce*. **MARROW**—Beef marrow in slices added at last to brown sauce. **MATELOTE**—*See Matelote*. **MATRIMONY SAUCE**—For dumplings; brown sugar, vinegar, water, butter and flour boiled, thicker than syrup. **MAYONNAISE**—Cold, yellow, salad sauce. (*See Mayonnaise*.) **MEDICIS**—Sweet; chocolate-flavored Bavaroise made thinner with cream; cold. **MILANAISE, WHITE**—Cream sauce with grated Parmesan. **MILANAISE, BROWN**—Brown sauce with mustard. **MINT**—Cold; fine-cut mint, vinegar, water, sugar. **MIRABEAU**—White garlic sauce; boiled garlic passed through a seive, mixed in butter sauce and glaze. **MIREPOIX**—*See Mirepoix*. **MORELS SAUCE**—Brown, like mushroom sauce. (*See Morels*.) **MOULES**—Mussel sauce. **MUSHROOM**—Brown; mushrooms stewed in butter, espagnole and tomato sauce added, and wine, lemon juice and parsley. **MUSHROOM PUREE**—White, mushrooms chopped, stewed in butter, passed through a seive. **MOUSQUETAIRE**—Cold; mustard, oil, tarragon vinegar, shallot, salt, cayenne. **MOUTARDE**—Mustard sauce. **MUSSEL**—Boiled mussels in Hollandaise; like oyster sauce. **MUSTARD SAUCE**

## SAU

—Mustard mixed in butter sauce; for broiled fish. **NANTAISE**—Cold, light green; pounded lobster mixed with ravigote sauce. **NAPLES**—For fish; cream sauce containing shrimp, anchovy, shallots, capers, flavor of garlic, lemon juice, cayenne, mace. **NAPOLITAINE**—Brown; espagnole with currant jelly, port wine and sultana raisins. **NEAPOLITAN**—Brown; espagnole, currant jelly, port wine, horseradish, ham and Harvey sauce. **NICEOISE**—Cold; yellow with green, like remoulade. Made with hard-boiled yolks, raw yolks, mustard, oil, vinegar, chives, parsley. **NONPARIEL**—Yellow, for fish; Hollandaise mixed with lobster-butter, red lobster, mushrooms, hard-boiled whites, and truffles. **NORMANDE**—Yellow, creamy; fish broth and oyster liquor thickened with roux and yolks. (*See Matelote Normande*.) **ONION**—Four varieties; onions in brown or white sauce; onion purées white or brown. **ORANGE**—For ducks; brown sauce with orange juice and shredded peel. (*See Bigarade*.) **ORANGE, SWEET**—Yellow custard with starch or flour, orange juice and rind, and curaçao. **OUDE SAUCE**—For cold meats; lightly fried onions in butter, tomato sauce, chillies, piece of dried haddock in shreds, lemon juice and water, stewed together, used cold. **OYSTER**—Sauce poulette with oysters. **OYSTER CRAB**—Sauce poulette made of fish broth, oyster crabs added. **PARISIAN**—*Maitre d'hotel* butter with shallots and beef extract added. **PARISIAN, SWEET**—Sherry, sugar and yolks whipped over fire, cream added. **PARSLEY**—(1) Chopped parsley in butter sauce. (2) Parsley juice and purée in butter sauce. **PEPPER**—Brown; espagnole with addition of water of boiled peppercorns and vinegar. **PERIGEOUX**—Brown, truffle. (*See Perigeux*.) **PERSIL**—Parsley sauce. **PERSILLADE**—A green ravigote of chopped parsley, chervil, tarragon, mustard, oil, lemon juice, salt, stirred together. **PIQUANTE**—*See Piquante*. **POIVRADE**—*See Poivrade*. **PLUM**—Prunes cooked in wine with cinnamon, mixed with espagnole. **POLONAISE**—White sauce with thick, sour cream added, horse-radish, lemon juice, and chopped fennel; for steaks, etc., in Polish style. **POOR MAN'S**—Broth thickened with brown roux, tomato catsup, essence of anchovy. **PORT WINE**—Brown, for game, etc.; same as *bourguignone*, with port wine. **PORTUGAISE**—Butter, yolk of eggs and lemon juice. **POULETTE**—*See Poulette*. **PRAWN**—Butter sauce tinted with lobster coral and prawns. **PROVENCALE**—Both white and brown. (1) White sauce with wine, tomatoes, garlic, mushrooms and capers. (2) Espagnole with tomatoes, onions, garlic, mushrooms. **PUDDING SAUCE, CAREME'S**—This appears under several different names; it is Madeira, sugar and yolks whipped to froth over the fire; allowed approach the boiling point, but not boil. **PUNCH SAUCE**—Sweet; butter sauce with lemon, yolks, sherry and brandy added; whipped over the fire. **RAVIGOTE**—The name relates to the mixture of green herbs (*see Ravigote*) which may be either in oil and vinegar or in mayonnaise. **REMOULADE**—*See Re-*

## SAU

*moulade*. ROBERT—Name of a Paris restaurateur of Rabelais' time, whose specialty this sauce was; brown; espagnole with fried chopped onions, mustard and glaze or beef extract, onions not strained out. ROMAIN—A sort of mincemeat eaten with fish, being currants, raisins, Italian pignoli nuts (like small almonds), sugar, vinegar and brown sauce. RASPBERRY—Sweet. (1) Raspberry juice and sugar added to whipped cream. (2) Raspberry syrup slightly thickened with starch. RATAFIA SAUCE—Sweet; syrup thickened with starch, flavored with lemon and ratafia liqueur. RAIFORT—Horseradish, cream and vinegar. REGENT'S—Sweet; vanilla yolk-of-egg custard with rum. RICARDO—Same as salmis sauce. RICHELIEU—White game-sauce with onions and wine. ROE SAUCE—Fish; soft roes cooked, pounded, seasoned, mixed with butter sauce and little vinegar. ROYAL—Another name for Hollandaise. ROYAL SAUCE—For fowls; purée of chicken, seasonings, bread panada, cream and yolks stirred over fire together. SAUCE A LA Russe—A white sauce with horseradish, vinegar, yolks and cream. RUSSIAN SAUCE—Hot; shallots, lean ham, herbs, stewed in butter; horseradish, sugar, vinegar, wine, white sauce and yolks to thicken. RUSSIAN—Cold; horseradish, mustard, sugar, vinegar, salt. SABAYON—Sweet; this also has half a dozen names; it is the same as Carême's pudding sauce above, with cream added and whipped with it. SAGE SAUCE—For roast goose or pork; brown gravy in roast-pan with chopped sage. SAINTE-MENEHOULD—Cream sauce with chopped parsley and mushrooms. SALMIS—The bones and trimmings of birds stewed with wine, espagnole, aromatics, and sauce strained off. (*See Essence of Game, Fumet.*) SAXONY—Fish; butter sauce made of the fish broth, (*see Roux*), shallot, mustard, white wine, shredded lemon. SCALLOP SAUCE—Boiled scallops and their liquor added to butter sauce with lemon juice. SHALLOT—Light brown; for ducks, pig, game; gravy from baking-pan with chopped shallots stewed in wine and butter added. SHALLOT SAUCE, MILD—Boiled shallots minced and put in butter sauce. SHARP SAUCE—For cutlets; shallots simmered in butter and vinegar, flour, broth, gherkins, parsley, pepper, salt. SHRIMP SAUCE—(1) Cream sauce with cut shrimps. (2) Butter sauce with anchovy essence and lemon juice and shrimps mixed in. SHRIMP AND ASPARAGUS SAUCE—Butter sauce with shrimp butter, shrimps and asparagus points. SICILIENNE—Fried onions in rings in espagnole and marsala wine. SORREL SAUCE—Stewed sorrel like spinach mixed with either white sauce for boiled meats or brown sauce for roast. SOUBISE—Purée of onions, white, with butter and milk, salt, pepper, nutmeg, pinch of sugar. SOY—An East Indian bottled sauce; it is made of purple wrinkled morels, galangal root and spices. SOYER'S—A bottled sauce. SULTANA—For game; sultana raisins in game gravy with port wine. SUPREME—Cream sauce made of chicken broth, butter, flour, essence of mushrooms and boiled cream.

## SAU

TARTAR—Mayonnaise with mustard, minced gherkins, capers, chervil and parsley. TEXIENNE—Same as Creole courtbouillon. TOMATO—Tomatoes passed through a strainer, stewed down thick, variously seasoned and compounded. TRUFFLE SAUCE—Sliced truffles fried in butter, espagnole, wine, lemon juice. (*See Perigieux.*) TORTUE—(1) Turtle sauce for calf's head; brown; espagnole with tomato sauce, aromatics, and sherry. (2) Veal brown-gravy with shallots, basil, thyme, sherry, lemon juice and rind and cayenne. VANILLA—Sweet; yolk-of-egg custard flavored with vanilla. VELOUTE—The sauce which is termed "white sauce," yet is not cream sauce. It is the stock white sauce of which other sauces are made; it is seasoned broth thickened with white roux, is fuller flavored with the vegetables, etc., in the broth than butter sauce which is made with water, yet has not so much butter. When *veloute* is further enriched with butter and glaze, and has egg yolks to make it creamy, it becomes Allemande, which is finished with a little lemon juice. VERTE—Green sauce; ravigote. VENITIENNE—For fish; white sauce made of seasoned fish broth, yolks added, lemon juice, parsley. VERJUICE—For ducks; green grapes boiled and mixed in espagnole. VERT-PRE—For eels, pale green; purée of spinach, chives and tarragon mixed with white ravigote sauce. VILLEROI—White sauce flavored with mushrooms. VINAIGRETTE—Chopped shallots and parsley with an equal quantity of oil and little vinegar and salt; cold. WHITE SAUCE—Either *veloute* or plain butter sauce. WHITE WINE SAUCE—The broth of fish that has been cooked in wine and water, thickened. LA BELLE SAUCE—For fish; put  $\frac{1}{2}$  pt. of cream into a saucepan with  $\frac{1}{8}$  of a nutmeg shaved, *not grated*. Beat to a froth the yolks of 2 and 1 whole egg, put the cream over the fire, stir till it thickens, put in 12 oysters (raw) finely chopped, stir till the cream is quite hot and the oysters just set, then whisk in the eggs. Just let the sauce thicken, that is all; remove from the fire, whisk for a few seconds and then dress the fish with it after tasting it and seasoning with salt, or the salt may be added to the eggs. Garnish the fish with rings of apple dipped in flour and fried brown, alternated with half rings of lemon pickle. YORKSHIRE SAUCE—Orange sauce for ham; espagnole, currant jelly, port wine, orange juice and boiled rind cut in shreds. BOTTLED TABLE SAUCE—The recipe for making the genuine Yorkshire Relish is probably known only to the manufacturers. However, the following is said to yield a good imitation of that popular sauce: 1 oz. garlic, 1 teaspoonful cayenne, 2 tablespoonfuls Indian soy, 2 tablespoonfuls mushroom ketchup, and 1 pt. vinegar; boil altogether 10 minutes and strain, and bottle when cold. BOTTLED FISH SAUCE—The following recipe will be found to yield a good fish sauce:  $1\frac{1}{2}$  gals. port wine,  $\frac{1}{2}$  gal. walnut ketchup, 2 pts. anchovy sauce,  $\frac{1}{2}$  doz. lemons, 3 doz. shallots,  $1\frac{1}{2}$  oz. chillies, 2 oz. horse-radish, 1 oz. mace,  $\frac{1}{2}$  oz. mus-

## SAU

tard; boil, strain and bottle. **YOUR OWN TABLE SAUCE**—The following recipe will produce a good store sauce: 2 pts. port wine or claret, 2 pts. walnut ketchup, 2 pts. mushroom ketchup, 4 tablespoonfuls anchovy sauce, 2 oz. fresh lemon rind cut very thin, 2 oz. finely scraped horse-radish, 4 cloves garlic pounded, 1 tablespoonful pepper, 1 tablespoonful allspice, 1 teaspoonful cayenne, the same of celery salt, or bruised celery seed, 1 teaspoonful curry-powder; put all the ingredients into a stoneware jar, and shake it well twice a day for a fortnight; then let it stand, and strain it into small bottles for use. These quantities will make very nearly a gallon of sauce; it will keep for any length of time and is very strong.

**SAUCISSON** (Fr.)—Sausage.

**SAUER-KRAUT**—See *Cabbage*. Before cooking the sauer-kraut, it must be well washed in several waters, then well drained, and put in a braizing-pan, with a fine piece of streaky bacon, a few Frankfort sausages, some fat taken from the surface of the stock-pot, and a ladleful of white stock. Stew the sauer-kraut for 3 hours, letting it simmer gently all the time in a moderately heated oven; but the bacon and sausages will have to be taken out when done, and put aside to be dished around the sauer-kraut when the latter is served. **THE ALSATIAN WAY**—Quartered apples, fat salt pork and a clove of garlic are put in to stew with the sauer-kraut.

**SAUSAGES**—In Vienna a mighty fair is kept open on the green sward of the Wurstl-Prater, or Sausage-Park, throughout the spring, summer, and autumn months of every year. From April to October the Sausage-Park daily teems with diversions, music, and mirth. Excellent beer, and plain inexpensive edibles, are dispensed to the public at half a dozen spacious wooden pavilions, surrounded by scores of strong tables and chairs, amongst which meander the itinerant vendors of sausage, for the most part Italians, whose privilege of selling their toothsome wares in this part of the Prater first endowed the people's pleasaunce with its predicate of "Wurstl." From these active and vociferous merchants may be purchased every variety of the "farci-mentum" so dear to Germans and Italians alike, under the names of *mettwurst*, *salami*, *leberwurst*, *mortadella*, *bratwurst*, *blutwurst*, *Frankfurter*, and a dozen other sorts of highly-flavored, thirst-creating compounds of meat, spice, and garlic. **A CONSERVATIVE PUBLIC**—"Mutton Sausages. I have had the recipe for mutton sausages given me. It seems good and feasible; but I have not tried it yet. These sausages could be introduced into hotels and private families; but I would not recommend their introduction to the public through the medium of restaurants or shops. The public only admit the existence and possibility of five sausages at present; viz., pork, beef, German, saveloys, and black puddings, and they will look with great suspicion on the other fifty or sixty varieties if offered to them." **BOLOGNA**

## SAV

**SAUSAGE**—The sausages of Bologna, which are almost as highly appreciated as those of Strasburg, are made with 10 lbs. of fresh pork, chopped, and mixed with half the quantity of bacon, the whole being seasoned with salt, saltpetre, pepper, and herbs, and afterwards put in a well-closed bladder. The sausage is next steeped in brine for from 10 to 12 days. It is ready to eat after having been boiled for 2 or 3 hours. **HAMBURG SAUSAGE**—The famous sausages of Hamburg, which are known in all parts of Europe, and are made in large quantities, are manufactured from the lean flesh of the pig and the ox, chopped, and mixed together with fresh pork. **GERMAN SAUSAGE**—In making German sausage, a quantity of the second quality of pork—that which is well interlarded with fat—is chopped up; but not so finely as in the previous instances. It is then seasoned with parsley, cinnamon, bay-leaves, pepper—both in the grain and in powder—and spices. When the mixture is ready for filling, it is passed into skins prepared from the intestines of calves, and divided into sausages of about four inches in length. These are then exposed to smoke for a week, and, before being eaten, are boiled in water for half an hour. In some instances, pea-meal, the meal of French beans, and lentils, are used for mixing with the sausage-meat. Cochineal is also added by some makers, in order to produce the tint which is so well known. In the south of France, sausages of this kind are made with the addition of garlic. **THE FRENCH CREPINETTE**—The flat sausage, or *crepinette*, although it does not keep so well as the other kinds, is more delicious in its fresh state. It is made with the same mixture as that above described, but, instead of introducing the meat into the sausage-skin, it is enveloped in a piece of the caul of the pig. The sausage is flat and oblong in shape, and is either cooked upon the stove or the gridiron. **SWADDLED SAUSAGES**—Paupiettes; fresh pork-sausages fried, then each one rolled up in 6 or 8 young cabbage leaves, tied with thread, fried and turned in the sausage-fat for 20 minutes; drained; served on hot dish. **SAUSAGE AND POTATO RISsoles**—Small fresh pork-sausages fried, cooled; potatoes prepared as for croquettes; each sausage coated with potato, egged, breaded and fried. **SAUSAGE KROMESKIES**—Cold cooked sausages dipped into pancake batter, dropped in hot lard and fried brown. **SAUSAGE PATTIES**—Patty or "gem" pans lined with short pie-paste, half filled with sausage-meat, lid of paste put on, egged over, baked. **SAUSAGE PUDDING**—Put  $\frac{1}{2}$  lb. beef-sausages into a buttered pie-dish and pour over them this batter: One egg,  $\frac{1}{2}$  lb. flour, 1 pt. milk,  $\frac{1}{2}$  teaspoonful baking-powder; bake 1 hour. **SURPRISE SAUSAGES**—Take large raw potatoes, cut out a cork-shaped piece and remove part of the inside sufficient to contain half a sausage divested of its skin, and bake till done. (*See Potatoes, Georgette [a la], and Bignon.*)

**SAVARIN**—Brillat Savarin, noted as the author of the *Physiologie du Gout*, or Gastronomy as a Fine

## SAV

Art. He was a French advocate, contemporary with Carême, De Cussy, Dr. Joseph Roques, and the last notable coterie of French writers on gastronomy. He died at the age of seventy-one, of a cold caught at Louis XVIII's funeral.

SAVARIN CAKE—A yeast-raised cake, not different from *baba*, except in the decoration of the mould with almonds; after baking, the cake is saturated with orange-syrup or wine and curacao. SAVARIN-CAKE WITH STRAWBERRY-SAUCE—"A delicious entremets just now in the strawberry season in Paris: Cook 20 little savarin-cakes in dariole moulds, and, as they come out of oven, dip them in syrup flavored with lemon and orange-peel; let syrup run off, mask them with an icing of powdered sugar diluted with strawberry-juice; build them up on dish into a pyramid, and send them to table with a purée of strawberries, diluted with vanilla-flavored syrup."

SAVELOY—A popular variety of sausage ready-cooked; it is reddened with saltpetre; made of 2 lbs. saltpetre-pickled pork, 6 oz. bread-crumbs, 4 sage-leaves, 1 teaspoonful pepper; filled into skins and boiled.

SAVORY—One of the seasoning herbs; can be grown in any garden; is far better green than in the dry powdered state as found at the stores; can often be obtained in regular supply from the market-gardeners. There are two varieties, the summer and winter savories, both fragrant and most excellent for soups and stews.

SAVOY CABBAGE—A variety of cabbage with curly or crimped leaves.

SAVOY CAKE—Sponge cake; called by the French, *biscuit de Savoie*.

SCALLOP—A bivalve; a larger sort of cockle, white; shipped like oysters in bulk without the shells, and obtainable at the fish-markets. Can be cooked in many of the same ways as oysters, fried, scalloped, in soups. SCALLOPS A LA BRETOISE—Cook the scallops in a little white wine and broth; cut a few eschalors in small dice, fry them in butter, add the liquor of your scallops, strew fresh bread-crumbs and the spawn of a lobster, chopped parsley, salt, pepper, and a piece of fresh butter; fill some scallop-shells with the mixture, cover with grated bread-crumbs, sprinkle a little melted butter over each, and bake in a hot oven. DEVILLED SCALLOPS—Like Philadelphia devilled oysters, minced. Take a hundred of them and place, sharp edges downwards, in a large saucepan; add a pint of water; cover the pot, and set over a brisk fire; as soon as the shells open, they are ready for further treatment. When cool, mince the flesh of the shell-fish finely; add bread-crumbs, a piece of butter, pepper, fine herbs to taste, and mix the whole together with enough of the liquor from the scallops to make a stiff batter; fill the shells of the largest of them with the mixture, cover the top with fine bread-crumbs, moisten with melted butter, and place in a brisk oven until they are nicely browned.

## SCO

SCALLOP SHELLS—Metal shells, silver, or plated, granite ware, or tin. They are made in the form of natural scallop-shells, that being the handsomest shape for holding scalloped fish, clams, lobster, and all such dishes to be served hot in the shells. Can be found at the furnishing stores.

SCHMIERKASE—"Schmierkase has all the seasons for its own among the Pennsylvania farmers, but it is only in the fall that sauer-kraut and *lod-waerrick* get their work in. In the fall, too, *metzel-sup* is on the circuit, and many rise up gladly and clutch it." *Schmierkase* or *smearkase* is the cheese made for immediate use from the curd of sour milk. The "clabbered" milk must be heated to the boiling point, when the curd becomes solidified and the clear whey can be drained off by pouring the whole into a cloth and hanging it up to drip. May then be broken up and seasoned either with salt, pepper, and cream, or as a sweet dish with sugar or fruit. If pressed and kept, it ripens and can be made a good imitation of *Neufchatel*.

SCORPION OMELETTE—"A curious dish was prepared the other day for a British traveler in Mexico. The attendants served up an omelette, and the servants partook very heartily of the dainty morsel, but the traveler mistrusted the food owing to certain black particles mixed therein. Inquiring as to the nature of the suspicious ingredients, he could scarcely believe his ears when the reply was given: 'Oh, these are scorpions,' and an investigation proved this to be true, the lower orders in Mexico thus utilizing the young scorpions, which are dug out, hundreds in a nest, their sting being cut off before cooking."

SCOTTISH COOKERY—There is a demand pressed upon hotel-keepers and stewards for peculiarly Scotch dishes for annual celebrations more frequently than for those of any other nationality, and the following repertory will be found useful. For the benefit of your readers (writes Mac Haggis) I beg to send you the following recipe for GROUSE SOUP which is a most palatable *potage*. It is usually made from birds which have been *hashed* in the shooting, or *cheepers*. Let the grouse be plucked and drawn, joint them, and stew the pieces patiently in two or three pints of diluted soup-stock till they are tender. Put the backbones of the birds in another pot, and simmer till all the *virtue* has been extracted; then strain the liquor from each pot and mix it together, restoring to it the best of the joints. Give this a smart boil in another pan, season to taste with pepper and salt, add one knob of sugar and a glass of port-wine. If preferred, a little bit of carrot may be boiled in the compound—many persons add a slice of toasted bread cut into very small dice. This soup takes about two hours and a half to make ready. Perhaps some, however, would prefer to try the celebrated POTAGE A LA MEG MERRILEES, which used to be served at Abbotsford. This soup was "composed" by the then Duke of Buccleuch's

## SCO

*chef* at Bow Hill in honor of Sir Walter Scott. A couple of 'gray' hens or blackcock, an o'd grouse, or two or three *cheepers*, with a partridge or two, are necessary for this compound, but no stock is used. Cut up the birds, and stew them in as much water as is necessary for making into soup, reserving twenty or so of the fleshy bits for after-use. Put in the stewpan the heart of a small cabbage, a cut carrot, and a few large beans (about a dozen) which have had their skins removed; let them be all slowly stewed for three hours; keeping the lid of the pot close. When the time is about up for the stew being done, fry the reserved pieces quickly in flour and butter, p'ace them in another pot, and strain the liquor from the stew over them. Boil again, with a head of celery cut into very small bits; season with salt and a pinch of cayenne. The second boiling should last for an hour or so. *Note:* Mac Haggis is not sufficiently explicit about the frying "the reserved pieces in flour and butter," which cannot be done; but means *faire revenir* (*see Revenir*)—to fry the pieces in butter, then add flour, and after that the stock, which will be thickened by the extempore *roux* thus made. **SCOTCH HARE SOUP**—"While I am in my *batterie de cuisine*, I must give a formula for the making of hare-soup, as it is served on the best Scottish dinner-tables—a vastly different compound from what we are accustomed to in London. As much of the blood of the hare must be saved as possible; so that snared or coursed hares are the best for the soup-pot. Use a couple; cut one in joints, in order to make a stock; boil it in as much water as may be required for the soup, with, say, two heads of celery, an onion or two, and an apple pared and cored. If hares are scarce, boil 3 lbs. of leg of beef, bones and all, by way of stock; joint the second hare carefully, saving every drop of the blood, which pour into the stock, both being cold at the time of mixing, having previously strained it into a clean pan; set on the fire, and stir constantly till it boils; then add the joints of the hare, and keep the soup simmering till they are cooked, say in about 70 minutes; serve very hot, with a portion of the meat to each guest, taking care to give the head to a professed epicure. Sir Walter Scott used to say that hares were created to be made into soup." **SCOTCH HOTCH-POTCH**—"I may mention, too, that I am the happy possessor of a 'plain directions' for making 'hotch-potch' and 'cockie-leekie.' The first is made of a great variety of vegetables—grated carrot and chopped carrot as well, likewise a chopped turnip and a few small turnips, the heart of a small cabbage cut into shreds, plenty of green peas, as also a few beans (they must have been skinned); a teacup of cauliflower-heads, and a little parsley may also be used. The best meat to place in the pot is 4 lbs. of fresh lamb or mutton, cut into pieces or boiled whole, according to taste, but it is best cut into mouthfuls. All the green stuff required should be carefully cleaned. Let the soup be well boiled, and the cook should remember the useful seasoning of

## SCO

pepper and salt. Do not make more of this soup than can be consumed at one sitting; it is best when newly made. The cook should religiously bear in mind that the *potage* must not be boiled long enough for the vegetables to lose their individuality. Beef may be used in place of mutton." **SCOTCH COCKIE-LEEKIE**—"Is a very appetizing soup, and can be made, if necessary, without a fowl. It should be 'thick of leeks,' cut in small pieces, the rank tail-ends being dispensed with, and the leeks ought to be well cleaned and the roots carefully removed. Three or four pounds of leg of beef will make a good foundation; boil in as much water as may be necessary till the meat is in rags, a couple of big leeks being boiled with it. Strain off the liquor and place in it, cut up in small portions half a dozen or more big leeks, which boil till ready. If you have a fowl, cut off the fleshy parts and cook them till done in the soup, having previously used the carcass in making the stock. The compound, seasoned to taste, ought to be 'thick and slab,' therefore grudge not the leeks." **A KETTLE OF FISH**—"A Tweed kettle, of course, which is 'par excellence' *the* kettle. First procure your salmon, empty it, and trim off the rougher parts of the fins; then wash the inside of the fish well with pure cold water, and cut it across from shoulder to tail into many slices, each being about three quarters of an inch in thicknes. Your kettle (or pot), with the necessary quantity of water (enough to cover the cut-up salmon, and to allow of a little 'boiling in,' as also of a helping of the liquid to each slice of the fish, as well as to admit of a portion being left in aid of the next kettle), should be on the fire, and the water boiling merrily. Pop the slices of salmon into the kettle, and let them cook for fully twelve minutes; and remember this, the water in which you boil your fish can scarcely be too salt—in fact, it should be as brine. Long ago, on the Tweedside, when 'the kettle' was a greater institution than it is now, a portion of the water in which one fish was boiled was preserved as a foundation for the boiling of its successor. At Abbotsford, when a kettle was served on Sir Walter's fishery, the usual accompaniment to it was oat-cakes and flour-scones well buttered, no sauce being thought of other than that with which the 'venison of the waters' had been boiled, with pe. haps a drop or two of vinegar." **SCOTCH BROTH**—A Scotch Recipe. Put a teacupful of pearl barley into four quarts of cold water, let it boil, add 2 lbs. of scrag of mutton or thin flank of beef, two onions, two turnips, two carrots cut in dice, and one carrot grated; boil slowly for three hours; add salt and pepper to taste before removing from the fire. **KALE BROSE**—Boil an ox-heel in three quarts of water, letting it gently simmer for four hours. Shred two large handfuls of greens or sea-kale, put them into the broth, and when sufficiently cooked stir  $\frac{1}{2}$  pint of toasted oatmeal into a little of the fat broth in another vessel, add it to the rest, season with pepper and salt, boil all, serve hot. **HOWTOWDIE**—Truss a young fowl as for

## SCO

boiling. Place in a stewpan 4 oz. butter, and when the latter is quite hot, place the fowl in stewpan, and allow it to brown nicely all over, turning it round so as to facilitate this. When brown, place a bouquet garnie, seasoning of salt, pepper, three cloves, three small onions in the stewpan with the fowl; pour  $\frac{1}{2}$  pint of good stock over, and simmer gently for half an hour. Now turn the fowl over, add  $\frac{1}{2}$  pint more of good stock, simmer another half hour. Have ready some spinach, nicely cooked and seasoned, some rice plain boiled, and put in small moulds, and some sliced truffles. Lay the fowl on dish; the gravy will now be a rich glaze; pour the gravy over the fowl; arrange spinach in small pieces, or a border of it, turn the rice out of the cups, and arrange little distances apart on the border of spinach; lay a nicely-shaped piece of truffle on the top of each shape of rice. This is a very old and palatable Scotch dish. **MINCE COLLOPS**—1 lb. best rumpsteak minced fine. Place 2 oz. butter in a pan, and stew the meat for ten minutes; then add salt, pepper, and  $\frac{1}{2}$  pint water; simmer very gently for over an hour; add a dessert-spoonful Worcester sauce, and the same quantity of flour, mixed in a tablespoonful of water; boil for two minutes; serve with sippets of toast and Swiss eggs. **SWISS EGGS**—Butter small moulds sprinkled with finely chopped parsley, pepper, and salt; break some eggs, place one in each mould, being careful to see that the yolk is in the center of mould, cover the moulds with buttered paper, and steam for five minutes; turn out of mould, when the parsley has a very pretty effect, all over the white of egg. **SCOTCH EGGS**—Take  $\frac{1}{2}$  lb. cooked ham or chicken, finely minced and seasoned, mixed with 2 oz. breadcrumbs, and one well-beaten egg; form into oval balls, rather larger than an egg, egg and breadcrumb, and fry in hot fat; drain, and cut in half; scoop out a small hollow in the center of each half, and place the half of a hard-boiled egg in each piece of croquette, press well down so as to be level with meat, have little rounds of buttered toast or fried bread, place each Scotch egg on a round, and serve garnished with fried parsley. **SCOTCH SHORTBREAD**—1 lb. flour,  $\frac{1}{2}$  lb. butter,  $\frac{1}{2}$  lb. sugar, the yolk of one egg. Mix the ingredients together, and work very well for quarter of an hour. Roll out to one inch in thickness, cut in squares, pinch round edges, ornament with peel or comfits. Bake in very moderate oven for half an hour. The oatcakes are made of very fine oatmeal, water, salt and a little baking powder; they are baked in a moderate oven, and are very crisp; it is quite a mistake to mix fat or butter with oatcakes. If nicely prepared without fat, they are quite crisp, and far more wholesome than when fat is used. **SCOTCH WOODCOCK**—Take three slices of bread, about half an inch thick, remove crust and toast quickly; butter on both sides and spread anchovy-paste thickly on one side only; place these on a hot dish, cover, and keep warm while you prepare the sauce. Beat the yolks of four eggs, with a pinch of

## SCO

cayenne pepper, until they are smooth and creamy; pour over, stirring all the time, one large cupful of hot cream; return to the saucepan, and stir briskly until the sauce thickens, and then immediately pour over the toast, and serve hot. Be very careful not to let the sauce boil, or the yolks will curdle. **SCOTCH OATMEAL PORRIDGE**—Half fill a small pot with boiling water. Fill your left hand with medium fine oatmeal. Trickle it slowly through your fingers into the water. Keep stirring this with a spurtle (*Anglice*, a stirring stick), that no particles may stick to the bottom, and add half a teaspoonful of salt. Add oatmeal till the mixture is of the consistency of treacle. Leave it on the fire three minutes longer, stirring all the time—in all ten minutes. All the starch-cells will then, (with this fine cut of oatmeal) be burst open. Lay out five small soup-plates on the table, the usual quantity in a family. Catch hold of the bow of the pot with a cloth beneath your hand. Pour out the quantum into each plate, using the spurtle to hold the pot in position. Leave standing three minutes to solidify and cool. Supply a bowl of sweet milk to each. Half fill the spoon with porridge, dip it into the bowl to fill the other half with milk, and you will have an article of diet surpassed by none in giving you brain, vigor health of mind and body. Porridge made from round oatmeal is best, but it requires twenty-five minutes' cooking before the starch-cells are all burst open. It is, however, worth the trouble. **SCOTCH OATMEAL CAKES**—Put a small teacupful of water into a large bowl. Dissolve in it three-fourths of a spoonful of baking soda (bicarbonate of soda). To the solution add oatmeal till of the consistency of dough. Be quick, or it will dry and toughen. Have two baking-boards 18 inches by 18 inches. Place the ball of wet oatmeal on one of them, sprinkling dry oatmeal beneath to prevent it adhering. Roll this ball out with a  $2\frac{3}{4}$ -inch roller. Brush all the dry oatmeal clean off, cut off the ragged edges, place the other board above, reverse and lift the former board. A girdle is hung on the fire. This is a circular sheet of sheet-iron, 18 inches in diameter. Let the elongated cake of oatmeal slip from the baking-board on to the girdle. Cut the cake in four. Repeat the operation with another cake. When half done, turn the four cakes on the girdle, as they will by that time be "done" on the under side. When ready with the second cake, lift off the first four cakes and place them before the fire to dry, as by that time they will be done enough. This, of course, has to be noticed. Regulate the height of the girdle from the fire according to the heat. Remember the old rhyme that King Alfred forgot—

"The bannocks are burnin',  
And ready for turnin',"

and you will have from the ordinary sweet, fine Scotch oatmeal a well-flavored and wholesome cake. Fresh, newly made butter added to this and a finnon haddock will make a very palatable break-



## SCO

fast. These two articles of food have been the principal cause of the energy, the vitality, the force, the vigor, the virility, the simplicity and the ability of the Scotch character. **SCOTCH PUDDING**—To one quart of well-cooked barley add six ounces of sifted sugar, mix both together with one quart of milk in a stewpan, then add four ounces of fresh butter, a pinch of salt, the rind of a lemon rubbed on sugar, and a wineglassful of whisky. Stir the whole on the fire until it boils, and then work the batter perfectly smooth; next work in six yolks of eggs, and then lightly mix in six whites of eggs whisked into a firm froth; pour the batter into a slightly buttered pie-dish and bake the pudding in moderate heat. **SCOTCH HAGGIS**—Take the stomach of a sheep, wash it well, and let it soak for several hours in cold salt and water, then turn it inside out, put it into boiling water scald, scrape it quickly with a knife, and let it remain in water until wanted. Clean a sheep's pluck thoroughly. Pierce the heart and the liver in several places, to let the blood run out, and boil the liver

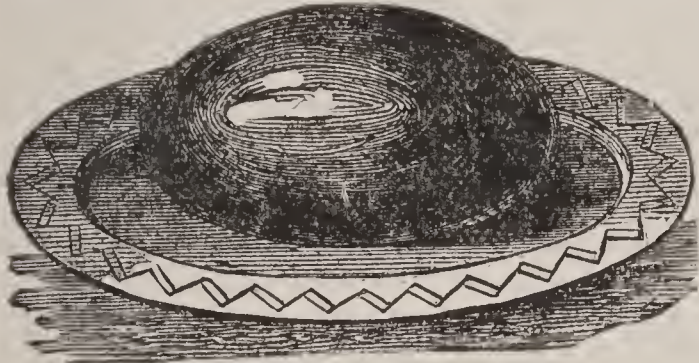

THE HAGGIS.

Fair fa' your honest sonsie face;  
Weel are ye worthy o' a grace  
As lang's my airm.

and lights for an hour and a half. When they have boiled a quarter of an hour, put them into fresh water, and, during the last half hour, let the rest of the pluck be boiled with them. Trim away the skins, and any discolored parts there may be, grate half of the liver, and mince all the rest very finely; add a pound of finely-shred suet, two chopped onions, half a pint of oatmeal, or, if preferred, half a pound of oat-cakes, toasted and crumbled, two teaspoonfuls of salt, and one of pepper, half a nutmeg, grated, and a grain of cayenne. Moisten with half a pint of good gravy and the juice of a small lemon, and put the mixture into the bag already prepared for it. Be careful to leave room for swelling, sew it securely, and plunge it into boiling water. It will require three hours' gentle boiling. Prick it with a needle every now and then, especially during the first half hour, to let the air out. A haggis should be sent to table as hot as possible, and neither sauce nor gravy should be served with it. The above is sufficient for eight or ten persons. **A SCOTTISH BILL OF FARE**—Dinner given by the Scottish Society of Sheffield, at the Clarence Hotel in that town, to commemorate the anniversary of the poet Burns: The Præses wi' admonition due will say the "Selkirk Grace."

## SCR

Some ha'e meat that canna eat,  
An' some wad eat that want it;  
But we ha'e meat an' we can eat,  
Sae let the Lord be thankit.

**THE DENNER**—*First Roun'*—Cock o' Leekie. Clear Turtle. Scotch Broth. *Second Roun'*—Salmon, Fennel Sauce. Frizzled Smelts, Sauce Tartare. Bristled Glesca' Magistrates. *Third Roun'*—Scotch Collops. Calf's Heid an' Mushrooms. Stewed Kidneys a la Champagne. *Fourth Roun'*—The Pibroch will soun' the approach o' *The Haggis*. A wee drap o' Talisker. *Fifth Roun'*—A bit wee lambie an' a bit o' its Mither. Sirloin o' Beef. Tatties Biled an' Chappit. Bashed Neeps. *Sixth Roun'*—Roastit an' Biled Bubbly Jock. Roastit Deuks an' Hens. Tung an' Grumphy a la Champagne. *Seventh Roun'*—Some sma' Birds. Roastit Pheasants an' Muir Fowl. *Eighth Roun'*—Cabinet Puddin'. Lemon Puddin'. *Ninth Roun'*—Sultane, French Pastry, Compote of Rhubarb, an' Orange, Greengage an' Apple Tairts, Charlotte Russea n' Raspberry Creams, Custard, Meringues a la Creme, Noyeau an' Maraschino Jellies Trifle, wi' ither sunkets couthie to the kyte. *Dessert*—Pineapples, Grapes, Apricots, Pears, Oranges, Apples, Filberts, Walnuts, etc.

We thank Thee for these mercies, Lord,  
Sae far beyond oor merits;  
Noo, waiter lads, clear aff the plates,  
An' fesh us in the spirits.

Wines, etc. (List on the Table). But nane need drink that are na dry. **CURLER'S PUDDING**—“At a supper recently served at the Caledonian Hotel, Oban, to the local Curling Clubs, Mr. and Mrs. Craig Watt (the worthy host and hostess) created a welcome surprise by including in the bill of fare a “Curlers' Pudding,” a novelty not less delicious to the taste than singular in appearance. There were two of these puddings, one at each end of the table, exactly the size and color of a pair of curling stones, resembling polished Ben Cruachan granite, and surmounted with a pair of real handles. **A “CALF” DINNER**—At a dinner given by Lord Polkemmet, of the Scottish Bar, his guests saw, when the covers were removed, that the fare consisted of veal broth, a roasted fillet of veal, veal cutlets, a veal pie, a calf's head, and calf's-foot jelly. The judge, observing the surprise of his guests, volunteered an explanation. “Ou, ay, it's a cauf; when we kill a beast, we just eat up ae side, and down the other.”

**SCONES**—Scotch name for baking powder biscuits. There are also soda scones, or biscuits, graham scones, etc.

**SCOTCH BUNS**—Made like dumplings, the outside being light dough made as for French rolls, with a good allowance of butter in it, the filling a walnut-sized ball of currants, raisins, almonds, citron and spice stuck together with enough butter and flour. The dumplings, flattened a little, are notched on the side, allowed to rise, egged over, and baked. (See *Simmels*.)

**SCRAG OF MUTTON**—The real neck. The neck of mutton, or lamb, or veal mentioned so fre-

## SCR

quently in cook-book directions generally means what in this country is called the rack, the best part of the ribs which furnishes the shapely cutlets.

SCRAPPLE—Domestic and local name, credited to Pennsylvania, of a mixture of head-cheese and cornmeal boiled together, and when cold cut into slices and fried.

SCUPPERNONG—A large Southern wild grape. Good for making wine. Comes to market as loose berries, like plums, and not in clusters; not choice for the table.

SEA COW—The flesh of the sea-cow, found in the vast rivers of Brazil, resembles fresh pork, and is excellent. Sausages are made of it and sent to Portugal as a great delicacy.

SEA KALE—It is well known that this popular vegetable is used in a forced and always blanched state. It is a native of the seashore and cliffs of the south and west coasts of England. "For centuries before it was known, as now, at the tables of the great and wealthy, it was an object of special regard in the humble dwellings of the south coast fishermen. Clambering up the cliffs, and swinging themselves by means of ropes over precipitous heights, they encountered any amount of danger to obtain, in spring, the tender shoots of that delicious vegetable as they were just emerging from the sand and shingle in which they grew." It is cooked in the usual way for greens and cabbage, generally boiled with bacon.

SEA TROUT—An American sea-fish, speckled and otherwise resembling a brook trout, yet not of the salmonidæ family. Common and plentiful, from 1 to 2 pounds weight.

SEA-URCHIN—"Another radiate, and the only other one of this class that I know to be eatable, is the *Echinus*—the sea-urchin, or sea-egg. This animal carries a system of channels and membranes in a hollow globe of flinty, but brittle texture, covered by spines, like a miniature hedgehog well rolled up. Examine one when it holds no eggs, and you will find nothing eatable about it, inside or out. Whatever the season, however, but especially in summer, a large proportion of them will contain several bunches of orange-yellow eggs so minute that the whole contents of a big *echinus* will not fill a dessert-spoon. These eggs taste like an oyster, and are nutritious; they call for no cooking, and are easily got at. Thus they have always been fed upon as a relish by half-refined coast people like those of Eastern Asia and its neighboring islands, and by the well-supplied Indians of Puget Sound and British Columbia, and have proved the stand-by of miserable savages whose desolate homes afford them little else to maintain life. The Neapolitan poor are not as a rule dainty, but, while delighting in sea-urchin, they look down with scorn upon the Calabrese, because they eat sea-slugs, which, if properly cooked, are not very bad."

SEA-SLUG—See *Beche de Mer*.

## SHE

SEED CAKES—Plain and cheap sorts of cakes flavored with caraway seeds. (1) Made of 1 lb. butter, 1¼ lb. sugar, 8 eggs, 3 lbs. flour, 6 teaspoons powder, 1 oz. caraway seed, 1½ pts. milk, 3 oz. citron chopped fine; baked in moulds. (2) 1 lb. sugar, ¾ lb. butter, 5 eggs, 3¾ lbs. flour, 6 teaspoons powder, 1 qt. milk, lemon extract and ½ oz. caraway seeds; baked in small moulds.

SEMOLINA—Known in this country as farina; it is the same thing made from wheat that fine hominy "grits" is from corn. (See *Farina, Soups*.)

SERVIETTE (Fr.)—Napkin.

SHAD—American sea-fish; an early spring luxury. It enters the rivers in immense shoals, the southern rivers first and those further northward in succession as the season advances, where it is taken and shipped to all parts of the country. The shad rarely exceeds 4 lbs. weight, it tastes like fresh herring, is best broiled, but is cooked in a variety of other ways. The one drawback is the abundance of small bones in its flesh. When to be broiled, or opened and stuffed, the back-bone should be removed and then the rib bones drawn out with the fingers, which will be found an improvement and facilitates the carving of the fish. BROILED SHAD A LA CLERMONT—Split down the back, the spine removed, the fish steeped an hour in oil and lemon juice, broiled, doubled to its original shape, served with fried oysters and fried pieces of shad roe around and *maitre d'hotel* sauce. ALOSE A LA MAITRE D'HOTEL—Shad cooked as above, served flat as it is, broiled, with the sauce and parsley and lemons.

SHAD ROES—See *Fish Roes, Laitances*.

SHADDOCK OR "GRAPE FRUIT"—The shaddock is a handsome, though scarcely a delicious, addition to our dessert fruits; the flavor of its juice being a sweetish acid, intermediate between that of the orange and the lemon, with rather a bitter taste. It may not be generally known that the best marmalade is produced from the shaddock, a sort of cross between the orange and the lemon, and named after a Captain Shaddock, who first brought it from China, or, as some say, from Guinea, and planted it in the West Indies, whence we derive our limited supply.

SHALLOT—That variety of onion which grows from a bunch of roots and does not form one compact bulb. It brings the earliest spring onions, the roots being divided and planted singly. Is oftenest named in cooking directions, as it is the mildest flavored of the onion tribe.

SHARK—In Havana the shark is sold as food in the open market. The almond-eyed heathen Chinese loves shark's fins cooked with bamboo shoots.

SHEEPHEAD—An American sea-fish of excellent quality. Its name is misleading, unless spelled as above, to those who do not know that actual sheeps' heads are not eaten in the United States. It

## SHE

is very generally spelled sheeps-head in the North and sheephead in the South; the latter is the right way, as it is not a sheep's head, but a sheep-headed fish, the resemblance consisting in its having rows of front teeth and a sheep-like mouth. It is best cooked by boiling.

**SHEERAH**—"I remember one day at a *chapar-khana* in Persia the *chapar-jee* said he could provide me with both eggs and *sheerah*. *Sheerah* is a sort of thin molasses made from sweet grapes. He seemed a pretty intelligent sort of a young man, so I contented myself with telling him to go ahead and cook the eggs. When supper-time came round the salaaming *chapar-jee* presented himself with a low obeisance and served the eggs—scrambled in the molasses!"

**SHRIMP**—The true shrimp is much smaller than the prawn, which is called shrimp in the United States, and therefore not so suitable for cooking purposes, but is tenderer and of finer flavor and hence better as a relish for breakfast or tea. It is of a reddish brown color after boiling, the prawn a light pink. **SHRIMPS FRIED IN THEIR SHELLS**—Are very delicious; like whitebait, but richer. Should any epicurean reader desire to try this dish, he should fry the shrimps, as they come from the sea, not as they are sold by the fishmonger, these being already boiled in salt water. **SHRIMPS BOILED**—"Anent those tasty *hors d'œuvres*, shrimps, it may be well to note that their flavor is immensely improved by adding 2 or 3 glasses of sherry or other white wine to the water in which they are boiled." **SHRIMP CROQUETTES**—A novelty; are now introduced in the fish course by fashionable caterers. **SHRIMP ROLLS**—Cut some thin slices of bread and butter from a tin loaf, which must be fresh, but not too new, or it will not cut well. Cut off the crust, and on each slice sprinkle a few shrimps, from which the shells have just been taken. Roll up each slice, taking care to keep them just one size, build them up on a napkin, and garnish with little sprigs of parsley. **ESSENCE OF SHRIMPS**—"At the bay shrimps of excellent flavor are caught in abundance, and one resident does quite a trade in potting and converting them into 'essence.' Let those who swear by 'anchovy' as a fish relish or sauce try essence of shrimps, and we fancy they will not forsake it thereafter."

**SHRUB**—Name of a mixture of fruit syrup and spirit. **RUM SHRUB**—A mixture of 2 qts. rum with 1 qt. lemon syrup.

**SIMNEL CAKES**—They are raised cakes, the crust of which is made of fine flour and water, with sufficient saffron to give it a deep yellow color, and the interior is filled with the materials of a very rich plum cake, with plenty of candied lemon peel and other good things. They are made up very stiff, tied up in a cloth and boiled for several hours, after which they are brushed over with eggs and then baked. In Shropshire where simnels are an institu-

## SME

tion, a curious legend attaches to them. An old couple named Simon and Nelly, so the story goes, used up the remains of the unleavened dough provided for the fasting season, and mixed with it some plum-pudding left from Christmas, and some eggs, and so made a cake for the Easter feast when their children visited them. It is said that the result was so appreciated that "Simon and Nelly Cake" became widely known; but the name was soon curtailed to "Sim Nell." As a presentation-cake nothing is more suitable than the Simnel, as, indeed, may be gathered from the following quaint rhymes in Harland's "Lancashire Legends."

The goode rounde sugarye,  
Kinge of cakes, a Symnelle

It speaks of deareste familye tyes,  
From friende to friende in Lent it hyes;

To all good fellowshippe yt cries,  
"I'm a righte trewe Symnelle."

Long may symbolique symnelle send  
Friende's everye lovyng to friende,  
From "Auld Lang Syne," till tyme shall ende  
The goode olde Symnelle.

**SIPPETS**—Little pieces of bread for soup. Bread cut in thin slices, then cut in small triangles, and dried or lightly toasted in the oven. Sippet is the English equivalent of *crouton*, but the latter word is more generally used to designate fried sippets.

**SKATE**—A flat and long-tailed fish of the ray family, common and cheap in French and English markets. **RAIE A LA MAITRE D'HOTEL**—Skate boiled and served with hot *maitre d'hotel* sauce. **RAIE FRITE**—Skate cut in fillets breaded and fried. **RAIE AU BEURRE NOIR**—Slices crimped and boiled served with black-butter sauce. **RAIE A LA NOISETTE**—Skate filleted and boiled; served in butter sauce with the pounded liver of the skate and tarragon vinegar. **RAIE AUX FINES HERBES**—A fricassee of skate, or white stew with mushrooms, shallots, parsley, butter and lemon juice.

**SMELT**—A small salt-water fish of delicate flavor when fresh, and emitting an odor which has been likened to the smell of violets, and, again, to the odor of freshly-cut cucumbers. It loses this perfume in a few hours, and when shipped to western markets as it is in boxes of convenient size, like crates of fruit, it becomes a very commonplace fish by the time it reaches the consumer. **SMELTS, TO DRAW**—They should never be opened, but drawn by the gills and the roe left inside. The heads are left on for most of the styles of cooking. The simplest treatment is the best when the fish are fresh, and they should be merely rolled in flour and fried quickly in a kettle of hot fat. **SMELTS A LA BROCHETTE**—Floured, run upon a skewer side by side, head to tail alternately, dropped into hot lard and fried; served on the skewers if silver or plated, otherwise slipped off the skewer on to a hot dish; garnished with parsley and lemons. **EPERLANS A LA JUIVE**—Smelts in Jewish style; egged, breaded, fried in oil; served without sauce. **EPERLANS A**

## SNA

L'ANGLAISE—Smelts fried and served with anchovy sauce. EPERLANS EN RAGOUT—Smelts stewed in white stock with herbs and wine. EPERLANS AU GRATIN—Seasoned with dried herbs and dipped in butter, covered with bread-crumbs, sprinkled with wine and melted butter, and baked brown. BUIS-SON D'EPERLANS—The fish trussed in ring-form, with their tails in their mouths, and fried; built up in the dish, garnished with fried parsley; butter sauce served aside. Smelts are also broiled, plainly, and either broiled or fried are served with tomato sauce or tartar sauce, and also as a garnish with larger fish. BOILED SMELTS—Clean, scale, wash, and dry the smelts; boil them in equal quantities of white wine and water, 2 tablespoonfuls of olive-oil, and season with salt, pepper, and  $\frac{1}{2}$  lemon peeled and sliced; when done, dish up covered with the following sauce: Take 2 tumblerfuls of white wine, a lump of butter mixed with a little flour, salt, pepper, the juice of 1 lemon, 1 head of garlic blanched and pounded, and chopped parsley and chives; warm in a saucepan and pour over the fish. STEWED SMELTS—Place in a china fire-proof dish, pour over them a sauce made with fish or veal stock, chopped onions, capers, and fine herbs, and a little chablis wine; let them cook in the oven till tender, and serve in the same dish. Always cut off the head for this mode of dressing smelts.

SNAILS—The "poor man's oyster" is so appreciated by the French that Paris alone consumes some forty-nine tons daily, the best kind coming from Grenoble or Burgundy. The finest specimens are carefully reared in an *escargotiere*, or snail-park, such as the poor Capuchin monks planned in bygone days at Colmar and Weinbach, when they had no money to buy food, and so cultivated snails. But the majority are collected by the vine-dressers in the evening from stone heaps, where the snails have assembled to enjoy the dew. The creatures are then starved in a dark cellar for two months, and when they have closed up the aperture of their shells, are ready for cooking. According to the true Burgundy method, they are boiled in five or six waters, extracted from the shell, dressed with fresh butter and garlic, then replaced in the shell, covered with parsley and bread-crumbs, and finally simmered in white wine. "Snail farms" have been introduced in Switzerland, where many gardens round Davos and Landquart, in the Grisons, are used for the sole cultivation of that Continental delicacy, *escargots de Bourgogne*. A recent authority states that enormous quantities of snails are forwarded annually from Marseilles and Genoa to Paris, and that tens of thousands find their way to the markets of Bordeaux, Lyons, Vienna, and Munich. Such is the demand, that many persons now "cultivate" snails for the markets, and find the business a remunerative one. As many as twenty or thirty thousands can be bred in a very small space. A damp and shady nook is selected for the "park," and the prisoners are kept within bounds by the simple contrivance of sawdust and

## SNA

brambles. This does very well in dry weather, but when it rains, the farmer's wife and children must be constantly on the alert to turn back the run-aways. The Viennese are the greatest snail-eaters in the world. The town of Ulm, on the Danube, is the principal place where snails are fattened for the market, and those which are picked from the strawberry-beds command the highest prices. Importation of snails for American consumption is said to be steadily increasing every year. Snails are obtainable at certain stores and in the French markets of New Orleans all times during the winter. The snails have sealed themselves up in their shells for their winter hybernation, and are exposed for sale in baskets, as dry as beans. ESCARGOTS A LA BOURGIGNONNE—Suppose they are to be cooked *a la Bourgignonne*, the shells are carefully washed and laid on one side; parsley, garlic, chives or *echalotte*, mushroom and butter, are then chopped together into a paste, a little of this is put into the empty shell, and the snail after being washed is restored to its dwelling, and the opening is finally filled up with paste; they are then baked in a dish of white wine for half an hour, with fire above and below them. From this description it will be rightly inferred, that to cook snails *a la Bourgignonne* is no simple matter. SYRUP OF SNAILS—A certain cordial made with snail-meat (*sirop d'escargots*) is recommended by medical authorities as an alleviative of pulmonary affections; and SNAIL SOUP (*bouillon d'escargots*) is a preparation which possesses very strengthening properties. SNAILS RAW ON THE SHELL—Sceptics who do not believe in the stomachic value of the snail will hear with no little disgust that they are sometimes eaten alive by persons who profess a great faith in their curative virtues. They first break the shell to extricate the inmate, which is then well washed and swallowed like an oyster. I have never tasted raw snails, and have no special desire to do so, but I have been assured by those who have had the courage to try the experiment that the gastronomic sensation is a most agreeable one. SNAILS FOR THE RESTAURANTS—The mode of preparing the snails for consumption is very simple, but requires a deal of care and cleanliness. The first thing to do is to scrape off the clay that covers the aperture, then the shells are placed in large vessels containing water, salted and acidulated with vinegar. The object of this is to cause the animal to throw off the slime and impurity with which it is impregnated. After half an hour's soaking the snails are washed in cold water, placed in large wicker-baskets, and plunged into immense coppers containing boiling water, where they are allowed to simmer for five minutes. Next, with the aid of a small two-pronged fork, the snails are removed one by one from their shells, thrown into boiling water slightly salted, garnished with vegetables and allowed to cook for three-quarters of an hour. The cleaning of the empty shells is an important point. After being well scrubbed and

## SNA

washed, they are put to boil for two hours in plenty of water containing soda in the proportion of one ounce for every hundred shells. Finally they are washed again, drained and dried in hot closets. The next process is the refilling of the shells. **SNAIL MEAT**—"People who have tasted periwinkles may easily form an idea as to the nature of the contents of a snail-shell. The substance of one resembles the substance of the other, but the taste differs essentially. There is a pleasing and distinctive flavor belonging to the inmate of the tiny sea-shell, whilst the meat of the *escargot* is entirely tasteless, and would not be so esteemed were it not for the piquant stuffing associated with it. For my own part I can not avow that I am an enthusiastic admirer of *escargots*, however dressed and served. I certainly eat them without disgust, but also without any particular satisfaction."

**SNAPDRAGON**—A Christmas game for a family; raisins in a warm dish are covered with brandy or any spirit that is strong enough to burn; it is set on fire in a darkened room, and the sport consists of picking the raisins out of the fire with the fingers.

**SNIPES**—Well-known and fairly abundant small game birds; there are three or four varieties; superior to the woodcock. The English and French epicures say snipes must not be drawn, but the intestine and all eaten; fastidious Americans do not agree to this, and the cooks have to make the styles of cooking to suit. **BROILED SNIPES**—Are split down the back, the insides removed, wiped, flat-

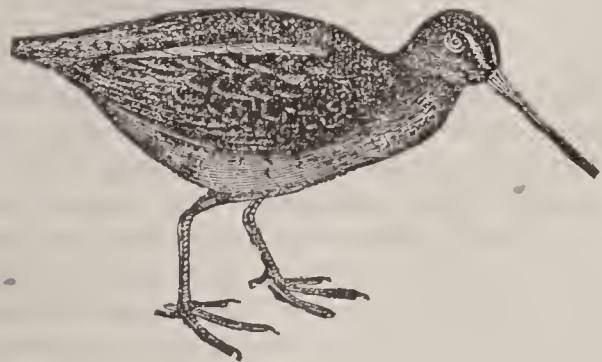

SNIPE—BECASSINE.

tened, broiled and served on toast the same as quails. **BECASSINES A LA BROCHIE**—Snipes roasted on a spit or long skewer. They are plucked, the heads skinned, the gizzards taken out, intestine (trail) left in; the head being bent over the long bill is thrust through the flesh of the legs, each bird has a slice of fat bacon on the breast; they are run upon a spit side by side and roasted rare, served on toast with their own drippings and *maitre d'hotel* butter. **BECASSINES EN CROUSTADES**—Shallow cup shapes of fried bread, the insides spread with liver forcemeat, a roasted snipe in each croustade, baked a few minutes just before serving. **BECASSINES A LA BONNE BOUCHE**—Snipes filled with a forcemeat of liver pounded with bacon, covered also with forcemeat and baked; served on shapes of fried bread, with truffle sauce. **SNIPE PUDDING**—Is a thoroughly English dish almost unknown to French epicures.

## SOL

It is, nevertheless, a delicious entrée. The snipes are split in halves and seasoned; a brown jam sauce is made with fried onions, mushrooms, flour, wine, and the trails of the birds, strained, poured over the snipes in a deep dish lined with short paste, a paste lid put on, steamed two hours; served hot. **BECASSINES EN TERRINE A L'IRLANDAISE**—A cold dish. Snipes cut in halves baked on layers of bacon with butter, with a temporary flour-and-water paste cover over, which is removed when the baking is completed. **BOUDIN DE BECASSINES A L'ÉPICURIENNE**—French name of the snipe pudding above. (*See Woodcock.*)

**SNOW CAKE**—The whitest white cake (except angel cake) made with a large proportion of corn starch, some flour, white of eggs, white butter, sugar and lemon juice.

**SNOW PUDDING**—Cold trifle. One of several domestic names applied to Russian jelly. It is clear, uncolored gelatine jelly, whipped while setting on ice and whipped white of eggs added at the same time, making a snow-white spongy jelly when finally set. Served with cold yellow custard as sauce. Also called lemon sponge, lemon snow, floating island, etc. (*See Muscovite.*)

**SOAP—SOFT SOAP**—To one pound of potash, add three gallons of water. Boil the potash until it is all dissolved. Then add three pounds of any kind of soap-grease - the cleaner the better—to the lye, and set it to boiling. It usually becomes soap after boiling from one to five hours. Then add nine gallons of water, and stir well together. When cool it will be beautiful white soap, if the grease was clean. **HARD SOAP**—Take one pound of potash, dissolve in twelve quarts water in a kettle calculated to make the soap, add to the lye five pounds of grease and boil slowly, add water to the kettle as it boils down. Keep about the same quantity in the kettle until it becomes soap. Then add eight ounces common salt, and boil ten minutes, which will separate the water from the soap. If rosin is wanted, melt that in a separate kettle. Add lye with it until it becomes thick, which will take about one quart to a pound of rosin. Then add the rosin to the boiling soap before the salt is added. The salt causes the soap to separate from the water and rise upon the top. When cold it can be taken off or dipped into moulds while hot. The above hard soap may be perfumed just before it is cool. When lye is too strong it will not make soap; therefore, if the kettle, while boiling, is not kept about the same quantity, the lye will boil down too strong.

**SOCLE**—A pedestal, stand, base for an ornamental piece of cooks' work. **SUR SUCLE**—On an ornamental stand.

**SODA SYRUPS**—See *Syrups*.

**SOLE**—No other fish is named so frequently in English and French menus as the sole and, as a consequence, it is named with great frequency in menus of this side as well, yet there are no soles

## SOL

in American waters, and all that are genuine are the few brought over in ice by the steamers. The flounder and the Nova Scotia fluke have to do duty for the sole on this side in a general way, and other fish are pressed in to furnish the coveted fillets when those are not available. A tourist in California wrote back complaining that all the fillets of soles in San Francisco were cut from halibut. On the other hand we have some of the choicest fish that swim which are quite unknown in European markets, and they scarcely find a place in our own bills of fare for the odd reason that the majority of the cooks were brought up from childhood on sole, and have not yet learned pompano, or Spanish mackerel, or anything but the flounder substitute. The sole is a flatfish of excellent quality, best adapted to be cut



CANDY SULTANE SUR SOCLE.

in thin fillets (boneless bands or strips), and coiled, and cooked in that neat shape. FILET DE SOLE A LA MARGUERY—"As Villemessant, the founder of the *Figaro*, used to say, one can always tell if a man is a *gourmet* by listening to what he orders in each particular restaurant, for every restaurant here has its special dish, on the preparation of which, to a certain degree, its reputation depends. The *Restaurant du Gymnase*, or *Cafe Marguery*, for instance, is celebrated for its *filet de sole a la Marguery*, the fish being prepared with a delicious sauce made of mussels, shrimps, and white wine. The recipe for the famous *sole Marguery* appears to be much the same as for first-class *sole Normande*. Boil sole in chablis, take out fish and remove bone, dividing meat into four fillets. Add more wine to that in

## SOR

which fish was cooked, and make a ragout of shrimp-meat (from the tails), crawfish-meat (*idem.*), mushrooms, truffles, mussels, butter, and a good piece of meat-stock. When these ingredients are all thoroughly cooked, pour the sauce over the fillets of sole, and stand in the oven for some minutes. Garnish the dish with fried white-bait, and serve. The above recipe was given me by a *cordon bleu* who lives in the house. SOLE A LA NORMANDE—To prepare this dish in perfection, it is imperatively necessary that the fish should be a big one, and that the flesh should be entirely separated from the bones. The oval silver dish, moreover, on which this delicacy is usually served, should be well buttered and cunningly powdered with finely minced and scrupulously blanched onions. Before being cooked, the sole should be seasoned with pepper and salt, and judiciously moistened with white wine; and while the cooking is in process the sauce should be a-making—a "maigre allemande," or white sauce, of which the stock is the water in which mussels have been boiled. The garnishing comprises these same mussels, together with oysters, champignons, fried smelts, and fried sippets of bread. Just for five

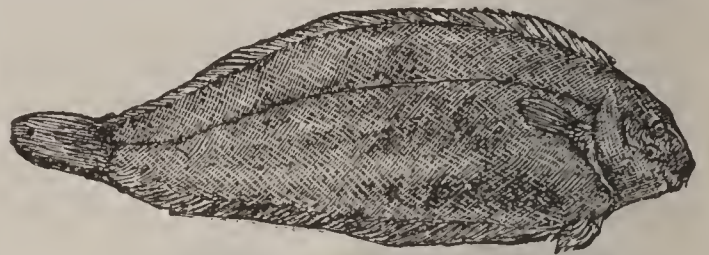

SOLE.

minutes before serving must the sole be popped into a moderately heated oven; but the delicate white of the allemande sauce must not be suffered to brown. In nineteen French restaurants out of twenty there is served with the sole an "allemande grasse"—such a vulgar sauce, indeed, as is poured over a fricassee of fowl or a dish of boiled sheep's trotters; but a real "Normande" should have essence of fish and not meat, for its fundamental motive. FILLETS OF SOLES—Make a nice breakfast dish served with tomato sauce. Dip each fillet in batter, see that they are well covered with this, and fry in boiling fat until they are nicely browned. Serve in the center of a dish, and pour the sauce round. SOLES A LA PARISIENNE—Scrape and clean out your soles, cut off the heads and tails, and toss in a sautépan with sufficient fresh butter to cover them; sprinkle with chopped parsley, chives, salt and pepper; turn the fish, and, when cooked, dish up, covered with Italian sauce. FILLETS OF SOLE A LA JOINVILLE—Toss the fillets in a saucepan with butter. When done, place round a dish, and fill the center with boiled shrimps and minced truffles. Cover with German sauce, to which you have added a little shrimp butter.

SOLE (Fr.)—Sole; same as in English.

SORBET (Fr.)—Frozen punch.

## SOR

SORBETIERE (Fr.)—A freezing box in which sorbets and other ices are congealed.

SORREL—A sort of sour spinach; a weed with acid juices, used as greens in soups, in sauces in the form of a purée, and in combination with spinach. Not the same as the low-growing, clover-leaved, sour weed called sheep-sorrel in the prairie states. Sorrel grows tall amongst the grass. "The sorrel again, whose crimson sepals flaunt themselves amongst our meadow herbage, is largely utilized in the preparation of French salads. Sorrel, prepared for table exactly like spinach, is an excellent accompaniment to sweetbread, fried calves' brains, or any similar dish. Sorrel makes an excellent sauce for veal, pork, or winter geese. It should, like spinach, be put in a sauce-pan without water, except that which hangs to its leaves in washing. It should be boiled slowly, and then be beaten up with cream, butter and the yolks of eggs."

SOUFFLE—A puff; something light. There are soufflés of almost anything eatable. Whatever rises to an unusual degree is a soufflé; the usual means is to mix whipped white of eggs into a pasty preparation, whether of meats or sweets, just before putting it into the oven or steamer. (*See Monte Sano Pudding.*)

SOUPS—SAID ABOUT SOUPS—" 'C'est la soupe,' says one of the best of proverbs, 'qui fait le soldat.' ('It is the soup that makes the soldier.') Excellent as our troops are in the field, there cannot be a more unquestionable fact, than their immense inferiority to the French in the business of cookery. The English soldier lays his piece of ration beef at once on the coals, by which means the one and the better half is lost, and the other burnt to a cinder. Whereas six French troopers fling their messes into one common pot, and extract a delicious soup ten times more nutritious than the simple *roti* can ever be."—"Dumas, the elder, was excessively fond of onion-and-cabbage soup, which he made himself. Soup contains the greatest amount of nourishment that can be taken with the least exertion."—"Scotch broth is to Scotland what *pot-au-feu* is to France, made with mutton instead of beef, and involves an important question in household economy."—A writer of New York says: "Nearly every hotel in this city now uses the individual soup tureen, and it is a fact to be recorded with pleasure. The day has happily gone by when plates of cold soup were handed round the table." FOR BISQUE SOUPS—See *Bisque*. FOR CLEAR SOUPS—See *Consommés*. FOR GARBURE SOUPS—See *Garbure*. Various special soups may be found described under the several letters, such as *Turtle*, *Terrapin*, *Conger*, *Chowders*, *Game Soups*, etc., and in national cookery articles.

SOUPS OF BARLEY—SCOTCH BROTH—See *Scottish Cookery*. CREAM OF BARLEY A LA JARDINIERE—Cream-purée of barley tinted with spinach green, with vegetables cut size of macaroni with a column cutter; peas, cauliflower, etc. CREAM OF

## SOU

BARLEY A LA JOINVILLE—Cream-purée tinted pink with crayfish-butter or lobster-coral, with pieces of sweetbreads and crayfish-tails. CREAM OF BARLEY A LA VIENNOISE—White cream of barley with fried *croutons*. POTAGE A LA CREME D'ORGE—Cream of barley.

SOUPS OF BEEF—ALAMODE BEEF SOUP—See *Alamode*. BEEF SOUP A L'ANGLAISE—Smooth brown soup of stock thickened with *roux*, lean beef cut in squares, celery, turnips, carrots likewise. BEEF BROTH WITH RICE—Beef stock highly seasoned, with rice cooked separately and added. OX PALATE SOUP A L'ANGLAISE—Palates peeled, boiled, and pressed, cut in squares, put in clear soup with egg-quenelles and Madeira wine; lemon aside. OX PALATE SOUP THICK—Brown like beef-soup; pressed palates cut in dice; lemon slices, sherry, parsley. OX CHEEK SOUP A LA NELSON—Stock made of ox-checks, beef, ham, vegetables; thick, brown, with wine, and the meat cut in squares. OX TAIL SOUP—Is made either clear or thick; tails in round slices stewed 2 or 3 hours; beef stock; carrots and turnips in slices like the tails; all served in the soup; little sherry and lemon. OX TAIL SOUP A L'ARNOLD—The preceding thick, brown, with barley. POTAGE AUX QUEUES DE BŒUF—Ox-tail soup.

SOUPS OF CABBAGE—CABBAGE SOUP A LA CHAMBERY—Savoy cabbage sliced and half-fried; boiled in salt-pork stock; fried forcemeat-balls of beef served in it. PUREE OF CABBAGE A LA PIEMONTAISE—Cabbage passed through a sieve, with broth thickened, cream, *croutons*. CABBAGE SOUP A LA LANGUEDOCIENNE—Raviolis made of fried cabbage and onion, in potato soup with cheese, yolks, etc. CABBAGE SOUP A LA RENTIERE—Stock with salt pork, cabbage, sausages, vegetables, sippets of bread; all served in the soup. CABBAGE SOUP A LA ROUENNAISE—Sliced cabbage half-fried, stewed in stock, with sippets of bread. CABBAGE SOUP WITH PORK—Assorted vegetables, potatoes, cabbage, pork; all stewed together in stock. CABBAGE SOUP WITH RICE—Sliced and fried cabbage and onion in salt-pork stock with rice. GREEN CABBAGE AND POTATO SOUP—Stewed summer-cabbage and potatoes together in stock.

SOUPS OF CHICKEN—CHICKEN A LA CHIFFONADE—Seasoned clear chicken broth, pieces of chicken in it previously half-fried; shred lettuce, sorrel, chervil added. CHICKEN A LA KITCHENER—Broth, thickened white *roux*; roast chickens, selected meat saved, skin and trimmings boiled in broth. CHICKEN A LA KETTNER—Roast chickens cut up, skin and trimmings in broth, thickened white *roux*, chicken meat, rice, and cream.—CHICKEN A LA MALMAISON—White soup containing two colors of chicken quenelles, yellow and green, with small carrots, cauliflower, yolks, cream. CHICKEN A LA MESSINOISE—White purée of chicken and almonds with quenelles of chicken and tomato. CHICKEN A LA PRINCESSE—Cream-

## SOU

colored, thick, with stuffed braised lettuce aside.—**CHICKEN A LA SONTAG**—Pieces of chicken half-fried with ham in butter, along with leeks and rice in thickened broth. **CHICKEN A LA ST. GEORGE**—Cream-colored with barley, chicken meat and fried forcemeat balls. **CHICKEN A L'ANGLAISE**—Seasoned chicken stock thickened, with pieces of chicken. **CHICKEN WITH OKRA**—Pieces chicken half-fried with onions, stock, tomatoes, okra, rice. **CHICKEN WITH RICE**—Pieces chicken half-fried, in stock with rice, plain. **CHICKEN WITH TOMATO**—Pieces fried with ham and onions, stock, tomato purée. **CHICKEN BROTH A LA BRITANNIA**—Printanier vegetables and "royal" chicken custards in broth. **CHICKEN A LA CHEVALIERE**—A garbure of cream-soaked and fried rolls served aside with broth. **CHICKEN A LA CHORSEUIL**—Chicken stocks with "royal" chicken custards and asparagus tops. **CHICKEN A LA NICOISE**—Assorted vegetables including cabbage cut in dice, rice and chicken meat in broth. **CHICKEN A LA PALESTINE**—With Jerusalem artichokes cut small and chicken. **CHICKEN A LA VIENNOISE**—Consommé with barley, chicken meat, chervil. **CHICKEN WITH POACHED EGGS**—Broth with asparagus tops and poached egg in each plate. **PUREE DE VOLAILLE A LA BEARNAISE**—Purée of chicken and almonds, boiling cream, squares of chicken meat, fried rings of bread. **PUREE DE VOLAILLE A LA JUSSIENNE**—Purée of chicken and bread panada in thickened broth with yolks and fried crusts. **PUREE DE VOLAILLE A LA MILESIENNE**—Tinted green; purée of chicken with pounded pistachios. **PUREE DE VOLAILLE A LA PERIGORD**—Purée of chicken, rice and almonds, with "royal" custards containing purée of truffles. **PUREE DE VOLAILLE A LA REINE**—Pounded chicken and rice in stock passed through a sieve, cream, butter, croutons. **PUREE DE VOLAILLE A LA ST. MANDE**—Cream-colored with chicken purée, pieces of cooked cucumbers, rice, chervil. **PUREE DE VOLAILLE A LA CREME**—White cream purée with white meat of chicken.

**SOUPS, GIBLET**—They are either clear or thick. The fleshy part of the gizzards of fowls cut from the gristle; the giblets are fried first, then stewed, and soups varied like beef and ox-tail soups. **POTAGE AUX ABATIS D'OIE**—Giblet soup, goose.

**SOUPS FARINACEOUS**—**TAPIOCA SOUP A LA MONTGLAS**—Thin tomato soup with tapioca, macaroni cut short, breast of chicken and red tongue in shreds. **TAPIOCA AU CONSOMME**—Clear soup with tapioca. **TAPIOCA AND TOMATO**—Thin tomato soup with tapioca. **TAPIOCA WITH RICE**—Clear soup with tapioca and rice. **SAGO SOUPS**—Same variations as tapioca. **POTAGE AU SAGOU**—Sago soup. **POTAGE A LA JENNY LIND**—Sago cream soup, yellow with thickening of yolks. **POTAGE A LA RECAMIER**—Wash  $\frac{1}{4}$  lb. best pearl sago thoroughly, then stew it quite tender and very thick in water or broth (it will require nearly a quart of liquid, which should be poured on to it cold and very gradually heated), then mix with a pint of boiling cream or

## SOU

milk, and the yolks of four eggs, and mingle the whole carefully with two quarts of strong veal or beef stock, which should be kept always boiling. Serve immediately. **CREAM OF SEMOLINA**—Farina cream soup finished with yolks, cream, butter, and light croutons. **POTAGE SEMOLINA A LA PIEMONTAISE**—Game broth with farina and quenelles of farina, butter and cheese. **POTAGE SEMOLINA A LA VENITIENNE**—Farina cream soup light yellow with yolks, wine, lemon juice, Parmesan cheese and fillets of partridges. **POTAGE BARAQUINE**—White tapioca soup with strips of chicken and truffles. **POTAGE A LA GOUFFE**—Brown tapioca soup with squares of chicken breast, tongue and truffles. **POTAGE A LA CREME DE TAPIOCA**—Tapioca cream soup.

**SOUPS OF FISH**—**FISH SOUP A LA BRABANCONNE**—Strong fish stock with Rhine wine and tomato purée added; "royal" custards and collops of fish. **FISH SOUP A LA BATELIERE**—Thickened fish stock with sherry, oysters, scallops, lobster meat, fish quenelles, fried crusts. **FISH SOUP A LA DUCCLAIR**—Clarified fish broth with white fillets of fish and sippets of dried bread. **FISH SOUP A LA RUSSE**—Clarified fish broth, shredded vegetables, fillets of fish, fried crusts. **POTAGE A LA BAGRATION**—Thickened broth of vegetables and fish, yolks, cream, lemon juice, fish quenelles, oysters, lobster meat, duchesse crusts. **POTAGE A LA CHANOINESSE**—Pink-colored, with crayfish butter, soft roes of fish, mushrooms, oysters, crayfish tails. **STURGEON SOUP A LA SUEDOISE**—Strong fish stock with white wine, brown roux, stewed slices of sturgeon and mussels. **PIKE SOUP A LA CHAMPLAIN**—Fish made into forcemeat balls, fried. Fish stock cream-colored, with Catawba, mussel liquor, the forcemeat balls, fried bread. **PICKEREL SOUP A LA MALMESBURY**—Fillets in small squares cooked in butter and wine. Stock thickened, cream-colored, with mussels, lobster meat and the fillets. **FLOUNDER SOUP**—Thickened fish stock with roux, Catawba, scollops, oysters, and fillets of flounder cut to size of oysters; croutons. **EEL SOUP AMERICAN STYLE**—Pieces of eels half-fried in butter, flour, fish stock, tomatoes, Catawba, croutons. **EEL SOUP A LA HARTFORD**—Cream-colored fricassee of eels with scollops and croutons. **EEL SOUP A LA ST. LAWRENCE**—Pieces of eels simmered in butter and wine. Fish stock with lobster, fried vegetables and aromatics, thickened, creamy. Parsley, lobster meat, eels added. **POTAGE A L'ANGUILLE**—Eel soup. **POTAGE A LA PROVENCALE**—*Bouillabaisse*. **POTAGE A LA POISSONIERE**—White soup with pieces of salmon and sole, oysters and mussels. **POTAGE AUX FILETS DE SOLES**—Fish broth thickened, wine, yolks, and fillets of soles. **POTAGE AUX HUITRES**—Oyster soup. **POTAGE DE HOMARD**—Lobster soup. **POTAGE A LA BISQUE D'ECRIVISSES**—Bisque of crayfish.

**SOUPS OF GAME**—See also *Bisques, Hare, Game, Partridge*. **GAME SOUP A LA CORCOISE**—



## SOU

A soup of partridges, rabbit, salt pork, ham, smoked sausages, soup beef, dried mushrooms, lentils, and vegetables. The meats sliced and served in the strained soup. **BISQUE OF GROUSE**—Game broth with several kinds of meat, etc., thickened with bread panada, wine, fillets of grouse in fine shreds "The grouse soup at Hamilton Palace used to be made on the principle of a young grouse to each of the party, in addition to six or seven brace stewed down for stock." **PUREE OF DUCK A LA NORFOLK**—Mallards roasted, then stewed, meat pounded through a sieve; game broth, panada to thicken, port wine, croutons. **DUCK SOUP A LA HONGROISE**—Game soup containing purée of vegetables and ham, with barley and the ducks in pieces. **RABBIT SOUP A LA POLONAISE**—Light color. Rabbit stock with ham and vegetables thickened with roux and yolks; wine, fillets of rabbits; rice aside. **HARE SOUP**—See *Hare*. **PUREE DE GIBIER**—Purée of game. **PUREE DE LAPEREUX**—Purée of rabbit. **PUREE DE GROUSES**—Purée of grouse. **POTAGE AUX GROUSES**—Grouse soup. **POTAGE AUX FAISANS**—Pheasant soup. **POTAGE AUX PERDREAUX**—Partridge soup. **POTAGE A LA LIEVRE**—Hare soup. **POTAGE A LA VENAISON**—Venison soup. **POTAGE A LA CHASSEUR**—Game soup with pieces of the game, onions, potatoes and mushrooms. **PIGEON SOUP A LA FABERT**—Pigeons cut up and fried with ham and butter; flour, broth, sherry, julienne, vegetables and the pigeon pieces served in it. **PIGEON SOUP BELGIEN STYLE**—The preceding with carrots and green peas.

**SOUPS OF ITALIAN PASTES**—**MACARONI SOUP**—Boiled macaroni cut short in beef broth. **MACARONI A LA CALABRAISE**—A dish of macaroni and cheese, brown tomato sauce, garlic, butter, etc., served aside with beef broth. **MACARONI A LA CANINO**—Dish of macaroni and cheese, purée of fowl and gravy in alternate layers served aside with broth. **MACARONI A LA TOSCANE**—Dish of macaroni and cheese, tomatoes, sliced mushrooms and fried egg plant, and gravy in alternate layers served aside with broth. **MACARONI A LA VILLAGEOISE**—Broth with inch lengths of macaroni and fried leeks. **MACARONI AND TOMATO**—Inch lengths in tomato soup, cheese aside. **VERMICELLI A LA GRECQUE**—Thickened, cream-colored with yolks, cream, lemon juice, vermicelli. **VERMICELLI A LA NAVARRAISE**—Brown, thickened with tomato purée and vermicelli. **VERMICELLI A LA PLUCHE**—Clear, with shreds of green along with the vermicelli. **VERMICELLI A LA WINDSOR**—Slightly thickened consommé with chicken quenelles and vermicelli. **VERMICELLE AU MAIGRE**—Without meat; vermicelli in salted water, butter, yolks, cream. **VERMICELLE A L'OSEILLE**—Chicken broth, thickened, yolks, cream, stewed sorrel and vermicelli. **VERMICELLE AU TOMATE**—Consommé mingled with tomato purée and vermicelli; grated Parmesan aside. **VERMICELLI PLAIN**—Short cut in beef broth. **LASAGNES SOUP**—Lasagnes paste boiled, cut short in broth, consommé, or in any soup,

## SOU

same as macaroni. **NOUILLES**—In any way same as macaroni, vermicelli and fidelini. **FIDELINI A LA ROYALE**—Thickened stock with yolks, cream, fidelini cut short; grated Parmesan aside. **POTAGE SPAGHETTI A LA SICILIENNE**—A dish of spaghetti in brown tomato sauce with garlic, dried mushrooms, etc., and hot butter served with beef broth aside. **SPAGHETTI A LA TURINOISE**—Consommé mingled with tomato purée and short-cut spaghetti and quenelles; cheese aside. **SPAGHETTI AU PARMESAN**—Spaghetti in clear stock; cheese aside.

**SOUPS OF LAMB AND MUTTON**—**LAMB SOUP A LA PIEMONTAISE**—Pieces of lamb in squares half fried, flour, stock, vegetables, rice. **LAMB SOUP A LA WINCHESTER**—White soup with cream, starch, wine, leeks and meat cut small. **LAMB SOUP A LA REINE**—Cut up roast lamb, vegetables and rice in broth. **LAMB BROTH WITH BARLEY**—Barley, meat in dice and vegetables. **MUTTON SOUP A LA COWLEY**—Brown mutton broth with barley and boiled mutton chop in each plate. **MUTTON SOUP WITH BARLEY**—Strong mutton broth with barley and meat in squares; green herbs. **MUTTON SOUP A LA ROUENNAISE**—Purée of barley with cream, and mutton cut in squares. **MUTTON SOUP A LA VIENNOISE**—Force-meat balls of mutton and parsley fried, in barley broth. **POTAGE AU MUTTON**—Mutton broth served with the mutton in it. **POTAGE A L'ECOSSAISE**—Scotch mutton broth. **BARLEY BROTH A LA FRANCAISE**—Plain mutton broth with barley and sippets of bread. **SHEEP'S TAIL SOUP A L'ARMENIENNE**—Tails cut in lengths, parboiled, fried with vegetables, curry, flour, stock. Pieces in the soup, rice aside. **POTAGE AUX QUEUES D'AGNEAU**—Lamb's tail soup.

**SOUPS OF ONIONS**—**ONION SOUP A LA PLESSEY**—Onions half fried, in slightly thickened chicken stock, with sippets of bread. **ONION SOUP WITH CHEESE**—Onion soup thick poured on bread spread with cheese. **ONION SOUP WITH EGGS**—Onion soup yellow with yolks and milk. **SOUP OF SMALL ONIONS A LA CHEVREUSE**—Very small onions and peas in chicken broth. **PUREE OF ONIONS A LA BRETONNE**—Brown soup with purée of onions and fried crusts. **PUREE OF ONIONS A LA DIEPPOISE**—A fish and onion soup, white, with fish quenelles. **PUREE OF ONIONS A LA NANTAISE**—Brown veal stock with purée of fried onions; *croutons*. **PUREE OF ONIONS A LA NASSAU**—White cream of Bermuda onions; butter, sugar, thickened broth, cream, *croutons*.

**SOUPS OF PEAS AND BEANS**—**GREEN PEA SOUP A LA DUCHESSE**—Dry green peas boiled with ham and herbs, rubbed through a sieve; the liquor added, and *croutons*. **GREEN PEA SOUP A LA MARLY**—Green peas in chicken broth, with shreds of lettuce and chervil. **GREEN PEA A LA PRINTANIERE**—Purée of peas with asparagus tops, string beans cut small, green herbs, sugar, butter, etc. **GREEN PEA A LA ST. CLOUD**—Green peas boiled with salt pork

## SOU

and herbs in veal stock, skimmed; fried crusts. **GREEN PEA A LA ST. GERMAIN**—Green purée of peas with "royal" custards composed of purée and eggs cooked in small moulds. **GREEN PEA SOUP WITH RICE**—Purée soup with boiled rice. **PEA SOUP A LA NAPIER**—Peas boiled with salt pork, passed through a seive, the pork cut in dice and fried, served in the soup with cut mint. **PEA SOUP A LA VILLAGEOISE**—Peas and shred vegetables in beef stock, with sippets of bread. **PEA AND BRUNOISE SOUP**—Brunoise with purée of peas and sippets of bread. **PEA AND JULIENNE SOUP**—Purée of peas with julienne vegetables. **SPLIT-PEA SOUP**—Split-peas boiled with salt pork, passed through a seive, in stock slightly thickened; fried *croutons*. **PUREE OF LENTILS**—Lentils boiled with salt pork, and same as peas and beans. **PUREE OF STRING-BEANS**—Green soup; beans cooked in salted water, passed through seive, in stock thickened with *roux*, sugar, butter, boiling cream, coloring, *croutons*. **PUREE OF STRING-BEANS A LA SAVART**—Whole peas and short-cut string-beans added to the preceding. **BEAN SOUP**—White navy beans boiled, passed through seive, in slightly thickened stock of salt pork, etc.; milk or cream; *croutons*. **PUREE OF LIMA BEANS**—Beans and various vegetables boiled and purée together; white stock; *croutons*. **PUREE OF FRESH BEANS**—Green shelled beans boiled with salt pork and onions, beans and onions through a seive, together, in thickened broth; *croutons*.

**SOUPS OF POTATOES**—**PUREE OF POTATOES A LA FAUBONNE**—Potatoes cooked with ham, pounded through a seive in beef stock with yolks, butter, and julienne vegetables. **PUREE A LA JACKSON**—Purée with boiling cream, little sugar, butter, *croutons*. **PUREE A LA PARMENTIER**—Cream of potatoes with chervil and sorrel. "The *potage Parmentier* is prepared as follows: Peel a dozen potatoes, slice and put them in cold water. Slice two onions, a head of celery, and the white part of two leeks. Put these ingredients in a stewpan with four ounces of butter and the sliced potatoes. Fry the whole for ten minutes, and then moisten with two quarts of white broth. Add three cloves, some salt, a bunch of parsley, and let simmer until the vegetables are done; then rub through a fine seive or tammy. Return the purée into a stewpan; set it on the fire to boil slowly, adding a little broth if the soup is found too thick. Let it simmer for twenty minutes, taking off the scum as it rises. When ready to serve, add a liaison of four yolks of eggs, diluted with half a pint of cream, and four ounces of butter, divided into small pieces. Throw in the soup a little finely-chopped and blanched chervil, and send to table separately some small fried *croutons*." **PUREE OF POTATOES A LA TURENNE**—Potatoes baked and mashed, milk, broth, fried salt-pork squares and fried sorrel. "GOOD WOMAN'S SOUP"—Now a first-class recipe for that eminently French soup, *a la bonne femme*: **Purée Pomme a la Bonne Femme**—Peel two quarts of potatoes, mince, and boil in a sufficiency of good

## SOU

bouillon; pass the purée through a tammy, and pour it into a saucepan, where allow it to boil; add some blanched lettuces and a handful of minced sorrel, allowing the boiling to continue until the lettuces are cooked. Prepare a garnish of vegetables—*asparagus-tops*, cauliflowers, green peas, a handful of Brussels sprouts cooked in salt and water, strained after cooking, and mixed with butter. At moment of serving add the vegetables to the purée, and bind with five yolks mixed with a pint of sweet cream and a pinch of nutmeg. Do not allow the soup to boil after adding the cream." **POTATO SOUP WITH LEEKS**—Fried leeks in shreds stewed with cut potatoes in stock; sippets of bread.

**SOUPS OF RICE**—**RIZ A LA FLAMANDE**—Thickened stock with rice and assorted vegetables, including Brussels sprouts or cabbage cut small. **RIZ A L'INDIENNE**—Curry soup with rice and pieces of chicken. **RIZ A LA MAINTENON**—Cream-colored with yolks and cream, and sliced breast of chicken. **RIZ A LA PAYSANNE**—Vegetable soup with rice. **RIZ A LA SULTANE**—Stock of mutton, chicken, ham and vegetables strained; colored with saffron, yolks, cream; chicken meat and sultana raisins. **RIZ A LA TURQUE**—Little timbales of buttered rice, yellow with saffron, served aside with beef broth. **RIZ AUX POINTES**—Clear soup with rice and asparagus tops. **RIZ AU KARI**—Yellow, slightly thickened, curry and *roux*, cooked rice added. **RIZ AU JULIENNE**—Julienne soup with rice. **RIZ AU TAPIOCA**—Cooked rice added to tapioca clear soup. **RIZ AU TOMATE**—Consommé, tomato purée and rice mixed. **RISOTTO A LA PIEMONTAISE**—See *Italian*. **CREAM OF RICE A LA BUFFON**—Purée of rice with cream, chicken broth, etc., and small quenelles and asparagus tops. **CREAM OF RICE A LA CAVOUR**—Cream purée with short macaroni and "royal" custards made with almond milk. **CREAM OF RICE A LA MEDICIS**—Very small fried rice croquettes and grated Parmesan in cream of rice. **CREAM OF RICE A LA PRINCESSE**—Cream purée with asparagus tops. **CREAM OF RICE A LA ST. SEVER**—With lozenge shapes of bread fried in butter. **RICE PILAF**—See *Oriental Cookery*.

**SOUPS OF SHELL-FISH**—**SOFT CLAM SOUP**—Clams opened and hard part removed, boiled two minutes in broth, add boiling milk and white sauce or thickening, butter, mace, salt, pepper, crackers. **CLAM SOUP, AMERICAN STYLE**—Same as oyster soups; in milk with butter and white sauce or thickening, parsley, crackers. **CLAM CHOWDER**—See *Chowder*. **OYSTER SOUP, WHITE**—Milk, white sauce or thickening, oyster liquor, oysters soft cooked, butter, crackers, seasonings. "Put 4 doz. oysters with their liquor into a stewpan, and when upon the point of boiling drain them upon a seive, catching the liquor in a basin. Put the oysters into a soup tureen, taking off the beards to throw into the liquor, and then melt  $\frac{1}{4}$  lb. butter in another stewpan on the fire, to which add 4 oz. flour; stir

## SOU

slowly, keeping it quite white, over a slow fire; let it become cool, then add the liquor with the beards, 2 qts. stock and 1 qt. milk. Season with salt, cayenne, 5 peppercorns, half a blade of mace, 1 dessertspoonful of anchovy and 1 tablespoonful of Harvey sauce, stirring till boiling. Boil quickly at the last, then skim well, add 1 gill of cream, strain through a sieve over the oysters, and serve." OYSTERS AUX FINES HERBES—Fish broth and oyster liquor thickened, half-fried shallots, mushrooms, parsley and oysters in it, and white wine; no milk. OYSTER SOUP WITH OKRA—Fried onions and ham, in butter, tomatoes, oyster liquor, green pepper, okra in thin slices, oysters added last; an oyster gumbo. CRAYFISH SOUPS—See *Bisques*. MUSSEL SOUP—See *Mussels*. LOBSTER SOUP A L'INDIENNE—A lobster curry soup; salt pork, ham and vegetables fried; curry, flour and stock added; lobsters boiled and pounded (shells and all) with yolks and cream, and strained through a sieve; lobster meat and rice in the soup. LOBSTER SOUP A LA MARINIÈRE—Pink-colored; fish broth thickened, containing lobster butter, lobster meat, clams, small onions, sherry. PUREE OF LOBSTER WITH RICE—See *Bisques*.

SOUPS OF TURNIPS—TURNIP PUREE SOUP—Use young white garden turnips. Peel, boil two minutes, then pour off the water; slice the turnips and allow 1 lb. of the vegetables to a pint of separated milk; 12 whole white peppercorns, one blade of mace. Stew till the turnips are tender, then purée through a steel wire sieve; add also a couple of bottled or canned button mushrooms,  $\frac{1}{4}$  oz. of powdered sugar, and salt to taste. Put the purée into a large stewpan, add good white stock to make it of a proper consistence; stir over the fire till it is quite thick and hot, beat in  $\frac{1}{2}$  oz. of butter to the pint of soup, or add cream to give it a soft, mellow taste; pour into a hot tureen, and serve. PUREE OF TURNIPS AND RICE—The two pounded and strained together in veal stock and milk, butter, *croutons*. PUREE OF TURNIPS A LA SAVOISIENNE—Turnips fried first, flour, stock, tomatoes; through a sieve; served with grisini bread. PUREE OF TURNIPS WITH SAGO, rice or tapioca can be varied at will. PUREE OF TURNIPS A LA FRENEUSE—A cream of turnips with balls of turnips scooped out, and sippets of bread. CREAM OF TURNIPS A LA CONDE—Is a purée of beans with turnip purée made into "royal" custards cut in squares in it instead of *croutons*.

SOUPS OF VEAL—VEAL SOUP A L'INDIENNE—A veal curry or mulligatawny, pieces of meat in the soup, and rice. VEAL SOUP A LA POISSY—White, creamy thickened veal stock with vermicelli. VEAL SOUP WITH BARLEY—Plain veal broth with barley. VEAL AND RICE A L'ANGLAISE—Veal broth with gelatinous parts of veal sliced in it and rice. VEAL AND TOMATO WITH RICE—Fried pieces of veal and onion in butter, stock, tomatoes, etc., and rice. VEAL SOUP A LA DAUPHINE—"Royal" custards cut round in veal broth with asparagus tops and

## SOU

tarragon leaves sliced. VEAL BROTH WITH CELERY—Cooked white celery in inch lengths in the broth. VEAL SOUP WITH SORREL—Cream broth with purée of sorrel and sippets of bread.

SOUPS OF CALF'S HEAD—CALF'S HEAD SOUP A LA DUCHESSE—White soup with calfs' head cut in squares, pieces of macaroni and small quenelles. CALF'S HEAD SOUP A LA BRIGHTON—Veal broth with vegetables and aromatics, thickened, sherry, head cut in squares, small balls of veal sausage meat, lemon slices. MOCK TURTLE A LA FRANCAISE—The pressed calf's head cut in dice, espagnole, tomato sauce and beef broth mingled, sherry, chopped yolks, parsley, lemon. MOCK TURTLE A L'ANGLAISE—It is made either clear or thick, the stock as for espagnole without tomatoes, calf's head cut in squares, sherry, port, egg quenelles, lemon. CALF'S FOOT SOUP A L'ANGLAISE—Feet boned, pressed, cut in dice when cold. Soup made of the stock of the feet and other meats and vegetables the same as with calf's head; meat squares in the soup, chopped yolks and lemon slices. CALF'S FOOT A LA DUMAS—Aromatic calf's foot and veal stock with marsala, thickened, feet cut in dice, lemon slices aside. CALF'S TAIL SOUP—Light color, thickened, Rhine wine, pieces of tail and parsley. POTAGE TETE DE VEAU—Calf's head soup. POTAGE A LA FAUSSE TORTUE—Mock turtle soup. POTAGE QUEUES DE VEAU—Calf's tail soup. POTAGE AUX PIEDS DE VEAU—Calf's foot soup. POTAGE A LA COMTESSE—Sweetbreads.

SOUPS OF MIXED VEGETABLES—VEGETABLE SOUP A LA BOURGEOISE—Stock with salt pork and cabbage and various vegetables, all sliced and served in the soup with sliced bread. VEGETABLE SOUP A LA HOLLANDAISE—Balls scooped out of several colors of vegetables and peas, beans, cauliflower; cream soup with the cooked vegetables added. VEGETABLE A LA POLONAISE—Polish soup of stock, bacon, fowl, smoked sausage, cabbage, onions; thickened; all sliced in it to serve. POLISH SOUPS—"In the first place there is *Bigos*, dear to the compatriots of Dombrowski as that general's name itself, a kind of stew prepared with pork sausages, sauerkraut, ham and bacon, wrapped tightly in a napkin and boiled for 2 hours. Their favorite soup is called *Barszoz*, which I have often eaten at Boncrelle's establishment in the Avenue de Cracovie, at Warsaw, and which I can conscientiously recommend. It is made out of beef-bouillon, in which slices of red beetroot are boiled. *Kapusniak*, another national soup, is very nasty, but very much liked; it is made of sauerkraut and bacon boiled in beef-soup. *Ucha* is a Russian soup, but, nevertheless, much appreciated in the oppressed country. A fish-soup it is, prepared from sterlets." VEGETABLE A LA FERMIÈRE—Various vegetables sliced, fried, then boiled in stock; sorrel, chervil, bread. CONSOMME JULIENNE—Vegetables shredded very fine, half-fried in butter and sugar; clear consommé added. SOUPE JULIENNE A LA MONTPENSIER—Julienne with "royal" custards.

## SOU

**SOUPE JULIENNE A LA RUSSE**—Made with shreds of beets, kohlrabi, knot-celery, mushrooms, red tongue, ham. **JULIENNE AUX ŒUFS POCHÉ**—A soft poached egg in each plate of soup. **POTAGE BENOY**—Differs from julienne in so far that in the former the vegetables are cut into dice and *fried* before putting into the soup. **CONSOMME BRUNOISE**—All sorts of vegetables cut into small squares, half-fried with sugar and butter, in clear stock with green peas and shreds of green herbs. **BRUNOISE WITH ITALIAN PASTES**—Rice, *croutons*, tapioca, etc., can be varied at will. **POTAGE DIEPPOISE**—A vegetable soup like julienne with potatoes added, and *croutons*. **POTAGE FAUBONNE**—Purée of peas with small white onions, sorrel, and chervil added. **POTAGE NIVERNAISE**—A vegetable-soup; the vegetables scooped like large peas, with small Brussels sprouts and chicken quenelles. **POTAGE SOLFERINO**—A vegetable broth with green peas, new potatoes, string beans, shred green herbs and pieces grisini bread. **BARZCH A LA POLONAISE**—See *Barzez*. Red-beet liquor clear, containing small-cut pieces of beef, duck, sausage, beets. **FLEMISH SOUP**—Like Brunoise, with all sorts of vegetables cut in shapes, and Brussels sprouts and sippets additional. **POTAGE LIVONIEN**—Purée of all sorts of vegetables and rice, with cream and *croutons*. **POTAGE A LA CROISSY**—Purée of white beans and vegetables together; whole green peas added. **CONSOMME PRINTANIERE**—Clear soup with small-cut spring vegetables, string beans, peas, asparagus points. **PRINTANIERE ROYALE**—The same with “royal” custards added. **PRINTANIERE A LA PARISIENNE**—With custards of chicken-purée and eggs. **PRINTANIERE A LA VICTORIA**—With chicken-quenelles reddened with lobster-coral.—**PRINTANIERE AU VERT-PRE**—Meadow-green printanière with purée of spinach and green coloring. **PRINTANIERE WITH QUENELLES**—With yellow quenelles of chicken. **POTAGE COLBERT WITH EGGS**—Printanière with a poached egg in each plate. **PUREE OF SORREL WITH CREAM**—Veal-broth thickened with *roux*, yolks, cream, purée of stewed sorrel mingled with it. **PUREE OF TOMATOES**—Fried vegetables, onions, ham; flour, tomatoes, stock, strained; *croutons*. **LEEK SOUP A LA PICARDE**—Same as potato with leeks. **PUREE OF PUMPKIN**—Stewed pumpkin strained and diluted with milk, butter, seasonings; sippets of bread. **PUREE OF SPINACH**—Spinach simmered tender in butter; flour, broth, boiled milk, strained, made green. **CREAM OF CAULIFLOWER**—Cooked in white broth, rubbed through a seive with cream, butter, flowerets of cauliflower, *croutons*. **PUREE A LA CRECY**—Stewed carrots with vegetables passed through a seive, stock slightly thickened; *croutons*. **CRECY AU SAGOU**—Mince up 2 onions, fry in butter, add 1 qt. of finely minced carrots, season with salt and a pinch of sugar. When they have lost their humidity, wet slightly with bouillon, cook over a moderate fire, wetting from time to time with bouillon. Pass first through seive and then through tammy. Dilute the

## SOU

purée in 2 qts. bouillon, allow it to boil, withdraw pan to side of fire, skim, and season at the last moment. Add  $\frac{1}{4}$  lb. boiled sago, and bind with 4 yolks of eggs and 2 oz. butter. This done, serve. **PUREE OF CARROTS A L'ALLEMANDE**—Pulp of carrots boiled in salt-pork stock, flour, butter, yolks, cream, and *nouilles*. **PUREE OF ASPARAGUS**—Green, with green tops passed through a seive, and coloring; green tops and fried *croutons* in the soup. **CREAM OF ASPARAGUS**—White; whole asparagus in salt-pork stock passed through seive; stock thickened; cream, green asparagus tops, and *croutons*. **GREEN CORN SOUP**—Grated raw corn in stock of chicken and salt pork with a moderate seasoning of onion; milk or cream, and seasoning of chopped parsley. **CANNED-CORN SOUP**—One can sweet corn, 1 quart boiling water, 1 qt. milk, 3 tablespoonfuls butter rolled in 1 tablespoonful flour, 2 eggs, pepper and salt, 1 tablespoonful tomato catsup. Drain the corn and chop it in a chopping-tray, put on in the boiling water and cook steadily 1 hour; rub through a colander, leaving the husks behind, and return with the water in which it has boiled to the fire; season; boil gently 3 minutes, and stir in the butter and flour; have ready the boiling milk, pour it upon the beaten eggs, and these into the soup; simmer 1 minute, stirring all the while; take up, add the catsup, and pour out. **TOMATO CREAM SOUP**—An American specialty. To make it successfully, that is, without having the milk curdle in it, two separate soups should be made: a purée of tomatoes without spices, and a white cream of chicken or veal soup in which a piece of salt pork has been boiled; the latter should be thickened and finished, and the tomato soup then mingled with it and not afterwards boiled. **PUREE OF CHESTNUTS A LA MANCELLE**—Blanched and boiled Italian chestnuts passed through a seive in game broth; little sugar, butter, nutmeg, yolks, *croutons*. **CUCUMBER SOUP**—See *Cucumbers*. **POTAGE CREME DE CHICOREE A LA COLBERT**—White stock and cream, thickened with yolks, with stewed chicory and poached eggs. **POTAGE A LA RUSSE**—Brown soup with vegetables and round balls of sausage-meat. **POTAGE A LA D'ARTOIS**—Purée of green peas. **POTAGE A LA PALESTINE**—Purée of Jerusalem artichokes. **POTAGE A LA STAMBOUL**—Purée of rice and tomatoes. **POTAGE A LA CHANTILLY**—Purée of lentils with cream. **POTAGE A LA SOUBISE**—Purée of onions. **PUREE DE CONCOMBRES**—Purée of cucumbers. **PUREE DE CHOUX-FLEURS**—Purée of cauliflower. **COLD SOUP**—Put a chicken in a stewpan with a bunch of parsley and fennel and a wineglassful of cucumber juice; 3 pts. of broth. Bring the liquid to the boiling point; stew it, and pop the stewpan on the corner of the stove. When your chicken is cooked, drain it, pass the broth through a napkin and carefully clarify it. Simultaneously you have had cooked a garnishing of celery cut in sticks an inch long. Pour this garnishing into your soup-tureen with the clarified consommé, the scolopped breasts of the chicken, and 1

## SOU

tablespoonful of chopped parsley and green fennel. Thoroughly refrigerate before serving; and your *potage* will be none the worse for a few little bits of ice floating in the liquid. (See *Ices, Iced Soups.*)

**SOUP STICKS**—Long and slender crusty rolls are baked in fluted pans, to be eaten with soup. A substitute for grisini bread in hotels where that harder kind of finger-bread would not be generally acceptable: The moulds to bake in should not be wider than one's middle finger; a sheet of Russia iron can be corrugated at the shops to make a dozen of these little troughs in one piece.

**SOUSE**—Pickled meat, such as pigs' feet, in spiced vinegar, which are called in some sections soured pigs'-feet. **SOUSED SALMON**—See *Salmon, pickled.*

**SOUTHDOWN MUTTON**—A fine breed of sheep improved especially for mutton and not for wool in the South Down's grazing region of England furnishes this name for good mutton in the American bill of fare.

**SOY**—A bottled sauce imported from China and India; composition uncertain.

**SPAGHETTI**—Italian paste like macaroni, but not tubular; it is a solid cord. Cooked in all ways the same as macaroni.

**SPANISH COOKERY**—The same names of dishes are found in the Spanish bill of fare as in the Mexican, as might be expected, and it is likely to be the case that the high-class *cuisine* in the City of Mexico and of the same grade in the cities of Spain are essentially one thing; the old country, however, is subjected to the rasping friction and shaking-up of the cosmopolitan crowd of railway travelers and tourists and can scarcely be so conservative of Spanish habits as the Mexican-Spanish cities may be. This is an observant traveler's sketch of "A RAILROAD EATING-HOUSE IN SPAIN—On the railroad at Miranda I for the first time tested Spanish catering at the buffet. It was a wonderful meal—real Spanish cookery, everything done in oil; but it was by no means bad. The wonderful thing about it was the way in which the passengers got through a meal of ten courses in fifteen minutes by the clock. It was one plate down and another up. The waiters actually galloped round the table piling plates full of soup, fish, entrée, joint, fowl, salad, pastry, cheese, and fruit before the astonished passengers. Heavens, how we ate! How we finished one plate and pushed it aside and seized the full one by our side! No changing knives and forks. It was just one wild waltz from dish to dish." Away from the railroads, however, the family resemblance between Mexico and Spain is plainly discernible; in Mexico the cook-stone is a charcoal furnace, the *brasero*, a furnace made of baked earth, and in the old country a traveler remarks: "It is to be noted that in the Spanish kitchen charcoal takes the place of coal or gas as fuel, while earthenware vessels are generally employed instead of metal ones. **ARROZ CON POLLO**—

## SPA

Rice and chicken. This is one of the national dishes of Spain, and may be seen heading as well the Mexican bill of fare on a former page. It will be found to resemble certain other dishes of meat with rice described in Italian and Oriental cookeries. Put 3 tablespoonfuls of oil into a pan, and when hot place therein some small pieces of fowl, which are to be cooked slowly in the oil for half an hour. By this time the pieces should be brown. Meanwhile, in another pan, fry also in oil, onions, garlic, tomatoes, and red pepper, adding this mixture to the fowl, together with 6 or 8 oz. of well-washed rice and 1 pt. of stock. Cover and simmer slowly until the rice has absorbed the liquid and becomes soft. Two other dishes designated as national dishes differ but little from each other; one is **PUCHERO**—A soup made of any or several kinds of meat at once and an assortment of Spanish vegetables; all this strained out and served in one dish while the soup with bread is served in another. Its foundation is as follows: Fry onion and garlic in olive-oil, add any kind of meat (beef, mutton, or fowl, either alone or mixed together), cut into small pieces, and seasoned with salt, plenty of pepper, and a few chillies. Fill up the *puchera* (an earthen pan) with water or stock, a little vinegar; add *garbanzos* (a kind of chick pea), all vegetables in season and at hand, withholding potatoes until half or three-quarters of an hour before the finish of the dish. The ingredients must simmer slowly. **THE OLLA PODRIDA**—Is the national stew rather than a soup. It is composed exclusively of Spanish produce, such as *garbanzos* (chick peas), *chirizos* (Spanish red sausages), long pepper, garlic, tomatoes, and all sorts of roughly-cut vegetables, such as cabbages, endives, carrots, turnips, onions, gourds, and French beans. All these ingredients are put together in a large earthen pot of a peculiar form, with a piece of smoked bacon, a fowl, and a piece of beef. When done, the vegetables are laid at the bottom of a very deep dish, in the center of which is placed the beef, flanked by the bacon and the fowl. The sausages are dished around, and some of the liquor from the pot poured over the whole. In all restaurants, inns, and hotels in Spain there is invariably an *olla podrida* ready to be served at the traveler's request. "'Tis reported of the Marquis Ciapoint Vitello, an Italian, who was one of the best soldiers that nation ever bred, that he had so great a liking to this sort of *olla* when he was in Spain, that he never cared to dine at home, but walking about the streets, if he smelt in any citizen's house this sort of victuals, he went in there, and sat down at his table to dine with him. Before he went out, he ordered his steward to pay the charge of the whole dinner." It is imparted as a secret, however, that this attractiveness was due to the Spanish sausages which makes both of the foregoing preparations distinctive, and not like the ordinary vegetable stews of other nations. **SPANISH SAUSAGES, OR CHORISSAS, OR CHIRIZOS**—Take equal weights of fat and lean pork taken from the prime parts of the

## SPA

animal; mince this finely, and season strongly with garlic and cayenne; pour over it as much dry sherry as will cover it, and let it stand in a cold place for 3 or 4 days till it has absorbed the liquor; put the meat into large skins, and moisten with the liquor that remains; tie the sausages in links, and hang them in a cool, dry place; they will keep for 6 or 8 months; when wanted, drop the sausages into hot water and let them simmer gently until done enough. One habit in cookery the Spaniards have which is like the Italians' and is a reminder of the fry-shops of Rome. All kinds of cold vegetables are used in Spain, dipped in batter and thrown into smoking hot oil. This method of cooking vegetables is exemplified in the truly Spanish dish of fried sweet potatoes. **SPANISH BEEFSTEAK**—An excellent breakfast dish is a beefsteak cooked Spanish fashion. Take a slice of round steak an inch thick, lay it on a pie-dish, add a little water to baste it with, and bake it for 30 minutes; take it out and cover it with a layer of sliced onions, and bake till the onions are tender; cover it with a layer of sliced tomatoes, and bake 20 minutes; sprinkle on 2 tablespoonfuls of grated cheese, and place in the oven long enough to melt the cheese. During the baking it should be basted every 10 minutes. This recipe is from the note-book of a celebrated caterer. **CHANFAINA**—Is one of the oldest and most celebrated national dishes in Spain, and the name is mentioned in many a legend. The recipe is as follows: Boil a pork or mutton liver in salt water, and cut it when done in little square pieces. Take a fine-chopped onion, some green mint, parsley, Spanish pepper, cloves, whole pepper, salt, cinnamon, caraway, saffron and the liver, and stew the whole with good olive oil, once in a while put some of the bouillon, wherein the liver was boiled, into the stew, and when done put some cracker dust or grated crumbs of stale wheatbread over it, and serve it either hot or cold. (*See Godingo.*) **GASPACHO**—Spanish salad. "It has been said, Spain knows of the tomato when cold. Yes, and for a model *gaspacho* you had better go to Malaga or Seville, for the sun is the prime ingredient. Take several fine tomatoes and as many fine ripe red *pimientos dulces*, and when your tomatoes are well drained cut them all into large (not too thin) slices, add a cucumber in transparently shaved pieces, some of the creamy sweet onion (uncooked), and as much garlic as you can bear. To this add salt, pepper (real pepper from the Isles), and oil, with a fair squeeze of lemon (gathered fresh), and you shall then taste of a dish such as the Spanish saying assures you will make you 'indifferent as to whether you live or die.'" **SPANISH SWEETS**—In Spain fruit takes the place of pastry. Sweet dishes or *dulces* are little used in the Peninsula. The Spaniard's favorite sweet is *turon*, an almond cake, very rich, used chiefly at Christmas time, and the following: **VILHARACOS**—Boil 10 lbs. of pumpkin, when thoroughly done pass through a chinese strainer; add 1½ lbs. flour, 10 well beaten eggs, ¼

## SPI

teaspoonful cinnamon, 2 teaspoonfuls orange water, and ¼ lb. granulated sugar; beat the ingredients well together with an egg white, and fry in very hot sweet oil, the same as for rice fritters. When cooked, put in an oval dish and intersperse with layers of granulated sugar and drown with good sherry wine; serve cold for dessert. This is a national dish for Christmas and New Years. **SPANISH FRITTERS**—Cut some slices of bread into any shape you like, pour a very little brandy on each, mix 2 eggs with 2 spoonfuls of flour and a little milk; cover the pieces of bread with this batter, let them rest half an hour, then fry in very hot lard or butter; serve hot, with a little jam of any kind preferred on each fritter. Spanish fritters (Spanish fashion) are made without the addition of brandy. They are made by cutting the crumb of a French roll into lengths about the thickness of a finger, soaked for 2 hours in cream or milk, to which has been added ground cinnamon, grated nutmeg, sugar to taste, and an egg beaten up in it. They are next drained, then fried in hot butter to a nice brown color, and served hot.

**SPARROW**—"The tiny little wren lives 3 years, the thrush 10, the lark 13, the common hen of commerce 10, the boarding house brand 75, the crow 100, and the English sparrow is immortal." **SPARROW PIE**—An enthusiastic epicure says, speaking of sparrows: "No one who has not tasted it can know what a delicious pie the little bird makes—tender, sweet, and resembling the best of reed-birds." **SPARROW AND REED-BIRD**—The manner of preparing the sparrow does not differ from that in the case of the reed-bird, except that the sparrow meat is somewhat tougher, and requires a little more careful cooking. The sparrow, when nicely browned, flavored and mounted on toast, is so deceptive that old sports are frequently unable to discover the fraud. Many of the sparrows are sent through the adjacent country and sold in the restaurants and hotels for fancy prices and at enormous profit. Experienced cooks say they are frequently at a loss to decide whether or not the birds offered for sale by a suspicious dealer are really reed-birds or sparrows. They profess, however, that the flesh of a reed-bird is a little whiter, the veins a little bluer and smaller and the legs better shaped.

**SPARROW-GRASS**—Common vernacular for asparagus.

**SPECK**—Salt pork or unsmoked bacon. This word is found in old English bills of fare of 200 years ago. It is in common use in some parts of the United States as in "cabbage with speck."

**SPICED SALT**—(*r*)—The famous cook, Durand, advocates the use of spiced salt, which he avers, has often stood him in good stead. The following are the exact quantities he gives in his recipe: Take 20 oz. salt, 4 heads of cloves, 2 nutmegs, 6 laurel leaves, a stick of cinnamon, 4 whole black peppers, a drachm of basil leaves, and the same quantity of

## SPI

coriander seeds; pound in a mortar and pass through a tammy; pound any large pieces that remain over, pass through the tammy, and keep in tightly corked bottles. (2)—2 lbs. salt, 1 oz. of powdered sage, 1 oz. long pepper,  $\frac{1}{2}$  oz. of cloves,  $\frac{1}{2}$  oz. mace,  $\frac{1}{4}$  oz. coriander seeds; moisten the salt with two table-spoonfuls of bay rum, dry, and mix with the ground spices; bottle and use. Many variations can be made by using nutmegs, white peppers, cayenne, &c.

**SPINACH**—Said about Spinach: "Spinach, to be truly enjoyed, should never be eaten without liberal saturation of gravy; and French epicures say, 'Do not forget the nutmeg.' This vegetable goes excellently with swine's flesh in every shape, but especially ham, the stimulating flavor of which it greatly modifies." "A gentleman who was fond of having his vegetables good, managed his spinach after this fashion: Say it was boiled on Monday, and sent to the table, properly seasoned, as the cook supposed; it went away untouched. The next day it was warmed, with an additional piece of butter, and again not eaten; and so on for four or five days, each time absorbing more butter; until our gourmand, finding it sufficiently good, made an end of it." "Spinach is often cooked in France with white wine. There is a popular saying, "*Cela mets du vin dans vos epinards*" ("That puts wine in your spinach"), referring to a slice of good luck. But I am informed that the dish thus prepared is not very tasty, and that *epinards au jus* or *au beurre* are in every way preferable." Fontenelle was a great epicure and was inordinately fond of spinach. He had a friend who frequently dined with him who was equally partial to the succulent vegetable but they differed in their preferences of the mode of dressing, for while Fontenelle preferred it *a la creme*, the friend chose it dressed *au beurre*. In consequence it was customary when they dined together to have the spinach divided and dressed differently. One day Fontenelle was awaiting his friends arrival and the spinach was ready for the final dressing when instead of the one expected there came a messenger saying the friend had suddenly dropped dead. Fontenelle thought a moment, then turning towards the kitchen he said: "Tell the cook to dress *all* the spinach *a la creme*;" and without further comment he went to dinner. **SPINACH DRESSED IN GERMAN FASHION**—Wash the spinach clean and boil for a quarter of an hour with some salt. Then squeeze quite dry, and cut very finely. Mix six ounces butter, one ounce bread-crumbs, and some very finely minced onion, and a quarter of a pint of cream or good milk. Boil all up together with the spinach, and serve. **CANNED SPINACH**—The latest novelty in American canned provisions is canned spinach, which is already cooked, and only requires warming by immersion of the tins in hot water to be ready for table. One three-pound can contains about one peck of spinach, measured in the green state. **EPINARDS A L'ANGLAISE**—Boiled, drained and buttered as in paragraph above. **EPINARDS A LA CREME**—

## SQU

Spinach cooked and mashed, cream and sugar added, served with *croutons* of bread fried in butter.

**EPINARDS AU JUS**—Spinach with gravy. **EPINARDS A L'ALLEMANDE**—Spinach in German fashion.

**SPINACH A LA MAITRE D'HOTEL**—Boiled, drained, seasoned with butter, salt, pepper, nutmeg and sprinkling of vinegar. **SPINACH, AMERICAN STYLE**

—With a thin slice of hot roast ham on top. **SPINACH SOUPS**—Spinach pounded and rubbed through a sieve is made into several varieties of soups, as purée of spinach, cream of spinach, spinach with sorrel, and with various additions of other vegetables, rice or pastes. **SWEET SPINACH**—Cook the spinach in fresh butter; when done, stir in some pounded macaroons, sugar, grated lemon-peel, and a pinch of salt. Hand sponge fingers with this dish.

**SPICE CAKES**—Various, as ginger cake with mixed spices, fruit cake well spiced and small cut-out cakes of the ginger-snap kind.

**SPONGE CAKE**—Made of 8 eggs,  $\frac{1}{4}$  cup water, 1 lb. sugar,  $\frac{3}{4}$  lb. flour. Sugar, water and yolks beaten together, flour stirred in, whipped whites last. **SPONGE DROPS**—Teaspoonfuls of the above mixture dropped on paper, dredged with sugar and baked. **SPONGE PUDDING**—Sponge-cake mixture steamed in a mould.

**SPRAT**—A small sea-fish, in appearance something like a sardine; formerly supposed to be the young herring. It appears at certain seasons in English waters in immense numbers and becomes extremely abundant and cheap in the markets.

**SQUAB**—American name for young pigeons. The methods of cooking are the same as for quails and young chickens. Squab pie, like pigeon or chicken pie.

**SQUAB PIE, DEVONSHIRE**—In Devonshire they have a special local pie, which is "fearfully and wonderfully made." It consists of a layer of sliced apples, a layer of sliced onions, and a layer of meat; the meat layer is well seasoned with pepper, salt, and a liberal allowance of sugar. They proceed thus until the pie-dish is filled; it is then covered with a crust. In spite of its eccentric ingredients, it is very good eating, and squab pie and clotted cream are the two best things to be got in Devonshire.

**SQUASH**—There are two classes of vegetables with this name and several varieties of each. The summer squashes are like the English vegetable marrow, greatly esteemed as a mashed vegetable, but very watery until dried down. The winter squashes are as mealy as potatoes and used in the same ways. They are as large as pumpkins and deeper colored.

**SQUID**—The cuttle fish; abundant in the Pacific; fished for and taken in large quantities by the Chinese and dried for use and sale.

**SQUIRREL**—"The squirrel, a charming little animal, which ought never to please but when alive,

## STA

often appeared at Rome among the most elegant dishes of the feast. At first it was only eaten by caprice; unfortunately for the little animal, it was found to be very nice." "The usual way of cooking squirrels in France is the same as for pullet stewed *a la chasseur*, which dish the squirrel, thus prepared, is said greatly to resemble. Squirrel is a favorite *mets* in many French country houses. BROILED SQUIRREL—Young squirrels are flattened out and broiled the same as chickens. POTTED SQUIRRELS—Baked in a jar in the oven. (*See Fugged Hare and Potted Rabbit.*) SQUIRREL STEW—(*See Cumberland Stew.*)

STARCH — FRENCH LAUNDRESSES RECIPE — Make two gallons of starch the ordinary way with water, then melt in half of a common candle. Set it out of doors till cool enough to stir round with your hand and then mix half a cup of raw starch and stir in. Take off the skin that will form on top. "Anybody can iron with it."

STEAM BREAD -- A recent invention. It is made of the very finest flour, and baked in air-tight pans, which enclose it on all sides. It is thus baked in its own steam and possesses a flavor peculiarly its own.

STERLET—A Russian river fish: a small kind of sturgeon.

ST. HONORE CAKE—The *choux* paste, same as for queen fritters (*which see*) laid in form of a border around a pie-paste bottom crust and baked; when done the cake is filled up in various ways, as, with pastry, cream or custard bordered (on top of the puff border) with sugared cherries or branched fruits; or with the pastry cream mixed with whipped cream, etc.

STILTON CHEESE—An English cheese, very choice and dear. It is made small in size and drum-shaped, is cream-colored, and has a rough or wrinkled crust. Just at the time this cheese has become fashionable in the United States it is giving way in England to gorgonzola, the new favorite; the complaint against Stilton being that it is not kept up to the former high standard of quality that made it world-renowned as a dessert cheese. Stilton, it seems, was first made by a Mrs. Paulet, of Wymondham, near Melton Mowbray, who supplied a celebrated sporting innkeeper, named Cooper Thornhill, of the Bell Inn, Stilton. Thornhill got a great name for his excellent cheese, and used to sell it for half a crown a pound, a lot of money at the time. In following English customs in this country it is apt to be forgotten that over there cheese is not thought to be fit to eat until it is "ripe." An intimation of what that means is conveyed in this: "The late Charles Mathews used to tell, with great glee, a little story of Charles Lamb which he vouched for as authentic and believed to be unpublished. One evening Mary Lamb took a sudden and violent fancy for some Stilton cheese for supper, an article of which there was not a scrap in the house. It was very

## STR

wet, and getting rather late; but Charles, with that selfdenial which showed itself in a life-long devotion to his sister, at once volunteered to try whether any could be got. He sallied forth, and reached their cheesemonger just as the shutters were being put up. In reply to his demand, he was assured that he could have some fine ripe Stilton; and the shopkeeper proceeded to cut off a slice. As it lay on the scales, Lamb's attention was forcibly arrested by the liveliness of the surface of the "fine ripe Stilton." "Now, Mr. Lamb," said the cheesemonger, "shall I have the pleasure of sending this home for you?" "No, th-th-thank you," said Charles Lamb. "If you will give me a bit of twine, I cou-cou-could p'raps l-l-l-lead it home!"

ST. PIERRE—Name often met with in foreign menus; it is a sea-fish, the John dory.

STRAWBERRY—A prime luxury in its raw state when fresh, and good again in the form of preserves or jam, but a very poor fruit for stewing or pie-making. The best combinations with pastry instead of in pies are the STRAWBERRY MERINGUE—A sheet of cake such as genoise, or butter sponge cake, or regular sponge cake (baked), thickly covered with ripe berries and sugar, upon these a thick coating of soft meringue (*see meringue*) with sugar sifted on top; baked enough to cook the meringue but not the berries, and the other popular and wellknown American dish of cooked paste with raw strawberries, known as STRAWBERRY SHORTCAKE—The domestic form of this is what the name implies, a flat cake of short-paste about  $\frac{3}{4}$  inch thick after baking is split open and a thick layer of strawberries, sugared, spread between, and more on top. The paste may be made of  $\frac{3}{4}$  lb. butter rubbed into 1 lb. of flour and mixed with water. Some, however, use bisquit dough made light with baking powder. The best is puff short-paste, of fully  $\frac{3}{4}$  lb. of butter to 1 lb. of flour, made by rolling in the butter in flakes instead of rubbing in, and giving the paste 8 rollings in all. The bakers, of course, make that which sells the best, and strawberry meringue as above described, made either with or without meringue, is the popular "strawberry shortcake" of the shops and lunch houses, meringue being a foreign word and the cake combination tasting as sweet by the familiar home name. MAMMOTH STRAWBERRIES—The large berries served fresh should have the stems left on to hold them by; they are dipped in powdered sugar as eaten. STRAWBERRIES AND CREAM—This usually now means with ice-cream. It should be pure cream and not a custard mixture. Otherwise the berries picked from their stems are served in saucers with powdered sugar and cold cream separately. CLARET AND STRAWBERRIES—Some people tell you that you should not drink claret after strawberries. They are wrong, if the claret be good. The milky taste of good claret coalesces admirably with the strawberries, somewhat like cream. If the claret be bad, it is quite a different affair; and suspect it if you



## STU

find the master of the house anxious not to make the test." "Well, and did you not think him quite right about claret coalescing with strawberries? The French do, at any rate. Your dish of 'strawberries and cream' is unknown here; you probably remember the story about the horrified 'Whatever is this for?' that came from a French gentleman to whom a plate of mashed strawberries was presented at a garden party during a recent season. Here claret is added to the strawberries instead of cream or milk, and an admirable improvement it is on the latter. Only, as Maginn says, the claret must be good."

**STURGEON**—"The lordly sturgeon, which may be recommended to people with tolerably good digestions, larded with fillets of eel and anchovy, and basted with thick cray-fish sauce." **A STURGEON OF FULL SIZE**—At the Tivoli restaurant was recently exhibited the head of an exceptionally large



STURGEON—ESTURGEON.

sturgeon caught on the Dogger Bank, and consigned to Mr. T. Kent, of Billingsgate. The weight of this royal fish was 644 pounds; its measurement being 11 feet 2 inches long, and 5 feet 2 in. in girth. **STURGEON IN THE GREAT LAKES**—The sturgeon is taken in abundance in Lakes Michigan and Superior, and as the price in market varies according to the demand of the curers, the fish are kept alive in pens at the fishing stations until orders are received by telegraph to ship to the city. **SMOKED STURGEON**—Smoked sturgeon is now included by epicures among fish delicacies. About a hundred pounds at a time are placed in a brick furnace, with eight-inch walls, leaving an

inside square of about three feet. A very hot fire being placed directly underneath, the fat as it melts generates its own smoke. Care has to be taken that the flow is not so heavy as to produce too fierce a flame, as then there would be a charred fish, which is not desirable. The time necessary to smoke sturgeon is about six hours. Eels undergo a like process, and are very palatable. There is a peculiarity about the smoking of haddock, inasmuch as it is smoked entirely with sawdust. Of course it can be smoked by other means, but the best method is the sawdust fire. **DAME D'ESTURGEON AU FOUR**—Baked slice of sturgeon. Lay a fine slice of sturgeon in a tin dish, sprinkle with a little olive oil, the juice of a lemon, chopped mixed herbs, salt and pepper; bake, and when done, place in another dish, pass the sauce through a tammy, pour over the fish, and hand *re-moulade* sauce separately. **ESTURGEON EN FRI-CANDEAU**—Sturgeon cut in thick slices, larded,

## SUG

stewed with bacon and mushrooms and glazed. **ESTURGEON BRAISE**—Sturgeon larded and braised with wine stock, herbs, onions and ham. **ESTURGEON A LA BOURGUIGNOTTE**—Baked cut of sturgeon served with Bourguignotte sauce. **ESTURGEON A LA ROYALE**—A sturgeon tied up in the form of a cushion, covered with forcemeat, ornamented with slices of truffles and red tongue. **ESTURGEON GRILLE SAUCE PIQUANTE**—Broiled sturgeon steak with piquant sauce. **ESTURGEON A LA REINE**—Small sturgeon steaks larded with strips of truffles and lean ham, parboiled in seasoned broth; put into oiled papers with chopped herbs, folded up and broiled in the papers. Served without the papers with butter sauce around. **TRANCHES D'ESTURGEON**—Slices, or sturgeon steaks.

**SUCRE (Fr.)**—Sugar. **SUCRES**—Sweets.

**SUCCOTASH**—Indian name of a mixture of butter beans and corn cooked together, a common and popular American vegetable dish.

**SUEDOISE**—Swedish dish of fruits, compotes, placed upon rounds of fried bread, and built up in pyramidal form around a center-piece of fried bread.

**SUGAR**—In cooking such sweet preparations as are made with milk or cream, whether for custards, puddings, sauces, or whatever else, the sugar should be mixed in before the milk goes on the fire, and it will prevent burning on the bottom. This simple precaution does away in many instances with the necessity of following the onerous course demanded by most cook-book writers, to "stir the mixture (of eggs, milk, flour, etc.) constantly till it boils." The milk and sugar together take care of themselves, and when poured to the eggs, starch, or steeped tapioca the cooking is almost finished and little time lost. **DEGREES FOR BOILING SUGAR**—These are the smooth, the thread, the blow or feather, the ball, the crack, the caramel. 1st.—Smooth, or 215 degrees by thermometer; as an example take 12 lbs. of loaf sugar, to which put 3 pts water; as soon as it boils see that all the sugar is dissolved, if not use the spaddle to assist in doing so, let it boil for five minutes or so, dip into it the handle of a teaspoon, draw it between the finger and thumb; if on working them together they feel slippery, that is the first degree of smooth; this degree can be used for crystallizing liqueurs and various other goods. 2d.—Thread, or 230 degrees by thermometer. In the course of a few minutes the sugar passes into this degree; having soaked the previous sugar off the spoon, try the boil again, close your finger and thumb together and gently part them, when, if you perceive a thread-like appearance between them, it has passed into this degree, which can now be used for making liqueurs or bonbons, &c. 3rd.—Blow, and feather, 240 degrees. In two or three minutes from the last sugar passes into this degree; dip a small skimmer or slice with holes in it into the sugar, drain it off quickly and blow hard through them, you will per-

## SUG

ceive bladders and feathery particles pass away. This is the blow or feather, very useful degrees, and can be used for candying peel, fruit, &c. 4th—The ball, or 250 to 255 degrees. About the same time as the last this degree arrives, have some cold water handy. Take a little sugar out of the pan with the handle of the spoon, dip it into the water, and if it is tough and you can work it about with the finger and thumb like a pinch of hot bread, that is the ball which can be used for candies or creams, if jams or preserves are to be mixed in after being worked into cream by the spaddle. 5th—Crack, 310 to 315 degrees. Use the same process in testing as the last, but quickly; take a little out of the pan, put it into cold water, when it will crack, or slip it off quickly and bite it well; if it *crunches* and leaves the teeth without sticking to them, pour the sugar out instantly on your slab. This is the most useful degree to the hard confectioner for all purposes of boiled sugars. (N.B.—In trying this last degree, unless an experienced workman, the pan must be lifted off the fire.) 6th—Caramel. It is not necessary to try this degree in the same way as the last; the instant the sugar changes color, which must be closely watched, as it occurs rapidly, it must be poured out, or if not required on the slab but for other purposes, such as spinning sugar, &c., place it in a tub of cold water the size of the bottom of the pan, to stop the heat, or it will turn very dark. This degree is mostly used for spinning sugar for ornamental table use. To PREVENT GRAINING—As a rule, put about a quarter of an ounce of the cream of tartar to an eight or ten pound boil, according to the strength of sugar; a teaspoonful of the strong acids, or tablespoonful of lemon juice or the best malt vinegar to the same quantity of loaf sugar to reduce its strength. The same effect is produced by using "glucose," a fifth part of which to any quantity of sugar will reduce it to the required working condition. The advantage of this is in increasing the bulk at a small cost. Although, strictly speaking, this is an adulteration, it is quite wholesome. THERMOMETERS FOR SUGAR BOILING—Are made of copper, degrees properly marked for the purpose, the scale beginning at 30, the degree for simple syrup as used in making *mousses* (ice creams) being 32. Can be purchased at confectioners' supply stores.

SUGAR ROCK WORK, or honey-comb candy, used for building ornamental pieces. Having made a wooden frame about 12 or 16 inches square, and 4 inches deep, place it on a wet slab or wooden bench; take 7 lbs. loaf sugar (no lowering), boil to the caramel degree, previous to which, in a pound jar three parts filled with fine powdered sugar, mix the whites of two eggs, beat it well till stiff; when the sugar comes to the degree required, put in any color you like, take it off, pour icing in and immediately agitate the whole with the spatula; in two or three minutes it will rise to the edge of the pan, let it fall again and continue stirring, as soon as it begins to rise the second time, instantly pour it into the frame.

## SWA

Many persons fail at this process from pouring out at the first rising, which on the slab becomes perfectly flat and heavy. When cool remove it by passing a fine string or long palate-knife underneath it.

SUGAR SPINNING—Or web decoration. Sugar boiled as above to the beginning of *caramel*, or, take 2 lbs. white sugar,  $\frac{1}{2}$  teaspoon cream tartar, 1 pt water, boil to the crack for white web, or to the beginning of *caramel* for yellow. Let it cool for 10 minutes, then place your ornamental piece with the stand and all on the floor, spread a newspaper to catch the waste threads. Have a bunch of wire with 8 or 10 ends or prongs, dip the wire prongs into the hot sugar, and as it drains off you will swing it around or across the ornamental piece to make a silky veil of fine threads till you have all the sugar used up. If not wanted that way, lay a broom on the table with the handle projecting over and swing the threads back and forth across the handle. When done run your hand under and cut the threads loose from the floor or paper and lay them in a bunch or skein where wanted. In this form spun sugar is used to represent water flowing in a cascade over rocks made of the honey-comb candy above mentioned, or flowing out of a dolphin's mouth.

SUNSHINE CAKE—Yellow cake made of  $1\frac{1}{4}$  lb. sugar,  $\frac{3}{4}$  lb. butter, 1 pint of yolks beaten with 1 pint of milk,  $1\frac{1}{2}$  lbs. flour,  $\frac{1}{4}$  lb. rice flour, 2 teaspoons baking powder, lemon juice and rind.

SURPRISES—Culinary surprises, or dishes designated *en surprise*, are things which prove to be other than they purport to be, as when a cake filled with cream is made and colored to imitate a ham, or a baked potato is found to conceal a filling of minced meat or a bird.

SWAN—Lately figured on the menu of Lingner's Restaurant. A roast swan, which weighed before trussing 35 lbs. As to its culinary treatment, the bird was larded and stuffed with chestnuts and truffles, braised before roasting, and finally served up to the double accompaniment of red cabbage and port-wine sauce. There was a good demand for the dish, and roast swan was soon reported "off." Twenty-nine "portions" were served, at 30 cents each. Mr. T. Vallet, of the Swan Hotel, Alton, sends us the following recipe in the hope that it may be "of some use to a confrere, who finds himself face to face with a cygnet for the first time." "The following will be found a very good way to treat it: When the bird is well cleaned, rub it inside and out with a spoonful of finely-bruised cloves, fill it with a stuffing made of 2 lb. of beefsteak, chopped very fine, well seasoned, adding 4 oz. of butter and some chopped shallot. Sew up the bird and tie on the spit with care, so as not to let the gravy escape. Cover with buttered paper. The fire should not be too fierce, as the bird is apt to acquire a high color. A cygnet of 15 lbs. requires a little over two hours. Half a pint of port-wine boiled with a little glaze mixed with the gravy that comes from the roast is

## SWE

to be poured on the dish. It should be served with hot currant jelly in a boat." The breeding of swans for market is suggested by a correspondent as an industry likely to bear profit. He writes: "I dined the other day at a house where for a party of twelve a swan was the *piece de resistance*. It was pronounced to be something between a goose and a roast hare for flavor, and, being a cygnet of last summer's rearing, it afforded, some said, as much meat, and some rather more, than a first-class turkey." CIGNE and CIGNET are the French for swan and young swan.

**SWEETBREADS**—Both the thymus gland and the pancreas, are included in the culinary name sweetbread, the substance of both being very similar and either answers the same purpose; the pancreas or stomach (or "heart") sweetbread being generally accounted the best, although the throat sweetbread is freer from veins and more delicate in texture and therefore often recommended in spite of its irregular shape, which is like a piece of pulled-off fat. The cooks rely upon the butchers for these, and as it never falls to a cook to have to kill and dissect anything larger than a turkey, he takes what the butcher furnishes him without much question concerning the localities where they are found within the animal, and then begins his part of selecting them, and cooking them according to their adaptation, the best in shape to be sliced, larded, broiled, baked, braised or otherwise cooked in good form; the unshapely, irregular, torn or diminutive ones to be cut or minced, served in patties, or mixed with other meats and mushrooms in various garnishes, or in the form of croquettes, rissols or kromes-kies, or the form of scalloped sweetbreads and, perhaps, if they be plentiful enough to devote to such a purpose, in soup. Sweetbreads are not such very choice eating, they have but little flavor, but they are tender meat, like fat without fatness; they are white and adapted to be ornamented with strips of larding of black truffles, green cucumbers, or pistachio nuts, or red smoked or corned tongue, and they take the flavors of herbs, wines and well-made sauces. That is why they are sought after and necessarily in the nature of things they are scarce and have been kept among the exclusive delicacies, that it was thought common folks had no business to want. People who board in hotels, however, want everything. There is a large hotel in an English city, whose proprietors are trying their level best to set an American sort of a table, but to do that they have to send over to France for some of their supplies; they cannot get either tenderloins of beef or good veal sweetbreads from their home butchers. The French eat more veal, anyway, than any other people, and calves' sweetbreads must be so much the more abundant there. These are not the only kinds of sweetbreads, however, for lambs furnish the most delicate of all, and by reason of their smallness they must be the rarest and most exclusive dishes which are made of them. **COOKING SWEET-**

## SWE

**BREADS**—Sweetbreads have taken their stand as an ubiquitous entrée, and few elaborate menus are arranged without them. Patties of sweetbread and truffles are in high favor and seem to be the caterer's standard dish. In whatever way they are to be afterwards dressed, sweetbreads should always be steeped in water for two or three hours, then boiled from 5 minutes if very young and tender, to 1 hour if they are from very old calves, as the butchers sometimes bring them, and after that pressed between two dishes until cold. **ESCALOPES DE RIS DE VEAU**—Scallops or slices of sweetbreads prepared by cutting the cold and pressed sweetbreads into small thick slices, spreading them over with a croquette mixture of minced onions, mushrooms, parsley, seasonings and panada, eggging, breading and frying them. Brown sauce containing sherry. **COQUILLES DE RIS D'AGNEAU**—Paris restaurant specialty. Lamb's sweetbreads scalloped in shells. The sweetbreads are cut in dice, cut mushrooms mixed with them and both slightly fried in butter; rich white sauce added, filled into table-shells, bread-crumbs on top and melted butter; browned in the oven. **FRICANDEAU OF SWEETBREADS**—The sweetbreads already cold and pressed are larded with strips of salt pork on the best side, braised in stock with herbs and vegetables; the liquor strained, boiled down to glaze and poured over them; served on a bed of spinach. **RIS DE VEAU A LA VILLEROI**—The sweetbreads already partly boiled, pressed and cold are cut in slices, coated with thick white sauce, breaded, egged, breaded again and fried; served with white sauce and any dressed vegetable. **RIS DE VEAU A LA PONTELLE**—White fricassée of pieces of sweetbreads in cream-colored sauce with mushrooms. **RIS DE VEAU A LA COLBERT**—The sweetbreads already partly boiled, pressed and cold are split, buttered, dipped in bread-crumbs, broiled; served with colbert cauce. **RIS D'AGNEAU A LA JARDINIÈRE**—Lambs' sweetbreads larded, braised and glazed, served with a jardinière garnish of mixed vegetables. **RIS D'AGNEAU AUX PETITS POIS**—The preceding with peas, can be served with asparagus points and other vegetables and named accordingly. The French name of sweetbread serves well to show how easy it is to be wrong in wording a bill of fare; "ris" is not only "sweetbread" but the same word stands for "smile." An American lady at a French hotel once astonished and amused a party of her country people by translating the dish "*ris-de-veau a la financiere*," "the smile of a calf at the banker's wife," and was not far out of the way. To make it the more hazardous writing, while ris is sweetbread, "riz" is rice, thus: **CASSEROLE DE RIZ AUX RIS D'AGNEAU**—A baked shape or border of rice filled with lambs' sweetbreads in sauce. **RIS DE VEAU FRITS**—Veal sweetbreads fried. **RIS DE VEAU A LA PROVENÇALE**—Larded, braised with bacon, garlic, tarragon leaves, the liquor strained and boiled down to glaze. **PETITES CROUSTADES DE RIS DE VEAU**—Patty cases shaped out of bread,

## SWE

fried and filled with sweetbread in sauce. **BLANQUETTE DE RIS DE VEAU AUX TRUFFLES**—Round slices cooked with slices of truffles in cream colored sauce. **RIS DE VEAU A LA TOULOUSE**—Larded, braised, served with a Toulouse garnish of cockscombs, mushrooms, etc., in white sauce. **RIS DE VEAU PIQUES A LA TURQUE**—Larded, braised, glazed, served on a border of forcemeat with rice in the center. **RIS DE VEAU EN BIGARRURE**—Like an epigramme; half of them larded, braised and glazed and half breaded and baked brown, served in pairs with tomato sauce. **ESCALOPES DE RIS DE VEAU EN CAISSE**—Small rounds cut with a tube cutter; with "fines herbes" in buttered paper cases with bread-crumbs on top, baked. **CROQUETTES OF SWEETBREADS**—Cut very small or chopped, stirred in a very thick sauce with seasonings; rolled up when cold, breaded and fried. **CUTLETS OF SWEETBREADS**—The croquette mixture patted into the shape of mutton chops; a piece of raw macaroni to represent the bone, breaded and fried or baked; served with tomatoes or other vegetables. **RISSOLES OF SWEETBREADS**—The croquette mixture rolled like very thin sausages, rolled up in thin pie-paste and fried. **KROMESKIES OF SWEETBREADS**—The croquette mixture rolled like bottle corks, rolled up in very thin slices of boiled bacon, dipped in fritter batter and fried. **SWEETBREADS WITH KIDNEYS A LA CORDON BLEU**—Sweetbreads larded thickly with truffles, spread over with pounded pistachio nuts moistened with white of egg, baked in buttered papers; served with a border of broiled lamb's kidneys and port wine sauce. **CURRIED SWEETBREADS**—Large slices of sweetbreads fried with onion and butter, stock added, flour, butter and curry powder stirred in; served with rice. **MEDALLIONS DE RIS DE VEAU**—Tomatoes raw, peeled, are cut in halves and dried down in the oven; round slices of cooked sweetbreads sandwiched between two halves of tomato, breaded and fried; served with fried parsley and supreme sauce. **SWEETBREAD SOUP OR POTAGE A LA COMTESSE**—Made of veal stock, cream, cubes of sweetbreads and fried *croutons*. **SWEETBREAD SOUP A LA PONTOISE**—Sweetbreads in small pieces with raw ham, leeks, white wine, in chicken stock thickened with white roux. **SWEETBREADS (RIS DE VEAU)**—Are in Paris served larded with a garnish of *pointes d'asperges*, that is, green asparagus tops, boiled, with a lump of butter added. This tasty dish is tariffed from 75 centimes to 7 francs, according to the restaurant at which it figures on the menu. **ENTREE OF SWEETBREADS**—Take 4 sweetbreads, soak and blanch them, then stew in milk and water, with mace and lemon-peel; when cooked enough, strain the gravy, and thicken with a tea-cup of cream and a little corn-flour. Roll up eight or ten quite thin pieces of bacon, and fry them crisp, and set them on end in the middle of the dish, then lay small bunches of asparagus at intervals on the top of the bacon, cut the sweetbreads into suitable size pieces, and put them round, then pour the sauce

## TAM

over them so as to leave the bacon and asparagus clear.

**SYLLABUB**—Old English name of whipped cream flavored with wine and sweetened. **SYLLABUB WITH JELLY**—Gelatine jelly of any flavor or color served in a border of whipped cream.

**SYRUPS**—Pure fruit syrups are extremely useful in hotel cooking, being always ready for sweet sauces, sherbets, ice creams, etc. **RASPBERRY SYRUP**—The juice of raspberries expressed either by twisting up tight in a strong towel or in a fruit-press made for such purposes. To 1½ pints of juice 2 lbs. of sugar is added, melted over the fire, boiled a while, skimmed, filled into bottles and corked. **RED CURRANT SYRUP**—This and other fruits by the same general rule as for raspberry syrup. **GINGER SYRUP**—2 oz, bruised ginger boiled in 1 qt water, strained, and 2 lbs. sugar added, boiled down to syrup. **SODA SYRUPS**—The foregoing with either dissolved gum arabic or white of egg added to form a head or froth on top. **PLAIN SYRUP**—For bar-keepers' and general uses: 7 lbs. loaf sugar to 1 quart water, boiled up, skimmed, strained.

## T.

**TALLEYRAND**—"The sole depository on the entire tradition of the State," Talleyrand, even at the age of eighty, ate but one square meal in the day, his dinner; and every morning he required the *menu* of it from his *chef*. He would rise at ten, dressing himself even after the hands had got rebellious; and half an hour later would have an egg, a fruit or a slice of bread and butter, a glass of water with a dash of madeira in it, or perhaps only two or three cups of camomile tea, before beginning "work." No coffee, no chocolate, and "China" tea very rarely. He dined at eight in Paris, at five in the country, well and with appetite; taking soup, fish, and a meat entrée, which was almost always of knuckle of veal, braised mutton-cutlets, or a fowl. He would sometimes have a slice off a joint; and he liked eggs and custards, but rarely touched dessert. He always drank a first-rate claret, in which he would put a very little water; a glass of sherry he did not despise, and after dinner a *petit-verre* of old malaga. In the drawing-room he would himself fill up a large cup with lumps of sugar, and then the *maitre d'hotel*—Carême, no less—would add the coffee. Then came forty winks; and afterwards he would play whist for high stakes. His senile eye-lids were so swollen that it was a vast effort to open them to any width, and so he often let them close, and "slept" in company that bored him. He still continued to call up a secretary at night, and dictate to him through the closed bed-curtains.

**TAMARIND**—The fruit of the tamarind tree which grows in the West Indies; it is in the form of a pod containing an acid pulp; the pods are packed in casks filled up with syrup. Eaten as a sweetmeat and used to make a cooling drink.

## TER

**TERRAPIN**—A salt-water tortoise. The subject of more speculative puffery and ingenious advertising to advance prices to the most absurd extremes than any other food-product of America. Every crawling, sliding, sun-hasking, mud-wallowing reptile of the turtle or tortoise kind now goes to pot in the name of one particular variety called the diamond-back, and as all are gelatinous, all devoid of any decided or characteristic flavor, and all are when dressed highly seasoned and alike flavored with sherry, to distinguish one variety from another by the taste is impossible; and to pay \$4 or \$5 for a plateful, or \$10 or \$20 a quart for the prepared article is sheer infatuation, a fashionable craziness, a confession to being the dupe of cunning advertisers. Terrapin or tortoise is good eating as cooked in Maryland country-houses, as are soft-shell turtles, hawk's-bills, and snapping turtles likewise; they are all gelatinous, tender, and susceptible of being highly flavored by skillful cookery. **COOKING TERRAPIN**—There are four principal ways, the white fricassée, brown fricassée, the terrapin pie (like chicken pie), and the baking in the shell to be eaten with salt, pepper, and butter. These terms are used here, because chicken fricassées or stews are very generally understood, and terrapin is the same with the addition of more or less wine, according to circumstances or individual tastes. **TERRAPIN, MARYLAND STYLE**—The cream stew or white fricassée. The terrapin dropped into boiling water and allowed to remain for about 15 minutes; then handled with a towel, and the outer skin of the legs hastily scraped off before it becomes set fast. The terrapin is opened, gall bladder sought for and removed without breaking, intestines thrown out, eggs saved, and liver; flesh removed from the shells, divided in pieces, simmered in butter and the terrapin liquor collected from the shells while cutting up, little seasoning of mace, salt, pepper; flour stirred in, sherry and boiled cream; the eggs added at last. **TERRAPIN, BALTIMORE STYLE**—The same method with brown sauce and wine instead of cream and wine. In either case the first scalding is only a parboiling, and the blood still runs inside, and the cut-up terrapin must cook about an hour afterwards to make it gelatinous and tender. **TERRAPIN SOUPS**—Cream of terrapin is made of terrapin broth strengthened with veal or chicken broth and vegetable seasonings, cream and butter, pieces of terrapin and thickening of yolks mixed in without curdling with too much heat, and chopped parsley. Terrapin soup brown is made same as turtle soup.

**THON** (Fr.)—Tunny; a fish.

**TIMBALE**—Thimble or drum shape; anything formed in a plain round mould.

**TOMATOES**—These brilliantly colored fruits are most wholesome and delicious to those who have once acquired the taste for them. To our mind there is no more delightful salad at this time of year than a couple of well-ripened tomatoes sliced, sparingly

## TOM

flavored with shredded onion, seasoned with pepper and salt, and liberally sauced with Provence oil and white wine-vinegar (two parts of oil to one of vinegar.) **COOKING TOMATOES**—"There are two modes of adapting the use of the tomato to man—the hot and the cold. For the latter the Spaniard is supreme; but the Provençale alone knows how to dress it hot. The people of Bordeaux (where all the women are born cooks) imagine they can supply you with a dish of stuffed tomatoes. It is a mistake. Firstly, their soft, often hazy, south-western climate does not furnish the fruit; secondly, they have not the oil; and, thirdly, they have not the 'trick' of it. No! there are a few things for which you must go to Provence (of which Messer Francesco Petrarca—a rare *gourmet* in his day—was well aware.) You must go to Aix for its oil, to Barbantane for its asparagus, to Cavaillon for its aubergines and its melons—those Sir John Falstaffs of the kitchen garden; to the Fontaine de Vaucluse for its eels and its fat *becque figues*; but to Avignon for its *tomates farcies*. This dish is the business of a day. First take a

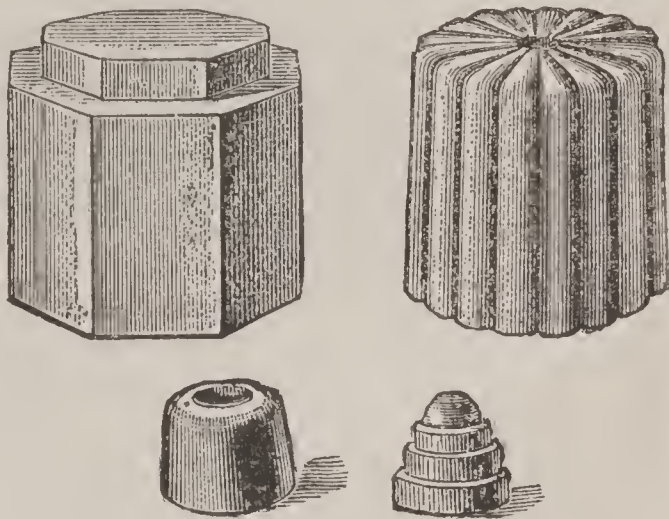

TIMBALE MOULDS.

shallow copper *tourtier* and see how many tomatoes of equal size will fit into it, very closely together. Next take out each tomato, cut off one-third of the upper part, and put it (face downwards) into a plate upon a pinch of strewn salt. Leave the fruit for about three hours, until all the acid juice shall have exuded. This prevents the stupid complaint of ignoramuses, that 'tomatoes are unwholesome, and they are afraid of them.' When all the 'vice' has been taken out of them, range your 'apples' in the *tourtier*, with a teaspoonful of oil at the bottom to keep them moist, and then delicately apply to each one a light covering of the forcemeat described below, introducing the wee-est portion of it into the orifices of the cut fruit. When this is complete, set it on a charcoal-fire covered over with ashes, and let it stew gently till it is ready to serve. The time usually required is two hours or two hours and a half. The 'stuffing' consists of yolk and white of eggs boiled hard, of tarragon and chervil, of breadcrumbs (sifted), of an onion or two (cooked), of a spice of garlic; the whole well chopped and mixed together

## TOR

(not till it is a paste), and at last having some grated Gruyère cheese (*de première qualité*) added on to it. All this 'stuffing' must be so delicately spread over the tomatoes that it forms a manner of light crust; and previously to being carried to table it must be cunningly 'browned' by a very skilful hand. The whole time of its stewing it has to be unremittingly watched, for if it gets dry, oil must be gently dropped in, and if a danger of wet shows itself, it must be obviated by a pinch of the finely-grated cheese. It is a *plat* calling forth every quality of a first-rate cook; but when it succeeds, it amply justifies the high reputation of the Provençal chefs."

TORTUE (Fr.)—Turtle.

TOURNEDOS OF BEEF—Small thin beef-steaks briskly fried. They are served in crown-shape with a sauce in the center.

TRAGACANTH—Gum dragon; used for making gum-paste ornaments for cakes. It becomes like flour paste when soaked in water, and is then mixed with sugar and starch.

TRIBE—It consists of the first stomach of the ox. The fibre differs from that of meat; is both nutritious and of easy digestion. To cleanse tripe is quite a trade of itself, it being an object to make the finished product as white as possible; the method is to steep the tripe in lime water or in lye water for 2 or 3 days and then scrape away the outer coating, after which it is soaked in several waters for some days longer. The hotel buyer finds it in market ready-prepared, either uncooked and fresh or in kegs in spiced vinegar ready-cooked. The raw tripe requires 10 hours slow boiling to make it tender for the subsequent modes of dressing; the soured tripe is used in all the same ways, and if desired can be divested of most of the vinegar by soaking in water with a little soda; simple washing in one water is, however, generally a sufficient preparation. SAID ABOUT TRIPE—"The Greeks devoured tripe with much complacency, regarding it, indeed, as a dainty fit for heroes. It formed the chief dish at the banquets of men who met to celebrate the victory of mortals and gods over the sacrilegious Titans."—"The Carlton Club has a famous specialty of broiled honey-comb tripe with butter."—"Well-dressed tripe with its natural accompaniment—onions—is an excellent supper-dish, as it is equally digestible as a sole."—"Those who are fond of tripe I should advise to instruct their cooks to use white crystal sugar in the cooking, say one ounce to the pound of meat, to be stirred in immediately before being served." TRIPE A LA MODE DE CAEN—"Happening to be at Caen I took steps to learn exactly how the tripe, for which this town is so famous, is prepared. Strangers sometimes wish to regale themselves with this dish; but if they happen to partake of it on a week-day, they run great risks of being disappointed, for it is on Sundays only that the wholesale manufacture takes place. Every Saturday the lovers of tripe carry dishes, soup-plates, and other receptacles to the dif-

## TRI

ferent shops. The money to pay for each portion is invariably put in the bottom of each plate. At some shops these dishes come in by dozens, and long journeys are often undertaken by customers to reserve the quantities they desire at the shops in good repute. For if the preparation of tripe is a general industry here, one only finds that fine gold-colored sauce, which is so justly appreciated, at those houses where only the best ingredients are used, one of the principal of which is the good butter of the district. The following is the recipe usually followed, and is suited to all countries: Take some fine fresh tripe, bleached and well washed in warm water. Rinse it thoroughly, and let the water run off completely. Cut the tripe into two-inch squares. Bone 4 cow-



TROPHY OF PIGEONS [BONED].

On shell-shaped dish; stand of white wax or mutton fat cast in mould.

heels, and cut them into pieces; take an ox-tail and cut it into several pieces. Take a large narrow-mouthed stone jar, put in it first a layer of tripe, then a layer of onions, next your pieces of cow-heel, then the ox-tail, then the rest of the tripe. Add a good handful of leeks, parsley, thyme, and laurel-leaves, plus 1 onion into which you have stuck 6 cloves. Cover the whole with 1 kilo of butter (2 lbs. 3¼ oz.), and 1 kilo of good fresh beef-kidney fat. Pour in 2 litres (4½ pts.) of caramelized water, 2 glasses of brandy, and hermetically close the jar. Put it into an oven, and let it bake for 10 hours. You will thus obtain tripe of most excellent quality." A TRIPE DINNER—A company having been formed to establish and conduct a number of tripe houses or restaurants, the directors had a sample dinner prepared

## TRO

where the principal dishes were "Tripe *a l'Anglaise*" (broiled), "Fried Tripe *a la Soubise*" (with purée of onions), "Tripe *a la Milanaise*" (in tomato sauce), "Baked Tripe and Onion Sauce." **TRIPE A LA CREOLE**—Cut 1½ lbs. of tripe into narrow strips, put in a saucepan with enough gravy stock to cover it, add ½ lb. of tomatoes, some chopped onion, a clove of garlic, little olive-oil, salt, Worcestershire sauce, and red peppers. Stew gently until well done, and serve. **TRIPE A LA LYONNAISE**—Cut in strips, mixed with fried onions and espagnole, or meat-gravy. **TRIPE A LA POULETTE**—Take the thickest and whitest tripe, cut it into thin slices, and put them in a stewpan with a little white gravy, 1 spoonful of vinegar, a little lemon-juice and grated lemon-peel; add the yolk of 1 egg well beaten, with a little cream and chopped parsley; shake together over a slow fire until the gravy is as thick as cream, but do not let it boil; served with sippets of toasted bread. **FRIED TRIPE**—Wiped dry, dipped in egg and cracker dust, fried. **TRIPE IN BATTER**—Pieces about 2½

## TRU

well together. **FILLETS OF TROUT**—Are prepared in precisely the same way as fillets of salmon; the fillets are dipped in beaten egg, drained, and rolled in fine bread-crumbs, and fried a light brown color in boiling lard or oil.

**TRUFFLE**—A species of fungus which grows several inches under-ground, but never appears above the surface. It is one of the articles of great luxury in France and Italy, where it grows. As it cannot be cultivated but grows spontaneously, the harvest is extremely uncertain and prices often run up to an extravagant height. This, however, is one of its attractions. Brillat-Savarin remarked: "Perhaps if they were not expensive, but were within the reach of everybody, *we* should not prize them so highly." It is said that the gray (inferior) truffle has been found in Massachusetts and Pennsylvania, and the black truffle, equal to the Perigord truffle, has been dug up in Virginia. As to the color, however, some authorities contend that the gray or white truffle is the black truffle in its unripe state.



inches square dipped in fritter batter and fried in a kettle of hot lard or oil; served for breakfast.

**TROPHY**—A general designation for a highly decorated piece of cooks' work, of no particular form, but in any form. Trophies of game are sometimes composed of cooked game of several kinds with their skins or feathers replaced, beaks and claws gilded, etc.; but any conspicuously ornamental piece may be called a trophy.

**TROUT**—Brook trout are generally fried or broiled, though the lake trout found in Hamilton County, Seneca Lake, etc., are better boiled, and served with a simple sauce of parsley and butter. **BROILED TROUT**—The following is a choice old recipe for dressing trout: Take out the entrails, cut the fish across the side and wash them; fill the cuts with thyme, marjoram, and parsley, chopped fine; set the gridiron on a charcoal fire, rub the bars with suet, and lay the trouts on, basting them with fresh butter until they are well broiled; serve with a sauce of butter and vinegar and the yolk of an egg beaten

They are found underground by means of dogs and pigs trained to hunt them by the scent. The canned and bottled truffles obtainable at the fancy grocery stores serve a purpose in decorating dishes and filling out the names of dishes in genuine style, but they possess little, if any, of the perfume and flavor of the fresh article. **A BAD TRUFFLE HARVEST**—There has been a rise in the price of Perigord truffles, and the Parisian *chefs* are much concerned at the high cost of these delicacies, which now command no less than \$3 a pound. The less savory Piedmont and Dauphine species, which fastidious cooks despise, may be had for \$2. These are sold to poultrymen and pork butchers to stuff turkeys, &c. There is so much difference in the quality and flavor of truffles, that caterers for epicurean tastes very rarely buy any but the real Perigord, which has a peculiar and delicious aroma. **A GOOD TRUFFLE HARVEST**—A Paris correspondent writes: "It is gratifying to learn that the truffle crop, now in process of gathering, is to be a very abundant one,

## TUN

and a single house at Perigeaux, which is the center of the truffle trade, purchased three and a half tons last week. Some of the truffles in this lot weighed over one pound each, this being a very uncommon weight to attain: and it may be assumed, therefore, that truffles will be cheaper than they have been for the last few seasons." **TRUFFLES A LA SERVIETTE**—Truffles in a napkin. The largest truffles are baked in the coals like potatoes, and served in a folded napkin. **TRUFFES AU SUPREME**—The best recipe for cooking truffles is Truffles au Supreme,

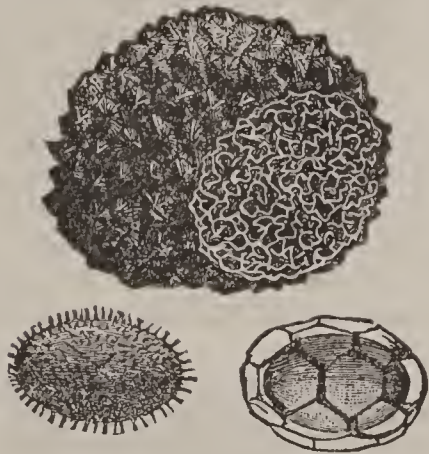

for which proceed as follows: One dozen fine truffles, black with large grain are best; put them to boil in half a botte of old madeira, with two little liqueur-glasses of fine champagne cognac, gray salt, a pinch of cayenne, a clove minus its head. Let all this boil together for the space of half an hour, then withdraw the truffles and place them in a timbale, reduce the liquor in which they have been boiled to one half, add half a spoonful of meat-glaze, "body" the sauce with some good butter, pour it over the truffles and serve at once. **TURKEY STUFFED WITH TRUFFLES**—See *Dindon Truffe*.

**TUNNY**—A fish like the Spanish mackerel, found in the Mediterranean. It is taken also in Florida waters and known as the horse mackerel. Tunny is esteemed by the Italians; they preserve it in oil and "thon" prepared in various ways is very frequently met with in European menus, but oftenest among the *hors d'œuvres*.

**TURBAN**—Crown shape; anything built up in such shape in a dish or formed in a turban mould.

**TURBOT (Fr.)**—Turbot; same in both tongues.

**TURBOT**—This is the most highly esteemed of all flatfish, not only on account of its intrinsic excellence, but because of its favorable shape for the purposes of decoration. Famous as it is, and often appearing in American menus, it is not found in American waters any more than is the sole. It is very probable that in many cases where the bill of fare offers turbot the place is filled with plaice or large flounder or fluke for a substitute; but on the other hand the English turbot is unlike most fish in being the better for keeping a short time and the fish brought over by the mail steamers are still in excellent condition, so that genuine turbot is not out

## TUR

of the question when a rarity is desired. **SAID ABOUT TURBOT**—A turbot, if kept two or three days, will eat much finer than a very fresh one; it being only necessary to sprinkle the fish with salt, and hang it by the tail in a cool place. Before putting it into the kettle make an incision in the back, rub it well with salt, and then with a cut lemon. If a turbot be boiled too fast it will be woolly." "You may serve up salmon with as much ornament as you will, but a turbot asks for nothing but aristocratic simplicity. On the day after he makes his first appearance it is quite another affair. It may then be disguised; and the best manner of effecting this is to dress him à la Béchamel." "The great French cook Carême never sent any other sauce than melted butter to table with turbot." Notwithstanding the foregoing remark a "turbot à la Carême" is now a complicated dish of boiled turbot covered

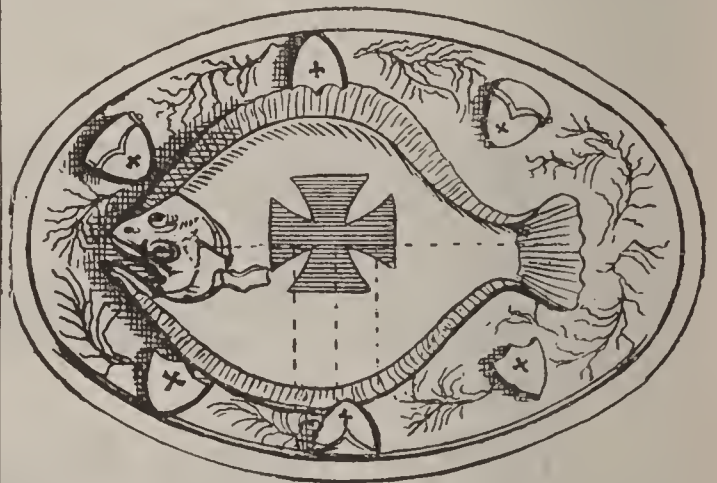

with a creamy stew of small shellfish. The turbot is especially adapted to be cooked by boiling—simmering in court bouillon—but is also cooked in all other ways of any kind of fish. **TURBOT FINS**—"The thick part of the fins and the gelatinous skin are the parts of the fish most relished by epicures. When preparing it for cooking on no account cut off the fins." **TURBOT GRILLE A LA VATEL**—Broiled small turbot served with mussel sauce and crayfish. **TURBOT A LA RELIGIEUSE**—Convent style; boiled, served in Hollandaise sauce, sprinkled with chopped tarragon, and garnished with hard-boiled egg. **FILETS DE TURBOT PARISIENNE**—Take a small and fat Dover turbot, and cut the four filets obtained from the fish into scallops, well shaped and trimmed. Prepare a forcemeat of whiting, mixed with purée of fresh mushrooms, and spread this forcemeat over the filets very smooth. A good mushroom sauce should be poured over them. **TURBOT A LA VICTORIA**—Simmered in court-bouillon till tender, dished the white side uppermost on a folded napkin or lace edged fish paper; the whole white surface sprinkled with lobster coral; decorated with stuffed olives and pickled cranberries.

**TURKEY**—A turkey cock is best for roasting, a hen for boiling; and be sure it is properly cooked, for half-cooked poultry is simply uneatable. "A turkey boiled is a turkey spoiled," runs the old pro-



## TUR

verb uncompromisingly; but a change is always pleasant, and, in spite of the dogmatic old law, a properly boiled turkey is uncommonly good eating.

**WILD vs. TAME TURKEYS**—The wild turkey is a far more excellent table bird than the domestic turkey; in fact there is no comparison. The barnyard can not give that flavor and that texture which testify to wild berries, seeds and nuts, fragrant grasses and pungent buds eaten in the freedom of the wilderness. In short the true, the genuinely patriotic Thanksgiving roast is the body of a wild turkey. The great day comes just at the time when spring-hatched birds are coming to maturity, plump and tender, juicy as ripe fruit and flavored by the subtlest processes of nature to a delicate nicety which no cook may hope to imitate. The epicure knows this flavor and values it, and the wild turkey should bring twice the price of a domestic one in the market. "Lord Lorne's attempt to acclimatize the wild turkey has so far proved successful, and there seems no reason why it should not be bred throughout the country and take its place on the menu side by side with the wild duck."

**TURTLE**—Half a dozen great turtles in the United States alone give their tender flesh to epicures, and minister to aldermanic amptitude. These all come out of the sea, and the chief of them is he of the green tint. A salt water turtle, weighing 500 pounds, was captured at the mouth of the Spurwink River, in Maine, by two brothers named Jordan. It seems the monster got entangled in the nets these men had set, and they fastened to the turtle and towed him ashore. Monday they sold him to Captain Howard Knowlton, for his garden at Peaks' Island. The price paid for the turtle was \$50. So broad is the shell of this monster, that four boys found room to stand thereon, and the turtle was strong enough to crawl along with this load. **A MAMMOTH TURTLE**—While the steamer *Flora Temple*, of Jacksonville, Fla., was cruising near the snapper banks yesterday about fifteen miles off shore, Captain Montcalm Broward observed an immense black object floating on the surface of the water. Upon approaching it he discovered that it was an immense turtle of some sort, which was lazily sleeping on the surface of the water. The captain secured a harpoon, and when near enough he dexterously threw the weapon and succeeded in fixing it firmly in the back of the monster. It was found impossible to raise this mountain of flesh to the deck of the boat, so the captain attached a hawser to the harpoon and, taking it in tow, brought it up to the city, arriving at Decottes' woodyard about 5 o'clock, when the huge object was hauled out upon the shore, where its great size soon attracted a large crowd that gazed with wonder upon the strange visitor. The weight of the captain's catch was variously estimated to be from 1000 to 1,500 pounds. It measured across the anterior limbs fully eight feet two inches, was seven feet two inches from the end of the nose to the tip of the tail, and perhaps

## TUR

eight feet in circumference. The captain called his catch a tortoise, but the *News-Herald* man identified it as a peculiarly splendid specimen of the trunk or leathery turtle (*Sphargis coriacea*.) This great sea denizen inhabits the Gulf stream along the Atlantic shores and elsewhere. It does not have a shell, but is covered with a leathery skin, with seven longitudinal ridges. It is the largest of the turtle tribe. **TURTLE STEAKS**—The flesh of the turtle is called "Barbadoes beef" in the West Indies. Turtle steaks and turtle fins are favorite breakfast dishes in the Antilles. **TURTLE PIE**—There are many ways of cooking turtles in the Bahamas, where they are largely caught. The favorite plan is to make the bulk of the flesh into a kind of hash, well doctored with port and other wines, and then to serve it up in the shell covered with crust, so that it looks like a kind of meat pie. This is called "baked turtle." **TURTLE SOUP THICK OR LICE**—The turtle is killed by cutting off the head, hung up by the hind flippers to bleed, then lowered into a kettle of boiling water and parboiled, if convenient, but if not, can be cut up raw, as it is done in the New Orleans fish markets, where turtle is sold in cuts as wanted like any other raw meat. The object of scalding is to make the shell separate easily and allow the outer skin to be peeled from the fins. When opened the gall bladder and intestines are taken out and thrown away, the eggs, if any, saved, and the green fat found under the shells is saved separately, the turtle meat allowed for the soup, and the chopped up shells are then put on to boil in water. In another boiler is made the same preparation as for *espagnole* (which see) of fried slices of ham, veal, onions and other vegetables, spices and herbs in butter, brown *roux* added, and veal or beef broth and the turtle broth, which are all then allowed to simmer slowly for some time; the *roux* of butter and flour having thickened the soup, it requires stirring and care to prevent burning. The remaining operation is to strain the soup from the mixed ingredients, skim off the fat, put in the turtle meat cut in pieces, the turtle eggs, pieces of green fat, salt and cayenne, and madeira or sherry, and little lemon juice. **TURTLE SOUP A LA CREOLE**—The only difference from the foregoing is the addition to the boiling soup before straining of a large proportion of stewed tomatoes, about one-fourth of the whole being tomatoes before straining. **TURTLE SOUP CLEAR**—Is made in both of the ways just described, with the single difference that no *roux* or other thickening is put in. Cooks, who have a regular daily habit of making a clear consommé of some kind for dinner, often proceed in a different way by seasoning and clarifying the turtle broth and coloring it, adding the cubes of turtle meat at the moment of serving. Turtle soup is not nearly so well known or highly thought of in the United States as in England, where it is and has long been almost a national dish, notwithstanding their turtles have to

## TUR

be imported from this side. This is on record since So years ago: *Turtle Soup*—"The usual allowance at a turtle feast is six pounds live weight per head; at the Spanish dinner, at the City of London Tavern, August, 1808, 400 guests attended, and 2,500 lbs. of turtle were consumed." Appropos of turtle soup and turtle steak, it was Artemus Ward who said: "As for me, give me turtle or give me death. What is life without turtle? Nothing! What is turtle without life? Nothings still!"

**TURTLE EGGS**—Turtle eggs are held in great esteem wherever obtainable, equally by Europeans as by others. These eggs have a very soft shell, and are about the size of ordinary pigeon's eggs. The mother turtles lay three or four times a year, at the rate of from 140 to 200 eggs each laying. The Orinoco and Amazon Indians obtain from these eggs a kind of clear sweet oil, which they use in much the same way as we do butter. In the month of February, when the high waters of the Orinoco have receded, millions of turtles come on shore to deposit their eggs, which they always carefully cover over with the sand. The natives about the mouth of the mighty River Amazon alone, gather some 5,000 jars of the oil, and each jar of oil represents the product of over 5,000 of these turtle eggs.

## W.

**WOODCOCK**—Small game-bird larger than a snipe; in season 5 months, September to January inclusive. SAID ABOUT WOODCOCK—"There is nothing in the whole *mundus edibilis* equal to a well-prepared woodcock. To no other bird do we pay such homage: is is the glory of the *gourmet*, the pride of the cook, the well-beloved of all men; the height of gustatory excitement, the consummation of all luxury; succulent as regards its flesh, volatile touching its elements, and perfect respecting its flavor."—"The *gourmets* have a way of knowing when the flesh of the woodcock is arrived at the degree of flavor required to be sought after. The bird is suspended by the beam-feather of the middle of its tail; when the body gets loose and full, then is the time to eat it."—"In one respect the woodcock (and also his cousin, the snipe) is more honored than any other kind of game. He is never drawn; every morsel of him is eaten, to the last entrail. The choicest bit is the head, the thigh is finer, the trail is considered superlative. The usual way of roasting this bird is to tie him up in slices of bacon, and hang him, tail downwards, before the fire. Under each bird is put a slice of bread, toasted a delicate brown, and on to this the trail drops. Sometimes when half done the trail is removed, mixed with bacon fat, chopped shallot and crumbs of bread, salt and pepper, and then spread upon the toast, which is returned to the pan until the bird is finished. Lemon

## WOO

in slices is served with him."—"It is a bad plan to 'spit' any small birds; they should be tied to a spit, and, if roasted in the contrivance which the French call a *rotissaire*, they stand a better chance of being artistically roasted."—"When roasted, woodcocks and snipes ought to be, as the French term it, *vert-cuit*—that is to say, underdone. As is well known, they must not be drawn; the gizzard alone is extracted from the inside with the point of a skewer, inserted in the side of the bird, which is then trussed in the usual way, and wrapped up in a slice of fat bacon tied round with string. Fifteen minutes is sufficient time to roast a woodcock before a brisk fire." **WOODCOCK PIE**—"Snipes and woodcocks are plentiful in Ireland. In accordance with ancient custom, the Lord-Lieutenant sends every year as a Christmas present to the Queen a monster game-pie composed of 2 doz. woodcocks and about 100 snipes. The birds are boned and stuffed with a *farce* of



WOODCOCK—BECASSE.

*foie gras aux truffes*, and the crust is elaborately decorated with appropriate designs." **WOODCOCK COOKED IN AMERICAN STYLE**—Picked and singed while fresh; head skinned; eyes, crops, and gizzards removed; trail chopped with two chicken livers, salt, pepper, butter, and spread on slices of toast. Birds with slices of fat pork on breasts roasted in hot oven 15 minutes, toast with trail set in oven 5 minutes; woodcocks served on the toast. **BECASSES A LA PIEMONTAISE**—Woodcocks roasted, served with game sauce and truffles. **FILETS DE BECASSES A LA TALLEYRAND**—Breasts of woodcocks in form of a crown, with *croustons* of fried bread spread on the trails, same size as the fillets; fumet sauce with truffles in the center. **FILETS DE BECASSES A LA LUCULLUS**—Breasts of woodcocks coated with forcemeat and served on a border of toasted bread, with a thick purée of woodcocks piled in the center, and game sauce around. **SALMIS DE BECASSES**—Woodcocks are the best of all birds for a salmis. **TURBAN DE BECASSES AUX CHAMPIGNONS**—The birds cut in halves and dished in crown shape with game sauce and mushrooms. **CHAUDFROID DE BECASSES**—Woodcocks roasted, cut in joints, coated by dipping in thick chaudfroid of game sauce; decorated; eaten cold.

APPENDIX TO THE STEWARD'S HANDBOOK.

---

# HOW TO FOLD NAPKINS.

ABUNDANTLY ILLUSTRATED

With Many Handsome Styles and Diagrams  
Which Show How it is Done.

---

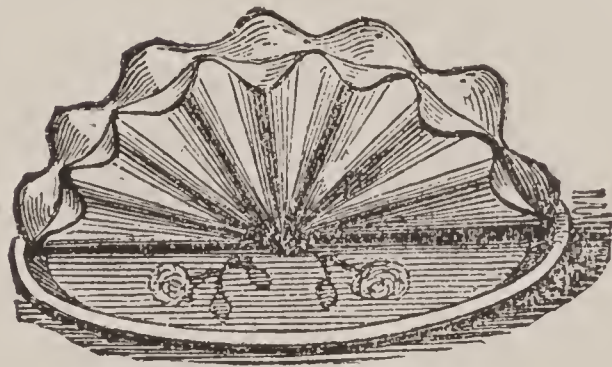

CHICAGO, ILL.  
JESSUP WHITEHEAD,  
PUBLISHER HOTEL COOK BOOKS,  
183 NORTH PEORIA STREET.

1888.



JOHN ANDERSON & CO.,  
Printers,  
183—187 N. Peoria St., Chicago, Ill.



# CONTENTS.

---

	PAGE.
Introduction .....	5
The Escutcheon .....	7
The Chestnut Pocket .....	8
The Shield .....	8
The Mitre .....	8
The Cornucopia .....	9
The Crown .....	9
The Scroll .....	10
The Slippers .....	11
The Cocked Hat, or Boat .....	11
Another Boat .....	12
The Hamburgh Drum .....	13
The Heraldic Rose and Star .....	14
The Minarettes .....	14
The Shell .....	15
The Fan .....	15
The Rosette Fan .....	16
The Victoria Regia .....	16
The Swan .....	16
Lorgnettes .....	17
The Pyramid .....	17
The Fleur-de-Lys .....	18
The Archbishop's, or Double Mitre .....	18
The Bread Basket .....	19
The Flower Basket .....	20
The Imperial Crown .....	20
The Double Horn of Plenty .....	21
The Colonne de Triomphe .....	21
The Tulip .....	22
The Bridal Serviette .....	23
The Prince of Wales's Feather .....	24
The Arrow Head .....	25
The Menu Holder .....	25
Mercury's Cap .....	26
The Sail Boat .....	27
Hotel Napkin Folding .....	28



## INTRODUCTION.

---

The folding of the serviette may often be made complimentary to the guest. Not only does "the Bridal" point out its special application; but "the Crown," "the Prince of Wales's Feather," and "the Mitre." "The Boat" is appropriate when a naval chief is the honored guest; "the Colonne de Triomphe," for the entertainment of a hero fresh from a new victory; "the Victoria Regia" for a distinguished botanist, and "the Fan" for a reigning belle, so may "the Cocked Hat" be made available when a military hero is entertained, and "the Heraldic Rose" for a guest whose hobby is with things that appertain to the board.

In the days of our forefathers the quantity and quality of the viands were thought of more consideration than the appointments of the table. Provided the hospitable board groaned beneath the combined weight of substantial food and a silver service, the banquet was pronounced magnificent. Now we have changed all that. The contents of the dishes have become secondary in importance to the decorations. The eye must be feasted as well as the palate. Heavy silver ornaments have given place, or at least are associated with, vases of crystal and abundance of flowers, with scent fountains and the choice fruit selected for dessert. The folding of the serviette, or table napkin, was always a matter of attention; at the present moment it is doubly so, when the luxury of table decorations are carried to such an extent that ingenuity is constantly on the strain, not only to produce every possible variety of *cartes de menu*, but even fanciful stands to hold them or the guests' name-cards in a prominent position. The parlor maid, or the waiter, or the dainty mistress of the house herself, must look to their laurels in the matter of folding serviettes, or the other showy trifles placed on the board will cast the attractions of the table napkin completely into the shade. To fold them well in the more elaborate styles, it is necessary that they should be made of very fine, but rather stout damask, starched more or less, quite fresh and nearly new. Old damask, that is soft, will not take the more elaborate forms. Each serviette, previous to folding it, should be laid on the ironing-board damped with (raw) starch, smoothed with a hot iron, and immediately folded whilst crisp and steaming. It not only folds better, but preserves the form longer by such means; and unless this is attended to designs like "the Fan," "the Victoria Regia," "the Bridal," and "the Colonne de Triomphe," could not effectually be made. "The Boat" and "the Basket" also require very stiff serviettes. The serviettes must be exactly square, and pains taken to make the sides perfectly even and true.





## FOLDING SERVIETTES.

## THE ESCUTCHEON.

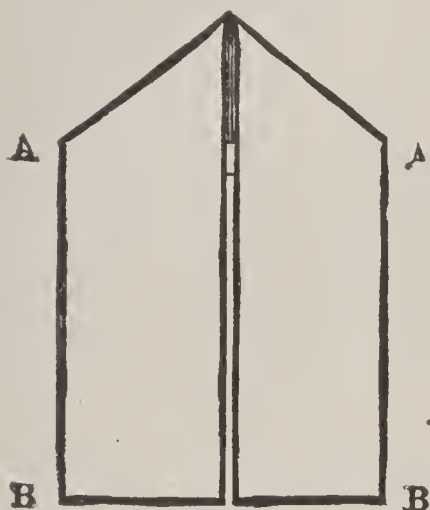

Fig. 1.

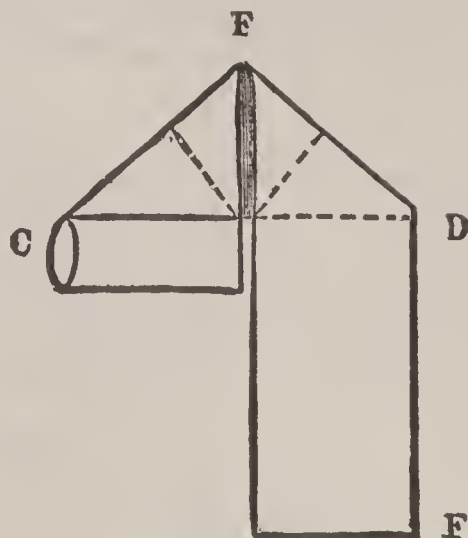

Fig. 2.

This is one of the easiest methods possible of ornamentally folding a serviette, and we recommend a novice to commence with it. Indeed, we have arranged the folding as progressively as possible. Although it will sit more crisp and fresh in appearance if made with a fine new well starched material, the Escutcheon can be made very well with old or even crumpled damask, though, of course, serviettes should always be scrupulously clean and smooth. First, fold the serviette in half lengthwise; and then fold it in half again lengthwise, keeping the edges to the lower end, which comes where in the diagram A A and B B are marked (see fig. 1). It is necessary to be always very precise in making the folds, bringing the edges and corners exactly to meet, a rule which applies to all the designs; but without strict attention to which, the more elaborate patterns cannot be represented.

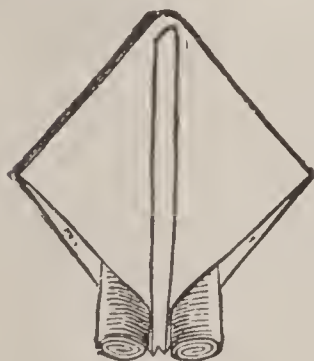

Fig. 3.

Now turn over each end of the serviette (which you have already folded in four), in the manner shown in fig. 1, creasing it quite flat. Then take one of the ends and roll it up in the manner shown in fig. 2, from C to D. Take the other end, E, and roll it in the same way. It is



Fig. 4.

to be observed that these rolls are brought exactly to meet (not to overlap) the triangle formed at the top. It is, however, necessary to remark that the napkin is to be rolled in the reverse way from that apparent in the illustration; that is, to be rolled *under* and not *over*, a difference which must not be neglected. Keep the rolls one in each hand, and with a twist of the wrist bring over the roll C, to the point F (causing the fold marked by the dotted line), and with a twist of the other wrist bring the roll up to the same point to match it. Then lay it flat on the table, the rolls underneath (see fig. 3), and keeping them down with the hand, raise the other part and shape it as shown in fig. 4, and slip the dinner roll in the hollow at the back.

## THE CHESTNUT POCKET.

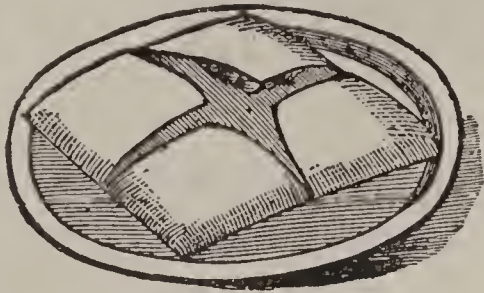

Fig. 1.

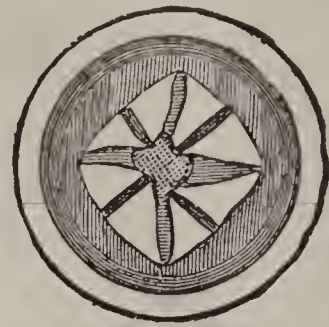

Fig. 2.

Fold the serviette in half both ways, and open it again. Bring all the corners to the centre. Turn it over and again bring all the corners to the centre. Turn it back again and slip the chestnuts in the four pockets to be observed in fig. 1.

Fig. 2, the Pocket Serviette, is made in the same way; but the corners are brought three times, instead of twice, to the centre, turning it each time (see fig. 2).

## THE SHIELD.

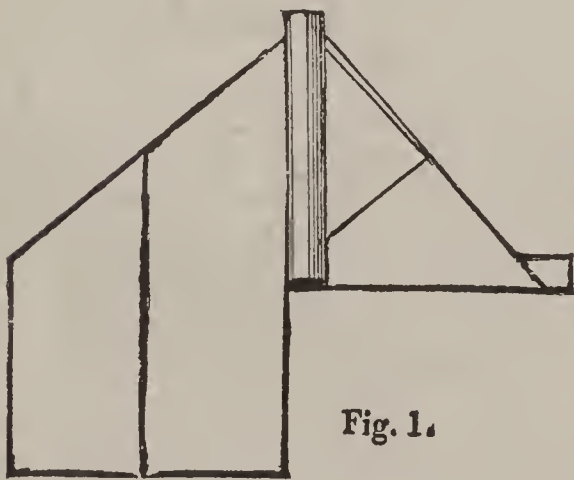

Fig. 1.



Fig. 2.

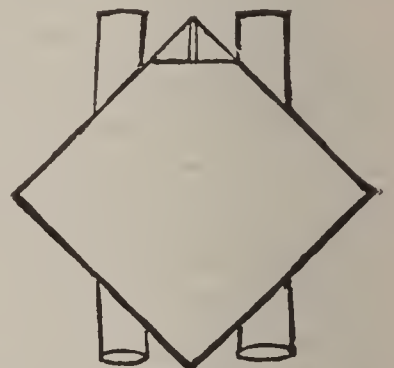

Fig. 3.

The Shield is almost identical with the Escutcheon; there is, however, a slight difference, which forms a little variety and practice in the art of napkin-folding.



Fig. 4:  
and resemble figure 4.

First form fig. 1, as for the Escutcheon. Next roll up the two ends in the manner shown in fig. 2; that is, make the rolls outwardly, not under as in the previous direction. The serviette will now resemble fig. 3. Then set it into form, and place the bread inside. The face of it will stand perfectly upright

## THE MITRE.

The Mitre is a well-known device, and one which always looks effective. It is not unlike the Crown. Fold the damask in half, and turn down the two corners to meet at both ends, in the manner shown in fig. 1, taking care to let them meet very exactly and not overlap. Fold it in half at the line A to B, fig. 1, to ascertain the centre. Open this last fold again and bring the two points to the centre like fig. 2. Fold these together at the dotted line with the points *out-*

side, let down one of these corners again, and turn in the two points A and B also, to make a triangle uniform with the others: it will now resemble fig. 3. Turn the

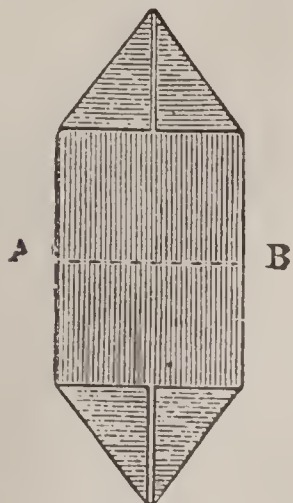

Fig. 1.

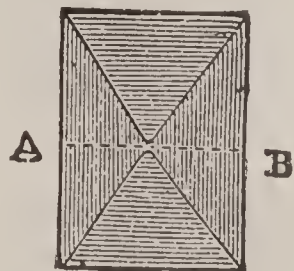

Fig. 2.



Fig. 3.

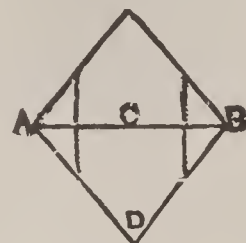

Fig. 4.

serviette over; let down the point on that side: it will then resemble fig. 4. Turn in the corners A and B, by the line marked. Turn up the point D to its former

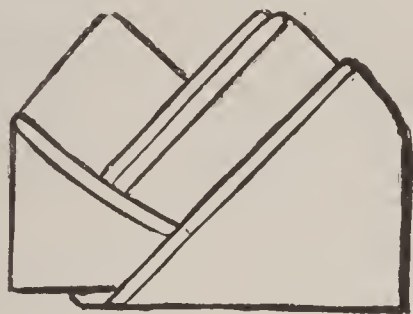

Fig. 5.

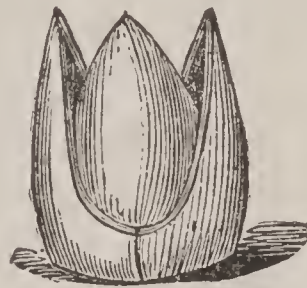

Fig. 6.

position: it will now resemble fig. 5. Slip the hand inside the hollow to be found at the broad end, and shape it like a cap, and the Mitre is complete.

### THE CORNUCOPIA.

Cornucopias are easily folded, and very effective down a long dinner table, with a single scarlet geranium flower at the apex of each. Halve the serviette lengthways; turn down the corners at the two ends to meet in the centre and form a triangle, like fig. 4, in the Crown.



Fig. 1.



Fig. 2.

Take the corners at the base and bring them to the apex, like fig. 1. Then double it together with folds inside: it will now appear like fig. 2. At the side marked A, there are three folds. Set it upright over the dinner roll, with two of these folds one side and one on the other. Shape it nicely, keeping the space from B to C close.

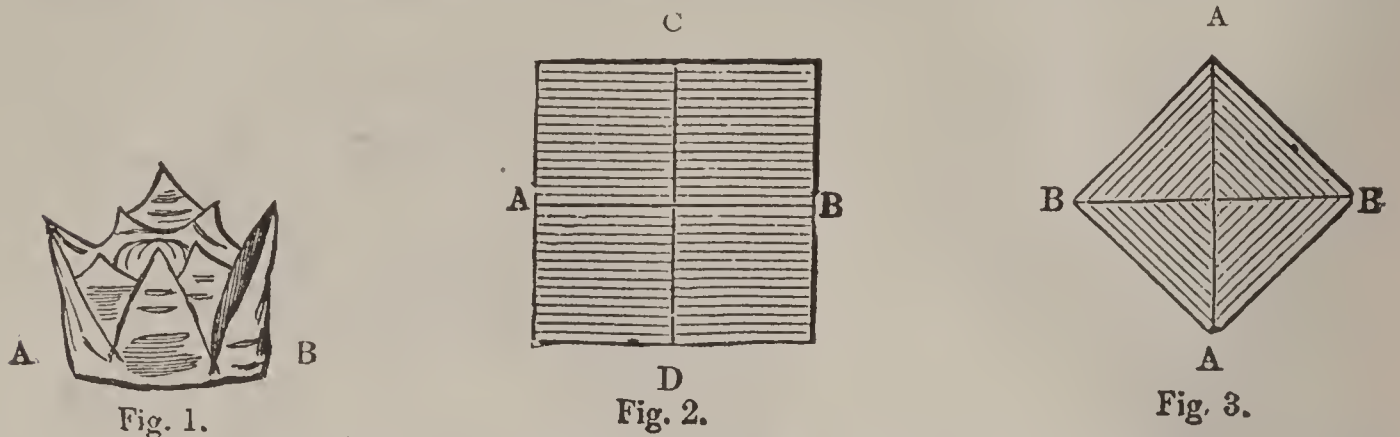

Fig. 3.

### THE CROWN.

This is a handsome design, and is one which requires very well starched damask. The bread is placed inside, underneath the crown. Now that flowers are so much used, nothing could have a more charming effect than a slight wreath of flowers round the base of it, at the part marked A to B, in fig. 1. Fig. 2 represents the serviette laid on the table. Fold it exactly in half from A to B, open

and fold the reverse way, from C to D. Open it again. These creases are merely made to ascertain the true centre. As it lies, turn all the points to the centre,



and crease down in the manner observed in fig. 3, which forms a diamond. Take the four corners of the diamond and fold them to the centre again. The serviette

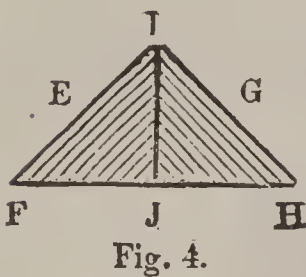

will still preserve the shape shown in diagram fig. 3, but be smaller in size. Bring the top, A, to the right hand, B, and the left hand, B, to the other, A; it will now resemble fig. 4. Fold down the corners, E F and G H, parallel to the line I J; it will now resemble fig. 5. Put the hand inside it at the broad end, and shape

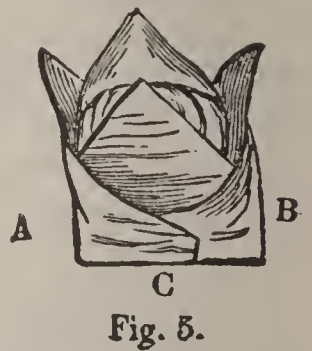

it like a cap, over the hand, folding one end into the other as shown at C, in fig. 5. The stiffness of the damask should be sufficient to keep these last folds in place; the corner fold should just be turned one corner within the other as an envelope, and pinched, to secure its remaining firm.

THE SCROLL.

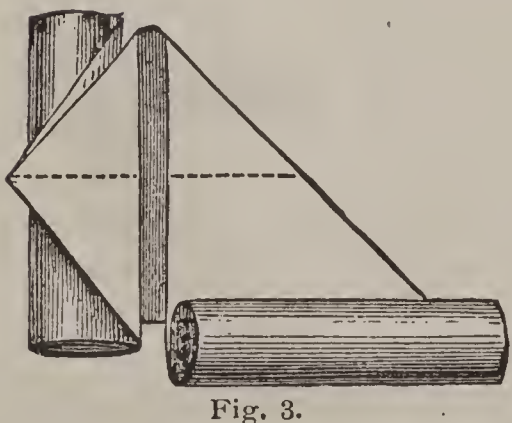
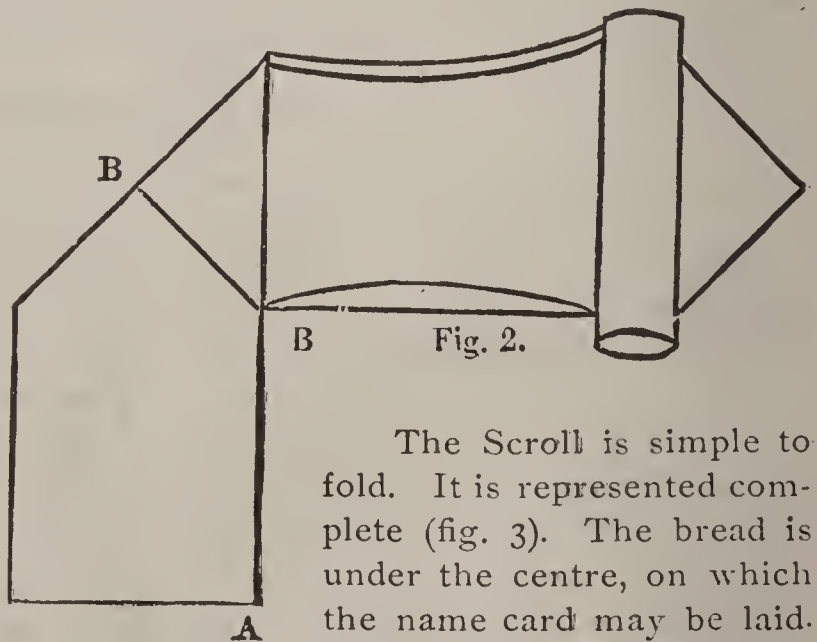
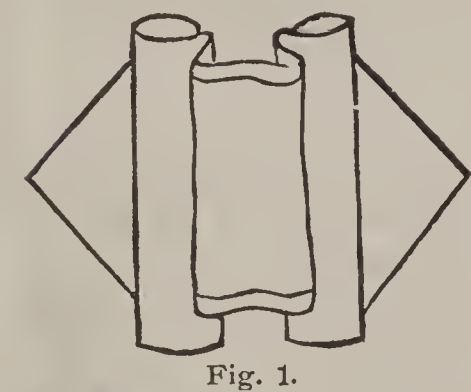

The Scroll is simple to fold. It is represented complete (fig. 3). The bread is under the centre, on which the name card may be laid.

It does not require to be stiff. First fold the serviette four times lengthways. Fold down one end in the manner shown at A, in fig. 2. Then fold the end A completely across, forming the line, B B. Roll

up the end A, and produce the fig. 3. Treat the other side in the same way. Fig. 3 illustrates the process. The space in the middle, A, fig. 1, is closed over the bread.

## THE SLIPPERS.

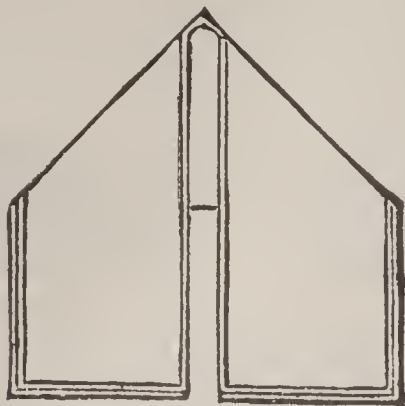

Fig. 1.

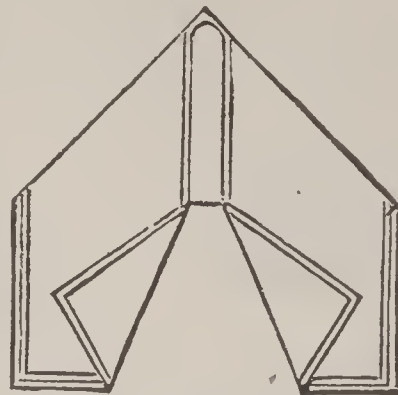

FIG. 2.

The Slippers are very easy to make. Double the serviette four times lengthways. Then fold like fig. 1. The ends are simply rolled, taking the corners ... the method shown in fig. 2; bringing them over as shown in fig. 3,

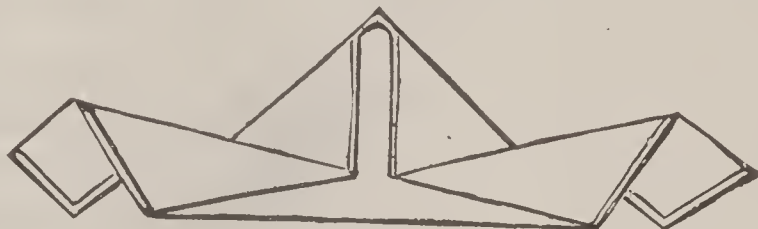

FIG. 3.

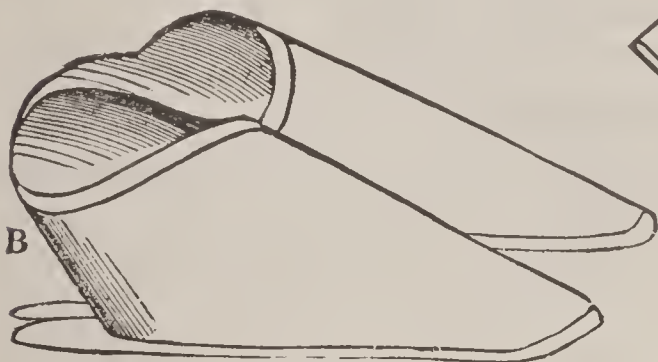

Fig. 4.

and with another turn forming the Slippers (fig. 4). Secure the point at A, with the left hand, whilst rolling up the other side; and then hold both points together with the left hand and place the right in

the top of the Slippers, setting them over the dinner roll, which should be placed underneath at B, fig. 4; and the Slippers pinched close together at the top over it. A few flowers in the hollows of the folds is a pretty addition.

## THE COCKED HAT, OR BOAT.

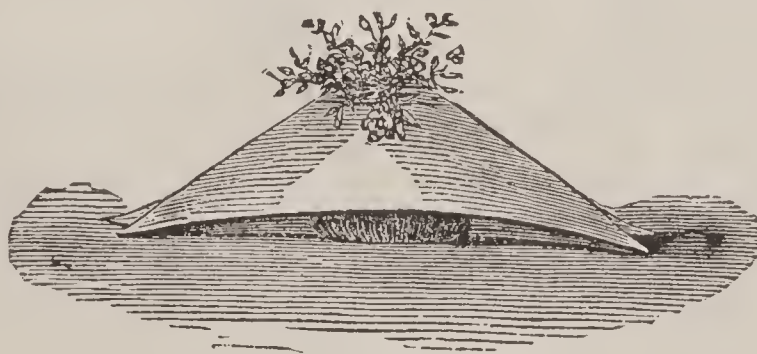

Fig. 6.



Fig. 1.



Fig. 2.

Fold a serviette in half lengthways (see fig. 1), then in half again (fig. 2). Fold it lengthways again, with the edges inside, in the way shown in fig. 3. Fold it in half lengthways at the dotted line with the edges outside. Turn down the corners in the manner explained by fig. 4, both sides alike; it now resembles fig. 5. Turn in the superfluous end C, shown in fig. 4, inside the hat: this makes it resemble fig. 6. Shape it with the hand and slip it over the dinner bread. If the edges are left outside in folding (fig. 3), when finished, a space will be offered at the top wherein a few flowers may be

placed. A Boat may also be folded by this diagram by reversing its position on the plate. A still better way to make the Boat is to double a serviette in half lengthways, and again the reverse way. Fold the two edges to the centre: this makes an oblong. Turn it over on the other side. Turn two of the corners to

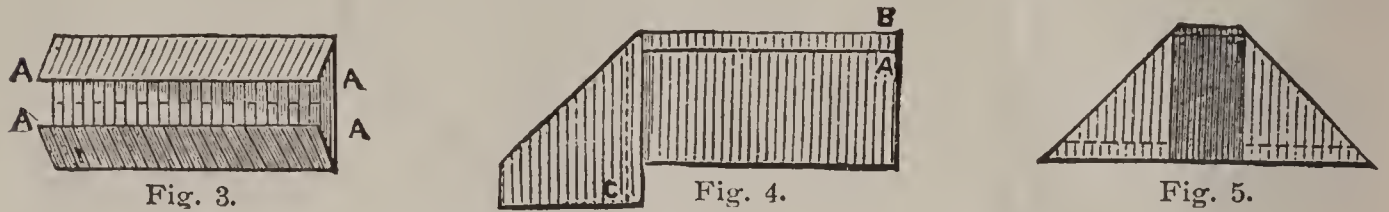

meet in the centre; must not be opposite corners, but both at the right end. Turn the two left end corners half to the middle. Iron down. Then fold the whole in half lengthways, having the corners inside. This completes the Boat. Put the bread underneath.

ANOTHER BOAT.

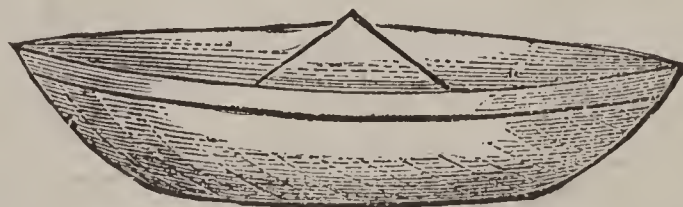

The Boat is exceedingly pretty, especially if freighted with a few flowers. The serviette should be well starched to sit firm and sharp, and must be an exact square. First fold it in half like a shawl. Next take the corner A (fig. 1), and bring it to C. Turn over the serviette on the other side. Take the corner B, and bring it to C in the same way, but on the other side: this forms fig. 2. Fold

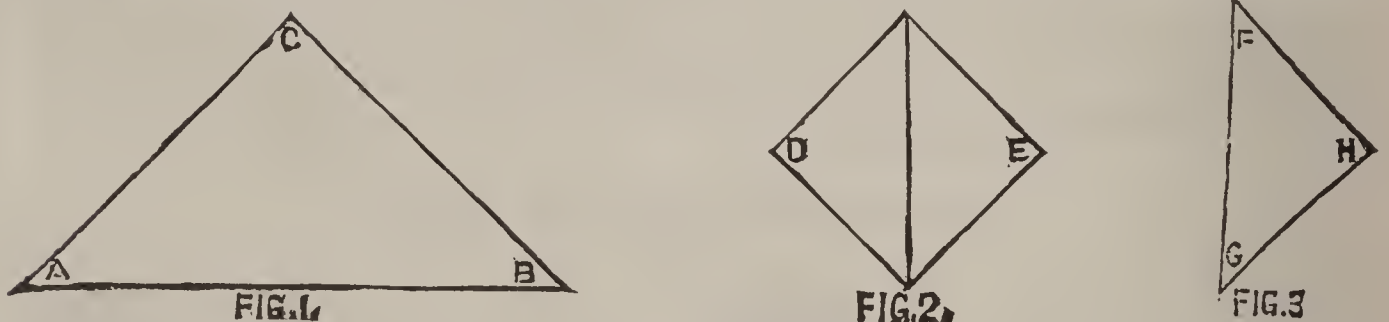
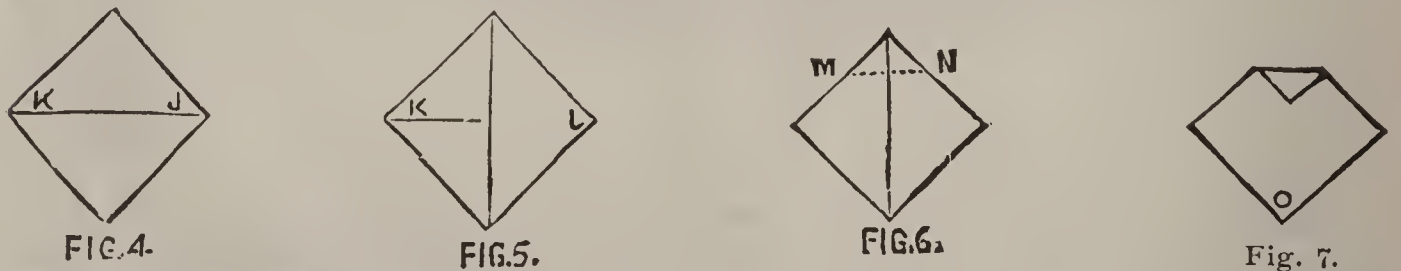

fig. 2 in half by the line in the centre, bringing D to E, and forming fig. 3. Fold the point F to H. Turn over the serviette and fold G to H, on the other side: this produces fig. 4. Fold the half of the end J to K, producing fig. 5. Fold L to K, on the other side. These folds must be so made as to leave the upper part of the serviette, which will now again open and look like fig. 3, from F to G.



Slip the hand inside here, round it open a little, and so bring F to meet G, making it flat the reverse way: this is represented by fig. 6. Turn down the whole point M to N, on the thinnest side, like fig. 7. Slip in the thumbs at the opening at O in fig. 7, and holding the last fold firmly down; dexterously turning the Boat inside out: the inside fold resembles a capital A. Pinch the sides of the A the

other way, making it an A again; and drawing out the Boat lengthways. Shape it a little with the hand. The bread may be slipped under the centre, A, or cabin of the Boat, provided it is not too large. A pretty addition to this would be to attach the *carte de menu*, by the means of a Chinese ribbon, to a chip, spill, or slender stick, and fix it in the Boat as a sail. The name card may also be attached to resemble an additional sail.

THE HAMBURG DRUM.

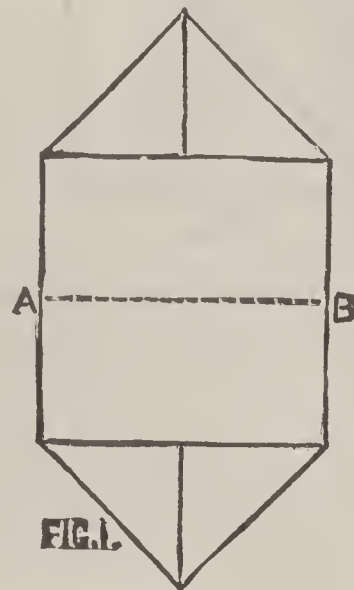
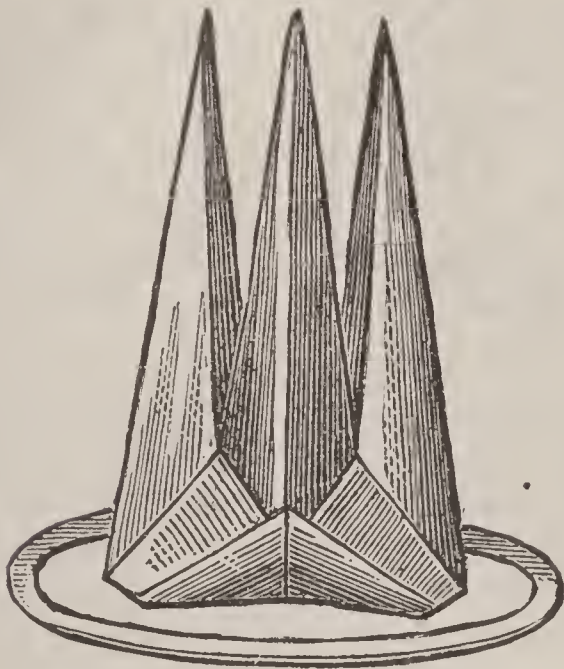

The first three folds are made like those of the Mitre; namely, fold the serviette in half lengthways. Turn down the corners like fig. 1, fold it in half across the centre, inwards, from A to B, keeping the corners inside. It will now

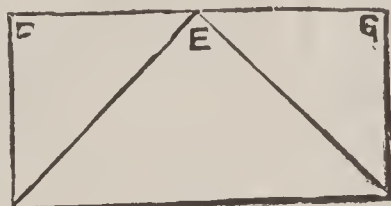

resemble fig. 2. Fold it again from C to D, into the shape of fig. 3. Let down the point E; turn down the corners F and G, to make a triangle uniform with the others: thus you have fig. 4. Let down the corner H, as shown in fig. 5: this

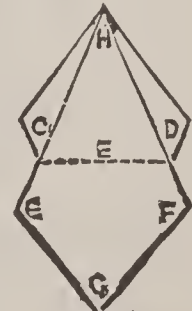
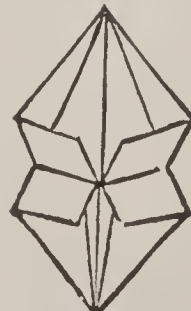
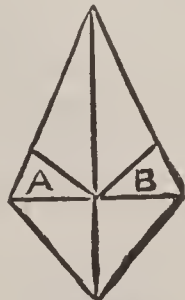
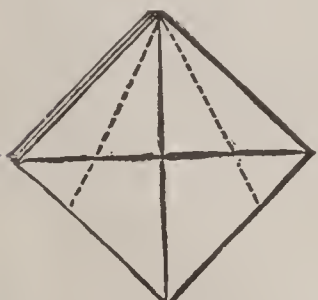

corner must be the one that has the selvage on the lower corner. Make the fold by the dotted line in fig. 5: this produces fig. 6. Take the upper fold at A and B in the same diagram, open it back and crease it down to resemble fig. 7; turn the

napkin over. You now have fig. 8. Fold over the edges C and D to E, to match the folds on the other side. Turn up the napkin again; turn up the point C, and bring the corners, E and F, together likewise. Slip the hand into the hollow at the base, as you did for the Mitre; and place over the bread.

### THE HERALDIC ROSE AND STAR.

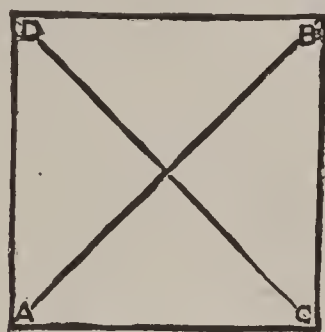

FIG. 1.

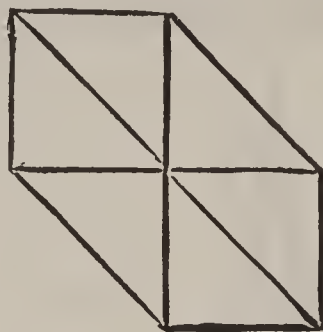

FIG. 2.

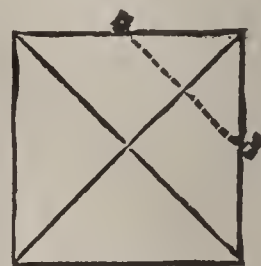

FIG. 3.

Spread a serviette, full size, flat on the table. It must be a perfect square, exact at the corners. Bring the four corners exactly to the centre, in the way described in fig. 1. Take the corners A and B, and without turning the serviette, again bring them to the centre, as shown in fig. 2. Bring C and D likewise to the centre: this forms fig. 3. Take one corner and turn it *under* (not over as before) by the dotted line *e* to *f*; turn under the other three the same way. Then again bring all the four corners to the centre, on the upper side, as in fig. 2.

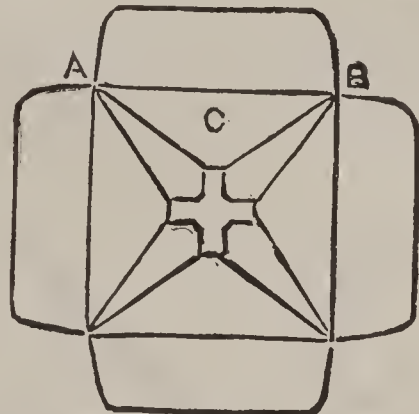

FIG. 4.

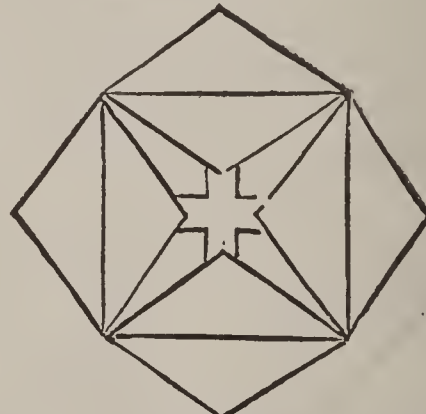

FIG. 5.

Afterwards repeat turning all the corners under, as in fig. 3. Then once more repeat fig. 2, and bring the remaining corners to the centre, uppermost. Press the folds firmly down. Then, one at a time, turn the corners half back, shaping them like little pockets, by slipping the fingers in at C (A to B, fig. 4), and forming the corners out square. This makes the Rose. Or by turning it down in the same way, without squaring out the corners, the Star, fig. 5, is made. Open up the eight petals, to be found in the centre, and fit in the dinner roll.

### THE MINARETTES.

The Minarettes is a design expressly originated for the present work. It requires to be well stiffened. Fold the napkin in half. Turn down the corners as in fig. 1 of the Mitre. Fold in half and turn in the corners till you have an exact triangle as in the Mitre (see fig. 1). Then let down the outer side of the triangle. Fold the corners at both sides by the dotted lines, A and B (fig. 1).



Take the outer pieces, C and D, and fold back so as to have two points alike. Fold the lower end to match; halve it, and you will now have fig. 2. Fold up at

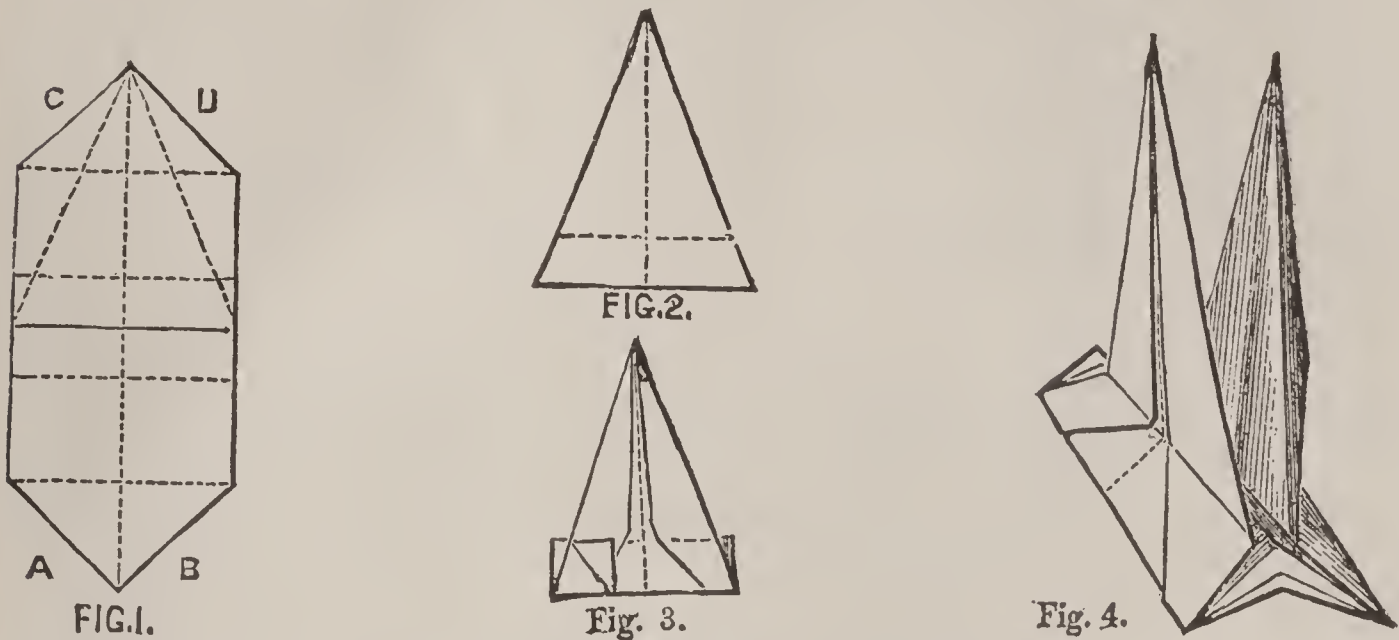

the dotted line. Pass the fold inside like fig. 3. Bend over the corners like fig. 4, and place the Minarettes over the roll.

**THE SHELL.**

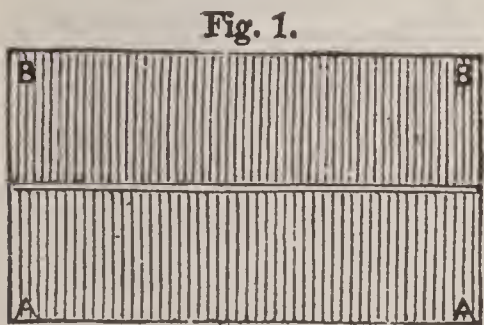

The Shell requires a very stiff serviette. Fold the two edges together in the centre, lengthways,



as shown in fig. 1. Fold in half down the centre, also lengthways, leaving the edges outside. Then crimp evenly in the manner shown in fig. 2. Open up the top end, and turn down the edges each way, as they appear in fig. 3. Keep the lower ends together like a

fan. If well done, it can be balanced on the plate by the ends, in the manner illustrated by fig. 4.

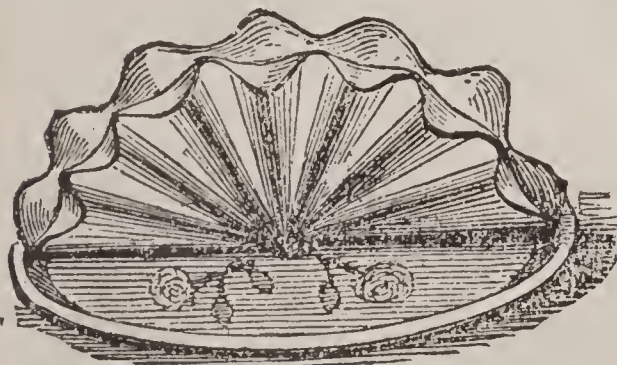

Fig. 4.



Fig. 5.

**THE FAN.**

The fan is made precisely like the

Shell, only the edges are not turned down; but in folding, at first, are kept inside. The fan is placed in a glass, in the way shown in fig. 5.

It is, also, sometimes folded again before crimping three parts up. This forms a double Fan, and the lower one should be pulled out a little by the fingers.

### THE ROSETTE FAN.

The Rosette Fan is very handsome and uncommon, but difficult to make, requiring very nice manipulation. First fold the serviette in half, lengthways, the edges downward. As it lays on the table, make it into three equal folds, lengthways. Then take the upper fold between the finger and thumb, lengthways, and the lower fold between the second and third fingers of each hand. Bring the lower fold up to within an inch and a half of the fold left, and the one between the finger and thumb to within an inch and a half of that. The hemmed edges ought to be an inch and a half below the last of the three plaits you have now formed. Press them well down. Crimp as for the Rosette. Hold what would be the handle of the Fan well in the left hand, and keep it all close together. Insert right through the upper fold or plait the handle of a silver fork, the flat way, and when right through, turn it, rounding out the plait like a bullionné on a lady's dress. Treat the other two plaits in the same way. Then put the handle end firmly in a glass and let the top spread out. The effect is excellent.

### THE VICTORIA REGIA.

This spirited design is difficult to accomplish, and requires to be very stiff indeed. Fold the serviette in half twice,

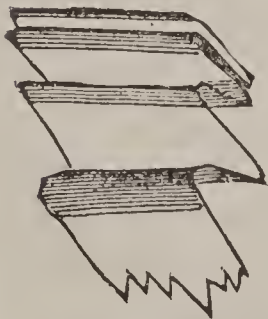

Fig. 1.

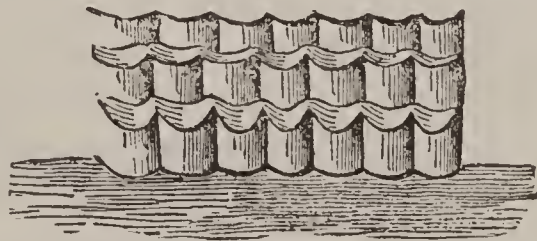

Fig. 2.



Fig. 3.

lengthways, keeping the hems to the edge. Then plait it as the Shell was plaited, in the way shown in fig. 1. The number of petals will depend on the number of folds, which should be twice as many as were made for the Shell, the width being only half as much. Keep the folds as close together as possible, and begin forming the petals by drawing back the first hem, as the edge of the Shell was done. Proceed to turn down the next fold and make another round of petals to meet the first ones, and finish by making the last hem fold in the same way (fig. 2). Set it round by bringing the two edges of the serviette together. It is not at all easy to set the petals well. The bread is not to be placed in or under it; but a single flower, such as a rose, may very properly be slipped into the heart. Fig. 3 represents the Victoria Regia, which should be placed in the centre of the plate.

### THE SWAN.

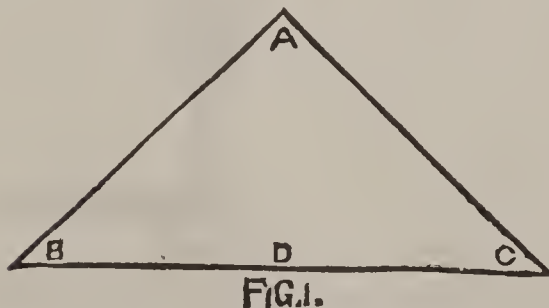

FIG. 1.

The Swan is a very simple fold, yet one requiring some knack to produce. The serviette should be very stiff. Form a triangle by folding it in half. Hold the point, A, between the teeth; take C and B in each hand. Hold it tight across the chest, so that from A to D it is strained tight against you. Roll up the ends B and C very tight, one in each hand, in the manner shown in fig. 2. The reason it is held tight across the chest is to keep it plain at E; otherwise it would curl up to the top. Now bring the points B and C together (fig. 2). Bend over the point

A and shape the twisted pieces so as to give the appearance of a Swan. Our illustration gives but a rough notion of it, as it is not easy to delineate well on paper, and at the same time show the way of bending it. With a little manipula-

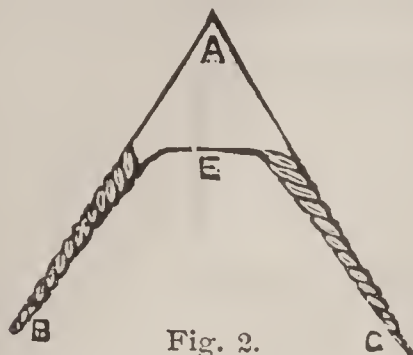

Fig. 2.



FIG 3.

tion, a very good imitation of a Swan may be produced. The centre piece is the head and neck; the twisted portions represent the outline of the breast, body and the legs.

### LORGNETTES.

Lorgnettes are very easy indeed, and are a neat design. Fold the serviette in half lengthways. Fold back an inch, or an inch and a half, at the double end,

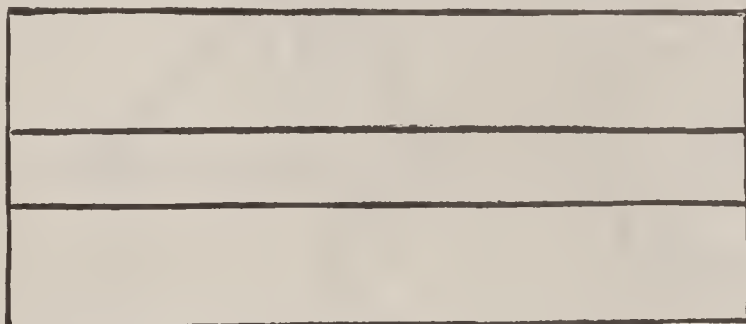

Fig. 1.

and bring it to the centre, in the same way observable in fig. 1. Turn it over on the other side and roll both ends, one at a time, to the centre; taking care to press in with the fingers, as it is rolled, the tendency to bag up; so as to keep it smooth

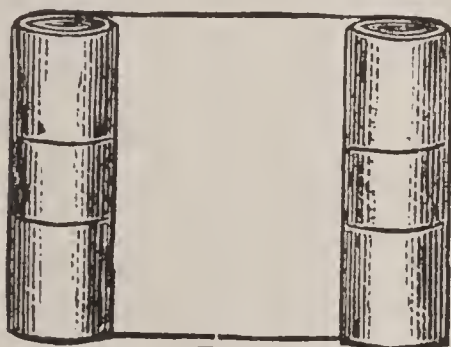

FIG 2.

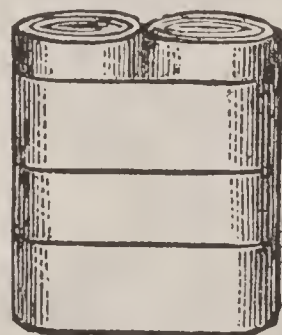

FIG 3.

outside, and the centre band tight. Stand it upright. The Lorgnettes do not inclose the bread.

### THE PYRAMID.

The Pyramid, provided the napkin is very stiff and fine, is easily made. Double it in half one side within an inch of the other, so that it may be more slender towards the point. Fold it in seven the narrow way, like fig. 3, in the shell. Press these folds down with an iron; then crimp them across with a paper knife, folding it in and out the width of the knife. Lastly, join it round like a pyramid, and stand it upright over the bread. For a bride, or a distinguished guest, slender wreaths of flowers may be placed all round in every crimping.

### THE FLEUR-DE-LYS.

The Fleur-de-Lys should be folded with very stiff damask, a little damp, and fresh ironed; but may be made with a small light damask, without starch, by

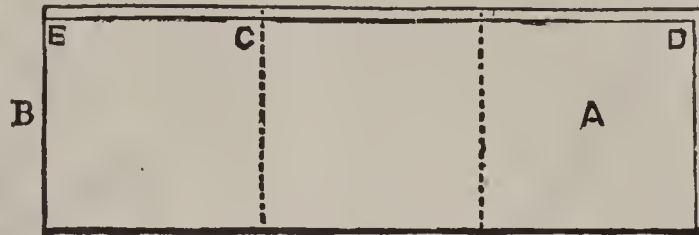

FIG. 1.

using a little pin at the back of the waist, marked C to D in diagram (fig. 5). Rich heavy damask of a large size is always tiresome to fold without starch' although looking whiter, brighter, and handsomer on table. Lay the serviette flat on the table: fold it in half; and in half again, lengthwise; keeping the

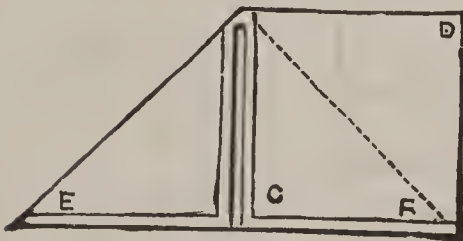

Fig. 2.

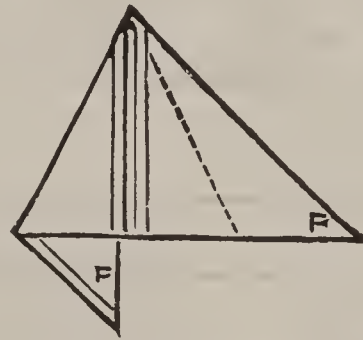

Fig. 3.

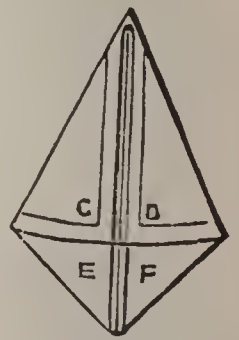

Fig. 4.

selvages all to the top. Halve it the narrow way, A to B (fig. 1). Merely make the crease, and open this last fold again: thus you have the centre marked. Take



Fig. 5.

the ends E and D, and fold them to the centre: you thus have an oblong, equal to two squares. Turn down the corner E, and you have a resemblance to fig. 2. Take the point D in that diagram, and bring it to C. Take the point E and turn it under to C, in the way shown in fig. 3. Treat the point F in the same manner. Thus fig. 4 is made. Double fig. 4 in half, flat from A to B. Hold it tight between the thumb and finger at C and D. Take hold of the points at A and pull them out to resemble the petals of a Fleur-de-Lys, like fig. 5. Turn up the corners, E and F, at right angles to stand it upon, pinching the waist well in. If not quite stiff enough to stand alone, after being pinched a moment, place a pin at the back of the waist; but pins are always better avoided.

### THE ARCHBISHOP'S, OR DOUBLE MITRE.

The Archbishop's, or Double Mitre, is exceedingly pretty, and may be folded from any serviette. First fold the linen in half, and lay it flat on the table. Turn down six inches from the top. Fold down an inch and a half of this at the edge, and fold that over again; the folds forming an outside band like that shown in

fig. 1, from A to B. Raise the ends A and B in the hand, and form the point C, in fig. 2, allowing the folds of the linen to overlap a little. Smooth it down flat,

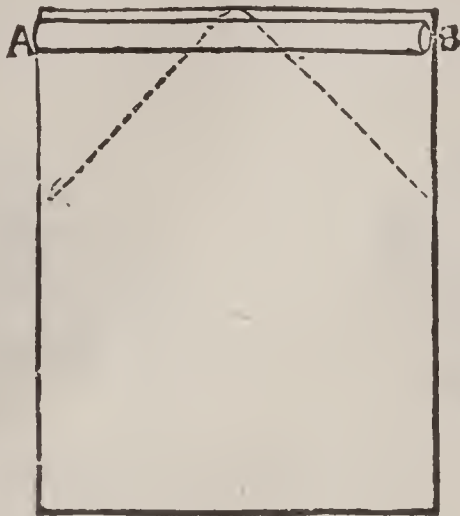

Fig. 1.

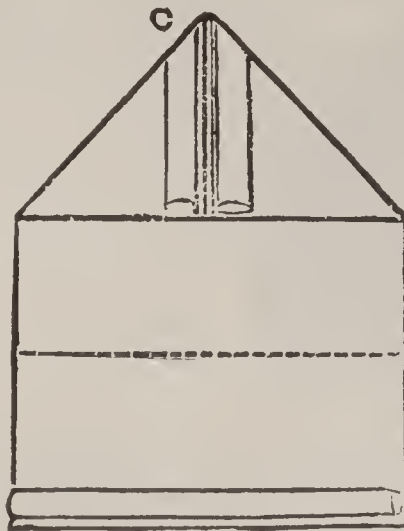

Fig. 2.

without raising or moving it from the table; fold the lower end the same, and bring it up to D E, in fig. 3. Turn the fold D E, down on the right side, and make another point with it like that at C, in fig. 2, but a little lower, so as to show the top point above it. Lastly, fold up the lower edge F G, about an inch and a half, to form the band of the Mitre.

Bring the two ends F and G, round to the back, to make the shape of a cap, and insert one in the other. If large enough, fix it over the dinner roll. If not, set it on

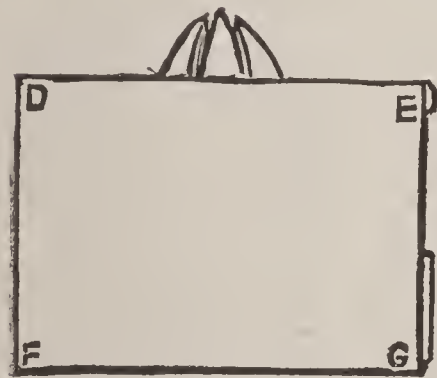
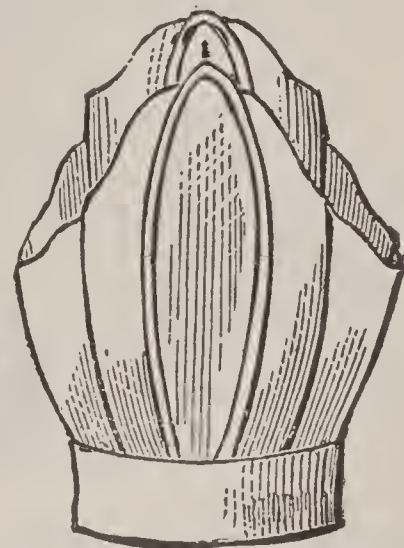

Fig. 3.

the table, and place the roll upright in the hollow. The front should face the guest.

**THE BREAD BASKET.**

Fold the serviette four times lengthways. Turn down the corners in the way observed in fig. 1. Make the three standing folds A across the centre, the middle one to project, C and D to bend inwards. This makes

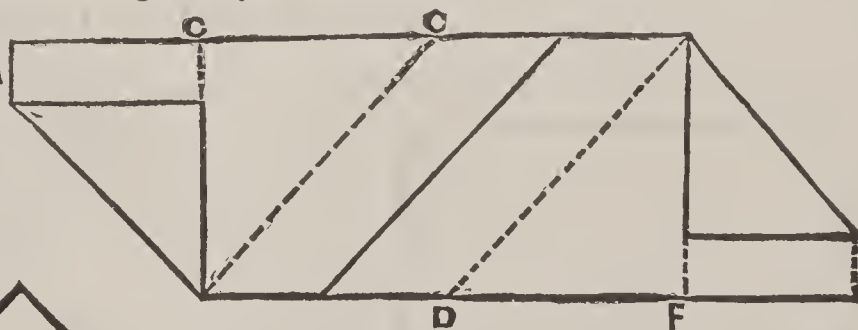

Fig. 1.

a hill or ridge in the centre. Fold back each corner at the dotted lines F and C. Now hold it erect like fig. 2. Pinch it up together in a flat line.

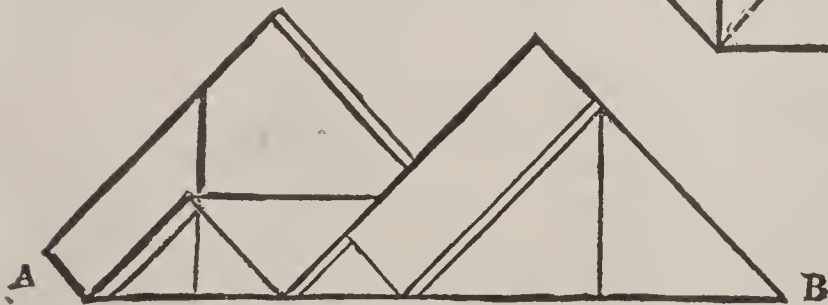

Fig. 2.

Make a circle of it by bringing the ends together and inserting B in A. Place it round the bread.

### THE FLOWER BASKET.

Take a very stiff square of damask, and fold it exactly in half. Open and fold in half the reverse way. The centre is now ascertained. Fold all the corners very exactly to the centre. Iron them

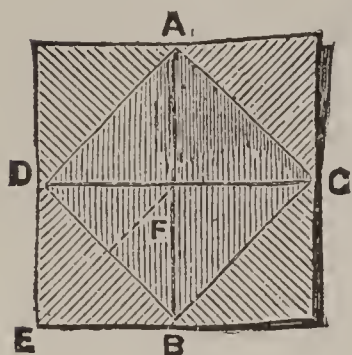

Fig. 1.



Fig. 2.



Fig. 3.

down; turn over, and again turn the corners to the centre. Turn the serviette over again and take each corner from the centre, and fold it back at the half. Then crease it from A to B (fig. 1), open the crease, and fold it again from C to D. Take it in the hand and bring the crease A to C, and C to B, and so all round. This will enable you to make it stand. Hold the apex between the

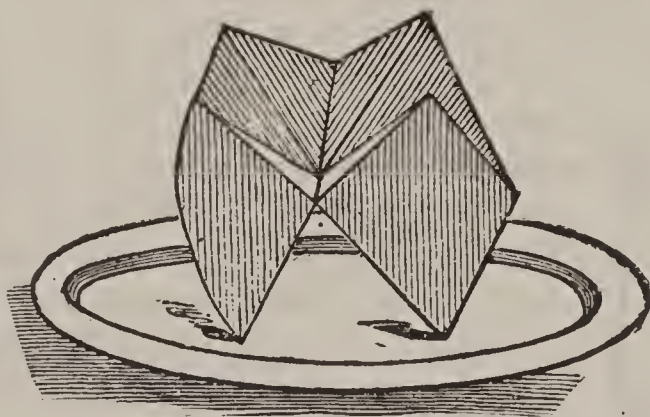

Fig. 4.

fingers of one hand and square out the four sides. This makes it resemble fig. 2, and completes it. A few flowers should be arranged in the compartments. For variety the corners may be left upright, like fig. 3. By reversing it, as shown in fig. 4, a different design is obtained.

### THE IMPERIAL CROWN.

The Imperial Crown requires very stiff damask—an exact square is best,—and

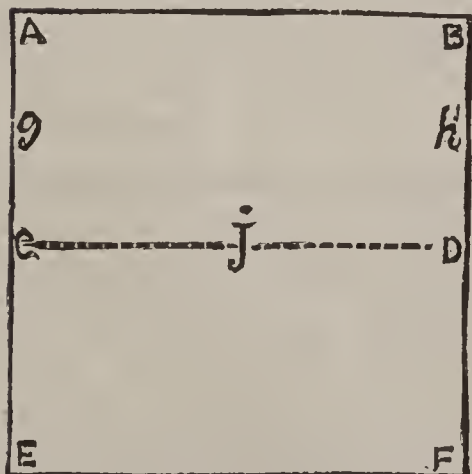

FIG. 1.

either a very small serviette, or a very large one folded in four, to reduce it to a quarter its size. Lay it flat on the table: fold the end, A B, over to the dotted line in the centre, C D. Do the same the other side, bringing E F to C D. Then place the end, A B, in three folds, as for a fan, the whole length of the damask, and

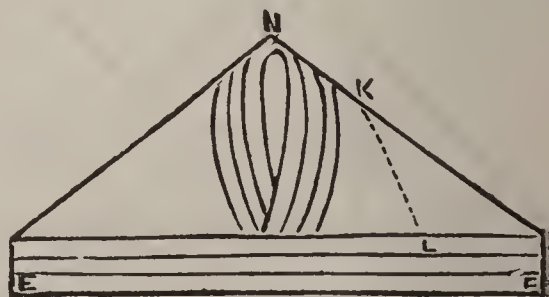
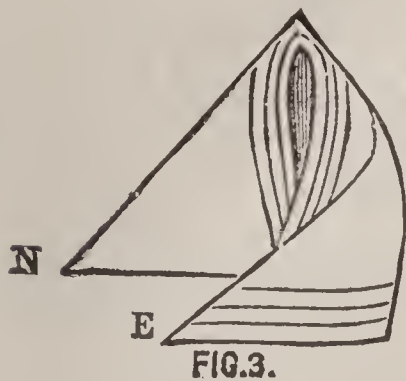

FIG. 2.

crease them down, making the folds exactly use the piece between A B, and the

fold at *g, h*. Then fold the end, *E F*, to match. Then bring the folded ends, *A B*, to the centre, *j*, crossing the folded part of one over the other where they meet. The serviette will now look like fig. 2. Turn the fold, *E F*, to the back and fold down. Next bring the corner *E*, by the dotted line *K L*, completely across, like fig. 3; the end *N* is to be level with the end *E*. The end *N*



is then to be crossed over to match, and the end of the band inserted in the folds of the other, so as to hold firmly together. Put the hand inside and shape it. When set over the dinner roll it will stand firm. It should be a full-sized roll. The front of the hat should face the guest. If the *carte de menu* is not too large, it may be placed in



the plaited fold at *N*, before crossing the ends over.

### THE DOUBLE HORN OF PLENTY.

This requires a stiff serviette, damp and fresh ironed. It may, however, be

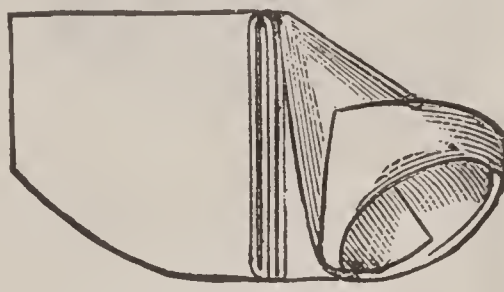
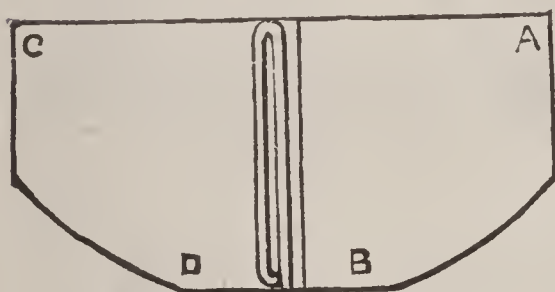

made from a limp one, if a small pin is inserted at each side, after the last fold. Lay the serviette flat on the table; fold in four lengthwise, keeping all the selvages one way. Turn the two ends to meet in the centre. Turn that over, and turn down two corners not at the selvage edge, at the lines *A to B*, and *C to D*. Turn it over and it will resemble fig. 1. Take the end *C*, and roll it over to *D* (see fig. 2). Bring *A to B* in the same manner, and complete the design. It is most suitable for a Christmas dinner party, when it may be filled with holly or any bright flowers; or one space may

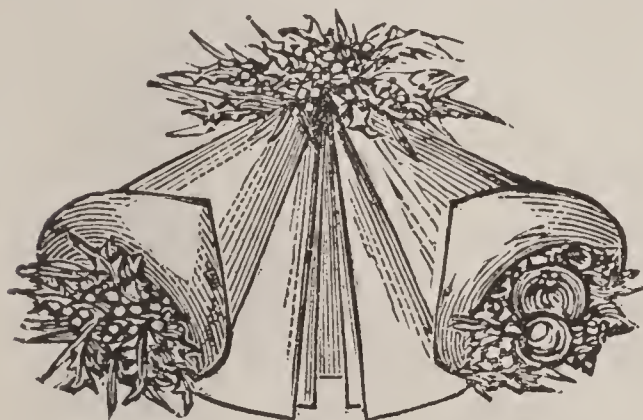

be filled with holly and the other with grapes, almonds, raisins, &c., to represent plenty (see fig. 3). Pinch the horns down and hold them a minute, to make them preserve their shape.

### THE COLONNE DE TRIOMPHE.

This is difficult to fold, although it may be done with a soft damask. Starch is, however, an improvement. The secret of success depends entirely on rolling it *very* lightly. Lay the serviette flat on the table. From *A to B* (fig. 1), fold

down about six inches, if it is a large serviette. After trying the fold once, by

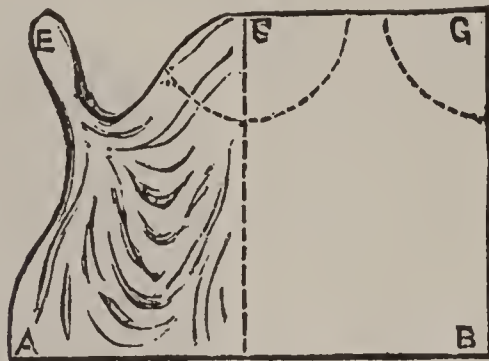

FIG. 1.

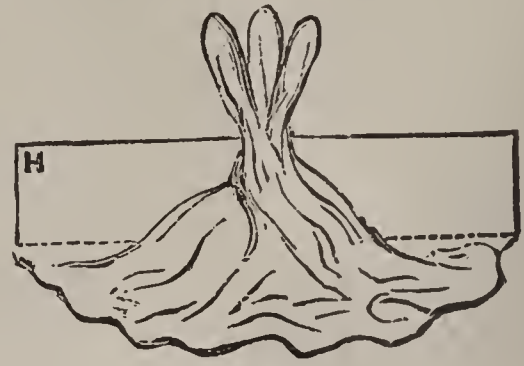

FIG. 2.

reference to the illustration, it will be seen if the proportion is properly kept. The one which we have just folded ourselves, as a model, stands fifteen inches

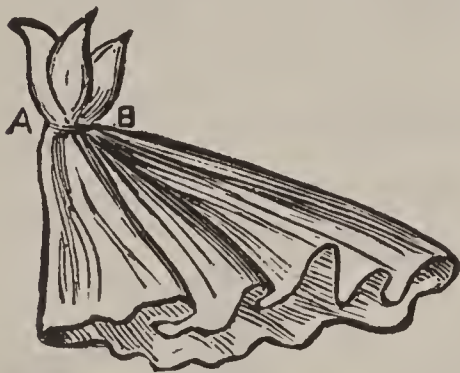

FIG. 3.

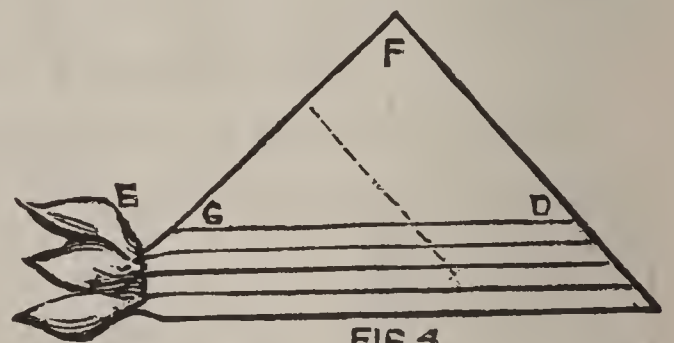

FIG. 4.

high, eleven for the shaft of the column, and it is very erect and firm, although made of limp damask. Fold the damask in half from C to D (fig. 1), to ascertain the half. In the left hand nip up the corner E, as shown in the illustration; the centre C and the corner G in the same way, like fig. 2, shaping them into laurel leaves. Then pleat down the serviette, holding the top still in the hand, in the way described in fig. 3. Next take the end H (fig. 2), that is, the left hand lower corner, and pass it completely round the serviette to the right, bringing the selvage tight round from A to B in fig. 3. Lay it on the table, holding the neck at E grasped in the hand, at first; and tucking down and keeping tight the folds from C to D (fig. 4), whilst rolling over the end E to F, as tightly as possible, umbrella wise; pressing it on the table as you roll it up, to keep it firm. Fasten the end with a little pin. Then firmly tuck in the odd corners at the base, in the way half a pound of sugar or an ounce of almonds are turned in. Twine a wreath of flowers around it. The artificial wreaths of small roses or holly, sold at the grocers', are pretty for the purpose. Set it upright, and with a little manipulation it will sit firm in the plate.



FIG. 5.

### THE TULIP.

The Tulip requires a very stiff material. The folds are very simple, but require nicety of fingering and pressure with a hot iron. Bring all the corners



to the centre, as for the Crown. Bring the corners down to the centre again and again; in all five times. Press it well. Finish all the serviettes to be folded



so far, and then recommence with the first by turning down all the corners one by one, to form the Tulip petals, which should hang down in long points, like a dog's ears. Place the Tulip on a glass.

### THE BRIDAL SERVIETTE.

The Bridal Serviette is almost identical with the Pyramid, and is so called because it is a favorite for wedding breakfasts. At the top it is to be decorated with a few flowers. For

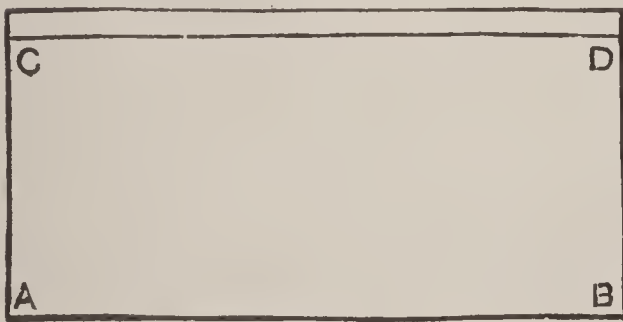

FIG. 1.

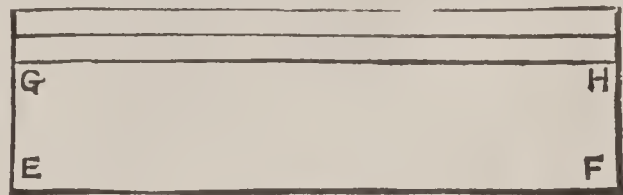

FIG. 2.

the bride, stephanotis, white roses, or any white flowers available, mixed with a little orange blossom. For the other guests, scarlet flowers. The serviette must be very stiff and damp from fresh ironing. Lay it on the table flat. Fold it not in half, but within an inch and a half of the top (see fig. 1). Take the corners A and B, and fold them to C and D again, within an inch and a half of the last fold, and like the last fold flat and straight across. This produces fig. 2. Again take the ends E and F and fold over to G and H, within an inch and a half of the last fold. This will probably about halve the remaining piece; but that will depend on the size of the serviette. Then fold it the narrow way, backwards and forwards, as for a fan, nine times, creasing it firmly down. Opening it as little as possible, turn down all the tops of the folds in the way noticed in fig. 3, beginning at the top of the three tiers. Then join it round, fixing the first fold over the last, and pinch it together at the top.

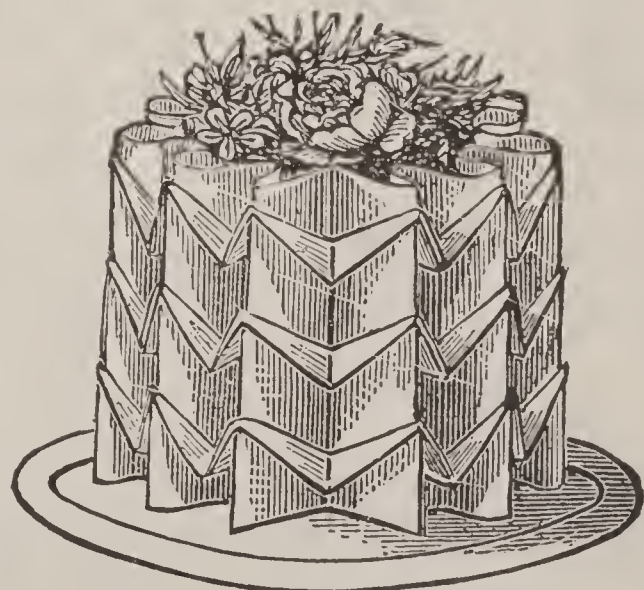
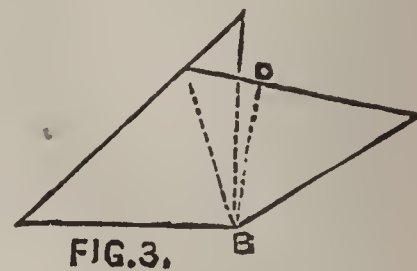
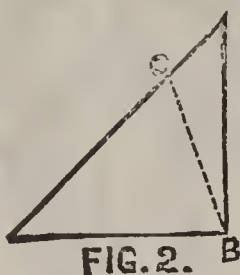
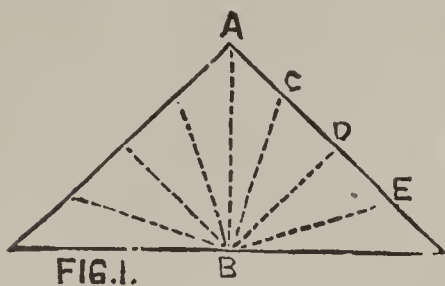

FIG. 3.

THE PRINCE OF WALES'S FEATHER.

The Prince of Wales's Feather is a perfectly new design, invented especially for the present work. It is simple in effect and very handsome in appearance. It requires a very stiff crisp serviette. Lay the damask on the table, ironing it



damp. Fold it from fig. 2 in the Crown, from A to B, using the hot iron to crease it. Without disturbing this fold, crease in half again the reverse way, from C to D, thus reducing the size to a quarter. Smooth it with the iron. Next fold this in half diagonally, like fig. 4 in the Crown. Observe fig. 4, in the

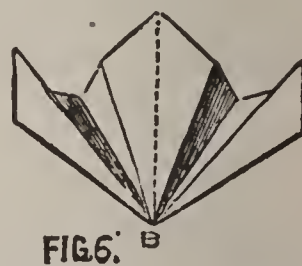
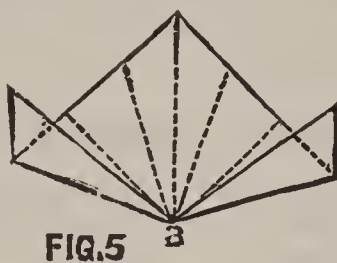
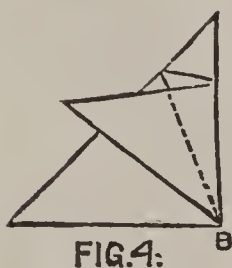

illustrations on the present page, carefully. Fold it in half from A to B, using the iron; this will produce fig. 2. Make the fold C to B, on one side only, in the manner shown in fig. 3. Then fold it back again at the dotted line D, and it will resemble fig. 4. Fold the other side to match, always using the iron to press every fold. Open it and it will resemble fig. 5, with the folds A, C, D. Make the folds, E, as shown in fig. 5, taking care not to flatten the other

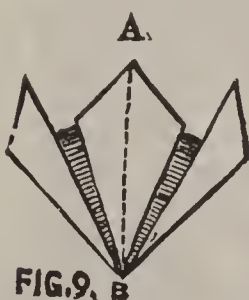
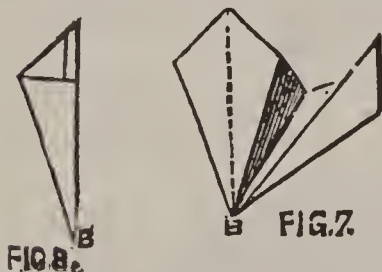

to ds, leaving the serviette only just open enough to make the folds, E, each side. It now resembles fig. 6. Bring the last two folds quite flat and inside C and D, and it will resemble fig. 7. Treat the other side the same, and then fold it in half in the middle, A, and it will resemble fig. 8. Now allow it to open a little and hold it by the apex, B, fig. 9. Keep it very much indented

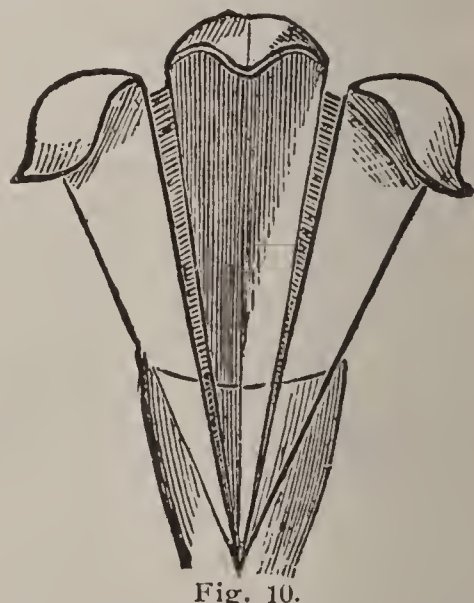

in the centre (A to B); bring the wings or side feathers rather forward, and curl over the three tips of the feathers by bending them with the fingers. Place it upright in a wine glass or a slender single flower glass in the same manner as the Fan is placed. Fig. 10 shows the Prince of Wales's Feather complete.

**THE ARROW HEAD.**

Fold the napkin in half lengthwise to the right, and turn down top edge A A by dotted line X X to centre line C C; repeat the same with bottom edge B B by dotted line O O to centre line C C, as shown in fig. 1; it will then appear like fig. 2. Next proceed to fold in half towards you by

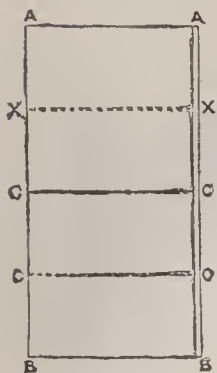

Fig. 1.

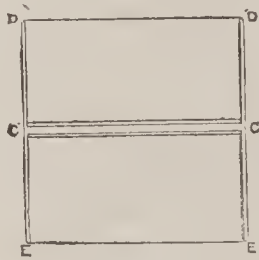

Fig. 2.



Fig. 3.

turning down top edge D D by centre line C C to bottom edge E E, which makes it resemble fig. 3. In this figure lift up the edge F F at bottom, and bring the right-hand top corner C, tucking it under edge held up by left hand until it comes level with centre line X X; repeat the same with left-hand top corner C, bring it underneath bottom edge F F, which must now be held up by right hand until the corner C comes level with centre line X X, and level with the right-hand corner previously tucked underneath; it will then form fig. 4. Now fix it upon the bottom

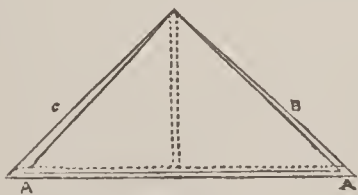

Fig. 4.

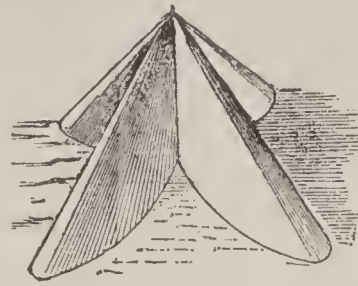

Fig. 5.

edge A A, open out the sides right and left at B and C equal distances all round. It is then finished as seen in fig. 5. Dinner rolls can be placed in any of the recesses.

**THE MENU HOLDER.**

Fold the napkin into three parts lengthwise, as seen in fig. 1, then take the right-hand end A A and fold in to the centre marked X X; repeat the same with left hand B B to the centre line X X, depicted in first fig.; it then forms fig. 2. In this diagram turn down the right-hand top corner C to centre X X, repeat the



Fig. 1.

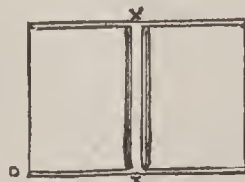

Fig. 2.

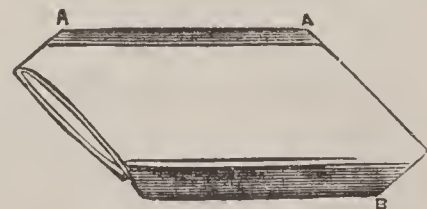

Fig. 3.

same by turning up the left-hand bottom corner D by dotted line; turn the whole over, keeping the points right and left of you, as seen in fig. 3. In this diagram turn down top edge A A to bottom edge B B, at the same time giving the left-hand

corner a lift upwards, so as to allow the underneath point to appear; it will then resemble fig. 4. Proceed now by turning the right-hand corner A by dotted line X X, lifting with the left hand the uppermost point marked E, and put the right-hand-corner under it; turn the napkin over to the left, and repeat the same with another corner B, which appears to the right hand by dotted line X X; tuck this between the edges at C, crease the whole well, then open bottom edges and fix up, pressing the centre part down, where the dinner roll or a piece of bread may be put or underneath or

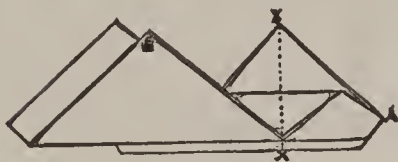

Fig. 4.



Fig. 5.

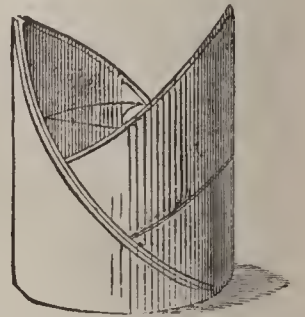

Fig. 6.

the menus can set in on top, and you have this pattern finished as seen in fig. 6

### MERCURY'S CAP.

Commence this design by opening out the napkin with points to and from and right; and turn down all the corners to the centre, thus reducing the square smaller, turn the napkin over to the right, keeping the points in the same places as at commencement; it then appears like fig. 1, except that the points are all underneath. Next turn up the point nearest you marked A by dotted line to B.

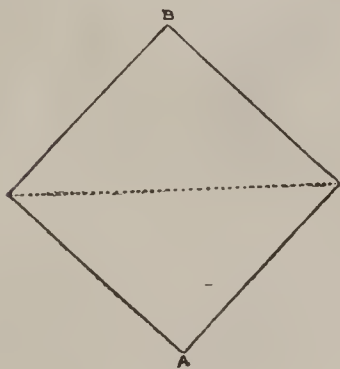

Fig. 1.

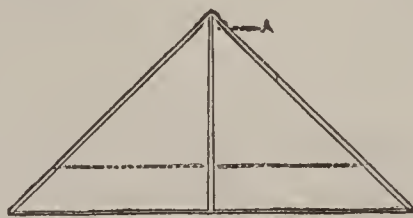

Fig. 2.

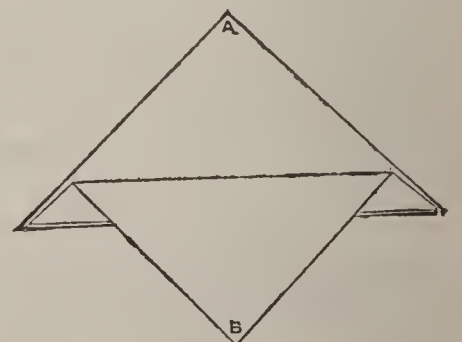

Fig. 3.

You now get fig. 2; and in this figure turn down the uppermost of the two top corners marked A by dotted line seen about three parts down shown in diagram; it then forms fig. 3. Turn the napkin over to the right. You then get a similar figure to last. Turn down the top point A to bottom point B, and it forms fig. 4. Now turn the napkin over towards you, and the points will then be a top like fig. 5. In this figure all that remains to do is to turn down the uppermost top



Fig. 4.



Fig. 5.

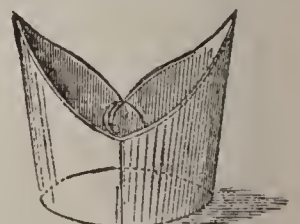

Fig. 6.

corner, and turn the right-hand corner B underneath by dotted line until it reaches centre of points. Put back the point just turned down from top. You

then still have two points at top. Turn the napkin over to the right, and do the same with the other corner, which is now to the right hand, by tucking it underneath the uppermost top corner; and the Cap is complete by setting it up like fig. 6, showing it finished.

### THE SAIL BOAT.

In commencing this beautiful fold, you must open a napkin out square in front of you, and turn down top edge by the middle until it reaches the bottom edge near you, then take the left side A A in fig. 1 over to right side B B by dotted line X X; you then still have a square napkin as at commencement, only a re-

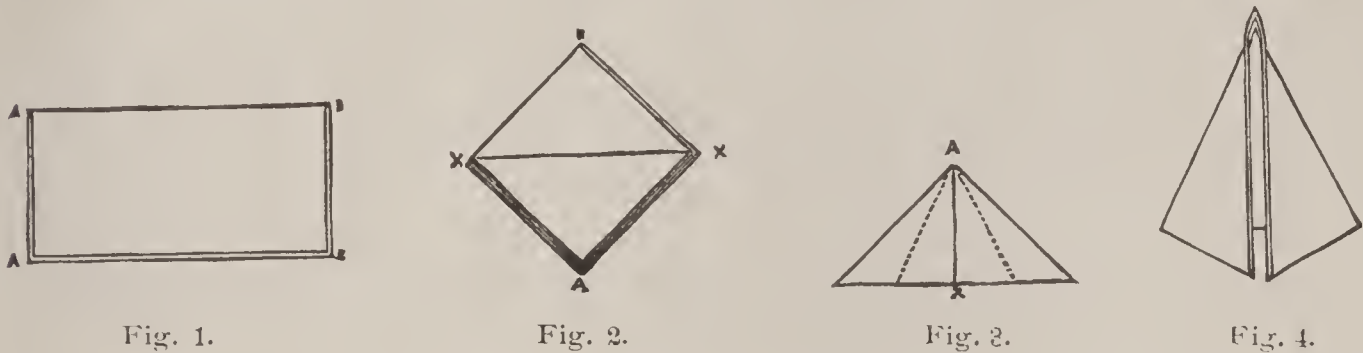

duced size. The four points of the napkin are now at right-hand bottom corner, which points must be moved pointing directly towards you, as depicted in fig. 2: and in this diagram fold the napkin in half, taking the part marked A near you to top corner B by dotted line X X, when it will then resemble fig. 3. Proceed to turn the right-hand side by dotted line to centre X X, and repeat the same with the left hand; you then get fig. 4. Turn the whole over, and turn up the bottom points A A by line X X in fig. 5, and close it like a book by the centre, and you then get fig. 6. If you look carefully at the top corners of this diagram you will

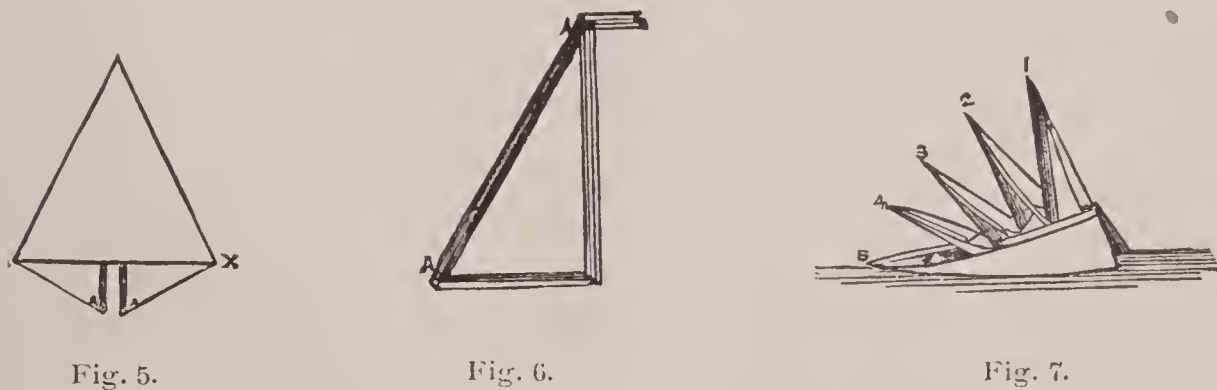

see there are four points, indicated by the figures 1, 2, 3, 4. Turn the napkin on the edges on left side of fig. 6 marked A A, or hold the napkin by the same edges in the left hand, and commence to pull up the points, with No. 1, continuing with the other numbers until they are all standing up, as seen in fig. 7; those points give the appearance of sails. The yacht is then finished, and a little manipulation with the fingers and these points can be made to have a very pretty effect.

## HOTEL NAPKIN FOLDING.

### AN ART WORTH MORE THAN FOREIGN LANGUAGES.

The art of folding napkins is the most valuable accomplishment a waiter can acquire. There are some who contend that a waiter cannot be considered completely equipped for his profession without knowledge of several languages; still it must be owned this knowledge of various tongues is only useful in the city restaurants frequented by strangers to the country while a waiter may spend his life in good hotels where linguistic accomplishments are never called into play. Not so however, with the art of folding napkins. It is needed everywhere. There is nothing a waiter can do that is at once so interesting and so quickly proves him to be what he says he is, a man who understands his business. There is nothing he can do, if a stranger in a strange place that will so quickly give him introductions and acquaintance as to take a dozen sheets of stiff white paper and with them instead of napkins execute the finer patterns shown in this book and set them up for display. They attract attention at once and prove better than a letter of introduction for a young man seeking employment, and, fortunately, this useful art is far easier to learn than a foreign language.

### NAPKIN FOLDING TO MAKE MONEY.

In our talk about waiters it is several times mentioned that there are what are called *good* tables to which the best or most deserving waiters are allotted. In the case of a Paris café it is shown that these best tables are only reached by slow promotions and delinquent or absentee waiters are invariably placed at the bottom or worst tables when they return to work and have to progress to the better places slowly. The meaning of good tables is that they are occupied by guests who pay their waiter well; the worst tables are those frequented by, let us say, "dead-heads," or by some sort of customers of whom little or nothing is to be expected. It is precisely the same in our hotels and perhaps most markedly the case in pleasure resorts where families take up their summer or winter residence, occupy the same tables through the season and pay their waiter well. The headwaiter gives such tables as favors to the waiters he likes the best, and if he does not like a waiter he can keep him down to a table where he cannot make a dollar. The best way a waiter can help himself and make it so the headwaiter cannot afford to keep him down is to learn to be a boss napkin folder; if he is the best folder in the dining room he has a big advantage; he will be always needed, and needed at the best tables. Perhaps the reason of this is not plain to all, it is because the best guests expect all sorts of elegant little attentions and must not see the next table to them faring better than they. The waiter brings in various things upon folded napkins and if he could not produce ornamental effects that way he could not be in such a position. When, for example, he brings in the various cut cakes, macaroons and bonbons, he provides himself with, say, the "Chestnut Pocket" on page 8 or the "Heraldic Rose" and cross, page 14, not caring for the cross but opening up the pockets and filling them with the handsomest and most delicate confections he can obtain at the pantry or fruit room. The cheese and crackers he brings in

another pattern; the table he has already furnished with such a pattern at each plate as the "Flower Basket." page 20, or what not, while his rival at the next table may be trying himself to do something still better. These attentions are practiced by the waiters because it pays them to do so; the people at the good tables appreciate them, and moreover, they expect them and the head waiter is obliged to find waiters who can meet these expectations. Some of the handsomest folds are capable of many changes; the "Heraldic Rose" when opened up is known as the "Boston Fold," the "Flower Basket" with the points up is known as the "Saratago Fold," but several of these might as well be called the "Tip Catcher," the "Remember Me," the "Christmas Gift Collector," etc.

### NAPKIN FOLDING FOR EFFECT.

Napkins there must be at every dinner in every hotel of the least pretensions to elegance and it is a waste of a grand advantage not to make use of them for ornamental effects by employing the more imposing forms of folding them for setting on the table in readiness for the dinner. The use of the napkin to hold the dinner roll or piece of bread is a fashion of private table-setting and for caterers for private parties, but the piece of bread to each plate is not a hotel custom, it is not suitable. The flat folds of napkins instead are used as above named to bring pretty things to table in and to hold buttonhole boquets or the menu. Where the napkin and the art of folding shows up the grandest is in the hotel dining room with its fifty tables, its hundreds of plates, its long white rows of Pyramids, Hamburg Drums, Tulips, Palm Leaves, Double Fans; Columns, Crowns, Mitres, any of them, the taller the better, all alike, of course, on each day but changed in form every day. That indeed is a sight that is pleasing alike to hotel man and guest and for good reason; it is a scene of real beauty and symmetry of forms and distances, pleasing by its whiteness and intimation of cleanliness and purity. It is something much too ornamental and satisfactory to be lost to a dining room for want of a knowledge how to fold napkins.

### THE WAY TO LEARN.

Learn the folds by using good stiff white paper, the size is of but little consequence. The apparent difficulty of following the diagrams and directions vanishes after one trial, and when the folds have been carried out with a sheet of paper a stiff napkin can be tried with a better chance of immediate success. Some of the forms which require a hot iron for every fold are hardly practicable for use in hotels except for special party occasions, but there are plenty of easy forms that do not consume much time and some of them produce as good effects in ornamenting the dining room as the most difficult shapes could do. Take this simplest of all for example, and look down a long dining room with this pattern set at every plate. The waiters on watch can roll up enough of these without calling on the off watch for help; but the finer patterns can be brought in on Sundays.



The Excursionist.

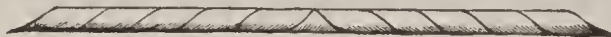

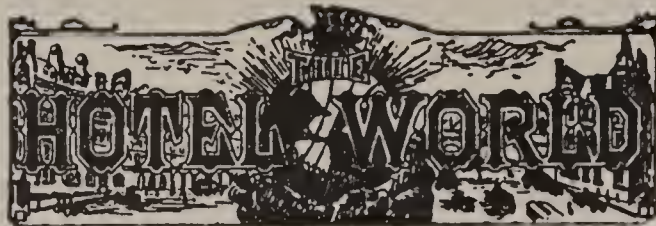

CHICAGO.

←PUBLISHED WEEKLY→

HENRY J. BOHN.

JOHN J. BOHN.

H. J. BOHN & BRO.,

Editors and Publishers.

THE HOTEL WORLD was established in 1875. It is the oldest, largest and leading weekly hotel journal. Publishes more original hotel news, editorial, and articles on hotel-keeping than all other hotel papers put together. Price: \$2.50 per annum; with 1-line advertisement, \$5.00. Every Hotel Steward should be a subscriber. We also make and sell all kinds of copyrighted blank hotel books, and every description of cook books and other hotel books.

N. B.—The plates on pages 182 and 183 of this book show the plan of our Store Room Issue Book. 372 pages; price, \$4.

# THE CATERER

AND

## HOTEL PROPRIETORS' GAZETTE.

(PUBLISHED MONTHLY.)

IS REplete WITH

PRACTICAL, USEFUL AND VARIED INFORMATION

FOR THE

### CONFECTIONER, BAKER AND PASTRYCOOK

YEARLY SUBSCRIPTION, \$1.25, POST FREE.

PUBLISHED BY

NEWTON & ESHELL, 20 HIGH HOLBORN,

LONDON, ENG.



# WHITEHEAD'S HOTEL COOK BOOKS.

## No. 1.—“THE AMERICAN PASTRY COOK.”

(FIFTH EDITION.)

PRICE, POSTPAID, \$2.00.

EMBRACES THE FOLLOWING:

**PART FIRST**—The Hotel Book of Fine Pastries, Ices, Pies, Patties, Cakes, Creams, Custards, Charlottes, Jellies and Sweet Entremets in Variety.

**PART SECOND**—The Hotel Book of Puddings, Souffles and Meringues. A handy Collection of Valuable Recipes, original, selected and perfected for use in Hotels and Eating Houses of every Grade.

**PART THIRD**—The Hotel Book of Breads and Cakes; French, Vienna, Parker House, and other rolls, Muffins, Waffles, Tea Cakes; Stock Yeast and Ferment; Yeast raised Cakes, etc., etc., as made in the best hotels.

**PART FOURTH**—The Hotel Book of Salads and Cold Dishes, Salad Dressings, with and without oil; Salads of all kinds, how to make and how to serve them; Boned Fowls, Galantines, Aspics, etc., etc.

☞ The above parts are all comprised in the “AMERICAN PASTRY COOK,” together with a large amount of valuable miscellaneous culinary matter.

## No. 2.—“HOTEL MEAT COOKING.”

(FOURTH EDITION.)

PRICE, POSTPAID, \$2.00.

EMBRACES THE FOLLOWING:

**PART FIRST**—The Hotel, Fish and Oyster Book; Showing all the best methods of Cooking Oysters and Fish, for Restaurant and Hotel Service, together with the appropriate Sauces and Vegetables.

**PART SECOND**—How to Cut Meats, and Roast, Boil and Broil. The entire trade of the Hotel Meat Cutter, Roaster and Broiler, including “Short Orders,” Omelets, etc.

**PART THIRD**—The Hotel Books of Soups and Entrees, comprising specimens of French, English, and American *Menus*, with translations and comments. Showing how to make up Hotel Bills of Fare, with all the different varieties of Soups and Consommés in proper rotation, and a new set of entrees or “made dishes” for every day.

**PART FOURTH**—Creole Cookery and Winter Resort Specialties.

**PART FIFTH**—Cooks' Scrap Book—A Collection of Culinary Stories, Poems, Stray Recipes, etc., etc. Index of French Terms, an explanation and translation of all the French terms used in the Book, alphabetically arranged.

☞ The above parts are all comprised in “HOTEL MEAT COOKING,” together with a large and varied selection of matter pertaining to this part of the culinary art.

## No. 3.—“WHITEHEAD'S FAMILY COOK BOOK.”

PRICE, POSTPAID, \$1.50.

A PROFESSIONAL COOK'S BOOK FOR HOUSEHOLD USE.

Consisting of a series of *Menus* for every-day meals, and for private entertainments, with minute instructions for making every article named.

The Recipes in all these books are properly headed, numbered and indexed, for handy reference.

The author of this series of Hotel Cook Books is a professional Cook of Thirty Years' experience, and every recipe has been tried and practically proved.

The above books will be sent postpaid on receipt of price: “American Pastry Cook,” \$2.00; “Hotel Meat Cooking,” \$2.00; “Family Cook Book,” \$1.50. All three will be sent to one address on receipt of \$5.00. Address all orders to

*Jessup Whitehead,*

*Publisher of Hotel Cook Books,*

OFFICE WITH  
**JOHN ANDERSON & CO.,**  
Booksellers and Publishers.

**183 North Peoria Street,  
CHICAGO, ILL.**

The Famous California Book of **COOKING, STEWARDING, CATERING,**  
and **HOTEL KEEPING,** called

# Cooking for Profit

AND EIGHT WEEKS AT A SUMMER RESORT.

**Two Books in One. About 400 Pages.**

A Remarkable Volume which shows how Money is made by Boarding People and What it Costs to Live Well.

**SECOND EDITION. - - PRICE, \$3.00.**

For Sale at the Offices of all the Hotel Newspapers and Summer and Winter Resort Journals, and by the Author and Publisher,

*Jessup Whitehead,*

183—187 North Peoria St., CHICAGO, ILL.

## CONTENTS.

**PART FIRST**—Some Articles for the Show Case. The Lunch Counter. Restaurant Breakfasts, Lunches and Dinners. Hotel Breakfasts, Dinners and Suppers. Oyster and Fish House Dishes. The Ice Cream Saloon. Fine Bakery Lunch. Quaker Dairy Lunch. Confectionery Goods. Homenade Beers, etc.

**PART SECOND**—Eight Weeks at a Summer Resort. *A Diary. Our daily Bill of Fare and what it costs.* A Party Supper for Forty Cents per Plate. The Art of Charging Enough. A School Commencement Supper. Question of How Many Fires. *Seven Fires for fifty persons vs one Fire for fifty.* The Round of Beef for Steak. A Meat Block and Utensils. Bill of Groceries. *A Month's Supply for a Summer Boarding House, with Prices.* A Refrigerator Wanted. *About keeping Provisions; Restaurant Patterns.* A Good Hotel Refrigerator. *Cost of Ice to supply it.* Shall we have a Bill of Fare? *Reasons why: a Blank Form.* Is Fish Cheaper than Meat? Trouble with the Coffee. How to Scrub the Kitchen. Trouble with Steam Chest and Vegetables. Trouble with the Oatmeal. Building a House with Bread Crusts. Puddings without Eggs. A Pastry and Store Room Necessary. A Board on a Barrel. First Bill of Fare. Trouble with Sour Meats. Trouble with the Ice Cream. The Landlord's Birthday Supper. *Showing how rich and fancy Cakes were made and iced and ornamented without using Eggs.* The Landlady's Birthday Supper. Trouble in Planning Dinners. Trouble with Captain Johnson. Trouble in Serving Meals. Trouble with the Manager. Breakfasts and Suppers for Six Cents per Plate. Hotel Dinners for Ten Cents per Plate. Hotel Dinners for Seventeen Cents per Plate. Supper for Forty for Eight Cents per Plate. Breakfast for Forty for Nine Cents per Plate. An Expensive Wedding Breakfast, *for the Colonel and the Banker's Daughter.* Four Thousand Meals. Review Groceries for 4,000. Meat, Fish and Poultry for 4,000. Flour, Sugar and Coffee for 4,000. Butter and Eggs for 4,000. Potatoes, Fresh Vegetables and Fruits for 4,000. Canned Fruits and Vegetables for 4,000. Milk and Cream for 4,000. Total Cost of Provisions for 4,000. How to Save Twenty Dollars per Week. How Much we Eat. How Much we Drink. How Much to Serve. Work and Wages. Laundry Work. Fuel, Light and Ice. Total Cost of Board. How Much Profit? How Many Cooks to How Many People? Boarding the Employees. Boarding Children. Meals for Ten or Fifteen Cents. Country Board at Five Dollars. If—a Bundle of Suppositions. Keeping Clean Side Towels. How Many Fires—Again. A Proposal to Rent for next Season. Conclusion.

### THE CONTENTS ALSO INCLUDE:

One Hundred Different Bills of Fare, of Actual Meals, all with New Dishes; the Amount and the Cost per Head.

Eleven Hundred Recipes. All live matter that every Cook needs—both by Weight and by Cup and Spoon Measure.

A Dictionary of Cookery, Comprised in the Explanations of Terms and General Information contained in the Directions.

Artistic Cookery. Instructions in Ornamentation, with Illustrations, and Notes on the London Cookery Exhibition of 1885.

It is thoroughly analytical, practical, readable, and the first book of the principles of the systematic hotel-keeping.

PRICE \$3.00. Address the Publisher, or any Hotel Paper.

## PREFACE TO WHITEHEAD'S NO. 4 COOKING FOR PROFIT.

---

This book is in many respects a continuation of the preceding volumes in the series, it fulfills the designs that were intended but not finished before, more particularly in the second part which deals with the cost of keeping up a table. It is not an argument either for or against high prices, but it embodies in print for the first time the methods of close-cutting management which a million of successful boarding-house and hotel-keepers are already practising, in order that another million who are not successful may learn, if they will, wherein their competitors have the advantage. At the time when the following introduction was written, which was about four years before the finish, I was just setting out, while indulging a rambling propensity, to find out why it was that my hotel books which were proving admirably adapted to the use of the ten hotels of a resort town were voted "too rich for the blood" of the four hundred boarding-houses; also, it was a question how so many of these houses running at low prices are enabled to make money as easily as the hotels which have a much larger income. At the same time some statistician published a statement that attracted attention showing that the vast majority of the people of this land have to live on an income of less than fifty cents a day. At the same time also an English author published a little book, which, however, I have not seen and did not need, with the title of "How to live on sixpence a day," (twelve cents) which was presumptive evidence that it could be done. In quest of information on these points I went around considerably and found a good many "Mrs. Tingees" who were not keeping boarding-houses, and I honor them for the surpassing skill that makes the fifty cents a day do such wonders; but the right vein was not struck until the opportunity occurred to do both the buying and using of provisions from the very first meal in a Summer Boarding House.

In reference to unfinished work I take the liberty here of saying that the bills of fare in this book with the quantities and proportions and relative cost from the continuation and complete illustration of an article entitled "The Art of Catering" in *Hotel Meat Cooking*. Knowing how much to cook, how much to charge, how to pre-

vent waste and all such questions raised there are carried out to an answer in these pages. In regard to the use of French names for dishes it is necessary that a statement should be made. A great reform has taken place in the last ten years in the composition of hotel bills of fare, and the subject matter of these books having been widely diffused by publication in the hotel newspapers, has undoubtedly had much to do with the improvement that is now observable. My own design was, however, to explain French terms, give their origin and proper spelling, and to that end I had a mass of anecdotes, historical mention and other such material collected to make the explanations interesting. As a preliminary, I began exposing the absurdities committed by ignorant cooks and others trying to write French, and before this had proceeded far the newspapers took up and advocated the idea that French terms should be abolished altogether. If that was to be the way the knot of misspelling and misnaming dishes was to be cut, there was no use for my dictionary work and the material was thrown away; I followed the new path and it proves a plain and sensible one. At the same time there is an aspect of the subject which cooks seeking situations perceive and editors of newspapers may never think of, and that is that there are many employers whom the reform has not reached who will pay a hundred dollars for a cook who can give his dishes imposing foreign names more willingly than fifty dollars to a better cook who can only write United States. First class hotels which have all the good things that come to market avoid French terms. They that have turkey and lamb, chicken, peas and asparagus, oysters and turtle and cream want them shown up in the plainest reading; to cover them up with French names would be injudicious; but if we have but the same beef and mutton every day, the aid that a few ornamental terms can give is not to be despised. First of all it is requisite that those who use such terms should know what they are intended to indicate and how they should be spelled and then they can be taken or left according to the intelligent judgment of those concerned

I. W

# WHO CAN BEAT THIS?

TROPHY IN SUGAR WORK BY CHRIS. F. COLLMAR.

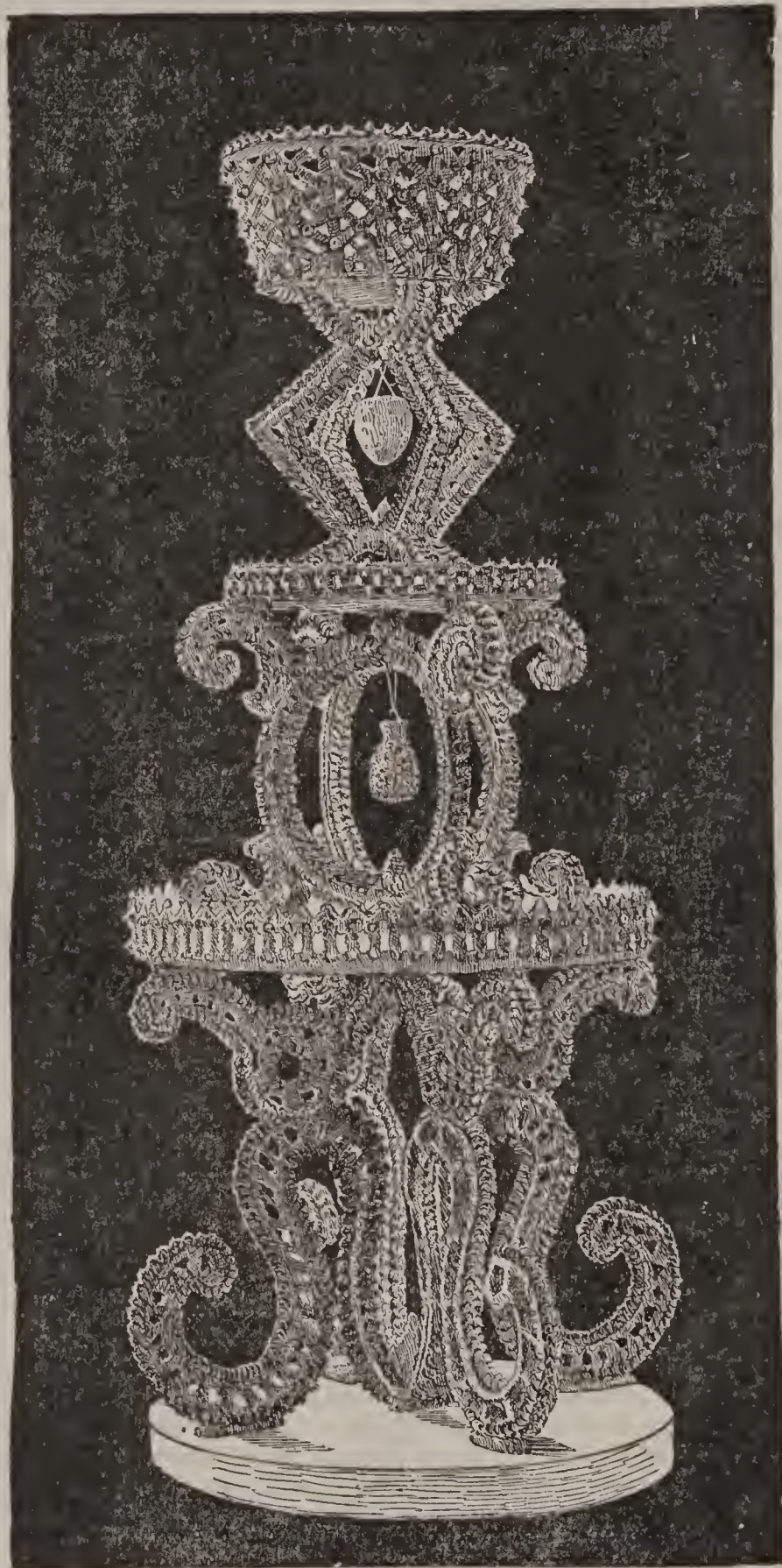

PHOTOGRAPHED BY HEADLEY & REED, NEW BEDFORD, MASS.

This exquisitely beautiful style of ornamental work in white icing is taught in *COOKING FOR PROFIT*—in the *ARTISTIC COOKERY* department of that book, and in no other book in the world. It is an original style; the whitest, most graceful, most effective for a banquet table; capable of endless changes of design, and not restricted as to size. This magnificent specimen, four feet in height, is the trophy of a first-class workman. Read his letter on the following page.

*Mr. Collmar's Letter Accompanying Photograph of Sugar Work:*

PARKER HOUSE, NEW BEDFORD, MASS., March, 1889.

MR. JESSUP WHITEHEAD.

*Dear Sir:*—Inclosed I send you \$2 for a copy of your "Hotel Meat Cooking" for another friend of mine. Also a photograph of a center piece of sugar icing work which I did in your style; what do you think of the design? I used it at the Board of Trade banquet here, and when it was filled up with small cakes and sugar fruits and decorated with smilax, it was much admired. The lower basket was 15 inches in diameter. The entire piece was 3 feet 10 inches high. I made the fruit of gum paste shaped in individual ice cream moulds.

Yours Respectfully,

CHRIS. F. COLLMAR,

New Bedford, Mass.

P. S.—I used 25 lbs. of sugar in the center piece.

---

"COOKING FOR PROFIT" also contains equally plain instructions for wax and mutton fat decorations for meat dishes. It would be worth more than its price if only for these special instructions; but besides that, it is the most useful, plain and practical book for the "all-round" cook who works up to a bill of fare that ever was printed. It is different from the others in containing both meat and pastry work in the one book, and plenty of bill-of-fare names. *Send for "COOKING FOR PROFIT." Price, \$3.00.* The second edition has recently been printed, the first having been sold out.

---

*The Hotel World*, of Chicago, has been publishing THE STEWARD'S HANDBOOK—the first part of it only and not the Dictionary—serially every week for more than *forty weeks*, and is to be credited with many of the quoted articles which have been clipped at various times from its varied pages and reproduced in the book where they will be permanently useful. *The Hotel World*, published by Messrs. Bohn & Bro., is a good paper to subscribe for.

J. W.











LIBRARY OF CONGRESS



0 014 759 353 3