

Class [redacted] Book [redacted]

72

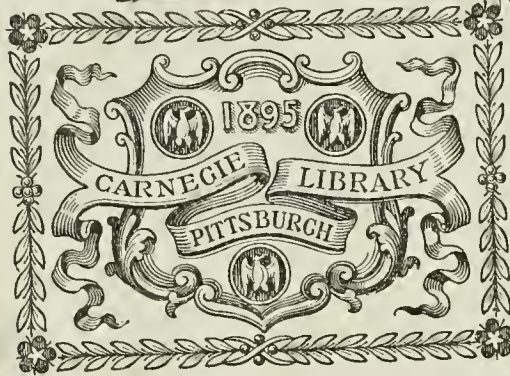





(ESTABLISHED 1832.)

AMERICAN ENGINEER

CAR BUILDER AND RAILROAD JOURNAL.

R. M. VAN ARSDALE, Proprietor.

G. M. BASFORD, Editor.

Published Monthly, at 140 Nassau Street, New York.

INDEX TO VOLUME LXXII.—1898.

(The asterisk indicates that the article is illustrated.)

Accidents, N. Y. C. & H. R. R., Garrison's	26	Baldwin Locomotive Works, Lehigh Valley	136*, 138*	Bridges, Life of Wooden.....	231
Accident to Engineer on Erie.....	406	Baldwin Locomotive Works, Lehigh Valley Engine	395*	Bridge Pier on N. P. Ry. Moved.....	274
Accidents to Trolley Cars.....	19	Baltimore & Ohio, Improved Train Loads	241	Brooklyn Bridge, Trolley Cars on.....	49
Acetylene Car Lighting in Canada.....	129	Baltimore & Ohio R. R. Presidents.....	47*	Brooks Locomotive Works, Gt. N. Ry. Engine	326*
Acme Heading and Forging Machine.....	171*	Battleships, New	267	Brooks Locomotive Works, Locomotives for Japan	105*
Acme Triple Bolt Cutter.....	379*	Bearing Metals, Microstructure of.....	312*	Brooks Locomotive Works, Gt. Northern Locomotive	1*, 51*, 84*
Air, See Compressed Air.		Bearing Metals, Segregation in.....	306	Brooks Locomotive Works, Locomotive.....	139*
Air Brake, Boyden Sold to Westinghouse.	241	Bell, J. S., Short Smoke Boxes.....	391*	Brooks Locomotive Works, W. C. Locomotive	192*
Air Brake Hose, Failures of.....	352	Bell Ringer, The Bartow.....	349*	Bronner, E. D., on Standard Trucks.....	257
Air Brake Hose, Service Tests.....	260	Belpaire Stationary Boilers.....	15*	Browne, T. R., Construction of Locomotive	79*, 116*, 147*, 187, 329*, 357*
Air Brake Hose, Specifications for.....	244*	Bessemer, Sir Henry, Obituary.....	131	Browne, T. R., The Machine Shop.....	329*
Air Brake Situation.....	408	Bilge Keels on Ships.....	93	Browne, T. R., Locomotive Building.....	357*
Air Brake Pump, Cylinders Jacketed.....	375	Bilgram's Valve Diagram.....	406	Business Problems, Motive Power Department	94
Air Brakes, Westinghouse, in Russia.....	237	Black Diamond Truck	53*	Burnishing Journals	337
Air Compressor, A Smooth-Running.....	310*	Blacksmith Shop, Operation of.....	187		
Air Compressors, Ingersoll-Sergeant.....	168*	Boiler and Cylinder Coverings, Tests.....	252*		
Air Hoist, Empire	99*	Boiler Cleaner, Hornish.....	413*		
Air Motor, Hardie, in Denmark.....	237	Boiler Feeder, Q. & C., Scott.....	48*		
Air Pressure Pump, Harrils.....	407*	Boiler for De Laval Turbine.....	302*		
Air Resistance of Trains, Goss.....	186	Boiler, De Laval's High-Pressure.....	6		
Air, Sample of Railroad Air.....	32	Boiler, Lagging, for Locomotives.....	78*, 103		
"All Work for Nothing".....	395	Boilers, Locomotive, Flanging of.....	149*		
Aluminum Conductors	342	Boilers for Locomotives, Large.....	269		
American Engineer, Subscriptions for....	90	Boilers, Weight Per Foot, Henderson....	389		
American vs. English Mechanics.....	173	Boiler, A Large "Scotch".....	92		
American Machinery, Yarrow's Opinion of	44	Boilers, Locomotive, Removable Covering	78*		
American Society of Civil Engineers, House	18	Boilers, Marine, New Rules.....	152		
American Society of Mechanical Engineers	11	Boiler and Pipe Lagging.....	237		
Ammunition, Cost of	308	Boiler for Schenectady Motor Car.....	213*		
American Steel Truck.....	299*	Boiler and Steampipe Lagging.....	174		
Angle Shear, Electrically Driven.....	348*	Boilers, Stationary, Gd. Central Station, N. Y.	15*		
Annealing, Dangers in.....	45	Boiler Steel Ingots.....	155*		
Anti-Scalping Bills	93	Boilers, Water-Tube	59		
Anti-Scalping Movement	371	Boilers, Water Tube, in Navy.....	407		
Automatic Signals	16	Bolsters, See Side Bearings.			
Apprentice Boy, The	254	Bolsters, Body and Truck, P. R. R.....	370*		
Apprentices, Education of.....	266	Bolsters, Body, N. P. Ry.....	336*		
Apprentice Problem, The	236	Bolsters, Cast Steel, A. S. F. Co.....	299*		
Armor Plate Problem	93	Bolsters and Side Bearings.....	269		
Armor Plate Tests	342	Bolster, The Simplex	337		
Armstrong's Pipe Machine	141*	Bolt Cutter, Acme Triple.....	379		
Atlantic City Flyer, P. & R. Ry.....	57, 341	Boston & Maine R. R., Concord Shops.	37*, 73*, 109*		
Atlantic Type Locomotive, English.....	257*	Boston & Maine 10-Wheel Locomotive.....	137*		
Auxiliary Engines, Wastefulness of.....	53	Boston Subway, Cost of.....	57		
Axles, Coal Used in Making.....	374	Boston Subway, Finished.....	342		
Axles and Crank Pins, Designs of.....	294*	Brackin Pipe Wrench	67*		
Axles, Driving, Design of.....	211*	Brakebeam, The "Solid".....	102*		
Axles, Driving, Failures of.....	161*	Brakebeam, Strut, Monarch.....	275*		
Axles for Heavy Cars, 100,000 Lbs.....	299*	Brakes, Driving Wheel, Standardized, C. & N. W. Ry.....	4*		
Axles, Nickel Steel, Hollow.....	156*	Brakes, Locomotive Truck	198		
Axles, Pressing Wheels on.....	344	Brake, the Westinghouse High-Speed....	90		
		Brake Forks, Malleable Iron.....	63*		
Babcock & Wilcox Boilers, U. S. S. "Marietta".....	346	Breaking in Two of Freight Trains.....	201		
Baldwin Locomotive Works, N. & W. Compound	181*	Brill Cars and "Perfect" Trucks.....	89*		
Baldwin Locomotive for Columbia University	97	Brill, J. G., Co., Truck.....	240*		
Baldwin Locomotive Works, Steam Motor Cars	135*	Bridge, A Great, in Japan.....	93		
		Bridge, The New East River.....	45		
		Bridges, Inspection of Wooden.....	242		

Car Trucks, New, L. & N. Ry.....	153*	Couplers, M. C. B., Weights, etc.....	349	Fads and Their Cost. By Sanderson....	26
Car Trucks, Lake St. L.....	305*	Couplers, Breakeage of.....	408	Fans, Formula for.....	406
Car Truck, Seaboard Air Line.....	299*	Couplers, Stronger Needed.....	256	Fast Trains, Atlantic City Flyer.....	57, 341
Car Wheels. See Wheels.		Couplers, Strengthening the M. C. B.....	375	Fast Trains, English Opinion of Ameri-	
Car Wheels, Mileage of on C., M. & St. P. Ry.	10	Couplers, Variety of.....	173	can	41
Car Wheel Records, Inaccurate.....	261	Cranes vs. Transfer Tables.....	126, 159	Fast Train on Pan Handle.....	93
Car Wheels and Slide Bearings.....	123*	Crank Pins, Design of.....	153*, 211*	Fast Runs on Union Pacific.....	27
Car Wheels, Thermal Tests of.....	249, 376*	Crank Pins, Stresses and Design.....	124*, 126	Fay, J. A. & Co., Flooring Machine.....	412*
Carbon in Iron.....	58	Crank Pins and Axles, Design of.....	294*	Feed Water, Heated by Live Steam.....	197
Callaway, S. R. Personal Notice.....	217*	Crossover for Wrecks.....	411*	Fire Kindlers, B. & O. S. W. Ry.....	58
Canal, Black and Baltic Seas.....	158*	Crucible for Brazing.....	25*	Firebox Sheets, Cupped.....	417
Carbon, Contents of Piston Rods.....	262*	Cylinder and Boiler Coverings, Tests.....	252*	Firerooms in Tropics.....	276
Cast Iron Car Wheels, Mileage, C., M. & St. P. Ry.	10	Cylinder Fastenings, M. M. Association.....	250*	Flanging of Locomotive Boilers.....	149*
Cast Steel in Locomotive Construction...	230	Cylinder Fastenings for Locomotives....	318	Flooring Machine, Fay & Co.....	412*
Cast Iron, Tests for Hardness.....	307	Cylinder Volumes, W. H. Marshall.....	402	Flue Swage for Locomotive Boilers.....	231*
Cement for Leather Belting.....	274	Cylinders, Grate Areas and Heating Sur-	338	Forney, M. N., on Locomotive Grates....	323*
C., C., C. & St. L. Ry. Consolidation Locomotive.....	167*	face		Forney, M. N., on Tests of Locomotives. 198	
C., M. & St. P. Ry., Shop Engine Condensers.....	87*, 91	Cylinders, N. & W. Compound Locomo-	181*	Forney, M. N., Winans' Camel Engines.....	295*
Chicago & Milwaukee Electric Ry.....	346*	tive		Forney, M. N., Locomotive by.....	398*
C. & E. I. R. R., 80-000 pound Coal Car..	50*	Cylinder Proportions, Henderson.....	389	Forney, M. N., Hayes' Ten-Wheel Loco-	361*
Chicago Pneumatic Tool Co.....	378*, 408	De Laval's High Pressure Boiler.....	6	Forney, M. N., N. Y. R. R. Club.....	411
Chicago Pneumatic Tool Co., Tools of	238, 312*, 317*	Demoulin, Future Development of Loco-	290*	Forsyth, Wm., High Steam Pressure.....	271*
Chicago Storage Battery Railroad.....	100*	motive		Forsyth, Wm., Harwich Shops.....	194*
China, Coal, Resources of.....	339	Derailing Switches, Location of.....	58	Frame Fastenings for Locomotives.....	260*
China, Patents in.....	230	Driving Axle Journals, Lubrication of.....	90, 91*	Front Ends, Short for Locomotives.....	391
China, First Locomotive in.....	232*	Driving Wheel Brakes, Standardized,	4*	Frog and Guard Rail Protection.....	285
Chinese Railways, Existing and Prospective.....	145*, 162	C. & N. W. Ry.....		Gages, Disadvantages of Narrow.....	306
Chemistry, Applied to Railroads. By Dudley. Paints.....	13	Driving Wheel Lathe, Increasing Output of	273	Gas Engine, Diesel.....	265
Chemistry Applied to Railroads.....	119*	Dry Dock at New York.....	58	Gas Engine, Diesel at Munich.....	317
Chemistry Applied to Railroads.....	214	Dry Docks, Dimensions of 10 U. S. Navy	23	Gas Engines for Electric Lighting.....	30
Chronograph, A New.....	274	Dudley, C. B., Chemistry Applied to Rail-	13	Gold Electric Heater, "Alley L" R. R..	88
Cleaning Triple Valves.....	162	roads		Grade Line, Undulating	164
Coal Car Doors, The Johnson.....	276*	Dudley, C. B., Chemistry Applied to Rail-	119*	Grafstrom, Edward, Metric System.....	289
Coal in China.....	339	roads		Grand Trunk, 10 Wheel Locomotives....	136*
Coal Cracker, Hunt's.....	137*	Dudley, C. B., Chemistry Applied to Rail-	214	Grates, Advantages of Small.....	294
Coal, Lignite for Locomotives.....	257	roads		Grate Areas, Heating Surface and Cyl-	338
Coal, Records on Wabash R. R.....	125	Dummy Coupling	368, 372	inders	338
Coal Statistics of Pennsylvania.....	237	Dummy Coupling, Discarded.....	341	Grate Areas, W. H. Marshall.....	402
Coaling Stations, N. P. R. R.....	274	Dust Laying by Oil.....	21	Grates for Locomotives, Small Areas... 260	
Coffin Toughening Process.....	139, 224	Dynamos, Compound Wound Patent....	239	Grates, Locomotive, Coster.....	369
Coke Burning for Boilers.....	231	Economical Locomotives and Track.....	99	Grates, Locomotive, Forney.....	323*
Cole, F. J., Locomotive Design.....	124*	Education of Apprentices.....	266	Gt. Northern Ry., Heavy Locomotive,	
Cole, F. J., on Crank Pins.....	153*, 156*	Efficiency of Steam Engines.....	41	Cards from	84*
Cole, F. J., on Driving Axles.....	202*	Electric Cabs, Paris.....	57	Great Northern Ry., 10 Wheel Locomo-	326*
Cole, F. J., on Tests of Stay Bolts.....	300*	Electric Car Lighting, Axle.....	140*	tive	
Cole, F. J., Piston Rods.....	366*	Electric Lighting from the Axle, Cost of. 325		Great Northern Ry., Mastodon Simple	
Cole, F. J., Springs.....	396*	Electric Lighting, Santa Fe, Limited.... 378		Locomotive	1*, 51*, 84*
Columbia University, Locomotive for....	97	Electric Car Construction.....	52*	Gunn, A Big, for Sandy Hook.....	141
Combustion, Spontaneous in Navy.....	135	Electric Cranes vs. Transfer Tables... 126, 159		Guns, 16-inch Coast Defense.....	286
Como, Electric Exhibition.....	279	Electricity at Crewe Shops.....	152	Gun Fire at Santiago.....	343
"Composite" and Its Field. Paper by Clark	29*	Electric Heaters, Chicago "L" R. R.....	88	Gunn's Running Board Bracket.....	277*
Compressed Air, Wide Range of.....	233	Electric Locomotive, Hoboken Shore R. R.	58	Harris' Air Pressure Pump.....	407*
Compressed Air Hoist, Empire.....	99*	Electric Motors, B. & M. Shops, Concord. 111*, 127		Hayes' Ten-Wheel Locomotive. By M. N. Forney	361*
Compressed Air Painting.....	268	Electric Motors for Machine Tools.....	293	Headlight, Searchlight Attachment.....	347
Compressed Air Riveting.....	406	Electric Motors in Railroad Shops.....	416	Headlight, Circular, C. M. & St. P. Ry... 400*	
Compound Locomotive. See Locomotive.		Electric Motors in Sewer Construction..	58	Heating Surface, Grate Area and Cyl-	338
Compound Locomotive Tests.....	163	Electric Power, Cost of.....	406	inders	338
Compound Locomotives, Stairing Valve Lock	403*	Electric Power, Distribution in Shops... 127		Heating Surfaces, W. H. Marshall.....	402
Compound Locomotive, More Light on..	210	Electric Power for Turning Turrets.....	406	Henderson, G. R., Locomotive Charac-	196*
Compound Locomotive, & Cylinder.....	181*	Electric Power Transmission.....	231	teristics	
Concord Shops, Boston & Maine R. R.	57*, 73*, 109*	Electric Railways, Development of.....	374	Henderson on Cylinder Proportions.....	380
Condensing Plant for Shop Engines.....	37* 91	Electric Railways, Tuttle's Opinion on..	343	High Steam Pressure for Locomotives,	251, 271*
Consolidation Locomotive, B. & M. R.....	296*	Electric Railroad, Storage Batteries on. 59		Hoey Draft Attachment.....	174*
Consolidation Locomotives, Lehigh Valley R. R.....	395*	Electric Storage Battery Railroad.....	100*	Holland Submarine Boat.....	128, 165*
Consolidation, Carnegie Locomotive.....	305*	Elevator Safety Devices.....	308	Hollow Piston Rod.....	51*
Consolidation, M. M. and M. C. B. Association	255	"Elliide," Steam Yacht, Record of.....	22	Hornish Boiler Cleaner.....	413*
Construction of a Modern Locomotive. T. R. Browne.....	79*, 116*, 147*, 187, 329*, 357*	Empire Air Hoist	99*	Horse Power of Locomotives.....	194*
Conventions, M. C. B., and M. M. Associations	255	Employees, Examination of.....	347	Hose, Air Brake, Service Tests of.....	260
Costs of Shop Operations.....	298	Engines and Generators, Westinghouse. 303*		Hose, Failures of Air Brake.....	382
Cost of Locomotive Supplies.....	90	Engineers' Strike in England.....	90	Hose Nipple Cap, The Peerless.....	26*
Coupler Gauge for Worn Couplers.....	416*	English Opinion of American Fast Trains	41	Hose Specifications	127
Coupling Links of Steel.....	164	Engines, Steam Consumption of.....	308	Hose Testing Apparatus.....	175*
Couplers, Drop Tests of.....	162	Exhaust Steam, Waste of.....	164	Hot Boxes and Journal Boxes.....	350
Couplers, Faults of M. C. B. Type.....	304	Expansion Ratios in Steam Engines.....	18	Hydraulic Jointing of Tubes.....	128
Couplers, Height of.....	55, 198, 227	Exposition for New York, Permanent....	285	Hydrogen Liquefied	237

Journal Bearing Keys, Adjustable.....	158*	Locomotives, Electric, for Mines.....	263*	Mine Locomotive, Electric.....	263*
Journal Boxes, Care of.....	247	Locomotive, First in China.....	232*	Metallic Trucks, by Bronner.....	257
Journal Box, Passenger, 4¼ by 8 in.....	248*	Locomotive, Frame Fastenings.....	250*	Metric System, Experience with.....	264
Journals, Burnished Finish.....	337	Locomotive, Future Development of.....	290*	Metric System, Progress of.....	368, 372, 377
"Kaiser Wilhelm der Grosse," Fast Trip by	22	Locomotive Fireboxes, Cupped Sheets.....	417	Metric System, Grafstrom.....	289, 294, 307
"Kaiser Friedrich," Record of.....	274	Locomotive Fireboxes, Turning Over for Repairs	406	Metrology, A Chapter in.....	289
"Kentucky" and "Kearsarge," Battle- ships	157*	Locomotive Grates, Forney.....	323*	Mogul Locomotive, N. Y. Central.....	362*
Key Ways in Driving Axles.....	161*	Locomotive Grates, Small.....	260, 294	Monarch Brake Beam Strut.....	275*
Keys for Journal Bearings, Adjustable.....	158*	Locomotive, Gt. Northern Ry., Indicator Cards	84*	Monitors or Battleships.....	165
Lagging for Steam Heated Surface.....	237	Locomotive, Gt. Northern, England.....	257*	Motive Power Department, Problems of.....	94
Lagging for Locomotive Boilers.....	103	Locomotive, Hayes' Ten-Wheel.....	361*	Motors Applied to Machine Tools.....	293
Lagging for Locomotives.....	307	Locomotive Headlights, Size and Power of	18	Motor Cars, by Baldwins.....	135*
Lagging, Removable, for Locomotives.....	78*	Locomotive, Heilmann.....	32*	Motor Car Boiler, Schenectady.....	213*
Lagging for Boilers and Steamplpes.....	174, 311*	Locomotives, High Pressures for.....	251, 271*	Motor Car, Valve Motion for.....	233*
Lehigh Valley Pushing Locomotive.....	395*	Locomotives, Horse Power of.....	194*	Motor Wagon, Oil, Used in London.....	21
Lighthouse, Large, for Jersey Coast.....	92	Locomotives for Korea, Brooks.....	139*	Movable Sidewalk, Paris Exposition.....	307
Lighthouses in United States.....	273	Locomotive Lagging, Tests of.....	307	National Association of Manufacturers.....	67
Lighting. See Electric.		Locomotive Materials, Stresses in.....	124*	Naval Construction, Uniformity in.....	91
Lighting from the Axle.....	268	Locomotive, Narrow Gauge.....	398*	Naval Vessels, "Kentucky" and "Kear- sarge"	157*
Lignite for Locomotives.....	258	Locomotives, Narrow Gauge for Mexico.....	333*	Navy and the War, Sampson.....	375
Liquor, Men Discharged for Using.....	279	Locomotive, N. Y. C. Mogul.....	362*	Navy at Santiago.....	272
Locomotives, Eight-Wheel, for Japan.....	105*	Locomotive, N. & W., Two-Cylinder Compound	181*	Nickel Steel Axles and Crank Pins.....	156*
Locomotive, Eight-Wheel, for Japan.....	48*	Locomotive Operation, N. P. Ry.....	400	Nickel Steel for Crank Pins.....	155
Locomotive, Ten-Wheel Passenger, Gt. N. Ry.	326*	Locomotive, Pittsburg, Largest Built.....	365*	Nickel Steel Fireboxes.....	164
Locomotive, Ten-Wheel Passenger, Gd. Trunk	136*	Locomotives, Pooling of.....	54, 63, 129	Nickel Steel for Marine Boilers.....	92
Locomotive, Ten-Wheel Compound, B. & M. R. R.	137*	Locomotives, Pulling Capacity.....	406	Niles Tool Works, Milling Machines.....	235*
Locomotives, Ten-Wheel, N. P. Ry.....	65	Locomotive, Purdue Laboratory, New.....	7*	Niles Tool Works, Railway Clubs at.....	88
Locomotive, Ten - Wheel Passenger, Southern Ry.	82*	Locomotive with Piston Valves, N. & W. Ry.	38*	Norfolk & Western, Two-Cylinder Com- pound	181*
Locomotive, Ten-Wheel, M. P. Ry.....	381	Locomotives, Reconstruction of.....	216	Northern Pacific Ry., 70,000-lb. Coal Car..	46*
Locomotive, Ten-Wheel, Wisconsin Cen- tral	192*	Locomotives, Reversing to Stop Quickly.....	57	Northern Pacific Ry., 100,000-lb. Steel Car.....	335*
Locomotive, Consolidation, B. & M. R.....	296*	Locomotive Runs, Long.....	406	Northern Pacific Ry., Locomotive Oper- ation	400
Locomotive, Consolidation Pusher for Le- high Valley.....	395*	Locomotive Runs, Long Distance.....	274	Northern Pacific, Coaling Station.....	274
Locomotives, Consolidation, O. & L. C. R. R.	103*	Locomotives in Russia, Number of.....	57	Northern Pacific, Weed Burner.....	345*
Locomotive, Consolidation, C., C., C. & St. L.	167*	Locomotive Shops, L. & Y. Ry.....	194*	Ogdensburg & Lake Champlain Locomo- tive	103*
Locomotive, Consolidation, Mexican Cen- tral	31	Locomotive Smokebox Arrangement, Pur- due	8*	Oils, Maunene's Test for.....	214
Locomotive, Consolidation, Carnegie.....	364*	Locomotive Smoke Boxes, Short.....	391*	Oil Fuel in English Navy.....	308
Locomotive, Mastodon Simple, Gt. North- ern Ry.	1*, 51*	Locomotive Statistics, Ton-Mile.....	211	Oil as Scale Remover.....	369
Locomotives, American, for Russia.....	129	Locomotive Stay Bolts, Bending Tests.....	300*	"Oregon," Wonderful Trip of.....	308
Locomotive, Amount of Materials Used in	69	Locomotive, Superheater for.....	344*	"Oregon," Guns on the.....	342
Locomotive Boilers, Large.....	269	Locomotive Tenders, in England.....	93	Packing for Rods.....	376*
Locomotive Boiler Cleaner, Hornish.....	413*	Locomotives, Tonnage Rating of.....	65*, 85, 277	Paints, Lead vs. Zinc.....	417
Locomotive Boiler Lagging.....	103	Locomotives and Trucks, Economy.....	99	Paint Tests in New York City.....	259, 272*
Locomotive Boilers, Removable Covering.....	78*	Locomotive Truck Brakes	198	Painting by Compressed Air.....	268
Locomotive Boiler, Gt. Northern Mas- todon	3*	Locomotives in the United States.....	375	Painting Cars, Output of Shops.....	93
Locomotive Boiler, Purdue Locomotive..	7*	Locomotives, Winans' Camel.....	205*	Painting, Saving on Tenders.....	383
Locomotive Boiler Tests, Duration of, 54, 64		Logging Cars, C. & W. W. Ry.....	406	Passengers Carried on Chicago Elevated Roads	406
Locomotives, Baldwin, for Soudan.....	138*	Long Locomotive Runs.....	274, 406	Patents, Report for 1897.....	342
Locomotive Characteristics	196*	Long & Allstatter, Angle Shear.....	348*	Patent Laws of Austria.....	274
Locomotives for China, Rogers Locomo- tive Works	12*	Lubrication of Driving Journals.....	90, 91*	Patents, Report of Commissioner.....	93
Locomotives, Comparative Tables of Di- mensions	296	Lumber Specifications for Cars.....	268	Patents in China	230
Locomotive, The Composite and Its Field	29*	Machine Shop, The. By T. R. Browne.....	329*	Peerless Hose Nipple Cap.....	26*
Locomotives, Compound Starting Valve Lock	493*	Machine Tools, Importance of Good.....	54	Pensions to Employees.....	209
Locomotives, Compound, Coal Records of	44	Machine Tools, Specifications for.....	21	Pennsylvania Limited	69
Locomotives, Compound, in Russia.....	57	Malleable Iron Brake Forks.....	63*	Pennsylvania R. R. Report.....	128
Locomotives, Comparative Tests of.....	148	Manufacturers' Advertising Bureau.....	25	Philadelphia & Reading Starting Valve.....	403*
Locomotive, Construction of a Modern, 79*, 116*, 147*, 187*, 329*, 357*		Magnolia Metal Co., Suit of.....	241	Philadelphia & Reading "Flyer".....	341
Locomotive Construction, Cast Steel in..	230	Manhattan Elevated, Electric Traction..	58	Philadelphia & Reading, Shop Notes.....	169
Locomotive, Cylinder Fastenings.....	318	Mannesman Tube Tested.....	58	Piece Work	306, 343
Locomotive, Cylinder Proportions.....	389	Marine Engines, H. M. S. "Terrible".....	374	Piles, Wooden, Life of.....	275
Locomotive Cylinders, Purdue Locomo- tive	7*	Marshall, W. H., on Statistics.....	211	Pipe Wrench, The Brackin.....	67*
Locomotive Design, Driving Axles.....	202*	Marshall, W. H., Grate Areas, etc.....	402	Pipe Machine, Armstrong's.....	141*
Locomotive Design, Crank Pins.....	153*, 124*	Massachusetts Institute of Technology, New Building	94	Piston Rods, Breakage of.....	262*, 340, 369*
Locomotive Design, Piston Rods.....	366*	Master Car Builders' Association, Pro- ceedings	219	Piston Rods, by Cole.....	366*
Locomotive Design, Springs.....	396*	M. C. B. & M. M. Associations, Consoli- dation	381	Piston Rod, Hollow	51*
Locomotive, Double Stack, T. P. & W....	98*	Master Car Builders' Convention.....	69, 94	Piston Rods, Steel for.....	262*
Locomotive, Electric, Hoboken Shore R. R.	58	M. C. B. Couplers, Faults of.....	304	Piston Stroke, Henderson.....	383*
		M. C. B. Couplers, Stronger Needed.....	256	Piston Valves, Norfolk & Western Ry... 38*	
		M. C. B. Designs of Steel Cars, Criti- cised	19	Piston Valves, Gt. Northern Locomotive 3*	
		M. C. B. Association, Important Reports.....	236	Piston Valve, Packing Rings for.....	85*
		M. C. B. Standards in Repairs.....	17	Piston Valves, W. C. Ry. Locomotive.....	190*
		Master Mechanics' Association, Proceed- ings	223	Pittsburg Locomotive, Largest Built.....	365*
		M. M. and M. C. B. Associations, Con- solidation	255	Pittsburg Locomotive Works, Locomo- tive	296*
		M. M. Association, Committees.....	347	Pneumatic Chain Hoist.....	408*
		Materials, Working Stresses of.....	124*	Pneumatic Hammer, Chip from.....	317*
		Mechanical Draft	297	Pneumatic Riveting on Large Scale.....	378*
		Milling Machines, Niles Tool Works.....	235*	Pneumatic Riveting.....	406
		Mendenhall, on Metric System.....	294	Pneumatic Tools at M. C. B. Convention.....	238*
				Pneumatic Tools	312*
				Pneumatic Tubes on Brooklyn Bridge...	295
				Pomeroy, L. R., Coffin Process.....	139

Pomeroy, L. R., Axles and Crank Pins.....	211*	Signals, Block and Traffic.....	92	Ties, Economy in Burning.....	273
Pooling Locomotives.....	54	Signaling, Lecture by F. A. Delano.....	128	Tie Plates, Roadmasters' Association.....	348
Postal Cars, Chicago & Alton.....	43*	Signaling, Progress in.....	374	Timber Tests, U. S. Government.....	261, 272
Postal Cars in South America.....	237	Signaling, Uniformity in.....	337	Timber, Strength of.....	229
Prizes for Engineers and Firemen.....	94	Signaling on Trains in England.....	309	Tonnage Rating.....	65*, 85, 227
Premiums to Engine Men.....	201	Signaling Club, Meeting of.....	69	Ton vs. Engine, Mile Statistics.....	211
Projectile, An Oil Distributing.....	22	Signaling, Club.....	115	Tools, Improved, for R. R. Shops.....	316
Providence Station.....	374	Signal, The Distant.....	372	Tools, Modern, Necessity for.....	306
Purdue University, Lectures.....	88, 133	Signal Plant, Gt. Eastern Ry.....	57	Tool Rack for Forge Shops.....	230*
Purdue University, G. W. Rhodes at.....	105	Signal Poles, Iron, C., M. & St. P. Ry.....	292*	Torpedo Boat, High Speed.....	374
Purdue University, New Laboratory Locomotive.....	74*	Simplex Truck Bolster, C. & O. Ry.....	337*	Toucey, J. M., Obituary.....	333
Q. & C. Company Shop Saws.....	415*	Shops, Improved Tools for.....	316	Track Tanks, Advantages of for Freight Service.....	22
Q. & C. Scott Boiler Feeder.....	48*	Shop Operations, Costs of.....	298	Track Tanks for Locomotives.....	340, 412
Q. & C. Co., Emergency Crossover.....	411*	Smart, R. A., Compound Locomotive Tests.....	163*	Trains, Breaking in Two of.....	201
Quayle, Business Problems, M. P. Dep't.....	94	Smoke Prevention, Franklin Institute.....	58	Train, Fast, on P. C. C. & St. L. Ry.....	93
Railway Club Reports.....	161	Smoke Boxes, Short.....	391*	Train, Heavy, on C. & E. I. R. R.....	274
Railway Clubs, What They May Do.....	380	Snow Car, B. & M. R. R.....	93	Trains, Punctuality of American.....	123
Railway Clubs at Niles Tool Works.....	88	Snow, T. W., Opinion of Track Tanks.....	412	Train Service Improvement in England.....	342
Rails, Depression of by Locomotives.....	164	Southern Railway, Ten-Wheel Passenger Locomotive.....	82*	Train Signals in England.....	309
Rail Joint, Webb's Patent.....	32*	"Solid" Brakebeam.....	102*	Trains, Speed of, L. & N. W. Ry.....	342
Rail Joint, Suspended or Supported.....	241	Speed and Pulling Capacity of Locomotives, Henderson.....	389	Transfer Tables vs. Cranes.....	126, 159
Railway Signaling Club.....	115	Springs for Freight Car Trucks.....	248*	Traveling Engineers' Association.....	325
Railroad Men in Other Fields.....	210	Springs, Design of, by F. J. Cole.....	396*	Thermal Tests of Wheels.....	249, 380
Rail Rolling, Rapid.....	411	Spring Plank and Spring Seat for Trucks.....	104*	Triple Valves, Cleaning of.....	69, 162
Randolph, L. S., Getting Work Out of Men.....	90	Stack, Double for Locomotives.....	98*	Trolley Car Accidents.....	19
Rapid Transit in New York.....	94	Standard Trucks.....	257	Trolley Competition.....	164
Receiver, N. & W. Compound Locomotive.....	181*	Standpipe, Sheffield.....	97*	Truck, See Car, Locomotive and Tender.	
Refrigerator Car, Brine Dripping from.....	246*	Station Plans, Prizes for.....	129	Truck Bolster, Simplex.....	337*
Repair Ship Vulcan.....	401	Staybolt, Failures and Explosion.....	275	Truck, The Brill "Perfect".....	89*
Resistance of Locomotive and Tender.....	225	Staybolts and Fireboxes.....	371	Truck, J. G. Brill Co.....	240*
Reversing Locomotives for Quick Stops.....	57	Staybolts, Fitting of.....	151	Truck Brakes, Locomotive.....	198
Rhodes, G. W., on Economical Locomotives.....	99	Staybolts, Recent Improvements in.....	121*	Trucks, Coal Cars, L. S. & M. S. Ry.....	184*
Richmond Locomotive Works, C., C., C. & St. L. Locomotive.....	167*	Staybolts, Tests of.....	300*	Trucks, Combination Spring Plank for.....	104*
Richmond Locomotive Works, Southern Ry. Locomotive.....	82*	Steam Consumption of Engines.....	308	Truck, Lake St. L. for Motors.....	305*
Riveting, Pneumatic.....	406	Steam Engine Efficiency, Terms of.....	41	Trucks, New Freight, L. & N. Ry.....	153*
Rivet Furnace.....	416*	Steam Heat Conduit, Flexible.....	376	Truck, Standard Freight, Seaboard Air Line.....	299*
Rockwood's Compound Engine, Ratio 7 to 1.....	18	Steam Heating of Concord Shops.....	113	Trucks, Standard.....	257
Rope Driving, Continuous.....	43	Steam Motor Cars by Baldwin's.....	135*	Trucks, Tests of on C. & O. Ry.....	387
Rope Drive in Railroad Shop.....	45*	Steam Pipe Coverings.....	311*	Tunnel Under East River, New York.....	22
Rope Railways, Aerial.....	231	Steam Pipes, Losses from Long.....	237	Turbine, Boiler for, De Laval.....	302*
Rubber Hose Specifications.....	127	Steam Piping, B. & M. R. R. Concord Shops.....	110*	Turbines, Steam, Speed of.....	85
Running Board Bracket, Gunn's.....	277*	Steam Pipe and Boiler Lagging.....	174, 237	Turpentine, Tests of, Dudley.....	119*
Safety Appliance Law, Extension of.....	18	Steam Power, Reduction in Cost of; Dean.....	31	Union Pacific, Fast Runs on.....	27
Sague, J. E., on Cast Steel.....	230	Steam Pressure, High for Locomotives, 251, 271*		Vaughan, H. H., Steel Car.....	101*
Sanderson on "Fads and Their Cost".....	26	Steam Pressure, High, Marine.....	273	Valve Motion, Baldwin Steam Motor Cor.....	233*
Sand Blast for Cleaning Tenders.....	58	Steam Pressures, Marine, Rising.....	92	Valves, Piston, W. C. Ry., Locomotive.....	190*
Salt Water Drippings, Prevention of.....	246, 282	Steam Power, Low Cost, Warren, R. I.....	237	Valves, Triple, Cleaning of.....	162
Sawing Machines, Q. & C. Co.....	415*	Steamship, Record of Fast Trip.....	237	Vestibules Save Telescoping.....	342
Santiago, The Navy at.....	272	Steamship Record, "Kaiser Friedrich".....	274	Vulcan, Repair Ship.....	401
Schenectady Locomotive Works, N. Y. C. Mogul.....	262*	Steam Superheating, Schmidt System.....	172*	Waitt, A. M., Journal Bearing Key.....	158*
Schenectady Locomotive Works, Locomotives by.....	103*, 137*	Steam Turbines, Speed of.....	85	Waitt, A. M., on Side Bearings.....	338
Schenectady Locomotive Works, Purdue Locomotive.....	7*	Steam Turbine.....	128	Warren's Double Stack for Locomotives.....	98*
Schenectady Motor Car Boiler.....	213*	Steam Yacht "Ellide," Record of.....	22	Warships, Large, in English Navy.....	227
Schenectady Narrow Gage Locomotive.....	333*	Steel for Axles, Pins and Rods.....	372	Warships, Steaming Radius of.....	275
Schickle, Harrison & Howard, Truck Casting.....	104*	Steel, Dangers in Annealing.....	45	Water Column, Sheffield.....	97*
Schooner, Largest Built.....	374	Steel Cars, Construction of.....	6	Water Purifying Plant.....	283*
Sellers' Feed Hose Strainer.....	267*	Steel Cars, Advantages of.....	55	Water Stations for Rapid Discharge.....	403
Sheffield Standpipe.....	97*	Steel Cars, A Correction.....	141	Water Stations.....	128
Ships, Fires in Naval.....	135	Steel Car, Frame for.....	101*	Water Tube Boilers, Melville's Report.....	22
Shops and Good Equipment.....	126	Steel Car Frames.....	209, 247	Water Tube Boilers on Passenger Steamer.....	22
Shop Notes, Philadelphia & Reading.....	169	Steel Cars, Large.....	86	Water Tube Boilers, U. S. S. "Marietta".....	346
Shops, Boston & Maine R. R., at Concord.....	37*, 73*, 109*	Steel Cars, Neglected, by M. C. B. Association.....	236	Water Tube Boilers, Low Water in.....	406
Shops, Cranes vs. Transfer Tables.....	126	Steel for Coupling Links.....	164	Water Tube Boilers in Navy.....	407
Shop Engines, Condensing Plant for.....	87*, 91	Steel Ingots for Boiler Plates.....	155*	Weed Burner, N. P. Ry.....	345*
Shops at Horwich, L. & Y. Ry.....	194*	Stillman, Water Purifying Plant.....	283	Westinghouse Apparatus, Boston Station.....	173
Siberian Railroad.....	211	Stone Crusher, B. & O. S. W. Ry.....	16*	Westinghouse, Electric Transmission Plant.....	347
Siberian Railroad, New Train.....	349	Storage Batteries in Chicago.....	59	Westinghouse Engines and Generators.....	303*
Side Bearings for Cars, M. C. R. R.....	339*, 394*	Storage Battery Railroad.....	100*	Wheels, see Car Wheels.	
Side Bearings for Cars, A. M. Waitt.....	338	Strainer for Feed Hose.....	267*	Wheels, Car, Mileage of, C. M. & St. P. Ry.....	10
Side Bearings for Cars.....	229, 306, 310	Strike of Engineers in England.....	90	Wheels for 100,000-lbs. Cars, Tests.....	376*
Side Bearings and Bolsters.....	269	Submarine Boat, Holland.....	165*	Wheel Irons and Thermal Test.....	380
Side Bearings and Wheel Wear.....	123*	Submarine Boat, The Raddatz.....	17*	Wheels, Pressing on Axles.....	344
Signals, Automatic.....	16	Superheater for Locomotives.....	344*	Wheel Records, Inaccurate.....	261
Signals, Block, Strongly Indorsed.....	92	Superheating, Schmidt System.....	172*	Wheels, Wear of, and Side Bearings.....	123*
		Susemihl-Torrey Car Side Bearing.....	339*	Winans Camel Engines.....	206*
		Switzerland, Cheap Fares in.....	349	Wire, from Niagara Bridge.....	94
		Technical Papers, How to Use.....	256	Wood's Car Seal.....	309*
		Telephone, Effect of on Train Service.....	308	Wood Working Machinery.....	412*
		Temperature of Firerooms, High.....	276		
		Tender Truck, Player's.....	28*	Yellow Pine Lumber.....	6
		Tests of Compound Locomotive.....	163*	Y. M. C. A., Influence in Railroad Work.....	21

AMERICAN ENGINEER CAR BUILDER AND RAILROAD JOURNAL.

JANUARY, 1898.

CONTENTS.

ILLUSTRATED ARTICLES:	Page	EDITORIALS:	Page
Powerful Simple Locomotives, Gt. Northern Ry.	1	Y. M. C. A. Influence in Railroad Work	20
Standardized Driver Brakes	1	Specifications for Machine Tools	21
New Laboratory Locomotive, Purdue University	7	MISCELLANEOUS:	
Locomotives for China	12	A Double Deck Steel Electric Car	4
Belpaire Stationary Boilers, Grand Central Station	15	Construction of Steel Cars	6
Stone Crusher, B. & O. L. W. Ry.	16	De Laval's High-Pressure Steam Boiler	6
Raddatz Submarine Boat	17	Yellow Pine Car Lumber	6
A New Brazing Crucible	25	Warning to Inventors	6
The Peerless Hose Nipple Cap	26	Mileage of Cast-Iron Wheels	10
The Player Metallic Truck	28	American Society of Mechanical Engineers	11
The "Composite" and its Field	29	Chemistry Applied to Railroads	13
Webb's Rail Joint	32	1898 Conventions at Saratoga	15
New Heilmann Locomotive	32	Automatic Signals	16
EDITORIALS:		M. C. B. Standards in Repairs	17
American Society of Civil Engineers	18	Engineering Notes	21
The Power of Locomotive Headlights	18	Publication Notices	24
Ratio of Expansion in Compound Engines	18	Fads and their Cost	26
Safety Appliance Act	18	Fast Runs on the Union Pacific	27
Trolley Car Accidents	19	Locomotive Building in 1898	30
Steel Freight Cars, M. C. B. Designs	19	Consolidation Locomotive, Mexican Central Ry.	31
		Reduction in Cost of Steam Power	31
		A Simple of Railroad Air Equipment and Manufacturing	32
			34

Powerful Simple Locomotives for the Great Northern Railway.

Two locomotives of extraordinary power, weight and size have recently been delivered to the Great Northern Railway and through the courtesy of Mr J. O. Pattee, Superintendent of Motive Power of the road, and the Brooks Locomotive Works, the builders, we are enabled to present illustrations and a description of the interesting details of the design. The importance of the subject renders it inadvisable to attempt to show all of the details in a single article; we select the boiler and the cylinders as the most important features and will reserve others for the following issue. We understand that these engines are to be used in specially exacting service on one of the heavy grade divisions of the road and that they were designed with special reference to the work on that grade. The design is one of the most interesting ever produced and it is sure to attract attention from railroad men the world over. These locomotives are the heaviest ever built, with the exception of combinations such as the Johnstone Mexican Central engines, built by the Rhode Island Locomotive Works, which are really two locomotives in one. The specially heavy engines for the St. Clair Tunnel and the Class "S" of the Erie are in many respects comparable with the new Great Northern type, and for reference we give some of their characteristics. The weights of the Erie engine are taken from the railway company's figures:

	St. Clair Tunnel.	Erie Class "S."	Great Northern.
Cylinders	22 by 28 inches	16 by 27 by 28 inches	21 by 34 inches
Boiler pressure	160 pounds	180 pounds	210 pounds
Boiler diameter	74 inches	78 inches	78 inches
Driving wheels	50 inches	50 inches	55 inches
Heating surface	2,352 square feet	2,170.9 square feet	3,280 square feet
Grate area	38.6 square feet	89.6 square feet	31 square feet
Weight on drivers	180,000 pounds	173,700 pounds	172,000 pounds
Total weight	180,000 pounds	200,350 pounds	212,750 pounds

Among the chief features to be mentioned, the first is the cylinders, which are 21 by 34 inches in size. The stroke is longer than ever before used in locomotive practice so far as we are able to learn. These cylinders demand an enormous steam-producing capacity, and this is furnished in the shape of a boiler of the Player patent, improved, conical connection, Belpaire type, having a total heating surface of 3,280 square feet, working under a pressure of 210 pounds per square inch. The diameter of the smallest ring of the boiler is 78 inches and the largest is 87½ inches. The firebox is above the frames and is 10 feet 4 inches long by 3 feet 4½ inches

wide, the depth at the front being 86½ inches and at the back 79 inches. The grate area is 31 square feet and the ratio between the heating surface and the grate area is 96 to 1. The tubes furnish 3,045 square feet of heating surface, and it is noted that they are 376 in number, the diameter being 2½ inches and the length 13 feet 10½ inches over the sheets.

These dimensions are accompanied by great weight, the total weight in working order being 212,750 pounds, of which 172,000 pounds are on the drivers and 40,750 pounds on the truck. The total weight of engine and tender is 308,750 pounds. The weight upon each driving wheel is 21,500 pounds and these wheels are 55 inches in diameter and of cast steel.

An interesting treatment of the valve problem would naturally be expected in connection with these cylinders and the high steam pressure. The valves are of the piston type and are balanced. We shall not do more at this time than to call attention to the very large exhaust port and to the arrangement of the valve, whereby it runs in hollow sleeves. The drawing shows the construction, and further comments will be made in regard to this construction. The piston-rods are hollow and extended. The chief general dimensions are given in the following table:

Gauge	4 feet 8½ inches
Simple or compound	Simple
Kind of fuel to be used	Bituminous coal
Weight on drivers	172,000 pounds
" truck wheels	40,750 pounds
" total, engine	212,750 pounds
" tender, loaded	96,000 pounds
" total, engine and tender	308,750 pounds
Wheel base, total, of engine	26 feet 8 inches
" driving	15 feet 10 inches
" total, engine and tender	51 feet 3¼ inches
Length over all, engine	31 feet 4 inches
" total, engine and tender	61 feet 1¾ inches
Height, center of boiler above rails	9 feet 5 inches
of stack above rails	15 feet 6 inches
Heating surface, firebox	335 square feet
" tubes	3,015 square feet
" total	3,280 square feet
Grate area	31 square feet

WHEELS AND JOURNALS.

Drivers, number	8
" diameter	55 inches
" material of centers	Cast steel
Truck wheels, diameter	39 inch centers cast steel spake
Journals, driving axle, size	9 inches by 11 inches
" truck	5½ by 12 inches
Main crank pin, size	Main rod bearing, 6¼ inches by 6¼ inches; coupling rod bearing, 7¾ inches by 5 inches; wheel fl.
	7¾ inches diameter by 7½ inches long

CYLINDERS.

Cylinders	21 by 34 inches
Piston rod, diameter	1¼ inches
Kind of piston rod packing	Jerome
Main rod, length center to center	8 feet 10 inches
Steam ports, length	1½ inches
" width	1¾ inches
Exhaust ports, length	50 inches
" width	9 inches
Bridge, width	6¾ inches

VALVES.

Valves, kind of	Piston
" greatest travel	6¼ inches
" outside lap	1½ inches
" inside lap or clearance	1¾ inches clearance
" lead in full gear	0
" constant or variable	Variable

BOILER.

Boiler, type of	Player Patent Improved Conical Connection Belpaire
" steam working pressure	210 pounds
Boiler, material in barrel	Steel
" thickness of material in barrel	7½ and 1½ inches
" diameter outside, smallest	78 inches
" largest	87½ inches
Seams, kind of horizontal	Sextuple lap
" circumferential	Triple lap
Thickness of tube sheet	¾ inch
Crown sheet stayed with	Improved system direct stays
Dome, diameter	30 inches

FIREBOX.

Firebox, type	Horizontal over frames
" length	10 feet 4 inches
" width	3 feet 4½ inches
" depth front	88½ inches
" back	79 inches
" material	Steel
" thickness of sheets	¾ inch
" brick arch	None
Mud ring, width, front, 4 inches; sides, 4 inches; back, 4 inches; thickness, 4 inches; riveting, double	
Water space at top, front	4 inches; sides, 7 inches; back, 6 inches
Grate, kind of	Cast iron rocking

TUBES.

Tubes, number	376
" material	Charcoal iron
" outside diameter	2½ inches
" length over sheets	13 feet 10½ inches

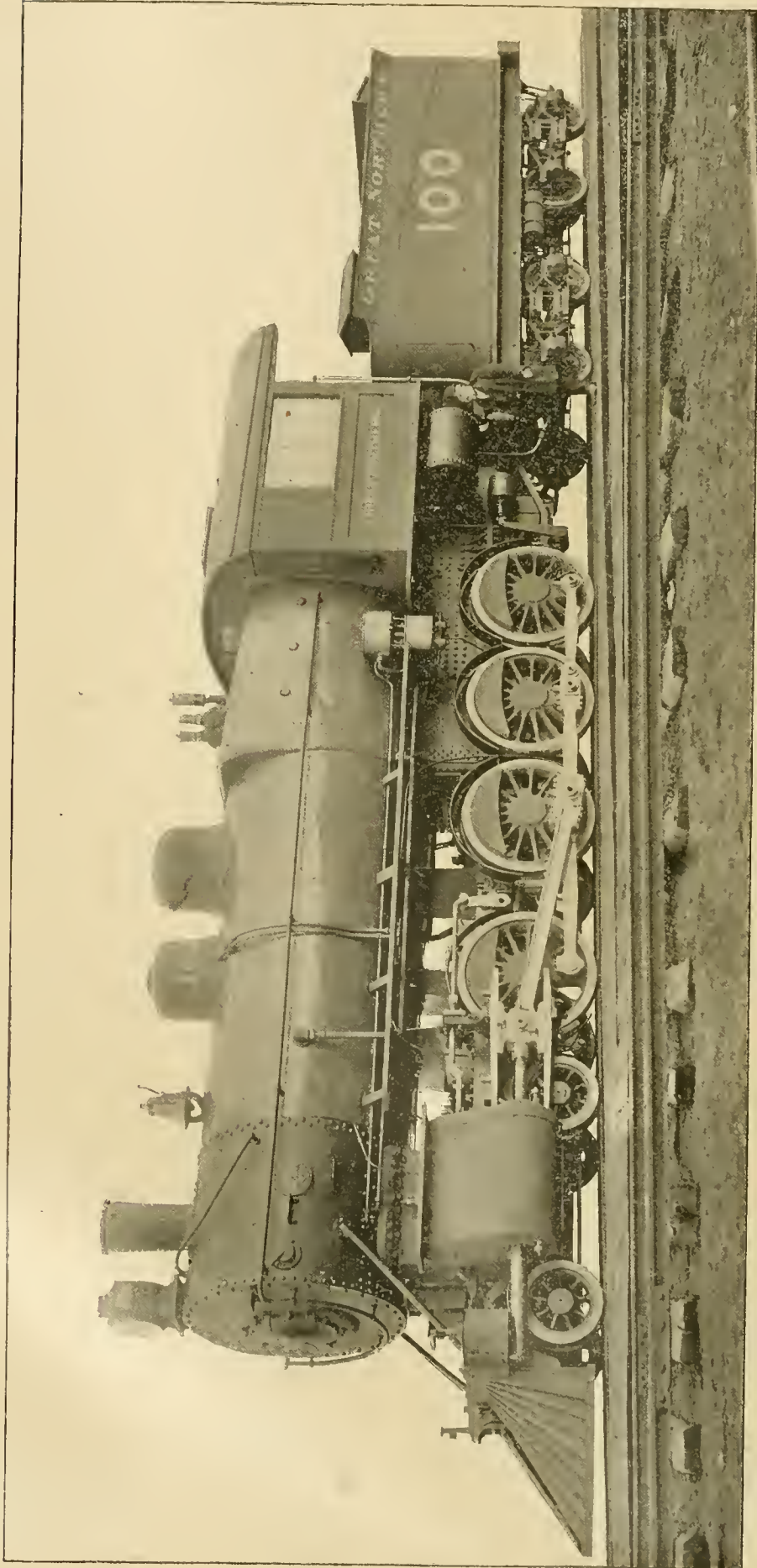

POWERFUL TWELVE-WHEEL SIMPLE LOCOMOTIVE FOR THE GREAT NORTHERN RAILWAY.

Mr. J. O. PATTEE, Superintendent of Motive Power.

THE BROOKS LOCOMOTIVE WORKS, Builders.

SMOKEBOX.	
Smokebox, diameter outside.....	81 inches
length from flue sheet.....	67 inches
Bell's spark arrester.....	
TENDER.	
Type.....	swivel trucks
Tank capacity for water.....	1,670 gallons
Coal capacity.....	10 tons
Thickness of tank sheets.....	$\frac{3}{8}$ inch and $\frac{1}{2}$ inch
Type of under frame, wood or iron.....	10-inch channel steel
Type of truck.....	Four-wheeled, Great Northern standard
Truck, with swinging motion or rigid bolster.....	Rigid
Type of truck spring.....	One-half elliptical
Diameter of truck wheels.....	33 inches
Diameter and length of axle journals.....	$4\frac{1}{4}$ inches by 8 inches
Distance between centers of journals.....	6 feet 3 inches

Chicago. The car is to be used on the Chicago General Railway in its suburban service, the clearance being insufficient to permit its use on the downtown lines. This car is entered at the center by means of a low platform dropped between the trucks which permits of easy entrance from the ground, and divides the car at the center in such a way as to prevent drafts of air from passing through the car lengthwise, an exceedingly important feature for winter use. The car has no end platforms, but is enclosed, these portions being used for seats for passengers. The motors are controlled from the ends of the upper deck. The seats except at the

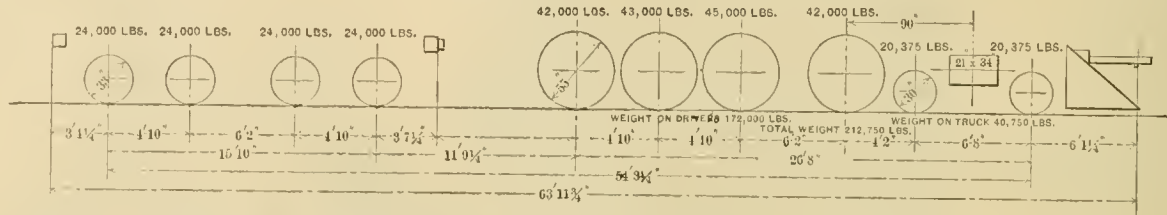

Twelve-Wheel Locomotive, Great Northern Railway—Diagram Showing Weights.

NAMES OF MAKERS OF SPECIAL EQUIPMENT.	
Wheel centers.....	Pratt & Letchworth
Tires.....	Krupp
Axles.....	Pennsylvania Steel Company billets
Truck wheels.....	Tender, Krupp No. 4 engine, B. L. W.
Sight-feed lubricators.....	Nathan
Safety valves.....	Crosby
Boiler covering.....	Sall Mountain asbestos
Sanding device.....	One pair Leach double sanders
Injectors.....	New Nathan and Monitor O. S.

ends of the lower deck are arranged longitudinally and access to the inside is had from the central corridor, which also leads to two stairways for the upper deck. This deck may be enclosed in the winter and for the summer it may be left open, making it the most attractive part of the car.

The lower deck seats 36 passengers and the upper deck seats 44, while the capacity, including standing room, is placed at 200 passengers. The car weighs 20,000 pounds, and the entire construction, except the finish, the sash frames and rests, is of steel. The length over the sills is 34 feet and the width over the sills is 7 feet. The length over all is 35 feet 8 inches and the total width is 7 feet 11 1/2 inches; the height is 13 feet 6 inches. The motor equipment consists of four 40 horse-power Westinghouse motors, one on each axle, but it is understood that only two of the motors are required in the operation of the car. Except as regards the steel construction this car resembles those designed and built by Mr. Pullman which are running at Saratoga and at Jamestown, N. Y.

Standardized Driver Brakes C. & N. W. Ry.

On roads having a large number of locomotives divided into comparatively small classes, as was natural under the methods of ordering locomotives a number of years ago, the large number of repair parts that must be carried in stock for the various shops has become burdensome, and it has recently been seen to be a source of great expense which has been the subject of considerable study in the effort to simplify the designs, to reduce the number of the parts and permit of using one pattern for a number of locomotives. On the Chicago & Northwestern Railway this work has been carried out in regard to smokestacks, pilots, cylinder-heads and driving-wheel brakes to the great reduction in the number of castings that must be held in stock at all times for regular repairs and for emergencies.

In taking up the driving wheel brakes it was found that the variation in the distances between the wheels and the different forms of brackets for hanging the brakes necessitated quite a number of cams and levers and a new design was made with adjustable links whereby the fewest possible castings would serve and at the same time give as nearly as possible the correct shape of the cams. The new work was all made in the form of steel castings to replace the expensive forgings formerly employed and experiments were made to secure the best proportions of the levers in cast steel in order to insure sufficient strength. It was found that with the ordinary rigging the braking power varied to a great extent as the shoes wore down and this was another reason for providing facilities for adjustment in the new designs.

In order to enable the adjustment to be correctly made rules were prepared and tabulated to apply to all classes of engines. Fig. 1 shows the arrangement of the brake, and it will be noticed that the top ends of the shoes are held away from the wheels,

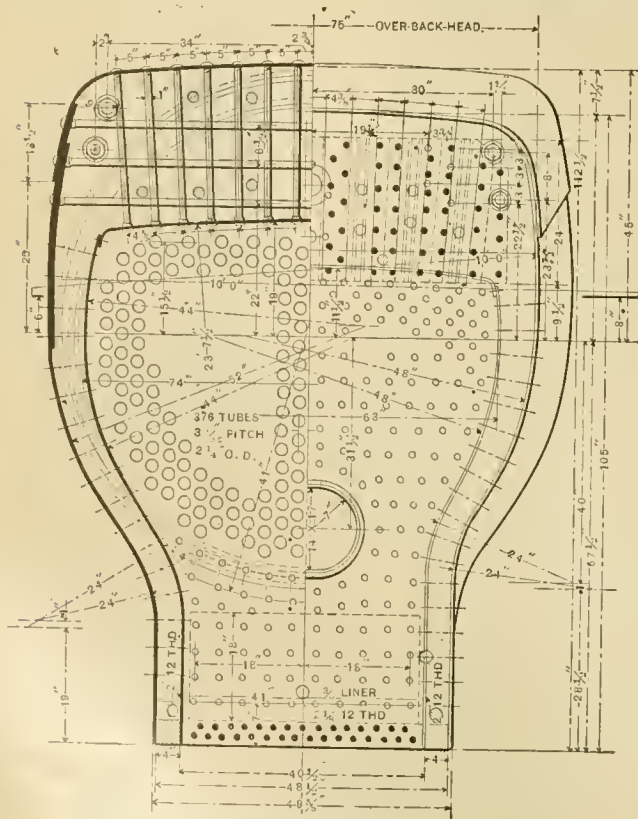

Section Through Firebox.

Driver brake equipment.....	New York
Tender.....	New York
Tender brakebeam.....	Monarch
Air pump.....	New York No. 2
Steam gauges.....	Crosby
Whistle.....	Curran Chime
Headlight.....	Glazier Headlight Company
Springs.....	French
Metallic packing.....	Jerome

A Double Deck Steel Electric Car.

An interesting suburban electric car built of steel and having two decks for passengers has been built by the Wells & French Company to the order of the C. L. Pullman Car Company, of

when released, by spring rods which pass through the brake levers. The brakes are of the push-down type and to adjust them the following rule is given: Divide the distance "A" (Fig. 1) in inches, by the figure opposite the class of the engine" as given in the table, and the result will be the distance "B," or the height of the point of contact of the cams above a line drawn through the pin connections to the levers. The distance "A" is to be measured when the shoes are in contact with the tires. The cams were designed for 8-inch cylinders and to use 70 per cent. of the brake power and 50 pounds air pressure. The cams given do not correspond exactly to the formula because it was found

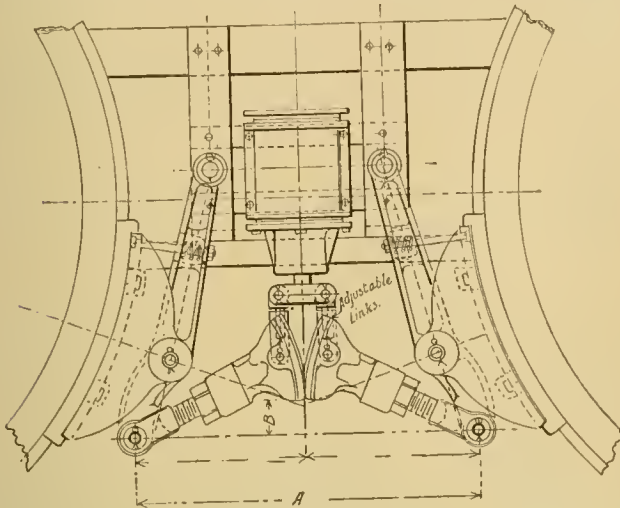

Fig. 1.

desirable to use a smaller number of them than this would call for and the form was modified slightly so as to utilize each cam for a maximum number of engines, but not enough to bring the leverage far out of the way.

The levers were worked out by the plan shown in Fig. 2, in which the following relations obtain:

A = length of lever from center of suspension to center of brakehead connection.

B = length of lever from center of brakehead to center of cam connection.

C = length of lever from center of suspension to center of cam connection.

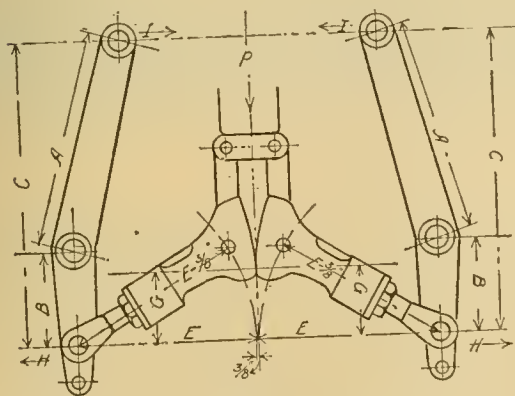

Fig. 2.

D = brake power.

E = distance from center of cam connection to center line of piston rod.

E - 3/8 inch = radius of link pin travel.

G = distance from point of contact of cams to a horizontal line drawn through the centers of cam connections.

H = pressure at point of cam connection.

I = pressure at point of suspension.

P = cylinder pressure multiplied by area of piston.

$$I = \frac{B \times D}{C} \quad D = \frac{P \times E \times C}{2 \times A \times G}$$

$$H = \frac{A \times D}{C} \quad P = \frac{D \times A \times G}{2 \times E \times C}$$

$$G = \frac{P \times E \times C}{2 \times D \times A}$$

In the design of the cams the method shown in Fig. 3 was followed. To locate the cam face:

C = length of lever from the center of suspension to center of cam connection.

G = distance from point of contact of cams to a horizontal line drawn through the centers of cam connections.

J J = piston travel (taken at 8 inches) subdivided into inches.

K K = arc drawn with O as a center and a radius equal to C. This arc must be subdivided into equal spaces corresponding in number to the number of subdivisions on the line J J.

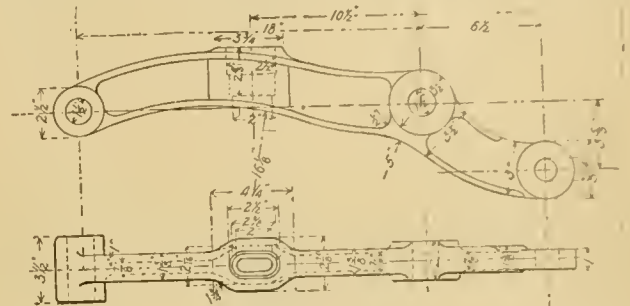

Fig. 4.

L = length of travel of lever at the point of cam connection, allowing 2 1/2 inches for wear of shoe and tire.

M = radius of the arc a a.

With a radius equal to the distance from the point 1, on the arc K K, to the point 8, on the line J J, and with N as a center, strike the arc b b, intersecting the horizontal line 7 7. With radii equal to the distance from each successive point on the arc K K to the point 8, on the line J J (the point of contact of cams), and with N as a center, draw the arcs c c, d d, etc., intersecting each successive subdivision of the line J J. The points of intersection of the arcs b b, c c, etc., with the lines 7 7, 6 6, etc., form the loci of the periphery of the cam face.

On the arc x y locate the link pin 1 1/2 inches from face of cam. The form of the levers is shown in Fig. 4. There are seven

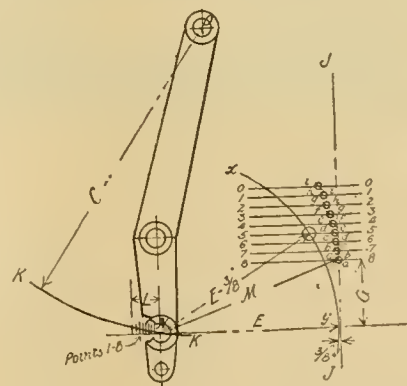

Fig. 3.

different lever patterns and five different cam patterns together with the necessary adjustable links and bolts. One of the links is shown in Fig. 5 and five different sizes suffice for all engines.

The system is quite elaborate and yet very easy of application as all of the parts and all distances needed in putting up the brakes are worked out with care and are tabulated for each class of engine. By following the tables the brake power may be kept very nearly constant, as the calculations are based upon the relation between the angles of the connections with the tangent at the point of contact of the cams. All of the engines as they are brought into the shops for repairs are being fitted with these brakes. We are indebted to Mr. Robert Quayle, Superintendent of Motive Power of the road, for the drawings and details of this work.

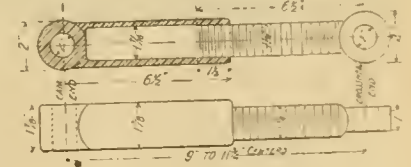

Fig. 5.

Communications.

Construction of Steel Cars.

EDITOR AMERICAN ENGINEER, CAR BUILDER AND RAILROAD JOURNAL:

I beg leave to thank you for your article on "The Passing of the Wooden Freight Car" in the December issue of your paper as I am eagerly watching for every item containing suggestions in regard to the design of cars in metal. This is the most important topic now before railroad men, at least I so regard it, and I hope you will do all that you can to present information and suggestions with regard to the best methods of construction. Almost nothing has been published about the best forms for the frames and the ways in which the steel car should be treated. I think steel cars are rapidly coming upon the scene and we are likely to make serious mistakes by attacking this problem by using old methods now in use in wooden cars, and I think we ought to branch out anew allowing present ideas as applied to wooden cars to pass along with the necessity for them.

To illustrate this, there seems to be a strong inclination to mix wood and steel in the car frames, which, I think, is all wrong. The upper frames will be of wood, but this part of the car is unimportant relatively to the underframe. My point is that we should start all over again in car construction, using only those ideas that belong to the wooden car that are clearly advantageous, and by attacking the problem from the side of the best construction as regards steel shapes we will find out that wood and steel will not mix and that what I will call "wooden ideas" ought not be used in steel underframing. I hope that I have made my meaning plain and if you will agitate this question of the best construction of steel cars, giving prominence to the underframe, you will do me and other interested people a great favor. The future car construction of large capacity cars will, I believe, follow lines of bridge work rather than those of our present practice.

BUILDER.

[We refer our correspondent to the article on steel cars, page 19, this issue.—Ed.]

De Laval's High-Pressure Steam Boiler.

An interesting steam boiler is working in connection with the De Laval steam turbines at the Stockholm Exposition. According to *Engineering*, the exhibit contained four turbo-generators of 66 units each and two boilers of 33 units each, connected with a high-pressure boiler. This plant was run during the greater portion of the day, yielding light and power to the whole of the Exhibition. The steam pressure was kept at 1,700 pounds per square inch.

The general arrangement of the boilers is quite novel, as they are worked automatically. The coals are stoked continuously from a box above the boiler; this box is filled once every two or three hours, according to the load of the turbine. The stoking boxes in the pavilion in the Exhibition were placed in the gallery. The grate is shaped like a ring, and has a revolving motion. The air necessary for the combustion is forced into the boiler by means of a fan coupled direct to the gearing shaft of the turbine. The steam pressure acts on the valves of the blast regulating the combustion, according to the quantity of steam consumed. The steam generator consists of several concentric spirals formed of solid drawn tube, tested under hydraulic pressure of more than double that of the working steam pressure. The feed water is forced continuously into one end of the boiler, and passes through the spirals one after the other with considerable velocity. The steam generated is submitted to superheating before passing to the turbine. There is no steam chamber or large recipient whatever in connection with the boiler; this would be impossible owing to the high pressure. The higher the steam pressure the smaller is the specific volume of the steam, and, consequently, the diameter of the tube can be kept small without involving any great loss in pressure from the velocity of the steam in the tubes. It is claimed that the danger of explosion is practically done away with in this system of boiler. In case a tube should actually burst, the steam in the broken part would immediately rush out, and as much steam would continue to do so as could pass through an opening equal to two sections of the tube—one at each end of the fracture—until the boiler had emptied itself of its contents. This quantity of steam is not greater than what can pass through the flues of the boiler into the smoke stack without causing any damage whatever.

The exceedingly powerful circulation of the water in the boiler naturally makes the heating surface very effective; this circumstance, coupled with the fact that the spaces for steam and water are very small, has made it possible to bring the dimensions of this new boiler within a small compass. A combination, for instance, of a 100 horse-power turbo-generator, with boiler and condenser, occupies only a floor space of 18.9 feet by 11 feet.

The exhaust steam from the turbine is condensed in a surface condenser; from this it is pumped into the hot-water receiver and then again fed into the boiler by the feed pump as in marine engines. By means of a special regulating apparatus the feed pump always feeds into the boiler as much water as the turbine consumes steam; by this arrangement the quantity of water and steam in the boiler, and at the same time the degree of superheat, are kept constant. At variable loads the fire and pressure of steam are regulated by the blast already referred to. The stoking is regulated automatically according to the rapidity of the combustion through the special construction of the revolving grate. The use of air blast has tended to considerably reduce the dimensions of the smokestack.

The De Laval boiler is self-contained requiring no brickwork except the foundation. The air supply passes through an outer shell, whereby it absorbs the radiant heat.

At the Stockholm Exhibition, the boilers, as already mentioned, worked at a pressure of 1,700 pounds, the temperature of the steam being about 600 degrees Fahr. The working parts of the De Laval turbine, it should be remembered, only come into contact with cool, expanded steam, by which arrangement very high degrees of superheat have been made practicable, which is synonymous with great economy of steam.

Yellow Pine Car Lumber.

Yellow pine lumber is used to an increased extent in railroad work, and, says *The Timberman*, all through the season car builders have been making heavy demands, but there is no diminution as yet; and, in fact, the requirement promises to continue through the winter in unabated volume. The demands is not only from independent car shops, but from those which are owned by railroad companies; and is not only for car material but for construction purposes. Car shops are, almost without exception, filled up with orders, and are scouring the yellow pine country for sills, plates, siding, roofing, linings, etc. The Peninsular Car Company, of Detroit, Mich., is turning out its full capacity of 100 cars a day. The price of siding has advanced \$4 or \$5 within the last six months. Prices on sills and plates are higher than they were. The demand for yellow pine is increased by the adoption of this wood by some railroads which have not hitherto used it extensively. It is stated that the New York Central has requisitions out for 85,000 heart, yellow pine ties. The Pennsylvania Company is also going back to yellow pine, after having abandoned it for some time, and has recently placed orders in Georgia for 1,000,000 feet of car stock. Texas is a large buyer of railway material, chiefly ties, and altogether there is an amount of this kind of business which makes it a feature of the season.

Warning to Inventors.

As the new amendments to the patent law go into effect on Jan. 1, 1898, it is well that inventors, both here and abroad, should bear in mind several of the very important changes which may seriously affect their rights.

1. Under the new law a patent cannot be obtained for any invention which has been patented or described in any printed publication in this or any other country more than two years prior to the application.

2. No patent shall be refused nor shall any patent be declared invalid by reason of its first having been patented in a foreign country, unless the said application was filed more than seven months prior to the application in this country.

3. The application must be completed and prepared for examination within one year after the filing of said application. In default thereof it shall be regarded as abandoned.

4. An interference will not be declared between an original application and a patent issued more than two years prior to the date of filing the said application.

In view of these changes in our patent practice, it is desirable that those who are interested and who will be affected by the laws as above mentioned should file their United States applications before Jan. 1.

It should at the same time be borne in mind that the term of the United States patent will not be shortened by the prior filing or issuing of a foreign patent for the same invention. It is possible, therefore, for the American inventor now to proceed with foreign applications without waiting for his United States patent to be issued.—*Scientific American*.

New Laboratory Locomotive—Purdue University.

Much interesting and valuable experimental work has been carried out on the original Purdue laboratory locomotive, and in order to render it possible to keep the investigations "up to date," it was decided to replace the engine with a new one, which should be more nearly comparable with the most recent locomotive practice and should also render it possible to investigate compounding. For these reasons the new one, which we show in the accompanying illustrations, was recently built by the Schenectady Locomotive Works. The general features of the design were outlined by Prof. Wm. F. M. Goss, of Purdue University, and the details were arranged by the builders under the direction of Professor Goss. The total weight of the earlier engine, now designated as Schenectady No. 1, was 85,000 pounds, the cylinders were 16 by 24 inches, and the whole design was becoming out of date, while the greatest value of the data taken is for purposes of comparison with the results obtained in contemporary practice. One of the best features of the new engine is the "assorted sizes" of the cylinders, whereby questions which have never before been investigated may now be studied. The boiler

to fit the supporting rollers, but aside from this the engine might be mistaken for a new, light road engine. The cylinders are attached to the saddle after the old-fashioned method of casting them separate and bolting them in place; this makes it possible to change from a simple to a compound with very little trouble, and with two 20-inch and one 30-inch cylinder, together with a series of cylinder bushings, any combination of cylinders from 16 by 24 inches simple to 16 by 30 inches compound may be had with only three cylinder castings. With these variable proportions together with simple cylinders as large as 20 inches in diameter, the study of modern locomotive cylinder proportions should yield valuable results.

The boiler is of the extended wagon top type, the design and the form of riveted joints used being shown in the engravings. The staying is radial, with three rows of slings at the front. Our drawing shows the detail of the crown stays and the dome braces. The six central rows of crown stays have button heads. The pops are on a separate dome. The firebox is 72 inches long by 34 inches wide; it is between the frames and is of the same depth at both ends, 79 inches. The thickness of the crown sheet is $\frac{7}{16}$ inch, the tube sheet is $\frac{9}{16}$ and the back and side sheets are



Experimental Locomotive for Purdue University, Lafayette, Ind.
Built by the SCHENECTADY LOCOMOTIVE WORKS, Schenectady, N. Y.

is an interesting detail because of the provision for carrying the high pressure of 250 pounds, and this should be the means of giving some very valuable information. We cannot forbear the suggestion that the appearance of the engine is timely in view of the fact that high steam pressures are likely to play an important part in the future development of the locomotive, and it is a cause for congratulation that the new engine is now available for the committee which is to report to the Master Mechanics' Association next June.

The total weight of the engine in working order (there is no tender) is 104,500 pounds, the weight on drivers being 64,000 pounds. The total wheelbase is 23 feet 6 inches. The grate area is 17.74 square feet and the total heating surface is 1,322 square feet, of which 1,195 square feet are in the tubes and 126 square feet in the firebox. There are 260 two-inch tubes.

There are few features of the engine that would be different if it was intended to be used on the road except that the cylinders may be changed and the boiler pressure may be raised to a point far above present practice. The driving wheel tires are turned

$\frac{3}{8}$ inch thick. The tubes are 11 feet 6 inches long, and except that the boiler is very strongly built there is nothing specially noteworthy about it.

Among the details of the design it is interesting to note that the axles are of nickel steel and that they are made hollow. They were furnished by the Bethlehem Iron Company, and in the testing machine the material showed the following characteristics: Ultimate tensile strength, 91,000 pounds per square inch; elastic limit, 57,000 pounds per square inch; elongation, 25.05 per cent.; contraction, 56.45 per cent. The test specimens were 2 inches long between the points of measurement. These manufacturers also furnished the crank pins, the crossheads pins and the piston rods. These forgings are all of fluid-compressed acid open-hearth nickel steel and all but the piston rods are hollow and oil tempered. The great mortality of these parts in locomotives has led engineers to seek for some metal of high elastic limit and elongation which would successfully resist the severe alternating stresses to which they are subjected. When steel was first substituted for wrought iron in locomotive crank pins, a soft low carbon steel

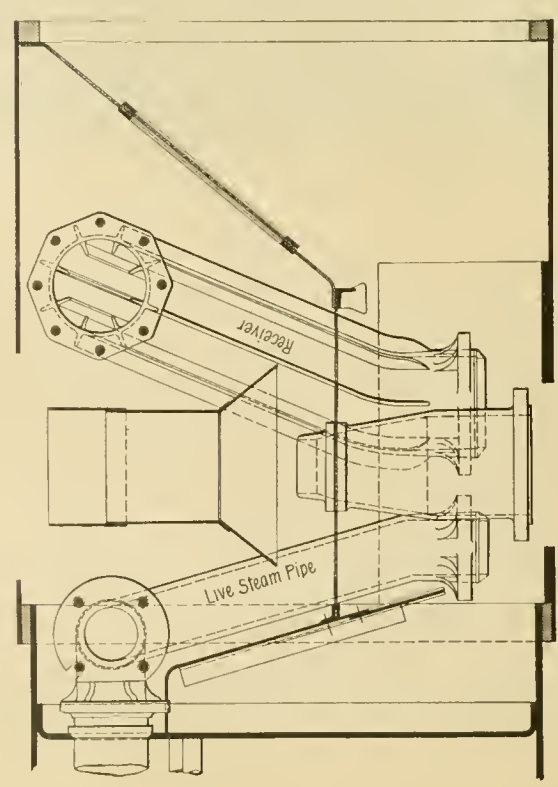
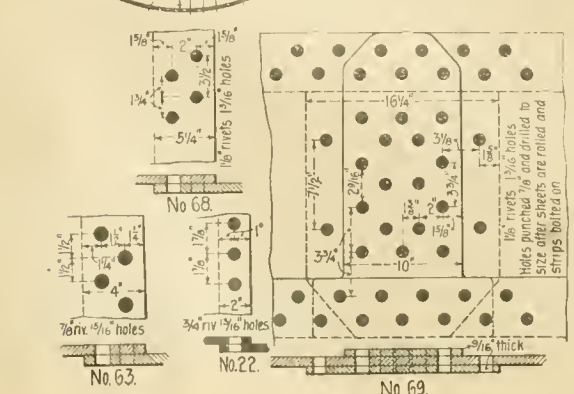
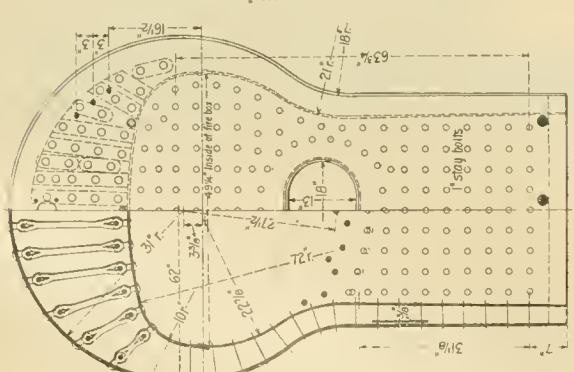
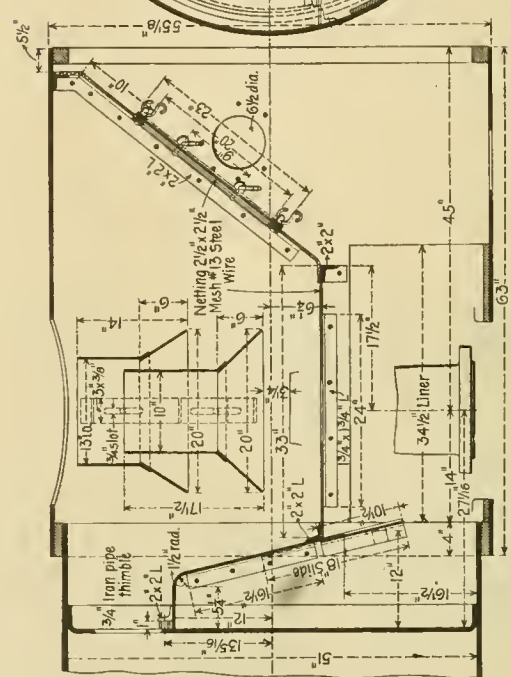
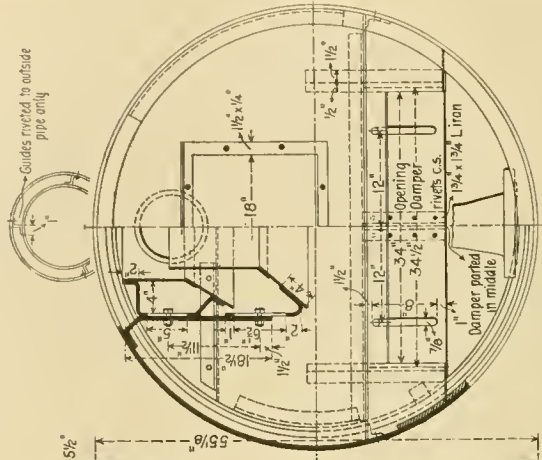
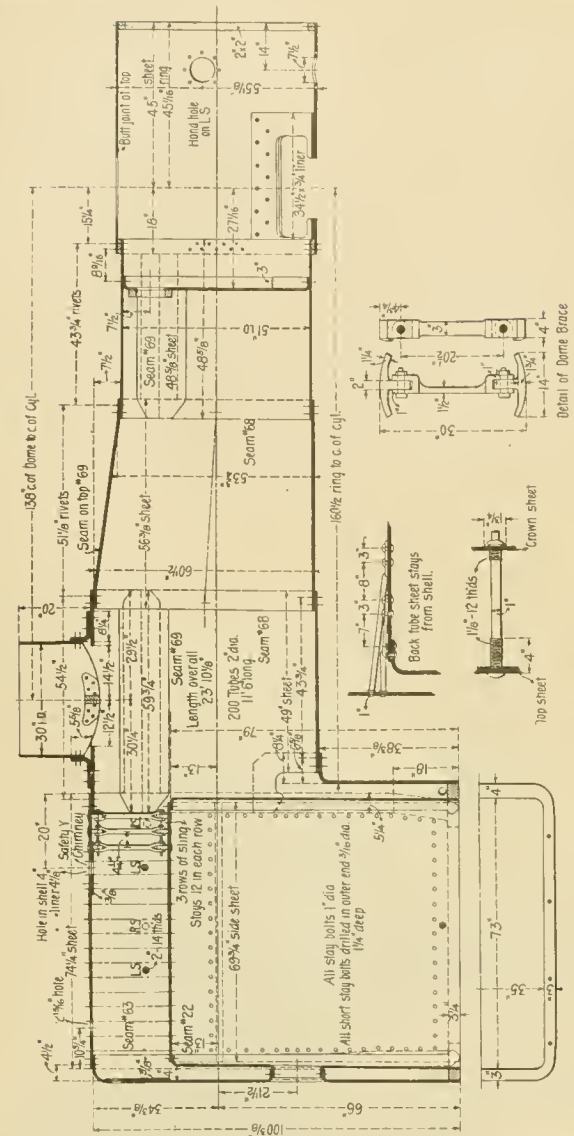

EXPERIMENTAL LOCOMOTIVE FOR PURDUE UNIVERSITY—BOILER AND SMOKEBOX DETAILS.

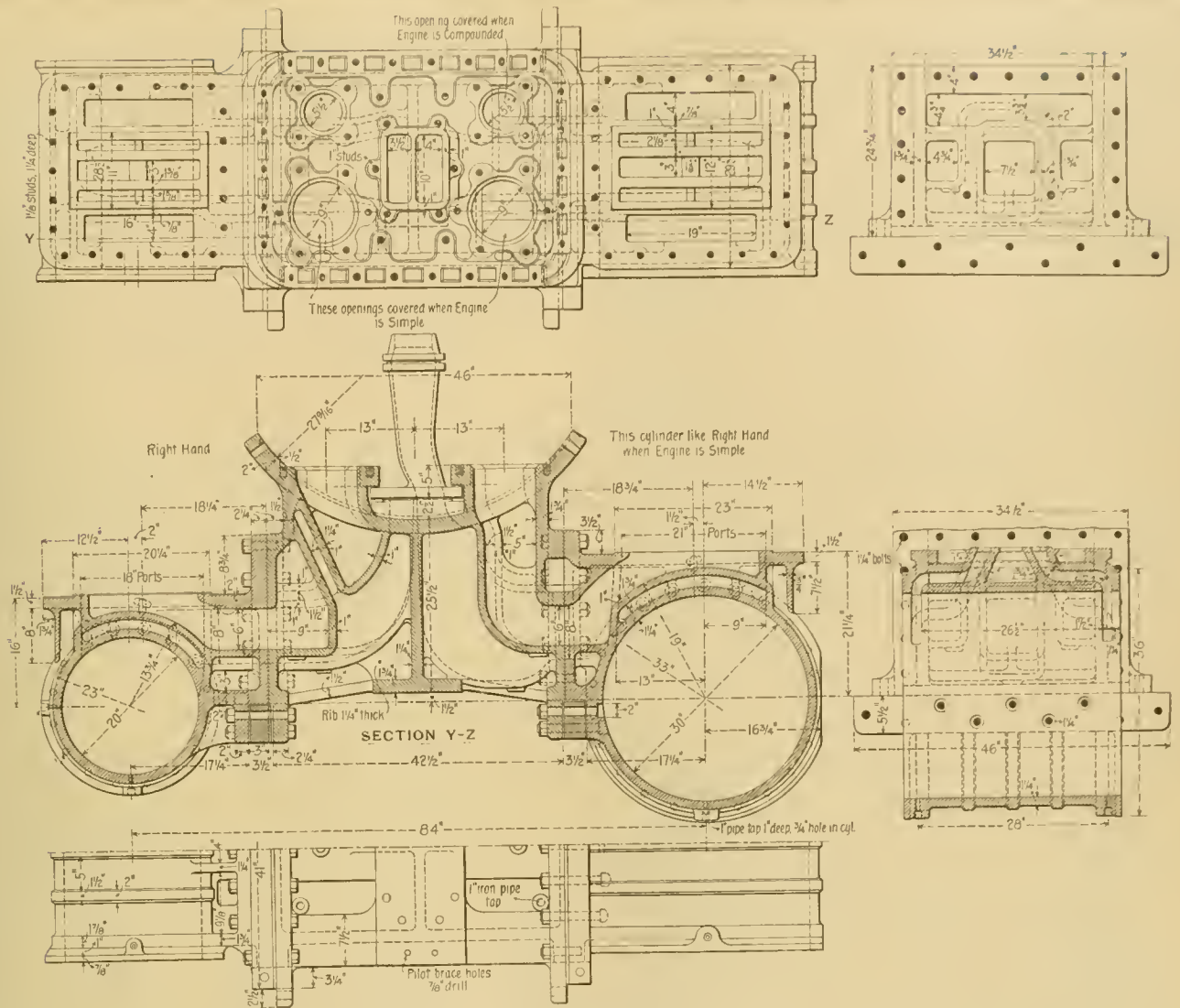

Experimental Locomotive for Purdue University—Plan and Sections of Cylinders.

was generally employed and failures due to "fatigue of metal" were almost as frequent as before. The broken pins showed what had been called "a fracture in detail," a gradual parting of the steel extending inward all around the piece, undoubtedly produced by the working strains repeatedly approaching the low elastic limit of the soft steel. On substituting a higher carbon steel with an elastic limit of 45,000 to 50,000 pounds per square inch, failures were greatly diminished without changing the diameter or shape of the pins. Steel of still higher elastic limit and proportionately greater elongation gives correspondingly better results and some of the representative railroads of the country are considering the adoption of, and others have already adopted, nickel steel wherever it can be used on their locomotives, and where the form and size of the forgings will allow of such treatment they are made hollow in order that they may be oil-tempered to still further increase the physical properties of the metal. The driving axle journals are 7 1/2 inches in diameter and 8 1/2 inches long. The driving boxes are of "steeled cast iron" and the bearings are of Ajax metal. The engine frames are composite, the tongues being of wrought iron and the main portions of cast steel.

An examination of the cylinder drawings will show that the low-pressure cylinder is secured to the frame by horizontal bolts passing through the cylinder walls, a practice that is becoming quite common in connection with large cylinders. When the engine is changed from simple to compound the receiver openings are closed, and the Master Mechanics' exhaust nozzle is used; this change is very easily made with the arrangements provided. We show the arrangement of the steam and receiver

Exhaust Nozzle Used with Simple Arrangement.

pipes and the smokebox attachments, which will readily be understood. The general dimensions of the engine are summarized as follows:

General Dimensions.

Gauge	1 foot 8 1/2 inches
Fuel	Bituminous coal
Weight in working order	101,500 pounds
" on drivers	61,000 pounds
Wheel base, driving	8 feet 6 inches
" " rigid	8 feet 6 inches
" " total	23 feet 6 inches

Cylinders.

Diameter of cylinders	16 and 30 inches
Stroke of piston	24 inches
Horizontal thickness of piston	5 1/4 inches
Diameter of piston rod (material, Bethlehem Iron Works nickel steel)	2 3/4 inches
Kind of piston packing	Cast iron rings
" rod packing	Jerome metallic
Size of steam ports	18 inches by 1 1/2 inches
" exhaust	18 inches by 3 inches
" bridges	1 1/2 inches

Valves.

Kind of slide valves	Allan-Richardson
Greatest travel of slide valves	6 inches
Outside lap	1 1/4 inches
Inside lap	Lines and line
Lead of valves in full gear	Lines and line
Kind of valve stem packing	Jerome metallic

Wheels and Journals.

Diameter of driving wheels outside of tire	69 inches
Material " " centers	American cast steel
Tire held by	Shrinkage and retaining rings
Driving box material	Steel or cast iron
Diameter and length of driving journals (axles, Bethlehem I. Works nickel steel, hollow)	7 1/2 inches diameter by 8 1/2 inches
Diameter and length of main crank-pin journals (crankpins, Bethlehem I. Works nickel steel, hollow)	5 inches diameter, by 5 inches
Diameter and length of side rod crankpin journals (crankpins, Bethlehem I. Works nickel steel, hollow)	F, 5 1/2 inches diameter by 3 3/4 inches; B, 4 1/2 inches diameter by 3 3/4 inches
Engine truck, kind	Four-wheel, rigid center journals
Diameter of engine truck wheels	28 inches
Kind	Steel-tired, cast-iron spoke center

Boiler.

Style	Extended wagon top
Outside diameter of first ring	5 1/2 inches
Working pressure	250 pounds
Material of barrel and outside of firebox	Carnegie steel
Thickness of plates in barrel and outside of firebox	3/8 inch, 3/4 inch, 1/2 inch and 1/4 inch
Horizontal seams	Butt joint, sextuple-riveted, with well strip inside and outside
Circumferential seams	Double riveted
Firebox, length	72 1/2 inches
" width	34 1/4 inches
Firebox, depth	79 inches
" material	Carbon steel
" plates, thickness	Sides, 3/8 inch; back, 3/8 inch; crown, 1/2 inch; tube sheet, 1/4 inch
" water space	1 inch front; 3 to 3 1/2 inch sides, 3 to 4 inch back
" crown staying	Radial stays, 1 1/2 inches diameter
" staybolts	1 inch diameter
Tubes, material	Charcoal iron, No. 12 W. G.
" number of	200
" diameter	2 inches
" length over tube sheets	11 feet 6 inches
Fire brick, supported on	Studs
Heating surface, tubes	1,195.54 square feet
" " firebox	126.46 square feet
" " total	1,322 square feet
Grate surface	17.71 square feet
" style	Rocking, ordinary bars
Ash pan, style	Plain, with dampers, F. & B.
Exhaust pipes	Single, high nozzles
" nozzles	1 inches, 4 1/4 inches, 1 1/2 inches diameter
Smokestack, inside diameter	Taper cast iron, 14 inches near bottom
" top above rail	13 feet 8 1/2 inches
Boiler supplied by	Two Sellers Class "N" improved; injectors No. 6 1/2 and No. 8 1/2 L. S.

The boiler is jacketed with magnesia covering furnished by Keasbey & Mattison; the pop valves were furnished by the Ashton Valve Company; the lubricators are provided with the improved Tippet attachment and were furnished by the Detroit Lubricator Company; William Sellers & Company supplied the boiler cheeks and two Class N injectors, Nos. 6 1/2 and 8 1/2. The engine has the McIntosh blow-off cock.

The Mileage of Chilled Cast-Iron Wheels in Freight and Passenger Service.

The chilled cast-iron car wheel is one of the greatest, if not the greatest, triumph of the iron founder's art. The production of wheels, combining in one casting the toughness and strength necessary to hold up the heavy loads, while enduring severe shocks with the wear-resisting properties necessary to withstand the abrasion of rails and brakeshoes and at the same time rendering wheels with these requisites available at low cost, has had much to do with the enormous development of American railroads.

In our September, 1896, issue, we printed a table giving the mileage of cast-iron wheels on the Chicago, Milwaukee & St.

Paul Railway, which was published through the courtesy of Mr. J. N. Barr, Superintendent of Motive Power of that road. Mr. Barr, in response to a request for information which would enable us to bring the table then presented up to date, to include the years 1896 and 1897, has kindly furnished the information from which the following tables have been prepared, and it will be noted that these include wheels in passenger as well as in freight service.

CHICAGO, MILWAUKEE & ST. PAUL RAILWAY COMPANY, OFFICE SUPERINTENDENT MOTIVE POWER. }
STATEMENT SHOWING SERVICE OF FREIGHT CAR WHEELS

Year.	Number of freight wheels made or bought.	Freight car mileage.	Number of freight cars.	Number of freight wheels in service.	Average mileage.	Average life of wheels.		
						Year.	Month.	Days.
1885	22,395	245,459,307	19,412	155,216	76,568	6	11	15
1886	19,459	236,130,419	21,355	171,080	97,080	8	9	15
1887	21,721	250,774,965	21,678	173,424	81,153	7	0	1
1888	24,162	261,400,622	22,514	180,352	86,544	7	5	17
1889	26,015	250,930,286	22,776	182,208	77,483	7	0	1
1890	15,823	263,983,845	23,861	194,912	133,468	12	0	21
1891	12,810	305,432,811	25,674	205,392	190,776	16	0	12
1892	17,340	334,913,674	26,308	210,372	154,528	12	1	14
1893	17,332	312,503,242	27,963	223,612	141,210	12	10	1
1894	11,617	276,300,355	27,800	224,406	189,781	19	1	1
1895	11,219	289,316,350	27,687	221,408	162,776	15	6	26
1896*	19,569	315,810,431	27,645	221,072	129,104	11	3	22
1897*	14,634	292,285,995	27,517	220,648	159,784	15	0	13

* These records are on fiscal year basis.

STATEMENT SHOWING C. M. & ST. P. R. V. CAST WHEELS IN PASSENGER SERVICE.

All Wheels Scrapped Except for Sliding.

Year.	Passenger.		Bag, mail and express.		Parlor and sleeper.		Total.	
	No. of wheels.	Average mileage.	No. of wheels.	Average mileage.	No. of wheels.	Average mileage.	No. of wheels.	Average mileage.
1885	80	46,468	811	45,641	65	42,708	1,676	45,731
1886	513	67,040	500	73,380	45	77,192	1,058	70,468
1887	391	80,213	470	88,379	28	95,366	889	85,053
1888	378	92,249	449	107,376	9	99,879	836	100,455
1889	455	100,861	477	112,031	9	141,706	911	106,916
1890	529	97,808	535	106,161	17	96,291	1,081	101,919
1891	892	96,919	885	109,673	51	102,695	1,828	103,252
1892	1,118	101,386	1,015	111,833	61	95,502	2,194	105,852
1893	1,098	99,139	1,092	110,838	29	122,998	2,219	105,218
1894	1,303	107,688	1,046	112,979	38	107,265	2,387	109,999
1895	1,411	106,949	1,002	114,542	48	93,714	2,461	110,127
1896	1,293	107,793	1,211	115,633	126	103,375	2,630	111,215
1897	1,518	101,748	1,439	110,136	182	99,991	3,139	105,250

All Wheels Scrapped on Account of Sliding.

Year.	No. of wheels.	Average mileage.	No. of wheels.	Average mileage.	No. of wheels.	Average mileage.	No. of wheels.	Average mileage.
1885	610	23,936	543	18,218	96	12,514	1,279	20,654
1886	363	31,525	220	33,108	21	23,998	607	31,501
1887	337	44,467	324	48,352	12	68,080	673	46,759
1888	535	48,866	434	49,940	17	32,908	986	49,661
1889	391	51,596	346	60,705	4	49,874	911	54,936
1890	354	47,277	250	51,110	2	5,940	606	48,732
1891	466	49,142	271	48,573	41	38,770	778	48,360
1892	586	48,197	397	45,432	39	39,668	1,022	46,821
1893	715	38,307	419	42,302	25	41,536	1,159	39,886
1894	653	43,353	368	42,842	44	29,679	1,065	42,610
1895	613	37,818	218	52,967	78	29,882	909	40,771
1896	382	38,280	219	43,188	125	32,392	726	38,747
1897	730	34,660	274	33,876	247	22,077	1,251	32,604

All Wheels Scrapped.

Year.	No. of wheels.	Average mileage.	No. of wheels.	Average mileage.	No. of wheels.	Average mileage.	No. of wheels.	Average mileage.
1885	1,110	36,232	1,354	34,612	161	23,319	2,955	34,835
1886	876	52,322	720	61,047	69	58,618	1,665	56,359
1887	718	63,681	794	72,466	40	87,881	1,562	68,554
1888	913	66,827	883	79,146	26	56,691	1,822	72,615
1889	1,146	73,027	823	90,159	13	113,450	1,982	80,798
1890	843	77,437	785	88,629	19	86,710	1,687	82,750
1891	1,358	80,521	1,156	95,515	95	73,929	2,609	86,887
1892	1,704	82,568	1,412	92,133	100	73,727	3,216	86,479
1893	1,813	75,151	1,511	92,460	54	87,411	3,378	83,086
1894	1,956	86,207	1,412	91,799	82	65,634	3,450	89,235
1895	1,757	89,036	1,220	102,865	126	51,199	3,103	93,219
1896	1,675	91,910	1,430	101,538	251	68,674	3,356	95,568
1897	2,248	79,181	1,713	97,921	19	55,134	4,390	84,143

* Fiscal year basis.

The average mileage is obtained by dividing the total car-mileage during the year by the number of wheels taken out. If 10,000 wheels are in service and 1,000 are removed each year, the

average length of service would be 10 years and the average mileage would be 10 times the yearly mileage of the cars. As previously explained, this does not give accurate figures for any particular year, but it does give a correct method of comparison when a number of years are covered, and the statement shows the average mileage of all wheels taken out for all causes.

The average mileage for the past eight years is much larger than before that period, and there is a variation between 133,000 to 190,000 miles in the eight years. It has already been pointed out that between the years 1889 and 1890 there was a sudden jump in the figures, which is probably due to the introduction of the contracting chill which has been used for a large proportion of wheels cast since that time.

The American Society of Mechanical Engineers' Winter Meeting.

The first session of the meeting was called to order by the Secretary at 9 p. m. November 30, with the largest attendance in the history of the Society. The President, Mr. Worcester R. Warner, took for the subject of his address, "The Telescope Historically and Practically Considered," and illustrated it by lantern slides.

The address was an interesting and instructive presentation of the evolution of the present astronomical telescope from the earliest record, the influence of the engineer in its development being clearly brought out. It was the improvements in the manipulating mechanism whereby the observer might do accurate work in comfort, and those which permitted of the attachment of the camera to the telescope that enabled the astronomer of to-day to complete in 40 minutes observations that formerly required four years.

The Yerkes telescope was described in considerable detail, as it was the largest in existence, the objective being 40 inches in diameter, weighing 1,000 pounds. The tube was 62 feet long and weighed six tons, while the complete telescope weighed 70 tons. The clock for moving the telescope in following the movements of stars was obliged to move and keep in motion, a weight of 22 tons and in order to obtain satisfactory results the mechanism was required to be accurately made and provided with bearings having low fractional resistance. This movement was accomplished by a large clock acted upon by a weight of 850 pounds, falling at the rate of one and one-half feet per minute. This telescope and a large number of other typical ones, as well as the chief astronomical observatories, were shown on the screen. The paper was enjoyed and appreciated by the audience.

Second Session.—Annual Report of the Council. The chief features of this report were the usual financial statements, an amendment providing for the reception of candidates for membership who, by their location in foreign countries, might not have a sufficiently large acquaintance among the membership to enable them to secure the recommendation of five members. The report was adopted. It was announced that the standard oval decimal gauge had been patented by the Society in order to prevent improper use of it. It was stated that Messrs. Pratt & Whitney had been authorized to make the gauges under the patent and that other firms might secure the right to use it by making application.

The next business was the report by Mr. Gus Henning upon the meeting which he attended at Stockholm, where he represented the Society in the conference held to discuss the subject of uniform methods of testing materials. The report was interesting and it was evident that much progress had been made in the direction of international effort toward standardization. The reporter spoke of the great advantages to be gained by the use of standard specifications and showed that the cost of steel products would be materially reduced by their introduction and that the difficulties of inspection would be very much simplified. It was ordered that the council should appoint a committee to act with the American section of the international organization and to represent the Society in the movement.

The report of the tellers of the election was presented, showing that the following officers were elected:

President, Mr. C. W. Hunt; Treasurer, Mr. W. H. Wiley; Vice-Presidents, E. S. Cramp, S. T. Wellman, W. F. Durfee, John C. K. Afer, David R. Fraser, Walter S. Russell; Managers, N. C. Stiles, E. D. Meier, G. W. Dickie, H. S. Haines, Gus C. Henning, A. W. Robinson, Jas. B. Stanwood, H. H. Supplee, George Richmond.

The report of the committee appointed to revise the standard code of rules for the conduct of boiler trials was then received. This report was explained by Mr. Keut to be a draft of a proposed

report rather than the report itself and the committee asked for the assistance of the members in the way of suggestions. A number of suggestions were made by members and the discussion was laid over until a later session.

A letter was then read from Mr. E. M. Herr suggesting the advisability of action on the part of the Society in regard to the work undertaken by the joint committee of the Master Mechanics' and the Master Car Builders' associations in regard to the standardization of pipe fittings. It will be remembered that Messrs. W. H. Marshall and C. H. Quereau are also members of that committee. The Society voted to submit the matter to a committee which should assist in this work. The importance of the subject was fully recognized by the Society.

The paper by Mr. F. W. Deau, entitled "Reduction in Cost of Steam Power from 1870 to 1897," was then read. We print extracts from it in this issue. It was full of valuable facts and awakened a somewhat animated discussion, which consisted largely in a defense of the water tube type of boiler. This defense was called forth by a statement by the author in the paper to the effect that the standard boiler of this country was the cylindrical type. We do not think the author suffered in the least in the discussion. The advantage of the reheater in steam-engine practice was called into question, but the author believed that when sufficiently high temperatures were used the advantage was marked.

The next subject was the paper by Mr. W. W. Christie, "Boiler Tests: Classification of Data and Plotted Results." It was a comparison of boilers by the results of numerous tests and concluded with a series of diagrams.

Third Session.—Prof. R. C. Carpenter's paper, "Test of Centrifugal Pump and Calibration of Weir at the Bridgeport Pumping Station, Chicago," was read. The pumps were described and the methods of the tests and the results were explained. Two pumps, one of the centrifugal and the other of undulating type, were tested; the first gave an efficiency of 54 per cent. when pumping 10,000 cubic feet of water per minute and the second gave an efficiency of only 41 per cent. under similar conditions. A weir was used for measuring the water. The author's experience showed him the advantages of building weirs so that they would have the minimum of end contraction. It was a case of a very large flow of water over a weir nearly 30 feet long, with means of checking the results, and was considered as establishing the Weisbach formula in place of that of Francis for these conditions. In view of the low efficiencies the paper clearly showed the importance of expert engineering advice in the selection and specification of pumping engines.

The next paper was by Mr. Howard Stillman, Engineer of Tests of the Southern Pacific Ry., entitled "A Water Purifying Plant." A very complete plant for the purification of feed-water for the use of locomotives was described, and the subject is of such interest that we reprint the paper in abstract in this issue. The discussion drifted somewhat from the paper, and brought out the fact that many of the members had used simple methods for the protection of their boilers, and of these methods the use of soda ash and electrical currents were mentioned. There were differences of opinion in regard to the efficacy of copper and zinc plates for the purpose of setting up electric currents in the boiler, but this plan had excellent support. It was thought to act in such a way as to prevent the crystallization of the precipitates in the boiler, the effect of which was to throw down mud instead of scale. Others called this process a humbug, but they did not present a strouge case.

Dr. Thurston's paper, "Multiple Cylinder Engines: Effects of Variation of Proportions and Variable Loads," was then read by the author. This paper was an interesting record of experiments which tended to show that for certain conditions there was more to be gained in the use of compound engines of unusual proportions, a ratio of 7 to 1, than in the use of triple expansion engines. This subject was important, and we hope to find room for an abstract of the paper in a future issue. It was shown that it was possible to abandon the intermediate cylinder of the triple expansion engine in certain cases, not only without loss but with actual gain. The substance of the paper was expressed as follows: The unusual proportions of 7 to 1 in a compound engine approximated closely to the results from the triple engine at the most favorable expansion ratio for the triple.

Mr. Wm. S. Keep's paper on "Cast Iron Under Impact" was then read. The object of the paper was to record the results of an elaborate series of tests upon the effects of impact upon cast iron, including the effects of "tumbling" castings in a "tumbling barrel." The

result was to show that strength was increased by this action, but the effects considered quantitatively did not appear to be very uniform. The discussion was brief. The tests were not complete, but they show that:

Striking a test bar on the side or end decreases its length. Test bars tumbled in contact with other castings in a tumbling barrel increase in length. Tumbled test bars show large increase of strength. Blows delivered on the side or end of a test bar do not increase the strength. Test bars $\frac{1}{2}$ inch square increase in strength until they have been tumbled two or three hours, but not materially by long tumbling. Of tumbled bars the weakest bars are most strengthened and the strongest bars are strengthened very little. The strength gained by tumbling is due to making the surface of the test bar smooth and to condensing the surface by peening. The removal of the surface weakens a test bar while smoothing the surface without removing it strengthens it. Smoothing the surface by pounding with a hammer increases the strength by condensing the grain. Test bars of gray iron containing least silicon gain most by the process of tumbling.

"Notes on Rating Electric Plants on the Heat Unit Standard," by Mr. W. S. Aldrich, was then read. This paper takes up in detail the subject introduced by the author at the previous meeting. The substance of this presentation was that the application of the same method of specifying the performance of electric power plants that had such a good effect upon the development of the pumping engine might be expected to work a similar improvement in the electric power plant.

Fourth Session.—The first paper was by Mr. J. B. Mayo, "A Strength of Gear Chart." The purpose of the paper was to record data with regard to the strength of gears in a form convenient for use in selecting gears for any special purpose. It was offered as a time saver. Mr. C. L. Griffin submitted written discussion, including another gear chart showing the load, pitch, width and factor of strength. He thought Mr. Mayo's chart covered too much.

The next paper was on "The Law of Hydraulic Obstruction in Closed Streams," by Mr. David Guelbaum. It had to do with the laws governing phenomena attending the obstruction of closed conduits and consisted of exhaustive mathematical treatment and included a formula.

The conclusion of the discussion on the report of the committee on revision of the code of rules for boiler tests was then opened by Mr. Charles E. Emery, who invited suggestions from the members. Professor Jacobus thought it very important to determine the amount of moisture in steam and illustrated a method in which three Barrus calorimeters were used, the samples being taken from nipples from the bottom and from different parts of the steam pipe, the area of the pipe being, in fact, explored for moisture. He thought that mercury instead of oil wells ought to be used for measuring superheating. Mr. Kent showed Professor Ringelmann's smoke scale, which was a new way of determining smoke by comparison with surfaces shaded in accordance with a formula. Water meters for measuring feed water were strongly condemned and actual weighing was endorsed. It was thought by several speakers that 10-hour tests must be inaccurate, 72 hours being thought necessary for the purpose of securing fair conditions.

Mr. C. J. H. Woodbury presented a report on the subject of electric wiring rules, which was adopted and will be printed in full in the proceedings.

Fifth Session.—This was opened by Mr. George W. Bissell's paper, "A Boiler Setting," which described a method of supporting a boiler from three points in such a way as to take care of expansion and contraction, and also to render the supports independent of the setting. No discussion.

Mr. George W. Dickie's paper, "Auxiliary Engine and Transmission of Power on Naval Vessels," was then read. An idea of the paper may be best obtained from the following quotation.

This paper does not aim to show the superiority of any one system over another, the comparisons made being simply to show that there is no mechanical difficulty in operating all auxiliaries by any one of the systems herein mentioned, and to express a hope that our government would either adopt some one system and carry it out complete, developing that system to its utmost efficiency, or else take one or two similar ships and fit them with power transmission systems completely representing different agents—say one electric, one hydraulic and one compressed air. Let each be placed for three years in the hands of officers heartily in favor of the system in use on their own ship, and thereby obtain a practical demonstration of the very best points in each system.

While we have hitherto advocated with all the ability we possess a complete hydraulic system, our experience in the practical working of hydraulics on shipboard has not been of the most pleasant character. Officers are required to care for and get the best out of a hydraulic system, while personally they would rather sit up all night with an electric plant than spend a moment more than the law requires with a water motor.

The future hopes of the young officer are centered in electricity, and he devotes himself to it with a will; and so long as that condi-

tion prevails, the electric method of transmission will have the best chance to succeed, because, with that it has a flexibility and a general adaptability which the other systems do not in themselves possess.

In the discussion it was shown that while compressed air itself is safe, several air compressors had exploded on account of the vaporization of lubricating oil, but this might be avoided by water jacketing of the compressor cylinders.

Mr. H. M. Norris' paper, "An Accurate Cost Keeping System," contained the assertion that this subject precluded all forms of guesswork, which was the fundamental principle of cost keeping. The method devised by the author was described in detail, and included the forms of blanks used in determining the actual cost of each job of machinery work, including office and selling costs. The system involved monthly reports. In practice it had been very satisfactory. The discussion was lengthy, and treated the separation of the manufacturing and selling expenses and the general advantages of cost keeping. Mr. C. W. Hunt suggested that members interested should read the work by J. Slater Lewis, describing an English cost keeping system which was used very successfully in the speaker's works. The system permitted of balancing every month, and gave a satisfactorily accurate method for keeping track of the business. The clerical work was done by cheap labor, and required no thinking on the part of the clerks. A system that would show the cost of sharpening the President's skates was one member's way of describing a perfect system.

The next paper was "Thermodynamics Without the Calculus," by Mr. George Richmond. It presented the state of the art of a new method of treating thermodynamics without higher mathematics. The paper was intensely interesting and very valuable, but for the lack of time it was not discussed.

Mr. Chas. T. Main's paper on "The Valuation of Textile Manufacturing Property" was read. Its scope was well represented in the title.

Owing to the length of the earlier discussions the remaining papers were presented without much discussion. They were taken up as follows: "A Staybolt Threading Device and a Screw-die for the Turret Lathe," by Mr. Jas. Hartness; "Dustless Buildings," by Mr. C. J. H. Woodbury; "The Stevens Valve Gear for Marine Engines," by Mr. Andrew Fletcher; "Machine Moulding," by Mr. E. H. Mumford; "Electricity in Cotton Mills," by Mr. W. B. Smith-Whaley, and "A Convenient Form of Wire Testing Machine," by Mr. A. L. Rice.

The convention closed with a brief address by the President, Mr. Worcester R. Warner, who in a few well-chosen words expressed his gratification in the treatment that he had received and the assistance that had been given him by the officers and members.

It was announced that the next convention will be held at Niagara Falls, the date not yet being decided.

Locomotives for China—The Rogers Locomotive Company.

The Rogers Locomotive Company has completed and is now shipping eight mogul locomotives for the Imperial Government railways of China, these being for use on the Lu Han Railway. The gauge is standard, and with the exception of the six-wheel tender the design strongly resembles American practice. The following table contains a general description of the locomotives:

General.

Gauge.....	4 feet 8½ inches
Fuel.....	Bituminous coal
Weight on drivers.....	105,000 pounds
" truck wheels.....	20,500 pounds
" total.....	125,500 pounds
Wheel base, total, engine.....	22 feet 9 inches
" driving.....	13 feet 9 inches
" total (engine and tender).....	46 feet 11 inches
Height, center of boiler above rails.....	8 feet 8 inches
of stack.....	14 feet 10 inches
Heating surface, firebox.....	126.15 square feet
tubes.....	1,503.35 square feet
" total.....	1,629.50 square feet
Grate area.....	21.2 square feet

Wheels and Journals.

Drivers, number.....	6, of cast steel
diameter.....	60 inches
Truck wheels, kind.....	Cast steel
diameter.....	36 inches
Journals, driving axle, size.....	8 inches by 10 inches
truck.....	5½ inches by 12 inches
Axles, driving, material.....	Steel
truck.....	Steel

Cylinders.

Cylinders, diameter.....	19 inches
Piston stroke.....	21 inches
rod, diameter.....	3½ inches
Kind of piston-rod packing.....	U. S. metallic

Main rod, length center to center.....	8 feet 9 inches
Steam ports, length.....	17 inches
" width.....	1 3/4 inches
Exhaust ports, length.....	17 inches
" width.....	2 3/4 inches
Bridge, width.....	1 3/4 inches
Exhaust pipe.....	Single, high
<i>Valves.</i>	
Valves, kind of.....	Richardson
" greatest travel.....	5 1/2 inches
" outside lap.....	1 1/2 inch
" lead in full gear.....	1 1/4 inch
<i>Boiler.</i>	
Boiler, type of.....	Belpatre
" working steam pressure.....	180 pounds
" material in barrel.....	Steel
" thickness of material in barrel.....	9/16 inch
" diameter of barrel outside at first course.....	60 inches
Seams, kind of horizontal.....	Sextuple riveted
" circumferential.....	Double riveted
Crown sheet stayed with.....	Radial stays
Dome, diameter.....	30 inches
<i>Tubes.</i>	
Tubes, number.....	214
" material.....	Iron
" outside diameter.....	2 inches
" length over sheets.....	13 feet 5 inches
<i>Firebox.</i>	
Firebox, length.....	7 feet
" width.....	3 feet 5 1/2 inches
" depth front.....	69 1/2 inches
" back.....	60 1/2 inches
" material sides, back and crown.....	Copper, steel tube plate
" thickness of sheets.....	1/2 inch
" brick arch.....	Supported on studs
Grate, kind of.....	Rocking flinger
<i>Tender.</i>	
Tank capacity.....	4,000 gallons
Coal.....	7 tons

amounts the same extenders or fillers as the freight car color, and like it excludes barytes. The Tuscan red also contains as an essential constituent a percentage of organic coloring matter, usually what is known as chatemuc, or wood lake, or an alizarin lake. A minimum percentage of sesquioxide of iron being an essential feature of the specifications, a rapid and at the same time accurate method for its determination is desirable. The directions given below seem to secure this result.

OPERATION.

Remove the pigment from the six-ounce Erlenmeyer flask, in which it is left in the methods describing how to separate the pigment from the other constituents of freight and passenger car colors, previously published in these articles,* by means of a spatula, taking care to get out all that can be so detached. The pigment, being received on smooth or glazed paper, is then mixed with the spatula, the lumps which are apt to be present being crushed in the operation. A uniform sample being obtained, weigh into a small porcelain crucible half a gram of the pigment, and ignite to destroy organic matter, avoiding very high temperatures. Put the ignited pigment into a two or three ounce beaker, and dissolve in hydrochloric acid, taking pains to clean the crucible by washing with some of the acid, and rubbing with a rubber tube on the end of a glass rod. Use in all 15 cubic centimeters of chemically pure hydrochloric acid, 1.10 specific gravity. In dissolving use heat: solution usually takes only a few minutes. In case of a refractory pigment, a few drops of the

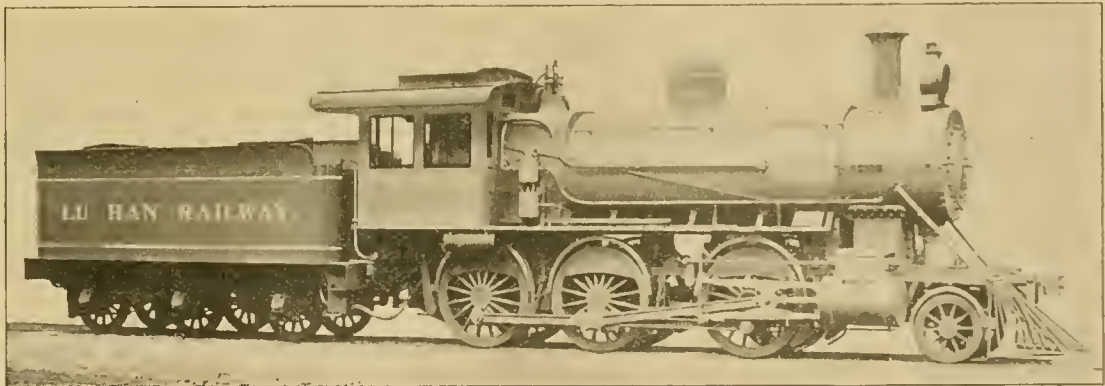

Locomotive for China.—By the Rogers Locomotive Company.

Frame, type of.....	Steel plate 6-wheeled
Wheels, kind.....	Cast steel
" diameter.....	42 inches
Axle, material.....	Steel
Journals, size.....	5 3/4 x 10 inches

CONTRIBUTIONS TO PRACTICAL RAILROAD INFORMATION.

Chemistry Applied to Railroads—Second Series—Chemical Methods.

XXII.—Method of Determining Sesquioxide of Iron in Freight Car and Passenger Car Colors.

BY C. B. DUDLEY, CHEMIST, AND F. N. PEASE, ASSISTANT CHEMIST, OF THE PENNSYLVANIA RAILROAD.

EXPLANATORY.

The pigment of the standard freight car color is a mixture of sesquioxide of iron, with a little carbonate of calcium, and quite a large amount of various inert materials as extenders or fillers. These may include kaolin, gypsum, ground soapstone, silic, feldspar and asbestos or ground asbestos, as well as the natural impurities occurring in the iron ores, frequently used to furnish the required sesquioxide of iron. Barytes, or sulphate of barium, is excluded. The standard passenger car color, or Tuscan red, has likewise a basis of sesquioxide of iron, together with a small percentage of carbonate of calcium, and may contain in small

standard stannous chloride solution added from time to time greatly hastens solution: an excess should be avoided. When solution is complete, if stannous chloride has not been used, the solution will, of course, have the reddish color characteristic of ferric chloride. If stannous chloride has been used, even in very slight excess, the solution will be nearly colorless. The subsequent manipulation in the two cases differs. In the first case, while the liquid is still hot, add from a burette or pipette the standard stannous chloride drop by drop with agitation until the solution has lost the greenish yellow color, which is characteristic of the partially reduced solution. The smallest possible excess of stannous chloride should be present after reduction is complete. One drop after the color is gone will insure complete reduction. In case stannous chloride has been used to secure solution, add permanganate of potash solution, until the greenish yellow color characteristic of a partially reduced iron solution appears, and then add stannous chloride from a burette or pipette, until reduction is complete, as above described. Add now to the reduced solution five cubic centimeters of mercuric chloride solution, taking care to wash down the sides of the beaker containing the reduced solution with the mercuric chloride. Mix thoroughly and then pour the reduced solution into a beaker holding 500 cubic centimeters and containing 400 cubic centimeters of water, to

* See this journal, Volume LXX, No. 4, page 51, and Volume LXXI, No. 2, page 301.

which has been added 10 cubic centimeters of phosphoric acid solution. Titrate now with standard permanganate, adding with moderate rapidity at first, then more slowly with constant stirring, until one drop gives the pink color characteristic of the end reaction.

APPARATUS AND REAGENTS.

The apparatus required by this method is simply the beakers, burettes, pipettes, etc., present in every laboratory, and requires no special comment.

The stannous chloride solution is made by adding to one pound of concentrated chemically pure hydrochloric acid one pound of chemically pure stannous chloride obtained in the market. Dissolve by stirring. If all the stannous chloride fails to dissolve after a little time, add enough water to secure solution. Dilute to two liters. The bottle holding this solution should be kept closed when not in use, and a few fragments of metallic tin added to keep the salt reduced to the stannous form.

The permanganate of potash solution for titration is made as follows: To one liter of water add two grams of crystallized permanganate of potash, and allow to stand in the dark not less than a week before using. Determine the value of this solution in terms of metallic iron. For this purpose 150 to 200 milligrams of iron wire or mild steel are dissolved in 15 cubic centimeters of chemically pure hydrochloric acid (1.10 specific gravity). After solution is complete, reduce with stannous chloride, add mercuric chloride, pour into solution of phosphoric acid, and titrate exactly as described above. It is of course essential that the amount of iron in the wire, or soft steel, should be known. The standard in use in the Pennsylvania Railroad laboratory is a mild steel in which the iron is known by determining carbon, phosphorus, silicon, sulphur, manganese and copper, and deducting the sum of these from 100 per cent. Not less than two independent determinations should be made, and three are better. The figures showing the value of the permanganate solution in terms of metallic iron should agree to a hundredth of a milligram in the different determinations. A very satisfactory method of making and keeping permanganate of potash solution is as follows: Have a large glass bottle holding say eight liters, and two of half the size. Paint the outside of these bottles with several coats of black paint or varnish. Fill the large bottle with the standard solution, and after it has stood a proper time fill one of the smaller bottles from it without shaking and standardize. At the same time fill the second small bottle, and refill the large one. When the first small bottle is exhausted standardize the second one and fill the first from the stock. When this is exhausted standardize the first again and fill the second from stock, refilling again the stock bottle and so on. By this means a constant supply of sufficiently matured permanganate is always available. Of course if the consumption is very large, larger bottles or more of them may be required. Since changes of temperature affect the volume of all solutions, it is desirable that the permanganate solution should be used at the same temperature at which it was standardized. With the strength of solutions above recommended, if the permanganate is used at a temperature of 20 degrees Fahr. different from that at which it was standardized the error amounts to less than 0.05 per cent. in a pigment containing 80 per cent. of sesquioxide of iron.

The mercuric chloride solution is made by adding to a bottle containing about a pint of distilled water two ounces of chemically pure mercuric chloride, filtering if necessary. A saturated solution is desired for use and the above amount of mercuric chloride is sufficiently in excess, so that water can be added from time to time.

The phosphoric acid solution is made as follows: Add 160 grams of chemically pure manganous sulphate, obtained in the market, to sufficient water, and when solution is complete dilute to 1,750 cubic centimeters. Then add 330 cubic centimeters of syrupy phosphoric acid, 1.70 specific gravity obtained in the market, and 330 cubic centimeters of concentrated chemically pure sulphuric acid. Mix thoroughly, filter if necessary, and keep in a well-stoppered bottle.

CALCULATIONS.

An example of all the calculations is given herewith. The soft steel employed in standardizing permanganate of potash solution in the Pennsylvania Railroad laboratory contains 99.27 per cent. metallic iron. 0.1498 gram of this contains therefore (.1498 \times .9927) .1487064 gram of metallic iron. This requires 42.99 cubic centimeters permanganate solution, or 1 cubic centimeter of permanganate solution is equal to (.1487064:42.9) .003466 metallic iron. But metallic iron is to sesquioxide as 112 to 160 (Fe_2 to Fe_2O_3). Hence 1 cubic centimeter of permanganate is equal to (112:160 :: .003466 : \times) .004951 sesquioxide of iron. Twice the number of cubic centimeters used in the analysis, since half a gram is taken, multiplied by this factor, gives the sesquioxide of iron in one gram of the pigment, and this multiplied by 100 gives the percentage.

NOTES AND PRECAUTIONS.

It will be observed that this method is almost exactly the Zimmerman-Reinhardt method, described by Mixer and Dubois in the *Journal of the American Chemical Society* for May, 1895. In our hands the method has given such admirable results that we use it wherever possible.

The pigment frequently adheres with considerable tenacity to the sides and bottom of the flask used in separating it from the other constituents of the paint. Moreover, the constituents of the pigment separate from each other in the gasoline solution, the heavier particles being at the bottom. It would lead to error, therefore, to take sufficient material for an analysis out of the flask without previous care to secure a uniform sample. The flask should be well cleaned, and the whole amount thoroughly mixed before weight is made.

Pigment separated from oil by means of any solvents is apt to contain some organic matter, possibly oxidized oil, or traces of the unoxidized oil, not removed. Moreover, the passenger car color pigment contains as an essential constituent organic coloring matter. These substances interfere with the subsequent titration with permanganate, and must accordingly be removed. This is apparently easiest done by ignition as described. If very high temperatures are used, the subsequent solution will be more difficult.

The use of stannous chloride to facilitate solution and also to reduce the iron requires some precautions. The more stannous chloride there is present before the mercuric chloride is added, the more of this latter reagent must be added to decompose it, since it is impossible to titrate in presence of stannous chloride. But the more mercuric chloride added to decompose stannous chloride, the more mercurous chloride there is present in the solution to be titrated. Experience shows that this mercurous chloride may lead to erroneous results in the titration. If the material to be titrated is opalescent only from suspended mercurous chloride, entirely satisfactory results may be expected. If, on the other hand, a voluminous precipitate of mercurous chloride is present, the results may be seriously in error, possibly due to a reaction between the mercurous chloride and the permanganate.

The use of the phosphoric acid solution enables the titration with permanganate to be made in presence of hydrochloric acid, and thus avoids displacing this acid by sulphuric, and the use of the reductor, which are characteristic of the older methods. Apparently the manganese sulphate is the important factor in this possibility, the phosphoric acid being added to give a colorless solution, so that the end of the reaction may be observed with sufficient sharpness.

It will not escape notice that if the manganese sulphate, the phosphoric acid, or the sulphuric acid, used in making the phosphoric acid solution, any or all of them contain iron in the protoxide form, or even organic matter, an error may be introduced in the titration. It is well, therefore, to test this solution with permanganate before using it. If the same amount that is required for an analysis uses up more than one, or possibly two drops of permanganate, the amount actually so used up must be deducted from the figures obtained in the regular titration.

Belpaire Stationary Boilers—Grand Central Station, New York.

The general arrangement of the improvements in the Grand Central Station in New York were illustrated in the AMERICAN ENGINEER, CAR BUILDER AND RAILROAD JOURNAL of March, 1897, page 104. The statement was made at that time that this station would be one of the best appointed in the world when completed, and the work that has so far been done confirms that opinion.

The plans include a new power plant which is to furnish the steam and electric power and the steam for heating and the disposition of this plant in the basement of the building without

making extensive and expensive changes was interesting and rather difficult.

The steam plant is situated opposite Forty-third street on the Vanderbilt avenue side of the building, and the head room was limited to 10 feet 6 inches, which made the problem of installing 1,500 horse power in boilers an unusual one. No domes could be used and the steam piping was to be kept low. The space was too restricted to admit of using a water tube or a horizontal tubular type of boiler, and after considerable study the Belpaire type was chosen, and the height of the boiler itself was kept down to 8 feet 8½ inches, which will be seen to be remarkably low for a boiler of 208 horse power without resorting to a type that would not be suitable for this purpose. It is by no means unusual for this type to be used in stationary practice, and it possesses distinct advantages over the cylindrical return flue type. The firebox is surrounded by effective heating surface, and the setting is more simple and cheap, and there are no losses due to leaky settings. Boilers of the locomotive type should be carefully insulated by non-conducting coverings, and we are informed that this has been attended to in these boilers.

There are seven boiler spaces provided in the power room, and six boilers will be used. They are designed for a pressure of 150 pounds. The diameter of the shell is 72 inches at the smallest ring, and the length is 22 feet 7 inches. The flues are 398 in number, and are two inches outside diameter by 11 feet long. The tube sheets are ½ inch thick, the crown sheet is ¾ inch thick and the other sheets are ⅝ inch thick with the exception of the throat sheet, which is ¾-inch. It was the intention to make the outside firebox sheet all in one piece, but it was decided to make it in three pieces as shown in the sectional view. The grate area is 45.6 square feet, the firebox being 66 inches wide and 101½ inches long inside. The heating surface is 2,494.3 square feet, of which 2,288.5 square feet are in the flues, and 205.8 square feet are in the firebox. The grate area is 45.6 square feet.

The dry pipe is a wrought iron pipe of 9 inches inside diameter, and is supported near the top of the boiler, as shown in the drawings. The steam enters through 15 two-inch holes in the top of the pipe, and water is allowed to drip from three 3-inch holes in the bottom of the pipe. The steam is led away through a 6-inch pipe and elbow. It will be noticed that a battle plate is hung from the shell in front of the dry pipe, for the purpose of preventing the rush of water to the pipe.

The grates are of the cast-iron stationary type arranged for the burning of "pea" coal. The frames are held by studs on the inside of the firebox. It will be seen from the drawing that the water spaces around the firebox are not uniform, the space at the front being 4 inches. The space at the top of the sides is 5 inches and is 4 inches at the bottom. The space at the top of the end is 4 inches and at the bottom it is 3½ inches. The crown sheet slopes downward toward the rear and it is supported by 1½-inch stays, upset at the ends to a diameter of 1¼ inches. The spacing of these stays is shown in the drawings. The short staybolts are ⅜ inch in diameter and the spacing is also shown in the drawings. The crown and cross-stays are of the same diameter. The flues are set with copper ferrules expanded into both sheets. The boiler is stayed longitudinally by the use of diagonal stays of 1½-inch round rods secured to crow feet at both ends. The form of the seams and the location of the washout plugs and the man-hole are shown in the drawing.

The boilers were built by the Schenectady Locomotive Works, to specifications by Mr. William Buchanan, Superintendent of Motive Power and Rolling Stock of the road, to whom we are indebted for the drawings and information.

1898 Conventions at Saratoga.

We are informed by Mr. John W. Cloud, Secretary of the Master Mechanics' and the Master Car Builders' Associations, that the 1898 conventions will be held at Saratoga, N. Y. The Master Car Builders' convention will open Wednesday, June 15, and the Master Mechanics' convention will open on the following Monday, June 20. The dates have been incorrectly reported by several journals, but the statement given here is based upon official information from Mr. Cloud and is therefore correct. The headquarters will be at Congress Hall.

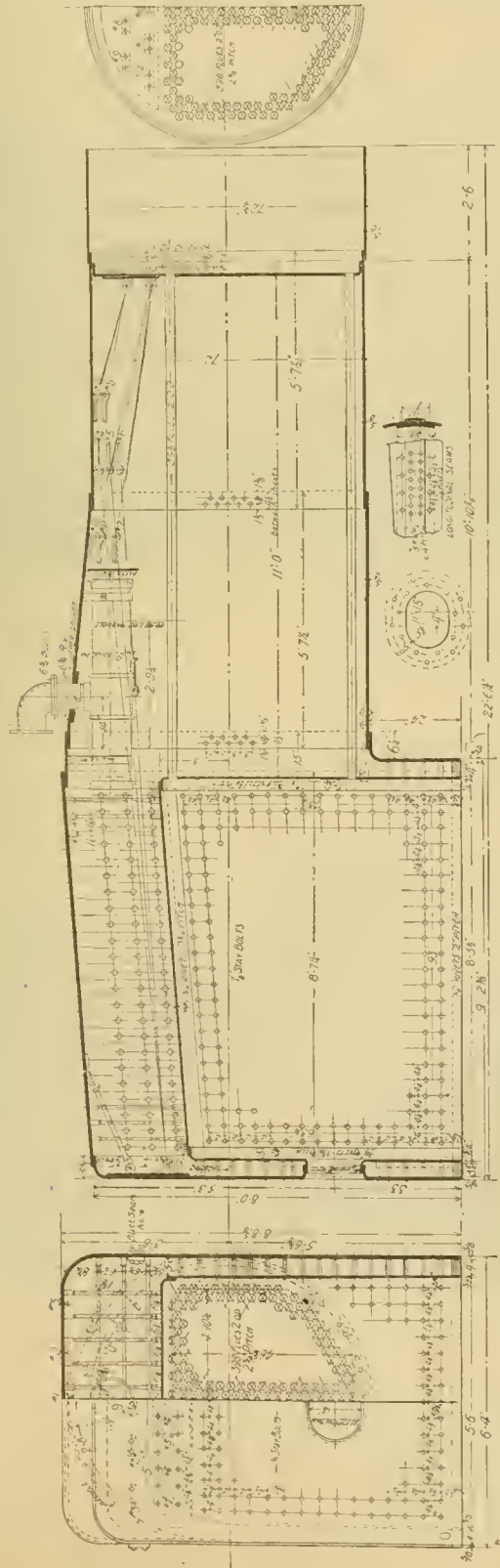

Belpaire Stationary Boilers.—Grand Central Station, New York.

Stone Crusher—B. & O. S. W. Ry.

The Baltimore & Ohio South Western Railway has been using so much crushed stone in the permanent improvements on its lines as to necessitate the installation of a stone-crushing plant at the quarries, which are situated on the Rock Creek branch near Mitchell, Ind. The general appearance of the plant and its arrangement may be seen by the accompanying illustrations, which show it while under construction and after completion.

The quarry is of oolitic limestone and is practically unlimited in extent. It is very conveniently located with reference to the track and the stone is taken out and crushed with very little expense. The first illustration shows the framework and the machinery while it is being placed, and before the quarry was opened; the other view shows the crusher plant complete with the quarry opened.

The plant is divided into three parts: the boiler house, the crusher and the storage bins. The storage bins are over the tracks upon which the cars are run for loading. Steam is furnished by two boilers of the locomotive type and power is obtained by an old engine that was taken from one of the locomotive shops.

The crusher machinery was furnished by the Gates Iron Works, and consists of one No. 7½ and one No. 4 crusher, both being of the Gates pattern. The stone from the quarry is first run through the No. 7½ crusher and is carried by heavy elevators to a revolving screen where the dust and fine stone are screened out and any stone that passes through a 2½-inch hole goes through the screen and into the ballast bin. The stone that has not been crushed fine enough to pass through this part of the screen is run out of the end of the screen and through a rejection spout to the other crusher, where it is re-crushed and re-elevated to the screen. In this way the stone is made of even size, which is essential in the production of good ballast.

The plant is complete in every way, and it is used for the production of crushed stone for many other purposes than for ballast. It will be seen that the quarry is very favorably situated with reference to the crusher with respect to the handling of the material, and while we are unable to state the cost of the working, it is said to be very low. The capacity of the plant when the quarry is completely opened will be between 600 and 700 yards per day; at present it is from 100 to 150 yards per day, and this may be increased at any time by opening up the quarry to a greater extent. We are indebted to Mr. I. G. Rawn, General Superintendent, and to Mr. J. H. Maddy for the photographs and information concerning this plant.

The cupping of firebox sheets to preserve staybolts, referred to on page 321 of our issue of September, 1897, was discussed at the November meeting of the Western Railway Club, the service reports being very favorable.

Automatic Signals.

The subject of automatic signals was discussed at the recent meeting of the Railway Signaling Club in Chicago, it being introduced by a paper by Mr. V. K. Spicer. The conclusion to be reached from the discussion was that there was a growing tendency to look upon automatic signaling as a safe and desirable system. The old objections to these signals are mentioned, and



Stone Crusher—B. & O. S. W. Ry.

among them are the absence of men stationed at the signals to insure their observance by engineers. This was a question of discipline and the confidence which had been imposed in automatic appliances of this kind had been growing.

There seems to be no doubt that there is a specially good field for these signals in this country. The high cost of controlled



Stone Crusher—B. & O. S. W. Ry.

manual systems both for installation and for operation tended to make the advantages of the automatic types stand out prominently. The records which these signals had made were favorable to them and there seemed to be no well grounded objection to them. The question of the relative advantages of the disk and the semaphore types of signals did not receive attention, and in view of recent experience in the use of automatic signals of the semaphore type, as recorded in our issue of last month, and the

fact that all the prominent signal companies are prepared to furnish the semaphore type goes to show that those who prefer semaphores may be supplied with them, and that they may be relied upon. The disk signal has given an excellent account of itself and in fact the reputation of the automatic signal has been made by disk signals.

The conditions which obtain on most of the railroads in this country preclude the possibility of using the controlled manual system even if the necessary investment to install it is available. It is well established that automatic signals can be made to work in a perfectly reliable manner if the necessary care is taken in the construction of the apparatus and in the installation. Much has been learned in regard to the best methods of wiring and arranging the circuits with reference to ease of inspection and repair, so that it may now be said that the protection afforded may be complete. So much more signaling of the automatic type may be obtained for one's money that the cost factor cannot be neglected, and while some say that cost should not enter into the question of railroad signaling the fact remains that it does enter and, more than that, it stays in the question. Those who do not believe that it is the legitimate function of signaling appliances to pull a drunken or otherwise incapacitated engineman off his engine for disregarding its indications and discipline him forthwith are inclined to think that the automatic devices are on the whole more reliable than the manual. After all is said, the manual systems, even if they are locked or "controlled," must rely upon automatic devices almost as much as the purely automatics, and when these locks fail or become "tied up," as they sometimes do, the case of the manual is worse than that of the purely automatic. We are of the opinion that the controlled manual system will not make very much headway in this country.

Permissive working must at times be resorted to under the controlled system, and we ask: Is it not better to put in automatic signals and make the blocks so short as to take permissive working out of the question altogether?

The most recent development of automatic signals which is arranged upon the normally danger plan, as described in our December, 1897, issue, is worthy of study, and if in experience it bears out expectations we believe the type of signals represented will find favor.

The Raddatz Submarine Boat.

We record the appearance of a new submarine boat designed and built by Mr. Richard Raddatz, of Oshkosh, Wis., which has been undergoing experiment in Lake Winnebago, at that city. It is understood that the boat is propelled by a hot air engine when running on the surface and by an electric motor and accumulators when under the surface. The method of supplying air to the occupants has not been explained by Mr. Raddatz.

In view of the interest which has been taken in submarine boats, we have obtained a statement from the inventor with regard to the performance of the craft and reproduce it in his own words as follows:

This craft is cigar-shaped, 65 feet long, 4 feet in diameter and 7½ feet high at the highest point. It is built of ½-inch armor steel on a heavy steel framework, and is estimated to be of sufficient strength to withstand the pressure due to a submergence of 500 feet. The forward end of the boat is armed with a heavy steel spur capable of doing considerable damage. At the rear end is a two-bladed 30-inch propeller wheel. Projecting beneath the boat, at the stern, near the propeller wheel, is a long steel rudder, capable of turning the boat in twice her length. The weight of this craft ready for service is somewhat over 31 tons. She has attained a surface speed of about 14 miles an hour with an expenditure of from 40 to 45 horse-power. When under water the craft is propelled at a rate of from one to ten miles an hour by electricity. It is easily capable of completely disappearing beneath the surface of the

water from surface condition in about 60 seconds, and has accomplished this during a test made to determine this question in 18 seconds. It has, likewise, in the same short space of time been brought to the original surface condition.

With three men on board it has remained under water for over three hours at a time without the least inconvenience to the inmates or any ill after effects, the passengers declaring that as far as the condition of the atmosphere in the boat was concerned, they were willing to have remained down another three hours. On one day of 10 hours, 8½ hours were spent under water, the air being maintained in a pure condition during this length of time with three and four passengers on board, demonstrating clearly that with two passengers the boat can remain submerged for 20 consecutive hours with no ill effects. During all the tests made the air machinery has shown itself capable of supplying in proper quantities all the air needed, not only for respiration but likewise for the supply of three ordinary sperm candles used for illuminating gages and indicators. During another test, lasting for over three hours, with three men on board, and made to determine the capability of the vessel to maintain a level keel, it was shown that the air bubble in an ordinary spirit level would not vary at all from the level-mark to show that the vessel had been in any way tilted or inclined. To demonstrate the capability of the vessel maintaining itself at a constant depth, passengers inside the boat checking off the depth on an external manometer and observers stationed in service boats supplied with graduated rods and having connection with the boat by means of ropes marked to show the depth, proved, by their observations, that a constant depth was maintained for a period of over one hour with almost no variation as far as they could detect by the means employed. During the experiments over 300 descents have been made. After the first half a hundred trials no accidents whatever have occurred. Between 60 and 70 different people have been taken for



The Raddatz Submarine Boat.

more or less extended voyages beneath the surface, in every case resulting to the complete satisfaction of the passengers.

It Was Play For Him.

The train ran off the track and plunged down a steep embankment.

Engine, baggage car, coaches and sleepers were jumbled in one awful mass.

The groans of the injured passengers rent the air.

It was frightful!

Jones, the world-renowned halfback, partially awoke.

Three passenger cars were piled on top of him.

A piece of pipe was coiled around his neck.

The rim of one of the great driving wheels of the engine rested on his face.

His legs were pinned down by a heavy beam.

A pillow had been forced against his mouth and nose, making it impossible for him to breathe.

His arms were pressed against his sides and he tried in vain to move.

But willing hands were at work upon the wreck, and at last Jones, the world-renowned halfback, was dragged out.

Looking around in a dazed sort of way, at his rescuers, he asked: "How many yards did we gain on that 'down,' boys?"—*Cleveland Leader.*

M. C. B. Standards in Repairs.

By a recent decision of the Arbitration Committee of the Master Car Builders' Association, more prominence is given to the admissible use of the M. C. B. standards in place of original parts, even though the standards differ considerably from the originals. The case in question (No. 496) concerned a broken oil box replaced by an M. C. B. box to a Southeastern Line car by the Chicago & Eastern Illinois Railroad. The Loutbestern people claimed that the repairs were wrong, inasmuch as the boxes differed as regards lips for the arch bars, but the decision favored the use of the standard.

(Established 1832.)

AMERICAN ENGINEER

CAR BUILDER AND RAILROAD JOURNAL.

29TH YEAR.

67TH YEAR.

PUBLISHED MONTHLY

BY

R. M. VAN ARSDALE,

MORSE BUILDING.....NEW YORK

G. M. BASFORD, Editor.

JANUARY, 1898.

Subscription.—\$2.00 a year for the United States and Canada; \$2.50 a year for Foreign Countries embraced in the Universal Postal Union.

Subscriptions for this paper will be received and copies kept for sale by the Post Office News Co., 217 Dearborn Street, Chicago, Ill.

EDITORIAL ANNOUNCEMENTS.

Advertisements.—Nothing will be inserted in this journal for pay, EXCEPT IN THE ADVERTISING PAGES. The reading pages will contain only such matter as we consider of interest to our readers.

Special Notice.—As the AMERICAN ENGINEER, CAR BUILDER AND RAILROAD JOURNAL is printed and ready for mailing on the last day of the month, correspondence, advertisements, etc., intended for insertion must be received not later than the 20th day of each month.

Contributions.—Articles relating to railway rolling stock construction and management and kindred topics, by those who are practically acquainted with these subjects, are specially desired. Also early notices of official changes, and additions of new equipment for the road or the shop, by purchase or construction.

To Subscribers.—The AMERICAN ENGINEER, CAR BUILDER AND RAILROAD JOURNAL is mailed regularly to every subscriber each month. Any subscriber who fails to receive his paper ought at once to notify the postmaster at the office of delivery, and in case the paper is not then obtained this office should be notified, so that the missing paper may be supplied. When a subscriber changes his address he ought to notify this office at once, so that the paper may be sent to the proper destination.

The paper may be obtained and subscriptions for it sent to the following agencies: Chicago, Post Office News Co., 217 Dearborn Street. London, Eng., Sampson Low, Marston & Co., Limited St. Dunstan's House, Fetter Lane, E. C.

The American Society of Civil Engineers formally opened the new house on West Fifty-seventh street, New York City, November 24, with exceedingly interesting and appropriate ceremonies which constituted a marked recognition of the services of the engineer in the world's progress. The new home of the Society is exceedingly handsome and is admirably adapted to its purpose. We congratulate the Society on this event, which undoubtedly will mark the beginning of a new era in its honorable and useful career.

A few years ago any suggestion looking toward a decrease in the illuminating power of locomotive headlights would have received scant courtesy from railroad men, and, out of the high regard for strong illumination ahead of the engine, electric headlights came and for a time made considerable progress. With the advances in signal protection and the isolation of the right of way a change has come, and there is a marked tendency to regard electric headlights as an element of danger rather than of safety. As a prominent Master Mechanic puts it, "The electric headlight at best only gives an engineer time to get scared when he sights an obstruction," and he advocates the use of smaller headlights. There is a question of cost to be considered in connection with even the ordinary style, for, as Mr. Sanderson says

in his paper recently read before the New York Railroad Club, a saving of from \$6.50 to \$10.50 per engine may be made by substituting a 16 or a 12-inch headlight for the 23-inch size. Mr. Sanderson says: "There is a positive danger in using a very brilliant and powerful headlight, such as some of our electric friends are interested in, for the reflected glare off the surface of the switch lamp lens is often so great that it entirely overpowers the light coming from the lamp, and will show apparently white light to the engineman while the signal may be standing at red or green. For safety a runner must therefore look for the position of a target or semaphore and not trust to the lights at night."

Comparatively little is known about the effects of changes in the ratio of expansion in multiple expansion engines, yet this must be considered as one of the most important items in the design of such engines. It is worthy of note that there is a wide difference of opinion among the different locomotive builders as to the best ratio between the cylinders of compounds, and it is to be hoped that information will soon be available to enable designers to work intelligently in this direction. The ratio of expansion troubles marine and stationary engine builders quite as much as it does the locomotive men, and this subject was one of the most interesting and valuable of all those brought before the recent meeting of the American Society of Mechanical Engineers. Professor Thurston, in his paper entitled "Multiple-Cylinder Steam Engines, Effects of Variation of Proportions and Variable Loads," describes tests upon a Rockwood type of compound stationary engine having a cylinder ratio of 7 to 1. The tests were made upon a triple engine of which the intermediate cylinder was omitted, giving the ratio stated. This resulted in a surprising economy. The triple expansion engine worked most economically under a load of about 115 horse-power, but the 7 to 1 compound used less steam at all loads under 85 horse-power. It also used less steam than a compound engine having a ratio of 3 to 1 at all loads above 72 horse-power. The Rockwood compound has been known to give high economy, but it has been thought to be accidental until these experiments showed that there is more than accident to account for the economy. We cannot tell where this will lead us, but it is very likely to exert an influence upon the future of the multiple expansion engine. More data are needed, and it is probable that more work will be done in this direction in the near future.

The Interstate Commerce Commission has taken action on the petition of the railroads in the matter of an extension of time for the equipment of cars with automatic couplers and air-brakes in what must be considered a very satisfactory way. The time has been extended two years and this will give all of the roads sufficient time to comply with the requirements. The arguments of the roads brought out the fact that the condition of the railroad business since the passage of the act has been a serious obstacle in the way of many of them. Another reason for an extension of time was the hardship that would be occasioned if the cars not equipped should be prevented from being used in interstate traffic. This would cause such a scarcity of cars as to seriously embarrass shippers. It is by no means to be inferred that the Commission in extending the time for a period of two years is to be lenient in the matter of carrying out the provisions of the law, and while there will probably be no conditions in the extension, a careful watch in the form of equipment reports will be kept as to the progress made by the roads, and it behooves the roads to make all the progress possible in the matter. The railroads wanted an extension of five years and at first the Commission was inclined to grant an extension of only one year. Neither of these propositions seems to be as wise and fair as the one that was finally agreed upon, and with good prospects for business there should be no difficulty in completion of the applications of the couplers and air-brakes in that time. There is an additional reason why the roads should use every effort to put on air-brakes and automatic couplers as rapidly as possible, in that cars thus equipped may be operated more economically than at pres-

ent, owing to the fact that the coupling together of automatic and non-automatic couplers causes much more expense for maintenance than when the couplers are uniform, and also the best use of air-brakes cannot be had unless all or nearly all of the cars of the trains are equipped with them. The railroads are to be congratulated upon the decision that was reached by the Commission.

TROLLEY CAR ACCIDENTS.

The frequency and the serious character of the accidents occurring on the street railroads which are in so many cases paralleling steam roads calls attention in a forcible way to the dangers of present day street railroading and the comparative safety of travel by the substantial roads. The papers which came into our office in a single day recorded three accidents to trolley cars each attended with fatal results, and we think it time to call attention to the fact that it is dangerous to play with fire. It is high time to look out for the future, because accidents, in all probability, will increase faster than the growth of business. We submit that the trolley roads are not properly protecting their passengers, taking this ground on account of the absurd things that are commonly done on these roads that would not be countenanced upon trunk lines for a moment. The first requisite is good management and discipline, and the next is better safety and braking appliances; how absurd it is to think of applying the brakes of a heavy motor car with the slow crank handle and how iniquitous it is to permit the use of chilled brakeshoes in any service for the sake of the great durability thus obtained! These roads will soon be faced by the wrath of an enraged public if their ways are not mended. This is no excuse for the irresponsibility of the methods often followed on the street lines. The steam roads have learned to regard the safety of their patrons, and they, for the most part, are trying to provide the maximum of safety, while a great indifference and an implicit trust in the kindness of Providence is apparent in the methods of street and electric lines. The speculative features of these railroads would not suffer by the employment of correct principles of railroading, but would be improved by them. It has already been noted in these pages that an act to place the inspection of the street lines as well as the steam roads under the care of the State Railroad Commissioners has been passed in Massachusetts, and other States must follow if the initiative is not taken by the roads themselves. Conditions in street car traffic have changed with astonishing rapidity, and the fault is that methods of operation have lagged far behind the necessities of the case. The public makes its demands; known to the trunk-line railroads in short order when accidents occur, and why the street lines are not held up to the same standard of safety in operation is unaccountable.

STEEL FREIGHT CARS—M. C. B. DESIGNS.

Numerous signs point to the fact that we have, in this country at least, reached the steel car age. The years 1896 and 1897 will be notable as the time when steel car construction in the United States was first undertaken in a serious manner and placed on a commercial basis. In 1896 sufficient experimental work was done to enable a committee of the Master Car Builders' Association to present a report confidently recommending certain forms of construction and illustrating them with fairly good designs. At the 1897 convention another committee recommended three different designs for underframes for 30-ton cars, one of which (we will designate it as Type A) had no truss rods; one (Type B) had wooden end sills, wooden draft timbers and small wooden longitudinal stringers bolted to the long channels; while the third (type C) had neither buffer blocks nor buffers, the draft rigging being attached to suspended plates riveted to the center channels. In order to bring the work of the committee into some uniformity certain principal inside dimensions of the box car were agreed upon and it was suggested that they be submitted to letter ballot as a recommended standard of the Association. This portion of the report was adopted and approved by letter bal-

lot; and the recommended standard of the M. C. B. Association for the general dimension of a box car with steel underframe is as follows:

Inside length and width, 34 feet by 8 feet 1 inches.

Height from rail to top of floor, 4 feet 2 inches; from floor to plate, 7 feet 6 inches.

Side door, 5 feet 4 inches; end door, 24 by 36 inches.

End sill flush—not projecting.

These dimensions have to do chiefly with the upper framing, and might have been very useful for wooden cars if adopted years ago; but we believe they will be of little use for cars with steel underframes, for it is likely that few steel cars of 60,000 pound-capacity will be built, and when steel is introduced advantage will be taken of its superior strength and the car capacity will be increased to 70,000 or 80,000 pounds for grain cars, and they will of necessity be made of greater length. The further action of the M. C. B. Association on the subject of steel cars was the appointment of a new committee to study the designs already presented and obtain criticisms upon them, and, if possible, to recommend a design for adoption. This committee has just sent out a circular of inquiry, in which they ask: What parts should be made of wood? Are independent draft timbers recommended? Should wooden end sills be used? What type of center-plates and side-bearings should be used? We shall take up some of these questions and discuss them briefly in connection with a criticism of the plans in the 1897 report, and with a general consideration of the subject of steel cars.

Of the three designs for steel cars presented at the 1897 convention, we would favor the one without truss rods and with deep centre sills, which we have designated as type A. This car has the draft rigging strongly riveted to the center sills, so that compressive and draft shocks are transmitted directly through them, and there is no tendency to deflection, as must be the case if the compression stresses are applied below the sills, as in all other designs in which suspended draft timbers or plates are used. We regard this principle as fundamental, and it is a mistake not to take advantage of it, as can be so easily done in steel car construction. The design, type A, has a steel-channel end sill, with a substantial oak buffer block, 7½ inches thick, to which cast iron buffers are attached. This amount of timber ought to provide a sufficient cushion for buffing, and it should prevent the rigid transmission of shocks to the rivets which is so much feared by some in regard to steel cars. The other two designs show extreme conditions in their provisions for this action—type B having a wooden end sill, wooden draft timbers and wooden buffer blocks, but no buffers, while type C shows neither wooden buffer blocks nor cast buffers—and yet we have the statement of the designer that the car has been in service five years without any expense for repairs. With a good oak buffer block we do not believe it is necessary to have a wooden end sill in steel cars, and a much more substantial design can be made without it.

The principal meritorious features in the design type A are as follows: (1) The car weighs less than a wooden car of the same general dimensions, and is much stronger. The weight of the steel frame is 6,959 pounds and the wooden joist for attachment of wood floor, bolts, etc., weighs 962 pounds, making a total of 7,922 pounds, while corresponding parts of a wooden car weigh 9,626 pounds, a difference in favor of the steel frame of 1,704 pounds.

(2) Only commercial shapes are used allowing competition in purchase of material.

(3) Every part is easily accessible for inspection and nearly all rivets can be driven by power.

(4) The main strength is in the center sills, which are 15 inches deep.

(5) Vertical strength is provided with moderate weight without the aid of truss rods.

(6) The draft gear is between the center sills and directly attached to them.

The whole design of type A is intended to secure horizontal rigidity, with the idea that distortion is not admissible in steel construction, and if provided for cannot be regulated within the

limit of elasticity of the material. The elastic resistance should be in the springs and wooden buffer blocks, where shocks are first received, and not in the frames. To make a car flexible without cracks it must be made largely of wood. This is the principle upon which type B has been designed. It has good sized wooden side sills attached to the side channels, wooden end sills and draft timbers and truss rods. The car seems to have been designed with the idea of giving it constant repairs, and we believe that if cars were built upon that plan the cost of repairs would be more than for ordinary wooden cars. The objections to type C are (1) the very light channels, (2) the use of truss rods, (3) the suspension of the draft gear below the center sills, (4) the absence of buffer blocks and buffers.

In the discussion of the three M. C. B. designs for steel cars we have incidentally answered some of the questions asked by the committee. (1) The only wooden parts necessary on a steel underframe are sufficient joist for the attachment of the floor and substantial buffer blocks; wooden end sills are not necessary. (2) Truss rods are not necessary, and the equivalent weight of metal could be better employed in deeper center sills. (3) Independent draft timbers are not admissible, and we believe them to be the very things to get rid of in steel cars.

In further support of the idea that truss rods should not be required in steel cars, we call attention to the tests of the 80,000-lb. flat car constructed by Mr. Peanock in 1895, and used in severe service at the works of the Carnegie Steel Company about one year. The car was then tested at the works of the Universal Construction Company, Chicago, by placing a load of 140,000 pounds of pig iron between the truck centers, giving a deflection of only $1\frac{1}{2}$ inches at the center. A load of 159,000 pounds was distributed on the car by placing 45,000 pounds at each end and 69,000 pounds in the center portion, resulting in a deflection of $\frac{1}{2}$ inch at the ends and $\frac{3}{8}$ inch at the center. Under all these severe conditions the elastic limit of the metal had not been reached. The car weighed only 22,620 pounds. The Harvey steel flat car of 60,000 pounds capacity, with truss rods, tested at the same works, weighed 24,080 pounds and under a load of 119,000 pounds distributed between the truck centers it deflected $1\frac{1}{8}$ inches. The conclusion we would draw from these tests is that the car without truss rods weighed less and deflected less under a greater load similarly located.

The other two questions in the circular of the M. C. B. Committee relate to center plates and side bearings, and these we regard as among the most interesting and vital matters of detail which will be rapidly developed by the use of steel cars of large capacity. It is surprising to find that in the 100,000-lb. steel cars, now building, the center plates are of the ordinary form and the area of the bearing surface has been enlarged to a very slight degree above those in 60,000-pound cars. Under such conditions we should expect the frictional resistance to curving to be very great, and sufficient to cause rapid flange wear and increased train resistance. It does not seem to be good mechanical construction to place two rough or unfinished soft steel disks about 12 inches diameter together under a load of 70 tons and expect them to rotate easily. The service is similar to that of a locomotive turntable, where, with a lever-arm about 12 times that on which the truck acts, there is proper provision for friction at the center bearing. These bearings are of several types; one most generally used consists of a nest of conical roller bearings made of hard steel placed in a steel case and all carefully finished. Another form employs disks 8 or 10 inches in diameter, having a slight concave and convex surface, one made of steel and the other of bronze. For large-capacity cars some such form of center bearings should be used, and they could be made cheaply by casting the cones or disks of hard steel and grinding to size. This is our recommendation for center plates, and the side bearing should have attention as a matter of rational design to make it properly fulfill its function. In the present article we have considered the steel car in connection with the work of the M. C. B. Association and have not allowed ourselves space to point out the economic features of the subject, which relate to large capacity and weight, first cost, deterioration by corrosion

and repairs, but we hope to discuss these features in our next issue.

Y. M. C. A. INFLUENCE IN RAILROAD WORK.

One of the greatest and most permanent of the advances of recent years in railroad matters is the great change which has begun and is now at work in the direction of applying the principles of sociology to the relations between officers and men. Some of the most significant indications of a deep interest on the part of officers in their subordinates are the rapid strides which have been made by new methods of discipline, and by the rapid growth of the Railroad Young Men's Christian Association idea. There are other indications which may be traced to the Y. M. C. A. movement, and it may be said that even the improved discipline is a direct result of its influence.

That there should be a high moral standard among railroad men has always been urged, but that the roads themselves had any obligations to the men in assisting to keep the standard high by surrounding them with influences tending to make it easier to retain good moral character amidst the temptations of the rough and ready life has not always been so clearly seen. Saloon influences and transportation responsibilities are incompatible, and officers are not only justified in discharging men who frequent saloons, but it is their duty to do so. Their duty, however, is not done unless other influences are furnished which will counteract those of the saloon and render them less dangerous because less attractive. The way this may best be done is to provide convenient, attractive and homelike quarters for the use of the men during their spare time and to surround them with good influences, and those educational advantages which are more appreciated by railroad men than by any other class.

There would be no labor problem if the idea of the Y. M. C. A. could be carried out among the men and among the officers. It is not alone the religiously inclined who are affected by the effort to place the men among pleasant surroundings and to give them educational facilities, but it is the religious influence that makes this movement so powerful. Its influence is to give men a view of their responsibilities in life, to show them the advantages of thrift, to educate them in connection with their work, and by bringing them together it helps them to become acquainted with their companions and shows them phases of the lives of their comrades which they would not otherwise see. It makes them more contented and tends to reduce the class of floating railroad men who owe allegiance to no friendly set of officers, and herein is a feature to be specially thought about. The officers can get better service from men with whom they are acquainted and in whom they are interested, and it is by no means the subordinates only who are benefited. The officers need improving quite as much as the men, and as Mr. H. D. Judson says, "One way to have more conscientious men is to have more conscientious officials who know their men and appreciate their fidelity to duty."

An indirect effect of this movement is seen in efforts which are made by several railroads to get their men to take shares of stock by a system of small payments. This is desirable because it touches the family life of the men, and that which they trust to the extent of investing their savings must then command their interest and conscientious efforts. Some officers believe in the Y. M. C. A. only because of its effects upon the earnings of the road. It certainly must affect them favorably, and we only ask such officers to come into close touch with the men through this instrumentality, in order to learn that which they sadly need to know, viz., that there is a success greater, more satisfactory and more honorable than any that may be measured in terms of dollars and cents.

A great many interesting facts concerning the Y. M. C. A. movement were brought out in the addresses at the recent 25th anniversary of the Railroad Branch of the Young Men's Christian Association at Cleveland, when it was stated that the idea was inaugurated at Northfield, Vermont, in 1850 by the establishment of a library for the employees of the Passumpsic Railroad. If

space permitted, an interesting and remarkable growth might be outlined, but that the movement has the support of the best and most successful railroad men is shown by the records of their opinions as they were shown at the occasion mentioned. Mr. Cornelius Vanderbilt expressed this opinion at the second convention, held 18 years ago, in the following words:

"I have for years felt the deepest interest in this work and believe that its importance can hardly be overestimated, both to the men and the companies in whose service they are. It educates and spiritualizes; it promotes economy and thrift; it brings railroad men together, with surroundings and discussions which produce the happiest results to themselves, their families and their employers."

The custom of providing meeting rooms for lectures and instruction is carried out to a considerable extent in England and we are rapidly waking up to the necessity for them as is shown by the ease with which the Chicago & Northwestern Railway has accomplished the erection of its new building in Chicago. Mr. Wm. Thaw, Vice-President of the Pennsylvania Lines West of Pittsburgh, was quoted, in regard to such rooms, as saying:

"I wish to assure you of my deep interest in the work and my desire to co-operate in establishing and maintaining at every point where employees are thrown together in considerable numbers just such a room as you have in the depot at Columbus. It is wholly good both for the men and the roads they serve."

The late President Roberts of the Pennsylvania was a staunch supporter of this work and with his clear understanding and accurate judgment he foresaw a great future before it. In laying the corner stone of the Pennsylvania Railroad branch in 1893, he said:

"For over forty years I have been laying corner stones for the Pennsylvania Railroad, but I never laid one for a building that means so much for this company and its employees as this corner stone for the Pennsylvania Railroad Department of the Young Men's Christian Association."

These paragraphs would not be complete without including some broad ideas which were expressed by Mr. E. T. Jeffrey, President of the Denver & Rio Grande, in an address to one of these organizations in saying that he had formerly thought it an impossibility for the operating of a railroad to have anything in common with religion or Sunday observance. He had changed his views and he was ready to say that, all sentiment aside, the railroad that was operated by a religious set of men was better off than one with an immoral and irreligious set. His words were:

"I am willing to stand anywhere in the United States and challenge contradiction from all quarters and all sides to that assertion. In considering and determining on right lines what is due between man and man, what is due by corporations to employees what is due from employee to corporation, in trying to look with clear-cut vision as to what is the right thing to do, the man who is actuated by Christian spirit and imbued with Christian love, and who is guided in the matter by Christian faith and teaching, is the one most competent to decide correctly."

He who comprehends Mr. Jeffrey's meaning and who puts it into effect will solve for himself the labor problem, and will exert an influence which is needed in the conduct of railroad and all other branches of business.

Specifications for Machine Tools.

The desirability of buying machine tools upon a guarantee of the manufacturers that they will meet certain definite requirements was shown by Mr. J. W. Gardner in a paper recently read before the Western Railway Club. For years it has been customary for the builders of engines and boilers, steamships and warships to guarantee their product to meet specified tests, and, of late the same practice has been carried out in the purchase of locomotives with the natural result of greatly improving the product in each of these lines, and it is likely that the same experience will follow the practice of specifying the work to be performed by machine tools.

Mr. William Forsyth has made the valuable suggestion in this connection, that the tool makers ought to state the specifications

in terms of the weight of the material which the tools will remove in a given time, thus giving a more intelligent idea of the capacity of the machine than may be had by a statement of the capacity in terms of feed in feet cut per minute. The question of whether the manufacturer or the purchaser is to make the specification does not seem to be important, but the capacity when stated in such positive terms would give an excellent basis for intelligent comparison between different machines. Probably the manufacturer would be able to give a more valuable opinion on this subject than the purchaser, and it is fair to expect that one who is prepared to say what his machines can do will be able to sell them better than one who can not. The idea of specifying the weight of metal which a machine will remove was evidently suggested to Mr. Forsyth by his observation of an English lathe, of which he said:

"I saw at the works of Hulse & Company, in Manchester, England, a large gun lathe which had four tool posts, with a screw in the center, and they told me that each one of these tools would remove 500 pounds of steel per hour, so that the capacity of that lathe was the removal of one ton of steel an hour. That gave me an idea of the capacity of the tool. In stating the cutting speed of a tool we give it in linear feet. We say a tool should travel 20 linear feet per minute, but we do not say anything about the depth of the cut, and that is where the power and efficiency of the tool come in, and when we combine the rapidity of the cut with the maximum depth of the cut, we get a measurement of the efficiency of the machine tool. This is really specifying the weight of the shavings to be removed, so that it seems rather a simple thing to make a specification for a machine tool based on the weight of cast iron or steel or brass which that tool will remove."

It is a simple matter for a manufacturer to ascertain the number of pounds of the various metals that may be removed in a given time by one of his machines with a tool of a given size and shape and one who can show that the machine he builds will do several times as much as old tools in a given time has a good argument as a basis for selling, and the purchaser will be able to profit by knowing exactly what he has purchased. The result ought to be a great improvement in shop practice.

Many questions pertaining to the relative advantages of the planer, the lathe, the boring mill and the milling machine for certain work could be settled by having these figures together with the cost of setting the work in each of the machines. One superintendent of motive power is on record as believing it to be possible to increase the output of old tools to such an extent as to cut the cost of repairs in halves. Whether he is exactly correct in his figures or not does not matter since the admission is made that a very large saving is possible even without the introduction of new equipment. In view of this fact it would appear to be worth while to experiment with the tools now in use with a view of ascertaining the amount of metal each can be made to cut away in the same length of time. In considering the purchase of new equipment this would give the officer the advantage of knowing how much he could afford to spend for the new machine which is necessary information. The capacities of machines must also be known in establishing piecework and there seem to be good reasons for believing that an inventory of the maximum output of each machine, new or old, would be a valuable possession.

NOTES.

The method of "laying" dust by sprinkling the roadbed with oil, successfully used by a number of roads during the past year, has been taken up by the New York, New Haven & Hartford on 11 miles of track.

A motor wagon driven by an oil engine has given what appears to be very satisfactory service for the post-office department in London for several weeks. The work is severe, and according to *Transport* the time made by the power wagon is shorter than that of the horse wagons, and the vehicle is likely to become a part of the "permanent staff."

Brown's discipline has been adopted on the Chicago, St. Louis, Amboy and Springfield divisions of the Illinois Central R. R. A

reprimand will be balanced by a clear record of three months; five days of suspension will be balanced by a clear record of nine months; 30 days will be balanced by a clear record of one year, and 60 days by a clear record of 18 months.

Two water tube boilers of the Haythorn type are to be used on a passenger steamer building on the Clyde. They will work under forced draft, with a closed stoke hold. According to *Engineering* each will have 1,700 square feet of heating surface, and furnish steam of 200 pounds pressure, to be reduced to 140 pounds at the engines.

The North German Lloyd ship, *Kaiser Wilhelm der Grosse*, beat the Southampton record on the trip arriving at that port November 29. The time from Sandy Hook to the Needles was 5 days 17 hours and 8 minutes, and the average speed was 23.35 knots per hour. The best eastward record previous to this was 17 hours and 6 minutes longer. The daily runs were 40t, 520, 513, 528, 535, 507 and 71 knots.

An oil-distributing projectile for use on ships has just been patented. It consists of a hollow shell filled with oil and shaped like a rifle projectile. It is intended to be thrown ahead of a ship that is in distress from rough seas, and upon striking the water the oil charge slowly oozes out through a series of small openings controlled by a valve that opens when the projectile strikes the water. By throwing these shells ahead of the ship while moving it is expected that headway may be made against the roughest seas.

Keeping track of the mileage and preventing the detention of freight cars while on foreign roads are most difficult matters under the methods now in vogue, wherein the one using a car is expected to report such use to the owner. The *Railway Age* calls attention to the facts in connection with the Kansas City, Watkins & Gulf Railway and says: "Here are some of the facts shown: Car away from home 474 days and still missing; days accounted for, 317; held 73 days by one road, which paid \$4.08." Who calls this good railroading?

The proposed tunnel under the East River, for the use of the Long Island Railroad, which was the subject of a recent hearing before the city officers of New York and Brooklyn, is a much needed improvement in the transportation facilities between the two cities, and there seem to be no reasonable grounds for objections to the plan. The proposed tunnel would give the Long Island Railroad access directly into New York. The tunnel would be so deep as to avoid interference with the buildings and with any rapid transit tunnels that may be built, and we hope to be able to record favorable action in the matter at an early date.

The proposed lease of the West End Street Railway by the Boston Elevated Railway Company has been disapproved by the Railroad Commissioners of the State of Massachusetts, and the deal cannot go through in its present form, although it is likely that a new proposition will be made. The original proposition that was refused by the Commissioners provided for a lease for 99 years at a high rate of interest, and the refusal was based on the difficulty of guaranteeing this and at the same time providing for the reduction in rates that is expected to come in the ordinary course of events in the railroad business. A shorter term would probably receive more favorable action from the Commission.

The proposed ship canal from the Great Lakes to the sea was not favorably reported upon by Major Thomas W. Symons, who was appointed to investigate the subject under the River and Harbor Act of 1896. No military or commercial advantages at all commensurate with the cost were seen in the project. The types of ships on the lakes and the ocean were necessarily so different as to preclude the possibility of the same vessels being used in the traffic over such a waterway. The report was favorable to an enlargement of the facilities offered by the Erie Canal, and it was shown that the latter might be adapted to the use of large barges to good advantage. It would cost \$200,000,000 to construct a ship canal and \$2,000,000 per year to maintain it. The enlargement of the Erie Canal was recommended in the report.

As to the water-tube boiler, Commodore Melville, Chief of the Bureau of Steam Engineering, says in his annual report: "The Bureau feels that, with the experience now gained, the efficiency of the fleet will be best served by using water-tube boilers on future ships. As yet it can certainly not be said that any one of the numerous varieties of water-tube boilers is absolutely the best. Some of the ablest engineers in the world who, to cultivated talent add vast practical experience, have identified their names with particular forms of this type of boiler, and it is probable that, as experience accumulates, a form of boiler will be evolved embracing the best features of all of them . . . The Bureau does not advocate any one form of boiler to the exclusion of the rest, but believes that the best results will come from giving contractors freedom of choice of a form of water-tube boiler, subject to certain conditions of scantlings, general design and workmanship, which the Bureau is prepared to lay down."

The 80-foot yacht *Ellide*, built for E. B. Warren, Vice-President of the Barber Asphalt Company, from the plans of Charles D. Mosher, says *Engineering News*, has made the astonishing record of 37.89 miles per hour. She thus beats the *Turbinia's* record of 37.7 miles per hour. The *Ellide* is 80 feet long over all, 8 feet 4 inches beam and 3 feet 6 inches draft. She is of composite construction, with a double mahogany skin, fastened by Tobin bronze bolts, and steel frames and scantlings. Five steel bulkheads divide the hull into six water-tight compartments, and there are in addition a number of copper air tanks. The motive power is a quadruple expansion engine, with 9, 13, 18 and 24-inch cylinders and 10-inch stroke. The Mosher boiler is practically that used in the new torpedo launches and in the submarine torpedo boat now building at the Columbian Iron Works in Baltimore. The speed trial trip mentioned was made on the Hudson River over a mile course measured by the U. S. Coast Survey, and this distance was covered in 1.35 minutes.

The improvement on the Pittsburgh Division of the Baltimore & Ohio Railroad, 22 miles west of Cumberland, at Falls Cnt, has been completed and trains are running over it. Falls Cut is a cutting through a spur of the mountain and is about 60 feet in depth and has continually given trouble by rock sliding down on the track. Formerly it required bracing with heavy timber every few feet for its entire length, some 300 feet, and required constant care and watchfulness. It was, therefore, very expensive to keep up. In order to eliminate this cut it was necessary to build one mile of new roadway, which involved the construction of a double-track tunnel, 530 feet in length, and three bridges. By this change the road was straightened considerably, taking out some sharp curvature and introducing curves of longer radii. The improvement is on what is known as the eastern slope of the Alleghenies, and the grade is about 84 feet to the mile. The tunnel and bridges were constructed with the view of double tracking the entire Pittsburgh Division some time in the future.

The advantage of the track tank in passenger service is already appreciated by American lines, but the point seems to escape notice that in handling freight on a busy line there is much to be gained by this device, said Mr. George B. Leighton in a paper on "English Railroad Practice," read recently before the St. Louis Railway Club. Freight trains run from Crewe to London, a distance of upward of 150 miles, without stopping for water. The use of the track tank allows the use of smaller and lighter tenders. The standard tender of the London & North Western goods engine is only 1,800 gallons, but on this point English practice is not uniform. The Great Northern Railway, being part of the East Coast line to Scotland (one of the lines making the fast runs), does not use the track tank, and is thereby forced to carry a tender of large proportions and great weight. That is a point, it seems to me, that the American trunk lines do not appreciate; even some eastern lines that have track tanks in service for passenger work have not adopted them for freight. Why not use the track tanks in freight service as well as passenger, and thus avoid carrying this immense extra dead weight?

The ten United States naval dry docks have the following general dimensions :

	Length.	Breadth.	Depth of sill at high water.
Boston.....	396.5	69	25
Brooklyn.....	369.3	66	25
Brooklyn.....	509	85	25.5
Brooklyn.....	670	165.2	28
League Island.....	599	85	25.5
Norfolk.....	331.8	60	25
Norfolk.....	501	85	25.5
Port Royal.....	496	97	26.5
Port Orchard.....	659	92.7	30
Mare Island.....	513	79	27.5

In sailing to San Francisco, by way of Cape Horn, a United States war vessel might use one of the four dry docks at Rio Janeiro, the largest of which is the Sande Point dock, 520 feet long, 70 feet wide and 25 feet deep over the sill. At Montevideo the docks only provide for 17 foot draft; and at Talcahuano, Chili, is a stone dock 545 feet long, 80 feet wide and 28 feet deep. It is said that of the 748 dry docks in the world England owns about 60 per cent.; 249 of these being in England, 30 in Scotland and 18 in Ireland. Europe has 302 docks divided among 20 cities; Asia has 76, in 27 cities, and there are 22 docks in Oceanica and Australasia. The Liverpool docks, the largest in the world, cover 1,620 acres, with 36 miles of quay lines. The London docks cover 700 acres, and at Southampton is the largest single graving dock in the world—751 feet long, 88½ feet wide and 28½ feet deep on the sill.—*Engineering News.*

Personals.

Mr. W. W. Layman has resigned as Master Mechanic of the Ohio River Railroad.

Mr. John E. Stearns has resigned as General Manager of the Boise, Nampa & Owyhee, of Idaho.

Mr. B. R. Hanson, Master Mechanic of the Texas Midland, was succeeded Dec. 1 by U. R. Smithime.

Mr. F. P. Boatman, Master Mechanic of the Columbus, Sandusky & Hocking shops, has resigned.

Mr. H. T. Porter has been appointed Chief Engineer of the Pittsburgh, Bessemer & Lake Erie, with headquarters at Pittsburgh, Pa.

Mr. V. A. Riton, for several years Superintendent of the Cascade Division of the Great Northern, has taken a position with the Norfolk & Western.

Nathan Wright, formerly Master Mechanic of the Mahoning Division of the Erie, died at Cleveland, O. Dec. 8, of pneumonia. He was 67 years of age.

Mr. C. M. Stansbury has been appointed Master Mechanic of the Pecos Valley Railroad, with headquarters at Eddy, N. M., to succeed Mr. G. F. Miller.

Mr. Alberto Villasenor, Master Mechanic of the Ferro-Carril Santa Ana, has been appointed Master Mechanic of the Ferro-Carril Central, Salvador, C. A.

At a meeting of the directors of the Q & C Company, held in New York last week, Charles F. Quincy was elected President as well as Treasurer of the company.

Mr. W. B. Storey, Jr., Chief Engineer of the San Francisco & San Joaquin Valley, has been appointed General Superintendent with headquarters at San Francisco.

Mr. Ira C. Hubbell, heretofore Purchasing Agent of the Kansas City, Pittsburgh & Gulf, has been appointed Purchasing Agent of the Omaha, Kansas City & Eastern also.

Alexander Shields, Master Mechanic of the Chicago, Hammond & Western, has been appointed Master Mechanic of the Southern Indiana, with headquarters at Bedford, Ind.

Mr. J. A. Chisholm has been appointed Chief Engineer of the Mexico Cuernavaca & Pacific, with headquarters at the City of Mexico, in place of Mr. H. H. Filley, resigned.

Colonel William Crooks, heretofore Chief Engineer of the Minneapolis & St. Louis, at Minneapolis, has been appointed Chief Engineer of the Oregon Railroad & Navigation Co.

Mr. A. D. McCallum has been appointed Master Mechanic of the Cincinnati, Hamilton & Indianapolis division of the Cincinnati, Hamilton & Dayton Railway, at Hamilton, O.

Mr. J. A. L. Waddell, of Kansas City, Mo., has been appointed Consulting Engineer of the Boston Elevated R. R., and Mr. George A. Kimball, Boston, has been appointed Chief Engineer.

Mr. W. T. Godfrey, of the Oregon Short Line shops at Pocatello, Ida., has been appointed Master Mechanic of the Salt Lake & Ogden Railway, to succeed John Hurst, deceased. Mr. Godfrey's headquarters are at Salt Lake City, Utah.

Mr. J. A. Spoor, General Manager of the Wagner Palace Car Company, has been chosen President of the new company formed by a consolidation of the Union Stock Yards & Transit Company and the Chicago, Hammond & Western Railroad.

Mr. George F. Evans, General Manager of the Maine Central, was also chosen Vice-President of that road, at a meeting of the Directors, November 19. The position has been vacant since the retirement of Mr. Payson Tucker at the last annual meeting.

Mr. F. F. Fitzpatrick, for many years Chief Clerk to the General Manager of the Missouri Pacific Railroad, has resigned to accept the agency of the Charles Scott Spring Company, of Philadelphia, and has opened headquarters at Room 1402, Union Trust Building, St. Louis.

Mr. J. J. Conolly, heretofore Master Mechanic of the Duluth, South Shore & Atlantic, has been given the title of Superintendent of Motive Power and Machinery of that road. He has also been made Superintendent of Motive Power and Machinery of the Mineral Range and of the Hancock & Calumet Railroad Companies.

Mr. Harry W. Frost, who for a number of years has been identified with the business department of the *Railway Age*, has been appointed General Sales Agent for the Monarch Brake Beam Company of Detroit. His headquarters will be in Chicago. Mr. Frost has many friends and we join them in wishing him success in his new work. The Monarch Brake Beam Company is fortunate in securing such a popular and able representative.

Mr. W. S. Calhoun, whose services have recently been secured as Eastern Representative for the American Steel Foundry Company, is to be congratulated upon his new business relation and so is the company referred to. Men of Mr. Calhoun's ability are scarce and this concern could not have found a man for whom prominent railroad men have more respect. He was connected with the Chicago Tire and Spring Company for a number of years and is widely and favorably known. In his new position he will represent one of the best of the steel trucks, one that was designed by Mr. M. B. Schaffer, Master Car Builder of the Missouri Pacific Railway.

The Hon. Arctas Blood, of Manchester, N. H., died at his home in that city, November 24, aged 81. He was best known as the head of the Manchester Locomotive Works, incorporated in 1854 and with which he was identified until the time of his death. The Ameskeag Company was absorbed by the locomotive concern in 1872, and from that time fire-engine building became an important feature of the business. Mr. Blood's business career was very successful, and he held many positions in manufacturing enterprises. He had built up a considerable fortune and was known to have given liberally to many public and private charities. He was one of New Hampshire's best known citizens.

Dr. B. Kossmann, of Charlottenberg, has secured a patent covering a rust preventing paint composed of the peroxides of earths of the cerium group. The oxides in question, says the *Engineering and Mining Journal*, are incorporated with linseed oil varnish, to which is added as a drier a portion of linseed oil boiled with a mixture of boric acid and the peroxides. The resulting paint can be colored with graphite, lampblack, heavy spar, etc., and

is said to fulfill all the requirements exacted of such a composition, a sufficient oxygen content to insure the resinification of the linseed varnish and freedom from any metallic base capable of setting up an electrical action with iron, and so causing the formation of rust.

Books Received.

STRENGTH OF MATERIALS.—A Text Book for Manual Training Schools, by Mansfield Merriman, Professor of Civil Engineering in Lehigh University, 12mo, cloth, pp. 124. New York: John Wiley & Sons, 1897. Price \$1.

The author states in the preface that he has attempted to treat the subject of the strength of materials, beams, columns and shafts in a way that may be understood by those who have not the advantage of the calculus, and for this reason he used only the simplest of mathematical operations. The degree of mathematical preparation required is that now given in the higher grades of ordinary schools, such as high schools. The book was written specially for the students in the higher classes of manual training schools, and it was prepared with a view of rendering it easily comprehended by them, and at the same time cover all the essential principles and methods. At first glancing over the book we were inclined to take the view that such a task was too great for any writer, but on studying the work more closely we do not feel inclined to criticise it severely, because a student who carries out the intent of the work and who studies the subject by use of the numerical problems given cannot fail to get a good idea of the subject, even though he cannot bring the calculus to bear upon it. This may be considered as a case of Hamlet with Hamlet omitted, especially as regards the theory of beams, yet the book does not by any means give a mere smattering of the subject. It is a difficult thing to write such a book, and, considered strictly in the light of the object as outlined in the preface, it must be considered a success. An idea of the scope of the work may best be given by the following titles of the chapters: Elastic and ultimate strength, General properties, Moments for beams, Cantilever and simple beams, Columns or struts, The torsion of shafts, Elastic deformations, Resilience of materials and miscellaneous applications. A number of tables are given of elastic limits, tensile strengths, compressive strengths, weights of materials and constants.

SCRIBNER'S MAGAZINE FOR 1898.

The announcement by Messrs. Chas. Scribner's Sons, Publishers of *Scribner's Magazine*, shows that for the year 1898 an unusually valuable and interesting lot of articles has been arranged for, which will make this publication better this year than ever before, which is saying a great deal.

The story of the Revolution by Henry Cabot Lodge will be one of the leading features, of which the illustrations will form an important part. This is a large undertaking, the object of which is two-fold: to present a vivid picture of the Revolutionary War, reproducing the atmosphere and feeling of the time and avoiding the conventionally accepted text-book presentation. The other object is to show the historical significance of the effects of this war in a way which the author believes has not been appreciated. In speaking of the illustrations it should be mentioned that they will be prepared from sketches by well-known artists with a view of assisting in the effort to reproduce the atmosphere of the time. As a compliment to Senator Lodge's work, Capt. A. T. Mahan, U. S. N., will represent the influence of the American Navy in the Revolution, which will deal largely with the romantic side of the sea fighting of that war. Mr. Thomas Nelson Page will have his first long novel, "Red Rock," running through the numbers of the year, as the leading fiction serial. Mr. Walter A. Wyckoff continues his intensely interesting and very valuable articles, "The Workers," which during 1898 will have to do with the young author laborer's experiment in the West, where he had even more instructive experiences than those described in the series which appeared last year concerning his experiences in the East. A prominent feature of this series is to be a number of striking illustrations by Mr. W. R. Leigh, which will accompany each installment of the second part. Senator Hoar in his "Political Reminiscences" will record the observations made during his 45 years of public life. Robert Grant's search-light letters will be a popular feature again and those who have read the articles upon great businesses will look forward with interest to a continuation of these papers, to include "The Mine," "The Theater," etc. Among the other noteworthy articles will be three typical articles on "Bits of Europe in America," and "Life at

Girls' Colleges by Graduates." For short fiction, the work of Mr. Rudyard Kipling, Mr. Kenneth Grahame and Mr. George W. Cable may be looked forward to and the art features, including a number of studies of New York City by Mr. C. D. Gibson and Picturesque New York by Mr. Henry McCarter, promise to assist in making the volume attractive.

STATUTES OF ILLINOIS RELATING TO RAILROADS AND WAREHOUSES. Rules of Practice and Rules Governing Crossings and Interlocking Cases. Published by the Railroad and Warehouse Commission, Springfield, Illinois. Paper 8vo, pp. 105.

The State of Illinois has its regulations for the construction of interlocking apparatus in the form of rules which are well known. The book before us contains these rules and also those for public hearings in cases involving the protection of crossings by interlocking appliances which are brought before the commission for decision.

THE SCIENTIFIC PUBLISHING COMPANY announces the completion of arrangements for the publication of a new illustrated weekly technical journal, *The Mechanical Engineer*, edited by Mr. William H. Fowler, whose name is a guarantee of a valuable and interesting paper. The list of names of authors already secured includes a number well known upon both sides of the Atlantic. The proprietors are The Scientific Publishing Company, Hodson's Court, Manchester, England.

ANNUAL REPORT OF THE CHIEF OF THE BUREAU OF STEAM ENGINEERING, 1897. Washington: Government Printing Office.

This report gives a statement of the appropriations for steam machinery, the general operations of the bureau, expenditures of money at the various navy yards and stations and an extended table showing the condition of each of the vessels of the navy. Valuable comments are offered on the following subjects: Water tube boilers, liquid fuel, the building of machinery and vessels in classes, the lighting of machinery compartments, machinery of ships in reserve, machinery plant for repair ships, steel inspection, personnel, enlisted men in the engineer department, and trials of new vessels. The report presents a favorable opinion of water tube boilers for war ships, but which is, withal, a satisfactorily conservative view. The lack of facilities for the proper training of men in the engineer's department is clearly shown, and the advantages of a training ship for these men are brought out. The careful and considerate study of the progress of steam engineering for war vessels which is reflected in this report, together with the evident watchfulness to permit no opportunity of improving the service to escape the bureau, gives assurance of the wide-awake condition of the department.

PROCEEDINGS OF THE FIFTH ANNUAL CONVENTION OF THE NATIONAL RAILROAD MASTER BLACKSMITHS' ASSOCIATION, 1897.

The principal subjects treated are as follows: The Master Blacksmith and his Duties, The Railroad Scrap Pile, Making and Repairing Springs, Locomotive Running and Valve Gear, Smith's Furnaces, Axle Making, Steel Axles, Machine Forgings, Case Hardening, Tool Steel, Track Tools, Locomotive Frames. The report is edited by Mr. A. L. Woodworth, C., H. & D. R. R., Lima, O., Chairman of the Executive Committee.

PROCEEDINGS OF THE 28TH ANNUAL CONVENTION OF THE MASTER CAR AND LOCOMOTIVE PAINTERS' ASSOCIATION OF THE UNITED STATES AND CANADA, held at Old Point Comfort, Va., 1897. Published for the Association by the *Railroad Car Journal*; New York. 1897.

This report gives the names of the officers and members of the association, the names of the committees and the proceedings of the recent convention. The volume is well printed and is bound in cloth (standard size). The work of the association is too well understood to require explanation to our readers. It covers the application of the art of painting to railroad rolling stock.

ANNUAL REPORT OF THE CHIEF OF THE BUREAU OF CONSTRUCTION AND REPAIR TO THE SECRETARY OF THE NAVY, for the fiscal year ending June 30, 1897. Washington: Government Printing Office, 1897.

REPORT OF THE COMMISSIONER FOR RAILWAYS, Queensland, Australia, for the year ending June 30, 1897. Brisbane, 1897.

BULLETIN OF THE DEPARTMENT OF LABOR, No. 13, November, 1897. Edited by Carroll D. Wright, Commissioner, Washington. Government Printing Office, 1897.

LE MÉCANISME DU DIT FLUVIAL, par V. Lokhtine, Ingénieur Voies de Communication, of Kazan. Translated into French by

A. M. Danzig, Ingenieur des Ponts et Chaussées, and edited by Du Bureau Technique International a St. Petersburg. St. Petersburg, 1897.

REPORT OF THE SURGEON GENERAL U. S. NAVY, Chief of the Bureau of Medicine and Surgery, to the Secretary of the Navy. Washington : Government Printing Office, 1897.

MEMORIAL DE INGENIEROS DED EJERCITO. Fifty-second year, Vol. XIV., No. XI., November, 1897. Madrid, 1897.

SIXTH REPORT OF THE BUREAU OF MINES OF ONTARIO, 1896. Printed by order of the Legislative Assembly of Ontario. Toronto, 1897.

IS THE INVENTIVE FACULTY A MYTH? A pamphlet reprinted from *Cassier's Magazine*. 8 pp.

PROCEEDINGS OF THE UNITED STATES NAVAL INSTITUTE, Vol. XXIII. Edited by H. G. Dressel. Annapolis, Md., 1897.

JOURNAL OF THE UNITED STATES ARTILLERY. September and October, 1897. Published by authority of the staff of the Artillery School. Artillery School Press, Fort Monroe, Va.

NINTH SPECIAL REPORT OF THE COMMISSIONER OF LABOR. The Italians in Chicago, a Social and Economic Study. Prepared under the direction of Carroll D. Wright, Commissioner of Labor. Government Printing Office, Washington, 1897. 403 pp.

This report deals with the social and economic condition of the Italians in Chicago, and in it will be found valuable material for use in considering the question of immigration.

HENRY CABOT LODGE, Senator from Massachusetts, who is writing "The Story of the Revolution," for *Scribner's*, begins with a picture of the social conditions in Philadelphia in 1774, showing it to have been the most civilized city in the country at that period. Mr. Lodge is particularly strong in his characterizations of the great men of the time—Adams, Patrick Henry, Franklin, Washington.

Trade Catalogues.

An exceedingly attractive celluloid easel desk calendar for 1893 has been received from the Magnolia Metal Company. The calendar for each month is printed on a card held in a pocket and above this is printed matter in two colors devoted to the interests of the company. It is stated on the calendar that Magnolia Metal is in use by 10 leading governments.

THE SARGENT COMPANY has sent out a calendar for December which reached us too late for mention in our December issue. Upon it are shown a dozen pictures giving an excellent idea of the character and scope of the business of this company. Among the pictures relating to railroad work are several of the new "Diamond S" brakshoe, and of steel wheel centers, such as are being furnished for Western railroads. The large steel gears recently cast are included in the illustrations of general machinery castings.

STEAM BOILERS, constructed by Yates & Thom, Canal Foundry, Blackburn, England. This is an interesting catalogue, which has for its primary object the illustration and description of the product of the works of Messrs. Yates & Thom, and for a secondary object it was intended to give engineers a lot of valuable information in regard to the present state of the art of English boiler construction and design. It is successful in both of these directions and is not unlike a number of the catalogues of the foremost of the American steam boiler manufacturers, except that it is more comprehensive. In addition to the illustrations of the boilers and appliances made by the company referred to there are a number of articles on the details of boiler construction with detail drawings of parts. The ordinary problems in boiler design are treated, including such subjects as boiler joints, furnaces, piping, steam separators, feed water heaters, the construction of chimneys and the prevention of smoke. The catalogue is from the pen of Mr. William H. Fowler, who is to be the editor of the new English paper, *Mechanical Engineer*. The price of the catalogue is five shillings. It is valuable as a book upon boiler practice and more money is frequently paid for less valuable treatises on the subject.

A Business Need Supplied.

There are few practical men of business who do not recognize the benefit of advertising in hunting new and holding old trade,

That many fail to show a proper appreciation of the fact by keeping alive an up-to-date and representative line of advertising is largely because to do so requires more time and attention than is available where those who must be entrusted with the work have already more than enough to occupy them. The need, too, of a master mind is an essential that is more than likely wanting in most instances. Not all of those who find themselves thus situated are aware that there is in existence in New York City a concern whose business is to supply to manufacturers the time and attention necessary for the efficient and profitable management of the advertising end of a business.

The Manufacturers' Advertising Bureau, 126 Liberty street, New York, supplies a business need. With the testimony of many of the largest and most prominent manufacturers at hand to back up the statement, we can say it is a thoroughly advantageous business connection for the progressive but pressed-for-time advertiser of to-day. The firm that places its newspaper work and advertising in the charge of this Bureau will be relieved of the many vexatious time-taking but nevertheless necessary details that combine to make advertising pay, and will at the same time have the benefit of 20 years' experience in trade journal advertising.

Mr. Benj. R. Western, the proprietor of the Bureau, is a thorough newspaper man of extensive experience in trade journal advertising. He has associated with him in the conduct of his business a corps of able assistants, qualified by experience to further in every way the interests of clients of the Bureau. The methods of the concern are such as the times demand. Their clients are well-served, and the number, we are pleased to note, is increasing every year.

A little book bearing the title "Advertising for Profit" is issued by the Manufacturers' Advertising Bureau, and tells in a brief busy man's way how Mr. Western and his associates work. Copies, we are informed, can be obtained gratis upon application accompanied by a business card.

A New Brazing Crucible.

A new or liquid process of brazing is threatening the old-time flame method. Several years ago it was demonstrated by a company formed for that purpose that a specially treated joint, plunged into molten spelter, would not only braze in a very few seconds, but would, in addition, come out almost entirely free from scale, a brisk cleansing by a metal brush being about all the after treatment required. The process was a secret one, the most important point being the anti-flux, which was a preparation painted over the parts to which it was desired the spelter should not adhere.

Briefly described, liquid brazing consists merely in reducing

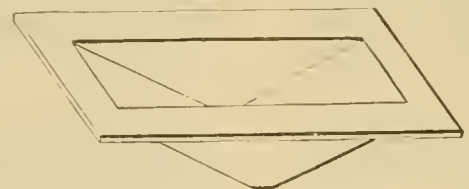

A New Brazing Crucible.

the spelter to a molten form in a suitably shaped crucible at a high temperature, and then immersing the joint to be brazed in the liquid mass. The surfaces to be brazed are painted with a flux, and the adjacent parts with an anti-flux. A few months ago nothing definite was known regarding the best preparation for an anti-flux, each experimenter endeavoring to find out the best for himself, but the Joseph Dixon Crucible Company, Jersey City, N. J., placed on the market an anti-flux, known as Brazing Graphite, and repeated tests have demonstrated its value.

On account of the high degree of heat required, even the best of wrought-iron vessels possessed but short life under this treat-

ment. The Dixon Company, on account of its well-known reputation as crucible manufacturers, were therefore called upon to furnish some vessel that would successfully withstand the intense furnace heat. They have furnished several styles of graphite bowls, oblong crucibles, and other special styles, but have now manufactured a crucible specially adapted for this work. An outline sketch is shown above. It is 24 by 6 inches inside, the bottom forming an angle, being 10 inches deep in the middle. It has a 3-inch flange to support it in the furnace, and can be used in either coke, coal, gas or oil furnace. Further particulars will be furnished by the Joseph Dixon Crucible Company, Jersey City, N. J.

The Peerless Hose Nipple Cap.

The little device which is shown in the accompanying illustrations is one of the simplest improvements that have been brought out in connection with air-brake apparatus, but it is a very effective one and merits attention because its use will greatly prolong the life of air-brake hose. The object of the invention was to provide means for reducing the destructive effect of the cast iron

from 45 to 55 per cent. of the hose that is secured to the castings in the usual way.

Incidentally the cap furnishes a good packing at the joint, but it is the cushioning action for which the claims are made. The harsh edge of the iron is prevented from acting on the hose, and it cannot injure the cap. The cap does not in any way interfere with the action of the air-brake as has been demonstrated by the Westinghouse Air Brake Company, and the application of the caps is easy. The cap is coated with rubber cement, and the nipple or coupling is put on in the usual manner, as the resistance added by the presence of the cap is very slight. The cost is very low, and one of the best features of the cap is that it goes on any make of hose, no matter whether it is "cheap" or "good" hose. The Peerless Rubber Manufacturing Company, 16 Warren street, N. Y., has the sole manufacturing rights for the United States and patents have been taken out in this and other countries.

The Garrison's Accident.

The conclusions of the State Railroad Commission regarding the cause of the New York Central wreck near Garrison's, on Sun-



The Peerless Hose Nipple Cap—By the Peerless Rubber Manufacturing Company.

nipples and couplings upon the hose at the ends of the castings. The engravings show the cap to consist of a ring of soft rubber folded internally at the end and cemented over a thin and narrow ring of brass, the office of the ring being to prevent the thin rubber lip of the cap from doubling up when put on the nipple or coupling. The cap, being of soft rubber, presents a yielding surface to the hose at the edge of the casting and prevents the cutting and wearing of the hose at that point which has been found to greatly reduce the life of the hose.

Mr. C. H. Dale, President of the Peerless Rubber Manufactur-

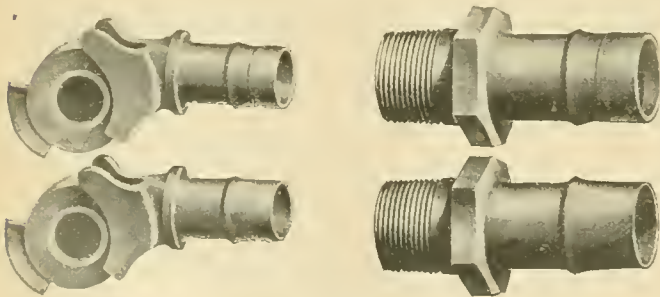

Westinghouse Couplings and Nipples, Showing Method of Application of Cap.

ing Company, is the inventor, and in investigating the cause of the failure of hose he ascertained that a large proportion, which he places at 90 per cent. of all the hose used, fails at the edge of the iron nipple connecting the hose to the train pipe. This is due to the bending of the hose against the iron in swinging. He has been working on the problem for several years and has only recently perfected the device to such a point that it is applicable to any hose and any nipple, as neither of these could be changed. Severe tests have been made by Mr. Dale, which show that the hose when protected with this cap may be expected to outwear

day morning, Oct. 24, whereby 18 passengers and three employees lost their lives, have been made public. The board, after an exhaustive investigation, which was conducted with the aid of expert engineers, is unable to determine the primal cause of the accident. In this respect each of the members of the Railroad Commission, Col. Ashley W. Cole, Frank M. Baker and Col. George W. Dunn, agree. The report says:

"Our final conclusions are that this train was wrecked either by derailment, which destroyed the embankment, or that the embankment gave way and threw the train into the river. Therefore the board feels it to be its public duty to recommend in urgent terms and to require that all railroads in this State whose roadbeds, or parts of roadbeds, are carried on embankments lying alongside of and washed by watercourses, shall give careful inspection to and provide constant and efficient maintenance for such embankments. Such care and supervision will do much to lesson, if not to abate wholly, one source of danger.

"This recommendation is not intended by the board, nor should it be regarded by the public, as expressing in any sense whatever belief that the accident which has been the subject of this inquiry and report was due, even secondarily, to a defective embankment. If this train was derailed it is doubtful whether any embankment, however rigid and sound, would have withstood such a shock if exerted directly against it. An expert engineer who testified before the board declared that the weight of this train, being all told 540 tons, moving at a speed of 40 miles an hour, its dynamic force or energy, if directed against a certain point, would be equal to 65,000,000 or 70,000,000 of foot pounds, or sufficient to have lifted the entire train 67 $\frac{1}{2}$ feet in the air. It is obvious that practically nothing but a mountain could resist such an impact."

Fads and Their Cost.

The members of the New York Railroad Club enjoyed a racy paper by Mr. R. P. C. Sanderson at the meeting held Dec. 16, and while the discussion brought out differences of opinion in regard to some of the suggestions it was clear that they nearly all struck home. We present the following extracts from the paper:

The object of this paper is to show that it is worth while to be

mean and stingy where the efficiency is not impaired thereby, and at the same time to give an idea of how the cents multiply into dollars. It is not for an instant supposed that every one of the savings later referred to can be effected by all of us, nor is there thought to be anything original about any of the items mentioned; they are simply selected for illustration. We can all doubtless find other items than these, some of us more and some of us less, according to the numerical value of the equipment, and the amount of attention that has already been given to the pennies, and to the amount of free hand we have in our own bailiwicks.

Owing to the continual loss of nuts off archbar and box bolts, it was proposed to use only one nut on these bolts with a split key under the nut. The cast washers commenced breaking by the hundreds, the pieces fell out, the archbars bent and broke. The remedy at once proposed was to use malleable or wrought washers. All things considered, wrought washers were best, and thousands of them were stamped out of scrap under the steam hammer. Most careful investigation showed that the reason why the cast washers broke was because they were not flat, but had fins and small nubbins on their sides, and also because of the springing of the archbars—by simply turning them upside down so that the rounded sides come against the archbar, the cast washer stands without breaking and saves 92 cents per car.

For the 1,900,000 freight cars in the United States and Canada this would equal \$1,172,000.

A cylindrical 16-inch stack with a modest curved cast-iron top and not too ornate cast base, with Russia iron casing and a choke inside, costs, complete, about \$15.51. A cast smokestack complete, weighing 520 pounds, can be produced for from \$3 to \$4, showing a maximum saving per engine of about \$11.51. For the 35,800 locomotives in the United States and Canada this would mean \$412,058.

When the railroads of America began to realize that the old familiar diamond stacks must go there was choice of two prototypes of front ends of engines, one known as the Smith, the other as the Hill. The former had no extension and cleaned itself; the latter had an extension and was expected to retain the cinders. It became "the thing," and has cost the railroads millions of dollars for cleaning out cinders at terminals and between terminals, as well as for loading, transshipping and disposing of the cinders. All this could have been saved without any offsetting disadvantages or costs if the Smith front, which cleaned itself, had become the thing instead of the Hill. It is estimated that 25 cents per 100 engine miles would approximate the total cost of cleaning the cinders out of the fronts, loading them, hauling them away and dumping them, which would represent over \$2,500,000 per annum. This does not include the additional first cost of the extension front, which would come to about \$14 per engine, or \$501,200—five per cent. interest would equal, per annum, \$25,060.

Combustion chambers have their uses and merits in stationary and marine boilers of certain kinds and sizes, but to shorten the flues of a locomotive boiler from 6 to 14 inches, to introduce separate flue and flanged throat sheets, with the concomitant endless troubles, sacrificing at the same time 100 or so feet of valuable heating surface, all to get a 6 or 14 inch space in the front of the firebox for "combustion chamber" purposes seems like carrying a fad a little too far.

It has been a custom from the first to use semi-elliptic springs for carrying the weights of our locomotives on the driving boxes. How much more ease of motion is there in a 30-inch semi-elliptic having 24 to 26 leaves $\frac{3}{8}$ inch thick and $3\frac{1}{2}$ inches wide, and costing close on \$10, as compared with a pair of coil springs of the same capacity costing, perhaps, 70 cents? The extra cost would represent nearly \$2,502,500, the interest on which at five per cent. per annum would be \$125,125. A similar argument could be used with regard to tender truck springs, where the net saving would mean \$1,656,824.

There is no longer any good purpose in putting headlights of the size of a small Saratoga trunk on the front of engines. All that is really needed is a front signal lamp of a distinctive character. There is a positive danger in using a very brilliant and powerful headlight, such as some of our electric friends are interested in, for the reflected glare off the surface of the switch lamp lens is often so great that it entirely overpowers the light coming from the lamp, and will show apparently white light to the engineman while the signal may be standing at red or green. For safety a runner must therefore look for the position of a target or semaphore and not trust to the lights at night. According to the nature of the country through which a railroad runs, a saving of from \$6.50 to \$10.50 per engine can be effected by using a 16-inch or a 12-inch headlight instead of a 23-inch headlight.

Can anyone defend the practice, now becoming gradually obsolete, of fancy painting and gilding of locomotives? A modest legend of 15 letters, giving the name of the road on each side, would cost for gold leaf and labor \$4.60; in chrome yellow paint the labor and material would cost \$1.50.

The painting, lining, striping and varnishing of passenger trucks will cost \$7.40 per car. Two good coats of paint applied without decoration or varnishing cost \$2.30 per car.

The inside rubbing down of the varnish to an eggshell gloss costs for labor \$11.40 per car. A light rubbing down with one fifth benzine and four-fifths raw oil slightly deadens the brush gloss of the new varnish, producing a very fair representation of the eggshell gloss, and can be done for \$1.70 per car. While if the brush finish were left undisturbed, none but trained eyes would notice the difference, and it is safe to affirm that of those who did notice it not one would change his route on this account.

The statistics of our railroad accidents certainly do not show that good chilled wheels are unsafe, or that steel-tired wheels are any safer for the present average passenger car-wheel loads, and there does not seem to be any good reason why railroads should charge their equipment accounts with from \$280 to \$418 per car for steel-tired wheels, and burden their maintenance of car accounts with the cost of tire turnings and renewals.

The pressed steel trucks were a big improvement over some

freight trucks, but that does not necessarily imply that they are better than all archbar trucks, and they certainly are an increased source of expense when renewing wheels; besides, when bent up in a mishap, are practically unrepairable at the ordinary railroad shop, and can only be scrapped, unless the shops are provided with formers and presses to reset them after the parts are cut apart. Now, a good all-steel diamond truck with double 8-inch eye-beam blocked bolster, steel spring channel, steel brakebeams with inside-hung brakes, malleable center plate and side bearings, $1\frac{1}{2} \times 8$ inch M. C. B. axles and 600 pound wheels, which cost just as little for running repairs as the pressed steel truck, and cost a great deal less in case of accident repairs, can be built for \$71.59 per truck, including all material, all shop labor, uncharged time and supervision. Such being the case, we ought to stop to think several times before increasing the cost of our cars about \$70 each for pressed steel trucks; this amount would very nearly pay for an outfit of air-brakes and couplers for the car and help the railroad company to comply with the terms of the Railway Safety Appliance Act.

It has been a fashion in some parts of the country to stencil the freight cars with 30 to 36 inch letters and figures, as if the conductors and yardmen were in the habit of standing off a quarter of a mile when taking numbers. If those who stencil cars in this way had to run along a train of 35 cars on a dark night between the tracks in the yard, taking initials and numbers, they would very soon resort to the use of small letters and figures grouped close together where the light of a hand lantern would cover them all at once, and so that the eye can at short range take them in at one glance at daylight or dark, instead of having to run up and down all the way along a 34-foot car to have to read four or five initials and four or five numbers. The large stenciling for about five letters and five figures repeated on both sides of the car costs for white lead and labor, 76 cents. The same number of 6 or 7 inch letters and figures grouped together would cost 34 cents; difference in favor of small stenciling per car, 42 cents. If this could be saved for all the 1,900,000 freight cars in the United States and Canada, it would mean \$499,800.

Now, if we assume that freight cars require restenciling once every four or five years, this would represent an annual outlay of \$99,960 spent on the fad of large lettering, without counting interest.

The little red caboose behind the train is commonly painted with vermilion, or a cheap imitation thereof, because it is to be considered as a danger signal, and bright red is the danger color. To be consistent we should paint the front ends of our locomotives a very bright scarlet, and the ends of all passenger, Pullman and freight cars the same color. Our bright red caboose is just as brown as a common freight car after two or three months running, but remains just as dangerous to run into in spite of having lost its brilliancy. The two months that the red imitation vermilion stays at danger color costs us \$6.40 per caboose, instead of \$1.65 for brown paint, the difference being \$5.75 spent on a bright red fad.

In presenting this paper the writer, in conclusion, will ask the members to consider that it is the result of hard times and not to think the spirit of it is simply iconoclastic.

Fast Runs on the Union Pacific.

Some remarkably fast runs have been made upon the Union Pacific Railway recently and they appear to be rather a common occurrence. On November 23 the Fast Mail made a run concerning which Mr. J. H. McConnell writes us as follows:

The train was delayed six hours at Medicine Bow, Wyo., on account of a bridge burning out. On arrival at Cheyenne, Wyo., it was decided to run the mail in order to reach Council Bluffs, Ia., in time to avoid paying the fine which is imposed by the Postal Department, according to the terms of the contract under which the mail is carried, when connections are not made with Eastern lines. There was no special preparation made for this run; the engines were our regular passenger engines and were selected in their turn out. The train left Cheyenne 5 hours and 28 minutes late and arrived at Council Bluffs 40 minutes late, having made up 4 hours and 48 minutes. The distance run is 519 miles and the time occupied on the run was 557 minutes, which includes all stops and slow downs.

Engine 1813, with two mail cars, left Cheyenne at 7:23 a. m., mountain time, arrived at Sidney 9:15 a. m.; 102 miles in 107 minutes.

Left Sidney at 9:21 a. m., engine 841, arrived at North Platte 11:19 a. m.; 123 miles in 118 minutes, stopping two minutes at Julesburg, Colo., for mail from Denver.

Left North Platte 12:23 p. m. (central time), engine 816, arrived at Grand Island 2:57 p. m.; 137.5 miles in 157 minutes. Delayed at Lexington $3\frac{1}{2}$ minutes taking water and changing engineers; Engineer White making the run from Lexington to Grand Island, $7\frac{1}{2}$ miles, in $80\frac{1}{2}$ minutes, making one stop at Kearney.

From Grand Island to Council Bluffs, 156.2 miles, engine 890 left Grand Island at 3:02 p. m., arrived at Columbus at 3:55 p. m., 63 miles in 53 minutes; delayed 5 minutes fixing tank-hose and taking water. Left Columbus at 4 p. m., arrived at Fremont 4:42, 45 miles in 42 minutes; left Fremont, 4:44, passed Valley, 11 miles, at 4:55, passed Gilmore, $36\frac{1}{2}$ miles, at 5:28 $\frac{1}{2}$, passed Omaha 5:40, arrived at Council Bluffs 5:45 p. m., 15 minutes ahead of the leaving of eastern mail from Council Bluffs.

The 100 miles between Grand Island and Ames were made in 88 minutes, including the stop of 5 minutes at Columbus. There was delay of 3 minutes at Millard, 4 at Portal, and slow time from Gilmore to South Omaha, and between South Omaha and Council Bluffs.

This is a noteworthy performance when it is considered that the decision to make a fast run was not premeditated. It is a fact that the grades favored the speed. There is a difference of eleva-

tion of 7,030 feet between the terminals of this run, Council Bluffs being the lower. The speed in this case averaged 50.7 miles per hour from the start to the finish.

The engines referred to belonged to three classes, of which the chief dimensions are as follows:

DIMENSIONS OF LOCOMOTIVES.

	Engine Numbers.		
	1813	841 and 816	890
Type	10-wheel	8-wheel	8-wheel
Cylinders, diameter.....in.	20	18	19
stroke.....in.	24	26	24
Steam ports.....in. X in.	17 X 1½	16 X 1¼	17 X 1½
Exhaust.....in. X in.	17 X 3	16 X 2½	17 X 3
Travel of valve.....in.	5¼	5¼	5¼
Lap of valve.....in.	¾	¾	¾
Lead in full gear.....in.	1/16	1/16	1/16
Diam. driving-wheels.....in.	69	69	69
Driving-axle journals.....in.	8 X 11	8 X 11¼	8 X 11¼
Truck axle journals.....in.	5½ X 10	5½ X 10	5½ X 10
Firebox, length inside.....in.	108	72½	96
Firebox, width inside.....in.	32¾	33¾	31¼
Heating surface.....sq. ft.	1,958.50	1,317.6	1,688.9
Grate area.....sq. ft.	24.56	16.71	22.8
Weight of engine.....lbs.	131,200	107,000	119,600
Weight on drivers.....lbs.	103,400	69,300	81,025
Weight of tender empty.....lbs.	45,900	45,900	45,900
Capacity coal.....lbs.	28,000	28,000	28,000
water.....gals.	4,000	4,000	4,000

TRAIN WEIGHTS

Cheyenne to Sidney.

	Pounds.
Engine 1813 and tender, with coal and water.....	238,433
Train, two mail cars, 60 feet, with load.....	192,000

Cheyenne to Sidney, total engine and train.....330,433

Sidney to North Platte.

	Pounds.
Engine 841 and tender, with coal and water.....	214,233
Train.....	192,000

Sidney to North Platte, total engine and train.....406,233

North Platte to Grand Island.

	Pounds.
Engine 816 and tender, with coal and water.....	211,033
Train.....	192,000

North Platte to Grand Island, total engine and train.....403,033

Grand Island to Council Bluffs.

	Pounds.
Engine 890 and tender, with coal and water.....	226,833
Train.....	192,000

Grand Island to Council Bluffs, total engine and train.....418,833

We stated that several fast runs had been made. On Dec. 4 the fast mail ran from Sidney to Grand Island, 261 miles, in 238 minutes, or at the rate of 65.6 miles an hour. From Kearney to Grand Island, 42 miles, the time was 36 minutes, or 70 miles an hour. On the next day a special theatrical train ran from North Platte to Council Bluffs, 294 miles, in 286 minutes. This train was delayed at the crossing at Portal, which, with the regular stops, made the rate of speed while running 61.1 miles an hour.

On Dec. 10 the fast mail ran from Cheyenne to North Platte, 225 miles, in 214 minutes, at the rate of 63.1 miles an hour. On the first part of the trip, Cheyenne to Sidney, 102 miles, the time was 97 minutes; the second part, from Sidney to North Platte, 123 miles, consumed 117 minutes.

The Player Metallic Truck.

Among the metallic car and tender trucks to attract attention recently are the designs by Mr. John Player, Superintendent of Machinery of the Atchison, Topeka & Santa Fe Railway and made by Messrs. Shickle, Harrison & Howard of St. Louis. We show the construction of the freight truck in the accompanying engravings. These trucks are very much alike, the chief differences being due to the fact that coil springs are used on the freight truck and elliptic springs on the tender truck. The bolster and transoms are of cast steel and the side frames are of the diamond type.

The weight of the transom is 550 pounds, and that of the bolster is 350 pounds, including the side bearings. It will be seen from the drawing that the springs may be removed very easily from the ends of the bolsters upon raising the bolsters by means of jacks. The castings are of open-hearth steel, and as there can

be but little wear upon the parts, they should last a long time in service. Fig. 1. shows the construction of the freight truck.

Through the courtesy of Mr. Player and also of Mr. Willis C. Squire, Mechanical Engineer in the Motive Power Department of the road, we have received a copy of the results of the tests of the bolsters by Mr. Squire, and they are of special interest.

In the tests it was desired to subject the two members of the truck, the frame and the bolster, to the same strains as would be encountered in service; that is, to arrange the parts so that the load would be carried on the points or surfaces that were designed to carry them.

The first tests were made on the tender transom and bolster. The arrangement of the parts for the tests is shown in Fig. 2. The bolster was placed on the center plate and resting on the upper head of the testing machine. The spring pockets were filled by wrought-iron filler blocks and upon these the transom was placed. This arrangement brought the parts into the same relative positions as in practice, except that the whole com-

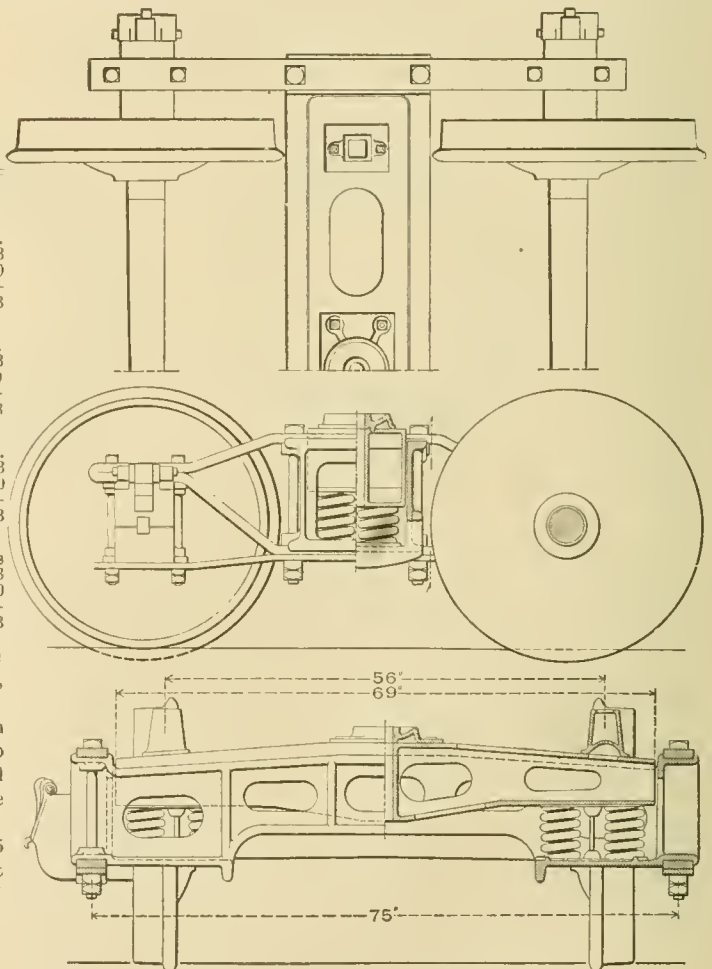

Fig. 1.—Construction of the Player Truck.

ination was inverted and carried on the center plates. Yokes were hung in the arch bar guides and the load was applied through them by the movable head of the machine. The capacity of the machine is 200,000 pounds. The tests were elaborate and the report gives evidence of very careful work both in the planning and in the execution. It is, in fact, the most comprehensive test of this kind that has come to our attention. We shall be able to present only a brief summary of the results in the space at command.

In the tests an initial load of 10,000 pounds was used in order to bring all of the parts to a solid bearing. The readings of the deflections were taken with micrometer and vernier calipers, using electric contacts to ring a bell for the purpose of avoiding the possibility of error due to the springing of parts in taking the measurements. Fig. 2 shows the methods of measuring elonga-

tions. The deflections were all plotted in curves, and these indicate that the elastic limit of the transom and bolster when taken together is about 145,000 pounds. This would give a factor of safety of more than two before the elastic limit is reached under a load of 50 tons on both trucks. The results show the elongation of the frame for a load of 155,000 pounds to be 0.082 of an inch in the bottom and 0.007 in the top of the frame, and in subsequent tests it was found that there was no permanent set in this respect even under loads of the full capacity of the machine, 200,000 pounds.

Tests of the tender bolster alone showed the elastic limit to be about 155,000 pounds and at a load of 150,000 pounds the deflection was but one-quarter of an inch. Under a load of 180,000 pounds the deflection of the bolster was 0.412 inch. The top

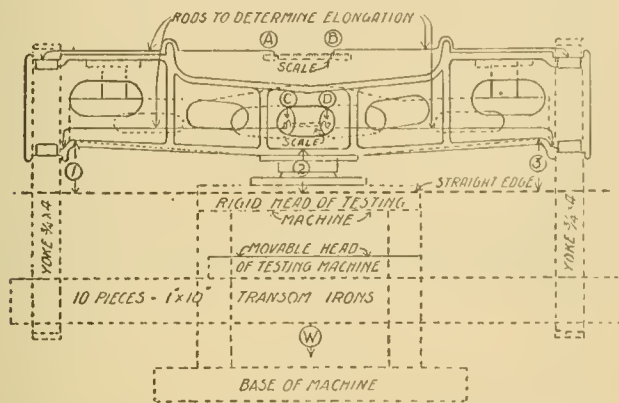

FIG. 2.—The Method of Testing Tender Bolster and Transom.

view of Fig. 3 shows the deformation of the bolster, the dotted lines showing the outline before the loading.

The freight car truck frame, being identical in form with the other frame, it was not tested. The freight car bolster was tested and it was thought desirable to change the locations of some of the openings in order to strengthen it, though it was not considered really necessary to do so. The outline of this bolster before and after loading is shown in the lower view of Fig. 3. The maximum total load on the freight bolster was 166,200 pounds and the deflection was 0.939 inch. The tests as a whole prove

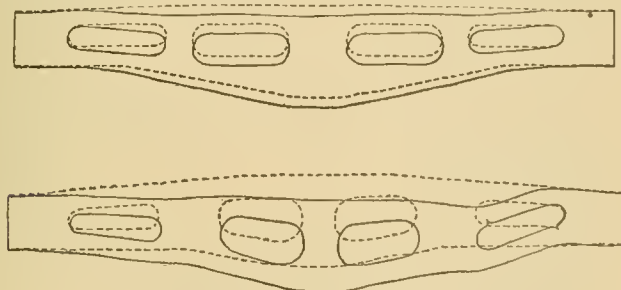

FIG. 3.—Distortion of the Bolsters in Tests.

the construction to be a very strong one, one of the best features being the fact that no two parts of the bolster gave way at the same time and the final yielding was so gradual as not to cause uneasiness in regard to accidents on the road.

The metal of which the bolsters were made showed a tensile strength of 66,800 pounds per square inch. Bending tests also gave satisfactory results and developed the fact that the material might be expected to fail, if at all, after the manner of wrought iron.

Comment upon these figures is entirely unnecessary. The design and the material appear to be equally good. These bolsters and the transoms show an excellent distribution of the metal and the combination is a strong one. It is regretted that data are not available for comparisons with other types upon this basis. It should be stated that the length of the bolsters, both for cars

and tenders, is 68½ inches, while the distance between side bearings on the tender bolster is 53 inches and on the car truck bolster it is 56 inches.

The B. & O. Service to the Klondike.

The railroads expect a rush of travel to the Klondike in the spring. It is estimated that a great many people will attempt to reach the goldfields as soon as the winter is over, and with a desire to turn a nimble penny at every opportunity trunk lines are beginning to prepare for the expected rush.

One of the first in the field is the Baltimore & Ohio Railroad which will on Tuesday, Dec. 21, begin the running of the through tourist car from New York City to San Francisco without change by way of Philadelphia, Washington, Parkersburgh and Cincinnati, reaching St. Louis Wednesday evening, Texarkana Thursday afternoon, El Paso, Texas, Friday evening, and San Francisco Sunday morning.

This service is in addition to the one provided by the Baltimore & Ohio Railroad from Pittsburgh by way of Cincinnati and the Illinois Central to New Orleans and the Southern Pacific through to the coast, the Pittsburgh car leaving every Wednesday. The New York car on its return leaves San Francisco Monday evening and the Pittsburgh car leaves on Thursday.

The "Composite" and its Field.

The "Composite" or steam motor car of the New England Railroad was illustrated and described in our November issue of last year (page 362), and on page 382 of that issue, under the caption, "The New Problem in Transportation," we outlined the reasons for its design and expressed the opinion that its field was large and important. Mr. C. Peter Clark, General Manager of the New England Railroad, read a paper upon this subject at the meeting of the New England Railroad Club Dec. 14, from which we reproduce the following paragraphs:

Even in New England, with its dense population, the public demand for increased service has for the past 10 years resulted in such additional passenger train mileage as equaled, and in many cases outstripped, the increase in earnings. In other words, the average number of passengers using each train is no more than 10 years ago, despite the natural increase in population. With 16.6 per cent. of the steam railroad mileage of this country now or recently in the hands of receivers, an increasing demand for more expensive service, and with competition from trolley lines furnished with a right of way at the public expense taking the business of the steam railroads *only* where it is profitable and leaving the existing carriers to serve the public where the business must be done at a loss, the present situation certainly seems to justify careful examination.

During the year ending June 30, 1897, the number of passengers carried in and out of Boston shows an actual decrease over the previous period of 12 months, which amounts to a loss of nearly 4,000,000 passengers, or seven per cent., while the number of people transported by the West End Street Railway System, with its numerous suburban lines, shows an increase of 5,500,000 passengers. The past year has seen an application of electricity to the steam track of the New England Railroad between Hartford and New Britain—about 10 miles. The service between the two places was practically doubled, but arranged at a uniform interval of 30 minutes. No baggage was taken and the fare established at 10 cents, a reduction of substantially 45 per cent. The business increased over threefold.

There are many places where similar increases in business might be expected, but even that increase of business in most localities would not warrant the necessary capital outlay for electrical equipment.

An adequate power-house, conductor and machinery will demand an outlay which will require for interest at six per cent. and depreciation enough annually to pay the interest on the value of a passenger locomotive and leave enough to pay for all the coal which it would need to pass over the line one way each hour 12 times a day. The labor cost of running the locomotive would manifestly be less than the combined expense of manning the motor and power-house, besides saving the entire fuel cost of the generating plant. But if a service every 15 minutes is needed the interest would figure but a small fraction of the locomotive fuel per mile, and even this will be much further reduced by running the plant seven days a week, more than 15 hours a day, and if the house has been well placed the chances are that additional lines radiating in other directions will contribute further economical results.

There is evidently little or no economy to be expected from electricity under such conditions as have been assumed, unless the business justifies more than an hourly service, and as this is seldom the case away from large places electricity, like compressed air, promises no improvement in the cost of operation, and we remain dependent upon the locomotive for the majority of our territory.

Let us examine the passenger-train loads by dividing the number of passengers carried one mile by the number of passenger-train

miles run by the roads terminating in Boston. We thus obtain an average passenger-train load for the

	Passengers.
N. Y., N. H. & H	73
Boston & Albany.....	70
Boston & Maine.....	59
New England.....	47
Fitchburg	47
B., R. B. & L.....	43

No road in the country exceeds in passenger business per mile the Boston & Albany and New York, New Haven & Hartford roads. It therefore appears that the average number of passengers carried in one train upon the best passenger roads in the country could be sealed in one of their largest coaches.

If the average gross weight of trains on the New England Railroad is distributed among the average load of 47 passengers the present method of locomotives shows about 7,500 lbs. dead weight moved for the accommodation of each passenger.

A statement of the passengers carried upon the various passenger trains of the New England road preliminary to a new time-table, and for the purpose of disclosing the average number of passengers carried upon the different trains, located about 325,000 passenger-train miles per year, carrying less than 25 passengers each, some averaging as low as six. While the obligation of the company to

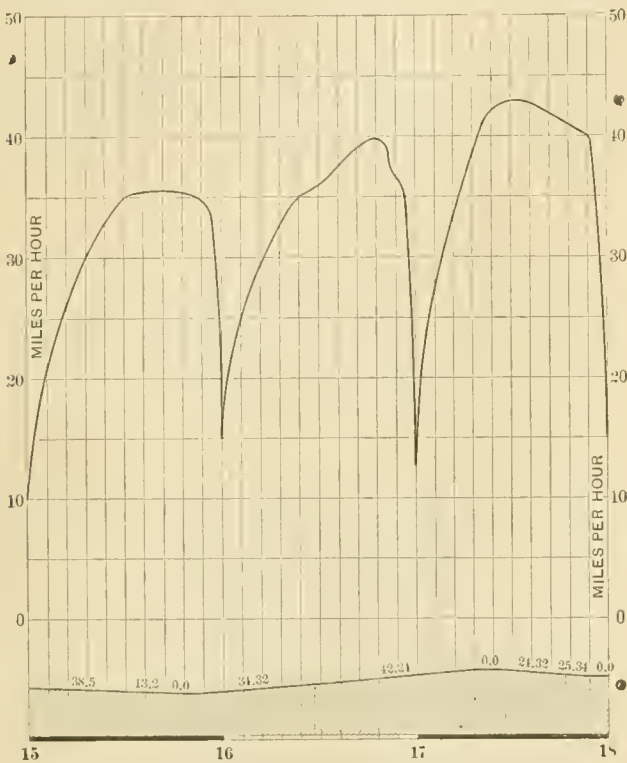

Diagram of Three Stops One Mile Apart.

transport was recognized, the great loss of money in connection with this transportation naturally received careful attention. That public convenience would not admit of any substantial reduction in service was evident upon examination of each individual case. The necessity of reducing expenses was apparent and urgent, the property not having paid any dividend for six years.

Inquiry failed to suggest a vehicle suited to the conditions. If the steam locomotive must be run, it should be one capable of working economically, with a burden suitable for the transportation of not over a earload of passengers. These conditions suggested the old steam dummy, and an examination of one of the number manufactured for street service about 20 years ago was made. The limited speed at which it could comfortably travel was certainly against it, and the extremely disagreeable rocking and swinging motion caused by the excessive overhang of car body, aggravated by the reciprocating motion from the cylinders connected to the sides of the car, gave little encouragement in this direction. While the whole subject was in this indefinite condition, the President and Vice President of the Schenectady Locomotive Works took up the question, which resulted in the building of the composite car. [The work was done, as we understand it, by consultation with Mr. Clark.—Ed.]

The Reagan water grate, similar to that used on the *Paris*, was adopted, and is giving good satisfaction. A slight movement of a handle behind the engineer's seat is all that is necessary to furnish a fresh fire over the entire grate surface, no poker or other tool being required for either coke or anthracite. The fuel now used is coke.

The boilers are fed by two Hancock inspirators, the smaller of which is practically allowed to work without interruption. The Westinghouse quick-acting brake is used on all wheels, and in connection with the so-called "Composite" brakeshoe containing seven cork inserts, gives a most satisfactory and finished braking power. A service stop from a speed of 40 miles an hour is easily

made in less than 500 feet on level track, with no suggestion of inconvenience to those standing in the car. [Our engraving shows three starts and stops made by the car, the last of which is the one referred to here. The horizontal distance is divided into three separate miles.—Ed.]

The composite car can be turned on a common wooden table furnished with ordinary wheels. Of course, the most expeditious and satisfactory way where land is obtainable, is to lay a small loop or "Y." The present composite will easily run around a loop of 200 feet radius.

The best record for speed thus far attained is a mile in 61 seconds or 59 miles an hour. This requires 472 revolutions of the 43-inch drivers every minute. The longest runs which have been taken are between 100 and 120 miles.

The water carried will last about 50 miles on fairly level track, and the coke bin carries fuel enough for a 100-mile run. The machine has ample power to haul at least one passenger, coach, and in an emergency was called upon to move 11 freight cars, which was done without apparent effort.

The service application of the brake upon a level track gives a comfortable stop from 40 miles an hour in less than 500 feet, while a stop made entirely by the conductor's valve in the rear compartment of the car, with the throttle wide open and the reverse lever in usual running position, speed indicator showing 27 miles an hour, resulted in a stop in less than 250 feet in 14 seconds.

Not only does the composite with these qualifications appear able to cover all mileage where the maximum number of passengers to be handled is within its limits, but possibly increase the gross revenue, and at the same time net earnings, by permitting the subdivision of some trains at present self-sustaining, but which do not represent the full travel which might be developed by a more frequent service.

The composite car has run 12 miles without having the door of the firebox opened. This indicates little need of a fireman if the engineer upon a private right of way can properly be allowed as much responsibility as is placed upon a motorman operating the heavy electric cars in city streets, with nothing but hand-brakes, and among the teams, crossing numerous blind street corners.

Locomotive Building in the United States—1897.

From the statements received from the locomotive building firms of the United States covering the number of locomotives built during the year 1897 it appears that a total of over 1,000 have been built. We have not received the returns from two firms, which would probably increase the number to about 1,100. The seven most prominent builders report a total of 1,052 locomotives, of which 225 were for export.

Of those built for domestic service 271 are of the eight-wheel type, 282 have three driving axles and are of the mogul and 10-wheel types, 92 are of the consolidation type, four are of the six-wheel connected type, 15 are of the 12-wheel type, 86 are switchers and others are of miscellaneous types.

As 1897 must be considered an off year as regards the building of new equipment the record is satisfactory. It would be equally interesting to examine figures for the number of cars built during the year, but as the returns are not all available at this time it will be impossible to state the number until later.

The following statement with regard to the advantages of using gas engines for electric lighting purposes is given by *La Lumière Electrique*:

1. The facility with which gas can be obtained from existing sources.
2. The gasworks themselves may be used as a central station.
3. It has been shown that one cubic meter of gas gives—
 - (a) In an ordinary gas burner of 16 candle power, a maximum of 91 candle hours.
 - (b) In an incandescent electric lamp, a minimum of 162 candle hours.
 - (c) In a Wepham lamp, a maximum of 200 candle hours.
 - (d) In an arc lamp, a minimum of 654 candle hours.
4. If the electric lighting were carried out by the gas company, a smaller staff will be needed than in the case of an independent company, with which the advantages of combining both systems of supply, thus obviating competition, should be considered; and further, the gas supplied to the engines would, under these conditions, be obtained at the cost of production, and not at the selling price.

Mr. A. Zdarski has recently been appointed Assistant Chief Engineer of the Great Siberian Railway, with headquarters at St. Petersburg, Russia.

Consolidation Locomotive—Mexican Central Railway.

It will be interesting to compare the dimensions of the large freight engines for the Mexican Central Railway, illustrated in our issue of November, 1897, page 371, with another design by the same builders, the Brooks Locomotive Works, which is somewhat lighter and of the consolidation type. Ten of these consolidation engines have been built, and the general appearance is almost identical with the heavier type, except that the trailing wheels have been omitted. The chief dimensions of the new engines are as follows:

Gage.....	4 feet 8½ inches
Fuel.....	Coal or wood
Weight on drivers.....	160,000 pounds
" truck wheel.....	20,000 pounds
" total.....	180,000 pounds
" tender, loaded.....	90,000 pounds
Heating surface, firebox.....	204 square feet
" tubes.....	2,140 square feet
" total.....	2,344 square feet
Grate area.....	31.5 square feet
Wheel base, of engine.....	23 feet 5 inches
" driving.....	15 feet
" total.....	50 feet 9¼ inches
Length over all, engine.....	35 feet 2 inches
" and tender.....	53 feet 7 inches
Height, center of boiler above rails.....	9 feet 2 inches
of stack.....	15 feet 4½ inches
Drivers diameter.....	57 inches
" material of centers.....	Cast steel
Truck wheels, diameter.....	28 inches
Journals, driving axle.....	8½ inches diameter by 11 inches
" truck.....	5 inches by 10 inches
Main crank pin, size.....	6½ inches diameter by 6½ inches long; coupling, 7¾ inches diameter by 5 inches long
Cylinders.....	21 inches by 28 inches
Piston rod, diameter.....	4 inches
Steam ports, length.....	18½ inches
" width.....	1½ inches
Exhaust ports, length.....	18½ inches
" width.....	3 inches
Bridge, width.....	1½ inches
Valves, kind of.....	Richardson balance
" greatest travel.....	6¼ inches
" outside lap.....	1 inch
" inside lap.....	Line and line
" lead in full gear.....	Line and line
Boiler, type of.....	Player improved Belpaire
" steam pressure.....	180 pounds
" thickness of material in barrel.....	Steel 1½, ¾, ¾, ¾ inches
" diameter of barrel at smokebox.....	74 inches
Seams, kind of horizontal.....	Sextuple riveted lap
" circumferential.....	Triple riveted lap
Thickness of tube sheets.....	¾ inches front, ¾ inches firebox
" roof sheet.....	¾ inches
Crown sheet stayed with.....	Improved direct stays
Dome, diameter.....	31¼ inches
Firebox, length.....	120 inches
" width.....	37¾ inches
" depth front.....	80 inches
" back.....	73 inches
" material.....	Steel
" thickness of sheets.....	Flue, ¾ inches; crown, ¾ inches; sides and back, ¾ inches
" mud ring.....	1 inches thick, double riveted
" water space, width, front, 4 inches; sides, 1 inches; back, 4 inches	
Tubes, number.....	374
" material.....	Iron No. 12 B. W. G. thick
" outside diameter.....	2 inches, pitch 2¾ inches
" length over sheets.....	11 feet 1½ inches
Tender, tank capacity for water.....	4,500 gallons
" coal capacity.....	9 tons
Thickness of tank sheets.....	¾ and ¼ inches
Type of under-frame.....	9 inch channel steel
Type of truck.....	"Robinson" rigid bolster
Diameter of truck wheels.....	33 inches
Axle journals.....	4¼ by 8 inches

The wheel centers were made by Pratt & Letchworth, the tires by Krupp, the sight feed lubricators and the injectors by the Nathan Manufacturing Company, the brakes by the Westinghouse Air Brake Company, the springs by the Charles Scott Spring Company and the Le Chatelier water brake by the Brooks Locomotive Works.

Reduction in Cost of Steam Power from 1870 to 1897.*

BY F. W. DEAN.

In the year 1870 the most economical steam engine in use in mills was the Corliss simple condensing engine which used 19 or 20 pounds of steam per horse-power per hour. Previous to that time compound engines had been used in England in mill practice, and simple engines had in many cases been changed to compound.

The Pawtucket pumping engine, built by George H. Corliss, and started on June 30, 1878, is another important example of economical pumping engines, and probably was the most economical steam engine which had been built up to that time, having used less than 14 pounds of dry steam per indicated horse-power per hour.

* From a paper presented at the New York meeting (December, 1897) of the American Society of Mechanical Engineers.

In 1873 the most economical compound engines used about 16½ pounds of steam per indicated horse-power per hour, as shown by tests of the Lynn and Lawrence pumping engines, which then established new records for duty. Improvements in methods of using steam were made until it is now as easy to design an engine to use less than 13 pounds of feed water per horse-power per hour as it was to use as little as 16 pounds in 1875.

At this date steam jackets were common, and were used in all engines which gave the most economical performances. The steps, however, that lowered the steam consumption of compound engines from 16 pounds to 11 pounds per indicated horse-power per hour were largely the introduction of a cut-off on the low-pressure cylinder and a reheating receiver between the cylinders.

These features appear to have been the principal means of lowering economy to 14 pounds of steam; but to what are we to attribute the step to 13 pounds? Clearance is well known to be an important factor, and its reduction, especially in the last cylinder of a series, is important for economy. It is receiving constant attention from careful designers, and its reduction is a constant source of gain.

The 13-pound mark has also been reached by an increase in steam pressure, with resulting increase in the number of expansions. In some cases a reduction in the size of the high-pressure cylinder has doubtless contributed toward economy, by means of which smaller surfaces are exposed to the boiler steam than would otherwise be the case. This carries with it a proportional reduction of initial condensation in the cylinder, which is most prolific in this cause of waste.

Still further, the 13-pound mark has in general been attained by engines which have a low-pressure cylinder larger for the work to be done than is commonly the case, so that the mean effective pressure referred to the low-pressure cylinder is in the vicinity of 21 pounds.

There is a strong tendency nowadays to underrate steam jackets, but I believe that in every case where they have been wasteful, or where their economy is indifferent, at all events with ordinary speeds, an examination would show that the jackets are air-bound, water-logged, blowing through traps, or that the jacket piping is bare, and thus steam for heating the building is charged to the engine. Such an arrangement of pipes can furnish but indifferent material for giving up latent heat to the working fluid within the cylinders, and is, in fact, absurd.

The effect of reheaters in drying out steam which issues from a preceding cylinder and in superheating it to 60 degrees or 90 degrees, as is often the case, for use in the next cylinder, cannot be otherwise than advantageous, for, as Professor Thurston shows in his paper of 1891 before this Society, heat so added to the working fluid saves much more steam than was condensed to liberate this heat.

Considering economies effected, it is safe to say that, without including triple-expansion engines, steam economy has steadily decreased from 20 to 12½ pounds per indicated horse-power between 1870 and 1897. This corresponds to a saving of $\frac{20 - 12\frac{1}{2}}{20} = 37\frac{1}{2}$ per cent.

The horizontal return tubular boiler is still the standard of the country, and will probably so remain. It is cheap, and if properly built it is safe.

There is scarcely any improvement to be noted in the horizontal return tubular boiler during the last 27 years as far as economy is concerned, but I believe that grates have been improved to a measurable extent, resulting in an economy of perhaps 2 per cent.

My own experience teaches me that the internally fired boiler, either of the locomotive or vertical type, will save under equal conditions some 7 per cent. of coal compared with the horizontal return tubular boiler, besides causing an important economy in doing away with brickwork.

Mr. Bryan Doukin, in a recent paper before the Institution of Civil Engineers, in discussing boiler economies, says: "Generally speaking, internally fired boilers give a higher efficiency than those externally fired. The old and well-known locomotive type, with smoke tubes and induced draft, stands high as a very economical steam generator." Such praise from so careful an investigator as Mr. Doukin should carry great weight.

Within 27 years economizers for heating feed water in smoke flues have become common. Although subject to a rather large depreciation, in the general case they will save about seven or eight per cent. of coal.

There are economies to be obtained from the use of vertical engines. These come from reduction of friction, reduction of repairs to cylinders and pistons, and diminished cylinder oil consumption. It would not surprise me if there were a net saving of five per cent. by reduced friction of a vertical compound compared with a horizontal engine.

Summing up the various items that have been mentioned, the following may be presented as the economies of the period from 1870 to 1897:

Saving due to compounding, jackets, reheaters, higher pressures and greater expansions.....	37 per cent.
Due to vertical engines.....	5 " "
Due to vertical internally fired boilers.....	7 " "
Due to economizers.....	7 " "
Due to improved grates.....	2 " "

It seems probable that the relative economies of the compound engine, using 160 pounds, and the triple, using 185 pounds of steam, are to day represented in the very best practice by 12½ pounds of steam and 11¼ pounds of steam respectively per indicated horse-power per hour. This corresponds to a saving of $\frac{12\frac{1}{2} - 11\frac{1}{4}}{12\frac{1}{2}} = 8.16$

per cent., which is a paying saving.

The future, so far as we can now see, offers us highly superheated steam for further means of economy. The technical papers have frequent accounts of the use of such steam in Germany, and

published tests (see *Engineering*, pages 113, 391, 1895) show that a small Schmidt "motor" has used 10.17 pounds of steam per indicated horse-power per hour. It would seem that we have a right to anticipate in the early future a steam rate of 10 pounds by means of superheated steam in the best designed engines. Compared with the lowest rate thus far mentioned, this corresponds to

a saving of $\frac{11\frac{1}{4}}{11\frac{1}{4}} - 10 = 11.11$ per cent.

We have also in anticipation the use of very high steam pressure and quadruple-expansion engines as built experimentally at Cornell University and described by Professor Thurston last year before this Society. If, however, steam can be so highly superheated that expansion in one cylinder will not cause condensation, nor even the saturated condition until the time of exhaust, as was the case in the Schmidt motor, extreme economy may be obtained without resort to the multiple expansion engine.

The economies thus far mentioned relate to improvements in engines and boilers; but one of the greatest economies results from the low cost of coal at present in Lowell, Lawrence and similarly located towns.

The prices of coal in these places every five years were as follows:

Year.	Price.	Kind of coal
1870.....	\$7.10.....	Anthracite
1875.....	7.20.....	"
1880.....	4.75.....	Bituminous
1885.....	4.23.....	"
1890.....	4.85.....	"
1895.....	3.85.....	"

These prices show a saving from 1870 to 1895 by themselves of about 46 per cent.

The very best steam plant of 1,000 horse-power in most mill towns in the State of Massachusetts away from tidewater 27 years ago, including a pair of simple condensing engines using 20 pounds of steam, boilers evaporating eight pounds of water on total coal used, buildings, chimney and all accessories, cost \$70 an indicated horse-power.

The very best plant of 1,000 horse-power can be installed to-day complete, including buildings, chimney, compound engine using 12.5 pounds of steam, boilers evaporating 9 pounds of water on total coal used, economizers, and all accessories, for \$57 per indicated horse-power.

Such a plant can run on 1.4 pounds of coal per indicated horse-power per hour for total coal consumed.

The saving by using a feed water heater in connection with a vertical cross-compound engine of about 1,000 horse-power at the Atlantic Cotton Mill, Lawrence, Mass., was given as follows:

A feed-water heater was placed in the low-pressure exhaust pipe near the low-pressure cylinder, and the temperatures of the water as it entered and left were taken. The average increase in feed-water temperature caused by the heater for the two days is 65½ degrees, which under the present conditions of temperature and steam pressure is equivalent to a saving in coal of 5.6 per cent.

The following table gives the rate of heat transfer from the steam to the water:

	First Trial.	Second Trial.
Temperature of water before entering heater....	32 deg.	32 deg.
" " after leaving.....	94 "	101 "
Increase in temperature of water.....	62 "	69 "
Average temperature of water in heater.....	63 "	66.5 "
Absolute pressure in low-pressure exhaust pipe.....	0.87 lbs.	1.36 lbs.
Corresponding temperatures exhaust pipe.....	99 deg.	111 deg.
Average difference of temperature between steam and water.....	36 deg.	44.5 deg.
Feed water used per hour.....	11,167 lbs.	13,731 lbs.
Heating surface of heater in contact with steam.....	234 sq. ft.	234 sq. ft.
Amount of heat transferred per hour, B. T. U.....	692,354	917,439
Heat transferred per degree of average difference in temperature per square foot of heating surface per hour, B. T. U.....	82	91

A Sample of Railroad Air Taken by a Chicago Commuter

He drifted into the office, looked about him curiously, walked over to the desk in the far corner, put a package down on it, and said to the man who was writing there:

"Lift it."

"Lift what?" returned the man at the desk.

"That," said the stranger, pointing to the package.

The man at the desk lifted it with an effort.

"Heavy, isn't it?" asked the stranger.

"I should say so," replied the man at the desk. "What is it?"

"That's what I came in to explain to you," said the stranger, as he drew up a chair and carefully settled himself in it. "You see, winter's coming on."

"So I've heard," returned the man at the desk.

"With winter comes cold weather. I suppose you've heard that too."

"I have."

"And in cold weather," persisted the stranger, "they shut every door and every window on every suburban train running out of Chicago, and before you get fairly out of the station, during the rush hours, when everything is crowded, you have a sick headache; three minutes later your appetite for dinner is gone, and by the

time the train has gone five miles you can feel typhoid fever coming on. Am I right?"

"You are right, but, but"—

"You instinctively recall all the articles you ever read about the value of ventilation—indeed, the absolute necessity of it to maintain health," interrupted the stranger, "and you wonder why no one else ever read any of those articles. Am I right again?"

"You are right again," answered the man at the desk, "but what has all this got to do with the weight of that package?"

"That's a sample of it," replied the stranger.

"A sample of what?"

"A sample of the air in a suburban car during the rush hour on a cold, muggy day last week. I chipped it off to bring up to you just to illustrate my remarks. And, say?"

"Well?"

"I tried to bring you a piece from the smoking-car, but after I had chipped it off I found it too heavy to carry."

Then he made a quick retreat, leaving his package, and as a result the Health Department had to be requested to fumigate the room.—*Chicago Post*.

Webb's Rail Joint, London & Northwestern Railway.

Through the courtesy of Mr. F. W. Webb, Chief Mechanical Engineer of the London & North Western Railway, we are enabled to present an engraving of the newly patented rail joint designed by him and used on that road. The drawing shows a joint as

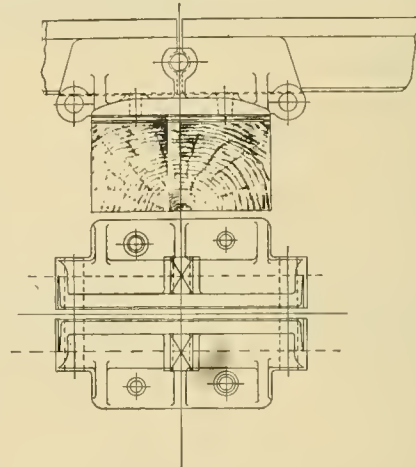

Webb's Rail Joint.

arranged for a heavy section of "T" rail, and it is noticeable that the design does not make use of bolts through the rail webs.

In the investigations which resulted in the design shown joints of lead were made and loaded by heavy locomotives in order to show the effect of loading joints that were not properly supported, as by the failure of the ballast in wet or improperly tamped track. The deflection of the lead joints gave the information which led to this form.

The splice is made of two castings, which are fitted to the base and web of the rail and also to the underside of the head. The castings form a base for the flange and are drawn together by the two end bolts and by the bolt at the center of the splice. This last-mentioned bolt passes through a hole formed half in each rail end.

It was stated by Mr. Webb in a paper read before the Institution of Civil Engineers, at the Engineering Conference a short time ago, that 95 per cent. of the rail failures on the London & North Western Railway occurred through the bolt holes and the cause was believed to be that in case of a badly tamped track either the fishplate must bend or the rail must tend to tear through the bolt holes. The form of joint devised by Mr. Webb has been adapted to the bullhead type of rail as well as to the form shown.

The New Heilmann Electric Locomotive.

The "New" Heilmann locomotive is not particularly new at this time to some of our readers, but inasmuch as several inquiries have recently been received as to the status of that com-

bination of stationary power plant and electric locomotive and because of recent tests of the engine we supplement the information given in *The National Car and Locomotive Builder* of June, 1895, as follows :

The old locomotive designed by Mr. J. J. Heilmann gave results which were perhaps more interesting than useful. It suggested to those who have designed and manufactured it that various improvements could be made in the structure and arrangement of the locomotive. Mr. F. Drouin, in describing in *L'Electricien* the new locomotive, briefly summarizes the leading characteristics of the older combination, for the translation of which we are indebted to *The Railway Engineer*. The locomotive tried in 1893 had a boiler of the Lentz type with 289 tubes. The total heating surface was 1,560 square feet, and the grate area 242 square feet, the pressure being 170 pounds per square inch. The engine was of the C. Brown horizontal compound double-acting type, developing 600 horse-power at 300 revolutions, the diameters of the high and low-pressure cylinders being 16.8 inches and 25.6 inches respectively. The dynamo was a six-pole machine, designed by Mr. C. E. L. Brown, giving 1,024 ampères at 400 volts. The diameter of the iron armature core was 47.35 inches, and the length of the core 17.5 inches. This dynamo was separately ex-

directors of the Compagnie de l'Ouest to construct two new machines of greater output and power. The designs were got out by Messrs. M. Mazen and G. Damoiseau, and embodied the following differences : (1) the substitution of an ordinary locomotive boiler for the Lentz boiler ; (2) the use of more compact electrical apparatus and of generators with toothed armatures. In fact, everything tending to reduce weight was carefully considered. The double-acting engine is replaced by single-acting ones without diminishing the output per weight, but the steam-pressure is increased by one-sixth and the speed by one-third. The following details of the new locomotive will interest our readers.

Boiler.—The boiler, as stated above, is of the locomotive type, with a Belpaire furnace and copper firebox. The heating surface of the furnace is 178 square feet, and that of the tubes 1,820 square feet. The grate area is 36 square feet, and the working pressure 198 pounds per square inch. The feed is supplied by two Friedmann injectors.

Engines.—The engines are of the Willans & Robinson type, with six lines of cylinders, which arrangement gives a good balance in turning moment. In each engine the three cranks are inclined at 120 degrees to each other. The ordinary features of the

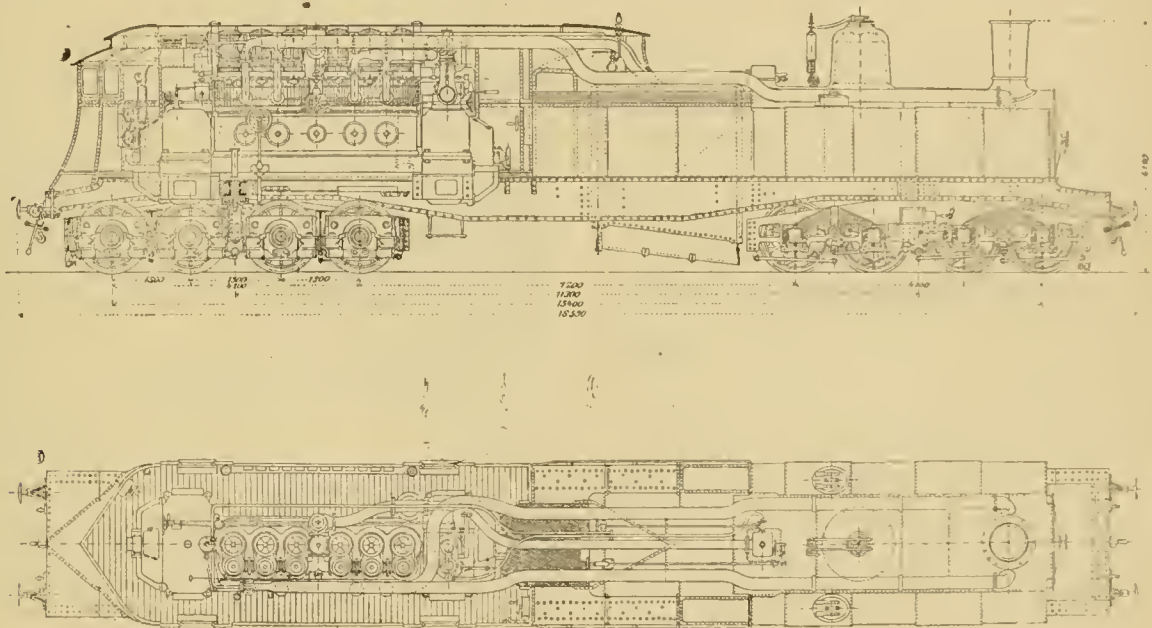

The Heilmann Electric Locomotive.

cited by a small dynamo driven independently, and required about 95 ampères at 50 volts. The motors were of the C. E. L. Brown four-pole type, series wound, with toothed armatures. The cores were 25.6 inches diameter and 15.6 inches long. The motor, when taking 128 ampères at 400 volts, gave a normal torque of 900 foot-pounds and ran at a speed of 410 revolutions per minute. There were eight of these motors. The principal dimensions of the complete locomotive were as follows :

Length between buffers.....	53 feet 6 inches
Total wheel base.....	38 feet 6 inches
Wheel base of bogie.....	13 feet 1 inch
Diameter of wheels.....	3 feet 9 3/4 inches
Breadth of frame.....	9 feet 10 inches

This first locomotive was able to give a normal effort of 2,830 pounds to the wheel, or at the speed of 63 miles per hour a pull of 2,100 pounds. It was not designed to give exceptional power, but rather to find out what the system was capable of doing. The author states that this first locomotive showed that the stability was independent of speed, and that the deteriorative effects on the permanent way was less than with a steam locomotive. The double transformation of power caused losses equal to about 15 per cent. of the indicated horse-power of the engines. In drawing a train weighing about 65 tons the consumption of coal was under 14 pounds per mile.

The results obtained from this first locomotive determined the

electric lighting engines are included, the working parts running in oil. The principal dimensions of these engines are as follows :

Indicated horse-power.....	1,350
Speed (revolutions per minute).....	400
Diameter of high-pressure cylinder.....	11.8 inches
Diameter of low-pressure cylinder.....	19 "

These engines have coupled to each extremity of their common shaft a direct-current dynamo, the armatures of which act as fly-wheels.

Dynamos.—Each of these dynamos is able to give 910 ampères at 450 volts. They are of the six-pole type, constructed by Messrs. Brown & Boveri. The field magnets are of cast steel. The armatures have toothed cores, and the current is collected by carbon brushes. The dynamos are cased in, except for a few openings for ventilation. The dynamos rest direct on the frame of the locomotive, and also form supports for the two ends of the engine bed-plate. They are excited by a smaller dynamo giving 140 ampères at 110 volts, but only 10.0 ampères are required for the dynamo field magnets.

Motors.—These are of the four-pole enclosed type with toothed armatures mounted on a hollow shaft connected with the driving axle. The axle is thus able to follow the inequalities of the road without transmitting shocks to the armature. The approximate concentricity of the axle and armature shaft is obtained by three double steel springs connected to one of the wheels. The frame

of the motor consists of four essential parts. The lower part has the two feet which fix the motor to one frame of the bogie, and carries also the two bearings in which the hollow shafts revolve. These bearings are automatically lubricated. The two horizontal cores carrying the series exciting coils form the next two parts, and the upper piece completes the structure. The exciting conductor is formed of copper tape wound in two sections.

Controlling Gear.—The locomotive can be worked from either of two positions, depending on which way the train is running, the over-all dimensions being as follows:

Length between buffers.....	60 feet 7 inches
Total wheel base.....	50 feet 6 inches
Wheel base of bogie.....	13 feet 5½ inches
Diameter of wheel.....	3 feet 9½ inches

The first of these locomotives was subjected to a preliminary trial in January last, but no trial of speed was made. As reliable figures are likely to be obtained shortly we refrain from giving our readers calculated figures only. The designers expect to get a full load efficiency of 73.4 per cent.—that is, 73.4 per cent. of the indicated horse-power of the engines is expected to be available on the axles. The locomotive without tender weighs about 120 tons. The accompanying engravings are reproduced from *Glasger's Annalen*.

A run was made with the engine November 12 from St. Lazare Station in Paris to Nantes and return. The speed was 18 miles per hour and the train weighed 150 tons. The trial was considered satisfactory and the speed was limited very strictly by the railroad company. The length of the machine was so great that it could not be turned on the turntables, and it is understood that its cost is so high that the promoters do not expect to sell to railroads, but the locomotives are to be offered for hire upon favorable terms.

EQUIPMENT AND MANUFACTURING NOTES.

The Richmond Locomotive Works are building five freight locomotives for the Wabash.

The Pennsylvania has decided to build 15 consolidation engines for the western lines at Juniata shops.

The Schenectady Locomotive Works have orders for two switching engines for the Union Stock Yards Transit Company, of Chicago, two more 20 by 26-inch consolidation engines for the Grand Trunk, one fast passenger engine for the New England for the New York and Boston five-hour train, 10 mogul 20 by 28-inch engines for the New York, New Haven & Hartford, eight mogul locomotives for the Boston & Maine, and several freight and passenger locomotives, the exact number not known, for the Northern Pacific.

The Dickson Locomotive Works have orders for five 21 by 23 inch consolidation locomotives for the Atchison, Topeka & Santa Fe Railway and for two 6-wheel switching locomotives, to go to the Sanyo Railroad, Japan.

The Brooks Locomotive Works will build for the following roads: Pittsburgh, Bessemer & Lake Erie, two locomotives; C., C., C. & St. L. Railway, six switching locomotives; Reynoldsville & Falls Creek one 19 by 24-inch mogul and for the Wisconsin Central six 10-wheel freight and four 10-wheel passenger locomotives.

Locomotives have been ordered from the Pittsburgh Locomotive Works by the following roads: the Louisville, Henderson & St. Louis, two locomotives; Pittsburgh, Bessemer & Lake Erie, four locomotives; the Wabash, five freight locomotives; the Arkansas & Choctaw, one mogul locomotive.

The following orders have been taken for locomotives by the Baldwin Locomotive Works: The Evansville & Richmond, three 8-wheel engines; the Iowa Central, two 6-wheel switchers; Intercolonial of Canada, the World's Fair Baldwin exhibition locomotive; the Southern Indiana, three passenger locomotives; the Kansas City, Pittsburgh & Gulf, 15 10-wheel locomotives with 20 by 26-inch cylinders; the Wabash, one Atlantic type passenger locomotive and five freight locomotives; the St. Louis, Peoria & Northern, two 8-wheel passenger locomotives; the Kanawha & Michigan, three moguls to be built in 30 days; the Baltimore & Ohio, 20 consolidation locomotives; the Norfolk & Western, six

2-cylinder compounds; the Denver & Rio Grande, two 10-wheel freight engines.

The Cooke Locomotive Works are building a 10-wheel locomotive for the Bangor & Portland Railroad for freight service.

The Baltimore & Ohio is about to contract for 5,000 new freight cars.

The Detroit, Grand Rapids & Western has ordered 250 freight cars from the Michigan Peninsular Car Company.

The Great Northern has ordered 10 combination and 16 tourist cars from the Barney & Smith Car Company, of Dayton, O., and the Colorado & Northwestern is reported to have ordered four passenger and combination cars from the same firm.

The Canadian Pacific has contracted for 20 passenger cars with the Crossen Car Manufacturing Company, of Cobourg, Ont.

The Vandalia has ordered 100 freight cars from the Missouri Car & Foundry Company.

The Allison Manufacturing Company, of Philadelphia, has received an order for 350 freight cars for the Central Railroad of Brazil.

The Chicago Great Western has ordered 100 Rodger ballast cars of the Rodger Ballast Car Company. These will be accompanied by four plow cars or distributors.

The Chicago & West Michigan has ordered 150 cars from the Michigan Peninsular Car Company. They will have Chicago rabbetted grain doors and security lock brackets.

Pullman Palace Car Company has orders for 300 stock and 200 box cars from the Omaha, Kansas City & Eastern. This firm also secured the order for 20 combination cars for the Long Island Railroad, for 300 box cars for the Chicago Great Western, and 200 box cars for the Kansas City, Memphis & Birmingham.

The Alton Terminal Railroad is having 100 freight cars built by the Indianapolis Car & Foundry Co.

Wells & French have an order for 50 refrigerator cars for the Union Pacific, Denver & Gulf.

The Southern Indiana has ordered 150 flat, 50 coal and 25 box cars from the Barney & Smith Car Company.

The Laconia Car Co. has an order for 500 box cars from the Boston & Maine.

Five hundred freight cars will be built by the Pennsylvania at Altoona, for its Eastern lines.

The Arkansas & Choctaw has ordered 30 new logging cars, which are to have Westinghouse brakes and Trojan couplers.

The Atchison, Topeka & Santa Fe will build 250 refrigerator cars and 100 50-foot furniture cars at its own shops.

The Pullman Palace Car Company has an order from the Duluth-Missabe & Northern for 400 60,000-pound ore cars.

The Pittsburgh, Bessemer & Lake Erie has ordered 100 35-foot 60,000-pounds capacity box cars from the Ohio Falls Car Company.

The special business of the Baltimore & Ohio for Sunday, Dec. 12, amounted to 18 parties, with a total of 740 people.

The pay of the general office employees of the Missouri Pacific at St. Louis has been restored to the extent of the cut of 10 per cent. in 1893.

The boiler lagging for the new experimental locomotive at Purdue University is Messrs. Keasbey & Mattison's magnesia sectional covering. The same insulation is used on the cylinders.

The Q & C Company has just made arrangements with the National Railway Specialty Company for a license to manufacture the Rear Edge Protecting Strip, which will be called the "N. R. S. Protection Strip." It may be used with the Q & C doors.

Continuous activity is noted among manufacturers of Car Material. Some heavy orders for axles, channels, etc., have recently been placed. More inquiries for cars, says the *Iron Age*, are in the market and further business is assured in this direction.

The Baldwin Locomotive Works has an order for building 56 motor car trucks for the Metropolitan West Side Elevated Railroad of Chicago. They will be built to designs by the road and will accommodate motors of a larger capacity than those at present in use.

The Chicago Pneumatic Tool Company has received an order for two No. 2, two No. 3 and two No. 4 pneumatic hammers and one piston air drill from Mr. W. E. Dixon for the Sormovo Locomotive Works at Nijni Novgorod, Russia. This is the third order for these tools from this concern.

The Freight Car Door Fastener, manufactured by the Dayton Malleable Iron Company, of Dayton, Ohio, is having an extraordinary sale; recent orders aggregate 15,792 sets. The total sales of this device amount to over 250,000 sets, and it is said to be giving universal satisfaction.

The bid by the Bath Iron Works, of Bath, Me., for the construction of the naval practice ship was the lowest offered and it is expected that the contract will be awarded them.

Several daily papers of Dec. 20 stated that the Delaware, Lackawanna & Western had the equipment of its Morris & Essex division with electric power under consideration. We are informed in a communication from Mr. Samuel Sloan, President of the road, that the reports are untrue.

The National Electric Car Lighting Company is progressing rapidly with the equipment of cars on the Atchison, Topeka & Santa Fe Railway under the contract for lighting 50 cars with their system and we are informed that another contract has been taken recently from an Eastern road for the same system.

An excellent and gratifying condition of business in the car heating line is reported by Mr. William C. Baker. The orders continue to come in and he has been obliged to increase the factory force in order to supply the demand.

The Reading Car Wheel Company, of Reading, Pa., have been granted a charter under the laws of Pennsylvania, with a capital of \$50,000. The Directors are Messrs. Herbert H. Hewitt, President; John J. Albright and Edmund Hayes, of Buffalo, N. Y., and Chas. H. Dubock and H. W. Cram, of Reading. Mr. Hewitt and other officers of the company are also with the Union Car Works, of Depew, N. Y.

The battleship *Iowa*, the gunboat *Newport* and the torpedo boat *Foote* have been finally accepted by the Navy Department, and Secretary Long has directed that all reserves be paid to their builders, the Cramps, the Bath (Maine) Iron Works, and the Columbian Iron Works, Baltimore, respectively.

We are informed that in the specifications for the following freight cars recently ordered the Chicago Rabbeted Grain Door and the Security Lock Bracket were required; 250 cars, Illinois Central, building by the St. Charles Car Company; 1,000 cars, Illinois Central, by Haskell & Barker; 250 cars, Illinois Central, by Missouri Car and Foundry Company; 250 cars Detroit, Grand Rapids & Western, by Michigan Peninsular Car Company.

The Westinghouse Electric and Manufacturing Company has received an order for the equipment of the traction tramways of Glasgow, Scotland, with electrical machinery. This includes the car and power-house equipment. This company also has a contract for a large lighting plant for Malaga, Spain, and several for electrical machinery for Niagara Falls and Buffalo. The latter contracts amount to nearly \$1,000,000.

Messrs. R. D. Wood & Company, of Philadelphia, have furnished a 17-foot gap hydraulic riveter of 100-tons capacity and three powers for the new boiler-riveting plant of the Schenectady Locomotive Works. They have also taken orders for a similar riveter from Messrs. Neilson & Company, of Glasgow, Scotland, and one for a 12-foot gap riveter for the Brooks Locomotive Works, of Dunkirk, N. Y. The Baldwin Locomotive Works have also ordered portable hydraulic riveters of 15 and of 30-tons capacity from this firm.

Mr. D. Lee, Engineer Maintenance of Way of the Baltimore & Ohio lines west of the Ohio River, has been experimenting during the past year or two with slag for ballast. His plan is to put about 1 foot under the ties, and it makes very good ballast. About 18 miles of the Akron Division have been improved in this way, but Mr. Lee's preference is for gravel when it is available. During the past season on the Trans-Ohio Division he has put in 143 miles of new ballast, the principal part of which was good, clean gravel. In addition to the ballasting, the Trans-Ohio Division has had 460,981 new cross-ties, and there have been 31 miles of new 75-pound steel rail laid, replacing 60-pound rails.

The new sleeping cars that Pullman's Palace Car Company has placed in service within the past month on the Baltimore & Ohio Railroad between Baltimore and Louisville, Ky., are an improvement over those heretofore used on that line. They have large smoking rooms and an extra size ladies' toilet room, a feature which will be thoroughly appreciated by the fair sex who have had to use some of the Columbian cars hitherto run between those cities. The Chicago and New York service has been improved by the addition of seven new Pullman cars which the Pullman people say are the best they operate. They have large smoking rooms, large ladies' toilet rooms, empire deck and all the new features that the company has recently introduced.

The Composite Brake Shoe Company, of Boston, Mr. W. W. Whitcomb, President, has recently made arrangements with the Sessions Foundry Company, of Bristol, Conn., for the manufacture of the composite brake shoe with which our readers are familiar, and it is understood that the Sessions Foundry Company will look after the sale of this shoe in a large and important territory. The shoe is making a good name for itself and the Composite Brake Shoe Company is to be congratulated in securing the assistance of the Sessions people in its manufacture and sale. The performance of the composite shoes on the new steam motor car of the New England Railroad is referred to elsewhere in this issue. One of the stops for which the data are given was remarkable both in its smoothness and in the short space covered after the brakes were applied.

The American Pegamoid Company was incorporated at Trenton, N. J., December 17, 1897, with a capital of \$5,000,000. The incorporators are John A. McCall, J. J. Byers, A. W. Pope, G. I. Herbert, Edward H. Haskell, John J. McCook, John T. Collins, Col. Albert A. Pope, John R. Bartlett, Conrad N. Jordan, E. F. C. Young, Thos. A. McIntyre and Peter T. Bosten. The New York office of the company is at 11 Broadway. According to the prospectus of the company, the name "Pegamoid brand" is applied to articles treated by a process which consists of the application, in a liquid form, of a composition which, by impregnating the fibers or pores of the substances treated, has the effect of water-proofing, strengthening, sterilizing and generally protecting the material used. It can be applied to cloths, all kinds of paper—including wall papers; to hides or skins; and in the form of paint—to all iron, steel, wood and stone work. Articles subjected to this process are rendered stronger, more durable and useful. They are absolutely rot and damp proof, and are unaffected by changes of temperature or climate, while in many cases the cost is materially reduced.

Concerning American locomotives in China, Consul Read, of Tientsin, transmits the following to the State Department:

"I have the honor to report that the steamship *Lir* has arrived with the 12 Baldwin locomotives for the Tientsin-Lukouchiao (Peking) extension, and is discharging her cargo at the railway wharf at Tangku. A representative of the firm of Messrs. Burnham, Williams & Co., Philadelphia, the makers of these locomotives, is now in Tientsin to superintend their erection. Eight of the locomotives are very heavy and are of the 'mogul' type, and the order for them was secured by Messrs. Burnham, Williams & Co. last September, this firm having tendered at prices far below those submitted by English firms. The other four are switch engines, and were ordered outright without a call for tenders. It is a matter of great satisfaction that the new line is equipped with American locomotives. We can rest assured that Messrs. Burnham, Williams & Co. have laid down locomotives that will be, in every respect, according to specifications, and that will more than meet the expectations of the railway officials. I trust that we may, with regard to future extensions of the railway, hold the vantage-ground that is now ours. The next order for locomotives will be for the Lukouchiao Paotingfu extension. This extension will be rapidly pushed as soon as the line to Peking has been double-tracked."

The formation of a gigantic wood-working machinery combination was announced in our December issue. We are informed that this failed on account of the Fay-Egan concern of Cincinnati. An other trust is announced as having been organized in Jersey City. The incorporation papers place the capital at \$4,000,000, divided into 40,000 shares of \$100 each; 20,000 shares are preferred stock, and they will draw interest at seven per cent., either semi-annually or annually before any dividend is declared. The incorporators named in the papers are Charles N. King, Nelson R. Vanderhoff, Samuel D. Dickinson, Robert S. Jordan and John J. Mulvaney, of

Jersey City; Ralph D. Parrott, of Metuchen; Charles A. Senior, Jr., and William R. Robins, of New York; George A. McGlone, of Bolivar, W. Va., and Somervall Solomon, of New York. The following statement was given out by one of the incorporators:

"This company has purchased and owns a number of the oldest and most successful concerns engaged in the manufacture of wood-working machinery. The plants are in the Eastern, Middle and Western States. They will be operated under one management. The Board of Directors include some of the most successful and able manufacturers and managers in the business. The officers of the company are: President, William Duryea, of New York; First Vice-President, A. D. Hermance, of Williamsport, Pa.; Second Vice President, Henry C. Baker, of Philadelphia; Treasurer, R. W. Perkins, of Norwich, Conn.; Secretary, Frank W. Duryea, of New York City. It is stated that a storehouse will be built in Jersey City as soon as a site can be secured. The company announces that it intends to thoroughly exploit the foreign field."

Cable orders were received by the Chicago Pneumatic Tool Company for 56 of their machines during the month of October, and the foreign business of the company is developing so rapidly as to necessitate additions to the capacity of the works in order to keep up with the demand. The orders have continued to come in from abroad so rapidly as to make the foreign work a very important branch of the business and the progress made in England and on the Continent is shown in a partial list of concerns now using pneumatic hammers and piston air drills furnished by this company, which comprises 16 prominent railroads and 60 widely known firms of engineers and shipbuilders. Through the courtesy of Mr. John W. Duntley, our representative, was allowed to read this list, and we would recommend any who entertains doubts as to the efficiency of the machines to examine the list, than which no stronger proof of their eager reception in Europe could be asked. Among letters from users of the tools in the United States our representative was permitted to see two that are specially good, from the Wm. Cramp & Sons Ship and Engine Building Company, of Philadelphia; and from the Bigsaw Company, of New Haven, Conn. Pneumatic tools have apparently taken the shipbuilders by storm; they fit in specially well in operations that were formerly done at great expense by hand. These concerns cannot afford to fool with appliances that will not stand up to the work and the advent of air tools into heavy work, both marine and otherwise, seems likely to show the same economic effects as followed their introduction into railroad work. This firm has recently perfected an improved pneumatic machine for rolling and expanding flues, driving boring bars and furnishing power for similar operations about engines and boilers. The machine will be illustrated and described in a future issue of this journal, meanwhile it is sufficient to say that it consists of two 2 by 3 inch oscillating cylinders for the power and a feed cylinder with 12 inch stroke. It will cut, roll and expand flues at a rapid rate, saving, it is said, about 72 hours over hand work per locomotive boiler. Two hundred and fifty flues have been cut in one hour and 250 have been expanded in three hours. The advantage of cutting the flues close to the sheet is an important one, the cut being as close as $\frac{3}{4}$ inch from the sheet when desired. This is a powerful machine and yet it is light enough to be easily transported and used.

Our Directory

OF OFFICIAL CHANGES IN DECEMBER.

Baltimore & Ohio.—Mr. John K. Cowen was re-elected President at a recent meeting of the Board.

Boston Elevated.—Mr. J. A. L. Weddell, M. Am. Soc. C. E., of Kansas City, Mo., has been appointed Consulting Engineer, and Mr. George A. Kimball, M. Am. Soc. C. E., Exchange Building, Boston, has been appointed Chief Engineer.

Boise, Nampa & Owyhee.—Mr. John E. Stearns has resigned as General Manager.

Caraballa, Tallahassee & Georgia.—Mr. W. A. Simmons has been elected President.

Central of Georgia.—Mr. W. H. Stulb, Master Mechanic at Augusta, Ga., has been appointed Master Mechanic at Macon, Ga., to succeed Mr. John Dempsey, resigned. Mr. J. H. McCann is appointed Master Mechanic at Augusta.

Chicago & Southeastern.—Mr. A. C. Campbell, of St. Louis, Mo., has been appointed Receiver by the Supreme Court. He will move the offices from Anderson, Ind., to Brazil, Ind.

Cincinnati, Hamilton & Dayton.—Mr. A. D. McCallum has been appointed Master Mechanic at Hamilton, O.

Columbus, Sandusky & Hocking.—Mr. T. M. Downing has been appointed Master Mechanic, with headquarters at Columbus, O.

Danville & Mount Morris.—Mr. M. F. Lapp, Purchasing Agent and Acting Superintendent, with headquarters at Danville, N. Y., has been appointed Superintendent, with headquarters at the same place, succeeding B. F. Humphrey, resigned.

Duluth, South Shore & Atlantic.—Mr. J. J. Conolly has been given the title of Superintendent of Motive Power and Machinery. He was formerly Master Mechanic of this road.

Ferro-Carril Central.—Mr. Alberto Villasenor has been appointed Master Mechanic, with office at Salvador, C. A.

Florida Central & Peninsular.—Capt. D. E. Maxwell has been elected Vice-President, retaining also the position of General Manager.

Fitchburg.—After Dec. 1 the headquarters of Mr. J. Medway, Superintendent of Motive Power, now at Boston, Mass., will be located at Keene, N. H.

Fonda, Johnstown & Gloversville.—Mr. P. E. Garrison has been appointed Master Mechanic, with headquarters at Gloversville, N. Y.

Georgia.—Mr. C. H. Phinzy has resigned as President, and is succeeded by Mr. J. Phinzy, and Mr. L. Phinzy, a brother of the new President, was chosen Vice-President.

Georgia & Alabama.—The office of Mr. Cecil Gabbett, Vice-President and General Manager, has been removed from Americus to Savannah, Ga.

Intercolonial.—Mr. C. R. Palmer has been appointed Purchasing Agent, vice Mr. Thos. V. Cooke, resigned.

Maine Central.—Mr. George F. Evans was chosen Vice-President at a recent meeting of the Board of Directors. He is also General Manager.

Mexico, Cuernavaca & Pacific.—Mr. J. A. Chisholm has been appointed Chief Engineer, with headquarters at the City of Mexico, vice Mr. H. H. Filley, resigned.

Mexican National.—Mr. W. F. Galbraith, Master Mechanic, has changed his headquarters to Santiago, Mex.

Mississippi River & Bonne Terre.—Mr. J. Burns has resigned as General Superintendent.

Missouri, Kansas & Texas.—After Jan. 1 this road will be operated from the Texas offices, in Dallas, Tex., to which point Vice-President and General Manager A. Allen will move his office, now at St. Louis, Mo.

New Orleans & Northwestern.—Mr. Louis K. Hyde, Receiver for the company, has been elected Vice-President, and Mr. Frank Delancey Hyde, formerly First Vice-President, has been elected Second Vice-President.

New York & Ottawa.—Mr. E. La Lime has resigned as Superintendent and Master Mechanic, and taken the position of Master Mechanic of the Ohio River Railroad.

Oregon Improvement Company.—Mr. C. J. Smith, Receiver, has been made General Manager of the Pacific Coast Company, under which name a reorganization of the Oregon Improvement lines has been effected.

Oregon Railroad & Navigation Company.—Col. William Crook has been appointed Chief Engineer. He was formerly Chief Engineer of the Minneapolis & St. Louis.

Ohio River.—Mr. W. W. Layman has resigned as Master Mechanic and is succeeded by Mr. E. La Lime.

Omaha, Kansas City & Eastern.—Mr. Ira C. Hubbell has been appointed Purchasing Agent. He holds the same position on the Kansas City, Pittsburgh & Gulf and the Omaha & St. Louis Railroad. Mr. John M. Savin has been appointed Assistant General Manager and General Superintendent, with headquarters at Quincy, Ill.

Pecos Valley.—Mr. C. M. Stansbury has been appointed Master Mechanic, with headquarters at Eddy, N. Mex., to succeed Mr. G. F. Miller.

Pittsburgh, Bessemer & Lake Erie.—Mr. H. T. Porter has been appointed Chief Engineer, with headquarters at Pittsburgh, Pa., succeeding Mr. Francis E. House, promoted.

San Francisco & San Joaquin.—Mr. W. B. Storey has been appointed Chief Engineer, with headquarters at San Francisco, Cal.

Salt Lake & Ogden.—Mr. W. T. Godfrey has been appointed Master Mechanic, with headquarters at Salt Lake City, Utah. He is to succeed Mr. John Hurst, deceased.

Southern Indiana.—Mr. Alexander Shields has been appointed Master Mechanic, with headquarters at Bedford, Ind.

Sandusky & Hocking.—Mr. F. P. Boatman has resigned as Master Mechanic.

Southern Pacific.—Gen. Thomas H. Hubbard, Second Vice-President of this company, was chosen First Vice-President, to fill the vacancy caused by the death of Charles F. Crocker. Mr. George Crocker was chosen Second Vice-President, to succeed Gen. Thomas H. Hubbard.

Texas Midland.—Mr. U. R. Smith has been appointed Master Mechanic, to succeed Mr. B. R. Hanson.

Wagner Palace Car Company.—Mr. J. A. Spoor, General Manager, has been chosen President of the new company formed by a consolidation of the Union Stock Yards and Transit Company and the Chicago, Hammond & Western Railroad.

Waynesburg & Washington.—Mr. Joseph Wood has been elected President.

AMERICAN ENGINEER CAR BUILDER AND RAILROAD JOURNAL.

FEBRUARY, 1898.

CONTENTS.

ILLUSTRATED ARTICLES:	Page	MISCELLANEOUS ARTICLES:	Page
Concord Shops—Boston & Maine Railroad, with Inset.....	37	Dangers in Annealing.....	45
Locomotives with Piston Valves—Norfolk & Western Railway	38	Baltimore & Ohio Presidents....	47
New Postal Cars—Chicago & Alton Railroad.....	43	Sanitation of Cars.....	52
A Rope Drive in a Railroad Shop.....	45	Wastefulness of Auxiliary Engines.....	53
70,000 Pound Coal Cars—N. P. Railway.....	46	Engineering Notes.....	57
Eight-Wheel Locomotives for Japan.....	48	Personals.....	59
Q & C Scott Boiler Feeder.....	48	Books and Pamphlets.....	60
80,000-Pound Coal Cars—C. & E. 1. Railroad.....	50	Pooling Locomotives and Locomotive Crews.....	63
Powerful Locomotives—Great Northern Railway.....	51	New 10-Wheel Locomotives—Northern Pacific Railway.....	65
Combination Electric Construction Car.....	52	The National Association of Manufacturers.....	67
The Black Diamond Truck.....	53	The Cleaning of Triplo Valves... ..	68
Braekin Pipe Wrench.....	67	Railway Signaling Club.....	68
Malleable Iron Brake Forks.....	62	Subjects for M. C. B. Conventions.....	69
Tonnage Rating.....	66	Track Improvements on Great Northern Railway.....	69
MISCELLANEOUS ARTICLES:		Pennsylvania Limited.....	69
Terms of Steam Engine Efficiency.....	11	Equipment and Manufacturing.....	70
English Opinion on American Fast Trains.....	41	EDITORIALS:	
Continuous Rope Driving.....	43	The Value of New Machine Tools.....	54
Compound Locomotives.....	44	Duration of Locomotive Boiler Tests.....	54
Yarrow on American Machinery	44	Pooling Locomotives.....	54
		Height of Drawbars.....	55
		Brake Shoe Testing Machine ..	55
		The Advantage of Steel Cars... ..	55
		The Atlantic City Flyer.....	57

ANNOUNCEMENT.

A series of articles on the Construction of a Modern Locomotive, by a motive power officer of one of the lead ing railroads of this country, will commence in our March number, and will treat the subject in a practical manner from the ordering of the material to the testing of the finished locomotive. This will be a valuable record, based upon a wide practical experience, and as only a limited number of extra copies will be printed, you are urged to subscribe before the publication of the March issue.

CONCORD SHOPS—BOSTON & MAINE RAILROAD.

[WITH AN INSET.]

The tendency in all manufacturing enterprises is toward consolidation of work and of management for the purpose of economizing in operation. In railroad as well as in manufacturing shop practice this appears in the concentration of the work requiring special facilities at points where such facilities may best be provided and most satisfactorily operated. There is good business management in the plan that contemplates a few well equipped shops rather than a much larger number of less complete and less convenient plants, the number of which renders completeness too expensive for consideration. It may be considered significant that an important Western road, when installing a new hydraulic riveting plant, made it large enough to do the heavy boiler and firebox work for the locomotives of the entire road and upon this basis a large expenditure was warranted. There appears to be a strong tendency in this direction, though for several years very few large shops have been built.

The new shops of the Boston & Maine Railroad at Concord, N. H., are particularly interesting for these and for several other reasons. The buildings, except the storehouse and offices, are all of one-story. They are arranged with a view of convenience in handling material and of furnishing light to the workmen; the buildings are separated as much as consistent with convenience for the purpose of reducing the fire risks, and provisions are made for the future extension of

every building. The most noteworthy feature, however, is the concentration of the steam plant into one building and the distribution of power by electricity. This part of the work will be taken up in detail later in connection with the power house and machine shops and the cranes for handling the locomotive work. The general plan and sections of some of the buildings are illustrated by means of the supplement accompanying this issue. Mr. Henry Bartlett, superintendent of motive power of the road, kindly furnished the drawings and the information given in this description, which is published simultaneously in the "American Engineer" and the "Railroad Gazette" by special arrangement.

The shops are situated about a half mile south of the station at Concord, occupying a level plot of 26 acres extending along the west side of the main tracks. There are three main tracks at this point and a fourth gives access to the yard at Concord without the danger of delay by the occupation of the main tracks. The repair work of the Concord, the White Mountains, the Worcester, Nashua & Portsmouth and that of a part of the Southern divisions will be done here. The number of locomotives cared for will be about 300. The capacity of the car shops is about 400 freight cars and 50 passenger cars per month. The buildings alone occupy 4.63 acres of ground.

As shown in the large general plan of the grounds the tracks are arranged to give access to the shop yard at the centre and at each end and, by means of switch connections, the whole yard is accessible for locomotives. As stated, the buildings, with the exception of the store house, are all of one story—with the exception of the lumber shed they are all of brick. The roofs of the paint shop, the lumber shed, the car repair shops and the oil storehouse are all of gravel, while those of the other buildings are of sheet steel, with standing seams. The buildings are all provided with ends that may be removed, for the purpose of easy extension, when this becomes necessary. It will be noted that the location of the buildings provides for extension in length in either direction. This is an important matter to which special attention is directed.

The locomotive shop is at the north end of the plant, the main portion of the building being 305 by 130 feet, to which an extension 105 by 70 feet is added for the boiler and tank shop. This arrangement permits of running the locomotive cranes from the main locomotive shop directly into the boiler and tank shop, the advantage of which is at once apparent. The erecting shop has three longitudinal tracks, the central one of which runs through the building and through the boiler shop as well. Upon this track the engines will be dismantled, and the two 30-ton Sellers traversing cranes will take them to the work tracks on either side of the central track. All three tracks are provided with pits for work under the engines. The machine shops are in the wings of the building, and are therefore near the work. This building will be illustrated later. It should be stated that the three longitudinal tracks offer the advantages of avoiding the expense and trouble of operating a transfer table as well as saving the space occupied by the pit, which would be required for the transverse track arrangement; also with transverse tracks one very heavy crane would be required for raising locomotives, and it could not be so conveniently used for light work as are the two lighter cranes of the longitudinal track plan. With two cranes available for work in different parts of the building, when not required for handling engines or boilers, the general work of the shop may be facilitated. The crane service of such a plant is an exceedingly important matter, as it affects the cost of all of the heavy work and much of the lighter work; in fact, it is believed that more may be saved by installing efficient crane machinery than most people imagine. It is interesting to observe the contrast between most railroad shops and contract building establishments in this particular.

The wash building, near the locomotive shop, is 62 feet by 26 feet in size, and accommodates 150 men at once. This building is for the men in the locomotive and blacksmith shops, and is so placed as to be conveniently in the path from these shops to

the gate of the grounds. The north end of this building contains tanks for removing the grease from the running gear of the locomotives, a brick partition separating the parts of the building. An attendant looks after the sanitary and mechanical work of the building. West of the wash house is the lumber shed, a frame building, 300 by 40 feet, with a track on each side. This building is removed as far as possible from the other buildings to reduce the fire risk. It has a storage capacity for about 500,000 feet of lumber.

The store house is a two-story building 100 feet by 40 feet, and is accessible from two tracks, and also from a roadway for teams. The lower floor, as shown in the plan, has three platforms, one for unloading from teams and two for unloading from freight cars. A receiving and shipping room is provided at the north end, adjoining which is the store room for heavy material. A counter separates the store room from the vestibule at the south end, and the office for the storekeeper is in one corner of the building. The racks for the stores are adjustable, and like the rest of the interior of the building are of hard pine, with natural finish. In the upper story are the offices of the master mechanic and of the car department. At the north end of this floor is a large storage room for light stores, with independent stairs to the lower store room.

The blacksmith shop is opposite the store house. It is 100 by 60 feet, and has ten double forges and one large forge. There are four power hammers, two Bement and Miles steam hammers, one 1,200 pounds and the other 1,800 pounds, one Dupont belted hammer of 250 pounds and one Hotchkiss steam hammer of about 500 pounds. A bolt header, power shear and drill press were also located in this building. A 15-horse power Westinghouse motor mounted on the roof trusses drives the blower and the exhauster and a 20 horse power motor on the ground drives the other machinery.

The next group of buildings are the dry house, the planing mill, boiler and power house (combined in one building) and the small shops. The dry house is 75 by 25 feet, and is near the planing mill. Its floor is of old rails, and the steam piping is contained in an excavation about three feet deep below the floor. In this 8,000 feet of 1 1/2 inch piping is placed and divided into eight sections in order to permit of regulating the amount of heat. A section of this building illustrates its arrangement. The planing mill and power house join at their ends. The walls are of brick, and the roof trusses of the power house are of iron, while those of the mill are of timber. The mill is 300 by 60 feet and the power and boiler house is 111 by 65 feet. All of the engines, dynamos and boilers of the plant are concentrated here, and power is distributed to motors in the shops and to the transfer table. The whole plant is also heated and lighted from this point, the system being sufficiently interesting to warrant taking it up in detail in a future issue.

The cabinet, pattern, buffing, tin and pipe shops are all under one roof in a building 200 by 40 feet, to which power is carried to drive a 5 horse-power Westinghouse motor. South of these buildings is a hand transfer table for light service for the car shops and the planing mill.

The freight and passenger repair shops are in one building, 323 by 170 feet, divided in the center by a fire wall. The freight-car work is done at the west end where thirty-two cars may be repaired at once. The passenger-car repair shop accommodates sixteen cars. These shops are well lighted and ventilated.

The transfer table is located south of the car repair shops, and is sufficiently removed from the buildings on each side to allow cars to stand between the pit and the buildings, the space provided being 82 feet on each side. The pit is 280 by 70 feet, and the table connects with the tracks leading directly from the locomotive shop. The table, which operates from an overhead trolley, was furnished by the Industrial Works of Bay City, Mich. It is provided with winches, and the machinery is housed.

South of the transfer table is the paint shop, which is 238

by 165 feet, and has space for sixteen passenger cars and four locomotives. At the east end of this building are the varnish and upholstery rooms, each 81 by 36 feet, divided from the main shop by a brick wall. The last building at the south end of the plant is the paint and oil store house, a building 50 by 25 feet, with a cellar and arched floor.

The buildings are arranged with a view of avoiding unnecessary transportation of material, and those containing the machinery are so planned as to permit all work of one kind to be kept together. The electrical distribution will be described later; also the steam distribution system. The steam, water and air pipes are carried through closed trenches to the various building, and are located as shown in the general plan of the shops and grounds. The drainage system is very complete, and is connected with the city sewer, a branch of which passes through the grounds. The locations of the drains are also indicated on the plan. The compressed air piping is carried through the locomotive and car shops and yards, the power being furnished by an 8 by 12 inch, duplex compressor furnished by the Rand Drill Company. The waterworks are connected with the city mains and there are two lines of water pipes—one for fire service, carrying 110 pounds per square inch and the other for shop use, carrying 90 pounds.

The entire plant is heated by the fan system, furnished by the Boston Blower Company, of Boston, Mass., on a guarantee to maintain the following temperatures in zero weather: Car repair shops, 65 degrees; planing mill, 65 degrees; cabinet and pattern shops, 70 degrees; small shops, 65 degrees; locomotive and boiler shops 65 degrees; paint and varnish shops, 75 degrees; paint and oil store, 65 degrees. The blower and exhauster in the blacksmith shop and the smoke fan for artificial draft in the power house were furnished by the same company.

The plans, specifications and details of the arrangement of the mechanical features were drawn up by the motive power and car departments of the road, and the plans and specifications of the buildings were prepared in the Chief Engineer's department. The contractors were as follows: Buildings, Messrs. Mead, Mason & Co., of Boston; iron work, the New England Structural Works, Boston; shafting, Somersworth Machine Co., Boston; electric machinery, the Westinghouse Electric and Manufacturing Company, Pittsburgh; steam and air piping, Coffin & Co., Boston; heating, the Boston Blower Company, Boston; transfer table, Industrial Works, Bay City, Mich.; cranes in locomotive shop, William Sellers & Co., Philadelphia; steam pipe covering, the Keasbey & Mattison Company, Ambler, Pa.; boilers, Edward Kendall, Boston; engines, the Westinghouse, the Fitchburg Steam Engine Companies, and Messrs. Armington & Sims.

Mr. C. H. Wiggin, master mechanic, is in charge of the locomotive department, and Mr. J. T. Gordon of the car department.

LOCOMOTIVE WITH PISTON VALVES—NORFOLK & WESTERN RAILWAY.

It has been quite common for simple or single expansion engines to be changed into compounds to the improvement of the engines, and it is not common to see compounds changed into single expansion engines with good results; but Mr. G. R. Henderson, Mechanical Engineer of the Norfolk & Western Railway, has kindly furnished us with very interesting information concerning such a change on a locomotive on that road which has been attended with very interesting and valuable results, which tend to confirm three opinions, viz.: That simple engines may be vastly improved without resorting to any questionable practices or any complications; that compound engines may probably be improved in proportion by very nearly the same process, and that a piston valve is "a good thing."

The engine was originally built as a compound, but, partly for experimental purposes, it was decided to replace broken cylinders with simple cylinders, fitted with piston valves. The general features of the engine in its present condition are as follows:

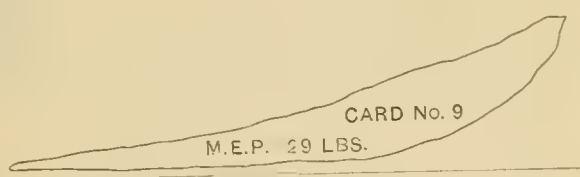
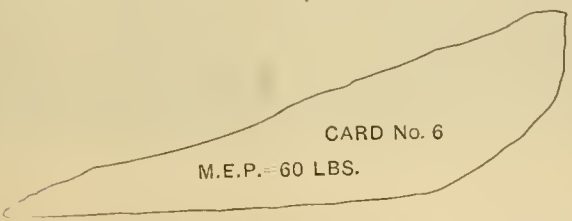
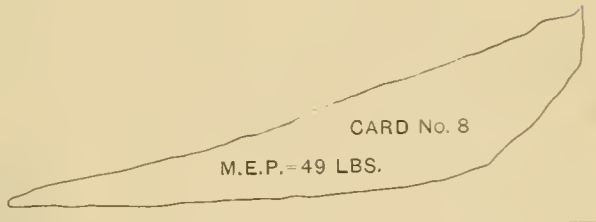
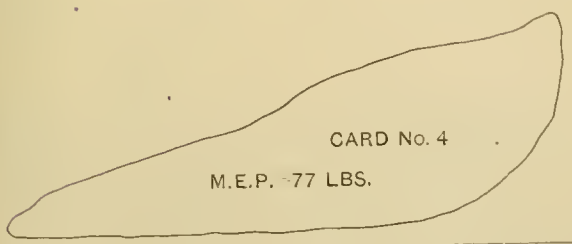
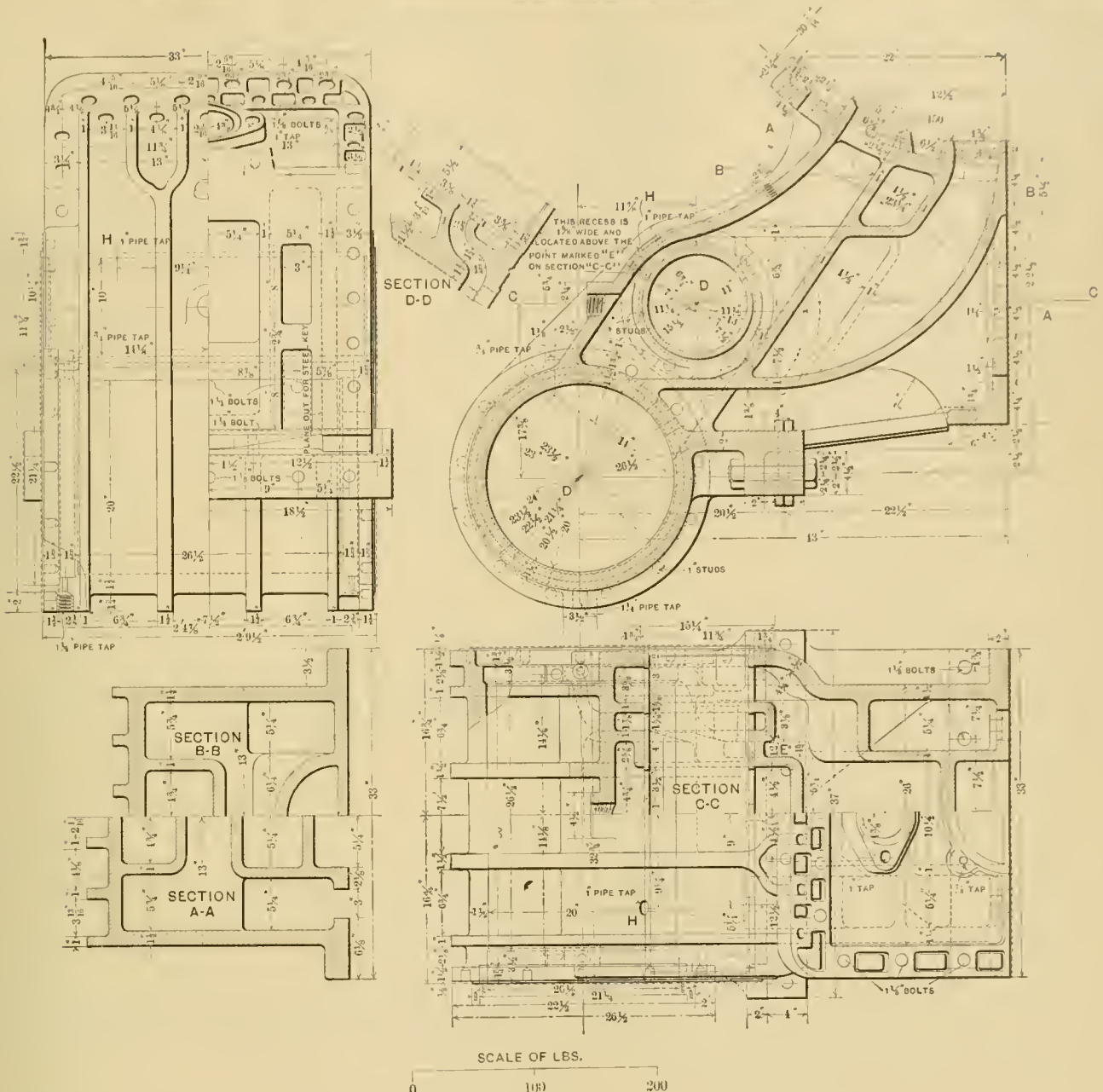

Card No. 1.—Boiler pressure 172 pounds; throttle $\frac{3}{8}$; cut-off, 7 inches; speed, 35 miles per hour.
 Card No. 6.—Boiler pressure, 178 pounds; throttle full; cut-off, 8 inches; speed, 56 miles per hour.
 Card No. 8.—Boiler pressure, 175 pounds; throttle full; cut-off, 8 inches; speed, 68 miles per hour.
 Card No. 9.—Boiler pressure, 135 pounds; throttle, $\frac{1}{4}$; cut-off, 5 inches; speed, 73 miles per hour.

Locomotive with Piston Valves—Norfolk & Western Railway.

Type of engine.....	10 wheel
Diameter of cylinders.....	20 inches
Stroke of cylinders.....	24 inches
Diameter of driving wheels.....	68 inches
Boiler pressure.....	180 pounds
Grate area.....	29 square feet
Heating surface.....	1,967 square feet
Adhesive weight.....	102,300 pounds
Total weight of engine and tender.....	220,200 pounds

The general appearance of engine and tender is shown by the photograph, and the appearance of the cylinders with piston valves is neat and attractive.

Some features of the detail design of the cylinders and valves may be specially mentioned. The drawings show that the piston valve is located nearly on a straight line drawn from the center of the cylinder to the center of the steam pipe connection, and the section *DD* shows that the ports from the valve to the cylinder are very short and direct; the steam enters the saddle and passes in a straight line to the center of the valve chamber, from which it is distributed on each side by the valve, the exhaust ports being on the outside edge of the cylinder at the front and back. In this way the steam passages are well protected and surrounded on the front and back ends by the exhaust passages, which make a sort of steam-jacket, and the ribs on the outer surface support a lagging, which further protects the steam passage from direct radiation. Another advantage of this arrangement is that the valve-stem stuffing box has practically no pressure upon it, and there should be little trouble in keeping the packing tight.

The valve itself has three packing rings, and, of course, in this case the outside lap is really measured on the inside of the valve, and amounts to $1\frac{1}{8}$ inches. The valve has $\frac{1}{8}$ inch inside, or really outside, clearance, and in setting no lead was given in full gear.

One serious objection to piston valves has been the difficulty which attended setting them properly. With the usual construction of slide valve and steam-chest, it is a very easy matter to get the exact position of the valve relative to the ports by leaving the lid off; but ordinarily with a piston valve the only way these points can be settled is by measurements, carefully taken, from the valve and bushing before they are put in place. To overcome this difficulty two holes will be seen to be provided, marked *H H*, and these are closed with one-inch pipe plugs. These holes open directly into the steam port, and opposite the cutoff edge of the openings in the bushing, so that by merely removing these pipe plugs and holding a candle or mirror in the proper position, the points of opening and cutoff can be inspected without removing either of the cylinder heads or making any close measurements.

This form of cylinder is an unusually strong one. Cylinders often break in a line directly over the front end of the frames, but from the shape which this form of cylinder assumes it would seem almost impossible for it to break at that point.

Some indicator diagrams recently taken from this engine in passenger service are also shown. The run was its regular schedule between Roanoke and Norfolk, and the load which it hauled consisted of six cars, weighing about 350,000 pounds, which, together with the weight of engine and tender, made a total of 285 tons. Card No. 1 was taken on a 66-foot grade, as the engine was accelerating the train from a stop. Card No. 4 was taken as the train was being hauled up a 61-foot grade at a speed of 35 miles per hour. Card No. 9 was taken running on a slight down

grade. Other cards not reproduced were taken on portions of road which were practically level, or on which the grades were slight or short. We think it is interesting to note the full outline of the cards, which is due, undoubtedly, to the piston valve, which gives a very large opening for the admission of steam, and also to the fact that the back pressure is very fair, and the compression about what would be desired. The cards at high speed seem to be exceptionally able bodied. They are indeed "fat and jolly." In two cases the indicated horse power exceeded 1,100.

During the month of October, 1897, this engine (No. 77) had the same run as one of the compound engines (No. 75) from which type it had been converted, and a comparison has been made of

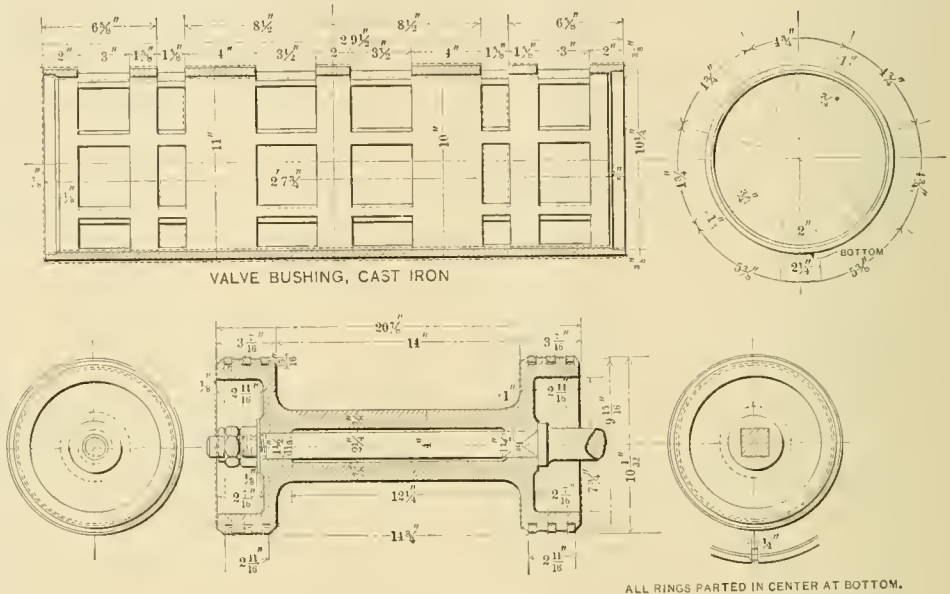

Sections of Valves and Bushing.

the performance during this time. Both engines were hauling trains No. 3 and 4, between Norfolk and Roanoke, during this period. The record shows as follows:

Eng.	No. pass. car mls.	Mls. light.	Coal in lbs.	Lbs. coal per car mi.
75 (comp.)	35,219	115	364,000	10.24
77 (simple)	35,430	100	367,500	10.28

From the above, it will be seen that engine 77 used about four-tenths of one per cent. more coal than engine 75 in identically the same service, and this small amount could easily be ac-

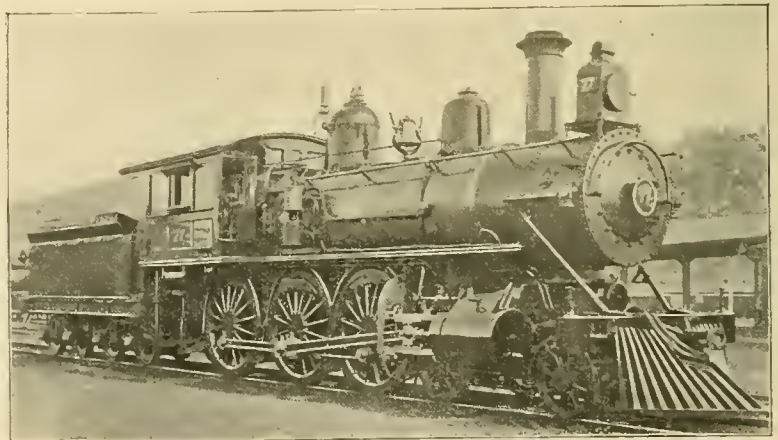

Locomotive with Piston Valves.—N. & W. Rv.

counted for by variations in quality of fuel, or other minor causes. As compound engines usually show an economy of from 15 to 20 per cent. in fuel over simple engines, we think that this is a very good showing for a simple engine, and that a large

portion of it is probably brought about by the directness of the steam passages, the small amount of clearance and the fact that the steam ports and passages are so well protected against external radiation.

TERMS OF STEAM ENGINE EFFICIENCY.

A committee of the British Institution of Civil Engineers, appointed a year ago or more, says "Science," have reported the following recommendations on steam engine efficiency, and they have been adopted by the Council:

(1) That the statement of the economy of a steam-engine in terms of pounds of feed water per indicated horse power per hour is undesirable.

(2) That for all purposes except those of a scientific nature it is desirable to state the economy of a steam-engine in terms of the thermal units required per indicated horse power (or per minute), and that if possible the thermal units required per brake horse power should also be given.

(3) That for scientific purposes the thermal units that would be required by a perfect steam-engine working under the same conditions as the actual engine should also be stated.

The proposed method of statement is applicable to engines using superheated steam as well as to those using saturated steam, and the objection to the use of pounds of feed water, which contain more or less thermal units according to conditions, is obviated, while there is no more practical difficulty in obtaining the thermal units per indicated horse power per hour than there is in arriving at the pounds of feed water.

For scientific purposes the difference in the thermal units per indicated horse power required by the perfect steam-engine and by the actual engine shows the loss due to imperfections in the actual engine.

A further great advantage of the proposal is that the ambiguous term "efficiency" is not required.

AN ENGLISH OPINION ON AMERICAN FAST TRAINS AND LOCOMOTIVES.

In a recent communication to "The Engineer" of London, Mr. W. M. Ackworth expressed his opinion of American trains and locomotives in part, as follows:

"Having lately returned from a visit to the United States, during which I traveled upward of 1,000 miles on the engines of their crack expresses, I should like to say a few words on the question of American railway speeds. * * * First, as to the 'Atlantic City Flyer.' You state categorically that you believe the record you have published to be fallacious. Now I am quite aware that American railway men have, in some instances, allowed records to go out, apparently with their endorsement, which yet could not stand investigation; but I have no doubt whatever that the Atlantic City performances have, as a whole, been accurately reported, though doubtless the accuracy of the intermediate times is not exactly what we might have looked for. For not only have the Philadelphia & Reading officials and the Baldwin Locomotive Company made themselves responsible for them, and this, not for one month's running only, but for two months; but further, Mr. Voorhees, first vice-president of the Reading, has publicly complimented the 'engineer' of the train on his record performance. Now, considering that probably at least 10,000 passengers, first and last, traveled by the train, and that its origin was due to a disagreement with the competing Pennsylvania Railroad, is it reasonable to suppose that the record, if inaccurate, would have remained entirely unchallenged, as to the best of my belief it has, in fact, done? Further, the same company has been running for some time past, and is still running, a train booked to cover the 55½ miles in 55 minutes, and this train is not only heavier, but uses ordinary instead of picked coal. And that this train, the 4 p. m., ex Philadelphia, keeps time with consummate ease I can testify from personal experience.

"For, having gone to Philadelphia on September 9, in order to travel on the 'Flyer,' and having found to my disappointment that it had ceased to run two or three days previously, I went down on the date mentioned by the 4 p. m. Here are the times taken by me with a split-second stop-watch for every mile from start to stop. I may say that, for convenience of record, I wrote down the nearest whole second, though my

watch registered fifths of seconds. But the total time, from the moment the wheels began to turn till they ceased to move, is absolutely exact. Further, in some cases, owing to passing trains or some other accidental causes, I missed a post, and in those cases I have bracketed that mile and the next together:

	Miles.	Seconds.	Miles.	Seconds.	Miles.	Seconds.
1	175	20	49	39	50
2	92	21	51	40	51
3	71	22	50	41	52
4	64	23	53	42	51
5	65	24	50	43	54
6	119	25	53	41	195
7	76	26	53	45	51
8	57	27	53	46	51
9	53	28	51	47	51
10	29	18	48	48	52
11	105	30	48	49	52
12	50	31	50	50	53
13	52	32	49	51	50
14	54	33	48	52	48
15	60	34	51	53	50
16	59	35	51	54	53
17	115	36	50	55	204
18	37	50	50	stop	1
19	52	38	48		

Total time, 3,210 seconds = 53½ minutes for 55½ miles.

"It will be seen that from the fifth to the fifty-fourth mile posts the speed only varied between 60 and 75 miles an hour. It will be noted also that the last dozen miles or so, which are slightly down hill, are slower than the middle of the run—proof sufficient surely that the engine was running within herself, at least when coupled with the fact that we were on arrival two minutes in front of time. * * *

"A week or two later I traveled on the Empire State Express of the New York Central. The load was 178 tons—English—behind the tender. From Syracuse to Rochester, 80½ miles, we ran in 80 minutes; from Rochester to Buffalo, 68 miles, we took 72 minutes, spite of a dead slow over a bridge that was being sledged, and 3 miles at half-speed through the streets of Buffalo. Here is a record of the seconds taken for 18 consecutive miles with this train—51, 49, 48, 48, 47, 46, 46, 47, 47, 46, 46, 92—two miles—46, 46, 48, 45, 47.

"Here is another record, this time from the 'Black Diamond' Express of the Lehigh Valley Company. Load 165 tons—English—behind the tender; Geneva to Sayre, 73½ miles in 74 minutes; Easton to Jersey City, 76 miles, in 79 minutes, with two regular station stops at South Plainfield and Newark, included. And these, be it observed, are not special racing trains, but ordinary every-day expresses which run all the year round, and, what is more, keep time like a clock.

"Whether the best English expresses ought to be as fast as the best American is a question we need not discuss. That, in fact, they are not as fast seems to me proved to demonstration. It is, therefore, I submit, not reasonable to say that American records are fallacious, because there are no English records to match them. * * *

"But, assuming American engines to make faster times than ours, 'Why,' you ask, 'do they do it?' May I suggest, from a layman's point of view, some portion, at least, of the answer? That the American locomotive is in some respects superior as a vehicle I know, from the very practical test that it is possible, on an American engine, to write legible notes when traveling at 70 miles an hour and upward. On an English engine, so far as my experience goes, this is not possible. How much of the difference is due to the higher centre of gravity in America, how much to the greater flexibility given by the bar frames and equalizing levers, or, again, to the superior elasticity of their chairless permanent way, I will not attempt to say. 'Oua' motor, the American locomotive has the advantage that its much greater adhesive weight and tractive force enable it to accelerate its train much quicker. In other words, for a given weight to be hauled at a given speed, American practice provides a much greater reserve of power than English. Further, there is no doubt that American engines, extravagant fuel consumers though they doubtless are, can, with their huge grates, large heating surface and sharp draft, make steam more freely than ours. This must mean that they can fill and empty their cylinders without running short of steam faster than English engines could do.

"As far as I have seen, the maximum American and the maximum English speeds are very much the same. But in England 75 miles an hour and upward implies running down a bank, with steam quite or all but shut off; in America that speed is made with steam on—in other words, on a level or something very like it. Ten years ago Mr. Rous-Marten wrote that the ideal English locomotive would haul 150 tons on the level at 60 miles an hour. That ideal had hardly been attained then it has been attained and passed now. But I do not think it will be claimed for any locomotive at present running in this country that it can maintain 70 miles an hour with 200 tons behind it on a dead level, and there are, I believe, a good many different types of engines which can do this in the States."

NEW POSTAL CARS, CHICAGO & ALTON RAILROAD.

The annual reports of the General Superintendent of the Railway Mail Service show that marked and effective improvements have been made during the past few years, as regards the safety and convenience of postal cars, with the general features of which our readers are familiar. The location of postal cars at the head of trains renders them specially liable to damage in case of wrecks, against which all possible precautions are taken to render them safe as well as comfortable for the employees of the department. Pintsch gas equipment is regarded by the department as being not only the best system as regards illumination, but also for the safety of the clerks and the mails in case of accidents. In new cars of this type, Pintsch gas, steam heat, vestibules and other safety appliances are considered necessary and in the design under consideration these features are included.

Two of these cars have been built by the Pullman Palace Car Company, for use on the Chicago & Alton Railroad. They are run over this road from Chicago to St. Louis and are now in service. Through the courtesy of Mr. Lewis L. Troy, Superintendent of the Railway Mail Service at Chicago, we have received the drawings and specifications of these cars. The length, inside in the clear is 60 feet, the length over all, including the horn timbers, is 69 feet 10¾ inches. The length over the main end sills is 60 feet 8¾ inches and the length from center to center of trucks is 44 feet 11½ inches. The width of the car in the clear inside is 9 feet 3¾ inches, the width over side sills is 10 feet ½ inch and the height of the car from the under face of sill to top of plate is 7 feet 4 inches.

The drawings show a half side elevation and half longitudinal section of the framing, a sectional plan view and a plan of the underframe. From an examination of these drawings it will be seen that the car has no platforms, but closed vestibules are provided at each end. At the right hand end, the wardrobe, lockers and washbowl are placed, while at the opposite end are the toilet room and Baker heater. Both of the vestibules, as well as the body of the car, are lighted with Pintsch lamps, of which there are seven, five cluster center lamps and two drop bracket lamps. Each car carries three gas holders, fitted with the necessary attachments, as furnished by the Safety Car Heating & Lighting Company. The Baker heater, enclosed in a zinc-sheathed stove room, has a two-inch coil with four pipes covered with cast-iron fenders running around the car. The coal box is underneath the heater and is extended back of the heater by a chute to the roof.

There are six longitudinal sills of yellow pine, of which the two side sills are 6½ by 8 inches by 67 feet in length, extending to the 6 by 8 inch vestibule end sills. The other sills are placed close together and are 5½ by 6¾ inches by 60 feet, ending at the vestibules. The drawings clearly indicate other features of the underframe. The cars are provided with Blackstone horn timbers, which are 4 by 8 inches by 12 feet of oak, and, like the bumper arms, are plated with ½ by 6 inch iron and bolted every 8 inches with ½-inch carriage bolts. The arrangement of these timbers is clearly indicated in the drawing. There are four needle beams, 4½ by 6½ inches by 10 feet, which are trussed with ¾-inch rods, having struts 12 inches each on side of the center of the car. The flooring is in three courses of yellow pine and the lining under the sills is of ¾ by 5 inch yellow pine tongued and grooved. There are four side doors, each provided with mail catcher castings. The outside sheathing is of yellow poplar, the ceiling being of the same material matched and beaded. The letter cases, 12 in number and 10 tiers in height, including the necessary drawers and tables, are of ash. Overhead paper boxes are provided, under which are the Harrison racks for mail sacks. The cars have the Westinghouse Air-Brake with quick action triple valve.

The trucks have six wheels each, of the standard 38-inch

steel tired Page type, with National Hollow Brake Beams. The axles are of hammered iron, the oil boxes being of the Pullman pattern with Fletcher pressed steel lids. The body springs are double elliptic and coiled springs are placed at the journals, all of the springs being furnished by The A. French Spring Company. The drawings were prepared by Mr. H. Monkhouse, Superintendent of Machinery of the Chicago & Alton Railroad.

CONTINUOUS ROPE DRIVING.

Spencer Miller, member of the American Society of C. E., read before that society on December 15, a paper on the subject "A Problem in Continuous Rope Driving," in which he takes up and reviews the method at present employed in driving with manilla rope, where the driving wheel is larger than the driven, which is usually the case in driving from an engine to a jack shaft, or to a dynamo.

He first called attention to the fact that for efficiency in rope driving, it is necessary to use angular grooves for the rope to rest in, and takes 45 degrees as the best angle employed for such work. The friction in a rope over a pulley is multiplied two and one-half times by the use of this angle, assuming the low coefficient of friction of .12 the coefficient of resistance to slipping becomes .31 by the use of the 45-degree angle. He next demonstrates the value of the large arc of contact of the rope to the pulley, in order to get considerable driving force. When, however, the rope drive is as is usually installed, the larger wheel has very much the larger arc of contact, and the smaller wheel a very much smaller arc of contact.

In consequence of this the larger wheel has a much greater grip on the rope, and a great deal greater driving power. He shows, therefore, that nothing would be lost by widening the angle on the large pulley so that the resistance to slipping is equal in both wheels, and then goes on to demonstrate that not only is there no power lost, but that there is considerable gain in power. He cites an example of a rope drive which was a failure, and explains why it failed. The drive in question had a driver about three times the diameter of the driven, and the centers were quite short, so that the rope on the large pulley was in contact for only 143 degrees. Now with both of these wheels grooved to 45 degrees, and assuming that the rope should not be pulled in any point to a greater extent than 300 pounds, he shows that only about 53 H. P. can be obtained from the transmission, the tight ropes pulling at the rate of 300, 200, 133, 88 and 60 pounds, while by widening the angle of the large sheave to 72 degrees, leaving the small one 45 degrees, each rope gives a pull equal to 300 pounds, and the total power transmitted is 100, which is practically double. This claim might seem paradoxical, but it was nevertheless clearly demonstrated.

Mr. Miller then shows the advantage of using such a method of driving, by referring to a practical example of a drive which he designed some ten years ago, which has been running successfully, transmitting power in a planing mill. This drive transmitted 250 h. p., and was designed so as to use a 1¼ or 1½-inch rope, but in order to demonstrate the life of the rope, and the effect of the sudden tension of the load, he put on a ¾-inch common manilla rope, bought from a ship chandler, and this first rope lasted six years before it had to be replaced. Since that time, of course, larger rope has been used.

The paper gave a full scientific analysis of the strains on the rope from a theoretical standpoint, which agreed perfectly with the practical effect as shown in the transmissions of this character all over the country.

The compound winder which has been used for dynamo driving was shown to have defects in that the various strands of the rope do not pull alike, and while the compound winder has the advantage of being a safe method of transmitting power, he nevertheless proves that the compound winder would not be necessary at all, if his method of widening the angle of the large pulley was employed, reducing the friction on the large pulley equal to that of the small pulley. He also showed the disadvantage of using an angle of 60 degrees in place of 45, as it increased enormously, in some cases as high as 43 per cent., the journal friction engendered by the extra tension on the ropes required to transmit the requisite power. The theory of the paper was proved to be correct in many

ways, among others by the way in which the wooden sheaves, which were introduced in the early history of rope driving, wore on their grooves.

The paper was discussed by Prof. J. J. Flather, whose book on rope driving is without question the best text book ever written on the subject, by Samuel Webber, a leading authority on power transmission, by J. H. Hoadley, who has designed a large number of heavy rope drives, by H. W. Brinckerhoff and H. H. Supplee, all engineers associated with the subject, and all of them practically endorsed the theory advanced in the paper.

The use of the wider angle in the larger pulley was patented by Mr. Miller in 1891. Mr. Miller is the engineer in charge of the cableway department of the Lidgerwood Manufacturing Company, 95 Liberty street, New York City.

COMPOUND LOCOMOTIVES.*

By Prof. J. B. Johnson.

With reference to the future of the compound locomotive, my opinion is the compound locomotive has come to stay. It is peculiarly adapted to American conditions. With heavy loads at moderate speeds, it certainly does save from 15 to 20 per cent. of the fuel cost, as now built and operated, and this is a considerable item. On light train or on high speed service there is little saving of fuel, but where heavy passenger trains are to be hauled at the highest speeds, or when the speed is limited by the steaming capacity of the boiler, there is a considerable reduction in the water to be evaporated, and hence less difficulty in maintaining the pressure. While the cylinder repairs are increased, or perhaps doubled, the boiler repairs are greatly reduced, thus reducing the total expense, because the boiler repairs are the main item. Where the water is bad a reduction of the evaporation by 20 per cent. means a reduction of the incrustation by more than 20 per cent., because the incrustation rapidly increases as the impuri-

ty increases. We hesitate to venture into new and unfamiliar fields when we know we are to be held responsible for results. While a judicious conservatism is both laudable and even necessary in railroad management, I believe any further hesitation to acknowledge the merits of the compound locomotive in the class of traffic named above is a blind shutting of the eyes to demonstrated facts, which will soon be regarded as a sure mark of inefficiency in this department of railroad management.

I have had sent to me a sheet showing the saving in fuel on two divisions of the Chicago, Milwaukee and St. Paul Railway, as compared between their simple engines and compound engines of the same class, and they have a great many of each class.

This is a statement covering the entire year on two divisions of the road, the record simply showing the saving in coal, which is something of which a record can be kept, and apparently they have been doing equal work. The saving in coal is given per ton mile, and then the per cent. of saving, the average saving for one year; on the East La Crosse Division, 18.3; on the West La Crosse Division, 20.8 per cent. These figures, I think, speak louder than any man's opinion.

MR. YARROW ON AMERICAN MACHINERY.

Mr. A. F. Yarrow, the celebrated English marine engineer, who has been in this country for some time, is evidently impressed by the progress of American machinery builders and iron workers. According to an interview recently published in the New York "Sun" he said:

"American iron and steel workers are better paid than English, but they do far more than proportionately better work. They have superior diligence, application, and ingenuity, and take more interest in their work. It seems to be the rule for each man to do as much work as he can, while at home every one is afraid of injuring his fellow workman, and does no more than he has to. One noticeable thing in connection with this is the tending of automatic machines. I have seen one man in charge of several machines here, while at home it's against

CHICAGO, MILWAUKEE & ST. PAUL RAILWAY.

Comparative Coal Statement for Compound and Simple Engines, East and West La Crosse Division, for 12 Months Ending June 27, 1897.

Months.	Style of engines.	East La Crosse Division.				West La Crosse Division.			
		Pounds of coal per 100 tons hauled one mile.	Cost per ton per mile.	Per cent. saved by compound engine.	Amount saved had all engines been compound.	Pounds of coal per 100 tons hauled one mile.	Cost per ton per mile.	Per cent. saved by compound engine.	Amount saved had all engines been compound.
July, 1896.....	Compound.....	11.02	.000935	18.5	\$548.31	10.18	.000865	16.1	\$438.11
	Simple.....	13.52	.001150			12.14	.01032		
August, 1896.....	Compound.....	11.57	.000983	22.0	072.98	10.37	.000882	18.2	508.61
	Simple.....	14.12	.001201			12.26	.001012		
September, 1896.....	Compound.....	11.90	.000982	19.7	656.45	10.99	.000907	20.6	569.97
	Simple.....	14.25	.001117			13.24	.001082		
October, 1896.....	Compound.....	10.20	.000867	15.3	491.89	10.57	.000897	23.9	836.22
	Simple.....	11.76	.001000			13.10	.001114		
November, 1896.....	Compound.....	13.82	.001141	20.6	909.31	12.28	.001013	20.8	821.26
	Simple.....	16.68	.001376			14.83	.001224		
December, 1896.....	Compound.....	14.04	.001193	23.5	982.38	12.92	.001077	21.1	716.30
	Simple.....	17.33	.001473			15.34	.001304		
January, 1897.....	Compound.....	15.40	.001398	18.5	447.52	13.32	.001133	16.7	517.42
	Simple.....	18.25	.001551			15.54	.001321		
February, 1897.....	Compound.....	14.45	.001229	19.0	640.17	12.99	.001104	18.0	597.30
	Simple.....	17.19	.001461			15.32	.001302		
March, 1897.....	Compound.....	14.01	.001155	16.0	488.50	12.17	.001001	28.0	725.87
	Simple.....	16.24	.001340			15.54	.001282		
April, 1897.....	Compound.....	12.41	.001055	16.0	478.12	11.63	.000989	15.0	402.53
	Simple.....	14.36	.001221			13.34	.001131		
May, 1897.....	Compound.....	11.58	.000981	18.0	500.78	10.90	.000927	20.0	514.61
	Simple.....	13.62	.001158			13.06	.001110		
June, 1897.....	Compound.....	10.93	.000902	20.0	493.84	9.91	.000820	26.0	668.17
	Simple.....	13.09	.001180			12.55	.001035		
Average.....	Compound.....	12.65	.001064	18.3	\$7,353.18	11.50	.000968	20.8	\$7,316.40
	Simple.....	14.97	.001260			13.89	.001168		
Total.....									

ties accumulate by concentration at the end of the run. The compound locomotive has been largely abandoned in England because the loads are small and their speeds high; but wherever the work of the engine is very heavy and the speeds moderate, the compound locomotive is winning its way on its merits the world over. One American manufacturer has turned out over 800 of these improved locomotives, all since 1890, and now at the rate of 200 a year, and all large American railway systems which have heavy work and have given them a fair trial are rapidly approaching their exclusive use in this class of service. The inertia, not to say prejudice, of the average locomotive engineer is largely responsible for the slow adoption of this new improvement, but our master mechanics and superintendents of motive power are, I suspect, not alto-

gether blameless. We hesitate to venture into new and unfamiliar fields when we know we are to be held responsible for results. While a judicious conservatism is both laudable and even necessary in railroad management, I believe any further hesitation to acknowledge the merits of the compound locomotive in the class of traffic named above is a blind shutting of the eyes to demonstrated facts, which will soon be regarded as a sure mark of inefficiency in this department of railroad management.

The lowered prices of raw material in this country have put American engineers into direct competition with their English contemporaries, and I believe this competition will continue and grow keener. The materials, etc., for the Central Railway in London are being supplied by Americans, who are also shipping steel billets to England, boiler plates to Holland, and deck beams to Belgium. These are all centers of the various industries using those materials, and England formerly supplied them. I foresee that America will soon take the first place in the world unless England bestirs herself and

* From remarks made before the St. Louis Railway Club.

shakes off the attitude of indifference assumed thirty years ago, when she was at the head in engineering industries.

"During my visit here I have purchased a quantity of small machine tools which are superior to the English makes. With such tools the price is of small moment; the best is wanted, no matter what the cost, though prices here compare favorably with those at home."

A ROPE DRIVE IN A RAILROAD SHOP.

The distribution of power from a central point in order to avoid the expense of operating independent stationary boilers and engines is now engaging the attention of many mechanical engineers, and there is probably no more favorable field for operations of this kind than in railroad shops, where it is not unusual to find a comparatively large number of isolated steam boilers and engines operating in the various departments. There are several methods of power distribution possessing advantages according to the special conditions of location and operation, one of which, a rope drive was selected in the case under consideration.

Formerly the power used in the boiler shop of the Waukesha shops of the Wisconsin Central was furnished by a Westinghouse engine and an independent boiler, and as the main en-

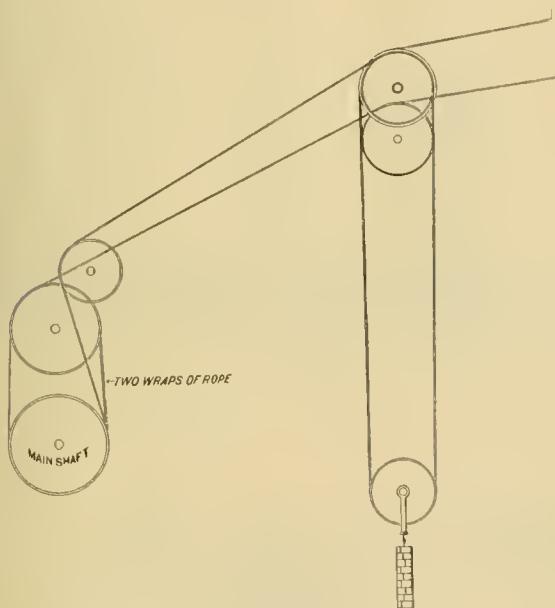

Rope Drive and Tension Attachment—Waukesha Shops' Wisconsin Central Lines.

gine in the locomotive shop had a reserve power not needed for that shop it was decided to connect it with the main shaft of the boiler shop by a rope drive, for which the location was favorable, and this permitted of doing away with the boiler shop steam plant. The main shafts in the two shops are parallel and about 200 feet apart horizontally, running in opposite directions. In order to carry the rope to the boiler shop it was necessary to lead from the main shaft in the machine shop up and over the locomotive traveling cranes and through the roof, across the space between the buildings to the boiler shop. A system of idlers carries the rope down into the boiler shop, and by crossing the lines the right direction of motion of the driven shaft is obtained.

Two wraps are used on the boiler shop sheave and a single wrap was sufficient on that of the main shop on account of the large diameter of the driving sheave. A single strand of special 1-inch manilla rope is used, the power transmitted being about 35 horse-power. The tension carriage is in the boiler shop, and is of the vertical type, providing automatic adjustment of the tension on the rope taking up the slack. This is placed in the boiler shop where it is under cover. The system is reported to be working satisfactorily, and the saving in the

cost of operating the boiler shop is considered as warranting the change.

The engraving illustrates the boiler shop end of the drive, and was prepared from a photograph received through the courtesy of Mr. James McNaughton, superintendent of motive power of the road.

DANGERS IN ANNEALING.*

F. A. Pratt, President The Pratt & Whitney Co.

We have most of our tap steel annealed at the place where it is made. We have had it done in this way for some years, with the exception of our long stay-bolt taps, which we have found to require more care in annealing than the steel-makers give them.

More steel is injured, and sometimes spoiled, by over-annealing than in any other way. Steel heated too hot in annealing will shrink badly when being hardened; besides, it takes the life out of it. It should never be heated above a low cherry-red, and it should be a lower heat than it is when being hardened. It should be heated slowly and given a uniform heat all over and through the piece.

This is it difficult to do in long bars and in an ordinary furnace. The best way to heat a piece of steel, either for annealing or hardening, is in red-hot, pure lead. By this method it is done uniformly and one can see the color all the time. We do some heating for annealing in this way and simply cover up the piece in sawdust, and let it cool there, and we get good results. All steel-makers know the injurious effects of over-heating steel and of over-annealing, but their customers are continually calling for softer steel and more thorough annealing. Until users are educated up to the idea of less annealing and to working harder steel, both will suffer, for the user will continually complain of poor steel.

Several years since we caught on to the fact that steel was injured by over-annealing, and that good screw-threads could not be cut in steel that was too soft; our men would rather take the steel bar direct from the rolls without any annealing than to take the risk of annealing. At present we get it from the makers in passable condition, but not as it should be, and unless the steel-makers find some way to heat the bars of a uniform heat, and at a low cherry red, we must either use it raw from the bar or anneal it ourselves. We find, also, that this soft annealing makes a much greater shrinkage and spoils the lead of the thread, and that from the bar without any annealing there is very little trouble in this respect.

When O. H. and Bessemer machine steel was first introduced, it was poorly made and hard to work. Users constantly urged the makers to make it softer, until when a maker could say his steel was as soft as iron, and not more than .10 or .15 of 1 per cent. carbon, he had the market. This company found out early that this soft machine steel was almost worthless. A shaft would bend easily in working, and if a lead-screw was to be cut it was not possible to get a smooth thread and a good finish.

Now we either make shafts and spindles of cast-steel of a high carbon, or of machine steel of about 50 per cent. carbon, without annealing. Our men kicked at first, but now they complain if it is soft, because they cannot cut a good thread and cannot keep it as true.

A report of L. L. Buck, chief engineer of the new East River Bridge, between New York City and Brooklyn, just issued shows that good progress is being made in the work upon the structure. The New York pier is now finished to a height of 2.54 feet above high water. The contract for the tower foundations on the Brooklyn side was let on June 30 last, and work begun on July 26. The south caisson was launched on October 19 and the north caisson on December 15. Mr. Buck estimates the cost of the work under way as follows:

New York tower foundations.....	\$370,000
New York anchorage.....	716,770
Brooklyn tower foundations.....	507,000
Brooklyn anchorage.....	721,850
Total	\$2,315,620

*Sparks from the Crescent Anvil.

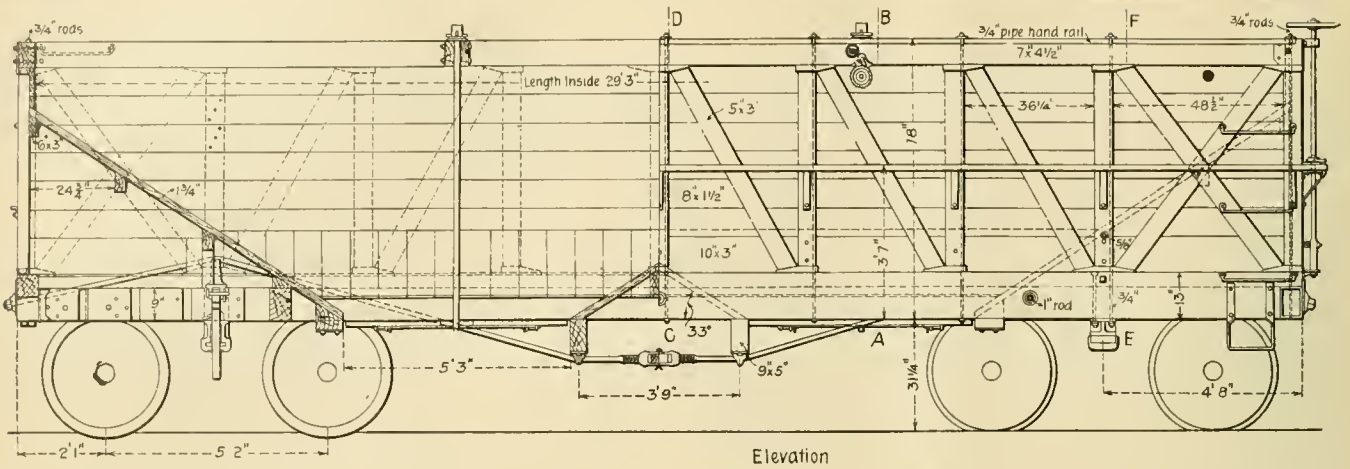

Elevation

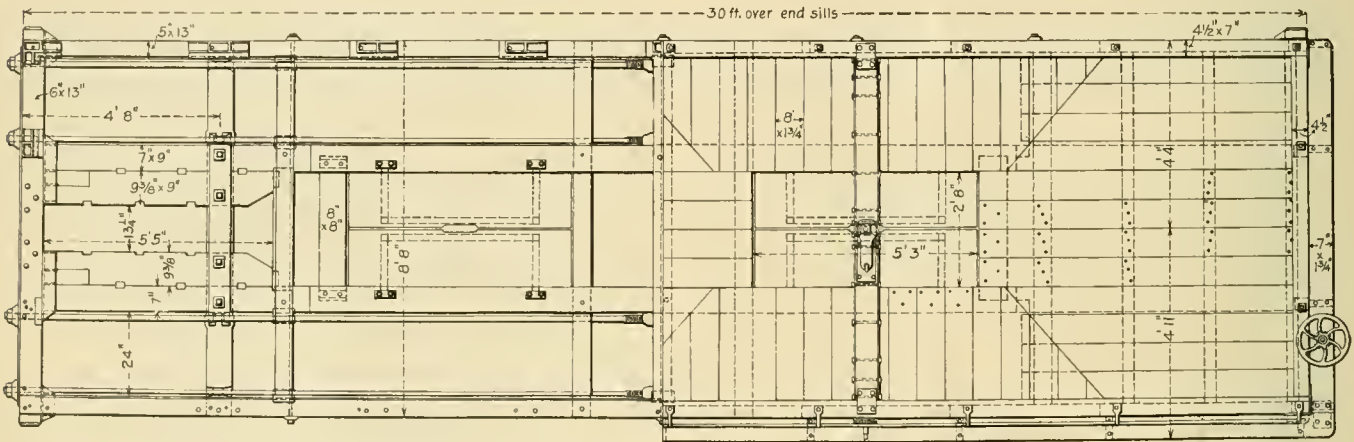

Half Plan of Bottom Framing.

Half Plan of Hopper Bottom.

70,000-Pound Coal Car—N. P. Railway.

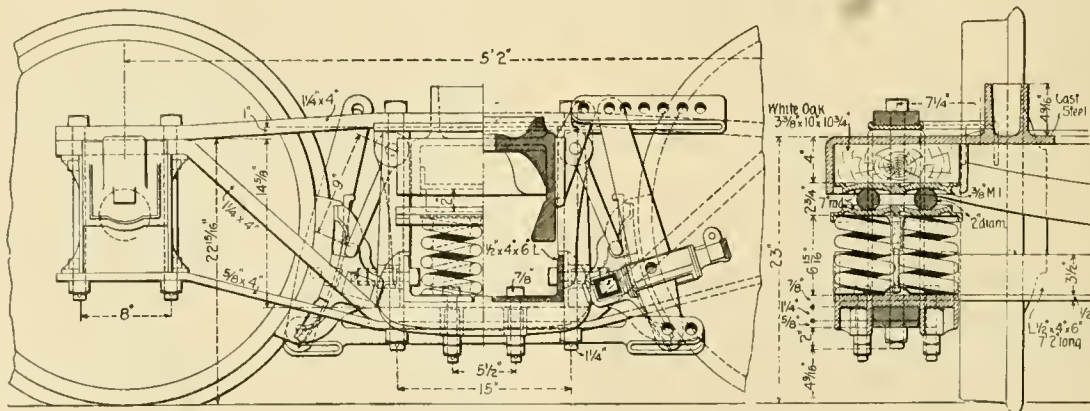

Sections and Partial Elevation of Truck.

70,000-POUND COAL CARS, NORTHERN PACIFIC RAILWAY.

Through the courtesy of Mr. E. M. Herr, Superintendent of Motive Power of the Northern Pacific Railway, we have received drawings of new hopper, gondola coal cars of 70,000 pounds capacity, weighing 28,400 pounds, which while not constituting radical departures in designing are interesting particularly because 1,070 cubic feet of space, when level full, is provided in a car 30 feet long over end sills and 6 feet 6 inches deep from the lower edge of the side sills to the top of the sides; this in a car of the twin hopper type is not usual. The length of the car inside is 29 feet 3 inches, the width over side sills is 8 feet 8 inches and the width inside 7 feet 11

inches. The hopper bottoms are carried down into and below the body of the car as far as possible and at the same time maintain an angle of 33 degrees for the sloping surfaces. This angle is used, except for the sides of the hoppers, which are at an angle of 30 degrees with the horizontal. The height of the bottom of the side sills above the rails is 31 1/4 inches, the wheels are 33 inches in diameter and the height over the brake wheel is 9 feet 7 5/8 inches above the rails. The illustrations show a sectional elevation, a half longitudinal section, a half plan of the car and half plan of the underframing, as well as transverse sections and a half end elevation, which show quite clearly the features of the design.

Attention is called to the 4 longitudinal sills, the side sills being 5 by 13 inches and the center sills 7 by 9 inches in

section. The end sills are 4½ by 7 inches, the needle beams are 5 by 9 inches and intermediate cross timbers, 5 by 9 inches, assist in carrying the hoppers. The door openings are 5 feet 3 inches by 2 feet 8 inches, the drop doors being covered

bolted to the body bolsters, which are of cast steel and are so made as to admit the center sills and draft timbers, and they extend beyond the bolsters to a 6 by 9-inch timber, which is let into the center sills. Four truss rods are used, having a diameter of 1¾ inches, so arranged as to lie close to the sills of the car. The ends of these rods are upset to a diameter of 1¾ inches. The sides of the car are tied together vertically by means of ¾-inch rods passing through the top rails and the side sills outside of the siding. The siding is braced by 5 by 3 inch verticals and diagonals, and the siding is composed of 8 by 1½ inch plank, except the lower course which supports the sides of the hoppers and is made of 10 by 3 inch material. The hoppers are of 8 by 1¾ inch material.

The engravings show the method of raising the hoppers and locking them, they also show the 7 by 1¾ inch running board, which extends along the ends and one side of the car for the purpose of furnishing a footing for the men operating the doors. A ¾-inch gas pipe hand rail extends along operating side.

The trucks are of the arch bar type, the truck bolsters being of cast steel, supported upon the springs by roller bearings. The top arch bar has a rise of 1 inch at its center, making the truck a low one. The wheels are of cast iron, 33 inches in diameter, weighing 600 pounds and the axles have 4½ by 8 inch journals with a wheel fit 5⅝ inches in diameter. The drawings of the trucks and of the truck bolster show clearly the manner of constructing these parts, and the roller bearings for the truck bolster. One hundred of these cars have been built at the Tacoma shops of the road, the cast steel body and truck bolsters for which were furnished by the American Steel Foundry Company, of St. Louis, Mo.

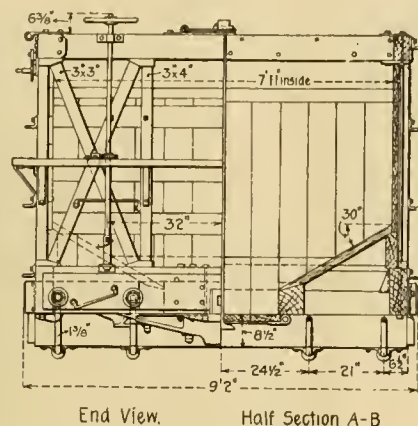

End View. Half Section A-B

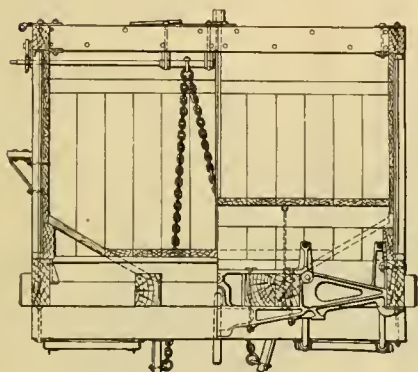

Half Section C-D Half Section E.F.
End View and Sections.

BALTIMORE & OHIO PRESIDENTS.

The recent annual meeting of the Baltimore & Ohio Railroad Company, which was its seventy-first, brings to mind the fact that the B. & O. has had ten presidents in 71 years, as follows:

Philip E. Thomas, Louis McLane, Thomas Swan, William G. Harrison, Chauncey Brooks, John W. Barrett, Robert Gar-

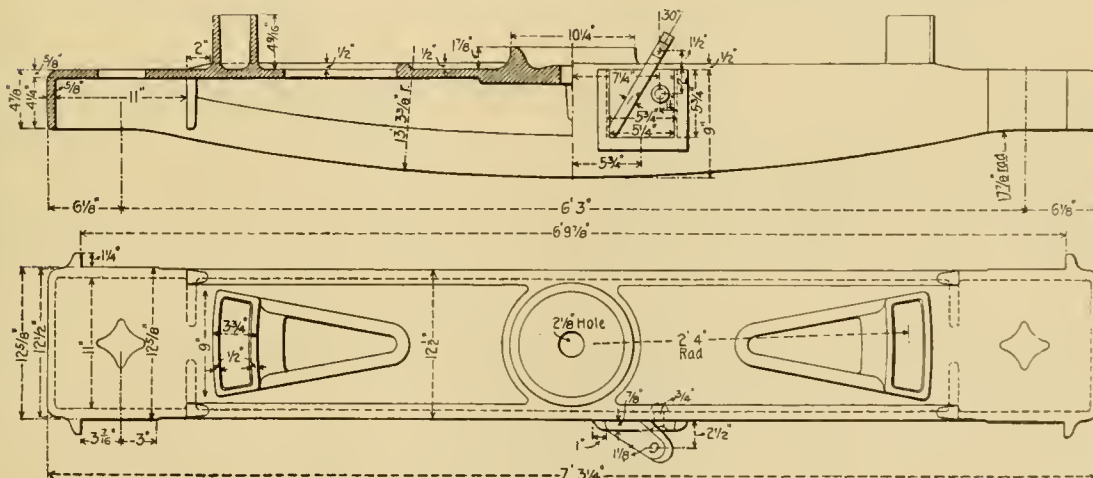

Cast Steel Truck Bolster.

with No. 10 steel plate. The V-shaped portion of the hoppers, at the center, rests upon the needle beams, which are spaced 3 feet 9 inches apart. Short pieces 8 by 8 inches in section extend across the center sills to support the inner edges of the long slopes of the hoppers at the door openings. The ends of the car under the hoppers are left open. The draft timbers are 9⅝ by 9 inches in section and are secured to the inner faces of the center sills. They are 5 feet 5 inches in length, are

ret. Samuel Spencer, Charles F. Mayer and John K. Cowen. The line was put in operation to Harper's Ferry in 1834, was built to Winchester, Va., in 1836, and to Strasburg in 1870. Westward it went to Cumberland in November, 1842, and on to Wheeling, W. Va., by January 1, 1893. The Parkersburg branch from Grafton to Parkersburg was opened May 1, 1857.

It is the only great railroad company that is being operated under its original name and charter.

EIGHT-WHEEL LOCOMOTIVES FOR JAPAN.

The accompanying engraving and table of dimensions show the chief interesting features of ten eight-wheel narrow gauge locomotives, recently built by the Schenectady Locomotive Works for the Imperial Railways of Japan. The tender is carried on three axles, there is no pilot and the headlight is very small, otherwise the general appearance of the design strongly resembles American practice. A separate dome is provided for safety valves and whistle. The valves are the American Balance type. Other features are noted in the following table:

General Dimensions.	
Gage.....	3 feet 6 inches
Fuel.....	Japanese bituminous coal
Weight in working order.....	73,600 pounds
Weight on drivers.....	52,350 pounds
Wheel base, driving.....	7 feet
Cylinders.	
Diameter of cylinders.....	16 inches
Stroke of piston.....	24 inches
Horizontal thickness of piston.....	5 1/4 inches
Diameter of piston rod.....	2 1/2 inches
Kind of piston packing.....	Cast-iron rings
Kind of piston rod packing.....	Jerome metallic
Steam ports.....	14 inches by 1 1/4 inches
Exhaust ports.....	14 inches by 2 1/2 inches
Bridges ports.....	1 inch
Valves.	
Kind of slide valves.....	American balanced
Greatest travel of slide valves.....	5 1/2 inches
Outside lap of slide valves.....	3/8 inch
Inside lap of slide valves.....	Line and line
Lead of valves in full gear.....	Line and line
Kind of valve stem packing.....	Jerome metallic

Grate, style.....	Rocking, with drop plate
Ash pan, style.....	Sectional, dampers, front only
Exhaust pipes.....	Single high
Exhaust nozzles.....	3 3/4 inches, 4 inches, 4 1/4 inches diameter
Smokestack, inside diameter.....	14 inches
Smokestack, top above rail.....	12 feet 1 inch
Boiler supplied by two Sellers injectors, Class "N" improved of 1887, No. 8 1/2.....	
Tender.	
Weight, empty.....	25,750 lbs.
Wheels, number of.....	6
Wheels, diameter.....	36 inches
Journals, diameter and length.....	4 1/2 inches diameter by 8 inches
Wheel base.....	10 feet 2 inches
Tender frame.....	Steel plate and channels
Water capacity.....	2,400 U. S. gallons
Coal capacity.....	3 tons
Total wheel base of engine and tender.....	40 feet
Total length, engine and tender.....	48 feet 10 inches

These locomotives have Coales 2 1/2-inch encased pop safety valves, Detroit double sight feed lubricators, Smith's automatic vacuum brake on driving and tender wheels, spring buffers on front of engine and rear of tender and between engine and tender, Crosby chime whistle, Ashcroft steam gage, and three eight-inch bull's eye headlights.

THE Q & C SCOTT BOILER FEEDER.

A new device for forcing feed water into steam boilers, manufactured and sold by the Q & C Company, is shown in the accompanying illustration. A pamphlet received from the manufacturers contains an explanation of its construction and operation upon which the following description is based:



Eight Wheel Schenectady Locomotive for The Imperial Railway of Japan.

Wheels and Axles.	
Diameter of driving wheels outside of tire.....	54 inches
Material of driving wheel centers.....	Cast iron
Tire held by.....	Shrinkage
Driving box material.....	Steeled cast iron
Diameter and length of driving journals.....	7 inches diameter by 8 inches
Diameter and length of main crank pin journals (Cambria Steel Coffin process).....	4 1/2 inches diameter by 4 1/4 inches
Diameter and length of side rod crank pin journals (Cambria Steel Coffin process).....	3 3/4 inches diameter by 3 1/2 inches
Engine truck, kind.....	Four-wheel swing bolster
Engine truck, journal.....	4 1/2 inches diameter by 8 inches
Diameter of engine truck wheels.....	26 inches
Kind of engine truck wheels.....	National, steel-tired spoke center, 3-inch tire
Boiler.	
Style.....	Extended wagon top
Outside diameter of first ring.....	52 inches
Working pressure.....	160 pounds
Material of barrel and outside of firebox.....	Carnegie steel
Thickness of plates in barrel and outside of firebox.....	9-16 inch, 5/8 inch, 7-16 inch and 1/2 inch
Horizontal seams.....	Butt joint, sextuple riveted with welt strip inside and outside
Circumferential seams.....	Double riveted
Firebox, length.....	78 inches
Firebox, width.....	29 3/4 inches
Firebox, depth.....	Front, 55 inches; back, 43 inches
Firebox, material.....	Copper
Firebox, plates, thickness—Sides, 1/2 inch; back, 1/2 inch; crown, 1/2 inch; Firebox, water space—Front, 4 inches; sides 2 1/2 inches; back, 3 inches to 4 inches at crown	
Firebox, crown staying.....	Radial stays, 1 inch diameter
Firebox, stay bolts.....	15-16 inch soft rolled copper
Tubes, material.....	Solid drawn brass
Tubes, number of.....	196
Tubes, diameter.....	1 3/4 inches
Tubes, length over tube sheets.....	11 feet
Heating surface, tubes.....	980.17 square feet
Heating surface, firebox.....	93.5 square feet
Heating surface, total.....	1,073.67 square feet
Grate surface.....	16.04 square feet

Its objects are two in number; first, to supply boilers with water at a cost much below that entailed by the use of pumps; second, to automatically maintain a constant water level. In its operation an elevated closed chamber is filled with water. Steam is admitted to this chamber to balance the pressure from the boiler upon the feed pipe, and gravity is the sole force employed to carry the water thence into the boilers. In construction and operation the feeder is so very different from devices hitherto used for the same purposes, that at first sight one may fail to recognize how simple a matter it is. It works on entirely new lines. Its actions are direct and natural. A few well-known forces are applied in a new way.

The leading essentials of the boiler feeder consist of two receivers, called the primary receiver and the main receiver, a steam valve, a relief valve, a differential valve and check, admission and regulating valves, the latter two classes being used only when the machine is adapted to automatic regulation of the water level.

One of these receivers, cylindrical in form, is called the main receiver, and is located in some convenient position and slightly higher than the boilers. The main receiver is surmounted by a steam valve which is opened and closed periodically by the action of a float operated relief valve below the receiver.

The steam valve receives steam at boiler pressure, through a pipe leading directly from the dome or drum, or from some

suitable and convenient steam line. A discharge pipe connects the lower end of this receiver with the main feed pipes leading to the boilers.

The lower or primary receiver is also cylindrical in shape, but is terminated at its upper end by a long cone, to which is attached the steam pipe leading from the differential valve. This receiver is placed in any convenient location on the floor of the engine or boiler room, at a level sufficiently low to insure that it will fill with water from the feed heater, or from the return tank, by gravitation. It is attached to a tee in the connection between the heater and the main receiver, a check valve being placed on each side of the primary receiver. One of these is to prevent the water which has entered the primary receiver from being forced back to the heater. The other is to prevent the water from returning to the primary receiver after it has been driven to the main receiver.

From a point between the boiler and the check valve in the pipe, a small pipe, called the spray pipe, is taken and carried

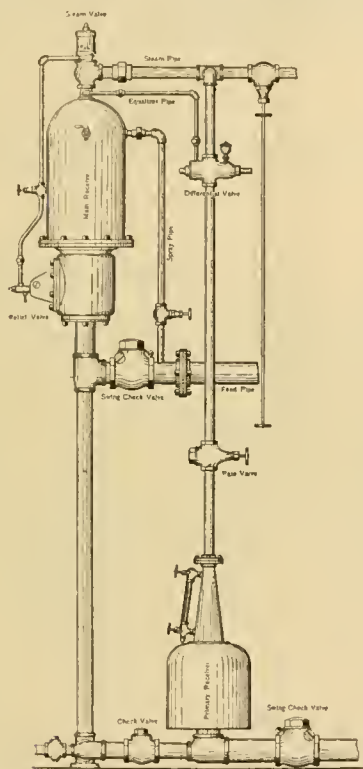

The Q. & C. Scott Boiler Feeder.

to a point near the top of the main receiver. At this point it enters the receiver and terminates on the inside in a distributing or spraying nozzle, set to play against a deflecting plate.

Just above the cone of the primary receiver is placed a pass valve, having a movable disc of peculiar construction. This valve is set in the steam line leading from the differential valve to the primary receiver.

A short pipe is taken from the steam line leading to the steam valve and is led to the primary receiver. In this connection is placed a differential valve, so termed because it is operated by differences of pressure existing at suitable intervals between the main and primary receivers. Besides the steam line leading to the differential valve there are two other pipe connections. One of these leads to the upper part of the main receiver and is termed the equalizer pipe, its office being to communicate to the differential valve, the condition of the main receiver as to pressure. The other is called the exhaust pipe and carries to the heater or to the atmosphere the small amount of steam which is exhausted from the primary receiver.

Just below the main receiver, and in the discharge pipe leading therefrom, a fitting is placed consisting of a chamber within which is a float mounted on a lever, operating a relief valve, which communicates by a small pipe with a space below a piston on the stem of the steam valve. The parts are named in the engraving, and with the following explanation the operation of the device may be understood.

When arranged to take hot water from an open heater, water from the heater enters and fills the primary receiver by gravitation, and is then driven to the main receiver by steam pressure admitted to the primary receiver through the differential and pass valves. When the main receiver is in this manner filled, the steam valve at the top rises and admits steam to the surface of the water. The pressure above the water balances the pressure from the boiler upon the check valve in the feed pipe, and the height of the column of water causes it to fall by gravity, discharging into the boiler. During the time when the main receiver is discharging into the boiler, the primary receiver is re-filling, the steam to force the water from this primary receiver being alternately admitted or cut off by the actions of the differential valve.

The motions of this valve are governed by variations of the pressure in the main receiver, communicated by the equalizer pipe, in such a way that while the main receiver contains full boiler pressure the valve is closed, but when pressure in the main receiver is reduced by a few pounds the valve is opened. When the primary receiver has re-filled, it awaits the reduction of pressure in the main receiver, which is needed to open the differential valve.

Now, assuming the primary receiver to be filled with water and the main receiver to be discharging, the latter will contain full boiler pressure and the differential valve will be closed. The main receiver will continue to discharge until the water recedes to such a level as to allow the float of the relief valve device to fall. This closes the steam valve above and confines a volume of steam equal to the capacity of the receiver above the water level. At this natural radiation with its consequent condensation, almost instantly causes a slight reduction of pressure in this receiver below the pressure in the boiler, and this small reduction permits water to be driven back to the main receiver through the spray pipe, which is connected as before described to the boiler feed pipe.

The spray, which this returning water forms by impact against a deflecting plate, falls through the steam and instantly causes a much greater reduction of pressure, amounting generally to thirty or forty pounds and sometimes to a much greater difference. This fall of pressure opens the differential valve and admits live steam to the surface of the water in the primary receiver, and now full pressure in the latter drives the water to the main receiver. As the main receiver fills, its pressure rapidly recovers until it equals that of the boiler. The differential valve then closes, thus allowing the steam in the primary receiver to exhaust and enabling the receiver to re-fill with water, which condenses whatever steam remains, thereby absorbing all the thermal units therein contained. A repetition of these actions makes the operation of the device continuous.

The device is also applicable to closed heaters and it may be used with water taken from a well or cistern. It may also be used for supplying a battery of boilers for each of which automatic regulating devices are applied. The claim most strongly urged for the device is that of economy of operation, as compared with steam pumps. The manufacturers have taken pains to inform themselves as to the comparative cost of operation of this feeder and pumps, and are prepared to give the results of tests. Further information may be obtained from the Q & C Company, of New York and Chicago.

Trolley cars from Brooklyn are now running at regular, but rather long intervals into New York over the Brooklyn Bridge. They will soon be making more frequent trips, and the transition of the bridge from an isolated affair to a part of what may be called trunk line service will be complete.

COAL CARS, 80,000 POUNDS CAPACITY—CHICAGO & EASTERN ILLINOIS RAILROAD.

The Chicago & Eastern Illinois has ordered a number of 80,000-pound capacity wooden coal cars from the Haskell & Barker Car Company, to be built to designs and specifications prepared by Mr. T. A. Lawes, superintendent of motive power, to whom we are indebted for the drawings.

The stakes of these cars are arranged inside of the siding,

sills are 9 by 11 3/4 inches in section. The draft timbers are of 5 by 6 inch oak, and the needle beams are 4 by 10 inches of the same material. Southern yellow pine flooring 1 3/4 by 6 inches is used, and the siding is 2 by 10 1/2 inches. The car has eight 1 1/8-inch truss rods, four of which are carried to a height of 7 1/2 inches above the body bolster, while the other four are 3 1/4 inches above it, as shown in the sectional view of the floor.

The trucks are of the form designed and patented by the Haskell & Barker Company. The side frames are of the diamond, arch-bar pattern, upon which a built-up bolster is mounted.

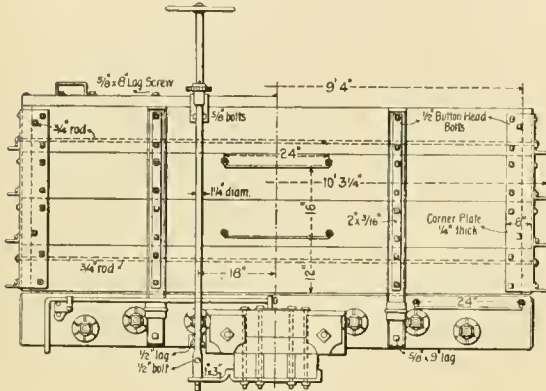

Half End Views.

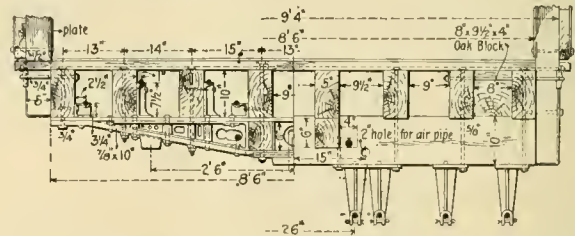

Half Section at Body Bolster. Half Section at Needle Beam.

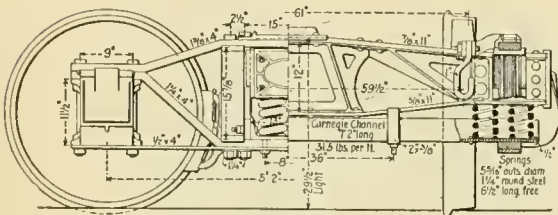

Metal Truck.

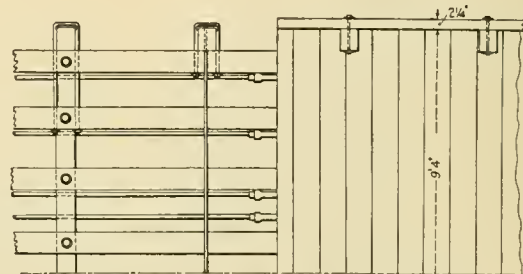

Plan Showing Underframe and Floor.

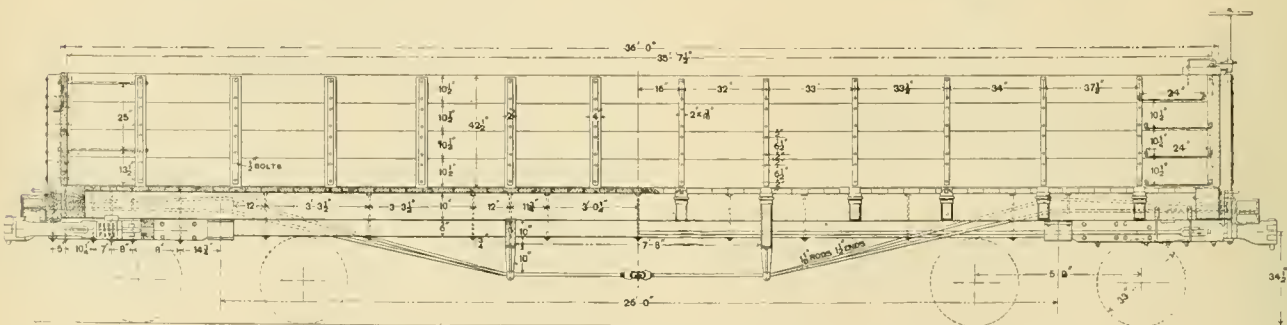

Gondola Coal Car, 80,000 Pounds Capacity, Chicago & Eastern Illinois Railroad.

Designed by T. A. Lawes, Superintendent of Motive Power.

which permits of using a comparatively low side, and widens the body of the car materially. The capacity of these cars, when level full, is 1,176 cubic feet, or 1,050 bushels, and they have carried loads of 83,500 pounds of coal. The length, inside, is 35 feet 7 1/2 inches; the width, inside, is 9 feet 4 inches, and the height of the sides is 3 feet 6 1/2 inches. The length over end sills is 36 feet. The stakes are secured at the bottom by three-quarter-inch bolts and five-eighths-inch carriage bolts.

The engravings show the framing and the method of constructing the car and the trucks. There are eight longitudinal sills, 5 by 10 inches in section, all of yellow pine, while the end

The bolster has steel plates for its top and bottom members, with peculiar shaped malleable iron filling blocks between. The top plate is 7/8 by 11 inches, and the bottom plate is the same width, but five-eighths of an inch thick. The spring plank is replaced by a 13-inch Carnegie steel channel, and the bolster rests upon the tops of the springs. The body bolster has a straight top plate 3/4 by 10 inches, and a bottom plate 7/8 by 10 inches, separated by filling pieces of malleable iron castings, which gives the bolster a depth of 10 inches at the centre.

The axles are of steel, with 5 by 9 inch journals. The Westinghouse brake and Tower couplers will be applied.

POWERFUL SIMPLE LOCOMOTIVES FOR THE GREAT NORTHERN RAILWAY.

Last month we printed an illustrated description of one of the new Mastodon locomotives, built by the Brooks Locomotive Works, for the Great Northern Railway and now present a few additional notes with regard to the interesting design.

The chief features are the large cylinders, piston valves,

also be noted that the area of the passage of the exhaust steam after passing out of the cylinder port is very large, and free escape of the exhaust steam is provided. This is an important matter with such large cylinder volumes, especially as the engines will undoubtedly be worked at a comparatively late cut off. The cylinders are provided with two-inch pop valves, as shown in the sectional view and we are informed that extra precautions were considered necessary on account of the excessively cold climate of Montana, which might

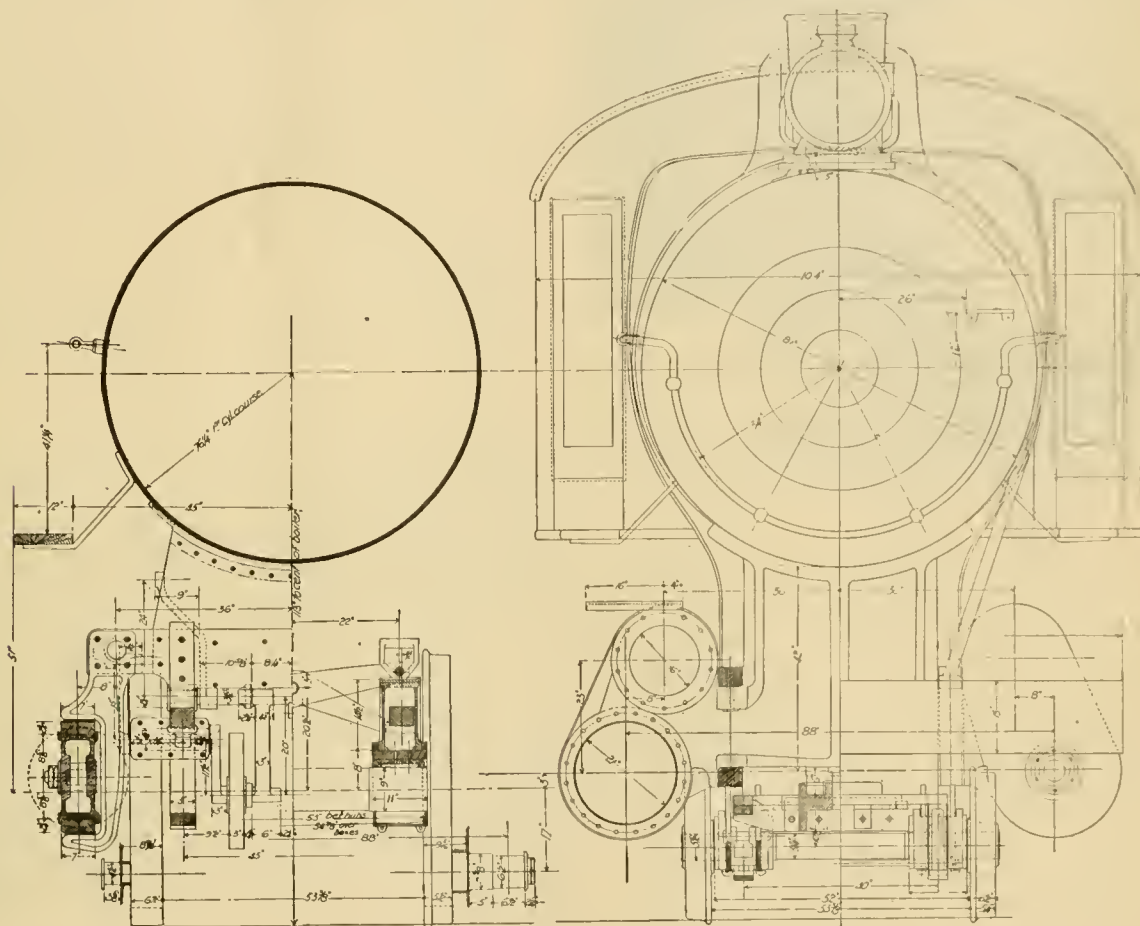

Front Elevation and Sections through Running Gear.
Powerful Simple Locomotives—Great Northern Railway.

absolutely balanced, and the extraordinary boiler capacity. These were provided for extremely severe service in the cold climate and high altitude of Montana. We are informed by the builders that the engines are to be used upon a long continuous grade of 2.2 per cent., and while the exact load to be hauled up this incline is not stated, we believe that it will be about 600 tons. At all events, the engines will be worked to their limit of capacity and it is understood that one fireman is expected to be able to take care of the fire. These engines have already been tested on an 87 foot grade, combined with curve of four degrees, out of St. Paul, over which they hauled a load of 32 cars, weighing 1,070 tons; the mean effective pressure in the cylinders being 189.5 pounds, or about 95 per cent. of the maximum boiler pressure while doing this work. The pop valves at this time were set to blow off at 200 pounds.

The form of the cylinder castings, including the valve chests with the lagging removed is shown in one of the accompanying engravings, which illustrates a half saddle with one cylinder complete. From this engraving and the longitudinal section through the cylinder and valve on page 3, of the previous issue, the very short passage of the steam from the chest to the cylinder is seen at a glance. It should

cause trouble in case of careless handling. By referring again to the sectional view showing the cylinder and piston valve it will be seen that the bushings for the valves are inserted at each end of the steam chest and also that the valve stem is guided at both ends. This drawing also shows the construction of the piston and also in a general way that of the piston rod, but the rod is better illustrated in the detail drawing shown herewith.

The piston rods are hollow and 4 1/4 inches in diameter over

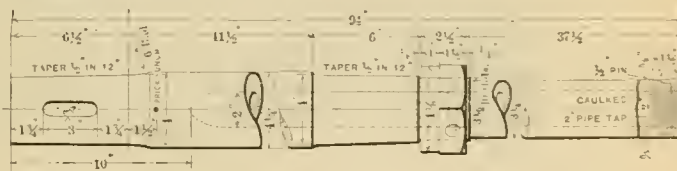

Hollow Piston Rod.

the main portion, the extended end being 3 1/4 inches in diameter. The length of the rod and other details of its construction with the diameter of the hole are shown in the drawing. Attention is directed to the fillet, with a six-inch radius, at the crosshead enlargement. The crossheads are made of open

hearth cast steel, with bronze gibs, the wearing surfaces of which are not tinned.

The crank pins, rocker shafts and crosshead pins are hollow. The holes in the rocker shafts and in the main crank

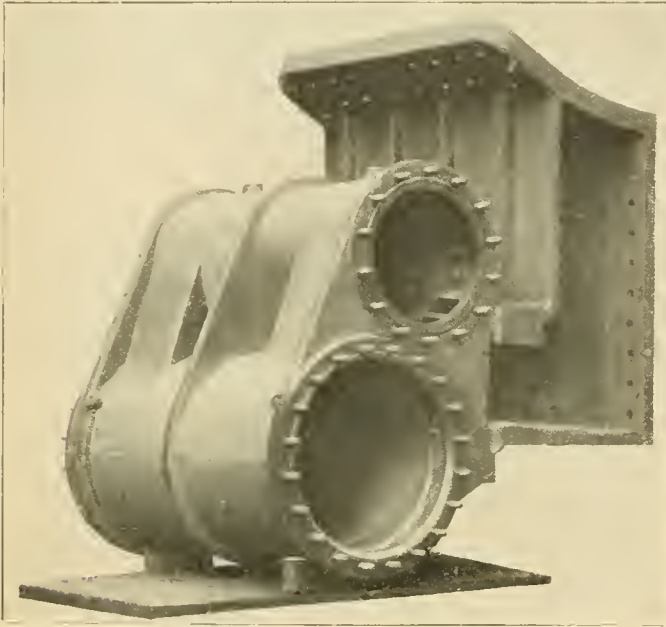

Cylinder of Great Northern Locomotive.

pins are two inches in diameter, while those in the forward crank pins are $1\frac{1}{4}$ inches, and in the third and fourth crank pins they are $1\frac{3}{4}$ inches. All of the crank pins are of steel.

The locomotives are now at work and their performance will be watched with great interest, not the least of the reasons for this being the fact that they are not compounds, and that they may be compared with the large compounds of the same number of wheels on the Northern Pacific, illustrated in our issues of March and April of last year.

COMBINATION ELECTRIC CONSTRUCTION CAR.

The J. G. Brill Company have recently built a special form of car for the Lorain & Cleveland Railroad Company, which

is placed a vestibule enclosed on all sides and fitted with drop sash. A canopy, carrying the trolley board, extends over the whole car. The length of the body is 24 feet, width 6 feet 1 inch; sills are of yellow pine plated $3\frac{3}{4}$ inches by 7 inches. The plates are $\frac{5}{8}$ inch by 8 inches. The stringers are $3\frac{1}{2}$ inches by 7 inches, and the flooring $1\frac{3}{4}$ inches of yellow pine. The sides are hinged, the hinges extending all the way across. The sides, which are 24 inches high, are hinged in three sections; at the rear the end drops in a single piece.

The car is fitted with four "G. E. 57" motors and it is equipped with electric brakes. The wheel base of the trucks is 5 feet 9 inches. The wheels are 33 inches in diameter and the gauge is 4 feet $8\frac{1}{2}$ inches. There are two truss rods to hold up the center of the body. The car is of the ordinary construction type, and, for use in winter, a detachable nose plow with wings and fittings are provided and in the center of the car a separate independent sand feed is arranged, besides which there are two sand boxes placed in the body of the car to be operated by hand. This arrangement of plow and wings is very effective and as it can be removed when it is desired to use the car for construction purposes, makes it especially valuable. The large boxes in the center of the car are used for handling salt or sand. There is an alarm gong and a plain arched roof is provided with curtains so that the sides can be closed in case of necessity.

When the sanitation and ventilation of passenger cars become appreciated as forming a basis for effective advertising it will no doubt be fashionable to give the proper amount of attention to these very important subjects. It is a matter for congratulation, however, that several roads, such, for instance, as the Illinois Central, the Big Four and the Chesapeake & Ohio, have gone very fully into sanitation with, we believe, the motive of running clean cars for the sake of the health of their patrons. We see clear indications of the absolute necessity for the same strictness with regard to sanitation in the case of railroad cars as is required in the case of ships under the United States quarantine regulations, and for the same reasons that apply to ships. It will be far better for the roads themselves to take up this sanitation than to wait until they are compelled to do so by State or interstate regulation. It is idle to argue the advantages of clean cars and clean air; it may be considered as settled that the public will have them both, and much credit will be gained by the roads that take the initiative in these matters. A great deal has been written with regard to the great difficulties in ventilating cars. We will not add to this except to urge the best possible use of the present appliances. The trainmen on most lines may be said to be dying for something to do to occupy their time between stations, and it is certain that they may be instructed and compelled to do much to relieve the present



Combination Construction Car—The J. G. Brill Company.

from its convenience and the fact that it may be utilized in case of necessity as a snow plow, makes it worthy of attention. The body of the car is that used in the ordinary type of construction for cars for suburban roads. It is mounted on a pair of "Perfect" Brill No. 27 trucks. At the forward end

abominable conditions as to ventilation. It should also be said that if the disinfecting and cleaning are carefully done, the factor that renders the lack of proper ventilation most effective will be removed and the quantity of air required by each passenger will be less, and this tends to show the very great importance of the cleaning and the fumigating.

THE BLACK DIAMOND TRUCK.

A patent has just been granted to Mr. R. W. Oswald for a steel truck, known as the "Black Diamond Truck," which is controlled by the Bloomsburg Car Manufacturing Company, of Bloomsburg, Pennsylvania. The design shown in the accompanying engraving is for a 60,000-pound capacity car, and it is interchangeable with the Fox pressed steel truck. The arch bar side frame is used and the whole construction is made up from commercial shapes. The arch bars are of 5 by 3½ inch Pencoyd Ts, weighing 16 pounds per foot. The transoms are of 12-inch I-beams, or if desired channels may be used. The springs are 7 inches high, mounted upon the tops of the boxes, as shown in the drawing. For the purpose of strengthening the truck the transoms project through the side frames, and a ¾-inch plate, 16¾ inches wide, tapered at its ends and bent to fit under the angles

WASTEFULNESS OF AUXILIARY ENGINES.

In our September Issue, 1897 (page 310), attention was called to the great number of auxiliary engines in warships, and comment was made upon the practice of exercising the greatest care in designing the main machinery of large power units and neglecting the smaller ones, the great number of which often renders them of great importance in a large stationary plant or on shipboard. In support of our criticism, we are pleased to quote the "Electrical World," especially as regards the desirability of better transmission of power:

"It is not an uncommon sight to see a large generating station equipped with high-class steam machinery and striving for the highest economy in operation by the use of elaborate steam-saving devices, condensers, economizers, etc., furnished with boiler-feed pumps, which consume about 150 pounds of steam per horse-power hour. This is the kind of economy that calls to mind a variety of proverbs, conspicuous among them one concerning the spigot and the lung-hole.

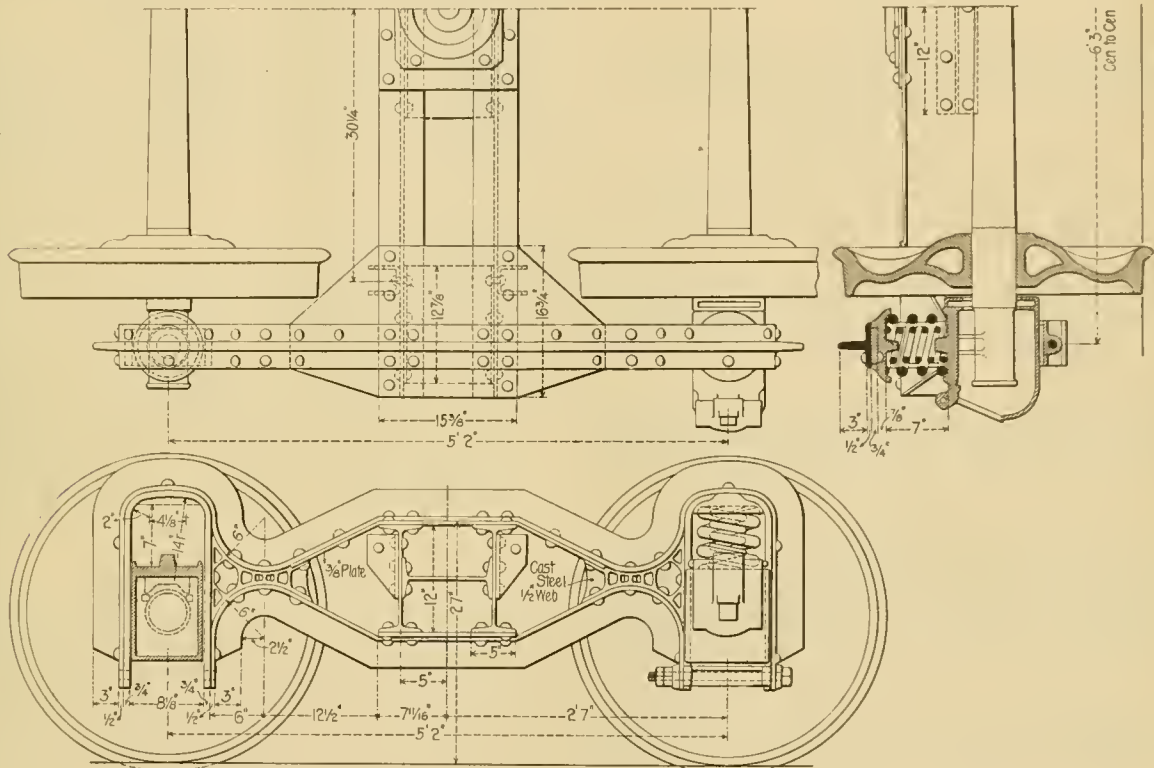

The Black Diamond Steel Truck.—The Bloomsburg Car Manufacturing Co.

of the side frames, forms the connection between the transoms and the side frames. This plate is riveted to the transoms and to the Ts, as shown in the engraving.

The side elevation shows the curved shape of the side frame members which are bent at the boxes to radii of 6 inches, and are secured to steel castings having ribs, the webs being ½ inch thick. These castings bear against and are riveted to the pedestal liners which are ¾ inch thick and extend over the top of the spring seats, making an arch with a radius of 14 inches. These liners are carried to the bottom of the box openings forming the jaws, and they are secured under the boxes by the tie pieces and bolts. The brake hanger brackets are shown in the engraving and it will be noticed that an I-beam brace, 12 7/8 inches long, is placed horizontally across between the transom I-beams at the ends. The transoms are also braced at the center under the center plate by a similar I-beam, somewhat longer than those at the ends.

The engraving is sufficiently clear to be understood with this brief description. These trucks have been specified on 10 gondola cars now building at the works referred to.

The large source of waste in pumps of this character is frequently sufficient to bring the operating economy of the plant down to a point which is surprising alike to engineer and financier.

"The plain and effective remedy for this trouble is the use of electric-motor driven pumps, which operate at an efficiency quite approaching that of the main generating plant. Such pumps have already come into use in many of the best-designed plants, and there is no reason whatever why their use should not become practically universal in electrical-generating stations. In point of cost they compare quite favorably with the ordinary duplex-plunger steam pump, while repairs on them are both less frequent and less expensive. Their perfect control, the automatic methods that may be readily adapted to them, their high efficiency compared with other forms of boiler-feeding pumps, are all points which should be carefully considered by those designing steam plants for electric supply. To-day the only leak of any importance in the ordinarily well-designed station is in the pumps, and it would be a matter of interest in many stations showing only fair economy where a better performance could be looked for to compare the present cost of producing a given result with that which would follow the installation of electric pumps. The donkey pump, while probably the worst offender of its kind, is not the only auxiliary common in steam plants to which electric motors may be applied with satisfactory results. A case in point is in connection with the steamer Kaiser Wilhelm der Grosse, on which sixteen forced-draught blowers are operated by electric motors."

(Established 1832.)

AMERICAN ENGINEER

CAR BUILDER AND RAILROAD JOURNAL.

29TH YEAR.

67TH YEAR.

PUBLISHED MONTHLY

BY

R. M. VAN ARSDALE,

MORSE BUILDING.....NEW YORK

G. M. BASFORD, Editor.

FEBRUARY, 1898.

Subscription.—\$2.00 a year for the United States and Canada; \$2.50 a year to Foreign Countries embraced in the Universal Postal Union.

Subscriptions for this paper will be received and copies kept for sale by the Post Office News Co., 217 Dearborn Street, Chicago, Ill.

EDITORIAL ANNOUNCEMENTS.

Advertisements.—Nothing will be inserted in this journal for pay, EXCEPT IN THE ADVERTISING PAGES. The reading pages will contain only such matter as we consider of interest to our readers.

Special Notice.—As the AMERICAN ENGINEER, CAR BUILDER AND RAILROAD JOURNAL is printed and ready for mailing on the last day of the month, correspondence, advertisements, etc., intended for insertion must be received not later than the 20th day of each month.

Contributions.—Articles relating to railway rolling stock construction and management and kindred topics, by those who are practically acquainted with these subjects, are specially desired. Also early notices of official changes, and additions of new equipment for the road or the shop, by purchase or construction.

To Subscribers.—The AMERICAN ENGINEER, CAR BUILDER AND RAILROAD JOURNAL is mailed regularly to every subscriber each month. Any subscriber who fails to receive his paper ought at once to notify the postmaster at the office of delivery, and in case the paper is not then obtained this office should be notified, so that the missing paper may be supplied. When a subscriber changes his address he ought to notify this office at once, so that the paper may be sent to the proper destination.

The paper may be obtained and subscriptions for it sent to the following agencies: Chicago, Post Office News Co., 217 Dearborn Street. London, Eng., Sampson Low, Marston & Co., Limited St. Dunstan's House, Fetter Lane, E. C.

ANNOUNCEMENT.

A series of articles on the Construction of a Modern Locomotive, by a motive power officer of one of the leading railroads of this country, will commence in our March number, and will treat the subject in a practical manner, from the ordering of the material to the testing of the finished locomotive. This will be a valuable record, based upon a wide practical experience, and as only a limited number of extra copies will be printed, you are urged to subscribe before the publication of the March issue.

The advances of recent years in regard to the power and capacity of machine tools has led to the refitting of many progressive shops and in fact the shops that have not been pretty thoroughly equipped with new tools within a few years are not to be considered as being up to the times. They certainly are not in condition to compete with well equipped shops as regards the cost of work. Several successful manufacturing establishments might be mentioned as having found it a money-saving operation to throw away a great deal of their old machinery and replace it with new, and the superior capacity of modern tools is often such as to warrant this

course, even at considerable sacrifice. In arguing for the improvement of the Government plants at navy yards Mr. George W. Melville, Chief of the Bureau of Steam Engineering, in his annual report cites a case of a large firm with what was considered one of the best plants in the country, that recently broke up good tools valued at \$40,000 because they were becoming antiquated, and they were replaced with new tools at an expense of \$200,000. It is not necessary for all to go as far as that, but this instance serves to show the opinion in which up-to-dateness is held, and in many shops a judicious selection of old machinery could be retired with advantage.

An important suggestion with regard to the duration of locomotive boiler tests is made in another column in this issue, which seems to possess sufficient merit to warrant attention by the committee of the American Society of Mechanical Engineers, in whose charge is the revision of the code of rules with regard to the testing of steam boilers. This committee has a difficult task, but it seems appropriate to suggest that the testing of locomotive boilers is of sufficient importance to justify special provision, if it is thought that the code would be complicated by carrying out the idea presented, viz., that not the time of the test, but the quantities of coal and water used should govern. It is out of the question to run locomotive tests for ten hours, the minimum suggested by the committee, and it is impossible to run a locomotive boiler under a draft as light as that prescribed for stationary boilers. The point we make is that the code if it is to fulfill its object must not provide conditions under which so large a class of boilers as are represented in locomotive service cannot be tested. The code may be made very much more valuable if locomotive conditions are considered, and it is so difficult at best to secure reliable data from locomotive boilers that every encouragement should be offered to those who are seeking it. The American Society of Mechanical Engineers will probably not ignore the claims of the locomotive interests in this code when attention is directed to the matter.

The practice of pooling locomotives has been strongly defended by those who have had recent experience with it, and it is argued against by others who are equally entitled to express intelligent opinions. Its advocates make such a strong case, however, that a consideration of the subject by those who are not using it seems advisable, even if the opinion that pooling does not possess the advantages claimed for it, has become firmly fixed. As generally understood the term pooling is now applied to the practice of providing more engine crews than engines; the men are not assigned to particular engines, the crews and the engines being assigned to trains independently. It has long been the practice on many roads to operate one engine with more than one crew and this is considered by some as a form of pooling, although individual crews are held responsible for the condition of the engines. The greatest difference between the two systems lies in this matter of responsibility. While in pooling no individual has the permanent care of the engine such care in what may be called the multiple-crew system is given to one of the crews. Strong claims are made by the pooling system for greater mileage, a decrease in the number of engines required to do a given amount of work, the handling of heavier trains, reduced cost of repairs and mutual advantages between the railroad and the men. Pooling is also claimed to provide a satisfactory remedy against the temptation of the men to overwork for the purpose of increasing their earnings. Those who argue against pooling take up these advantages in turn and claim that they may all be obtained equally well with a proper administration of the regular crew system. They urge the importance of the idea of individual responsibility for the care of the machinery and believe that it is impossible to provide this in the pooling system. To this the advocates of pooling

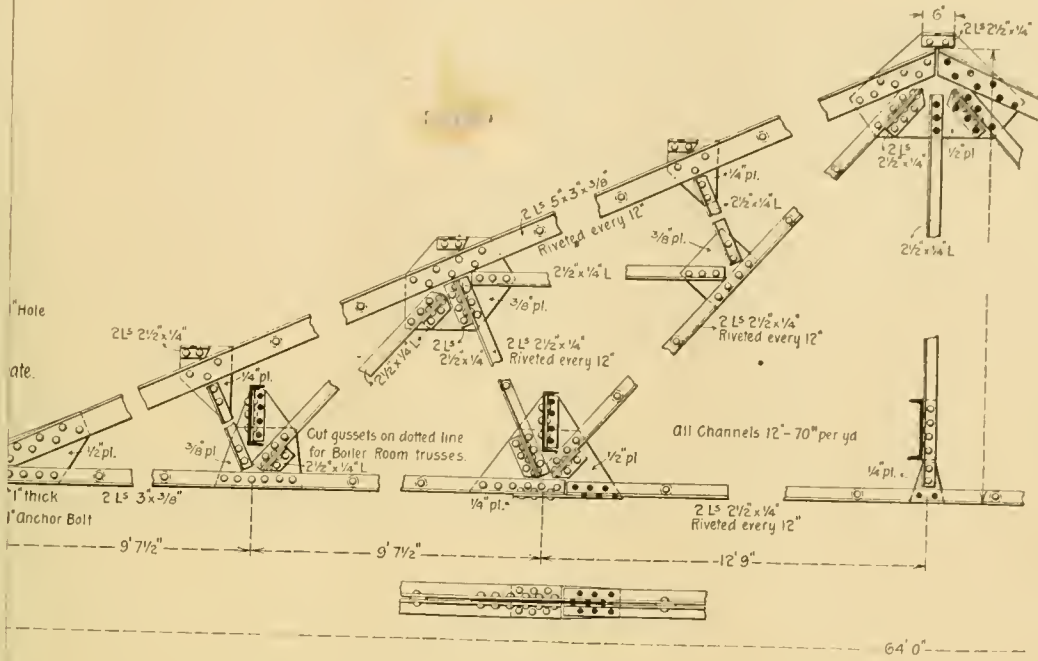

Roof Truss of Power House.

than is now possible, and a plan is being developed that think worthy of the thought and attention of all who have economical. The fact seems to have been lost sight of, that

s
e
e
s
o
is
n
or
h
a
id
in

at
al
15
be

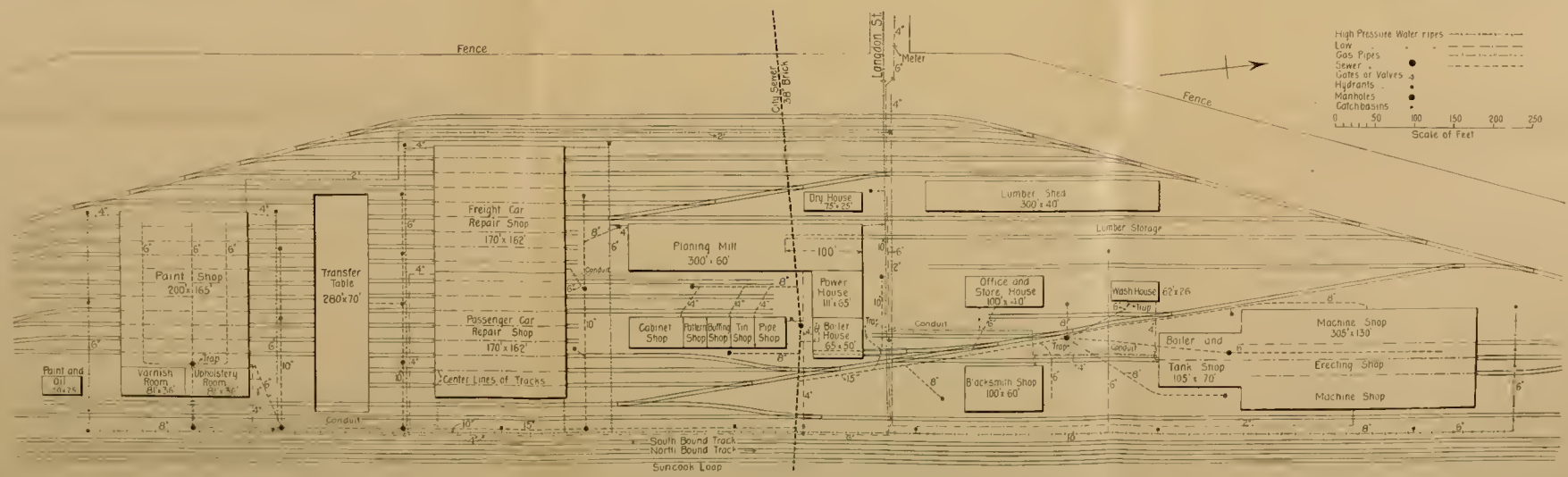
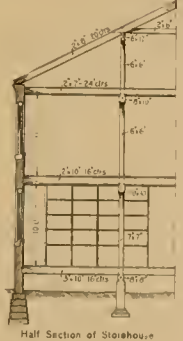
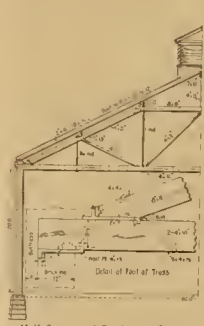
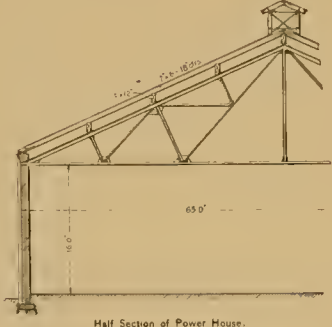
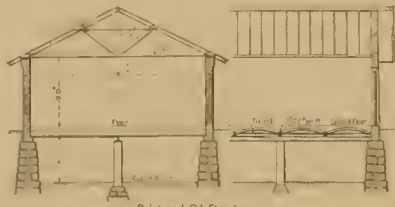
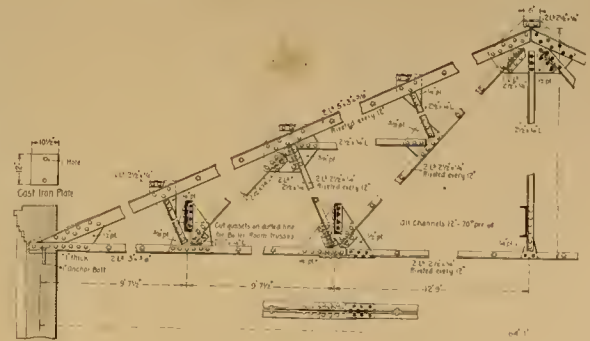
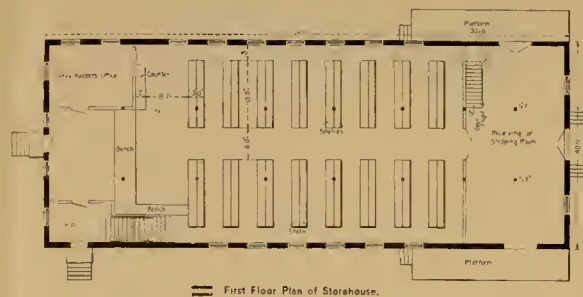
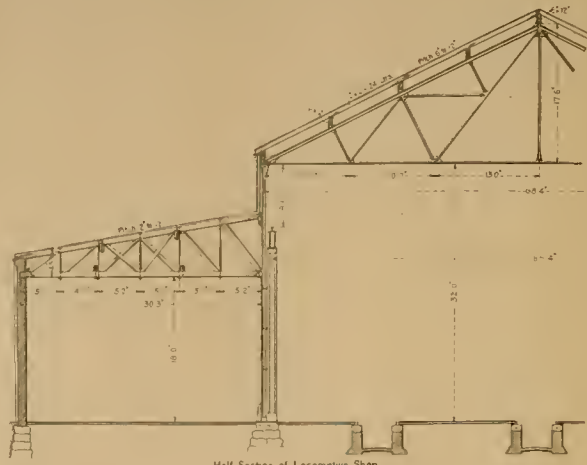

NEW LOCOMOTIVE AND CAR SHOPS, BOSTON & MAINE RAILROAD, CONCORD, NEW HAMPSHIRE.

reply that with solid end rods and similar provisions the enginemen may be relieved of working on the machinery itself and that individual care may be delegated to the roundhouse forces, after insisting upon reports of needed work from the men who run the engines. They also urge that enginemen when regularly assigned to engines are likely to be so careful of them as to prevent the best service from being obtained. To one viewing the discussions of the subject from an outside standpoint the following conclusion may be reached: It is important to load engines to the maximum practicable capacity, to keep them in service as continuously as possible and to maintain them at all times in the best possible condition for service, and it is believed that special conditions surrounding roads in different localities may in some cases be met by one system better than by the other. In either case the factors which form the basis of the strong claims made for pooling should be provided for, and those who do not favor pooling say that this may be done. It is clear that the advocates of pooling have, as a rule, considered what may be termed the business questions of operation, to a considerable extent, but these should be applied as thoroughly to the regular crew system before a satisfactory estimate of its value may be obtained.

The law requiring the height of draw bars above the rail to come within the limits of 31½ inches, as a minimum, and 34½ inches, as a maximum, appears to be giving considerable trouble, on account of difficulties in taking the measurements and because the limits are very narrow. It has been found that variations of one and one-quarter inches in measurements on the same coupler may be had by moving the car along a piece of ordinary yard track. Yard tracks are usually in very bad surface, and it should not surprise any one that the coupler will be depressed by a particularly soft joint. The remedy against injustice in inspections for compliance with this rule is to take the measurements upon a good piece of track. Another difficulty lies in the fact that the underframe of a car has vertical flexibility under a load, tending to deflect by sagging at the center and raising the ends, and this may be sufficient to change the height of the couplers of a car to make it exceed the maximum limit. This can only occur when the cars are raised to nearly the maximum limit when empty, and as the complaints are for cars too high rather than too low this suggestion is important. Yet another difficulty in this connection arises from the fact that a car may come within the limits if adjusted when the wheels, bearings and journals are old and the bolts are loose, and, when new parts are applied the car begins to go up and is soon too high. It is beginning to be realized that the limits are very narrow, and it is evident that care must be taken in the measurements and in the adjustments.

The committee on laboratory tests of brake shoes has done some of the most thorough, as well as difficult, investigative work ever presented to the mechanical railroad associations. There are many more investigations that should be made and it is not to be expected that the testing work is to be continued as it was begun, viz., by a committee, and yet it ought to be done by disinterested people under the direction of the committee. It casts no reflection upon the committee to suggest that the subject of friction as concerns car and truck wheels has thus far been attacked only at its edges and that there is enough left to be done to occupy the best of investigators for a long time. Besides this new shoes are continually being brought out, and it will be remembered that tests upon these were provided for when the committee was made a standing one in 1896. With the machine available also it seems too bad that it should not be used more continuously than is now possible, and a plan is being discussed that we think worthy of the thought and attention of all who have

an interest in the subject. It has been suggested that the machine, now at the works of Westinghouse Air-Brake Company, be transferred to the laboratory of Purdue University at Lafayette, and it is understood that the brake shoe committee has made a formal recommendation to that effect to the executive committee of the Master Car Builders' Association and that the executive committee now has the matter under consideration. This plan has much to recommend it, and we would call attention to the great advantages of having experimental work of this kind carried on under the personal direction of Professor Goss, who has for a long time devoted so much attention to important practical railroad subjects. It is believed that this apparatus could not be placed in better hands. By setting the machine up at Purdue and placing it in charge of Professor Goss, under the proper restrictions, it is likely that the results attained will be far more valuable to the association than any that might be carried out by any other method. We understand that the University is ready to invest freely in preparing for the machine and it is believed that if the machine is placed there the Master Car Builders' Association will probably benefit as much from it as has the Master Mechanics' Association from the laboratory locomotive. We hope to see this plan carried out.

THE ADVANTAGES OF STEEL CARS.

Many railroad men, especially car builders, are shaking their heads and expressing grave doubts as to the ultimate success of the large capacity steel cars now being built. If such cars were immediately placed in interchange service we can readily see that they might be very troublesome, and it is doubtful whether they would be economical. It is proper, therefore, at the outset, in discussing the economics of large steel cars, to consider separately cars intended for special service on home roads, and those for general interchange over many roads. It now appears to be quite certain that the course steel car building will take in this country will be the development of metal cars of 80,000 and 100,000 pounds capacity, for coal and ore, stone and other heavy materials, in service on roads owning the cars, and the experience thus gained will gradually spread and demonstrate the proper construction for interchange cars.

Box cars for grain, merchandise and furniture are the principal ones used in interchange, and as the upper framing of such cars will for a long time to come be of wood, it is only the under frame which need be considered for steel construction in this service. Indeed, many car builders in the anthracite coal region are disposed to favor steel under frames for larger capacity coal cars, but they prefer wood for the upper frame. The experience with the 50-ton coal cars now in service will soon develop many points which will be useful in designing under frames for any class of cars, whether box or coal cars.

The principal item of economy in the use of steel cars is the fact that they render larger capacity possible, and produce an increase in average paying load of trains due to decrease in dead weight. It is a triumph of good design and strong material, when steel ore cars to carry 50 tons are built to weigh no more than one built of wood, having only 30 tons capacity, and this is actually true in the case of the Schoen ore car. But for coal, in order to get sufficient capacity for 100,000 pounds, a larger car will be required, and it will weigh about 40,000 pounds, as compared with 35,000 pounds for a wooden hopper car of 30 tons capacity. This increase in dead weight when cars are hauled empty has been urged as an objection to large capacity cars.

It has been a well worn argument repeatedly advanced at the Master Car Builders' conventions and in the technical press that the average load of freight cars is only 12 or 15 tons, and therefore cars of heavier dead weight could not be economical. The fact seems to have been lost sight of, that

this very average is based not on partly loaded cars, but it is kept as high as it is by cars running fully loaded in one direction and empty or nearly so in the other, and that the larger the capacity of the car the larger the average can be made, even if the car runs entirely empty in one direction. With existing low rates, railroad managers have arrived at the conclusion that in order to make freight traffic profitable it is necessary to increase the capacity of freight cars and decrease the proportion of dead weight to paying load. It is already demonstrated that it is easily possible to do this by steel construction, and for this reason steel car building will be a rapidly increasing industry. The advantages of cars of large capacity have been frequently stated in connection with what is called "the large car problem," and may be summarized as follows: A given tonnage is concentrated in fewer cars and shorter trains, resulting in reduced friction and atmospheric resistance, reduced empty car movement in direction opposite to heavy traffic, reduced switching service, reduced payments for car mileage and cost of inspection, reduced numbers of air brakes and couplers and an increase in traffic capacity of main line, of freight yards, side tracks and terminals. It has been estimated that in a train of 30 steel cars of large capacity there is saving in train length of 500 feet over that required for a given paying load in wooden cars.

The first cost of steel cars is higher, per car, when those of the same capacity are considered, and also per ton of capacity when cars of different capacities are compared. For example, it is understood that the 50-ton ore cars cost nearly one thousand dollars, while a 30-ton wooden hopper coal car costs about five hundred dollars, the cost per ton for the steel cars being twenty dollars, and for the wooden car sixteen dollars and sixty cents. But considering the numerous traffic advantages, the greater durability resulting in longer life and less cost of repairs, the higher priced steel car can be shown to be more economical in the end. The life of wooden cars is usually taken as about fifteen years. The probable life of the large steel cars now building is a matter of great uncertainty, the builders claiming fifty years with confidence. It is safe to assume that it will be at least thirty years, or double the life of the wooden car.

The greater strength of the material in steel cars must offer so much more resistance to the shocks and blows incidental to car service, and which have such a destructive effect upon wooden cars that they will have practically little effect upon the structure when made of steel. Any one going through a freight car repair yard must be impressed by the large amount of damaged lumber constantly being removed from cars and the quantity of new lumber required to take its place; and on all this lumber labor must be performed. Considering the destructive agencies at work in freight car service, the wooden car must be regarded as a temporary structure, requiring constant repairs and frequent renewal. It is reasonable to expect from experience of other countries with metal cars, and from the good service obtained from metal tender frames in this country, that steel cars will be permanent structures requiring few repairs and having a long life.

The average cost of repairs to wooden cars in from forty to fifty dollars per year. It ought to be safe to take the cost of repairs to steel cars of good design and construction as not exceeding twenty-five dollars per year for repairs and painting. From the figures given above we may now make an estimate of the cost per year and per ton capacity for 30 years' service of one 50-ton steel car and two 30-ton wooden hopper cars:

Cost new.....	Wood.	Cost new.....	Steel.
Interest, 15 years at 6	\$500	Interest, 30 years at 6 per	\$1,000
per cent.....		cent.....	1,800
Repairs, 15 years at	450	Repairs, 30 years at \$25....	750
\$45.....	675		
	$\$1,625 \times 2$ equals	3,250	$\$3,550$
	$\frac{30}{30} =$	\$108.33	$\frac{30}{30} =$
			118.33

$\frac{108.33}{30}$ equals \$36.11 cost per year per ton capacity for the wooden car, and
 $\frac{118.30}{50}$ equals \$23.66 cost per year per ton capacity for the steel car, a difference of over 52 per cent. in favor of the steel car.

In comparing the cost of repairs necessary to cars of such widely different materials as wood and steel, we have assumed that the rough handling and slight wrecks which are so destructive to wooden cars will not make much impression on substantial steel cars.

In the matter of deterioration, there is a widespread notion that steel cars will rapidly corrode, and that this action can be compared with deterioration by rot or decay in the case of wooden cars. It is well known that the posts and sills of stock cars have had a life of only about five years, and with much of the green and sap lumber used for coal and box cars renewals are often required, on account of rot, in eight or ten years. With lumber, this form of deterioration is not preventable, at least no preserving process has been used to any extent. With steel construction, however, a successful protective coating is probably the most vital thing connected with the life of a car. The investigations on the corrosion of metal cars, made by the Eastern Railroad of France have been published in this paper (issues of March, 1897, page 80, and April, 1897, page 117), and they showed that cars in service nearly thirty years have lost about six per cent. in weight in rust, and it was recommended that metal cars should be cleaned from rust and given two coats of paint every three years. Tender frames in service on the Chicago & Northwestern Railroad after twenty years had lost by corrosion about 10 per cent., and they required few repairs. With systematic cleaning and painting with a good protective pigment, it ought to be possible to preserve the life of a steel car for thirty or forty years, or at least to a sufficient age to warrant the increased first cost over wooden cars. With the admirable work in steel car design already done, we should not expect many failures from structural weakness, but success so far as economy is concerned depends more on the prevention of corrosion than upon anything else.

Protective coatings for steel structures have been the subject of extensive investigation in recent years, and the literature on the subject is quite voluminous. We can refer to one extensive resume of the different rustless coatings, which we believe is disinterested and ought to be reliable, namely, the four papers in the Proceedings of the American Society of Mechanical Engineers, Volumes XVI. to XVIII., by Mr. M. P. Wood. There is still a disagreement among bridge engineers as to whether steel should be primed with a coat of red lead or with mineral paint. Both have strong supporters, but nearly all are agreed: 1st. That a primary coat of linseed oil, at one time quite generally used, is not a good thing, as it is liable to wrinkle up and crack off. 2d. That mineral paint for priming should be anhydrous. 3d. That the surface should be thoroughly cleaned before any coating is applied. The cars referred to as being built at Pittsburg are being painted with a patent coating, which is comprised largely of asphaltum varnish. We are inclined to think that this will be too brittle and will crack off under the severe shocks and vibrations of service. While the subject is in a very unsettled state, yet if steel cars are carefully cleaned from scale and rust, and are then primed with good red lead or anhydrous iron oxide paint, and treated by the special paints for the second coat, they will be well preserved, and when repainting is required, a good, rustless coating will doubtless have been found.

From the above, it will be seen that we have abundant faith in the success of large capacity steel cars. They constitute the most important, the most revolutionary, and the most encouraging factor in the economy of freight transportation to-day.

THE ATLANTIC CITY FLYER.

We called attention in our issue of December, 1897, page 426, to the fact that some foreigners doubted the records that had been made by the Atlantic City Flyer on the Philadelphia & Reading Railroad. The subject became very interesting to those who watched the English technical press, and saw page after page given to arguments that were intended to prove that the statements with regard to that train were absurd, the basis of the contention being that such runs were impossible because they were not made in England. The trouble all came from a misunderstanding that was cleared up by the publication of Mr. Voorhees' letter in our issue referred to. We congratulate our English contemporaries that they may now devote their space to matters that are really novel, an attribute that does not apply to fast trains in this country.

Among those who did not clearly understand the reports was "The Engineer" of London, in whose columns quite a lively discussion was conducted, in which, by the way, the American locomotive did not suffer in comparison with its foreign brethren, and it was at last granted that our engines do really travel faster than English ones. After commenting in general upon the reliability of so-called "official" records, "The Engineer" says:

"In the United States our clever contemporary, the 'American Engineer and Railroad Journal,' took the trouble to apply to Mr. Theodore Voorhees, vice-president of the Philadelphia & Reading Railroad, enclosing some extracts from this journal. Mr. Voorhees' reply was published in the last issue of our contemporary which has reached this country. It is a very remarkable and suggestive communication. 'It is quite evident,' writes Mr. Voorhees, 'that the correspondents of 'The Engineer' are not familiar with the ordinary practice of reporting trains on railways in this country.' For that matter this want of familiarity is manifested by the United States technical press to the fullest possible extent, because the official report was accepted at the other side of the Atlantic without question, and would circulate still as the truth, were it not for the action we have taken. So much premised, Mr. Voorhees goes on to demolish certain pretty little edifices which have been erected to the honor and glory of the American locomotive by explaining in detail what is the ordinary practice of reporting trains. He tells us that 'It is customary for our telegraph operators to report the passing of all trains to the superintendent's office to the nearest minute in each case. On account of the exceptional speed of No. 25, an endeavor was made to report the train as accurately as possible, and, therefore, reports were given to the nearest quarter minute. These reports were according to the ordinary station clocks, which instruments are regulated by telegraph once each twenty-four hours, and, of course, are not to be considered as absolutely accurate. No one will pretend for a moment that the reports on July 5 at Meadow Tower and Atlantic City, one minute for one mile and seven-tenths, are correct. An error is manifest in that report. It is possible that errors exist in the report at other stations and on other dates.'

"This is a very satisfactory letter; we now know where we are. * * * Mr. Voorhees points out that this train has for two months accomplished its trips at the average speed of 69 miles an hour. This is a very fine performance, and one which Mr. Voorhees may justly be proud."

We may say that no record of fast trains, giving the time between given stations or mile posts is worthy of acceptance unless the time is taken by stop watches and properly checked. We thought every one knew this, and we thought every one understood the method of reporting trains in this country. The claim for this train was for making punctual runs at a rate of 69 miles an hour for two whole months. This has become history. The performance may be repeated and improved upon if necessary, for it is not believed that locomotives have ever been run as fast as it is possible to run them. "The Engineer" wishes to know how fast a locomotive can run, and why American engines can run faster than English ones? We an-

swer they may be run as fast as it is necessary to run them, and we do not believe that American engines can run faster than English engines. Our engines are more powerful, and they pull heavy trains faster. At the present day to discuss how fast an engine can run is wasting time. The locomotive meets present day speed requirements satisfactorily, and to make it run faster is a matter of design and of the nerve of the engine runner. The boiler power of American locomotives is needed in our severe service, and the discussion has drawn attention to this as a good factor in American locomotive design. In this connection a communication by Mr. W. M. Ackworth to "The Engineer," which is reprinted in part elsewhere in this issue is interesting, particularly as it indicates that English engines are lacking in heating surface and in adhesive weight, when compared with ours. This explains why they do not pull trains as fast as ours. The communication by Mr. Ackworth concludes as follows: "But I do not think it will be claimed for any locomotive at present running in this country (England) that it can maintain 70 miles an hour with 200 tons behind it on a dead level, and there are, I believe, a good many different types of engines which can do this in the States."

It is clearly demonstrated that American locomotives actually do run faster and with heavier trains, and that the English press is convinced of this is due to Mr. Voorhees and to "The American Engineer" for the publication of this letter, which has clinched the matter and set it finally at rest. We congratulate Mr. Voorhees, ourselves and the American locomotive upon this happy conclusion.

NOTES.

At the Liverpool street station of the Great Eastern Railway the traffic was worked for 20 years by one interlocking frame with 139 levers, and latterly 1,000 trains were dealt with daily. In 20 years this frame made 76,800,000 movements, equal to 10,520 per day.

The Boston Subway is nearly completed, and the report of Chief Engineer Howard A. Carson shows the rather novel situation of a large public work in which expenditures are below the estimates. The estimates call for \$5,000,000 and the expenditures amount to \$4,043,313.17.

Whether to reverse a locomotive equipped with driving brakes or to rely upon the brakes alone in making quick stops has been the subject of a number of communications recently printed in the "Railroad Gazette." The discussion points very decidedly toward the use of driver brakes alone, without reversing, as the proper method of making the quickest possible stop.

In connection with the electric cabs in Paris, the following costs of various methods of locomotion made by the Compagnie Generale and published in "The Practical Engineer" are instructive: Horse cab, 15 francs (44 cents) per day; petrol cab, 13 francs (20 cents) per day; electric cab (Krieger's), 8 francs (13 cents) per day. There is an economy of 47 per cent. over the horse and 32 per cent. over the oil motor.

It is reported that Mr. Thomas A. Edison has discovered an alloy whereby cast iron is rendered tough and yet it may be cast in moulds, and replace wrought and malleable iron for many purposes. Many discoveries have been made on this line, but so far they have all lacked the commercial requisite necessary for application on a business basis. If this feature is possessed by Mr. Edison's discovery its importance is very great.

The number of locomotives in Russia at the commencement of this year (1897) was 8,123. Of these locomotives about one-eighth were compound engines. Nearly one-half of the 8,123 engines were built in Russia, and of the whole number as many as 45 per cent. were built before 1880. The fuel used on 40 per cent. of the locomotives was coal, while 32

per cent. of the engines used petroleum, and 28 per cent. wood.—“Engineering.”

The Manhattan Elevated Railway, of New York, according to a statement recently made by Mr. George Gould, is to be equipped with electric traction with as little delay as possible. This is a large undertaking, as the trains now operated require over 300 steam locomotives, the annual car mileage being about 50,000,000 miles. It is expected that the lines will be extended and more tracks added in order to increase the capacity of the road.

The location of derailing switches in high speed tracks in the State of Illinois must hereafter be at least 400 feet from the fouling point whenever the conditions seem to require this. The rule has been changed to move the derails back 100 feet further because of the constantly increasing weight and speed of trains. The new rule will be carried out by Mr. W. L. Tarbet, Consulting Engineer to the Railroad and Warehouse Commission of that State.

The New York Dry Dock No. 3 has been found so badly constructed as to cast serious reflection upon the engineer in charge. The trouble recently discovered is with the sheet piling that was supposed to be driven to a depth of 47 feet or until hard bottom was reached. Much of it does not come up to this requirement, and Naval Constructor Bowles reports that some of these piles merely rest upon the mud, while others were driven from about four feet to seventeen feet in depth.

In considering the advances made in the construction of freight equipment at a recent meeting of the St. Louis Railway Club, Mr. C. B. Adams, of the Wabash R. R., gave the following table showing the increase in the ratio of load to car weights, from which the advantages of large capacity may be seen:

Year.	Weight of Car.	Weight of Load.	Total.	Load Per Cent. of Total.
1870	20,500	20,000	40,500	49.38
1880	22,000	40,000	62,000	65.52
1895	29,000	60,000	89,000	67.53

For some time the Baltimore & Ohio Southwestern Railway Company has been experimenting with crude oil for kindling fires in locomotives, in place of using cord wood, and the results obtained are reported to have been so satisfactory that it will hereafter be used on the whole line. During the month of November 1897, at the company's shops which are located at Washington, Ind., and Chillicothe, O., 1,226 fires were started with crude oil, at a cost of \$17,32, or 1.41 cents per fire. To have started the same number of fires with wood the cost would have been \$306, or 24.96 cents per fire. This represents a saving of \$288.68, and is very satisfactory.

Novel use is made of electric motors in constructing a sewer in Worcester, Mass. The conduit is 18 feet wide by 13 feet high and inside of this is a sewer 6 feet wide, partitioned off for the treatment of sewage by chemical processes. A coffer dam was built in order to permit of the construction of the partition wall, and for this work electric scows are used for the transportation of materials. The lighting and propelling currents are carried overhead and scows take current by trolleys. The boats are 27 feet long by 5 feet beam, with a paddle wheel in the center, driven by a motor and sprocket chain. The six boats handle 12,000 bricks, 50 barrels of cement and 100 barrels of sand daily. The whole equipment utilizes second hand apparatus.

A car for the transportation of oysters in tanks of sea water has been designed and built under the direction of President A. E. Stillwell, of the Kansas City, Pittsburgh & Gulf. It will run between Port Arthur, La., and Kansas City, Mo. There are four tanks, each provided with a ventilator through the roof, and through these the car is loaded. The sides of the

car, which are three inches thick, are cut for four hinged doors, made in the form of chutes, and these doors when closed are held tightly against the openings by clamps and bolts. The car has couplers for passenger trains. The capacity of the tanks is 8,200 gallons, the appearance of the car resembling a gondola coal with a roof.

A gas tube made by the Mannesman Tube Company, of New York, was tested at the Watertown Arsenal, and burst at a pressure (hydrostatic) of 5,863 pounds per square inch. The details of the test, as published in the reports of tests of metals for 1896, which has just been issued, show that the tube was 87 inches long by about 5½ inches in diameter, weighing 82 pounds. The fracture was in the form of a slit 13½ inches long near one end of the tube.

The elastic limit was reached at 4,710 pounds per square inch. The pressure was applied by means of a reservoir cylinder placed in the Emery testing machine, the piston of this reservoir being 3.37 inches in diameter and the maximum pressure upon it was 52,300 pounds. The test was made for the United States Signal Service.

Ernest Henry Saniter, in a paper read before the Iron and Steel Institute, Cardiff, August, 1897, details an experiment made by him to ascertain how much carbon could be taken up by pure iron without melting it. Very pure iron wire 0.04 inch in diameter was heated to about 900 degrees Centigrade for varying periods in a porcelain tube full of charcoal, and at successive stages the tube was allowed to cool and a portion of the wire removed for analysis.

After seven hours' heating an analysis showed 1.64 Centigrade. After 14 hours' heating it showed 2.79 Centigrade. After 27 hours 2.95 Centigrade, of which 0.53 was graphitic carbon and 2.42 combined carbon by difference.

It was concluded that the point of saturation was reached at 2.95 per cent., of which 0.53 was in the graphitic state.—“Sparks.”

The sand blast for cleaning locomotive tenders, preparatory to repainting them, is gaining favor in railroad paint shops “Engineering News” states that at the Dennison shops of the Pittsburg, Cincinnati, Chicago & St. Louis Railway, the sand blast has been used for cleaning the rust and scale from locomotive tenders for 18 months, and during this time the average cost of cleaning each tender ready for painting has been \$2.50. Considering the thoroughness of the cleaning and the durability of the work which follows, Mr. A. R. Lynch, the foreman painter at these shops believes that there is no other method so economical. Similarly favorable reports come from the Erie Railroad, where crushed quartz sand or quartz and deposit sand mixed half-and-half are used with an air pressure of from 100 to 125 pounds. A tank is cleaned thoroughly in about ten hours.

The Franklin Institute, in response to a request from the Board of Health of Philadelphia, has been carrying on the most extensive investigation of the smoke nuisance ever undertaken and the results are likely to have an important bearing on the future use of bituminous coal in stationary boilers and in locomotives in use in and near large cities. One of the best features of this investigation is the total absence of any indication of the work being influenced in the interests of any manufacturer or patentee of smoke consuming appliances. A set of resolutions has been passed expressing the opinion that the smoke nuisance may be abated and the Institute in its transactions is giving an elaborate report upon the various appliances for the abatement of the smoke nuisance. When this work is complete the record will be the most valuable collection of information to be had on this important subject, and it is likely to form the basis of legislation in many cities.

The new electric locomotive built by the General Electric Company for the Hoboken Shore road made its initial trip

over the tracks of that company on January 4. It was successfully tested as to its capabilities in hauling heavily loaded freight trains between the railroad terminals and the wharves of the trans-Atlantic liners on the Hoboken side of the North River. The trial was made over a line of track about two miles long. It consisted of drawing eight loaded freight cars, weighing in all about 260 tons, over the line and back again.

In appearance the locomotive resembles that used on the Baltimore & Ohio and the New Haven & Hartford railroads. It is somewhat smaller than the one used on the Baltimore & Ohio road.

Each truck has two axles, on which are placed motors of 135 horse-power. The motor has a total horse-power of 540, and is capable of a speed of about eight miles an hour when hauling a load. The overhead trolley system is used.

When engineers held the view that the water-tube boiler was necessarily a large consumer of coal, and therefore not an economical steam generator, there was a tendency to fit a combined arrangement in some warships, so that the ordinary cylindrical boiler could be used for steaming at low power, while the major portion of installation was of the water-tube type, so that not only could the full supply of steam be got with less weight, but it could on emergency be generated from cold boilers within a brief space of time. This idea found favor in France and in one or two other countries, but few carried it out. The Dutch, however, fitted some cruisers, and one of them has just completed her speed trials with very satisfactory results. The designed full power, as stated by the "Practical Engineer," was 9,000 I. H. P., but 10,000 horse power was exceeded on trial. Two cylindrical boilers weighing 120 tons were to give 2,000 horse power, and eight of Yarrow's boilers, weighing in all 90 tons, were to develop 7,000 horse power. As a matter of fact, the latter have given nearly four times the power of the former, so that, if measured by the respective weights, the water-tube boilers proved quite ten times more efficient than the old tank boilers.

Storage batteries have been in use on the Englewood & Chicago Electric Street Railway exclusively for slightly more than one year, and its cars have just completed 400,000 miles of service. It will be remembered that this road was built in the most solid and substantial manner expressly for storage battery work. Late in 1896, a few cars from the Madison Avenue (New York City) line were put in service, but it was not until January 1, 1897, that the first lot of new cars built expressly for the road, commenced running. This number was increased as rapidly as possible, and last summer, on the heaviest days, twenty 30-foot motor cars, each with a trailer, have been required. The company owns 44 sets of batteries, and up to the present time these batteries have averaged nearly 9,500 miles of service each, the maximum being about 13,500 miles. So far, there is no perceptible depreciation of the plates, and to all appearances they have yet a long lease of life. Nothing has been spent on maintenance account, according to the "Street Railway Journal," the Receiver, G. H. Condict, states that the entire operating expenses of the road in 1897 amount to but 8 cents per car mile, or 8½ cents including the expenses of the receivership. This is an extraordinarily low figure, even for a trolley line, and one which has never hitherto been approached in storage battery work. The cars run about 200 miles each per day, which is responsible for the low cost per car-mile of "car service" labor. Mr. Condict, who is most fair and conservative in his statements, is unwilling as yet to say positively that storage battery traction is on this road cheaper than the overhead system would be, but says that if the batteries, which, as before stated, are apparently in as good condition as when first installed, will last for 8,000 to 10,000 miles more, a distinct economy in comparison with the overhead system would be shown.

Personals.

Mr. William Voss has been appointed superintendent of the Ohio Falls Car Manufacturing Company

Mr. Benjamin Butterworth, United States Commissioner of Patents, died at Thomasville, Ga., Jan. 16.

Mr. Charles F. Means has been chosen to succeed the late Aureus Blood as agent of the Manchester Locomotive Works.

Mr. Menard K. Bowen was elected president of the Chicago City Railway Company, at the annual meeting held Jan. 15.

Mr. W. R. Ellis, formerly with the Pullman company, has been appointed superintendent of the Missouri Car Wheel Company.

Mr. G. H. Thomson, whose office is at 51 East 44th street, New York City, has been appointed Consulting Engineer to the Honduras Railroad Syndicate.

Mr. S. F. Forbes, general storekeeper of the Great Northern, has been appointed superintendent of car and machine shops of that road at St. Paul, Minn.

Mr. Edgar Van Etten, general superintendent of the New York Central & Hudson River, has been chosen president of the Randsburg Railway, of California.

Mr. S. W. Simonds has been appointed Road Foreman of Engines for the Shamokin Division of the Philadelphia & Reading, with headquarters at Shamokin, Pa.

Gouverneur Morris, the well-known civil engineer, who was for many years engaged in railway construction and coal mining operations, died at Detroit, Mich., December 30, aged 50 years.

Mr. Robert Gillham, general manager and chief engineer of the Kansas City Pittsburg & Gulf and controlled lines, has been elected a member of the Institution of Civil Engineers of England.

It is reported that Mr. E. W. Grieves, who recently resigned the important post of superintendent of the car department of the Baltimore & Ohio has accepted a position with the Galena Oil Works.

Mr. James Meehan has been appointed superintendent of motive power and machinery of the South Carolina & Georgia, with headquarters at Charleston, S. C., in place of Mr. J. H. Green, resigned.

Mr. Charles W. McMeekin, heretofore chief engineer of the Iowa Central at Marshalltown, Ia., has resigned his position to accept a similar position with the Anaconda Mining Company, Anaconda, Mont.

Mr. John McCormick, the oldest trainmaster on the Pennsylvania, died at his home in Altoona, Pa., Dec. 29, aged 70. He was made a trainmaster on the Pennsylvania in 1852, and was retired about a year ago.

Adams Earl, one of the projectors and the first president of the Lake Erie & Western, died at Lafayette, Ind., January 15, at the age of 78 years. He built the Lafayette & Chicago, now a part of the Big Four system.

Mr. T. O. Wood, general storekeeper of the Gulf, Colorado & Santa Fe, has been appointed purchasing agent of that road, with headquarters at Galveston, Tex., vice Mr. W. E. Hodges, general purchasing agent, resigned.

Mr. H. G. Burt, third vice-president of the Chicago & Northwestern, has been selected by the Reorganization Committee of the Union Pacific as president of the new company, and will have his headquarters at Omaha, Neb.

Mr. W. W. Rich, for many years chief engineer of the Minneapolis, St. Paul & Sault Ste. Marie, and formerly chief engineer

of the Wisconsin Central, has been appointed director-general of railways in China, and is now on his way to that country.

Mr. J. C. Yager has been appointed General Manager of the Wagner Palace Car Co., with office in New York City, vice J. A. Spoor, resigned, and Mr. W. O. Chase has been appointed General Superintendent, with office in Chicago, to succeed Mr. Yager.

Mr. S. W. Bretzfeld has been appointed eastern secretary, in charge of the eastern business, of the Pullman Palace Car Co. Mr. Bretzfeld has been connected with the New York office of the Pullman Co. for the past twenty-five years, and recently as Eastern purchasing agent.

Mr. David Sloan, since Aug. 1, 1897, acting chief engineer of the Illinois Central and Yazoo & Mississippi Valley, has been appointed chief engineer of those roads, with headquarters at Chicago. Mr. Sloan has been with Illinois Central since 1888, assistant chief engineer previous to last August.

Mr. F. Mertsheimer, superintendent of motive power and equipment of the Kansas City, Pittsburg & Gulf, has been appointed general superintendent. Mr. Mertsheimer was formerly division master mechanic on the Union Pacific, and went to the K., C., P. & G. as superintendent of motive power and equipment last summer.

Mr. J. C. Stuart, superintendent of the Galena division of the Chicago & Northwestern, has been appointed general superintendent of the Chicago, St. Paul, Minneapolis & Omaha, with headquarters at St. Paul, Minn. He has been superintendent of the Galena division since June, 1892, and was before that date for two years assistant superintendent of the Wisconsin division of the C. & N. W. From January, 1888, to June, 1890, he was chief dispatcher of the Wisconsin division.

Mr. Hiram R. McCullough, general traffic manager of the Chicago & Northwestern, was on January 4 made third vice-president of that road to succeed Mr. H. G. Burt, recently elected president of the Union Pacific. Mr. McCullough, who is 47 years of age entered railway service in October, 1876, and was for four years traveling auditor of the Illinois Central. In October, 1880, he took a position in the general freight department of the Chicago & Northwestern, and has been connected with that road ever since. He was appointed general freight agent in March, 1885, and held that position until he was made general traffic manager Oct. 1, 1896.

Mr. C. E. Barrett, who was formerly with the Missouri Car and Foundry Company, and who for the past four years has had charge of the car-seat business of Messrs. Hale & Kilburn, of Philadelphia, has been appointed contracting agent of the Barney & Smith Car Company, of Dayton, Ohio. Mr. Barrett, in connection with his new position, will push the sale of the Wheeler car seat, manufactured by the Barney & Smith people, and as he has been closely identified with the car-seat business for four years, we predict a largely increased sale for this seat, which is now the standard on many prominent railroads. The Barney & Smith Company are to be congratulated upon securing the services of Mr. Barrett, who is widely and favorably known among prominent railroad men.

Mr. John F. Wallace, who resigned as chief engineer of the Illinois Central Aug. 1, 1897, to accept the position of vice-president and general manager of the Mathieson Alkali Works, of Providence, R. I., has returned to the service of that road as assistant second vice-president, and assumed the duties of his new position January 1. The official circular announcing his appointment reads as follows: "Mr. J. F. Wallace is appointed assistant second vice-president of this company, with office at

Chicago, Ill. The second assistant vice-president will have general charge of maintenance of way and structure and also make investigations from time to time, under the direction of the second vice-president, as to the practicability of effecting economies in the service, and will perform such other duties as may be assigned to him by the second vice-president or the president. The chief engineer and consulting engineer will report to the assistant second vice-president."

We regret to announce the sudden death, on December 29, at Gloucester, England, of Mr. James Platt, the head of the firm of Felding & Platt, Limited, the well-known hydraulic machine-tool builders of that city. Mr. Platt was a member of the Council of the Institution of Mechanical Engineers, member of the Institution of Civil Engineers and also of the Iron and Steel Institute. He was vice-chairman of the Board of Directors of the Gloucester Railway, Carriage and Wagon Company, the largest and best-equipped car building establishment in England. James Platt was born in Manchester, England, on February 4, 1834. He was educated and served his apprenticeship in Sowerby Bridge, Yorkshire, where his father, Mr. John Platt, was the engineer and manager of the, at that time, celebrated tool builders, Francis Berry & Sons. In 1866 he founded the firm of Felding & Platt. In 1873 he took out, with Mr. R. H. Twaddell, the first patent on a hydraulic riveting machine. This was followed by many more, and since that date he has been closely identified with the development of hydraulic machine tools. It was he who saw the need of making riveting and flanging machines of heavy power to enable boilers to be built to stand the heavy pressure, then coming into use. His most important plant in this country is that of the hydraulic tools at the Juniata shop of the Pennsylvania Railroad at Altoona. The last piece of work he conceived and designed was the building of the gigantic gantry superstructure and riveting plant for Harlan & Wolff, of Belfast, now being used for the building of the large White Star steamship "Oceanic." With this plant practically every rivet in the ship will be put in by hydraulic power. Mr. Platt always took an active part in the work of the English engineering institutions and was a regular attendant at their meetings. Few men in the English engineering world will be so much missed, he having with his tactful and genial way made so many friends. His eldest son, Mr. John Platt, is now a resident of New York.

BOOKS RECEIVED.

"The 'Power' Catechism." Compiled from the Regular Issues of "Power." 266 pp., illustrated. Standard size, 6 by 9 inches. The Power Publishing Co., New York, 1897. Price, \$2.

This book contains questions and answers covering the subjects of steam engineering and the transmission of power. The arrangement of the information in the catechetical form was adopted because of its directness. It is used in the columns of "Power" because it appeals strongly to the practical man, who prefers a simple answer to a plain question to an elaborate discussion of principles. The demand for back numbers of the publication referred to led to the compilation of the information in book form, and for this purpose the matter was revised and extended. The preface states that the book is as complete as is consistent with the conciseness of this method of presentation. The subjects are as follows: Classification of boilers, boiler setting, boiler fittings and attachments, riveted joints, properties of steam, combustion and firing, boiler heating surface, safety valves, chimneys, steam piping, horse power of engines, the slide valve, the Corliss engine, engines in general, pulleys, belting, and shafting. The subjects are presented in a very concise form, and the statements seem to be well considered and reliable. It is intended for reference by those who have not the advantage of technical education, and who are not well versed in mathematics, but others will find it useful and valuable. It is well adapted to the use of those who have the care of steam engines and machinery, but it will also be at home among the books of well-informed engineers. The book is well printed and indexed.

"High Masonry Dams." By E. Sherman Gould, M. Am. Soc. C. E., Consulting Engineer for Water-works. Van Nostrand's Science Series, No. 22. D. Van Nostrand Co., New York, 1897. Price, 50 cents.

This work replaces the original No. 22 of Van Nostrand's Science Series, bearing the same title and written by Mr. John B. McMaster. The application of mathematics to this subject has been the means of introducing new methods of treatment, and the author has for a long time been convinced that it is useless to attempt to adhere to a general formula for a section of equal resistance. The basis upon which investigators of this subject have been working is a vertical section, the basis of which is a right-angled triangle, whose base is equal to two-thirds or three-quarters of the height as leading to a section of equal resistance. The author believes it wise to profit by the labors of those who have established this principle and would start his design by laying down such a triangle, giving it a practical top, in place of the theoretical apex. If the height of the dam exceeds from 80 to 100 feet, the inside face should be given a flare to increase the footing on the water side. The dangerous stresses in high dams are those of crushing, and this particular part of the designing is quite fully elaborated by the author. The maximum compressive stresses are determined at various heights in the structure with the assumptions of empty and full reservoirs, and if the sections are not satisfactory they are modified by taking account of practical considerations. After treating the theoretical side of the questions involved and establishing a practical section the author turns his attention to the execution of the work, including the necessary accessories to the dam. These features, such as spillways and waste culverts, are exceedingly important, as they have much to do with the safety of the structures, and the author's treatment appears to be able and clear. In the preface the author states that considerable additional information on the subject of dam and reservoir building is to be found in the second revised edition of the "Designing and Construction of Storage Reservoirs," which forms No. 6 of the present series. The work under review is divided into six chapters, as follows: Static stresses, unit stresses, unequally distributed unit stresses, the vertical section of high masonry dams, the construction of high masonry dams and accessories of dams. The volume is illustrated by clear diagrams, and the mathematical expressions are in simple terms.

"Report of the Tests of Metals and Other Materials for Industrial Purposes, made with the United States Testing Machine at Watertown Arsenal during the fiscal year ended June 30, 1896." Government Printing Office, 1897.

This report covers work done on gun specimens for departments of the Government and investigative tests for the Government and for private parties. Tests are recorded with reference to work on seacoast guns, and on the resistance of banded shell in rifled guns. Helical springs for 7 and 12-inch mortar carriages were tested, and considerable routine work for the Government departments was done. Among the interesting tests for private parties was a series on riveted joints for steam boilers and on bolted and riveted joints, used in building construction. These tests are recorded with special care, and they are accompanied by micrometer observations, showing the behavior of the joints in the tests. The examination of building materials was continued in the form of tests on building bricks, culvert pipes and timbers of Douglas fir and white oak. The impartiality of the testing gives the records a character which may be depended upon for accuracy and reliability. It is pleasing to note a very appreciative paragraph in the letter of transmittal, by Major J. W. Reilly, in regard to the work of Mr. J. E. Howard, C. E., who has had charge of the Watertown Arsenal testing machine since it was first installed. We are indebted to Major Reilly for a copy of the report.

"Year Book of Railway Literature, Vol. 1, 1897." Compiled by Harry Perry Robinson. The Railway Age, Chicago, 1897.

This book is the first volume of what is intended to be an annual publication putting into permanent form the addresses and articles that have appeared during the year upon the general subject of railroads. No originality is claimed for the work except that of having conceived the idea of compiling these papers and presenting them in a permanent and convenient form. This sort of literature is very valuable and heretofore it has been almost a hopeless task to search for

these articles which are from very different and widely separated sources. The subjects represented are chiefly those having to do with the most recent railroad troubles, such as are connected with pooling, the labor problem as related to railroads, rates taxes, railroad capital and kindred subjects. The chief object of the book is to render this mass of information easily accessible and to this end a very satisfactory index has been included. By saying that the work is a compilation we do not wish to intimate that it is the less valuable for that reason; we think that the editor, Mr. Robinson is entitled to credit for the idea, and also for the excellent manner in which it is carried out.

"Mechanical Draft—A Practical Treatise." B. F. Sturtevant Co., Jamaica Plain, Boston, Mass. Catalogue No. 98, 385 pages. Illustrated.

This book can not be too highly commended as a valuable publication for the use of those who have to do with steam boilers. One of its primary objects is to direct attention to the work of the Sturtevant Company, which it does in an admirable way. It goes much farther than that, and in really a valuable treatise on the subject of economical steam production in which the most important factors are the combination of fuel with oxygen itself, chiefly with the first of these factors, although considerable attention is given to steam engineering. One of the objects of the work is to present the advantages of mechanical draft, and to enable engineers to compare this with the chimney method by impartial statements. A secondary object is to show the adaptability of the Sturtevant fans. The matter is arranged with a view of rendering all necessary information available without consulting other works, and for this purpose chapters on water, steam and fuel were included. Where statements concerning the operation of the Sturtevant apparatus are given, references are included, and it is evident that special care has been taken to render the statements authoritative. The chapters in the book are as follows: Water, steam, combustion, fuels, efficiency of fuels, efficiency of steam boilers, rate of combustion, draft, chimney draft, mechanical draft, advantages of mechanical draft, the Sturtevant fans for mechanical draft, and the application of these fans. The book is the work of able engineers, who are close students of the subject, and the production is worthy of a place among the best volumes on steam making. It is well printed, handsomely illustrated and attractively bound.

"The St. Rolox Locomotive and Carriage Works of the Caledonian Railway." By Peter Livingston Dunn, Associate Member Institute of Civil Engineers (England).

This is a complete and interesting description of these important shops, including drawings of the plan and of sections of the important buildings. We are indebted to the author for a copy of the paper, which was read before the Institution of Civil Engineers in the session of 1896-1897. Mr. Dunn is now located in San Francisco.

"Proceedings of the Fifth Annual Convention of the Traveling Engineers' Association, held at Chicago, September, 1897." Edited by W. O. Thompson, Secretary, 1897.

The proceedings of this association are too well known to require more at our hands than a statement of the principal subjects of the reports and discussions recorded, which are as follows: The preparation of coal for use on locomotives. Is the brick arch an economical adjunct to a locomotive? Repairs and adjustment of air-brake equipment on the road, the Brown system of discipline, the operation of locomotive lubricators, locomotive operation as to use of steam, metallic packing, testing air brakes. These reports increase in value. The work of the association tends to improve methods of locomotive operation and the association merits encouragement, assistance and support.

"Interstate Commerce Commission." Ninth annual report of the statistics of Railways of the United States for the year ending June 30, 1896. Advance copy, without the six statistical tables. Prepared by the statistician to the Commission. Washington, Government Printing Office, 1897.

"Proceedings of the National Convention of Railroad Commissioners." Held at St. Louis, Mo., May 11 and 12, 1897. Government Printing Office, Washington, 1897.

"The Railroad Officials' Diary, 1898," is a standard size book with a page for each day of the year, each page being headed

with the date printed in bold type. The paper is good and also the binding, which is of flexible leather. The diary is sent with the compliments of the Railroad Car Journal, 132 Nassau street, New York.

"Third Annual Report of the Boston Transit Commission, for the year ending August 16, 1897."

"Mile a Minute Express Trains," by W. J. Scott. Allport Publishing Co., 79 Temple Chambers, London, E. C. 32 pp. Paper, price sixpence.

This is an account of fast trains, chiefly in England and is reprinted from "Cosmopolis," of August, 1897, with emendations and additions. It is illustrated.

"Annual Report of the Board of Regents of the Smithsonian Institution, Showing the Operation, Expenditures and Condition of the Institution to July, 1895." Government Printing Office, Washington, 1896.

Lambert Hoisting Engine Company.—A new catalogue (9¼ by 11¼ inches in size) has been received from this firm, who are manufacturers of hoisting engines and boilers, with works at Newark, N. J. The machinery shown in the pamphlet is specially intended for the use of those engaged in logging, mining, pile driving, dredging, quarrying, bridge erecting, coal handling by steam and electric hoists, and those requiring suspension cableways, traveling and stationary derricks. The managers and engineers of the Lambert Hoisting Engine Company have been identified with the design and manufacture of this special machinery ever since its inception, and they have had much to do with its development into the simple and efficient form of the present time. They have introduced the system of interchangeable construction as far as it is practicable to do so in this class of machinery, and men of experience know the value of avoiding vexatious delays which this system permits. The engravings shown in the pamphlet are taken from photographs of machines and therefore faithfully represent the product of these builders. The machines and boilers are tested at the works before shipment for the purpose of putting every machine or boiler into working order while yet in the hands of the builders. An important chapter in the catalogue explains the method of designing the parts of the machinery and gives an outline of the class of material used. The engravings throughout are excellent clear woodcuts, and no pains have been spared in giving the information needed by purchasers. This information is printed in large clear type and it appears upon the pages with the engravings, an excellent plan. The catalogue gives evidence of careful work and leaves the impression that this concern has not limited the work of its engineers. A copy of the catalogue should be obtained by everyone having to do with such machinery. The field covered is so wide that we have not space to mention the individual machines.

The Venturi Meter is described by text and illustrations in a standard size pamphlet of 38 pages recently issued by the Builders' Iron Foundry, Providence, R. I. This description presents the theory and practice of the subject, and is worthy of preservation by those who have occasion to measure quantities of liquids passing through pipes.

The Baldwin Locomotive Works have issued a valuable and attractive catalogue of narrow gauge locomotives. It contains a history of the Baldwin works, which is practically the history of the locomotive in this country. A circular stating the purposes of the volume follows the history, and under the caption "Class Designation" are a large number of vignettted half-tone engravings of narrow-gauge locomotives built by this company. Information as to weights and hauling capacity are given for each design. A chapter on compound locomotives illustrates and explains the Vaucrain system of compounding, and at the end of the book a large portion of space is given to locomotive details, in which locomotives and parts thereof are shown in simple line sketches with the parts numbered and listed to facilitate ordering for repairs. We must not omit to mention the general specifications for material as used by these builders. These are illustrated in detail by sketches. The book is handsomely illustrated; it is well printed and bound, and we are glad to have a copy upon our shelves.

"Key to Klondike."—In anticipation of a rush of business to the Klondike when the season opens the railroads interested are preparing their equipment and are providing facilities for

transportation. For the purpose of offering reliable information with regard to the country traversed, and the method of reaching the gold region, the Northern Pacific Railway sent a representative over the different routes and has embodied the information obtained in a folder entitled, "Key to Klondike," just issued by the passenger department. The folder gives a brief history of the Klondike, describes the region itself, the methods of mining, and gives distance and time-tables of the ocean and Yukon steamers, and those via Dyea and Chilkoot Pass. Two routes are shown from Unalaska, one via St. Michaels and the other via Sitka and Fort Selkirk. The inside of the folder bears a large colored map of Alaska, with the routes plainly indicated, and in one corner is a copy of the United States placer mining laws, with instructions for making claims and taking oaths. Besides this, the folder contains much interesting information, and a number of half-tone engravings, making it a publication worth sending for by those who go and those who do not. We are glad to have a copy of it for the information it contains. The folder will be sent to any address upon application, enclosing a 2-cent stamp, to Mr. Charles S. Fee, General Passenger and Ticket Agent, Northern Pacific Railway, St. Paul, Minn.

Hilles & Jones Company, Wilmington, Del., Catalogue "O" of Machine Tools. This is a pamphlet, standard size (9 by 12 inches) of 44 pages, well illustrated with half-tone engravings. The field covered is that of the machinery required by boiler makers, bridge, car, locomotive and iron ship builders and workers of plates, bars and structural shapes. The machines illustrated are: Punches, shears, combined punches and shears, multiple punches, gate shears, special punches for fish plates, bevelling shears, angle and channel straighteners, plate bending and plate straightening rolls, plate planers, vertical milling machines, riveting presses, I beam shears and coping machines and benders for I beams and channels. These machines are driven by direct connected steam engines or electric motors. They are also arranged for attachment of pulleys for belt driving. The pamphlet is not intended as a general catalogue. It presents a few of the recent designs of this firm, and exhibits the class of machinery built by them. The range of the machinery both as to character and size is wide, and it is evident that this concern has devoted a great deal of attention to the production of powerful, convenient and efficient machinery of this class.

"Endorsements of the Civil Engineering Courses of the International Correspondence Schools."—The International Correspondence Schools of Scranton, Pa., have issued a small 64-page pamphlet containing endorsements of the schools from 64 students in civil engineering. These come from 24 States and from Canada, and from them an excellent idea of the high opinion of the schools from those best able to express opinions may be had.

"Pocket Manual of its Stocks Which Paid Dividends in 1897." This is a small pamphlet giving a list of the stocks listed on the Boston and New York Stock Exchanges, with the par value of each, and the dividends paid in 1897. It is indexed and will be valuable for reference by the holders of these securities. A copy will be sent on receipt of a two-cent stamp by Leland Towle & Co., bankers and brokers, 7 Congress street, Boston.

The American Railway Electric Light Company, of 14 Stone street, New York, have issued an illustrated catalogue describing the automatic railroad and house lighting systems, employing electricity as installed by them.

MALLEABLE IRON BRAKE FORKS.

The brake fork shown in the accompanying engravings was invented some time ago by Mr. T. W. Kelly of the Duluth, South Shore & Atlantic Railway, the chief object of the design being to provide a substitute for wrought iron forks, which should be at once strong and inexpensive. They are made of malleable iron by the Dayton Malleable Iron Company of Dayton, Ohio. They have been tested by a pulling stress of 40,000 pounds without fracture, which is satisfactory evidence that the design is good. There is no weld in the fork, and none in the rod with which it is connected, the

ends of the rods being upset to form a bearing in the fork as shown in the engravings. These forks are sold at a very low price, which is stated to be less than one-half the price of those of wrought iron.

Several years ago, Mr. J. J. Connolly, Master Mechanic of the road referred to, wrote the following in a letter describing his experience with these forks: "The brake fork invented by Mr. Kelly and made in malleable iron has been in use on 30¢ cars on this road, and we have never had a single failure—they have been tested with a pulling strain of 18 tons without a failure. They can be made for about one-half the cost of the wrought-iron fork, which should be quite an advantage to railroad companies and car manufacturers."

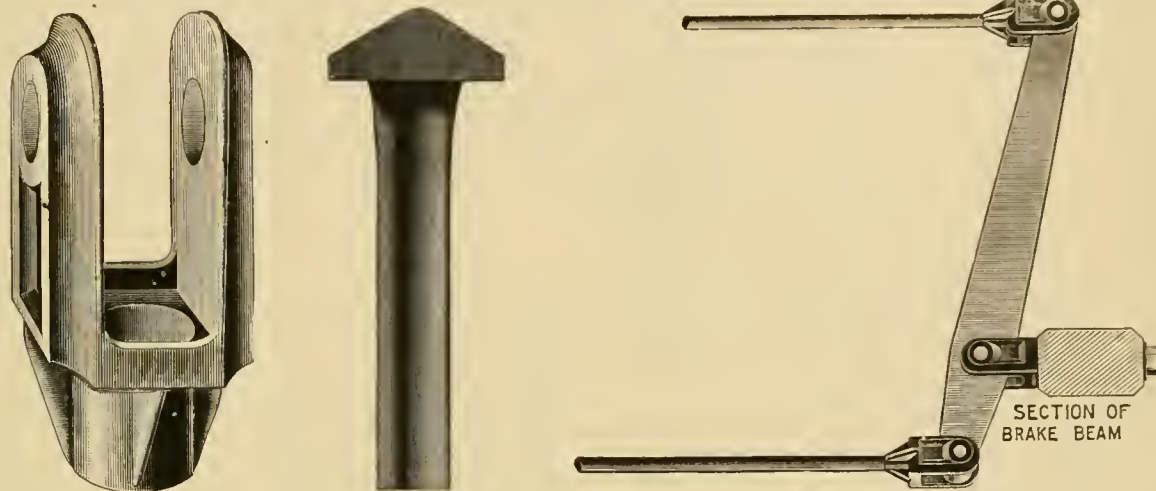

The Kelly Malleable Iron Brake Fork.

Mr. Kelly recently wrote us to the effect that the report by Mr. Connolly has been fully sustained and the opinion then formed has not been changed. The device has been adopted on twenty-five railroads, among which are several of the leading lines in the United States. Mr. Kelly considers the fact that the rod may be made complete without a weld, by merely upsetting the end in a hot machine, as one of the important advantages which it possesses over wrought-iron forks. The illustrations show the method of using the forks. The head on the end of the 3/4-inch rod is upset with a bevel, the large diameter of which is 15-16 inch under the head. The engraving shows the use made of the two styles of forks.

by the engine and train crews, because the advantages of the "personal interest" element in those good old days were possibly mutual as between shipper and crew, as well as between shipper and the railroad company. Regardless of whatever there may have been in such claims, however, the change came about, as such changes usually do, as a matter of necessity. The changed conditions seemed to meet all the requirements for many years, because the result was a largely increased output for each machine, the output being then limited by the endurance of the engine crews. The crews were too often either tempted or urged beyond the proper limit of endurance, and the results were disastrous, as is only too well known by many.

The extra list was created as a necessity, with a view to still further increasing the output of each machine, and averting the danger of overworking the engine crews. The result was quite satisfactory, in so far as there was removed the necessity of urging the crews beyond their proper limit of endurance;

but the temptation, in the form of increased earnings, to overreach this limit still remained. It was still evident that too much money was invested in locomotives that were occupying stalls in round-houses when they should have been moving traffic. In order to further obviate this trouble, many experiments have been made to place two crews on each locomotive, but, except on roads where the volume of business is somewhat uniform, this system has been found unwieldy in freight service, and on lines where there is a wide fluctuation in business at different seasons of the year, its lack of flexibility seems to render it quite impracticable.

Another system of handling engine crews has been tried; it is what is known as "pooling," in which the number of engine crews assigned to a particular division, district or territory, is in excess of the number of engines. In this system the crews run, "first in, first out," without any reference to the engines to which they may be assigned for each, or for any, trip, and the engines are assigned to meet the needs of the traffic only, and quite untrammelled by any rules established to conserve the so-called "rights" of this or that man. The idea of this arrangement is to keep the engines in constant service, barring necessary repairs, and at all times to have them manned with crews that have had opportunity to secure required rest; and to regulate the number of engines and crews to meet the demands of the business so that the engines in actual service will be worked up to their capacity, and those not needed during seasons of light business may be laid up ready for any emergency. The number of crews assigned is such that they may at all times have ample rest before going out on the road, and also that they may earn a somewhat uniform rate of pay. The system is one which seems to afford sufficient flexibility to cover almost any range of fluctuation in the volume of business.

It would seem fair to assume that the best evidence of the worth, or unworthiness of this system would be the testimony of those who have tried it; and I will, therefore, beg the privilege of submitting such evidence; what follows will be based largely upon this testimony.

The letters are not reproduced here. They corroborate the statements of the author, and coming from three superintendents, two master mechanics and an engineman, a fair view of the subject is presented.

Such is the testimony—not of men who have tried it as an experiment for six months, a year, or even two years, but of men who have tested the pooling system eight or ten years as superintendents, master mechanics, engineers and foremen and after an experience extending over eight or nine years at two different points, I cannot do otherwise than emphasize what they have said. Perhaps the best way to do this is

POOLING LOCOMOTIVES AND LOCOMOTIVE CREWS.*

Mr. J. F. Deems.

In the earlier days of railroading, it was the practice to assign regular engines, engine crews and train crews to all trains, in both freight and passenger service, and it was thought to be impracticable to handle the business in any other way.

This practice prevailed in some places to a considerable extent as late as 1871. It must be evident that under this system, unless the train schedules were arranged with special preference to the convenience of the locomotive department, rather than the commercial interests of the road, the earning power of locomotives might have been very limited. With the extension of railroad lines, and the increase of traffic, this method was found to be expensive and unwieldy, and as other improved facilities, chief of which was the telegraphic train dispatching, came into use, it was superseded by the system quite generally in vogue at the present time, in a modified form. The aim of the present system is to keep certain engines and engine crews together, without any reference to the trains they may haul. It is said that when this change was first suggested, it met with strong opposition from the traffic officials, who urged that it would result in much confusion on account of constant changing of crews and a direct loss in revenue due to the "personal influence" of the regular crews, where business was handled day after day by the same crew for the same shipper. This view was doubtless concurred in

*From a paper read before the Western Railway Club, December, 1897.

to quote some figures which were prepared for another occasion:

Year.	System of operation.	Cost per Mile.					
		Small store.	Waste oil and tallow.	Fuel.	Wages.	Repairs.	Total.
1890....	{ Regular Crews }	.08	.28	6.51	6.65	4.97	18.49
1893....	Pool	.10	.25	6.56	6.58	4.86	18.37

I would say in regard to these figures, that all the conditions for the two periods given were identical, with the exception that crews were assigned to certain engines, and in this case the pools had not been in operation long enough to be working properly. It showed much better results later on.

The testimony seems to show about as follows: First—It is possible to get greater mileage with the engines in a pool than under the regular crew system. Second—A given amount of work can be done with 20 per cent fewer engines under the pooling system than when regular crews are assigned to the engines. Third—An engine in the pool will haul heavier trains than in the regular crew system. Fourth—Both the cost of repairs and service per mile and mileage of engines between shopping periods show in favor of the pool. Fifth—The advantages of the pool are mutual as between the railroad and the enginemen.

I will pass the first proposition and deal with the second, as they are so closely related that the first is doubtless absorbed in the second. Assuming that a road requires 500 engines under the old system to do a given business. If it is possible to do the work with 400, there is a direct saving of say \$950,000 to start with, which at 6 per cent interest represents an annual saving of \$57,000, to say nothing of less room required to house the engines and the reduction in other incidental expenses. The third claim, that pooled engines will move heavier trains, is not as susceptible of demonstration as the second, but it seems to be amply supported by the testimony, especially by that of the superintendents, but possibly this is also absorbed or included in the second claim.

The evidence of the fourth proposition, concerning the cost of repairs and mileage between shopping periods, I believe cannot be successfully contradicted, and will be corroborated if the pooling system has been in force long enough to get working properly; at least my experience of nine or ten years with both systems convinces me that the statement is correct.

As to the fifth point, about the pooling system being of as much advantage to the enginemen as to the railroad company; this will probably be doubted by those who have not given the pool a thorough test, but I am sure it will be concurred in by those who have given it a thorough test.

How should such a pool be organized and operated? First, there must be the enthusiastic support of every foreman and officer who has anything to do with organizing the pool, in order to develop, as far as possible, a sentiment among the enginemen in its favor; or, at least, to allay the opposition that must be expected. The officers can profitably make a special effort to do everything possible that will add to the comfort of the enginemen, and thus contribute to overcoming this prejudice. Supposing that for a certain division forty engines are required to handle the business. A sufficient number of crews should be assigned to insure every man an opportunity to get proper rest between trips. The number will, of course, have to be adjusted from time to time, to meet fluctuations in business, and it is this elasticity of the pooling system that adapts it so perfectly to the varying conditions of traffic. Enginemen and firemen should be assigned together and kept together just as though they were on regular engines. In some instances where no attempt has been made to do this, the results have not been satisfactory.

An extra list of engineers and firemen should be carried at the home division point, the same as if a "regular engine" system prevailed, so that if a man for any reason fails to go out in "his turn" an extra man can be put in the place. The regular man then waits until his turn has come again before he is "marked up" for duty, just as he would wait for "his" engine under the regular crew system.

By providing each crew (not each engine) with a suitable set of oilers, a complete check can be kept and as good mileage for oil can be made as with regular engines; these oil-cans may be left in the oil-house at the end of each trip, as is now done in some places where the regular crew system prevails. The writer can cite an instance where a division is handled under the regular crew system and an adjoining one under the pool, and the latter has shown the best oil performance month after month, the conditions being such as to make the work fairly comparable. The same is true of the fuel record.

As to the cleaning and care of engines by firemen. There seems to be no reason why firemen should be excused from this duty in the pool any more than with regular engines, providing that in either case the engine lays at a terminal long enough to receive such care. All that is necessary is to exercise care in "marking up" the engines as soon as possible so that each fireman may know what engine to care for; in case any change is made in the assignment that requires him to clean more than one engine for any one trip, he should be paid for the extra work. This has been practiced for more than two years with entire satisfaction, by paying the fireman sixty cents for each extra engine cleaned.

It may be found necessary and profitable to employ engine inspectors at principal division points where engines are pooled,

and such men, if adapted to their work, can make themselves very valuable by making many light repairs; but there are instances where a pool has been run with entire success, at a point where there were from thirty to fifty engine arrivals per day and no engine inspectors were employed.

It seems to be the generally accepted theory at the present time, that the best results are obtained where it is possible to keep the engines constantly in service; this being true, it seems strange that during periods of dull business, more attention has not been given to the idea of laying up, in good condition, such engines as could be spared from service and thus keep the others in more constant use; there is little doubt that in this there is an opportunity for considerable saving, and there seems to be no way in which it can be accomplished so satisfactorily as in a pool. With the modern locomotive, equipped with solid bushed side-rods and, in some cases, main rods of the same design, with metallic steam packing at every joint, in many instances with fixed driving box wedges or liners, there seems to be no valid reason why this cannot be done with great profit.

In conclusion, I think there are few who will not agree that in years gone by locomotives were pointed to with much pride, merely as marvels of mechanism, with very limited comment on the maximum earning power of the same; but the time has come when more attention must be given to the service of the machine and less to the machine itself, merely as a machine, and possibly with more study of the pooling system it may prove a means to that end.

DURATION OF LOCOMOTIVE BOILER TESTS.

Among the written discussions submitted at the recent meeting of the American Society of Mechanical Engineers upon "The Draft of the Report of the Committee on the Revision of the Society Code of 1885, Relative to a Standard Method of Conducting Steam Boiler Trials," which were presented by title only at the meeting, was one by Professor Goss of Purdue University, which deals with a phase of the general subject which cannot fail to be of interest to locomotive men. It is as follows:

It is with some hesitation that I enter upon a discussion of a document which is the result of so much consideration as the report of this committee. It contains, however, one specification, the wisdom of which, I venture to call in question. It is that "A test should last at least 10 hours of continuous running."

I assume that this specification is intended as a safeguard against errors which are likely to appear in results derived from very short tests, and I am in sympathy with the purpose which the committee evidently had in mind in proposing it, but there are many boilers working under forced draft from which, I believe, good results may be obtained by a test of less than 10 hours' duration.

There are but two purposes to be served in prolonging a test after it has been well started; the first is to reduce the effect of the unavoidable errors incident to the starting and stopping; and the second is to allow the observations to cover so thoroughly the fluctuations in the water level, temperature of feed, steam pressure, rate of evaporation, and fire condition, that the average of the observations may be assumed to represent the average condition existing upon the boiler for the test. Errors of the first class are by far the most important, and where the conditions are favorable to the work of testing, they constitute the only ones which need be seriously considered as affecting the duration of a test. But for any given boiler, the effect of errors incident to starting and stopping is approximately proportional to the totals of the test; the effect upon the final results will not be proportional to the duration of the test, unless the rate of evaporation is always the same. With reference to this proposition, I will say that errors due to starting and stopping are likely to be somewhat larger for a boiler under high power, than for the same boiler when it is working light. Otherwise the effect of such errors would be strictly proportional to the totals of the test; but the increase in the chances of error accompanying the increase of power is not so great as to impair the value of the statement just made.

Increasing the power of the boiler, therefore, justifies a reduction in the duration of a test, because by increasing the power, the rates of evaporation and the rates of combustion are increased. Where forced draft is used, these rates become so enormously high that the tests may be made very short.

From these considerations it will appear that if other conditions are the same for each test in any given series of tests the relative degree of accuracy of the several tests becomes a function not only of duration, but of the other variables as well. Two tests, therefore, may vary greatly in duration and yet yield results having the same degree of reliability. Again, it is sometimes a fact that differences in duration are of less consequence than differences in the rate of evaporation or in the rate of combustion. In such cases the safeguard if placed on the duration, as proposed, depends upon a factor which is not of the first importance.

I present herewith for purposes of comparison, certain data, derived from a horizontal tubular boiler, and from a locomotive boiler having approximately the same extent of heating

and of grate surface. The facts concerning the tubular boiler have been selected from "Boiler Tests" by Barrus (No. 41, page 160), and those concerning the locomotive boiler have been taken from the records of the Engineering Laboratory of Purdue University.

	Tubular Boiler. (Barrus.)	Locomotive Boiler. (Purdue.)
Heating surface.....	1,221	1,347
Grate surface.....	20	17.5
Duration of test.....	12	3
Total water evaporated for test.....	19,991	34,324
Total coal fired for test.....	1,912	5,933
Water evaporated per foot of heating surface per hour.....	1.4	8.4
Coal fired per foot of grate surface per hour.....	8	113

Under the proposed code, the results from the tubular boiler would be accepted without question, the conditions being normal in all respects, and the duration of the test exceeding by two hours the minimum prescribed; while those from the locomotive boiler would as certainly be thrown out, the test having been run for less than one-third the minimum time prescribed.

But if judgment is based upon the totals from the test, the results from the locomotive boiler should be accepted. For this boiler the rate of evaporation per foot of heating surface was six times greater, and the rate of combustion per foot of grate surface, 14 times greater than the similar values for the tubular boiler. The totals of water and fuel for the test are far larger for the locomotive boiler than for the tubular boiler, and it has already been shown that the relative degree of reliability, other things being equal, is approximately proportional to the totals, so that with the same care exercised in each case the test of the locomotive boiler is the more reliable of the two, notwithstanding the fact that its duration is only one-fourth that of the tubular boiler, and notwithstanding the fact also that it is seven hours too short to pass muster under the proposed code.

It is not my purpose to argue in favor of a general reduction in the duration of boiler tests. I should oppose such a proposition. But I also believe that conditions are sometimes found which make a test of ten hours unreasonably long. It seems to me, therefore, that the minimum requirement should not be based directly on the length of time, but upon the quantity of water evaporated and the amount of coal burned.

I should, therefore, be glad to see substituted for the clause in the proposed code reading: "A test should last ten hours of continuous running," the following: "A test should last a sufficient time to give an equivalent evaporation of not less than 15 pounds of water per square foot of heating surface, and a combustion of not less than 100 pounds of dry coal per foot of grate."

A specification in this form would meet the requirements of the case, and would be more logical than that which is proposed by the committee. For conditions common to practice with stationary boilers, the values given make the requirements which I propose, very nearly the equivalent of that which is proposed by the committee.

NEW TEN-WHEEL LOCOMOTIVES—NORTHERN PACIFIC RAILWAY.

Last month we noted the fact that the Northern Pacific Railway had ordered a number of locomotives from the Schenectady Locomotive Works. We have received tables of dimensions from Mr. E. M. Herr, Superintendent of Motive Power of the road, which are printed below. There are 24 engines in all, eight being freight compounds, eight passenger compounds and eight passenger simples. By comparison with the dimensions of the earlier engines of these types ordered of the same builders last year, and described in our issue of April, 1897, page 113, and June, 1897, page 185, it will be noted that the new ones will be almost exactly like the earlier ones, both as to freight and passenger types. The new freight engines will weigh 2,000 pounds more, the high pressure cylinders will be one inch larger in diameter and the stroke will be increased from 26 to 28 inches, but otherwise the changes are unimportant. These slight changes in the freight engines and the almost exact reproduction of the passenger engines indicate that the earlier designs must have been found satisfactory in service, and this accords with reports which we have received as to their operation.

The driving-wheel centers of the new engines are of cast steel, while the engine and tender truck wheels are the Standard wrought plate, with Northern Pacific retaining rings. The Westinghouse automatic air brake is fitted to all of the tenders, and the American brake to all of the driving wheels. All of the engines are equipped with the Westinghouse air

train signal. The most important characteristics of the designs are given in the following table:

Type	Freight Compound. 10 wheel	Passenger Simple. 10 wheel.	Passenger Compound. 10 wheel.
Number ordered.....	8	8	8
Class.....	"S"	"P"	"P Compound"
Cylinders.....	23 and 31 by 28 in.	26 by 26 in.	22 and 31 by 26 in.
Driving wheels.....	63 in. dia.	69 in.	69 in.
Wheel base, total..	26 ft. 3 in.	25 ft. 19 in.	25 ft. 10 in.
Wheel base, driving	14 ft. 10 in.	14 ft. 10 in.	14 ft. 10 in.
Wheel base, total..	52 ft. 9½ in.	52 ft. 2 in.	52 ft. 2 in.
Weight on drivers..	126,000 lbs.	112,000 lbs.	112,000 lbs.
Weight on truck...	48,500 lbs.	28,600 lbs.	43,500 lbs.
Weight, total.....	174,500 lbs.	150,600 lbs.	155,500 lbs.
Weight, tender empty	37,800 lbs.	39,600 lbs.	39,600 lbs.
Weight, tender loaded	92,030 lbs.	94,000 lbs.	94,000 lbs.
Length over couplings.....	60 feet.	59 ft. 1 in.	59 ft. 1 in.
Height of stack....	14 ft. 10½ in. extended wagon top.	14 ft. 3¾ in. extended wagon top.	14 ft. 9¾ in. extended wagon top.
Boiler, diam. smoke box.....	70 in.	62 in.	62 in.
Firebox, length.....	120 in.	108 in.	108 in.
Firebox, width.....	41 in.	41 in.	41 in.
Firebox, depth front	84 in.	76 in.	76 in.
Firebox, depth, back	71½ in.	64 in.	64 in.
Tubes, number....	376	314	314
Tubes, diam. of....	2 inches.	2 inches.	2 inches.
Tubes, length....	13 ft. 10 in.	14 ft.	14 ft.
Heating surface—			
Firebox.....	208 sq. ft.	168.03 sq. ft.	168.03 sq. ft.
Tubes.....	2,687.5 sq. ft.	2,316.97 sq. ft.	2,316.97 sq. ft.
Total.....	2,895.5 sq. ft.	2,485 sq. ft.	2,485 sq. ft.
Tender, water capacity.....	4,350 gals.	4,350 gals.	4,350 gals.
Tender, coal capacity.....	9 tons.	9 tons.	9 tons.

The following special attachments are provided for the freight engines: Jerome metallic packing, springs by A. French & Co.; crank pins nickel steel, magnesia sectional boiler lagging, McIntosh blow-off cocks, Ashton safety valves, pneumatic sand feeding apparatus, Golmar bell ringer, M. C. B. coupler on tender, Kewanee brake beams, Allen American balanced valves, and on the passenger engines the following are used: Jerome metallic packing, springs by A. French Co., crank pins nickel steel, magnesia sectional boiler lagging, McIntosh blow-off cocks, Ashton safety valves, pneumatic sand feeding apparatus, Golmar bell ringer, Kewanee brake beams, Consolidated steam heat apparatus, Mason reducing valves, Allen American balanced valves.

TONNAGE RATING.

In a paper read at the last meeting of the New York Railroad Club, Mr. L. R. Pomeroy presented an excellent, comprehensive review of the subject of tonnage rating of locomotives, which may be spoken of as having two principal objects, the first of which is to show how the rating of a locomotive on the tonnage basis may be intelligently and correctly obtained, and the other is to show how the rating should be applied in practice after it has been established. Those who are seeking a clear and concise treatment of tonnage rating will do well to read the paper.

The author divided the subject into five parts. In the first he shows that loading or rating locomotives on the car basis is unsatisfactory, because of the great variation in the loading of cars. He next demonstrates by practical examples that rating locomotives on tonnage basis is both practical and satisfactory. The third subject is the hauling capacity of locomotives. After treating of the cylinder power of the engine in its relation to the load hauled, he discusses the effect of grades, velocity and kinetic energy of trains in climbing them. This part of the paper is summed up as follows:

1st. Determine the number of tons each class of engine is capable of handling in each direction over all ruling grades.

2d. Tests to be made under the most favorable circumstances, i. e., favorable weather and dry rail; the results so established, to be considered the maximum capacity of the engines, and to be considered as No. 1 rating.

3d. Provide for inferior rail, unfavorable and stormy weather, establish No. 2 and 3 ratings. This is to be done by actual tests and approximates, the results will be about as follows:

No. 2 rating equal 90 per cent. of No. 1.

No. 3 rating equal 80 per cent. of No. 2.

To the discretion of the dispatcher who receives a telegraphic report of the weather and condition of rail from all stations twice a day, is left the decision as to whether a train shall be made up to first, second or third rating, the yardmaster having standing orders to load all trains to first rating in the

absence of other instructions. There are certain exceptions, however, in the case of fast time freight and stock trains, which uniformly receive second and third rating.

Variations and Ratings to Meet Climatic and Mechanical Variables, Established and in Use on the Col. H. V. & T. R. R.

Thermometer.	Class "A" rating	Class "B" rating	Class "C" rating	Class "D" rating
1. 40° and above.....		94% of "A"	94% of "B"	93% of "C"
2. Bet. 30° and 40° +	94% of No. 1	94% of No. 1	94% of No. 1	94% of No. 1
3. Bet. 20° and 30° +	94% of No. 2	94% of No. 2	94% of No. 2	94% of No. 2
4. Bet. 10° and 20° +	93% of No. 3	93% of No. 3	93% of No. 3	93% of No. 3
5. Bet. 0° and 10° +	93% of No. 4	93% of No. 4	93% of No. 4	93% of No. 4
6. Bet. 0° and 10° -	85% of No. 5	85% of No. 5	85% of No. 5	85% of No. 5
7. Bet. 10° and 20° -	91% of No. 6	91% of No. 6	91% of No. 6	91% of No. 6

Class "A"—Engine out of shop 9 months.
 " "B"— " " 9 to 12 months.
 " "C"— " " 12 to 15 "
 " "D"— " " over 15 "

The weight of cars and methods of ascertaining them are then discussed, and the author proceeds to the most important division of the subject, "Making up Trains." He says in part:

Having established the engine ratings, and inaugurated a system of reporting car weights, the next point is the making up of trains. When the train is composed wholly of loaded cars, the operation is obviously simple. But when empty cars are indiscriminately sandwiched in with the "loads," we are then confronted with the "variables" of the problem. Tests

total resistance, and hence gross weight of trains, on any two rates of grade, will be as the rate of grade per cent. plus 0.3. On grades of 0.5 and 1.0 per cent. adding 0.3 to each, we have 0.8 and 1.3 as the equivalent gradient in each case, including the rolling friction. The gross weight of trains, on these grades, will be as 0.8 is to 1.3 or 1 to 1.625 and not as 0.5 to 1 or 1 to 2, consequently as the grades are higher the comparative gross weight of trains comes nearer and nearer to the grade resistance only, as is but natural, since the rolling friction becomes less and less an important fraction of the total resistance?

If the rolling friction for loaded cars is equal to 6 pounds per ton, and that of empty cars is 30 per cent. greater, then on a level the ratio is as 6 to 7.8. But on a grade the resistance due to gravity being common to both empty and loaded cars, the ratio becomes: As the [(grade % × 20) + 6] is to [(grade % × 20) + 7.8] or for a 1 per cent. grade, as 26 is to 27.8 (or 1:1.07) and not as 6 is to 7.8 (or 1:1.30).

A chart, Fig. 1, somewhat on the foregoing lines, has been worked out by Mr. Tracy Lyon, Master Mechanic of the Chicago Great Western Railway, which is intended to show at a glance the amount of deduction from the rating for each empty car, varying as the ratings of the several classes of engines change, from high to low ratings; being greater for a high rating than for a low one, as the lower the rating for any given engine, the greater the grade is assumed to be that produces this lower rating. This, in the writer's opinion, is a much simpler form than the Northern Pacific Railroad chart, as such

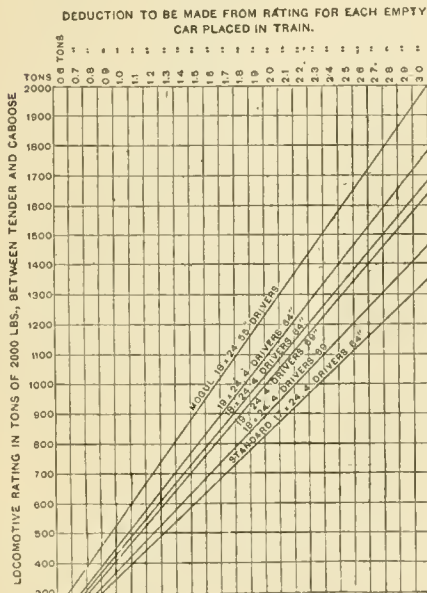

FIG. 1.

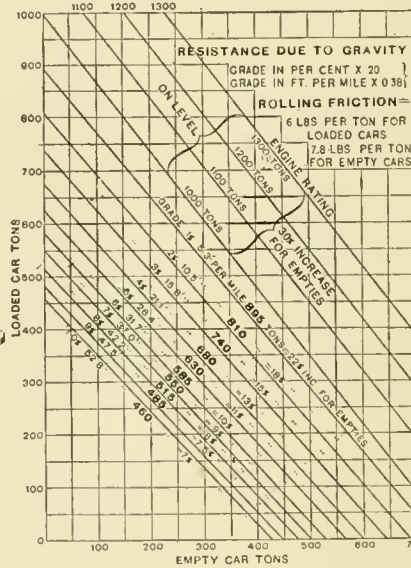

FIG. 2.

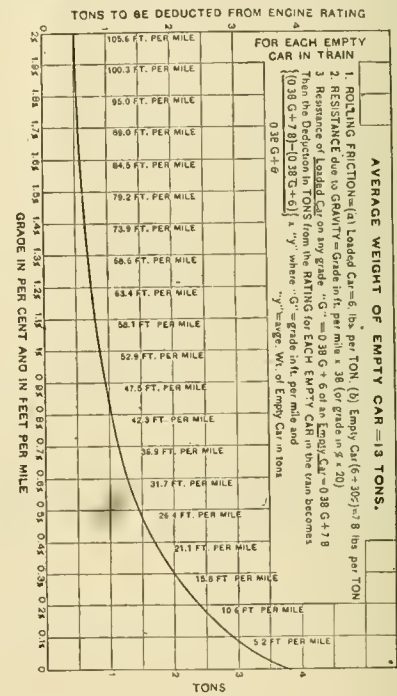

FIG. 3.

made on a certain division of one road, showed that the maximum train-load, when composed of loaded cars, was 750 tons; and when composed of empty cars, 650 tons. In both cases, care was exercised to pick out such representative loaded and empty cars as would fairly meet average conditions. It was also found that the number of cars in the train composed wholly of empty cars, exceeded that of the loaded car train by 20 cars.

The power of the engine, in each case being the same, it was assumed that the difference in the number of tons hauled (100) was due to the resistance of the increased number of cars in the "empty" train, namely, 20 cars. Dividing the 100 tons by the 20 cars, we get 5 tons as a quotient. This was assumed to represent the resistance of each car, whether loaded or empty. The real load of the empty car train then becomes: 50 cars, 13 tons each, plus 5 tons, the assumed resistance of each car, making 18 tons per car, or a total of 900 tons. On the same basis the loaded car train composed of 30 cars of 25 tons each becomes by adding 5 tons to each car, as above, 900 tons, or the same weight as that of the empty car train. This 900 tons is called the "basis of loading" and the yardmasters are instructed to load trains to 900 tons, including weight of load and car; five tons to be added to each car in the train so made up. It is claimed that this manner of loading not only allows for empty and loaded cars, but also for partially loaded cars.

The basis of loading, i. e., 900 tons, and the resistance per car, 5 tons, varies with the physical conditions of the road, necessitating similar trials for other divisions where the conditions differ.

Many plans in use, assume the resistance per ton, on a level, for empty cars, due to rolling friction, to be 30 per cent. greater than that for loaded cars.

Taking the rolling friction at ordinary freight-train speeds at 6 pounds per ton (equivalent to a 3 per cent. grade), the

a form will cover all the conditions of the road.

Fig. 2 is submitted in the line of a modification of the form used by the Northern Pacific Railway, by providing a diagram for each class of engine, rather than for every change in the physical conditions; the writer assuming that on most roads, at least, there would be fewer classes of engines than varieties of physical conditions. The diagram is worked out on the following plan:

Assuming a rating, the amount to be added to the empty car tonnage to equalize the increased resistance per ton of empty cars would be as follows:

On a level add.....	30 per cent
" 1 per cent. grade 5.3 feet per M. add.....	22 "
" 2 " " " 10.5 " "	18 "
" 3 " " " 15.8 " "	15 "
" 4 " " " 21.1 " "	13 "
" 5 " " " 26.4 " "	11 "
" 6 " " " 31.7 " "	10 "
" 7 " " " 37.0 " "	9 "
" 8 " " " 42.2 " "	8 "
" 9 " " " 47.5 " "	7.5 "
" 10 " " " 52.8 " "	7 "

To illustrate the method of loading by the diagram let us assume first, a 1 per cent. grade (52.8 feet per mile); second, an engine rated at 460 tons; third, 300 tons of empty cars to be hauled. Query: How many tons of loads can this engine take with 300 tons of empties? As in Fig. 2 the horizontal lines represent "loaded" car-tons, and the verticals "empty" car-tons, we then follow the line at the bottom of the diagram, representing "empty car-tons" until we find 300; follow up the vertical, opposite 300, until it touches the diagonal corresponding with the rating "460," the nearest horizontal line coinciding with the vertical (300) and the diagonal (460) is 140, which shows that this particular engine can haul 300 tons of empties and 140 tons

of "loads" under the conditions described. By calculation we have 460—(300 plus 7 per cent.) equals 139.

Fig. 3 represents an effort to still further simplify the problem. It is supposed to provide one form of diagram for all conditions, but doing away with the diagonal lines which represent different classes of engines. We have assumed the average weight of empty cars to be 13 tons. On this basis the number of tons to be deducted from any rating for each empty car in the train, for any conditions, from a level to a 2 per cent. grade, can be read off on the left of the diagram. Of course 13 tons is an arbitrary weight, but any other factor can be chosen or several curves can be plotted on the same diagram representing 11, 13, 15 or any other number of tons.

THE BRACKIN PIPE WRENCH.

The Brackin Manufacturing Company, of Cleveland, O., are placing a new pipe wrench on the market. The construction and operation of the wrench are shown in the accompanying illustrations, of which one shows the tool complete, the other shows four working parts, indicating the distribution of their strains. One of the objects of this invention is to provide a pipe wrench having a stationary jaw with a yoke firmly secured thereto and provided with a movable drop jaw so constructed that the fulcrum of bearing of the movable jaw will occur at that point of the wrench where the stock is the strongest. The makers in constructing this new tool for its special work have made durability and strength a prime feature. The jaws and pawl are drop forged from tool steel, special attention being given to tempering. The yoke and



The Brackin Pipe Wrench.

lever are drop forged from machinery steel. The surface of the lever which comes in contact with the end of the pawl is case-hardened, and the fulcrum rivet, in the under side of the arched portion of the yoke, is tempered.

The method of construction, together with care in manufacture, form the basis for the claim that this wrench will work satisfactorily without locking upon or crushing the pipe. The parts are simple, few in number and accurate in operation. Adjustment is readily made. By means of the pawl thumb piece, the teeth are disengaged, and the jaw being released can easily be moved in or out. To operate in close quarters or to adjust for a small pipe, it is only necessary to push on the lever, resting the jaw on the floor or against the pipe, when it adjusts by the ratchet movement. This method shows how easily the wrench can be used with one hand. The object of the pawl thumb piece is merely to disengage the ratchet teeth. It bears no strain, as this is on the pawl, and not on the disks in the slide openings of the yoke. This is demonstrated by taking the four working parts, without yoke and rivets, and placing them on a pipe in proper position, as in the engraving. The manufacturers state that the grip is as secure as if the yoke and rivets were in place; the parts will remain intact and turn the pipe, showing how well the lock joint principle has been worked out and how perfectly is the distribution of the strain.

The Baltimore & Ohio Railroad now runs its freight trains over its own tracks into New York City. Years ago a line was built from Cranford Junction on the Jersey Central to St. George, Staten Island, crossing the Kill Von Kull on a long bridge and trestle, and all B. & O. freight, either inbound or outbound, was handled from that point. The recent extension of the limits of New York City has made Staten Island a part of Greater New York, and the B. & O. now enjoys the distinction of being the only line from the West, except one, which has its own rails into the city of New York.

THE NATIONAL ASSOCIATION OF MANUFACTURERS.

The third annual convention of the National Association of Manufacturers is assembling in New York as we go to press, and indications promise that it will be the event of the year for the manufacturers of the United States. There are so many inquiries as to the object, scope and purpose of the organization that we feel warranted in giving space to a brief statement of the work.

The association was formed in January, 1895, and by a gradual development it has now reached a membership of 1,000 of the most influential of the manufacturing interests of the country. The movement started with purposes of a very general character, with two objects in view, the first of which relates to the home interests of manufacturers of the United States, and the other had to do with the foreign trade.

The objects in connection with the home interests are: The conservation of the home market, the creation of a Federal Department of Commerce and Industry, the improvement of the patent laws, the unification of railroad freight classification, the enactment of a uniform bankruptcy law and the improvement of internal waterways. The association stands for the protection of American industries, and the tariff is viewed as a business problem, and not as a matter of political capital.

No feature of the home work of the association has met with more favor than the part that has been taken in the movement for the creation of a Federal Department of Commerce and Industry, through the efforts of a strong committee of its mem-

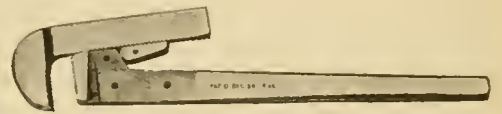

bers and by the circulation of a large amount of printed matter relating to the subject, the association has done its full share in keeping alive public interest in the matter and in making the advantages of the proposed department more widely and better understood.

The consideration of needed reform in patent laws and in the practice of the Patent Office comes naturally into the programme of the association; for no interests are touched more closely by the operation of the patent system than the manufacturers of this country.

The work which the association has been doing in the extension of the foreign trade of American manufacturers has attracted a great deal of attention, both at home and abroad. The chief features embraced by this work are:

Investigation of foreign markets, establishment of sample warehouses, improvement of the consular service, restoration of the American merchant marine, and restoration of treaties of reciprocity.

In this work, as in all else undertaken by the association, the aim is to apply practical business methods. The plans for the foreign work of the association provide for the careful investigation of possible new markets for American products, the study of trade conditions in various countries, and the ascertainment as fully as possible of the classes of American goods saleable in different markets, with the conditions of competition which must be met.

This work is preliminary and preparatory to larger undertakings in the way of establishing depots under the management of the association in such foreign trade centres as seem to offer the best opportunities for the development of larger trade. These agencies are designed to be warerooms for the display of American merchandise of every description under conditions that will secure the most favorable attention of the possible purchaser.

It is believed by the management of the association that this plan can be applied with excellent results in many foreign countries, particularly in the Latin-American trade centers. Investigations with this end in view are being conducted in several countries, and the first warehouse in the system has

been established in Caracas(Venezuela, under particularly favorable conditions, created by a special concession from the Venezuelan Government.

A series of such establishments, covering all the important trade centers abroad, will strengthen American trade interests in foreign markets to an extent that can hardly be estimated. Every such establishment will be a source of live information about foreign markets and about American goods which will be at the disposal of the foreign merchant who wishes to buy, and the American manufacturer who is seeking to sell.

This plan of promoting foreign trade has received the hearty approval and support of the foreign governments that have been established in Caracas, Venezuela, under particularly favored conditions in a practical manner.

An important feature of the work of the National Association of Manufacturers is the publication of a large amount of matter that is of general interest and value to manufacturers. The Circulars of Information issued by the Bureau of Publicity of the Association have rendered valuable aid in promoting the interests of the organization.

The association publishes a small fortnightly paper, entitled "American Trade," which conveys to its readers much information about the commerce of the world and the part which the merchants and manufacturers of the United States have therein.

The most important publication undertaken by the association is a Buyer's Directory of the members, arranged and classified in such manner as to show the business of each member, with the information that is most desired by the foreign merchant who wishes to buy American goods. This book is now in process of preparation for early publication, and a large edition will be distributed among the merchants in the English-speaking countries.

The general offices in Philadelphia, which are under the immediate direction of the President, are in close touch with a large number of correspondents in the principal centers of the world. Information and inquiries from all parts of the world come to the association as the recognized organization of those American manufacturers who are interested in foreign trade, and the distribution of this information among the members of the association results in substantial benefits.

The Bureau of Information which is conducted for the benefit of the members of the association, possesses a great amount of material regarding the trade of the world, which is placed freely at the disposal of the members. Special inquiries concerning any line of business are undertaken for members when desired. Information concerning the financial standing and general responsibility of foreign merchants is furnished without charge.

An annual fee of \$50 entitles a manufacturer to membership and to all the privileges incident thereto during the period of 12 months from the date of payment. Only manufacturers are eligible for membership.

The officers of the association include a President, Treasurer and Secretary, elected by the members in the annual convention, and a Vice-President for each State. The general policy of the association is outlined in the annual convention, and specific lines of work are indicated to the Executive Committee, which includes the general officers, the vice-presidents from the 12 largest manufacturing States and four members-at-large. The address of the Philadelphia office is 1,743 North Fourth street. The New York office is 89 Times Building. The names of Mr. Charles A. Moore, John H. Converse and Mr. C. F. Quincy are well known to our readers. The first two are members of the executive committee, and Mr. Quincy is one of the vice-presidents of the association.

THE CLEANING OF TRIPLE VALVES.

We have received a communication from Mr. G. W. Rhodes, Superintendent of Motive Power of the Chicago, Burlington & Quincy Railroad, including a circular letter issued by him to his subordinates, which is of interest as showing the difficulties of carrying out the requirement of inspecting and cleaning all triple valves once in every 12 months. The showing made upon this road may seem surprising, but it is very doubtful whether it is improved upon or even approached by other roads. It is possible that cleaning triples every 12 months is more frequent than is really necessary. This limit, however, was adopted by the Master Car Builders' Association,

with the approval of the men who are best versed in such matters. There is nothing to commend the practice of allowing safety appliances or any other mechanical apparatus used on railroads to run until they show that they are unfit for further service, and the subject is of such importance that we are glad to be able to show the steps taken on the Chicago, Burlington & Quincy in the interest of safety. The circular by Mr. Rhodes is dated, Aurora, January 14, 1898, and is reproduced in full as follows:

"Now that we are getting a great many air-brakes in service it is very important that they should be properly maintained. The M. C. B. rules allow triple valves to be cleaned once in 12 months. We now have on the C., B. & Q. system 16,413 freight cars equipped as of January 1, 1898, with air-brakes. To get over these once a year the whole system ought to clean 1,368 per month. The attached table shows the number of triples cleaned on the C., B. & Q., from June to December, 1897. You will observe that during December we cleaned as follows:

C., B. & Q. triples	282
System line	219
Foreign line	7

Total 508

SHOWING NUMBER TRIPLE VALVES CLEANED FOR C., B. & Q. R. R.

Months.	Chi. Div.	Gales. Div.	St. L. Div.	E. Ia. Div.	E. Ia. Div.	W. Ia. Div.	Total.
June	80	35	29	21	35	29	250
July	75	50	42	36	87	16	331
August	109	65	40	31	98	7	366
September	141	67	41	27	75	7	392
October	175	100	30	31	50	8	440
November	149	29	22	24	50	4	313
December	162	28	18	27	21	7	282

Total 891

Months.	Chi. Div.	Gales. Div.	St. L. Div.	E. Ia. Div.	E. Ia. Div.	W. Ia. Div.	Total.
June	35	14	25	10	17	11	119
July	59	25	12	18	46	8	179
August	91	30	17	22	24	..	202
September	182	26	10	10	34	..	279
October	155	30	12	13	30	6	255
November	149	9	14	18	17	2	225
December	154	8	9	17	18	..	219

Total 825

Months.	Chi. Div.	Gales. Div.	St. L. Div.	E. Ia. Div.	E. Ia. Div.	W. Ia. Div.	Total.
June	1	9	10
July	1	4	6
August	5	..	7
September	2	6	8
October	3	2	3	8
November	3	2	6	11
December	7	7

Total 10

"If the M. C. B. Association is all right in its opinion that triples under freight cars should be cleaned at least once a year, the practice on the C., B. & Q. is very far from perfection. I wish you would again consider this question.

"The above figures do not include the triples cleaned by the Burlington & Missouri Railroad in Nebraska and those cleaned by the Missouri lines. If we assume that together they have cleaned as many as the C., B. & Q., it will still leave us considerably short of getting over our triples once a year."

THE RAILWAY SIGNALING CLUB.

The annual meeting of this club was held January 11, at the Great Northern Hotel, Chicago, President W. J. Gillingham, Jr., presiding. A number of new members were elected and the secretary reported the result of a letter ballot on the question of colors for night signals. The vote of the club stood 26 for red and green, 9 for red and white, and 3 for other systems. The club then listened to the paper of the evening on "The Signal Engineer," by W. H. Elliott, signal engineer of the Chicago, Milwaukee & St. Paul. The discussion was deferred until the next meeting. The following officers were elected for the ensuing year: president, George P. Fowle, signal engineer, Pennsylvania Railroad lines east of Pittsburgh; vice-president, W. H. Elliott; secretary, E. M. Seitz re-elected; member of the executive committee, H. M. Sperry.

Before the meeting the club visited the large interlocking plant, known as the "State Line" interlocking, at Hammond, Ind., where one hour was spent inspecting the excellent work recently finished by the contractors, the National Switch and Signal Company, of Easton, Pa. The crossings and connecting lines of the Chicago & Western Indiana, the Chicago & State Line, the New York, Chicago & St. Louis, the Chicago & Erie, the Chicago, Indianapolis & Louisville, the Chicago & Calumet Terminal, the Michigan Central and the State Line & Indiana City Railroads, are all operated from one tower with

157 working levers, and 67 spare spaces. The locking is of the well-known National type which is vertical. The machine is an exceedingly handsome and admirable piece of work and we are informed that the whole of the contract was executed in a way that is above criticism. It is worthy of note that the vertical type of locking permitted of making the tower only 16 feet 6 inches in depth, and it is difficult to see how horizontal locking could be applied to a plant of this magnitude, without exceeding practicable limits for the floor space required by the machine. Mr. Charles Hansel, Vice-President and General Manager of the National Switch and Signal Company, and Mr. H. M. Sperry, Signal Engineer and Western Agent, gave their personal attention to the work and they are to be congratulated upon the result. Over 200 trains are handled at this plant every 24 hours and the work is done by two levermen, who are also telegraph operators. Mr. J. B. Cox, Assistant Engineer of the Chicago, Hammond & Western Railroad, superintended the design and construction. We regret our inability to print a more detailed description of the plant, the information being received too late for use in this issue.

SUBJECTS FOR 1899 M. C. B. CONVENTION.

The committee on subjects charged with the duty of presenting to the convention of 1898 a list of subjects to be referred to committees and reported upon at the convention of 1899, asks the assistance of members of the association in preparing its report.

It is requested that members will, as soon as possible, send to the chairman of the committee at Williamsport, Pa., a list of subjects which they consider of sufficient importance to be investigated by the committees of the association.

In addition to this information the committee would be glad to have subjects suggested for informal discussion during the convention of 1898.

In making suggestions for subjects which are to be reported upon by the committees, it is desired that some thought be given to the subjects which have already received attention at the hands of the association through various committees. There are undoubtedly some subjects which have been investigated and which contained all the information necessary at the time for giving a comprehensive view of the same but on account of changed conditions it might be desirable to have the same subjects investigated further. The committee especially desires your consideration of this part of the matter. There are, of course, also many objects which have not yet been reported upon, an investigation of which would be of much benefit to the association.

The committee desires that you should send your suggestions to the chairman not later than March 1.

E. D. Nelson, Chairman,
Wm. McWood,
A. L. Humphrey,
Committee on Subjects.

TRACK IMPROVEMENTS ON THE GREAT NORTHERN RAILWAY.

Extensive track improvements recently made on the Montana Central division of the Great Northern Railway have been described by Mr. J. C. Patterson, maintenance of way engineer, of that division, in a paper read January 8, before the Montana Society of Engineers, from which the following is taken:

The most important improvement of the year has been the continuation of the work of filling the wooden trestles between Clancy and Butte. To do this two steam shovels were engaged the entire season, and part of the time three were at work. They handled nearly half a million cubic yards from the pits to the embankments. In addition, between the same points, 17 steel bridges were erected over the Boulder river and other streams, replacing timber structures. For this latter work there were built 2,440 cubic yards of heavy granite rubble masonry foundations, requiring 816 barrels of Portland cement and 1,093 barrels of Louisville. The spans for these bridges consisted of deck and through girders of various lengths from 40 to 80 feet, the total weight of steel work being 494 tons. The locations of these bridges were distributed over about 17 miles of track and the entire work from the time of commencing the excavation for foundations of the first bridge was completed in three months and ten days with no interruption to traffic. Thus our entire line from Clancy to Butte is now free from wooden bridges, with a few exceptions which have been other-

wise provided for, the old structures having been replaced by solid embankments and steel.

One of the principal objects in carrying forward this improvement so rapidly has been to provide for the use of heavier engines in the freight service. Two such engines (see the "American Engineer of January, 1898, page 1, and also the present issue) have been constructed and are expected in a few days. They are considered the largest locomotives ever built, weighing 172,000 pounds on the drivers, and having a total weight, engine and tender, of 308,000 pounds. As a comparison, these engines weigh 40,000 pounds more on drivers, and a total of 66,000 pounds in excess of the heaviest engines now in use on the line, from which an idea of their enormous size can be obtained.

For the more rapid and economical handling of engines at terminals and coaling stations, new coal chutes have been built at Great Falls and Wolf Creek, the one at Clancy has been rebuilt and a new one is now building at Ton-ton. These are mentioned, as they are believed to be a new departure in the means of handling coal quickly and cheaply. In brief, the coal is elevated in the original railroad car to a height sufficient to allow it to be dumped into pockets, and from these by gravity into the engine tenders. The power is furnished by gasoline engines, which I think is the first introduction into this State on a somewhat extensive scale of this economical power, and a somewhat inconsistent one too, at first thought when the abundance of coal is considered. However, the entire operation of one of these chutes requires the labor of one man only, who takes the coal in the car from a side track and places it in a position where the fireman, by pulling a string, does the rest.

THE PENNSYLVANIA LIMITED.

The Pennsylvania has just placed in service complete new equipment for its 24 hour limited trains, between New York and Chicago. Twenty-three new cars comprise four trains, all built at the Pullman shops and the observation car "Fortuna" is the finest work ever produced by the Pullman Company. This car is the most noteworthy and contains, besides the observation room, six exclusive compartments, each finished in different colored woods and furnished to correspond. These woods are: Circassian walnut, Tobasco mahogany, English oak, rosewood, St. Jago mahogany, and one is in vermilion. The upholstery and furnishings in these rooms is wrought tapestry. The entire train is lighted by electricity from a dynamo in the baggage car, and Frost lamps are provided for emergencies. While the observation car has more novel features than the sleepers, they all are worthy of special mention, the whole equipment being the finest in use. A departure in exterior decorations consists of painting the cars in colors. They are green below the window sills and cream color above, which is a very effective, handsome combination. The lettering and ornamentation is in gold. The cars have wide vestibules.

The amount of raw materials used in the construction of an 8-driving-wheel freight locomotive of the London Northwestern Railway as figured by Mr. F. W. Webb are printed in a recent number of "Engineering," as follows:

	Pounds.
Coal	118,800
Steel scrap	63,043
Pig iron	54,215
Wrought-iron scrap	16,352
Swedish iron	14,448
Copper ingot	11,137
Coke	10,204
Spiegel	6,373
Cast-iron scrap	3,403
Limestone	2,045
Block tin	546
Lead	83
Tile zinc	76
Phosphor bronze	70
Ferro manganese	132
Red ore	120
Chrome	30
Aluminum	13
Antimony	4

The whole weight is 139 tons for the complete engine or about one-third of the total.

Mr. O. B. Shallenberger, Consulting Engineer of the Westinghouse Company, of Pittsburg, Pa., died at Colorado Springs, Jan. 25.

At the general offices of the Northern Pacific Railway over 2,000 letters are received daily containing inquiries about transportation to the great Northwest, requests for maps of the country, etc. When spring comes the road will undoubtedly be overwhelmed with business.

ANNOUNCEMENT.

A series of articles on the Construction of a Modern Locomotive, by a motive power officer of one of the leading railroads of this country, will commence in our March number, and will treat the subject in a practical manner, from the ordering of the material to the testing of the finished locomotive. This will be a valuable record, based upon a wide practical experience, and as only a limited number of extra copies will be printed, you are urged to subscribe before the publication of the March issue.

EQUIPMENT AND MANUFACTURING NOTES.

The Michigan Central is building six six-wheel switching engines at its Jackson shops.

The Brooks Locomotive Works will build five passenger locomotives for the Long Island Railroad.

The Canadian Pacific will build 25 new locomotives during the next year, probably at its own shops.

The Illinois Central has bought three locomotives which the Rogers Locomotive Works had in stock.

The Pittsburgh Locomotive & Car Works will build seven consolidation locomotives for the Seaboard Air Line.

The Schenectady Locomotive Works have received orders to build ten ten-wheel compound engines for the Boston & Maine Railroad, and five Class A engines for the Northern Pacific.

The Richmond Locomotive and Machine Works have received orders for 15 compound consolidation locomotives for the Canadian Pacific, ten 10-wheel compound and five simple engines for the Wabash.

Locomotives have been ordered from the Pittsburgh Locomotive Works by the following roads: 20 locomotives for the Chicago, Burlington & Quincy, 4 locomotives for the Hoshin Railway of Japan, 2 locomotives for the Union Railway.

The following orders have been taken for locomotives by the Rogers Locomotive Works: The St. Joseph & Grand Island, three passenger locomotives, 20 locomotives for the International & Great Northern, and ten, ten-wheel engines for the Mobile & Ohio, five for freight and five for passenger service.

The Dickson Locomotive Works have orders for two six-wheel connected saddle tank locomotives, with 10 by 16-inch cylinders, from the Delaware & Hudson Canal Company. This firm has sold one Mogul locomotive from stock to the Richmond, Petersburg & Carolina Railroad, and two of the same type to the Buffalo, Rochester & Pittsburgh.

The Baldwin Locomotive Works have received the following orders to build locomotives: One for the Cincinnati, New Orleans & Texas Pacific, five heavy compound freight locomotives for the Norfolk & Western, two consolidation locomotives for the Hokkaido Coal Mining & Railway Company, of Japan. The Terminal Railroad Association, of St. Louis, has placed an order with this firm for two six-wheel switching engines. They are also building four compound consolidation engines for the Mexican National, 5 ten-wheel freight and one American passenger engine for the Charleston & Western Carolina, and three ten-wheel engines for the El Paso & Northeastern, one locomotive for the Winifrede Railroad, five Atlantic type passenger locomotives for the Wabash; they are also building five freight locomotives for the same road, two Vaucalain compound locomotives, one for freight and one for passenger service for the Barranquilla Railway & Pier Company, of Colombia, S. A.

Attractive calendars for 1898 have been received from the following firms: The Ajax Metal Co., of Philadelphia; A. M. Castle & Co., of Chicago; the Magnolia Metal Co., of New York; the Ashton Valve Co., of Boston; Messrs. Bruce & Cook, of New York and William Jessop & Sons, of New York.

Jackson & Woodin have an order for 250 coal cars for the Beech Creek Railroad.

The Union Car Company has an order for 250 coal cars for the Beech Creek Railroad.

The Allison Manufacturing Company is building three cars for the Pennsylvania Salt Manufacturing Company.

Two hundred freight cars are being built at the Fort Wayne shops of the Pennsylvania lines west of Pittsburgh.

The Canadian Pacific will add 1,000 new freight cars to its equipment during 1898. These will probably all be built at the shops of the road.

The Illinois Central has ordered 100 standard Rodger ballast cars from the Rodger Ballast Car Company. They will carry 30 cubic yards of ballast and will be of 80,000 pounds capacity.

The St. Charles Car Company have received orders for the following cars: 9 for the Kalso & Slocan, 100 freight cars for the Mississippi River & Bonne Terre, and one passenger for the Centralia & Chester.

The Indiana Car & Foundry Company is building 50 flat cars for the Commerce Despatch Line, 100 stock cars for the Mather Stock Car Company. They will equip 100 cars with air-brakes and automatic couplers for the Alton Terminal Railroad.

The Missouri Car & Foundry Company have received the following orders for cars: 119 box cars for the Vandalia Line, 40 coal and 20 box cars of 60,000 pounds capacity for the El Paso & Northeastern, and 500 box cars for the Baltimore & Ohio.

The following orders have been received for cars by the Wells & French Company, of Chicago: One thousand fruit cars, with Simplex bolsters, for the Armour Company; 100 Standard ballast cars for the Southern Pacific; 13 refrigerator cars for the St. Charles Refrigerator Despatch.

The Terre Haute Car and Manufacturing Company have received orders for 500 box cars for the Chicago, Milwaukee & St. Paul. They will be 34 feet long, of 60,000 pounds capacity, equipped with Westinghouse air-brakes, Janney couplers and Chicago grain doors. They will also build 300 coal cars for the Mobile & Ohio.

The following orders have been taken for cars by the Ohio Falls Car Manufacturing Company: 100 freight cars for the Pittsburgh, Bessemer & Lake Erie, 250 coal cars for the Baltimore & Ohio Southwestern, 50 flat and 10 box cars for the Atlantic, Valdosta & Western, and 200 coal, 200 box and 100 furniture cars for the Cincinnati, New Orleans & Texas Pacific.

The Illinois Car & Equipment Company have received the following orders for cars: 200 refrigerator and 10 tank cars for the Cudahy Packing Company. They will be 36 feet 8 inches over end sills, 8 feet 10 inches over side sills and equipped with Miners' draft rigging, Westinghouse air-brakes, automatic couplers and either Simplex or American steel bolsters. They also have an order for 50 flat cars for the Hanover Construction Company, and one for the Duluth & Iron Range for 300 ore cars with National hollow brake beams; McCord journal boxes and Tower couplers; and one from the Minneapolis & St. Louis for 200 box cars.

The Barney & Smith Car Company have received orders for 500 new box cars for the Indiana, Decatur & Western.

The Michigan-Peninsular Car Company is building the following cars, 750 for the Michigan Central, 2,000 cars for the Baltimore & Ohio, 500 for the Indiana, Decatur & Western Railroad, these will be 36 feet long inside in the clear, of 60,000 pounds capacity and equipped with Westinghouse brakes, Chicago roofs, Sterlingworth-Marden brake-beams, American couplers and Detroit springs. This firm has an order for 500 coal cars from the Beech Creek Railroad, one for 50 refrigerator cars for the Hammond Refrigerator Line, and one for 500 coal cars for the Pittsburgh & Lake Erie. Four hundred cars in the last mentioned order will have Simplex bolsters and 100 will have American steel bolsters.

The Buffalo Car & Manufacturing Company has an order for 500 coal cars from the Lake Shore & Michigan Southern.

The Mt. Vernon Car Company has an order for 250 fruit cars for the Florida Central & Peninsula, and for 200 box cars for the Mobile & Ohio.

The Pullman Palace Car Company has orders for the following cars: 3,000 box cars for the Baltimore & Ohio, 750 box cars for Baltimore & Ohio and for 200 box cars for the Mobile & Ohio.

The Jackson & Sharp Company, of Wilmington, Del., has recently finished building two electric cars for the Bennington & Hoosac Falls Electric Railroad, one for the Gloucester, Essex & Beverly electric line, of Gloucester, Mass., and seven for the Syracuse & Suburban Railroad, of Syracuse, N. Y. The company has also ready for shipment one freight car for the last named road. They have completed a new car for President Henry M. Flagler, of the Florida East Coast Railroad. It is 71 feet 6 inches long, handsomely finished and is lighted with Pintsch gas.

Messrs. Neilson & Co., The Hyde Park Locomotive Works, Glasgow, Scotland, state in a recent communication to us that the designation of the firm has been changed to Neilson, Reid & Company. The constitution of the firm, however, is unchanged.

A handsome calendar for 1898 has been received from the Ashton Valve Company, of Boston. It bears an engraving in two parts with children's figures, representing "Sunshine and Shadow," which merits preservation after the calendar itself has served its intended purpose.

Judge Wheeler, of the United States Circuit Court, at New York has handed down a decision sustaining the validity of the electric railway motor suspension patent controlled by the General Electric and Westinghouse Companies and ordering an injunction against the Union Railway Company, of New York, and the Walker Company of Cleveland.

The Monarch Brake Beam Co., Lim., of Detroit, announce the appointment of Mr. Harry W. Frost, formerly Secretary and Western Business Representative of the "Railway Age" as their General Sales Agent, with headquarters at 745 Old Colony Building, Chicago. They also announce the appointment of Mr. Charles F. Pierce as their Eastern Sales Agent, with headquarters at 1203 Havemeyer Building, New York City.

The new coal plant that the Baltimore & Ohio Railroad is erecting at Sandusky, Ohio, will consist of an elevated track, to be used either with slide-dump or drop bottom cars, the coal dropping into bins from which it will flow into buckets of four tons capacity, each placed upon movable platforms. Derricks of a capacity of ten tons each will lift the buckets to the vessel. There will be sixteen of these patent drop bottom buckets, they will be handled by two of the latest steam revolving derricks, and these machines will give the plant a capacity of about 300 tons of coal per hour, at a minimum cost for the work and with a slight breakage. The plant will be in operation by April 1st.

The Sessions Foundry Co., of Bristol, Conn., have recently secured a number of important contracts for iron castings for the coming year, among them being a renewal of their previous contract with the Providence Steam Engine Co., well known makers of the Greene engine. This is very heavy work, and when business is good amounts to many tons per day. The Sessions Foundry Company's business for the past year has been the largest in its history, and from present indications will be considerably larger the coming year.

The Chicago Pneumatic Tool Company is meeting with the best of encouragement in the introduction of pneumatic riveters, particularly in connection with shipbuilding, which happens to be the field into which they are being first extensively introduced. They are reported to have made a marked success already in now driving rivets as large as 1½ inches in diameter, the work being superior to squeezed and even

hand riveting. This of itself is a wide field, and if the present indications are fulfilled ship plate riveting will be revolutionized.

The Bethlehem Iron Company has received an order from the United States Government for fifteen 4-inch rapid-fire guns complete with mounts. This is the first order for such equipment complete by the same concern, it having been customary to have guns forged, finished and mounted by separate concerns.

The experience with copper sheathing on one of the coaches of the New York, New Haven & Hartford during the past year has been so satisfactory as to lead to the decision to experiment further in this direction, and experiments are to be tried with cars sheathed with aluminum sheets and aluminum bronze.

The Detroit Lubricator Company has introduced an improvement in cylinder lubricators for locomotives, which consists of taking steam from a point in the dry pipe just ahead of the throttle valve, and applying it to the oil passing through the lubricator, in order to overcome the stoppage in the cylinder pipes due to the back pressure from the steam chests while the throttle is open. By connecting the lubricator to the dry pipe, the opening of the throttle insures a pressure on the oil which is said to cause regular feeding of the lubricators. This is an improvement upon the Tippet attachment illustrated in our issue of October 1897, page 355.

Mr. Robt. Andrews, vice-president of The Safety Car Heating and Lighting Co., said a few days ago that his company could find no fault with business done in '97, despite the hard times. The company equipped 1,584 cars with the Pintsch system of lighting during the year. The work done for the United States Light House Department includes the equipping of ninety-four buoys, two beacons and two lighthouse tenders with the Pintsch light. A total of 11,112 cars are so equipped in this country and 83,500 throughout the world.

Dispatches from Philadelphia state that the Pennsylvania Railroad has placed orders for 100,000 tons of 100-pound steel rails, as follows: Pennsylvania Steel Company, 25,000; Cambria Iron Company, 25,000; Carnegie Steel Company, 30,000; Lackawanna Iron Company, 5,000, and the Illinois Steel Company, 15,000 tons.

Mr. John A. Walker, vice-president of the Joseph Dixon Crucible Company, says, in a recent communication: "The industrial triumphs of 1897 are important. In this year the business cloud passed away and another era of prosperity, hopefully of long duration, opened. Export trade was larger in the fruits of the harvest, and particularly in manufactured goods, than in the history of the country. Americans are competing in every market. American motors won the order in London. On a bridge in Holland an American firm was the lowest bidder. American steel rails go regularly to China, Japan and India. For the Dixon Company, we have shared in the general prosperity. The year has been an agreeable one, the future looks rosy to those who have eyes to see. Perhaps the outlook was never more inviting. Never were there so many roads open to wealth to those who know how to find them."

There is no novelty about oil distributing systems, which make use of piping and the force of gravity to carry lubricants from a central source of supply to the various bearings in a room full of machinery or to the bearings of a large engine, but the application of compressed air to such distribution is novel. The Q and C Company, of Chicago, has recently introduced a pneumatic lubrication system, whereby oil is forced through piping to various bearings, and by return piping, it is carried through a filter and back to the supply reservoir again. The pressure feature of the system renders it applicable in a marine engine room, where a gravity system would not work on account of the rolling of the vessel. It may also be used in places where the supply must be below the level of the bearings to be lubricated. The system is described in a circular which will be sent upon application.

The American Balance Valves manufactured by the American Balance Valve Co., of Jersey Shore, Pa., were specified for the locomotives building at the Schenectady Locomotive Works for the Northern Pacific Railway referred to elsewhere in this issue. They will also be furnished for the 8-wheel locomotives by the same builders for the Imperial Government Railway of Japan, illustrated elsewhere in this issue.

William H. Wood, engineer and builder of special machinery, Media, Pa., reports that he has recently furnished one of his hydraulic riveting and flanging plants to the Gaar Scott Co., of Richmond, Ind., and one of his patent 1,100-pound single standard steam hammers, and a hydraulic multiple punch, to the Fox Solid Pressed Steel Co., of Joliet, Ill.; also a hydraulic riveting plant to Messrs. H. B. Beach & Sons, of Hartford, Conn., and a 12-foot hydraulic riveting plant to the Dickson Locomotive and Machine Works, of Scranton, Pa. One hydraulic upsetting machine and an 18-inch horizontal hydraulic draw bench, 10-foot stroke, both for the National Tube Works of McKeesport, Pa. One 800-pound steam hammer to John Muirhead & Son, of Pittston, Pa. One 10-foot hydraulic riveting and flanging plant to the Enterprise Boiler Co., of Youngstown, Ohio. One hydraulic riveting plant for Berger Bros. & Co., of Columbus, Ohio. One hydraulic pressure pump for the Cooke Locomotive Works, of Paterson, N. J., and one of the largest hydraulic riveting plants made for the Chas. Hillman Ship and Engine Building Co., of Philadelphia, Pa.; also one 1,100-pound patent single standard steam hammers for the Du Bois Iron Works of Du Bois, Pa., and a large number of patent hydraulic automatic safety valves for the foot of accumulators and pressure reducing valves for riveting machines for a large number of firms. This list speaks well for the business that Mr. Wood is doing.

The Magnolia Metal Company has an extensive trade in the United States and Canada as well as abroad and during the past few years numerous infringement cases have arisen with those who have made fraudulent use of their trade marks and infringed their patents. An injunction was granted on December 15, 1897, by Lord Chief Justice Russell in the Queen's Bench Division of the High Court of Justice, London, England, enjoining the Tandem Smelting Syndicate, Ltd., and restraining them from passing off their metal for Magnolia metal, it being made up in such a way as to counterfeit Magnolia metal. A few months ago the Globe Engineering Co., Ltd., of Manchester (now in liquidation), shipped a quantity of metal to a firm in South Africa on an order for Magnolia metal. The metal sent to fill this order was made up into ingots to represent the well-known ingots of Magnolia Anti-Friction metal. They bore the words "Magnolia Anti-Friction Metal," but the trade mark, the magnolia flower and the words "patented June 3, 1890," were not imprinted upon them. The purchaser brought an action in the High Court of Justice, at the Manchester Assizes, against the sellers and judgment was given in his favor by the arbitrator to whom the matter was referred. The Magnolia Metal Co. has called our attention to



the matter and desires to warn the public, through our columns, against fraudulent imitations. Genuine Magnolia Anti-Friction metal is made up into bars of which the accompanying engraving shows the appearance, and the trade mark, which is also shown herewith, together with the name of the concern is always stamped on the bars and on the boxes in which they are shipped. In addition to this the following words are stamped upon the under side of each bar: "Patented June 3, 1890," and "Manufactured in the United States." The trade mark is registered in every civilized country. The company informs us that similar frauds are being perpetrated in this country, and they offer a reward of one thousand dollars for the arrest and conviction of any individual or firm infringing their trade mark or patents.

Our Directory

OF OFFICIAL CHANGES IN JANUARY.

Chicago, Peoria & St. Louis.—The office of General Manager H. W. Gays, of the Chicago, Peoria & St. Louis and the St. Louis, Chicago & St. Paul, will be transferred from Springfield, Ill., to St. Louis.

Central of Georgia.—The announcement in our last issue that J. H. McCann succeeded W. H. Stulb as Master Mechanic at Augusta, Ga., is incorrect. Mr. Stulb is succeeded by Mr. P. J. Milan.

Chicago & Northwestern.—Mr. Hiram R. McCullough has been made Third Vice-President, to succeed Mr. H. G. Burt, recently elected President of the Union Pacific.

Chicago, St. Paul, Minneapolis & Omaha.—Mr. J. C. Stuart has been appointed General Superintendent, he was formerly Superintendent of Galena division of the Chicago & Northwestern.

Gulf, Colorado & Santa Fe.—Mr. T. O. Wood has been appointed Purchasing Agent, with headquarters at Galveston, Tex., vice Mr. W. E. Hodges, General Purchasing Agent, resigned.

Holly River.—Mr. Charles M. Warner has been elected Vice-President, vice Mr. C. R. Elliott.

Illinois Central and Yazoo & Mississippi Valley.—Mr. David Sloan has been appointed Chief Engineer of these roads.

Illinois Central.—Mr. C. A. Beck, heretofore Assistant Second Vice-President, has been appointed General Purchasing Agent, with office at Chicago, Ill. He has been succeeded by Mr. John F. Wallace, who was formerly Chief Engineer of this road.

Iowa Central.—Mr. C. W. McMeekin has resigned as Chief Engineer of this road, to accept a position with the Anaconda Copper Mining Co., at Anaconda, Mont., and the office of Chief Engineer has been abolished.

Kansas City, Pittsburg & Gulf.—Mr. F. Mertsheimer has been appointed General Superintendent. He was formerly Superintendent of Motive Power of this road.

Kansas City & Northern Connecting.—Mr. F. Mertsheimer, who was recently appointed General Superintendent of the Kansas City, Pittsburg & Gulf, has also been made General Superintendent of this road. Mr. T. C. Sherwood has resigned as General Manager to engage in other business, and the title has been assumed by Mr. Robert Gillihan, General Manager of the Kansas City, Pittsburg & Gulf.

Lawrence & Emporia.—Mr. Hiram P. Dillon has been appointed Receiver.

Leigh Valley.—Mr. Robert H. Sayre has been appointed Assistant to the President. He was formerly Second Vice-President, and is succeeded as Second Vice-President by Mr. J. B. Garrett, formerly Third Vice-President.

Louisville, Evansville & St. Louis.—Mr. Elliott Holbrook, Superintendent, with headquarters at Princeton, Ind., will in addition to his present duties assume charge of the engineering, bridge and building departments, with title of Superintendent and Chief Engineer, with office at the same place.

Maricopa & Phoenix & Salt River Valley.—Mr. C. C. McNeal has resigned as General Superintendent.

New York & Ottawa.—Mr. C. B. Hibbard has been appointed Superintendent and Master Mechanic, with headquarters at Moira, N. Y., succeeding Mr. E. La Lime, resigned.

Omaha, Kansas City & Eastern.—The following appointments and changes have been made: Mr. Robert Gillihan has been appointed General Manager and Chief Engineer, with headquarters at Kansas City, Mo.; John M. Sevin, heretofore General Manager, has been made Assistant General Manager and General Superintendent, with headquarters at Quincy, Ill.; John Voorhls has been appointed Division Master Mechanic, with office at Quincy, Ill.; E. M. Collins has been made Assistant Chief Engineer at Trenton, Mo.; C. E. Soule has been made Superintendent, with headquarters at Quincy, Ill.; W. N. Allen has been appointed Stationer, with office at Kansas City, Mo.

Randsburg Railway of California.—Mr. Edgar Van Etten has been chosen President. He was formerly General Superintendent of the New York Central & Hudson River.

South Carolina & Georgia.—Mr. James Meehan has been appointed Superintendent of Motive Power and Machinery, with headquarters at Charleston, S. C., in place of Mr. J. H. Green, resigned.

Southern.—Mr. A. H. Plant has been appointed Auditor, with office at No. 1300 Pennsylvania Avenue, Washington, D. C. Mr. Frank S. Gannon has issued the following general order, the offices of Mechanical Engineer, General Superintendent, Superintendent of Transportation, General Storekeeper, and Fuel Agent will be abolished, and the Chief Engineer will be relieved of the charge of maintenance of way.

St. Louis Southwestern.—The headquarters of Mr. H. G. Kelly, Chief Engineer, have been removed from Texarkana, Tex., to Tyler, Tex.

Wisconsin & Michigan.—Mr. John Bagley, Vice-President, and Mr. J. N. Faithorn, General Manager of this company have resigned their respective positions, and will be succeeded for the present by Mr. S. M. Fischer, who is President and Treasurer of the company, with headquarters at Chicago.

AMERICAN ENGINEER

CAR BUILDER AND RAILROAD JOURNAL.

MARCH, 1898.

CONTENTS.

ILLUSTRATED ARTICLES:	Page	MISCELLANEOUS ARTICLES:	Page
Concord Shops—Boston & Maine Railroad.....	73	Steel Cars of Large Capacity.....	86
Removable Covering for Locomotive Boilers.....	78	Railway Clubs at Niles Tool Works.....	88
Construction of a Modern Locomotive.....	79	Gold Electric Heaters Alley "L" Chicago.....	88
Passenger Locomotive—Southern Railway.....	82	Lectures as Purdue University.....	88
Great Northern Mastodon Locomotives.....	84	Engineering Notes.....	92
Condensers for Shop Engines—C., M. & St. P. Ry.....	87	Experimental Locomotive Columbia University.....	97
The "Perfect" Passenger Truck Lubrication of Driving Journals.....	89	Economical Locomotives.....	99
Sheffield Standpipe.....	91	Locomotive Boiler Lagging.....	103
Double Stack Locomotive.....	98	Chicago & Denver Train Service.....	105
The Empire Air Hoist.....	99	G. W. Rhodes at Purdue University.....	105
Test on Chicago Storage Battery Railroad.....	100		
A Steel Frame Box Car.....	101	EDITORIALS:	
The Solid Brakebeam.....	102	Lubrication of Driving Journals.....	90
Compound Locomotive—O. & L. C. Railroad.....	102	Engineers' Strike in England.....	90
		Raising Wages of Shop Men.....	90
		Informing Enginemen as to Prices.....	90
		Westinghouse High-Speed Brake Condensers for Shop Engines.....	91
		Uniformity in Naval Construction.....	91
MISCELLANEOUS ARTICLES:			
Tonnage Rating of Locomotives.....	85		

CONCORD SHOPS—BOSTON & MAINE RAILROAD.

Last month a general description of these shops, illustrated with an inset, was presented simultaneously in the "American Engineer," and the "Railroad Gazette," by special arrangement. The description is continued in both papers by a presentation of some of the features of the locomotive shop and planing mill. The electrical work, including the generators and motors, the power-house and the steam distribution systems, will be described in a subsequent issue.

LOCOMOTIVE SHOP.

The machine, erecting, boiler and tank shops for locomotive work are all in one building. The erecting shop occupies the central portion of the main building, which is 305 feet long by 130 feet wide. The wings, 30 feet wide, on each side, are used for the machine shop, while the boiler and tank shop occupies an extension of the central portion of the building, 105 by 70 feet at the south end. This arrangement is admirable, and is worthy of attention by all who are contemplating the building of new shops. Its chief merits are concentration of all of the locomotive work in a one-story building, without separating the parts of the shop unduly and an excellent track arrangement combined with a convenient and efficient crane system, which is made to serve alike the main locomotive shop and the boiler shop. The whole plan is specially well adapted to electrical distribution, and the arrangement of the machinery in two wings renders it easy to subdivide the power into favorable units.

The advantages of three longitudinal pit tracks in the erecting shop as well as that of extending one of them through the entire building from end to end have been already noticed. The plan adopted for these shops has the additional recommendation of placing the locomotives very near where the work is done. It will be understood that locomotives are taken into the shop on the center track, where they are dismantled, after which they are taken across to one of the work tracks by the electric cranes as illustrated in the accompanying photograph, showing a locomotive in the air. There is room for seven locomotives on each of the work tracks, mak-

ing fourteen that may be given general repairs at once, and in case of emergency the center track may also be used for repair work.

The rails for the work tracks are laid on heavy stringers, which are supported by 16-inch brick walls, forming the sides of the pits. The floors of the pits are of brick and are divided into water sheds, with drains every seventy feet, to insure dry floors for the workmen. At 35-foot intervals pockets made of 16 by 40-inch cast iron boxes are located in the pit walls toward the center of the building and to these are brought water, air and steam pipes from the supply pipes in the center pit, the locations being conveniently near the fire boxes of the locomotives. The pipes supplying these pocket connections pass from end to end of the shop through the center pit. The filling, washing out and testing of boilers may be done without moving them from the work tracks. These pits and pockets are shown in the drawing. At the center of the building a cross pit connects the two steam heating coils under the shop tracks. This pit is used for the heater pipes that come into the building through the pit under the center track, and they are also used to convey air and water pipes to the sides of the building, along which these pipes extend on the roof trusses, tees being provided to bring them to the floor at each section, so that air and water may be had at many points about the building.

The numerous and easily accessible benches are worthy of notice. There are eight on each side of the shop, and their close proximity to the engines undergoing repairs is a matter of considerable importance. They are placed between the crane supports, every other space being left vacant for gangways. The toolroom is about 20 by 45 feet in size and is located on the west side near the center of the building. South of this are two large vise benches, beyond which is the air-brake room, 20 by 20 feet in size, with provisions for holding 30 pumps at once.

The floor of the shop is of concrete, over which rough planks are laid in hot pitch, the top course of the floor being of one and one-eighth inch floor boards.

The motors for driving the machinery in the wings are located beside the center door of the building. The one on the east side, which drives the heavier machinery, has a capacity of 30 horse-power, while that on the west side, driving the lighter machinery, is a 20 horse-power motor. This gives two power units as far as the motors are concerned. They will be fully described later. The shop is again divided into north and south sections on each side by means of Worrall clutches on each side of the driving pulleys, which gives four shaft units, any of which may be disconnected when not in use, and the friction of the shafting as a load on the generators saved. In passing, it is well to mention that while a more minute subdivision may appear to many as a desirability in such a shop, it was not considered advisable for two reasons; the machinery could be so grouped as to make it usually necessary to run a whole or nearly a whole group at the same time, and the high cost of supplying small individual motors to each machine or to a small group of machines, prevented further subdivisions. The cost of a small motor is much greater proportionately to its size than that of a larger one, and even if the larger motors must run lightly loaded at times, this plan was thought to be the most convenient for this case. One of the best features of electric distribution is that with the plant once installed any number of plans may be tried, and if further subdivision appears advisable, there is nothing to prevent carrying it out. With a motor to each machine the power considered individually is so small that the cost for motors would be enormous and not warranted by advantages gained.

The line shafts run at a speed of 200 revolutions per minute, and all four of the sections are practically alike. The first length on each side of the clutches is 12 feet, followed by eight lengths of 16 feet. The supports are double brace-drop hangers, each placed four feet on either side of the trusses, or eight feet apart. All main-line shafting in this building is

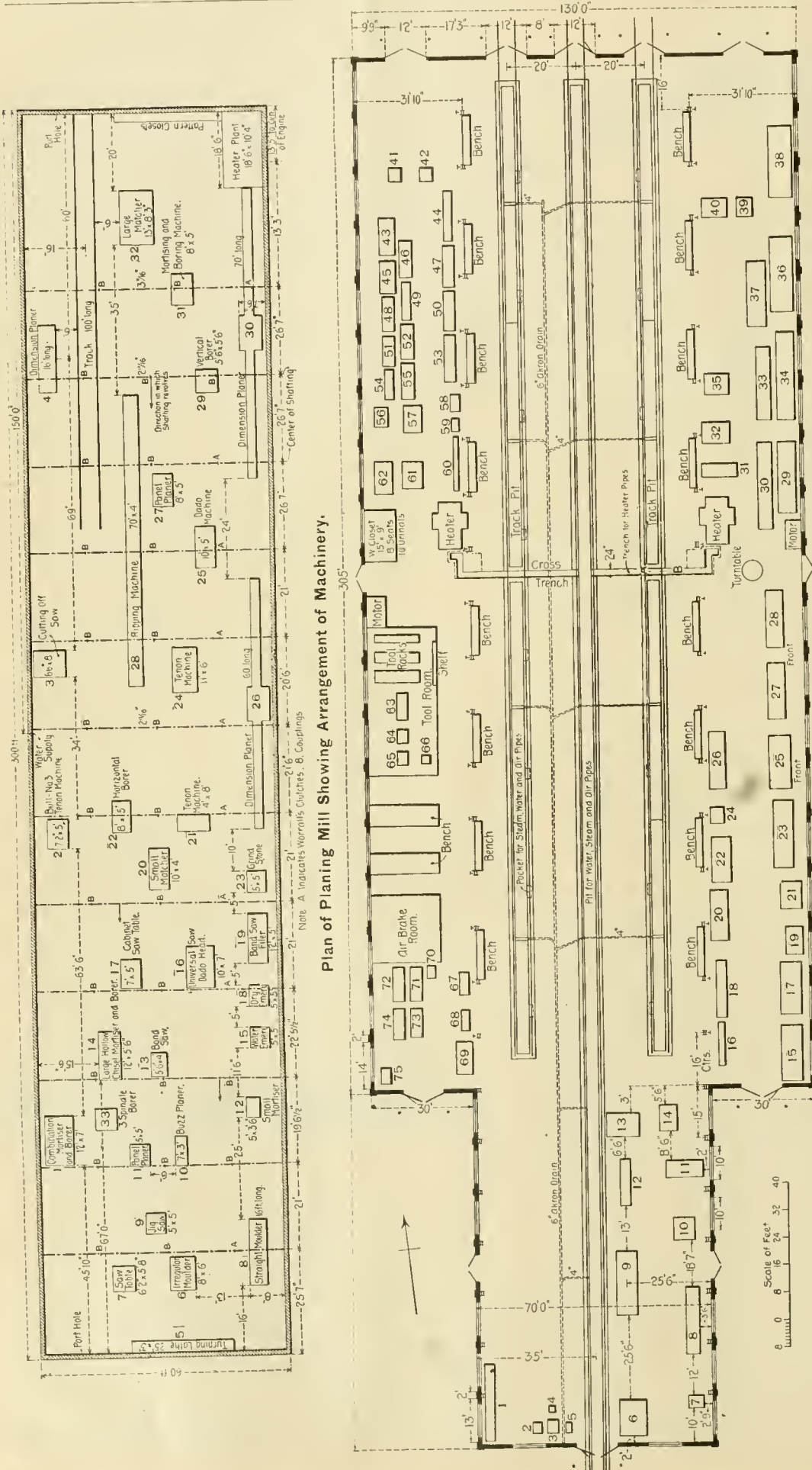

Plan of Locomotive and Boiler Shops Showing Arrangement of Machinery.

KEY TO TOOL LOCATIONS—MACHINE SHOP.

- | | | | | |
|--|---|---|---|--|
| <p>1. Blue tester.
2. Drill-press.
3. Tube welder, furnace.
4. " cutter.
5. Shear.
6. Punch.
7. Plate planer.
8. Pipe rolls.
9. Radial drill.
10. Flanged punch.</p> | <p>12. Clamps.
13. Flanging forge.
14. Grinder block.
15. Car-wheel lathe.
16. Wheel press.
17. Car-wheel lathe.
18. Lathe.
19. Car-wheel borer.
20. Lathe.
21. Car-wheel borer.
22. Lathe.</p> | <p>23. Car-wheel lathe.
24. Grinding.
25. Driving-wheel lathe.
26. Driving-wheel press.
27, 28. Driving-wheel lathes.
29, 30. Planers.
31. Radial drill.
32. Slotter.
33, 34. Planers.
35. Slotter.</p> | <p>36, 37, 38. Planers.
39, 40. Shapers.
41, 42. Drills.
43 to 55. Inclusive. Lathes.
56, 57. Boring mills.
58. Grinder.
59. Centering ring.
60. Speed lathe.
61. Drill.
62. Slotter.</p> | <p>63, 64, 65, 66. Lathe, milling machine, tool grinder, and twist drill grinder.
67, 68. Bolt cutters.
69. Screw machine.
70. Drill.
71, 72. Brass lathes.
73. Speed lathe.
74. Fox turret lathe.
75. Nut tapper.</p> |
|--|---|---|---|--|

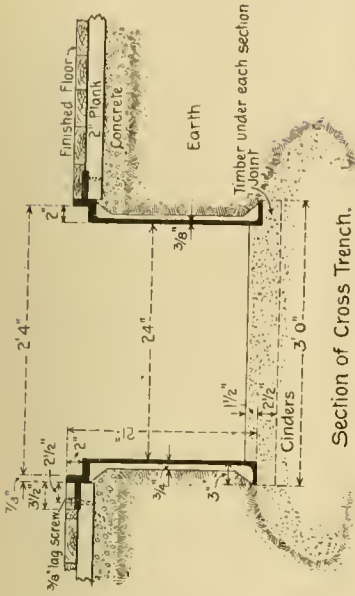

Section of Cross Trench.

Section of Cross Trench for Steam Pipes.

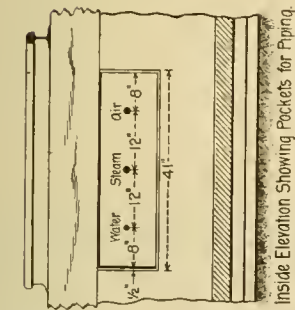

Inside Elevation Showing Pockets for Piping.

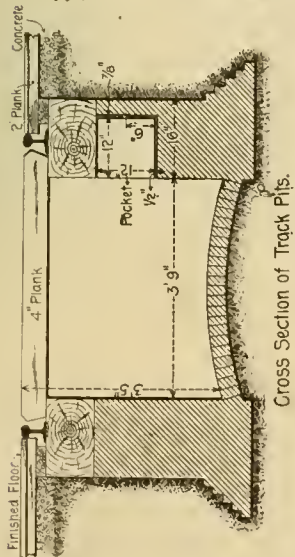

Cross Section of Track Pits.

Sections of Track Pits.

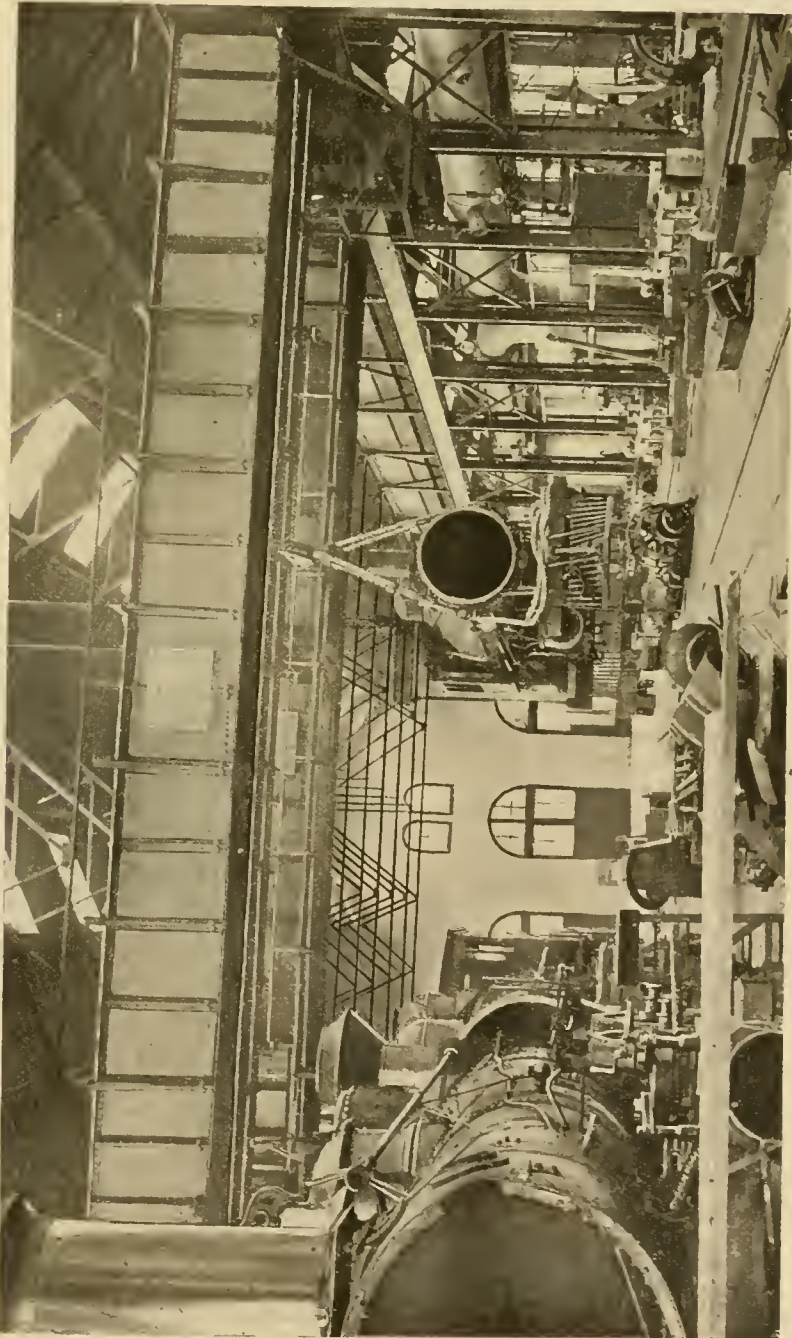

View of Locomotive Shop, Showing Cranes in Use.

CONCORD SHOPS.—BOSTON & MAINE RAILROAD.

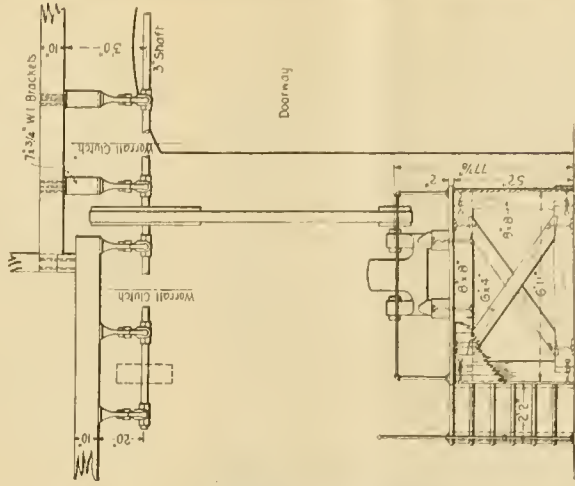

Mounting for 30-Horse-Power Motor.

2 11-16 inches in diameter, except the head shaft, at the clutches, which is 2 15-16 inches in diameter. The motors are mounted on wooden frames, to raise them from the floor and the switches and fuses are conveniently arranged.

The grouping of the machine tools was done with a view to economy in use of power when an emergency necessitates running "overtime" at night or on Sundays. It will be seen that an ideal arrangement must exist somewhere between the single motor and the individual motor plan, and that the arrangement of the tools has much to do with this question. The northeast section is occupied by planers, shapers and milling machines, and from the drawing it will be noticed that as much space as possible was left between the machines. One of the heaters is located in this section. The southeast section is wholly given up to the wheel and axle work. The driving wheel lathes are near the east wall, and directly opposite is a 300-ton hydraulic wheel press. Just beyond these are the axle and crank-pin lathes, and the hydraulic car wheel press, while opposite these are the car wheel boring mills and wheel lathes. This work is kept in one section, because wheel work forms the most important class of repairs; many engines come in for this work that are in fair condition otherwise. The northwest section has the engine lathes in two double rows, with universal drills, milling machines and boring mills at the south end. The water closets are located at the south end of this section, as shown on the plan. The southwest section, besides providing for the tool room and air-brake room, contains the brass working tools and bolt cutters. The bolt cutters are so arranged as to admit car and tender truss rods 40 feet long. At the vise benches, between the tool and air-brake rooms, 18 men are accommodated.

The arrangement of the boiler and tank shop appears on the plan. The shafting and machinery is driven from the southeast section of the machine shop by tight and loose pulleys, except the large rolls, which are driven by a direct connected 20 horse-power Westinghouse motor. The tools in this shop are all modern, and their locations provide for handling large boiler plates, some of which are nearly 8 by 23 feet in size. There are flange and straight punches, a plate planer, rolls, drills and bending clamps. The heavy lifting in this shop is done by the large electric cranes, while pneumatic hoists, post cranes and runways are employed throughout the shop for light work. The west side of the boiler shop is left vacant except at the extreme south end, where the flue scarfing, welding and testing machines are placed. The fine rattler is outside the building near this corner.

Of the machinery in this shop the Putnam Machine Company, of Worcester, Mass., furnished a No. 2 universal milling machine and the 300-ton hydraulic press. The Pond Machine Company, through Messrs. Manning, Maxwell & Moore, of New York, furnished a 36-inch planer with two heads; the Niles Tool Works, of Hamilton, Ohio, furnished one set of No. 4½ bending rolls to take plates 12 feet long between the housings, the rolls being 12 and 9 inches in diameter, driven, as stated, by a 20-horse power electric motor, a universal radial drill with five-foot arm and swiveling head, a pair of bending clamps for 12-foot plates and a plate planer to plane plates 12 feet long at one setting, and plates of any length by resetting, the carriage cuts in both directions. Messrs. Long & Alstatter, of Hamilton, Ohio, furnished a No. 2 flange punch with a seven-inch throat, capable of punching a one-inch hole in a one-inch plate and having a pull-off attachment. They also furnished a single punch and shear with 48-inch throat. Messrs. Bement, Miles & Co., of Philadelphia, furnished a 46-inch double car wheel lathe, used for wheels 42 inches in diameter. This has a caliper attachment and it is reported to average one hour five minutes in turning a pair of steel tired wheels. The other machinery is shown on the plan of this shop and the locations and list of tools are numbered to give an idea of their arrangement. This shop is lighted by 28 arc lamps and there are also 75 incandescent lights in use about the machines and locomotives.

Electric Cranes.—The importance of crane machinery in such a shop warrants a description in considerable detail. The inset accompanying the previous article presented a half cross section of the locomotive shop, showing the crane supports, which are independent of the posts of the building and bring the tops of the traversing rails 24 feet above the shop floor. This equipment was furnished by William Sellers & Co., of Philadelphia. The crane bridges are of steel, the spans of the bridges being 66 feet 4 inches from center to center of carrying wheels, while the lift is 25 feet. Each crane has one trolley with a lifting capacity of 60,000 pounds, a lifting and lowering speed of 12 feet per minute under full load, a bridge traveling speed of 200 feet per minute, while the trolley travel is 100 feet per minute. The trolley is also geared to handle loads of 6,000 pounds at a lifting speed of 48 feet per minute.

The bridge consists of two plate girders reinforced with vertical stiffening angles at short intervals, and carrying upon shelf angles near the lower flanges the rails upon which the trolley runs; these rails are of ample section and are riveted to the shelf angle and bolted through packing blocks to the stiffeners on the outside of the web. The two girders are connected over the top through their entire length by heavy cross and diagonal bracings, forming a horizontal girder, and at their ends by diagonally braced end frames; diagonal struts from the cross braces of the horizontal girder to the lower chords of the main girder maintain the vertical alignment. Each girder is riveted up complete, but the connections between them are secured by turned bolts fitting in reamed holes, avoiding the necessity of field riveting when the crane is erected. The steel used in the bridge has an ultimate tensile strength of about 60,000 pounds per square inch, an elastic limit of 50 per cent. of the ultimate, and an elongation of 20 per cent. in eight inches. The bridge parts are so proportioned that the maximum strains will not exceed 10,000 pounds per square inch in compression and 12,000 pounds in tension with the full load, and due allowance is made for strains produced by the inertia of the trolley. A foot-board or gallery is provided on one side, running the whole length of the bridge, affording an easy means of access to the bridge motor and squaring shaft.

In this construction the two girders are combined to form a single compound beam of great lateral stiffness. The bridge girders are made to project over the runway rail so as to rest thereon in case of accident or derailment, and as the drop would only be about an inch no harm would result even if the crane were carrying the full load.

The bridge is carried upon four wheels, which are fast upon short axles, the bearings for which are placed on both sides of the wheels and are attached to the end frames and bridge plates projecting from the bridge girders. The vertical thrust of the axle bearing is taken upon heavy abutment plates, which are riveted to the bridge. The axle bearings are provided with grease boxes filled with woolen waste. One of the axles at each end is provided with a large gear wheel connected by a suitable train of gearing with a driving shaft extending the whole length of the bridge, supported in self-oiling, adjustable bearings, and the shaft is driven by a motor situated near the center of the bridge. The bridge wheels are 37 inches in diameter on the tread, with cast centers and steel tires shrunk on. The wheels are provided with double flanges. The use of such large wheels insures easy driving and the steel tires form a durable tread.

The trolley with its hoisting and traversing machinery runs upon rails within the bridge. The frame or housing is composed of built-up steel beams and plates resting directly upon the axle bearings. Upon its upper surface it carries the various bearings for the drum shaft and machinery. The trolley wheels are fast upon the axles and are 21 inches in diameter, steel tired, with double flanges. All the pinions in the hoisting train are of steel, and also the large gear-wheel on the drum. All high-speed gears have cut teeth. There are no bevels, worms or worm-wheels. The Sellers' well-known automatic retaining clutch forms a part of the hoisting train;

its action is positive and noiseless and it supports the load securely without any action on the part of the operator.

The hoisting drums have right and left-hand continuous grooves. The load is carried on four parts of one-inch chain, which is amply large for the work, and has a large factor within the limit of its test proof-load; it is of Bradlee & Co.'s special "D. B. G." grade. Two chains are used, one end of each being fastened to the drum and the other to a fixed point on the trolley by means of an eye-bolt, permitting the adjustment of the chains to equal length. The chains are laid so that the pressure is brought on each link in the direction of its greatest strength, and without tendency to deform the chain.

The hoisting drum and chains are arranged to wind in such a manner that the load must always raise and lower in a vertical line without tendency to twist the block or to traverse it sidewise, consequently the most delicate movements can be performed with certainty.

Each crane is worked by three two-phase alternating current motors of the Tesla induction type, furnished by the Westinghouse Electric and Manufacturing Company. A No. 4 motor is applied to each crane for hoisting and lowering, a No. 3 is used for bridge travel and a No. 1 for the trolley travel, six motors being used for the two cranes. These motors are similar in general to those used to drive the shops, except as to the winding. The crane motors are not of the constant-speed type, this feature being sacrificed to a certain extent in order to obtain sufficient starting torque in the lifting of heavy loads. The variation in the speed is about 30 per cent. from the normal of the constant speed motors of these sizes.

The motors operate on 400-volt circuits with two-phase currents having 7,200 alternations. Each motor has a Westinghouse controller placed within easy reach of the operator. Each motor has three fuses and a treble pole-knife switch.

THE PLANING MILL.

The planing mill was the subject of considerable study with particular reference to the arrangement of the machinery in order to avoid all unnecessary handling of material. This building is by far the most interesting of those of the car department, and it will be the only one described in detail.

By reference to the inset accompanying the previous article



Passenger Car Paint Shop Showing Stagings.

it will be seen that one of the yard tracks enters the north end of the mill and extends a distance of 100 feet into the building. This is for the purpose of taking loaded cars directly to the first machines upon which the heavy work of the mill is done. Power is supplied by a 125-horse power Armington & Sims engine, running at a speed of 268 revolutions per minute, located in the northwest corner of the power house and belted directly to the shafting of the mill. This is the only case in the whole plant where an engine is directly belted to its machinery and in this case advantage was taken of the favorable location of the mill for the direct connection. The shafting of the mill is in 12 transverse lengths spaced about

20 feet apart, except the three lines at the north end. All of the shaft lines except three have Worrall's clutches for the purpose of cutting out the friction of the shafts and belts that are not needed. The location of these clutches are indicated by the letter "A" on the plan of the mill. The planing mill shafting is 2 11-16 inches in diameter except the head shaft, which is 3 7-16 inches, and the lines of shafting are belted in series.

The mill is 300 feet long by 60 feet wide, which is a favorable shape for handling lumber in a regular course from the first machine to the last one used upon it, without either placing it upon the floor or retracting any of the movements. The location of the building is also favorable to economical operation, as it lies between the dry house and the car repair shops. It will be of interest to follow the programme of operations of certain materials passing through the mill. Side



Planing Mill from North End.

sills represent a class of parts to which intermediate and center sills, side plates and other long pieces belong. These are brought to the end of the shop on push cars or in car-load lots. The pieces enter the shop through a port hole through the wall in the northwest corner of the building, as seen in the plan. This port hole is provided with rollers over which the timber passes on its way to the large Berry & Norton four sided planer (indicated as No. 4 in the plan), which is placed 60 feet from the north end of the shop. Here the sills are planed on four sides to the required dimensions and the ends are cut off and squared on the cutting off saw, No. 3, 69 feet beyond the planer, the distance being sufficient for timber 70 feet long without backward motions. The timber next passes in a direct line to the bull-nosed tenoning machine, No. 2, where it is tenoned. It is then placed on horses and "laid out" or marked for further work, whereupon it goes either to the combination mortiser and borer, No. 1, or to the large hollow chisel mortiser and borer, No. 14, for finishing. It passes out of a port hole at the south end of the shop and is received on a push car for the car shop or loaded into a box car for shipment, as the case requires. It will be seen that the heavy timbers are neither laid on the floor nor zig-zagged about the shop, but pass in almost a perfectly straight path from end to end of the building.

It would be interesting to follow the course of draft timbers, which will be sketched very briefly. They enter the shop on push cars. They are planed on all sides by planer No. 4 cut off square at the ends on No. 3, tenoned on No. 2, gained as required and the boring and mortising are done on No. 33, which completes them. They pass out of the mill door on trucks.

Much of the heavy car work for the road will be done here and the handling of large quantities of such material as freight car decking has been admirably provided for. This material is generally two inches thick. It is brought into the mill on a flat car with an empty flat car in front of it. The decking is handed to the attendant of the large matcher, No. 32, who puts it through the machine. A helper hands

it to a laborer on the empty car, where it is loaded for shipment or for use in the repair shop. It would require much space to give the course followed by other parts, but enough is said to show the principle of labor saving employed here, and to call attention to the great importance of planning the arrangement of the machinery with a view of making every motion count in the finished product. Mr. John Chamberlain, Master Car Builder, kindly furnished the plan of the mill and Mr. E. T. Miller, Chief Draftsman in the Car Department, explained its operation. The location of the machinery is shown in the plan and its operation will be clear when the different uses to which the machines are put are considered. These are all indicated on the drawing.

The power plant and its electrical and steam power equipment, the heating and lighting systems will be described in the next issue.

(To be continued.)

REMOVABLE COVERING FOR LOCOMOTIVE BOILERS.

Whatever may be thought of the reasons for the breaking of locomotive staybolts, it is universally admitted that the drilling of test holes and frequent and regular inspection are

box between the running boards. The sections are framed in 1 1/4 by 1 1/4 by 1/4-inch angle irons, secured at the corners by 1/4-inch iron gussets, riveted to the angles. The two side courses are of fire felt 1 1/4 inches in thickness, while the longer course, going over the top of the fire-box, is made of the ordinary lagging with a sheet covering. The attachment of the sections is made by means of hooks riveted to the sheets and attachments to the running boards are made by means of bolts and lugs, which may be tightened to any desired extent.

In order to prevent the fire felt from falling out of the frames when removed wire netting of 1-16-inch soft iron wire with 3 by 3-inch meshes is woven into the angle iron frames, 1/4-inch holes being drilled through the angles for this purpose. The lengths of the sections of removable covering vary with the different types of engines, and this dimension is shown as "A" in the drawing. (The portion inside of the cab is put on separately, and when three feet or less in width two hooks are used, as shown in the drawing.) For the covering outside of the cab, when the distance "A" is less than 4 feet 6 inches the removable covering is made in one section, secured by three hooks at the top and by three clamps at the bottom of the sections. When the distance exceeds 4 feet 6 inches the

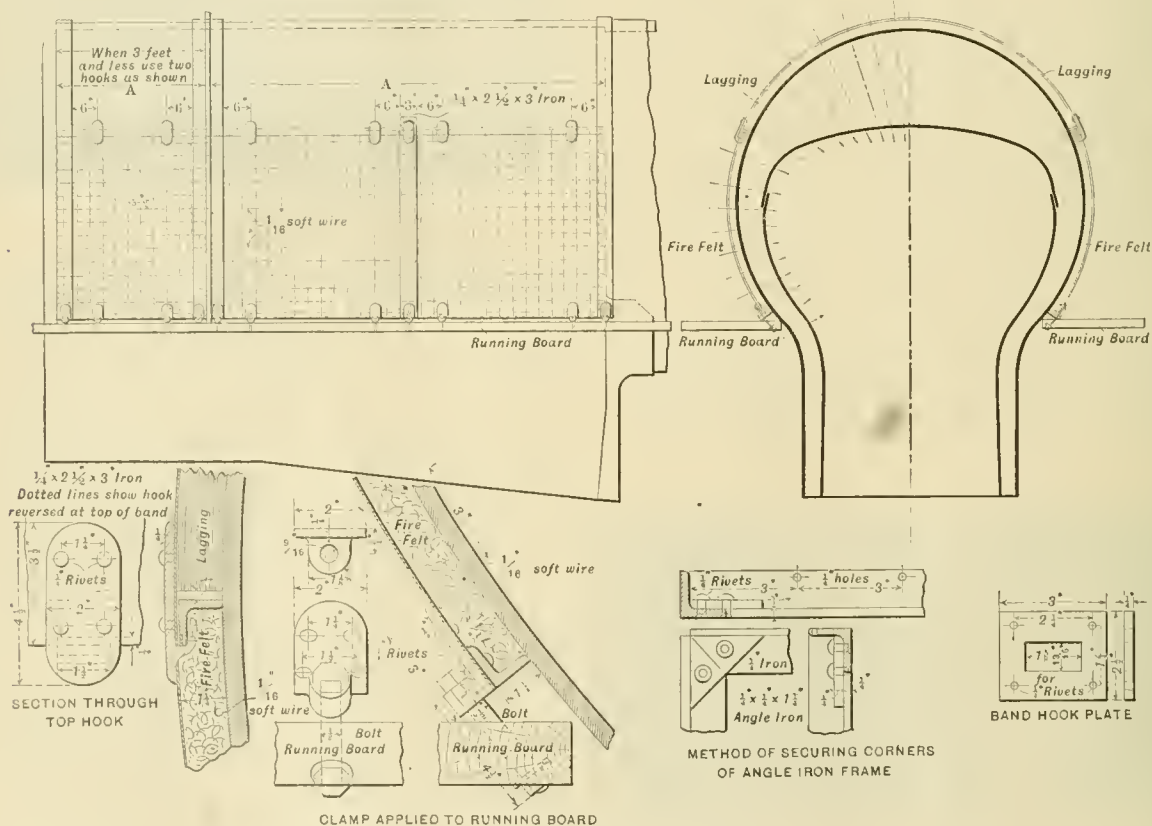

Removable Boiler Covering.—Northern Pacific Railway.

necessary to guard against their failure in service. In order to permit of easy examination of all the staybolts in the boilers of locomotives a plan has been adopted for removable lagging upon the Northern Pacific Railway, a drawing of which was kindly furnished by Mr. E. M. Herr, Superintendent of Motive Power of the road.

This plan consists in putting on the lagging over the fire-box, both inside and outside the cab, from the running board on one side to the same level upon the other side in removable sections. The object of the arrangement is to render the attachment and detachment of this lagging as easy as possible in order to decrease the difficulty of inspecting the staybolts. The lagging is made up in rectangular panels, three of which attached at their ends extend over the fire-

covering is made in two sections and secured as shown in the drawing. At the vertical joints between the sections, covering strips are provided, which are connected by hooks similar to those used in connection with the sections themselves. The details of the construction of the hooks and the frame require no further explanation. It is understood that this system of covering is applied to all classes of locomotives on this road.

In discussing the end of the great engineer's strike, our English contemporary, "The Engineer," says: "There is no longer anything to arrest the introduction of such systems of working as will augment and cheapen machinery, and so place us once more in a position to compete with the most go-ahead nation on the fact of the earth." This is a high compliment to the United States.

THE CONSTRUCTION OF A MODERN LOCOMOTIVE.

I.

By Motive Power.

Introductory.

Higher speeds, heavier trainloads, greater economy in fuel consumption and cost of running repairs, and consequent reduction of cost per engine mile, all more or less the result of competition, together with a keener knowledge of the locomotive and its peculiarities, have resulted in the development in this character of rolling stock of a machine which we will term a "modern" machine of its kind, capable of meeting these requirements, and vastly superior and different in much of its detail from the locomotive of years ago. A close observer of the various interests directly concerned with the construction of this type of machinery must have noted that, in a general sense, the progress or evolution from old-time methods to modern ones, born of the creation of the modern locomotive, is of far more recent date than that with which the locomotive of to-day is credited.

In speaking of the constructive side of the question, not only the construction of the engine itself must be considered, but this must be upon such lines as will have a direct bearing on the facility with which running repairs can be kept up and at a minimum cost. Independent of the efficiency of the engine or its economy in fuel consumption and in the interest of low cost of repairs the modern locomotive must be designed and constructed directly with a view of quick and cheap repairs in the roundhouse. Loss of time in the roundhouse will entail a proportionate loss of mileage and consequent earnings of the engine, and a great deal of this time may be saved by adopting designs and methods and a system of construction bearing this phase of the question in mind. Interchangeability of parts, ease of removal of defective parts and replacement of new ones, character of material and workmanship are potent factors in this line of economy.

It is not our purpose to describe the modern locomotive, but rather to deal with its construction, following such modern methods as have been found successful and which bear relation to the points referred to above; nor is it our intention to emphasize the question of cost of manufacture; locality, facilities, price of labor all having a direct bearing on the cost. Questions of methods, rather than cost, will be considered. In the construction of a modern locomotive, and considered from a standpoint of manufacture, the questions of superintendence, raw material, labor, fixed charges and output are vital to the successful operation of the plant, and its organization or subdivision of labor should be such as will provide the minimum number of departments consistent with careful supervision of the force employed in each, and with a view of keeping at a low figure percentage for supervision charged on output.

We desire at this point to impress upon the mind of the reader that he may thoroughly appreciate the aim which we have in view in the following articles, that the most perfect system and complete in its detail is not always the most economical, and that, from the standpoint from which we are going to consider the question, that system is the most economical which has the least amount of detail, requires the least amount of clerical labor, and in its working requires or encourages the least amount of repetition; at the same time providing, in the working of all of its departmental functions, a complete and connective chain of evidence for the purpose of record. In articles which will follow the various departments which we consider necessary for the successful carrying out of the economical construction of the modern locomotive will be considered in detail and under their respective headings. Inasmuch as the system which we propose is entirely controlled and operated by and from the office, that portion of the plant will receive our first consideration.

Office, Drawing Room and Storehouse.

The general arrangement of the plant, governed by the

acreage or shape and size of the land on which shops are built, will frequently decide the question of office, drawing-room and storehouse being under one roof. It is, however, our opinion that, as far as the storehouse is concerned, it should be located as near to the shops in which the material is used as possible, and at the same time convenient to siding or track room for the unloading and the shipping of material. For the purpose of making the matter more comprehensive, however, we will consider the office to include the drawing room and storehouse. The office will be considered as divided into three principal departments:

First, the office proper, containing the general office, superintendent's office, with necessary clerks, etc., in which will be conducted all of the general and supervisory business of the plant, and from which all orders and instructions will be issued, and the ordering of all material will be provided for; also a separate or accounting department, coming under the direct supervision of a chief accountant or clerk. In this department all of the accounts and time records of the plant will be kept, pay rolls, bills and costs made out, and such special and general reports and records provided for as shall be deemed advisable by the superintendent. This department should also have charge of all the detail in connection with the paying off of the men employed at the works.

Second, the drawing room, in which should be kept all drawings pertaining to the plant and work under construction; it should be equipped with the necessary force for carrying on such work as would properly belong to this department, and be in direct charge of a competent person, who shall report to the superintendent. As will be hereafter explained more in detail, the drawing room should make out all lists for material, provide piece-work prices, and in a general way furnish from its records and drawings all of the necessary information for the ordering and purchase of material by the general office, as well as the manufacture of that material into the finished product by the shops.

Third, the storehouse, to which should be delivered, either actually or nominally, all of the material received at the works, provided with ample space, shelves and other facilities for the storing of such material of value and of such size as to render it inadvisable to store at other points or in the open air. The storehouse should have full charge of all material received at the plant, whether actually stored within its four walls or at various points throughout the works, and this material remain in the custody of the keeper of stores, who should have full charge and report to the superintendent until it is withdrawn from stock on proper warrant issued to the foreman by the general office. The warrant, on presentation to the keeper of stores, will be a record kept by him of material delivered to any one department. This department should also have full charge of all shipping and should make its reports to the general office. Monthly records of stock on hand and daily records of stock received and consumed are kept in this department. Certain classes of material will of necessity be stored at various points throughout the works where it can be conveniently unloaded, it is thoroughly practicable to have a man in charge of this material, as if it were included in a building, and have his office located at a point near to where the bulk of this material is stored. After the manner of handling stock which is included in the storehouse proper, this material shall be drawn from his custody on the presentation of proper order cards or the ordinary verbal communication on the part of the foreman where the right on the part of the foreman to have this material is demonstrated by its specification on the list in the hands of the man in charge of it. This man should report to the keeper of stores and be under his direct supervision. In this connection it is understood that no material of any kind can be stored under the supervision of any one of the departments outside of the storehouse unless it has been drawn from stock on warrant issued from the general office, and those warrants specifying the order for which it is to be used. Too much stress cannot be laid on the care and storage of raw

material; not only its mere storage, but storage in such a way that the various kinds of material are kept separate, and records of quantities on hand and quantities consumed in any one month provided, which are of such nature that their reliability are beyond question.

Inasmuch as all of the construction in a well-regulated shop is carried on from drawings, it quite naturally follows that a well-conducted drawing room, bearing proper relation to the general office and shops, as it will be shown to bear in these articles, becomes not only an exceedingly important, but one of the first departments in the works to carry out any portion of the system bearing on the construction of the work in hand, and for the purpose of illustration we assume that complete drawings have been prepared for a standard or modern locomotive, and that they have been approved or passed upon by the superintendent of the works as the drawings to be used. These drawings need not exceed, for the large size, 12 by 18 inches, and it has been found that two sizes smaller than this, each a multiple of the larger one, are ample for all purposes. As far as possible, and consistent with the arrangement of departments, these drawings should illustrate groupings of the different operations performed and the different kinds of material used in the various departments, with the distinct purpose in view of avoiding as much duplication of drawings as possible; in other words, it is desirable, as far as possible, to supply each department with drawings illustrating entirely and only the particular part of the work which it has to do.

All drawings should be subject to the approval of the superintendent, generally requiring his signature. They should be clearly dimensioned, but only such dimensions put on as are required in the shop, and it should be distinctly borne in mind that the men who use these drawings are not expected to be mathematicians. Total dimensions over all should be provided and put on the drawings in the drawing room; and it should never be necessary in the use of the drawings in the shop that the men themselves should be required to add or subtract for the purpose of determining an intermediate dimension. Each drawing should contain a note to the effect that any absence of dimension information concerning it must be had from the drawing room before the work progresses further, and under no circumstances should a scale or rule be used for the purpose of determining a missing dimension on a drawing; and in fact, it has been found entirely unnecessary to make any of these drawings to scale. Dimensions should not be changed or placed on the drawings in the shops; where changes or additions are necessary the drawing room should be notified and the changes made there. Where a finish is to be made to gauge a note should be added on the drawing to that effect and the number of the gauge given. Kinds of material should be distinctly specified, and in the case of castings the pattern numbers should be given, or of forgings the forging numbers given. It has been found to be a good plan also to put a note on the drawings to the effect that the number of pieces specified on that drawing are the number required for one engine. The date the drawing is issued, and if it is a detail made from a larger drawing, the number of that larger drawing and its issue, should be inserted. The particular class of engine for which the drawing is prepared can be put on the outside margin, and a blank space, arranged so that it will print white, can be left in the title for the insertion of another class for which it may be desirable to use the drawing. A small black dot on the tracing, and which will print white on the blue print, for the purpose of inserting a shop initial, has been found convenient as a means of preventing the exchange of drawings from shop to shop and their being lost; not because of the value of the drawings themselves, but because, in the event of change of design and the intention to withdraw from the shops drawings which are obsolete to prevent mistakes, they can be traced and returned to the drawing room.

Where changes of design are necessary during construction, the existing drawing should be called in and a new one issued

showing such change and a note made on the old one to that effect, giving the number of the new drawing taking its place. The new drawing should also contain an appropriate note indicating that fact, and where special instructions have been issued on the part of the superintendent or the customer for whom the engines are being built, reference can be made on both drawings to the letter or communication, which referred to the change so made. The old drawings should under no circumstances be destroyed, but kept on file. All drawings issued to the shops or to any department of the works should be entered on some form of receipt and receipted for by the foreman of the department to which the drawing goes. These receipts can be printed on a small card, with blank spaces for the entry of the particular drawing and a space for the foreman's signature; the date on which the drawing is issued to the foreman should also be put on this card and a special space across the end of the card left blank provides for the entry of the date of its return. These cards are kept in the drawing room in special compartments, corresponding to the division of the departments of the works, so that at any time an inspection of the cards under any one department will indicate the number and kind of drawings which that department may have, unless it be the case that the cards indicate the drawings as having been returned, in which case the cards will be kept in a separate compartment. These cards are kept on file for one year and then destroyed.

The drawings, being of small size, can be readily mounted on either tin or sheet iron and varnished, and in this way are very serviceable. At the completion of an order it may be convenient to call in a great many of the drawings and remove the prints from these metal backs, using them for the new series. It will, of course, be obvious that in many cases in connection with locomotive work parts are similar in general outline and only vary in dimensions, in which case the dimensions on the drawing proper can be lettered and the various dimensions for different classes of engines tabulated in such way as to reduce the number of drawings which would otherwise be necessary. Fig. 1 illustrates one of the drawings referred to and Fig. 2 a form of receipt card, which will be found satisfactory.

MODERN LOCOMOTIVE COMPANY.		
.....	189..
Please furnish for use in		Shop.
for work on Class	Locomotives
.....
Furnished	189
Number.....
Drawer
		Foreman.

Fig. 2.

Returned.....189..

Possessing, as it does, more complete information regarding the requirements in the way of material and parts than any other department of the works at this stage, the drawing room is required to furnish the general office with the necessary information for the proper ordering of material and parts required, and for this purpose prepares, so that prints can be taken, a list, the headings and vertical divisions of which are shown in Fig. 3. The information on these lists is secured from the drawing room and also from foremen of departments, so that, in their complete form, they contain, in the strictest sense of the word, all of the material required for an engine. In some cases, as, for instance, lumber, nails, paint, varnish, etc., the amounts given on the list for the first order of engines must of necessity be approximate, but by the arrangement of material and credit cards, which will be hereafter explained, any excess can be returned to stock and proper credit given. We would state here that these lists, in their complete form, in the form of prints issued to the general office as information for ordering material, are used in the storehouse for checking up the receipt of material and also govern-

ing the amount of material which can be drawn by the shops. They are also issued to the head of each one of the departments and are a guide to them for the material which they will ask for and draw from the storehouse. This will explain the large number and variety of headings provided, as illustrated in Fig. 3. In the case of the general office, the "Number of Pieces per Engine," "Number of Pieces Ordered," "Kind of

next class from 3,000 to 3,999, and so on; or symbols may be used to designate separate classes; this being purely a matter of preference, may be decided accordingly. Owing to the fact that it is considered advisable to do all of the bolt and stud work in a separate and distinct department, which will be hereafter described, the bolts and studs required on an order of engines are included on a separate list, which is similar to

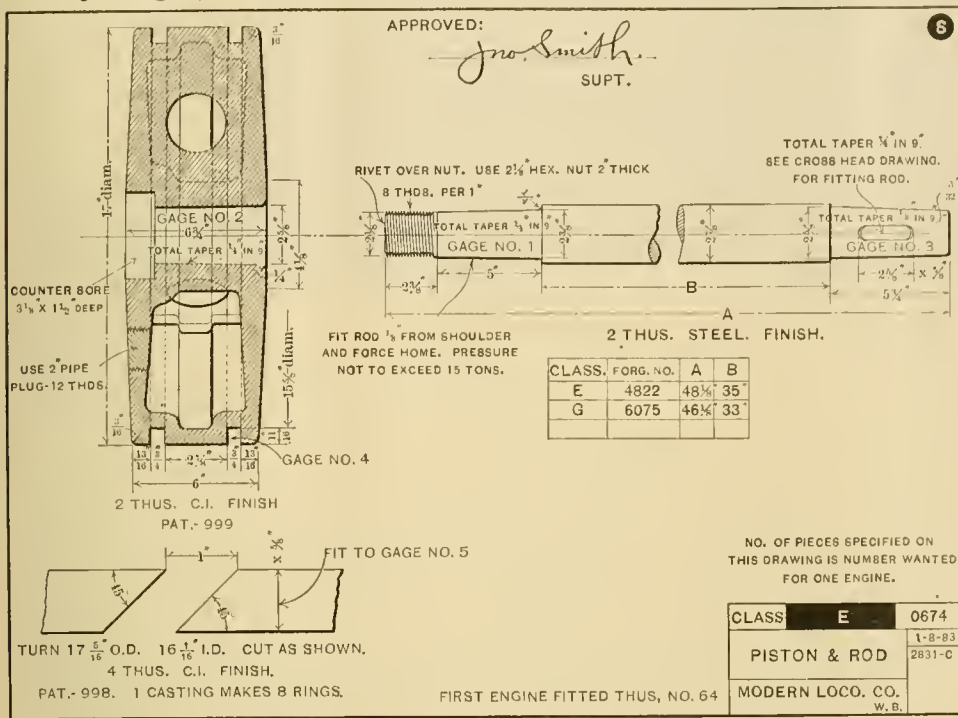

Fig. 1.

Material," "Pattern Number," "Drawing Number," "Requisition Number," "Where From," "Ordered On," etc., are important. In the case of the storehouse, similar headings, with "Price Per Unit," "Total Cost," "How Received" and "When Added" are particularly useful. In the case of the shops the "Number of Pieces," "Pattern Number," "Name of Casting or Forging" or "Number of Forging," "Weight Rough" and "Weight Finished," "Drawing Number," "Planing," "Boring," "Slot-

drawings becomes a species of stock to draw from, and that any drawing, although for an entirely different class of engine, can be specified on a list for a different class of engine.

For the purpose of keeping record of the scrap per engine as a result of machine work, the columns "Weight Rough" and "Weight Finished" are provided, and according to the work done in each department, this information will be filled in by that department on the respective lists. At the comple-

No. of pes. per eng.	No. of pes. ordered.	Kind of material.	Forg. No.	Name of forging.	Drawing No.	Schedule.	Ord'd on.	Req. No.	Where from.	How re-ceived.	When re-ceived.	Forging.	Sawing.	Planing.	Turning.	Boring.	Slotting.	Milling.	Drilling.	Grinding.	Hand fin-ish.	Wt. rgh.	Wt. fin.	Price per unit.	Total cost.
2	10	W. I.	3,006	Main frames.	284	A-1	S				3, 6, '93	141.00		4.00			8.50		3.25			1,201	912	.01	168.76
2	10	Steel	3,007	" rods.	396	C 1	S	376-A	A B. & Co.	Fr't. hurried	4, 1, '93	5.50		1.90	1.00		4.50	5.80	3.00	.75	10.90	352	119	1.2	57.57

Remarks: See Bloom Steel Req. 376-A. List .0352.

Approved:

Order for 10 eng's.

Class D .0441

JOHN SMITH, Supt.

Work order 246

Forging list. 1-3 '92

Issued 1-7-'92

Modern Loco. Co.

Fig. 3.—(There should be about 35 horizontal blank lines in this form.)

ting," Milling," "Drilling," "Grinding" and "Hand Finish," are useful.

For the purpose of saving an unnecessary amount of writing and the misunderstandings which may occur due to the different names given to the same thing by different people, all of the forgings, bolts and studs required on the engine are numbered; and the various classes of engines may be, if desired, designated by an additional thousand, one class of engine running from 2,000 to 2,999 for its forging numbers and the

tion of the order of engines all of the lists in the various departments are returned to the office, and the difference between the totals of these two will give the amount of scrap. In the case of the storehouse the price per unit and the total cost is entered from time to time under those respective headings, and at the completion of the order the storehouse lists are returned to the accounting department to be used in making up costs. On each set of complete lists before being issued to the different departments is placed the work order number to which

all work done and material used is to be charged for the information of the heads of departments. It will be obvious that any other information which it may be advisable to have may be inserted on these lists at this time. The lists in the general office at their completion will contain all of the order numbers and such other data and information as directly pertains to the ordering of material and one record of its ordering, and at the completion of the order the lists which belong to the general office are filed with this information on them and become a record of that particular order of engines. The lists which have been returned from the shop, after the information concerning weight rough, weight finished, etc., has been taken off, may be destroyed. It will be obvious that in course of time and because of the construction on repeated orders of a large number of the same class of engines the information weight rough and weight finished may become a permanent entry on the tracings of the lists from which prints were made. Before orders for material are made out in the general office the stock on hand which may be used for that particular order of engines is carefully checked with the amount called for on the lists and the difference or what is required ordered. This amount is entered by the general office under the heading "Number of Pieces Ordered." Entry can also be made on the face of the list of the number of pieces found on hand at that particular date; as this information is only interesting to the general office, no special column is provided for this purpose.

The columns headed respectively "Planing," "Boring," "Slotting," "Milling," "Drilling," "Grinding" and "Hand Finish" are intended to indicate respectively the prices paid for each one of those operations on that particular piece opposite to which the price is placed, and those prices are filled in by the drawing room in connection with the foreman of the department in which that work is done. These prices should be the result of very careful consultation with the foreman of that department and a complete knowledge of the limit of his facilities. Enough has been written concerning the establishing of piece work prices to make it unnecessary to comment on the method which can be followed in this case. Suffice it to say that we consider that all of the operations indicated in the headings on the list can be distinctly determined on a strictly mechanical basis and according to the capacity of the machine, and that planing and slotting can be paid for on a basis of so much per square inch, drilling on a certain included range of diameters of holes per one inch of depth, and the other operations in similar manner.

(To be continued.)

TEN-WHEEL PASSENGER LOCOMOTIVE—SOUTHERN RAILWAY.

The Richmond Locomotive Works have just completed and delivered to the Southern Railway two large and heavy simple passenger locomotives. These engines are of the ten-wheeled type and weigh about 158,000 pounds in working order. The general appearance of the engines is seen from the illustration reproduced from a photograph kindly sent us by the builders. We are also indebted to them for drawings of special features herewith shown.

The engines are from designs of Mr. W. H. Thomas, Superintendent of Motive Power of the Southern Railway, and are the result of careful study of the needs of the heavy service required for the "Southwestern Limited," which is a heavy and fast train, and owing to the very long and heavy grades on portions of the run, the necessity for engines that will make fast time up hill was felt. Recent trials of these engines were very satisfactory.

The boilers are of the extended wagon-top type, with radial stays and fireboxes over the frames, the working pressure being 200 pounds per square inch. The heating surface is 2,410.17 square feet, and the grate area 34.9, the ratio being 69.5 to one. This is a very ample heating surface. The cylinders are 21 by 26 inches, the driving wheels 72 inches over the tires, and

the driving journals are 8½ by 11 inches, running in solid bronze driving boxes. The eccentric straps are also of bronze. The driving and engine truck axles and crank pins are of steel. The swing hangers for the engine truck are arranged in such a way as to make use of the hangers on both sides of the truck to resist the side motion on curves, and to tend to return the truck to its normal position after passing the curve. This feature is shown in the drawing of the truck hanging arrangement, in which it will be seen that the upper support for the hanger is on two pins instead of one. Ample motion is provided for, and this plan is expected to reduce and prevent swinging and "nosing" on tangents. The driving springs are underhung with rods through the boxes.

The valve gear is also worthy of special notice; it is designed to dispense with the very objectionable "long eccentric rods" formerly used in this type, and also to avoid the complicated style of gear that was designed to replace the long rods by substituting an intermediate or motion bar to clear the forward axle and using very short valve stems. It will be seen by referring to the drawing that a very long valve stem is used on these engines, which is supported by a bearing on the yoke, while at the same time the link is hung so far forward that a fair length of eccentric rod is obtained. The rocker derives its motion from a "return bar," and the whole device is substantial and compact, but not complicated.

The main and parallel rods are of steel "I" section with solid ends, except back end of main rod, which is fitted with a triple-bolted strap. The crossheads are of steel castings, made solid and tinned on all bearing surfaces, and the pistons are fitted with the usual taper and secured by jamb nuts, dispensing with keys and key slots. The cylinders are secured to the smoke box by double bolting around the flanges, the bottom of the smoke box being reinforced by a ½-inch steel plate to take bolts. The steam and exhaust pipes have four and six bolts, respectively, at the joints, and every precaution has been taken to prevent the working or moving of parts from lack of proper fastenings, or poor workmanship in fitting. Owing to height of the boiler, a special dome is designed to take the safety valves and whistle. The throttle valve, which is the Southern Railway's standard, is placed in the main dome.

Westinghouse-American equalized brakes are applied to all driving wheels, and Westinghouse automatic brakes to tender wheels. Automatic signaling device, Golmar bell ringer, Leach's sanding device and other modern appliances are used on these engines.

The tender tank is of 4,500 gallons capacity and ample coal space is provided.

The tender has a heavy steel channel tender frame and Southern Railway standard trucks. The rear of the tender has a Janney-Buhoup three-stem coupling and the pilot has a Janney coupler and Southern Railway standard fastenings. The principal dimensions follow:

General Description.	
Type of engine.....	ten-wheel simple
Class of traffic.....	fast passenger
Gauge.....	standard
Fuel.....	bituminous coal
Running Gear.	
Driving wheels, diameter.....	72 inches
Truck wheels, diameter.....	36 inches (McKee Fuller steel tired)
Tender wheels, diameter.....	38 inches
Journals, driving axles.....	8½ by 11 inches
" " truck axles.....	5½ by 10 inches
" " tender axles.....	4¼ by 8 inches
Wheel base, driving.....	14 feet 7 inches
" " truck.....	6 feet 9 inches
" " total engine.....	26 feet 1 inch
" " tender.....	17 feet 3 inches
Weight in working order, on drivers.....	121,250 pounds
" " " on truck wheels.....	36,750 pounds
" " " engine, total.....	158,000 pounds
Cylinders.....	21 by 26 inches
" " distance center to center.....	.87 inches
" " piston rod, diameter.....	.33½ inches
" " guides.....	2 bar type
" " connecting rod, length between centers.....	10 feet 4 inches
Valve gear, type.....	shifting link motion
Valve ports.....	length, 19 inches; width steam, 1¾ inches; width exhaust, 3 inches
Boiler, type.....	extended wagon-top radial stay
" " diameter of barrel inside.....	.60¾ inches
" " thickness of barrel plates.....	¾ inches
" " thickness of smokebox tube plate.....	½ inch



Ten-Wheel Passenger Locomotive—Southern Railway.

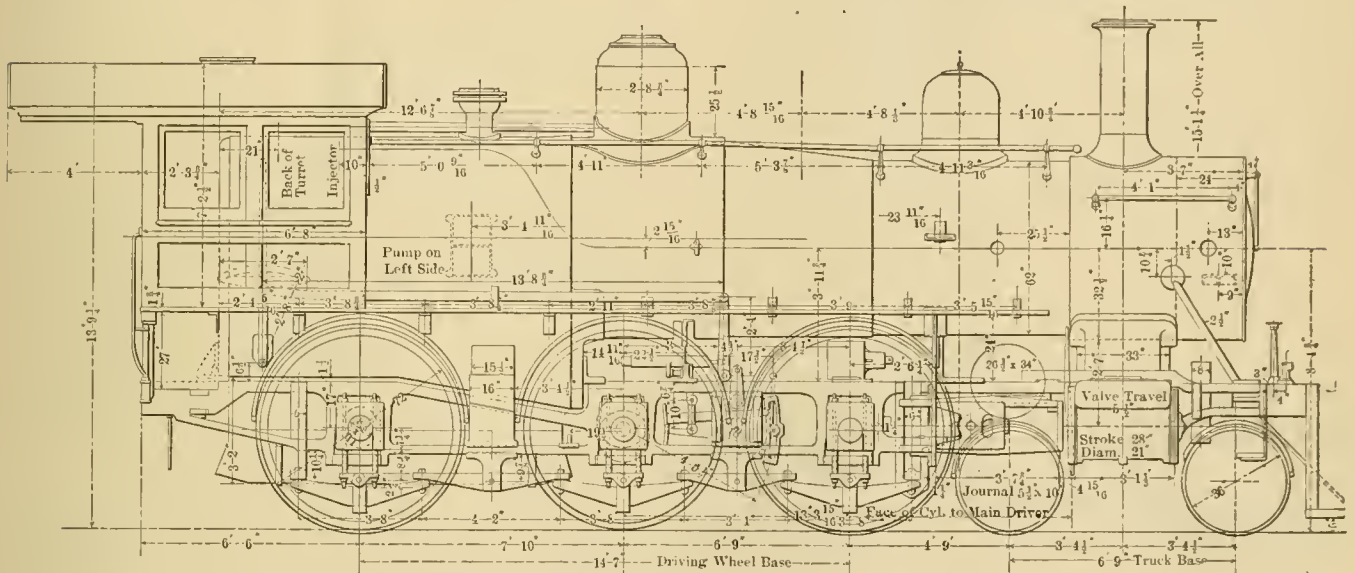

Ten-Wheel Passenger Locomotive—Southern Railway.

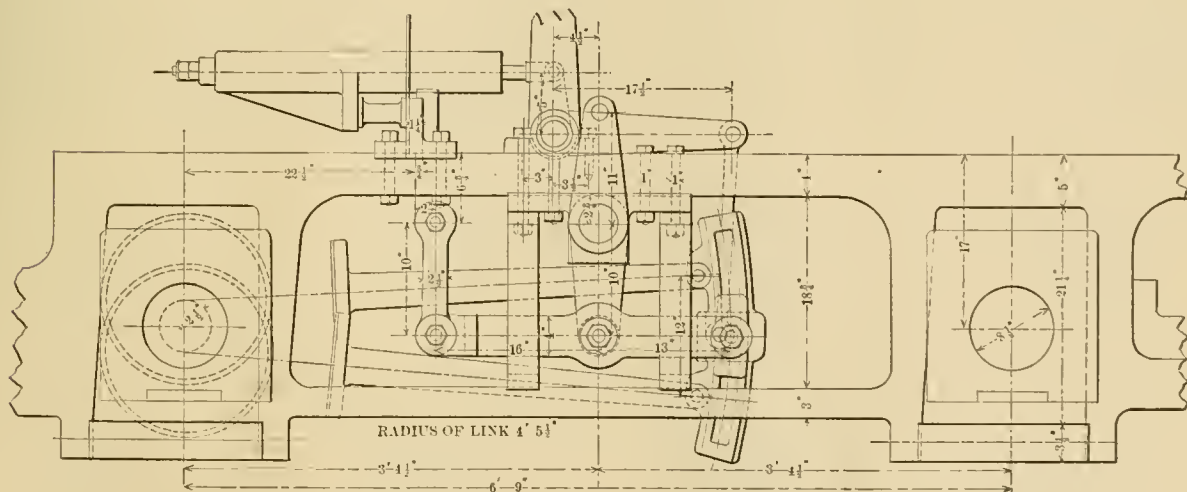

Valve Motion—Showing Connection Between Links and Rockers.

TEN-WHEEL PASSENGER LOCOMOTIVE—SOUTHERN RAILWAY.

W. H. THOMAS, Superintendent Motive Power.

RICHMOND LOCOMOTIVE & MACHINE WORKS, Builders.

Boiler, height from rail to center line.....	8 feet 4 1/4 inches
" length of smokebox.....	5 feet 8 3/16 inches
" working steam pressure.....	200 pounds
Firebox, type.....	wide, with forged down frame
" length inside.....	10 feet
" width inside.....	3 feet 5 7/8 inches
" depth at front.....	6 feet 3 inches
" depth at back.....	5 feet 1/2 inch
" thickness of side plates.....	3/8 inch
" of back plate.....	3/8 inch
" of crown sheet.....	3/8 inch
" of tube sheet.....	1/2 inch
" staybolts.....	1 1/8 inch diameter, 4 1/4 inch pitch
" water space, back and sides.....	3 1/4 inches; front, 4 inches

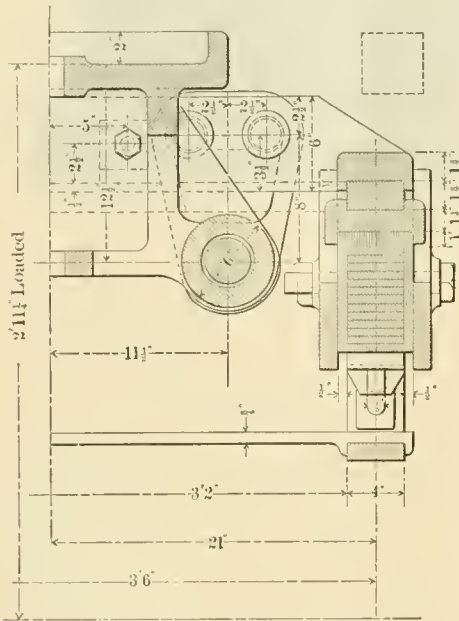

Engine Truck Suspension.

Tubes, material.....	charcoal iron, number, 295
" diameter outside.....	.2 inches; No. 12 B. W. G.
" length between tube plates.....	14 feet 4 1/4 inches
Heating surface, tubes.....	2,217.16 square feet
" firebox.....	192.96 square feet
" total.....	2,410.12 square feet
Grate area.....	34.9 square feet
Miscellaneous.	
Exhaust nozzle, diameter.....	5 1/8 inches
Smokestack, smallest diameter.....	16 inches
" height from rail to top.....	15 feet 1 1/4 inches
Capacity of tank.....	4,500 gallons

THE GREAT NORTHERN MASTODON LOCOMOTIVES.

In our January and February issues, a number of interesting features of the two Brooks mastodon locomotives for the Great Northern Railway were presented, and to these some further notes are added.

The piston valves of these engines have some features which

are worthy of special attention, and they should be examined by those who are considering the employment of valves of this type in future designs. Attention has already been directed to the bushings within which the valves move, and in one of the engravings shown herewith it will be seen that the packing rings for these valves are quite novel. The main packing ring is very wide and thin, it is so shaped that it cannot catch in the ports and for this reason a reduction in the number of bridges may be made. This is important because of its effect upon the passage of steam, and it seems probable that some such plan may be the means of avoiding the ob-

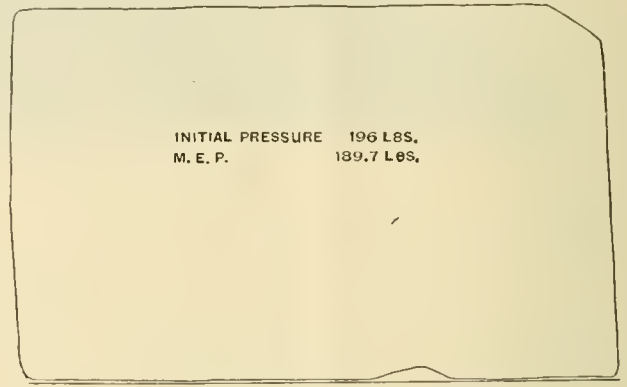

Card No. 1.—Full Size.

M. E. P. 12.5 LBS.

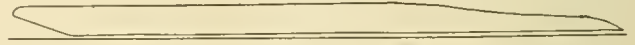

M. E. P. 13.7 LBS.

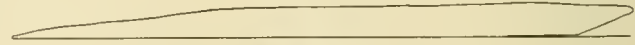

Cards from Engine Running Light.

M. E. P. = 6.5 per cent. of Initial Pressure.

struction to the steam which to some has appeared as a serious disadvantage in connection with piston valves. Another feature of this packing ring construction is that the edge of the valve which controls the admission of steam is clear of the end of the valve. This is new and it will probably tend to still further reduce the resistance of the steam by admitting it directly into the ports without causing eddies around the end of the barrel of the valve, which must occur to some extent when the packing rings are removed from the ends of the valve. There are three packing rings, each cut in a different

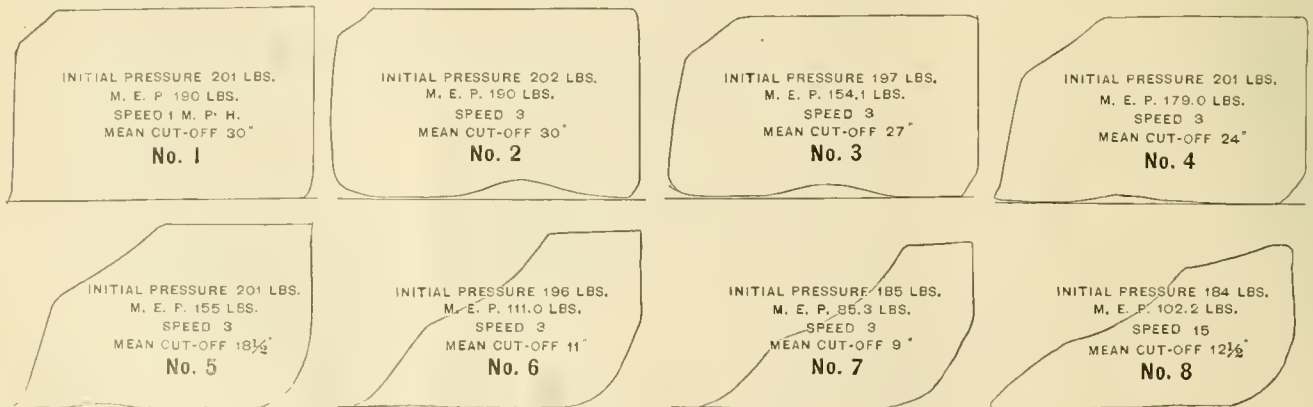

Indicator Cards—Great Northern Mastodon Locomotive.

Ratio of M. E. P. to Initial Pressure—Card No. 1, 96 per cent.; Card No. 2, 94 per cent.; Card No. 3, 94 per cent.; Card No. 4, 89 per cent., Card No. 5, 80 per cent.; Card No. 6, 59 per cent.; Card No. 7, 48 per cent.; Indioated Horse Power, Card No. 8, 1090

lies in the fact that after an engine is out of the shop nine months its rating is reduced; that when twelve months out another cut is made, and when fifteen months in service a third reduction of tonnage is considered necessary. Judging from my experience these reductions are not warranted. We have many engines that make over 100,000 miles between shoppings and haul full trains up to the last trip before entering the shops. It will usually require at least two years to make this mileage, but we make no provision at any time in that period for reducing the tonnage assigned to the engine. Furthermore, we have had in the last six months probably thirty cases of engines that have made over 130,000 miles between shoppings, and were hauling full trains to the very last. This is accomplished by doing thorough roundhouse work. We are trying to get large mileage out of our engines between general repairs and think that we ought to get from 80,000 to 100,000, depending upon the class of the engine; but if an engine is not rendering satisfactory service to the operating department, its place is in the shop, and not on the road, and we take it in as soon as possible. If its mileage is small, it will generally be found that the repairs needed to put the engine in condition will not be heavy. Surely it will pay to carry out this policy, and by this means keep up the tonnage rating. It may slightly increase the cost of repairs per engine mile (although I don't think it will), but the cost of repairs per 1,000 ton miles will be less, and that is the only correct basis on which to work, though I am sorry to say that our accounts are not kept on that basis.

It is our practice to have only two or three ratings for an engine on any one part of the road, these ratings being based on the speed the trains are desired to make. The dead freight rating is, of course, the heaviest, as the speed of this class of trains is the slowest. While intended primarily to meet the different speeds required, the different ratings are also used quite frequently to meet the different weather conditions. The plan is simple, and has worked well.

PROVD.

February 15, 1898.

STEEL CARS OF LARGE CAPACITY.

One of the most important of railroad transportation subjects of the time is the effect of steel cars of large capacity upon the earning power of the roads, and three articles which appeared in our issues of December, 1897, page 419; January, 1898, page 19, and February, 1898, page 55, present some ideas upon the questions involved.

Recent orders for cars of 100,000 pounds capacity or more show the tendency in this direction, and it is of interest to note the following substantial lots of cars which are being built by the Schoen Pressed Steel Company. These, in addition to the cars built for the Butte, Anaconda & Pacific, and the 1,000 cars for the Pittsburg, Bessemer & Lake Erie, make a remarkably good showing. The new orders are as follows:

Two hundred coal and ore cars, Pennsylvania Company, 110,000 pounds capacity.

Four hundred and fifty coal and ore cars, Pittsburg & Western, 100,000 pounds capacity.

One hundred coal and ore cars, Pittsburg & Lake Erie, 100,000 pounds capacity.

Forty ore cars, Lake Superior & Ishpeming, 100,000 pounds capacity.

All of these cars are self-clearing, and will be built from the plans of Mr. Charles T. Schoen. The diamond pattern of pressed steel truck, which the Schoen Pressed Steel Company manufacture, will be used under all of these cars. The Pennsylvania and Pittsburg & Western cars are to be used for hauling coal to the lakes from Pittsburg and bringing back ore, and are to have journals 5½ by 10, while the others have 5 by 9-inch journals.

These orders, coming only after most careful inquiry and investigation into the merits of the steel car by officials of roads known to be most conservative, practically settles the future of the steel car. None of these cars will weigh over 34,000 pounds, notwithstanding their great carrying capacity, and those for the Lake Superior and Ishpeming only weigh about 20,000 pounds. They are only 22 feet long and are designed especially for the Lake Superior iron ore trade, the hoppers being arranged to unload into pockets at the docks, which are only 12 feet apart.

Mr. Schoen says: "So general has become the inquiry concern-

ing the steel car that we cannot but feel that transportation officials have begun to realize in earnest what a large money saving can be obtained from its use, the gain on account of reduction in dead weight and the saving in cost and maintenance alone being exceptionally great."

The fundamental underlying thought of the designer and the company building these cars was: Is it possible to build a steel structure of this character as cheap per ton carrying capacity as a well-designed modern wooden car? This has been accomplished by the expenditure of a very large amount of money in plant and a very economic design of car in so far as weight and workmanship are concerned. It has been clearly demonstrated that a steel car adapted for hauling fixed car loads or fixed train loads of material can be built entirely of steel as cheaply per ton of carrying capacity as a wooden car of modern design.

The importance of saving of dead weight in cars is a subject that has frequently been commented upon and admits of little or no question. How to show the value of this saving, however, in actual dollars and cents, has been found most difficult.

We give below a statement showing this, which we believe to be approximately correct, and have combined with it a statement showing the saving in cost and maintenance of a modern steel car, as built by the Schoen Pressed Steel Company, as compared with a wooden car. For the sake of easy reference we have divided the statement into two parts, viz:

First. Saving in cost and maintenance.

Second. Gain due to saving of dead weight.

STATEMENT NO. 1.

Saving in Cost and Maintenance.

The comparison of cost between 30-ton wooden car and 50-ton modern steel car includes interest and cost of maintenance for the life of each car respectively. The cost of repairs to the wooden car is averaged at \$40 per year throughout its life of, say, 15 years, and of the steel car at \$20 per year throughout its life of, say, 30 years.

Wooden Car.	Modern Steel Car.
Cost, new	Cost, new
Interest, 15 yrs., at 6 p. c. ...	Interest, 30 yrs., at 6 p. c. ...
Repairs, \$40 per year, 15 years	Repairs, \$20 per year, 30 years
Cost for 15 years.....	Cost of steel car for 30 years
Double this amount and you have the cost of wooden car for 30 years.....	This means a cost of \$95.60 per year during the life of the steel car, or \$1.91 cost per year per ton carrying capacity.
This means a cost of \$106.50 per year during the life of the wooden car, or \$3.55 cost per year per ton carrying capacity.	
Difference in cost per year per ton carrying capacity in favor of steel cars, \$1.64, which is equal to 46.2 per cent.	
If this \$1.64 be multiplied by 50 tons—capacity of steel car—it shows a saving per steel car per year of.....	\$82.00
At \$32.00 per steel car per year 500 steel cars will save per year	\$41,000.00
At \$41,000 saved per year 500 steel cars for 30 years will show a total saving of	\$1,230,000.00

STATEMENT NO. 2.

Gain Due to Saving of Dead Weight.

Assuming that trainloads of 1,500 tons of paying freight are hauled, and that the wooden car weighs 16½ tons and the steel car 17 tons:

To haul 1,500 tons, 50 wooden cars are required, weighing.....825 tons
To haul 1,500 tons, 30 steel cars are required, weighing.....510 "

Dead weight saved per trainload in favor of steel cars.....315 tons

If 500 steel cars are used, it will give 16 2-3 full trainloads, which, multiplied by 315 (tons of dead weight saved per train), gives 5,250 tons of paying freight gained for each run of the 500 steel cars.

In estimating the actual cost to a railroad company for hauling ore to, and coal from, Pittsburg to the lakes, many difficulties are met with. We have assumed, however, for the purpose of this comparison, a cost of 15 cents per ton in each class of cars:

5,250 tons of paying freight gained for each run of 500 steel cars, at 15c. per ton, equal.....	\$787.50
If the cars make 30 runs per year, this gain is \$787.50 by 30, equal	\$23,625.00
Thirty round trips (equal to 60 runs one way), per year, \$23,625 by 2, equal	\$47,250.00
Gain in 30 years, due to saving of dead weight alone, \$47,250 by 30, equal	\$1,417,500.00

Recapitulation.

Saving in cost and maintenance, Statement No. 1.....	\$1,230,000.00
Gain due to saving of dead weight alone, Statement No. 2. ..	1,417,500.00

Total saving effected by 500 steel cars in 30 years.....\$2,647,500.00

CONDENSERS FOR SHOP ENGINES—CHICAGO, MILWAUKEE & ST. PAUL RAILWAY.

The water supply at railroad shop plants is frequently obtained at considerable expense because of the large amount of water required for the shop engines and for round houses, which are usually located near the shops. Especially is this true where it is necessary to wash out boilers frequently. It is unusual to employ condensers in connection with stationary shop engines and it is believed to be worth while to consider whether some such plan as that in use at the West Milwaukee shops of the Chicago, Milwaukee & St. Paul Railway is not applicable elsewhere. This system was devised to save expense and to make use of condensers in connection with two shop engines which are separated by a distance of several hundred feet and at the same time to furnish a supply of hot water for washing out locomotive boilers in the round house.

night for use during the day. These tanks are located very near the well. It is found that with these tanks little city water is required except for purposes for which the artesian water is not suitable. The well delivers about 100,000 gallons of water in the night, which is now saved and used. City water is sometimes needed, and it is admitted to the tanks by an automatic valve, which opens when the tank level reaches a certain point. The storage capacity is also useful in case of fire.

From the storage tanks pipes lead to the condenser in the machine shop engine room and also to the condenser in the planing mill engine room and return pipes deliver the hot water to the large brick reservoir, which is located partially underground and between the two elevated storage tanks. Any overflow from this reservoir is used to flush the sewer. The exhaust steam from the air and water pumps is also utilized to heat the water in the reservoir, the steam being first conducted through a feed water heater to obtain as much

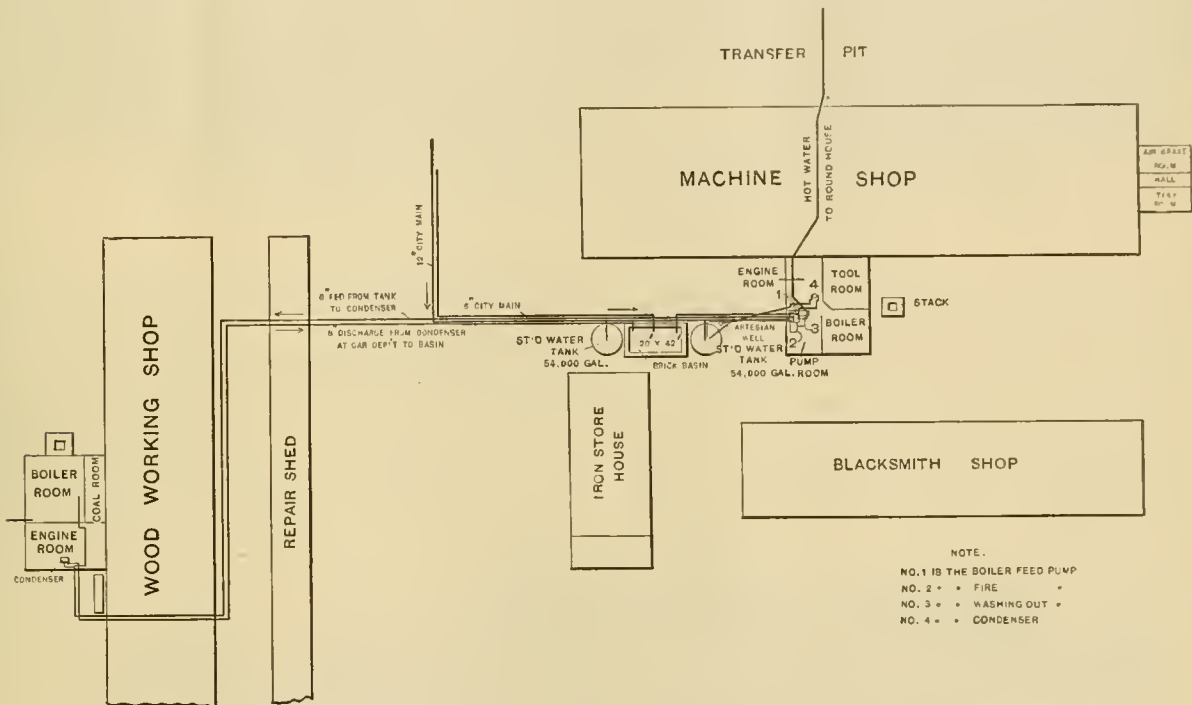

Condensers for Shop Engines—Chicago, Milwaukee & St. Paul Railway.

The essential features of this interesting condenser system are an artesian flowing well, two large storage tanks, a storage reservoir for the hot water, condensers in the machine shop and the planing mill engine rooms—about 300 feet apart—a pump for forcing the hot water into the piping system connected with 22 hydrants in the round house and the necessary piping for the circulation of the condensing water and for leading the discharge from the well into the tanks. The whole system is also connected with the city mains for use in case of any failure of the well, but the chief object of the plant is to supply the condensers and to do the boiler washing with the artesian water, which is not fit for boiler use, in order to save the cost of the city water.

The location of the various buildings may be seen from the accompanying diagram, and the arrangement of the tanks, and the piping system will be understood from the explanation which follows:

The well consists of 1,500 feet of 5-inch pipe; it does not flow sufficiently during the day time to furnish all of the water needed, hence the storage capacity in the form of two large 54,000-gallon tanks was found necessary, and in addition to this the reservoir, which holds 50,000 gallons more, assist in furnishing storage into which the well discharges during the

benefit from its heat as possible. For washing out locomotive boilers in the roundhouse warm water from the reservoir is forced by a special pump into a system of piping, which is cut off from the city mains by a valve, and in case of failure of the hot water system, cold water may be used direct from the mains.

Water for use in the foundry, blacksmith shops and wherever the artesian water may be used is taken from the elevated storage tanks, and a great saving in the use of city water is thereby made.

The question of shop heating is solved without interfering with the use of the condensers by utilizing the exhaust from the air and water pumps for this purpose, the exhaust steam being turned into the storage reservoir when the back pressure increases above two or three pounds. The water in the reservoir is warm at all times, and during the first week in January last it averaged about 110 degrees Fahr. In case the shops should require a great deal of steam for heating, it is of course possible to obtain it by sacrificing at the condensers, but this would be required very seldom, and probably but for a few days at a time. The system seems to be a very good one, and so far it has made it possible to save about 40 per cent. of the former cost of city water. It is reported

to have saved its entire cost of installation during the first year of its use.

The condensers are of the jet type, and were furnished by the E. P. Allis Company, of Milwaukee. They easily maintain a vacuum of about 23 inches, which is equivalent to an addition of the same amount of steam pressure in its effect upon the power of the engines, aside from the fact that the engines now consume less steam than before. It is obvious that in cases where hot water is not required for washing out boilers a cooling tower might be used, and this plan is deservedly growing in favor by those who are unable to obtain sufficient large quantities of water to use condensers without cooling the water. The plant at West Milwaukee was not an expensive one to install and it has much to commend it.

We acknowledge the courtesy of Mr. E. A. Manchester, Assistant Superintendent of Motive Power of the road, for the drawings.

RAILWAY CLUBS AT THE NILES TOOL WORKS.

The Western and Central Railway clubs were recently very pleasantly and instructively entertained by the Niles Tool Works at Hamilton, Ohio, excursions being arranged for the benefit of members of both of these organizations at different times. Judged only from a purely business point of view, this idea of inviting the men who purchase and use metal-working machinery is an excellent one. It enables them to see how the manufacturers work out problems which in many respects are similar to those which are constantly presenting themselves in railroad practice. Among the most instructive of the points so obtained are those pertaining to the working of tools in such a way as to secure the maximum output. The Niles Tool Works were exceedingly liberal in throwing their plant open so unreservedly, and it was undoubtedly appreciated by the guests.

Among the tools which specially attracted attention were a number built to meet special requirements to go to France, Germany, St. Petersburg and even to Johannesburg, South Africa, also a number of driving wheel lathes were in hand for Egyptian railroads, and an interesting example of American competition in England was in the form of a wheel lathe for Manchester, England. There were many other machines in hand which interested the visitors, and attention was also attracted to the foundry and the gun shop. The foundry has a main portion and two wings, and the heavy work is handled by eight electric traveling cranes, the capacity of the largest of which is 60,000 pounds. While the visitors were interested in the machine tools, it is doubtless true that they were even more interested in the work on the twelve-inch rifled mortars and the ten-inch guns and disappearing gun carriages. One of the latter, being set up complete in the machine shop, was exhibited and operated for the benefit of the visitors.

It is certainly a remarkably bold piece of engineering to mount a ten-inch, high-power gun on steel levers, which are long enough to elevate it above the wall or bank that shields it, and at the same time to make the machinery sufficiently strong to withstand the force and shock of the recoil in firing. The parts of these carriages are made with great accuracy, and the Niles Tool Works have been highly complimented on the work which they have done. In order to understand the nicety of the work it should be stated that the elevation of the gun is determined from tables, and it is given the correct elevation when in the lower position; then, when raised to its firing position the machinery must come to a stop at exactly the right point or the angle of elevation would be affected. We are informed that these guns come up to position with an accuracy that is hardly short of perfect. The guns which are being made by this concern are also of special interest, particularly when the exact allowances for the shrinkage of the various hoops and the accuracy required in boring and rifling the barrels are considered. The inspection by the Government officers is very rigid, and the fitting must be so accurate as to require keeping the temperature of the shop uniform which is done both day and night.

The development of these ten-inch guns has been very rapid and satisfactory, and the Niles Tool Works have been closely identified with it. It is worth noting that the rapidity of fir-

ing, which is a most important factor in ordnance, has been greatly improved by the work of this concern. Some time ago they guaranteed ten shots per hour (the best foreign record at the time) for ten-inch guns, mounted upon carriages of a different form from these, and the Government offered a premium of \$2,000 for every shot in excess of that number that could be made on the trial. The result was a reward of \$44,000 for 22 shots above the requirements. We are informed that this is better than has ever been done with guns of this caliber in Europe.

The present order calls for 14 ten-inch guns, eight of which have been completed. The works are very busy, and more men are now employed than at any previous time in the history of the company.

THE GOLD ELECTRIC HEATER—SOUTH SIDE ELEVATED, CHICAGO.

The South Side Elevated Railroad, of Chicago, commonly known as the "Alley L," is being rapidly equipped with the Sprague Electric Company's system of traction, and during the winter the railroad officials sought to determine the advisability of equipping their cars with electric heaters, and in order to satisfy themselves that the adoption of electric heaters would be to their advantage, and at the same time find out which heater of the many offered was the most suitable for the purpose, the road made some very careful and extensive tests of the heaters of five of the most prominent electric heating companies in this country. Each of these companies was given the privilege of equipping a car, and the five cars thus equipped were run during the winter.

The result was that the contract, amounting to about 3,000 heaters, was awarded to the Gold Car Heating Company, of New York and Chicago. The car which the Gold Company equipped was supplied with twenty-four of the improved "Gold Standard" electric heaters. The heaters were wired to permit of six graduations of temperature, which was controlled with a regulating switch. It is stated that its car was comfortably heated in the coldest weather, and that the regulation of the temperature to suit the outside conditions was entirely satisfactory. With the "Gold Standard" electric heaters a satisfactory uniformity of the temperature was maintained at all times in all parts of the car.

The heaters are placed under the seats, eight at each end and eight under the cross seats at the center of the car. The regulation is by a switch at each side of one end of the car, and the circuits are so arranged as to divide the heaters into four sections, whereby any required temperature may be easily obtained. The heaters are 3 inches in diameter and 20 inches long, and are made of steel spirals, upon which enamel is thoroughly baked at a very high temperature. Over this enameled spiral the heating coil is placed, and the ends of the coils and of the spirals are secured to porcelain end pieces, the whole heater being covered by a perforated iron casing. The spirals are non-conducting, and are not affected in any way by the current or the heat. The resistance coils are of a special non-corrosive composition, and in the heaters they are not under tension. A free circulation of air is provided about the coils, which is an exceedingly important item.

As this is one of the largest orders for electric heaters that has ever been placed, the Gold Car Heating Company have reason to be gratified with their success and its recognition.

LECTURES AT PURDUE UNIVERSITY.

Mr. L. R. Pomeroy, Sales Agent of the Forge Department, Cambria Iron Works, recently treated the senior students in mechanical engineering of Purdue University to an excellent description of the character and significance of the "Coffin Process," as employed by the Cambria Company. The lecture was illustrated by means of charts and diagrams, and was an interesting presentation of the process employed in producing axles, crank pins and similar forgings by that company.

This is in accordance with an excellent plan adopted at Purdue, and also at other colleges, whereby the students are brought into contact with engineers who are recognized as specialists in various lines of practical work. It provides means for broadening the view of students in a way that is impossible otherwise. Men like Mr. Pomeroy are able to give an insight into important subjects with which they are conversant in such a way as to give students an idea of the practical side of engineering work, and it is highly important that they should understand the difficulties of practical engineering and the ways in which they are met commercially. Such glimpses of the work with which they are to be concerned after the completion of courses at technical schools may be made most valuable, and the practice is to be commended and encouraged. This is a plan with which the friends of technical education are in hearty sympathy.

THE "PERFECT" PASSENGER CAR TRUCK.

Photographs of a three-spring "Perfect" truck and one of an eight wheel car for the Buffalo & Niagara Falls Electric Railway Company fitted with trucks of a similar design have been received from the builders, the J. G. Brill Company of Philadelphia. The car, which is suitable for city, suburban and

result is remarkable, and we are pleased to say that we know of no safer or better truck in the market."

In our issue of August, 1896, page 193, we gave several views, together with a description of the truck, and called attention to the special features, which may be summed up as follows: The spring base for this truck is unusually wide, steadying the car and reducing the rolling on the springs.

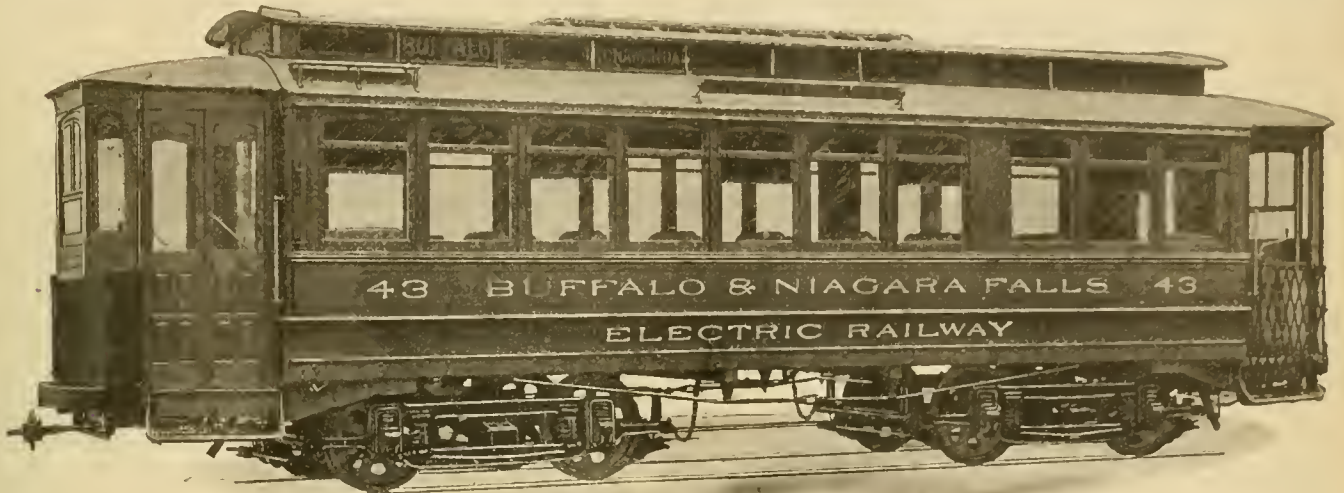

Brill Cars—Buffalo & Niagara Falls Electric Railway.

interurban service, is 29 feet long and weighs 14,500 pounds, the weight for each truck without motors being 5,100 pounds. It is in use under very severe conditions of service, combining those of the lines in city streets and also those of open country running between Buffalo and Niagara Falls. The peculiar conditions require trucks which, with wheels adapted to city street rails, shall be equally satisfactory under comparatively high speeds while running on T-rails.

The trucks of this car are known as No. 27, and it was

the equalizing bar is carried on springs and is supported by two sets; there are three sets of springs carrying the full load, and they are arranged in what would be termed "in series" in electric parlance. The load is equalized among the wheels and almost all of it is carried upon springs. It will be remembered that the side frames are forgings of the type long ago adopted for locomotive frames. For steam service they are forged, but for electric equipment they are made of cast steel. Our second illustration shows the ar-

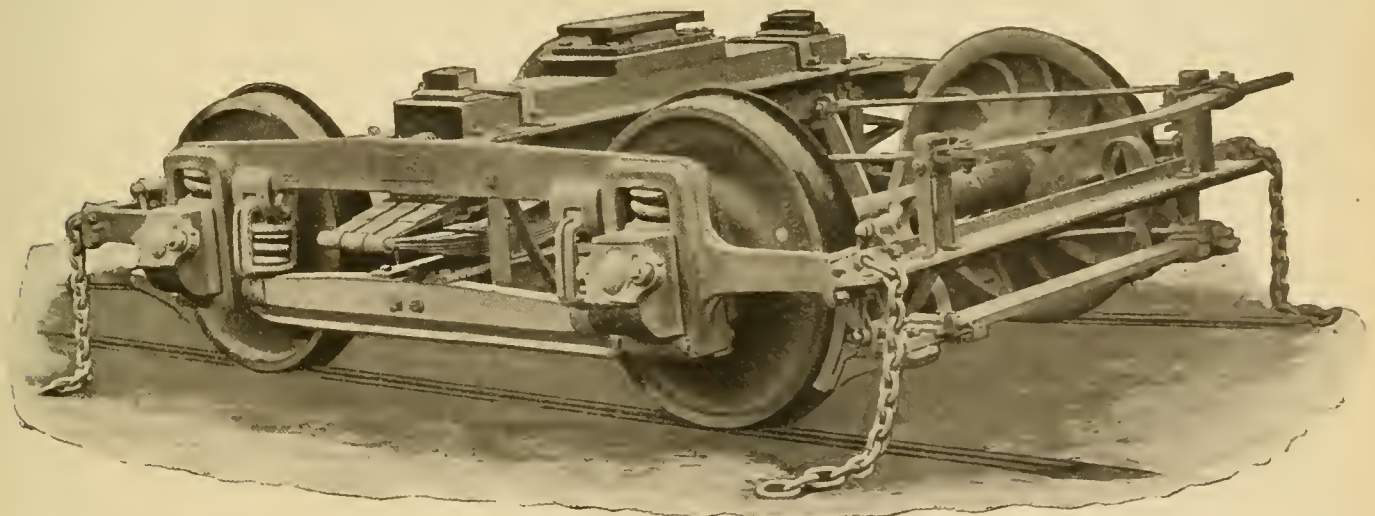

Brill Three-Spring Electric Truck, No. 27.

upon this road that the first tests of this type were made. In this connection it is interesting to note that in a circular recently issued by J. G. Brill Company a letter from Mr. Burt Van Horn, General Manager of the Buffalo & Niagara Falls Electric Railways, says: "We have a very hard combination of conditions to work against, operating, as we do, an interurban road, the width of the tread and depth of flange being governed by the city rails, and we have yet to record an instance of one of these trucks leaving the rails. In view of our experience with the ordinary center pivotal trucks, this

arrangement of a truck for heavy service, the wheel base of which is 6 feet and the weight of the truck is 7,790 pounds.

The circular already referred to contains a number of strong letters from railroad officers who are using the trucks, and it is noticeable that the easy riding qualities and the safety against derailment have impressed the authors of the letters. The trucks are used under 50 foot passenger car bodies, weighing 40,000 pounds, and it is stated that although 500 trucks are in operation on 20 railroads, not a single case of derailment has yet been reported. For the reasons for this "adherence" to the track readers are referred to our previous article on the subject.

(Established 1832.)

AMERICAN ENGINEER

CAR BUILDER AND RAILROAD JOURNAL.

29TH YEAR.

67TH YEAR.

PUBLISHED MONTHLY

BY

R. M. VAN ARSDALE,

MORSE BUILDING.....NEW YORK

G. M. BASFORD, Editor.

MARCH, 1898.

Subscription.—\$2.00 a year for the United States and Canada; \$2.50 a year to Foreign Countries embraced in the Universal Postal Union. Subscriptions for this paper will be received and copies kept for sale by the Post Office News Co., 217 Dearborn Street, Chicago, Ill.

EDITORIAL ANNOUNCEMENTS.

Advertisements.—Nothing will be inserted in this journal for pay, EXCEPT IN THE ADVERTISING PAGES. The reading pages will contain only such matter as we consider of interest to our readers.

Special Notice.—As the AMERICAN ENGINEER, CAR BUILDER AND RAILROAD JOURNAL is printed and ready for mailing on the last day of the month, correspondence, advertisements, etc., intended for insertion must be received not later than the 20th day of each month.

Contributions.—Articles relating to railway rolling stock construction and management and kindred topics, by those who are practically acquainted with these subjects, are specially desired. Also early notices of official changes, and additions of new equipment for the road or the shop, by purchase or construction.

To Subscribers.—The AMERICAN ENGINEER, CAR BUILDER AND RAILROAD JOURNAL is mailed regularly to every subscriber each month. Any subscriber who fails to receive his paper ought at once to notify the postmaster at the office of delivery, and in case the paper is not then obtained this office should be notified, so that the missing paper may be supplied. When a subscriber changes his address he ought to notify this office at once, so that the paper may be sent to the proper destination.

The paper may be obtained and subscriptions for it sent to the following agencies: Chicago, Post Office News Co., 217 Dearborn Street. London, Eng., Sampson Low, Marston & Co., Limited St. Dunstan's House, Fetter Lane, E. C.

We are gratified by the large number of new subscriptions for this journal which are coming in daily, and in spite of the fact that an unusually large edition of the January number and a still larger one for February were printed, we are obliged to apologize to our friends for not being able to supply the present demand for those two numbers. The February edition was the largest we ever printed, and it is now entirely exhausted. We print a much larger edition of the current issue in order to fill the orders for the first paper in the series on "The Construction of a Modern Locomotive" by "Motive Power," and, as the demand will be large, you are urged to subscribe immediately, in order to secure the complete series.

A suggestion with regard to the lubrication of locomotive driving journals is made in another column of this issue, and the importance of the subject renders it attractive to all who have had trouble—and who has not—with the heating of these journals. It will probably present a new idea to many of our readers with regard to the best methods of introducing oil to bearings, which applies to nearly all bearings, whether upon driving journals or not. Even in cases where no trouble by heating has occurred, this method of lubrication has much to recommend it.

The great struggle between the Amalgamated Society of Engineers and their employees, which has been going on in England and has been one of the greatest of industrial contests, has been brought to a close by the withdrawal of the demand for a 48-hour week on the part of the employees. It is estimated by "The Engineer" that this strike has caused a loss in wages of £2,400,000, and that the cash supplied by the unions has amounted to £900,000. Put in terms of our money, the expense has been \$12,000,000 to the employees, at the most conservative estimate. The employees did not have the support of public opinion in this tremendous struggle, and they were outlasted by the employers, who are now stronger than ever, while the unions are weaker.

The advantages of induced over forced draft in steam boiler practice find an analogy in efforts to increase the output of workshops by increasing the amount of work done by the employees. It is easier to induce than to drive men, and they may be drawn farther than they may be pushed, but it is not often that the fact is so well pointed out as it was by Mr. L. S. Randolph at the recent meeting of the American Society of Mechanical Engineers. In discussing the subject of the cost of shop operations he related his experience in raising the pay of one of the blacksmiths who had been making a certain forging of irregular and difficult shape. A certain number of them, say 100, cost \$6.25, and as an experiment the pay of the men was raised 20 cents a day, with the result of reducing the cost of making the same number to \$3.50. This is another example of the sort that may be expected to follow the introduction of piecework, when arranged upon a good plan, and it seems to be a very natural result of a little encouragement.

The advisability of informing locomotive enginemen as to the cost of the various items of supplies that they use was mentioned by Mr. E. T. Jeffery, President of the Denver & Rio Grande Railroad, in an address before the employees of that road. The idea presented was an important one, and it has a bearing upon many branches of the service besides that of the locomotives. It was remarked that enginemen were very careful of white lantern globes that cost only 8 2-3 cents each, and were very careless with red globes that cost 53 cents each. A proper realization of the relative importance of the various supplies handled by the men would doubtless have a good effect upon the returns, and by the great stress that is often laid upon the necessity of saving oil it appears to be possible to over-estimate the importance of some items to the neglect of others that have a much greater bearing upon the earnings. This naturally leads to the conclusion that it would be well to give the standing of the men as regards the use of supplies in terms of the cost of those supplies. This is not a new suggestion, but so far as we know it has not been carried out, except in the cases of wasteful men. It would seem to possess advantages for common use.

The Westinghouse High Speed Brake, which was illustrated and described in our issue of August, 1897, and which at that time had been in use on the New York Central "Empire State Express" trains for three years, has met with favor on other roads, which are running fast trains. Figures recently published show that a train having the ordinary brakes, running at nearly 58 miles per hour, required a space of 1,593 feet in which to stop, while another train, running at 60 miles an hour, and equipped with the high speed brake, required only 1,100 feet. It appears to be very important to make the best possible use of the additional braking power obtainable through the use of the additional pressure that this attachment provides at the first application of the shoes to the wheels and as a matter of 500 feet in the length of a stop generally decides the character and extent of a collision, it may be said that the high-speed feature cannot be put on too soon. It has been applied to the fast trains of the Pennsylvania running between Cleveland and Pittsburgh; on the "Con-

gressional Limited" of the Pennsylvania, between Jersey City and Washington; on the "Black Diamond" of the Lehigh Valley, and the "Empire State Express" of the New York Central. It will be remembered that this high speed brake provides a pressure of 110 pounds per square inch, instead of 70 pounds at the application of the brakes, and that by relief valves, the pressure reduces to the ordinary pressure, as the speed decreases, which prevents the sliding of wheels.

The value of condensers applied to stationary engines and the comparative ease with which the application may be made even when condensing water is expensive and scarce, is one of the lessons to be learned from recent electric power station practice. In view of the successful introduction of water cooling towers for cooling water that has passed through condensers, it is surprising that advantage should not more often be taken of this method of increasing the power of existing engines and of improving the efficiency of engines whether new or old. The cooling tower makes it possible for condensers to be used in localities far removed from abundant water supply and in view of the fact that from 15 to 25 per cent. of saving in fuel consumption may be effected by using condensers, it is evident that the subject is worth looking into, in connection with power stations and railroad shops. It is not always necessary to cool the condensing water, for often it may be found advisable to use it hot, as in the case of the Chicago, Milwaukee & St. Paul Railway plant at West Milwaukee, which is described elsewhere in this issue. The chief advantage possessed by this plan is that it may be applied without great expense, and we hope by the presentation of the simple and interesting water and condenser system at West Milwaukee, to show how easily the plan may be worked out and how valuable it is as a money saver. If the hot water is not used for washing out boilers, the problem is yet simpler, as Mr. Louis R. Alberger showed in his paper before the American Society of Mechanical Engineers—printed in volume XVII. of the transactions of that society, page 625. It is believed that this subject is worthy of a great deal more attention than it has received, and that it will be given a more important place in stationary steam engine plants in the future.

The great value of uniformity in naval construction has been urged in these columns, particular stress being laid upon the advantages to be had from duplication and interchangeability in the machinery. It is apparent that in case of accident to an important part of an engine annoying and even disastrous delay may be avoided by the possibility of using a duplicate part carried upon another ship of the same class. There is a much stronger argument for uniformity in design from the standpoint of those who fight the ships, which was admirably expressed by Mr. Charles H. Cramp in a recent lecture on "Mechanism of Modern Naval War" before the Naval War College and published in the "Journal of the United States Naval Institute." He suggested that it did not require the training of a naval tactician to see that a fleet of ten Indianas, compact, handy ships, alike in all leading qualities, would have the ten unequal and diverse battleships of the Mediterranean fleet of Great Britain at an initial disadvantage of tremendous effect, and this without taking advantage of individual superiority. Mr. Cramp believes these considerations to be conclusive against multiplication of types and he believes homogeneity of fleet organization to be of first importance in the use of ships. The effectiveness of a number of ships, all alike, even if they are weak individually, is much greater than that of the same number of ships of unequal ability, even though some of them should be considerably superior to those of the uniform fleet. The uniform fleet could act as a unit the power of which is the ability of one ship multiplied by the number of ships, whereas the fleet of ships of unequal power would be handicapped and limited by the ability of the poorest ship. While it may be true to a certain extent that adherence to applied designs interferes

with progress, it is also true that too hasty progress interferes with the best results and because of the experience of other nations in the direction of diversity in ships we ought to learn the importance of uniformity. Mr. Cramp believes that the first and most important lesson that will be taught by a fight between modern battleships will be the advantage of similarity of type and equality of performance in the ships in action. There seems to be a great deal to support this opinion and nothing to refute it.

LUBRICATION OF DRIVING JOURNALS.

The increasing weight of locomotives introduces many difficulties which will require attention, in order to avoid vexatious troubles on the road. Among these is the heating of the driving journals, which has already given notice that it is to be heard from. The lubrication of locomotives is generally recognized as important, but it is also considered as one of the minor details of operation, and is generally expected to take care of itself. The bearings in locomotive running gear work at all times under the disadvantage of being in an atmosphere of dust and grit until it is surprising that they do not heat much oftener than they do. It is believed however, that the time has come to give more thought to lubrication.

It is not enough to carry oil to a bearing, it must be carried to and between the bearing surfaces, in such a way as to

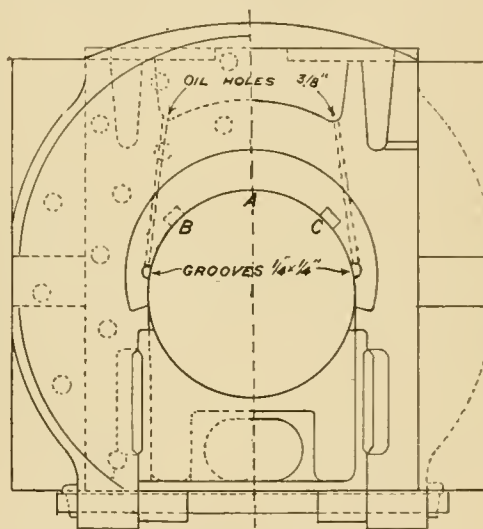

be sure of staying there. Good lubrication depends upon introducing the lubricant properly and upon the design of the bearing, with such proportions as to avoid squeezing the oil out from between the surfaces. It has been known for years that bearings should not be lubricated upon the side where the pressure or the loading is applied, or rather that when the lubricant enters the bearing on the pressure side the loading cannot be nearly as great as when the lubricant is applied elsewhere, and yet the most common method of oiling a driving journal is at the top of the bearing. In the days of light locomotives and lightly loaded trains the longitudinal oil pocket in the crown of the box, into which the oil was fed from the top of the box, which was packed with waste to hold the oil, was entirely satisfactory, and as long as the journal pressures and piston thrusts were moderate this plan worked very well, but much trouble has followed the continuance of this method of oiling under the changed conditions of work and loading and it seems to be sure to give, to say the least, no less trouble in the future. This leads to the question: Where is the best place for the introduction of the oil into the bearing of a locomotive driving journal?

While others have worked upon the problem of lubrication

of bearings, the experiments of Tower and of Dewrance (for the latter see "Engineering," Vol. LXIII., page 29) should be credited with bringing the subject before engineers in a practical way. Dewrance showed experimentally that the lubricant in a bearing loaded at its top exerted a pressure through a hole in the top of the bearing. He attached a pressure gauge to the hole and found a pressure of oil corresponding to the load put upon the bearing. He further found that when the hole was put beyond the center of the shaft the air in the hole adhered to the shaft and was carried round, leaving a vacuum, and proved this by the gauge. Under favorable conditions he found this vacuum to amount to 30 inches, which was within one-quarter inch of the barometer at the time. He drew this conclusion from his experiments: "That bearing surfaces that are properly lubricated are separated by a film of oil at a pressure per square inch equal to the load that is upon them." The realization of this fact suggested to him the following rule, which may be applied to nearly all classes of bearings:

"Introduce the oil at the points of least pressure, and do not provide a means for escape for it at the points of greatest pressure."

Mr. Dewrance further says: "It is very easy to find out these points of an ordinary bearing that are least subject to pressure, and the oil can generally be brought there with a little scheming. The means of escape most generally met with are oil holes and channels that frequently occur just at the crown of the bearing where the pressure is greatest. When the pressure on such a bearing is intermittent, the oil goes in when the pressure is taken off, and escapes out again when the pressure comes on, the effect being that the bearing is only able to support a proportion of the load that it could support if lubricated according to the rule."

The correctness of the rule has been proved in marine practice, as regards main propeller shaft bearings, thrust bearings and those of connecting and piston rods. Working in this direction, whether with the rule in mind or not, does not matter, a motive power officer of high standing has apparently solved the problem of hot driving journals. He found trouble in the use of the cavity in the crown of the box fed through a hole from the top and first tried two cavities in the box located 45 degrees on either side of the vertical center line of the bearing, and he also cut two diagonal grooves between these two cavities. This was not a success, it gave a little relief, but did not cure the heating of the journals. The question of pressures on the bearing was then investigated, and by means of a polar diagram it was shown that when the engine was running at speed there was practically no difference in the radial pressures at the crown of the box and at a point 45 degrees away from it, and that the pressure gradually diminished down to the horizontal center line of the axle. This led to the removal of the cavities in the crown and at the 45 degree points and two narrow and shallow horizontal grooves were cut across the box slightly above the horizontal center line. These grooves were milled into the shell and three-eighth-inch holes were drilled down into the grooves from the oil cavity in the top of the box and the oil fed directly to the grooves. The drawing shows what was done. First the cavity was at "A," the crown of the box, then cavities were cut at "B" and "C" and finally the grooves and oil holes were tried, as shown, and the trouble from heating was overcome. It was also found that these grooves did not wear smaller as the greatest wear came between "B" and "C."

This plan was tried on one of the journals of an engine that had given a great deal of trouble from hot bearings and after a single run as a helper up a heavy grade the engine was sent out on a through train with no trouble from the box. A second bearing in the same engine was afterward replaced in the same way and this time no trouble was taken to break the box in on a slow run, the engine being returned to its through run immediately.

The plan seems to be a success practically, which is satisfactorily accounted for by the experiments of Dewrance. The

proper lubrication of a bearing is worth while; it saves repairs and reduces friction; it saves wear, as was shown by Mr. Alfred Moreum, in his paper, before the Institution of Mechanical Engineers, at Birmingham (England), in which he told of a 300-horse power two-cylinder compound stationary engine, that had been working continuously for four years, at 10.5 hours per day, and when taken down for adjustment, it was found to be absolutely unworn, as far as the bearings were concerned. This engine worked under a system of forced lubrication. In a discussion of this paper, it was stated that by reason of employing this system of forced lubrication engines were often run an entire year, stopping only once for cleaning. These are mentioned with the purpose of calling attention to the advances which have been made and their practical value in connection with high speed stationary engines. B.

NOTES.

The subject of the adoption of nickel steel for marine boilers has attracted a good deal of attention during the past twelve months. Messrs. W. Beardmore & Co., Glasgow, says the "Mechanical World," have just completed the plates for the first boiler in that metal, to be fitted on board a vessel now building on the Clyde. They are also executing at present several orders for propeller shafts for yachts in that alloy, the greatly increased strength and superior qualities of nickel steel specially commending it for that purpose.

It has been practically decided that the immense electric beacon, built by Henri Lepaut, of Paris, and exhibited at the World's Fair and at Atlanta and Nashville, is to be erected at Navesink Highlands, near Sandy Hook, on the coast of New Jersey. It has been undergoing an elaborate series of tests at the headquarters of the Third Lighthouse District, at Tompkinsville, Staten Island. The theoretical range of this light is 146.9 nautical miles and its candle power is given as ninety million. It has two lenses each nine feet in diameter.

In the mercantile marine, it is beyond question, says "The Engineer," that pressures are rising. The limit has been for the time attained by the Inchmuna, whose five-cylinder engines work with 250 pounds of steam. A good deal of criticism has been expended on Mr. Mudd's engines, but they have accomplished all that he promised; at all events, that is the opinion of the owners, who have recently handed over to the directors of the Central Engine Works, West Hartlepool, the large balance which was held over conditionally until a year's working had proved that the engine would satisfy the guarantee. The owners have paid on the basis of a consumption of only 1.15 pound of coal per horse power per hour—an economy which has not, we believe, ever before been attained at sea over twelve months.

In "Scotch" boiler engineering some remarkable advances have been made, says "The Engineer," in reviewing the progress made in marine engineering in the year 1897. A few weeks since Mr. Mudd did a new thing. He has made Scotch boilers ten feet long, and of large diameter, with the shell made of two plates only, flanged at the ends, and riveted to flat end plates. There are two longitudinal straps the whole length of the boiler. After these plates have been bent and flanged, they are placed in a great annealing furnace to do away with local strain. There are no rivets at all under the boiler. Very heavy plant and very big plates are needed, but the boiler thus made is a magnificent piece of work.

That block signals do not necessarily retard traffic and that when carefully arranged and well installed they expedite it, was shown by Mr. Henry Miller, assistant superintendent, St. Louis, Keokuk & Northwestern Railway before the St. Louis Railway Club, when he said that "enginemen can run at speed with safety, relying upon the indication of the signals as against the uncertainty and fear of running into some unprotected

train. We have found that, instead of retarding the movement of traffic, it very materially expedites it. During last December, when our business was very heavy and train movements averaged 100 a day, there was but a single failure."

A strong indorsement of manual block signals was recently offered by Mr. H. D. Judson, before the St. Louis Railway Club, when he said: "The Burlington road about eight years ago, after a very troublesome and costly experience with a heavy traffic, installed on its line for 37 miles west of Chicago the manual block. It consists simply of semaphore blades placed on masts, an average of two miles apart, and operated by a man in a tower. We move over this portion of the road as high as 225 trains a day, or an average of at least 150 a day the year round. The movement of 150 trains means 300 signal movements at each block, 5,700 signal movements every day, or 2,080,500 signal movements a year. Since the installation of the block we have never had an accident for which the block could be held responsible, or one which any block at present in use would have averted. Delays are very infrequent, and if a train ever, during all that time, made a wrong movement, caused by a wrong signal movement, the fact has not come to my knowledge. We do not claim that it is a perfect signal, but we feel pleased with the record we have made with it. Over 2,000,000 signal movements a year intrusted to human hands, without a serious mistake, speaks volumes for the faithful manner in which it has been operated by the signalmen and observed by the enginemen. During the eight years we have used this block we have moved a grand total of considerably over half a million trains. The operation of the block has cost us, approximately, \$75,000, or about 14 cents a train, so that we have insured the safe passage of trains over a congested portion of the road for less than one-half a cent a mile.

The report of the Commissioner of Patents states that in 1896 there were received 42,077 applications for patents, 1,828 applications for designs, 77 applications for re-issues, 2,271 caveats, 2,005 applications for registration of trade-marks, 59 applications for registration of labels, and 36 applications for prints. There were 23,312 patents granted, including designs, 61 patents reissued, 1,813 trade-marks registered, and 1 label and 32 prints. The number of patents which expired was 12,133. In proportion to population more patents were issued to citizens of Connecticut than to those of any other State, one to every 759 inhabitants; and next in order in proportion to population come the District of Columbia, with one to every 1,123; Massachusetts with one to every 1,177; Rhode Island with one to every 1,333; New Jersey with one to every 1,453; New York with one to every 1,545; Colorado with one to every 1,761, and Illinois with one to every 1,874. The States to whose citizens the fewest patents were granted in proportion to the number of inhabitants are South Carolina, one to every 31,976; Mississippi, one to every 27,438; North Carolina, one to every 23,793; Georgia, one to every 14,354; Alabama, one to every 13,880, and Arkansas, one to every 13,430.

The comparative output of six passenger car paint shops on one railroad was stated recently in the "Railroad Car Journal" to show that the greatest output per man occurred in the smallest shops, the explanation being that the oversight in the shops employing more men was deficient. This fact is significant as showing the care in management required to run a large plant successfully, and incidentally it furnishes an argument for piecework.

Locomotive tenders of the American or two truck type were used for the first time in Great Britain by Mr. J. F. McIntosh, Locomotive Superintendent of the Caledonian Railway in the design for 15 new engines, the first of which has just been completed. The engines are to haul main line express trains and the tender capacity is four tons of coal and 4,000 gallons of water.

A great bridge is reported to be projected across the Straits of Shimonoseki in Japan, with the object of uniting the main line of the Klushu Railway with that of the Sanyo Railway from Shimonoseki to Illogo. The straits, at the point referred to, are about one mile in width, and the current through them is very rapid. The bridge, moreover, must be constructed sufficiently high to enable the largest ocean steamers to pass beneath. Thus the undertaking, if successfully carried out, would be one of the greatest engineering feats of its kind. The work will be undertaken and supervised by Japanese engineers exclusively.

A speed of 73 miles per hour is recorded for a locomotive on the Pittsburgh, Cincinnati, Chicago & St. Louis Railway in a recent run with eight heavy cars between Columbus, Ohio, and Xenia, in the same State, a distance of 55 miles, which was covered in 47 minutes. The actual time of the run was 56 minutes, but this included three stops, one crossing slow-down and a delay of four minutes at London, making a total loss of nine minutes. The locomotive was built by the Schenectady Locomotive Works.

A new device for getting rid of snow has been tried by the Boston & Maine, for use at the Union station in Boston and in the yards adjoining. The car rests upon four ordinary wheels, but sets very low. It looks like a long box open at the top and with vent holes in the bottom. Through the center of the interior runs a long pipe with diverging arms and at frequent intervals through its entire length and that of the arms are small holes. When this car is attached to a shifting locomotive the pipe is connected by means of a flexible hose with a live steam coil in the engine. The snow is shoveled into the box and quickly melted, the water running out through the vent holes and down between the ties of the bridge into the river. It is calculated that this car can care for snow faster than 25 men can shovel it.

Bilge keels are finding considerable favor for use upon the transatlantic steamers of several lines, and they are being fitted to old as well as new steamers. The advantages claimed are that they prevent excessive rolling without decreasing the speed of the ships.

A large steel floating dry dock, costing \$1,500,000, to be built by a private corporation, is proposed to the House Naval Committee. The dock would be large enough for the heaviest battleships. In return for its use for 100 days of each year the Government is asked to guarantee six per cent. on the investment for 20 years, and in case of war the Government would have the exclusive use of the dock. The plans call for a dock 500 feet long, with a capacity of 15,000 tons, and it is suggested that it be moored near Brooklyn, N. Y.

The armor plate problem seems likely to be solved on a basis of \$400 per ton, as the price to be paid for that required on the new battleships Illinois, Wisconsin and Alabama. This price was reported favorably by the Secretary of the Navy last year, and it has just been recommended by a vote of the Senate Naval Committee. The plan of building a government plant does not appear to be likely to proceed further than its present situation—that is, on paper.

The anti-scalping bills have been reported favorably by both committees of Congress. The Senate reported favorably by a vote of seven to three and the House by a vote of fifteen to two. This may be taken as a promising situation and unless some very unexpected difficulty arises the abominable practices of scalpers will be squelched. The evidences of fraud, which have been brought to light chiefly through the energy of Mr. George H. Daniels, general passenger agent of the New York Central, are astonishing and it has been proved that scalping is one of the worst forms of dishonesty with which the railroads have to contend. This movement should

have the support of the people and members of the Senate and House should be reminded of their duty in connection with it. This may not be necessary, but it is a safeguard that costs so little trouble that it ought to be taken.

Some historic iron wire, taken from the Niagara suspension bridge, is described by Mr. Frederick W. Cohen, of the Pennsylvania Steel Company, in the "Engineering Record." This wire was manufactured in Manchester, England, and put into the bridge in 1855 by John A. Roebling. At that time the wires showed an average strength of 1,648 pounds each. On the removal of the cables in 1897 the wires were tested, showing an ultimate of 1,566 pounds per wire, equivalent to 93,960 pounds per square inch, which is 95 per cent. of the original strength. It would appear from these tests that iron wire, when strained well within the ultimate, does not deteriorate with use or age, the possible variations of the testing machine and the personal equations of the men making the tests being enough to account for the difference.

Prizes for working locomotives to their full capacity are offered to the enginemen and firemen of the Central of New Jersey. The men are offered a premium each month for the largest number of tons hauled in freight trains between Mauch Chunk and Jersey City, 115 miles. Each locomotive is rated at a certain number of tons, but enough margin is allowed to permit enginemen to exercise judgment and skill and thereby increase the loads hauled to a degree better than may be absolutely required of them. The prizes are \$125 for the crew hauling the greatest loads, \$50 to the second best and \$25 to the third. The engineman's portion is 60 per cent., the fireman's 40 per cent. and the premiums apply to those who make not less than eight round trips.

The Massachusetts Institute of Technology is to have a new building with five stories and basement, covering 58 by 161 feet. The basement and first floor are to be used chiefly by the mechanical engineering and architectural departments, the second floor by the biological department, the third, fourth and part of the fifth floors by architecture, and the rest of the fifth floor by industrial chemistry. The apparatus in the basement will include a 60-foot canal, 3 feet wide and 4 feet deep, for weir experiments, a 225 horse-power tandem compound engine, a 10-ton ammonia refrigerating plant, and a 150 horse-power Parson's steam turbine and dynamo.

RAPID TRANSIT IN NEW YORK.

Among the suggestions for improving the rapid transit facilities in New York, it is proposed to build a line from a point near the present downtown terminus along West street, to serve the North River ferries, which will connect again with the Sixth and Ninth avenue lines at a point above those ferries. It is also proposed that a line should be carried across the city from the Brooklyn bridge to connect with the Sixth and Ninth avenue lines and with the West street line referred to. Additional tracks on the existing structures are also proposed, for the purpose of handling a large portion of traffic over comparatively long distances, by means of frequent express trains, which could be run on third tracks, using them for downtown travel in rush hours of the morning and for uptown travel in those of the early evening. Another proposition has been offered for the extension of the present lines to the city limits on the east and west sides. The change to electric traction, which has caused considerable discussion, has not been made prominent in the most recent propositions by the Manhattan Company, and it is considered doubtful whether such an expensive change will be made in the immediate future. Such a change would provide means for greatly improving the acceleration of trains, and it would avoid disagreeable features of the present system. One of the most necessary improvements, a change in the lower terminals, has not been discussed as fully as many would like. We believe that it is here that the greatest improvement in handling the enor-

mous traffic can be made. The advantages that would be offered by a loop at the Battery seem to be very great and the saving of delays in switching which could be made would doubtless affect the capacity of all of the lines using that terminus.

EXHIBITS AT THE JUNE CONVENTIONS, 1898.

A circular has just been received from the Standing Committee of Railway Supply Men having in charge the arrangements for exhibits at Saratoga, from which we reprint the following:

"It is the desire of the officers of both the Master Car Builders' and the Master Mechanics' associations that the exhibits of supply houses should be as complete and instructive as possible, and to that end the Standing Committee is making every endeavor to arrange for satisfactory exhibits. The rear verandas and the court at Congress Hall have been placed at the disposal of the committee to be allotted to exhibitors without charge.

"The committee has arranged with the management of Congress Hall to furnish steam from a 65 horse-power boiler, a part of the plant of the hotel. A main pipe will be run overhead through the middle of the court, and connections may be made by exhibitors at convenient locations. Exhibitors desiring power will have to furnish the necessary connections from the main steam pipe and also such engines or motors as may be required.

"The heavy exhibits will be located on the lower veranda (ground floor) and in the open court. In making application for space, exhibitors will confer a favor by stating the nature of their exhibits and whether they desire space under cover or in the open court.

"The committee has received a proposition from Carpenter & Taylor, of Saratoga Springs, for cartage to and from the exhibit grounds at the following rates:

"Single boxes weighing up to 1,000 pounds, 25 cents each way.

"Three to five boxes, not exceeding 2,000 pounds, 50 cents each way.

"For heavy machinery, the cost of cartage may be arranged for by special contract.

"In shipping exhibits, it will be best for the exhibitor to consign the same to himself, care of Congress Hall, Saratoga Springs, N. Y., and if the exhibitor finds it impossible to be on the ground to arrange personally for the transfer from the railway station to the exhibit grounds, a letter of instruction to the secretary of the Standing Committee, care of Congress Hall, Saratoga Springs, N. Y., will serve to have the necessary cartage done, but no unpacking or installation of exhibits will be undertaken by the committee or any of its representatives.

"It is the hope of the committee that the installation of all exhibits will be completed by the evening of Tuesday, June 14th, so that the exhibitors may have the benefit of the full period of the conventions, and that there may be as little noise and confusion as possible on the first day of the Master Car Builders' meeting.

"Applications for space and other information should be addressed to Mr. Hugh M. Wilson, 1660 Monadnock Block, Chicago."

BUSINESS PROBLEMS OF THE MOTIVE POWER DEPARTMENT.

In an exceedingly interesting address delivered by Mr. Robert Quayle, Superintendent of Motive Power of the Chicago & Northwestern Railway, before the engineering students of Purdue University, on January 26 last, a number of important features of motive power work were treated, among which was one on the locomotive considered "as a machine—a tool for a purpose—representing a large investment of capital and costing annually a considerable sum for its operation." The speaker said:

Perhaps I can best illustrate this business problem by a comparison which every motive power official has had to make at some time, in connection with the rating of his engines. The tests that have been made upon the locomotive in the testing laboratory of this university demonstrate that the most economical point of cut-off is between one-quarter and one-third of the stroke. Other tests made on this same plant show that as the locomotive boiler is forced and the rate of combus-

tion increased, the rate of evaporation falls off rapidly. The conclusion is therefore warranted that with a given speed a cut-off later than one-third of the stroke will result in a loss of economy, both in the boiler and the cylinders. Are we, therefore, warranted in endeavoring to operate our locomotives under these conditions of maximum fuel economy? The work of the engine varies so much with the grades that we cannot expect to run at a uniform rate of cut-off, but is it economy to endeavor to give the locomotive such a load that it will average one-quarter to one-third cut-off? Let us look into the question. Suppose ours is a nineteen-inch engine in freight service on a hilly division, and that under a limitation of the average cut-off to one-third, the tonnage which it can haul over the division is six hundred tons, exclusive of its own weight and that of the way car. Let us further assume that if the engine is worked to its utmost capacity on the ruling grades (even if by so doing we must run it for many miles at from one-half to full stroke), we will be able to haul seven hundred and fifty tons. The train and engine crews' wages will amount to about 13.2 cents per mile, or \$13.20 per one hundred miles. When hauling the heavier train we are getting 25 per cent. more tonnage over the division for the same cost in wages, and thereby effecting a saving of \$3.30 for each hundred miles the seven hundred and fifty tons are hauled. This is a clear gain in operating expenses. Now, let us look at the actual consumption of fuel, and in doing this we must bear in mind that while our nominal weights of trains are six hundred and seven hundred and fifty tons respectively, the real weights (allowing one hundred tons for the engine and tender and fifteen tons for the way car) are seven hundred and fifteen and eight hundred and sixty-five tons, respectively. Evidently the weights of the engine, tender and way car form a fixed quantity in our calculations, and that the heavier the train the less the percentage of the total work of the engine needed to overcome their resistance, and the internal resistance of the engine. Evidently the coal consumption in our comparison should be figured on the basis of the tonnage of the cars and their contents only, for upon this is based the earnings of the train. For the six-hundred-ton train the coal consumption may be taken at, say, seventeen pounds of coal per hundred ton miles, or ten thousand two hundred pounds to haul the train one hundred miles. For the seven-hundred-and-fifty-ton train the consumption per hundred ton miles will be about $1\frac{1}{2}$ pounds less, or, say, 15.5 pounds per hundred ton miles. In other words, the lesser percentage of the total work of the engine expended upon itself, its tender and the way car, more than offsets the increased consumption of coal per indicated horse power. The total consumption for the seven hundred and fifty tons hauled one hundred miles will be about eleven thousand six hundred and twenty-five pounds. Thus, while the total consumption of coal per trip is, of course, greater for the heavier train, the consumption per hundred ton miles is less; consequently, the fuel bill to haul three thousand tons of cars and contents will be less if it is taken over the road in four trains of seven hundred and fifty tons, instead of five trains of six hundred tons. So we have saved money in both wages and fuel per hundred ton miles. But the question is broader still. Evidently fewer engines resulting in a lesser investment are required; furthermore, while the cost of repairs per mile run by the engine may be greater the cost per hundred ton miles of train hauled will be less; again, the fewer engines will mean a smaller investment in roundhouses, shops, machinery, etc., and last, but not least, the operating expenses will be reduced in more ways than train crew wages, and the liability of accident will be lessened by the fewer number of trains. Thus the broader the light in which this question is viewed the greater the economy of working the locomotive beyond the point of maximum economy per indicated horse power.

That this view of this business problem is correct will be acceded to by every motive power official. The situation may appear to you to be paradoxical, particularly in regard to the item of fuel, but that coal can be saved by loading an engine heavily we have proof of daily. The road with which the writer is connected keeps an individual coal record by which the consumption of coal per hundred ton miles by each engineer is recorded. In a group of men in comparable freight service on one division the best performance in November last was 15.9 pounds per hundred ton miles, the engineer having an average train of 853 tons. The poorest record was 28.7 pounds, but the average train was only 378 tons. Of course there are differences in engines (which was true in this case), but all our coal accounts support the statement that other things being equal the heavier the train the less the consumption per hundred ton miles. The limit to this rule is not reached before the engine is so overloaded that the required time cannot be made; so evident is this to our engineers that they are anxious to haul the heaviest trains of which their engines are capable, as by this means only will their records compare favorably with others in the same class of work.

This same mode of reasoning, by which the work of the engine is viewed by its effect upon the net cost of hauling tonnage rather than its economy in fuel per horse power, must apply to other questions involved in locomotive construction and operation. On this basis the size of locomotives has been constantly increasing and will continue to increase. Anything which adds to the economy of performance but limits the amount of work that can be obtained from the engine, either by reducing the tonnage it can haul per trip or reducing the mileage it can make per year, cannot hope to succeed. If a complicated valve gear would save five or ten per cent. in fuel, but would cause the engine to miss a trip occasionally because of repairs necessary to the mechanism, the loss of the service of the engine to the company in busy seasons would possibly more

than offset the saving in fuel. On the other hand, simple, strong and reliable construction of the locomotives, facilities for quickly repairing them, and everything that will add to its useful mileage per year, is worthy of careful study. At the same time the necessity of meeting these conditions does not relieve the motive power official of getting the greatest possible economy out of the locomotive as an engine, after he has met the conditions noted, and if he does his whole duty he will be eager enough, in his attempt to obtain this economy, to satisfy the most enthusiastic student of the steam engine.

Personals

Mr. Frank B. Drake, General Manager, Cincinnati Northern, has resigned.

Mr. J. A. Edwards has been appointed Master Mechanic of the Rio Grande Southern at Ridgway, Colo.

Mr. E. D. Codman has been elected President of the Fitchburg Railroad. He was formerly Vice-President.

Mr. E. Z. Hermensader has been appointed Assistant Master Mechanic of the Wheeling & Lake Erie, at Norwalk, Ohio.

Mr. T. H. Curtis has been appointed General Manager of the Astoria & Columbia River, with headquarters at Astoria, Ore.

Mr. Harry Conrod has been appointed Assistant Master Mechanic of the Columbus, Hocking Valley & Toledo, at Columbus, Ohio.

Mr. C. G. Vaughn has been appointed Chief Engineer of the New Orleans & Northwestern, with headquarters at Natchez, Miss.

Dr. Louis Duncan, of Baltimore, has been appointed Electrical Engineer of the Third Avenue Railway Company, of New York.

Mr. James Hickey has been appointed Master Mechanic of the Gulf & Interstate Railway, with headquarters at Beaumont, Tex.

Mr. James A. Corey, a locomotive engineer, on the Boston & Maine, has been appointed Master Mechanic of the shops at Portsmouth, N. H.

Mr. James M. Kirk has been appointed Master Mechanic of the Salt Lake & Ogden, with headquarters at Salt Lake City, vice W. T. Godfrey, resigned.

Mr. George Dickson, General Foreman of the St. Paul shops of the Great Northern, has been put in charge of the mechanical department at West Superior.

Mr. George H. Pegram, Chief Engineer of the Union Pacific, has resigned, to accept the position of Consulting Engineer of the Manhattan Elevated of New York.

Mr. A. C. Michaelis has resigned his position as General Manager of the Central Railway of Guatemala, Central America, owing to the revolution in that country.

Mr. W. McLane, late of the Plant System, has accepted the position of Master Mechanic of the Bellingham Bay & British Columbia Railroad, with headquarters at New Whatcom, Wash.

Mr. Edward L. Moser has accepted a position in the engineering department of the Baldwin Locomotive Works; he was formerly Mechanical Engineer of the Philadelphia & Reading.

Mr. C. C. Martin, long known as Chief Engineer and Superintendent of the New York & Brooklyn Bridge, has been ap-

pointed Engineer of Bridges for the Boroughs of Brooklyn and Queens.

Mr. James M. Kirk, formerly with the Chicago, Rock Island & Pacific, has been appointed Master Mechanic of the Salt Lake & Ogden, with headquarters at Salt Lake City, Utah, to succeed Mr. W. T. Godfrey, resigned.

Mr. J. M. Percy, formerly Master Mechanic of the Cincinnati, Hamilton & Dayton, at Cincinnati, Ohio, has been appointed Master Mechanic of the Baltimore & Ohio Southwestern, with headquarters at East St. Louis, Ill.

Charles B. Chester, Master Mechanic of the Guatemala Central Railway, of Central America, died at Chattanooga, Tenn., January 8, at the age of 47 years. He was formerly Master Mechanic of the Chattanooga, Rome & Columbus.

Mr. James M. Percy, formerly Master Mechanic of the Cincinnati, Hamilton & Dayton, at Cincinnati, has been appointed Master Mechanic of the St. Louis division of the Baltimore & Ohio Southwestern, with headquarters at East St. Louis.

Mr. A. D. Allibone has resigned as Purchasing Agent of the Wisconsin Central to take effect February 19, and will be succeeded by Mr. John A. Whaling, who held the position previous to January 1, 1896. Headquarters, Milwaukee, Wis.

According to a communication received from Mr. Robert Andrews, vice-president of the Safety Car Heating and Lighting Company, Mr. W. H. Hooper has been appointed general agent of the company, with office in Chicago, vice Mr. George N. Terry, resigned.

Mr. H. H. Vaughan, formerly Mechanical Engineer of the Great Northern, at St. Paul, has been appointed Mechanical Engineer of the Philadelphia & Reading, at Reading, Pa. Mr. Vaughan is a capable young man, with a good record. He and the officers of the road are to be congratulated.

Mr. J. F. Weed, a Civil Engineer, of Houston, Tex., was appointed February 6, Chief Engineer of the Gulf, Beaumont & Kansas City Railroad, with headquarters at Beaumont, Tex. Mr. Weed was formerly connected with the Land Department of the Southern Pacific and the Houston & Texas Central.

Mr. Samuel Porcher, heretofore Assistant Purchasing Agent of the Pennsylvania Railroad, has been appointed Purchasing Agent to succeed A. W. Sumner, deceased. Mr. Porcher has been in the service of the Pennsylvania since 1882, and has been Assistant Purchasing Agent since 1894. His office is at Philadelphia.

Mr. A. D. Wilder, Division Superintendent of the Southern Pacific, died at Oakland, Cal., February 14, of pneumonia. He was born in Attica, N. Y., July 31, 1843, and entered railway service in May, 1859, as clerk, with the Erie, and had been with the Central and Southern Pacific roads since December, 1868. He was appointed Division Superintendent in December, 1878.

Mr. H. E. Walker has been appointed Locomotive and Car Superintendent of the Inter-oceanic Railway of Mexico, succeeding Mr. E. V. Sedgwick, resigned. Mr. Walker has been Superintendent of Machinery of the Mexican Southern Railway for nearly seven years, coming from London when the road was commenced. His place will for the present be filled by Master Mechanic W. I. McCammon.

As we go to press reports have been received to the effect that the Brooklyn Elevated Railroad has contracted with the Walker Company, of Cleveland, to equip 150 cars with Walker electric motors, which are to be controlled by the Sprague system of multiple control. This system was adopted with a view of running the cars over the Brooklyn Bridge into New York, and this system of control disposes of the difficult problem of switching the cars at the New York terminal. The work is expected to be completed by June first.

BOOKS AND PAMPHLETS.

"Whittaker's Mechanical Engineer's Pocket-Book." By Philip R. Bjorling. Size, 4 by 6 inches, 377 pages; bound in leather. Illustrated. Published by The Macmillan Company, 66 Fifth avenue, New York. 1898. Price, \$1.75.

This book contains 130 tables, in which pumps and hydraulic work are specially well represented; pipes, windmills, gas engines, steam engines, mining machinery, ropes and belting, speeds of machinery and tools wire gauges bolts and nuts, weights of plates and mathematical tables are also included. The book contains much information that is needed by steam engineers and machinery designers, and much more that is valuable in hydraulic work. It is provided with an index and is convenient in size.

"The Monthly Official Railway List," January, 1898. "The Official Railway List," which for 26 years has appeared as an annual publication, and is probably the best known list of railroad officials published in this country, has just added to its usefulness by appearing each month. The first copy under the new plan was received too late to be mentioned in these columns in our February issue. The list includes an alphabetical list of all railroads in operation in the United States, Canada and Mexico, with a list of officers and their addresses, fast freight lines and private car lines and their officers, index of location of general offices and shops of railroads, list of traveling representatives of railroad supply houses, tables and data for use of track department, lists of national and State railroad commissioners, railroad and technical associations and sleeping car and telegraph companies, with their officials. The publication is so well known as to require little at our hands except a statement that it is to be published monthly. This implies an immense amount of labor, which will without doubt be appreciated by those who have occasion to refer to the valuable information contained in the publication.

"Scientific American Supplement Reference Catalogue." This is a volume of 48 pages, bound in cloth, giving an index or catalogue of the valuable papers to be found in the "Scientific American Supplement." It is cross indexed, and the headings are in full-faced type, which contributes largely to its convenience. The list contains references to more than ten thousand of the more important articles, many having been omitted because of lack of space. The great value of this list lies in the fact that many of the subjects have not been treated in books. We are glad to have a copy of the catalogue and expect to find it exceedingly useful. We understand that the catalogue will be sent free upon application, by addressing Munn & Co., 361 Broadway, New York.

"Record of the 'Perfect' Truck, 'Brill No. 27.'" Under this title the J. G. Brill Company, of Philadelphia, has issued an illustrated pamphlet explaining the design and construction of the "Perfect" Truck and giving the reasons for its success. This truck is in use on many lines under the severe conditions imposed by a combination of open road and street railway working and the statement that after two years of service no case of derailment has been reported is abundantly supported. The pamphlet contains a number of remarkable letters from railway men who are using the trucks, one of which is quoted elsewhere in this issue. The letters are convincing of the merits of this truck, and as they come from Presidents, General Managers and Superintendents, the testimony is to be accepted as authoritative in the highest sense. Such remarks as these are found in them: "Does not leave the track," "Forty miles per hour with shallow flanges and narrow treads," "Have tried other trucks, but make 'No. 27' standard," "Are operating only your 'No. 27' truck," "A radical improvement," and "Never had one derailed under any conditions." The trucks are used under heavy as well as light cars, and the records are worthy of examination.

"Brown's Discipline of Railway Employees Without Suspension." This pamphlet, published at Easton, Pa., by the Railway Discipline Publishing Co., price 17 cents, is devoted to the explanation of the system of discipline first introduced by Mr. G. R. Brown, General Superintendent of the Fall Brook Railway. The book contains two articles by Mr. Brown giving a statement of his experience of thirteen years, which are followed by circulars of a large number of railroads that have adopted the system; it also presents private and public letters upon the subject. The book is in convenient form and

operating and mechanical officers of railroads should make a point of reading it.

"Cambria Steel Rails." The Cambria Iron Company, Philadelphia, Pa., whose works are at Johnstown, Pa., has published a volume of illustrations and tables of sections of T rails and their joints, a copy of which has just been received. This is Volume I. and is devoted entirely to T. rails, Volume II. being given to street or girder rails for electric railroad use. In Volume I. are full-sized sections of standard rails in most general use, with all dimensions given, and also the number of tons per mile of track. Accompanying each rail section is the corresponding splice section, and at the end of the book frog fillers, special splice bars and track bolts are illustrated. Tables referring to track bolts and their weight are included. Volume II. also contains sections of T rails, but is chiefly given to the special sections for street and electric use. These sections are also dimensioned and are drawn full size.

"Diamond 'S' Brake Shoe." The Sargent Company, Chicago, has issued an exceedingly handsome illustrated pamphlet, containing a report of tests on the laboratory brake shoe testing machine of the Master Car Builders' Association, on the "Diamond 'S' Brake Shoe." This report was published in abstract in our December issue of last year, page 424. The tests were conducted for the Sargent Company by Mr. J. C. Whitridge, of Chicago. Besides the report, the pamphlet contains comments and notes on service tests. This is one of the most attractive trade pamphlets that we have seen and it is worthy of preservation.

"Air Compressors." The Ingersoll-Sergeant Drill Co. This concern has just sent us a booklet $3\frac{1}{2}$ by $5\frac{1}{4}$ inches in size, which is a condensed illustrated edition of their catalogue of air compressors. It is a handy little volume that our readers ought to procure, which they may do by asking for it. Compressors in great variety are illustrated by good half tone cuts and on the pages opposite the various illustrations are lists of some of the users of these types.

"The Composite and Its Field," by C. Peter Clark, General Manager New England Railroad, Boston. This is an illustrated paper on the composite locomotive and car, a reprint of the paper read by Mr. Clark before the New England Railroad Club, December 14, 1897, and printed in abstract in our issue of January, current volume, page 29. It is a clear and comprehensive treatment of this interesting subject.

EXPERIMENTAL BALDWIN LOCOMOTIVE AT COLUMBIA UNIVERSITY.

We are informed by Professor F. R. Hutton, Professor of Mechanical Engineering, Columbia University, New York, that the engineering school of that university has just been presented with the locomotive "Columbia" by the Baldwin Locomotive Works. This is the engine that was exhibited at the World's Fair in 1893, and it is expected to be used as a laboratory locomotive on a plan similar to those carried out by Professor Goss at Purdue University, and by the Chicago & Northwestern Railway at its Chicago shops. The liberality of the Baldwin people will be appreciated by all who are interested in the subject of transportation by rail.

The engine is a "Vauclain Compound," designed by Mr. S. M. Vauclain. It is one of a group of exceedingly valuable machines recently given to the mechanical engineering department. C. C. Worthington has presented, in memory of his father, some hydraulic machinery valued at \$20,000. Besides pumps of notable capacity, his gift includes accumulators, meters and facilities for measuring the flow of water and the verification of formulas and constants. William W. Allis, of Milwaukee, has also contributed valuable machinery as a memorial to his father.

SHEFFIELD STANDPIPE NO. 6.

A new standpipe or water column has been introduced by the Sheffield Car Company, of Three Rivers, Mich., which is illustrated by the accompanying engraving. The objects toward which these manufacturers have worked in all of their water columns are a spout that may be moved vertically and horizontally, a protection of the column from injury by

water hammer, automatic drainage of the column and satisfactory control of the valve, by which the speed of opening and closing may be regulated by the man who operates it.

This new column provides a free passage of water and the valve, being horizontal, admits the water to the vertical column without the obstruction of an extra turn in its course. The mechanism is arranged on the outside of the pipe for easy access. The operating lever is placed convenient to the fireman's hand and the motion required to operate the valve

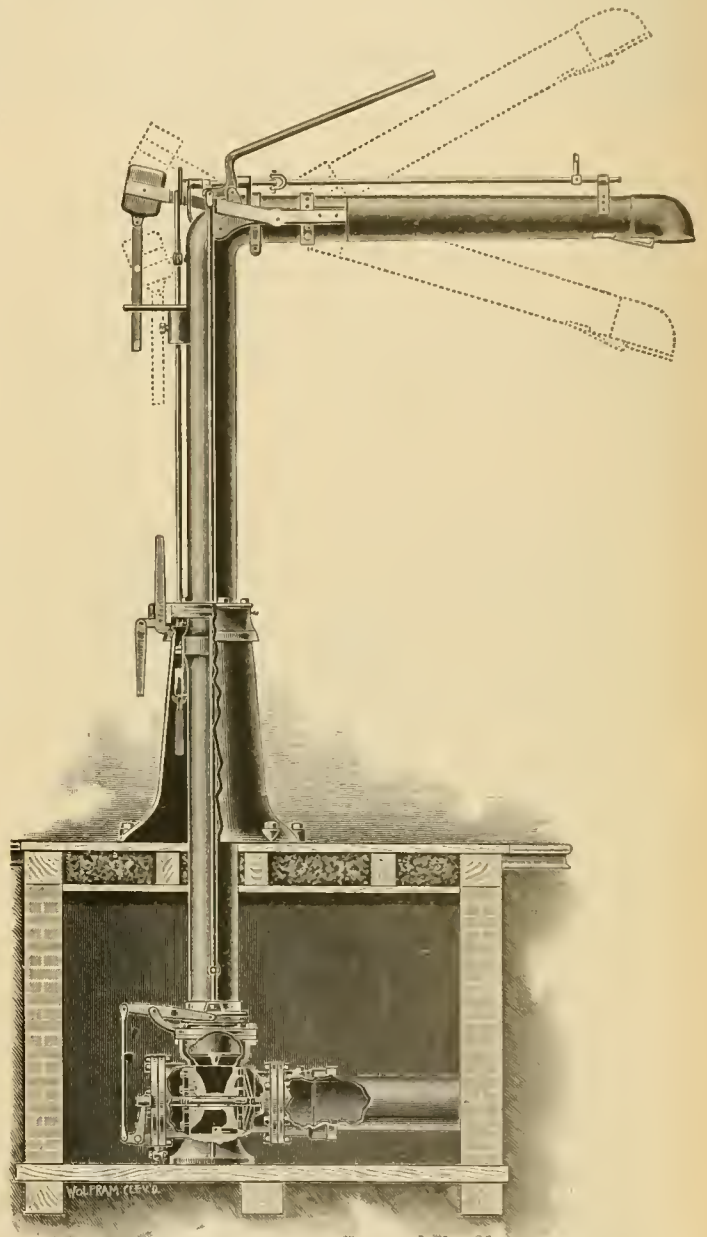

The Sheffield Improved Standpipe No. 6.

is a very small one. The construction of the valve chamber is such as to permit the removal of the valve entirely by taking off the head of the casing. The cylinder is lined with brass and is not liable to corrosion, and the valve is provided with a rubber seat to secure tightness under all pressures used. The joint in the delivery arm of the pipe is of rubber, specially prepared to resist the action of cold weather. The vertical adjustment accommodates varying heights of tenders, and there is no drip from the end of this pipe to cause icy tracks.

The delivery arm is counterweighted, and the entire weight of the column is carried upon a center bearing at the lower

end of the vertical pipe. A positive lock is provided to secure the pipe in position when it is thrown parallel to the track.

The construction of the main valve is shown in the engraving. It has two disks, one of which is the valve proper, while the other is an hydraulic piston, which is controlled by an operating valve, worked by a rod passing through the center of the main valve and into a guide bar, which is cast in the valve seat. The operating valve controls the passage of water from the main pipe to the hydraulic cylinder, and it also controls the exhaust from that cylinder into the water column, and as the piston is of larger area than the valve, the pressure of the water against it will close the valve and hold it against its seat, while relief from this pressure will allow the valve to open. Sand which may accumulate in the cylinder may be washed out through a small cock provided for the purpose.

DOUBLE STACK LOCOMOTIVES—TOLEDO, PEORIA & WESTERN RAILWAY.

Several devices have been introduced for the purpose of improving the draft arrangements of locomotives and efforts in this direction have not been confined to this country alone, no less an authority than Mr. F. W. Webb, chief mechanical superintendent of the London & Northwestern, having recently produced a design having two exhaust pipes and a horizontal partition across the smoke box. This was done to secure a more equal distribution of draft between the top

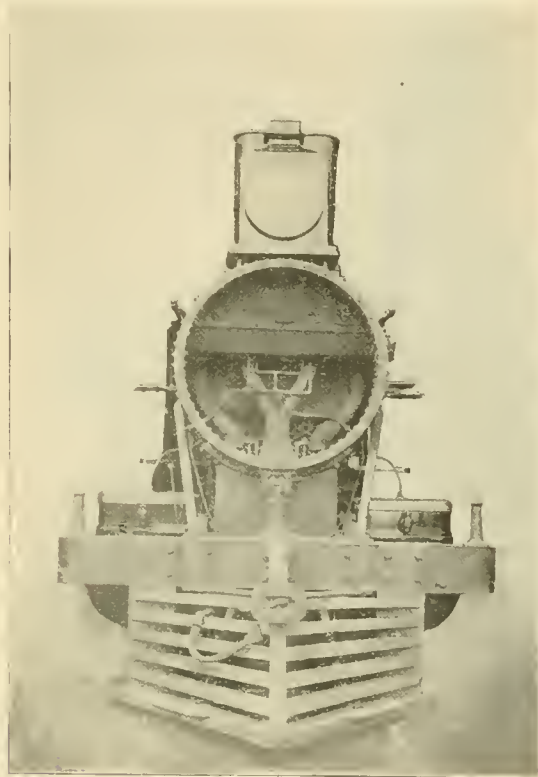

Double Stack Locomotive.

and bottom flues. The device used on the Toledo, Peoria & Western has a similar object, the equalizing of the draft, but there is no partition in the smoke box, and the equal distribution of draft between the center and the outside flues is specially sought in this case.

The engravings illustrate the device as applied to a Rogers locomotive of the consolidation type; they show the stacks to be side by side, instead of in tandem, as in the English engine referred to. The exhaust pipe is double, and of such a form as to lead the exhaust from each cylinder into both stacks. The sectional view shows the form of the exhaust pipe and

the arrangement of the netting. The chief claims made for the arrangement are, the production of an even draft through all of the tubes; an increase in size of exhaust nozzles over other practice, a saving of wear on boiler flues, and a saving of fuel.

The device has been tried for several years on the Toledo, Peoria & Western Railway, and also on the St. Louis, Chicago & St. Paul, good records having been made on both lines. In July and August, 1896, tests were made on regular passenger trains on the Toledo, Peoria & Western, the engines having 16 by 24-inch cylinders, and making two round trips on the Western division, from Peoria to Keokuk, 113 miles. The engines were in equally good condition and differed only as to the draft appliances. They both made the same number of

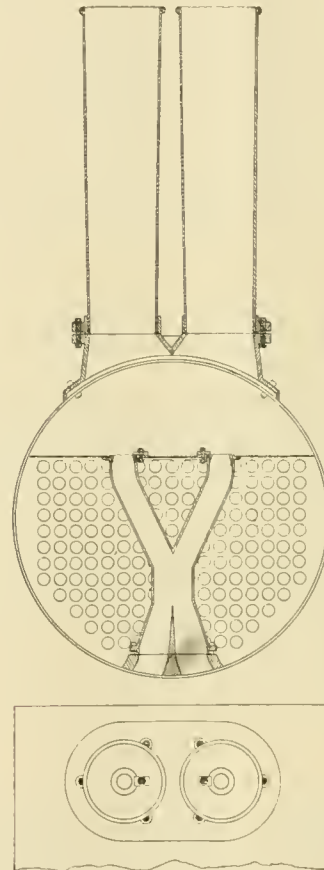

Double Stack Locomotive.

stops, 25 in 100 miles run. Other comparisons were made on five 16 by 24-inch passenger engines, three with double stacks and two with ordinary stacks, each making two round trips on the Eastern division, from Peoria to Effner, 111 miles. All the engines were in equally good condition and all made the same number of stops. The records are as follows:

WESTERN DIVISION—PEORIA TO KEOKUK.

	Average double stack.	Average single stack.	Percentage favor double stack.
Ton miles per train per trip....	16,950	16,950	0
Aver. speed in miles per hour..	33.50	32.60	3 per ct.
Pounds water evaporated per pound of coal.....	5.50	5.00	10 per ct.
Miles run per ton of coal.....	55.80	50.60	11 per ct.
Pounds coal to haul 1 ton 1 mile	.239	.259	8 per ct.

EASTERN DIVISION—PEORIA TO EFFNER.

	Average double stack.	Average single stack.	Percentage favor double stack.
Ton miles per train per trip....	16,474	16,420	33 per ct.
Aver. speed in miles per hour..	40.80	40.60	50 per ct.
Pounds water evaporated per pound of coal.....	5.00	4.60	9 per ct.
Miles run per ton of coal.....	39.20	35.80	11 per ct.
Pounds coal to haul 1 ton 1 mile	.345	.372	8 per ct.

Mr. W. B. Warren, general foreman of the Toledo, Peoria & Western Railroad, designed and patented this arrangement, and we are indebted to him for the photographs and results

THE EMPIRE AIR HOIST.

This air hoist is an application of two rotary air motors to a differential chain hoist and has the well-known advantages of the chain hoist. The motors are about two horse-power each, they are reversible and are fitted between the two side plates that form the frame of the hoist. Pinions on the ends of the motor shafts mesh directly with large driving gear wheels, which operate the hoist by means of two differential chain wheels. The whole device, when built for a capacity of 5,000 pounds, occupies a space 42 inches high, 21 inches wide and 15½ inches deep when the hook is drawn up. The total weight is 241 pounds, and that of a single motor is 29½ pounds.

The motors are most carefully made and their design is such as to meet many of the objections which have been raised to

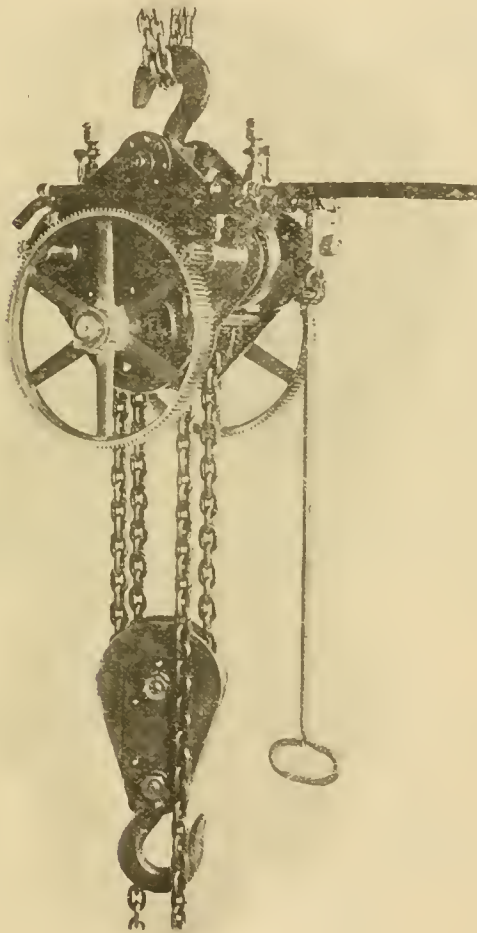

Empire 5,000-Pound Air Hoist.

the rotary type. The wings are not set out by springs, but by a positive adjustment, as they are of phosphor bronze, as hard as can be made, and ground accurately to fit the casing; good wearing qualities may be expected and the remarkably small number of parts should contribute to this desideratum. The construction is done on jigs for the sake of interchangeability, such care being given to this feature as to lead the manufacturers to urge this as a claim for superiority.

The hoist has advantages over those in most common use, in that it occupies little head room and is adjustable to an indefinite extent as regards length of lift, a lift of ten feet being ordinarily provided for. Like a chain hoist, it will hold its load and it does this without strain on the motors, and the control of the motors is such that accurate lifting in handling machinery in lathes or other tools may be had. Air hoists have contributed very materially to the cheapening of mechanical operations in shops and the progress in their use has been

remarkable. The direct acting cylinder air hoist has done its work admirably, and now the want of a better device which will be free from the troublesome effects of leakage and lack of sustaining power, as well as one which does not require head room equal to the lift, is recognized. In the hoist under consideration there is no piston packing working against a more or less rough cylinder, no danger of leaky valves, pipping or piston packing, which will lower the load, and no spring to the hoist when part or the whole of the load is removed. The operation of the motors is controlled by a valve which starts, stops and reverses them, and is worked by a handle shown at the right hand side of the hoist in the illustration. Further information will be supplied by Mr. F. V. Green, of the Empire Engine and Motor Company, 26 Cortlandt street, New York, the manufacturers of this hoist.

ECONOMICAL LOCOMOTIVES.

At a recent meeting of the St. Louis Railway Club Mr. G. W. Rhodes, superintendent of motive power of the C., E. & Q. R. R., spoke on the subject of the economical locomotive and its relation to the track, in part, as follows:

I would say, in a general way, that for railroads in our immediate surroundings, beyond any question, the best engine for both passenger and freight service is what is known as the four-wheel connected 17 or 18 by 24-inch American engine; that is a good engine for pioneer roads and for roads that have not been rebuilt. I want to lay a great deal of stress on the fact that it is the condition of a railroad which governs the question as to what is the best passenger engine and what is the best freight engine.

I will cite a case that we are all pretty familiar with, and that is the matter of bicycles. The people who live out in the country and who have the arduous duty of furnishing the power to get a bicycle over the road, they know what a great difference there is in the character of the road, and in the condition of the road. You take it in Chicago, and I have no doubt in St. Louis also, where we have good roads, good asphalt pavement, and the amount of work that we can perform on a bicycle, the amount of speed that we can make and the ground that we can cover is very much greater than it would be out on some up-and-down, badly constructed road. We can do more work with the same power on a bicycle when we have a good underbed to work on than we can when we have a bad underbed to work on. And it is the same way with an engine. You can do more work with an engine when you have a good underground to work on than you can if you have a bad underground to work on.

Formerly it was the practice to send specifications and drawings to the locomotive builders, and the builder would simply build the engine. That method is gradually changing, and the practice that we are gradually getting into is to specify a condition. To specify a condition in time that the trains are expected to make between two points; to specify the character of rail that is laid; to specify the character of grade, the weight of the trains and the curvature, and then to ask the locomotive builders to build the engine that will do this work and also guarantee that the engine will perform it, and the payment is not made until the engine does perform it. So it is pretty clear, I think, that the conditions govern the question as to what is the best passenger engine and what is the best freight engine.

There is another feature of this subject, as to the change which improved conditions of the road will bring about in engines. I think that it is often the case that new engine construction has been spoiled by the overconfidence of the motive power men, and very often the overconfidence of the manager of the railroad, in the representations which are made to them requiring a new type of engine. My experience has been that when a new engine is built, whether it is built at a railroad company's shop or whether it is built at the shop of a locomotive builder, it will be found that in a great many particulars the engine is decidedly weak; that the best calculations have not been able to make the engine strong enough; at first in one part and then in another part the machine fails, and then a third part will fail, and as those failures occur the parts are strengthened, and finally, after a few years' service, this new type of engine is reconstructed and rebuilt in such a way that it is strong enough to go into general service and you are ready to have more engines of that class built.

Now, the mistake that is made very often is in the overconfidence of some builder or the overconfidence of some superintendent of machinery, who will order a dozen or fifteen or twenty engines of a new type, and then, in place of having these failures occur on a single engine, they occur on twenty or thirty, the effect being that it practically condemns the entire lot after being used on the road, whereas, if but one engine had been purchased, it might have been worked into a good engine by remedying these defects as they were discovered. Therefore, I would advise those who wish to make a change in their type of engine not to build fifteen or twenty of the same kind at once, but confine themselves to one, and make a thorough test of that one engine before introducing a large number on the road.

In concluding, I would endeavor to impress upon members of the club and the railroads generally that what we want is, to my mind, more mechanics in the track at the present time, rather than more work in the locomotive.

In the same discussion Mr. J. A. Carney, master mechanic of the C., B. & Q. R. R., made the following remarks with reference to small locomotives:

Has the small engine seen its day? This is a question so much dependent upon local conditions that it cannot be answered definitely yes or no, and might be supplemented by the question: "Has the large engine seen its limit, and is it the engine to be desired for all classes of service?"

The majority of the small engines of to-day are the remains of what was once the main equipment of many of our railroads, and it is their light weight and low boiler pressure that makes them small. In merchandise freight and stock trains, and in fast passenger and mail service these engines are out-classed by the large engine, and they failed principally because of their lack of boiler capacity.

The principal advantages of the large over the small engines are: First, they haul more cars; second, it costs less per car mile in wages to haul them.

The amount of fuel per loaded freight car mile is about the same whether the engine be large or small. The cost of repairs of the small engine is decidedly in its favor. Therefore, in comparing large and small engines in freight service, there is little choice so far as fuel consumption is concerned. The extra cost of repairs of the large engine is entirely overshadowed by the saving in train crews' wages, and in its extra earning capacity, so that for average main-line work the small engine has seen its day. On the Northern Pacific the purchase of 50 heavy engines has been the means of laying up 95 small engines. What the saving has been I am unable to learn, but it must be large enough to fully warrant the change. Where the traffic is large and the grade heavy, as it is in portions of the Northern Pacific, the large engine has become a necessity. About 25 per cent. of the savings in engines has been accomplished by making longer runs. Some of the more level roads have adopted the medium-sized engines, and have spent money in leveling and straightening their permanent way that otherwise would have been spent in the purchase of larger engines. On such a road the medium-size engine will haul almost all the cars that can be put behind it, and in many cases the length of the train is limited by the length of the sidings.

The small engine is still being used on branch lines where the freight business is not large enough to warrant the use of a large engine, and where, in many cases light track and light bridges would not permit of the use of larger engines even if the service demanded it. For branch passenger work and light suburban service the small engine answers every purpose, and will be maintained for that class of service. The great disadvantage of the small engine of to-day is its low boiler pressure, and the small engine of the future will be one which is capable of carrying 160 to 180 or more pounds of steam. That there are too many small engines to-day there can be no question. Many of them will be replaced by large engines, and a few will be rebuilt with boilers capable of carrying high pressure.

In conclusion, the size of an engine depends upon the service required of it, and for certain classes of work the small engine is just as much in demand to-day as it was 20 years ago.

TESTS ON THE CHICAGO STORAGE BATTERY RAILROAD.

It is well known that the Englewood & Chicago Electric Steel Railway has operated 20 cars on its lines using the storage battery, and at the beginning of this winter it was decided

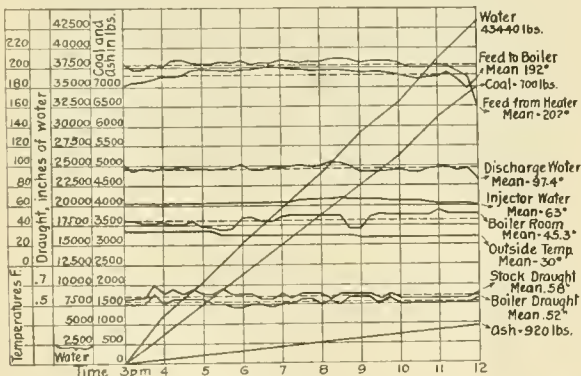

Fig. 1—Boiler Test.

to test the plant in order to determine the presence and extent of defects which might otherwise exist without attracting attention. The tests were made under ordinary working conditions and represent the conditions of usual practice. They were carried out by Mr. George A. Damon, assisted by Prof. T.

P. Gaylord and a corps of students from the Armour Institute. We are indebted to Mr. G. Herbert Condit and to the "Western Electrician" for the data and diagrams.

The boiler plant includes three Heine water-tube boilers rated at 200 boiler horse-power each, fitted with Roney mechanical stokers. The engines are triple expansion, condensing, of the Willans central-valve type made by the M. C. Bullock Manufacturing Company, of Chicago. The plant at present contains two of these engines, each of which has two lines of tandem

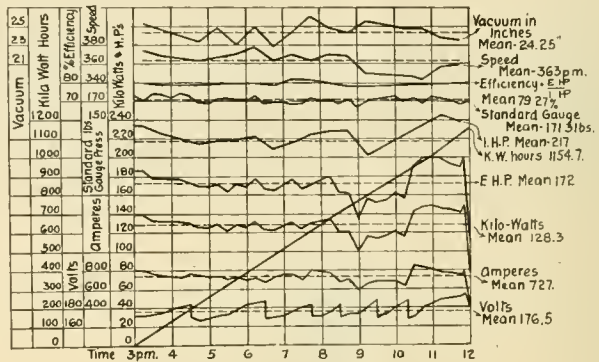

Fig. 2—Engine and Generator Tests.

cylinders rated at 200 horse power at a speed of 380 revolutions per minute.

The engines are directly connected by the "Arnold" method to four six-pole, shunt-wound Walker generators, rated at 190 KW. each when running at 380 revolutions per minute.

Each engine exhausts into a Worthington jet condenser, from which the condensed steam and heated injection water is raised by means of the air pump about 35 feet to the top of a Worthington cooling tower, in the bottom of which it collects, ready to be again used in the condenser.

The boiler feed pumps are of the Worthington duplex compound type, and ordinarily take their supply from the well of the cooling tower, pumping it through a closed feed-water heater in the exhaust line of the pumps, and thence through the economizer to a common feed-water heater above the boilers.

The hot flue gases from the boilers pass from the uptakes into a brick smoke flue extending the entire length of the boiler room. In a brickwork extension of this flue, located between the power house proper and the stack, is installed a Green economizer, with passages and dampers so arranged that the

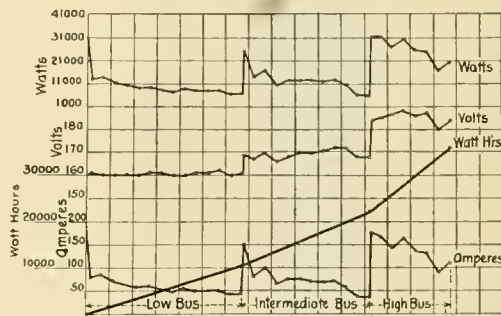

Fig. 3—Charges of Storage Battery Cells.

economizer pipes may be made to intercept the hot flue gases.

Several tests were made, and those to which we direct attention were made on Nov. 26, and Fig. 1 shows the results of the boiler test on that day, while Fig. 2 gives the data obtained from tests on the engines and generators at the same time.

The tests were made on one boiler, one engine and two generators, and the three-voltage method of charging the batteries was not used in these cases. The price of the coal at the plant was \$1.90 per ton, and from five tests its calorific value was found to be 10,145 B. T. U. per pound. It had 48 per cent. fixed carbon, 33 per cent. volatile matter and combustible, 6 per cent. of moisture, 3 per cent. sulphur and 10 per cent. of ash. The cards were taken every thirty minutes and showed an average indicated horse-power of 217, and an average electrical horse-power of 172, with an average all-day efficiency of 79.3 per cent. The theoretical evaporative efficiency of 10.5 pounds of water per pound of coal, and the evaporation from and at 212 degrees per pound of dry coal, was 6.6, giving an efficiency of the boiler and firebox of 62.86 per cent., which was obtained while the boiler was 26 per cent. under-loaded. The equivalent evaporation per pound of combustible was 8.22, so that the efficiency of the boiler alone was 78.3 per cent., and the boiler losses by radiation and other causes 21.7 per cent., while the fur-

nance is to be charged with 14.44 per cent. of the lost heat, and the remainder 62.86 per cent. appears in the steam.

The test shows that the engines used 18 pounds of steam per indicated horse-power, but it should be remembered that among the unfavorable conditions, the engines were overloaded and had a vacuum of but 2¼ inches. The indicator cards taken with one engine operating one generator showed a friction load of 32.26 indicated horse-power, which is but about 15 per cent. of the average indicated horse-power. The commercial efficiency of the generator is shown to be 93.1 per cent., which efficiency

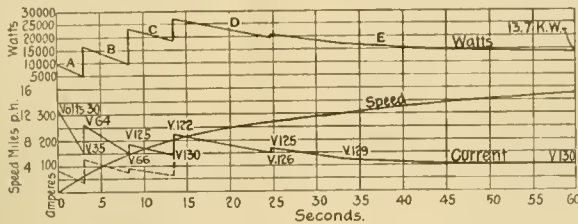

Fig. 4—Average of Five Acceleration Tests.

was obtained when the generator was running 32 per cent. below its rated capacity. The total efficiency from the coal pile to the switchboard was 5.58 per cent. The cost of fuel for a net kilowatt hour on the switchboard of the station tested is shown to be .611 cent. As the result of a two days' run with coal at the price named the cost of fuel per car mile was .996 cent, and the pounds of coal per net kilowatt hour were 6.44.

Fig 3 gives the result of the readings taken on one of the cars every five minutes during the test while it was performing regular service, and Fig. 4 shows the results of a speed trial for 60 seconds. In this figure A, B, C, D and E were the readings obtained for the watts used, while the controller was placed at the five points representing the connections as follows: A, the four sets of batteries in parallel; B, batteries in series parallel in sets of two; C, batteries in series with resistance; D, batteries in series without resistance; E, same as D with field of motor shunted. The speed of 15 miles an hour attained at the end of the 60 seconds was after a run of 986 feet, showing at a glance that it is hardly worthy of comparison with the speed of electric and other cars which have been recorded, but the equipment of this car was designed to enable it to attain normally a speed of but 15 miles an hour. The tests were made on a 13½ ton car, driven by a 50 horse-power Walker four-pole series motor. The entire current used at any one time passed through the armature, so that the ammeter was inserted in the positive brush leads.

The results of the tests point to the suggestion that the engines should be overhauled, the economizer flue repaired, and the question of securing improvements in the fuel as to quality and cost should be taken up.

A STEEL FRAME BOX-CAR.

In an interesting paper, read at the December (1897) meeting of the Northwest Railway Club, Mr. H. H. Vaughan presented a design for a 40-foot, 60,000-pound box-car which has some

provided for entirely by the car sides, and the center sills are supported and are used for local strength and for the pulling and bulging stresses. The car is 8 feet 6 inches wide over the side sills and has a total floor space of 330 square feet, which will accommodate a load of 60,000 pounds. Mr. Vaughan describes the design in the following words:

The general design is shown by Fig. 1, and it will be seen that the truss is of the ordinary "N" type, with posts in compression. The transoms are 30 feet centers, and the floor is carried by four beams at the panel points, which are spaced about 6 feet apart. Each of these floor beams would carry a load of 9,300 pounds if the load were uniformly distributed, but I consider that the possibility of heavy local loading must be taken into account, and for this I have allowed a double load of 18,600 pounds on one floor beam, but under these circumstances have taken the load on the adjacent floor beams at 4,700 pounds, making as before a total of 28,000 pounds for three beams. I believe that such an assumption will be found to

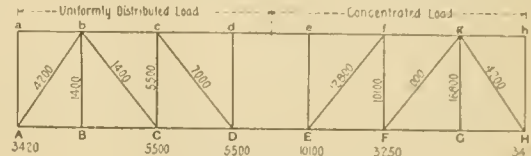

Fig. 2—Stress Diagram.

meet all cases that will be encountered in practice, as no machinery or metal will be loaded that would give rise to greater local weights.

The diagram Fig. 2 shows the stresses on the framing, the left-hand side being for a uniformly distributed load and the right-hand side for a load concentrated as above described, but symmetrical with respect to the center. The weight of the frame sheathing, roof, etc., is included. The allowable stresses in the various members are taken as follows:

On framing, 12,500 pounds per square inch for tension, 8,000 pounds per square inch for compression.

On rivets, 7,500 pounds for shearing, 15,000 pounds per square inch for bearing.

By reference to Fig. 1 it will be seen that the posts and braces are made of 3-inch channel, 5 pounds per foot, and the maximum stress will be 10,000 pounds for tension and 6,800 for compression. The transom post is a 5-inch channel, 6.5 pounds per foot, and the stress on it is 7,600 pounds per square inch. The side plate is a 4-inch channel 5.5 pounds per foot; the maximum strain for this occurs between the door posts, and for a uniform load is 8,300 pounds per square inch, but as this is a continuous section, an excess is perfectly allowable, and it is prevented from buckling sideways by the roof, fascia boards and door track.

The buffing and pulling strains in this car are taken by two 10-inch channels, 16.5 pounds per foot, which run the entire length of the car. The combined area of these is 9.8 square inches, or as great as that in the shank of the coupler and in my opinion should be strong enough to resist any shock that will not entirely wreck the car. The collapsing strength as a column is about equal that of the four center sills in a 60,000-pound car, and would appear ample by that comparison.

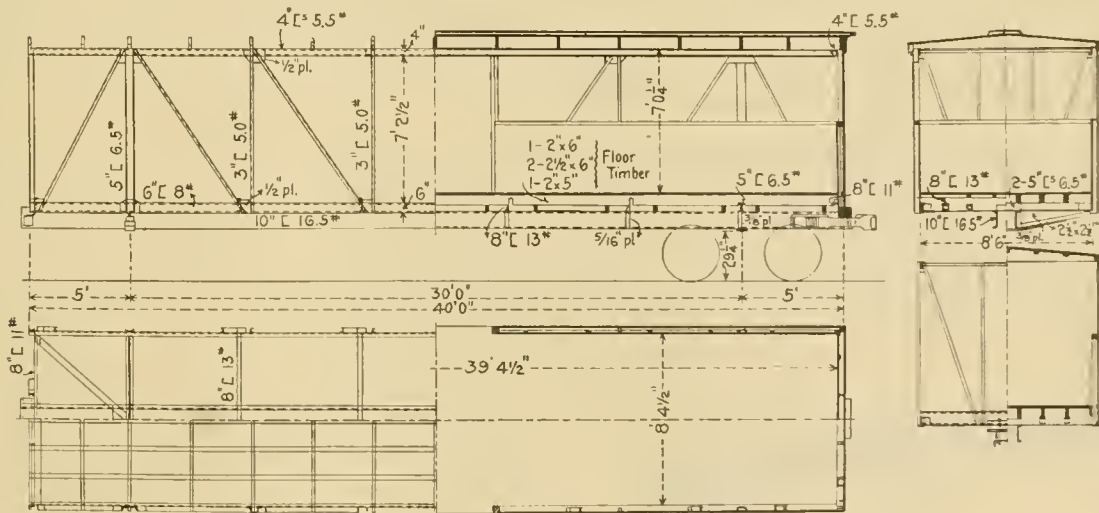

Fig. 1—Design for 60,000-Pounds Capacity Box-Car.

novel features, among the most important of which is the use of the side framing of the upper part of the car for carrying the load, the object of this being to reduce the weight of the car to the lowest terms. The load in Mr. Vaughan's design is

The paper also treats of the resistance to bulging of the ends and sides of the car, showing the necessity for providing for these stresses especially in steel members acting as struts, because the fiber stresses increase very rapidly under combined

compression and bending, and also because steel has less margin between elastic limit and rupture than wood. To guard against these stresses the three-inch channels shown at posts and braces are placed with their webs at right angles to the sides, or the ends, of the car, which gives a strength of about four times that of wooden posts. Another feature of the design is the arrangement of the posts so that the loads come upon the outside of the posts at the top ends and are transmitted to the car at the bottom on the inside of the posts whereby the eccentric loading is almost entirely neutralized. To guard

specially for this purpose, and to this the brake heads, fulcrums and guards are attached. Besides the five-inch I beam, five malleable iron castings and the guards complete the structure, which weighs 80 pounds. The wheel guards are secured to the beam by clips held in place by an eye bolt, to which the safety hangers are attached. The guard pins are removed by loosening this eye bolt and new ones may be put in without difficulty. The pin is held in position by being notched to fit the edge of the flange of the beam, against

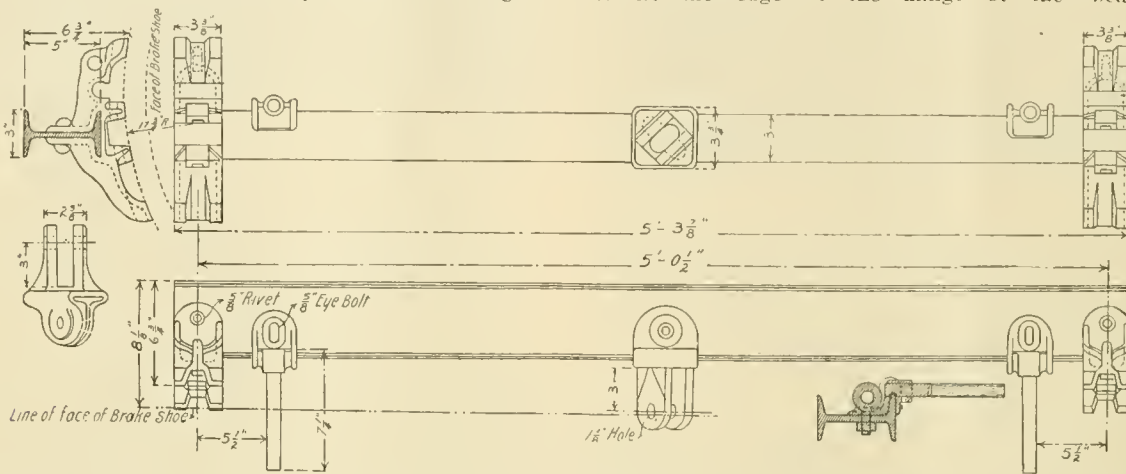

The "Solid" Brakebeam.

against stresses caused by poling or pushing the car from one corner, the designer uses diagonal braces from the corners of the car to the centers of the body bolsters. He considered it desirable to attach the draft rigging directly to the sills by riveting, which would probably save repairs.

The weight of a car body built on this plan was put at 17,500 pounds, which included all attachments and fittings above the trucks. The details of the weight are as follows:

	Pounds.
Steel frame with centerplates and attached castings.....	6,440
Floor beams, belt rails and railing strips.....	1,350
Roof and running board lumber.....	2,150
Sheeting, side and end door lumber.....	2,470
Floor.....	1,270
Coupler and draft rigging, deadwood, etc.....	1,220
Brakes.....	1,980
Side and end door iron work.....	220
Hand holds, corner plates, etc.....	250
Bolts, nuts, etc.....	160
Total.....	17,510

The total weight of a wooden car body of this size and capacity was 20,000 pounds, or 2,500 pounds more than that of the steel car, the difference being in the first two items in the list. Allowing for variations which might be required in his design after placing it in service, the author considered one ton per car to be the amount saved by his design over a wooden car. Then by figuring on the car mileage he places the cost of hauling one ton of extra weight in a car for a year at \$27.00; this amount, and probably also a saving in the cost of repairs, should be credited to the use of such a car.

In conclusion, Mr. Vaughan says: "The trussed frame car in some form or other offers the lightest car for a given capacity, and while it is less sturdy than those with metal underframe alone, it appears to me the most advantageous form to use."

THE "SOLID" BRAKEBEAM.

A new brakebeam has just been introduced by the Monarch Brakebeam Company, of Detroit, Mich., manufacturers of



The "Solid" Brakebeam.

the beam which was illustrated on page 381 of our issue of November, 1897. The new beam is made of an I beam, rolled

which it is pressed by the clip. The details of construction are clearly shown in the engraving. The brake heads are interchangeable and are strengthened by double ribs and the same head is used for either outside or inside hung brakes. A special claim for strength is made for the beam, which is guaranteed by the manufacturers to stand the Master Car Builders' test.

COMPOUND CONSOLIDATION LOCOMOTIVES—OGDENSBURG & LAKE CHAMPLAIN RAILROAD.

The Schenectady Locomotive Works have just completed a compound consolidation locomotive for the Ogdensburg & Lake Champlain Railroad, the chief dimensions of which are given in the accompanying table, and the general appearance of which is shown in the engraving prepared from a photograph. The engine has Allen-American balanced valves, McIntosh blow-off cock, Westinghouse-American brake on drivers and tender and for train, magnesia sectional lagging by the Keasbey & Mattison Company of Ambler, Pa., and the Leach track sander. The chief characteristics of the design are as follows:

General Dimensions.	
Gage.....	4 feet 5 1/2 inches
Fuel.....	Bituminous coal
Weight in working order.....	155,000 pounds
" on drivers.....	135,500 pounds
Wheel base, driving.....	15 feet
" rigid.....	15 feet
" total.....	22 feet 10 inches
Cylinders.	
Diam. of cylinders.....	H. P. 22 inches, L. P. 34 inches
Stroke of piston.....	28 inches
Horizontal thickness of piston.....	5 3/4 inches and 4 3/4 inches
Diam. of piston rod.....	3 3/4 inches
Kind " " packing.....	cast iron rings
" " rod packing.....	Jerome metallic
Valves.	
Kind of slide valves.....	Allen-American balanced
Greatest travel of slide valves.....	6 1/2 inches
Outside lap " ".....	H. P. 1 1/4 inches; L. P. 1 3/8 inches
Inside clearance " ".....	1/8 inch
Kind of valve stem packing.....	Jerome metallic
Wheels, etc.	
Diam. of driving wheels outside of tire.....	54 inches
" " centers.....	Cast steel
Driving box material.....	Main, cast steel; balance, steeled cast iron
Diam. and length of driving journals.....	Main, 8 1/2 inches diam. x 11 inches; balance, 8 inches diam. x 11 inches
" " main crank pin journals.....	6 1/2 inches x 6 inches
" " main side.....	7 inches diam. x 5 1/4 inches
" " side rod crank pin journals.....	Intermediate, 5 1/2 inches x 5 inches; F & B., 5 inches diam. x 2 3/4 inches

Engine truck, kind.....	Two wheel, swing bolster
" " journals.....	6 inches diam. × 11 inches
Diam. of engine truck wheels.....	30 inches
Kind.....	Standard, cast steel spoke center
Boiler.	
Style.....	Extended wagon top
Outside diam. of first ring.....	62 inches
Working pressure.....	200 pounds
Material of barrel and outside of firebox.....	Carbon steel
Thickness of plates in barrel and outside of firebox.....	$\frac{3}{8}$ inch, 11-16 inch, $\frac{1}{2}$ inch and 7-16 inch
Firebox, length.....	108 3-16 inches
" " width.....	41 inches
" " depth.....	F, 67 $\frac{7}{8}$ inches; B, 64 $\frac{7}{8}$ inches
" " material.....	Carbon steel
" " plates, thickness.....	Sides, 5-16 inch; back, 5-16 inch; crown, $\frac{3}{8}$ inch; tube sheet, $\frac{1}{2}$ inch
" " water space.....	Front, 4 inches; sides, 3 $\frac{1}{2}$ to 4 inches; back, 3 $\frac{1}{2}$ to 4 $\frac{1}{2}$ inches
" " crown staylag.....	Radial stays, 1 $\frac{1}{4}$ inches diam.
Tubes, material.....	Charcoal iron, No. 12 W. G.
" " number of.....	306
" " diameter.....	2 inches
" " length over tube sheets.....	13 feet
Fire brick arch, supported on.....	Water tubes
Heating surface, tubes.....	2,069.5 square feet
" " water tubes.....	11.5 square feet
" " firebox.....	162.1 square feet
" " total.....	2,243.1 square feet
Grate.....	30.8 square feet
" " style.....	Rocking, with drop plate
Ash pan, style.....	Sectional, with dampers front and back
Exhaust pipes.....	Single, high nozzles
" " nozzles.....	5 $\frac{1}{4}$ inches, 5 $\frac{1}{2}$ inches and 5 $\frac{3}{4}$ inches diam.
Smokestack, inside diameter.....	18 inches at top, 16 inches near bottom
" " top above rail.....	14 feet 1 $\frac{1}{4}$ inches
Boiler supplied by.....	Two injectors, Monitor, No. 10, R. & L. Tender.
Weight, empty.....	36,300 pounds
Wheels, number of.....	8
" " diameter.....	33 inches
Journals, diameter and length.....	4 $\frac{1}{2}$ inches diam. × 8 inches
Wheel base.....	15 feet 3 inches

tional forms, has served to make it more and more relied upon by the makers of low-priced insulating materials. Its price, indeed, is the only quality which can induce any one to employ it. Its lack of stability to resist for any great length of time the action of high temperature, its corrosive action on iron surfaces with which it comes in contact, are drawbacks too pronounced to permit serious consideration of this material by the thoughtful steam users to whom first cost is not the only consideration.

Asbestos is a commercial name for the fibrous form of the minerals amphibole and serpentine. It is really a very valuable mineral. The rock, dissected, yielding fiber fine and silk-like, yet defying furnace heat and chemists' acid.

Among the many uses for which asbestos is employed is the jacketing of heated surfaces for preventing radiation. Like charity, however, it has been made to "cover a multitude of sins," to stand sponsor for a mongrel brood of half-breed coverings and bastard laggings. The constant appropriation of the name asbestos to multitudes of mixtures claiming recognition as non-conducting coverings, justifies a more than passing notice of this substance at this moment. It has long been known that sheep's wool, cotton-wool, hair-felt and other organic fibrous matter possessed great virtues as non-conductors of heat. The large proportion of entrapped air within the interstices of the fibers gives to such materials a power for insulation unknown in the past in mineral substances. No wonder then than the use of asbestos as a lagging with its fibrous, feathery, hair-like structure, and its fire-resistant qualities, should have seemed so full of promise as a guardian of the fugitive thermal unit. Experience soon taught us, though, that

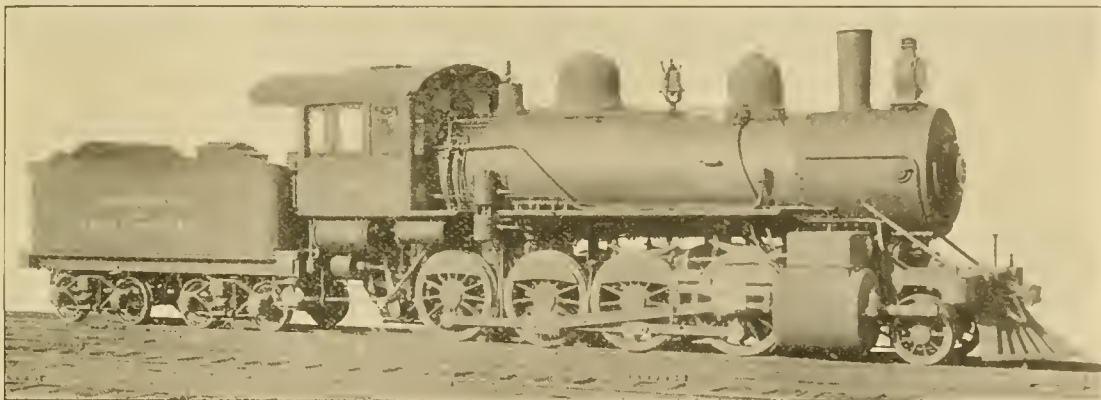

Schenectady Compound Consolidation Locomotive for the Ogdensburg & Lake Champlain Railroad.

Tender frame.....	30 inch steel channels
" " " " trucks.....	4 wheel channel iron, Cen. bearing P. & B., additional side bearings on back truck
Water capacity.....	4,000 U. S. gals.
Coal.....	7 $\frac{1}{2}$ (2,000 pound) tons
Total wheel base of engine and tender.....	49 feet 11 inches
" " " " length.....	59 feet 5 inches

LOCOMOTIVE BOILER LAGGING.*

By Wallace W. Johnson.

Under present conditions of knowledge and methods of engine building, the most vulnerable point in our practice remains the same to-day as in the day of Watt, who laid down this principle, that "The cylinders should be kept as hot as the steam which enters them."

Asbestos and magnesia have been names to conjure with during the past few years. And perhaps this would be an opportune time to remind the members of this club not to be misled by names. When a man, or a company puts out a covering, the substance of which is supposed to be described by the name it bears, I submit that in all fairness, it ought to contain a sufficient amount of the specified material to justify its name; but such is not always the case.

Plaster of paris, or sulphate of lime, is the principal constituent of many of the coverings now found upon the market. Its insignificant cost, the ease and cheapness of moulding it into sec-

one very vital quality possessed by the organic fibers, namely, elasticity, was lacking to a very considerable extent in asbestos fibers. Light, fleecy asbestos fibers make a very excellent non-conductor, if properly made up; but the vibrations, concussions and mechanical stresses to which boiler coverings are subjected soon break down the air-entrapped structure of asbestos wool, leaving a matted mass of mineral matter, sadly lacking the heat-entrapping air cells.

About sixteen years ago Prof. J. M. Ordway, at that time connected with the Massachusetts Institute of Technology, made a very exhaustive investigation at the instance of the Boston Manufacturers' Mutual Fire Insurance Company, regarding the non-heat-conductivity of a number of materials. Some of the substances tested, although possessing non-conducting properties of the highest order, were deemed unsafe or unfit for boiler or pipe covering, on account of their liability to carbonize, or take fire, or because of their corrosive action upon iron.

Prof. Ordway, in commenting upon some of the materials he had been testing, especially those of a fibrous character, said: "These substances keep the air still by virtue of their fibers or particles. The asbestos of 18 had smooth fibers which could not prevent the air from moving about. Later trials with an asbestos of exceedingly fine fibers have made a somewhat better showing, but asbestos is really a poor non-conductor. By reason of its fibrous character it may be used advantageously to hold together other incombustible substances."

Mineral wool consists of the slag from iron furnaces blown into a fibrous condition when melted. It is an excellent non-heat conductor when in a fluffy condition, by reason of the large

* From a paper read February 17, 1898, before the New York Railroad Club.

amount of entrapped air it will hold; but when converted into a solid condition, it becomes a rather quick conductor.

Magnesium carbonate, popularly known as magnesia, possesses the quality of porosity to a higher degree than any other mineral. One hundred volumes of carbonate magnesium will hold entrapped, from eighty-five to ninety volumes of air. It is by virtue of this great proportion of air cells that it possesses its well known heat insulating qualities. In the magnesia covering placed upon the market we find asbestos fiber to the extent of about one-tenth of the weight of the covering. The office of the asbestos as previously indicated is, by reason of its fine fibrous character, to lend mechanical strength to the covering, while the magnesia furnishes the insulating property.

COMBINATION SPRING PLANK, SPRING SEAT AND COLUMNS FOR CAR AND TENDER TRUCKS.

The accompanying engraving illustrates a design for an improvement in car and tender trucks, which embodies the spring plank, spring seat and columns in a single steel casting. The views shown are in sufficient detail to be readily understood without further explanation as regards the construction. The design is by Mr. Thomas N. Gallagher and the Shickle Harrison and Howard Iron Company, St. Louis, found-

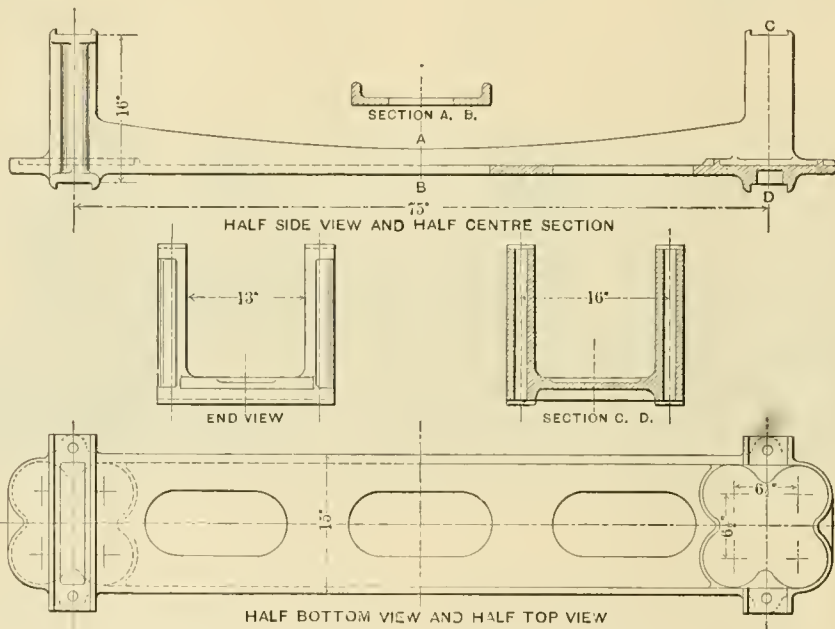

Combination Spring Plank, Spring Seat and Columns.

ers of open hearth steel castings, are the manufacturers.

The advantages urged for this device are a considerable reduction in the number of pieces used in the construction of trucks and a very rigid and substantial construction. A number of these castings have been put into service under tenders and the reports from them indicate that they are very satisfactory in practice. The castings are made for either coil or elliptic springs, the form shown in the engraving being arranged for coil springs. They are made of open hearth steel. The general dimensions are shown, but these are, of course, varied to suit the design of the trucks. We think the reduction in the number of parts composing a truck which this plan offers an important improvement, which will be appreciated, especially by those who have strong preferences for trucks of the arch bar type.

The Union Station in Chicago is to be rebuilt and rearranged at a cost of about \$30,000. The plans have been prepared by Mr. D. H. Burnham, of Chicago, and it is understood that there will be a convenient entrance to the track platforms direct from Adams street, as well as by means of a general entrance on Canal street.

EIGHT-WHEEL PASSENGER LOCOMOTIVES—IMPERIAL GOVERNMENT RAILWAY, JAPAN.

Twenty narrow gauge American type locomotives have been completed by the Brooks Locomotive Works for the Imperial Government Railways of Japan and through the courtesy of the builders we present an illustration of one of the engines, with a table giving the principal dimensions. The whole design more nearly resembles our practice than is usually found in the locomotives for Japanese railroads. The tender is carried on three axles, but otherwise it is like recent American tenders, except the brakes, which are of the vacuum type. The engine has also vacuum driver brakes. The chief dimensions follow:

Description.

Type	eight-wheeled passenger
Name of operating road.....	Imperial Government Railways of Japan
How many and dates of delivery.....	twenty, January, 1898
Gauge	3 feet 6 inches
Simple or compound.....	simple
Kind of fuel to be used.....	bituminous coal
Weight on drivers	50,400 pounds
" on truck wheels	24,100 pounds
" total	74,500 pounds
" tender loaded	52,000 pounds

General Dimensions.

Wheel base, total, of engine	19 feet 4 inches
" driving	7 feet
" total (engine and tender).....	38 feet 9 inches
Length over all, engine	28 feet 3½ inches
Length over all, total engine and tender.....	46 feet 6 inches
Height, center of boiler above rails.....	7 feet 1 inch
Height of stack above rails.....	12 feet 1½ inches
Heating surface, firebox	89.9 square feet
" tubes	965 square feet
" total	1,054.9 square feet
Grate area	15.2 square feet

Wheels and Journals.

Drivers, diameter	54 inches
Drivers, material of centers.....	iron
Truck wheels, diameter	27½ inches
Journals, driving axle, size	6½ by 8 inches
Journals, truck axle, size.....	4½ by 7 inches
Main crank pin, size	4 by 4½ inches

Cylinders.

Cylinders, diameter	15 inches
Piston, stroke	22 inches
Piston rod, diameter.....	27½ inches
Main rod, length center to center.....	5 feet 10 inches
Steam ports, length.....	14 inches
Steam ports, width	13 inches
Exhaust ports, length.....	14 inches
Exhaust ports, width	2½ inches
Bridge, width	13 inches

Valves.

Valves, kind of	Richardson
" greatest travel	6¼ inches
" outside lap	1 inch

	Boiler.	
Boiler, type of	straight top	
" working steam pressure	160 pounds	
" material in barrel	steel	
" thickness of material in barrel	1/2 inch	
" thickness of tube sheet	1/2 inch	
" diameter of barrel	51 inches	
Seams, kind of, horizontal	quadruple riveted	
Seams, kind of, circumferential	double riveted	
Crown sheet stayed with	radial stays	
Dome, diameter	22 inches	

Mr. G. W. Rhodes at Purdue University.

Mr. Godfrey W. Rhodes, Superintendent of Motive Power of the C., B. & Q., delivered an address before the engineering students of Purdue University, on Feb. 19, upon "Experiences in the Motive Power Departments of Railways." Not many men have enjoyed a wider experience than that which has been had by Mr. Rhodes, and



Passenger Locomotives, Imperial Government Railways, Japan.

	Firebox.	
Firebox, type	sloping, over frames	
" width	6 feet 6 inches	
" length	2 feet 5 1/2 inches	
" depth front	50 1/2 inches	
" depth back	51 1/2 inches	
" material	copper	
" thickness of sheets,		
sides, door, 1/2 inch; crown, 1/2 inch; flue sheet, 7/8 and 1/2 inch		
" brick arch	on studs	
" mud ring, width,		
front, 3 1/2 inches; sides, 2 1/2 inches; back, 3 inches		
Water space at top	front, 3 1/2 inches; sides, 5 inches; back, 4 inches	
Grate, kind of	rocking	
Tubes, number	210	
" material	solid drawn brass	
" outside diameter	1 1/4 inches	
Tubes, length over sheets	9 feet 7 1-16 inches	

Other Parts.

Exhaust nozzle, single or double	single
" " variable or permanent	permanent
" diameter	4, 4 1/2, 16, 4 3/4
Netting	wire
Stack, straight or taper	taper

Tender.

Type	6-wheel, rigid pedestal type
Tank, type	sloping, flat top
Tank, capacity for water	2,400 gallons
Coal capacity	5 tons
Kind of material in tank	steel
Thickness of tank sheets	1/4 and 3-16
Type of under-frame	iron
Type of springs	half elliptical
Diameter of wheels	36 inches
Diameter and length of axle journals	4 1/4 by 8 inches
Length of tender over bumper beams	16 feet 2 inches
Length of tank	14 feet 6 inches
Height of tank	7 feet 4 inches
Height of tank, not including collar	48 inches
Height of tank over collar	66 inches
Type of draw gear	front and rear screw couplings and spring buffers

- Engines provided with:
- Three headlights with 8-inch semaphore lens.
- Smith's automatic vacuum brake on all drivers and on tender.
- One Detroit No. 2 double-sight feed lubricator.
- Three-fourths-pint Detroit lubricators on steam chests.
- Two Kunkle 2 1/2-inch safety valves.

CHICAGO AND DENVER TRAIN SERVICE.

The Chicago & Northwestern announces a new 28-hour train between Chicago and Denver, in conjunction with the Union Pacific. The train will leave Chicago at 10 a. m., arriving at Denver at 1:30 the following day. Returning it will leave Denver at 3:30 in the afternoon and arrive in Chicago at 8:50 in the evening of the following day.

The Burlington also announces a fast train, leaving Chicago at 10 a. m., and making the run in 27 hours, or one hour less than the time of the Chicago & Northwestern train.

few have observed more carefully. His lecture, while dealing with incidents, was full of serious suggestions.

He first discussed the fundamental principles which apply in the management of men, and urged the value of painstaking and considerate attention on the part of heads of departments, sketching briefly some of his personal experiences and leading his audience to a broad view of the responsibilities resting upon those who are called to direct the work of others.

The dependence of practice upon the application of correct principles was illustrated by a convincing discussion concerning the defect of a detail of a locomotive, which had long been standard on a leading road, and which, though parts were repeatedly increased in size, could not be held together until the general design was corrected.

He presented in a charming manner the necessity for conducting experimental investigations under conditions of actual service, and illustrated his point by showing a switch lens which, when tested by sunlight, as is often done, was blue, but which when illuminated by the yellow light of a candle quickly became green; also by exhibiting two red glasses which were of entirely different shades under sunlight, but practically the same when illuminated by yellow light, that is under conditions common to practice.

The value of experimental research was illustrated by a brief account of the Burlington Brake Tests, and the modesty with which the speaker referred to the difficulties encountered, and of the far-reaching effect of the results obtained, aroused but slight suspicion in the minds of the student audience that he was the masterful leader in that great work.

EQUIPMENT AND MANUFACTURING NOTES.

The Michigan Central is putting new boilers, to carry 180 pounds steam pressure, on a number of locomotives now having small boilers. The work is being done at the Jackson shops of the road.

The Richmond Locomotive & Machine Works have an order to build two eight-wheel connected locomotives for the Mississippi River & Bonne Terra.

The Schenectady Locomotive Works have an order to build five ten-wheel, compound passenger locomotives for the Minneapolis, St. Paul & Sault Ste. Marie.

The Brooks Locomotive Works have received orders to build two switching engines for the Carnegie Steel Company, Limited, three 10-wheel freight locomotives for the Flint & Pere Marquette, two locomotives for the Mexico, Cuernavaca & Pacific. Six six-wheel switching engines have been completed for the Cleveland, Cincinnati, Chicago & St. Louis, and also twenty eight-wheel locomotives for the Imperial Government Railways. This concern has also completed four locomotives of the six-coupled, side-tank type for the Seoul-Chemulpo Railway, in Korea. These engines have 14 by 22-inch cylinders, 42-inch drivers, 46-inch straight top boilers, 54 by 35-inch fireboxes and are standard gauge. The road runs from Seoul, capital of Korea, to Chemulpo, a distance of 25 miles.

The Baldwin Locomotive Works have received the following orders: Two simple 10-wheel engines for the Mexican National, one switching engine for the Atlantic Coast Line, one four-wheel, narrow gauge switching engine and one standard gauge consolidation engine for the Dora Furnace Company, of Pulaski, Va., two engines for the Gila Valley, Globe & Northern, one inspection locomotive for the Philadelphia & Reading, four six-wheel switching locomotives for the Minneapolis & St. Louis. The Southern Indiana has received the three new passenger engines built by this firm, and they have also completed four locomotives for the Soudan Railway (Egypt), and are building ten 10-wheel locomotives for the St. Louis & San Francisco, four ten-wheel freight engines for the Southern Indiana, nine heavy freight and six heavy fast passenger locomotives for the Philadelphia & Reading. This firm has presented the locomotive "Columbia" to Columbia University, of New York, to be used as a laboratory experimental locomotive.

The Canadian Pacific will build 20 first-class coaches and 10 sleeping cars in its Montreal shops.

The Crossen Manufacturing Company has an order to build 20 tourist cars for the Canadian Pacific.

The Mount Vernon Car Company will build 100 box and 100 fruit express cars for the Mobile & Ohio.

The Wells & French Company have an order for 100 tank cars for the Glucose Sugar Refining Company.

The Lake Superior & Ishpeming has ordered 40 steel cars of 100,000 pounds capacity from the Schoen Pressed Steel Company.

The Bloomsburg Car Company, of Bloomsburg, Pa., will build 100 gondola cars for the Orange Free State Railway Company, of South Africa.

The Milton Car Works, of Milton, Pa., will build 50 tank cars for the Glucose Sugar Refining Company and 10 cars for the S. P. Shetter Company.

The Illinois Car and Equipment Company will build 40 refrigerator cars for the Louisville Packing Company, in which Bettendorf bolsters are specified.

The Harlem & Hollingsworth Company, Wilmington, Del., has received an order from the Baltimore, Chesapeake & Atlantic for three passenger cars.

The Pittsburgh & Lake Erie has placed an order for 100 steel cars with Schoen Pressed Steel Company. These cars are of the Schoen design and are to be self cleaning.

The Chicago, Rock Island & Pacific has ordered from the Rodger Ballast Car Company 25 Standard 60,000-pound capacity ballast cars and one standard distributing car.

The Jackson & Sharp Company is furnishing the Georgia Pine Railway with one 50-foot passenger coach and one combination passenger and mail car of the same length.

The McMyler Manufacturing Company, of Cleveland, has received an order for a \$40,000 car dumping machine, from the Cleveland, Lorain & Wheeling Railway, for erection at Lorain, Ohio.

The Pullman Palace Car Company have orders for the following cars: Twenty passenger cars for the Grand Trunk, 20 tourist cars for the Minneapolis, St. Paul & Sault Ste. Marie, three dining cars for the Pennsylvania.

The International Correspondence Schools, of Scranton, Pa., have just received a fine new car built for them by the Jackson & Sharp Company. It is to be used for the purpose of interesting persons in all parts of the country in the work of the schools.

The Missouri Car and Foundry Company have orders for the following cars: Five hundred coal cars for the Missouri Pacific, 50 cars for Wells, Fargo & Co., 50 cars for the Shreveport & Red River Valley Railroad, 300 box cars and 200 coal cars for the Louisville, Evansville & St. Louis.

The Long & Alstatter Company, of Hamilton, Ohio, are at work upon a heavy steam driver billet shear for the Johnson Company, of Lorain, Ohio. This is the third machine of this type for that company. In our article on another page of this issue, describing the Concord Shops of the Boston & Maine Railroad, will be found a statement concerning several machines furnished by these manufacturers. The machinery for these shops was selected with great care.

The New York Metal Company, makers of the well-known "Cross and Crown" brand of anti-friction metal, and which abolished its New York city offices in 1892, has opened New York headquarters at 42 Dey street, with A. E. Prier in charge. Mr. Prier's service with the company dates back many years, his previous relation being that of chief salesman. The company's plant is located at Fulton, New York. Thos. D. Lewis is general manager, and the business is being pushed very aggressively.

The S. A. Woods Machine Company, of Boston, long and favorably known for their high-grade wood-working machinery, have made an addition to their business in the form of a department for the special work of building machinery for the construction and repair of railroad cars. They have joined interests with the Carse brothers, of Chicago, and will take up the building of car machinery designed by Mr. David B. Carse and O. E. Ahlander, who was formerly chief draftsman and designer for Messrs. Greenlee Brothers & Co., of Chicago. Mr. Carse has an enviable reputation for railroad work, and his opinion with regard to the arrangement of mill machinery is sought after. He is manager of the new department, and Mr. J. B. Carse, his brother, is assistant manager, with headquarters at 64 Wabash avenue, Chicago. Mr. Ahlander is superintendent of the car department at the works of the company in Boston. We are informed that they have fitted out the Consolidated Cattle Car Company's works at Corwith, Ill., and the shops at Middletown and Norwich, for the New York, Ontario & Western, and that they are now engaged in building hollow chisel mortising and high-speed boring machines for the Louisville & Nashville and for the Lake Shore and Michigan Southern roads. A representative of this paper was recently told by a prominent car builder, who was unwilling to have his name mentioned, that this concern furnished the best woodworking machinery to be had.

The Sargent Company, of Chicago, report a very large business in railway supplies during the past few weeks. They inform us that orders for the new Diamond "S" shoe are coming in rapidly. This shoe, it will be remembered, was fully described in our columns in a recent issue. It is manufactured of cast iron, with inserts of expanded steel, giving great friction and long life to the shoe, without injury to the tire. They have made tests on a large number of railroads with uniform satisfaction, the result of which is shown by the large number of orders on their hooks. Mr. W. D. Sargent, the vice-president and general manager of the Sargent Company, has just returned from England and the Continent, where he has been engaged in introducing the Diamond "S" brake shoe. Notwithstanding the proverbial conservatism of foreign railway managers for American inventions, the merits of the shoe are so clear, that several of the railroads in England are already using them, and the prospect for a large extension of this business is most flattering. The Sargent Company have recently published the second volume in their series on the Diamond "S" brake shoe, giving the results of the remarkable tests of this shoe, which were conducted on the brake shoe testing machine at the shops of the Westinghouse Air Brake Company at Wilmerding, Pa. They will be pleased to furnish copies of these pamphlets, together with results of service tests, to railroad men, upon request.

The electric lighting equipment for passenger cars, as furnished by the American Railway Electric Light Company, of 14 Stone street, New York, was described in our issue of June, 1897, page 201. We are now informed by Mr. Wilbur Huntington, president and general manager of the company, that besides the Pullman car "Mabel," now running in regular service on the Pennsylvania Railroad, the private car, No. 503, used by General Manager Loree, of the Pennsylvania lines; the Canadian Pacific sleeper, "Winchester," and a car on the Boston & Albany Railroad, have been equipped with the apparatus, which is reported to be satisfactory to the officers of the roads mentioned.

The Rhode Island Locomotive Works are reported to have filed a petition in insolvency with assets of \$518,000 and liabilities of \$616,700. Mr. Charles H. Wilson is custodian.

The Carpenter Steel Works, of Reading, Pa., have received an order for 27,000 projectiles for the Navy Department. They will range in weight from 480 to 1,080 pounds, and will be made in a hurry.

Twenty all-metal gravity dumping cars, of the Goodwin type, have been leased by the Goodwin Car Company, of 96 Fifth Avenue, New York, for five years, to be used on the new aqueduct for New York city, at Jerome Park.

The order for 32 electric locomotives for the Central London Underground Railroad has been taken by an American firm. The locomotives will weigh about 45 tons, and will have a total of about 800 horse-power in the motors. The trains will have five cars each, making a load of 150 tons, which is slightly heavier (about 10 tons) than the average train on the Manhattan Elevated in New York. The speed will be 15 miles per hour.

The following directors were elected at the recent annual meeting of the Franklin Steel Casting Company, of Franklin, Pa.; C. W. Mackey, Charles Miller, J. W. Rowland, W. J. Bleakley, O. D. Bleakley, D. H. Boulton, W. H. Forbes, H. M. Wilson and Robert M. Calmont.

The Chicago Pneumatic Tool Company, of which Mr. J. W. Duntley is president, have received a cable order for 19 machines, to go to locomotive works in Russia, which ordered twelve machines about eight months ago. This is an example showing the satisfaction given by the machines, and it is specially worthy of note that this order comes from a country in which labor is very cheap. The reception of the machines in Europe is evidence that their work is considered superior to that done by hand.

The ventilation of passenger cars will always be an important matter with the railroads, and one of the probable effects of recent agitation over the sanitation of cars is to direct attention to the subject anew. Among the ways of getting proper ventilation is to use ventilators through the roofs, and for this purpose the "Pancoast Ventilator" has been found very satisfactory. We have seen exceedingly strong indorsement of this device from well-known railroad men, who have tried several other kinds, and the fact that they are used on the new Waldorf-Astoria Hotel, in New York, is a further reason for considering them successful. These ventilators are reported to be absolutely storm and cinder proof, and they admit no dust or dirt. This concern also manufacture round-house ventilators, made of gray or of galvanized iron, which have proved to be very efficient.

The Ingersoll-Sergeant Drill Company, of 26 Cortlandt street, New York, have recently donated one of their latest and best forms of air compressors to Sibley College, on condition that certain experimental investigations relating to the compressing of air be undertaken. The compressor has three cranks, two 7 by 9 inch steam cylinders, two air cylinders, one 12¼ by 9 inches and the other 7¼ by 9 inches; the cylinders are water jacketed, and the compressor is to work to a pressure of 100 pounds on the air side, using steam at 120 pounds pressure. The results of scientific investigations on this compressor at Cornell will be looked for with interest.

D'Amour & Littledale, New York, makers of a sensitive bench drill bearing the firm name, have recently filled orders for firms in Germany, England and other foreign countries.

Mr. Francis Granger, 35 Nassau street, New York, has made several shipments of railroad supplies during the past few weeks to Japan. Among them were shipments of rails, steel beams and other shapes, which is an indication of an increased demand in that country for American goods.

The New York, Philadelphia & Norfolk Railroad has given an order to the Delaware River Iron Shipbuilding and Engine Works for a passenger steamer, for the route between Cape Charles City and Norfolk. She will be named the Cape Charles. The following are the chief dimensions: Length, 230 feet; beam, 41 feet; depth of hold, 15 feet; draft, 9½ feet. The boat will carry 250 passengers and 250 tons of baggage. The engines are triple expansion, with cylinders 14, 32 and 60 inches diameter by 48 inches stroke. The boilers, two in number, are 13 feet in diameter, and will carry 170 pounds pressure.

English capitalists have bought manufacturing properties in this country to a considerable extent, but the purchase of English iron works by American capitalists is not usual, and we are informed by "The Engineering and Mining Journal" that rumors have been prevalent in England that the Dowlais Iron Works in Wales have been bought by an American syndicate. Mr. E. P. Martin, the manager of these works, is now in America, accompanied by Mr. E. Windsor Richards, of the Low Moor Iron Works. He is studying American practice.

The Roberts Safety Water Tube Boiler Company is enjoying a phenomenal run of business and has orders on hand to keep the various plants of the company working night and day for months to come. The company has just shipped from Red Bank four boilers to Moran Bros. Company, Seattle, Washington, which are to be placed in vessels for the Klondike trade. At the Chicago branch, the Marine Iron Works, six boilers, aggregating 1,350 h. p., are being built for Klondike steamers. At the Red Bank works seven boilers, with a total of 1,500 h. p., are building for the Lewis Nixon ship yards, and are to be used in vessels building for the Klondike service, and three other boilers building for the same yard will go to South America.

The Bloomsburg Car Manufacturing Company, of Bloomsburg, Pa., has been awarded the contract to build 100 gondola cars for the Orange Free State Railway, of South Africa. These cars will be equipped with steel frames and steel-tired wheels. Fifteen passenger cars are to be built for the same company. These will have forty-inch, steel-tired wheels and will be similar to an American passenger car, except that they will be smaller. These will be the first cars of this description built in the United States for use in Africa.

The Baldwin Locomotive Works have chartered a steamer to carry twenty-two locomotives to Finland.

William Dinwiddie, the photographer, of Washington, who has been taking a series of views, both scenic and industrial, for the Baltimore and Ohio Railroad, has completed the outdoor work, and is now engaged in making proofs of the eight hundred or more negatives that he secured during the summer and fall. About one-third of this work has been completed, and photographic experts, who have examined it, pronounce it the finest collection of its kind that has ever been taken. One of Mr. Dinwiddie's scenic B. & O. views has received honorable mention in the Salon at the Carnegie photographic exhibit in Pittsburgh.

The special business of the Baltimore & Ohio for the month of January included 47 parties, with a total of 1,321 people. Some idea of the attention that this road is now paying to its passenger traffic may be gained from the fact that during the past 18 months nearly 800 passenger cars received thorough and ordinary repairs, 696 being repainted. Nearly all of the equipment is now "Royal Blue," and most of it is equipped with Pintsch gas, the Pintsch light being used on local as well as through trains.

The Boston Woven Hose Rubber Company has removed its extensive offices and warerooms from 275 Devonshire street to the corner of Atlantic avenue and Congress street, Boston. The change gives a much-needed increase in facilities for the management of the business, permitting of carrying a larger stock of goods and of shipping them more promptly, on account of being nearer the shipping points. The new address of the company is 540 Atlantic avenue, Boston, Mass.

The Magnolia Metal Company several months ago sent out a circular to all of the mills and manufacturers and railroads of the United States and Canada, accompanied by a useful fifteen-inch desk ruler, and, requesting a reply stating whether the recipients were using the products of the company, and if so their experience with them. A very small percentage of concerns so addressed ever make response, and taking the number of replies actually received, giving testimony as to the superiority of Magnolia metal, it has been estimated that at least 100,000 concerns in the United States and Canada are to-day using the metal. Testimonials were received through the mails from 2,827 separate concerns or individuals. This number, being nearly 3,000, is a very encouraging result. These testimonials were received from every part of the United States and Canada and were sent in by railway companies, steamship companies, rolling mills, iron and steel manufacturers of every kind and description, machinists, paper mills, cotton mills, woolen mills, wood-working establishments of all kinds, and practically every class of mechanical industry that can be mentioned. This statement is a very remarkable one and shows the wonderful success that the Magnolia Metal Company has had during the past 10 or 12 years in introducing their metal among the mills, manufacturers, jobbers and dealers of the United States and Canada; and their trade is equally as large in foreign countries. This shows what can be accomplished by having a good article well exploited and thoroughly advertised.

The Walker Company, of Cleveland, Ohio, recently finished the largest direct current generator ever built. It was contracted for by the Brooklyn Heights Railway Company, of Brooklyn, N. Y., and its total weight was about 150 tons, the weight of the armature alone being nearly 50 tons. Orders are now being filled for 20 motors for the Metropolitan West Side Elevated Railroad, of Chicago, for 40 double equipments for the Union Railway of New York, and 100 double equipments, including controllers and motors, for shipment to Dresden, Germany.

Our Directory

OF OFFICIAL CHANGES IN FEBRUARY.

Astoria & Columbia River.—T. H. Curtis has been appointed General Manager, with headquarters at Astoria, Ore.

Atchison, Topeka & Santa Fe.—Mr. E. D. Kenna has been chosen First Vice-President. He was formerly General Solicitor. Mr. Paul Morton, heretofore Third Vice-President, has been chosen Second Vice-President.

Baltimore & Ohio Southwestern.—Mr. James M. Percy has been appointed Master Mechanic, with headquarters at East St. Louis, Mo. He was formerly Master Mechanic of the Cincinnati, Hamilton & Dayton.

Bangor & Aroostook.—Mr. C. S. Nason, formerly Master Mechanic of this road, died at Bangor, Me., January 28.

Bellingham Bay & British Columbia.—Mr. W. McLane has been appointed Master Mechanic, with headquarters at New Whatcom, Wash.

Boston & Maine.—Mr. James A. Corey has been appointed Master Mechanic at Portsmouth, N. H.

Bridgton & Saco River.—Mr. Frederick J. Ilsey has been appointed Chief Engineer.

Buffalo, Attica & Arcade.—Mr. W. W. Bell has been elected Vice-President and Treasurer, with headquarters at Bradford, Pa.

California Eastern.—Mr. D. S. Scofield has been elected First Vice-President and Mr. W. N. Byers Second Vice-President and Treasurer.

Carolina Midland.—Mr. Isaac W. Fowler has been appointed General Manager, with office at Barnwell, S. C.

Central Railway of Guatemala.—Mr. A. C. Michaelis has resigned as General Manager.

Cincinnati, Portsmouth & Virginia.—Mr. W. B. Ruggles, Chief Engineer of this road, has resigned.

Cincinnati Northern.—Mr. Frank B. Drake, General Manager, has resigned and Mr. George L. Bradbury, General Manager of the Lake Erie & Western, will have his jurisdiction extended to carry on Mr. Drake's work.

Charleston & Western Carolina.—The officers of Auditor, E. W. Miller, and General Manager, W. J. Craig, of the Charleston & Western Carolina, which was recently purchased by the Atlantic Coast Line, have been abolished by President H. Walters, of the Atlantic Coast Line.

Cleveland, Akron & Columbus.—Mr. John H. Sample has been appointed General Superintendent, with office at Cleveland, Ohio.

Cornwall Railroad.—At a meeting of this company, held January 25, 1898, Mr. B. H. Buchingham was elected President.

Fitchburg.—At a meeting of the Directors held in Boston, Mass., February 15, Edmund Dwight Codman, heretofore Vice-President, was unanimously elected President.

Fonda, Johnstown & Gloversville.—Mr. J. Lodie Hess has been elected President, with headquarters at Gloversville, N. Y.

Fremont, Elkhorn & Missouri Valley.—Mr. F. M. Marsh has been appointed Chief Engineer, with headquarters at Omaha, Neb., to succeed Mr. J. B. Berry, resigned to go to the Union Pacific.

Great Northern.—Mr. George Dickson, General Foreman of the Locomotive and Car Shops, has been transferred to West Superior, where he takes charge of the company's mechanical department.

Guatemala Central.—Mr. Charles B. Chester, Master Mechanic of this road, died at Chattanooga, Tenn., January 8.

Gulf, Beaumont & Kansas City.—Mr. J. F. Weed has been appointed Chief Engineer, with headquarters at Beaumont, Tex.

Gulf & Interstate.—Mr. James Hickey has been appointed Master Mechanic, with headquarters at Beaumont, Tex.

Interoceanic Railway of Mexico.—Mr. H. E. Walker has been appointed Locomotive Superintendent, to succeed Mr. E. F. Sedgwick, resigned.

Maricopa & Phoenix & Salt River Valley.—Mr. B. F. Porter has been appointed Acting Superintendent, vice General Superintendent C. C. McNeil, resigned.

Mason City & Fort Dodge.—Mr. W. C. Toomey has been elected President.

Minneapolis & St. Louis.—Col. Wm. Crooks having resigned the office of Chief Engineer, that office has been abolished. Reports heretofore made to the Chief Engineer are now made to the General Manager.

Mississippi, Hamburg & Western.—Mr. L. A. Cole has been elected President, succeeding Mr. J. M. Parker, who has been appointed General Manager. Mr. Parker's headquarters are to be at Hamburg, Ark.

Mobile & Ohio.—General James C. Clarke has resigned the Presidency, but, upon the request of the Board of Directors, has consented to serve as a Director of the road.

New Orleans and Northwestern.—Mr. C. G. Vaughn has been appointed Chief Engineer, with headquarters at Natchez, Miss.

Norfolk, Willoughby, Spit & Old Point.—Mr. M. W. Burk has been elected Vice-President.

Omaha Bridge & Terminal.—Mr. John R. Webster has been appointed General Manager. He was formerly Assistant General Manager.

Pennsylvania.—Mr. Samuel Porcher has been appointed Purchasing Agent, to succeed Mr. A. W. Sumner, deceased.

Philadelphia & Reading.—Mr. H. H. Vaughan has been appointed Mechanical Engineer.

Pittsburg & Lake Erie.—Mr. J. M. Schoonmaker has been elected Vice-President and General Manager, Mr. G. M. Beach was appointed Assistant General Manager, and Mr. J. B. Yohe, General Superintendent.

Salt Lake and Ogden.—Mr. James M. Kirk has been appointed Master Mechanic, with headquarters at Salt Lake City, Utah, succeeding Mr. W. T. Godfrey, recently resigned.

San Francisco & North Pacific.—Mr. Andrew Markham has been elected Vice-President succeeding Mr. Philip N. Lillenthal.

Seattle & International.—The following officers have resigned, owing to the sale of that road to the Northern Pacific. Mr. John H. Bryant, President-General Manager; Mr. Charles Powers, Secretary and Treasurer; Mr. C. S. Mellen has been elected President.

St. Paul & Duluth.—L. S. Miller having resigned the office of Assistant General Manager has been abolished, and the duties of that position will hereafter be performed by A. B. Plough, Vice-President and General Manager.

Terre Haute & Peoria.—Mr. James T. Brooks has been elected Vice-President, succeeding Mr. J. J. Parrish.

Texarkana & Fort Smith.—Mr. Charles Snooks has been elected Secretary and General Manager.

Texas Central.—At the annual meeting recently held in Waco, Texas, Richard Oliver, heretofore Secretary, Treasurer and Auditor, was appointed General Manager, Secretary and Treasurer, succeeding Charles Hamilton, who remains as Vice-President.

Union Pacific.—Mr. George H. Pegram, Chief Engineer, has resigned.

Union Pacific.—Mr. John B. Berry has been appointed Chief Engineer, with headquarters at Omaha, Neb., vice Mr. George H. Pegram, resigned.

Waynesburg & Washington.—Mr. Joseph Wood has been elected President, succeeding the late John E. Davidson. Two new Directors were also elected, Mr. Joseph Wood and Edward B. Taylor. Mr. J. J. Brooks was elected Vice-President.

Wheeling & Lake Erie.—Mr. E. X. Hermensader, of Massillon, Ohio, has been appointed Assistant Master Mechanic of the shops at Norwalk, Ohio, succeeding Mr. Bernard McGinn, assigned to other duties.

Wheeling Bridge & Terminal.—Mr. John A. Rutherford has been appointed Vice-President, with office at New York, vice Mr. C. H. Coit, resigned.

Wisconsin Central.—Mr. John A. Whaling has been appointed Purchasing Agent to succeed Mr. A. D. Allibone, resigned. Mr. Whaling occupied this position previous to January 1, 1896.

Wisconsin & Michigan Railway.—The office of General Manager has been abolished and the jurisdiction of Mr. A. H. Crocker, Superintendent, has been extended to cover operation of its ferry line.

AMERICAN ENGINEER CAR BUILDER AND RAILROAD JOURNAL.

APRIL, 1898.

CONTENTS.

ILLUSTRATED ARTICLES:	Page	MISCELLANEOUS ARTICLES:	Page
Concord Shops—Boston & Maine Railroad.....	109	The Railway Signaling Club.....	115
Construction of a Modern Locomotive.....	116	Coal Records of the Wabash.....	125
Chemistry Applied to Railroads.....	119	Engineering Notes.....	128
Improvements in Making Stay-bolts.....	121	Sir Henry Bessemer.....	131
Wheel Wear as affected by Side Bearings.....	123	A. M. Watt at Purdue.....	133
Locomotive Design Strength of Materials.....	121	Fires in Naval Vessels.....	135
Steam Motor Cars, The Baldwin Locomotive Works.....	135	The Coffin Toughening Process.....	139
Locomotives—Grand Trunk Railway.....	136	The "Peerless" Hose Specifications.....	119
Ten-Wheel Locomotives—Boston & Maine Railroad.....	137	Big Gun for Sandy Hook.....	111
Hunt Coal Cracker.....	137	Advantages of Steel Cars.....	141
Baldwin Locomotives for the Soudan.....	138	Equipment and Manufacturing Notes.....	141
Brooks Locomotives for Korea.....	139	EDITORIALS:	
Axle Lighting on the Santa Fe.....	140	Lack of good draftsmen.....	126
Armstrong Pipe Machine.....	111	Locomotive Design.....	126
		Improved Facilities in Shops.....	126
		Electric Cranes vs. Transfer Tables.....	126
		Rubber Hose Specifications.....	127
		Electric Power in Shops.....	127

CONCORD SHOPS—BOSTON & MAINE RAILROAD.

Descriptions of this plant were begun in our February issue, page 37, and continued in the March issue, page 73. They are published simultaneously in the "American Engineer" and the "Railroad Gazette" by special arrangement.

Boiler Plant.

The boiler house is 65 by 50 feet in size and situated as shown in the inset accompanying the first article on the shops. (See our February issue). One roof covers the boiler and power house, the two being separated by a brick wall through which the steam mains pass. There are three locomotive type radial stay boilers with spaces for two more and an ashpit for a fourth when it shall be needed. The boilers are 70 inches in diameter in the barrel, and are built for a working pressure of 180 pounds. The smokebox end is supported upon a swinging link and the fire box end stands over a bricked-up pit. The boiler room has a cement floor and the pits under the boilers are arranged to admit small iron dumping carts under the fireboxes to receive the ashes. The pits are shown in section in the plan view of the boiler room. The space under the front portion of the boilers is excavated to a depth of four feet and a five-foot trench passes from this excavation under the north wall of the building for removing the ashes by means of a hoist that raises and loads them upon cars. The excavation is large enough for a week's accumulation of ashes. At the boiler fronts a space of 17 feet 10 inches is provided and in this a trestle is built for running coal cars directly into the boiler house and delivering the coal at the furnace doors.

The boilers each have a total heating surface of 1,834 square feet, the grate area is 40 square feet, and the tubes are 14 feet long. They connect to transverse breeching, which leads to a 70-foot stack. The smoke passes through an induced draft smoke fan driven by a direct connected engine, and its bearings are cooled by a circulation of water. The boilers are fed by two seven and a half by five by six-inch duplex outside plunger, brass fitted Deane (Holyoke) pumps, each of which is capable of feeding all of the boilers. Water is taken either from the "700 H. P." Cochrane feed water heater situated in the corner of the boiler room as shown in the plan or it may be taken from the city mains. This feed water heater takes the exhaust from the engines in the power plant and a direct ex-

haust discharge is provided to the roof for use if necessary. The heater was furnished by the Harrison Safety Boiler Works, Germantown Junction, Philadelphia. The condensation water for the whole heating piping system, except from the heaters themselves, is returned to the brick hot well or tank, which is shown in the plan of the boiler room. From here it is pumped through the feed water heater and into the boilers. This tank also receives the drainage from the engine receiver jackets and the exhaust pipes and the water circulating through the smoke fan bearings. The smoke fan is supported upon a platform framed by old rails, and it connects the breeching with the stack, causing an induced draft. Its arrangement is shown in the photograph, which also shows the large exhaust pipe and at the left a vapor pipe from the hot water tank to the roof is seen. This fan is six feet in diameter, and is driven by a five by four-inch double engine. It is rated for 750 horse-power boiler capacity.

From the steel nozzles at the front of the dome of each boiler connection is made to the 12-inch header by means of two six-inch wrought iron bends, with angle valves and a short piece of straight pipe between them as shown in the engraving of the boiler connections. The 12-inch steam header runs along the east side of the brick partition wall and is about 65 feet in length, blank Ts being provided for the attachment of two more boilers. From both ends of this boiler room header short upright 10-inch pipes connect with 8-inch mains running westward along the north and south walls of the engine and dynamo room, or "power house," as it is designated on the inset already referred to. In the power house two six-inch cross-over pipes connect these engine mains, and these, together with the mains, form a loop, and as the engines take steam from the cross-over connections it is evident that the mains are practically in duplicate. There is a rise from the boilers and two more between the boiler header and the engines, but to guard against any possible chance for water to reach the cylinders separators are placed between the six-inch cross pipes and the engine throttles.

Power House.

In the power house are two tandem compound "Fitchburg" 200 horse-power engines, a 100 horse-power simple "Standard" Westinghouse and a 125 horse-power Armington and Sims engine, an 8 by 12 Rand duplex air compressor, two 150 kilowatt Westinghouse Electric and Manufacturing Co.'s generators, with exciters, a 50 arc light (Weston) and a 35 arc light (Weston) dynamo, and considerable space is provided for future additions to the plant. This is also provided for in the steam piping. The plan view of the power house gives the location of the machinery; the plan view of the piping shows the arrangement of the mains, the separators and valves and the arrangement of the exhaust piping from the Fitchburg and Westinghouse engines leading under the floor to the feed water heater in the boiler room is shown in a separate drawing. The exhaust from the engines joins in passing to the heater, and an out-of-door exhaust is provided, whereby the heater may be cut out. This piping is carried in trenches large enough for a man to work in and covered by sectional cast iron plates made for easy removal. The exhaust from the air compressor and the Armington and Sims engine is carried to the planing mill heater, or it may be discharged through the roof during warm weather. The steam piping in the power house, with the exception of the cross-over connections, is given a slope of 1-16 inch in 12 inches, in the direction of the steam current. The cross-overs are two feet six inches above the north and south mains and are level. The north and south mains are 13 feet above the floor. There are no expansion joints in this system. The piping is hung from the roof trusses by roller hangers, and all of the piping and fittings are made extra heavy, with a view of a possible future increase in the working steam pressure. All of the fittings and valves above four inches in diameter are flanged, the flanges being grooved with tool marks to hold the packing, which is

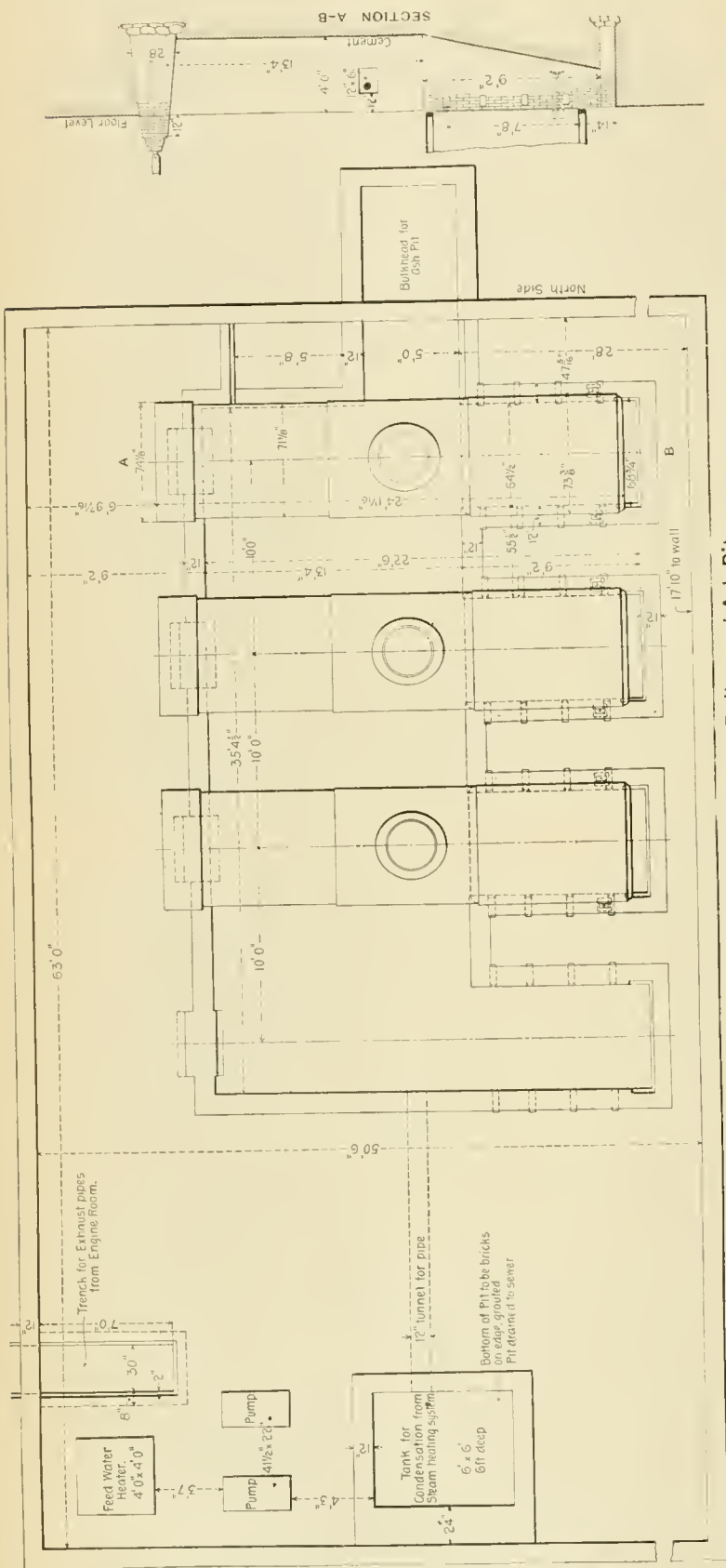

Plan of Boiler House Showing Boilers and Ash Pit.

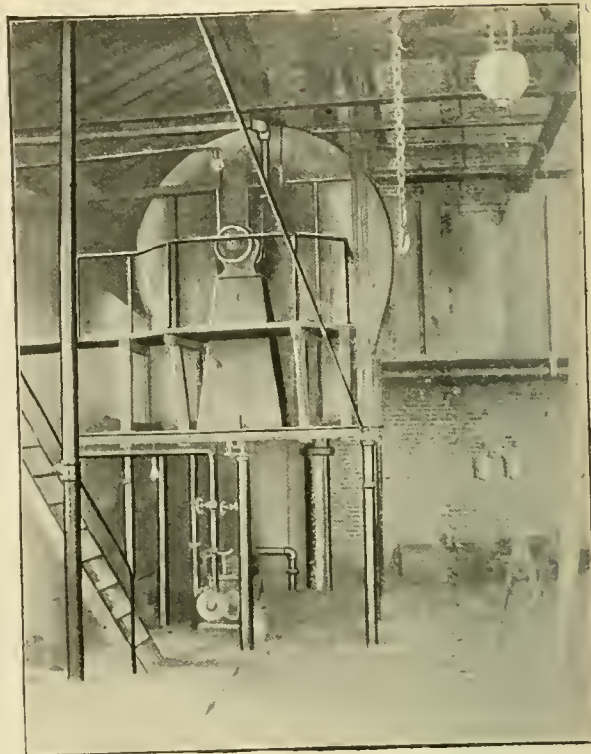

Smoke Fan Located over Steam Pumps in Boiler House.

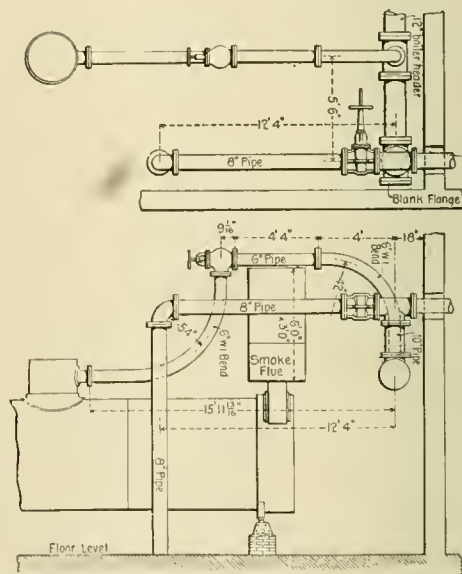

Connections from Boilers to Header.

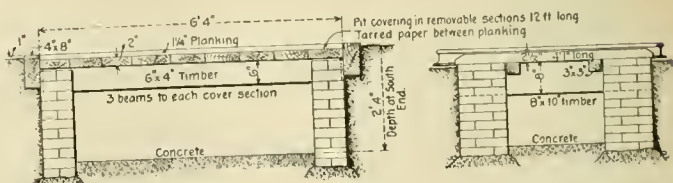

At Power House.

At Blacksmith Shop and Store House.

Sections of Steam Pipe Trenches.

of the "Rainbow" brand, manufactured by the Peerless Rubber Manufacturing Co., throughout the plant. The exhaust pipes through the roof are provided with exhaust heads, of which there are three, one twelve-inch, one seven-inch and one six-inch.

The engines furnished by the Fitchburg Steam Engine Co., of Fitchburg, Mass., are of the tandem non-condensing compound type, with automatic cut-off and four valves. They have girder frames. The high pressure cylinders are 13 inches and the low pressure 22 inches in diameter, the stroke being 30 inches. They run at a speed of 125 revolutions per minute, taking steam from a four-inch pipe and exhausting into an eight-inch pipe. The fly wheels are 11 feet in diameter and have 31-inch faces, each taking a 26-inch belt for the generators and a three-inch belt for the excitors. The main bearings are 7½ inches in diameter by 16 inches long, and are filled with Babbitt metal and have adjustable side boxes to take up wear. The crank and crosshead pins, piston and valve rods are of steel, the connecting rods are of scrap iron, with hard bronze bearings for the crank and crosshead pins. The valves are of the balanced, expansible piston type, with positive adjustment of diameter to take up all wear that may occur during the life of the engines. The steam valves are double-ported and are actuated by a wrist plate cam motion, giving good regulation under the most abrupt changes of load. The exhaust valves are at the bottom of the cylinders, draining all water, and they are operated by an independent eccentric, giving free opening without altering the compression at the end of the stroke with changes of load. The engine bed is very heavy, and the crosshead shoes have a large area. Each engine has a steam jacketed receiver, connected between the cylinders. The engines are to regulate within 1½ per cent. from no load to full rated load and vice versa, no matter how abrupt the change in load may be.

The 100 horse-power Westinghouse engine is used to run the arc light dynamos, both of which run at a speed of 820 revolutions per minute. Its location and the connections for steam and exhaust are shown in the engravings. The 125 horse-power Armington and Sims engine, located in the northwest corner of the power house, runs the planing mill, as was explained in the second article. It is thought that one electrician with two assistants, one engineer and one fireman for day work and one for night will be able to operate and care for the power plant, and this does not increase the force above the number of men formerly employed for the purpose in the old shop plant, which was a very much smaller one.

The air compressor was furnished by the Rand Drill Co. It is an 8 by 12 inch duplex "Class B" steam air compressor, and is so designed as to permit of disconnecting either air cylinder if desired. The main frames are of the Corliss type, and are bolted to the cylinders by means of strong studs and faced nuts. No Babbitt metal is used about the machine, the pistons are solid and fitted with snap rings. The air cylinders are jacketed for cooling water, which is conveyed by pipe to the hot water reservoir in the boiler room for use as feed water for the boilers. The compressor has the Meyer adjustable cut-off valves, and it is regulated to a pressure of 100 pounds of air by a pressure governor. The fly wheel is solid and weighs 2,000 pounds. The weight of the complete machine is 6,500 pounds, it is 12 feet 5 inches long, and four feet eight inches wide, its capacity is 195 cubic feet of free air per minute, pumped against a pressure of 100 pounds.

Generators.

Besides the two arc light machines there are two generators in the power house supplying power for the motors. These are wired so that power and incandescent lamps may take current from both or one may run the lights, while the other operates the motors. The latter arrangement is necessary, owing to the dimming of the lamps while raising a heavy locomotive on the cranes if the lamp and motor circuits are combined. These generators furnish power for all of the mo-

tors enumerated further on in this description. They were furnished by the Westinghouse Electric and Manufacturing Co., each with a capacity of 150 kilowatts at 440 volts. They are of the two phase alternating type, the construction being shown in the engraving. Each alternating dynamo has a 5.62 kilowatt field exciter driven at a speed of 1,400 revolutions per minute by a narrow belt from the engine belt wheel. The electric plant includes one No. 2, a No. 6, a No. 8, a No. 12, two No. 16 and two No. 100 converters. The electric crane circuits are wired for a maximum of 200 amperes at 440 volts, the transfer table takes 60 amperes at 440 volts and all of the other motor circuits are 440 volts each. The incandescent lighting at the shops is done by a 440 volt current transformed to 104 volts, while that at the Concord station and in the Young Men's Christian Association building, about a half mile from the shops, is transformed from 440 to 1,000 and then down to 104 volts. Besides about 30 arc lights at the passenger station and others in the yards, these are used in the erecting, machine and boiler shops, the blacksmith shop and all of the buildings except the lumber shed, dry house and paint store house. The arc lights are spaced 50 feet apart for inside and from 150 to 200 feet apart for outside lighting. There are about 450 incandescent lamps at the station, freight house and round house, and about 300 in the various shop buildings.

The general appearance of the generators furnished by the Westinghouse Electric and Manufacturing Co. is shown by the accompanying illustration. The lower half of the field casting and the supports of the bearings constitute a single casting, insuring accurate centering of the armature. The field poles are of soft laminated steel, cast into the field yoke or frame. The magnetic circuit is of ample section to prevent saturation. The bearings are self-aligning and self-lubricating and the bearing surfaces are unusually large. A special grade of soft steel is used in building up the armature core, and the methods of construction avoid injury to the steel, which would increase losses due to magnetization. The armature coils lie in slots and are held therein by means of retaining wedges of hard fibre, driven into notches near the top of the slots, longitudinally with the armature. No band wires are used and both core and winding are thoroughly ventilated. The field and armature coils are wound upon moulds or formers and thoroughly insulated before they are put in place. Machines of this type operate at moderate speeds, which is a feature of great practical value.

The switchboard has an iron frame, supporting five marble panels, with indicating and switching devices for the dynamos. The transmission of the currents for lights and motors is over a wire system strung on a pole line through the shop grounds.

Motors.

The shop motors are the Tesla Polyphase Induction type, furnished by the Westinghouse Electric and Manufacturing Co., running on 400 volt, two phase currents, with 7,200 alternations. The distribution of the motors is as follows: One 30 horse-power on the east side and one 20 horse-power on the west side of the locomotive shop, one 20 horse-power motor on the large bending rolls in the boiler shop, one 15 horse power motor in the blacksmith shop to drive the fans, one 20 horse-power in the same shop to drive the machinery, one 5 horse-power motor in the small shop buildings, besides the crane and transfer table motors.

The alternating current motor is specially well adapted to this kind of work, and the type used in this installation is worthy of study by those who are soon to be called upon to equip railroad shops with electric transmission. The interest which is taken at this time in electric motors demands a rather complete description, the information for which is furnished by the manufacturers.

The form of the motor is shown in the illustration. It will be noted that from a mechanical standpoint, this motor is reduced to the simplest possible elements, i. e., a stationary part permanently connected to the main circuits, and a rotating

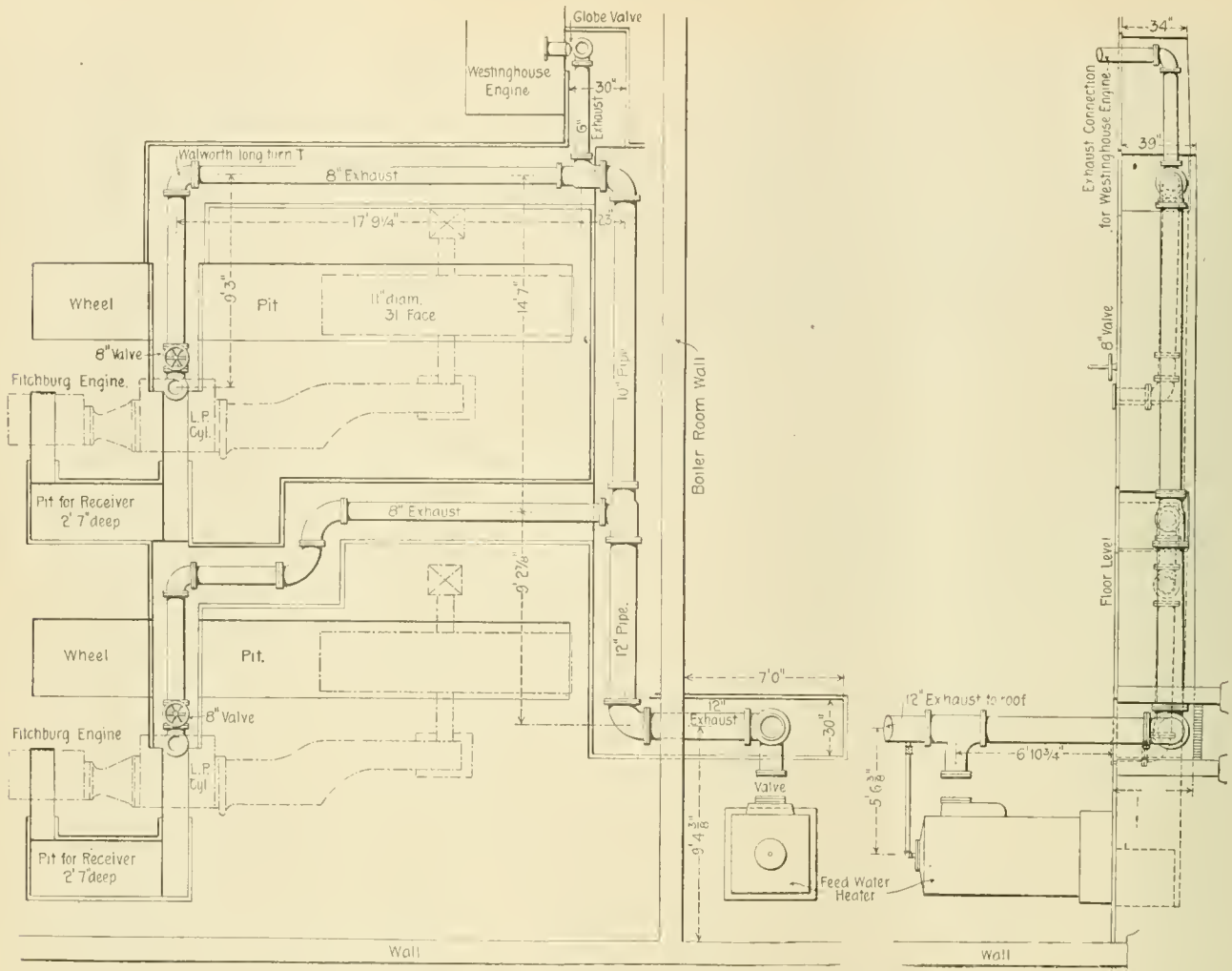

Concord Shops—Plan of Exhaust Piping in Power House.

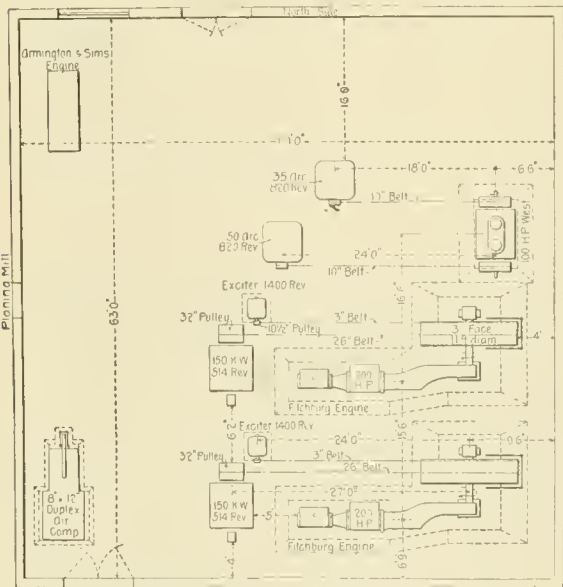

Engine and Dynamo Locations.

part having no electrical connection with any other, and absolutely no electrical contacts or adjustments; in fact, no sliding or working friction except that of the shaft in the journals. The only parts that can wear, therefore, are the shaft and journal boxes. The friction in these is very slight, on account of the light weight of the rotating part. Ample self-oiling bearings provide for liberal lubrication. It will, therefore, be

observed that as a piece of moving machinery, the motor is designed and built to operate for long periods of time with but a very small amount of attention. These are known as "Type C" motors.

The hollow cylindrical frame of cast iron, in which the primary is mounted, forms a base for the machine and also supports the two end brackets carrying the self-oiling bearings. Perforated iron plates fitted into these brackets, both protect the rotating element and permit excellent ventilation. They may be replaced by solid plates when it is desired to make the motor absolutely dust-proof. It will be noted that the housing completely encloses the primary and secondary elements and protects them from any external damage.

The primary element consists of a hollow cylinder built up of laminated sheet iron rings, slotted on the inside to receive the conductors. These rings are rigidly supported by the cast iron housing which encloses the primary. The conductors are machine wound coils, which are thoroughly insulated before being placed on the core. The terminal blocks which are located on top of the machine are connected to the primary winding by leads which pass through the housing.

The design and principles governing the construction of the type "C" motor are fortunately favorable to the maintaining of a high and almost constant efficiency from full load to one-half load. Under the conditions which prevail in a very large proportion of electric motor service the motors are operated much of the time at considerably less than their full rated capacities. With this motor, therefore, by maintaining a constant efficiency, it is possible to secure an all day or average efficiency very much above that heretofore possible, with either direct or alternating current motors. The variation of speed between no load and full load is small, being less than that

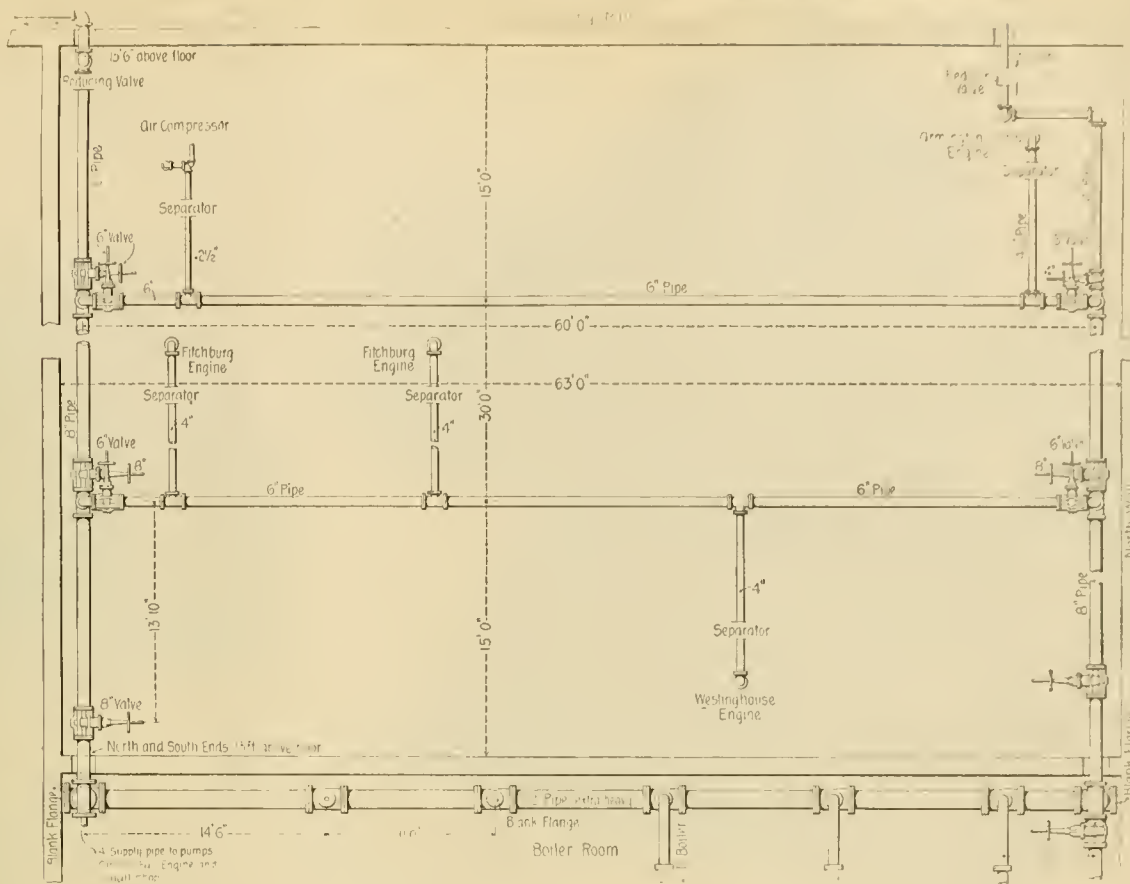

Concord Shops—Plan of Steam Piping in Power House.

found in direct current motor practice, as determined by exhaustive tests.

A polyphase induction motor may be started by connecting it directly to the circuit with an ordinary switch. Small motors are so started in practice. The larger motors are started on a reduced voltage, the full E. M. F. of the circuit not being applied until the motors have reached a considerable speed. The fact that in a four-wire two-phase circuit different E. M. F.s exist between different pairs of wires, affords an easy way of obtaining the necessary reduction in E. M. F. For some classes of two phase and for three phase service the reduction of voltage is effected by a device called an auto-converter. This device is entirely separate from the motor itself. It is possible, by the use of the auto-starting device, to adjust a motor after installation to have any desired starting torque within very wide limits. Thus, a motor operating machinery having great inertia may be made to give a correspondingly strong starting torque, while one driving a very light device may be adjusted for extremely small starting torque, with a corresponding reduction in starting current.

The alternating current crane motors are provided with a regulator, illustrated by one of the cuts, by which the pressure of the current is varied. The control of the motor is somewhat similar to the control of a variable speed engine by the throttle, which reduces the steam pressure delivered to the engine, thus enabling its speed to be varied at will over a wide range. The motor receives from the regulator a pressure varying from a small amount up to the maximum for which the motor is adapted. This variation gives a starting torque which has a maximum value equal to about four times the torque which the motor can develop at high speed continuously. The motor has a certain maximum speed which it does not exceed, even though the full pressure be applied and there be no load. This is of very considerable practical importance in assuring that no accident will occur through the abnormally high speed which might otherwise result if the load be sud-

denly thrown off. The regulator provides a wide range of adjustment by small steps, so that practically any torque at any speed can be obtained over a very wide range.

The regulator consists of a special form of transformer by which the voltage is efficiently reduced. A number of terminals are brought out from the transformers which are carried to the regulator, so that the pressure from the various contacts can be successively applied to the motor. The crane motors are exactly similar in construction, operation and simplicity to the constant speed motors. The difference between the constant speed and variable speed motors is in certain details of construction. Three or four wires are all that are required between the circuit and regulator and also between the regulator and the motor.

Steam Heating System.

The large shop buildings are all heated by the fan system, while the store house has ordinary steam radiators. The fan equipments were furnished by the Boston Blower Co., and are all alike, except as to the heaters, which vary in size in accordance with the sizes of the buildings. A description of one of them will, therefore, answer for all. It should be noted that there are two heaters in the locomotive shop, offering the advantage of closer regulation of the heating in moderate weather than would be possible to obtain with a single large heater.

Each of the locomotive shop heaters has 22 sections, each having 80 eight-foot pipes and giving a radiating surface of 14,740 lineal feet of one-inch pipe. The blower is the Boston steel plate exhauster with full housing. The height of the fan is about 10 feet, the fan wheel is 72 inches in diameter by 34 inches wide at the periphery, and 42 inches wide over all. The inlet has a diameter of 50 inches, while the outlet is 44 by 40 inches. The housing is of heavy steel plate, braced with T and angle iron. The fan is directly connected to a seven by seven-inch engine, as usual in this system of heating. The steam manifolds are subdivided and piped so that either live

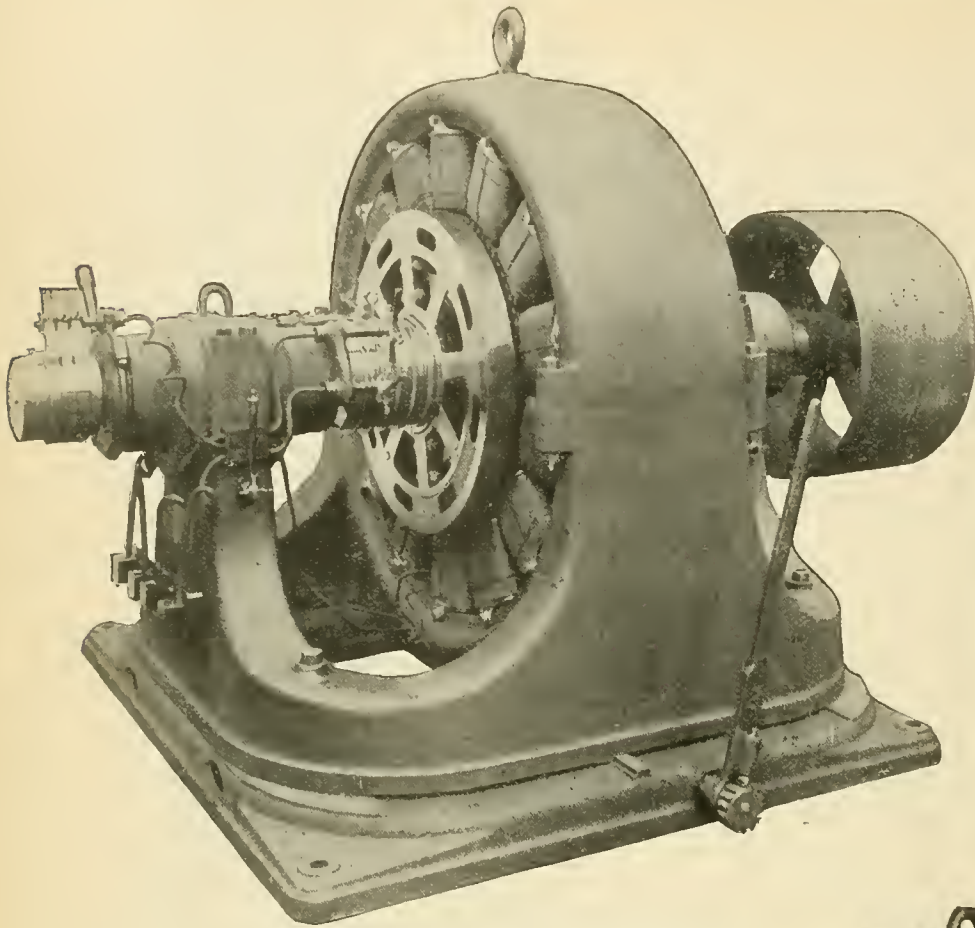

Belt-Driven Alternating Current Generator.

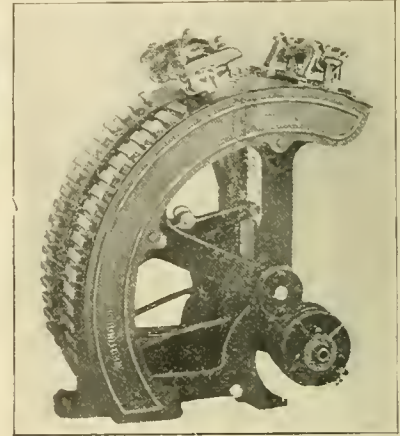

Regulator for Crane Motors.

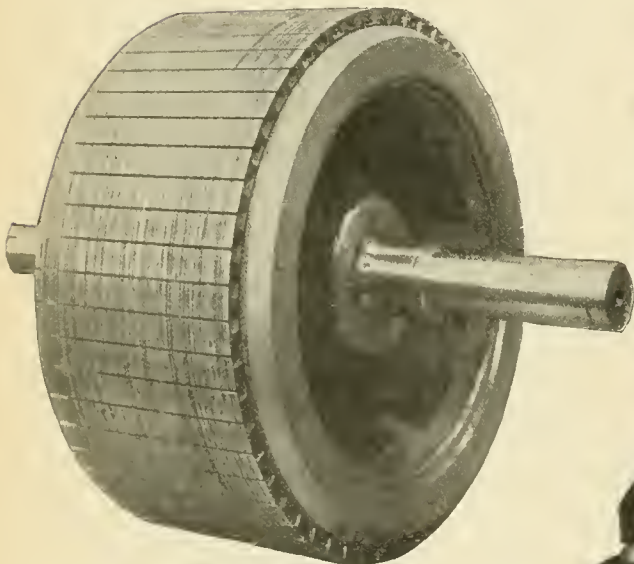

Armature of Motor.

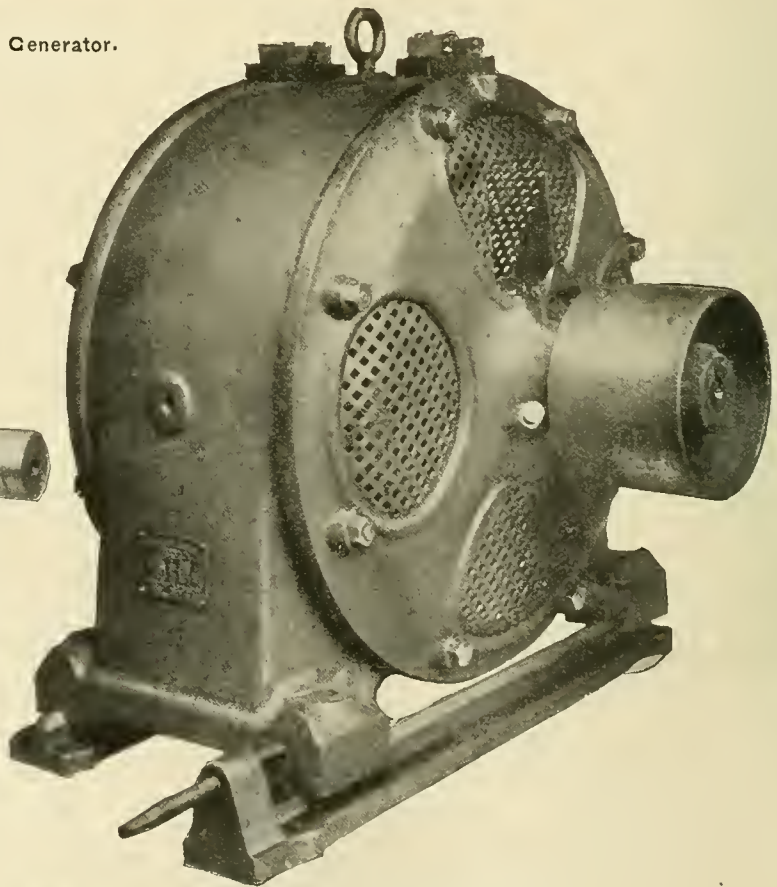

Tesla Polyphase Induction Motor.

CONCORD SHOPS—BOSTON & MAINE RAILROAD.

Electrical Machinery by THE WESTINGHOUSE ELECTRIC AND MANUFACTURING COMPANY.

or exhaust steam may be used in the several sections of the heaters.

To reach the heaters in the different shops an extensive system of underground steam and return piping was necessary. This system is conducted through trenches of ample size, all of which are given pronounced slopes for drainage not only of the pipes, but of the trenches themselves. They are provided with concrete floors, brick side walls and plank covers. The heating pipes extend north from the power house a distance of 780 feet and south 890 feet. They carry a pressure of 30 pounds per square inch. All of the condensation, except that from the heaters themselves, is returned to the boiler house hot water tank. The steam piping was put in by Messrs. Isaac Coffin & Co., of Boston.

By returning to the plan of the piping in the power house and also to the large general plan of the shops and grounds (see our February issue), the arrangement of the steam piping will be understood. The north eight-inch main in the power house extends through the planing mill wall and supplies the planing mill heater and the dry house radiator coils. From the south eight-inch main a six-inch extension runs south through the planing mill and at the extreme south end of the mill it passes underground through a brick trench to the car repair shops, entering that building on the east side of the partition wall between the freight and passenger car shops. It serves the heaters in these shops and passes on to the paint shop, as indicated in the large plan. Each heater has a separate trap, the drainage being discharged into the sewers. Only one expansion joint was used in this line, it being necessary to put one in the long straight run in the planing mill. A two and a half-inch pipe reduced to a two-inch and one and a half-inch is run along under the large pipe for use in heating water and glue during warm weather.

The steam pipes running north connect with the north header in the boiler room and pass directly down and into the trench, which is marked "conduit" in the large plan view (see inset with February issue). This conduit is two feet four inches deep at the power house and is four feet nine inches deep at the locomotive shop, a good slope for a distance of 378 feet. A six-inch pipe runs through the north trench and it makes two turns in order to avoid expansion joints. The main changes from six inches to five inches at the blacksmith shop connection. Traps are located at the wall of the locomotive shop and also at the extreme end of the line at the heaters. For anchorages large stones were buried, each about four feet square and one foot thick, care being taken to provide side bracing along the pipe line to hold its alignment. The pitch of the pipes was a little greater than that called for in the specification, viz.: 1-16-inch in 12 inches. An expansion joint was found necessary in the long straight run in the locomotive shop. Nason steam traps are used throughout on the steam piping, except one trap for the 12-inch boiler heater. The traps, except one, are all arranged to discharge either into the sewer or the hot well system, as desired. The "Rainbow" packing was used throughout the plant for flange joints as being undoubtedly the best for the purpose.

Special care was taken in regard to protecting these long lines of pipe from condensation, "Magnesia Sectional Covering" being furnished for the entire steam piping system, both for power and heating purposes, requiring nearly 4,500 linear feet of pipe covering of varying diameters. Of this nearly 800 feet was for six-inch pipe. This was all furnished by Messrs. Keasbey & Mattison Co., of Ambler, Pa., and as a very large number of valves, Ts, crosses and other fittings were also covered, the order was a large one.

In closing this description it should be stated that the work was all carefully planned beforehand and every part of the installation was carried out according to the drawings. This included the piping, and it is stated that the plans were not changed at all during the progress of the work. Some comments would be in order here but for the lack of space.

We desire to acknowledge the courtesies of Mr. Henry Bart-

lett, superintendent of motive power, Mr. J. T. Chamberlain, master car builder, Mr. C. H. Wiggin, master mechanic at Concord, and Mr. G. E. Mitchell, chief draftsman of the motive power department, for information and other assistance in preparing these articles.

On page 76 of our March issue, in giving the names of concerns having furnished machinery for the Concord shops of the Boston & Maine Railroad, we inadvertently gave the address of the Putnam Machine Co. as Worcester, Mass., when it should have been Fitchburg, Mass. This firm is so well known that the error will hardly be noticed, but we regret that it was not stated correctly.

THE RAILWAY SIGNALING CLUB.

The March meeting of this club was called to order at the Duquesne Club, Pittsburg, March 8, Mr. W. H. Elliott, vice-president, in the chair, and 30 members present.

The paper of the day, entitled "The Operation and Maintenance of a Block System on a Single Track Railroad, as Used on the C., N. O. & T. P. R. R.," written by Mr. W. A. D. Short, was read and discussed. The principal points brought out in the paper and discussion were:

Questioning rule 4, which requires that "Trains of an inferior right approaching a meeting point within the limits of a block, may pass the red signal and proceed to the siding when under full control." By decision of the majority of the members, it was stated that signals should be re-located so that this rule would not be required, it being a bad plan to have trains run by a signal, under any circumstances, when at danger.

The point in regard to the rule requiring the engineer to observe the signal change to danger before he passed it was fully discussed. The sense of the meeting in this regard was, that with the automatic signals in use to-day, this was an unnecessary precaution and that full confidence should be placed in the proper working of the signals; that the disadvantages of requiring the engineer to stop balanced the protection to be afforded by his using caution in going through the block, so that it was very doubtful if there was not more danger in taking the indication as a danger signal in place of the clear signal.

The use of lead-covered copper signal circuit wires for burying in the ground was, from the experience of the members, thought to be very unsatisfactory, owing to the eating away of the lead from the chemical action of acids in cinders in certain soils.

A discussion in regard to insulated joints brought out a very favorable opinion of the members in regard to the excellent service to be obtained from the Weber joint.

The protection of electric street railway crossings of steam railroads was taken up and informally discussed. The general opinion seemed to be that a complete interlocking was necessary for efficient protection; that the device in use at Cleveland and some few other places, where the conductor was required to go ahead and by pulling a lever and close a derailling switch would allow the car to go over the crossing, was a very poor one, as there was no certainty that the conductor would use ordinary caution and assure himself that there was no train approaching; that although this might relieve the steam railroad of any responsibility should an accident occur, still the fact was that the accident would not be prevented, as would have been the case had a complete interlocking been put in.

In the evening a complimentary banquet tendered by Mr. E. H. Goodman of the Union Switch & Signal Company, was held at the Duquesne Club, and it was very enjoyable.

Arrangements were perfected by which the Pennsylvania Railroad would put a train at the disposal of the club on Wednesday, by which trips would be made to the Carnegie plant at Homestead, the Westinghouse Air Brake Works at Wilmerding, the Westinghouse Electric Works at East Pittsburg and the Union Switch & Signal Co.'s works at Swissvale.

It is reported, upon what appears to be satisfactory authority, that the Wagner cars will displace those of the Pullman Company on the Union Pacific, and undoubtedly the service will be greatly improved by the change.

THE CONSTRUCTION OF A MODERN LOCOMOTIVE.*
II.

By Motive Power.

The amount of material carried on hand at any one time should, as far as possible, be about equal to the amount of output for the same period of time, and in works managed in that way it will be necessary in connection with new orders to arrange for the arrival of material and its ordering in connection with the capacity of the department in which that material is to be used, and orders in the general office for material specified on the lists are made accordingly. All orders for work of whatsoever kind, with the one exception to which we will refer later should be issued from the general office, and

MODERN LOCOMOTIVE COMPANY.
Work Order.

Date.....189.. No.....

From Supt's Office | Charge to Work Order No.....

To

To Furnish:

Drawing No.	Wanted.
Delivered to	For
Completed	Cost

Material Order Cards Issued:

When Completed, Card Must be Promptly Sent to Office of Supt

Fig. 4.

the detail of their issue and their manipulation be sufficiently simple to entail the minimum of expense and clerical labor, and a maximum amount of accuracy, as matters of record. For this purpose two distinct forms have been found sufficient and satisfactory, one known as the "work order" form and illustrated in Fig. 4, and the second one as a "material order" form and illustrated in Fig. 5. A third form, illustrated in Fig. 6, is also issued from the accounting department for the purpose of keeping record of the time or labor expended on any particular job.

For the purpose of giving a charge, as well as the authority to do certain work, a work order form is issued from the general office, having been filled out in the proper spaces indicating the number of the order to which the work is to be charged, giving a description of the work, the drawing number and such other information as would answer to intelligently guide the head of the department to which the order is sent in getting out the work specified.

number is also marked on the list corresponding to and having the same number placed on the order card referred to. This list in the hands of the head of the department to which the order was sent becomes a guide for that department as to the quantity and kind of material which they will require and can draw from the storehouse.

MODERN LOCOMOTIVE COMPANY.
Material order.

Date.....189.... No.....

From Supt's Office, | Work order No.....

To

Required:

Drawing No.		Wanted.		Charge to	
Date.	No. of pieces.	Kind of material.	Weight or quality.	Price.	Received.

When completed, card must be promptly sent to Keeper of Stores.

Fig. 5.

At the same time the work order referred to is issued an additional form of the same kind is filled out and sent with it, but having a separate number for each department to which it may be sent, in contradistinction to the case of the other form, which has the same number for all departments in which any work may have been done. This second card is termed a "spoiled work order" and to it is charged all of the work which may be spoiled during the construction of that particular job. There being a different number on each one of these spoiled work orders for each shop, the amount of spoiled work on any one particular order is thus identified with the shop in which it has been spoiled.

In case there is a shortage of material required, owing to omission on the list or owing to spoiled work or smaller parts being lost or found defective, the material order card illustrated in Fig. 5 can be issued bearing the same work order number above referred to and specifying the kind and quantity of material required. This card can only be issued by the general office and after notification from the shops or storehouse of the shortage and the reason why. A record is kept in the

MODERN LOCOMOTIVE COMPANY.

No.....

.....Shop. Time Card.189..

No. of pieces.	Description of parts,	Contract card number.	Operation.	Work order.	Commenced.		Finished.		Hours.		Rate.	Money.
					Date.	Time.	Date.	Time.	Day-work.	Piece-work.		

Names of men in Gang.	Piece-work hours.	Rate.	Money.	Correct:

..... Foreman.

Fig. 6.

For the ordinary run of regular output this card is accompanied by a complete list of the material required for that work, made out in and verified by the drawing room. Copies of this list are also sent to the keeper of stores, and it becomes for him a warrant from the general office for the delivery of the material for that particular order number. The order

general office of the issue of the work order cards referred to, and also the issue of the extra material orders, and an entry is made in this record as well as on the face of the material order indicating the reason why extra material was required. At the completion of the order the lists which have been issued for the job, as well as the material orders for extra material or the replacement of defective or spoiled material, are returned

*For previous article see page 79.

to the general office by the keeper of stores and these must check with the original record of their entry.

It will be noted that on the work order cards a space is provided to indicate the shop or department to which that particular division of the work is to be sent. On the lists also are indicated in the proper columns the various shops or departments in which the various parts are constructed.

For convenience and brevity the various shops or departments may be indicated by initial numbers or symbols. It is also convenient to indicate the course of works by a succession of shop initials placed in the order in which the various stages of the work to be performed, on the card, for instance:—"S," "M" and "E" would indicate that the smith shop

MODERN LOCOMOTIVE COMPANY,
Annual Work Order Material Card.

From.....
To 189

Description of Material.	Wt. or Quantity.	Price per Unit.

Charged to Annual Work Order No.
Foreman.

Fig. 7.

had performed the first operation on that particular piece, and it should be sent next to the machine shop for that operation, and follow from there to the erecting shop for the last operation. Various modifications of this will naturally suggest themselves, governed by peculiar conditions of the facilities of the plant.

There is no reason why the larger percentage of the work done in the shop should not be on a piece work, or practically a form of contract system, and for the purpose of keeping track of the amount of time and the separate jobs detailed to the men, the foreman is provided with a contract card, which he issues to the man or men who are going to perform the work, and which bears on its face a designation of the particular job, the contract price and other necessary information. A record of this card is kept in the foreman's office, and

A clear and concise knowledge of the expenditures for repairs to tools and machinery, buildings and the various other facilities may be so arranged that the total of these expenses, forming as they do a portion of the expense charges, can be determined for each separate department at the end of each month, if desired, and becomes one of the essentials of proper and economical management. For the purpose of determining this as many divisions of this kind of expense may be made as are deemed advisable or would properly suit the peculiarities of the plant, and for the purpose of saving unnecessary clerical labor this may be governed by the issue of a work order card for each of these divisions, bearing a separate number for each and a separate number for each shop, specifying what it is desired to include under that particular order number. For instance:—The repairs and extensions made to any one particular shop building during that year or the repairs and extensions made to the tools and equipment included in that one building during the year may be so handled. All work performed and material used may be charged to this number and arrangements made for condensed monthly reports of the returns of such expense made to the accounting department.

It has been found convenient as a system of management to consider each department as a separate and distinct enterprise of its kind, against which are charged the expense for wages, material consumed in repairs of building, tools, etc., cost of ordinary shop supplies, material consumed in manufactured output by that particular department, and also a proportion of the fixed charges for superintendence, office expenses, etc., crediting that department with the value of its output; and in most cases, following it in this way, it will be found that all of the elements necessary for detecting defective management, unnecessary extravagance, and for increasing the economical efficiency of this department, can be determined.

There is no reason that we know of why each department should not be made to pay its own expenses, and frequently it becomes purely and simply a question of improved facilities to be used in preference to the facilities then in service.

For reasons which have been found exceedingly satisfactory in connection with repairs and additions to tools and machinery, or to buildings or the various other equipment of the plant, the judgment of the foreman of each department gov-

MODERN LOCOMOTIVE COMPANY.
Record of stock received and consumed.

Sec.	Bin.	Location.	Description.	Order number.	Date.	Quantity.	Furnished by	Quantity rec'd.	When received.	How received	Price per unit.	Cost of freight.	Total cost.	Bill number.	Month charged.	Freight weight.	F. O. B.	January.			February.			March.																
																		Total rec'd.	Quantity consumed.	Quantity on hand.	Total rec'd.	Quantity consumed.	Quantity on hand.	Total rec'd.	Quantity consumed.	Quantity on hand.														

Fig. 8.—(About 45 lines).

each card is given a number. These numbers are entered by the men on their time or service cards (illustrated in Fig. 6) under the proper heading. Where wages are paid by the month these cards should be recalled to the foreman's office on or about the end of the month and the man given credit for that proportion of the job which he may have finished up to that time, in case the job is not completed. This proportion is arrived at by the judgment of the foreman, and it will be obvious that, as very few jobs take more than a month, or, at the very outside, two months, the man will receive the balance in the next succeeding pay. A form of this card is illustrated in Fig. 10.

erns the amount of repairs made to the equipment in his department, including its building or buildings, and for the purpose of getting the necessary material, which is usually carried in stock for that purpose, he issues from and keeps record in his office a special form of material order, shown in Fig. 7. This form should specify the kind and amount of material required and the yearly work order number for which that material is to be used. They are kept by the keeper of stores, the price of that material put on them, and sent by him to the accounting department.

As will be more thoroughly explained below, these cards are also issued for drawing the regular run of shop supplies,

small tools, etc., which are constantly required and are kept in stock in the storehouse. It has in some cases been found convenient to include this line of supplies under the general heading of "Repairs and additions to tools and machinery."

We desire to impress on the mind of the reader more partic-

important questions connected with proper management of the plant. The records should be clear, concise, free of unnecessary repetition and complete in detail, and a daily record of material received and monthly record of material consumed, showing proper balances, etc., should be kept on one set of

MODERN LOCOMOTIVE COMPANY.
Stock Record.

Section.....
Bin No..... Class No

Date.	Order No.	Quantity.	Furnished by.	Quantity rec'd.	When rec'd.	How rec'd.	Price per unit.	Freight.	Total cost.	Bill No.	Month charged.	Freight weight.	F. O. B.	Total rec'd.	Total consumed.	Total on hand.

Fig. 9.-(About 12 lines.)

ularly the flexibility of this scheme than its being confined to any particular division, and that various and possibly more convenient divisions of these yearly orders covering the expenditure which would be included in expenses may be made to suit peculiar cases. The time expended in using material for the yearly work order in that particular department is entered on the time form shown in Fig. 6, using the yearly work order number for its identification.

The confidence in the foreman indicated in this has been sufficient protection against extravagance or the unnecessary expenditure of money in repairs to equipment and buildings,

MODERN LOCOMOTIVE COMPANY.
Contract Order Card.

From

To 189..

Enter on each card items chargeable to one account only.

Charge to work order.....Completed 189..

Fig. 10.

and a comparison of the monthly reports giving these expenses affords a check against any unnecessary and excessive increase.

As already indicated, the various employees working by the hour throughout the plant enter up their own time on the form shown in Fig. 6, and each one of these forms must be carefully scrutinized by the foreman of that department in which the men are employed and be signed by him, after which they are returned to the accounting department, from which department they have been originally issued. These forms are issued in sufficient numbers daily for the requirements of the plant, and each one of them having a number corresponding to the assigned number of the employee who is to use that particular card.

All of the stock of material kept in the storehouse may be divided into departments for convenience of location and handling, and where bins or convenient shelving are provided the amount of stock placed in these bins or removed from them, from time to time, may be entered on a card prepared for the purpose and kept in a convenient pocket in the bin. The entries on these cards should only be made by one man in the storehouse to insure greater accuracy, and this constitutes a daily record of the consumption of that kind of material. At the end of each month the amount consumed, as indicated by these cards, may be entered in the receiving and stock book.

The care, handling and record of raw material received or distributed, in this case by the storehouse, is one of the most

blanks, either bound in book form or kept on cards. For reasons which will be explained, we consider the card system to have great advantage over the book form. If bound in the book form there should be enough pages to cover a period of three months, which will make the book less bulky, and provide for a quarterly stock-taking or check on the condition of stock of raw material on hand. One of the pages of this form of stock-book is illustrated in Fig. 8. It will be obvious that this form has one principal objection, that the various items will have to be kept in alphabetical order, and, owing to its bound form, spaces must be left anticipating additional shipments of the same kind of material during the three-month period that the book remains open. This is more or less uncertain, and it provides for an excessive amount of waste space, and for other reasons has its objections. It is true, however, that the combination of what would practically be a receiving book with a stock-book has an advantage which two separate books would not have. Its bulk, however, and the practical impossibility of grouping together similar kinds of material for the purpose of condensed information, would make its adoption in some cases impracticable.

Fig. 9 illustrates a form of card used in what we will term the "card system" of keeping stock record, and this avoids the objections raised against the book form. The rulings, divisions and headings are practically the same as that illustrated in Fig. 8, except that enough lines can be provided on one of these cards to cover a period of six months or a year, or less, if desired. In the use of these cards it is intended that each item of stock shall have its own classification, and be indicated

MODERN LOCOMOTIVE COMPANY.
Credit Work Order No

From.....

To 189..

Description of Material.	Wt. or Quantity.	Price per Unit.

Wt. or Quantity and Price per Unit to be Added by Keeper of Stores. Foreman.

Fig. 11.

by a number. This number will be placed on the upper right hand corner of the card, and as many cards may have this number as would be necessary to provide proper room for entries of that one kind of material. This will make it unnecessary to have the cards any larger than would be convenient for handling. The section letter of the storehouse and the bin number in which the material is stored are entered in the upper left hand corner, and the intervening space filled in

with a description of that particular kind of stock. At the end of each month the total of that stock received is entered under the proper column, also the total of the stock consumed and the total on hand, and the transaction for that month practically closed on the card, the date of receipt of the material indicating the portions of the month or termination of the month or the beginning of the next succeeding month. Any special forms of calculation in connection with the stock or material entered on the face of these cards, or memorandums relating to it can very properly be made on the back of the card, where they remain as an individual record. These cards may be kept in a case divided up into as many compartments as would be required, and kinds or groupings of material kept by themselves. They are more available for quick consultation than the book form, and have an advantage over the book form in that similar kinds of material may be grouped to any desirable extent. This method of keeping stock has many other advantages which will be apparent to the reader, without going into further details.

It will be obvious that the column headed "Month Charged," while not necessary for use in all cases, will be required in certain special cases which would have a more or less direct bearing on the carrying out of the system of costs and expenses in the accounting department, and in this connection we consider that, as far as the general question of raw material is concerned, the most important questions connected with it are, to buy well, use well and quickly transform it into the finished product at the minimum cost. With a reliable system in the storehouse of receiving, caring for and dealing out of the raw material, an ordinary form of merchandise account in the accounting department should be ample in connection with this phase of the question.

Without going into the detail of what the various subdivisions would include, the general headings "Total Expense for Raw Material," "Total Expenses of Operation," which would include all wages, interest and other details properly included under "Expenses," "Total Value of Output" and "Excess" or "Stock Shortage" at the end of the year are the vital figures to be arrived at.

We have referred to a system of credits for excess material which may have been specified on the lists, owing to the fact that the exact amount could not be determined. A special form provided for this purpose, printed in red ink, is illustrated in Fig. 11, and is to be used at the completion of an order by the various departments in which work has been done on that order. It will have inserted on it the amount and kind of material in excess of that specified on the lists as necessary and also the work order number on which the balance of that material was used, indicating at the same time the work order which should have credit for that excess of material. These cards are sent to the general office and the proper credits or corrections made on the original lists. They are then sent to the keeper of stores, who will make the necessary credits in his stock of that kind of material, put the prices of that material on these cards, and they will then go to the accounting department. It should not be necessary to repeat this operation on succeeding orders for a similar class of engine, for the reason that a proper return of these credits once will definitely decide the amount of material to be used on the succeeding orders of engines.

Independent of the material which we have referred to above as being ordered for a certain order of engines, there is a large amount of material which is consumed by the shops themselves in connection with their maintenance and operation, coming under the heading of small tools, belting, and a variety of such supplies, and these may be drawn directly from the storehouse on a form of material card issued by the foreman of the department where the material is required and are charged directly to that department and order number. It is convenient to arrange, and have it so understood with the various departments, that the supplies which they require shall be drawn at or about the same period each month, and at that time they shall endeavor, as far as possible, to draw enough supplies to cover one month's necessities. This will periodically reduce very greatly the stock on hand of this kind of material and make it less troublesome to check up at the end of each month not only the stock remaining on hand, but to arrive at the amount of material required for the next ensuing month, it being considered good policy to only purchase this class of material in quantities equal to about its consumption per month.

(To be continued.)

CONTRIBUTIONS TO PRACTICAL RAILROAD INFORMATION.

Chemistry Applied to Railroads.—Second Series.—Chemical Methods.

XXIII.—Method of Testing Spirits of Turpentine.

By C. B. Dudley, Chemist, and F. N. Pease, Asst. Chemist, of the Pennsylvania Railroad.

Explanatory.

As is well known, spirits of turpentine, so largely used as a constituent of paints, japans, and varnishes, is a distillate from certain species of pine, or from the pitch from these pines. The common adulteration in the markets of this country appears to be petroleum in some form, although it is quite possible that rosin spirits, or the undistilled pitch, or even rosin, may be added. It is not expected that the tests that are described below will insure that nothing but pure spirits of turpentine is present in the sample examined, or in other words, that none of the sophistications above mentioned, or indeed others not enumerated, may not be present in small amount. It is believed, however, that a material that successfully passes these tests will give satisfactory results in actual use, either as a constituent of paint, japan or varnish. During an experience of over five years with these tests, using them on

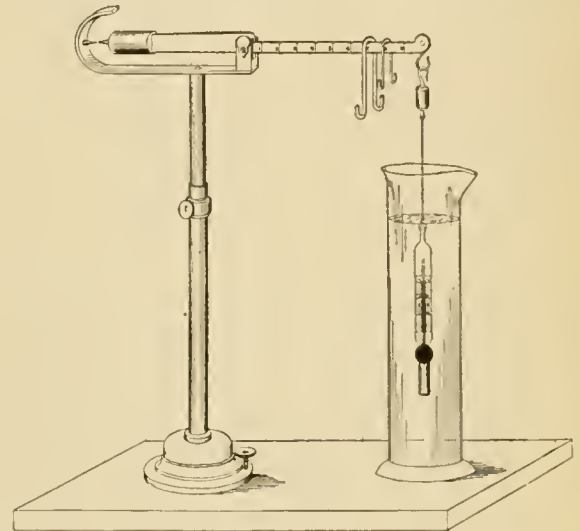

The Westphal Balance.

ten to fifteen shipments a month, very few complaints have arisen, notwithstanding the shipments are used by a large number of different painters. The tests which are applied to each sample representing a shipment, are gravity, distillation point, residue on evaporation and treatment with oil of vitriol. The methods are described in detail below.

Gravity.

The specifications require that the sample shall not show a gravity less than 0.862 at a temperature of 59 degrees Fahrenheit. In taking the gravity of this material, the Westphal balance is always used, as follows: Set up the balance on a level place, by placing the beam in position and hanging the plummet on the hook provided for it. Now adjust with the adjusting screw in the foot until the pointers are exactly opposite each other, cool the liquid to be tested to a point a little lower than that required by the specification, fill the jar with enough of the liquid, to a little more than cover the plummet, and place the jar in position. Allow the temperature of the liquid to rise with occasional stirring, until the reading of the thermometer in the plummet is that required by the specifications. Now hang the weights on the beam at the notches provided for them, until the pointers are again exactly opposite each other. If two belong on the same notch, hang the second on the hook of the first. Read the marks on the beam

where the weights hang, and set down the figures by the side of each other, putting the figure under the heaviest weight at the left hand, that under the next heaviest, next, and so on. The result will be the specific gravity expressed in decimals.

The Westphal balance shown in the cut is usually now constructed with a plummet weighing five grams and occupying the space of five cubic centimeters. This is called Reimann's Patent Thermometer Body. The beam is graduated into equal divisions, and the heaviest weight weighs five grams. The next size weight weighs a tenth of this, the next a hundredth and the smallest a thousandth. The balance being adjusted in air, so that the pointers are exactly opposite, if the plummet is immersed in distilled water at 15 degrees C., the heaviest weight being placed on the hook with the plummet should bring the pointers opposite each other again.

Rosin, pitch and probably rosin spirits, if present, would increase the gravity, while the colorless petroleum products available for admixture would diminish it. Absolutely pure, properly prepared spirits of turpentine, is claimed to have a gravity of 0.864. In order to allow a slight margin on this figure, the limit of the specifications was placed at 0.862, no upper limit being assigned, as the other tests applied, are believed to exclude material too heavy in gravity. Furthermore, the gravity of pure spirits of turpentine increases with the age of the sample, so that an upper limit of gravity, made close enough to exclude small percentages of rosin spirit, for example, might be troublesome when examining a sample of pure spirits of turpentine, which, owing to the exigencies of the market, had been stored a little longer than usual. It is obvious that the gravity test only protects against admixture of substances lighter than 0.862 in gravity. The mass of shipments show a gravity of from 0.866 to 0.872.

Distillation Point.

The distillation point is taken in a 500 c.c. round-bottom distillation flask, provided with a side neck. This side neck is usually made of $\frac{1}{4}$ inch glass tubing, and is 7 or 8 inches long. In order that the danger of igniting the vapor driven off during the process may be diminished, the side neck is introduced into a small Liebig condenser, which condenser also serves by this arrangement to support the flask. The condenser is set at such an angle that the flask hangs perpendicularly. A chemical thermometer, with the graduation on an enameled scale, and enclosed in a glass tube, is inserted in the flask, to within half an inch of the surface of the liquid, being held in position by a cork through which it passes and which closes the flask at the top. The apparatus being arranged, about 100 c.c. of the spirits of turpentine are poured into the flask, and the thermometer put in place. Then, with a Bunsen burner held in the hand, with the flame about four inches long, heat is applied directly to the bottom of the flask, care being taken to distribute the heat by playing the flame, so that the whole bottom is heated slowly and evenly. Vapor soon begins to rise from the surface, which is visible. Also the thermometer begins to show the heat. The heating should be so managed that by the time the liquid boils, the visible vapor surrounds the thermometer up to the side opening, or begins to pass out through the side opening. To accomplish this it may be necessary to withdraw the lamp from time to time to allow the heat to distribute, and the thermometer to adapt itself to the temperature. By the time the boiling point is reached the thermometer, if the sample is pure spirits of turpentine, should show not lower than 305 degrees Fahrenheit. The boiling may be continued from five to ten seconds, during which time, if the heating has been properly managed, the thermometer will stand fairly constant. As the boiling is continued the thermometer slowly rises in temperature. The fairly constant reading during the first few seconds of boiling is what is taken as representing the distillation point of the sample. It is given in the authorities that pure spirits of turpentine boils at 313 degrees Fahrenheit. Some years ago a number of

samples of American turpentine, believed to be pure, were tested in the manner described above, and some of them found to give figures a little lower than this. Accordingly, the lower limit of acceptable material was placed at 305 degrees Fahrenheit. The mass of our tests run about 307 or 308 degrees Fahrenheit, the average barometric pressure being about 29 inches of mercury.

Obviously, this test simply excludes any admixture of materials of low boiling point, such as low boiling point petroleum, or low boiling point volatile oils.

It may seem a little hazardous to apply the naked flame to a glass flask containing so inflammable a substance as spirits of turpentine. But after an experience of several years, the first accident from breaking a flask from this cause has yet to be recorded. The spirits of turpentine seems to take the heat readily, and the whole operation is free from bumping, unless perchance water be present in drops. Care should, therefore, be taken in putting the sample into the flask, that no drops of water are added. In selecting a thermometer, one should be chosen which is so graduated that the limiting figures will be only just above the cork, or, better still, just below the cork inside the flask. It will, of course, be recognized that unless the whole column of mercury is immersed in the hot vapor, the indications of the thermometer will be a trifle low.

Residue on Evaporation.

Spirits of turpentine, as is well known, is volatile at temperatures much below its boiling point, while rosin, pitch and indeed some of the petroleum products which may be used as admixtures do not so vaporize. The residue left on evaporation is therefore a valuable test for this material. The specifications do not admit material containing over 2 per cent. of residue. The test is made as follows: Weigh a platinum capsule holding out 100 c. c. and then add 20 grams of the sample to be tested, excluding drops of water, should any be present. Evaporate to constant weight over a water bath, or other convenient source of heat, not exceeding in temperature 250 degrees Fahrenheit. The increase in weight of the dish multiplied by 100 and the product divided by 20 gives the percentage of the residue. The material left in the dish is usually hard and brittle like rosin, and commonly reddish in color. Occasionally it is viscous, somewhat like pitch.

It is entirely possible that some of the residue found did not originally exist in the spirits of turpentine, but may have been formed during the process of evaporation. This point has not been carefully investigated to our knowledge. Whatever the case, there is very little difficulty in obtaining in the market spirits of turpentine which meets the requirements of the specification in this respect. By far the largest number of shipments do not show over 1 per cent. of residue. Very old material, however, is apt to run high in residue, and it not infrequently happens that an adulterated sample shows four or 5 per cent.

The temperature employed if the sample is pure seems to make very little difference in the result. Comparative tests on pure samples using water bath and a steam table whose temperature is 280 degrees Fahrenheit give practically the same results. The wording of the specifications requires the evaporation to be done at 212 degrees Fahrenheit, and in case of dispute this should always be used.

Treatment with Oil of Vitriol.

By far the largest part of pure spirits of turpentine polymerizes when treated with concentrated oil of vitriol, the polymerized portion dissolving in the acid. The same thing is true in part of rosin spirit and of some other substances which may be mixed with turpentine, but it is not true of the petroleum products, nor to any great extent of rosin oil. This gives a means, therefore, of determining the presence of some substances which may be present, and which are not revealed by the other tests. The specification excludes samples containing more than six per cent. of unpolymerized material. The

method of applying this test is as follows: Into a 30 cubic centimeter tube, graduated to tenths, put six cubic centimeters of the spirits of turpentine to be examined. Hold the tube under the spigot, and then slowly fill it nearly to the top of the graduation with concentrated oil of vitriol. Allow the whole mass to become cool and then cork the tube, and mix by causing the material to flow from one end of the tube to the other five or six times, cooling with water during the operation, if necessary. Set the tube vertical, and allow it to stand at the ordinary temperature of the room, not less than half an hour. The unpolymerized material rises to the top, and the amount may be easily read off. This multiplied by 100, and divided by six, the original amount taken, gives the percentage.

The oil of vitriol used must be full strength, or the polymerization will not be complete. It is best to use the C. P. material. The amount of heat generated by the action of the oil of vitriol on the spirits of turpentine is considerable. Usually much of the reaction has taken place by the time the acid is all added, but care should be taken to cool as described before putting in the cork and mixing. Otherwise the cork may be blown out, and the test lost. There is always some clear layer of unpolymerized material in every sample even the purest. This with a pure material is probably principally cymene. Most samples do not show over 3 per cent. of clear layer. If petroleum is present, the layer is limpid and clear. If partially polymerized turpentine is present, the layer is more viscous and frequently colored.

If the reading of the layer is taken before half an hour has elapsed, the unpolymerized material often has not all separated. On the other hand, if the time of standing is prolonged considerably, the material is apt to divide into three layers, making the reading difficult and uncertain. With pure material and reading at the end of half an hour there is very little doubt.

RECENT IMPROVEMENTS IN MAKING STAYBOLTS.

Test holes for giving warning of partially broken stay bolts have been used for a number of years. No one now doubts the necessity of providing in this way against the danger of partially broken bolts, and the present tendency is toward using test holes in all short stays, instead of in a few only, as was formerly considered sufficient. The holes were formerly always drilled with the bolts in place and headed over, but it is now necessary to reduce the cost, since more are used, which has led to the punching of the holes when the bolts are made. We show how this is done, and also the effects upon the bolts.

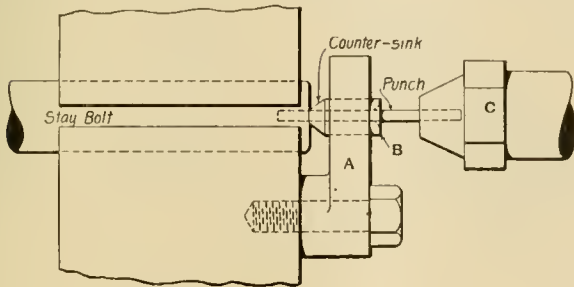

Fig. 1.

Another improvement in stay bolts is in the threading, and we show the method devised and developed by Mr. James Hartness for cutting the threads accurately in a turret lathe by means of dies.

Punching Test Holes.

A method used on the Chicago, Burlington & Quincy Railroad is shown in Fig. 1, the punching being done on a Blakeslee bolt header. The hot stay bolt is held in the clamps of the machine. A piece, A, is bolted to one of the clamps and is bored out to receive the cylindrical piece, B, which is a neat fit in the piece A, and yet sufficiently loose to slide in and out when pres-

sure is brought to bear on it. The piece B is bored to allow the punch to pass through it and it is slightly bell-mouthed at its outer end to aid the punch in entering. This furnishes a guide to keep the alignment of the punch. The inner end of the piece B is tapered as shown, and it is so placed in relation to the plunger C as to cause the plunger to come into contact with it when the plunger still lacks about one-eighth of an inch from the end of its stroke. The plunger then forces the tapered end of the piece B into the end of the staybolt, counter-sinking the hole made by the punch. The object of this is to prevent the hole from being filled up when the staybolt is riveted over. The scheme will be readily understood from the engraving.

The etchings shown in Figs. 4 and 5 were kindly furnished by Mr. Wm. Forsyth, Mechanical Engineer of the C., B. & Q. R. R., and they were taken to ascertain the effect of the punching and the turning down of staybolts upon the fiber of the material.

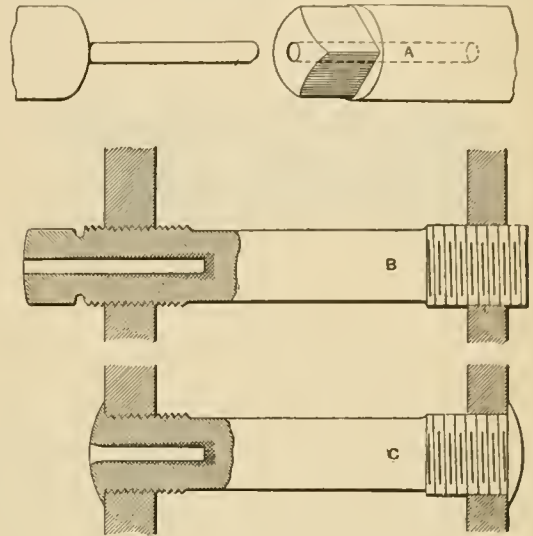

Fig. 2.

The bolts were screwed into the sheets of the fire box in the usual way and were headed over by the boiler maker's hammer. They were then sawed off just inside the sheets and were planed and etched. From an examination of the etchings it appears that there is little or no distortion of the fibres when staybolts turned down to a diameter of 11-16 inch at the center, and also that the hot punching of a 1/8-inch hole to the usual depth does not injure or distort the fiber.

The Baldwin Locomotive Works are punching all of their stay bolts on a bolt machine. It has been suggested that such a process improves the quality of the metal at the end by solidifying it, but the Baldwin people make no such claim, although they have satisfied themselves by severe tests that bolts so treated are fully equal to those drilled after the usual method. Their process as shown in Fig. 2 has been patented by Messrs.

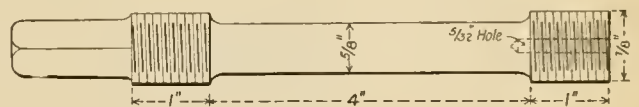

Fig. 3.

Johnson and Lukens. In this illustration A, is a perspective view of a stay bolt showing the punch. A view partly in section is shown at B, with the bolt after it is placed in position in the boiler and before it is cut off and riveted. A bolt is shown at C, after it is finished in the boiler. The square end of the bolt is made in order to turn it readily in screwing it into the sheets of the fire box. The bolt is held by the clamps of the machine and the punch enters the end after the square end is formed and when the bolt is removed from the machine it is ready to be threaded and turned down between the threads in accordance with the practice of these builders. After the bolt is in position in the boiler the square head is cut off and the ends riveted over, after which a tapered mandrel is introduced into the hole to flare the outer end as shown at C. No metal is removed by this process, hence the bolts are not weakened, the metal is merely

displaced by the punch and the end must necessarily be denser than before.

A plan similar to these was used by Mr. William Buchanan, Superintendent of Motive Power of the New York Central, but we are informed that the practice has been discontinued in favor of drilling. For the punching he used a punch driven by a cam on a shaft. The bolt was held by jaws operated by a hand lever and opened automatically by a spring, an adjusting

enough to cause breakage in a short time. The diameter must be correct and the taps and threading dies should exactly correspond. It is due to Mr. James Hartness, Manager of the Jones & Lamson Machine Company of Springfield, Vt., that all this has been worked out and so simplified as to make it possible to turn and thread stay bolts on a turret lathe. The method was described by Mr. Hartness in two papers presented at the last meeting of the American Society of Mechanical Engineers in New York.

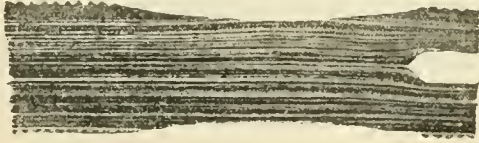

Fig. 4.

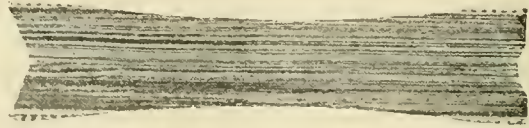
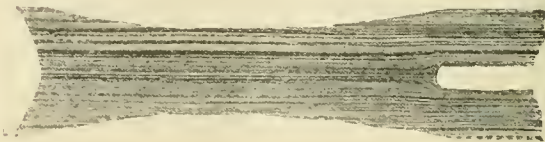
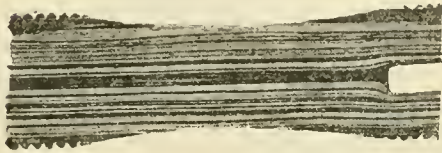

Fig. 5.



screw regulated the depth of the hole. With this machine 1,250 bolts were punched per day.

Mr. Wm. A. Foster, Superintendent of Machinery of the Fall Brook Railway, has found it desirable to reduce the diameter of stay bolts between their threaded ends, but instead of turning them down he draws them out under the hammer and considers the results much superior to those from similar bolts turned down. The form used is shown in Fig. 3. The threaded ends are one inch long and a six-inch bolt would be drawn down through a portion four inches long at its center, the diameter being $\frac{5}{8}$ -inch. The test hole is drilled 5-32 or $\frac{1}{8}$ -inch in diameter and a little more than an inch in depth. The

The bolts are turned from a bar. Tandem dies are used; they are held in position to turn continuous threads and they are made to open so that the front end of the bolt may pass through the first die without being cut. The tap may be used to fix the two dies in correct position, but Mr. Hartness' idea is to make the bolts correctly and the taps can be made to suit. It is clear that if the two dies can be made to cut parts of a continuous, accurate pitch thread, that shall have the same and the correct diameter the problem is solved.

The system of chasers used by Mr. Hartness is an improvement in screw cutting that is worthy of note. It is illustrated in the accompanying engraving. The chasers are held by a cam

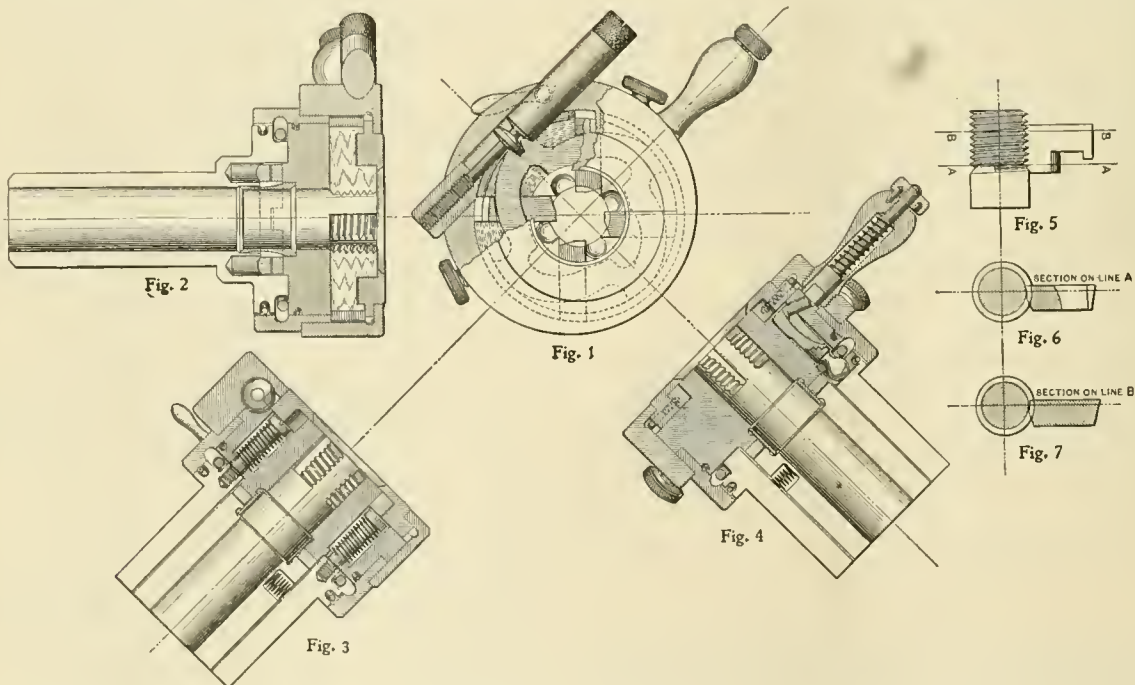

The Hartness System of Dies.

threads are cut on a bolt cutter arranged so as to cut the threads correctly.

Improvements in Threading.

It is of the first importance that the threads at the ends of stay bolts should be accurate, and that they should form parts of a continuous uniform spiral. The holes in the sheets should be tapped with equal accuracy in order that the bolts may fit properly and be free from initial stresses that may be large

encircling them, and preventing them from canting when at work. The fundamental point in the system is the determination of the pitch and angle of the chaser teeth. The difference in the position of the cutting and the leading teeth is shown in Figs. 6 and 7. The real difference is slight, being exaggerated in the drawing in order to be clearly seen. The cutting is all done by the leading teeth, the following teeth only guide the chasers and help to determine the pitch of the thread accu-

ately. The cutting teeth have an ideal cutting clearance on each side of each tooth, and these teeth are relieved of the labor of feeding the die forward. So accurate is the lead-controlling feature that regular dies for market seldom have an error in lead greater than one sixty-fourth in eighteen inches, which is less than one-quarter the average error in standard taps, and less than one-half the error in 90 per cent. of the engine lathes. Thus it is more accurate than the average lead screw and always practically sure, being made by methods insuring invariable accuracy of product and most perfect interchangeability.

Dies made in the usual way have three errors—that due to the lead screw in which the tap or hob is made, the distortion of hardening the tap or hob, and the error of the distortion of the die in hardening it—but Mr. Hartness has only one of these to contend with, viz., the distortion of the chasers in hardening, and this takes place under such favorable conditions as to be inappreciable.

By the efforts of Mr. Hartness the manufacture of stay bolts may be given a refinement not before known, and an improvement in the stay bolt problem must follow his excellent work.

WHEEL WEAR AS AFFECTED BY SIDE BEARINGS.

About a year ago the Lake Shore & Michigan Southern built five express cars. One truck of each of three of them was equipped with the "Frictionless Side Bearing" made by the Chicago Railway Equipment Company, and the other trucks of these cars as well as both trucks of the other two cars were fitted with plain side bearings. Plaster of Paris casts were taken of the contour of the tires on all the wheels before they were put into service and after they had been in service a number of months casts were again taken to show the wear of the treads and flanges during that time. The results are shown in the accompanying engravings, reproduced from outlines furnished by the manufacturers of the bearings. All of the wheels were 36 inches in diameter and steel tired.

In these outlines, those numbered 1 to 4, inclusive, are from the trucks equipped with plain side bearings, and those numbered 5 to 8, inclusive, are from those equipped with the "Automatic Frictionless Side Bearings," the width of the shaded portions showing the amount of wear of each wheel. Car No. 590 runs on the Lake Shore & Michigan Southern express between Chicago and New York via the Lehigh Valley

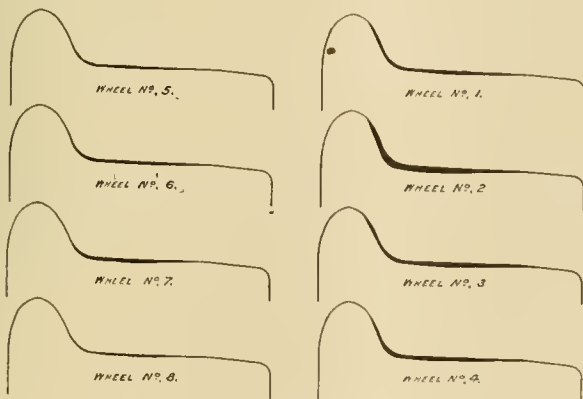

Diagrams from Baggage Car No. 590.

and Delaware, Lackawanna & Western roads, and when the casts were taken, December 1, 1897, the car had made 72,605 miles. The other car, No. 591, made 61,940 miles during the time of the tests, while running over the same route. Two of the cars fitted with plain bearings, the diagrams from which are not reproduced, showed greater wear than either of the others with mileages of only 57,113 and 53,112 respectively. The contour diagrams were taken by Mr. A. M. Waitt, General Master Car Builder of the road, who writes us as follows:

"A singular thing in connection with this is, that on the

trucks having the special side bearings there is no perceptible flange wear on the wheels, while on the truck on the same car having common side bearings there is quite a perceptible flange wear. On both of the trucks having plain side bearings all around, there is a decided flange wear. The cars having plain side bearings ran 52,000 and 57,000 miles respectively, while those having the special side bearings have run as high as

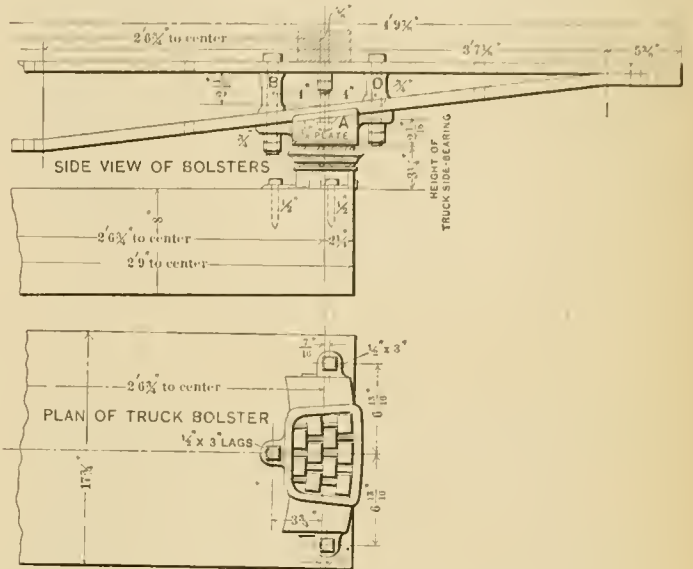

Side Bearing Fitted to Lake Shore Baggage Cars.

72,000 miles. The results convince me that there is a strong call for some device on passenger equipment to relieve the large amount of wear on wheel flanges occurring when passing around curves. The device I have tried has proven its efficiency and I am now applying more of them."

The matter of flange wear is very important not only as regards the expense of turning ties frequently, but also on account of the resistance of trains on curves when trucks are so bound by the side bearings that they do not curve easily. Tires often require turning on account of flange wear before the work becomes necessary from the wear of the treads.

In our engravings we include one showing the form of the roller bearings used on these cars and the method of attach-

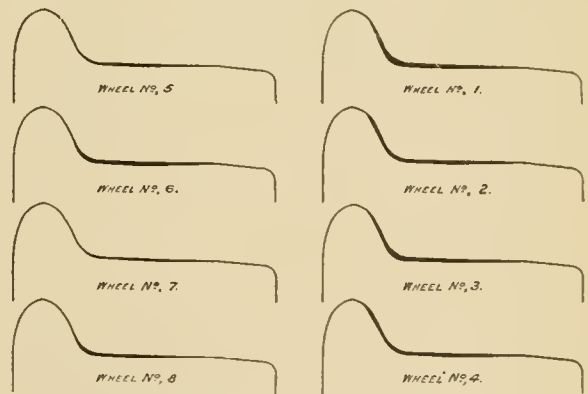

Diagrams from Baggage Car No. 591.

ment to the bolsters. We are informed that these side bearings have been applied upon some fifty railroads and that they are reported as giving excellent service.

A 900-foot dry dock has been decided upon by the Newport News Shipbuilding and Dry Dock Company, of Newport News, Va. It is to be commenced at once and will cost about \$1,000,000. Its width is to be 90 feet and it will accommodate two of our largest battleships at once. The work will be done without Government assistance.

LOCOMOTIVE DESIGN.

The Working Stress of Materials.

By Francis J. Cole.

One of the problems in designing machinery, which requires experience and good judgment, is the determination of the proper working stress of the various parts, and of the different kinds of material used in its construction and with one or two exceptions, there is no class of machinery to which this applies with so much force as to the locomotive. The complex strains to which many of the parts are subjected, caused by running at high speeds over uneven tracks, the fact that the boiler is part of the moving machine, the necessity for carrying the whole structure on springs, and other causes incident to its operation, all tend to render the conditions and stresses more than ordinarily involved.

The ideal engine, as regards durability, is one which would show no decrease of power, no structural weakness, but a gradual decadence, a lack of economy in operating, rather than any local debility, causing its final consignment to the scrap heap.

For several years the breakages causing delays to trains, on a railroad operating between 800 and 900 locomotives, were reported systematically to the writer. Those due to improper design, structural weakness or poor material were investigated, and the stresses to which the broken parts were subjected were carefully studied. Experiments were made and remedies proposed which nearly always resulted in a marked

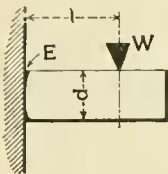

Fig. 1.

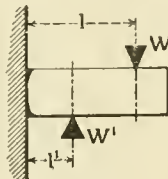

Fig. 2.

decrease of breakdowns when the conditions admitted of a prompt renewal of the weak parts. This did not always take the form of more metal or even better material, but often in a more suitable design to resist the strains to which the member was subjected.

The working stresses in locomotive parts have a wide range, the maximum being found in elliptic springs at about 80,000 pounds and the minimum in spring hangers at about 4,000 pounds per square inch. When the suitable working stresses are determined it is a comparatively easy matter to design the parts and these articles will treat of a few of the most important parts, with suggestions as to working stresses for each, founded on the forces involved (many of the forces are unknown and cannot be calculated) and adapted to the functions of those parts, with a view of designing them so that they will not be large and clumsy, or, on the other hand, too light for the service required.

Crank Pins.

What are the proper proportions for locomotive crank pins? If we use the dimensions of pins of engines in actual service and calculate their fibre stresses, a range, much greater than good practice would indicate, will most likely be found to exist. Unless a comprehensive investigation is made, and the question analyzed at some length, the limits of size and of maximum fibre stresses may not be clearly discerned among the erratic dimensions and proportions produced by guess work and empirical designing. From 8,000 to 29,000 pounds fibre stress per square inch have been found in locomotives built by different makers, in crank pins other than the short front or back ones used on mogul, ten wheel, consolidation or on types where the rod comes close against the hub of the wheel. In the latter cases the size is determined by the bearing surface, the lever arm or distance from the center of the rod to

the wheel being so short that the bending of the pin need not be considered. The stress on any crank pin can be easily found by regarding it as a circular beam fixed at one end, and loaded at the other, with or without the support or counter moment of a rod between it and the wheel or outside. The section modulus or moment of resistance for solid circular

$$\text{sections} = \frac{\pi d^3}{32} \text{ reducing to } 0.0982d^3.$$

The extreme fibre stress at E, Fig. 1, with a single load W is, $S = \frac{Wl}{0.0982d^3}$,

in which:

W=the weight, load or push in pounds.

l=the length to center of W in inches.

d=diameter.

S=maximum fibre stress per square inch.

R=section modulus.

Then: $d = \sqrt[3]{\frac{Wl}{0.0982S}}$ $R = \frac{Wl}{S}$

Taking for example a ten wheel or mogul engine where the main rod is outside the parallel rods, the fibre strain for the assumed dimensions will be as follows:

Cylinder 20 inches diameter, steam pressure 180 pounds, distance l from face of hub to center of cylinder, eight inches, diameter of pin at hub or wheel fit six and one-half inches.

Then: $S = \frac{Wl}{0.0982d^3} = \frac{20^2 \times .7854 \times 180 \times 8}{.0982 \times 6^3} = 16,766$ pounds.

This is the maximum stress due to the steam pressure which the crank pin is required to bear. If, however, the cylinder compression runs up above the boiler pressure or water is allowed to accumulate, the stress at the ends of the stroke will be greater. Normally, the entire thrust of the piston multiplied by the lever arm "l" is not the true bending moment, as the support of the parallel rod must be considered.

Fig. 2 shows this condition, with the support or counter moment W¹. The primary bending moment is 452,160 inch pounds. The counter moment when l¹=3½ inches will be two-thirds the total thrust of the piston multiplied by 3½ = $\frac{W \times 2 \times 3.5}{3} = 131,880$ pounds. This is shown in Fig. 3.

The main rod transmits 56,520 pounds to the end of the main crank pin, one-third or 18,840 pounds is dropped off at the main wheel, one-third is transmitted to the front and one-third to the rear wheels though the parallel rod. The actual bending moment is 452,160—131,880=320,280 pounds. The

actual working fibre stress then of the crank pin is $\frac{320,280}{26.96} =$

11,880 pounds. In all engines of the ten wheel, mogul, consolidation, or any type with the main rod on the outside, the main pin is the only one which need be calculated for bending. If the bearing surfaces of the other pins approach reasonable sizes, the strength, owing to the shortness of the lever arm, will be more than sufficient.

In eight wheel engines of the American type, in which the main rod is next the wheel, the greatest stress is on the back pin, the main pins rarely breaking in service. The reason is apparent upon an examination of Fig. 4. For a 17 inch cylinder and steam pressure of 180 pounds, the piston thrust equals 40,860 pounds. Distance from center of main rod to face of wheel 2½ inches, from center of parallel rod to wheel 7½ inches. The bending moment for the main pin, due to the thrust of the main rod, is 40,860×2.5=102,150 pounds. The bending moment from the reaction of the parallel rod is 40,860×7.125

$\frac{40,860 \times 7.125}{2} = 145,563$ pounds. Then 145,563—102,150,

or 43,413 pounds, is the actual bending moment. On the back pin, owing to the absence of any support, the bending moment is much greater, as it must bear the entire pressure of

half the piston thrust, multiplied by the distance from the center of the parallel rod to the wheel hub. This is $40,860 \times 7.125$

$\frac{1}{2} = 145,563$ pounds. It is a well known fact that the back pins on this type of engine break much more frequently than the main pins, owing to the prevailing and erroneous custom of making the wheel fit diameters the same for both pins, basing the size on the requirements of the main pin. It is evident that the maximum fibre stress is much greater in the back pins.

The section modulus for any solid circular section from $1\frac{1}{2}$ to 9 inches diameter is given in diagram Fig. 5; by following the vertical lines from the figures at the base line, correspond-

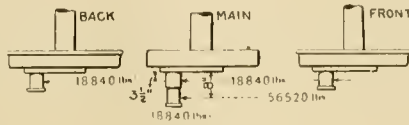

Fig. 3.

ing to the required figure to its intersection with the curved line, the diameter for a given fibre stress can be obtained without any further calculation, or vice versa, for a given diameter the section modulus for that size is shown.

For a good quality of steel, having an ultimate strength of about 80,000 pounds, with a minimum elongation of 18 per cent. the working stress (taking into consideration the support or influence of the parallel rod), should not exceed 14,000 pounds for locomotives having the main rods outside, the range probably being from 12,000 to 14,000 pounds, and 12,000 pounds for locomotives having the main rods inside the parallel rods,

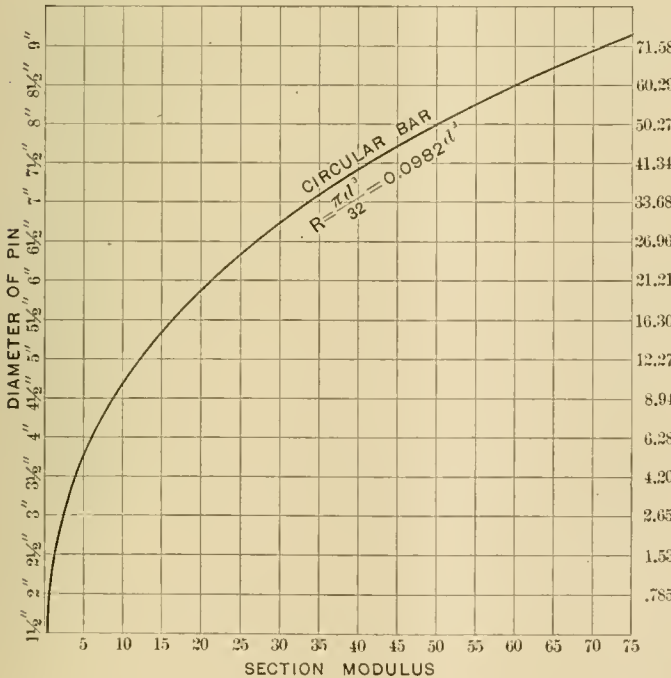

Fig. 5.

with a range of from 10,000 to 12,000 pounds. For hammered iron 11,000 to 12,000 in the first case and 9,000 to 10,500 pounds in the second. If these limits are exceeded by 25 or 30 per cent. breakages are liable to occur in time. A number of instances to support this statement could be cited, showing that the margin of safety is quite small. The liability to exceed the figured stresses is due largely to the variation in the adhesion on the track of the different wheels, with sand under the rear wheels and the main resting on a slippery part of the rail, the force transmitted to the back pins will be considerably increased. It is also liable to be increased above

the normal by the non-parallelism of the rods, caused by the cranks varying from the quarter or 90 degree point and improper adjustment of the wedges in the frame pedestals, causing a difference in length between the rod and the axle centers.

The range of working stresses is graphically shown in Fig. 6. The area enclosed between the curved lines marked 15,000 and 12,000 pounds, shaded with horizontal lines, represents the "working field" or range of stress which it is advisable to use for crank pins for ten wheel, mogul, consolidation, or any type having the main rod outside the parallel connecting rod as shown in Fig. 3. Similarly the area between the lines marked 12,000 and 10,000 pounds, shaded with vertical lines, represents the limits for engines with the main rod inside the parallel con-

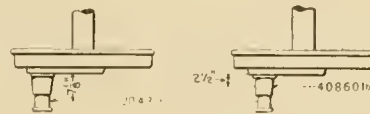

Fig. 4.

necting rod (Fig. 4). This diagram gives the diameter of crank pins for fibre stresses between 10,000 and 15,000 pounds. The bending moments are given in inch pounds, that is, the force or pressure on the pin multiplied by the distance in inches, of the center of the rod to the wheel hub.

The simplest method, which is also a satisfactory one, is to disregard the support of the parallel rod, and use for steel of good quality a stress of 15,000 pounds for freight engines and 11,000 pounds for passenger engines, under the conditions of position of main rod as before described. Thus, for a 19 inch cylinder freight engine, 180 pounds of steam, $7\frac{1}{2}$ inch lever arm (center of rod to wheel hub), the bending moment would be $283 \times 180 \times 7.5 = 382,050$ pounds. Following the horizontal line corresponding to this figure to its intersection with the curved line marked 15,000 pounds, and then down the vertical line to the base, the diameter, $6\frac{3}{8}$ inches, will be found. For the diameter of a rear pin for a passenger engine having the same dimensions, half the amount only would be transmitted

$$\frac{382,050}{2} = 191,025.$$

Following the horizontal line along to its intersection with the curved line marked 10,000 pounds, and then down the vertical line to the base, the diameter $5\frac{3}{4}$ inches is found. In the first instance (freight engine) the force on the main pin is not greatly increased by any variation in the coefficient of adhesion, hence the use of the higher stress. In the second (passenger engine) the force transmitted to the rear pin can be largely increased by a variation in the adhesion of the main and rear pair of wheels.

(To be continued.)

Coal records are to form the basis of the relative standing and promotion of the enginemen on the Wabash Railroad, according to a circular, a copy of which has been received from Mr. George M. Burns, fuel agent of the road. After announcing this fact, the circular explains the use of a new coal ticket and urges men to exert themselves to stand at the head of the list, and shows the importance of careful attention to the admission of air under the grates, continuing as follows: "Engineers should use good judgment in the use of the injector, as economical firing cannot be done unless water is supplied to the boiler regularly. Attention is also called to the importance of using the feed water heater, as by that means warm water is supplied to the boiler, thus saving considerable heat energy. Water in tenders should be heated to from 70 to 90 degrees before leaving terminals. The injector heaters should be used to prevent popping off and at the same time to assist in heating water in the tender." The loss of fuel by blowing at safety valves is troubling many mechanical officers, and they will probably be glad to have attention again called to the possibility of utilizing this heat in the feed water.

(Established 1832.)

AMERICAN ENGINEER

CAR BUILDER AND RAILROAD JOURNAL.

29TH YEAR.

67TH YEAR.

PUBLISHED MONTHLY

BY

R. M. VAN ARSDALE,

MORSE BUILDING.....NEW YORK

G. M. BASFORD, Editor.

APRIL, 1898.

Subscription.—\$2.00 a year for the United States and Canada; \$2.50 a year to Foreign Countries embraced in the Universal Postal Union. Subscriptions for this paper will be received and copies kept for sale by the Post Office News Co., 217 Dearborn Street, Chicago, Ill.

EDITORIAL ANNOUNCEMENTS.

Advertisements.—Nothing will be inserted in this journal for pay, EXCEPT IN THE ADVERTISING PAGES. The reading pages will contain only such matter as we consider of interest to our readers.

Special Notice.—As the AMERICAN ENGINEER, CAR BUILDER AND RAILROAD JOURNAL is printed and ready for mailing on the last day of the month, correspondence, advertisements, etc., intended for insertion must be received not later than the 20th day of each month.

Contributions.—Articles relating to railway rolling stock construction and management and kindred topics, by those who are practically acquainted with these subjects, are specially desired. Also early notices of official changes, and additions of new equipment for the road or the shop, by purchase or construction.

To Subscribers.—The AMERICAN ENGINEER, CAR BUILDER AND RAILROAD JOURNAL is mailed regularly to every subscriber each month. Any subscriber who fails to receive his paper ought at once to notify the postmaster at the office of delivery, and in case the paper is not then obtained this office should be notified, so that the missing paper may be supplied. When a subscriber changes his address he ought to notify this office at once, so that the paper may be sent to the proper destination.

The paper may be obtained and subscriptions for it sent to the following agencies: Chicago, Post Office News Co., 217 Dearborn Street. London, Eng., Sampson Low, Marston & Co., Limited St. Dunstan's House, Fetter Lane, E. C.

Why is it with all the technical schools preparing young engineers that one of the leading trunk railroads, and a large car manufacturing concern, as shown by correspondence in this office, have difficulty in securing satisfactory draftsmen?

A unique series of very valuable illustrated articles on the practical subject, "Locomotive Design; The Working Stresses of Material," by Mr. F. J. Cole, begins in this issue. The articles are written by a well known mechanical engineer, who has not only had years of experience in the designing of locomotives and their details, but has also personally watched the effects of good and bad designing. The articles need no preface at our hands, but that something of this sort is sorely needed in many quarters is shown by a remark made by Mr. L. R. Pomeroy at a recent meeting of the Western Railway Club, to the effect that a consolidation engine with 180 pounds boiler pressure and 19 by 24-inch cylinders had come to his notice, the main crank pins of which were only $\frac{3}{4}$ -inch larger than are used on the elevated roads of New York. He further stated that after calculating the fibre stresses of many crank

pins he had found them to run over 25,000 and 28,000 pounds per square inch, and the same thing was true of axles. The subject is one that will always be important, because of the influence of good designing in reducing the cost of repairs and the losses due to breakdowns on the road. All roads are following up the matter of engine failures and we are confident that the careful work that Mr. Cole has done will be valuable to a great many of our readers. We do not know of any other systematic, thorough treatment of this subject to be found in print.

A valuable suggestion is made by "Motive Power" in this issue when he says that he knows of "no reason why each department should not be made to pay its own expenses, and frequently it becomes purely and simply a question of improved facilities to be used in preference to the facilities then in service." In successful commercial engineering work, departments that do not pay are made to pay or are cut off, and it has been noted in these columns that sometimes very expensive machinery is sacrificed in order to give place to that which will turn out the product at reduced expense. An example is known in which tools valued at \$40,000 were laid aside on this account. There is much in commercial practice that should be copied in railroad work, one principle being a consolidation of the work of one kind at one point. There are few roads small enough to permit of concentrating all of the repair work to rolling stock at one place, and the tendency has been to erect complete shop plants at various convenient points along the line, the chief difference between the plants being as regards their size. Of late the idea of specializing these shops to a certain extent has been growing, and for work requiring expensive machinery, it has been found desirable to provide sufficient capacity for the special work of one kind for the entire road at one of the shops. A good example of this is seen in the installation of a large hydraulic riveting plant at the Chicago shops of the Chicago & Northwestern Railway, and it is recognized as highly important that such machinery should be kept in constant use in order to make it earn its living. This idea has not been carried as far as it may be and ought to be, and particularly with regard to small work, of which a great deal is ordinarily done about railroad shops. A case in point is a road with two large shop plants, each being equipped with a rather elaborate brass working department, while there is not work enough to keep one of them in continuous service. A close cost-keeping record would soon show the commercial weakness of such a plan, and we believe that a system of accounting for the cost of work done in each department would pay for the clerical expense many times over. The money invested in a number of ordinary brass working tools might better be spent upon a single effective equipment, and in general it may be said to be a good plan to concentrate the work that may be called "standard" at one point when it is possible to do so.

ELECTRIC CRANES vs. TRANSFER TABLES.

The most convenient location of pits in locomotive repair shops was discussed at the January meeting of the Western Railway Club, and while preferences were expressed for each plan, the longitudinal, and the cross tracks, yet no good reasons were given for the use of the latter. The transfer table is such a familiar device and shop men are so accustomed to its use that it has come to be regarded as an actual necessity, even when provision has been made for moving locomotives by power inside the building. The Bloomington shops of the Chicago & Alton, the Grant Locomotive Works, and the Burnside shops of the Illinois Central, are illustrations of this fact. Each of them has overhead power cranes of sufficient capacity to lift a complete locomotive and transfer it. Yet they have cross tracks, each with an outdoor opening,

leading to a transfer table and pit. The Boston & Maine shop at Concord, N. H., which we have recently illustrated, is a good example of the longitudinal plan, for here the erecting shop and the boiler shop also are served by the same cranes, and no transfer table is required. Climatic conditions doubtless determine that at Concord the number of outdoor openings should be limited, and that a snow-covered transfer table and pit should, if possible be avoided.

We believe that the advantages of the longitudinal plan have been so well demonstrated in a number of recent shops that we hardly see how it is possible that any more locomotive repair shops with transfer tables can be built. The disadvantages of the transfer table and pit are that they occupy valuable room which cannot be used for anything else. They make an ugly break in the communication between the shops and render it difficult to cross them by men or material. They can only serve a limited purpose of shifting engines sidewise from one track to another, and they serve no useful purpose in lifting material as does the equivalent transfer crane inside. Overhead cranes may be regarded as transfer tables, placed inside and overhead, and while they perform the only function a transfer table is capable of, they are also in constant requisition for lifting the heavy details of the engines.

For these reasons we cannot understand how there can be any question of a choice between transfer tables and overhead cranes, nor can we understand why, in these days, a new shop should be so planned as to require both. For a man who has long been accustomed to transfer tables, and who is about to plan a new locomotive repair shop, it seems necessary that he make a scientific use of his imagination and get outside of himself. It is only in this way that we can produce original plans which take advantage of the numerous facilities which modern progress so richly affords.

If we are mistaken in regard to the statement that transfer tables for modern locomotive repair shops are obsolete, the advocates of such plans will do us a favor if they will state their advantages, so that we, and our readers, may have a better understanding of the case.

RUBBER HOSE SPECIFICATIONS.

The importance of obtaining good air brake hose is now appreciated more than ever before and there is an increasing dissatisfaction with present methods of guarantees and tests. Last year the Master Car Builders' Association appointed a committee to report on the subject and to consider the prevailing conditions connected with the manufacture and use of air hose and the necessary requirements to insure its being properly made, which is an indication that physical requirements alone are not considered sufficient. It has been customary to subject hose to high-pressure hydraulic tests and accept or reject it upon its ability to meet them. It is now admitted that the pressures were carried absurdly high. Durability is the important commercial requirement with all rubber products and there is no doubt that more attention must be paid to the structure and construction of the hose. It is probable that the report of the committee will give special attention to these features. It has been found most difficult the world over to frame satisfactory specifications for rubber goods and to arrange tests from which intelligent comparisons may be made. This applies to many uses other than those made by railroads, and the reason appears to be that it is difficult to predict the effect of time and service, because of the fact that rubber, unlike steel or iron, has a certain life which is very dependent upon the manufacture of the goods.

Pressure tests, if applied at all, should be used merely to insure perfection of structure and action of the hose under stress, and it might be well to specify limits of expansion under definite pressures. The high-pressure requirements have had a bad effect upon the product, and should not be perpetuated.

They are not only useless, but objectionable, for the reason that, to get high hydraulic strength, heavy, closely woven duck is used, and this not only renders the hose stiff, but it shortens its life by deterioration. The reason for this is that in coating the duck with rubber in the "friction" process the rubber ought to be squeezed entirely through the meshes of the duck, so that both sides of the fabric are protected by rubber. Proper frictioning has much to do with the life of hose and its structure as a preparation for severe service. The duck, if improperly protected by the rubber, deteriorates very rapidly, and its adhesion is also adversely affected.

It is comparatively easy to test short lengths of hose for flexibility by adjusting weights and measuring deflections. Chemical requirements may also be stated and also tensile tests of the rubber may be made. In this connection it is interesting to note that for hose used in the navy yards the government requires that a piece of rubber cut lengthwise of the lining, one-half inch wide and four inches between the jaws must stretch to four times its own length (with a variability of 4 inches more or 2 inches less) with a pull of ten pounds, and it must be capable of stretching to six times its own length with an increased pull, without breaking; and when released the rubber must return in one minute to within one-half inch of its original length of four inches. These requirements are not severe enough for air brake hose and one of the prominent hose manufacturing firms voluntarily makes its own specifications much more rigid than these, and adapts them to the special service of railroads.

Considerable attention has been given to the pull required to unwind the duck of hose and it is possible to specify the pull and time required to unroll a section. The quality and weight of the duck and the rubber, the method of making the inner tube, the "friction" of the duck, the number of "ply" and chemical constituents may be specified, but after considering all of these items the hose will not be worthy of confidence unless made by honest people. Of this anyone may convince himself by spending an hour or two in watching the process of manufacture. The best solution of the whole difficulty, as we understand it, is to purchase from reliable manufacturers and not skimp the price.

ELECTRIC POWER DISTRIBUTION IN SHOPS.

An illustrated description of the power distribution system of a large shop plant is given in this issue. The plan described is very interesting and it also serves to call attention to the fact that railroads have been far behind manufacturing concerns in the matter of power distribution. It is not likely that new plants will be planned without electric distribution, and from present indications many existing shops will probably be remodeled to obtain the benefits of this system. Mr. George Gibbs' admirable paper on this subject read last month before the New York Railroad Club is opportune and every mechanical and managing railroad officer should read and study it, for it is by far the best presentation of this subject that we have seen, and it was written with special reference to the conditions of railroad work.

The efficiency of the transmission system is important in its way, and while it is generally conceded that the advantage lies with electricity, this is relatively unimportant when it is considered that the cost of power is but a very small proportion of the whole cost of shop work. Mr. Gibbs puts it at 2 per cent. of the labor cost and shows that the saving in cost of power from improved transmission is but a small proportion of the saving that may be had by increased labor efficiency and greater convenience. This is illustrated by the statements made by him that the cost of installation of an electric motor to drive a turn table at the West Milwaukee shops of the C., M. & St. P. Ry., was saved in labor in four and one half months, and that the cost of the entire electric motor equipment at the Baldwin Locomotive Works, costing between \$60,000 and

\$70,000, pays for itself every year. Some of this is due to better efficiency, but most of it to improved labor conditions. These are the results that managers want to know and the paper gives a great deal of information as to how the results may be obtained.

The Boston and Maine application was carefully planned with special reference to labor charges. The boilers for all purposes are in a single battery and are tended by a single fireman. The engine, air compressor and generators are in one room, which is an ideal arrangement, and in the only case where direct driving could be used it was used, viz., to drive the planing mill, yet the engine for that purpose is in the power house and drives a shaft through the wall of the building. With such concentration of steam power a condensing system with a cooling tower could probably be used to good advantage, and it would undoubtedly increase the economy of the plant especially where live steam is used for heating.

There is no longer reason to regard electrical machinery as complicated, and attention is called to the extreme simplicity of the induction motors used at Concord. They have no commutators or brushes; they are as simple as a grind stone or emery wheel, and apparently need only to be oiled and otherwise let alone in order to work satisfactorily.

There are many interesting problems in connection with electric driving, such as the best transmission system, the most favorable grouping of machinery and the selection of motors. Authorities differ on many of the details, but one of the best features is the flexibility which permits of experimenting indefinitely until the right arrangement is secured. As we understand it, the matter of first importance is to arrange the plant with special reference to reducing labor charges to the lowest terms.

NOTES.

Switzerland proposes to buy all of its railroads at a cost of about \$200,000,000. The people have voted in favor of the plan, and efforts are now being made to arrange a loan.

The Holland submarine boat has been successfully tried in New York harbor and no difficulty was found in running while submerged, or in remaining at a depth of 14 feet for a half hour. Trials in deeper water are to be made.

Three new battleships and new dry docks at Portsmouth, N. H., Boston, Mass., Algiers, La., Mare Island, Cal., besides the enlargement of the dry docks at League Island, Philadelphia, were authorized in the report of the House Naval Committee. The cost of the battleships is to be \$6,000,000 each.

A reversible steam turbine has been sought for by those most interested in that type of steam engine, the earlier ones being reversed by a special turbine so constructed as to run in a direction opposite to that of the main engines. It is now stated upon good authority that Mr. Parsons has solved the problem by an arrangement of valves whereby the steam may be driven through the blades of the wheel in either direction and the entire power of the turbine be utilized in driving in the reverse direction.

Stand-pipes, instead of wooden tanks are used at a number of water stations on the Chicago, Rock Island & Pacific Railway. They range from 30 to 130 feet in height and from 12 to 30 feet in diameter. These stand-pipes are considered cheaper than the wooden tanks and it is thought to be more advantageous to rest these stand-pipes on the ground and make them high enough to give sufficient head than to elevate the bottoms of the tanks. A part of the storage space of the stand-pipes is not available for giving a head, but this method is found cheaper than the other.

The special train by which the Government sent the Alaska relief expedition from Jersey City to Seattle made the trip of

3,139 miles in 129 hours, or at a speed of nearly 25 miles per hour across the continent, which is remarkable for freight train speed. The Pennsylvania took the train to Chicago and the Chicago, Milwaukee & St. Paul took it to Minneapolis, where it was delivered to the Great Northern for the run to Seattle. There were 38 cars in the train, 19 in each section, and of these ten were occupied by the Laplanders and three were filled with moss, which was to feed the reindeer until their arrival in Alaska.

The magnificent showing made by the Pennsylvania Railroad in its annual report is a most encouraging feature in the business world. There were exceedingly heavy expenditures during the year, calling for almost two million dollars to be reserved for unusual work, but in spite of this a five per cent. dividend was paid, and an eight per cent. dividend was earned besides meeting all fixed charges. There was no increase in the bonded debt, but some of the bonds bearing a high rate of interest were refunded at lower rates. This road is a great commercial thoroughfare, and that it is in such excellent condition is reason for congratulation the country over, because of the reflection of good business conditions which is shown.

In commenting recently upon the punctuality of American trains in the London "Times" Mr. W. M. Acworth said: "If I were to give in one sentence, the reason why American trains in spite of great difficulties are excellently punctual, I should say it was because punctuality is insisted on. Instead of engines being sent out, as often happens here, with trains that they are evidently and notoriously incapable of hauling to time, engines are built powerful enough to play with their trains. I stood one night on the platform of the huge Union depot at St. Louis, where the trains of 22 different companies converge, and watched one express after another start out. Many of them weighed at least 400 tons, most of them certainly over 300. Yet not once did I see a driving wheel slip at starting."

Mr. Frederick A. Delano, Superintendent of the Chicago terminals of the Chicago, Burlington & Quincy, gave the tenth lecture in the series of addresses on railway subjects before the engineering students of Purdue University, March 9. His subject was "Railway Signaling." After carefully classifying such signals according to their form and the purpose for which they are employed, Mr. Delano confined his attention to a discussion of the fundamental principles affecting the operation and interpretation of fixed signals. He traced the historical development of the signal idea, discussed the larger and more general questions involved, and disclosed the tendencies of present practice. The lecture was illustrated by means of models and diagrams, which will be given in connection with the text as finally published by the University.

The Crowden system of hydraulic jointing of bicycle tubes is one of the most promising of recent mechanical improvements, and while its widest field is in the construction of bicycle frames the process may also be used for other purposes. Briefly stated the process for making the joints in tubular bicycle frames employs a jig, into which the bicycle frame fits closely. At the joints grooves are cut in the jig with right and left handed spirals crossing each other. The joints are made by applying hydraulic pressure to the interior of the tubular frames, which presses the tubes at the joints into the grooves, and as the metal is strained beyond its elastic limit in the grooves it remains in the form given by the jig. The frame is not distorted by the pressure except at the joints, because of the support given it by the close fitting jig. This process is likely to work a great change in the manufacture of bicycles, and its best recommendation is that heat and brazing are not necessary. It is the invention of Charles T. Crowden, who has obtained patents upon it. Another wide field may be found for it in the fixing of tubes in boilers.

Communications.

PRIZES FOR STATION AND TRACK PLANS FOR SWEDEN.

Editor American Engineer:

The Royal Administration of the Swedish State Railways invites civil engineers or other interested parties to a competition of designs for the arrangement of new Railroad Stations, etc., for the City of Stockholm.

The first prize is to be 12,000 Swedish crowns (about \$3,230); the second, 8,000 Swedish crowns (about \$2,150), and the third, 4,000 Swedish crowns (about \$1,075). The time for competition will expire at noon on the 31st of August, 1898.

Particulars concerning the nature of the work will be furnished by the Swedish-Norwegian Legation, 2011 Q street, Washington, D. C., or by the Vice Consul of Sweden and Norway, Mr. August Peterson, LeDroit Building, corner F and Eighth streets, Washington, D. C. Security to the amount of \$13.50 for the use of the drawings in this competition is required, but this will be refunded when the drawings are returned.

It is hoped that American engineers will carry off some, if not all, of the above generous prizes.

AUGUST PETERSON,

Vice Consul, Sweden and Norway.

Royal Swedish and Norwegian Vice-Consulate,
Washington, D. C., March 12, 1898.

AMERICAN LOCOMOTIVES FOR RUSSIAN RAILROADS.

Editor American Engineer:

The Baldwin Locomotive Works have in St. Petersburg the most active resident agent that any American firm has in this country, Mr. T. J. Gordon. The said agent has sold lately for his firm three tank engines, each of 36 tons, for the Arekhof branch railroad, and 14 freight engines, Class E, Vaucrain System, and three Baltimore & Ohio type, ten wheel passenger engines for the South Eastern Railroad Company. Of the last mentioned type 60 engines are already running on the Russian Moscow-Kursk line and have given splendid results.

Mr. Gordon has just closed a contract for 20 freight engines, class E, for the new Moscow-Riga Windau Railroad, now under construction. The engines are similar to the 80 engines sold lately to the Vladicaucas Railroad Company.

For the past 20 years Mr. Gordon has been introducing American locomotives, and has built up the Baldwin trade in this country. He has a large and, in fact, the only American interest to-day in the Nicopol-Morioupol Mining and Metallurgical Company, of which Mr. Henry Laud, formerly with the Illinois Steel Company, of Chicago, is the general manager, and Mr. Julian Kennedy, Pittsburg, is the consulting engineer. More particulars about the Marioupol works, constructed by the company, will be given in a following letter.

Another business controlled by American capital is the Sormovo Works, which have established a locomotive department. All their new machinery has come from the United States, and the manager of this department is Mr. Walter F. Dixon, from Paterson, New Jersey. This plant has been established only lately, and has up till now only turned out three locomotives, but the capacity is to be in future 70 engines per year. Mr. Gordon is a stockholder in the Sormovo company.

I was also informed that Mr. Gordon will be shortly in the United States, placing orders for machinery.

A. ZDZARSKI,

Assistant Chief Engineer Great Siberian Railway,
St. Petersburg, February 24, 1898.

ACETYLENE CAR LIGHTING IN CANADA.

Pontiac Pacific Junction Railway Company,
General Superintendent's Office,
Ottawa, Ont., March 11, 1898.

Editor American Engineer:

In answer to your request for information relating to our use of acetylene, I beg to advise that we have been experimenting with acetylene gas for car lighting, and have decided to equip our cars on both roads with this gas. Under the old

system of oil lighting our coaches the 14 light chandeliers gave a poor light; under the acetylene gas system we use but five lights in the body of the coach, and with most satisfactory results, being a far better light than electricity or any gas light now used in coaches in the United States or Canada. I believe we are the first road to inaugurate this system.

In conversation with the local agents for the Niagara Falls Acetylene Gas Generator, the Messrs. Holland Bros., of Ottawa, Ont., I suggested that acetylene gas would be a splendid lighting element for the railway cars, if it could be utilized without danger. Mr. Andrew Holland, one of the proprietors, asserted positively that he could light the cars safely and brilliantly with one of the generators used for house lighting. The problems to be met were:

First: The effect of intense frost, on the gas machine and on the gas when piped between cars with rubber hose, and when the train was running 30 or 40 miles per hour with the mercury away below zero.

Second: The effect of vibration of cars on rough track on the steadiness of light.

Third: The danger of gas escaping from the generator by the agitation of the water in the gas tank.

Fourth: The slopping over of water from the gas tank on floor of car, and in consequence, smell of escaping gas.

Shortly after this conversation I placed the train at Messrs. Holland Bros.' disposal for equipment. A 20-light generator was installed in the baggage car. The cars were temporarily piped for gas fixtures, and the first trial decided that three of the expected difficulties amounted to nothing in actual work—the tank and the gas were not effected by the frost; the lights were not effected by the vibration of the cars, and the illumination was more brilliant than on any train I have ever seen. I believe it to be the most brilliant light used to-day on any train in the United States or Canada.

On through mixed express trains, such as we run on this line, with all the drawbacks of shunting, causing slopping over from the water tank, during our first experiments, the light is so ahead of anything that we have yet seen in economy and convenience that we shall never revert to the oil system of lighting. But where a train has to be broken occasionally and cars shunted, it can readily be seen that such a system could not be worked. Here, again, Messrs. Holland Bros. came to our assistance, and have installed a plant for use in our coaches that requires less carbide and avoids slopping and smell from gas, and is positively safe, because the gas is only generated in such small quantities under low pressure that the amount generated at any one time, if such a thing could happen, an explosion would not break a pane of glass. If the cars were to turn over the lights would go out, and the gas would simply pass away harmlessly into the air, as no fire could possibly result from it. The plant is installed in the toilet room, and it occupies a floor space of about 14x26 inches. Those generators have a capacity for the lighting of six lights of 50-candle power each. The charges in attendance of these generators are so simple that an ordinary chore boy attends to ours without any difficulty or danger. We propose to equip all our cars with the acetylene gas plant, as being the cheapest, safest and most brilliant illuminated for railways yet discovered. The carbide we use is manufactured by the Wilson Carbide Co. of St. Catharines, Ont. It costs \$60 per ton f. o. b. factory, and the lighting of one of our coaches with this light enables the passengers to read their evening papers from any seat in the car, and costs about 25 cents for a six hours' run.

P. W. RESSEMAN,
General Superintendent.

POOLING LOCOMOTIVES.

Editor American Engineer:

On page 54 of your February number is an article on pooling of locomotives, in which this sentence appears: "It is clear that the advocates of pooling have as a rule considered what may be termed the business questions of operation." This is really the kernel of this whole question, and as an advocate of the pool with twelve or thirteen years' experience in handling engines under this system, I wish to emphasize the sentiment expressed in this sentence.

An ideal method of handling engines would seem to be one that not only makes it possible, but practicable and convenient,

to handle motive power with no thought except that of maximum service and economical operation. The ideal method makes it possible to assign engines to this or that train, to run them "last in first out," or "first in last out;" to hold in or send out any engine at any time; to transfer them from one division to another at pleasure; to lay up during periods of dull business all engines that cannot be kept in constant service; to insure opportunities for engine crews to secure the proper rest at all times; in fact, to secure a maximum amount of service with a minimum of power, and at the same time automatically conserve the "rights" of all enginemen, and I know of no system that comes as near securing all these results as pooling. A well regulated pool will of itself secure just these results, and in my experience with regular crews any attempt to follow out some of the ideas advanced would have caused the round house foreman to ask with all seriousness, "Is life worth living?" Any one familiar with the work knows how often great inconveniences and unnecessary expense have been incurred in order to get certain engines and crews out in "their turn" with the regular crew system.

I would like to call attention to a few points in the discussion of this subject at the December, 1897, meeting of the Western Railway Club. On page 146 Mr. Brown says: "According to the business and the mileage made extra crews are added. These extra crews are not compelled to wait for some one to lay off before they can make any mileage, but they run in rotation on all of the engines in their turn, so that the mileage of the extra men will be substantially the same as the men favored with regular engines. According to the business done, the regular crew will make two or three round trips; they are then taken off for one trip and lay in until 'their turn' for rest and recreation."

Here we have a pool pure and simple, with the most essential element left out, that of insuring absolutely and automatically an opportunity for each crew to secure rest after each and every trip. The regular crew, he says, "will make two or three round trips and are then taken off." It is evident that the successful working of this arrangement would require that each trip represented a definite and somewhat uniform amount of work, while the facts are there is nothing more indefinite or uncertain than this very item, hence the evident element of weakness of this method.

Another argument against pooling is the "home instinct." It is this very home instinct that makes the difference in the tonnage hauled, the miles run, the cost of repairs, etc., between the pool and regular crews. We invest in a home, not usually as a business venture, but as a matter of comfort, and it is in our homes we expect to secure that comfort or perhaps luxury and ease which are entirely separate and distinct from our business life; so with the engineer, if he comes to look upon his engine as a home, rather than a machine from which he is expected to secure the maximum output, he will quite likely be much interested in arranging for his personal comfort with just the results claimed in the letters from the superintendents, quoted in the paper referred to, where it is stated that much heavier trains were hauled by the same engines in a pool than with regular crews.

In 1886, when air brakes had been in use on freight trains for many years, the first Burlington brake test demonstrated that they were probably worse than hand brakes. Were air brakes on freight trains abandoned for this reason? Not by any means. They were developed and perfected with results too well known to need comment. Such is the history of nearly all progress. The pooling system is no exception, and, as mentioned in the opening remarks on the paper on pooling, less than eighteen months or two years should not be considered sufficient to get a pool into good working order, and even then it requires the honest and enthusiastic support of those who have to do with it, and not the lukewarm, half-hearted endorsement which is sometimes given to changes which do not meet with immediate personal approval.

A case of failure of this system twenty-three years ago is cited. At that time the locomotive was not built to require the minimum of adjustment and running strains as it is to-day. Much stress is laid on the care of the machine by the engineers, but it is really difficult to see just what real work an engineer can do on an up-to-date engine, with solid end side and main rods, fixed wedges or driving box bearings, metallic packing at all steam joints, automatic oil feeds for all bearings, including driving and engine truck journals.

Notwithstanding the testimony of those who have never tried pooling, I must after many years of experience remain firm in the faith.

March 11, 1898.

R. H. F.

Personals.

Mr. Richard English has resigned as General Master Mechanic of the Santa Fe Pacific, to take effect March 21.

Mr. Hugh J. Jewett, ex-President of the New York, Lake Erie & Western, died at Augusta, Ga., March 6.

Mr. Dwight C. Morgan has resigned as Assistant Engineer of the Illinois Central Railroad, a position which he has held since last August.

Mr. William R. McKeen, Superintendent of the Car Department of the Vandalia shops at Terre Haute, is reported to be about to retire.

Mr. A. M. Stimson, Purchasing Agent of the Cleveland, Cincinnati, Chicago & St. Louis, died in Lafayette, Ind., March 8, after a brief illness.

Mr. T. A. Davis, Master Mechanic of the Wyoming Division of the Union Pacific, has removed his headquarters from Laramie to Cheyenne, Wyo.

Mr. George L. Bradbury, Vice-President and General Manager of the Lake Erie & Western, has been chosen President of the Peoria & Pekin Union.

Mr. C. M. Bissell, general manager of the Findley, Ft. Wayne & Western, is reported to have tendered his resignation, and will be succeeded by Mr. George Chapman.

Mr. W. D. Tyler, President and General Manager of the Washington & Columbia River Railway, has resigned his position owing to the sale of that road to the Northern Pacific.

Mr. Theo. H. Curtis, who has been chief draftsman of the New York, Chicago & St. Louis Railroad, has been given the title of Mechanical Engineer. His Office is at Cleveland, Ohio.

Mr. W. C. Halliday, formerly with the Lake Shore & Michigan Southern, has been appointed Chief Engineer of the Tacoma & Columbia River Railway, with headquarters at Tacoma, Wash.

Baron Ludwig von Erlanger, for many years principal owner of the Alabama Great Southern and other lines of the Queen & Crescent system, died at his home in Frankfort, Germany, February 15.

Mr. George Hargreaves has resigned his position as purchasing agent of the Chicago, Burlington & Quincy Railroad to accept the vice-presidency of the Michigan-Peninsular Car Company of Detroit.

Mr. W. Fred P. Fogg has resigned as General Manager and William D. Patterson, Treasurer, has been appointed Acting General Manager of the Wiscasset & Quebec, with headquarters at Wiscasset, Me.

Mr. W. J. Calhoun, of Danville, Ill., has been selected to succeed Mr. Morrison as a member of the Interstate Commerce Commission. He is a lawyer of recognized ability and integrity and a strong man.

Mr. P. N. Hyden has been appointed to assist the Master Car Builder of the L. S. & M. S. Ry. at Cleveland. He was formerly with the Pullman Car Works and later with the McConway & Torley Company.

Mr. F. B. Smith, who has heretofore had the title of Master Mechanic of the New York, New Haven & Hartford Railroad, has been given the title of General Master Mechanic. His headquarters are at New Haven, Conn.

Mr. W. A. Stone, formerly master mechanic of the Southern Railway at Selma, Ala., has been appointed master mechanic of the Montgomery division of the Mobile & Ohio, which is now under construction.

Mr. C. G. Herman of Philadelphia, has been appointed Master Mechanic of the Cornwall Railroad, succeeding A. J. Reed, with headquarters at Lebanon, Pa. Mr. Herman was formerly with the Baldwin Locomotive Works.

Mr. Howard G. Kelley, heretofore Chief Engineer of the St. Louis Southwestern, with headquarters at Tyler, Tex., has been appointed Chief Engineer of the Minneapolis & St. Louis, with headquarters at Minneapolis, Minn., succeeding Mr. Charles Wanzer.

Mr. George G. Yeomans has been appointed Purchasing Agent of the Chicago, Burlington & Quincy and proprietary lines, with headquarters at Chicago, to succeed Mr. George Hargreaves, resigned. Mr. Yeomans has been Assistant Purchasing Agent for the past seven years.

Mr. H. L. Noyes, civil engineer, has severed his connection with the Buffalo Bridge & Iron Works and has opened an office at 846 Ellicot Square, Buffalo, N. Y. He will make a specialty of design and inspection of steel bridges and will also represent the Pittsburg Testing Laboratory.

Mr. Joseph McCabe, formerly Superintendent of the Pacific Division of the Northern Pacific, with headquarters at Tacoma, Wash., has been appointed General Manager of the Washington & Columbia River, with headquarters at Walla Walla, Wash., succeeding W. D. Tyler, recently resigned.

Mr. F. T. Croxon has been appointed Purchasing Agent of the Chicago Junction Railway, which was recently formed by a consolidation of the Chicago, Hammond & Western and the Chicago Junction Railway & Union Stock Yards Company. His headquarters will be at the Union Stock Yards, Chicago.

Mr. E. L. Russell, heretofore First Vice-President and General Counsel of the Mobile & Ohio, was on February 28 chosen President of that road to succeed Mr. James C. Clarke, who declined re-election. Mr. Russell has been General Solicitor and General Counsel of the road since 1876, and was chosen First Vice-President a year ago.

Mr. Richard Carroll, formerly General Manager of the Queen & Crescent system, but who has been engaged in other business for three years, has been appointed Vice-President and General Manager of the Mobile & Ohio, succeeding Mr. J. G. Mann as General Manager. Mr. Carroll was connected with the Queen City & Crescent system for nearly 14 years.

Mr. Jules Viennot, who has for many years carried on the business of advertising agent for a number of manufacturers and railroad supply houses, died March 11, at the age of 73 years. After being connected with several trade publications he took charge of the advertising of the Baldwin Locomotive Works in 1878 and from that time added to the number of concerns for whom he conducted advertising until he had built up a large and profitable business. Mr. Viennot came to this country about 40 years ago and by his agreeable personality made many friends. He also had a high standing in business circles in Philadelphia and enjoyed a prominent social position.

General W. S. Rosecrans died at his home in California on the morning of March 11. He was born in Ohio September 6, 1819, and graduated from West Point in 1842 and entered the Corps of Engineers. He was about four years at the Military Academy as Assistant Professor and served on river and harbor work with the corps for some years, and resigned in 1854 to go into business as an architect and civil engineer.

He served during the Civil War from the very beginning until the end, having reached the rank of Major-General of Volunteers, and he resigned from the regular army in 1867 with the rank of Brevet Major-General. He served as Minister to Mexico, as a member of Congress from California, and, from 1885 to 1893, as Registrar of the United States Treasury.

SIR HENRY BESSEMER.

Probably no individual has exerted a wider influence upon the progress of the century than Sir Henry Bessemer, who died at his residence near London March 15. He was the son of an inventor and inherited skill in mechanical and metallurgical work. He was an inventor while very young, but did not take up the study of iron and steel until 1852, at the age of 39. His first work in this field was in the improvement of cast iron for ordnance, from which he soon turned his attention to the pneumatic working of molten cast iron into steel. The record of his efforts in this his most important work is to be found in a paper, by Sir Henry, in the Transactions of the American Society of Mechanical Engineers, Vol. XVIII., page 455. That the process he invented and perfected is to-day used in the steel trade of Europe and America, producing 10,000,000 tons of steel annually, is a sufficient monument to his ability and usefulness.

Macaulay has said: "Of all inventions, the alphabet and printing press alone excepted, those inventions which abridge distance have done most for civilization." The cheapening of the steel rail has had an incalculable influence upon the distribution of mankind and of the necessities of life, and it is given to few men to improve the condition and surroundings of so many of his fellow men.

He has been honored by societies and by governments, the first distinction being the award of the Albert gold medal by the Prince of Wales in 1872, for "his eminent services to arts, manufactures and commerce in developing the manufacture of steel." His biography is contemporary with the history of the general use of steel and it will be best written when it can be better appreciated than is possible now. He lived at just the right time and was blessed with a clear appreciation of a necessity of vast importance and with the ability and perseverance to solve the difficult problem that presented itself to him.

He lived 85 years and was active in the development of his process until about ten years ago, when he began a life of retirement at his suburban home near London. He may be said to have completed his work, and it was a wonderfully large one.

BOOKS AND PAMPHLETS.

"De Pontibus, a Pocket-Book for Bridge Engineers," by J. A. L. Waddell, C. E., B. A., Sc., M. A. E.; First Edition, 12-mo., Morocco, 416 pages. Price \$3. New York: John Wiley & Sons; London: Chapman & Hall, 1898.

The name of this book represents the character of the work. It means "Concerning Bridges," and is appropriate because there are no illustrations of details of construction, and because principles rather than examples of their application are presented. The work gives the practice of the author, and those parts which are not original represent what he has taken from the practice of others for use in his own work. The subject of stresses is not included, and the reader is referred to other standard works for such information. The book was written for the use of bridge engineers (and it will offer many suggestions to them), for young engineers in bridge manufacturing and designing offices, for professors of civil engineering, for students of civil engineering, for railroad engineers, to whom the specifications given will be valuable, and to the municipal and county officers who have to do with the placing of contracts for highway bridges.

In the introduction the author indicates the importance of

securing the services of an engineer specialist to design and watch the construction of bridges, and states that millions of dollars would have been saved in the construction of the New York and Brooklyn elevated railroads by giving attention to the first principles of design when the plans were made. In the second chapter, under "First Principles of Designing," the author offers many suggestions urging simplicity and directness, systemization of methods, the proper regard for rigidity as well as strength, the importance of architectural effect of structures, and gives many specific forms which he has found to be good practice. Many of these are simple and as old as the art of bridge building, while others are original with the author. It is a good idea to assemble them along with less generally understood principles that are not less important. It is not absolutely necessary to be told that "For members of any importance two rivets do not make an adequate connection," and that "Rivets should not be used in direct tension." There are many little things that may be criticised, but when it is considered that the book gives the practice of a successful engineer of very wide experience, these must be considered very valuable. The author gives considerable attention to "Aesthetics in Design," devoting a chapter to the subject.

The titles of other chapters are as follows: Cantilever bridges, arches, trestles and viaducts, elevated railroads, movable bridges, drawbridges, highway and combined bridges, details, general specifications, specifications for drawbridges, for highway draw spans, general specifications for manufacture, shipment and erection of steel bridges, trestles, viaducts and elevated railroads, compromise standard system of live loads for railway bridges, timber trestles, inspection of material and workmanship, designing of piers, triangulation and office practice. A large number of tables and diagrams worked out and used by the author are given, and the book is provided with a fair index. A great deal of ground is covered for so small a book, and much of it is new in the sense of not having been published in book form before.

This is a unique example of the records of practice from a man standing high in his profession, and while equally good authorities will not agree with the author in all the advice he gives, the book is a very valuable addition to the literature of bridges and metallic structures. The author's style is admirably clear and the book will be understood by readers with only elementary knowledge of the subject.

"Bibliographical Decimal Classification as Applied to Railway Science." By L. Weissenbruch, Principal Engineer Belgian State Railways, General Secretary of the Permanent Commission, Railway Congress. Brussels: P. Weissenbruch, publisher, 45 Rue du Poinçon. Paper, 7x9½ in., 62 pages.

We have received a copy of this pamphlet, which, though occupying 61 pages, is a work of considerable magnitude and one that is sure to be appreciated by those who have found it necessary to the course of their professional work to classify and file information and documents having to do with railroads. This work was the result of the necessity for indexing the ten volumes of the Bulletin of the International Railway Congress, and to provide for the indexing of the regular publications of the Congress as they appear. Another reason for taking it up was in order to present an index to the principal articles that appear in the technical periodicals in different languages that are received at the headquarters of the Congress. Mr. Weissenbruch, after much study of the problem, decided to adopt the Dewey decimal system, which had previously been adopted by the International Institute of Bibliography, founded in 1885 under the patronage of the Belgian Government. This system was worked out and applied to the field covered by the Congress, and this pamphlet gives the classification and its index. The Dewey system is too well known to require explanation here, it being sufficient to say that the whole of human knowledge is divided into ten classes, and a number is given to each. The various subdivisions are indicated by whole numbers and decimals whereby any subject may be instantly located, and the filing and indexing of information be so simplified as to render it possible to turn this work over to a clerk, insuring its being done correctly. It is impossible for any one to arrange a system like this that is entirely free from objection, but the arrangement of this classification is such as to render its faults so small in comparison with its advantages as to make it worth while to send for the pamphlet and make an investigation of its merits. One of its most valuable fea-

tures is that a monthly bibliography of current technical literature is furnished by the publisher of this pamphlet, and this includes the articles that appear in the Bulletin. The author's idea is that this classification and the publication each month of the bibliography of railroads in sheets or slips ready for cutting or pasting upon cards of card catalogue would render a large amount of periodical literature available for permanent record. He considers the decimal classification as an international language, and believes that this form of record will tend to help in the substitution of the magazine article for the book that is out of date the day of its publication.

"The Metallographist, a Quarterly Publication Devoted to the Study of Metals, with Special Reference to Their Physics and Microstructure, Their Industrial Treatment and Application." Edited by Albert Sauveur. Published by the Boston Testing Laboratories, 446 Tremont Street, Boston, Mass. Vol. I., No. 1.

This is the first appearance of a unique periodical, the scope of which is very well covered by the explanatory title. As stated in the introductory chapter, failures of metal structures, rails and axles are due, not to faults of the metals, but in some way they are to be traced to man and his methods of making or using the structures. The development of the present high state of the art of producing and working metals has been due to the work of a number of scientists and investigators, whose researches have been disseminated throughout the scientific papers and the transactions of scientific societies chiefly in France, England, Germany and the United States. The object of the "Metallographist" is to present, once in three months, a clear, exhaustive and comprehensive review of what has been accomplished in metallography during the previous quarter. Work done in the Boston Testing Laboratories will be published, and also original articles by eminent authorities, one of the principal objects being to render the publication valuable industrially. Mr. Sauveur is best known on account of his excellent work in connection with the microscopical examination of steel at the works of the Illinois Steel Company, in Chicago. We wish the new publication encouragement and success.

"Morison Suspension Furnaces for Internal Furnace Boilers."—The Continental Iron Works, New York, Borough of Brooklyn. This 36-page (9 by 11 in size) catalogue has just been issued by the Continental Iron Works to illustrate most recent practice in internal furnace tubular boilers. The opening chapter presents the advantages of the internally fired boiler over those set in brick work, which, on account of radiation and leakage, have been set aside by many progressive engineers in favor of the internally fired type. The boilers constructed by this firm, which are illustrated in the catalogue, contain relatively greater volumes of water than the other type and are designed with special reference to the ease of cleaning. The type of boiler presented here is a modification of the Scotch boiler, embodying the Morison Suspension Furnace. This type is compact, self-contained and consequently cheaper to build than those requiring brick settings. The catalogue describes the Morison Suspension Furnace manufactured in this country solely by this firm, giving a full size detail of the corrugation. It contains a page of notes and suggestions for designing this type of boiler, a form of specification, a large number of strong testimonials, excellent half-tone engravings of boilers now in use and an illustrated description of the Morison patent furnace front and door. Besides these, an important feature of the publication is a series of dimensioned drawings of seven boilers, ranging from 75 to 300 horse-power, with the riveting and the dimensions for four different pressures from 100 pounds up to 200 pounds per square inch. These designs are on sheets folded into the book and elevations of each size applicable to all the pressures are shown, together with scales of measurements and of the riveting. This is an admirable method of assisting purchasers to select a boiler that will meet their requirements and is thought to be new in boiler catalogues. We shall place this volume with the text books on steam boilers in our library, for while it is a catalogue of the best kind the information with regard to the dimensions and construction of boilers entitles it to a place among reference books.

The International Correspondence Schools of Scranton, Pa., have sent us a little pamphlet containing indorsements of the steam engineering courses by eighty-eight students from all parts of the country. The object of these schools is to provide a practical and thorough system of home instruction, without loss of time from work, for all persons interested or engaged in stationary, marine or locomotive steam engineering; for

those who have the care of dynamos and motors; for firemen, oilers, water tenders, coal passers, etc.; for those who wish to qualify themselves to fill positions or conduct business in any of these lines.

This pamphlet is intended to convey to these classes and to young people just starting out in life and about to choose their future occupations, an idea, from the letters of a few of its students in widely scattered parts of the globe, of the thorough and practical instruction which this school is prepared to give wherever written or printed matter can be sent. Those interested should send for a copy.

"Mining, Tunneling and Quarrying," Catalogue No. 41, The Ingersoll Sergeant Drill Co., 26 Cortlandt Street, New York.

This is a new and well-illustrated catalogue of the machinery manufactured by this firm and for which they are well and favorably known. Rock drills, quarry bars, gadders, stone channeling machines and air compressors are illustrated from photographs of machinery as set up for actual work. Besides the illustrations of quarry work a number of engravings are devoted to modern plant for submarine work, showing the drilling and charging. The submarine drilling plant used by P. Sanford Ross and others, and that used on Hay Lake Channel, Mich., by the Gilbert Blasting & Dredging Co., and also that employed for the removal of the iron gates of the Danube in Austria are shown. Detailed drawings of the drills are given with the parts numbered and named for ordering. Those engaged in rock work of any kind will find this catalogue valuable.

The Peerless Rubber Manufacturing Company of 16 Warren street, New York, have just issued a new edition of their catalogue of "Mechanical Rubber Goods." This edition is No. 26 and bears the date of March 1, 1898. Among the new features are specifications for rubber hose which are recommended by this concern and are guaranteed to be met by their goods. The requirements are so rigid as to cause inferior product to fail under it. It is not often that manufacturers issue difficult specifications for themselves to meet and this is a marked indication of the confidence of the concern in its own product. We described the process of manufacturing this hose in our issue of October, 1897, page 335. Another new feature of this catalogue is a description of the "Peerless Hose Nipple Cap," which we illustrated in our January issue of the current volume, page 26. We think the hose specification of sufficient importance to publish in full, which is done in another column.

"Twenty-seventh Annual Report of the Railroad and Warehouse Commission of Illinois." Springfield, Ill., 1897.

This volume is received through the courtesy of Mr. Wm. L. Tarbet, Consulting Engineer of the Commission. It contains the usual statistical information, a detailed report by Mr. Tarbet as to the condition of the different railroads, in which many suggestive notes concerning improvements are made, the usual map showing the present use of interlocking at crossings and showing all of the railroad lines in the State is included, and also a number of excellent half tone engravings of interesting engineering features of recent railroad improvements in the State.

The "Q & C" Co. has distributed a new catalogue of car door equipment and general railroad specialties, including the following: Bryant portable rail saws, Bryant power sawing machines, Dunham car door equipment, Globe ventilators, Mc-Kee brake slack adjuster, N. R. S. protection strip, pressed steel brake shoe keys, pressed steel journal box lids, compound lever jacks, improved inside check valve, lower locking fixtures, metal housing cap, pneumatic cylinder cock controller, Priest snow flanger, self feeding rail drill, shop saws, trolley equipment, trolley separate parts, Williams locomotive valve setting device, and Williams portable stray bolt drilling machine. Copies will be sent upon application.

The Youngstown Bridge Co., of Youngstown, O., has printed a 48-page illustrated pamphlet, presenting a number of half tone engravings of railroad and highway bridges built by them and giving a large number of diagrams of weights of bridges for certain loads and spans and diagrams of reaction and moments, which will be useful to bridge designers. It also contains partial lists of railroad and highway bridges and concerns for whom building work has been done. This company has recently rebuilt its works and installed new machinery which will increase its capacity. It will be remembered that after

being in operation for ten years the plant was burned down last September.

"Mother's Magazine."—A year ago the National Congress of Mothers was started in Washington, D. C., and at once developed into a great national movement, having for its objects the establishment of Mothers' Clubs throughout the country, and the consideration of all matters pertaining to childhood and motherhood, and of the knowledge that science teaches concerning the care of the young and the formation of character. We have just received a copy of the very handsome and interesting "Mother's Magazine," designed to work along the same lines as the Congress of Mothers, and to disseminate, in an attractive form and interesting way the most valuable and instructive information of use to mothers. The magazine is published in New York, by Mr. George H. Baker, and the March number contains 140 pages of handsomely illustrated articles.

"The Birth of Ocqueoc." A legend of the Presque Isle country, Michigan, and other tales, profusely illustrated from photographs taken in the various localities. Not by J. Fennimore Cooper.

This is one of the best illustrated and one of the most attractive pamphlets ever gotten up by a railroad to exhibit the attractions of the farming country and the hunting and fishing resorts along its lines. The engravings are so handsome as to lead to the preservation of the pamphlet, and that is a good deal to say of anything of this kind nowadays. It is devoted to the country reached by the Detroit & Mackinac Railway. Mr. J. D. Hawks, President and General Manager, office at Detroit, will send copies upon application, accompanied by ten cents postage.

The Railway News Bureau of Chicago has printed in a pamphlet the full text of the five bills now before Congress referring to railroads. They are the "Foraker Bill," the "Chicago Bill," the two anti-scalping bills and the "Cullom Bill." The bills in this convenient form will be sought for by many railroad men. The price is 25 cents for single copies and \$1 for five copies.

The Railroad Officials' Diary, 1898, is a standard-size book, with a page for each day of the year, each page being headed with the date printed in bold type. The paper is good, and also the binding, which is of flexible leather. The diary is sent with the compliments of the Railroad Car Journal, 132 Nassau street, New York.

"Massachusetts Institute of Technology. Annual Catalogue 1897-1898. A statement of the Courses of Instruction and a Register of the Alumni; Thirty-third Annual Catalogue of the Officers and Students." Boston, 1898.

"Proceedings of the Seventh Annual Convention of the Association of Railway Superintendents of Bridges and Buildings. Held in Denver, Col., October, 1897." Edited by the Secretary, Mr. S. F. Patterson, Concord, N. H.

MR. A. M. WAITT AT PURDUE.

Mr. A. M. Waitt, General Master Car Builder of the Lake Shore & Michigan Southern Railway, delivered the eleventh lecture in the course of railway addresses before the engineering students at Purdue University March 17.

The course in which Mr. Waitt appeared was arranged with a view of presenting to the advanced students of Purdue the significance of the important problems making up the organization of a railway company. The general plan is to continue from year to year, the expectation being that departments having no representative in any given year will be given a place in the work of succeeding years. Mr. Waitt, representing the car department, called attention to the fact that more than a million cars enter into the equipment of American railways. He described the many different purposes which they are designed to serve, and called attention to the difficulties to be met in maintaining them in good order. The important problems to be met in car design were discussed in connection with a description of the construction of a typical box car. It is safe to say that the students to whom he spoke had never before imagined the variety and number of conditions to be considered in the construction of what to many may seem a rather simple structure. The address was illustrated by means of colored charts which served well to demonstrate the principal points developed.

The next and last lecture of the course will be given by Dr. Charles B. Dudley, of Altoona, who will represent the chemical department of railways.

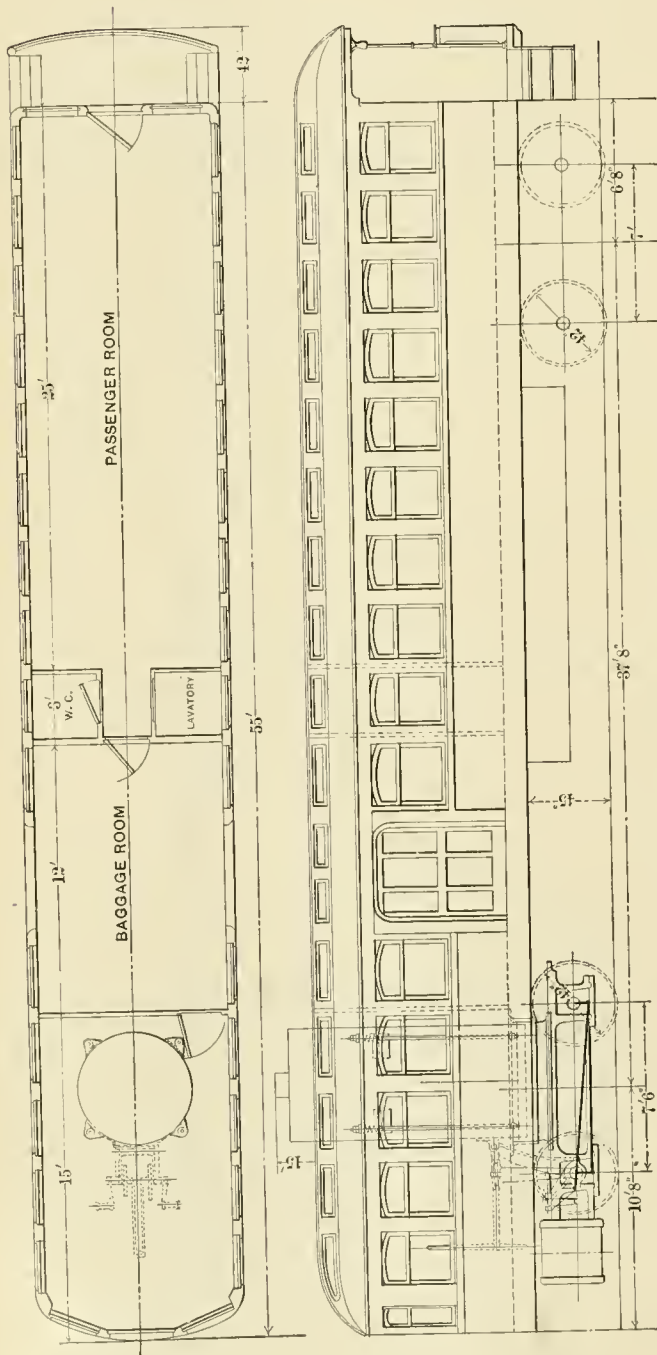

Plan and Elevation of Car for the Detroit & Lima Northern.

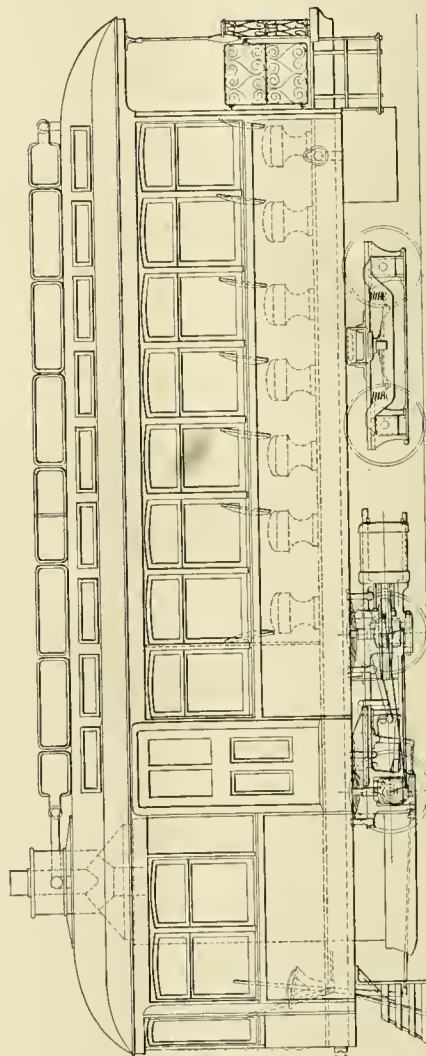

Car for the Cincinnati, Hamilton & Dayton Traction Co.

STEAM MOTOR CARS BY THE BALDWIN LOCOMOTIVE WORKS.

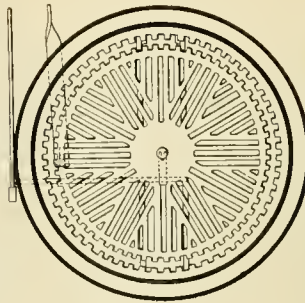
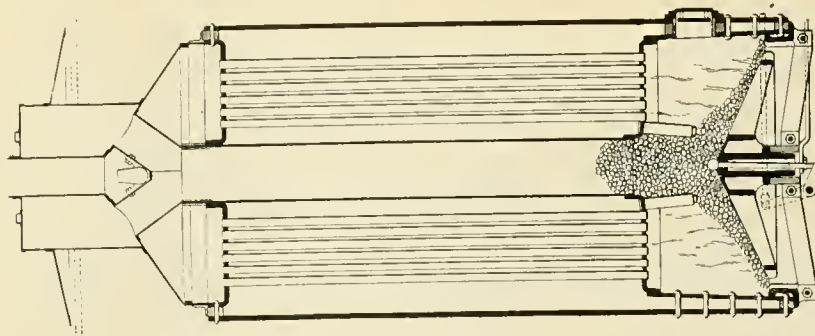

The Magazine Boiler.

STEAM MOTOR CARS BY THE BALDWIN LOCOMOTIVE WORKS.

The Baldwin Locomotive Works have recently completed two steam motor cars, one was built for the Cincinnati, Hamilton & Dayton Traction Co., and is intended for use on the tracks of the C., H. & D. R. R., while the other is for the Detroit & Lima Northern Railway. Both cars are intended to be handled by two men only and the arrangements for the feeding of fuel are made with special reference to this plan. Both locomotives are the Vaucrain compound type and both boilers are self-feeding.

The engravings give a good idea of the construction and the arrangement of the boilers and machinery. The C., H. & D. car is much smaller than the other and the boiler is carried upon the floor of the car body, connection being made to the cylinders through flexible metallic joints of the Moran pattern. The valve motion is attached in the ordinary way to the truck, and is placed between the two driving axles. In trials this car has been run for 38 miles without attention to the fire, and a speed of 42½ miles per hour has been maintained for a distance of 17 miles. The condenser placed upon the roof is not intended for continuous use, but is sufficient to completely condense the steam of the exhaust while running for several miles through towns or thickly settled parts of the line. Whenever practicable, the exhaust is turned directly into the air. The condensation from the exhaust is returned to the tank underneath the car.

The condenser is made of very thin, No. 22, brass tubes 1½ inches in diameter, of which there are 360, so arranged by connections with cast-iron headers that the exhaust passes through the entire length of the radiating surface, and it is sure to be condensed before reaching the end, so that there is no visible or audible exhaust while the condenser is in use.

The boiler, upon which an application for a patent has been made, is of the upright, fire-tubular type, with a ten inch magazine for feeding the grate with coal. The grate is circular and is shaken from the operating compartment by a lever. As shown in the section of the boiler, a rod passes up through the center of the grate and terminates in a ball. By moving this rod up and down by means of a lever, the coal from the magazine may be fed down over the grates as required. A fire door is provided for use if necessary; it is placed beneath the floor, and is reached through a trap in the floor of the car.

Twelve short water tubes project downward into the firebox in such a way as to form a cage to confine the stream of coal from the magazine, and cause it to spread out over the grate. These are two inches in diameter, and into each one a thin sheet-iron circulating tube is dropped from the top end. The heat from the fire causes water to pass upward on the outside of the circulating tubes and downward on the inside. The thin sheet merely forms a partition for this purpose.

These are some of the chief dimensions of the equipment:

Fuel, anthracite coal or coke. Weight in working order, not including passengers, about 48,000 pounds, with about 32,000 pounds on the driving wheels. Cylinders of Vaucrain compound type, high pressure 5½ inches in diameter, low pressure 9 inches in diameter, stroke 12 inches. Driving wheels, 30 inches in outside diameter. Total wheel base, 16 feet 8 inches. Driving wheel base, 5 feet, 0 inch. Driving axles of steel, with journals, 5 by 6 inches. Driving boxes of brass. Boiler, 48 inches in diameter, centrally fired, self-feeding type, being supplied with coal from the top of the car roof around the stack through a 10 inch pipe in the center of the boiler. Boiler of steel ½ inch thick, and carries a working pressure of 180 pounds to the square inch. Tubes of iron, 304 in number, 1¼ inches in diameter and 5 feet long. Fire box 42½ inches in diameter, and 22 inches deep.

The frames supporting the cylinders and driving mechanism are embodied in a swivelling truck which forms a support for the forward end of the car. A four-wheeled swivelling truck

acting simply as a carrier is placed under the rear end of the car and is provided with wheels 30 inches in diameter and axle journals 3½ by 7 inches. The car body is 32 feet 9 inches over all, with clerestory, and is divided into passenger, baggage and engineer's compartments. The passenger compartment, which has a seating capacity for 24 persons, is finished in quartered oak, and is provided with transverse seats with an aisle in the center. The passenger compartment is heated by steam and well lighted. All trimmings are of bronze metal. A toilet room is located at one end of this compartment. The baggage compartment is about 6 feet in length and located between the engine room and passenger compartment, with both of which it communicates.

Two tanks, each with a capacity of 150 gallons, are placed under the car body, from one of which the feed water is taken while the other, being connected with the condenser, receives the water formed by the condensing steam, but both these tanks are connected and supply the feed water to the boiler.

The chief feature of the car for the Detroit & Lima Northern Ry., which is much larger than the other, are the methods of suspension of the front end of the car, and the arrangement of the valve motion. The boiler is the same as the other, but larger, and it is carried directly upon the truck. The boiler turns within the car without requiring jointed steam connections. There is no condenser in this equipment. The cylinders are compounded on the Vaucrain system, and they are 9½ and 16 by 18 inches in size. The boiler is 60 inches in diameter, with 630 square feet of heating surface. It will run 40 miles without attention to the fire and is calculated to make a speed of 40 miles per hour on a level or easy grade, while hauling two or three cars. This is a powerful engine and it is practically a light suburban locomotive combined with a car. The valve motion is inside the car. The eccentric rods are vertical, connecting to the links, which are horizontal and removed from the dust. The valves take their motion from a bell crank connection. This arrangement is patented.

The suspension of the weight of the car is new, a patent having been applied for by Mr. W. L. Austin. The object sought was a free and easy spring hanging, which should not depend upon the trucks for the cushioning. In this case the weight of the car is carried by four rods to lugs secured to the sides of the boiler. These rods transmit the load through long coil springs with spherical seats, and the motion is said to be very satisfactory. The boiler, as already explained, is mounted on the truck with a large guiding casting for the car.

There can be no doubt of the value of these light motors operated by only two men, and it will not be at all surprising to see a large number of them in use on suburban and branch lines in the near future.

FIRES IN NAVAL VESSELS.

A statement prepared by the Board of Naval Officers recently appointed to investigate the subject of spontaneous ignition of coal, summarizes the supposed causes of combustion in eleven out of twenty fires reported on war vessels in the past three years. The Petrel's upper bunker caught fire two years ago at a point 18 inches from the boiler, presumably from the great heat, 200 degrees, in the space between boilers and bunker and to the absence of ventilation, as the ship had been battened down for a week. According to the New York "Sun," the report says that wet coamax coal had been stowed in this bunker repeatedly without any trouble as long as there was some exit for gas.

A fire in the lower bunker of the Olympia was believed to be due to proximity of the boilers and feed tank. The back head of the boiler was about 8 inches from the bunker, but the feed tank adjoined it. Another fire later on the same ship was reported to be due to the proximity of the upper bunkers to the steam pipes and boilers. A fire on the Cincinnati was due to bad bunker ventilation. The heat in this instance was so great that it charred the wood around the shellroom in adjacent magazine, which was separated from the bunker by a single bulkhead only.

Fire in the Indiana's bunkers was due to the location of the bins, which were so placed that anything short of anthracite might ignite. A fire on the Albatross became so intense that red-hot coals nearly burned the floor of the bunkers through. In a number of other instances fire occurred, but practically all the investigations showed that the coal had ignited through proximity of the bunkers to the fire-room or steam boilers or pipes.

NEW STANDARD LOCOMOTIVES—GRAND TRUNK RAILWAY.

An unusual plan was recently adopted by the Grand Trunk Railway in ordering new locomotives. This was a combination of the ideas of Mr. F. W. Morse, Superintendent of Motive Power of the road, with those of the Baldwin and the Schenectady people. The order was divided between the builders, the Baldwin people building four ten-wheel passenger

Weight on drivers.....lbs.	117,000	120,000
“ truck wheels	37,500	20,000
“ total	154,500	140,000
Wheel base, total, of engine.....	26 ft. 11 in.	24 ft. 1 in.
“ driving	15 ft. 8 in.	15 ft. 8 in.
“ total, engine and tender	53 ft. 9 in.	50 ft. 11 in.
Length over all, engine.....	42 ft. 8 in.	39 ft. 10 in.
“ total engine and tender...	64 ft. 11 in.	62 ft. 1 in.
Height, center of boiler above rail	8 ft. 9½ in.	8 ft. 4½ in.
Height of stack above rail.....	14 ft. 7½ in.	14 ft. 2½ in.
Heating surface, firebox.....sq. ft.	189	188.1
“ tubes.....	2,272	1,803
“ total.....	2,461	1,991.1
Grate area	33.43	33.43

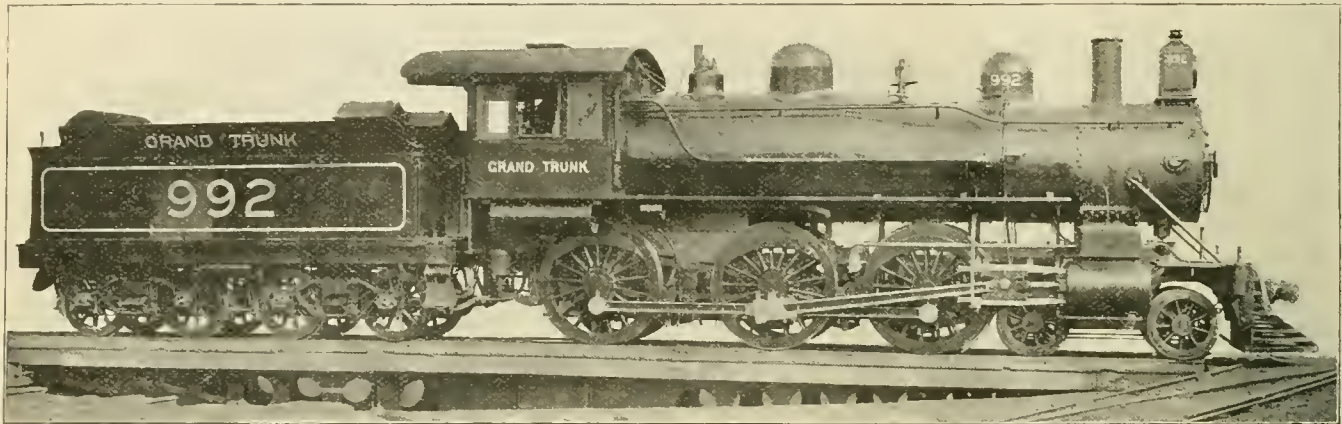

New Standard Ten-Wheel Passenger Locomotive -Grand Trunk Railway.

and six mogul freight engines, while the Schenectady people are building an equal number of each. Our illustrations show the ten-wheel design with the principal dimensions.

The parts as far as possible have been made interchangeable between the two types. How far this has been carried out is apparent in the table of dimensions given below. The boilers are alike, except that the one for the ten-wheel class is 37 inches longer in the first barrel sheet than the other. The fireboxes are 10 feet long. The boiler pressure is 200 pounds. The passenger engines are 14,500 pounds heavier than the freight, but they have 3,000 pounds less weight on the drivers than the others. The heating surface of the passenger engines is 2,461 square feet, as compared with 1,991 square feet for the freight engine, while the grates and fireboxes are the same in both types. The driving axles are all alike, 9½ by 12 inches, which we believe to be the largest ever used in locomotives.

The engines by the Baldwin Locomotive Works are finished and in service, rapid progress having been made on the others by the Schenectady Locomotive Works, which were started later. These engines should be well designed, as very few are the subject of study by the officers of a railroad and two prominent building firms. The object was to secure the best practice as employed in a number of recent designs, and to profit by satisfactory combinations rather than by radical departures from good precedents. We cannot neglect this opportunity to strongly commend this plan of interchangeability. It should be done as often as possible.

The special equipment for the Baldwin engines is briefly noted as follows: Main drivers cast steel, front and back drivers cast iron; steel centers for 10-wheel engines, by the American Steel Casting Co.; steel centers for the moguls, by the Standard Steel Works; axles, engine trucks, springs and bell ringers, by the Baldwin Locomotive Works. The following equipment is the same for both types: Sight feed lubricators by the Detroit Lubricator Co.; front and back M. C. B. coupler and driver brakeshoes by the Grand Trunk Railway; safety valve and mufflers by the Coale Muffler & Safety Valve Co.; air pumps, governors and tender brake equipment by the Westinghouse Air-Brake Co. The driver brake equipment is American. The engines have the Houston sanding device, Sterlingworth tender brakebeams, American tender brakeshoes, Crosby steam gages, United States metallic packing and Adams & Westlake headlights. The lagging of the boilers is wood with asbestos paper above and below. The chief dimensions are as follows:

Builder's class and number.....	Ten-wheel Pass. 10.34 D. 326 to 329	Mogul. 8.34 D. 15 to 20
Number	992 to 995	901 to 906
Gage	4 ft. 8½ in.	4 ft. 8½ in.
Kind of fuel to be used.....	*Bituminous coal.	

* These items are the same for both classes of engines.

Wheels and Journals.		
Diameter of driving wheels.....	72 in.	62 in.
Truck wheels	37 in.	37 in.
Journals, driving axle.....size	9½ in. X 12 in.	9½ in. X 12 in.
“ truck	6½ in. X 10½ in.	6½ in. X 10½ in.
Main crank pin.....	6½ in. X 6 in.	6½ in. X 6 in.
Parallel rod pin.....	5½ in. X 4 in.	5½ in. X 4 in.
Crosshead pin	4 in. X 3½ in.	4 in. X 3½ in.
Cylinders.		
Cylinder diameter	20 in.	20 in.
Piston stroke	26 in.	26 in.
“ rod diam.	3¾ in.	3¾ in.
Main rod, length cen. to cen.....	10 ft. 8¼ in.	7 ft. 7¼ in.
Steam ports, length.....	20 in.	20 in.
“ width	1½ in.	1½ in.
Exhaust ports, length.....	20 in.	20 in.
“ width.....	3 in.	3 in.
Bridge, width	13 in.	13 in.
Valves, kind of.....	*Balanced.	
“ greatest travel	5½ in.	5½ in.
“ outside lap	7 in.	7 in.
“ inside lap	0	0
“ lead in full gear.....	½ in.	½ in.
Boilers.		
Boiler, type of.....	*Extended wagon top.	
“ working steam pressure..	200 lbs.	200 lbs.
“ material of barrel.....	*Steel.	
“ thickness of material in barrel	21-32	21-32
“ diam. of barrel at front sheet	62 in.	62 in.
“ circumferential.....	*Double riveted.	
Thickness of tube sheets.....	5/8 in. front, ½ in. back.	¾ front ½ back
“ crown sheet	¾ in.	¾ in.
Crown stayed with.....	*Radial stays.	
Dome, diameter	31½ in.	31½ in.
Tubes, number	291	291
“ material	*Lap welded iron.	
“ outside diameter	2 in.	2 in.
“ length over tube sheets..	15 ft.	11 ft. 11 in.
Firebox, length	120 in.	120 in.
“ width	40½ in.	40½ in.
“ depth	76¾ f. 65 b.	73¾ f. 65 b.
“ material	*Steel.	
“ thickness of sheets.....	{ Crown, ¾ in.	{ Crown, ¾ in.
“	{ Tube, ½ in.	{ Tube, ½ in.
“	{ Sides, 5-16 in.	{ Sides, 5-16 in.
“	{ Back, ¾ in.	{ Back, ¾ in.
“ Brick arch	*Yes.	
“ water space, with fr'nt sides	4 in.	4 in.
“ “ “ back	3½ in.	3½ in.
“ “ “ “	4 in.	4 in.
Smokebox, diameter	65½ in.	65½ in.
“ length from tube sheet to end.....	5 ft. 10 in.	5 ft. 10 in.
Other Parts.		
Exhaust nozzle	*Fixed, single.	
“ thimbles	5 in., 5¼ in. and 5½ in.	5 in., 5¼ in. and 5½ in.
“ distance of tip above cen. of boiler	6¼ in.	6¼ in.
Smokestack (straight), diam.....	15¼ in.	15¼ in.
“ height above smoke box	37 in.	37 in.
Tender.		
Type	8-wheel	8-wheel
Tank capacity for water.....	4,500	4,500
Coal capacity	10 tons	10 tons

TEN WHEEL LOCOMOTIVE—BOSTON & MAINE R. R.

Sixteen ten wheel freight locomotives have recently been ordered by the Boston & Maine Railroad; six are single expansion type, with 19 by 26-inch cylinders and 36-inch driving wheels, and were ordered from the Manchester Locomotive Works at Manchester, New Hampshire, while the others are two cylinder compounds ordered from the Schenectady Locomotive Works. Both types are from drawings and specifications prepared by the motive power department of the road. The compounds, one of which is illustrated, are to be used on the Concord and White Mountains divisions, both of which are hilly. Four of these have already been delivered and are now entering service, giving promise of very satisfactory results.

Boiler.

Style	Extended wagon top
Outside diameter of first ring.....	58 inches
Working pressure.....	200 pounds
Thickness of plates in barrel and outside of firebox.....	9-16, 3/4, 11-16 and 1/2 inch
Horizontal seams....	Butt joint, sextuple riveted, with wet strip inside and outside
Firebox, length.....	96 inches
" width	42 1/4 inches
" depth	F, 70 inches; B, 61 inches
plates, thickness, sides, 3/8 in.; back, 3/8 in.; crown, 3/4 in.; tube sheet, 1/2 in.	
" water space.....	4 in., front; 3 1/2 in., sides; 3 in., back
Tubes, number of.....	267
" diameter	2 inches
" length over tube sheets.....	13 feet 4 inches
Heating surface, tubes.....	1,852.33 square feet
" firebox	141.4 square feet
" total	1,993.73 square feet
Grate	27.39 square feet
Smoke stack, inside diameter.....	15 1/2 inches
" top above rail.....	13 feet 9 inches

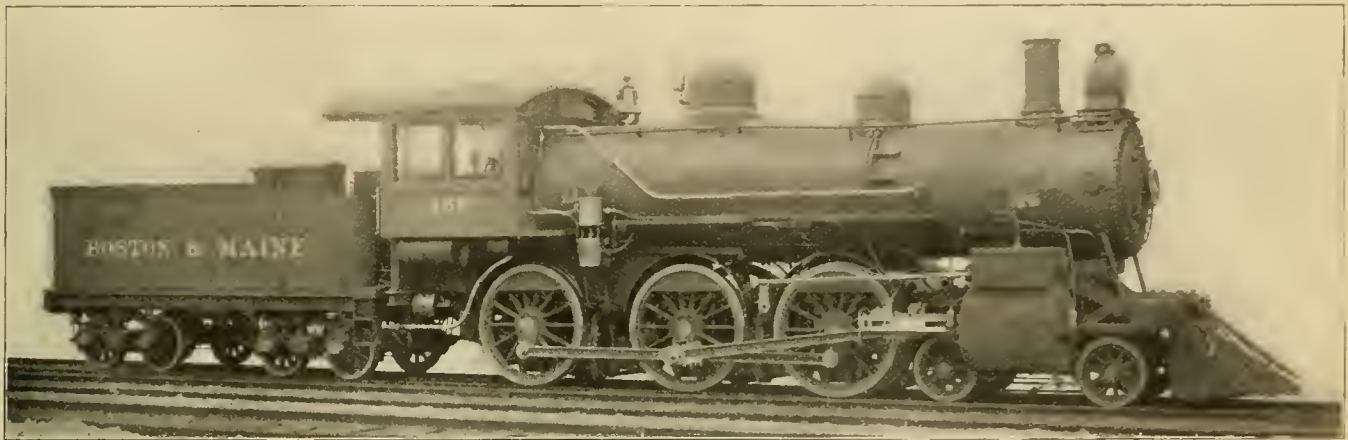

Schenectady Ten-Wheel Compounds—Boston & Maine R. R.

These engines are equipped with two three-inch Ashton safety valves, one Siebert and one Nathan sight feed lubricator, American outside equalized brake on all drivers, Westinghouse air brake on tender and for train, magnesia sectional boiler lagging, National hollow brake beams, Standard truck wheels and Leach sanders. The chief dimensions of the compounds are given below, and as the simple engines are similar, one description answers for both types:

General Dimensions.

Gauge	4 feet 8 1/2 inches
Fuel.....	Bituminous coal
Weight in working order.....	141,000 pounds
" on drivers.....	103,000 pounds
Wheel base, driving.....	14 feet
" " rigid	14 feet
" " total	24 feet 5 inches

Cylinders.

Diameter of cylinders...high pressure, 21 inches; low pressure,	32 inches
Stroke of piston.....	26 inches
Horizontal thickness of piston.....	5 3/4 inches and 4 3/4 inches
Diameter of piston rod.....	3 1/2 inches
Size of steam ports.....	H. P., 20x2 1/2 inches; L. P., 23x2 1/2 inches
" " exhaust "	H. P., 20x3 inches; L. P., 23x3 inches
" " bridges "	1 3/8 inches

Valves.

Kind of slide valves	Allen-Richardson, balanced
Greatest travel of slide valves.....	5.6 inches
Outside lap	H. P., 1 1/4 inches; L. P., 1 1/2 inches
Inside lap	3/4 inch clearance
Lead of valves in full gear.....	—

Wheels, Etc.

Diameter of driving wheels outside of tire.....	63 inches
Material of driving wheels, centers.....	Main, cast steel, F. & B. steeled cast iron
Driving box material.....	Gun iron
Diameter and length of driving journals... 8 inches diameter by	10 inches
" " " " main crank pin journals....	Main side, 6 1/4 x 5 1/4 inches; main, 5 1/2 inches diameter by 6 inches
" " " " side rod crank pin journals...F. & B.	4 1/2 inches diameter by 4 inches
Engine truck, kind.....	4-wheel, swing bolster
" journals	5 1/2 inches diameter by 10 inches
Diameter of engine truck wheels.....	30 inches
Kind	Standard, O. H. steel tired, spoke center

Boiler supplied by 2 Hancock type "B" improved inspirators, size No. 8 Tender.

Weight, empty.....	34,000 pounds
Wheels, number of.....	8
" diameter	33 inches
Journals, diameter and length... 4 1/2 inches diameter by 8 inches	
Wheel base.....	15 feet 8 inches
Tender frame.....	8-inch steel channel
Water capacity.....	4,000 U. S. gallons
Coal	8 tons
Total wheel base of engine and tender.....	49 feet 11 1/4 inches
" length	59 feet 4 1/2 inches

THE HUNT COAL CRACKER.

The Hunt coal cracker is designed for breaking the large lumps in run of mine of bituminous coal into smaller pieces that will feed through the automatic stokers used under the boilers of large steam generating plants. It is believed by

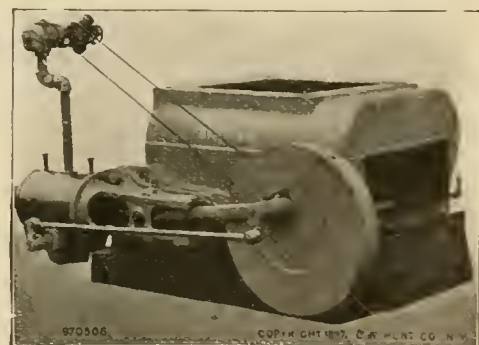

Fig. 1.

many engineers who use hand firing, both in stationary and in locomotive boilers, that it is advantageous to break the larger lumps of coal into smaller sizes, both on account of the easier and more perfect distribution of the coal on the

grates by the fireman and a more perfect combustion resulting from an even fire. The points on the rolls are made of tool steel with hardened ends, especially designed to crack and not to crush the lumps of coal so that none of the advantages of lump coal are lost. The fine coal passes through the rolls unaltered.

The cuts show the cracker driven by a direct connected steam engine having the steam ports and passages all draining continuously downward, the steam entering at the top of the cylinder and the exhaust passing out at the bottom, so that all condensed steam is immediately drained off, and every drop of the water from cylinder condensation is swept out of the cylinder and ports at each stroke of the piston.

The cross-head bearing on the slide is made longer than the stroke of the piston so that it will not uncover a central

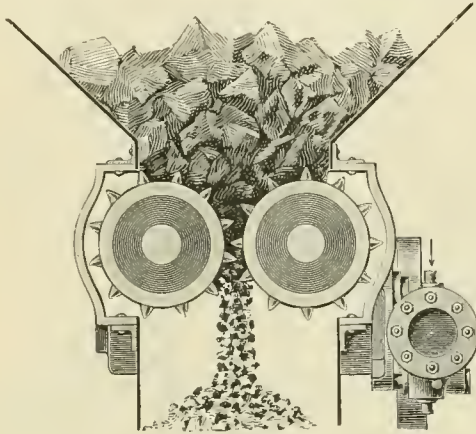

Fig. 2.

oil well, packed with an elastic absorbent packing, that keeps the sliding surface constantly swabbed with oil. The bearing is unusually wide, so that the bearing on the slide is about four times the area generally used.

The rolls are made the proper diameter to break the coal to the size required, and are not adjustable in the frame, thus eliminating all elements that might be sources of weakness and delay. Both the gearing and the rolls are entirely inclosed,

feeding hopper. The breaker may be placed below the hopper under the railway car track so that the coal feeds directly from the car through the rolls into a conveyor which transports it to the storage bins. When coal is hoisted from a vessel the breaker is usually put under the hopper, into which the coal buckets dump.

While the average horse-power consumed by a coal breaker is small, the necessity for strong and perfect construction of the parts under stress must be evident. The axles in the rolls are of steel, large in diameter, and the frame is of massive construction to resist the great and sudden strains that may come upon it, especially when some hard substance accidentally falls in the rolls while running.

These machines can be used to advantage for breaking other hard substances, the rolls in such cases being made to suit the work. They may also be operated from ordinary shafting or by an electric motor instead of a steam engine. The manufacturers, the C. W. Hunt Company, may be addressed at 45 Broadway, New York.

BALDWIN LOCOMOTIVES FOR THE SOUDAN.

The British War Office recently found it necessary to obtain four locomotives upon exceedingly short notice, and not being able to get them from any English builders in time, the order was placed with the Baldwin Locomotive Works, and the photograph shows one of the completed engines. They were ordered by the Consulting Engineer in London for the Soudan Railroad, the order being received in Philadelphia Jan. 6, under agreement to ship the four engines by March 6. An emergency arose and the builders were requested to anticipate the date of delivery, and after the work was started it was accelerated, and shipment made from the works Feb. 9. The engines were received on board the steamship "Stalheim" Feb. 11. Under the terms of the contract the builders have sent a representative to attend to the unloading at Alexandria, the re-loading upon cars and shipment to the Soudan, and the erection and trial for service at their destination.

The general dimensions are: Cylinders, 15x24 inches; weight in working order, 35 tons; driving wheels, 60 inches in diameter; gage of track, 3 feet 6 inches; fuel, petroleum or bituminous coal; boilers, steel; firebox, copper; tubes, brass. The



Baldwin Locomotives for the Soudan.

each in a separate compartment in a cast iron frame. This prevents the coal dust from entering either the bearings of the machinery, the gear box, or the room in which the breaker is located. The gearing is easily accessible, but entirely inclosed and protected from dust while running. The gearing runs in a bath of oil that insures perfect lubrication. The vertical distance between the feeding hopper and the delivery spout is reduced to a minimum as the space available for the cracker is usually limited. A horizontal spindle governor is adjusted in position and so located as not to interfere with the

engines have six-wheel tenders, four of which wheels are in a truck, while the others are in pedestals.

The engines have grates for burning bituminous coal and also tanks and oil injectors for burning petroleum. The details were specially arranged to meet the peculiar conditions of service in the Soudan. They are the first locomotives ever built in this country for Egypt, and the promptness of the Baldwins must be considered wonderful under the circumstances. The rapid work speaks volumes for the equipment and management of the works.

THE COFFIN TOUGHENING PROCESS.

This process of treatment of steel, which has for a number of years been used in the manufacture of axles, crank pins and piston rods for locomotives, was described in detail by the aid of etchings and diagrams in a paper by Mr. L. R. Pomeroy, at the February meeting of the Western Railway Club. The paper shows a careful study of the effects of the heat treatment of steel, the advantages of the Coffin process briefly stated being that the irregularities produced by forging are relieved and the steel brought from an irregular and coarsely crystalline to an amorphous condition, also the elastic limit of the steel is greatly increased without loss of elongation or ductility. The change of the structure was admirably shown in the paper by a number of remarkably clear etchings and the effect upon the elastic limit was exhibited by the following figures for an axle which was cut in two and one-half toughened by the Coffin process, while the other was tested in its natural state:

	Elastic Limit	Ultimate Strength	Elongation Per Cent.	Reduction Per Cent.
	Lbs.	Lbs.	Cent.	Cent.
Untoughened	30,000	71,520	24.50	51.50
Toughened	44,000	72,020	24.07	57.20

During the early days of the use of steel laboratory conclusions had shown that steel was superior to iron and it was taken up by manufacturers for railway purposes, but difficulties were soon found in the form of mysterious breakages which are now known to have been caused by the forging stresses which this process was designed to remove, the process having now been used successfully for eight or ten years. The

which increases the elastic limit at the expense of raising the ultimate strength is an illegitimate method of arriving at the ideal results, because with mechanical working the elastic limit will follow the ultimate strength through the various manipulations; this point is very strongly brought out in the tests cited. We have here two tests of the Coffin process—one .42 carbon and the other .36 carbon; the tensile strength of the .42 carbon was increased 2 per cent., while the elastic limit was increased 36 per cent. On the .36 carbon the tensile strength was increased only .007 per cent., while the elastic limit was increased 46 per cent. This clearly indicates that we have obtained the increase in elastic limit, not at the expense of raising the ultimate strength, but in a legitimate way.

BROOKS LOCOMOTIVES FOR KOREA.

Last month the fact that the Brooks Locomotive Works had received the order for four locomotives for the Seoul-Chemulpo Railway in Korea was noted, these locomotives have been completed and one of them is illustrated by the accompanying cut.

Last year an American firm secured from the Royal Government of Korea a concession to build a railroad, the first and only one in that country, and notwithstanding constant political disturbances its construction and equipment have gone steadily forward. This railroad is of the American standard gauge (4 feet 8½ inches) and is known as the Seoul-Chemulpo Railway extending from Seoul, the capital of Korea, on the north to Chemulpo, the chief seaport on the south, a distance of about 25 miles.



Brooks Locomotives for Korea.

conditions as regards forging stresses are stated in the paper as follows:

In our judgment, the real reason for the prejudice against steel, and for the alleged mysterious fractures occasionally noted, is due to the unequal strains set up in the material caused by unequal heating and working. In the process of forging we are putting work upon the piece, and, if this is so, no two blows are given under the same conditions. The metal is cooling slightly between each blow, so that it can be safely said no two parts have been worked alike, and the material in this form has forging strains in it. In other words, there is a different condition for every inch of length of the forging, consequently we maintain that there is just as much a necessity for relieving these forging strains as there is for relieving the strains in a complicatedly flanged throat sheet of a boiler by annealing. That is to say, the throat sheet, after flanging, and the specimen after forging, does not fairly represent the initial and intrinsic value of the steel.

The author presented a number of diagrams tending to show the effect of annealing and oil hardening upon a tensile strength an elongation of steels having from 0.28 to 1.5 carbons as compared with normal steel. These plainly indicate that oil hardening raises the tensile strength of the corresponding decrease in the elongation while annealing reduces the tensile strength with a slight increase in the elongation. The author believed that the following conclusion was warranted by his investigations:

That as the elastic limit is the factor that is taken into consideration in designing structures, such as axles or crank pins, the elastic limit being the point on which the bending stresses are based and calculated, any form of subsequent treatment

The engines are single expansion, side tank, mogul type, built to standard gauge and for burning bituminous coal. The maximum total weight is 78,600 pounds, of which 67,600 pounds are on the drivers and 11,000 pounds on the truck. The capacity of the feed water tank is 960 gallons and of the coal space one ton.

General Dimensions.

Wheel base, total, of engine.....	19 feet 0 inches
" driving	12 feet 3 inches
Length over all, engine	30 feet 1 inch
Height, center of boiler above rails.....	6 feet 2 inches
" stack above rails.....	11 feet 2½ inches
Heating surface, firebox.....	71.2 square feet
" tubes	575
" total	646.2
Grate area	12.66

Wheels and Journals.

Drivers, diameter	42 inches
" materials of centers	Cast iron
Truck wheels, diameter	28 inches
Journals, driving axle, size.....	6 by 7½ inches
" truck	4¼ by 8 inches
Main crank pin, size.....	3¾ by 4 inches

Cylinders.

Cylinders	14 by 22 inches
Piston rod, diameter	2¾ inches
Main rod, length, center to center.....	68½ inches
Steam ports, length	12 by 1¼ inches
Exhaust ports, length	12 by 2½ inches
Bridge, width	1¾ inches

Valves.

Valves, kind of	Richardson
" greatest travel	5¼ inches
" outside lap	¾ inch
" inside	3-32 inch

	Boiler.	
Boiler, type of.....	Straight top	
" working steam pressure	140 pounds	
" material in barrel	Steel	
" thickness of material in barrel.....	3/8 inch	
" " " " tube sheet.....	1/2 inch	
" diameter of barrel	46 inches	
Seams, kind of horizontal.....	Quadruple	
" " circumferential	Double	
Crown sheet stayed with.....	Radial stays	
Dome, diameter	22 inches	
	Firebox.	
Firebox, type.....	Deep	
" length	54 inches	
" width	35 "	
" depth, front	58 1/2 "	
" " back	58 1/2 "	
" material	Steel	
" thickness of sheets.....	Sides and crown, 3/8 inch	
	Back	5-16 "
	Tube	1/2 "
" Brick arch	On studs	
" mud ring, width.....	Front, 3 1/2 inches	
	Sides, 3 "	
	Back, 3 "	
" water space at top.....	Front, 3 1/2 inches	
	Sides, 4 "	
	Back, 4 "	
Grate, kind of	Rocking	
Tubes, number	122	
" outside diameter	2 inches	
" thickness	No. 13 B. W. G.	
" length	9 feet 1 inch	

AXLE LIGHTING ON THE SANTA FE.

The engravings show the application of the apparatus of the National Electric Car Lighting Company to a 4-wheel and a 6-wheel truck on the Atchison, Topeka & Santa Fe Railway, representing the equipment of 54 cars new running with this light on that road. The arrangement of the generators is similar except that the 4-wheel truck brings the machine into closer quarters than the other. We have described the apparatus of this company in our issues of February, 1897, page 56, and September of the same year, page 322.

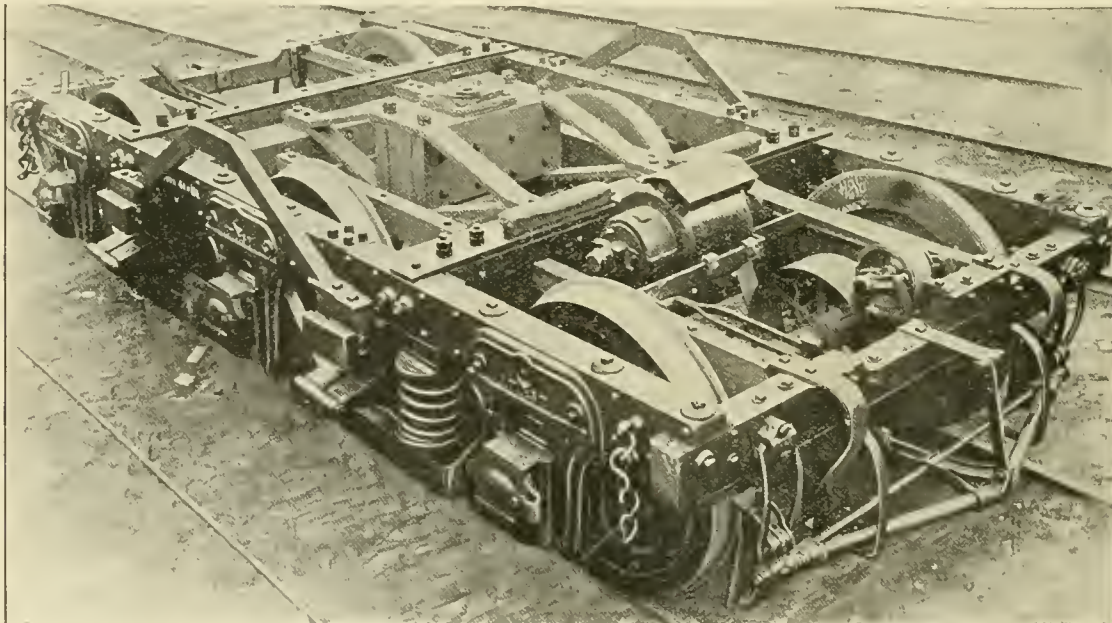

Showing Attachment of Generator to Six-Wheel Truck.

We are informed that the Santa Fe is now considering the adoption of this light on a much larger scale, and also its use for tail lights on their cars. They have also made tests with it in their Topeka yards for locomotive headlights, the intention being to equip a locomotive with one standard light installation, and besides supplying a powerful incandescent head light for the locomotive and electric light for the cab, provide also, by flexible connection, at least two of the baggage and express cars immediately behind the engine with electric light.

The three postal cars, ordered by the Santa Fe in February to be equipped with this light, are running between Chicago and Kansas City. These cars are equipped with 24 16-

candle power lights each, making a total illumination of 380 candle power. These cars stand in the Santa Fe station at Chicago every night from 6 o'clock p. m. until 2.30 a. m., burning full light. They then run to Kansas City, using full light until daylight, arriving there at 2 p. m. the following day, and start immediately on the return trip at 6.20 p. m. of the same day.

The system is now completely organized on the Santa Fe. Every employe of the train service and mechanical depart-

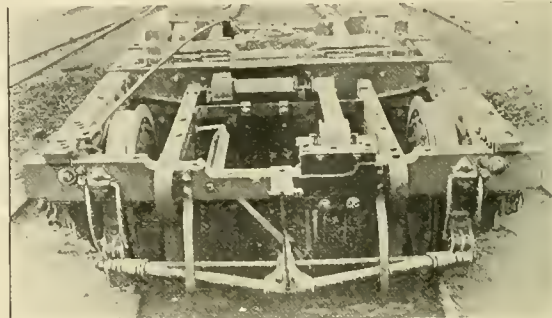

Attachment to Four-Wheel Truck.

ment has been furnished with a list of questions and answers on which he is required to pass examination. The inspectors are instructed to examine the countershaft and dynamo bearings whenever the trains are inspected, and if found hot they are required to oil them. Every car carries an extra belt of the exact dimensions required, and if one is lost in transit, the conductor is instructed to telegraph to the nearest station where extra belts are kept, and an employe of the mechanical

department replaces it, which, by means of special tools, can be done in about four minutes.

Mr. Max E. Schmidt, President of the National Electric Car Lighting Company, informs us that the company is now placing an equipment on the Long Island Railroad, and that propositions for the introduction of this light are under consideration by the St. Paul & Duluth, the Missouri Pacific, the Canadian Pacific, the Wabash and other Western railroads.

THE "PEERLESS" HOSE SPECIFICATIONS.

The following specifications for air brake hose have been prepared by the Peerless Rubber Manufacturing Company of New York, and are interesting as coming from manufacturers with a good reputation, who are prepared to fulfill the conditions:

"Each standard length of air and signal hose must be branded with the name of the manufacturer, and the year and month in which made, name of road, and a table of raised letters denoting the years and months.

"All air brake and signal hose must be soft and pliable, and not less than four-ply. The tube to be hand-made and so firmly joined to the canvas that it cannot be pulled away without breaking or splitting the tube. The tube, friction, coating and cover to be of the same quality of gum.

"All cotton duck to be used in air brake and signal hose to weigh not less than from 20 oz. to 22 oz. per yard, 35 to 40 inches wide, to be loosely woven and long fiber. Duck must be frictioned on both sides, and in addition to the friction must have a heavy coating of gum on one side, so when made up there will be a distinct layer of gum between each ply of duck. Hose without the coating will be rejected.

"The tube to be not less than 3-32 inches thick. The inside diameter of freight hose must not be more than 1 5-16 inches nor less than 1 1/4 inches. Outside diameter not more than 2 inches nor less than 1 7/8 inches. The inside diameter of passenger and signal hose must not be more than 1 1-16 inches nor less than 1 inch. Outside diameter must not be more than 1 3/4 inches nor less than 1 11-16 inches. Diameter to be as specified throughout the entire length. All short lengths to have capped ends. All caps must be vulcanized on, not pasted nor cemented on.

"The friction will be determined by the force required to unwind a section of hose 1 inch in length, the force being applied at the point of separation. With a force of 25 pounds the separation must be uniform and regular, and when unwound from outside to tube the average speed must not be greater than 12 inches in 20 minutes.

"The 1-inch section of the tube or inner lining should then be taken from the piece of 1-inch section used in the friction test, and cut at the thickest part of lap; then marks 2 inches apart will be placed on it and stretched 10 inches from the aforesaid 2-inch marks, and released immediately. It will then be re-marked, and will be stretched 10 inches, or 400 per cent., without breaking, to remain stretched 10 minutes, and to be measured 10 minutes after the strain is removed. In no case must the piece show more than 1/4 inch permanent set or elongation in 2 inches. Hose should be at least from three to seven days old before testing.

"All rejected material may be returned, the shipper paying freight both ways."

ARMSTRONG'S PIPE MACHINE WITH POWER ATTACHMENT.

The recognized merit of the No. 9 new hand pipe threading machine, the latest addition of the Armstrong Manufacturing Company to their large line of improved pipe machines, and now in general use, has created a wide demand from mills and factories for the same machine to be run by power. To

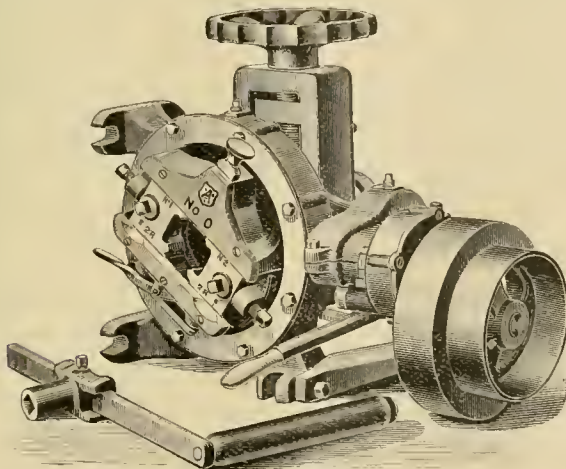

Armstrong Pipe Machine with Power Attachment.

meet the demand the Armstrong Manufacturing Company has lately brought out an attachment which can easily be fitted to the machine and turns it at once into a power machine.

This attachment is composed of an extra gear and pinion, with a two-cone pulley, which is slipped on the pinion of the second speed, and has a stay bolted on the base to support it. The engraving shows the machine with attachment ready for the belt. The No. 0 machine is made for threading pipe 1/8-inch to 2 inches and bolts from 1 inch up to 1 1/2 inches. The working parts are all encased so as to keep them free from chips and dust. The gear of the die head does not bear

on the head when revolving, and therefore does not wear loose by friction. This is considered the very latest improvement on threading machines, and is intended to make it impossible for the operator to produce a "drunken" thread.

There are other attractive and meritorious features original in this machine, and which have been made to meet the demands of those who use it. Full particulars may be obtained by addressing the manufacturers either at Bridgeport, Conn. or 139 Centre street, New York City.

THE BIG GUN FOR SANDY HOOK.

The ingot for the 16-inch gun to be constructed at the Watervliet Arsenal has been cast at South Bethlehem, and, according to the New York Sun, it will soon be shipped to the arsenal. When finished it will be mounted at Sandy Hook. The gun, which is forty-nine feet long, requires a special 100,000-pound car for its transportation. John F. Meigs, late of the navy, under whose supervision the gun is being built, says that its projectile will weigh about 2,300 pounds, and its velocity will be in the neighborhood of 2,000 feet per second. The range of such a gun would be very great, not less than ten miles, and its extreme range, or the utmost distance to which it could throw a projectile, would be in the neighborhood of fifteen miles.

The nearest approach to this distance heretofore was the so-called jubilee shot in England, where the projectile traveled twelve miles. The gun will be known as a 16-inch, will weigh 126 tons, and will cost \$120,000.

THE ADVANTAGES OF STEEL CARS.

Two typographical errors in our article under the above caption at the top of the second column of page 56 of our February issue are brought to our attention by a correspondent who read the article on "Steel Cars of Large Capacity," on page 86 of our March issue. The decimal points are misplaced. The cost per year per ton capacity for the wooden car should read \$3.61, instead of \$36.11, and the corresponding cost for steel cars should read \$2.36, instead of \$23.66. The mistake is so evident that we hope readers will not be confused by it.

EQUIPMENT AND MANUFACTURING NOTES.

LOCOMOTIVES.

The H. K. Porter Co., Pittsburg, Pa., has recently shipped two locomotives to the Great National Mexican Smelting Co. of Monterey, Mex.

The Delaware & Hudson Canal Co. has placed an order with the Dickson Locomotive Works for two mogul engines, one simple and one Dean compound.

The Rogers Locomotive Co. of Paterson, N. J., is building one locomotive for the Illinois Central and four locomotives for the Toledo, Peoria & Western.

The Richmond Locomotive & Machine Works have received the order for one compound and one simple locomotive and five spare boilers, for the Chicago Great Western.

The Brooks Locomotive Works will build the following locomotives: 30 for the Great Northern, two six-wheel switching engines for the Peoria & Pekin Union, eight locomotives for the Washington County road.

The Schenectady Locomotive Works have received orders for 20 locomotives for the Chicago & Northwestern Railway. Ten are duplicates of 18 by 24 inch, six-wheel switching engines and the others are duplicates of 19 by 26 inches 10-wheel freight engines, like those illustrated on page 407 of our issue of December, 1897. These builders also have orders for 10 19 by 24 inch 10-wheel freight engines and one 19 by 24 inch passenger engine for the Chicago, St. Paul, Minneapolis & Omaha Ry., for one locomotive for the Midland Terminal Railroad; also for 12 16 by 24 inch 8-wheel locomotives for the Kiusiu Railway of Japan, being a duplicate of a similar order received last fall.

The Baldwin Locomotive Works will build the following engines: Three for the Sorocabana & Ituana Railroad, two switching engines for the Kansas City Belt, 14 engines for the Russian State railroads, 20 for the Ribinsk-Moscow-Windau Railway, two six-wheeled switching locomotives for the Indianapolis Union, two locomotives for the West Virginia Central & Pittsburg, one six-wheel switching engine for the Cambria Iron Co., five engines for the Canadian Pacific, one en-

gine for the Kansas City, Pittsburg & Gulf, four moguls and one American type locomotive for Fort Worth & Rio Grande, one passenger engine for the Dominion Atlantic, one engine for the Florence & Cripple Creek Railroad, one switching locomotive for the National Docks Railroad, 10 10-wheel engines for the Ottawa, Arnprior & Parry Sound Railroad, and 15 heavy mogul freight engines for the Egyptian State Railways.

CARS.

The Ensign Mfg. Co. is building 150 cars for the Ohio River Railroad.

The Erie Car Works are building three cars for the Nichols Chemical Co.

The Elmira Bridge Co. will build 20 Goodwin cars for the Goodwin Car Co.

The Wells & French Co. are building 10 refrigerator cars for the Wolff Packing Co. of Topeka, Kan.

The Kansas City Car & Foundry Co. will build 100 refrigerator cars for the Armour Packing Co.

The Union Car Co. have received orders to build 100 flat and 150 box cars for the Washington County Road.

The Lima Locomotive & Machine Co. has received an order to build 500 coal cars for the Wheeling & Lake Erie.

The Haskell & Barker Car Co. are building 250 flat cars and 50 stock cars for the Chicago, Indianapolis & Louisville.

John Hamond & Co. of San Francisco will build one passenger and 40 freight cars for the McCloud River Railroad.

Rhodes, Curry & Co., Ltd., of Amhurst, N. S., are building 50 new box cars for the Intercolonial Railway of Canada.

The Ohio Falls Car Co. are building eight passenger cars for the New York, Ontario & Western, 200 coal cars and three cabooses for the Chicago & Southeastern.

The St. Charles Car Co. will build 200 stock cars of the Mather pattern for the St. Louis Southwestern, and two passenger cars for the St. Louis, Peoria & Northern.

The Missouri Car & Foundry Co. are building 150 furniture cars for the Union Pacific, 300 stock cars of the Mather pattern for the St. Louis Southwestern and 10 freight cars for the Shreveport, Red Wing & Southern.

The Michigan Peninsular Car Co. have orders for the following cars—12 for the Oahu Railroad & Land Co. of Hawaii, 500 box and 500 stock cars for the Union Pacific, 100 furniture cars for the Chicago, Rock Island & Pacific.

The Jackson & Sharp Co. of Wilmington, Del., have recently shipped five sleeping cars to Rosario for the Argentine Great Western Railroad. This concern is building one passenger car for the Narragansett Pier Railroad.

The Pullman Palace Car Co. will build two dining cars and four cafe cars for the Chicago, Rock Island & Pacific, 10 freight cars for the Richmond, Fredericksburg & Potomac, and 200 flat cars for the Kansas City, Pittsburgh & Gulf.

The Illinois Car & Equipment Co. will build the following cars: 50 60,000-lb. cars for the Mobile & Birmingham, 50 flat cars for the Kansas City, Fort Scott & Memphis, 250 box cars for the Rio Grande Western and 25 ore cars for the Spokane Falls & Northern.

MISCELLANEOUS.

The Pratt & Whitney Company of Hartford are working day and night to turn out machinery for making rapid-fire machine guns.

A new Union Station for Pittsburg is being planned. It will be on the site of the present one, and will cost \$3,000,000. The tracks will be elevated.

Messrs. Manning, Maxwell & Moore have received an order for a 72-inch Pond planer for the Davis-Egan Company. The planer will have four heads and a 40-foot table.

Magnesia Sectional Covering, furnished by the Keasbey & Mattison Co. of Ambler, Pa., was furnished for the steam motor car built by the Schenectady Locomotive Works for the Erie

Japan is reported to be about ready to order material and equipment for a large foundry to be built and operated by the government, the amount of foreign orders for which will be about \$2,250,000.

The Bushnell Manufacturing Company, manufacturers of car seats for steam, elevated, electric and cable railroads, have opened an office at 43 Cedar street New York, where all correspondence should be addressed to Mr. E. M. Bushnell, Vice-President of the company.

The Edward P. Allis Company, of Milwaukee, has an order for six vertical cross-compound condensing engines, with cylinders 46x86 in. by 60 in. stroke, for the Metropolitan Street Railway of New York. The engines will weigh about 1,000,000 pounds each, and it will require over 125 freight cars to transport the six engines to New York.

The buildings at the works of Messrs. Siemens & Halske, in Charlottenburg, Germany, occupy nearly 270,000 square feet of ground, and the number of employees is 4,000. There are 1,366 machine tools in the shops driven by shafts and belting, while 444 others are driven by direct connected electric motors. There are 472 electric motors in regular use at these works.

The Baltimore & Ohio Southwestern Railway Co. has changed its dining car system from the table d'hote to the a la carte plan with the result of increased profits, better service and greater satisfaction on the part of patrons. The cars are open for business during the entire time they are on the train, and the innovation seems to have met with the approval of the passengers.

Car curtains in the form of roller shades with a leather-like surface upon one side and a textile fabric on the other are being introduced by the Pantasote Company to replace slatted blinds. This material is impervious to moisture and not affected by rain or sponging, heat or frost. It does not fade, shrink or stretch, and is especially adapted to car seats, for which it has for a long time been used.

A belt dressing that prevents slipping and preserves the life of the leather is offered by the Joseph Dixon Crucible Co. of Jersey City, N. J. Belts are usually tightened on the first appearance of the slipping, and tight belts are known to wear rapidly. This dressing has had a good and a long record, having been used at the Paris Exposition in 1878 on the chief belt in the machinery department at that exhibition.

There are large tracts of coal lands near Meyersdale, Pa., on the Baltimore & Ohio Railroad which capitalists are beginning to develop. A new road about five miles long has been pushed into this region and will soon be ready for operation. It is one of a number of small lines that are being built by outside parties to develop hitherto inaccessible tracts of both coal and timber lands in Pennsylvania and West Virginia.

It is stated on good authority that the C., M. & St. P. Ry. will soon change certain of its suburban lines to electric traction. The Evanston division has been the subject of considerable investigation in this connection, and the plan likely to be adopted is to connect with the Northwestern Elevated, which will bring the suburban line in direct communication with the city streets by means of the Union Loop. This would be an ideal plan.

Mr. D. M. Brady, of the Brady Metal Company, informs us that his company furnished the Magnus Metal bearings for the cars and engines used in the fast newspaper train which ran from Jersey City to Buffalo over the Erie Railroad on Saturday, February 15, a distance of 425 miles, in 426 minutes of actual running time. He also states that Magnus metal is now in use on 6,827 locomotives and 235,242 cars in various parts of the world.

A new boiler, called the Paragon boiler, especially designed for yachts, tugs and canal steamers, has just been patented in the United States and Canada by Capt. M. DePuy, 19 South street, New York. Its claims are for specially good circulation and favorable arrangement of heating surface, as well as sim-

plicity of construction and accessibility for cleaning and repairs. The inventor has had a long experience with marine boilers, and has used it in this design.

The cars for the two new express trains for the Chicago, Milwaukee & St. Paul Ry., now building by the Barney & Smith Car Company, will be equipped with the Two-Coil, Jointless Steel, Fire Proof Baker Heater. Mr. Baker reports that he has just furnished 28 Single-Coil Fire Proof Heaters for the Great Northern Railroad's new cars, building by the same firm. The Louisville & Nashville, Missouri Pacific and Pennsylvania lines have also been liberal buyers of his fire proof heaters during the last few months.

The Baltimore & Ohio Railroad has purchased 10,000 tons of 80-pound steel rails for the lines west of the Ohio River. The order will be divided between the Central Ohio, the Chicago and the Lake Erie Divisions, and will make that portion of the system a fit companion for the lines east of the Ohio, which are rapidly being placed in the best shape. About 15,000 tons of the 40,000 bought last Summer for the main line will be placed in the tracks this Spring, giving the Baltimore & Ohio new rail from the Ohio River to tidewater.

The Page Woven Wire Fence Company at Ontario has recently received orders for 200 miles of fence for use on the Atlantic & Lake Superior Railway, for 42 miles on the Pembroke Southern, and for a carload for the Intercolonial Railway. The Niagara Cataract and Power Company has also ordered a carload. Beside these orders regular requisitions from railroads amount to several times as much, and the farm trade is also very large and growing rapidly. The order for the Atlantic & Lake Superior road amounts to about 30 carloads of fencing.

The Keasbey & Mattison Co., of Ambler, Pa., furnished a large amount of steam pipe covering to the Boston & Maine Railroad for the new shop plant at Concord, N. H., as described elsewhere in this issue. In this order there were coverings for 1,047 feet of 1½ inch pipe, 627 feet of 2 inch, 432 feet of 2½ inch, 780 feet of 4 inch, 534 feet of 5 inch, 792 feet of 6 inch, 111 feet of 8 inch, 6 feet of 10 inch, and 42 feet of 12 inch pipe, in all making over 4,000 linear feet of steam piping covered with "Magnesia Sectional Covering." It is doubtful whether there is a better investment than this in the entire plant.

M. Soulecroup, Assistant Superintendent of Motive Power of the Paris and New Orleans Railroad, and a corps of five assistants, have been inspecting the electrical plant of the Baltimore & Ohio Railroad at Baltimore very closely. The work being done by the electric motors in the Belt Line tunnel has attracted attention all through Europe, and M. Soulecroup's visit to this country was for the express purpose of investigating the ways and means operation. The Paris & New Orleans Railroad is to be an underground line running from one of the suburbs of Paris to the centre of the city, and it is quite probable that it will be equipped with electric motors similar to those used in the Baltimore line, except that they will be much smaller.

The increase in the business of the Sargent Company has shown such an advance over that of the first three months of last year, about 40 per cent., as to make it imperative to increase the capacity of the plant considerably. They have recently installed a large twenty-ton electric traveling crane from Manning, Maxwell & Moore, in addition to the cranes now operated, and an additional saw of the latest and most improved type, manufactured by the Q & C Co., and in their receiving and shipping departments, their capacity has been greatly increased. In the power house, new engines, dynamos, etc., are about to be installed. The works now have a capacity of about 1,000 tons a month, which will, of course, be greatly increased by the changes now in process.

Thirty-one thousand tons of steel rail, ranging in weight from 75 to 85 lbs. to the yard, will be placed in the B. & O. tracks this spring. It is expected that the work will begin by April 1 and be completed within three months. Twenty-one thousand tons will be laid east of the Ohio River, and forms

part of the 40,000 tons purchased last Summer, the balance being the 10,000-ton lot recently bought by the receivers for west of the Ohio River. This new rail will be laid on divisions where the traffic is very heavy. It has been found that about 60 per cent. of the old road is in good condition for portions of the line where light rolling stock is used, and it will be used to replace the rail now in service on these parts of the road. When all this rail is laid there will be a new double track from Grafton to Baltimore.

In a set of rules or specifications for steam piping recently compiled by the mechanical engineer of a large railroad system for the guidance of those who install such works on the road, the following occurs: "Use only best grades of packing. We are using 'Rainbow,' which is undoubtedly the best." These specifications were intended only for use by men on the road, but a representative of this paper was allowed to see them. "Rainbow" packing was described on page 335 of our issue of October, 1897, in connection with other products of the works of the Peerless Rubber Manufacturing Company, who manufacture this packing. "Rainbow" packing was used on all the flange connections in the extensive piping system at the Concord shops of the Boston & Maine R. R., of which a description is given elsewhere in this issue.

The Baltimore & Ohio Railroad Company has improved its freight facilities in Philadelphia very materially during the past year. A new pier, known as No. 22 South, which was completed last December, is 557 feet long and 140 feet wide, and is said to be one of the finest in the city. Vessels of the deepest draught can tie up on both sides of the pier, thereby affording every facility for the prompt handling of freight. The pier and sheds are lighted with improved incandescent lights, and well-paved driveways have been provided. This improvement enables the B. & O. to handle about three times as much business as formerly. The different freight yards throughout the city have been improved by the laying of additional tracks, and arrangements have been made with the Pennsylvania Warehousing and Safe Deposit Company by which the B. & O. handles grain, flour, hay, straw, canned goods, and other merchandise, through their warehouses and elevators.

O'Neill Brothers, manufacturers of wool waste, Columbia avenue and Putnam street, Philadelphia, in noting the article on "Lubrication of Driving Journals," on page 97 of our March issue, call our attention to the importance of using good packing in journal boxes. Many railroads pay too little attention to this, and it is believed that much of the trouble with hot boxes may be avoided by improvement in this direction. We have been allowed to see the following letter, written to Messrs. O'Neill by a prominent railroad man, whose name we are not at liberty to print: "Referring to your letter of 23d ult. following report from our Master Mechanic concerning wool waste furnished by you: 'Replying to your favor of November 29th, and returning herewith all correspondence, beg to advise that the wool waste received recently from O'Neill Brothers, of Philadelphia, is at present giving good satisfaction. We have used part of it in our passenger coaches and some on our engines, and it has given no trouble at all.'"

The Pancoast Ventilator Company, Philadelphia, writes that since they have equipped the West Virginia, Central & Pittsburgh, Cumberland, Md., round-house with their ventilators, or smokestacks, they have had a large number of requests from prominent railroad officials for information and tracings that will show their improved device. It has proved so satisfactory to the above company that Mr. Hervis, the president, has been requested by a prominent chief engineer to visit the round-houses of his road, with the view of having the "Pancoast" used in the place of a large number of so-called ventilators now in use on their buildings, stating that the damage to locomotives in a year will pay for ventilators of a proper kind many times over. We are glad that this important matter is being appreciated. Round-house smokestacks will form the subject of an investigation and report by a committee of the Association of Railway Superintendents of Bridges and Buildings at the next meeting, to be held at Richmond, Va., Oct. 18, 1898.

The Bacon Air Lift Company, until recently with the Blake Pump Manufacturing Company, Liberty St., New York, is now occupying very handsome offices on the twentieth floor of the American Surety Building, 100 Broadway. The change was made necessary by the rapidly increasing business. Among the men prominently identified with the company are: Mr. J. E. Bacon, who has made a special study of water supply problems for several years, during which time he has had occasion to inspect and install a large number of air-lift pumps; Mr. George R. Young, who for a long time was identified with the Knowles Steam Pump Works, and who is possessed of a practical knowledge and experience in the matter of pumping systems; Mr. John T. Gibson, late of the Blake Manufacturing Company, a specialist in all classes of pumping machinery. Mr. Clifford Shaw is to superintend the construction department, and is fitted for the work by a wide experience. The company has secured the patents of Mr. Young and Mr. Shaw, which cover valuable improvements in air-lift pumps, greatly increasing the field in which such pumps may be used, and lessening the cost of operation considerably.

Our Directory

OF OFFICIAL CHANGES IN MARCH.

Aransas Harbor Terminal.—Chief Engineer W. D. Jenkins has moved his office from Tarpon, Tex., to Aransas Pass, Tex.

Chicago, Burlington & Quincy.—Mr. George G. Yeomans has been appointed Purchasing Agent, with headquarters at Chicago, Ill., to succeed Mr. George Hargreaves, resigned.

Chicago Junction.—Mr. F. T. Craxow has been appointed Purchasing Agent.

Choctaw, Oklahoma & Gulf.—Mr. James Cunningham, Master Mechanic, has transferred his office from South McAllister to Shawnee, I. T.

Cincinnati Northern.—Mr. Frank B. Drake has resigned as General Manager, and the office has been abolished.

Cleveland, Cincinnati, Chicago & St. Louis.—Mr. A. M. Stimson, Purchasing Agent, died at his home in Lafayette, Ind., March 8, after a brief illness.

Columbia & Western.—Mr. T. G. Shaughnessy, Vice-President of the Canadian Pacific, has been elected President of the Columbia & Western.

Connecticut River.—Mr. John Mulligan, President of this road, died at his home in Springfield, Mass., February 21, at the age of 78 years.

Cornwall.—Mr. C. G. Herman of Philadelphia, Pa., has been appointed Master Mechanic, with headquarters at Lebanon, Pa., succeeding Mr. A. J. Reed. Mr. Herman was formerly with the Baldwin Locomotive Works.

Detroit & Lima Northern.—Mr. A. Mitchell, who has been Chief Engineer in charge of the extension of this road, has resigned, and is succeeded by Mr. Frank Mitchell.

East Tennessee & Western North Carolina Railroad.—Mr. R. F. Hoke is President and Mr. F. Firmstone Vice-President of this company.

Findlay, Ft. Wayne & Western.—Mr. C. M. Bissell, General Manager of this road, is reported to have tendered his resignation, to take effect April 1.

Fonda, Johnstown & Gloversville.—Mr. James Pierson Argeringer, Director and Vice-President, died at his home in Johnstown, N. Y., March 11, at the age of 64.

Fort Worth & Denver City.—Col. Morgan Jones, heretofore Vice-President, has been elected Vice-President and General Manager.

Fulton County Narrow Gauge.—Mr. W. G. Sharretts has been appointed Superintendent, with headquarters at Lewistown, Ill., in place of Mr. A. C. Atherton, resigned.

Hutchinson & Southern.—This road has been reorganized and Mr. W. A. Bradford, Jr., formerly General Manager, has been elected President. Mr. L. E. Walker, formerly Receiver, has been elected Vice-President and General Manager.

Kansas City, Watkins & Gulf.—Mr. H. B. Kane has been appointed Receiver, with office at Lake Charles, La.

Leavenworth, Kansas & Western.—Mr. B. R. Brandow of Leavenworth, Kan., has been appointed Master Mechanic. His office will be located at Leavenworth, Kan.

Lebanon, Sodaville & Waterloo.—Mr. M. W. Wilkins of Waterloo, Ore., is President and General Manager.

Lehigh Valley.—The General Traffic Offices, now at Philadelphia, will be transferred on May 1 to New York City. Offices will be opened in the Havemeyer Building, in Cortlandt street. Mr. E. P. Mooney has been appointed Master Mechanic of the Buffalo Division, with headquarters at Buffalo, N. Y., succeeding Mr. John Campbell, recently resigned. Mr. Mooney has been acting as Road Foreman of Engines and Traveling Engineer of the Buffalo Division for six years. Mr. Alvin C. Smith of Buffalo has been appointed to succeed Mr. Mooney.

Lehigh Valley.—Mr. Robert H. Sayre has been appointed Assistant to the President. He was formerly Second Vice-Presi-

dent of this road. Mr. J. B. Garrett has been appointed Second Vice-President. He was formerly Third Vice-President.

Minneapolis & St. Louis.—Mr. Howard G. Kelley has been appointed Chief Engineer, with headquarters at Minneapolis, Minn. He was formerly Chief Engineer of the St. Louis Southwestern.

Mississippi River, Hamburg & Western.—Mr. A. M. Gibson has been appointed Chief Engineer, with headquarters at Portland, Ark.

Mobile & Ohio.—Mr. E. L. Russell has been chosen President; he was formerly First Vice-President. He succeeds Mr. James C. Clarke, resigned. Mr. Richard Carroll has been appointed Vice-President and General Manager, succeeding Mr. J. G. Mann as General Manager, Mr. Mann having been appointed Chief Engineer. Mr. W. A. Stone has been appointed Master Mechanic of the Montgomery Division of this road. He was formerly Master Mechanic of the Southern Railway at Selma.

New York, New Haven & Hartford.—Mr. F. B. Smith, who has heretofore had the title of Master Mechanic, has been given the title of General Master Mechanic. His headquarters are at New Haven, Conn.

Pacific Coast.—Mr. H. H. Durand has been elected President and Mr. Wm. H. Porter has been elected Vice-President, with headquarters at New York.

Omaha, Kansas City & Eastern.—Mr. W. A. Williams has been appointed General Superintendent, with headquarters at Quincy, Ill. He was formerly Superintendent of the Northern Division of the Kansas City, Pittsburg & Gulf.

Peoria & Pekin Union.—At the annual election held at Peoria, Ill., March 8, Mr. George L. Bradbury, Vice-President and General Manager of the Lake Erie & Western, was elected President and General Manager of the Peoria & Pekin Union. Mr. C. H. Bosworth was elected Vice-President and General Superintendent, with office at Peoria, Ill.

Rome & Carrollton.—Mr. C. B. Wilburn has been appointed Receiver. He is also President of the Chattanooga, Rome & Southern.

Santa Fe Pacific.—Mr. Richard English has resigned as General Master Mechanic.

Seattle & International.—Mr. L. S. Miller has been appointed Assistant to the President, with headquarters at Seattle, Wash. He was formerly Assistant General Manager of the St. Paul & Duluth.

Southwestern Alabama Railway.—Mr. S. G. McLendon has been elected President, with office at Thomasville, Ga.

St. Louis Southwestern Railway.—Mr. H. G. Kelley has resigned as Chief Engineer, and the office has been abolished.

St. Louis, Avoyelles & Southwestern.—Mr. W. H. Peterman has been appointed Receiver. He was formerly President of this road.

St. Paul & Duluth.—Mr. C. J. A. Morris has been appointed Chief Engineer, with headquarters at St. Paul, Minn. Mr. Morris has heretofore been Chief Engineer of the Northwestern Coal Railway at St. Paul.

Tacoma & Columbia River.—Mr. W. C. Halliday has been appointed Chief Engineer, with headquarters at Tacoma, Wash.

Texas Central.—Mr. Richard Oliver, Secretary and Treasurer, has also been appointed General Manager, vice Mr. Charles Hamilton, who still continues as Vice-President.

Union Pacific.—Mr. T. A. Davies, Master Mechanic of the Wyoming Division of this road, has removed his office from Laramie to Cheyenne, Wyo.

Walterboro & Western.—Mr. C. S. Gadsden has been elected President.

Washington & Columbia River.—Mr. Joseph McCabe, formerly Superintendent of the Pacific Division at Tacoma, Wash., has been appointed General Manager, with headquarters at Walla Walla, Wash., succeeding Mr. W. D. Tyler, recently resigned.

Wilkesbarre & Northern.—Mr. John Graham of Philadelphia, Pa., was elected President and General Manager, succeeding Mr. John B. Reynolds of Kingston, resigned.

Wiscasset & Quebec.—Mr. W. Fred P. Fogg has resigned as General Manager, and Mr. William D. Patterson, Treasurer, has been appointed Acting General Manager, with headquarters at Wiscasset, Me.

WANTED.

A capable locomotive draftsman for a railroad position. Applicants must have good training in theory and some years of experience in drawing office on locomotive work, shop experience very desirable. A promising position for an industrious and capable man. Address "Draftsman," care American Engineer, 140 Nassau St., N. Y.

WANTED.

A practical car draftsman, capable of working out details of freight cars and making finished drawings of all kinds of freight equipment. State age, experience and salary expected. Address X. Y. Z., care American Engineer, 140 Nassau St., N. Y.

AMERICAN ENGINEER

CAR BUILDER AND RAILROAD JOURNAL.

MAY, 1898.

CONTENTS.

ILLUSTRATED ARTICLES:	Page	MISCELLANEOUS ARTICLES:	Page
Railroads in China.....	115	Electricity in English Shops.....	152
Construction of a Modern Locomotive.....	117	New Rules for Marine Boilers.....	152
Freight Trucks, L. & N. Railway.....	153	Ship Canal—Black and Baltic Seas.....	158
Locomotive Design—Crank Pins.....	153	Electric Cranes vs. Transfer Tables.....	159
Boiler Steel Ingots.....	155	Baldwin Locomotives for China.....	160
Hollow Driving Axles and Crank Pins.....	156	Draftsmen from Technical Schools.....	160
The "Kentucky" and "Kearsarge".....	157	Railroad Club Reports.....	161
Adjustable Journal Bearing Keys.....	158	Engineering Notes.....	161
Key Ways in Driving Axles.....	161	Monitors vs. Battleships.....	165
The Holland Submarine Boat.....	163	Philadelphia and Reading, Shop Notes.....	169
Consolidation Locomotive, C. C. C. & St. L. Railway.....	167	Automatic Couplers.....	173
Ingersoll-Sergeant Air Compressors.....	168	Electrical Equipment, Boston Union Station.....	173
Aerme Heading and Forging Machine.....	174	Boiler and Steam Pipe Lagging.....	174
Schmidt Superheating System.....	172	EDITORIALS:	
Apparatus for Testing Air Hose.....	175	Drop Tests for Couplers.....	162
New Cars by the J. G. Brill Co.....	176	Balanced Valves for Locomotives.....	162
		Chinese Railroads.....	162
		The Cleaning of Triple Valves.....	162
		More Light on the Compound Locomotive.....	163

THE RAILWAYS OF CHINA, EXISTING AND PROSPECTIVE.

By Andrei Kmita.

[Peking, January 31, 1898.]

The existing railways of China, compared with those projected, are as the good things done to those left undone. The railways in operation extend from Tientsin to Tong-Ku, the actual seaport, and from Tong-Ku to Shan-Hai-Kwan, where it passes through the "great wall" and north 30 miles into Mongolia. The length is 210 miles. This line has been in operation for a number of years, and if the Chinese Directors would allow the foreign employees to manage it, would be a well paying line. Northwest from Tientsin is the railway to Peking 80 miles in length. This line has been in operation seven months, and as yet it has but a single track. The traffic, both in freight and passengers, is so great that, despite Chinese Directors, this line is to-day one of the best paying railways in the world. From the junction near Peking the first section of the Peking-Hankow Railway is about completed to Paoting. There is a short railway of 12 miles from Shanghai to Wu-Sung nearly completed. The work on this line commenced about the same time as the work on the Tientsin-Peking line, but as yet no trains are running.

This completes the list of existing railways. With the exception of the Wu-Sung line they are all Imperial Chinese railways, and are practically owned and operated by the Imperial Government. They have all been built under the direction of English engineers and the design and manner of execution of the work is most excellent. The Chief Engineer, Mr. C. W. Kinder, has been in Chinese employ some fifteen years and his work shows a careful study of the special conditions that obtain here and the best methods of satisfying them. The rolling stock is of the American type, the locomotives for the Tientsin-Pekin line and the Peking-Paoting line are all American. This entire line is upon the flat alluvial plain and any engineering difficulties encountered are in the construction of flood opens and not in the location of the line. The entire design of the road and equipment is a combination of American and English practice that appears best suited to this country. The Wu-Sung line is under German engineers, but the locomotives contracted for are American.

In regard to the prospective railways of China, we will commence at the north with the continuation of the Russian Trans-Siberian Railway across Chinese territory to Vladivostok. The Chinese granted permission for the construction of this line in a secret treaty, arranged and signed in Peking by the Russian Minister, Count Cassini. The alleged reason of the Russian desire was a more direct route to Vladivostok. The distance saved is about 200 miles, but the country passed over is exceedingly rough in parts and the cost of construction will be great. Manchuria is exceedingly rich in all food stuffs for men and cattle. Russia must have these to support her Siberian population and army, and a railway through the heart of the province gives her absolute control. This line bears the title of "The Chinese Eastern Railway Company." It is ostensibly a Chinese railway, but located and constructed under Russian engineers, paid for by Russian money and when finished will be entirely under Russian control. This road is financed by the Russo-Chinese Bank, with headquarters at Peking and branches at many of the open ports. The capital of this bank is entirely European and not one share is owned by a Chinaman. The Russians have the right to station their troops in Kirin and at every town along the proposed railway. All of the engineers have Cossack guards and Russia is allowed to protect her subjects in this part of China with her own soldiers and without regard to Chinese officials. The attitude of Chinese officialdom to Russia is disgustingly abject. The directors, superintendents, engineers, bank managers, clerks and soldiers are all Russian. The office boys, house coolies and servants are Chinese. Such is a Russo-Chinese combination. The Chinese people welcome the change. Any master is better than the mandarin.

None of this line is as yet constructed and but a slight portion finally located. Engineers, however, are at work on every section and a few years will see it completed. Russian engineers are locating the railway from Kirin through Murkden and Neuchwang to Port Arthur. The Russians now occupy Port Arthur and are preparing to rebuild it for the Chinese. It will be rebuilt with Russian money, under Russian engineers, and in accordance with Russian designs. Russia will then undoubtedly guard it for the Chinese.

It may be of interest to know that the Russian troops in Siberia are so stationed, that by two weeks' easy marches, over one hundred thousand can be concentrated at Kirin. This will become necessary for the protection of China if her autonomy is threatened by a foreign power. Autonomy may here be defined as the right of China to govern herself in accordance with Russian specifications.

The Imperial Chinese railways will be continued north to some point beyond Kin-Chou, where a connection with the Russian system will be made. Some change will then be necessary, as the Chinese system is 4 feet 8½ inches in gauge, while the Russian system is 5 feet.

A projected line upon which some preliminary work has been done extends from Peking through Kalgan and Kiakhta to Verkhniudinsk on the Trans-Siberian Railway. This line follows, more or less, the present caravan route, over which, each year, hundreds of thousands of camels transport tea to Siberia and return with wool, camel's hair and furs. The traffic over this line would be important, and unless a check is put upon Russian influence there will be another Russo-Chinese combination railway company.

The Peking-Hankow-Canton Railway will be the great trunk line of China. Nearly every syndicate that has been represented in China during the last fifteen years has made an effort to secure this line. A New York syndicate had a representative here for over two years working for the north half of this railway, Peking to Hankow. No agreement was possible between the Chinese and the syndicate and the representative was withdrawn. The methods of negotiation used, while possibly correct in the United States, were not at all so when dealing with the Chinese in China, and until Americans make

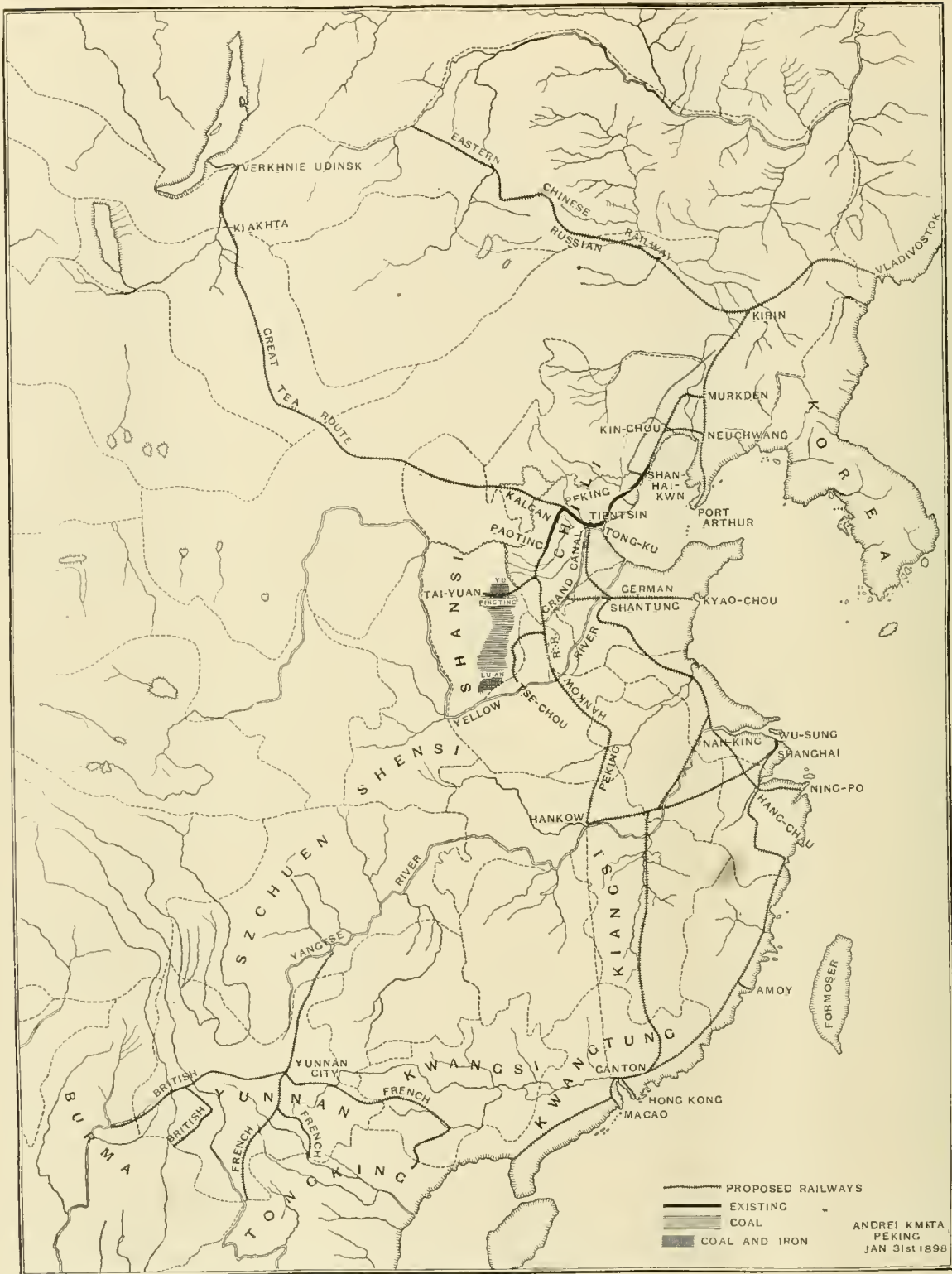

The Railways of China, Existing and Prospective.

the necessary modifications in their methods and appreciate the fact that they are soliciting a favor, not conferring one, none of the large industrial enterprises in China will be given to American syndicates.

Last summer a contract was signed between the Chinese and a so-called Belgian syndicate by the terms of which the syndicate agreed to furnish £4,500,000 for the construction of the Peking-Hankow Railway. The contract gave the syndicate but a small rate of interest, 4.4 per cent., and no perceptible security for their money. The first payment to the Chinese of £1,012,500 was due January 3d, 1898. No payment was made at that time or since. The Belgian Minister says there

is only a temporary delay. The Chinese authorities say that the contract is null and void. Who knows?

The Hankow-Canton line has as yet been secured by no syndicate, although it has been on the market for two years. The reason the Chinese have not come to some permanent agreement with some responsible foreign syndicate is that the business methods of H. E., the Chinese Director General of Railways, are not considered sound from a European standpoint, and also the fact that there are so many self-styled representatives of prospective syndicates in the field it is difficult to distinguish the chaff from the grain. Much of the chaff, however, is disappearing before the wind of daily ex-

penses. One of the most important concessions is for the Tientsin-Shanghai line running through the Province of Shantung and down the coast. This is being negotiated for by a Chinaman who has lived many years in the United States and he is promised financial aid by a New York syndicate that now has an agent on the way to China. In view of the preliminary requirements demanded by previous American syndicates it is doubtful whether any final arrangement will be possible.

The Shanghai-Nanking-Hankow line, following more or less the course of the Yangtze River, and the direct Shanghai line, are both asked for by various parties. Both lines run through an immensely rich agricultural country swarming with people. But either line must divide the traffic with the river steamers. The short line from Shanghai through Hang-Chau to Ningpo probably has more people to the mile than any proposed railway in China. The population along this line runs up to several millions. The coast line from Shanghai to Canton runs through the rich tea and rice country. Another Canton line comes down the center of Kiangsi with its millions of people. Southwest from Canton is a proposed line in the direction of Tongking. This completes the proposed railway system of Eastern China.

With the exception of the Russo-Chinese line the right of construction of none of the proposed railways has been granted to a foreign syndicate. The financially sound companies in the field are few, and all of this work must be paid for with foreign capital. No Chinaman will subscribe one cent as long as the management is in the hands of the mandarins, and yet China must have these railways soon in order to increase her revenues, and there is not one of these proposed lines but what would prove a good investment.

Returning to the north of China. The Germans will at once build a railway across the Province of Shantung from their new port of Kyao-Chou to some point on the Grand Canal. This is not the result of an agreement between the Chinese Railway Administration and a foreign syndicate, but the result of a German-Chinese combination in which Germany holds all of the votes.

The only concession to a foreign syndicate that has been signed and ratified, and upon which actual work has been done, is the "concession in perpetuity" of all rights for working the coal and iron deposits in the Province of Shansi and the right to construct and operate all railways necessary for placing the products of these mines on the market. The Province of Shansi has an area of 90,000 square miles. It is surrounded on all sides by mountains and has an interior plateau some 3,000 feet above the sea. The coal deposits in this province exceed in extent, quality and continuity any fields the civilized world has yet seen. Baron von Richthofen, the greatest authority upon the geology of China, gives the area of unbroken coal strata in Shansi at about fourteen thousand square miles. The writer of this has examined an area of over 200 miles long and 30 miles wide. Over this entire area the continuity of the coal strata was unbroken and at any point there is workable coal of over 30 feet in thickness. This statement is not made from a mere examination of surface indications, but from examinations of hundreds of native mines.

In two sections at least in this coal area, Ping-ting to Yu and Tse-chou to Su-an, there is associated with this coal deposit a wonderfully pure iron ore, brown hematite and spathic. A railway will be built from each of these iron centers to the alluvial plain of Chili. Both of the lines terminate not only upon the Peking-Hankow Railway, but upon water-ways navigable to the sea by the way of Tientsin. Considering the great scarcity of coal in China and the poor quality of the Japanese coal, the opening of these mines will certainly create something of a revolution in the coal markets of the world. The small native iron furnaces turn out each year some tens of thousands of tons of manufactured iron, and what an immense effect upon trade modern methods on a large scale will have can be imagined. The preliminary surveys have been made and at present an American mining engineer is in the

field to locate the works. The actual work will begin in April. This concession of mines and railways will be more far-reaching in its effects upon the world's industrial economies than any other concession asked for.

Turning to the Southwest of China and the Province of Yunnan, we see some proposed lines of what we may call political railways. Yunnan is said to be very rich in all mineral deposits. It is a province little known and exceedingly rough and mountainous. One the west is British Burma, on the south French Tongking. Both England and France wish to run through Yunnan to Yunnan City and thence north to some point on the navigable waters of the Yangtse. These desires cause much diplomatic wire pulling in Peking. The French claim that their convention is signed, the Chinese deny it; England makes the concession of these Yunnan railways one of the conditions upon which she will lend China sixteen million pounds. Russia insists that China must use only Russian money, etc. What are the actual facts in the case "Is one of those things that no fellow can find out, for when two or three are gathered together in the name of diplomacy there the Devil is in the midst of them."

China is going to be opened to the world—not from any desire on the part of China, but from sheer necessity. China must have foreign capital to enable her to remain intact. To procure this capital she must exploit her resources. She must submit to the inevitable and open her country to foreign enterprise and methods, or the surgical operation of dismemberment will be performed.

THE CONSTRUCTION OF A MODERN LOCOMOTIVE.*

III.

By Motive Power.

Schedule of Work.—For the purpose of facilitating output and economy of time, it is essential that not only the capacity of each particular department, but the order in which material will be required in each one of the departments, shall be known, and it is understood that all of the departments outside of the erecting are contributive in finished or partly finished material used in final erection.

Experience has shown that the arrangement of gangs and divisions of work in the erecting shop, also the relative time required for the erection of work included in certain sub-divisions in this shop, can be taken as a guide or schedule for the furnishing of the various parts required in this erection, and this schedule used as a guide by other departments, informing them of the order in which the various parts specified on it should be gotten out and delivered to the erecting shop. The same schedule is given to all departments, for the reason that some, if not all of the parts included on it have work done on them in the various departments. This schedule is not intended to cover all of the parts in detail required for the complete locomotive, but rather to give a fairly accurate and general idea of them, and their various groupings, conforming to the division of the work in the erecting shop on the lines above mentioned. For instance: The frame work is done entirely by one or more gangs, and may include any convenient groupings of parts. Considering it to include all of the work on the frames necessary to make ready for the mounting of the boiler, and equipped with cylinders, guide yoke, rocker boxes, rockers, lift shaft and bearing, stiffening pieces, pedestal caps, foot plates, cross braces, front and back end castings, etc., the schedule will mention these various parts, which will be grouped, by means of brackets, into sub-divisions, and each one of these sub-divisions designated by numbers intended to indicate the order in which they shall be required by or delivered to the erecting shop.

The grand divisions of the detail schedule of parts required for the engines may be designated by capital letters, and need

* For previous article see page 116.

not comprise more than six or seven such divisions. For instance: Frame work may be known by the letter "A" and contain in its grouping the cylinders, rockers, etc., as above instanced; "B" may be understood to indicate the boiler, with all of its mountings prepared for mounting on the frames; "C" the general erection, and including such parts as will be required in the general erection; "D" air brake and driver brake work; "E" tank work, and so on. In fact, these divisions can be made to suit the peculiar requirements of the plant or the individual taste of the management, the main object being to provide a universal schedule for the governing of all departments contributing parts to the erecting shop, and in such a way that these parts will be gotten out in their required order, without unnecessary confusion and delay, also controlling the movement of the work through the various departments on time and in time for the economical and prompt completion of that order of engines.

It will also be obvious that these schedules may be used as a guide in the specification as to the time of delivery of raw material, and will prevent the unnecessary accumulation of such material to a larger extent in one month than would represent the consumption of the plant, avoiding excessive balances in stock accounts and unnecessary investment, also acting as a guide for the starting of a very large amount of work on the order for engines in various departments where certain kinds of stock material are carried, and enable a very large amount of work to be done systematically, and to great advantage, pending the arrival of material on order.

The very careful supervision of this or the more thorough adoption of a scheme of this kind, or some satisfactory modification of it, in plants where the equipment would apparently be below the requirements of output, will in many cases, without additional investment, bring about a larger output with the original installation, enabling departments which are apparently weak in facilities to start long enough before the time required for the delivery of material in producing their output to anticipate the largest demands made on them.

Testing.—There can be no question of the advantage of a systematic and thorough method for the proper testing of all the material used in the construction of a modern locomotive, and having this department located at the works where the construction is carried on. Not only does a department of this kind act as a check on the use of poor or defective material, but it facilitates the keeping of accurate records of kinds of material used in any particular form of construction, which, if properly kept, may be used as a reference and referred to as a history of not only the poorest, but the best material for construction of this class of machinery. The records of performance in actual service of this kind of material, where possible, should also be kept in this department.

Boiler Shop.

Generally speaking, and of course controlled, to some extent, by the capacity of these departments, the boiler and blacksmith shops will have to lead on the first work on an order for engines, and commence work on them before the other departments.

Higher steam pressures and more severe service, independent of designs, have had a very material effect on methods of boiler construction, and in no one part of the locomotive should more pains be taken, not only in the general, but detailed construction.

The general arrangement of facilities and the method of handling work in this shop should be such that the stages of progress from raw material to the finished boiler would be continuous and progressive from the point of delivery of raw material at one end of the shop to the completion and exit of the finished boiler at the opposite end. Retrograde movement in the handling of work should by all means be avoided, and special attention should be given to appliances which will reduce the actual cost of labor of handling.

In a general way, the work in this shop may be divided into

the following divisions: The laying off and templet work; punching, shearing and planing; flanging; fitting up and riveting; and flue work.

Depending, of course, upon conditions, size of plant, etc., the boiler work may include all of the tank work, pipe and sheet iron work, as well as coppersmith work, and it is convenient, with an arrangement of this kind, to have it all under the direct charge of one foreman, with such gang foremen in charge of convenient sub-divisions as may be necessary. The work of laying off should be done by a man capable in every way, and well able to read and interpret drawings, whose work will act as a very valuable check against any errors which may be made in the drawings.

The question of drilled or punched holes and holes punched before and after sheets are bent, has been discussed fully from time to time, and each of these methods has both good and bad points. The recent construction of machinery adapted to the drilling of holes after the sheets are bent will no doubt in many cases be preferred as giving better results, especially on very heavy sheets, than where the holes are punched smaller than required when the sheets are flat, and reamed to size after the sheets are bent. We have, however, seen very excellent results on high pressure boilers by this latter method, and do not think there is any serious question of the strength of the bridging between the holes where the punched holes are small enough to allow a margin for the reaming out of the distressed material around the edges of the holes. The fin left on punched holes, especially where the sheets are to be bent and the fin side of the hole would come on the outside of the curve, should by all means be removed. We have known of cases where the sheets have cracked in the bridging, due to this cause alone, the thin edge of the fin presenting a hard, sharp surface which is readily fractured with the stretching of the outside of the sheet, due to bending; and have also known cases where fire box side sheets of perfectly satisfactory material have been condemned as poor material; whereas, the real cause for the cracking was due to the fins referred to, and tests made with the fins removed on the same kind of material did not in any way show the slightest sign of fracture.

The edges of all sheets which are to be calked after being in place, wherever possible, should be planed at a sufficient angle with the flat surface of the sheet to give a satisfactory amount of metal for tucking up without the danger of springing the sheet away from its mate.

Flanging.

Where properly and intelligently handled, there is no question of the advantage of machine over hand flanging. The press for this purpose should be of at least 300 tons capacity, and in addition to the main ram for raising the table, should be provided with a center ram telescoping in this main ram, four auxiliary or jack rams, and also a ram working from the top platen downward. It will also be found convenient to have portable side cylinders, which can be bolted on the lower table for side clamping on such work as the flanging of certain kinds of throat or connecting sheets.

The substitution of machine flanging, in one or two operations, with full size dies, in this country, at least, is comparatively new, only having been more or less commonly adopted within the last few years. At the time of the writer's first experience with this character of work there were probably not more than two machines of the particular type with which he had to do in this country, and the information, data, etc., in connection with the designing of the dies, their use and proper allowances to be made, was decidedly meagre. A careful research failed to discover in any of the known publications information which could be used as a guide, and as the result of a great number of experiments, covering a period of several years, we give for the benefit of those who may be seeking information of this kind, a set of formulae, which are generally applicable to this class of work, being particularly connected with flanging, i. e., where the metal is turned up around a former. We make this distinction as between metal

formed in this way and that drawn through a ring, which is commonly known as "drawn" work. This formula has been repeatedly tested in the practical designing of dies for a wide range of work and found perfectly satisfactory.

In cases of doubt connected with the forming or flanging of difficult sheets, a small set of dies, made to a scale size, of hard wood, and used to flange a piece of sheet lead, of also a proportionate scale thickness to the full size sheet, has been found very satisfactory, and owing to the fact that annealed sheet lead, in its action, is analogous to a sheet of boiler steel of full size heated to 1,700 to 1,900 deg. F., the action of the

and rather slow heat. The method of delivery of the heat to the bed of the furnace, in which the sheet is placed, should be such that no one portion of a sheet can become overheated by reason of flame contact. In color the heat should be not exceeding a bright cherry, and in temperature it may range from 1,700 to 1,900 deg. F., according to the character of the flanging.

Before flanging the first sheet, the dies should be heated up, so that their proper expansion, which is provided for in the formula referred to above, may take place, and the sheets, when cool will be of the proper size. A common method of

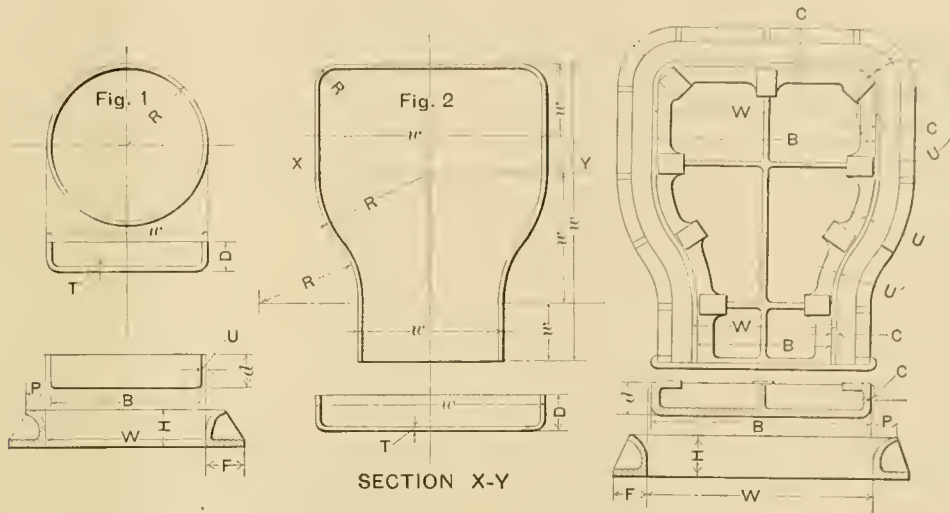

Values of letters used in formulæ :
 w = Size of flanged sheet or any portion of it when cold.
 D = Depth of flange when cold.
 R = Radius to outside of flange when cold.
 T = Thickness of sheet when cold.
 W = Size of female die when cold.
 B = Size of male die when cold.
 C = Clearance between male and female dies when straight and when cold.
 U = Clearance when curved and edge upset.
 U' = Same when stretched.
 S = .0078" per inch allowance for contraction of sheet.
 All dimensions in inches or decimals of an inch.
 For general proportions of male and female dies:
 H = 2.1 D; F = 2.1 D; P = 1.2 D and d = 1.5 D.

Then for Fig. 1:
 $W = wS + w$ and
 $B = W - \left(\frac{D \times .1298}{R} \right) + 2.1T = W - 2U.$
 $U = \left(\frac{D \times .0649}{R} \right) + 1.2T.$
 $U' = 1.2T - \left(\frac{D \times .0649}{R} \right)$
 For Fig. 2: $W = wS + w$ and
 $B = W - (1.2T \times 2).$
 $C = 1.2T.$

Note. - For ordinary practice and for radii not less than 3" or more than 15" and when "D" does not exceed 4" - "U" can = 1.27T. The female die decides size of sheet and all allowance for clearance must be made on male die.

Formulæ for Dies for Flanging Sheet Steel.

lead in these dies can be taken as a guide indicating the action of the full size sheet in regularly designed dies for a similar shape. The stretching or upsetting action of the piece of lead used as an illustration in these small dies can be very readily noted if the sheets when flat, and before being formed are laid off in small squares of some convenient size. The distortion of these squares after the flanging of the model sheet will graphically indicate the distortion of the metal, and will be analogous to what will occur in the full size sheet in regularly designed dies.

The flanging press should be located in front of the furnace, with a sufficient space between it and the furnace to allow of a generous sized iron straightening floor. Convenient lifting facilities should be provided for handling the dies, and also, in the case of heavy sheets, an overhead rail or some satisfactory form of quick moving crane for handling the sheets from the furnace to the press, it being important to place the sheet in the dies as quickly as possible after it leaves the furnace, for the best results.

The furnace should be provided with a level, flat floor, preferably of fire brick, and may be heated by either coal, burned in a separate regenerative chamber, producer gas or oil. The construction should be such as to provide an evenly distributed

doing this is to heat the first sheet and place it on the dies without flanging until the dies become sufficiently hot. Between the operations of flanging the dies should be thoroughly wiped on their friction surfaces with some heavy oil, with a hand mop.

The operating levers and the operator for operating the press should be as close to the press as possible, so that the various stages of the operation of the die in performing the work may be closely observed. A center mark placed on the sheets, and corresponding center marks on the dies, will greatly facilitate the centering of the hot sheet on the dies and save time. The larger sheets, after being flanged, will be found more or less out of true on their flat surfaces and will require straightening. The iron straightening floor referred to is provided for this purpose, and this work can be done with the remaining heat in the sheet after flanging.

All flanged sheets should be thoroughly and carefully annealed after they are finished and before being placed in the boiler. Flanging by power being practically one operation, will undoubtedly introduce into the sheet less local strains than would be the case with hand flanging, and such as it may produce are effectively removed by the careful annealing suggested.

Dies for Machine Flanging.

The accumulation of dies for this character of work, unless they are carefully designed, with a view of preventing unnecessary duplication, becomes a serious matter, as they occupy considerable space and represent a large investment.

Figures 12 to 17 inclusive illustrate a convenient way of making some of the more intricate forms of these dies in sections, permitting the introduction of liners for change of dimensions, and new pieces of irregular shape where the outside shape is changed. These are also intended to illustrate a convenient record of the dies themselves, which the writer has had in operation for several years, and found perfectly satisfactory. Each one of the diagrams is intended to show only the castings used for that particular die and class of engine. In each case where this same die would be used for another class of engine another diagram is provided. These diagrams should bear all of the information which would be vital as a matter of record of the dies, and they should be accompanied by tables of the parts, numbered, and by the use of a gauge on the flanging press blank spaces, giving pressure required to raise the dies and table per square inch, and also to do the work of flanging, may be filled in. This will become a source of data in connection with the question of power required for this kind of work and a means of comparison in questions of flanging new work not as yet tried.

These dies may be designed so as to reduce the amount of machine work in their construction to a minimum, and this is specially true where they are made sectional, it being only necessary to have them cast of the proper shape and as smooth as possible. A file finish on the friction surfaces in most cases will be found sufficient, and while it undoubtedly absorbs somewhat more of the power of the machine, the saving is so great compared with this advantage that the method becomes an economical one.

The speed with which the dies are brought together has a very important bearing upon the success of the work, and in some cases it will be found that better work can be done, as regards the tucking up of corners, where a large amount of metal is to be upset, by changing the speed of the table, or opening the operating valve only partially, as may be determined by experience. We have known cases where dies thought to be defective have proven perfectly satisfactory by merely changing the speed of travel of the table.

The following formula will be found of assistance in determining the greatest depth of flange permissible for good, average work:



$$F=D+1-3 R=14 \text{ times } T \text{ or thickness of sheet.}$$

It is true that in some cases greater depths than this can be flanged, but its continuance cannot be relied upon. Generally speaking, unless the radius is excessively large, the depth of flange which may be successfully made without excessive buckling will not exceed 14 times the thickness of the sheet. Where it is desired to secure a greater depth of flange than this, it may be secured by drawing instead of flanging, the ordinary form of dies consisting of an upper ring, which is practically a female die, a lower or clamping ring and a male die, which in its shape conforms to the inside shape of the sheet to be produced. In the case of thin material, unless extra care is taken to work the sheet very quickly, considerable difficulty will be experienced in removing the sheet from the male die after it has been drawn in this way. This is especially true where no taper has been allowed in the male die, and which in some work is objectionable. A convenient way of getting over this difficulty is to leave sufficient stock on the blank so that, when it is formed up to the proper depth of

flange, there will still be a small amount, either remaining in, or only partly removed from the female die, making the holding-up ring of such a size that this excess material will present a larger diameter than the outside diameter of the finished piece, and will in this way act as a stripper on the male die. The excess material is so very slight that its loss as scrap is a trifle compared with the lost time and annoyance of reheating the sheet after it has shrunk on the die.

Interchangeability and Templets.

With comparatively few exceptions, templets for location of punched holes may be omitted where satisfactory spacing punches are provided. A complete system, however, of templets should be prepared, with the view of securing absolute interchangeability in a large number of duplicate parts for the same type of boiler. These templets may either be made from a special material, ordered for the purpose, or in some cases, where this expense is not warranted, they may be made from one set of sheets, which will be finally used for the last boiler on that order. The checking of these templets should be done by at least two men thoroughly conversant with their use, to prevent any possibility of error. With properly prepared templets and careful supervision of detail, all of the sheets in the boiler, when delivered to the fitting up department, should be interchangeable. A practical demonstration of this, covering a period of several years, has more than proved to the writer that, following modern methods, there is no necessity whatever of putting up and marking off sheets, which is still a frequent practice in some boiler shops. All of this excessive rehandling can be avoided by the templets referred to. In the case of holes in connecting or throat sheets for barrel and fire box connections, these throat sheets may be placed on a surface plate, properly leveled and lined up, and the holes laid off, both for the barrel connection and the fire box connection on parallel planes. As the holes in the fire box and the barrel have been previously accurately punched to templet, there is no reason why this hip or connecting sheet, having been flanged in dies which produce them all in duplicate, should not be interchangeable on all boilers of the same type, and when once placed in position remain there.

The use of heavy sledges in connection with the fitting up should by all means be prohibited, as the high grade of material used in present boiler construction does not admit of punishment of this kind, and in thick sheets the vibrations set up by repeated blows of a heavy sledge are very apt to crack portions of them, especially through the holes.

Sheets that have not been properly formed should be reformed after being heated, and no attempt should be made to do either this work or scarfing cold. Not only does the heat in the case of fire box sheets have considerable to do with the efficiency of the scarfing, but the location of the anvil at which the scarfing is done. We have known of one or two cases where fire box material of excellent quality has been condemned as being too brittle when the only reason why it failed or cracked in the scarfing was because the anvil on which the scarfing was being done was located too near a door; it being in the winter-time, the cold draught across that portion of the sheet allowed it to cool too quickly and gave opportunity for cracking.

Tack bolts should be placed in at least every other hole on the more important sheets when they are fitted up and tightly drawn. All barrel sheets and side sheets should fit sufficiently close, without straining seriously, to permit of a flat gauge, 0.015 of an inch in thickness to go no further than the center line of the first row of holes.

On the mud ring, in addition to the inside and outside the front and back surfaces of the bottom should be finished, and the templet used for laying off the holes in the side sheets should have points of contact with these bottom surfaces. As the side sheets themselves are laid off with reference to a center line, it will be obvious that when the mud ring is in place these finished places will answer as datum points to work from

in lining up the barrel. The same thing is true with reference to the front end extension and its rings, and the result will be that when the boiler is connected up the center lines will coincide, and the center line of the boiler will bear a definite relation to the surfaces of the mud ring and will be similar on all boilers of the same design. The absolute accuracy of this method of lining up permits of the chipping of the cylinder saddles to a templet without incurring the lost time usual in placing the boiler on the frames, marking off and blocking up. This will be explained further in connection with the use of templates in the erecting shop.

rivets machine driven is as reliable as first class iron rivets. A rapid distortion at one operation of the steel formed head is more than liable to reduce the tensile strength of the head; in other words, were the steel rivet driven by hand the head would be stronger than when driven by machine, and the contrary would be the case with the iron rivet. This is well recognized on conditions where snap riveting is required and a leakage of the rivet in service requires calking. Under these conditions the steel rivet will stand more calking than the iron rivet, for the reason that the working, due to hard driving, has a refining effect on the steel, and seems to improve its

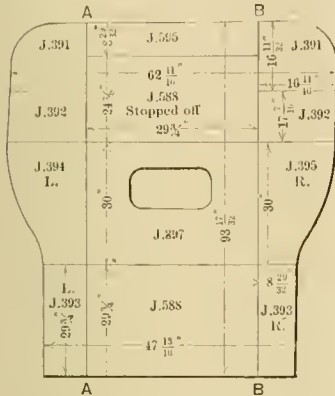

Fig. 12.—Male Die, Back Head.

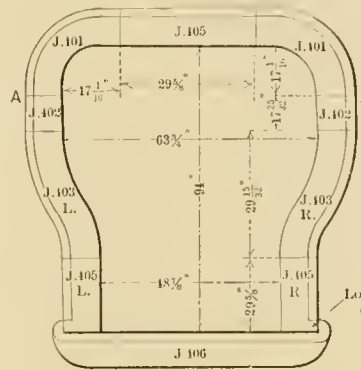

Fig. 13.—Female Die, Back Head.

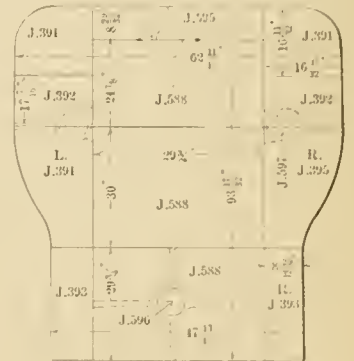

Fig. 14.—Holder Plate.

Gauge and surface cock holes and various other holes for connections on the back head are provided in the templet and punched in the sheet in the boiler shop; also certain holes for cylinder saddles in the front end.

Riveting.

Where possible the contact surfaces of riveted joints before riveting should be thoroughly acid-washed to remove any excess scale. After the sheets are thoroughly bolted up and rigidly held in place, the intermediate holes may be reamed to the proper size and the bolts in the other holes inserted suc-

toughness; whereas the distortion and twisting of the grain of the iron rivet in driving seems to weaken instead of strengthen it.

The heating of the rivets should be done in such a way as to give the minimum amount of scale, and every precaution should be taken to free them from scale before being driven. The interposition of this scale between the rivet and the surface of the hole and the head of the rivet and the surface of the sheet is frequently the cause of leakage and loose rivets.

All riveting, as well as the character of fitting up, fitting up

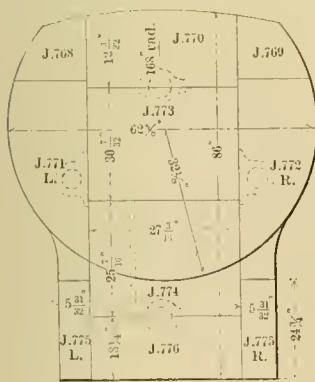

Fig. 15.—Back Tube Sheet Holder Plate.

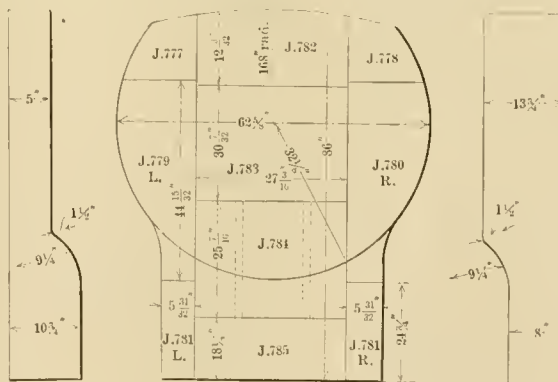

Fig. 16.—Back Tube Sheet, Male.

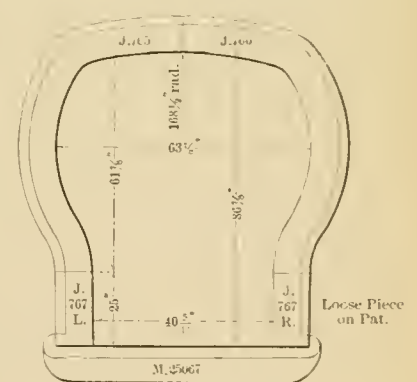

Fig. 17.—Female Die.

cessively in the reamed holes and drawn up tight; the balance of the holes may then be reamed and the work riveted before the bolts are removed. All of the holes should have the small fin due to reaming slightly removed; in fact, be very slightly countersunk; this should not exceed 1-32 inch.

Great care should be used in not only the heating, but the driving of rivets, and a form of head used which will permit of prompt upsetting of the shank of the rivet in the full size of the hole, also providing the minimum amount of extension on the plate consistent with the maximum amount of vertical strength through the head. In a properly designed head of this kind the set will be of such shape that the end of the rivet on which the head is formed will promptly center itself, and there will be little danger of heads driving out of center.

We do not consider, as a general thing, that the use of steel

braces, which is included in the fitting up, should be subject to frequent and very careful inspection, and we wish to emphasize that it is only by the most rigid inspection of the smallest details in the construction of the present type of high pressure boilers that the best work can be secured.

Stay Bolts.

While it is true that design, quality of material and general treatment in service are many times largely responsible for the excessive breaking of stay bolts, we believe that, in a great many cases, the blame is placed on these causes when in reality the methods and the non-observance of the little things of importance in putting in stay bolts deserves full credit as the principal cause.

The variation of lead in taps and between outside and inside side sheets is responsible for a great deal of discussion on

these lines. When it is borne in mind that the greatest variation, without counting an additional thread, cannot exceed 1-24 of an inch, it will be obvious that not only must the side sheets be absolutely right, but remain in that position against the action of the tap, which, while tapping the outside side sheet, is frequently starting the first threads on the inside side sheet, with all of the severe resistance of a feed of 1-12 of an inch, and we have seen cases in which, following the tapping of each hole, the stay bolts themselves were inserted and a straight-edge, placed on the inside side sheet before and after the row of bolts has been inserted, indicated a variation of at least $\frac{1}{4}$ -inch out of a straight line. This can be and should be prevented by careful supervision of this part of the work and the insertion of either cross spacers to prevent this thrust, or, at satisfactory intervals, stay bolts, which would act as stays, keeping the sheet in a perfectly straight line, and consequently normal.

The riveting up of stay bolts after insertion is too frequently considered such an ordinary form of labor that not enough attention is paid to it, and we have noted cases in which the bolt had been sufficiently hammered, not only to upset thoroughly the threads into the threaded portion of the sheet, but to increase the diameter of the bolt beyond the sheet. We cannot conceive that this bolt would have the maximum life at the juncture of the sheet and the bolt, or the point where this upsetting takes place.

The common method of holding up on these bolts while being riveted does not permit of a perfectly uniform resistance against the end of the bolt on the inside of the fire box. The space being somewhat contracted, there are only a few points in which a man can assume a position of greatest purchase on the lever bar. The result is that at these points the bolts are riveted up with one resistance, and at other points with a different resistance. The disadvantages of this will also be obvious. A very simple and efficient form of pneumatic holding up arrangement has been introduced for this purpose, and to a very large extent will overcome the factor of unequal resistance while hammering up. It is our opinion, however, that these bolts get entirely too much hammering up, and a great deal more than what is required if they were properly fitted in the first place and a correct standard of sizes of taps maintained. The taps used in this character of work should be subject to check when in regular service at least once a week, and the results of the machine used for threading stay bolts inspected at least once in every ten hours.

Flue Work.

Another factor entering very largely into the expense of maintenance and reduction of cost per engine mile is the character of flue work. This department should be in charge of a competent man, who gives it his sole attention, and one sufficiently ambitious to thoroughly follow up all of the detail. It is not necessary to safe-end flues in new work. The material in the body of the flue, if sufficient for proper length of service, should be good enough to take the place of a safe end.

All of the tools used in this department should be of such a kind as will give the least possible variation in sizes, due to wear, in the preparation of the flues. For the swaging the use of hollow dies has been found decidedly advantageous over the ordinary and older methods of doing this work. These dies are very efficiently used in a machine operated by compressed air, and not only maintain their size, but give an absolutely uniform result in the work.

Particular attention should be given to the maintenance of a standard in the shop of the Prosser expanders used, and a frequent inspection of these will go a long way to prevent the introduction of defective work due to the usage of tools of this kind worn and unfit for service, but apparently in perfect condition, until standard gauges are tried on them.

The general use of pneumatic appliances for reaming, tap-

ping, beading, calking and doing a great variety of small work in connection with boiler construction, will prove very advantageous in the interest of economy.

(To be Continued.)

NEW RULES FOR CONSTRUCTING MARINE BOILERS

According to a circular recently issued by the Treasury Department, Steamboat Inspection Service, all boilers built for marine purposes after July 1, 1898, shall be required to have all the rivet holes [in the shell] "fairly drilled" instead of punched, and the longitudinal laps of their cylindrical parts double riveted, to be entitled to 20 per cent. additional pressure. (Also that steel plates of one-half an inch thickness and over for all boilers shall have all the rivet holes in the shell "fairly drilled" instead of punched.)

No braces or stays hereafter employed in the construction of boilers shall be allowed a greater strain than 6,000 pounds per square inch of section, and no solid or hollow screw stay bolt shall be allowed to be used in the construction of marine boilers in which salt water is used to generate steam unless said screw stay bolt is protected by a socket. But such screw stay bolts without socket may be used in staying the fireboxes and furnaces of such boilers and elsewhere when such screw stay bolts are drilled at each end with a hole not less than one-eighth inch diameter to a depth of at least one-half inch beyond inside surface of sheet, when fresh water is used for generating steam in said boilers (to take effect on and after July 1, on all boilers contracted for or construction commenced on or after that date). Water used from a surface condenser shall be deemed fresh water. The flat surface at back connection or back end of boilers may be stayed by the use of a tube, the ends of which being expanded in holes in each sheet beaded and further secured by a bolt passing through the tube and secured by a nut. An allowance of steam shall be given from the outside diameter of pipe.

For instance, if the pipe used be $1\frac{1}{2}$ inches diameter, outside, with a $1\frac{1}{2}$ -inch bolt through it, the allowance will be the same as if a $1\frac{1}{2}$ -inch bolt were used in lieu of the pipe and bolt. And no brace or stay bolt used in a marine boiler will be allowed to be placed more than $10\frac{1}{2}$ inches from center to center to brace flat surfaces or fireboxes, furnaces and back connections; nor on these than a greater distance than will be determined by the Board's formulas. Flat surface on heads of boilers may be stiffened with doubling plate, tees, or angles.

Electricity is largely used for working the cranes at the Crewe shops of the London and North-Western Railway, the equipment having been briefly described in "The Practical Engineer." The motors have field magnets of the Manchester type, with Paccinotti armatures. In starting a motor, a variable resistance is switched in to diminish the starting current, being cut out when the motor is fairly running. All the motors used are designed to run at 1,500 revolutions per minute, the speed being afterwards reduced by worm gearing. In the case of the 30-ton cranes used in the erecting shops for lifting locomotives, the load is lifted at a speed of 2 ft. 6 in. per minute at an expenditure of 70 amperes at 120 volts. The long traveling is performed at a speed of 100 ft. per minute, with an expenditure of 60 amperes at 120 volts, and the cross traverse at a speed of 50 ft. per minute, with an expenditure of 30 amperes at 120 volts. In the case of light weights the speed of lifting is 10 ft. per minute. In the case of the 15-ton crane, which has been provided in connection with a boiler-riveting plant, the crane is 50 ft. above the floor level, and all its movements are controlled by switches on the ground, a magnetic brake being provided on the armature shaft to arrest the motion as soon as a rivet hole has been brought into place for the closing of the rivet. The cost of repairs has, Mr. Webb states, so far been very small; no renewal of commutators has been necessary, but they are lightly skimmed up in the lathe about once in twelve months. The carbon switches and brushes are renewed once in six months.

NEW FREIGHT TRUCKS.—LOUISVILLE & NASHVILLE RAILROAD.

The drawing of new freight trucks in use on the Louisville & Nashville Railroad, from which the accompanying engravings were made, was received from Mr. Pulaski Leeds, Superintendent of Machinery.

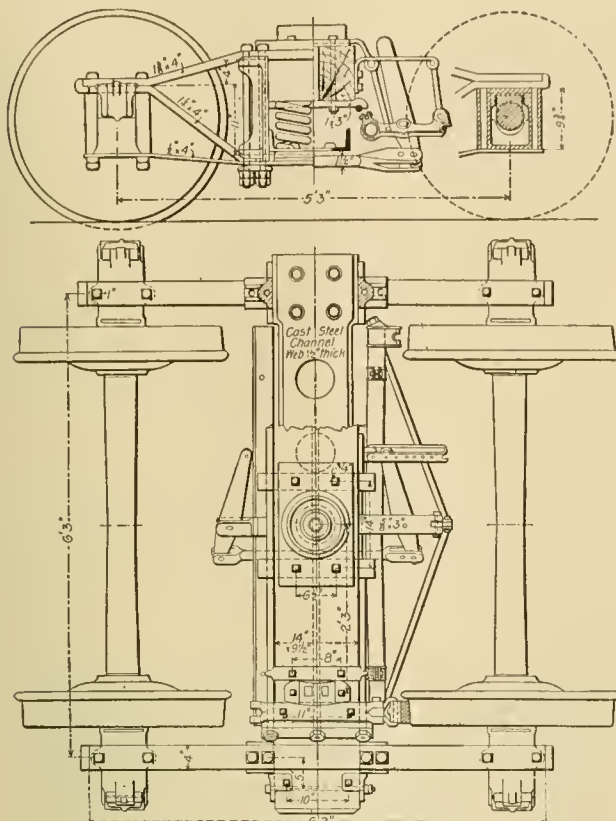

Truck Fitted with Wooden Bolster.

The trucks are of the diamond, arch bar type, designed with the special object of bringing the bearing low enough to admit of using an efficient depth in the body bolster.

Three forms of truck bolsters are shown; one is the Bettendorf, another is of cast steel and the third is of wood, with truss rods. The different arrangements of springs are also il-

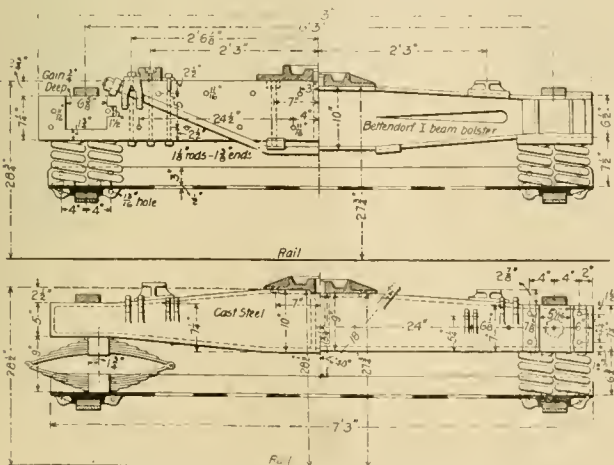

Showing Steel Bolsters and Spring Plank.

lustrated, and it will be noted that the spring plank is in the form of a channel of cast steel, the web of which is 1/2-inch thick, the ends being formed to receive the arch bars and columns. This form was chosen in order to obtain room for the 5 3/4 by 7-inch springs and at the same time to get the brake beams as nearly opposite the centers of the wheels as possible

with a reasonable wheel base. The brakes are hung from the top of the bolster in order to get the benefit of the springs in the brake connections. The form of this spring plank necessitated using cast steel and Mr. Leeds is now considering the advisability of extending the castings with wings under the columns in order to have the lips over the lower arch bar, now formed by the columns, as integral parts of the spring plank, furnishing a rigid guide for the arch bar 23 1/2 inches in length, which ought to serve the important purpose of keeping the truck square. This spring plank was designed so that it will meet the requirements of new trucks and it will also go in all the old trucks used on this system, all of which have a distance of 14 inches between the columns. The form of the spring plank gives it sufficient strength without undue weight, and to make it lighter large holes are bored through the web at intervals, as shown. It weighs 230 lbs., and the cast bolster weighs 650 lbs.

The wheel bases of these trucks are 5 ft. 3 in. and the height from top of rail to lower face of center plate is 28 3/4 inches for the wooden bolster, 28 1/2 inches for the cast steel bolster and 27 3/4 inches for the Bettendorf bolster. The National Hollow and the Sterlingworth brake beams are used.

The use of cast steel bolsters on this road is experimental as yet, they are to be used under 100 furniture cars now building. Mr. Leeds favors the cast steel bolster of the box form as being well adapted to resist all of the strains brought upon it, both vertical and transverse. The bolster and spring planks which have been made from this drawing and put into service were made by the Shickle, Harrison & Howard Iron Co. of St. Louis.

LOCOMOTIVE DESIGN.

The Working Stress of Materials.

By Francis J. Cole.

Crank Pins.

(Continued from page 125.)

A crank pin may be designed correctly for the stress at the wheel fit and yet be so reduced in size for the rod bearings as to fall below the curve of a beam of equal strength. When this occurs the greatest stress will be at this point instead of at the face of the wheel. This is shown in Fig. 7, the dotted lines indicate the shape of a solid circular beam of uniform strength, fixed at one end and loaded at the other with a single load W. The maximum bending moment at A is W l. For different points along its length, this decreases directly as the distance from the load W. The form of a beam of this kind is a cubic parabola and the formula for its various diameters is:

$$y^3 = \frac{32 w}{\pi f} x$$

In which:

y—the diameter for any distance x.

f—the stress per square inch.

x—the distance from load for diameter y.

w—the load in pounds.

It may be also constructed from the diagram Fig. 6 by multiplying the load by the distance in inches and plotting the diameter found in the diagram for the corresponding moment, at intervals of one inch and drawing the curve to pass through the points so found. An approximate form given by Unwin is a truncated cone, whose small diameter is two-thirds of the diameter at the point of fixture.

The sizes of the crank pins for bearing surfaces must also be considered. This is taken as the projected area, or what is the same thing, the diameter multiplied by the length of the bearing surface. While certain pressures are suggested as representing what would be the most suitable for the purpose, providing ample surface with a moderate pressure per square inch, without going to the extreme in the matter of large surfaces, by the use of too large or clumsy sizes, it is often con-

venient to know how wide a range may be permitted and still keep within the bounds of pressures now in use on locomotives in successful operation. The pressure per square inch of bearing surface ranges from 3,500 to 5,800 pounds for the front or crosshead end of the main rod; about 4,200 pounds will be found most suitable for this purpose. The back end of main rod ranges from 1,350 to 2,670 pounds; about 1,700 pounds will be found most suitable for this purpose. For parallel connecting rods the range is from 850 to 2,100 pounds; about 1,000 to 1,200 pounds will be found most suitable.

Several instances will now be given of engines which came under the writer's personal observation for a number of years.

Ten wheel engines, giving six years' service, no breakages occurred with steel pins of not less than 70,000 pounds tensile strength. The following were the dimensions: Diameter of main pin in wheel, 6¼ inches; to center of main rod, 8¼ inches; to the center of parallel rod, 3 inches; diameter of cylinder, 20 inches; steam pressure, 165 pounds.

Primary bending moment = $20^2 \pi \times 165 \times 8.25 = 427,432$.

Support of parallel rod = $\frac{20^2 \pi \times 165 \times 3 \times 2}{3} = 103,620$.

Actual bending moment = $427,432 - 103,620 = 323,812$.

Section modulus for 6¼ inches diameter = $.0982d^3 = 23.97$.

Maximum fibre stress per square inch = $\frac{323,800}{23.97} = 13,500$ lbs.

Consolidation engines—Hammered iron main pins, several broke, tensile strength probably about 47,000 to 48,000 pounds per square inch. Diameter of main pin in wheel, 5

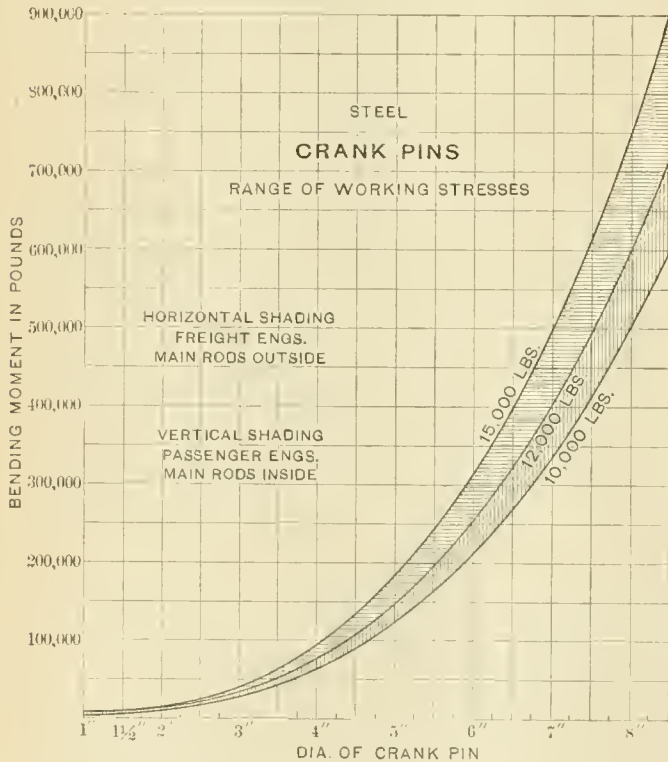

Fig. 6.

inches; to center of main rod, 7¼ inches; to center of parallel rod, 2½ inches; diameter of cylinder, 20 inches; steam pressure, 140 pounds— $20^2 \pi \times 140 = 43,900$

Primary bending moment = $43,900 \times 7.125 = 312,787$.

Support of parallel rod = $\frac{43,900 \times 2.5 \times 3}{4} = 82,310$.

Actual bending moment = $312,787 - 82,310 = 230,477$.

Section modulus for 5 inches diameter = 12.27 .

Maximum fibre stress per square inch = $\frac{230,400}{12.27} = 18,800$ lbs.

Consolidation engines—Hammered iron main pins often break with a maximum fibre stress per square inch of 19,730 pounds.

Four wheel switching engines—Main pins break regularly after running two or three years. Steel and iron used for these pins with a maximum fibre stress of 29,000 pounds per square inch. It is remarkable that they lasted so long, however these engines made a very low mileage per month.

Eight wheeled American type—Back pins occasionally break. Steel pins, tensile strength about 70,000 pounds; maximum fibre stress, 14,510 pounds per square inch.

Eight wheel American type—No record of breakage in four

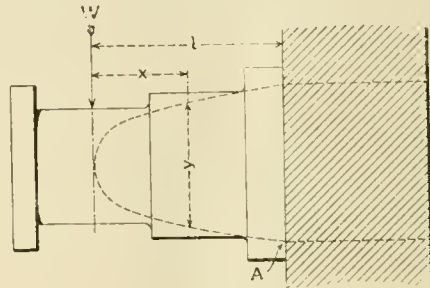

Fig. 7.

years. Steel pins, tensile strength about 75,000 pounds per square inch. Maximum fiber stress on back pin, 12,170 pounds.

Eight wheel American type—No record of breakage in six years with steel pins, tensile strength about 75,000 pounds; maximum fibre stress on back pin, 13,442 pounds per square inch.

Hollow crank pins at the present time are being used to a limited extent on a number of locomotives. Their points of superiority are lightness, increased strength for a given weight, and the partial removal of initial forging strains. Two ways of manufacture are available—to forge them hollow or to drill out the hole after forging. The former method has only a very limited application for crank pins of unusually large diameters when used with rods having straps, and when the collar of the pin is integral, as in Fig. 8, this permits of a hole of the same diameter being run entirely through the pin from end to end. Where solid end rods with bushings are used a loose collar is necessary in order to slip the rod over the crank pins. These loose collars must be secured either by reducing the end of the crank pin to a size suitable for screw threads and using one or two nuts, as shown in Fig. 9, or by the use of a bolt screwed into the end, either of the methods requiring a solid end to the crank pin.

The section modulus R of a hollow circle (Fig. 10) = $0.0982 \left(D^3 - \frac{d^3}{D} \right)$. For a section where D=6 inches and d=3 inches

$R = 0.0982 \times \left(6^3 - \frac{3^3}{6} \right) = 19.88$. For a solid circular section six inches in diameter R=21.21. The decrease in strength of

the hollow section is $\frac{21.21 - 19.88}{21.21} = 6.2$ per cent. The decrease

in weight is $\frac{94.25 - 70.69}{94.25} = 25$ per cent. For the above ratios

and diameters the decrease in weight is about four times as

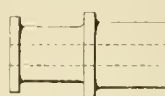

Fig. 8.



Fig. 9.



Fig. 10.

much as the decrease in strength. Where the material is oil tempered the hollow section is doubtless the best form, as the cooling strains are much less severe, permitting the oil to be applied simultaneously internally and externally. Whether

the increase of strength or decrease of weight is worth the extra expense of manufacturing these hollow sections is a question which at present there is not sufficient information at hand to answer definitely. Two facts seem clear, however: First, That with certain methods of treating steel, their use seems advisable. Second, Where reduction of weight is absolutely necessary (the decrease in weight is comparatively small, however) a two or two and a half-inch diameter hole in all but the largest engine will be found as large as it is advisable to use.

An account of the beneficial effect of oil tempering steel was published some time ago from some tests made on the Lehigh Valley Railroad of a broken crank pin before and after being oil tempered. The following is an abstract of the results:

Dimensions.		Test.				Remarks.
Size.	Length	Tensile	Elastic ten-	Ex-	P. C.	
in.	in.	Strength	Limit	ension.	Contraction.	
0.499	2	88,970	39,880	17.25	43.50	Specimen cut from pin as received.
0.499	2	88,460	39,880	17.25	43.50	Specimen cut from pin as received.
0.500	2	94,220	39,720	16.85	21.43	Specimen cut from pin as received.
0.498	2	97,540	54,430	23.10	50.31	From piece of pin after boring hole 2 in. in diameter and oil-tempering and annealing.

Analysis: Carbon, .53; manganese, .59; phosphorus, .47; sulphur, .069; silicon, .170.

"The result of oil-tempering and annealing the same steel cut from the broken pin was an increase in tensile strength of 7.7 per cent., in elastic limit of 36.6 per cent., in extension of 34.9 per cent. and in contraction of area of 39.1 per cent."

Ultimate strength.....91,000 lbs. per square inch
 Elongation25.06 per cent.
 Elastic limit.....57,000 lbs. per square inch
 Contraction56.46 per cent.

It is a fact, however, that the use of a high grade of open hearth carbon steel having a tensile strength of from 80,000 to 90,000 pounds, with an elongation of 22 per cent. in two inches and phosphorus not exceeding 0.05 will give very satisfactory results, provided the proportions are such as to keep the fiber stress within reasonable limits. Large fillets should be provided at the wheel fit, collars, etc., and sharp corners should be avoided whenever steel is used.

Corrections.

Typographical errors occurred on page 124 of our April issue as follows: In the seventh line of the second column for 0.0982 d read 0.0982 d³, and in the fifteenth line of the same column

$$\text{for } d = \sqrt[3]{\frac{W l}{0.0982 d^3}}, \text{ read}$$

$$d = \sqrt[3]{\frac{W l}{0.0982 S}}$$

(The next subject treated by Mr. Cole will be "Driving Axles."—Editor.)

BOILER STEEL INGOTS.

By aid of the microscope the Baldwin Locomotive Works some time ago traced the causes for the failure of certain plates of boiler steel which fully met their requirements, both physically and chemically, to conditions of manufacture which undoubtedly have an important influence upon the wearing



Sections of Ingots, Reduced in Size.

From recent reports and experiments on the characteristics of steel alloyed with from 3 to 5 per cent. of nickel, commonly known as "nickel steel," this material seems well adapted for crank pins, and especially so for renewals in engines which have been improperly designed, where the length of the pin or its small diameter produces such a high stress that the use of the best and strongest material, regardless of its cost, is advisable, rather than incur the repetition of expensive breakdowns. Nickel steel possesses the valuable property of a ragged, irregular fracture, partaking more of wrought iron than the clear, sharp breakage peculiar to steel. A crack once started does not seem to extend through the entire piece so rapidly as in ordinary steel. From specimens tested at the Watertown Arsenal the elastic limit was over 100,000 pounds, and the ultimate strength 115,000 to 118,000 pounds per square inch. Tests of nickel steel used in the construction of the new locomotive at the Purdue University give:

qualities of the plates. A microscopic examination was made of some plates which had prematurely failed in service, which, however, had previously met all of the specifications as to strength, elongation, character of fracture and chemical constituents. It was found that the plates contained minute laminations, which would satisfactorily account for their action in service, and as they appeared to be due to the presence of blow-holes and segregation in the ingots from which the plates were rolled, an experiment was made to ascertain the probable presence or absence of such laminations in the products of the various steel manufacturers.

An ingot was ordered from each of six boiler steel makers, with, as we understand it, instructions to furnish an ingot from the regular stock of the works, one that would otherwise be made into plates, this being done with a view of obtaining a fair sample. These sample ingots were sectioned and the photographs show the appearance of the surfaces of four of them. The section "A" was taken from the lower third of a long ingot, while the others were taken at the centres of ordinary small ingots.

Segregation is apparent in all except section A but it is most

marked in section B. All of the sections show blowholes, but section A the least, and only about the edges, while the others are badly honeycombed all over. The manufacturer's names would be exceedingly interesting in this connection, but we are not at liberty to print them.

This exhibit is suggestive of several important things. The manufacture of boiler plate is as important as the physical properties which are usually watched so carefully, because there appears to be danger of mechanical defects in the product which the usual tests do not expose. There is apparently good reason to believe that all such material should be rolled from large ingots, from which very large crop ends should be cut in order to avoid the segregation and honeycombing in the portions of the ingots that are used for boiler plate. In view of the higher boiler pressures and the evident tendency to increase still further (we know of one road contemplating using 225 pounds per sq. in. and throttling down to 175 pounds before the steam enters the cylinders) there cannot be too many precautions taken to avoid causes for failure of the plates. If these photographs show current practice among steel makers, and we believe they do, radical improvements in the making and rolling of ingots cannot be introduced too quickly and the manufacturers of these spongy ingots should lose no time in making and rolling ingots like the one in the section at A.

HOLLOW, NICKEL STEEL DRIVING AXLES AND CRANK PINS—PURDUE EXPERIMENTAL LOCOMOTIVE.

In the illustrated description of the new Purdue laboratory locomotive in our January issue of the current volume the hollow nickel steel driving axles and crank pins furnished by the Bethlehem Iron Company were mentioned. It was noted that the great mortality of these parts of locomotives has led engineers to seek for some metal of high elastic limit and elongation that would resist the severe alternating stresses to which they are subjected. The accompanying drawings show the designs adopted for these parts, the material used having the

not only restores the ultimate strength and elastic limit, but increases the elongation and contraction very considerably.

When it is remembered that a severe compressive stress, sometimes closely approaching the elastic limit, is applied to the metal of pins and axles by forcing them into wheels, it is not surprising that their life is short at the point where this stress is applied. For such service as is required of crank and crosshead pins, axles, piston and connecting rods, and all forgings subjected to stresses alternating from tension to compression, a metal possessing the very highest elastic limit possible should be supplied. Such a metal can now be obtained by an alloy of the steel and a low percentage of nickel, and by oil tempering. Test bars of this metal, 1/2 inch in diameter and 2 inches long between measuring points, show the following physical properties:

Tensile strength.....	80,200 to 90,000 lbs. per sq. in.
Elastic limit.....	50,000 to 60,000 lbs. per sq. in.
Elongation.....	25 to 22 per cent.
Contraction.....	60 to 50 per cent.

Many railroads are now taking up the use of this metal generally, having tested it experimentally and found to their satisfaction that by a small initial increased expense they can save largely by having fewer breaks with their attendant delays and damage.

A high price is paid for coal in the California Mountains. The Consolidated Coal Company, whose mines are on the Baltimore and Ohio Railroad near Cumberland, Md., ship considerable coal to San Francisco for smelting purposes, and the cost of the coal at the mines and the price at which it is sold to consumers in certain parts of California has developed an interesting situation with reference to transportation charges. The company gets 85 cents a ton for the coal at the mines and then it is sent over the B. and O. to Locust Point, where it is loaded on vessels and goes around the Horn to San Francisco. From there it is shipped by rail to the interior points, and then

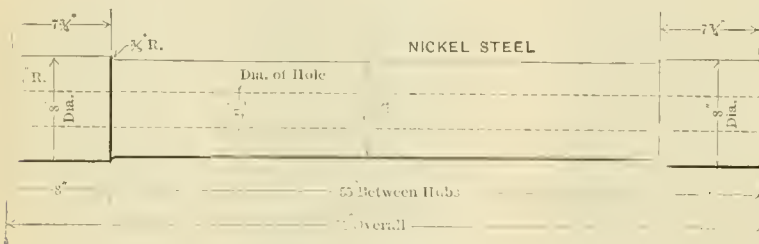

Hollow Driving Axle.

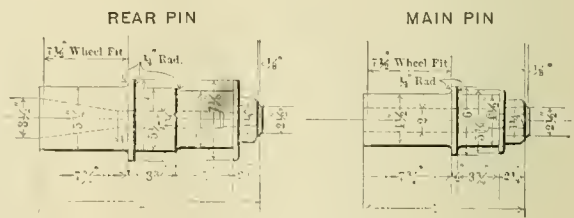

Hollow Crank Pins.

following characteristics: Ultimate tensile strength, 91,000 pounds per square inch; elastic limit, 57,000 pounds; elongation, 25.05 per cent.; contraction, 56.45 per cent., the test specimens being two inches long between the measuring points. These parts are oil tempered, the axles were forged upon mandrils and the crank pins were bored. Attention is called to the fillets allowed where the axles and pins change diameters, also to the fact that the wheel fits are the largest portion of the forgings, except at the collars of the pins. This is a very important improvement, the object of which is to assure against fracture in the concealed wheel fit. Fractures will occur, if at all, at the weakest point which in these cases will not be in the wheel fits, but outside where cracks will be likely to be discovered when the rods are removed.

Mr. H. F. J. Porter, of the Bethlehem Iron Company, in an admirable paper read before the Western Railway Club in February, stated the advantages of hollow forgings and nickel steel for axles and crank pins, as follows:

The surface metal of solid forgings is apt to shrink on to the metal of the interior to such an extent as to crack it open. In order, therefore, to oil temper a forging with safety it should be hollow to allow the heat to be extracted equally from the interior and surface metal.

Annealing lowers the ultimate strength and elastic limit of steel, but increases its toughness or ductility, as shown by the elongation and contraction in test specimens. Oil tempering

placed in sacks and carried on mules to the small mining settlements scattered through the mountain. This coal is retailed in these settlements, some being hundreds of miles from the railroad, at \$100 a ton or 5 cents a pound.

The cost of locomotive power on the 16 principal English railways, as stated in "Engineering," in the second half of last year, was as follows: Great Central, £194,626, giving an average of 6.31d. per train-mile run; Great Eastern, £377,164, giving an average of 8.06d. per train-mile run; Great Northern, £424,851, giving an average of 8.59d. per train-mile run; Great Western, £781,798, giving an average of 8.47d. per train-mile run; Lancashire and Yorkshire, £347,151, giving an average of 8.93d. per train-mile run; London, Brighton & South Coast, £213,019, giving an average of 9.78d. per train-mile run; London, Chatham & Dover, £102,154, giving an average of 9.97d. per train-mile run; London, Tilbury & Southend, £25,255, giving an average of 9.84d. per train-mile run; London & North-Western, £857,833, giving an average of 8.57d. per train-mile run; London and South-Western, £295,836, giving an average of 8.34d. per train-mile run; Metropolitan, £49,955, giving an average of 7.73d. per train-mile run; Metropolitan District, £24,016, giving an average of 6.70d. per train-mile run; Midland, £882,355, giving an average of 8.80d. per train-mile run; North-Eastern, £691,019, giving an average of 10.82d. per train-mile run; North Staffordshire, £53,701, giving an average of 9.38d. per train-mile run; and South-Eastern, £177,115, giving an average of 9.46d. per train-mile run. Of course, the weight of trains, the relatively high or low cost of coal or coke, and the gradients which have to be overcome, largely explain the divergencies indicated by this summary.

THE "KENTUCKY" AND "KEARSARGE."

These two battleships, built from the same plans and launched at the yard of the Newport News Shipbuilding & Dry Dock Company at Newport News, Va., March 24, were authorized by act of Congress approved March 2, 1895, the contracts being signed January 2, 1896. When completed they will have cost about \$4,000,000 each, and for their draft will carry

are twelve 6 pounders and eight more of this size are located on the berth deck, forward and aft. A number of 1-pounders and Gatlings are provided for the fighting tops.

The armor of the 13-inch turrets is 15 inches thick, except in front, where there is an additional two inches. The armor of the 8-inch turrets is 9 inches, except in front, where it is 11 inches thick. The main turrets are of the elliptical type; they are oval in plan, with the front plates inclined

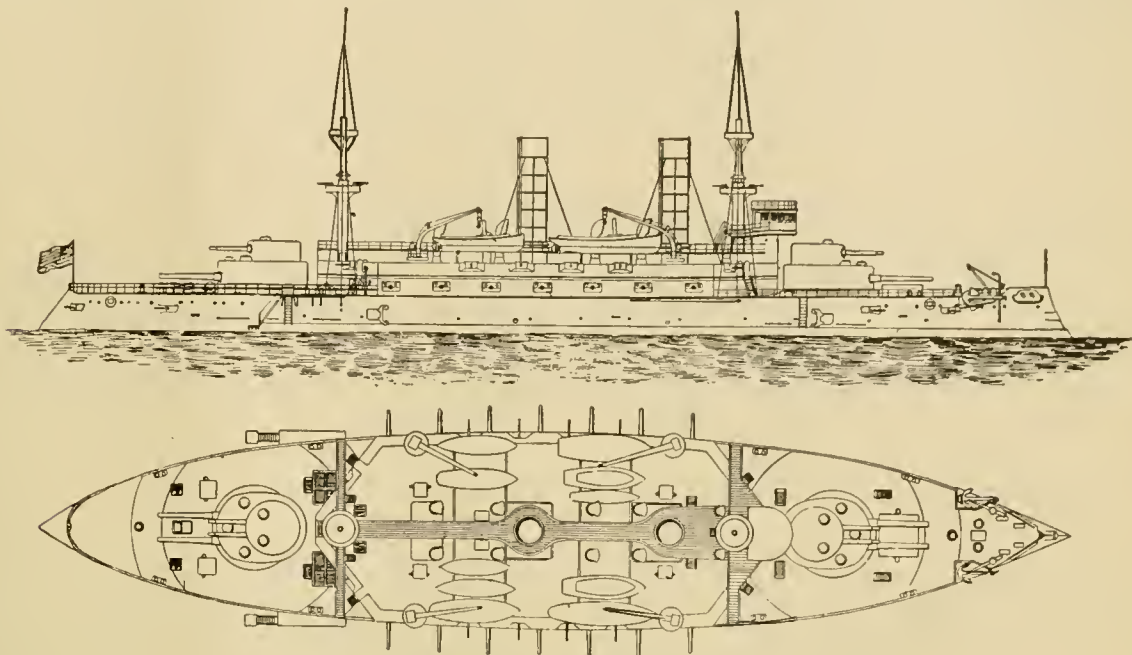

United States Battleships "Kentucky" and "Kearsarge."

the heaviest batteries afloat. There is no premium upon speed obtained in excess of the requirement, but a forfeit of \$100,000 per knot is imposed for failure to obtain the specified speed of 16 knots. The most remarkable feature of these ships is the double decked turrets, the lower ones carrying 13 inch guns and the upper ones 8 inch guns. There are five torpedo tubes, two on each side and one at the bows.

The chief features of the ships are given in the following table:

Waterline length	368 feet
Beam	72 feet 2½ inches
Draught	23 feet 6 inches
Freeboard forward	14 feet 3 inches
Freeboard aft	13 feet 3 inches
Displacement	11,525 tons
Speed	16 knots
Coal supply	410 tons
Horse power	10,000
Armor, nickel steel:	
Waterline belt	16½ inches
Side armor above belt	6 inches
Turret armor	17 and 15 inches
Barbette armor	15 inches
Conning tower	10 inches
Protective deck	2¾ inches
Armament:	
Main battery	4 13-inch guns
Submain battery	4 8-inch guns
Secondary battery	14 5-inch R. F. guns 20 6-p'nd'r R. F. guns

The small diagram of the gun plan of the "Indiana" serves to illustrate the contrast between her class and that of the new ships. In the "Indiana" eight 8-inch guns were mounted in four turrets at the corner of the central armored battery, for the purpose of training four guns on either beam or six guns directly ahead or astern, but in practice it was found that these guns interfered with the use of the 13-inch guns, and in the new ships the double deck plan was adopted. This arrangement is a bold venture, which is considered decidedly questionable, owing to the liability of disabling four guns with one successful shot.

The broadside battery of the new ships of fourteen 5-inch rapid fire guns is a noteworthy feature. Each of these guns fires through an arc of 90 degrees, and the gunners are protected by 6 inches of Harveyized armor. On the deck above

slightly and the rear plates vertical. This is an improvement on the old form of circular turret, in which there was more room than necessary at the side and too little at the rear of the guns. There are three sighting hoods, one in the centre for the man who operates the turning machinery of the turret and one on each side for the gunners.

The conning tower is just below the pilot house and abaft the forward turret. It will have armor 10 inches in thickness, with a tube 7 inches thick leading down through the armored deck, for the protection of the usual mechanical and vocal means of communication. The ships carry two military

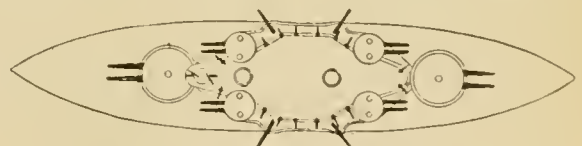

Gun Plan of the "Indiana."

masts, each of which is fitted with electric signals. The lower masts serve as air shafts.

The ships will be driven by twin screws, actuated by triple expansion engines of the direct action, vertical, inverted type. The cylinders will be 33½, 51 and 78 inches in diameter, respectively, with a common stroke of 48 inches. They are designed to develop, together with the auxiliary engines for the air and circulating pumps, a collective horse power of 10,000, when making 120 revolutions a minute. Steam will be furnished from five boilers, three double-ended and two single-ended, in four water-tight compartments. We illustrated one of the single-ended boilers in our issue of June 1897, page 198. The working pressure will be 180 pounds to the square inch. There are to be 90 auxiliary engines. The turrets and ammunition hoists will be operated by electricity.

The hulls are built of steel throughout, and are double, consisting of an inner and outer shell, spaced apart a little over three feet by the longitudinal girders and transverse frames.

At their intersections the frames and girders are riveted together and their flanges are riveted to the inner and outer shells, forming a series of water-tight cells, which will tend to restrict the damage and localize the effect of a slight collision or of striking some submerged obstacle. The double hulls round up into the sides of the ship and end in a shelf four feet below the load water line at mean draught. This shelf serves as a support for the side armor belt. This belt is $7\frac{1}{2}$ feet in mean depth, with a maximum thickness of $16\frac{1}{2}$ inches at the top, tapering to $9\frac{1}{2}$ inches at the bottom. At the water line on the mean draught it is $13\frac{3}{4}$ inches thick. When the ship has her normal supply of 410 tons of coal on board $3\frac{1}{2}$ feet of this belt of armor will show above the water, but when she

use of the present M. C. B. key, the top of which presents a convex surface for the box to rock upon, and any tendency of the box to take an inclined position by reason of any of the above mentioned causes immediately shifts the position of the load away from the center of the journal bearing key, thereby raising the unit pressure to such a degree as to materially affect the lubrication of the journal. With the constant increase in speed of trains, particularly of freight trains, and the increase of capacity of freight cars, together with the tendency toward insisting that cars shall carry their maximum tonnage, it becomes necessary to eliminate every factor that in any way contributes toward increasing the friction between the journal and its bearing. When a uniform

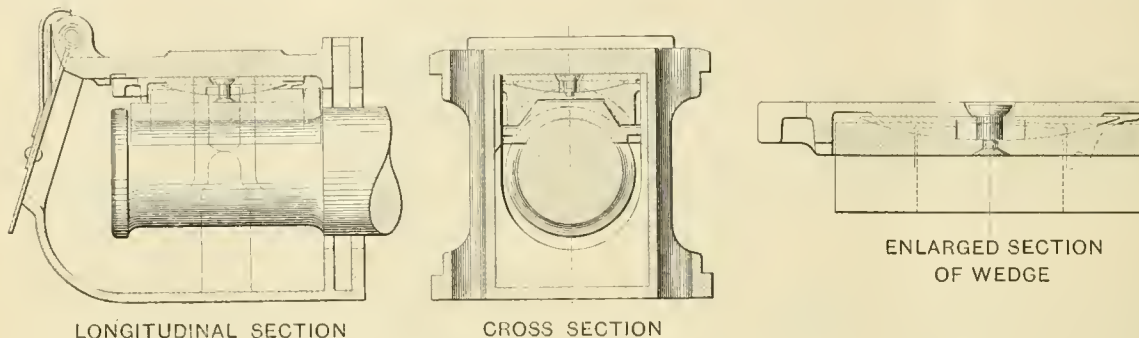

LONGITUDINAL SECTION

CROSS SECTION

ENLARGED SECTION
OF WEDGE

Adjustable Journal Bearing Keys.

is loaded to her total bunker capacity of 1,210 tons, only 2 feet of the belt armor will be above the load line.

A belt of nickel steel 5 inches thick rises above the main belt of side armor and extends up to the level of the main deck and runs fore and aft from the center of the forward barbette to the center of the after barbette. From the main side armor belt there rises a protective steel deck, which slopes at the sides down to about the water line, and rises in the center of the ship a little above the water line. On the slopes forward of the machinery and boiler spaces this deck is 3 inches thick; aft of the machinery spaces it is 5 inches thick, and on the flat it is $2\frac{3}{4}$ inches. Above the protective deck cofferdams are worked inside the casement armor, extending fore and aft along the sides of the ship about the machinery spaces. These are filled with compressed, fireproofed, American cornpith cellulose.

These ships have light draft, small area exposed as targets, heavy armor, large guns, and fair speed, which they will be able to attain with comparative ease. They will carry enough coal to steam 6,000 miles at ten knots per hour, and 4,000 miles at 13 knots. They will be fitted up as flagships, and the full complement will consist of 40 officers and 480 men.

ADJUSTABLE JOURNAL BEARING KEYS.

The object of the design of journal bearing key illustrated in the accompanying cuts was to insure having at all times, and under varying conditions, a uniformly distributed load over the entire length of the journal bearing. Very little attention has been given this feature of journal bearing keys in the past, if we may judge from the number of such that meet these requirements when trucks are new and in perfect condition, but do not provide means for successfully overcoming the poor conditions more frequently met with which develop later in the service of the truck.

Among these conditions may be cited the spreading of pedestals or bottoms of truck frames; equalizers or box springs out of position and bearing faces of equalizers not in parallel planes, all of which tend to throw the journal box out of its normal position and to apply the load to the journal bearing key at a point on one side of the center of the journal.

An eccentricity of bearing of the load often occurs with the

unit pressure can be maintained over the entire length of journal bearing, under reasonably poor conditions, one of the worst factors causing "hot boxes" will be removed.

In the key illustrated, which is the joint invention of Mr. A. M. Waitt and Mr. H. F. Ball of the Lake Shore & Michigan Southern Ry., the adjustment, to suit the irregular positions of the box, is obtained by means of a sliding plate, interposed between two other members which practically conform in outline to the M. C. B. standard key, their external dimensions being exactly the same.

The slide plate is made either of a segment of a cylinder, or of a segment of a sphere, in shape, the first mentioned furnishing adjustment lengthwise of the journal only, while the latter gives adjustments in both directions. The three members are loosely connected by a rivet, simply for ease in handling. No strain is put upon the rivet in service.

This key provides a maximum bearing surface for the box to rest upon, it adjusts itself permanently to the variations in the position of the box, allowing the brass to maintain its normal position with respect to the journal, and at the same time presents a solid mass of metal through which the load is transmitted to the journal, practically the entire length of the key. This latter feature aids materially in stiffening the brass when it becomes worn thin.

Mr. Waitt informs us that these keys have given exceedingly good service for many months on the Lake Shore road, and that in several cases of cutting and heating with the ordinary wedge the bearings were found to be worn from $\frac{1}{8}$ to 3-16 in. thinner on the inside than on the outside edge. Upon the application of the self-adjusting wedge to these boxes the uneven wear and also the trouble from heating and cutting disappeared.

SHIP CANAL—BLACK AND BALTIC SEAS.

In some of the foreign technical papers statements have been printed in regard to the beginning in the spring of the present year of work on the construction of a ship canal between the Black and Baltic Seas. The canal was supposed to be large enough for the largest ironclads, and 17 great cities were supposed to be planned along its course. We are informed by a note in the "Messenger of the Russian Ministry of Ways and Communications" that there is not the slightest foundation for such reports.

Communications.

ELECTRIC CRANES VS. TRANSFER TABLES.

Editor "American Engineer:"

I have read the article on "Cranes vs. Transfer Tables," page 126 of the April issue of the "American Engineer."

The question is covered quite fully in the article as written; and there does not seem to be anything further to be said on the subject, for the reasons as explained in the article, that in building new shops where there is ample room for placing tracks conveniently, it is preferable to use tracks as suggested and dispense with the transfer pit, necessary table, etc. The subject is aptly explained in the sentence, "Overhead cranes may be regarded as transfer tables placed inside and overhead; while they perform the only function a transfer table is capable of, they are also in constant requisition for lifting the heavy details of the engines." Nothing more can be said on the subject.

JOHN PLAYER,

Supt. Machinery, Atchison, Topeka & Santa Fe Railway.
Topeka, April 7, 1898.

Editor "American Engineer:"

When the volume of work is sufficient to warrant the installation of an electric crane, as between that and the transfer table it is the writer's opinion that there can be but one choice, viz., that of a crane.

G. W. STEVENS,

Superintendent Motive Power Lake Shore & Michigan Southern Ry.

Cleveland, April 11, 1898.

Editor "American Engineer:"

I have read the editorial on the subject of "Electric Cranes vs. Transfer Tables," and I beg to state that in my opinion the advantages of the longitudinal plan is generally overdrawn, and the summary manner in which the old-time transfer table is disposed of by ascribing to it the "limited purpose of shifting engines sideways" is another illustration of the narrow channel in which great minds sometimes run. The statement that the transfer table makes an undesirable break between shops is true, and this is the only serious objection that can be advanced. It is also true that the table and crane have certain functions which are to a limited extent identical, but the purposes of neither one can be altogether performed by the other.

As between the two plans, it is in my judgment largely a matter of taste and circumstances, each having its own peculiar advantages, with the cross track most in favor for the utilization of space and convenience. The table, of course, is a necessary adjunct to the cross track plan, and in this connection cannot profitably be dispensed with, and there are innumerable purposes aside from the moving of engines which the table will accomplish with a rapidity not possible with the crane.

JAMES M'NAUGHTON,

Superintendent Motive Power Wisconsin Central Lines.
Waukesha, April 18, 1898.

Editor "American Engineer:"

I have read with a great deal of interest the article on "Electric Cranes vs. Transfer Tables," on page 126 of your April issue. The views you give on this subject are full, and coincide with my views, which are borne out by practical experience.

I must say, that previous to putting up electric cranes in our shop, at Mt. Clare*, I was a little skeptical about longitudinal erecting shops, and leaned somewhat towards the table and cross tracks, but the experience I have had since these cranes have been put in has convinced me that shops with longitudinal tracks are preferable.

Our erecting shop is of the longitudinal kind with three tracks, one on each side of the center track, which are used for erecting purposes. The center track is used for disconnecting engines previous to their being placed on the side tracks, placing engines on their wheels after being finished and for putting finishing touches on them.

With the system of longitudinal tracks and electric cranes, there is very little handling of engines. They are taken off the wheels, put on blocks on side tracks, and the wheels are picked up by the crane, put on a car and run to the machine shop. In the case of cross tracks and transfer tables, when the engines

are lifted off the wheels it is necessary to handle the wheels by hand on the table.

Another matter in connection with this is the available room; with the longitudinal tracks it being much less with the cross tracks. In our present erecting shop we can put ten engines on each side track and generally have four or five on the center track, making an average of 24 engines in a space of 377 feet long and 72 feet wide. If we had this number of engines in a shop with cross tracks, it would take at least a space of from 500 to 550 feet long and the same width as the above mentioned shop in order to get around the engines.

HARVEY MIDDLETON,

General Superintendent Motive Power, Baltimore & Ohio Railroad.

Baltimore, April 9, 1898.

Editor "American Engineer:"

Your statements in regard to "Electric Cranes versus Transfer Tables," in your April issue, are rather broad, and I must say that I cannot altogether agree to them. The so-called longitudinal plan in distinction from what might be called the stall plan, has certainly many advantages, but in my opinion it is applicable to shops for new work rather than for repairs. As far as the actual work done on the engines is concerned, I think that better light can be obtained by use of short stalls or pits with an opportunity of better taking care of the material handled without getting in the way of other work. In the longitudinal plan at least one track must be kept clear for its full length in order to get engines out when they are ready, unless it is proposed to pick an engine up and take it over everything else for the full length of the shop—not an easy proceeding and one fraught with considerable danger. Very heavy cranes are needed for this purpose, and a crane large enough to handle a locomotive in such a manner is entirely too large for the greater proportion of the work to be done.

While a transfer table certainly occupies some room, yet a certain amount of such room is needed alongside of the buildings in order to obtain sufficient light. It is not difficult for men to cross a transfer table pit, and it is not necessary or advisable that material should have to be carried across. While a transfer table does not lift the material, it can certainly handle it more quickly than a crane, that is, such material as a truck load of bolts or lumber.

You also lose sight of the fact that very few shops are for locomotive repairs alone, but must take care of passenger and freight cars as well, and that you cannot well handle a 70-foot passenger car with a traveling crane, to say nothing of a freight car as a whole.

I presume you know that we are building new shops, and while we may not be making an entirely "scientific use of the imagination," as we propose to use a transfer table, yet we think that we have an eminently practicable design, as well as one which may be operated very economically. Instead of having several transfer tables, we have but one, and this one is nearly 800 feet long, all of our shops being on this single table, thus overcoming one of the principal difficulties in the average shops, i. e., the getting of material from one group of shops to another except by wheelbarrow. In fact, our plan may be compared with that of one of the modern 20-story buildings if laid on the ground, our transfer table taking the place of the elevators and being used in the same way to furnish almost the sole means of communication between the various departments. This will, of course, be an electric transfer table of comparatively high speed, and there will be a crew on it at all times, just as there would be on an elevator. It will carry not only rolling stock but all manner of materials. Of course, there will be overhead traveling cranes in the shops and they will be lighter and consequently much quicker and better adapted, as I have said, to handle the majority of the work than cranes large enough to lift a locomotive.

TRACY LYON,

Master Mechanic Chicago Great Western Railway,
St. Paul, April 6, 1898.

Editor "American Engineer:"

I may say that I am entirely in accord with the short editorial on electric cranes vs. transfer tables on page 126 of your April issue, but to follow out the suggestions contained it requires a long narrow shop building, and when it is a case of very large

*See "American Engineer," November, 1897, page 365.

capacity the shop becomes extremely and inconveniently long when using parallel tracks. The lay of the ground and the consideration of possible future extension with increase of capacity must be considered when deciding between the two plans of parallel or cross tracks. In 1882 the erecting shops at Roanoke were arranged after full consideration on the plan of parallel tracks, using rope driven overhead cranes, and I recollect having a long discussion with the late Mr. Howard Fry on this same subject in the fall of 1881 with special reference to the use of rope driven cranes for this purpose, electric cranes not then having been developed.

R. P. C. SANDERSON,

Division Master Mechanic Norfolk & Western Ry.
Roanoke, Va., April 13, 1898.

BALDWIN LOCOMOTIVES FOR CHINA.

Editor "American Engineer:"

I think the following items of news will interest your readers:

The Russian Company, of China, has ordered 20 locomotives from the Baldwin Locomotive Works for the branch line from Port Arthur to the main Mandjarin line.

A combination of American contractors is negotiating in St. Petersburg for the construction of wharves and docks in Vladivostok, the eastern Russian port on the Pacific.

A. ZDIARSKI.

St. Petersburg, April 6, 1898.

DRAFTSMEN FROM TECHNICAL SCHOOLS.

Editor "American Engineer:"

I have read the first editorial paragraph on page 126 of your April issue and from my experience I think that there are probably several reasons for the state of affairs you referred to. In the first place the young engineers just out of technical schools are practically of no use in a railroad drafting room. I have had experience with some of them, who were so utterly conceited that they made themselves nuisances. They have no practical experience whatever, or at least to such a limited extent that all you can do with them is to set them at work tracing. With many of them theory predominates and they require so much watching and instruction that they are more trouble than they are worth.

Another reason for our difficulty is that local conditions at the places of employment on railroads are not always of the most pleasant nature, and young men with some experience prefer to go to large cities, rather than to the places where shops are located and where plenty of hard work but little amusement is to be obtained. A man with a half dozen years' practical experience in drawing office and shop, with good common sense and but limited technical education, is generally of much more value to his employer than the man who graduates first in his class, but has no shop experience or drawing office practice. We have a good many applications from men of the latter kind, but I have always felt obliged to decline to engage them.

April 5, 1898.

SUPERINTENDENT M. P.

Editor "American Engineer:"

Your inquiry in the April issue, "Why is it with all the technical schools preparing young engineers, it is so difficult to secure satisfactory draftsmen?" recalls my experience in employing young men just graduated from technical schools. First, they were failures as draftsmen and had to be educated to the business in hand, the defect appeared to have been in their schooling, and was an illustration of the old issue, "Theory vs. practice." The young men appeared to be well posted in the theory of mechanical drawing, and would make a general plan of the machine when they were made to understand just what was wanted, and were surprised when the work was condemned on the ground that it "could not be worked from."

They attempted to show too much; for instance, the plan of a box car would show the outside siding, then the braces and studding would appear in dotted lines, the inside sheathing by other dotted lines; rods and bolts were also dotted, when not to the front, the result being a tangle of lines which no person but the maker could understand. Remonstrance would be met with the indignant remark, "Why, it is all there," which was too true.

In making detail drawings they did not understand the importance of making different views, showing all sides and in-

dicating different kinds of material. In laying out a locomotive frame or car sill showing location of holes, lugs, gains and mortises, the sum total of measurements would sometimes be greater or less than full length of the piece. Of mortises and tennons they knew nothing. It was some time before they could realize that the mechanics who had to work from the drawings were not draftsmen, or mechanical engineers, and that plans must be made that could be read and understood by the ordinary run of shopmen. Where 500 or 1,000 were employed the time of the foremen was too valuable to give more than a brief space to explain plans and hunt out errors. When the young men realized how much there was to learn and what a large world it is, and if they had the energy to work for improvement they in time became valuable men.

Utica, N. Y., April 8, 1898.

JAMES M. BOON.

Editor "American Engineer:"

Allow me to offer the following reasons for the condition stated in the editorial paragraph in your April issue: There are probably a number of reasons for the fact that difficulty is found in securing men for such positions as are there mentioned, among which these may have their influence: The call is, as a rule, for men who have had some experience in the business and who may be trusted to go alone in making plans and in designing machinery. The young man just from an engineering school is usually a fairly good, often an excellent, draughtsman; but he has still to acquire a knowledge of the special line of work in which he is to make himself a place. He is not wanted for purposes of training by those who thus advertise their needs, but to do work involving experience and carrying with it responsibilities which the youth just out of college is unprepared to assume.

On the other hand, once these men do secure their positions, and do acquire so much of knowledge of the special work of an establishment and so much of experience as makes them capable of doing work without nursing, and of accepting responsibilities safely, they are pretty sure to be the men who are the last to be discharged; since they, more than any other class, combine theoretical with practical knowledge, are best fitted to meet emergencies, and to solve new and difficult problems, and thus are not to be found—at least not so frequently—as the less fortunate old-style members of the craft. A good man, fitted by nature for success in mechanical pursuits, for example, with the right business qualities and having a good engineering college training, rarely loses his hold upon business once he secures it. He rarely drifts about very much, and is rarely to be found by those who seek him in the market-place.

There are, as a matter of course, and particularly since engineering courses have come to be considered particularly promising, and especially "chic," many young men, in the aggregate, who go into this work with less fitness for it than for law, medicine, or even the ministry, and they must inevitably fall out again in the process of time and with that evolution that insures "the survival of the fittest"—the fittest to survive, in that branch of industry. But these are probably less numerous, proportionately, than in any other profession; for in no other professional school is the worthless material pruned out so mercilessly and so effectually as in the engineering schools.

As evidence of the probable correctness of this supposition, I may say that I have, for years, been in the habit of keeping two files, the one of letters from graduates desiring positions; the other from would-be employers of this class of men. My file of the first sort contains individual applications in very small numbers; my other file contains letters from employers; and, often, one such letter will contain applications for two or three, and sometimes a half-dozen, men. With our graduating classes—of late years a hundred or more, last year of a hundred and thirty—there is, necessarily and as would be expected, some delay, occasionally, in finding just the right peg to fit each prescribed hole, and now and then an alumnus is thus delayed in finding his first place; but this delay rarely affects more than an exceedingly small proportion of the class, and, once a peg is well fitted in its place, it is apt to stay there, and so firmly that it is difficult for any chance advertiser for assistance to get it out. I have, for now a quarter of a century, been sending out men of this class; my daily mail is made up, in no small proportion, of correspondence with them, but correspondence rarely indicating a displaced peg, and usually simply a friendly note to tell of progress, advancement, success. There must be about fifteen hundred young men in the United States

(not a few in foreign countries and also including a large proportion of the now responsible officers of the United States Navy), on whom I have such claims, and many of them make a point of now and then, often at intervals of years, to be sure, reporting themselves, in person or by mail; but a letter of complaint with fortune or indicating a failure in life is extremely rare.

Possibly the fact that, in all important schools and colleges of this class, the administration is accustomed to keep such files as I have referred to may have something to do with the difficulty mentioned. Mr. Cornell used to say that whenever anything was seriously needed by the university, it might be taken for granted that "the man is walking around, somewhere, who wants to provide it, and whose only difficulty is in finding his way to it." The real problem, in the endeavor to effect the desired result, is that of enabling the two parties to the needed contract to find each other.

In so far as defects of preparation give rise to difficulties of the sort under discussion, they come, usually, of two principal sources: Lack of natural fitness for the business; lack of experience and knowledge of the minor details of the craft. Many a young man can conduct a steam-engine or boiler trial or figure out a "calorimetric analysis," but yet cannot tell what is meant by a "soft patch," or how to start an engine without knocking out a cylinder head, or even how to properly lay off the center lines of his drawing, or to stretch his paper, or to decide whether to use "Whatman's" or brown paper. Such details must come of experience in the apprentice's place, and no man is safe in a higher position until these things are made familiar. "Pride goeth before a fall" is a good proverb to be kept in mind by young graduates. Fortunately, the engineering graduate is exceptionally sensible and modest—if of the right material.

R. H. THURSTON,
Sibley College, Cornell University.

Ithaca, N. Y., April 11, 1898.

RAILROAD CLUB REPORTS.

Editor American Engineer:

A short time ago, one of the technical papers printed a letter criticising one of the railroad clubs for taking up subjects with which its members were not familiar, and as I am a member of all of the clubs I was hit by it and felt somewhat hurt. If we do not talk about matters outside of our regular routine how can we avoid becoming very narrow? I think the author of the letter referred to takes a narrow view of the possibilities offered by the clubs for the broadening influences they possess over the members.

I defend the clubs against such criticisms, but I bring up another matter that is very troublesome to me and that is, in regard to the method followed by some of the club secretaries in printing the proceedings. I understand that there is an association among the secretaries, the object of which is to unify the methods of reporting the proceedings. I object very strongly to the printing of advertisements and texts of proceedings upon opposite sides of leaves of the pamphlets. I object to the appearance of advertisements in the proceedings at all, but especially inside with the part of the pamphlet that is supposed to be devoted to the records of the meetings. This practice can not be defended and it is in such bad taste that I should think many protests would be raised. Who will bind such papers for permanent record?

Another objection that I will raise is to the lack of system in numbering the pages of the annual volumes of the reports. There ought to be uniformity in this respect and each volume should be paged continuously throughout. I speak from the standpoint of one who keeps track of all of the work of the different clubs and as I keep an index of the papers and discussions that I want to refer to again the present practices are annoying. Then I do not see why members want to see so much of the minor detail of the discussions of motions on record. For instance, Mr. Black has not heard from Mr. White, etc. Who wants his book shelves loaded with this?

In order to avoid the appearance of grumbling without suggesting a remedy, I will recommend the club secretaries to examine the reports from the different clubs. They will find in the reports of one of them, it is not necessary to mention which, all of the features I consider desirable and if the reports are worth printing at all they are worth printing in such a way as to make creditable permanent records. It is a pity that at the present time there is only one club whose proceedings are brought out in shape for binding. And yet the discussions before the clubs are worth permanent preservation.

I wonder that the clubs do not see this point, and if you desire and do not consider me too critical you may publish this letter.

April 10, 1898

T.

KEY WAYS IN DRIVING AXLES.

The photograph from which the accompanying engraving was made was taken from a fractured steel, locomotive driving axle which had been running on the Chicago, Burlington & Quincy Railroad from May, 1893, until January 27, 1898, during which time it had made 217,155 miles, and the journals had worn from a diameter of 7 1/4 inches to 6 29-32 inches. This mileage is good and the failure is exceedingly interesting, be-



Photograph of Fractured Axle.

cause it illustrates the great importance of little things in the designing of such parts, which are not to be offset by using the very best of material or by enlarging diameters, even to a considerable extent. In other words failures are not always due to inferior or insufficient material.

In this case the breakage is believed to be due to the form of the key seat for securing the driving wheel upon the axle, and a glance at the fractured end shows that it occurred at the key-way, and probably started at the indentation left by the drill point at the end of the key-way, the drill being used to cut

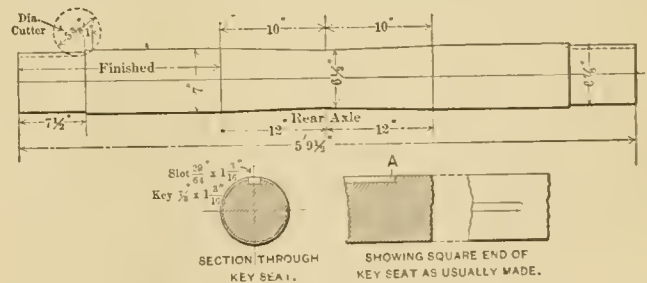

Improved Method of Cutting Key Ways.

out the end of the slot. Key-ways are often cut in this way, a drill being entered at the end of the slot while the key-way is slotted out by a tool that is allowed to "run out" into the drill hole, leaving a sharp shoulder, as shown in the small sketch.

A great improvement has been made in the cutting of key-ways on this road by employing a rotary cutter of the proper width, and the inner end of the slot is left as shown in the drawing of a worn driving axle, for the class "A" and "B" engines of this road. This cutter is 5 3/8 inches in diameter and tapers the end of the slot in such a way as to avoid the sharp corner of the other method. This is a matter of design which appears small at first, but it is clearly of very great importance.

(Established 1832.)

AMERICAN ENGINEER

CAR BUILDER AND RAILROAD JOURNAL.

29TH YEAR.

67TH YEAR.

PUBLISHED MONTHLY

BY

R. M. VAN ARSDALE,

MORSE BUILDING.....NEW YORK

G. M. BASFORD, Editor.

MAY, 1898.

Subscription.—\$2.00 a year for the United States and Canada; \$2.50 a year to Foreign Countries embraced in the Universal Postal Union. Subscriptions for this paper will be received and copies kept for sale by the Post Office News Co., 217 Dearborn Street, Chicago, Ill.

EDITORIAL ANNOUNCEMENTS.

Advertisements.—Nothing will be inserted in this journal for pay, EXCEPT IN THE ADVERTISING PAGES. The reading pages will contain only such matter as we consider of interest to our readers.

Special Notice.—As the AMERICAN ENGINEER, CAR BUILDER AND RAILROAD JOURNAL is printed and ready for mailing on the last day of the month, correspondence, advertisements, etc., intended for insertion must be received not later than the 20th day of each month.

Contributions.—Articles relating to railway rolling stock construction and management and kindred topics, by those who are practically acquainted with these subjects, are specially desired. Also early notices of official changes, and additions of new equipment for the road or the shop, by purchase or construction.

To Subscribers.—The AMERICAN ENGINEER, CAR BUILDER AND RAILROAD JOURNAL is mailed regularly to every subscriber each month. Any subscriber who fails to receive his paper ought at once to notify the postmaster at the office of delivery, and in case the paper is not then obtained this office should be notified, so that the missing paper may be supplied. When a subscriber changes his address he ought to notify this office at once, so that the paper may be sent to the proper destination.

The paper may be obtained and subscriptions if sent to the following agencies: Chicago, Post Office News Co., 217 Dearborn Street. London, Eng., Sampson Low, Marston & Co., Limited St. Dunstan's House, Fetter Lane, E. C.

The usual drop test for couplers is to drop a weight of 1,640 pounds three times upon the guard arm from a height of three feet and give subsequent drops of five feet until the failure occurs. This test, however, is not endorsed officially by the M. C. B. Association, although known as the M. C. B. test. More definite specifications are needed because of the influence of the rigidity or lack of it in the foundation, the amount of yielding of the lower ends of the vertical posts and the security and rigidity of the fastening of the coupler against lateral movement when the hammer strikes it. The weight, size and character of the foundation are equally important, and these factors vary greatly in the different drop-testing machines, and cause variety and unreliability in the results which must operate in an undesirable way as regards the attitude of manufacturers toward improvement. What is needed is an investigation of the subject by the association looking to placing the recommendations with regard to the construction of coupler drop-testing machines and the height and number of drops in the "Recommended Practice" of the association. In the discussion of a paper on "The M. C. B. Coupler," by Mr. Giroux, before the Western Railway Club, in March, Mr. Wm. Forsyth made such a suggestion in the form of a resolution which has the endorsement of the club. The idea deserves attention by the association.

Balanced valves have long been used in this country and with such satisfactory results as to cause wonder that they are not more extensively used elsewhere. Their high standing with American locomotive men probably resulted from tests made ten years ago, which showed that in a series of thirteen experiments the average resistance of a balanced valve was 330 pounds, against 905 pounds for the plain valve, the pressures and speeds being the same in both cases. The balanced valves required but 36.5 per cent. of the force expended upon the plain valves. These figures were published at the time and they have never been doubted, yet balanced valves have not been widely introduced in English practice. There is reason to believe that the balanced idea will soon take root there, however, as a result of tests recently made on valve friction by Mr. J. A. F. Aspinall, of the Lancashire & Yorkshire Railway, who compared plain valves with valves fitted with Richardson balance. He found that "there was considerable advantage in having to overcome a force of only 854.3 pounds for the balanced, as against 1946.2 pounds for the unbalanced valves." We do not believe in crowing about this too much, but Americans should see to it that there is no good thing in English locomotive practice that we do not adopt and if possible improve upon.

It has long been known that China has great natural resources only awaiting the introduction of adequate transportation facilities and capital in order to bring the country to the front among the productive nations, and the number of railroads projected shows that the value of transportation concessions has not been underestimated. In this issue we print an account of the work that has been done, the plans in process, a description of the wonderful resources of the country, and of the scramble after franchises which is now being carried on. This is the most complete article on the subject that has been printed. It is from the pen of the most accomplished engineer in China, who has been long in the field and speaks with authority. It is evident that concessions are difficult to obtain, on account of the bearing of political influences, both within and without China, coupled with the "peculiar" business methods in vogue there, and from the statements of our correspondent it is clear that Americans have not thus far met with encouraging success. Whether franchises are obtained by Americans or not, it is evident that our manufacturers of rolling stock and railroad supplies will find this field worth cultivating, and they should lose no time in securing a large share of the business which is sure to follow the projects already started. There can be no doubt that China is to have railroads, and many of them. Our methods and our unequalled facilities for promptly furnishing equipment and supplies give us every advantage in their development.

THE CLEANING OF TRIPLE VALVES

The Master Car Builders' committee having in hand the subject of "Trains Parting" has probably found that many factors tend to cause trains to break in two on the road and that with the increase in the number of air brakes and automatic couplers the trouble is likely to become more rather than less serious unless precautions hitherto thought unnecessary are looked after. One of these factors is believed to be the cleaning of triple valves. Since the publication of the record that was taken by Mr. Rhodes (printed in our issue of February, page 68 of the current volume), attention has been called by several motive power officers to the importance of insuring that triples are clean. In the article referred to the question was raised as to whether the time limit set by the Master Car Builders' Association of one year between cleanings was not unnecessarily long, but it is now thought that it is not too long, moreover additional evidence comes to light

showing that on some roads at least very few triples are cleaned that often.

In some records that were taken some time ago it was found that the triples of a comparatively large portion of the cars concerned, had not been inspected or cleaned but once in four years. This was not the worst of it either because the triples of these cars were found upon inspection to be in such bad condition as to be dangerous to run and they were known to have caused trains to break in two. It is becoming more and more important to keep brakes in uniformly good condition, not only that quick stops may be made when necessary but also—and this is hardly less important—that the brakes should be applied practically simultaneously throughout the length of the train. If the triple on a car in the middle of the train should lag behind those of neighboring cars a surge of the train is produced that may produce a break, and if several of them are slow in operation, trouble may be expected every time.

It is evident that this danger is not likely to grow less important with the increase in the number of air brake cars and the cleaning of the triples is apparently a matter of increasing importance. A great deal of thought is now given to the best method for handling trains that are partially equipped with air brakes and wide differences of opinion exist as to the best practice. There is reason to fear that very long trains with all the cars braked will not be much easier to handle than the partially equipped trains, and it is believed that the triple valve will need much more careful watching than it has had because of its influence in this form of accident. The air brake has done so much to advance the interests of railroads that the necessary care ought not in fairness to be given grudgingly.

MORE LIGHT ON THE COMPOUND LOCOMOTIVE.

Compound locomotives are making headway in this country, yet the progress is slow, especially as regards passenger service. As this type becomes better understood it will probably grow more rapidly into favor and anything in the form of practical scientific research into its efficiency compared with that of the simple engine is most valuable at this time, when many are studying the economical operation of locomotives so seriously. A paper recently read by Prof. R. A. Smart, of Purdue University, before the St. Louis Railway Club, gives information of this kind and the work appears to have been

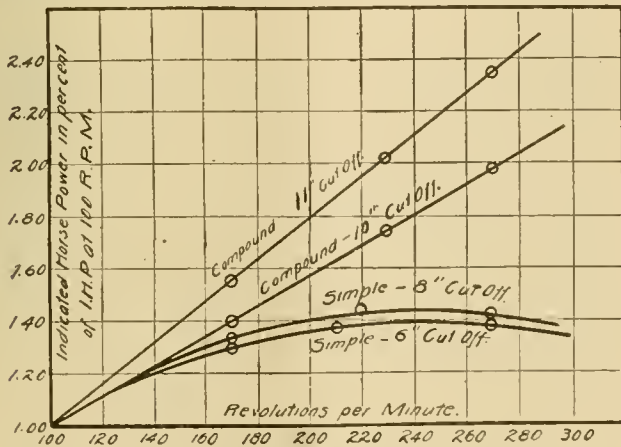

Fig. 1.

done in such a way as to entitle the results to confident acceptance.

The tests were made upon a Vauclain four cylinder compound, which is a part of the laboratory apparatus at Purdue. The purpose was to investigate the cylinder performance at high speeds and to determine in particular the change of power and steam consumption with change of speed. No data on the boiler performance were taken. Two series of tests

were made, one with 4.8 and the other with 4.2 expansions, the speeds ranging from 100 to 270 revolutions per minute, the boiler pressure being 140 pounds for the first series and 130 for the second. The ratio between the cylinders is 1 to 2.88.

Prof. Goss has shown by tests on the simple engine formerly a part of the laboratory equipment, that with the throttle fully open and the cut off constant the power increases as the speed up to a certain point, after which the power does not increase, even though the speed is increased. He has called that speed at which the power ceases to increase the "critical speed," and has shown that the steam consumption per horse power per hour is lowest when the engine is running at the critical speed, from which he

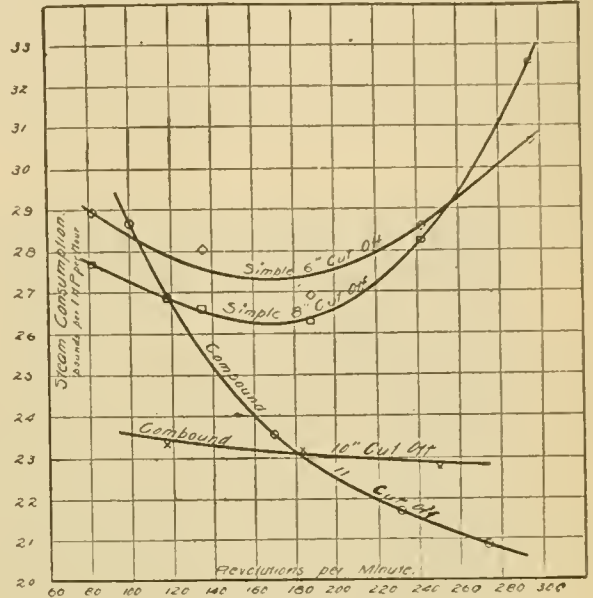

Fig. 2.

concluded that the critical speed is an important factor to be considered in the design of locomotives. This work is of special interest and importance when compared with the conclusion of Prof. Smart in regard to the compound, and instead of the power falling off above a certain speed it increased with the speeds up to the limit reached by the tests.

It has been generally admitted that the compound has the advantage over the simple engine in freight service when train loads become heavy enough to require a longer cut off than is economical in a simple engine, but it has also been generally believed that the compound works most favorably at slow speeds and with heavy loads. Compounds have been thought to lose both power and economy at high speeds and it has been urged that they could not be used indiscriminately in fast and slow service, which probably explains their greater progress in freight service. These tests throw much light upon this question and it appears that it has not been clearly understood.

The relation between the speed and the power of the compound compared with a simple engine is shown graphically in Fig. 1, reproduced from the paper, from which it appears that at 270 revolutions per minute there was not only an increase of power, but there was no evidence that the limit was even approached. The comparison in the economy of the two types as affected by the speed is seen in Fig. 2, and it is important to note that in this comparison the compound was run at a cut off corresponding to freight service, while the simple engine was worked at shorter cut offs. Prof. Smart suggests the probability that if the simple engine had been worked harder the curves of compound would have been at all points below those of the simple engine, which tends to form the basis for a conclusion favorable to the superior economy of the compound under all conditions of running.

Prof. Smart found that the change in the steam distribution in this type of four-cylinder compound gave increased horse power and economy up to 270 revolutions per minute, the limit reached in the tests, and the tendency of the curves indicated that the increase in power would continue for much higher speeds. In this he is supported by data obtained in other tests made on this same type of compound. The increase in power with the speed was due to the steam distribution and the increase in economy was attributed to a decrease in the cylinder condensation, as shown by the quality of the steam at release in the low pressure cylinder. The average steam consumption by the compound was much lower than the lowest consumption by the simple engine, and under exactly comparable conditions probably the compound would show lower consumption of steam at all speeds and points of cut off. It is interesting to see that the economy of the compound was improving at the upper limit of speed, the curves not having reached the minimum points, and this, together with the fact that the power curves of the compound were straight lines, makes it clear that these limits should be exceeded in future tests upon the same lines.

The tests are conclusive as far as they go, but the importance of the subject and the possibilities indicated demand more extensive work of the same kind.

NOTES.

Fireboxes of nickel steel are to be tried in the locomotives on the Prussian Government lines. The thickness will be 7 mm. as compared with copper 16 mm., but the cost will be about the same. Staybolts of nickel steel are also to be tried.

The Santa Fe offered a prize of \$150 to the freight agent on its line who showed the greatest increase in business for the six months ended December 1, 1897, and it has just been awarded to F. J. Gates, who represents the company at Gainesville, Tex.

It cannot be gratifying to engineers in this country, says "Transport," an English contemporary, to be reminded that, when the Russian Government had in contemplation the construction of ice crushing steamers for the trans-Siberian route, a number of experts were sent to the United States to examine and report upon the lake vessels!

The largest tank steamer in the world is nearly ready for launching at the Roach shipyard, Chester, Pa. She is for the Standard Oil Co., and has a capacity of 720,000 gallons of oil. The cost will be \$250,000. The length over all is 254 feet, beam 40 feet, engines 1,500 horse-power and speed 12 knots per hour. The oil tanks are separated from the engine and boiler spaces by wells filled with water for safety against fire. She may use oil for fuel, although this has not been decided.

The qualification of steel for making coupling links was discussed recently before the Western Railroad Club. Mr. I. C. Hubbell, Purchasing Agent Kansas City, Pittsburgh & Gulf, after about a year's use of steel links gave a very satisfactory report of their service on that road. None of the links broke in the weld. Mr. Wm. Forsyth said that he had found steel links to more than meet the specifications required and if of good material and properly welded he preferred them to iron links.

Writing about the utilization of exhaust steam in "The Engineering Magazine," Mr. Bryan Donkin says: "To allow the exhaust steam to escape uncondensed is a disgrace to engineers." Much has been done to save coal, and it is sometimes forgotten that there is the most direct possible relation between coal and steam and hot water. There are many places where the result of installing supply tanks, condensers, circulating and air pumps, and counting also the additional cost of operating the pumps, will be a net gain which will pay for the equipment even in the first year.

Purdue University has a new building in the process of erection which will constitute an addition to the present engineering laboratory. The new portion is 50x100 ft. in size, is located between the steam engineering laboratory and the locomotive laboratory, and is to be connected by passage ways with both of these buildings. The addition is to be known as the railway laboratory, and is the last of the series of engineering laboratories which were provided for in the original plan of the present group. The Purdue engineering laboratory now includes seven large laboratory rooms: A wood-working room, foundry, forge room, machine room, steam engineering laboratory, locomotive laboratory, and railway laboratory.

An undulating grade line, with summits at stations, for service requiring frequent stops has often been suggested and is sometimes ridiculed. An example of this will be seen in practice on the Central London Railway, recently described in "Engineering." Starting out of Oxford Circus there is a level portion of 160 feet, 295 feet of 1 in 30 down; 925 feet of 1 in 622 down; 595 feet of 1 in 60 up, and 160 feet level. At starting the motors exert a draw bar pull of 9,600 pounds for 18 seconds until the 160 feet of level is passed and the down grade is entered, when the acceleration is increased and the drawbar pull reduced to 3,200 pounds. The speed 58 seconds after starting is 24.5 miles per hour, and in 755 feet it must come to rest, 34 seconds being allowed for this.

The depression of rails under heavy locomotives and the increased fibre stress in the rails caused by the neglect of apparently small precautions was very well illustrated by Mr. F. A. Delano in a recent paper before the Western Railway Club. He showed that merely changing from gravel to cinder ballast, and increasing the weight of a locomotive 15,000 pounds increases the strain on the base of the rail from 10,450 pounds to 13,810 pounds, a difference of 3,360, or an increase of 32 per cent. The removal of a tie from a track laid with a 66-pound rail supported on oak ties and gravel ballast increases the strains produced by an engine weighing 125,000 pounds from 13,810 pounds to 16,430 pounds, an increase of 2,620 pounds, or 19 per cent. This shows the evils of removing a tie for drainage purposes, which is a practice not uncommon with track men. It seems a small thing to remove only one tie, but in the light of these figures it is really a serious menace to the life of the rail from which it is removed.

Trolley railroad competition with steam roads is becoming serious, as is indicated by the report of the Massachusetts Railroad Commissioners, in which it is stated that if the present rate of building is kept up the trolley lines in ten years will have a greater mileage in the State than the railroads. There were carried last year on the street railways of the State in round numbers 308,700,000 passengers—an increase of 16,300,000 for the year. This was, however, a marked falling off in the rapidity of growth of traffic as compared with 1896, when the increase of passengers was in round numbers 32,600,000, and still more as compared with 1895, when the increase was 39,300,000. The average increase since the introduction of electric motive power (in 1889) had been 20,600,000 a year, and for the five years next preceding the last, had been 23,300,000 a year. The decrease in the number of passengers to and from Boston on the four leading suburban lines of steam railroad for the four years from 1893 to 1897 was 12 per cent. for all the companies, one road having lost 22 per cent. The corresponding gain in traffic on five competing trolley lines for the same period was 31 per cent., and one of these lines showed a gain of 155 per cent. in that time. The transfer of the business is not attributed to any neglect on the part of the management of the steam roads. It is the result of well understood changes in the conditions of such transportation which the steam roads are unable to control.

THE HOLLAND SUBMARINE BOAT.

Great interest is now centered in the submarine torpedo boat recently built by Lewis Nixon for the John P. Holland Torpedo Boat Company, and now undergoing trials in the vicinity of New York. Mr. Holland has been working on this problem for about 20 years, and this boat is the sixth built by him. This one is 53 feet long, 10 feet 3 inches diameter, and has a displacement of 75 tons. Another is now building in Baltimore, the dimensions of which are 85 feet long by 11½ feet diameter and 168 tons displacement. The hull is shaped like a cigar, with a peculiar superstructure flat on top.

The hull is of steel plates, riveted to a steel skeleton frame. Amidship is a conning tower, 2 feet in diameter, so made as to extend from two to three feet high, or telescope flush with the hull. Within the hull, immediately below the conning tower, are the two tillers, one for surface sailing, the other to regulate the depth at which the boat is operated when submerged, and the speaking tubes, electric bells, and a table connected with apparatus for manipulating a camera lucida, used



The Holland Submarine Boat.

when the boat is submerged for portraying the appearance of the surface. The view is secured by means of a steel tube thrust above the water and fitted with camera apparatus. There are three sources of energy for propelling the boat above and below the water, expelling water, discharging torpedoes and dynamite guns, and lighting the ship internally and externally; these sources are compressed air, gasoline and electricity.

The important agent is compressed air, without which it would be impossible to operate the boat under the sea. The air compressor was built by the Ingersoll-Sergeant Drill Co. It is of the single acting type, belt driven from a gasoline engine, when the boat is on the surface, and from an electric motor switched to a storage battery, when the boat is submerged. The compressor is capable of compressing air to 2,500 pounds pressure; the diameter of the low pressure cylinder is 6 inches, the high pressure cylinder is 1¾-inch diameter, with 8-inch stroke. Both cylinders are immersed in a water box, which cools the air during compression. Solid discs serve for fly wheels. The space occupied is only six feet five inches long, by two feet high. The most important use of the compressed air is for the respiration of the crew, numbering ten men. For this purpose the air is expanded through two reducing and one regulating valve, and is set free at the normal atmospheric pressure.

Six times the requisite volume of air is available; the surplus air is used for counteracting the deleterious effects of the ventilating pumps, which would produce a near approach to a vacuum, if the air supply from the tanks was interrupted in its even flow. The steering and driving gear are operated

by compressed air, which also maintains the air pressure throughout the boat to equalize the pressure of the sea when the boat is submerged. The boat is quickly submerged by admitting sea water to a series of steel tanks connected with the compressed air system. When the commander signals to elevate the boat from the depths, air is forced into the water tanks under high pressure, and as the water is expelled the boat rises swiftly to the surface. The air tanks have been tested to stand a pressure of 3,000 pounds to the square inch, and are calculated to hold out for a submergence lasting ten hours, but if the supply should fail after nine or ten hours the tanks can be replenished by means of a tube projected to the surface as a suction pipe.

The armament of the boat consists of one dynamite gun, one automobile torpedo tube, and one aerial torpedo tube. These tubes and gun are made effective by the use of compressed air, which not only enables the torpedo and gun operators to hurl torpedoes and great masses of dynamite with precision and force, but immediately restores to the boat the weight of 800 to 1,000 pounds lost when a projectile or mass of dynamite

is discharged. The muzzle energy of the dynamite gun is 750 tons.

The trials show a speed of 10 knots, with the conning tower flush with the surface, and under water speeds of 6 knots have been made for distances up to a mile, the depth of submergence being about 15 feet.

The performances of this boat are very promising, those of the projectiles not less so than the working of the boat itself. We acknowledge the courtesy of the Ingersoll-Sergeant Drill Company for the engraving.

MONITORS VS. BATTLESHIPS.

The preference for the monitor type of war vessel is very strong among those who have fought in them and now contemplate the high free board and large target areas offered by modern battleships. In a recent address, Lieutenant Moses S. Stuyvesant expressed an opinion of the monitor in the following terms, which is well worth quoting:

"What is the matter with the monitor, that those who design our ships and who do not go to sea in them must have battleships? The two-turreted monitor is a fighting ship par et simple, stripped to the waist, and has no solar plexus. She does not require a man of cast steel to get out of her all she is capable of. Her main deck is only 12 to 16 inches above water, presenting an armored target that high, and about 270 feet long. On top of this are two low turrets, containing each two heavy rifles. On top of them is a light superstructure, in which are a few light guns for repelling boarders, torpedo boats, etc. With equal guns she can whup any battleship afloat."

American Society of Mechanical Engineers.—The next meeting of this society will be held at Niagara Falls, N. Y., May 31 to June 3.

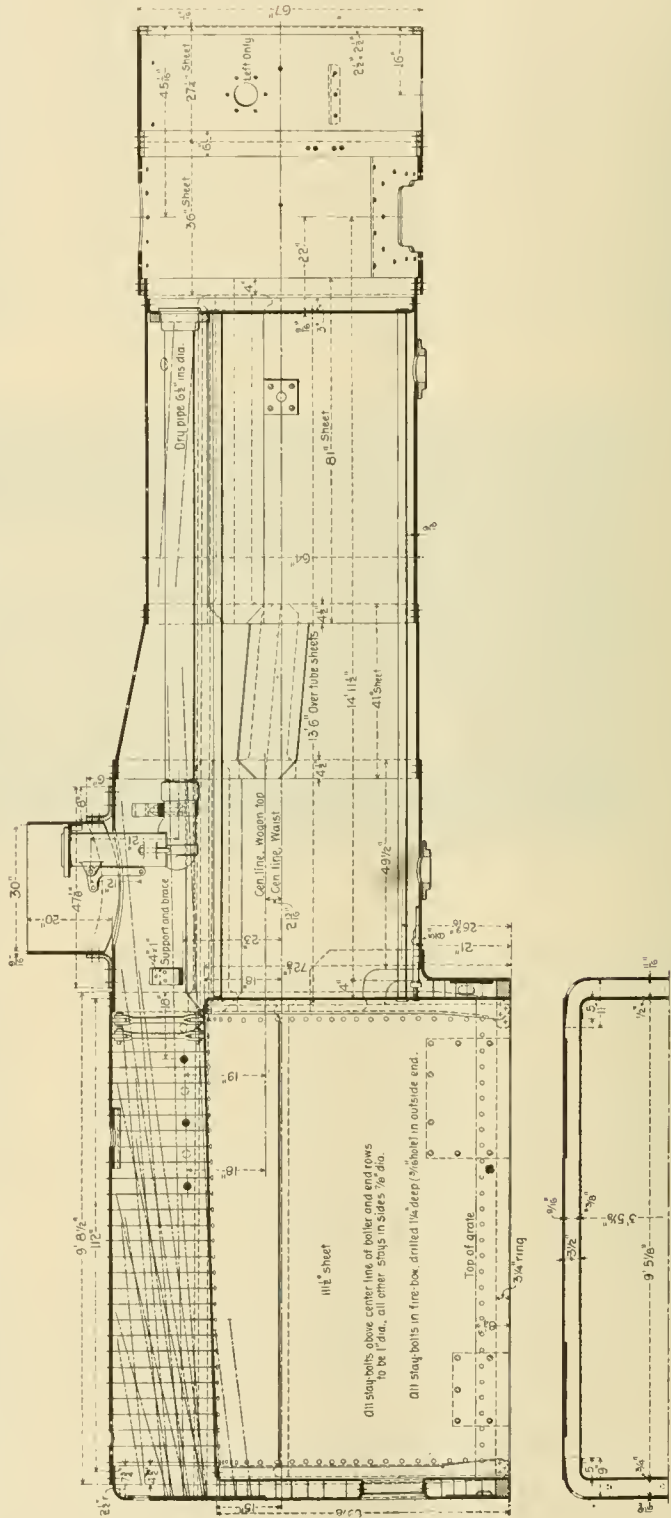
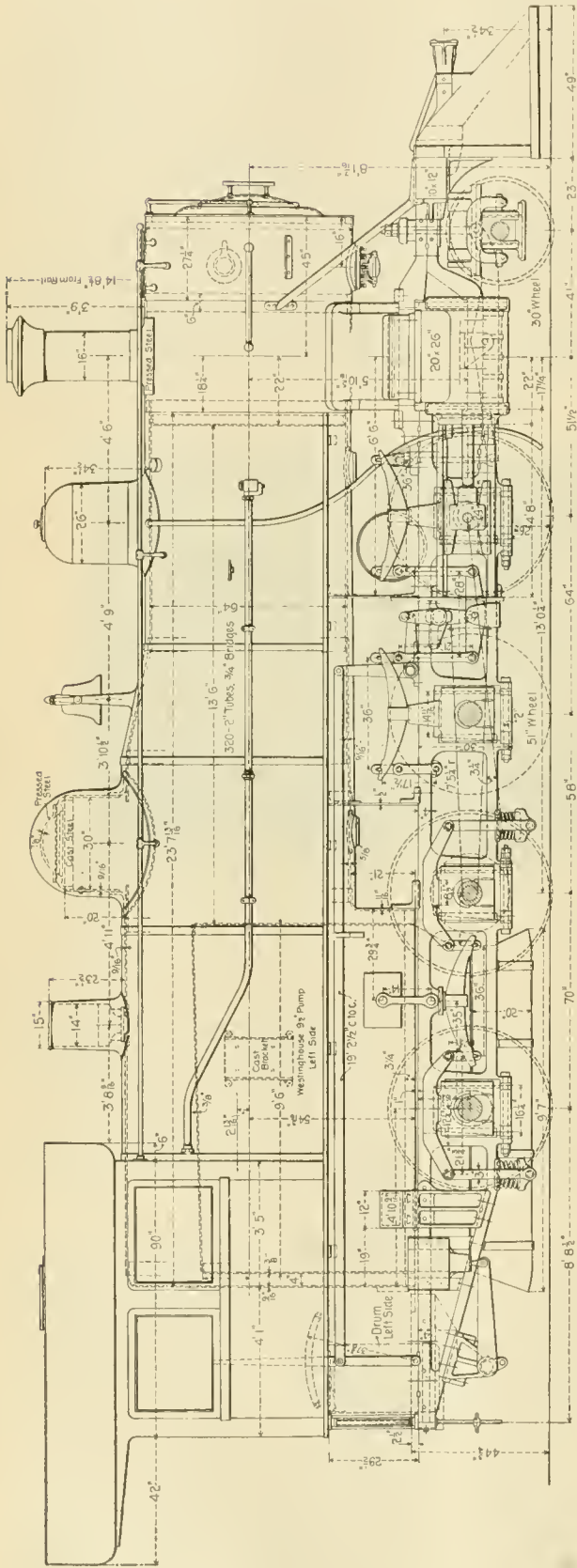

CONSOLIDATION LOCOMOTIVE-CLEVELAND, CINCINNATI, CHICAGO & ST. LOUIS RAILWAY.

RICHMOND LOCOMOTIVE AND MACHINE WORKS, BUILDERS.

WILLIAM GARSTANG, Superintendent of Motive Power.

TRIAL CONSOLIDATION LOCOMOTIVE—C., C., C. & ST. L. RY.

A new single expansion freight locomotive has just been delivered to the C., C., C. & St. L. Ry. by the Richmond Locomotive Works, and is now in service giving excellent results which lead to the expectation that more will be built from the same drawings and specifications. The illustrations show the chief features of the design, which may be enumerated as follows:

The engine has 20 by 26-inch cylinders, 51-inch drivers, an extended wagon top, radial stayed boiler, long main and eccentric rods (the eccentric rods are I section), a long deck in the cab, and large coal and water carrying capacity. The firebox is above the frames. The engine weighs 150,500 pounds, with 134,650 pounds on drivers, and was designed with the expectation of hauling one-third more tonnage per train than was handled by the heaviest freight engines in use on the road previously. The records show that the new one hauls trains of 1,500 tons as compared with 1,050 tons for the other, these trains being hauled up grades of 45 feet per mile, the weights being taken for the train and caboose only. The fuel performance is 0.09 pound of coal per ton mile, as shown by the records of the road. The heating surface of the boiler is 2,431 square feet, and the grate area 35.23 square feet, giving a ratio of 69 to 1 between the heating surface and the grate area.

The engine has the Leach track sander, Monitor injectors, Janney couplers on both ends, Westinghouse air brakes and springs by the A. French Spring Co.

The general dimensions are given in the following table:

Gauge	4 feet 8½ inches
Kind of fuel to be used	Bituminous coal
Weight on drivers	134,650 pounds
“ truck wheels	15,850 pounds
“ total	150,500 pounds
General Dimensions	
Wheel base, total, of engine	23 feet 8½ inches
“ driving	16 feet 0 inches
“ total (engine and tender)	51 feet 5½ inches
Length over all, engine	42 feet 2 inches
Height, center of boiler above rails	8 feet 1½ inches
of stack	14 feet 8 inches
Heating surface, firebox	171.05 square feet
“ tubes	2,260.00 square feet
“ total	2,431.05 square feet
Grate area	35.23 square feet
Wheels and Journals.	
Drivers, number	8
“ diameter	51
“ material of centers	Cast steel
Truck wheels, diameter	30 inches
Journals, driving axle, size	8½ by 11 inches
“ truck	5¾ by 10 inches
Main crank pin, size	6 by 6½ inches
Cylinders.	
Cylinders, diameter	20 inches
Piston, stroke	26 inches
“ rod, diameter	3½ inches
Main rod, length, center to center	30 feet 1½ inches
Steam ports, width	20 inches
“ length	1¼ inches
Exhaust ports, length	20 inches
“ width	2½ inches
Bridge, width	1¼ inches
Valves.	
Valves, kind of	Richardson balanced
“ greatest travel	5½ inches
“ outside lap	¾ inch
“ inside lap or clearance	0 inches
Boiler.	
Boiler, type of	Extended wagon top
“ working steam pressure	190 pounds
“ material in barrel	Carbon steel
“ thickness of material in barrel	9-16, ¾ and 1-16 inches
“ diameter of barrel	64 inches
Thickness of tube sheets	¾ and 9-16 inch
“ crown sheet	¾ inch
Crown sheet stayed with	Radial stays
Dome, diameter	30 inches
Firebox.	
Firebox, length	9 feet 6 inches
“ width	3 feet 5½ inches
“ depth front	72 3-16 inches
“ back	69 3-16 inches
“ material	Carbon steel
“ thickness of sheets	¾ inch
“ No brick arch	
“ water space, width—	
“ Front, 4 inches; sides, 3½ inches; back, 4 inches	
Grate, kind of	Rocking and drop

	Tubes.
Tubes, number	320
“ material	Charcoal iron
“ outside diameter	2 inches
“ length over sheets	13 feet 6 inches
	Smoke-box.
Smokebox, diameter	67 inches
“ length	67 inches
	Tender.
Swivel trucks	
Tank capacity for water	1,500 gallons
Coal capacity	12 tons
Type of under frame	Wood
Truck bolster	Rigid
Type of truck springs	Elliptic
Diameter of truck wheels	36 inches
Diameter and length of journals	5 by 9 inches

Personals

Mr. Sheldon T. Bent has resigned as Superintendent of the Inter-oceanic railway of Mexico.

Mr. J. Kruttschnitt has been elected Fourth Vice-President of the Southern Pacific, a newly created office.

Mr. H. Walter Webb, Third Vice-President of the New York Central & Hudson River, has resigned on account of poor health.

Mr. J. G. Justice has been appointed Master Mechanic of the Plant System, at Waycross, Ga., succeeding Mr. D. B. Overton, resigned.

Mr. J. G. Thomas has been appointed Division Master Mechanic of the Lehigh & Susquehanna Division of the Central of New Jersey.

Mr. Frank Slater has been appointed Master Mechanic of the Chicago & Northwestern at Escanaba, Mich., vice Mr. J. W. Clark, resigned.

Mr. W. L. Hoffecker has been appointed Division Master Mechanic of the New Jersey Central Division of the Central Railroad of New Jersey.

Mr. Percival Roberts, President of the A. & P. Roberts Co., proprietors of the Pencoyd Iron Works, died at his home in Philadelphia March 30.

Mr. Raymond Du Puy has been appointed General Superintendent of the Chicago Great Western, succeeding Mr. Cornelius Shields, resigned.

Walter Dawson, formerly for many years Master Mechanic of the Delaware, Lackawanna & Western, died in New York, April 12, at the age of 75 years.

Mr. Frank W. Edmunds, for many years General Sales Agent of the Troy Steel Company, has been appointed Secretary of the I. & C. Co., of Chicago.

Mr. W. C. Holfman has been appointed Master Mechanic of the Chicago & Southwestern, with headquarters at Lebanon, Ind., succeeding Mr. J. W. Roberts.

Mr. W. F. Beardsley, Master Mechanic of the shops of the Pennsylvania lines at Allegheny, Pa., has had his jurisdiction extended over the Erie & Ashtabula Division.

Mr. J. Van Dell, formerly with the Chicago & Alton, has been appointed Master Car Builder of the Chicago, Rock Island & Pacific, to succeed Mr. L. T. Canfield, resigned.

Mr. C. H. Beggs, Secretary to the Vice-President and General Manager of the St. Louis & San Francisco, has also been appointed Purchasing Agent, with office at St. Louis.

Mr. W. H. Newman, Second Vice-President of the Great Northern, has been selected for the Presidency of the Lake Shore & Michigan Southern, to succeed Mr. Callaway.

Mr. George Tozzer, who has been Assistant Purchasing Agent of the Cleveland, Cincinnati, Chicago & St. Louis, has been appointed to succeed the late Mr. A. M. Stinson as Purchasing Agent.

Mr. Charles A. Van Keuren, formerly Superintendent of maintenance of way of the West Shore railroad, has been appointed Chief Engineer of the street and water board of Jersey City, N. J.

Mr. J. W. Harkom has resigned as Master Mechanic of the Eastern Division of the Grand Trunk at Montreal to accept the position of Assistant Mechanical Superintendent of the Canadian Pacific.

Mr. Charles P. Coleman, General Storekeeper of the Lehigh Valley, with office at Packertown, Pa., has resigned to accept the position of Purchasing Agent of the Bethlehem Iron Company, South Bethlehem, Pa.

Mr. H. S. Stebbins, General Manager of the Bath & Hammondsport, and the Lake Keuka Navigation Co., has resigned and his duties will be assumed by Mr. C. W. Drake, President of both companies. Mr. Charles J. Drake has been appointed Superintendent.

Mr. Chauncey M. Depew has retired from the Presidency of the New York Central & Hudson River to take the Chairmanship of the Boards of Directors of the Vanderbilt lines, comprising the New York Central & Hudson River, the Lake Shore & Michigan Southern, the New York, Chicago & St. Louis and the Michigan Central.

Mr. W. G. Collins, who for the past seven years has held the position of General Superintendent of the Chicago, Milwaukee & St. Paul, has been appointed General Manager, and will relieve Mr. A. J. Earling of the duties of that office. Mr. Earling has been Second Vice-President and General Manager since 1895, and was appointed General Manager in 1890.

Mr. S. R. Callaway, President of the Lake Shore & Michigan Southern, has been elected President of the New York Central & Hudson River, to succeed Mr. Chauncey M. Depew. Mr. Callaway began his railroad career in 1863 as clerk in the Auditor's office of the Grand Trunk, and his rise has been steady to his present high position. He succeeded the late Mr. D. W. Caldwell as President of the Lake Shore last Summer.

Mr. William G. Creamer, who was well known to our readers as a valued contributor, died at his home in Brooklyn, April 22, at the age of 72 years. He was a pioneer in the development of the air brake giving control of the train brakes to the engineman, which work he was engaged upon in 1856. He is also widely known on account of his attention to the subject of passenger car ventilation. He leaves a widow and one daughter.

NEW INGERSOLL-SERGEANT AIR COMPRESSORS.

Fig. 1 shows the type of air compressors recently introduced by the Ingersoll-Sergeant Drill Co., known as Class "H," which is furnished either in half duplex for the future addition of the second half or in the duplex form. It is built with both steam cylinders non-compound or is arranged as a cross-compound, and with air cylinders either compound or non-compound. In duplex compound the usual capacities are 80, 210, 346 and 519 cubic feet of free air per minute. It is a very compact type, being designed to occupy a very small space.

The duplex construction, generally used where the demand for air fluctuates, offers a marked advantage in regulation. The machines have ball governors to prevent excessive speed

in case of air pipes bursting, and in combination with this is a throttling regulator, causing the machine to work at the speed which is necessitated by the demand. The duplex machine is slightly more economical than the straight line, because of the heavier fly wheel and also because of the greater advantage which may be taken of expansive working; also the high pressure side may be used alone if the low pressure side is disabled.

Compounding on the air side is advocated because of the reduction in the loss through heating the air in single expansion. Besides the losses excessive heat makes lubrication difficult. In this machine the air in passing from the low to the high pressure cylinder comes in contact with cooling surfaces in an inter-cooler, the saving from which may be expressed as from 15 to 20 per cent. of the power required in compressing.

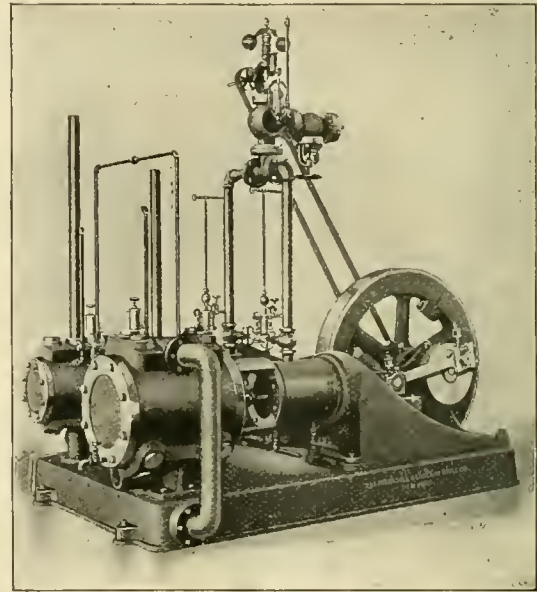

Fig. 1 Class "H" Compressor.

The wearing of the parts is improved by the use of this plan, because of the ease of lubrication and the reduction of the maximum stresses.

In a duplex compressor the maximum stresses from the steam and air cylinders are what may be termed cross stresses, which require rigidity in the fastenings of the cylinders in order to keep the machine in line and to avoid high internal friction. The sole plate of this machine is exceedingly rigid and is in itself a foundation for the machine, not requiring an expensive substructure, a few mud sills being a sufficient support. The sole plate in this type of compressor is utilized as an inter-cooler, the interior construction of which resembles that of a surface condenser, in which the cooling surface consists of a large number of tubes through which water circulates. The cooler is so constructed that it may be removed and entirely exposed for cleaning in a few minutes.

The air cylinders have ample intake passages, the valves are light in weight and are so made that in case of a broken stem they cannot be drawn into the air cylinder. Provisions are made for drawing the air from out of doors. The inlet valves are placed under the cylinders where they have ample lubrication. The clearance spaces are very small and the air passages are so arranged that the incoming air is not brought into contact with hot metallic surfaces. Deep stuffing boxes are used, completely water jacketed, adapted to the use of loose packing. The air cylinders are completely water jacketed, including the heads, this being possible on account of the location of the inlet valves under the cylinders.

The steam cylinders of all sizes are covered with sheet metal,

carefully packed with non-conducting material. In all sizes smaller than 12 by 12 inches a special economical light running slide valve is used, located so that the exhaust constantly drains the cylinder. The ports are large and short. In sizes

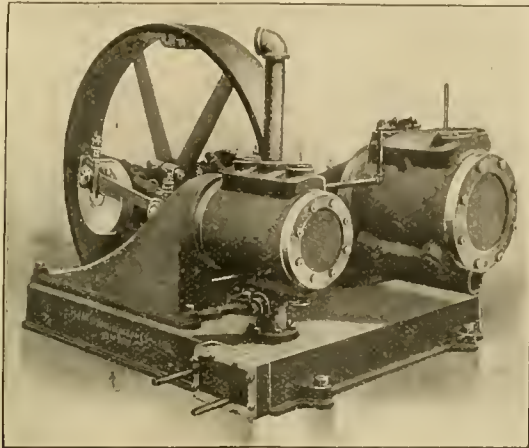

Fig. 2.—Class "J" Compressor.

12 inches or larger, the Meyer expansion valve gear is used, allowing early cut-offs without compression.

The bearings are babbitted and made adjustable for wear and are of large diameter. The fly wheel is made in halves, and is very heavy. A great deal of metal is put into the ma-

In Fig. 2 a duplex belt compressor, known as Class "J" is illustrated. It is furnished in capacities corresponding with the Class "H" machine, and the description already given will make its construction clear. The sole plate is shortened and the air cylinders are bolted to the Tangye bed plate, instead of to the steam cylinders, while the fly wheel is displaced by a belt pulley. Owing to the stresses due to the four discharges of air per revolution in a duplex machine the belt pull is much steadier than in a single machine, and as the terminal strains are greatly reduced by compounding, the duplex compound type gives the best results, owing to the nearly uniform belt pull.

The regulation of a belt machine, the speed of which must be constant, is an important matter, and in this machine the Sergeant unloading device is used, which regulates the work by drawing back a sufficient number of the discharge valves at each end of the air cylinder, giving a by-pass for a portion of the air. Upon the fall of the pressure the load comes back gradually and we are informed that the regulation is entirely satisfactory. This compressor is entirely automatic in its action and has an inter-cooler.

In Fig. 3 a view of a Class "C" Corliss compressor is shown, having 24¼ by 42 inch air cylinders, the photograph being taken from a compressor now working at the Aurora mine, Ironwood, Mich.

PHILADELPHIA & READING RAILWAY—SHOP NOTES.

The principal shop plants of this road are at Reading, Pa. The rolling stock repairs, excepting those made at the division roundhouses, are all done at Reading. The road has 19 roundhouses, some of which were formerly used also as the

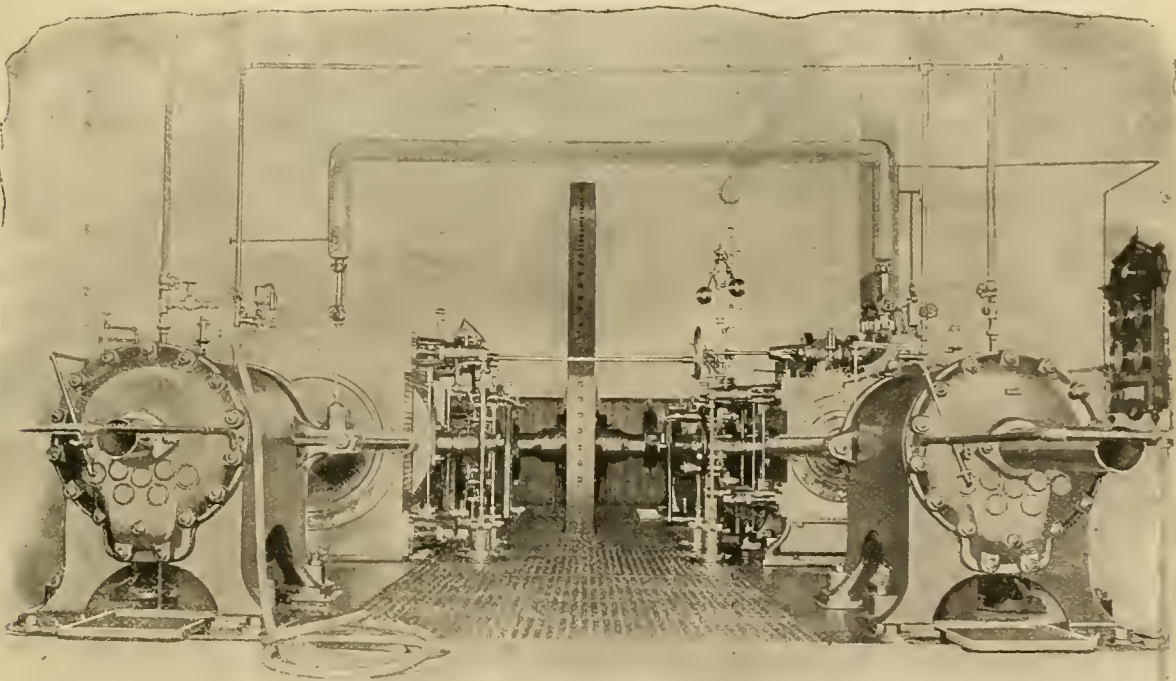

Fig 3.—Class "C," Compound.

chines, making them rigid and strong, with little liability of getting out of line. The type was designed especially for manufacturing, railroad shop and mining requirements. This is a very recent design and represents the best development by this firm for the service intended.

repair shops of the roads which now form the Reading system, and these old shop equipments are now utilized to relieve the pressure of work at the Reading shops. The largest of these roundhouse plants have drop pits, and facilities for giving general repairs to about eight engines per month, and in case

of accident at the main shops the roundhouse plants could be used to very good advantage.

Eight hundred and fourteen locomotives are maintained at Reading, the number of men at present employed there being 950. The capacity of the shops and the two largest roundhouses is 45 engines per month for general repairs. At Reading 52½ hours per week are now made, and 56 engines are in the shop. These are practically all in the immense erecting shop, which is about 180 by 375 feet in size.

Locomotive Shops.—The Reading locomotive shops cover a large area, and are divided by a street and by the main tracks into three parts—offering a tempting layout for a system of electric distribution of power. Liberal use of Westinghouse engines is made in the forge and boiler shops, which have great advantages over long lines of shafting. All of the shops are roomy, and most of them are very well lighted, and generous floor space is provided, a very unusual thing even in the most recent plants. The floors are clear of material, and it is a matter for wonder where all of the material and the parts undergoing repairs are put. They are not allowed to litter up gangways and floors and are replaced on the engines at the earliest possible opportunity. Mr. Davis believes in clean, orderly, systematic work, and the attention he gives these matters evidently pays. The shops and roundhouses are white washed twice a year, and efforts are made to make the surroundings of the men attractive.

The most recent purchases of tools show a disposition to secure large capacity. Among these a large Acme bolt-header was seen in the forge shop, and a No. 5 combined punch and shear by Hilles & Jones in the boiler shop. A new Ingersoll-Sergeant air compressor has been set up in the engine room of the boiler shop and foundry, and for the four cupolas an old fashioned upright blowing engine and two rotary blowers are used. The chief interest in the blowing engine is the example of good old designing in the way of ample ports and passages.

It would be interesting to go into details as to the various shops and the foundry, but space limits the description to a few principles of operation, which are being carefully studied and practiced. The maximum output for the minimum expense is sought after and many machines are now running without exclusive individual attention. The man who runs the stationary engine in the erecting shop also runs a drill press nearby, and the same idea is carried out in various parts of the works. The concentration of all of the work of certain kinds for the whole system in these shops is good business management, and it is evident that the parts of the plant given to such departments are the busiest of all, which looks like getting good returns for investment. The brass work, including finishing and plating, are examples of this. In the plating department a simple machine for polishing the reflectors of headlights after they are silver plated is working without any attention whatever. A very hard, steel burnisher is held by a rod suspended by a spring from the ceiling, and is given a vibratory motion by a crank and connecting rod driven by a belt. The reflector is held in a socket and slowly rotated by a worm gear, while the burnisher polishes the surface with a lubricant of soap and water. It runs all day without attention. The organization in these shops is very complete, and is unique in that there is no general foreman or Master Mechanic in charge. Mr. Davis gives his personal attention to all departments. The shop seems to "run itself," and the object in view was to arrange and plan the work so carefully as to permit of competition with manufacturers in all classes of work done.

Piece Work.—About 40 per cent. of all the locomotive repair work is done on the piece work plan, it is also used in erecting work, but to a smaller extent. Great care is given to the establishment of the piece work prices, and the system is satisfactory alike to the men and the officers. A feature of the system, new to us, is to put the finishing of certain parts under the piece work system, while the preparatory operations are

done by day work, the effect of which is to cause the piece workers to urge the day workers to furnish material promptly in order that the advantages of the piece rates may be obtained. The plan operates admirably, its effect being to improve the day work to correspond with the piece work, the urging being done by the men themselves rather than by the foremen. In fixing the piece work prices the work is given to a good man, who works under the direction of the foreman, and the prices are established so carefully as to lead the men to seek the piece work. It must be successful for the men like it, and the output is greatly increased to the advantage of the company.

Appliances.—The tool room for the large erecting shop is admirably supplied with gages, among which are trams and gages for setting shoes and wedges. Long T iron gages are used for setting the shoes, and a corresponding set of trams is used for rod work, the object being to save the trouble of trying the rods in fitting them up. After the frames are in place the main shoes are made square and the other shoes are set by the long gages, after which the wedges are marked from the shoes by means of short gages. The rod work is done in another shop, and the rods are not tried on the wheels until completed. Another tool room kink is the system of taps for wash-out plugs in the boilers. There were over a hundred different sizes of plugs in use before a plan was put into use requiring only 12. Each tap is divided by horizontal lines about one inch apart, and each section of the tap has a number stamped thereon, which exactly corresponds to a mud plug having the same number. The man who taps out a mud plug hole notes the number on the part of the tap that fits the hole, and calls for a plug bearing that number, which is sure to fit. Time as well as stock is saved by this simple improvement.

A link grinder operating in the machine shop is interesting because it requires no calculation for the setting of the link. An old planer was fitted with a long projecting slotted arm to receive the pin at the center of the link circle, and the link vibrates about this center, which is formed by measuring the link radius back of the link arc. This machine was working unattended. It cannot fail to do correct and accurate work.

Arrangement of Machinery.—The tendency to group all tools of one kind, such as lathes and planers, together is noticeable in many shops, but at Reading the arrangement is made solely to suit the work, and to save the services of laborers in carrying the material about. By a few changes in tool locations 30 laborers have been dispensed with, and a plan very much like those followed by manufacturing concerns has been adopted.

In the rod work, benches, two shapers, one bolt lathe, one boring mill, one drill press, one planer and a hydraulic press are provided, all in the same room, are conveniently arranged for handling the work by overhead travelers, and the entire rod job is conducted with no transferring whatever. Car brasses were formerly taken from the brass foundry (about two blocks) to the machine shop for boring, they were carried back to the foundry for lining and back again over the same route to the storehouse upon completion. By putting the machine close to the foundry the cost for labor in finishing was reduced 50 per cent. Accounts are kept for each department, making it possible to tell what it costs to do any portion as well as the whole of any job. The cost of labor lost on defective work is charged against the department that is at fault, which is a specially good check in the case of the foundry. The changes in locations of tools apply to about 25 per cent. of the machine tools at Reading, and the work is cheapened as well as accelerated thereby.

Standardizing Locomotive Parts.—A systematic effort to standardize parts of the locomotives has resulted already in a saving of \$50,000 in the amount of material carried in stock at Reading, and this is one of the greatest improvements that is being made, and is next in importance to the saving of fuel. The most important of the improvements may be noted as follows: Of 19 shops no two used the same taps for water

bars and washout plugs; 16 different styles and sizes of cylinder cocks were changed to one standard; 24 number-plates changed to one; 98 lengths of engine feed hose changed to one (there were sometimes three different lengths of hose on the same engine); 20 tender brake shoe patterns were discarded for one; 11 blow-off cocks gave place to one; 144 sizes of mud plugs were reduced to twelve; the spring list was reduced 50 per cent., with a prospect of cutting the remainder in two; over 100 different eccentrics and straps were reduced to three; 12 styles of engine truck brasses and boxes are reduced to one style and two sizes, 5 by 8 and 6 by 8 inches; 21 different exhaust pipes used on a single class, numbering 64 engines, represent the condition as to these parts, this class and five others are now provided for by a single standard pipe, and three pipes answer for all wide firebox engines.

THE ACME HEADING AND FORGING MACHINE.

This machine, built by the Acme Machinery Co., of Cleveland, Ohio, has an exceedingly strong and heavy bed, made in the form of a box, with three deep trusses extending longitudinally, which are braced by a truss extending across the machine transversely, besides which the fly wheel bearing is reinforced with a steel beam.

The shaft, which is iron, has a clutch hub and two double disk cranks forged in one piece, and is carried in three large bearings, the faces of which are inclined at an angle of 45 degrees toward the front of the machine, which is done to bring the thrust of the forging tools directly against solid metal instead of against the caps. A tool steel pin is fitted in a mortise of the clutch hub, it engages with a cushion clutch

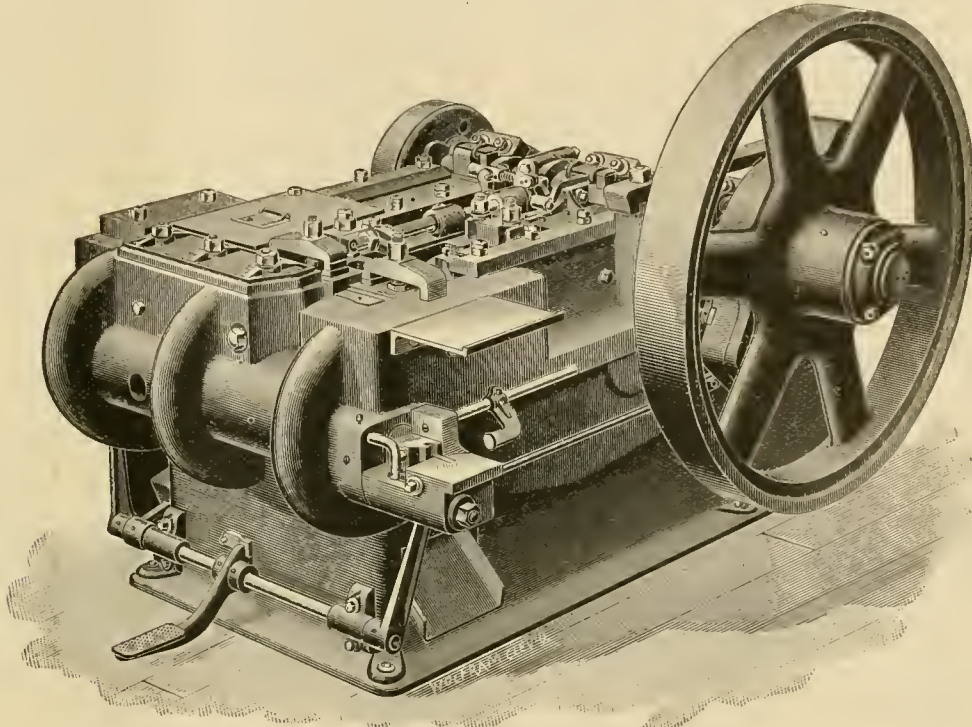

Acme Heading and Forging Machine.

Many other roads ought to take up this subject as systematically as the Reading has done.

Fuel Saving.—The importance of saving coal, even in a section where its cost is relatively low, is fully appreciated, and efforts are made to use the fuel to the best advantage. The consumption of fuel on the road is being studied and one of the efforts to reduce unnecessary waste is explained in the following explicit circular, which Mr. Davis kindly allows us to print:

To All Men in Charge of and Handling Locomotives:

The practice of running the air pump when unnecessary and allowing steam to escape through the safety valve must be avoided as much as possible. Special care must be taken while waiting at a station, on a side track, or at the engine house.

Example—The amount of fuel and water consumed per hour for running a 9½-inch pump is 70 pounds of coal and 60 gallons of water; equivalent to 4 cents. The amount of fuel and water consumed per hour for a safety valve blowing is 870 pounds of coal and 750 gallons of water; equivalent to 45 cents.

If each engine is allowed to waste fuel one hour per day, which is about the average, 700 engines will consume per month, 9,870 tons of coal and 17,010,000 gallons of water, at a cost of about \$10,300.

The responsibility of this waste rests wholly on the men handling the engine.

E. E. DAVIS,
Assistant Superintendent of Motive Power.

stop motion controlled by a foot treadle and is automatically released when the treadle is raised. The object of this is to permit of giving any desired number of blows and by throwing in the treadle latch the machine will work continuously.

The fly wheel has a bronze bushing, which gives good wearing and smooth running qualities, and permits of rapid repairing. The slides have ways of phosphar bronze, side gibs of cast iron, running on hardened tool steel ways in the bed, and all these parts may be easily and quickly renewed when they become worn. Cast steel is used for the stationary and movable die blocks as well as the toggle block, while the toggles are of forged steel and hardened. These parts are all given ample bearings and they rest on steel ways after the manner of the main slides. The arrangement is such that no reciprocating parts wear on the bed. The machine has an outside shear that will shear cold stock to a diameter of one-half the rated capacity of the machine, and when the stock is hot it will shear to three-fourths of the rated capacity.

The machine is provided with an automatic relief and adjustable time device, consisting of a spring in the slide that moves the links, which in turn close the gripping dies. The spring has the least power at the beginning of the motion and the power increases with the motion on account of the position of the links until it ends with the dies in the closed position when the grip cannot be released. If the stock should get caught in the dies in feeding, or if an obstruction accidentally

comes between the dies, the yielding of the spring will prevent the toggles from locking or coming to their centres, which relieves the machine from unnecessary strain.

The time device regulates the length of the interval during which the dies remain closed. The movement of the connecting rod in closing the dies may be regulated by an adjustment for setting up the spring, so that the dies will remain closed for a longer or a shorter interval as desired for the work and the size of stock that is being used. This is a new feature in these machines and the adjustability of the length of closure and the relief features constitute an important improvement. Five sizes of these machines are built, viz.: 1, 1½, 2, 2½ and 3 inches.

THE SCHMIDT SUPERHEATING SYSTEM.

In nearly all steam superheating systems using temperatures above 250 degrees (482 degrees Fahrenheit) serious troubles have arisen from burned tubes, separated joints, leakage and expensive renewals, and these troubles are accompanied by wastefulness in the firebox. These difficulties may be avoided by a construction which insures perfect circulation of the fire-box gases about a large and properly arranged heating surface. The circulation of the steam in the tubes has much to do with the success of the superheater. One of the best means to avoid the burning of the tubes is to arrange them in a manner to obtain a very rapid circulation of the steam in the tubes, and a circulation relatively slow of the gases of combustion around the tubes. By these means the steam has a cooling action on the tubes, the temperature of which cannot much exceed that of the steam itself, while the gases of combustion are rapidly deprived of their great excess of heat by the tubes which are nearest to the fire-box.

An example of this was found at the local exposition at Nuremberg, where an ice machine of the Linde system, intended to make ice for a skating rink, was driven by a steam engine, using highly superheated steam, constructed by Mr. W. Schmidt & Co. at Aschersleben.

This engine was at the same time to furnish power for a portion of the electric lighting of the exposition. This service required continuous running, and this plant did not shut

raise steam with impunity to those temperatures, it behooves one to study especially both the superheater and the motor; with a steam engine of the present type, continuous running would be absolutely impossible under these conditions. In the plant with which we are now occupied, the evaporating apparatus is composed of two vertical boilers AA, with crossed boiler tubes BB, and a central chimney C. The heating sur-

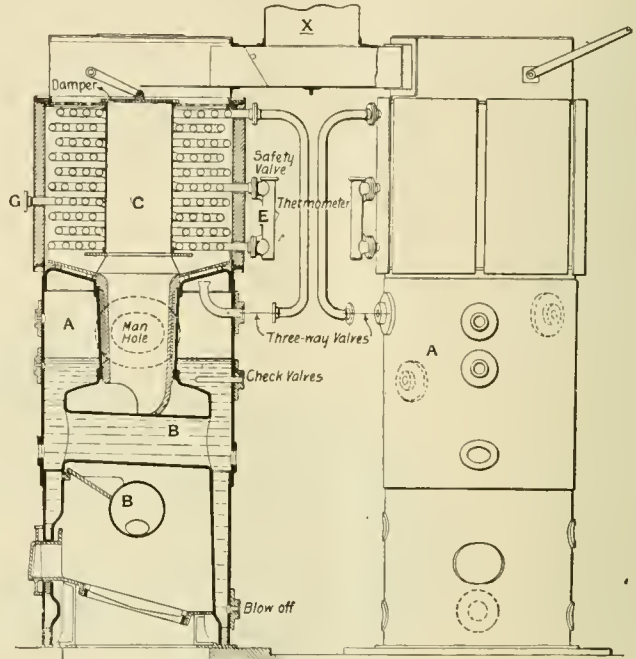

Fig. 1.—Generator and Superheater.

face of each boiler is only 7 square meters, the grate surface 0.52 meters, being for the two boilers together 14 square meters and 1.04 square meters respectively. It is to be seen that the heating surface is small in comparison to the grate surface, from which there is a very great production of steam

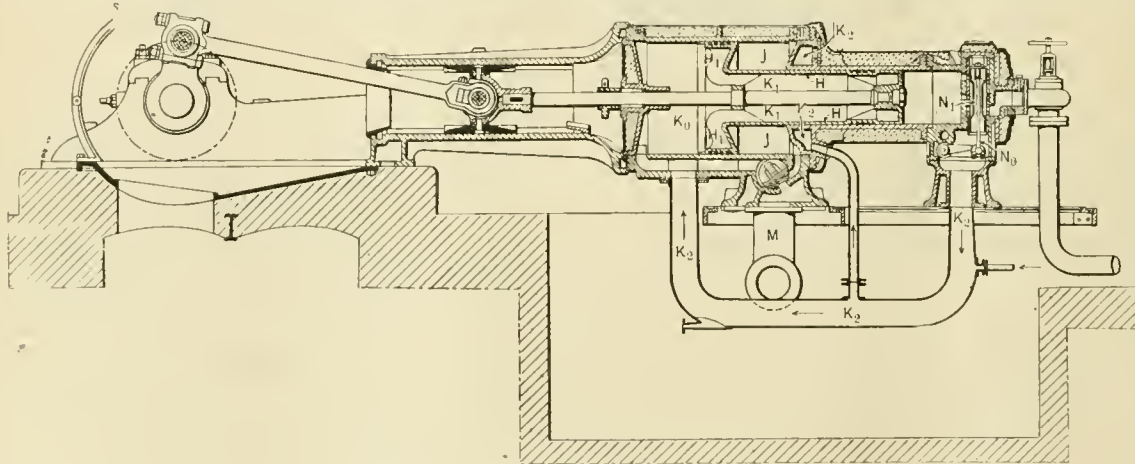

Fig. 2.—Engine for Superheated Steam.

down day or night from the opening of the exposition in June until the closing, on the first days of November. The generators and steam superheaters are shown in Fig. 1, and a diagram of the 100 H. P. motor is shown in Fig 2.

We believe also that Mr. Schmidt was the first, and up to the present time, perhaps the only one, who has realized in practical working the employment of steam raised to temperatures neighboring 350 degrees to 380 degrees (662 and 716 Fahrenheit). It is certain that by these means a great degree of economy has been obtained, and it is also certain that to

for each square meter of heating surface. The production of steam reaches nearly 40 kilograms of steam per square meter of heating surface. It is evident that the gases of combustion must enter the chimney at a very high temperature. If these boilers were not surmounted by superheaters they would make a very poor showing.

The steam produced by such great activity is naturally very damp, but that property is utilized, on the one hand, to obtain a good utilization of the combustible with a heating surface relatively small, and on the other hand, to prevent the burning of the serpentine superheater. The superheaters are composed of a series of steel tubes rolled in flat spirals. Two rows

Translated for the American Engineer from "Portefeuille Economique des Machines."

of spirals are made in one piece and joined to the following ones by coupling-boxes placed outside. The dismantling is thus rendered very easy. The collective heating surface of the spirals is 50 square meters. The steam after leaving the boiler enters directly into the highest of the spirals, D, and circulates rapidly in a direction contrary to that of the gases coming from the fire-box. The damp steam has a strong refrigerating action on the hot gases which escape into the chimney which is common to the two boilers. These gases, in this manner deprived of the greatest part of their heat, are still available for draft.

If this methodical circulation (in contrary directions) was maintained through the whole course, the highly superheated steam going out of the bottom of the serpentine, the steam running through the lower spirals would be very hot and absolutely dry. In this manner the last spiral which is nearest to the fire-box would be continually in danger of being burned and could not fail of being quickly deteriorated, above all under the action of a somewhat lively fire. And besides that, it would necessitate a very large heating surface to reach the desired temperature. To avoid these difficulties Mr. Schmidt changed the direction of the circulation of the steam at a determined point. After having run through six spirals from the top downward, the steam is nearly dry but not yet superheated. It then passes into a cast-iron connecting pipe, E, entering immediately into the lowest spiral, that is to say, nearest the fire-box. As the steam is then still relatively cool, it prevents the deterioration of the lower rows, and, circulating in the same direction as the hot gases, that is to say, upward, it quits the serpentine definitively at the temperature of 340 to 360 degrees (664-680 degrees Fahrenheit) to go to the motor by G.

The motor, Fig. 2, has several special features. It is a horizontal Corliss compound condensing engine. The two cylinders are tandem, acting on one common piston rod. The principal dimensions of this engine are: Small cylinder, 360 mm.; large cylinder, 750 mm.; speed, 80 turns per minute. The air pump is actuated by a pin at the crank pin and a lever. The peculiarity of this engine consists in that each cylinder is single acting, but the whole together works as a double acting engine. It will be seen that the two pistons are united in a single differential piston, HH. The small piston, H, is very long; it is a hollow plunger. The annular or ring-shaped space J, formed behind the large piston, H_o, is the low pressure cylinder. The space, K_o, in front of the two pistons, the hollow part, K₁, of the small piston and the pipes K₂, connecting the back of the small cylinder with the front of the large cylinder, form the receiver. The steam acts at first on the rear surface of the small piston, H, during the forward stroke. At the same time the steam contained in the intermediary receiver, K^o K¹ K², passes into the annular ring space, J, by the admission valve of the low pressure cylinder, L, (circular valve). There is then equilibrium, or nearly so, on the two faces of the annular piston. At the end of the forward stroke the small cylinder empties into the receiver, the low pressure cylinder, J (annular space), communicates by the circular valve, L, with the condenser, M. There is then equilibrium on the two faces of the small piston, but on the annular ring piston there is the vacuum of the condenser and the pressure of the receiver in front. In this manner the backward stroke is effected.

The aim of this peculiar arrangement of the cylinders is to avoid too great an elevation of temperature of the cylinder and of the piston receiving the superheated steam from the boiler. In fact, if the small cylinder was double acting, the walls and the piston would not be long in attaining a temperature which would render all lubrication impossible. In the actual arrangement, the period of exhaust, as well as the steam at low pressure, in the hollow part of the small piston, prevents this super-elevation of temperature. At the same time the steam in the receiver and the walls of the large cylinder are reheated in a very efficacious manner. The engine is well studied from a thermometrical point of view.

In order to avoid a super-elevation of the temperature of the slide-valve of admission the steam in escaping passes by the interior of this valve. In the engines of most recent construction of the Schmidt system, the distribution is made by valves, and this last precaution becomes unnecessary. Let us observe, besides, that the packing-boxes are all situated in places where there is only steam at low pressure, which assures perfect tightness. The engine is of a very solid construction and the frame rests entirely on the foundation, except as to the slide-bars.

The first trials made with this machine after an uninterrupted run of five months, of which we have spoken above, were conducted by the engineers of the "Association Bavaise de propriétaires d'appareils à vapeur." The results were remarkable. They showed a consumption of 1.41 pounds of coal per horse power per hour, and consumption of 9.9 pounds of steam per horse power per hour. These results coupled with the prolonged and uninterrupted running at Nuremberg, abundantly proves the Schmidt system of super-heating to be a success and they show it to be applicable to many industries.

The fact that the different automatic couplers given in the latest Government statistics as being applied to the car equipment of the United States, number an even one hundred is noted by the "Railway Master Mechanic." This is the number for the year ending June 30, 1896. There are twenty-seven others which appear in records of previous years, but which are not set down as in use in the year named—evidently dropped out, at least for the time being. There are also records of 181 cars, having automatic couplers "unclassified." Of the 100 definitely specified 42 are on more than 100 cars each; 23 are on more than 1,000 cars each; 16 are on more than 5,000 cars each, and 9 are on more than 10,000 cars each. There are a few that go to higher figures—to the twenty and thirty thousand point—and two that go far beyond the one hundred thousand point.

The superiority of American over English mechanics was the subject of a recent letter from John Burns, the well-known labor member of the British House of Commons, to the London "Times." He testifies to the excellence of American engineering workmanship and says: "Cheap wages are not the cause. On the contrary, high wages produce that result. Neither are the hours worked a contributing factor thereto, as they are similar. It is not due either to the superiority of the American mechanic as a craftsman in the engineering trade, as they are generally of British parents or British engineers, often members of British unions, who, attracted by higher wages and similar hours, form, as I know by personal experience, the nucleus of American engineering industry. What it is due to is that the American employer has fewer deadheads to carry about, and his captains of industry are more inventive, more adaptable and assimilative, less hidebound in their methods, less prejudiced in their conceits, and more versatile in their inventive initiative."

UNITED STATES HOTEL AND THE CONVENTIONS.

It will please the friends of the United States Hotel, Saratoga, to know that the proprietors have decided to open the house in time to accommodate such of the members of the Master Car Builders' and Master Mechanics' associations and others attending the conventions in June who desire to stop there. The quiet and dignified comfort of this well-known house will be appreciated by many.

WESTINGHOUSE APPARATUS AT THE BOSTON TERMINAL.

The new Southern terminal railway station at Boston is a good illustration of the scope of the Westinghouse manufactures. The switch and signal system are provided by the Union Switch & Signal Company; the engines by the Westinghouse Machine Company; the Westinghouse Air Brake Company will equip the rolling stock and all the electrical apparatus will be supplied by the Westinghouse Electric & Manufacturing Company. The electric installation is to comprise 1,000 horse power of dynamos and motors. The station, when completed, will be the finest in the country. Electricity will be used for lighting, for driving pumps, ventilating fans, etc.

THE HOEY DRAFT ATTACHMENT.

The draft attachment illustrated by the accompanying engravings was designed and patented by Mr. M. J. Hoey, foreman of Car Department of the Columbus, Hocking Valley & Toledo Railway. This device has withstood the test of time, having been in use on 4,300 cars on the road referred to, and it has been in service upon some of them for more than three years, during which time it is reported to have given entire satisfaction. Mr. Hoey recently stated, in a communication to us on the subject, that it is indorsed by the officials of the road and also by the trainmen. It is now being applied to 500 new box cars, which are under construction for this road. Mr. Hoey says:

"There are several features about this attachment which recommend it. The spring and follower pockets are made of malleable iron, and are securely fastened to the draft sills by bolts (plainly seen in the engravings), each side of the pocket being one continuous piece of malleable iron. The diagonal straps on top and bottom act as braces for the timbers, and also provide an inclosure, which prevents the follower and spring from falling out in case of a breakage. The safety key is 1 by 3 inch iron, and is independent and free from strain unless the tail pin breaks, when the strain is thrown on the safety key, and it then comes to a bearing in the slot and hauls

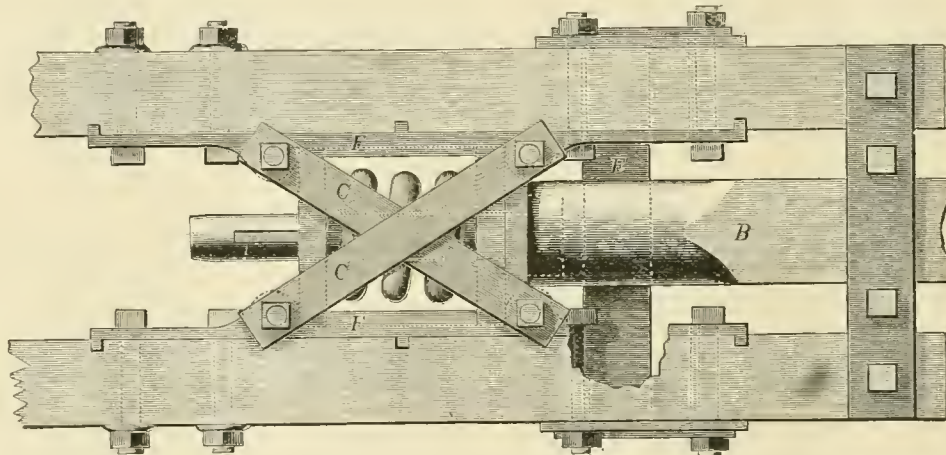

The Hoey Draft Attachment.

the train to its destination. We have now on record 20 cases of this kind, where trains were so hauled, the length of train being 50 cars, loaded with coal, the gross tonnage being in excess of 1,700 tons. The C., H. V. & T. Ry. Co. is, without doubt, hauling as great, if not greater, tonnage per train than any other company in the country, and I claim for the attachment that the test it has been given here for the past three years should recommend it to any railway company desiring to adopt a safety device at a minimum cost."

No change in draft timbers is required for the application of this device, and tail pins may be used without fear of the couplers pulling out and falling upon the track to cause wrecks or damage to brake beams. The safety bar or key shown at E in the plan view passes through a slot in the coupler shank for the purpose of holding the coupler in place in the event of the breakage of the tail pin, as referred to by Mr. Hoey in his letter. This safeguard against the breaking of tail pins should reduce the number of break in twos. It is stated by the manufacturer, The Dayton Malleable Iron Company, Dayton, Ohio, that 18,000 of these attachments are now in use.

BOILER AND STEAM PIPE LAGGING.

During the past few years a great advance has been made in the protection of steam pipes and boilers from radiation of heat, and it may now be said that the importance of this in stationary and marine practice is generally recognized and provided for. The same progress has not been made in connection with locomotives, but it is not to be admitted that this is because such provisions are not equally desirable in

the latter cases. Probably the real importance of good and thorough lagging of locomotives is not appreciated. It is rather difficult to apply lagging to locomotives, except to the circular portions of the boilers, yet if it was considered necessary a way would be found to envelop the whole engine. The writer takes the ground that it is advisable to provide much better protection than is now thought necessary, and it is to be hoped that the committee appointed to report to the Master Mechanics' Association in June will speak in positive terms upon this point.

It is customary to put some kind of lagging upon the barrels of locomotive boilers; it is often of wood, which is far from being a good protection from radiation, and is a source of great annoyance and expense. Some roads are using good lagging on their boilers, but the majority do not even lag the boiler as completely as it might be done. Cylinders are also sometimes protected, but this is not yet to be considered common practice, and aside from an occasional application of lagging to the steam pipes of air brake pumps, these are all of the parts that are ordinarily protected.

As to kinds of lagging little need be said except to point out the fact that the difference between a bare surface and one that is lagged with any respectable covering is much greater than between the best and the worst of the coverings in their effect upon radiation. It may be said in passing, how-

ever, that asbestos is thought by good authorities to be very much overestimated as a non-conductor of heat. Professor Ordway, in reporting upon this material as an insulating substance, said: "By reason of its fibrous character, it may be used advantageously to hold together other incombustible substances, but the less the better." In a list of 32 steam pipe coverings, Professor Ordway places four at the head of the non-combustible substances, all of which are formed with magnesia, which is clear proof of his opinion of this substance as a non-conducting covering.

The reasons why all of the surfaces of the boiler, steam chests, cylinders and the saddles of locomotives should be lagged are sufficiently apparent to need no emphasis. It is so easy to protect cylinders that this ought never to be omitted, a good method of applying the covering so that it may be removed with the outside casing, as used on the Chicago & Northwestern Railway, was illustrated in the "American Engineer" of April, 1896, page 64. A method of protecting the water legs of boilers and the back heads, as used for a number of years by Mr. Geo. W. Stevens of the Lake Shore & Michigan Southern, was fully illustrated in the report of the Master Mechanics' Association for 1885, page 106. This is no new idea, and that Mr. Stevens continues the practice after all these years is good evidence that he thinks it pays. It seems strange that no attempts, so far as the writer knows, have been made to jacket the cylinder saddle castings, and there is no doubt that a great deal of power is lost on account of the

condensation due to the exposure of these large castings as they are pushed through air at zero, or below, at sixty miles an hour. Some attempts have been made to surround the steam passages in the saddle castings with insulating material, but why should not the saddle castings themselves be lagged? Is it a question of appearance, as one Master Mechanic has suggested, or is it merely because no one has thought it necessary?

To sum up: The surfaces that might be lagged are the boiler, the sides and ends of the fire-box (as far as may be reached); the cylinders, including the heads, and the steam chests, and the cylinder and saddle castings—than which no parts carrying steam are more exposed—and the air pump pipes and feed pipes. All this may be done so that the covering may be removed and replaced. The removable covering may be applied to the fire-boxes, as in the plan shown on page 78 of the March, 1898, issue of this journal.

The first question to be decided is whether all this is necessary, which is to be ascertained only through comparative tests. The effect of the protection of all of these parts may be known by running two locomotives, in the same service, through a winter, one of them being fully protected and the other having only the usual amount of lagging. The power of the fully protected engine would probably be much greater than that of the other, because of the great loss of power that must follow the condensation of the steam in the saddle passages. If the coal records are kept with care and accuracy there should be no difficulty in ascertaining any marked advantage of the lagging.

Tests of the relative merits of various different insulating materials may be made by preparing different locomotives of the same class with the same thickness of the various coverings, by raising the same steam pressure in all of the boilers, with all of the fires in the same condition, and allowing them all to stand the same length of time in an inclosed space, where there are no air currents. The dampers and the smokestacks should be closed, and after the fires are drawn the gage pressures should be read at regular intervals. The gages should first be tested, and care should be taken to have all of the conditions alike for all of the boilers. The pressures taken every half hour and plotted on curves would give a comparison that would be valuable and instructive in showing the relative insulating powers of the various materials. It has been noted at the locomotive laboratory at Purdue University that the earlier experimental locomotive "Schenectady No. 1," with wooden lagging, when the fire was drawn at 5 p. m., would lose its pressure by midnight, whereas the new "Schenectady No. 2," which has magnesia sectional lagging, under the same conditions would hold its steam and have some pressure left in the morning. Much might be said in this connection as to the relative advantages of the two laggings when the locomotives are running through a winter storm, with the temperature at some point below zero.

Good lagging costs more than poor, yet it is not very expensive, and if it increases the power of an engine when power is most needed it is sure to be a good investment. It seems probable that we shall some time look back to the present time with wonder that the general use of an improvement so easy of application as lagging should have been so long delayed.

A. E.

APPARATUS FOR TESTING MOUNTED AIR HOSE.

By Oscar Antz.

While it is not a universal practice to subject air hose to a test pressure after being fitted up, it is nevertheless desirable that this should be done, and with the present practice of splicing hose which has become partly defective it is necessary to apply a test to insure having perfect work. The engraving illustrates an apparatus which has been found to answer very well for this purpose, and with it one man can test a hose thoroughly in less than half a minute.

The air pipe supplying the test pressure is provided with an ordinary cutout cock having a $\frac{3}{8}$ -inch hole drilled in the side of the chamber and plug, forming a three-way cock, by means of which air pressure can be applied to the hose and released at will. A gauge is connected to the supply pipe. Below the three-way cock is located a one-inch hose coupling having a one-inch pipe thread cut on the shank, which is screwed into an elbow and in connection with another elbow can be placed at a proper angle so that a hose coupled to it will lie in a horizontal position. The nipple of the hose to be tested is closed and made tight by means of a piece of rubber turned in a lathe to the shape shown. This is held by the nut of a union screwed on the male part of the union. To hold the hose so that this rubber can be forced against its ends, a fork shaped piece of metal is provided which fits into the space between the back of the hexagonal part of the nipples and the hose clamp, which space is usually from one-fourth to one-half inch. This fork is made of a piece

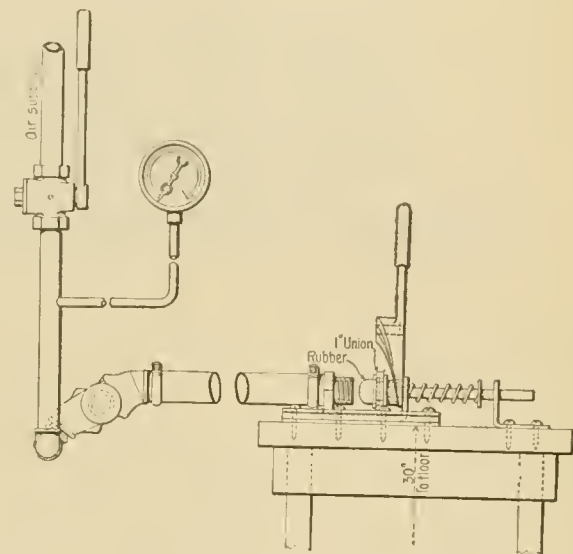

Air Hose Testing Apparatus.

of $\frac{3}{8}$ -in. sheet steel and is bent in such a shape that the base projects at the two sides, so as to slide in guides fastened to a table, to adjust its position to varying lengths of hose. On the end opposite the fork is a flange against which a wedge bears for forcing out the rubber against the hose nipple. A continuation of this flange forms a fulcrum for the operating lever of the wedge. This wedge is made circular and has a slot through the centre which keeps the union holding the rubber plug from turning. The pipe end of this union is plugged with a piece of iron into which is screwed a piece of $\frac{1}{2}$ -in. round iron to act as a guide; the back end of this part of the union is tapered at the sides to the same pitch as that of the wedge; the centre being allowed to project so as to work in the slot of the wedge. A spring on the guide rod bearing against a washer and pin brings the union back against the wedge when this is raised.

The operation of testing a hose consists in placing the coupling end into the stationary coupling, then dropping the nipple end over the fork and pressing down the lever of the wedge, which forces the rubber against the nipple, making a joint which is tight against a pressure of 100 pounds per sq. in. or less. Pressure is then applied and released by means of the three-way cock. Leaks in the hose or fittings are found by an application of soapsuds.

It is reported that the Spanish mackerel have been ordered out of American waters.

NEW CARS BY THE J. G. BRILL COMPANY.

COMBINATION CAR FOR ELECTRIC ROADS.

In our March issue one of the cars by the J. G. Brill Company, now running on the Buffalo & Niagara Falls Railway, was illustrated. These cars were mounted upon Brill "Perfect" passenger trucks, and the present illustration was made from a photograph of a larger and much heavier car for high speed service on suburban lines, on the Ballston Terminal R. R. of Ballston, N. Y., using trucks of the same type. It is a combination car, having platforms and steps similar to those on

service to be maintained with a very small expense for wages. Only two men are needed to operate the car, which is intended to offer the same accommodations as local steam trains. The weight of the car, including 200 H. P. Westinghouse motors and the Christensen air brake equipment, is 60,000 pounds.

TRAILERS—N. Y., N. H. & H. R. R.

The New York, New Haven & Hartford electric motor cars have frequently been illustrated and described, but the almost equally interesting trail cars, which are hauled by the motor cars, seem to have had little attention. The accompanying



Motor Car for the Ballston Terminal R. R.

cars of steam lines. Both ends are vestibuled, and the interior is divided into two compartments for passengers and baggage.

The length over end panels is 25 feet 4 inches, the width being 8 feet 4 inches. The passenger compartment is 16 feet long and seats 22 persons, the baggage compartment is a little less than 9 feet. The latter is sheathed with tongued and grooved boards, and is provided with 4 ft. sliding doors at each side, an end door and a door to swing into the passenger compartment; this door is fitted with glass sash. The platforms are 4 feet 6 inches wide, and the roof is of the regular passenger car pattern, two trolley poles and boards are pro-

vided so that the car may run in either direction. There are two sand boxes, two gongs and gates to the vestibules. There are six windows on each side of the passenger compartment, which is fitted with cherry slat seats; drop seats are also placed in the baggage compartment for use in case of crowding, and for the accommodation of smokers. Altogether the car is as comfortable and convenient as could be desired for use on a road where high speeds are needed between stations separated by short intervals. Cars of this type enable a frequent train

photograph shows one of these cars ready for service, built by the J. G. Brill Company, and mounted on ordinary passenger car trucks. It is 39 ft. 4 in. over the dashers or crown pieces, and 7 ft. 6½ in. wide at the posts. The width over the steps is 9 ft. 8 in. The distance between truck centers is 25 ft. 6 in. There are fourteen benches or seats, ten of which have reversible backs, the other four have stationary backs against bulk heads at the ends. The car is furnished with an ordinary monitor roof, and the curtains at the sides are arranged to come all the way to the floor, going outside of the ends of the seats. This is made possible by the use of the Brill round end

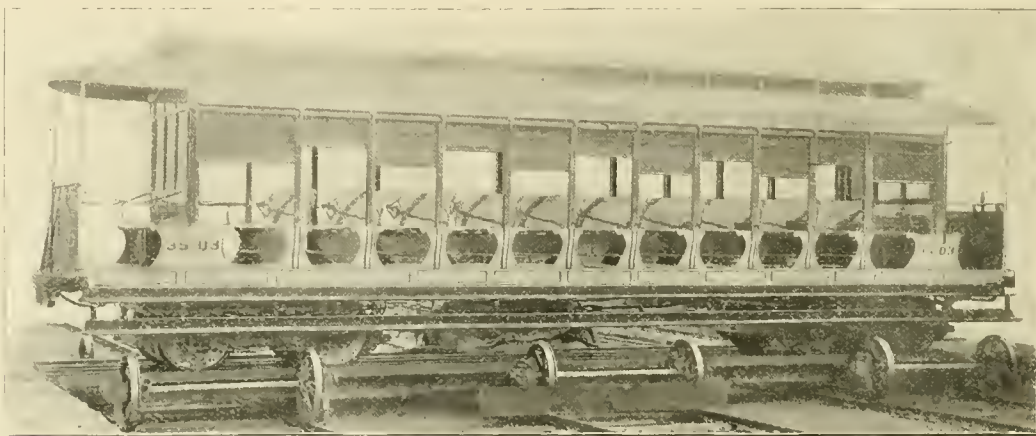

Trailers for the N. Y., N. H. & H. R. R.

vided so that the car may run in either direction. There are two sand boxes, two gongs and gates to the vestibules. There are six windows on each side of the passenger compartment, which is fitted with cherry slat seats; drop seats are also placed in the baggage compartment for use in case of crowding, and for the accommodation of smokers. Altogether the car is as comfortable and convenient as could be desired for use on a road where high speeds are needed between stations separated by short intervals. Cars of this type enable a frequent train

seat panel, which in addition to the ordinary curvature is fitted to the seat with a round end so that the projecting corner, which usually interferes greatly with the lowering of the curtain, is out of the way. The curtains are of pantasote. The side steps or running board have 12 inches rise and there are two on each step. The seats are of cherry and ash slats, they are spaced 2 ft. 8 in. between centers. The platforms are closed by leather covered chains between dasher and corner posts.

BOOKS AND PAMPHLETS.

"The Calorific Value of Fuels," founded on Kestner's "Pouvoir Calorifique des Combustibles," with the addition of a very full collection of tables of heats of combustion of fuels, solid, liquid and gaseous, by Herman Poole, F. C. S., 8vo, 40 figures, 279 pp., cloth. New York, 1898, John Wiley & Sons. London, Chapman & Hall. Price, \$3.

This book was written for the purpose of collecting all of the reliable data on the subject of fuels, because the books hitherto published in English contain only a few scattered facts regarding the calorific values, and nothing comprehensive has appeared before containing information as to how the facts were obtained, and what practical use would be made of them.

As stated in the preface, the work commenced as a translation of M. Scheurer-Kestner's "Pouvoir Calorifique des Combustibles," but changes became necessary to adapt it to American methods and data, and it was deemed advisable to use the skeleton of that work, and fill it in as considered best. Even this skeleton has hardly been preserved intact, as the arrangement of much of the material has been changed, many portions omitted, many new ones supplied, and in some of the original discussions the argument has been so changed as to point nearly opposite to that advocated by M. Scheurer-Kestner. The work embraces only that portion of calorimetric determinations having a bearing on fuel values. A concise description is given of the leading calorimeters, those most commonly used being described more fully than the others, and some examples of working and calculations are added. Coal, being the fuel most generally used, is given the greatest amount of space, but other fuels are briefly considered.

The author ties theoretical and practical work together, giving information on the methods of sampling fuel and testing it. In an appendix he reproduces the report of the committee on the revision of the code for testing boilers presented to the American Society of Mechanical Engineers at the December, 1897, meeting, and also gives a set of tables of constants used in this and allied subjects and a collection of calorimetric and analytic data on all of the kinds of fuel used. These tables are of great value, they cover coals from all parts of the world as well as gas and liquid fuels. We have not seen such a complete set of fuel tables before. This feature of the book will be specially appreciated by designing engineers. Whenever possible the author gives the source and authority for his statements, which adds to the feeling of confidence with which the work will be used.

There are twelve chapters, an appendix, a table of contents and an index. The first chapter is on the general subject of fuels, heat of combustion, thermometers and calorific values. The second gives methods of determining heat of combustion. Four chapters on calorimeters follow, with description and discussion of the processes and advantages of each. These are followed by three chapters on fuels, solid, liquid and gaseous. The next three chapters apply the calorific power of coal to boilers, and in this part of the work much that is valuable in connection with boiler testing is presented.

Engineers who design and test boilers will find the book convenient and helpful. They will probably have a large part of its contents in other forms, but not so compactly arranged. The descriptive portions are concise and yet complete. The book is up to date, and, because of the lack of good presentations of calorimetric methods, it fills a place not occupied by any previous work. The fuel tables merit further mention. They contain all the available information covering the data required that have been published to date, with analyses of fuels and the heat units as determined by the authors of the tests, whose names are given. They are arranged according to a standard plan and are comparable.

The type, paper and binding are good and the illustrations in general are satisfactory. The author's care in stating authorities is to be commended, and this is specially necessary in a subject upon which some many "doctors disagree."

"The Arithmetic of the Steam Engine," by E. Sherman Gould, M. Am. Soc. C. E.; 77 pp.; cloth; New York, D. Van Nostrand Co., 1897. Price \$1.00.

This little book was written to supply the author's own need for a collection of simple and accurate facts and rules, which he had been unable to find in any single treatise on the steam engine. He does not pretend to present anything new, but does put the accepted facts of the subject into easily accessible form

for practical use. It furnishes a clear and concise summary of the fundamental principles of the steam engine and the calculations based upon them. The author states in the preface that he believes the pages contain all that is necessary to solve the ordinary problems relating to steam in its application to the steam engine. It is a good work to have at one's elbow for the purpose of "brushing up" on the simple problems of steam-using when one has become a little "rusty." It ought to be indexed, and it ought to bear its title upon its back in order to be easily found upon the shelf. We hope that our copy was an imperfect one in these respects, and that in the rest of the edition these important points were not omitted. It has not even a table of contents. Life is too short to spend time in consulting books under such conditions; they must be read through in order to find out what they contain.

"Tops, a New American Industry; a Study in the Development of the American Worsted Manufacture." Published by The Arlington Mills, Lawrence, Mass. 130 pages, illustrated; bound in buckram, 1898.

This handsome book, published by the Arlington Mills, gives an interesting and instructive account of the American worsted industry with which this concern has been identified. It describes the introduction of a new branch of industry, or a new phase of worsted manufacture into the United States. This is the manufacture of worsted "tops," which are made for the use of spinners of worsted yarn. The buildings and equipment, as well as the materials and processes, are described and the history, development and future of the industry are presented in an interesting manner. In 1891 the Arlington Mills published a history and description of its extensive plant in a book entitled "The Arlington Mills, a Historical and Descriptive Sketch," and the present volume relates to the new buildings and processes which have developed since that time. The work is a handsome production in every respect.

"The Pneumatic Despatch Tube System of the Batcheller Pneumatic Tube Company." By B. C. Batcheller, 147 7x9½-inch pages with 50 illustrations. Philadelphia, J. B. Lippincott Company.

This book gives the only complete and definite description ever published on the subject of pneumatic tubes. It is from the pen of Mr. B. C. Batcheller, Mechanical Engineer of the Batcheller Pneumatic Tube Company. The work is divided into four chapters, the first of which is a brief historical sketch, the second an explanation of the first pneumatic tubes installed by this company for the transportation of United States mail, the third describes the system and apparatus of the company and the fourth contains facts of general information relating to pneumatic tubes and the theory and practice of their working. The book describes the system thoroughly and shows the practical applications which have been made. We are glad to have a copy in our library and every well-informed engineer will probably feel the same as we do after procuring one.

"Lubricants, Oils and Greases," by Hynd I. Redwood, 54 5½x8¼-inch pages, with three folding plates. Spon & Chamberlain. Price, \$1.50.

This is a valuable, practical book upon lubrication and lubricants. It treats the subject theoretically, and gives a great deal of information regarding the composition, uses and manufacture of lubricants, and is a good book of reference for the guidance of users of lubricants to assist in the choice of the proper article for special purposes. The author has a high opinion of grease and tells about the kinds to be avoided. Methods of testing are discussed, and his statements with regard to the manufacture of these products are valuable. The work is divided into two general divisions, "Theoretical" and "Manufacture." A number of tables and an appendix upon the action of oil on various metals are included. The style used is simple, and it is adapted to readers who are not scientifically educated.

"Practical Shop Talks." A collection of letters on shop subjects, which show by actual examples some of the existing methods of shop management and practice. By Fred H. Colvin. Press of "Locomotive Engineering," 256 Broadway, N. Y. 1,898. pp. 144. Price, 50 cents.

This little volume was written in the form of letters and appeared originally as "Notes from Notown by Ichabod Po-dunk" in the pages of "Machinery" while that publication was edited by Mr. Colvin. They present the experience and observations of a practical mechanic in a humorous and instruct-

ive way intended specially for shop men and shop managers. It is full of sensible suggestions.

"A Method of Measuring the Pressure at Any Point on a Structure, Due to Wind Blowing Against That Structure," by Prof. Francis E. Nipher. Reprinted from the Transactions of the Academy of Science of St. Louis, Mo. Vol. III., No. 1, January 14, 1898.

This is an elaborate account of a new method of measuring wind pressures and differences of pressures by means of "collectors" in the form of metal discs with wire gauze discs between them. The experiments were carried out on a car on the Illinois Central Railroad.

"Proceedings of the South African Association of Engineers and Architects." Vol. III., 1895-6-7. Received from Eden, Fisher & Company, 6 Clement's Lane, Lombard street, London, E. C.

"Statistical Abstract of the United States, 1897." Twentieth number, containing tables of population, financial, commerce, agricultural and other leading products, mining, railroads and telegraphs, immigration, education, public lands, postal service, prices, tonnage, etc. Prepared by the Bureau of Statistics under the direction of the Secretary of the Treasury, Washington, Government Printing Office, 1898.

The John Crerar Library, Third Annual Report for the year 1897, Chicago, 1898. Clement W. Andrews, Librarian.

"Illinois Steel Company," Chicago, Ill. This is an illustrated pamphlet of 42 pages, containing a description of the various works of this large manufacturing concern.

Catalogue of Mechanical Rubber Goods manufactured by the Diamond Rubber Company, Akron, O. This company has been recently reorganized with an increase in capital stock. The new president and general manager is Mr. Walter B. Hardy, who has been connected with the Revere Rubber Company of Boston for the last ten years.

Map of Cuba.—The Sargent Company of Chicago have issued a set of maps showing the West India Islands as a group, the island of Cuba and the World, showing the relative positions of the various countries. They are printed in colors and will be sent to railroad officers and users of steel castings who may apply for them.

The Rochester Automatic Lubricator Co., Rochester, N. Y., has just issued an illustrated catalogue (not standard size) describing the "Rochester Automatic Lubricator," for locomotives, marine and stationary engines, steam pumps and hydraulic elevators. The catalogue contains a number of engravings and a large number of testimonials.

"Catalogue, 1898, Institute for Home Study of Engineering." This catalogue announces the consolidation of the "Correspondence School of Technology" of Cleveland and the "Institute for Home Study of Engineering" of the same city. The schools were started in 1894, and have been very successful, and they will now throw off the character of privacy and enter the field of public institutions. Those interested in this method of education should procure the catalogue. Address Institute for Home Study of Engineering, Blackstone Building, Cleveland, Ohio.

The recently rendered decision of the United States Supreme Court in what is known as the Nebraska Maximum Rate case is ably commented upon in the "North American Review" for April by Harry Perry Robinson, editor of the "Railway Age." Mr. Robinson contends that the attempt to reduce railway rates by legislative action would be unwise in the extreme, and he enforces his argument by reference to the statistics of the earnings of the railways of the different States.

Baldwin Locomotive Works.—Record of Recent Construction, Nos. 1, 2 and 3, March, 1898. These are 32 page pamphlets with full half tone engravings and general dimensions of locomotives recently built by this firm. One is devoted to locomotives for domestic use, and the others to those for foreign service. There is no descriptive matter, but the information pertaining to the designs is sufficiently complete to permit of making selection from the designs with reference to the ordering of locomotives.

The Anti-Scalping Law.—We received too late for publication last month the full text of the recent decision of the Appellate Division of the Supreme Court of New York declaring

the Anti-Scalping law constitutional. The decision shows great care in its preparation. It is a clear statement of the law, and it will undoubtedly be used as a reference. We are indebted to Mr. Geo. H. Daniels, General Passenger Agent of the New York Central & Hudson River Railroad, for a copy of it.

Coupler Attachments.—The Thornburgh Coupler Attachments Co., Limited, of Detroit, Mich., have issued a new catalogue, designated as No. 2, in which their box followers and the Thornburgh attachments are illustrated by half tone and line engravings. The objects of the devices are to protect the springs, reduce the number of parts, increase the strength and reduce the weights of these parts and at the same time provide easy means for replacements. The half tones show the construction of the devices admirably. The pamphlet concludes with extracts from proceedings of the Master Car Builders' Association with regard to break-in-twos with the M. C. B. coupler.

"Friction and Lubrication."—The Joseph Dixon Crucible Co. of Jersey City, N. J., have sent out an eight-page pamphlet, in which the subject of lubrication of bearings is discussed and the relative merits of oil and graphite lubrication are presented. Graphite is held to be a better lubricant, theoretically and practically, and the reasons for the conclusion are stated. The pamphlet is interesting and instructive. It was prepared especially for motive power officials, and contains a suggestion with regard to the lubrication of cylinders with graphite. Several well-known authorities are quoted to show the merits of graphite from practical experiments on friction.

EQUIPMENT AND MANUFACTURING NOTES.

LOCOMOTIVES.

The Ann Arbor has bought a switching engine from the Pittsburg Locomotive Works.

H. K. Porter & Co. will build one small locomotive for the Government. It is understood that it is for use at the Brooklyn Navy Yard.

The Canadian Locomotive & Engine Company of Kingston, Ont., is building a small tank locomotive for the British Columbia, and one compound and two simple heavy 10-wheel engines for the Intercolonial.

The Schenectady Locomotive Works will build the following locomotives: One engine for the New England Gas & Coke Company, eight for the Interoceanic Railroad of Mexico, and one for the St. Joseph Stock Yards.

The Dickson Locomotive Works will build one 10-wheel engine for the Arizona & Southeastern, two 8-wheel engines for the Green Bay & Western, and six consolidation engines for the Delaware & Hudson Canal Company.

The Richmond Locomotive Works have orders for six 10-wheel locomotives for the St. Louis Southwestern, one simple and one compound mogul engine for the Brainerd & Northern, and eight consolidation engines for the Southern Railroad.

The Brooks Locomotive Works have received orders to build two 10-wheel freight engines for the Indiana & Illinois Southern, five heavy freight engines for the Chicago, Indianapolis & Louisville, two heavy 6-wheel engines for the Union Railroad, —a branch of the Pittsburg, Bessemer & Lake Erie,—two consolidation engines for the Colorado & Northwestern, one 10-wheel freight engine for the St. Louis, Indianapolis & Eastern, five 10-wheel simple freight locomotives for the Toledo & Ohio Central.

The Baldwin Locomotive Works have received the following orders: One engine for the Sparta Iron Company, one for the Mahoning Ore Company, one for the Sorocabua & Ituana Railroad, sixteen freight locomotives for the Canada Atlantic, two for the Argentine Government Railroads, one American type locomotive for P. G. Mendez & Co. of Mexico, five mogul engines for the Egyptian Government Railways, five compound consolidation freight engines for the Ottawa Arnprior & Parry

Sound Railroad, six consolidation engines for the Roblaa Val-maseda Railroad of Spain, twelve Vaucrain compound, six coupled tank locomotives, with pony trucks, for the Chinese Eastern Railroad (the Russian railroad across Manchuria), ten 10-wheel freight locomotives, four Atlantic type passenger locomotives for the Lehigh Valley, one consolidation locomotive for the Surrey, Sussex & Southampton, six two-cylinder compound freight engines for the Norfolk & Western, four consolidation engines for the Western Maryland Railroad, nine 10-wheel compound engines for the Philadelphia & Reading, one narrow gauge six-wheel mining locomotive for the Southwest Virginia Improvement Company, one shifting engine for the Standard Steel Works, one small four-wheel engine for the Ashland Coal & Coke Company, and four consolidation locomotives for the Southern Railroad.

CARS.

The Illinois Car & Equipment Co. will build 250 gondola cars for the Louisville & Nashville.

The Ensign Manufacturing Co. have orders for 200 coal cars for the Toledo & Ohio Central.

The Elliott Car Co. have received an order for 200 box cars for the New Orleans & Northeastern.

The Wason Manufacturing Co. will build four passenger cars for the Central Railroad of Brazil.

McCorð journal boxes were specified for 800 cars recently ordered by the Toledo & Ohio Central.

The Union Car Co. will build 1,000 of its standard 60,000 lbs. capacity box cars for the Lehigh Valley.

The Terre Haute Car & Manufacturing Co. will build two cars for the Heatherington & Burme Railroad.

The Ohio Falls Car Mfg. Co. are building 200 freight cars and 3 postal cars for the Nashville, Chattanooga & St. Louis.

The Wells & French Co. will build 400 cars for the Toledo & Ohio Central, and three freight cars for the Fairchild & Northeastern Railroad.

The Pullman Palace Car Co. have orders to build 750 hopper bottom gondola and 250 flat bottom gondola cars for the Chesapeake & Ohio.

The Jackson & Sharp Co. are building two passenger cars for the Baltimore, Chesapeake & Atlantic, and 250 cars for the Argentine Government.

Schoen's steel truck bolsters and Bettendorf brake beams will be used on 200 stock cars to be built by the Chicago, Rock Island & Pacific in its Chicago and Houston shops.

The Barney-Smith Car Co. are building the following cars: Four passenger for the Wabash Paper Co., 100 cars for the Southern Pacific, 8 new motor cars for the Metropolitan West Side Elevated of Chicago.

The St. Charles Car Co. is building one passenger car for the Kansas City, Fort Scott & Memphis, 21 cars for the Missouri Pacific, 2 passenger and 10 freight cars for the Louisiana & Northwest Railroad.

The Michigan-Peninsular Car Co. have received the following orders: 200 coal cars for the Toledo & Ohio Central, 200 refrigerator, 1,000 box and 1,000 twin hopper coal cars for the Erie Railroad.

The following roads are building cars at their own shops: The Grand Trunk 200 coal cars, the Mexican National 100 box cars, the Minneapolis & St. Louis 25 stock cars, and the Canadian Pacific 300 flat and 500 box cars.

The Missouri Car & Foundry Co. are building 4 more cars for the Wells, Fargo & Co. We referred to an order for 50 for this same company in our March issue. This firm is also building 400 box cars and 100 coal cars for the Texas Pacific, 1,500 box and 500 stock cars for the Union Pacific, 12 freight cars for the Oahu Railroad & Land Co. of Hawaii, 100 furniture cars for the Louisville & Nashville.

During the past two months the Baltimore & Ohio Railroad Company has received 1,110 new box cars, 1,239 double hopper gondolas and 224 coke cars of the orders for 5,150 cars recently placed with Pullman's Palace Car Company, the Michigan Peninsular Car Works, the Missouri Car and Foundry Company and the South Baltimore Car Works. Deliveries are being made as rapidly as the cars are completed.

The Schoen Pressed Steel Co. have an order for 1,000 steel cars of 110,000 lbs. capacity for the Pennsylvania Railroad. The contract is about \$1,000,000, and is the largest contract ever given for steel cars, and it points to the probability that steel cars will come into use very rapidly, owing to the endorsement by this road. These cars will be 10 feet high from the top of the rail, and will carry 110,000 lbs. of ore and 104,000 lbs. of coal. They will weigh 37,000 lbs. each and will have 5½ by 10 inch journals. The same builders are at work on an order for 200 more cars of the same size for the Pennsylvania west of Pittsburg. The order is to be completed by Oct. 1.

MISCELLANEOUS.

The Western agency of the Pennsylvania Steel Co. has been taken by the Q & C Co., Western Union Building, Chicago.

The new underground railway of London has decided to use the Westinghouse Air Brake.

The plant of the Schoen Pressed Steel Co. is to be enlarged to such an extent as to increase the present capacity of 20 cars per day up to 50 per day.

Six Patton combination gasoline and electric motor cars are now building at the Siemens & Halske Works in Chicago. They are to be used in suburban service at Chattanooga, Tenn.

An Australian rail contract amounting to 14,030 tons has been taken by the Pennsylvania Steel Company in competition with two English, one German and one other American firm. The price of the accepted bid was \$19,000 less than the English bids.

The Edward P. Allis Company of Milwaukee, Wis., has delivered to the Carnegie Steel Company, Ltd., at Pittsburg, for their Duquesne Steel Works, a large Bessemer blowing engine. The shipping weight of this engine will be about 500,000 pounds.

Work on government contracts has led to a number of good orders for hydraulic machinery placed with Messrs. Watson & Stillman, including several large forging presses for the navy department, and powder presses for the manufacture of smokeless powder.

The electric lines of the New York, New Haven & Hartford are to be extended and the rail between East Weymouth and Braintree are now being changed from 56 pound to 100 pound section. This addition will bring the total line operated by electricity to 15 miles in length. The electric trains at Braintree are to be turned on a loop in order to facilitate traffic.

The Westinghouse Electric and Manufacturing Company has just opened a new branch office at Austin, Tex. Mr. J. E. Johnson will have charge of the office and of the further extension of Westinghouse business in the Southwest. The large contracts which this company has been handling in Mexico and the Texas region have led to the establishment of this new center of electrical trade.

The electric railways projected in Japan are three in number. Consul Lyon, writing from Kobe, says that one is to be 15 miles in length, extending from Kobe to Amagasaki. The company has a capital of \$249,000, and the work is to be completed within two years. The time for beginning the work is not fixed. Another line is to be between Amagasaki and Osaka—5 miles. The company is to have a capital of \$149,900. The charter has not yet been granted. The promoters of these two roads are Mr. Shinyemon Konishi, of Itamicho, Kawabe-gun, Japan; Mr. Ki-ichiro Kosone, of Minato-cho, Kobe-shi, Japan, and twenty-eight others. Another road is projected to run from Kobe to Armina, 15 miles. The capital is \$149,000. The date for commencing the work is not fixed. The promoters are Mr. Ki-ichiro

Naka, of Arino-mura, Arima-gun, Japan; Mr. Shigezo Yamamoto, of Fukiai-mura, Kobe-shi, Japan, and eighteen others.

Japan apparently favors American iron and steel. The New York Commercial prints an interview with Mr. L. C. Brittain, of London, touching this, in which he said: "For example, during my recent sojourn in Tokio I happened to hear of an opportunity to place a large order of iron and steel products. I am interested in the iron business, and I decided to make a bid. Imagine my surprise when I was politely informed that it would be impossible to consider any other offers than those made by American firms. I asked the reason for this, and was told that in the opinion of experts of Japan, the United States furnished the best article to be found in the markets of the world. I intend to make it my business when I return home to have at least one iron and steel company in Great Britain properly represented in the leading cities of Japan and China. If need be, we will hire Americans to do the work, for apparently they are the best for drumming up trade."

The rapid movement of the Government Reindeer Special over the Pennsylvania, the Chicago, Milwaukee & St. Paul and the Great Northern Railroads was noted last month. Mr. G. D. Meiklejohn, Assistant Secretary of War, wrote the following letter to Mr. J. B. Thayer, Jr., General Freight Agent of the Pennsylvania, dated Washington, D. C., March 15, 1898: "I take this opportunity to thank you on behalf of the War Department for the very prompt, efficient and entirely satisfactory service rendered by your road, in connection with the Chicago, Milwaukee and St. Paul and Great Northern Railways, in transporting the Government reindeer expedition and attendants across the continent. The arrangements, so complete in every detail, provided for the safety and comfort of the expedition, enabled the trip to be made without inconvenience, sickness, or serious mishap of any kind, and the entire expedition arrived at the western terminus in the best of condition. The time made by your road surpassed all expectations, and the success of the shipment was very gratifying to the Department."

Our Directory

OF OFFICIAL CHANGES IN APRIL.

Atlantic and North Carolina.—Mr. David W. Patrick has been appointed President, succeeding Mr. Robert Hancock.

Atchison, Topeka & Santa Fe Pacific.—Mr. George W. Smith, heretofore Master Mechanic of the Eastern Division of the A., T. & S. F., with headquarters in Topeka, Kan., has been appointed Superintendent of Machinery, with headquarters at Albuquerque, N. M.

Canada Atlantic.—Mr. M. Donaldson has been appointed General Superintendent; he was formerly Superintendent.

Canadian Pacific.—Mr. J. W. Harkom has been appointed Assistant Mechanical Superintendent; he was formerly Master Mechanic of the Eastern Division of the Grand Trunk.

Central of New Jersey.—Mr. W. L. Hoffecker has been appointed Master Mechanic in charge of New Jersey Central division. Mr. J. G. Thomas is appointed division Master Mechanic in charge of Lehigh & Susquehanna Division. Mr. J. H. Thompson has been appointed Chief Engineer, with headquarters at Jersey City, N. J., and the office of Engineer of Construction, formerly held by him, has been abolished.

Central Pacific.—Mr. William Thompson of San Francisco, has been elected a Director, succeeding Mr. I. E. Gates of New York, and Mr. William H. Mills, heretofore Second Vice-President and Treasurer, was elected Vice-President and Treasurer. Mr. J. C. Kirkpatrick was elected Second Vice-President and Mr. Charles P. Eels was elected Third Vice-President.

Chicago Great Western.—Mr. Raymond Du Puy has been appointed General Superintendent, with headquarters at St. Paul, Minn., to succeed Mr. Cornelius Shields, resigned.

Chicago & Northwestern.—Mr. Frank Slater has been appointed Master Mechanic, with office at Escanaba, Mich., vice Mr. J. W. Clark, resigned.

Chicago, Milwaukee & St. Paul.—Mr. H. R. Williams has been appointed General Superintendent, with headquarters at Chicago, succeeding Mr. W. G. Collins, promoted to the position of General Manager and relieving Mr. A. J. Earling of the duties of that office.

Chicago & South Eastern.—Mr. W. C. Halfman has been appointed Master Mechanic, with headquarters at Lebanon, Ind., to succeed Mr. J. W. Roberts.

Chicago, Rock Island & Pacific.—Mr. J. Van Dell has been appointed Master Car Builder, in charge of the Chicago shops, to succeed Mr. L. T. Canfield, resigned.

Cleveland, Cincinnati, Chicago & St. Louis.—Mr. George

Tozzer has been appointed Purchasing Agent; he was formerly Assistant Purchasing Agent, with office at Cincinnati, succeeding the late Mr. A. M. Stinson.

Detroit, Toledo & Milwaukee.—Mr. J. R. Megrue has resigned as Vice-President and General Manager, and Mr. N. K. Elliot will have charge of the operation and maintenance of the property with the title of Superintendent. Mr. J. W. Witmer has resigned as Master Mechanic, and Mr. L. M. Studevant has been appointed Purchasing Agent.

Detroit & Lima Northern.—Mr. J. W. Witmer, Master Mechanic of this road, formerly at Marshall, Mich., will hereafter make his headquarters at Tecumseh, Mich.

Delaware, Lackawanna & Western.—Mr. W. F. Hallstead is now Second Vice-President as well as General Manager.

Florida East Coast.—Mr. R. W. Parsons has been appointed Second Vice-President, with headquarters at 26 Broadway, New York.

Galveston, Houston & Henderson.—Mr. Leroy Trice has been elected Vice-President, succeeding Mr. John M. Duncan.

Gulf, Beaumont & Kansas City.—Mr. J. F. Weed has been appointed Chief Engineer, with headquarters at Beaumont, Tex.

Grand Trunk.—Mr. J. W. Harkom has resigned as Master Mechanic of the Eastern Division, with office at Montreal, and has been succeeded by Mr. Thomas McHattie as Acting Master Mechanic.

International & Great Northern.—Mr. Leroy Trice, the General Superintendent of this road, has also been elected a Director.

Knoxville & Bristol.—Mr. J. V. Woodward of Philadelphia has been elected President, succeeding Mr. Adolph Segal.

Lake Erie & Detroit River.—Mr. Joseph De Gurse, Chief Engineer, died at Winsor, Ont., March 22, at the age of 41 years.

Lake Shore & Michigan Southern.—Mr. W. H. Newman, Second Vice-President of the Great Northern, has been selected to succeed Mr. S. R. Callaway as President.

Missouri, Kansas & Texas.—Mr. Colgate Hoyt has been elected Vice-President, succeeding Mr. William Dowd.

Mobile & Birmingham.—Mr. J. J. Thomas, heretofore Master Mechanic, with office at Mobile, Ala., has resigned to go to the Mobile & Ohio.

Morgan's Louisiana & Texas.—Mr. J. G. Schriever, Vice-President, died at New York recently, at the age of 54.

New York Central & Hudson River.—Mr. Chauncey M. Depew has resigned as President, to take the Chairmanship of the Board of Directors of the Vanderbilt lines. He has been succeeded by Mr. L. R. Callaway, formerly President of the Lake Shore. Mr. H. Walter Webb has resigned as Third Vice-President.

New York, Chicago & St. Louis.—Mr. Theo. H. Curtis, formerly Chief Draftsman, has been given the title of Mechanical Engineer.

Oregon Short Line.—Mr. D. J. Malone has been appointed Master Mechanic of the Idaho and Montana Divisions, with headquarters at Pocatello. Mr. W. J. Tollerton has been appointed Master Mechanic of the Utah Division, with headquarters at Salt Lake City, Utah.

Pennsylvania.—Mr. W. F. Beardsley, Master Mechanic of the shops of the Pennsylvania lines at Allegheny, Pa., has had his jurisdiction extended over the Erie & Ashtabula Division, effective April 1, and Mr. T. A. Kircher has been appointed Assistant Master Mechanic at the Allegheny shops.

Plant System.—Mr. J. G. Justice, formerly General Foreman at Waycross, Ga., has been appointed Master Mechanic at Savannah, Ga., succeeding Mr. D. B. Overton, resigned. Mr. S. M. Roberts has been appointed General Foreman at Waycross, succeeding Mr. Justice.

Rockport, Langdon & Northern.—Mr. John P. Lewis has been elected President, succeeding Mr. John Lockwood. His office will be at Rockport, Me.

Salt Lake & Ogden.—Mr. James M. Kirk has been appointed Master Mechanic, with headquarters at Salt Lake City, Utah, to succeed Mr. W. T. Godfrey, resigned.

Sherman, Shreveport & Southern.—Mr. W. A. Williams has been elected Vice-President, succeeding Mr. Thomas H. King.

Southern Pacific.—Mr. J. Kruttschnitt has been elected Fourth Vice-President; he is also General Manager.

St. Louis & San Francisco.—Mr. C. H. Beggs has been appointed Purchasing Agent, he is also Secretary to Vice-President and General Manager, with office at St. Louis.

St. Louis & Kansas City.—Mr. J. W. Sherwood has been appointed General Superintendent, with headquarters at Toledo, Ohio, vice Mr. A. L. Mills, resigned.

Terre Haute & Indianapolis.—Mr. George W. Prescott, formerly Superintendent of Motive Power, has been appointed Foreman of the shops of that road at Logansport, Ind., to take effect April 1.

Texas Central.—Mr. Charles Hamilton has been elected Vice-President and General Manager, with office at Waco, Tex., and Mr. Richard Oliver has been elected Secretary and Treasurer.

Washington & Columbia River.—The positions of Assistant General Manager and Superintendent of Motive Power, which were held by Mr. F. Rogers and Mr. J. M. Winslow, have been abolished.

AMERICAN ENGINEER CAR BUILDER AND RAILROAD JOURNAL.

JUNE, 1898.

CONTENTS.

ILLUSTRATED ARTICLES: Page Two Cylinder Compound Locomotives, N. & W. Ry. 181 60,000 lb Coal Cars—L., S. & M. S. Ry. 181 10-Wheel Locomotives, Wisconsin Central Lines. 192 The Horse Power of Locomotives 194 Horwich Shops, Lancashire & Yorkshire Ry. 194 Locomotive Characteristics. 196 Locomotive Design, Driving Axles. 202 Winans' Camel Engines. 205 Crank Pin and Axle Calculations 211 Restaurant and Dining Cars, Intercolonial Ry. 211 MISCELLANEOUS ARTICLES: The Air Resistance of Trains. 186 The Construction of a Modern Locomotive. 187 MISCELLANEOUS ARTICLES: Page Heating Feed Water with Live Steam 197 More Light on the Compound Locomotive 210 Success of Railroad Men in Other Fields of Labor. 210 Fast Train—Siberian Railroad. 210 Ton Mile and Engine Mile in Locomotive Statistics 211 Chemistry Applied to Railroads. 214 Reconstructing Locomotives. 216 EDITORIALS: Wrong Repairs. 198 Height of Couplers. 198 Advantages of Large Boilers. 198 Locomotive Truck Brakes. 198 Competitive Tests of Locomotives. 198 The Breaking in Two of Freight Trains. 201 Premiums for Conscientious Efforts 201

receiver into the low-pressure cylinder, the reduced receiver pressure controls the reducing valve, closing it or opening it to allow the proper wire drawing of high-pressure steam to fill the receiver, which pressure is supposed to be about 85 pounds, the safety valve on the receiver, immediately ahead of the smoke stack, being set to 90 pounds. Under these conditions the engine will run as a simple engine, reducing the steam from the boiler to suit the increased size of the low-pressure cylinder, the cab valve being maintained in the position marked simple.

When desiring to compound the engine, the cab valve is turned to the compound position. This admits steam from the boiler into the pipe running to the intercepting valve, pushing it ahead, thus cutting off the opening to the exhaust pipe, and compelling steam from the high-pressure exhaust port to pass into the receiver. At the same time steam passes to the reducing valve, closing the reducing equalizer valve by means of the packing rings and pressure on top of the valve, and opens the reducing check valve, thus admitting full steam pressure on the large portion of the reducing valve, which by this excess pressure is closed, thereby preventing the ad-

DATA ACCOMPANYING INDICATOR CARDS.

Table with columns: Card number, Per cent. grade, Speed, Throttle opening, Reverse lever, Simple or compound, Boiler pressure, Steam line H. P. cylinder, H. P. cylinder, L. P. cylinder, Indicated tractive power (H. P. cylinder, L. P. cylinder, Total), Per cent. of work in H. P. cylinder.

BALDWIN TWO CYLINDER COMPOUND LOCOMOTIVES—NORFOLK AND WESTERN RAILWAY. With an Inset.

The Baldwin Locomotive Works recently built six heavy, two cylinder compound consolidation locomotives for the Norfolk and Western Railway, from designs worked up conjointly by the builders and the railway company. These engines have a number of new features, which are interesting to students in locomotive design. They are known as "Class B." The most interesting feature of the design is the compounding arrangement, which can be easily understood by reference to the drawings showing the details of the cylinders, and the operation of the intercepting and reducing valves. The dimensions of the engine are shown in Fig. 2. To us this appears to be the handsomest heavy engine that we have seen.

Steam is admitted from the throttle directly to the high-pressure steam chest, passing through the saddle of the high-pressure cylinder and around the intercepting valve, which, with the reducing valve, is located in the saddle of the high-pressure cylinder, these cylinders being also provided with an independent exhaust pipe as in simple engines. The low-pressure cylinder is substantially like an ordinary simple engine, except that it receives its steam from an intermediate receiver, located in the smoke box instead of from the T head, and it also has an independent exhaust pipe. One general distinction between this two-cylinder compound and those in general use, consists in the fact that the operation of the engine as a single expansion or compound locomotive is not governed automatically, but is entirely under the control of the engineman, so that it can be operated either way as desired by simply turning the handle of a valve in the cab. When the cab valve is in the position for simple working, upon the opening of the throttle the valves assume the position shown in Fig. 3. Under these circumstances, steam from the exhaust of the high-pressure cylinder passes through the intercepting valve and directly to the high-pressure exhaust pipe, precisely as in a simple engine. Steam also passes through the opening of the reducing valve into the intermediate receiver, and lifts the reducing equalizing valve, establishing communication between the receiver and the large end of the reducing valve. The reducing check valve is kept shut by the receiver pressure being upon it. The two ends of the reducing valve have proportions the same as the high and low pressure cylinders, and as the steam passes from the

mission of steam direct to the intermediate receiver, the reducing equalized valve, in this case, shutting off the connection between the large portion of reducing valve and the intermediate receiver.

When, for any purpose, it is desired to change the engine back to simple, the cab valve is turned to that position, thus exhausting the steam out of the pipe to the cylinder, whence the intercepting valve will return to its first position, being impelled by the spring and also the receiver pressure acting against the piston on the front end. The exhausting of the steam from the small pipe, by means of the cab valve, is followed by the closing of the reducing check valve, and by the opening of the reducing equalizer valve by the excess pressure on the under side, thus establishing communication with the receiver, and allowing the reducing valve to open, admitting the proper supply of steam from the direct steam passage in the high pressure cylinder saddle.

If a particularly difficult portion of track requires simple

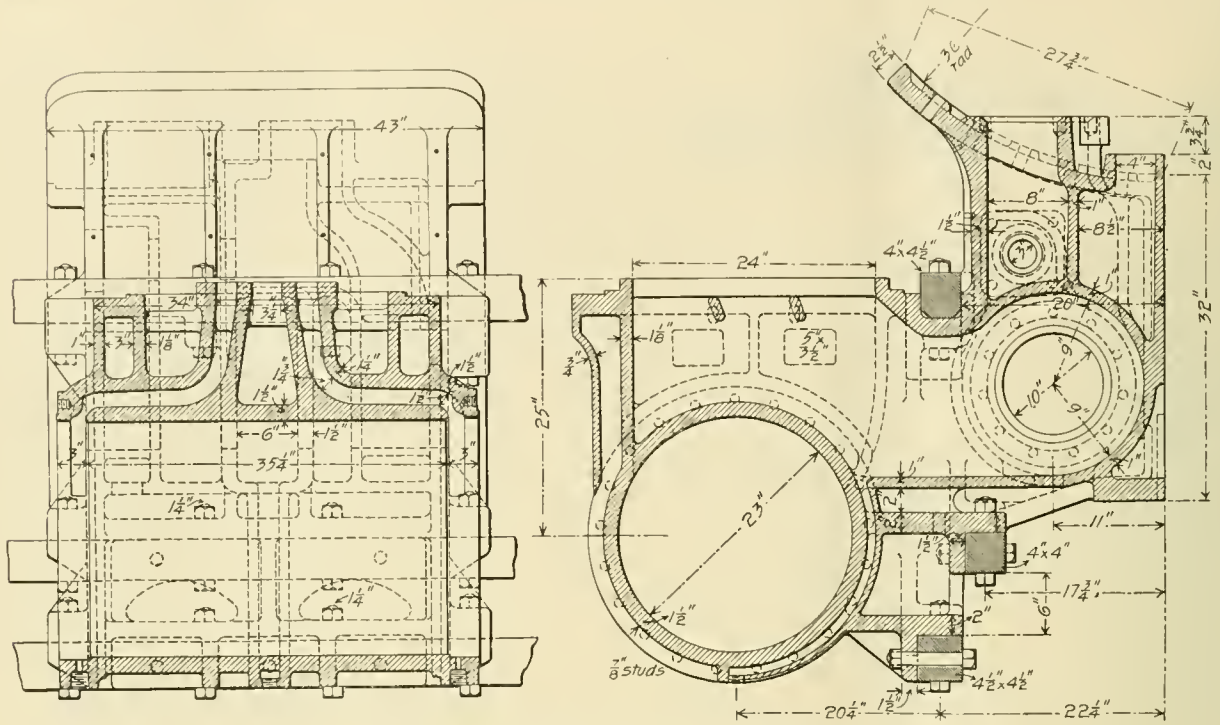

Fig. 5.—Sections of High Pressure Cylinder.

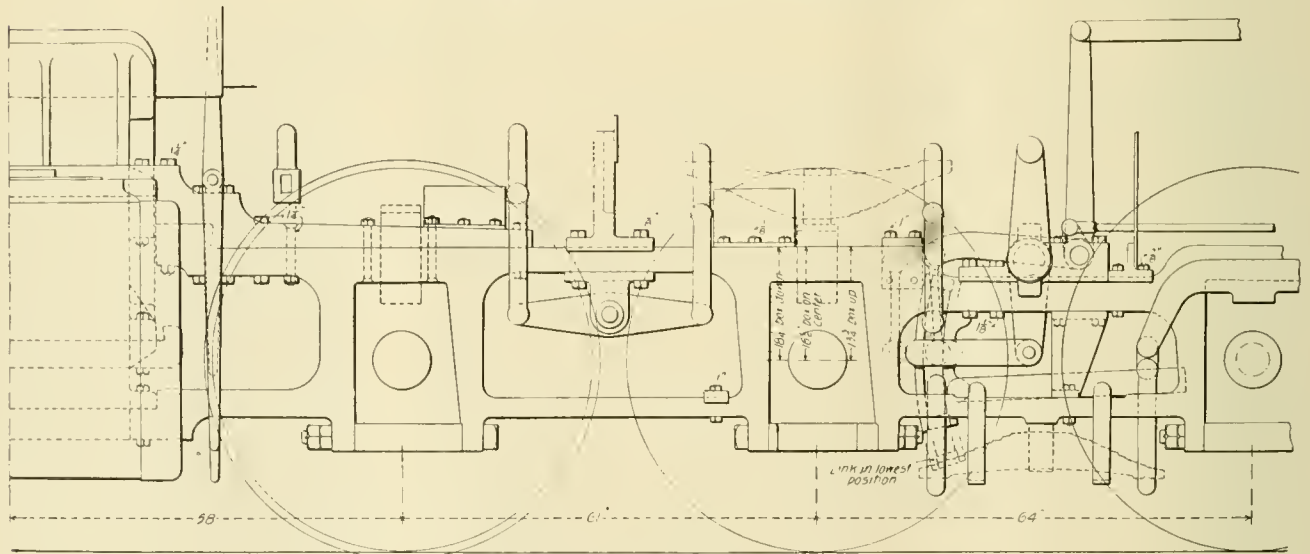

Fig. 7.—Frames and Valve Motion.

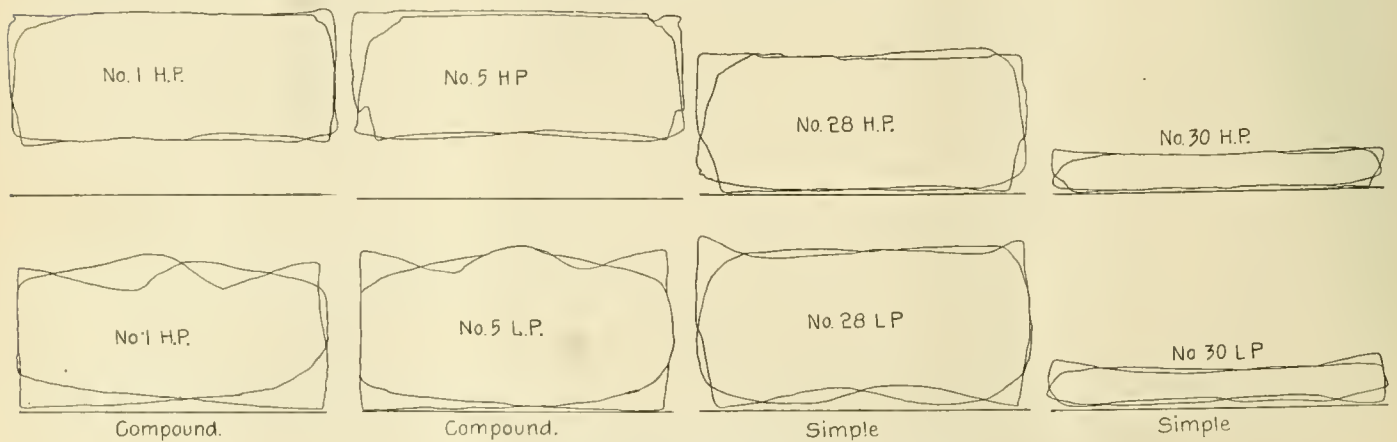

Fig. 8.—Selections from Indicator Cards—Half Size.

BALDWIN TWO CYLINDER COMPOUND LOCOMOTIVES—NORFOLK & WESTERN RAILWAY.

W. H. LEWIS, *Superintendent Motive Power.*

G. R. HENDERSON, *Mechanical Engineer.*

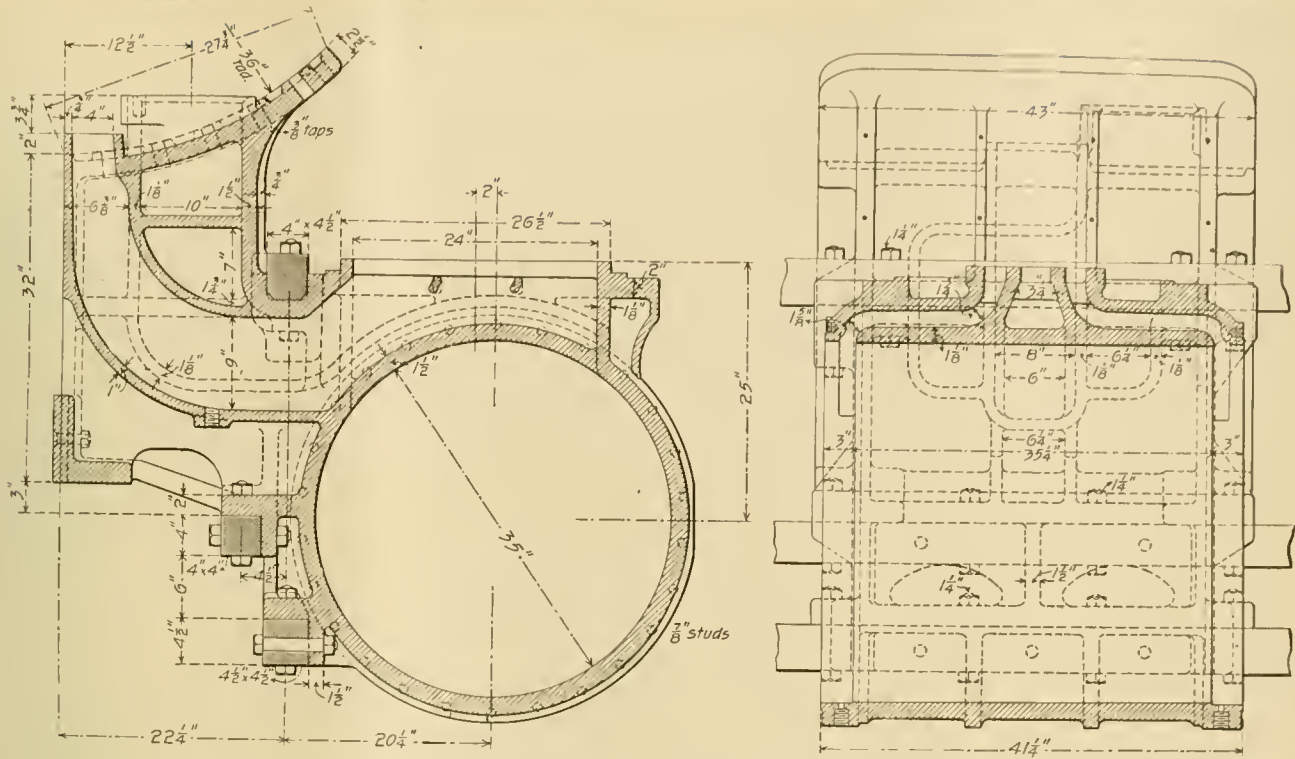

Fig. 6.—Sections of Low Pressure Cylinder.

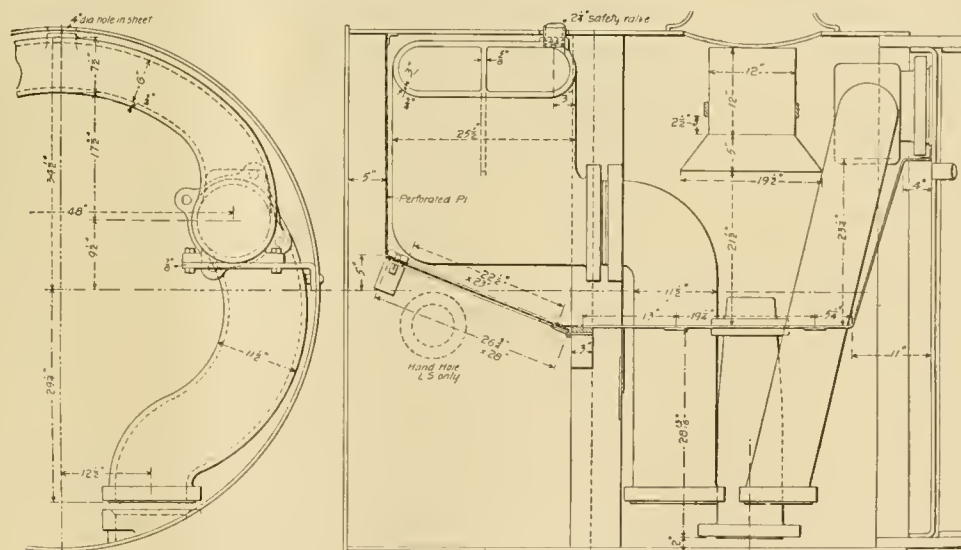

Fig. 9.—Receiver and Front End.

working, the steam from the cab valve is exhausted, where-upon the excess pressure on the underside of the reducing equalizing valve immediately lifts it so that live steam can again pass to the receiver, the intercepting valve having in the meantime gone to its original position, by the assistance of the spring in the front head, and also by the receiver pressure acting against the front end of the valve. The practical results of this arrangement can be seen by inspecting the indicator diagrams, which were taken from one of the engines while in its regular work on the mountain divisions of the Norfolk and Western Railway, and the tabulated data given shows the relative amount of work done by the two cylinders from which it will be seen that quite a close equalization has been obtained, and it will also be noticed that the indicated tractive power is very high.

In connection with the cylinders, the arrangement of frames is original. The upper bar of the main frame butts against, and stops at the back face of the cylinder, while the lower bar of this frame extends as far as the front end of the cylinder,

having a lug forged on the end in order to wedge the cylinder tight. The top front end frame is spliced to the main frame with a long extension, and passes over the top of the cylinder, extending to the bumper. The bottom front end frame has no connection with the main frame, but is secured independently to the cylinders, extending from the bumper to the back cylinder face, to which it is wedged. This results in making the lower front end frame practically a straight bar from the cylinder to the bumper, and avoiding the curve or goose neck, which is often necessary in order to clear the truck. This arrangement necessitates more novelties in the detail design of the cylinder and the arrangement of ribs or arches connecting the lugs to which the frames are bolted, evidently giving great resistance to the casting at this point.

The arrangement of the receiver in the smoke box is new, and deserves particular mention, as by this means any part of the receiver can be taken down without disturbing the other connections, and it also leaves plenty of room for the inspection of the smoke box and netting. The link motion

has been so arranged that the use of hooked or bent eccentric hods has been avoided and a link of comparatively long radius introduced. The link die pin passes through a bar, which is supported at one end by the lower end of the rocker arm, and at the other end by a link having the same length as the lower rocker arm. In this arrangement the motion of the block is exactly the same as if it were secured directly to the rocker, and as it is attached between the supports of the carry bar instead of overhanging at one end, the rigidity of the parts will be much improved.

The cab is made of sheet steel, lined with wood, and is very roomy and comfortable. The crank pins and main driving axles were made of 3½ per cent. nickel steel, and the main wheel centers were of cast steel; the others being cast iron. The first, second and fourth driving axles were of hammered iron; the object of this special arrangement being to give the greatest strength where needed at the main axle, and not to increase the cost unnecessarily of the other axles that seldom give trouble by breaking. The engines are fitted with the Westinghouse and American equalized driver brake, with the double Leach sanding apparatus and magnesia sectional lagging.

It should be added that the various features relating to the compound device are covered by existing patents, or by others which have been applied for and not yet granted. The following table is given for the purpose of comparison with other designs:

Gauge	4 ft. 9 in.
Diam. driving wheels	.56 in.
Wheel centers, main	cast steel
" " 1st, 2d and 4th.	cast iron
Tires	Latrobe steel
Right wheel base	24 ft. 6 in.
Rigid wheel base	15 ft. 6 in.
Diam. driving axle bearing	8½ in.
Length	10½ in.
Main driving axle	nickel steel
Other	hammered iron
Diam. main crank pin bearing	6½ in.
Length	7 in.
Diam. main side rod bearing	.5 in.
Length	.6 in.
Diam. intermediate	.5 in.
Length	.5 in.
Diam. 1st, 2d and 4th side rod bearing	.5 in.
Length	.3½ in.
Crank pins	nickel steel
Diam. truck wheels	30 in.
Truck wheels	cast iron, steel tired
Diam. truck axle bearing	6 in.
Length	10 in.
Truck axle	hammered iron
Diam. high pressure cylinder	23 in.
" " low	35 in.
Length of stroke	32 in.
Spread of cylinders	85 in.
Type of valve gear	shifting link
Travel of valve	5¾ in.
Lap of valve	1 in.
Lead	1-16 in.
Length of steam ports	24 in.
Width	2½ in.
" " exhaust	3 in.
Center to center of frames	44½ in.
Minimum external diam. of boiler	68 in.
Maximum	77¼ in.
Type of boiler	extended wagon top
Top of rail to center boiler	8 ft. 6 in.
Number of tubes	306
Outside diam. of tubes	2¼ in.
Length between tube sheets	14 ft. 5 in.
Heating surface of tubes	2,598.5 sq. ft.
" " fire box	197.5 sq. ft.
" " total	2,796 sq. ft.
Length of fire box	10 ft. 1 in.
Width	3 ft. 5½ in.
Height	6 ft. 2 in.
Grate area	35 sq. ft.
Minimum diam. of taper smoke stack	15 in.
Top of stack from top of rail	15 ft. 3 in.
Width of cab	12 ft. 4 in.
Exhaust nozzle, single	5¼ in.
Boiler pressure	200 lbs.
Weight of engine, empty	161,000 lbs.
" " working order	185,700 lbs.
" " on drivers	165,600 lbs.
" " truck	20,100 lbs.
Brakes	Westinghouse and American
Leach sanding apparatus, double	
Magnesia sectional lagging	
Capacity of tank	4,000 gals.
Capacity for coal	17,000 lbs.
Diam. tender wheels	33 in.
Material	cast iron
Diam. tender truck journals	4¼ in.
Length	8 in.
Weight of tender, empty	34,700 lbs.
" " full	84,700 lbs.

NEW 60,000-POUND COAL CARS—LAKE SHORE & MICHIGAN SOUTHERN RAILWAY.

This design is for special service in the coal and ore trade from Lake Erie ports and for use with the McMyler unloading machine. In this machine the car is tipped endwise at an angle of about 45 degrees and a lifting end gate allows the coal to slide through the open end, over an apron and directly into the hold of the vessel. This admits of no projections that would interfere with the easy sliding of the coal, either to crush it or form pockets that would hold it. In this service the cars are loaded to their full capacity and often to the full amount of excess weight allowed. Although of a marked capacity of 60,000 lbs., the box is sufficiently large to hold 66,000 lbs. of coal, and the construction throughout is designed to carry this load in regular service. The body of the car is known as Class F-6 and the truck Class L-6.

The general dimensions of the car are as follows. Five hundred of these cars have just been built by the Buffalo Car Manufacturing Co.:

	Ft.	In.
Length over end sills	34	..
Length inside box	31	5½
Width over side sills	8	9
Width inside box	8	3
Height to top of box	8	6¾
Height over brake shaft	9	6¼
Height of box inside	4	5¾
Length of drop opening	2	4
Width " " "	1	10

There are eight longitudinal sills of long leaf yellow pine. The side sills are 4½x12 in., with 4-in. lips under the end sills. The center and intermediates are 4½x8 in., spaced 8 in. apart, the outside intermediates being spaced 10¼ in. from the side sills. The end sills are of 8x8 in. white oak, extending 3 in. beyond the faces of the side sills. The drop door sills are of 4½x8 in. white oak, framed between the center and outside intermediates. The cross tie timbers are of 4½x12 in. white oak, spaced 6 ft. 6 in. apart.

The body bolsters, located 5 ft. from each end, are formed of three members, the upper one, ¾x8 in., in sections, being on top of the floor timbers and lipping under the side sills. The ends of the bottom member, which is 7/8x8 in., in section, are turned up and butt against the top member, while a malleable casting secured with bolts firmly unites the ends and forms a truss rod saddle. The center member forms a support for part of the floor timbers, and combined with the central part of the bottom member forms a separate truss. A malleable distance piece secures the members at the center. The side bearings are of cast iron and the center plates of pressed steel. There are four 1½ in. body truss rods with cast iron bearings 10¾ in. deep bolted to the cross-tie timbers. The sub floor timbers are of 5x5 in. yellow pine, extending from the draft rod cross timbers to the centers of the body bolsters. Similar pieces are fitted between the cross-tie timbers and from the cross-tie timbers to the draft rod cross timbers.

In the floor near the center of the car are four drop doors for unloading through the floor when desired. The surface of these doors is flush with the top of the floor so that no pocket is formed to catch coal when in the unloading machine. The locking mechanism for these doors follows the principle of an ordinary doorlatch, except that the spring latch is on the sills instead of the door. The doors are closed by a chain winding on a drum. When closed the latch automatically locks the door, and the arrangement is such that the door cannot be left nearly closed supported by the chain. The sides of the box are formed of 3 in. plank supported by 9 strong stakes in malleable iron stake pockets. Two stakes on each side are longer and lip over the ends of the cross-tie timbers. At the ends the sides are held in position at the top by an oak strut and a tie rod. Several years' experience, with this form of construction and size of material, shows that the sides are sufficiently strong to withstand the load without spreading.

The end doors lift to permit the load to dump, as already mentioned. The brake shafts are put at the corners to be out of the way. The end doors are of 5 planks 3x10½ in., stiff-

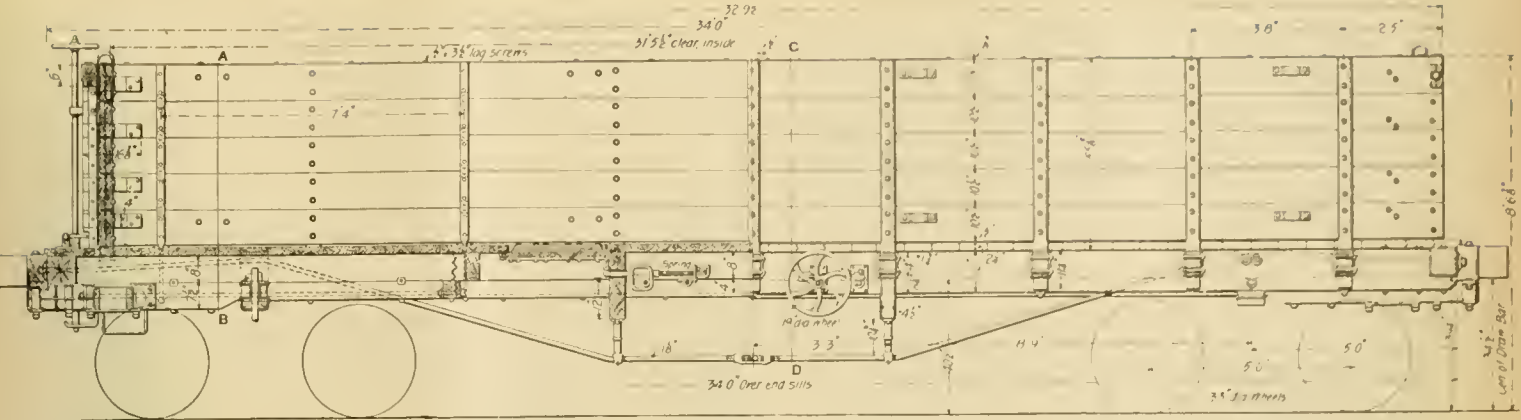

Longitudinal Sections of Car.

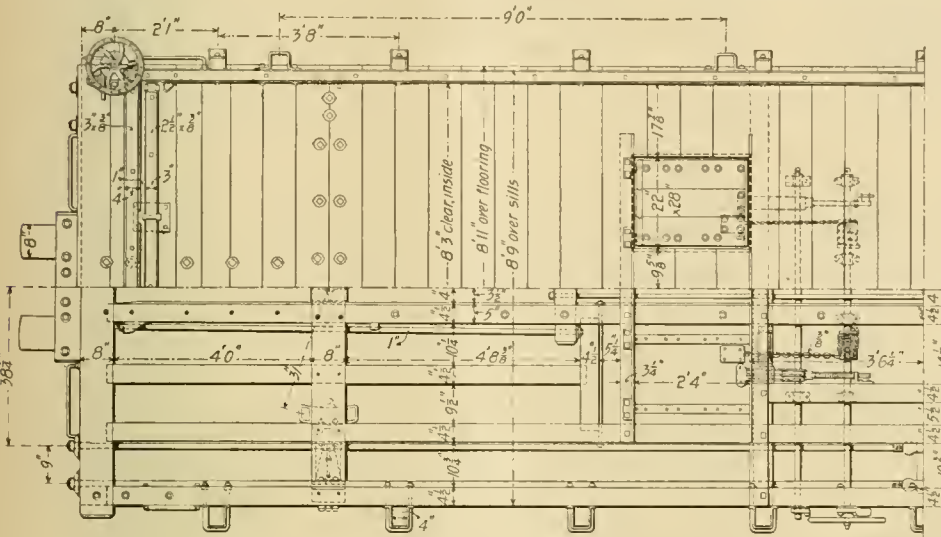

Underframe, Doors and Floor.

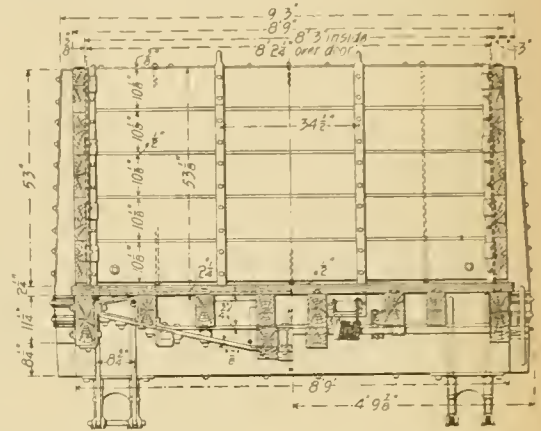

Section A-B.

Section C-D.

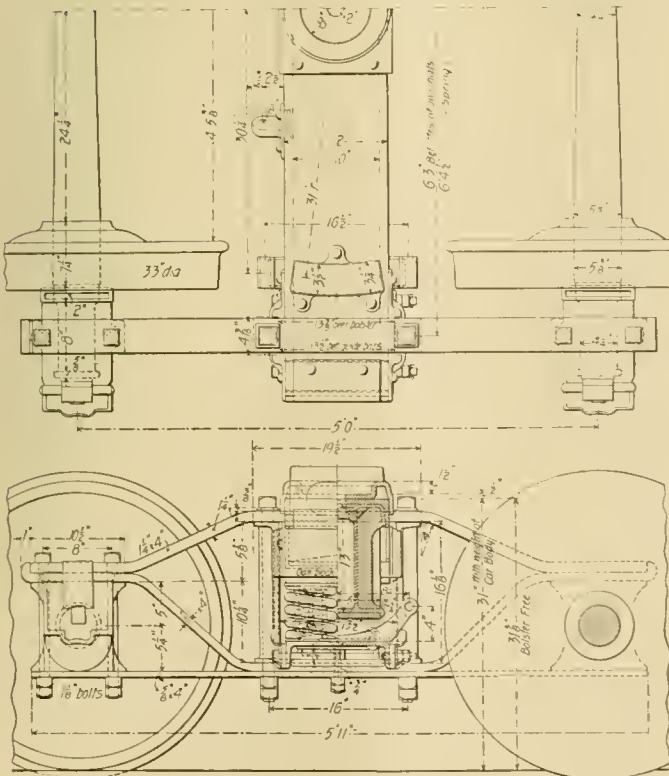

Trucks.

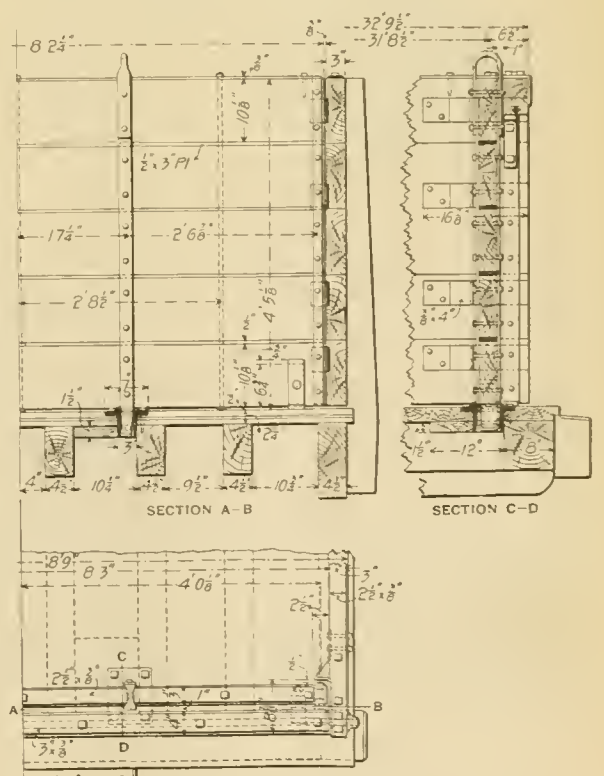

Sections of End Gates.

60,000-LB. COAL CARS—LAKE SHORE AND MICHIGAN SOUTHERN RY.

For Use with McMyler Car Dumping Machine.

fened by 4 wrought iron straps, and protected by bands of wrought iron. The doors carry lugs, which enter socket plates in the floor, and lifting stirrups at the top edge are used to raise the doors. The guides for the ends of the door are made by a 3x3 in. angle on the outside and a series of stops of $\frac{3}{8}$ x4 in. iron on the inside of the door. The doors do not lift out entirely when raised. Eight auxiliary stake pockets of $2\frac{1}{2}$ x $\frac{1}{2}$ in. wrought iron are provided. The flooring is $2\frac{1}{4}$ in. long leaf yellow pine laid crosswise. The drop openings, four in number, are 2 ft. 4 in. by 22 in., and are located between the intermediate and center floor timbers.

a great deal of light upon the hitherto obscure question of how trains are affected by the atmosphere.

The experiments were made upon small models, constructed to a scale of 1-32 of the size of the ordinary box car, the assumption being that relative resistances will be directly proportional to the surfaces of the cars, and that conclusions drawn from the small models will apply to the full size trains. Professor Goss presents the matter for practical use in the form of equations, in which the factors of the length of the train and the area of cross sections are considered, the head resistance and the resistance of the cars being provided for

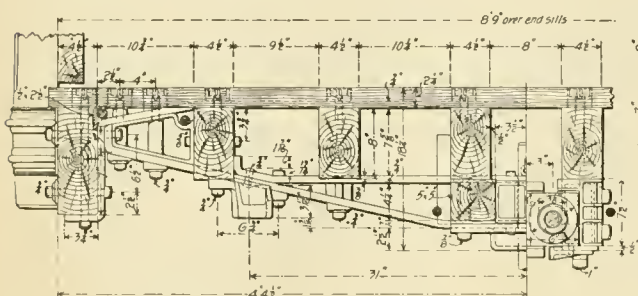

Section Showing Body Bolster.

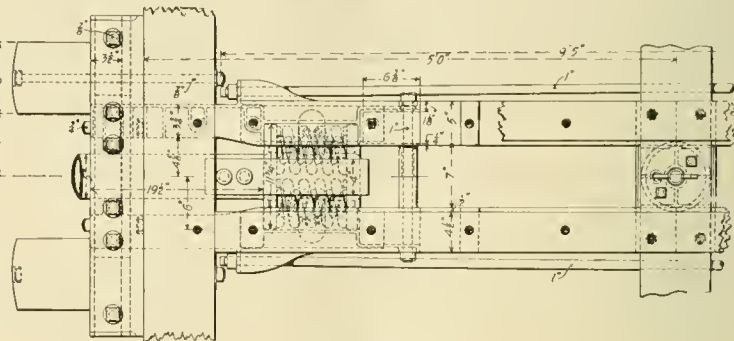

Draft Rigging.

The draft timbers are white oak, $5 \times 7\frac{1}{2}$ in., extending to the body bolsters. The draft springs are double, with two coils each. Gould draft arms are used, each being connected to the draft rod cross timbers by a one-inch rod passing through a lug on the outer side of the arm. Two $\frac{7}{8}$ in. rods connect the draft rod cross timbers.

The trucks are of the rigid, diamond frame type, with two types of bolsters, American steel and the Simplex. The drawing shows the latter. The spring plank is a 12-in. 30-lb. steel channel. At the bearing between the bolster spring plates and the truck bolster a pocket is formed in the end of the bolster,

independently. Tables worked out from these formulae give the horse power and tractive power required for speeds of from 10 to 100 miles per hour, with the locomotive and tender running alone and with a train. Tables are also given, showing the resistance of trains both with and without the locomotive, the length of trains being from 100 to 2,000 feet. These three tables sum up his results in a very convenient form, which, if the assumption referred to is correct, will be exceedingly valuable.

The apparatus consisted of a wooden conduit, 20 by 20 inches in section, by 60 feet long, the sides of glass and air tight. The air current was furnished by a blower, giving a maximum velocity of 100 miles an hour, the velocity being measured by Pitot's tubes. The model cars were placed near the center of the conduit, each being provided with a dynamometer for measuring the resistance, without attempting to obtain any data on side resistance. The limits of the velocities were 25 and 105 miles per hour, and the number of models used was from 1 up to 25. The conclusions drawn are quoted as follows:

The force with which the air current acts upon each element of the train, or upon the train as a whole, increases as the square of the velocity.

The effect upon a single model, standing alone, measured in terms of the pressure per unit area of cross-section, is approximately 0.5, the pressure per unit area as shown by the gage recording the pressure of the air current.

The effect upon the different models composing a train varies with different positions in the train; it is most pronounced upon the first model, the last model coming next in order, then all the intermediate models excepting the second, and least of all is the effect of the air upon the second model.

The relative effect upon different portions of the train is approximately the same for all velocities.

The ratio of the effect upon each of the several models composing a train, measured in pressure per unit area of cross-section, compared with the pressure per unit area of the air current, as shown by the gage is approximately: for the first model 0.4; for the last model 0.1; for any intermediate model between the second and last 0.04; and for the second model 0.032.

The chaotic condition of the experimental work on train resistance, involving, as it does, wheel, axle and flange friction; the resistance of grades, curves, and atmosphere is most unsatisfactory, and it is apparent that tests which attempt to take all of these into account simultaneously will furnish but little information, and this unique and admirable investigation seems to be a forward step in clearing up a part of this troublesome problem, the tendency of this investigation being to show that the results figured from the formulae hitherto in use are much too high. It is to be hoped that supplemental reports will be made by the same experimenter upon the internal resistance of locomotives. It will probably be too much to expect that the effects of side winds will be accurately known, but if the other factors can be isolated from each other the number of unknown quantities will be minimized. It is to be hoped that the exact relation between the resistance of the small model, and the full size car will be shown to supplement and corroborate these results.

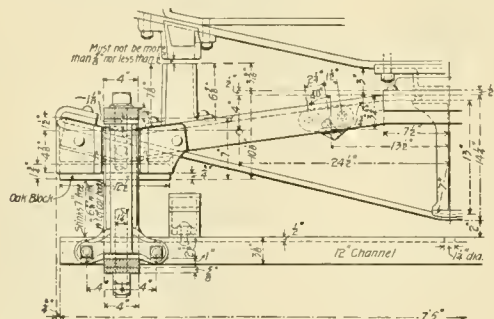

One Half of Truck Bolster.

which takes a block of oak about 12 in. square and of a varying thickness. By changing the thickness of this block the height of the coupler above the rail is readily controlled. Malleable iron journal boxes, having round bottoms, are used. Steel axles, 600-lb. wheels, graduated bolster springs and steel center plates are parts of this class of trucks. Attention is called to the large radii of the bends in the arch bars, made to insure against fracture in what are ordinarily sharp corners. The journals are the M. C. B. standard for 60,000-lb. cars.

The following special equipment was furnished: Brakes by the Westinghouse Air Brake Co.; National Hollow Brakebeams, "Peerless" air brake hose; Gould couplers; Cleveland Forge & Iron Co.'s turn-buckles. Lappin brake shoes, one-half the springs by the A. French Spring Co., and the other half by the Chas. Scott Spring Co., McCord journal boxes and Soule dust guards. The malleable castings were made by the National Malleable Castings Company. Gould spring buffers were used on 200 of the cars, 100 had the American steel bolster. A lot of 500 similar cars were ordered for the P. & L. E. R. R., from the Michigan Peninsular Car Co. We are indebted to Mr. A. M. Waitt, General Master Car Builder of the Lake Shore, for the drawings and information concerning these cars.

PROFESSOR GOSS ON THE AIR RESISTANCE OF TRAINS.

An elaborate series of tests on the air resistance of trains made by Professor Goss of Purdue University, and described in a paper before the Western Railway Club in April, throws

THE CONSTRUCTION OF A MODERN LOCOMOTIVE.*

IV.

By Motive Power.

Blacksmith Shop.

Probably in no other branch of the work required in the construction of a locomotive has there been less improvement over hand methods or in introduction of machinery to take the place of hand work than in blacksmith work. While there is good reason for much of this there remains a great deal of work now done by hand or with indifferent facilities, which, with the application of a little thought and the adoption of improved methods, can be vastly improved, not only in quality but in quantity. The blacksmith shop may be very advantageously divided into two special departments, one in which the smaller class of work is done, and which should include bolt work and all of the machinery used in connection with that and other small forgings, and the other a department in which all of the heavy forging is done, and which can properly be known as the hammer shop. By reason of the difference in the requirements it will probably be found cheaper to have the installation pertaining to the hammer shop located in a separate building, specially constructed for the purpose of getting ample ventilation, and reducing fire risks. Both of these departments should be located conveniently near to the machine shop, requiring the least amount of handling of the finished product to that point. The general arrangement of the facilities in either one of these departments should be such that the work done in them will progress in regular stages toward completion, and when completed have its location the shortest possible distance from the point at which it is to be used. All of the scrapping or making of iron, as well as the heavier forgings, is carried on in the hammer shop, at one end of which should be located, in close proximity to convenient tracks, the storage for scrap. The character, sorting, piling and other detail connected with handling of the scrap should receive the closest attention, care being used to avoid the introduction of pieces that are too small or pieces that are too large, the general character of the scrap when piled should be such that it will heat uniformly with a minimum amount of waste, which would not be the case where a wide discrepancy in the size and proportion of the pieces which make up the pile exists. With the increased use of mild steel in standard shapes, and furnished in competition with iron, there is great danger that this character of material will become mixed with the scrap, all of which is supposed to be iron. We know of no more simple and satisfactory method of sorting this out than that relying upon the man at the shear, who with proper experience can usually tell by the nature of the cut or fracture whether the piece is steel or iron. All of the scrap used should be thoroughly "rattled," and in quantities each day about equal to the consumption, for the reason that the scale or rust on the average scrap if not removed in this way becomes loosened in the heating of the pile in the furnace, and in the average process of working this pile into a bloom there is no way for this scale to work out, and it will frequently show itself in the form of dirt in seams in the finished forgings. To avoid recorrosion this scrap should only be rattled in quantities equal to consumption. The facilities for rattling this scrap should preferably consist of two tumbling barrels, located in close proximity to the scrap stored, and provided with facilities for filling and emptying large enough to handle the material in large amounts. An installation of this kind in connection with the hammer shop will more than repay its original cost in the satisfactory forgings which will result from scrap prepared in this way.

For the purpose of keeping track of the exact cost of bloom

iron made directly from the scrap, it has been found satisfactory to issue an annual work order covering its manufacture. A record of the car loads of scrap received during the current month, with a record of scrap on hand at the beginning of the month, should be kept, together with a supervision which shall provide that on or about a certain date at the end of the month there shall not be more than the correct amount of scrap on hand, generally speaking not exceeding one-half car load. This will be found an easy and simple way of keeping track of scrap consumed during that current month. Each day or night product of bloom iron should be carefully weighed, and at some convenient portion of the bloom a small portion chipped off with an ordinary cutter, and the weight and date made stamped on with steel letters; the object in cutting off this small fraction is that this surface will quickly rust and make that portion of the bloom on which the date and weight is marked more prominent when these blooms are piled in the yard. All of the forgings made in the hammer shop, and made from this bloom iron, are charged with this iron, which is carried in stock in similar manner to other material, and the forgings paid for as forgings at so much a piece, which price has been determined on a tonnage basis. Unless arrangements are provided whereby the limit weight is set, we question the economy of the tonnage system in working up forgings, and believe for the reason that it is possible to determine a limit weight, that it is more satisfactory to arrange the price on a basis of so much per forging. Owing to the isolation of the making of bloom iron from the other kinds of forgings, every facility exists for determining not only the average waste of the scrap which is used, but the cost going into the manufacture of this bloom iron in all its details. There is danger in setting too low a price on the actual work required in working up the piles into blooms, and this price per ton should be such, as to discourage scant working of the iron at this stage of its manufacture, as it has been found that a low price encourages scant working, and that the extra work required to make good the defects developing in forgings later on more than offsets the difference between too low price and one which would produce better blooms in the earlier stage of the operation. It will be obvious that some of the forgings required in the locomotive will require larger blooms than others, and to avoid unnecessary handling of heavy blooms for light forgings, a schedule of sizes or weights of blooms is prepared and used for determining the stock sizes of blooms which shall be made; the price and kind of blooms are governed by the type or class of engine under construction, and for which the forgings are required. The amount of bloom iron on hand is reported at the end of each month, and comes under the supervision of the foreman of the blacksmith shop, who has charge of both the blacksmith shop proper and the hammer shop.

Frames.—Too much care cannot be used in the forging of frames, and when finished they should have as few welds as possible. The backbone and one-half of each pedestal leg on all frames should be of one piece. Frames 28 feet long have been worked up in this way with quite ordinary facilities, with no difficulty, and when finished make a very satisfactory job. A forging of this character is made by continuous piling and working out of blooms taken from stock, each bloom being of such a size and shape that one can be made to lap on the other, and when well worked, form practically a continuous forging. For a frame whose cross-section would be about 4 by 5 inches, the blooms used for piling on should have a cross-section equal to at least 6 by 8 inches. This will insure a thorough working down of the bloom into a smaller size, and complete homogeneity in the finished forging. As stated, the pedestal legs form a part of this forging for one-half of their length down from the back bone, and the intermediate braces have solid with them the other half of the leg, from the bottom up, so that the only welds in a frame of this type will be in each one of the pedestal legs at the center of their

*For previous article see page 147.

length. This not only locates the welds where the least strain will come, but at a point where they can most easily be made, consistent with the keeping of the frames straight in piecing up, and allowance for expansion and contraction is more easily taken care of here than would be the case in back bone welds, or other old methods. Care should be taken in the making of the back bone in this way not to use too large a bloom for piling on, as the reduction to forging size at the juncture of the bloom and the finished forging is very apt to give a small section, which in the heated condition of the iron would break away. The working down of the bloom to a finished forging should be done gradually, leaving a fillet of long radius; in other words, the difference in size should not be too abrupt. The use of shaped dies in working out intermediate braces, with their portions of pedestal legs, will be found very satisfactory and will reduce the time required and also make the forgings more uniform. The welds on pedestal legs above referred to should be of the double "V" type, one side of each "V" being made at a time, and the filling piece used in this form of weld heated in a separate heat. This will practically prevent an accumulation of dirt in the weld, and also enable the forgerman to observe the condition of the weld.

Forging Presses.—Hydraulic forging presses of not less than 1,200 tons capacity, and capable of making at least 50 strokes per minute at a maximum, will be found of great value in the hammer shop in getting out the smaller forgings, which are usually worked out entirely under the hammer. One of the advantages of this class of machinery lies in the fact that it practically completes the operation on the piece in one stroke, and, the wear on the dies being very much less than in the ordinary process of hammer work, more expensive dies can be used and their life is very much greater. With a machine of this kind forgings may be worked out with not exceeding 1-16 inch to 1-8 inch finish, and in a large amount of the link and valve motion work the forgings made sufficiently close to size to only require a process of grinding for their completion.

Fires and Oil Furnaces.—In connection with a press of this type an annealing furnace should be used, especially in connection with steel forgings. The action of forming forgings of intricate shape in one heat has a tendency to change the granular structure and reduce tensile strength; this may be overcome by proper annealing and should by all means be resorted to where the forging is done in this way. In contradistinction to the hammer shop, the blacksmith shop should be equipped for all of the smaller grades of forgings, including bolts, etc., and it will be found with the introduction of machinery of comparatively simple kinds that the number of fires required in the ordinary blacksmith shop, where this machinery is located, may be very materially reduced. In this shop, and possibly some would prefer it in the hammer shop, all of the heating should be done by fuel oil supplied by means of a properly installed system and burners, which will give the maximum amount of efficiency with a minimum amount of oil. In this connection we would like to state that we do not consider any of the low pressure systems operating the ordinary forms of burners for burning this oil economical. While some of them are capable of operation without excessive smoke, it will be found in almost all cases that the oil consumption per pound or hundred pounds of product is greater than with a satisfactory type of burner using high pressure air or steam for its operation. The only proper and satisfactory way to burn fuel oil is in the form of gas, and to do this it requires a high pressure for vaporization of the oil, and a proper generating chamber for the formation of the gas. The gas formed will be found to more conveniently heat and permeate every part in the furnace in which it is burned than any flame of burning oil directly from a burner can ever do.

Bolts and Bolt Machines.—As the result of a large number of experiments it has been found that the ordinary run of

bolts can be satisfactorily headed at one operation; in other words, without the use of top, bottom and side hammers on the average bolt machine, and bolts when made of iron, headed in this way, give a better distribution of the grain of the iron in the head than where they are repeatedly hammered into shape in the average bolt making machine. It will, however, be found for some sizes that even where the average bolt machine is left to do the work in this way that the ram moves entirely too fast for the work. It requires a certain amount of time for iron properly heated to flow, and the ram in the machine must be timed accordingly to give satisfactory results. Dies for doing this work may consist of the ordinary gripping dies, which when together form practically one solid die, and the ram of the machine forming the other portion of the die practically making a closed die. The accuracy of alignment which it is necessary to maintain in the machine, will be more than compensated for in cheapness and large amount of the output. A very satisfactory form of machine for this purpose and in successful operation consists of two hydraulic cylinders, one of which operates the gripping dies and the other the heading dies. The cylinders are so arranged in connection with the operating valve that the gripping die will act first and the heading die second in the beginning of the operation and the reverse of this at the finish. A machine of this kind, capable of exerting not less than five tons pressure for every square inch of forging contact, or a total pressure of 35 tons, will be found exceedingly useful not only for bolt work but for other classes of forgings used on a locomotive, and in fact a great variety of small forging work where a large pressure is required and slowly applied. Experiment has demonstrated that the speed of this machine should be variable at will, and according to the character of the work which it is required to do. Five of these machines, varying in capacity from 35 to 60 tons, would be found equivalent to about twelve ordinary blacksmith fires. All of the iron required for bolt work should be cut to length, and can advantageously in some cases be cut sufficiently long so that two bolts can be made from one piece; in other words, a head made on each end and the bar afterwards cut in two in the center. We do not consider it good practice to make bolts of any kind where a thread is required on the end, from a bar heated for a large amount of its length. The scale which ordinarily exists on the bar is bad enough without making it worse by the additional scale, and frequently of a very much harder kind, which will form when the bolts are made in this way. Experience has demonstrated that the life of the dies used in cutting the threads on bolts which are made from iron cut to length is fully one-third more than when they are used for cutting bolts made from the bar heated for sufficient of its length to make several bolts from the one heat, and these bolts cut off in the machine. With a proper oil burner and properly constructed furnace with perforated fronts, perforations matching very nearly the size of the iron, heats can be secured on the iron in length just sufficient to make the required head, and we have seen any number of cases where the bolt iron cut to length, the heat was not sufficient in that portion of the iron outside of the furnace to discolor the threaded end. It is also true that with this kind of heating there will be very much less oil consumed than in the case where from three to four feet of the bar is heated at one time and bolts cut off in the machine. The absence of large furnaces and that class of machinery which usually is arranged in the hammer shop, which should be a separate building, will do away to a very large extent with the excessive heat and dirt in the blacksmith shop such as we have described. The introduction of oil as fuel in furnaces which do not require any stack and which would properly burn the oil together with machinery for quickly forming, in carefully made dies, the smaller forgings required on the locomotive will so materially reduce the number of ordinary forge fires required that this shop should be comparatively clean and cool. Such forge fires as are required should be equipped with oil,

thus doing away with the dust and dirt from ashes attendant on the use of coal. For the purpose of avoiding unnecessary rehandling of that class of material, the machinery for machining and cutting bolts can be arranged in the blacksmith shop in comparatively close proximity to the point where the bolts are made, and the finished product delivered directly to the erecting shop where it is used. The accumulation of short ends of bar iron, unless carefully watched, becomes a very expensive kind of scrap, for the reason that the general tendency is to cut off lengths required from a full length bar, and it frequently happens that ends left from bars of quite a respectable length will find their way into the scrap pile, and which would answer for the regular run of bolt work. At some convenient point in the shop a series of bins sufficient in number to cover the average range of sizes, should be arranged to contain these short ends, and they should be regularly collected from the smith fires or points where they are likely to accumulate and put in these bins. The lengths which will average about the same should be selected from time to time and used up on running orders of bolt work. This will not only prevent pieces of excessive length accumulating in the scrap, but will use up the material more closely and economically. At the end of each month these bins should be carefully gone over and the shortest pieces which would answer for scrap taken out, their weight kept, and thrown in the regular scrap stock, which stock should receive credit for that amount of material and that credit reported in the regular way to the keeper of stores. It also happens that from time to time there is an accumulation of scrap of sufficient size for working over in the various other departments, and this scrap should be regularly sent to the regular scrap pile, the weight being carefully taken, and the scrap stock given credit in similar manner to the case above referred to.

Finishing Forgings.—Located in the hammer shop, there should be several cold saws of sufficient capacity for the heaviest forgings which will require trimming. These forgings can go direct to the saws from the hammers, and in many cases the trimming which these saws will do will be all the machine work which will be required on that surface. An installation of from three to four machines provided with an automatic saw sharpener and proper lifting appliances can be readily handled by one man; as the forgings leave these saws they will be ready for delivery to the machine shop. The location of these saws in the hammer shop will save the handling of what otherwise would be much heavier forgings, as well as the transfer back of the scrap stock of material removed by the saws in case they were located in the machine shop.

Tools and Tool Making.—In the blacksmith shop should be located a separate department in which all of the forgings required for tools and all of the hardening and tempering, annealing, etc., is done, and in charge of an experienced man. Outside of the tools required at the hammers, all of the tools used by the blacksmiths should be made in this department and taken charge of by this department. It is not considered good practice to allow the indiscriminate manufacture of tools by the blacksmiths throughout the shop, as they can be made very much more quickly and cheaply in a department provided with the proper facilities for that purpose. These facilities may consist in addition to forge fires principally of either hammer or hydraulic presses, provided with dies of the proper shape to form in one or not exceeding two operations the complete tool required. All of the tool steel required throughout the works may be carried in this department, and each lot of tool steel received should be subject to a careful test by the man in charge, who must thoroughly understand the manipulation of this material. We have known cases where several hundred dollars' worth of steel has been made into tools and proved utterly worthless, owing to change in the mixture by the manufacturers of which the consumer was not aware of at the time of its receipt. The

test applied need not be elaborate and may consist of the usual drawing out, annealing, hardening and bending under various conditions, and also the hammer refining test. A record of these tests either by retaining the original pieces, or careful description with the maker's name, of the steel will serve as an indication of how uniform the steel furnished may be running, and it is preferable that the man in charge of this department should work in close harmony with the man who has charge of the small tool department, and who manufactures the steel into the finished shape.

Order of Doing Work.—Both the hammer shop and blacksmith shop having been supplied with a schedule for the getting out of the parts referred to in previous article, the order in which the forgings and material from both departments will be furnished will be in accordance with the requirements of the erecting shop, making proper allowance for the time required for machine or finishing in the machine shop. Generally speaking the heavier classes of forgings, such as frames, guide yokes and other forgings which pertain to frame work direct, as well as the forgings which are provided for the boiler, are required first. Whether the practice may be that of cutting off the stay bolts to length and screwing them in with a special nut for the purpose, or providing a square on the ends for the purpose of screwing them in, in all cases the bar should be marked or stamped on the square indicating the make of the stay bolt iron, for the purpose of designating this iron until it is used up and in order to keep careful record of the kind of stay bolt iron used in any one particular class of boilers. It has been found convenient where squares are provided on the end of the bolt to stamp the letter in the heading die so that with each operation of forming the square the letter is stamped on the end of the rod. It is of course understood that in all of the larger forgings such as frames, guide yokes, rods, etc., that these forgings leave the hammer shop ready for machining in the machine shop, and that the welding up or piecing up of frames is done in the hammer shop, the blacksmith shop proper being reserved entirely for the smallest grade of forgings required in the construction of the locomotive.

COLLEGES.

Cornell University, Summer School, Announcement of Courses of Instruction.—The summer school of Cornell University, for teachers and advanced students, will be open this year from July 5 to August 13, and those interested may obtain copies of the announcement on application. A number of courses have been arranged for those who desire to advance themselves as draftsmen, engineers and electricians, open to any one without entrance examinations. Among these are: Dynamo laboratory practice and lectures, mechanical drawing and designing and laboratory work. The last mentioned course includes the testing of materials and lubricants, determination of quality of steam; analysis of coals and flue gas; calibration of dynamometers, weirs, steamgages, steam-engine indicators, and other engineering apparatus; efficiency tests of the hydraulic ram, water motor, injector, boilers, pumps, air compressors; steam, gas, oil, and hot air engines. For further particulars the circular should be consulted.

West Virginia University, Announcement for the Summer Quarter 1898. This circular contains a statement of the work of the university for the advantage of students who do not wish to lose the time during the summer vacation. The drawing room, field practice, shops and laboratories will be open during the summer. Information may be had from Wm. S. Aldrich of the Department of Mechanical Engineering, Morgantown, W. Va.

Massachusetts Institute of Technology, Entrance Examinations.—The usual plan of holding entrance examinations for this school in twenty-one different cities of the United States on June 30 and July 1 will be carried out this year, particulars of which may be obtained from Dr. Harry W. Tyler, Secretary, Boston, Mass.

SIMPLE TEN-WHEEL LOCOMOTIVES WITH PISTON VALVES—WISCONSIN CENTRAL LINES.

Four ten-wheel passenger and six freight locomotives of the same type have just been delivered to the Wisconsin Central Lines by the Brooks Locomotive Works. The drawings are specially interesting because of the application of piston valves. The passenger engines have 69-inch and the freight 63-inch driving wheels, while the cylinders of the passenger are 19 by 26 and of the freight 20 by 26 inches. The weight of both engines in working order is about 150,000 lbs. The heating surface is 2,300 square feet and the grate area 32.4 square feet. The piston rods are 4 inches in diameter. The steam ports have an area of 36 square inches and the exhaust ports an area

drivers, the forward drivers being connected across the engine to an equalizer in the form of a 46-inch spring, which rests on saddles over the driving boxes. The heavy springs have 6 by 1/2-inch leaves. We are informed that the engines ride remarkably well. The springs have long hangers which will tend to reduce the amount of wear on the ends of the springs to a minimum. This is important and is not always well provided for.

The front and rear end of the frames are unusually deep, and at the cylinders they are 3 inches wide and 10 inches deep, the tongues are 8 inches deep at the frame splices and 9 inches deep in front of the cylinders. The pistons are of the bull ring type, hollow with three packing rings. The front cylinder heads are cast iron and the rear ones cast steel and very thin and light. The steam chest covers are circular and the forward

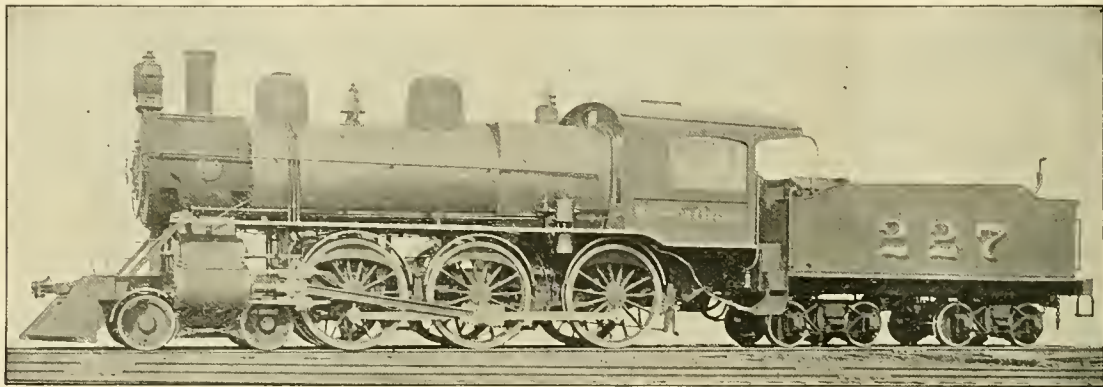

Wisconsin Central Engines—From Photograph.

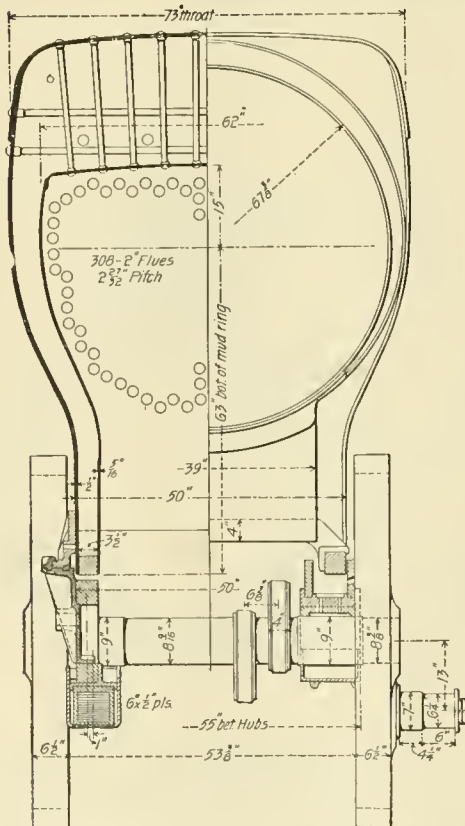

Section Through Firebox and Main Driving Box.

of 65.5 square inches. The boiler is the Player patent, Belpaire type with a sloping firebox over the frames. The passenger engines have truck brakes and all of the engines have the arrangement of spring hanging shown in one of the engravings, in which a 42-inch spring is employed as an equalizer while the other driving springs are elliptic with curved levers resting on the tops of the driving boxes for the main and rear

ones have stuffing boxes to receive the extended valve rods, and with this plan the valves should be perfectly balanced. It is open to question, however, whether the pressure of the steam under these rings will not cause considerable friction against the bushings.

On page 3 of our January issue and again on page 85 of our March issue, of this volume, we illustrated the piston valves made by these builders for the Great Northern engines, and a comparison will be interesting. The valves of the Wisconsin Central engines have internal admission, and the inside clearance of 1/8-inch is at the outside edge of the valves, while the steam lap is on the inside. This arrangement brings the live steam to the center of the valve through a passage that is surrounded by exhaust steam, and in this respect is similar to the design of piston valves by Mr. G. R. Henderson, shown on page 39 of our February issue. The form of the valve and the bushings and packing are shown in the engraving. The packing for the freight engines is like that of the Great Northern design and is shown in place in the sectional drawing of the valve.

In the arrangement for the passenger engines the Z shaped rings are cut at an angle of 45 degrees, the lower ring is cut square across to fit the dowel pin that is held in place by the follower plate and the upper ring is prevented from turning by cutting the rib out to admit the head of the dowel stud that is screwed into the lower ring. The Z shaped rings are turned 1/8-inch large, cut and sprung into the top ring. A glance at the end view of the valve will show the location of the dowel pin in the valve packing. The valve is thin, being only 3/8-inch thick in the shell, which is hollow. The valves work in cylindrical bushings, which are removable from the cylinder castings. They are 3/4-inch thick and have six steam ports of which two are 4 inches long and the rest 2 1/2 inches, all of them being 2 inches wide and having 1-inch bridges between them. The bushings are held in place by set screws, as shown.

These engines are fitted with Mr. J. Snowden Bell's patent arrangement for the front end draft appliances. The most novel features except the valves are the cylinder frame fastenings and the spring hanging. Mr. James McNaughton, Superintendent of Motive Power of the road says the spring rigging is "a decided success."

The valve gear is also novel. The rocker arms are both at the same end of the rocker shaft and both inside the frames, and there is but one tumbling shaft arm instead of two, the arrangement being shown in the section taken through the guides. The engines are doing excellent work and the use of this type of valve is another step toward what many people think will be common practice in a few years. The following table gives the chief dimensions of the engines, both freight and passenger:

CAR FOR TRANSPORTATION OF HORSES, C. & N. W. RAILWAY.

The car shown by the accompanying engravings is constructed as a baggage car and intended for transporting horses and the fittings are so arranged as to permit of the use of the car for baggage or other purposes, the partitions and special equipment of the car being stowed out of the way, when necessary. We have received the drawing and photograph from Mr. C. A. Schroyer, Superintendent of Car Department of the Chi-



View of One End of Car.

cago & Northwestern Railway. The car is known as the "Northwest." It is 50 feet long over the end sills, 9 feet 10 inches wide, 14 feet high from the rail to the top of the deck, 49 feet 4 inches long inside and 9 feet 2 inches wide inside. Iron cross beams receive movable stanchions carrying partitions forming the stalls and these may be moved to one side along the cross beams, as indicated in the drawing. The engraving from the photograph shows one end of the car with

Type.	10 Wheel Passenger.	10-Wheel Freight.
Gage	4 ft. 8½ in.	
Kind of fuel to be used	Bituminous coal.	
Weight on drivers	116,000 lbs.	115,000 lbs.
" trucks	34,600 "	34,000 "
" total	151,000 "	149,000 "
Average	75,000 lbs.	
Weight tender loaded maximum	94,000 "	
Wheel base, total, of engine	21 ft. 9 in.	
" driving	14 ft. 6 in.	
" total (engine and tender)	52 ft. 2 in.	
Length over all, engine	38 ft. 2 in.	
" total, engine and tender	62 ft. 6 in.	
Height center of boiler above rails	8 ft. 11 in.	8 ft. 8 in.
" of stack above rails	11 ft. 11½ in.	14 ft. 8½ in.
Heating surface firebox and arch pipes	189 sq. ft.	
" tubes	2111 "	
" total	2300 "	
Grate area	32.4 "	
Drivers' diameter	69 in.	63 in.
" material of centers	Cast steel	
Truck wheels, diameter	33 in.	
Journals, driving axle, main	9 in. x 11 in.	
" front and back	8½ in. x 11 in.	
" truck	5½ in. x 12 in.	
Main crank pin, size	6¼ in. x 7 in.	
Cylinders	19 x 26 in.	20 x 26 in.
Piston rod, diameter	4 in.	
Main rod, length center to center	119 in.	
Steam ports, length	18 in.	} area, 36 sq. in.
" width	2 in.	
Exhaust ports, length	2½ in.	
Bridge, width	Least area, 65.5 sq. in.	
Greatest travel of valves	7 in.	
Steam lap (inside)	1½ in.	
Exhaust lap or clearance (outside)	¾ in. clearance	
Lead in full gear	.76 in.	
Boiler working steam pressure	200 lbs.	
" thickness of material in barrel	¾ in.	
" tube sheet	¾ in.	
" diameter of barrel	66 in.	
Seams, kind of horizontal	Quintuple.	
" circumferential	Double.	
Dome, diameter	30 in.	
Firebox, type	Sloping, over frames.	
" length	113 in.	
" width	41 ¾ in.	
" depth, front	78 in.	
" back	60 in.	
" thickness of sheets	Side, 5/16 in.; crown and back, 3/8 in.; tube, 5/16 in.	
" brick arch	On water tubes.	
" mud ring, width	Back, 3½ in.; sides, 3½ in.; front, 4 in.	
" water space at top	Back, 4½ in.; sides, 5 in.; front, 4 in.	
Grate, kind of	Rocking.	
Tubes, number of	308	
" outside diameter	2 in.	
" thickness	No. 12 B. W. G.	
" Length over tube sheets	13 ft. 2¼ in.	

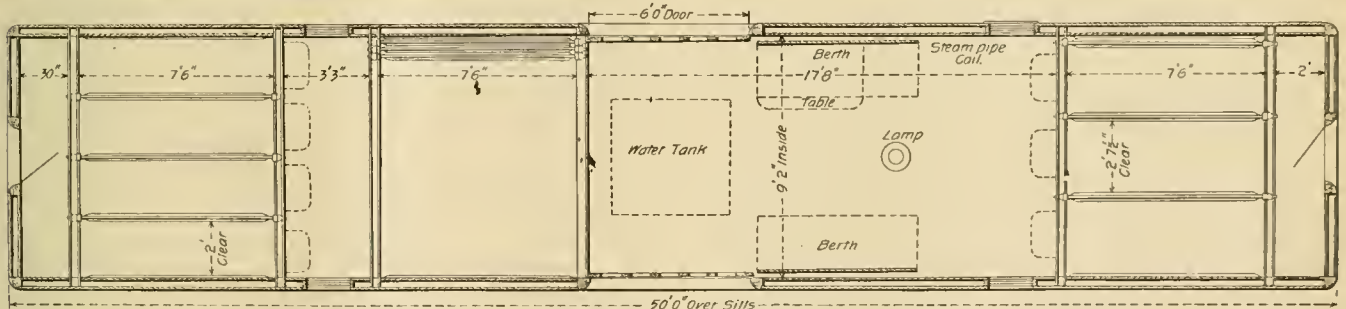

Car for Transporting Horses—C. & N. W. Railway.

Smokebox, diameter outside	69 in.
" length from flue sheet	63 in.
Exhaust nozzle, diameter single	4¾ in., 5 in., 1½ in.
" distance of tip above center of boiler	1 in.
Stack	Taper.
" least diameter	15¾ in.
" greatest diameter	18 ¾ in.
" height above smoke box	38 in.
<i>Tender.</i>	
Type	Eight wheel, steel frame.
Tank capacity for water	4,500 gals.
" coal	8 tons.
" material	Steel
Tank, thickness of sheets	1/8 x 3/4 in.
Type of under frame	Steel channel.
" springs	1/2 elliptical.
Diameter of wheels	33 in.
" and length of journals	4¼ in. x 8 in.
Distance between centers of journals	6 ft. 3 in.
Diameter of wheels fit on axle	5¾ in.
" center of axle	4¾ in.
Length of tender over bumper beams	22 ft. 4 in.
" tank	19 ft. 6 in.
Width	9 ft. 10 in.
Height of tank not including collar	3 ft. 10 in.
Type of draw-gear	M. C. B. Standard.

four stalls, made up with the canvas feed hags in position, while the drawing shows the plan of the car, giving the chief dimensions. Stable room for 12 horses is provided, the stalls are made adjustable so that the width may be changed even to the extent of providing three box stalls. The sides, ends, roof and floor are insulated with paper, the car has passenger platforms, 6-wheel trucks, air brakes, air signal and steam heating apparatus. A 100-gallon water tank is secured to the roof of the car with pipe connections to a sink hinged to the side of the car, so that it may be folded up out of the way. A table is also hinged to the side of the car for folding up when not in use. Canvas collapsing sleeping berths for two men are provided and a tool and a hay box are carried underneath the car floor.

THE WAR RELIEF FUND.

One million dollars is to be raised for the work of the American National Red Cross, of which Clara Barton is president, and of the Central Cuban Relief Committee, appointed by the President of the United States. Our assistance has been asked by the publishing house of Funk & Wagnalls Company, who have generously undertaken to aid in the collection of money which we understand is to go directly to the relief work, absolutely without any deductions or commissions. Money sent to our publication office, Morse Building, New York, will be promptly forwarded to Funk & Wagnalls, who will send a copy of the lithograph, "The Accolade," to those who donate \$1.

THE HORSE POWER OF LOCOMOTIVES.

The usual method of rating the power of locomotives by the tractive force at full stroke is useful only for starting conditions and at very slow speed. While it may be a convenient figure for comparing the power of different locomotives in a rough way, it is of little use in determining their power under working conditions and average speed. The important thing in locomotive design is to select proportions so as to secure the best possible results under the conditions with which most of its work is done. It has taken a long time for us to realize that starting power is not the most essential thing, and that the best working proportion need not be made for that stage of operation. This is well illustrated by valve proportions. Until recent years lead was always stated at full stroke and little consideration was given to what it might be, or what its effect would be at the regular working cut off. It is now the custom in best practice to pay particular attention to lead in average cut off, and secure the best steam distribution at that point. In like manner we are awakening to the fact that economical working requires that the locomotive should do its best work at the average running speed and that the greater the power obtained at such speed (without sacrificing essentials at other speeds) the more efficient will be the machine. We have, then, to consider the combination of tractive power and speed or horse power which is measured by 33,000 foot pounds per minute. The fact that tractive power decreases with speed and

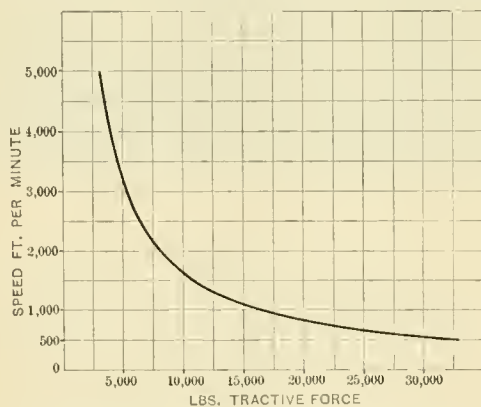

Curve for 500 Horse Power.

cut off, while taken account of in a general way, has not been thought important enough to necessitate determining, in many cases, the rate at which that decrease takes place.

The study of indicator cards for this purpose, and the combination of the tractive power thus found at different cut offs, with the speed, making a horse power curve, has rarely been resorted to. We may therefore describe this new method of rating locomotives, as the "horse-power curve." This curve, will, of course, vary with different combinations of cylinders, boiler pressure and wheels. The theoretical curve can easily be drawn for any horse power by plotting the speed upon the tractive power, as in the accompanying diagram. Then by means of indicator cards at different working cut offs with the speeds carefully noted, the tractive power at different speeds is obtained. For this purpose, an accurate speed recorder is necessary, and the cut offs in even inches should be marked on the reverse quadrant. The tractive power multiplied by the speed of the engine in feet per minute gives the horse power for different speeds, and this when plotted on the same sheet with the theoretical curve will show at a glance how near the actual performance of the engine approaches in practice to the theoretical power. It will show also, if there is a departure from the theoretical curve at working speed, that it may be desirable to make some change in the size of cylinder or wheels.

In working long grades and in running passenger trains at high speeds with long intervals between stops, it is necessary that the maximum horse power of the locomotive shall be sustained for long periods, and under such conditions any weak points of design, either of engine or boiler, will be shown. When analyzed into its component parts the horse power for any given engine has two principal variables, one the speed which is independent of the design, the other the tractive power, which depends not only on cylinders and wheels, but also on the boiler. With cylinders and wheels given, the tractive power depends principally on the mean effective pressure in the cylinder, and for high tractive power the aim therefore should be to obtain the highest possible mean effective pressure. The highest mean effective pressure is only obtained by the best proportion of valves and ports and the best valve motion. It also depends upon continuous full boiler pressure.

In using indicator cards for horse power curves, it is there-

fore important to select these taken under such working conditions as will enable the engine to maintain full boiler pressure. To obtain this under maximum load requires good boiler design with best proportions for grate and heating surfaces. It will be seen from this that the maximum horse power in a locomotive involves nearly all there is in the best design for both engine and boiler, and it thus becomes a very good measure of the true value of the locomotive as a hauling machine. Measured in this way we may say that for any given type of locomotive having proper driving wheel adhesion, that one is the best which develops the greatest horse power at the normal working speed for each ton or pound of total weight of engine. If we take E to represent this kind of efficiency, and W the weight of the engine, then $E = \frac{H P.}{W}$.

This presentation may appear to be very simple and elementary, but it will serve as an introduction to a method which will be found very useful in determining the proper proportions for locomotives intended for heavy grade work at slow speeds as compared with those in ordinary service at medium speeds, and also for passenger locomotives which must sustain high speeds for long distances.

THE HORWICH LOCOMOTIVE WORKS OF THE LANCASHIRE & YORKSHIRE RAILWAY, ENGLAND.

By William Forsyth.

Although the Horwich shops are the largest locomotive repair shops in the world, they are comparatively unknown to most American master mechanics, and a general plan of the works and a brief description of the principal departments will probably prove interesting. The buildings were commenced in 1886 and the shops were in running order in June, 1889, at the time the American engineers visited England. The contingent which was fortunate enough to visit Horwich at that time has not yet ceased to marvel at the vast extent of the works and the substantial character of the buildings. The plant was entirely completed in 1892.

To the present Chief Mechanical Engineer of the road, Mr. J. A. F. Aspinall, was assigned the duty of superintending the erection of the works, the arrangement of the machinery, and starting them as a working establishment. The land inclosed for the works includes 85 acres and the covered area of the shops is $13\frac{1}{2}$ acres. In addition to the ordinary 4 feet $8\frac{1}{2}$ inch gauge railway connecting the various parts of the works there is a narrow 18-inch gauge railway traversing every part of the plant, its total length being $6\frac{1}{2}$ miles. It is worked by small locomotives, with trains conveying materials and finished work between the several departments. An open passenger car with seats, back to back, is also used on this line for the convenience of visitors and officers.

The main line of the Lancashire & Yorkshire Railway runs east and west across England, and is only about 300 miles long, but it has numerous branches. The equipment consists of over 1,000 locomotives, and they are all renewed or repaired at this one shop. All other iron and steel work for the line, except cars and bridges and rails, is manufactured here. The plant is remarkable for the number and size of the buildings, there are twenty different departments, and ten of the large shops have a uniform width of 111 feet. Some of the products of the establishment are unusual in railroad shops abroad, and are never found connected with American railroad shops. These are the large steel foundry, a 14-inch merchant rolling mill, an 8-inch guide mill and a chain shop. The office is 323 by 58 feet, two stories high, and besides the accounting offices, contains a large drafting room and a testing room and laboratory. The storehouse is also a two-story building, 198 by 111 feet, the second floor having a gallery, leaving a light well at the center.

The boiler shop is 439 by 111 feet, arranged in three bays, the first for building and repairing boilers, the second for tenders, tanks and miscellaneous sheet iron work; the third for tools, drills, punches, shears, etc., and each bay is provided with an overhead travelling crane. The rivet furnaces are heated by oil, sprayed by compressed air. At the end of the shop the roof is carried up 16 feet higher to form a riveting tower. The flange shop, adjacent to the boiler shop, is 120 by

111 feet, and contains hydraulic flange presses for boiler heads, tube plates, etc., gas furnaces being used for reheating plates. The forge is 452 by 111 feet and is located next to the foundries, on account of a side hill which provides an upper level for the gas producers and charging platforms. The natural formation of the ground at this point is 14 feet higher than

walking crane for handling heavy pieces to the machine tools. There are four lines of shafting running the length of the shop and driven by two wall engines at one end. A series of tools are employed in finishing cylinders, and a number of large milling tools, both vertical and horizontal, are provided for finishing rods and valve motions. Other portions of the shop

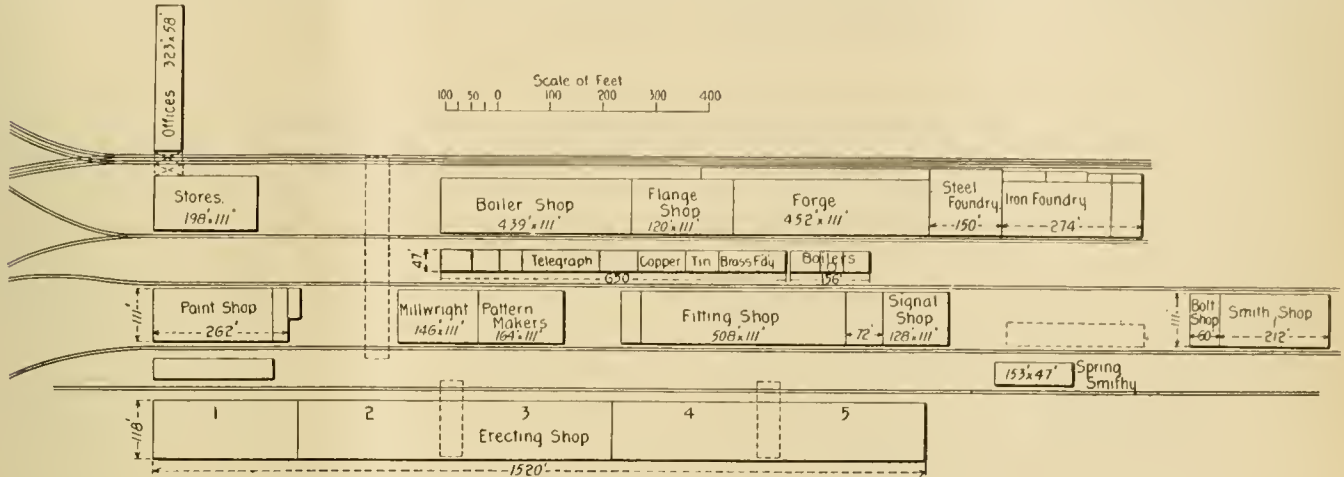

Ground Plan, Horwich Shops—Lancashire & Yorkshire Railway, England.

the rail line of the shops. The forgings are heated in gas furnaces, the scrap being cut up on the high level and taken by power conveyers to the furnaces. This building contains the 12-inch and 8-inch rolling mills. The smaller smith forging is done in several other buildings. The flange shop contains several forges for boiler forgings. The large blacksmith shop or smithy, as it is called, is 212 by 111 feet, containing 33 single forges and 11 double forges. The bolt shop, 60 by 111 feet, contains bolt, nut, rivet and nail machines, as well as drop hammers for die work. The spring shop, 153 by 47 feet, has two gas spring furnaces and hydraulic spring machinery.

The steel foundry, 150 by 135 feet, contains one 20-ton and two 10-ton Siemens-Martin regenerative melting furnaces, heated by gas from their own series of gas producers. When a railroad is provided with its own steel foundry, the tendency is to substitute steel castings for forgings in locomotive details as far as possible, and the extent to which this has been done on the Lancashire & Yorkshire is shown by the constant use of so large a steel foundry. Steel centers for driving wheels and centers for steel tired wheels for trucks are among the heavier castings produced.

The iron foundry, 212 by 111 feet, is used for general castings, not only for locomotive work, but for cars and roadways. The wheel shop, 165 by 47 feet, is near the foundries, and contains wheel boring mills and lathes. The passenger car wheels are put together in this shop, and a special hydraulic press is provided for forcing the wood blocks between the wheels centers and the tire. It is not so long ago since the locomotive driving wheels on the Fort Wayne road were built up in this way, but the hickory blocks were driven in by sledges.

The boiler house, 156 by 47 feet, contains two nests of five boilers each. These are connected with two sets of Green's economizers. The only use for electricity here is for light and an engine and dynamos supply light to one end of the works and also to the offices.

A series of long, narrow buildings, 47 feet wide, contain the brass foundry, 105 feet long, tinsmith, 150 feet; coppersmith, 90 feet; tube cleaning and case hardening, 75 feet; telegraph shop, 153 feet; a special shop, 128 by 111 feet, is provided for the manufacture of signals, and another, 72 by 111 feet, for frogs and crossings. We now come to the two principal shops, the machine shop, marked on the plan as the "fitting shop," and the erecting shop.

The machine shop is 508 by 111 feet. It has cross-track communication with the erecting shops and is provided with a

are devoted to brass finishing, a tool room, and at one end are the rod gangs and work bench fitting, where the small amount of necessary hand work is done. The shop is heated by pipes in trenches covered with chequered gratings, which also serve for the narrow gauge tracks, grooves being cast in them for this purpose. The artificial light is afforded by inverted arc lamps under large white painted wood disks suspended from the roof trusses.

The erecting shop is the most remarkable of all the buildings, on account of its great length. It is 1,520 feet long and 118 feet wide, and has a capacity of over 100 locomotives at one time. It is divided into two large bays and one smaller bay in the middle of the shop. The outside bays are used for repairs and renewals of locomotives, the small middle bay being used for fitters' benches and for small tools, such as drills, placed at suitable positions along the shops, and for the storage of materials. The erecting shops are divided into Nos. 1, 2, 3, 4 and 5 respectively. The No. 1 shop is used for the erecting of new tenders and repairing of existing stock. Of No. 2 shop about one-quarter is taken up for boiler mounting; the boilers being received from the boiler shop are here fitted with tubes and the brass mountings; they are also tested both with water and steam before being sent to the erectors; the other three-fourths of the shop are taken up with general locomotive repairs. Nos 3 and 4 shops are exclusively used for locomotive repairs. No. 5 shop is mainly used for locomotive repairs, but a small portion is set apart for new work. Each outside bay of each erecting shop is provided with two 36-ton overhead traveling cranes, making twenty in all. Wheel lathes are provided at various parts of the erecting shops for dealing with the wheels taken from the locomotives under repair. A number of portable hydraulic riveters are also provided. Access for locomotives to the center portion of the shops is provided by two traversers, or transfer tables. As the machine shop, boiler, flange, and erecting shops have the same width, their area is proportional to their length and we find that the total length of the boiler and flange shops is about 50 feet longer than the machine shop, and the erecting shop is about three times the size of the machine shop.

Much as we may boast of our American railways and locomotive shops we have nothing in this country to be compared with the Horwich shops as locomotive repair shops. A visit to them is an inspiration, and only by seeing them can one get an idea of the vast plant which is necessary for the maintenance of the machinery of a large railroad having a dense traffic.

LOCOMOTIVE CHARACTERISTICS.

By G. R. Henderson, Mechanical Engineer Norfolk & Western Railway.

At the present stage of railroad development, when all efforts are turned toward the economical construction and operation of equipment, the locomotive has naturally come in for its share of study, and its power and efficiency have been freely discussed and criticised. Economical operation does not necessarily mean a great amount of work done by a small amount of fuel, but more frequently, a great amount of work by a small number of engines, or in other words, the quantity of work done by a locomotive is of more importance than the economy of fuel shown by the same locomotive. It is the object of this article to determine the conditions under which the maximum amount of work or power can be obtained from any given locomotive, of known proportions, regardless of the fuel economy.

The study of indicator diagrams taken from locomotives clearly shows that the highest horse-powers are obtained with the high speeds, and we shall first endeavor to determine the law between speed and power. It must be borne in mind that the power of the locomotive is determined by the boiler, and that there is a limit to its steam producing capacity.

Let us first produce an equation between the amount of steam supplied by the boiler and that used by the cylinders, and consider that:

- v=volume of both cylinders, in cubic feet (this refers to simple engines only);
- b=ratio of grate area to cylinder volume (square feet to cubic feet);
- c=maximum rate of combustion in pounds per square foot of grate area, per hour;

$$2 \times a \times 1.2 \times 1.25 \times 60 = \frac{b \times c \times d}{b \times c \times d} = \frac{2 \times a \times 1.2 \times 1.25 \times 60}{b \times c \times d}$$

which is the equation of an hyperbola, referred to its asymptotes as axes.

If we assume the values for a, b, c and d = 0.284, 3, 160 and 6 respectively, we have $x y = \frac{2 \times 0.284 \times 1.2 \times 1.25 \times 60}{3 \times 160 \times 6} = 56.33$

illustrated by the curve A-A, of Fig. 1. This line will be understood to show the latest cut-offs that the boiler will supply with steam at the various speeds shown by the abscissae, the ordinates representing the proportion of cut-off. The valve gear prevents a later cut-off than 90 per cent.

We now proceed to construct a curve, which will give the "maximum mean available pressure" for the different speeds, and by this we mean the mean effective pressure, with the friction of the engine deducted, or the net effective pressure on the pistons.

Diagram No. 2 of the Master Mechanics' Association report above mentioned [this diagram is reproduced here as Fig. 3, and Fig. 1 from the same report is reproduced as Fig. 4. They will be found also in our issue of July, 1897, page 251.—Editor] gives the ratio of mean effective pressure to initial pressure for various speeds and cut-offs, and allowing in addition 5 per cent. drop from boiler pressure to initial pressure, and 8 per cent. for engine (internal) friction, we have the results of the diagram multiplied by 0.95×0.92=say 0.88, with which to construct the line B-B, which shows the maximum mean available pressures which can be obtained at the various speeds. This allows for the internal friction of the engine, but not for the journal and rolling friction.

It is to be noted, that a strict interpretation of the line

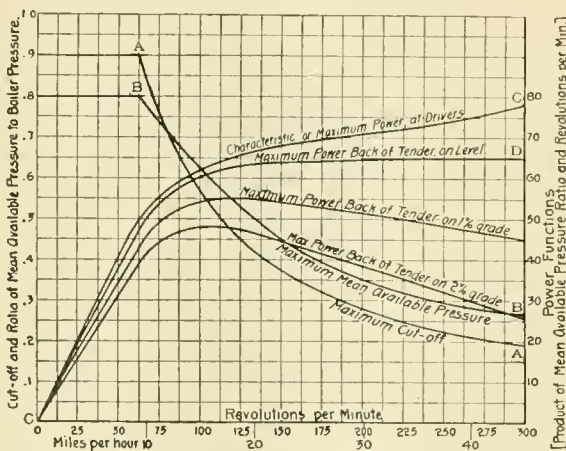

Fig. 1.

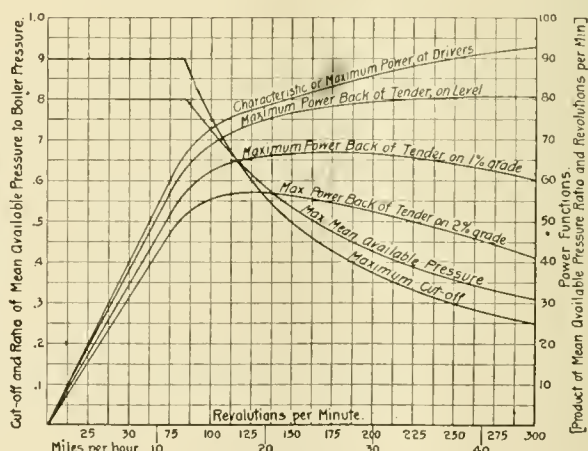

Fig. 2.

d=evaporation rate under the assumed conditions, from and at 212 degrees.

Then the maximum quantity of steam which the boiler can supply in pounds per hour,

$$=v \times b \times c \times d, \text{ from and at } 212 \text{ degrees.}$$

(The values of these factors under different conditions may be obtained from the report on "Grate Area and Heating Surface," made last year to the Master Mechanics' Association, see page 218 of the proceedings for 1897.)

Let x=cut-off ratio in the cylinders;

y=revolutions per minute;

a=weight in pounds of a cubic foot of steam at cut-off pressure;

then, allowing 1.2 for the factor of evaporation (from 212 degrees to working pressure), and 25 per cent. for cylinder condensation, we have the weight of steam used per hour, in pounds;

$$=v \times x \times 2 \times y \times a \times 1.2 \times 1.25 \times 60, \text{ from and at } 212 \text{ deg.}$$

A-A of maximum cut-offs, would require the left-hand end to be slightly dropped, as at slower speeds, the cut-off pressure and weight of steam would be greater, and therefore reduce the permissible cut-off, but other authorities indicate that the hyperbola can safely be used.

As the tractive force of a locomotive is expressed by the

$$\text{formula } \frac{p \cdot d^2 \cdot S}{D}$$

per square inch; d=diameter of cylinders in inches; S=stroke in inches; D=diameter of drivers in inches; the tractive force will be a function of the ordinates to the curve B-B, and will therefore vary as, or be proportional to, these ordinates. This shows that the tractive force is a maximum at low speeds.

The work or power developed by a locomotive is the product of the tractive force and the speed, and as we have just shown that the tractive force is proportional to the ordinates of the

curve B-B, the work done will be proportional to the product of the ordinates and abscissae of the curve B-B. This is represented by the curve C-C, which has been produced simply by multiplying together the co-ordinates of B-B, and laying off the product on the corresponding abscissae as ordinates. This curve we call the "Characteristic of the Locomotive."

It is interesting to note how this line rises, rapidly until the capacity of the boiler is reached, when it assumes a nearly horizontal direction, rising more rapidly, however, at high speeds. This gradual rise is probably due to the economy of using steam at shorter cut-offs. In reading the numerical values of this curve, be governed by the values at right side of diagram. Of course the line C-C must be understood as showing the ratio of power at the circumference of the drivers.

The point of greatest interest to the transportation department is, however, the power back of the tender coupler, or,

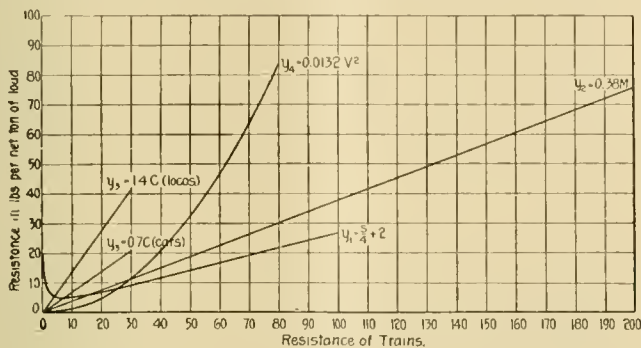

Fig. 4.

with the proper allowances for the resistance of the engine and tender. C-D has been formed by subtracting from C-C, the power necessary to move the engine and tender at the speed in question, on a level track, the resistance due to speed being taken from diagram No. 1, of the Master Mechanics' Report, above referred to, shown here in Fig. 4. For allowances for grades of one and two per cent., the additional deductions have also been made, and the corresponding curves produced. The values to be deducted bear the same ratio to the resistance of the engine and tender, as the curve C-C does to the total power of the engine.

In making these deductions it has been assumed that the locomotive in question has 20 by 24 inch cylinders, 50 inch drivers, and weighs 100 tons complete with tender.

From these various curves we conclude that:

1st. The power at the drivers increases with the speed, although it remains nearly stationary at velocities near 200 revolutions per minute.

2nd. The power or work done back of tender reaches its maximum at a speed of 20 miles per hour, or 135 revolutions per minute, and remains constant for increasing speeds, when working on a level.

3rd. The power or work done back of tender is a maximum at about 18 miles per hour, when working on a 1 per cent. grade.

4th. The power or work done back of tender is a maximum at about 15 miles per hour, when working on a 2 per cent. grade.

5th. Omitting the question of speed, and also work or power, the maximum tractive force is developed at speeds of 10 miles per hour and less.

Of course it must be remembered that these results pertain only to an engine of the proportions assumed for the present case, and that every engine to be considered in this way should have its proper curves laid out.

By referring to the first formula, it can be readily seen how a change in any of the vital dimensions or proportions will affect the curves. For instance, let us assume that "b," the ratio of grate area in square feet to the total cylinder volume in cubic feet, shall be 4 instead of 3, or the grate to be one-third larger, with the proper proportion of heating sur-

face, but same total weight of engine and tender. Now it is evident that one-third more steam would be produced, and therefore the hyperbola A-A, instead of being represented by the equation $xy=56.33$, would be expressed by the equation $xy=75.11$. This curve, with its mates as before explained, is shown in Fig. 2. It will now be seen that as a result of the additional steam advantages, the maximum points are much greater in power, besides exerting these maxima at increased speeds. For instance, at a level the maximum work or power back of tender is found at speeds of 30 miles an hour and upward; on a 1 per cent. grade, at 25 miles per hour; and on a 2 per cent. grade, at 20 miles per hour. This is the direct advantage of having a boiler of greater capacity, and its lesson cannot be ignored.

The foregoing remarks are merely intended to introduce the method of analyzing a locomotive by its characteristic, which

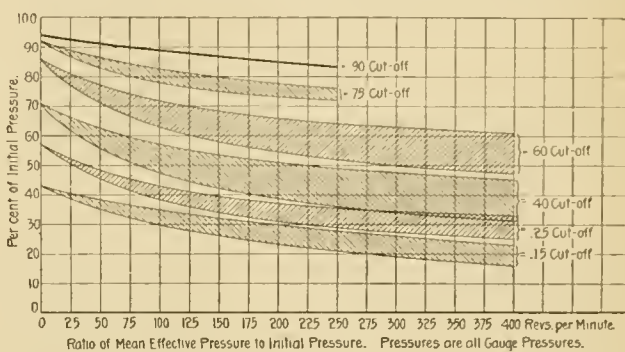

Fig. 3.

may be determined in advance even of its design, provided that the leading dimensions and proportions are given or assumed. While we believe this method of treatment to be original and somewhat radical, it may, we think, be used to good advantage in many cases, especially where the most economical conditions of operation are being studied.

HEATING FEED WATER WITH LIVE STEAM.

That it will pay to take live steam from a boiler to heat the feed water of the same boiler is very difficult for many to accept, but we may "believe one who has tried it."

"The Engineer" in reporting a recent meeting of the Institution of Naval Architects quotes Prof. Unwin as having found a saving of 15 per cent. in one case, by the use of live steam to heat feed water. For some time he was puzzled for an explanation of this apparent absurdity, but finally made up his mind that when water at boiling temperature comes into contact with the heating surface of a boiler it takes up heat more readily than cold water and in one case he found the temperature of the gases in the chimney to be reduced by a very hot feed, all other conditions of running remaining unchanged.

For many years it has been known that the transmission of heat through a receptacle containing boiling water was much more rapid than when the water was being raised to the boiling temperature and the reason appears to be found in the improved circulation on movement of the water.

Laboratory experiments are quoted by "Engineering" showing that where water is caused to move briskly over a heated surface, the rate of heating may be five times as great as when the water is left at rest and the further observation is made that the temperature of the water surface of a plate may be considerably more than that of the water nominally in contact with it, giving "the paradoxical result that this temperature may be less when the water is hot than when it is colder, provided that the circulation is more brisk with the hotter water." Mr. Macfarlane Gray, who has recently brought the subject into attention again, states that all of the heat that is transmitted through boiler plates should be put into the evaporation of the water and should not be used to raise it to the boiling point.

Whether this idea is new or old does not matter. It is very interesting and probably will play an important part in connection with steam engineering in the future. Some very progressive people are still a little skeptical and it can do no harm to urge that the subject be investigated very carefully. Those already using the principle will learn more about it and the skeptics may learn something also.

(Established 1832.)

AMERICAN ENGINEER

CAR BUILDER AND RAILROAD JOURNAL.

29TH YEAR.

67TH YEAR.

PUBLISHED MONTHLY

BY

R. M. VAN ARSDALE,

MORSE BUILDING..... NEW YORK

G. M. BASFORD, Editor.

JUNE, 1898.

Subscription.—\$2.00 a year for the United States and Canada; \$2.50 a year to Foreign Countries embraced in the Universal Postal Union.
Subscriptions for this paper will be received and copies kept for sale by the Post Office News Co., 217 Dearborn Street, Chicago, Ill.

EDITORIAL ANNOUNCEMENTS.

Advertisements.—Nothing will be inserted in this journal for pay, EXCEPT IN THE ADVERTISING PAGES. The reading pages will contain only such matter as we consider of interest to our readers.

Special Notice.—As the AMERICAN ENGINEER, CAR BUILDER AND RAILROAD JOURNAL is printed and ready for mailing on the last day of the month, correspondence, advertisements, etc., intended for insertion must be received not later than the 20th day of each month.

Contributions.—Articles relating to railway rolling stock construction and management and kindred topics, by those who are practically acquainted with these subjects, are specially desired. Also early notices of official changes, and additions of new equipment for the road or the shop, by purchase or construction.

To Subscribers.—The AMERICAN ENGINEER, CAR BUILDER AND RAILROAD JOURNAL is mailed regularly to every subscriber each month. Any subscriber who fails to receive his paper ought at once to notify the postmaster at the office of delivery, and in case the paper is not then obtained this office should be notified, so that the missing paper may be supplied. When a subscriber changes his address he ought to notify this office at once, so that the paper may be sent to the proper destination.

The paper may be obtained and subscriptions for it sent to the following agencies: Chicago, Post Office News Co., 217 Dearborn Street. London, Eng., Sampson Low, Marston & Co., Limited St. Dunstan's House, Fetter Lane. E. C.

The troublesome question of "wrong repairs," in the interchange of freight cars, has caused a great deal of discussion since the last convention and it now seems probable that the Master Car Builders' Association will take action to remedy the present difficulty with regard to neglect of the repair card. If intermediate roads are held responsible for the application of M. C. B. repair cards the trouble will be remedied because this will permit of locating the road making wrong repairs.

The narrow limits allowed by law for the height of couplers renders it necessary to provide convenient means for adjusting the height of cars after they have been placed in service. Several methods have been used, but one of the most convenient is that shown in the illustration of the new Lake Shore coal cars on another page of this issue. Wooden blocks are placed under the ends of the truck bolsters and above the springs. By varying the thickness of these the necessary adjustment may be made by simply raising the bolster off the springs.

It is not uncommon practice to increase the boiler capacity of old and comparatively small locomotives in rebuilding them

and besides adding to the heating surfaces and the grate area, the new boilers are often built for higher pressures, all of which increase their capacity for doing work. The remarks of Mr. F. R. F. Brown in regard to rebuilding locomotives, which will be found elsewhere in this issue, and also the ingenious, novel and valuable power comparisons made by Mr. G. R. Henderson in his article on "Locomotive Characteristics" tend to show the importance of large boiler capacity. Large boilers do not require as much forcing as small ones, for the same work, which may be expected to show favorably in the returns, but, as Mr. Henderson says, "The quantity of work done by a locomotive is of more importance than the economy of fuel shown by the same locomotive." High boiler power offers a double reward, an increased capacity for work and a more favorable rate cost for the work done. The numerical values for the increase in power with an increase in the vital dimensions and proportions which Mr. Henderson presents and the analysis of the locomotive by its characteristic before the construction is begun are full of interest and suggestions to locomotive men. The time is at hand for serious consideration of every possible factor contributing toward increasing the power of the locomotive and the analysis is commended as furnishing an "X-ray" view of the capabilities of an engine before it has been laid down even on paper.

LOCOMOTIVE TRUCK BRAKES.

The locomotive truck brake as an aid in stopping trains was the subject of discussion at the recent convention of the Air Brake Men's Association in Baltimore. This matter has been before the railroads for a long time and while the advantages obtained by the additional braking power are very great little progress has been made in applying them to engine trucks. There seems to have been no good reason why they have not been used more generally, unless the pressure brought to bear in connection with freight equipment has for a time caused a diversion of attention from these trucks. Mr. George Westinghouse six years ago directed attention to the fact that the locomotive, if fully braked, is capable of exerting four times the amount of retarding influence for each pound weight per wheel given by any other vehicle in the train with the exception of the tender, and in connection with this it is important to remember that the braking power of the locomotive does not vary with the loading, as is the case with cars. It is well that this subject should be kept in mind and after the requirements of the law in regard to car equipment have been fulfilled, the truck brakes will undoubtedly receive the consideration that is due them.

COMPETITIVE TESTS OF LOCOMOTIVES.

Some time before the Liverpool & Manchester Railroad was publicly opened, in 1830, the question of motive power naturally came before the directors, as it was then necessary to arrange to work the traffic on the road either by animal or some other kind of power. They employed eminent engineers to visit and inspect all the railways then at work, but from the reports which were made to the directors they did not feel able to come to a decision. It was, therefore, proposed to offer a reward, or premium, of £500 for the best locomotive engine which should draw a load equal to three times its weight at a given speed, and it was stipulated that the weight carried on four wheels of the engine should not exceed $4\frac{1}{2}$ tons=10,080 pounds, or 2,520 per wheel. The trial, we are told, "was to take place on a $1\frac{1}{2}$ miles stage, with one-eighth of a mile extra at each end for starting and stopping, and to consist of twenty double trips." "Each locomotive was required to run ten trips over the trial ground, equal to a journey of thirty-five miles, at full speed, the average rate to be not less than ten miles per hour. At the end of the first ten trips each engine was to be got ready again, and to repeat the test,

the object being to prove that the engine would be able to perform a journey from Liverpool to Manchester and back." Three historic locomotives were entered for the competitive test, the object of which, as stated, was to ascertain the best locomotive "to work the traffic" of the new line.

It often happens that the dictionary is very suggestive in indicating the force or scope of an idea. Now, one of the definitions of "competition" is "strife for superiority." It was the purpose, evidently, of the directors of this pioneer road to produce a "strife for superiority" among inventors, mechanics and engineers in the design and construction of locomotive engines. For the accomplishment of the end which they had in view, as was shown by subsequent events, it was essential that there should be competition. Stephenson adopted the multitubular boiler in his locomotive "Rocket," but we are told "after some preliminary trials, previous to the commencement of the competition, during which the superior evaporating power of the 'Sanspareil,' with a sharp blast from the exhaust directed upward into its chimney, became apparent, it was resolved to discharge the exhaust steam of the "Rocket" into the chimney; and, on the eve of the first day of the trial, the exhaust pipes were diverted into the chimney with an upward termination." It was this change, combined with the multitubular boiler, which enabled the "Rocket" to win the prize.

It was at this time of the utmost importance to the directors of this road that they should know what kind of motive power would be the most economical and efficient for the traffic of the line. This same question is of equal, and, in fact, considering the extent of the interests involved, of much greater, importance to the directors of our great railroads now than it was then. It is true that we have had sixty-eight years of experience in the construction of locomotives since then, in which time they have been developed from puny little asthmatic iron insects—they might be called—to mighty beasts whose tread literally shakes the earth, whose shrieks are echoed from mountain top to mountain top, and whose power is limited alone by the laws of nature. We have the precedents and practice of half a century or more to guide us in their construction, but even with this flood of light and knowledge there is still much difference of opinion among those most competent to be the mechanical guides, of boards of directors and railroad managers. In other words, the question which are the best locomotives? is as much a live one to-day as it was when the Liverpool & Manchester trial was proposed.

It is of course true that most railroads have and are making tests to ascertain which are the best, most economical and efficient locomotives for their traffic. Many of them employ experts who are possessed of varying amounts of knowledge and ignorance, and who subject locomotives to trials of different kinds. Some roads and educational institutions have testing laboratories especially adapted for making trials of locomotives, where the utmost refinement of experiment and observation is possible. The point to which special attention is called here is that in nearly or quite all such tests the competitive element is absent, and, what is perhaps worse, there is naturally and of necessity a bias of prejudice and interest to renege the conclusions drawn from true logical verity. A very common case may be cited. A locomotive superintendent designs and builds a locomotive, or prepares the specifications and decides upon the plans on which they shall be built. When completed, if he should test one or more of them, could we expect that he would report any serious deficiencies in such machines to his superior officers, no matter what the defects should be? It might be worse than that even, for under such conditions probably few men would be able to recognize any defects. During many years' intercourse with master-mechanics on railroads it was a very common experience of the writer to interview men in such positions who had built locomotives from their own designs. In nearly all such cases, when the new engine was exhibited to the interviewer the builder would proclaim, with uplifted arm, as though he was about to make

oath to the assertion, that "that is the best locomotive that ever turned a wheel," and they generally believed what they said. Now, under such conditions, if a master mechanic should test his engine is it at all likely that he would admit that its fire box was too small, its heating surface insufficient, that it had not enough steam space, and worked water, or its weight was improperly distributed. We all know he would not.

In their perplexity the directors of the Liverpool & Manchester railroad employed experts to indicate to the company what would be the most efficient motive power to employ. The most eminent of these engineers recommended that they should adopt rope traction. If they had not resorted to a competitive test the advice which they would have had to guide them would probably have been very much like that some of the superior officers of our railroads of to-day get from their experts, who spend months in figuring over the significance of vast multitudes of "variables" which are observed in highly scientific experimental tests of locomotives, on their own lines, in which there is usually "no strife for superiority."

Let us suppose a case: The traffic of a railroad has increased and an addition to the motive power is required. It will be supposed that at certain times of the year it has a heavy passenger traffic, which falls off materially—as it does on many lines—in midwinter, and at other times. It is essential that engines for this traffic should be able to pull heavy loads at some seasons, and that they should work economically when the trains are lighter. Now, supposing that under these conditions a railroad company was about to order, say ten new engines, and the question should arise, what kind would be best suited for the requirements of such traffic, what would be the natural course of the inquiry? The condition and character of the road bed and rails would limit the loads which should be carried per wheel, as it did on the Liverpool & Manchester road. On a well ballasted line laid with heavy rails, it is now considered admissible to load each of the driving wheels with 20,000 pounds. If four wheels thus loaded would give sufficient adhesion and traction to pull the heaviest trains, then the general plan which would probably be specified, would be either the American, Columbia or Atlantic type of engine, the weight of which would be limited to about 120,000 pounds each. Those in authority would then want to know first the relative first cost of engines of such a weight of the several plans; second, which would haul the trains with the greatest regularity and promptness and the least consumption of fuel and lowest cost of repairs; and, third, which would perform the maximum amount of service in a given time, say a year, or a number of years. Evidently this was the sort of information the directors of the Liverpool & Manchester railroad were after, and it is the kind of knowledge about locomotives that general officers and directors want now when they are about to increase their motive power. The quantity of water evaporated per pound of coal, the temperature in the smoke box, the precise form of indicator diagrams, which the engine will make, or its consumption of fuel per horse power per hour are all matters of indifference to them. What they want most to know is which kind of engine is most certain to pull the trains on time from day to day and year to year, and next—but this is of secondary importance—which will do it with the least cost of fuel and expense for maintenance? Of course it is true that the reliability of a locomotive can only be demonstrated by actual service, but the relative reliability of several classes could be very clearly indicated by a competitive test.

The point which it is intended to bring out here is that a test which is not competitive proves very little. If an American locomotive runs on the A. & B. road and one of the Columbia type on the C. & D. line, it is usually impossible to tell which would have rendered the best service if each had been tried on the same line. There is also another phase of what may be called *ex parte* tests, and that is that it is almost impossible to prevent those who are in charge of the experiments from showing undue favoritism to the engines tested. Many employees consider it their duty to lie and cheat in their em-

ployers' interest. Most sporting men would regard with derision an attempt to determine which of a number of horses was the fastest by a trial of speed of each separately and on different tracks. And yet that is what is done when we undertake to determine the speed and endurance of locomotives.

What is suggested here then is that competitive tests of locomotives should be made under the auspices and direction of a committee of the Master Mechanics' Association, the main object of such tests being, as mentioned before, to ascertain what kind of locomotive is the best adapted for a certain kind of traffic.

The course of procedure and the aims of such a movement would be, first, to have a committee of say five members of that association to formulate a plan of making the tests and have charge of and direct how they should be made. The committee should consist of several members of the hard-headed, practical type, who have had long experience in their occupations, and two who, besides ample experience, have had the advantages which technical educations give them, and perhaps an experienced designer of locomotives. Now, as such men would in all probability be actively engaged in the performance of their duties on different railroads, it could not be expected that they could give the time required to personally conduct a series of experiments which, in all probability, would occupy weeks or months. The committee would therefore require to employ some competent person to take charge of the experimental work, and he would need an assistant. The committee would, however, after the most careful deliberation, determine the scope and nature of the investigations, and specify in detail how they should be made. The person or persons employed would act under the direction of the committee, and would report to the latter. As probably no competent person could be found to take charge of such work who would be willing to give the time to them which would be required without compensation the mechanical expert and his assistant would have to be paid. This would imply that some money must be provided for such, and some few other expenses. The committee should therefore be authorized to raise and expend money for the purpose contemplated, with the usual powers and responsibilities of an auditing committee.

Some years ago a somewhat similar measure was proposed and acted upon by the Master Mechanics' Association, and one committee was then appointed to solicit and raise money and then hand it over to another committee—over which the first one had no control—to expend. Some of the members of the ways and means committee very properly objected to incurring the responsibility of soliciting money without authority to control its disbursement. The persons who secure the money for such tests should have the control and the responsibility for its expenditure.

The investigations, in the beginning, should be directed to the solution of some very practical problems alone, and should be devised to indicate simply which of a number of locomotives will perform a given service most effectually and at the least cost. The tests should therefore be made in actual service. The method of making them may be suggested:

An arrangement could doubtless be made with some road having a somewhat uniform traffic to haul one of its trains, such as an express passenger train, consisting of say five or six cars daily, over its road on schedule time, with the engines to be tested. Each one would make one or two round trips with the train of normal size. Cars would then be added to it on successive trips, until the train reached the maximum weight which each engine could haul on schedule time. A half dozen trips would probably be sufficient for each engine, but if a storm or other serious disturbance to the working of the engine was encountered which was not its own fault the test for that day could be declared void and the trip would be repeated. The fuel consumed during each run would be carefully weighed, and an exact record kept of it, and the weight of the trains hauled each trip and the time of arrival and de-

parture from stations. These would be about all the observations which would be essential to make, excepting perhaps to note the weather and the number of passengers carried. One trip should be made over the road on schedule time with the engine and tender alone, without any train, as the consumption of fuel under these conditions is sometimes very significant in indicating the inefficiency and defects of a locomotive.

If the committee should choose for trial only the best examples of locomotives adapted for the service selected, there would be little more risk of interference with the regular running of the trains on the line where the tests are made than there would be if the ordinary locomotives of the line were used. The rule should, however, be laid down by the committee that no locomotive belonging to the road on which the experiments are made should be tested there. In other words, no home locomotive should be allowed to compete with strangers on its own road. The reason for this is obvious, as favoritism would be certain to be shown to it by the members of the family at home.

Of course the above is only the merest outline and suggestion of the conditions which should govern such a trial. Doubtless a committee in conference would see directions in which such conditions would require extension and elaboration, but what is insisted on here is that the test should be a competitive one between different locomotives, all on a foreign road, to show practically which is best adapted and most efficient in a certain kind of traffic. More scientific investigation and analysis might be desirable later, to ascertain the causes of some of the phenomena revealed by the tests.

Suppose, now, that the committee should stipulate that only four-coupled locomotives should be tested in the first series of trials, and that the weight of those to be tested must not exceed 122,000 pounds, or be less than 118,000 pounds, in working order. Perhaps no other limitation would require to be made excepting perhaps that the weight on any pair of wheels must not exceed 41,000 pounds or less than 39,000 pounds. The builder should be permitted to make his engine of any form and proportions that he might choose, the only stipulation being that the combination of metal, wood, water and fuel must be within these limits of weight. The locomotives might be either compound or simple, and have two, three or four cylinders, single or double smokestacks, as the designer might prefer, the problem for solution being what combination of material of that weight will form the most efficient locomotive for the kind of traffic stipulated.

Supposing now that three approved simple locomotives of the American, one of the Columbia and one of the Atlantic type and one or two compound engines were selected for trial, and a record was kept of the performance of each. The work would be done on the same road, on the same schedule time, and as nearly as possible under like conditions, and no engine would be nursed by its friends, excepting so far as the skill of the men who run it could bring out its best performance. The comparison of such a record would be quite sure to indicate clearly which of the engines was the best for the service in which they were employed, and a knowledge of the results might be of incalculable advantage to the railroad companies of the country.

If the locomotives to be tested and the men to run them were furnished free of cost by their builders, and the railroad company on whose line the tests were made would supply the fuel, there would be but little expense in making such an investigation, excepting the pay and expenses of the persons in charge of them and perhaps some cost for labor and appliances in weighing coal. Some extra cars would have to be supplied to increase the train loads in some of the runs, but this would involve no outlay of money.

In view of the value of the knowledge which would be likely to be elicited by such experimentation it seems as though there ought not to be any difficulty in raising the comparatively small sum of money required to pay the cost of making such tests.

THE BREAKING IN TWO OF FREIGHT TRAINS.

Since the topical discussion on this subject at the convention of the Master Car Builders' Association in 1897, a great deal of attention has been given to the part which the couplers play in these accidents, and the committee report last year, also treats of this side of the question. During the year it has developed that there are several influences besides those connected with couplers which need investigation and attention by the association.

Among the causes for the parting of trains the following may be mentioned: Defective designs of couplers, which permit the locks to work open on the road, due to the oscillation of the cars; defective uncoupling devices, which are too short in the connections and cause the locks to be lifted when the couplers are drawn out by heavy pulls; swaying of the train on account of variable braking power among the cars, due to defective adjustment of slack; surging in the train on account of sluggish triple valves that have not been inspected and cleaned often enough, and last and probably most important of all is the parting that is due to the methods of handling the brakes on trains that are only partially equipped with air brakes. Closely allied to the last cause is the matter of arrangement of the cars, in partially air braked trains, which should be such that the effects of the cars upon each other shall be as small as possible.

The brakes have much to do with break-in-twos. The equipment of cars with air brakes is progressing very rapidly, and it is believed that when trains are made up of all air braked cars, much of the trouble will stop, providing the necessary improvements in couplers and their unlocking devices are made. The best solution of the partially equipped train, therefore, is to equip all cars as rapidly as possible. In the meantime, how to handle partially equipped trains, and how to arrange the air braked cars in trains, are questions upon which there are wide differences of opinion.

The question of how to handle the slack between the cars has been given special prominence by a paper by Mr. C. L. Nichols of the Chicago, Rock Island & Pacific, read last August before the Central Association of Railroad Officers. (See Railroad Gazette, Oct. 22, 1897, page 739.) Briefly stated the use of a few hand brakes at the rear of the train is advocated, the air braked cars being placed next to the engine, and Mr. Nichols' rules require the trainmen, at every stop, to treat the train as if it were broken in two. The rear brakes are used to stretch out the slack before the application of the air brakes by the engineman. Figures from the records of the road appear to support the plan, but it is so entirely contrary to what many good authorities recommend as to warrant skepticism, and one authority goes so far as to say that he does not believe the Rock Island men obey the rules.

While the profile of the road has much to do with the use of the brakes the bunching of the train by light application of the air brake by the engineman has the indorsement of best practice, and it will require the strongest of reasons to induce general use of any other method. If hand brakes are to be used in the bunching of the train, they would probably be most effective if applied at the head of the non air brake cars. The air brakes may then be operated in harmony with the hand brakes better than those at the rear of the train. The proportion of air braked cars is now generally about one-third of the number in each train, which is enough to control the train as far as retarding power is concerned, and the use of the hand brakes, if they are to be used at all, should be to assist the engineman in avoiding the parting of the train. The best authorities on the air brake advise the shutting off of the engine far enough back to permit the slack to "run in" as far as possible, this to be followed by the application of the minimum amount of air that will insure driving the pistons past the leakage grooves, and after this such further reductions as may be necessary, making, however, but one application of the air brakes, and avoiding the release of the

brakes on a long train until the train has stopped. Particular stress is laid upon the fact that the slower the train is moving the more likely it is to part, and this is supported by the figures given in the committee report at the 1897 Master Car Builders' convention. It is a good plan to hold the train "by the tail" after it has broken in two, but brakes at the rear may be expected to cause them to break.

It is customary to place the air brake cars at the head end of the train, and loaded cars usually precede unloaded ones, while the non air brake cars are put at the rear. Mr. Edward Grafstrom presents a strong argument (see Engineering News, December 23, 1897, page 411) for placing the empty air brake cars next the engine, followed by loaded air brake cars, while the non air brake cars bring up the rear. He reasons that a non air brake car retarded only by the friction of the journals will produce more impact upon an empty air brake car than upon a loaded one, because the difference between the velocity of the non air brake car and the empty air brake car is greater than that between the non air brake car and the loaded air brake car. He believes that when empty air brake cars precede loaded ones, and these are followed by non air brake cars, the latter, when the brakes are applied, will gradually give up their energy to the loaded air brake cars successively, and at the same time the empty air brake cars in front have begun to take up the energy of the foremost loaded air brake cars, and that by the time the non air brake cars and the loaded air brake cars have been brought to the same velocity, the latter and the empty air brake cars have also been brought to the same velocity. On the other hand, when the usual arrangement of empty air brake cars between loaded air brake cars and unbraked ones obtains, when the brakes go on the loaded air brake cars will jerk the first empty air brake cars forward, while the next moment the unbraked cars will be brought up sharply against the rear of the empty air brake cars, which are then stretched out with slack between them. This argument is worthy of careful attention.

It is an easy question to settle by experiments upon different arrangements of the cars in the same train and the relative amounts of shock obtained might be recorded by "slideometers" placed at several points along the length of the train. It would cost so little we should think the association would find it profitable to investigate thoroughly. It seems probable that this arrangement of cars might work desirably in ordinary service application of the brakes, but it would surely be a good thing in making emergency stops. Summing up, we should say that:

Couplers should be made so that they will not open accidentally, triple valves should be cleaned at regular intervals, at least once a year; automatic brake slack adjusters should be applied as rapidly as possible, the best method of handling partially air braked trains, and the best arrangement of cars should be studied, but the best solution of all for this difficulty of trains parting is to put air brakes on every car at the earliest possible moment. They will tend to reduce break-in-twos and will reduce the dangers from those that they do not prevent.

A plan for rewarding conscientious efforts to do good work on the part of enginemen, firemen and brakemen in freight service has been adopted on the Cincinnati, New Orleans & Texas Pacific Railway, in the form of semi-annual premiums. The premium for enginemen is \$40 and for firemen \$20, for making schedule time, freedom from accidents, particular stress being laid upon accidents from break-in-twos, tidiness of the engine, and economy in fuel consumption, obedience of the rules and specially meritorious acts. The premium for brakemen is \$20, and is based on clean accident record, speciality regarding break-in-twos, tidiness of caboose, observance of rules, and specially meritorious acts. Any system providing prompt, material and unprejudiced reward for efforts to serve employers well must result favorably. The administration of a system of this kind requires the utmost skill and fairness. It is believed to be based on a correct principle in human nature, and the plan must commend itself to every one, but without the element of scrupulous justice it had better not be tried.

LOCOMOTIVE DESIGN—THE WORKING STRESS OF MATERIALS.

By Francis J. Cole.

Driving Axles.

It is safe to assume that the determination of the size of locomotive driving axles is governed in nine cases out of ten by the area of the bearing surfaces alone. For a given load to be borne on each journal, a certain number of square inches of bearing surface is provided and the pressure kept within such limits as experience has demonstrated to insure cool running and freedom from excessive wear. Some idea then of the limitations of the pressure it is advisable to use seems necessary. The maximum is in the neighborhood of 220 pounds per square inch, the net weight resting on the journals, exclusive of the driving wheels and axles, being con-

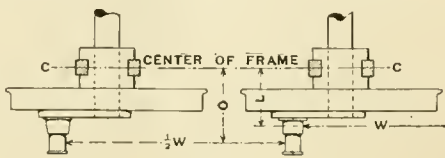

Fig. 1.

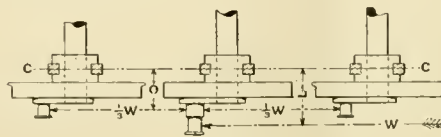

Fig. 2.

sidered as the load. The minimum is noted at 130 pounds. This does not mean the lowest ever built, but a lower limit, under which it does not seem advisable to go, in order to guard against excessive size and clumsiness. A pressure of 175 pounds is suggested as suitable for ordinary conditions. When axles and bearings of exceptional wearing qualities are used a somewhat higher pressure could perhaps be allowed, and for inferior materials a somewhat lower pressure might be advantageous, but for ordinary "every day" conditions the figure named would be found satisfactory.

There is, however, another side of the question to be considered: It is possible to provide ample bearing surface and yet have an axle greatly overstrained. A journal 7 in. in dia. by 12 in. long has a bearing surface of 84 square inches, but its strength is much inferior to one 8 in. dia. by 10½ in. having a bearing surface of 85 square inches; the section modulus

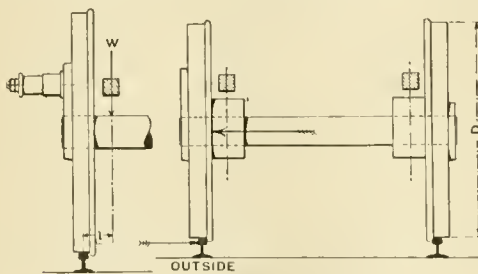

Fig. 3.

Fig. 4.

of the former would be 33.68 and the of the latter 50.27, while both have about the same capacity for wear. The distance from the center of the frame to center of the cylinder may be much greater in one case than the other, while the journal weight would remain the same. Yet the stress in the case of the greater distance would be increased directly as the distance. The stresses in driving axles are:

(a) The bending stress caused by the piston thrust or pull transmitted through the main connecting rod to the crank pins, and resisted by the driving box held rigidly in the jaws of the engine frames. (b) The bending stress caused by the weight of the engine carried on the axle acting at right angles to (a). (c) The torsional stress caused by the unequal adhesion of the wheels. (d) The bending stress caused by the centrifugal force when rounding a curve resisted by the flanges of the wheels. The principal stress is that caused by the force of the piston, shown in Fig. 1.

The extreme fiber stress for a solid circular section fixed at one end with a single load at the other:

$$S = \frac{W L}{\left(\frac{\pi d^3}{32}\right)} \text{ reducing to } \frac{W L}{0.0982 d^3}$$

In Fig. 1 an eight wheel engine of the American type is shown, having two pairs of coupled wheels and the main rod next the wheel hub, in which:

W=force of the piston.

L=center of main rod to center of frame.

O=center of parallel rod to center of frame.

C. C.=center of main frame.

M=bending moment.

R=section modulus for solid circular sections = $\frac{\pi d^3}{32}$ reducing to 0.0982 d³.

S=maximum fibre stress per square inch. Then for the main axle the bending stress per square inch will be:

$$S = \frac{\frac{1}{2} W L}{R}$$

For the back axle the bending stress per square inch will be:

$$S = \frac{\frac{1}{2} W O}{R}$$

Taking the following assumed values: Diameter of cylinder = 20 inches; pressure of steam = 180 pounds; L = 15 inches; O = 20 inches; diameter of axle, 8 inches; limit of wear 7½ inches.

Then for the main axle:

$$\text{New axle 8 inches diameter} = S = \frac{.5 \times 56520 \times 15}{50.27} = 8430.$$

$$\text{Worn out axle 7½ in. diameter} = S = \frac{.5 \times 56520 \times 15}{41.34} = 10250.$$

For the back axle:

$$\text{New axle 8 in. diameter } S = \frac{.5 \times 56520 \times 20}{50.27} = 11240.$$

$$\text{Worn out axle 7½ in. diameter } S = \frac{.5 \times 56520 \times 20}{41.34} = 13,670.$$

For a Mogul or 10 wheel engine, having the main connecting rod outside the parallel rod, the conditions will be as shown in Fig. 2. For the main axle the bending stress per square inch will be:

$$S = \frac{\frac{1}{3} W L}{R}$$

For the back and front axles the stress per square inch will be:

$$S = \frac{\frac{1}{2} W O}{R}$$

For a consolidation engine the bending stress per square inch for the main axle will be:

$$S = \frac{\frac{1}{4} W L}{R}$$

For the front, back and intermediate axles the bending stresses will be:

$$S = \frac{\frac{1}{4} W O}{R}$$

The decrease of the diameter of the axle, caused by the journal wear, must always be considered. The worn out size should be used as the basis for the calculation. If an axle is 8 in. in diameter when new, and the limit of wear is 7½ in., use

the latter diameter for figuring the effective strength, and not the primary size. The life of an axle should be limited only by the allowable journal wear, and not from any empirical rule, based on its mileage, provided, however, that it is originally of suitable proportion to keep the stresses within reasonable limits. Otherwise it might be necessary, when the axle was overstrained, to proceed on the assumption that it might break after a few million repetitions of the load, and remove it before a possible failure took place. The stress due to the dead load is caused by the weight resting on the driving box multiplied by the distance from the center of the engine frame (or, what is the same thing, the center of driving box) to the center of the rail, as in Fig. 3, in which:

W=load on each journal.

l=lever arm, center of box to center of rail in inches.

R=modulus of section of axle when worn out.

Then:

$$S = \frac{Wl}{R}$$

The torsional stress is caused by the turning moment of one crank when at or near half stroke, and consequently at its maximum force (the turning moment of the opposite crank being then at zero), exceeding the adhesion of its own wheel, or when, on slippery parts of the rail, a portion of the force is transmitted by the axle, to the opposite wheel. It is not probable that under any circumstances could more than half the turning moment be transmitted by the axle to the opposite side. Using the well known formula for torsional stress, in which

S=maximum shearing fibre stress per square inch.

W=force or weight.

L=lever arm.

R=modulus of section of axle when worn out.

$$S = \frac{2 W L}{\pi r^3}. \quad \text{But in this case it is more convenient to use}$$

R the modulus of section instead of the expression πr^3 (the cube of the radius, multiplied by 3.1416) and making the proper substitution $S = \frac{\frac{1}{2} W L}{R}$.

The stress due to centrifugal force is caused by the engine passing around a curve, the mass being diverted from moving in a straight line by the flanges of the wheels pressing against the outer rail. The well known formula for centrifugal force will enable us to determine the pressure against the rail, for any given weight, radius of curve and velocity; the resultant bending stress on the axle can then be easily calculated.

$$\text{Cent. F} = \frac{W v^2}{g r} \text{ in which:}$$

F=centrifugal force in pounds.

W=weight in pounds of the moving mass of one pair of wheels resting on the rails.

g=gravity 32.2 lbs.

r=radius of curve.

v=velocity in feet per second.

The centrifugal force for each pound of weight for a few different radii of curves and speeds in miles per hour are given:

$$10^\circ \text{ curve, speed 60 miles} = \frac{v^2}{r g} = \frac{7744}{573 \times 32.2} = .419 \text{ per lb.}$$

$$10^\circ \text{ curve, speed 40 miles per hour} = .186 \text{ per lb.}$$

$$6^\circ \text{ curve, speed 60 miles per hour} = .251 \text{ per lb.}$$

Probably the latter is the greatest flange pressure due to the centrifugal force for which provision need be made.

The bending stress at the axle will cause the upper fibres to be in tension and the lower in compression, or directly opposite to and partly or wholly neutralizing at times that due to the dead load, as in Fig. 4:

$$S = \frac{F W (\frac{1}{2} D)}{R} \text{ in which:}$$

F=centrifugal force.

D=diameter of wheel.

The foregoing is based on the supposition that the curves have no elevation of the outer rail, and that all the centrifugal force is resisted by the wheel flanges, but as all curves on the main track have some elevation of the outer rail it is manifest that a part of this force is absorbed by the inclination of the track and that something less than these figures must be taken. Theoretically, for a given radius and speed it is possible to give the proper inclination to the track suitable for these conditions with such a degree of refinement that there would be no flange pressure on the outer rail, but all would be resolved instead into a force acting perpendicularly to the rails. In practice, however, this cannot be done, the elevation being a compromise between fast and slow trains, so that at high speeds much of the centrifugal force is transformed into flange pressure. The proper theoretical elevation of the outer rail can be calculated by means of the following formula:

$$E = \frac{d v^2}{32.2 r} \text{ in which:}$$

E=elevation required.

d=distance between center of rails.

v=velocity in feet per second.

r=radius of curve in feet.

It is evident that the sum of the various stresses will not be the actual maximum fibre stress at any one part of the axle, as they act in different planes and directions and must be combined in order to obtain the correct resultant at a given point. The crank pin pressure produces bending in the axle at right angles to that produced by the dead load, or by the centrifugal force producing pressure against the flanges.

Let C=bending stress from crank pin pressure.

Let D=bending stress from dead load.

Let S=resultant or combined stress. Then:

$$S = \sqrt{C^2 + D^2}$$

Graphically, the resultant is equal to the hypotenuse of a right angled triangle, in which the length of one side is equal to C and the other side to D, as in Fig. 5. To combine the re-

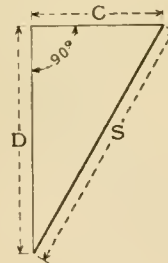

Fig. 5.

sultant stress obtained by the combination of the crank pin and the dead load stress with the torsional stress:

Let T=torsional stress.

Let S=combined bending stress.

Let Y=resultant.

$$\text{Then } Y = \frac{S}{2} + \sqrt{\frac{S^2}{4} + T^2}$$

Probably one-half the torsional stress is all which should be used. The calculations in detail of a mogul locomotive is given below:

Cylinders, 19x26 in. Steam pressure, 180 pounds per square inch. Diameter of axle, 8 in., minimum size assumed to be 7½ in. Diameter of driving wheel, 56 in.

L=19½". See Fig. 2.

O=14". See Fig. 2.

W=50940.

R=section modulus.

Bending moment for main axle (when worn to 7½ in.) due to force of piston:

$$S = \frac{\frac{1}{3} W l}{R} = 8010.$$

Bending moment for main axle due to dead load:

W=14500,
Z=6".

$$S = \frac{W l}{R} = 2100.$$

For the torsional stress, the force of the piston is divided equally between the driving axles (in this instance there are three axles); therefore:

$$S = \frac{16 W l}{\pi d^2 3} \text{ or } \frac{2 W l}{\pi r^2 3} \text{ or } \frac{\frac{1}{3} W l}{R 3}$$

and using the latter

$$M = \frac{\frac{1}{3} W l}{3} = \frac{25470 \times 13}{3} = 110370$$

$$S = \frac{M_r}{R} = \frac{110376}{41.34} = 2670 \text{ pounds.}$$

Assuming that one-half of this is the maximum torsional stress likely to occur at any time we have $\frac{2670}{2} = 1335$ pounds.

For the bending moment due to centrifugal force, the weight resting on the rail of one pair of drivers=36500. Curve 6°=955 feet radius. Speed 50 miles per hour=73.3 feet per second.

$$\text{Cent. F} = \frac{W v^2}{g r} = \frac{36500 \times 5373}{32.2 \times 955} = 6370. \text{ Lever arm} = \frac{1}{2}$$

diameter of driving wheel $\frac{56}{2} = 28$.

$$S = \frac{F (\frac{1}{2} D)}{R} = \frac{6370 \times 28}{41.34} = 4310 \text{ pounds.}$$

Probably the flange pressure would not exceed one-half of the total centrifugal force, the remainder being absorbed by the elevation of the outer rail $\frac{4310}{2} = 2155$ pounds, or very slightly in excess (55 lbs.) of the dead load which it neutral-

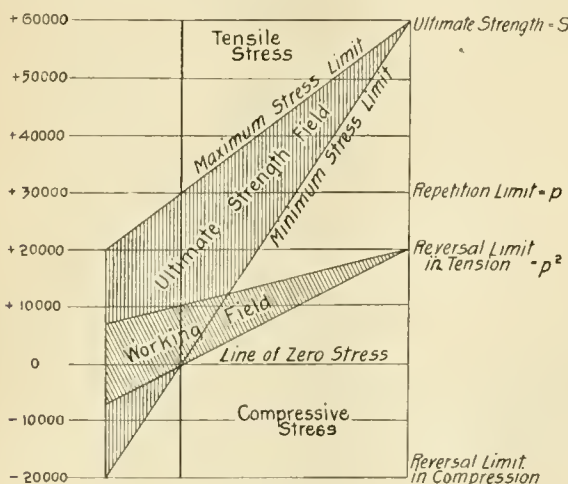

Fig. 6.

izes. Where the diameter of the wheel is so large that the stress due to the centrifugal force is much greater than that due to the dead load stress, it should be used in its place.

Combining the crank pin and the dead load stresses:

$$S = \sqrt{C^2 + D^2} = \sqrt{8010^2 + 2100^2} = 8280.$$

Combining the above resultant with the torsional stress, taking the latter at one-half

$$Y = \frac{S}{2} + \sqrt{\frac{S^2}{4} + T^2} = \frac{8280}{2} + \sqrt{\frac{8280^2}{4} + 1335^2} = 8490$$

pounds maximum fibre stress when the main axle is worn down to 7½ inches diameter.

Actual breakages of driving axles confirm the statement that the main axles on freight engines, (main rod outside the parallel rods) and the back axles on passenger engines, (main rod inside), are subjected to much higher stresses than the other axles. The majority of breakages will be found to occur in the axles named, when the diameters are the same for all the driving axles under the same engine. For freight engines the main axle is sometimes made larger in diameter than the others. If it is desirable to make the engine as light as possible this is a good plan, otherwise it is better to make them all alike, basing the size on the requirements of the main axles. The following table gives the maximum stresses (figured on the diameter when worn out) which are suggested for different types of engines:

	Ham. Iron.	Steel.
Consolidation	7,500	8,500
Ten-wheel and mogul	8,500	9,500
Passenger 8-wheel.....	10,500	13,000

The steel is assumed to be first-class open hearth steel of not less than 80,000 lbs. tensile strength, with an elongation of not less than 18 per cent. in two inches, and phosphorus not above 0.05.

Modulus of Solid Circular Sections.

$$R = \frac{\pi d^3}{32} = .0982 d^3.$$

Dia.	M. of S.	Dia.	M. of S.	Dia.	M. of S.	Dia.	M. of S.	Dia.	M. of S.
1	.098	3	2.65	5	12.27	7	33.68	9	71.58
1¼	.139	3¼	2.99	5¼	13.27	7¼	35.52	9¼	74.52
1½	.191	3½	3.37	5½	14.21	7½	37.31	9½	77.71
1¾	.255	3¾	3.77	5¾	15.25	7¾	39.38	9¾	80.90
1⅞	.331	3⅞	4.20	5⅞	16.33	7⅞	41.34	9⅞	84.18
2	.421	4	4.67	6	17.47	8	43.53	10	87.55
2¼	.526	4¼	5.18	6¼	18.66	8¼	45.71	10¼	90.91
2½	.647	4½	5.71	6½	19.90	8½	47.95	10½	94.55
2¾	.785	4¾	6.28	6¾	21.21	8¾	50.27	10¾	98.20
3	.942	5	6.89	7	22.56	9	52.70	11	101.9
3¼	1.12	5¼	7.53	7¼	23.96	9¼	55.14	11¼	105.7
3½	1.31	5½	8.22	7½	25.43	9½	57.63	11½	109.6
3¾	1.53	5¾	8.94	7¾	26.96	9¾	60.30	11¾	113.6
4	1.77	6	9.71	8	28.55	10	63.00	12	117.8
4¼	2.04	6¼	10.53	8¼	30.00	10¼	65.78	12¼	122.0
4½	2.33	6½	11.37	8½	31.91	10½	68.64	12½	126.3

Driving axles almost invariably break close up against the inside of the wheel hub and not in the center of the journals, where the figured maximum bending stress occurs, assuming an axle of uniform diameter. This is due to three causes: (a) The concentration of the bendings and vibrations at the rigid wheel center. (b) The common practice of reducing the diameter of the wheel fit ⅛ to ¼ inch below the size of the journal. (c) The loss of strength caused by cutting the keyway in the wheel fit on the side next to the crank pin. This reduces the strength on the side which is subjected to the greatest stress.

In a general way it seems to be a fact that as the number of pairs of driving wheels increase, the stress should be decreased. This seems plausible, too, when it is remembered that any variation in the adhesion of the drivers increases the stress on some of the axles, the force not being equally divided; also, that the adjustment of the parallel rods may be such, that the thrust of the main rod is not evenly distributed between all the wheels, the main pair having to withstand the excess up to its limit of adhesion, on possibly at times, a well sanded rail. On freight engines the range of stress is greater than on passenger engines, as the steam pressure is not so much reduced towards the end of the stroke, the point of cut off being usually much longer in freight service. The initial pressure in the cylinders at the commencement of the stroke approaches at times nearly to boiler pressure and is prolonged or reduced according to the speed and point of cut off, so that the full force is applied to the pin at the beginning of the stroke in one direction and at the end of the stroke, or nearly at the end, when the pin has turned over (presenting its other side), part of the force is applied in the opposite direction. The stress is, therefore, alternating, the pressure at the ter-

mination of the stroke being the minus amount, or the reversal load below the zero line.

The relations existing between the three general methods of loading are summed up by a well known authority as follows: Unwin reasons from the result of Wohler's experiments, "that a real factor of safety can be used between the working and the breaking stress. For ductile iron and steel the ultimate strength, or the stress at which fractures will take place, when repeated an infinite number of times is:

Static or dead load=the ultimate strength=1.00,
Load applied and entirely removed=.6 ultimate strength=.60.

$$\text{Alternating load} = \frac{\text{ultimate strength}}{3} = .33.$$

"These figures can be taken as actually representing the ultimate strength of the material under three general methods of loading. The working stress should be based on these calculations."

J. B. Johnson in "Materials of Construction" shows graphically the working field for the different methods and degrees of loading, summing up all the reliable data on hand regarding the fatigue of metals from the experiments of Wohler, Bauschinger, U. S. Arsenal at Watertown, as in Fig. 6:

Static load limit=S=ultimate strength.
Repetition limit=p₁=½ ultimate strength.
Reversal limit=p₂=¼ ultimate strength.

When the ultimate limits are reduced to working limits p₁ is supposed to reduce to a then:

Working static-load stress=2a.
Working live-load stress=a.
Working reversed stress=¾a

Let p=maximum stress in the member per square inch for both dead and live loads.

Let a=working stress for live loads.

$$p = \frac{a}{1 - \frac{2 \text{ maximum stress}}{\text{minimum stress}}}$$

The necessity for a lower stress, when an alternating load is to be resisted, is therefore apparent. The writer is firmly of the opinion that nearly all the failures of steel axles, when of suitable proportions, have been caused by the use of improper grades of steel. Because Bessemer steel is a suitable material for rails, it does not necessarily follow that it is desirable for axles, and superior and more durable than hammered iron. Nor does it follow that soft or mild steel, of say 55,000 to 65,000 lbs. tensile strength, which is so reliable and tough (its use being so satisfactory for boilers, plates, shapes, etc.), should prove a suitable material when good bearing surfaces and freedom from breakage are required. Mild steel for some years has been regarded by many very much in the light of a patent medicine which could be used for all purposes and guaranteed to be a universal panacea. It may seem unnecessary to some who have outgrown this belief, to again call attention to the fact that mild steel is not a suitable material for axles. It is advisable to specify exactly what is wanted when material for this purpose is required, and to test it afterwards to see whether the conditions have been complied with, or to purchase of some reliable dealer, whose reputation and price are at once a guarantee of its quality and suitability for the purpose. Steel of a high tensile strength and elastic limit, with enough elongation to insure its toughness and ductility, made by the open hearth process, of say 80,000 to 90,000 lbs. tensile strength, with an elongation of 22 per cent. in 2 inches, and phosphorus not over 0.05 per cent., when thoroughly worked and well hammered, is an entirely reliable material and superior in every respect to wrought iron or mild steel. It is a matter of observation that its use is becoming more general every day. This grade of steel is still further improved by various methods of tempering or annealing, in which the forging strains are neutralized and by the addition of nickel in small quantities. The conclusions are:

That driving axles should be first designed to afford sufficient bearing surface to insure cool running, the proportion being about 1 square inch to 175 lbs. of net load, and secondly, for the known forces which give rise to stresses in the metal, keeping the fiber stress within safe limits.

By far the greatest bending stress is due to the direct thrust of the piston, the stresses from other causes being comparatively insignificant in comparison.

The greatest stress is on the main axle in freight engines and on the back axle in passenger engines.

When it is advisable to reduce the bending moment, the spread of the cylinders should be made as small, and that of the engine frames as great as practicable.

That hard steel having a high elastic limit and suitable ductility, possesses the properties of being a good bearing material and capable of resisting severe shocks, is well adapted for axles.

WINANS' CAMEL ENGINES.

By M. N. Forney.

The Baltimore & Ohio Railroad, as most readers know, was one of the pioneer railroads in this country, and its shops in Baltimore were commenced away back in the early thirties, and ever since have been located at Mount Clare, and some of us old fellows can remember queer things, which could be seen here away back in the fifties. Until within a few years ago there were still some of the old grass-hopper engines, with vertical boilers and vertical cylinders, at work about these shops, switching cars on the crooked tracks and sharp curves, of which there were then and are still so many at Mount Clare. Some of these locomotives were in continuous service for over fifty years, a record which probably cannot be equalled by any other locomotives in the world. They have now all gone into the scrap-pile, excepting the one preserved in the Field Columbian Museum in Chicago.

Another type of locomotives used more extensively, and retained longer in the Baltimore & Ohio Railroad than on any other line, were the Winans' camel engines. Only three specimens of these remain. Two of them, battered and worn, and much altered from their original design, were standing on a side track at the time the observations here recorded were made, and the fiat had gone forth that they should be cut up and destroyed. There is but one more on the road, and that, too, will doubtless soon follow its predecessors, and then this type of locomotive will be as extinct as the dodo. It is very much to be regretted that no complete drawings of these engines are now in existence, and owing to the alterations which have been made in them it would be impossible to reproduce them accurately now. Very soon even the recollection of them, which still remains in the minds of some of us who are left, will also be gone, and the future writer of the history of the locomotive, like some of his predecessors, will be obliged to do a great deal of guessing.

Some description of these locomotives may now be interesting to the younger readers of the American Engineer. The outline engraving of the camel engine, Fig. 1, which is given herewith, has been made from an old lithograph which was issued in 1852, as an advertisement by Ross Winans, who was the designer and builder of these engines. Many of the minor details were omitted in this lithograph, but all that is shown on it is approximately correct. The title on it is

TRANSPORTATION ENGINE,

ADAPTED FOR THE BURNING OF ANTHRACITE OR BITUMINOUS COAL.

MANUFACTURED BY
ROSS WINANS,
BALTIMORE, MD.

The following "remarks" are inscribed on one corner of the lithograph:

Weight of engine with coal and water.....	24 tons.
Diameter of boiler.....	46 inches.
103 tubes, 2½ inches outside diameter.....	14 feet 1¼ inches long.
Fire surface in tubes	963 square feet.
" " firebox	81½ " "
Area of grate.....	24½ " "
Diameter of wheels.....	43 inches.
" " cylinder	19 " "
Length of stroke	22 " "
Works steam at full or half stroke.	

The other illustration, Fig. 2, is a wood engraving made from a photograph by Mr. R. McMurray, now chief inspector in New York for the Hartford Steam Boiler Insurance Company, and represents one of the Winans engines, which was rebuilt at the Mount Clare shops in 1864. A comparison of the two illustrations will show that some alterations were made in the process of rebuilding, which will be referred to later on.

Winans' shops were located in Baltimore, east of and adjoining the Mount Clare-shops of the Baltimore & Ohio Railroad, and the writer was an apprentice there from 1852 to

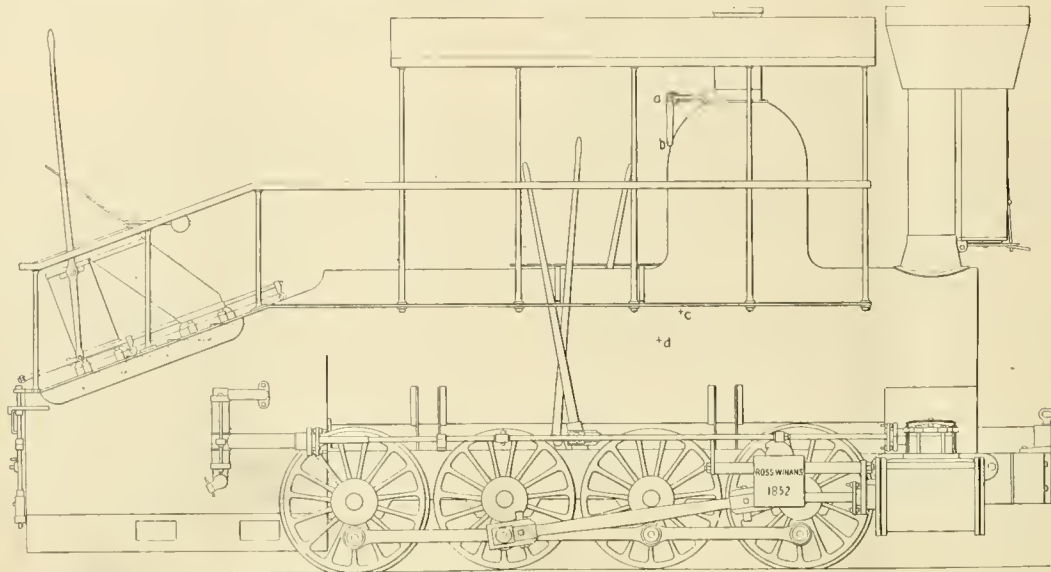

Fig. 1.—Original Winans' Camel Engine.

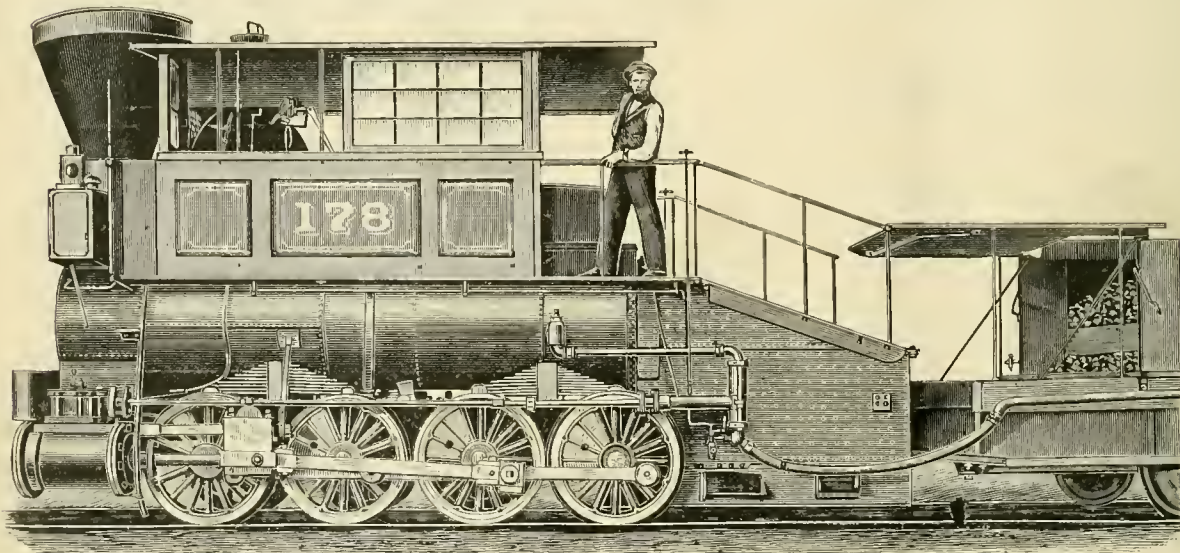
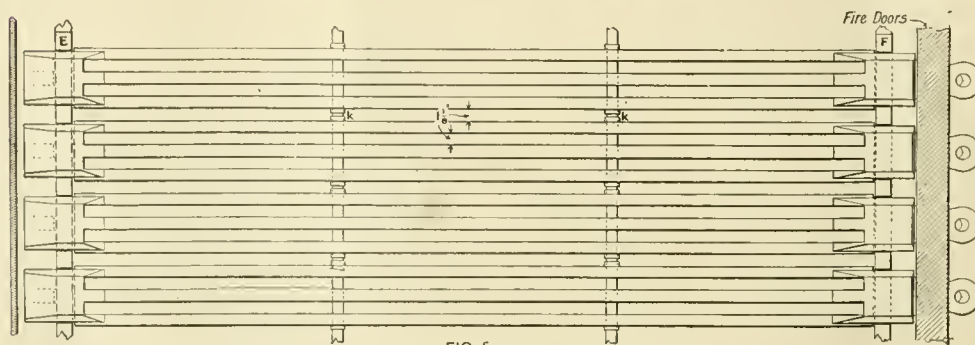
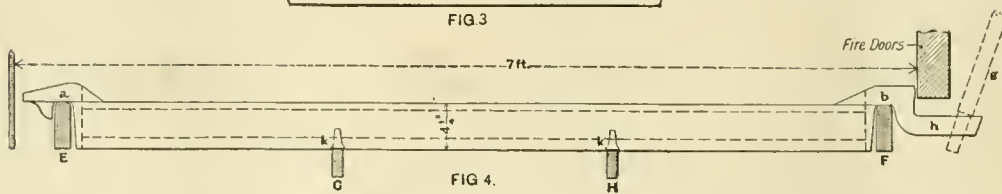
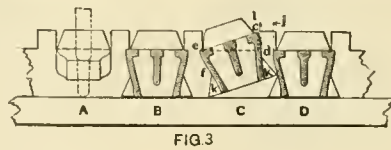

Fig. 2.—Rebuilt Winans' Camel Engine.



Figs. 3, 4 and 5.—Grates, Winans' Camel Engines.

1856, and worked on the engines, and was therefore very familiar with the locomotive here described.

Just how the term "Camel" engines originated is not definitely known. It has been said that a man named Campbell, who designed the first "American" type of locomotive, with four coupled wheels, and a four wheeled truck, which was built in Philadelphia, had something to do with the construction of the first Winans engine of the "Camel" type, and that the term was a modified form of Campbell's name. Another version is that the large dome and cab on top of the boiler gave the engine a humped appearance analogous to that of a camel's back. A third is that the term was used in derision of the builder, who was very stooped and round shouldered, so as to appear almost deformed. Probably the second is the true origin of the term.

In the light of nearly fifty years experience, the merits and demerits of these locomotives may be recognized more distinctly than they were at the time they were built and in use, when they were the subject of much acrimonious discussion and bitter controversy. As will be seen from the illustration, the whole weight of the engine was on the eight driving-wheels, which had a wheel-base of about 11 feet 2½ inches, only a little more than some six-wheel trucks now used under sleeping cars. Consequently these locomotives would pass around curves and into sidings of such short radii, that an ordinary eight-wheeled American engine could not run over without danger of derailment. Having all their weight on the driving-wheels, they had great adhesion, and the small wheels combined with relatively large cylinders gave them great tractive power. The camel engines were therefore noted in their day for pulling heavy trains. Whether the weight given—24 tons—was intended to mean tons of 2,000 or 2,240 pounds, it is not now possible to know, but from the fact that the weight of locomotives is generally greater than it is reported, it is probable that these engines weighed nearer 63,760 pounds, or 24 long tons, than 48,000 pounds, or 24 short tons. They therefore had only 6,720 pounds on each wheel. As the standard rail of those days was made of iron, and weighed only 56 pounds per yard, the importance of having a light weight on each wheel is apparent.

The feature which will first strike a person not familiar with the design of these machines is the form of the fire-box. The top of this sloped downward from the back end of the cylindrical part of the boiler. The outside shell and the crown-sheet were both flat, and stayed with stay-bolts in the usual way. There was nothing especially novel in this form of construction even at this early day, as Stephenson's original "Rocket" had a fire-box, the top of which was depressed below the top of the cylindrical part. In some of the illustrations now extant, it is represented as sloping for only a part of its length, while in others it is shown sloping its whole length. At present the origin of this form of construction is not a matter of much importance, but its utility is. This kind of fire-box was employed quite extensively on the Reading Railroad, by Mr. Millholland, and was later adopted on the Pennsylvania road, on what are known as the old "Class I" locomotives, which are now designated as "H 1" under the new system of classification. The grates of the engine represented in the engraving were about 7 feet long, a very great length in their day. The fire-box was made the full width that was available between the back pair of driving-wheels. The boiler consequently had a very large grate area—equal to nearly 2½ per cent. of the total heating surface—and a large amount of coal could consequently be burned. The camel engines, therefore, had the reputation of being very free steamers. It will be seen that these locomotives had the three essential elements required to pull heavy trains. 1st, plenty of adhesion; 2d, large tractive power, and 3d, ample steam generating capacity. These features were of very great importance in the heavy grades of the Baltimore & Ohio and other railroads, and accounts for the extensive adoption of this form of loco-

motive in its day, and due credit should now be given to Winans for the combination of these elements in his engines.

As will be seen from the illustrations, the long fire-box overhung the back axle, and its weight had to be balanced by that of the cylinders, smoke-box and chimney, which overhung the front axle. In order that they should balance each other it was essential that the fire-box should be as light as possible, and doubtless it was for this reason that the sloping top was adopted, and that the dome was placed at the front end, and the engineer's cab on top of the boiler. The fireman's foot-board was on the tender, as shown in the wood engraving, and was very low down. In those days it was considered essential to keep the boiler as low as possible. The center of that of the engine here described was only about 67 inches above the top of the rail. That of the celebrated 999, on the New York Central Railroad, is 107½ inches, which shows the difference in this respect in the practice in the fifties and at the present time.

With the experience of half a century to guide us, much can now be said in favor of this form of fire-box. The boiler shop of the Pennsylvania Railroad, at Altoona, was formerly under the charge of a very intelligent foreman, Mr. Nixon. A few years ago the writer made especial effort to ascertain, in the light of past experience, what were the advantages and disadvantages of this form of fire-box. In consultation with Mr. Nixon he said unhesitatingly, that what was then known as the "class I" fire-box, which was similar to the camel form, was the cheapest one to build and to maintain, and also the lightest of any in use on the road. If these claims rest upon a sound basis of fact, and are sustained by experience, they are very strong arguments in favor of this form of construction. To ascertain the objection, if any existed, to the use of this form of boiler, some of the men who had run such engines, the round-house foreman and others were consulted. It was said by some of them on the Pennsylvania road that the class I boilers were rather poor steamers, and did not carry water very well.

On the Baltimore & Ohio, and also on the Pennsylvania road, there are still a number of men who ran camel engines when they were in use. Their general testimony was that the "old camels" were free steamers, and there was no difficulty in carrying water in them. It is, of course, true that in this form of boiler there is less steam-room than in one which has more or less steam space over the crown-sheet. This deficiency was compensated for in Winans' boiler by the large dome, which was placed near the front end. This, as will be seen from the engravings, was very large—almost 40 inches diameter—and 48 inches high. The poor steaming capacity of the class I boilers may be attributed to a deficiency in heating surface, and their disposition to "work water" to a lack of steam-room. The camel boilers had neither of these defects.

If then it can be said that this form of fire-box weighs less, costs less and is cheaper to maintain, generates steam freely, and carries water well, it is very strong evidence in its favor. The general principle has been enunciated and is undoubtedly a sound one, that within the limits of weight and space to which we are necessarily confined, a locomotive boiler can not be made too large. If now we were called upon to design a locomotive of almost any class to weigh, say, 100,000 pounds, if this form of fire-box was adopted it would be possible to increase the heating surface some hundreds of square feet and give the boiler greater water capacity than would be possible if the old-fashioned crown bars, radial-stays, or the Belpain form of fire-box was adopted. The inquiry may then be fairly put, whether a locomotive with a fire-box, the construction of which conforms to the predilections of its designer, but with materially less heating surface than another of the "camel" form, would do as much work as the latter in active service?

Another interesting feature in the fire-boxes of these old engines was the coal chutes on top, which are shown in Fig. 1.

When grates as long as 7 feet were adopted, it was supposed that it would be impossible to distribute the coal properly over so great an area. Winans, therefore, supplied his boilers with a pair of chutes on pipes, which were square in section, and of the form of an inverted letter V, which were attached to the top of the sloping fire-box as shown. There was an opening at the base of each of these, similar to furnace doors, and communicating with the fire-box, and closed with sliding doors over them, which were operated by a long lever, also distinctly shown. The top of the chute was closed with a hinged door, having a counter-weight, as shown in Fig. 2, so adjusted that it would hold the door either open or shut in whichever position the door was placed. The foot-board of the tender, from which the boiler was fired from the back end, was placed very low down—about on a level with the bottom of the fire-box. Over this was another platform high enough above the lower one so that the fireman could work below it, but it was in such a position that he could, without much difficulty, shovel coal from the tender to the top landing, as it might be called. From Fig. 2 it will be seen that the coal chutes were removed when the engine was rebuilt. The platform over the fireman's footboard was also removed. The covering shown is only a roof or awning, to protect him from rain and sun. Winans' plan for firing contemplated that the coal should be shoveled to the top platform, and the lower sliding doors of the chute being closed and the top one opened, the chutes were filled with coal. The top door was then closed and the lower ones were opened, which would thus allow the coal to fall on the fire, without opening direct communication with the outside air. Winans' plan looked very well in theory, but in practice the use of the chute was soon abandoned, and when the engines were rebuilt the chutes were taken off. Another peculiarity of many of the fire-boxes which Winans made, was that the whole back end was left open and the aperture was closed by a system of fire-doors. The hinges and some of their fixtures are shown in Fig. 1.

The grates were also peculiar and are illustrated by Figs. 3-5. Fig. 4 is a side view of one of the bars, which were 7 feet long. They were supported by two cast-iron bearing-bars, E and F, and rested on two intermediate wrought-iron bars, G and H, placed underneath, between the two ends. The form of the bars is shown by the sectional view, Fig. 3. From Fig. 4 it will be seen that they had necks, a and b, at each end, which rested on the bearing-bars. The under sides of these necks were on the same horizontal plane as the tops of the bars. An extension, h, on each bar projected below the fire-doors to the outside of the fire-box. Each of the extensions had a hole in it—shown in the plan, Fig. 5—to receive a shaking-bar, g, part of which is represented by dotted lines. Each of the grate bars could thus be shaken independently of the others, as shown by the bar, C, in Fig. 3, which is tilted on the corner, e, of the under side of the neck. The bar could be similarly rocked on the other corner, c. The outer edges of the bars, as c d and e f of C, are described from the corners, c and e, as centers. That is, c d is described from e as a center, and e f is described from c. The effect of this was that when the bars were tilted or shaken the spaces between them, as i j, were not increased or diminished, so that lumps of coal were not liable to fall between the bars when they were rocked and thus clog them. As each bar could be shaken separately from the others, there was less liability of the whole grate being clogged than there is when all the bars are connected and shaken together. To shake the different bars, as has been explained, a bar, g, was inserted in the holes in the ends of the extensions.

The grate was a marvel of cheapness. There was not a bit of machine work on any part of it, excepting that required to drill a few bolt holes in the outer ends of the bearing-bars, and if one of the grate bars was burnt or became distorted and had to be replaced it was simply lifted out and a new one put into its place without disturbing any other

part of the grate. Between the two ends of the bars they were provided with projections, k k, which rested on the bearing-bars G and H, on which they rolled when the grate-bars were rocked. Altogether it seems to be the simplest form of shaking grate that has ever been used.

From the first engraving it might be supposed that a double smoke-stack or chimney, such as has been illustrated recently, was provided on these engines. Such was not the case, however. The front vertical pipe, which is shown in Fig. 1, was intended to serve the purpose of a receptacle for sparks and, as will be seen, had a door at the bottom for removing them. The top of the stack was rectangular in form and had for a spark arrester iron slats placed close together and standing up edgewise, instead of wire netting.

The smoke-box was provided with a variable exhaust, which consisted of a cast-iron box of the form of a frustum of a square pyramid, with a vertical division in the middle and open top and bottom. The exhaust-pipes were connected with the bottom openings. Into each of the two spaces in which the pyramidal box was divided, a loose vertical wedge shaped cast-iron partition was fitted, which could be moved horizontally. They were attached to horizontal shafts which were operated by two spiral cams or "worms" on a horizontal shaft which was connected with the cab by another shaft, and the two were connected together by a pair of bevel gears. In practice the movable partition referred to soon became immovable by the action of grease and cinders, and they were usually placed in their most effective position and left there.

The throttle lever was also different from anything which is used now. It consisted of a horizontal shaft, the end of which is shown at a in Fig. 1. This had an eccentric in it which is also shown and was connected by a rod and strap to the throttle stem. The shaft a had two levers, a b, attached to its ends, with horizontal handles extending outward from the levers in their lower ends. An end view of one of them is shown at h. To open the throttle valve these handles were raised upward and moved in an arc of a circle described from the center of the shaft a. Any jar had a tendency to cause the handles and levers to fall, and thus close the valve. The gage cocks were below the engineer's foot-board, about in the position indicated by c d, and the engineer was obliged to judge of the height of the water by the sound of the escaping steam and water alone. This was before the days of glass water gages. The safety-valves were held down by long levers which had spring balances on the ends.

The wheels with which Winans equipped these engines were solid cast-iron with chilled treads and without separate tires. His assumption being that it was as easy to take a wheel off of an axle and put a new one on as it was to renew a tire. On the Baltimore & Ohio and other roads the engines were, however, speedily equipped with wheels having removable chilled cast-iron tires. These were fitted to the wheels with a tapered seat and were held on with hook-headed bolts let into recesses cast in the wheel centers, the hooked head taking hold of the tire on the outside, and the nut had a bearing on the wheel center inside. An illustration of this method of fastening tires is given on p. 287 of the first edition of the *Catechism of the Locomotive*.

Winans was among the first, although not the first, engineer in this country to use solid-end coupling rods. He was roundly abused for it in his time, but the general practice of to-day conforms to what he advocated and practiced half a century ago.

The frames of his engines, as indicated in the illustration, were of the plate form and each frame consisted of two wrought-iron plates $\frac{5}{8}$ inch thick. These were placed about 5 inches apart and were held together by bolts which had thimbles between the plates. The jaws were faced with cast-iron shoes; the main driving-boxes alone had wedges on one side only. The lower part of the smoke-box was square in form and made of sheet-iron about $\frac{1}{4}$ inch thick. The frames

and cylinder fastenings were, however, very weak and were constantly giving trouble.

The springs were originally placed between the plates which formed each of the frames and rested directly on the top of the driving-boxes. One-quarter inch bolts, which pass through the two frame plates, acted as a fulcrum for the springs. On the Baltimore & Ohio Railroad the springs were placed above the frames, as shown in Fig. 2.

The valve-gear would be a curiosity if a drawing of it could be reproduced to-day. The rockers were made of cast-iron—the end of the upper arm of one of which is shown in the engravings. It was long and of the form of an inverted letter L, and extended from the inside of the frame over its top and far enough outward so that the valve-stem could be connected to a pin in the upper and outer end, which was cast with the rocker. There were two eccentrics on each side—one for the forward full stroke and one for the back motion. A cam was provided on each side, which cut off steam at half stroke in the forward motion. There was no variable cut-off of any kind. The eccentrics and cams were connected to the rocker by old-fashioned hooks, which were lifted into and out of connection with the rocker by a series of other cams on a shaft under the hooks. This shaft was operated by one of the long levers shown in the engraving. The other one is a starting-bar for moving the rocker when the hooks were not in a position to fall into gear.

The pumps, it will be seen, were located on the sides of the fire-box and were worked by a long rod connected to the cross-head. The valve-stems were on the same horizontal plane as the pump-rods, and in Fig. 1 they appear like an extension of the latter. The connection of the pump-rods to the cross-heads gave trouble by breaking the cross-heads and piston-rods, and in some of the later engines the pump-rods were connected to curved arms fastened to the connecting-rods. The feed water, it will be seen, was delivered directly into the side of the fire-box, a practice which would not be approved now, and was condemned then. As shown by Fig. 2, the check-valve was placed forward and attached to the barrel of the boiler when this engine was rebuilt. This was the usual practice and a plate was often riveted to the inside of the boiler shell, to conduct the water from its point of delivery from the check-valve to the front part of the boiler. The rivets shown on the side of the boiler indicate that such a plate was used in the engine shown in the engraving.

The boilers were made of iron less than 5-16 inch thick, the seams being all single riveted. The plates of the shell at the base of the dome were curved in the form indicated in Fig. 1. The large opening where they were connected together was not strengthened in any way, excepting by some cross-braces at the base, which were attached to single bars of angle-iron riveted to the sides of the barrel of the boiler. The braces were simply flat bars with a $\frac{3}{4}$ -inch hole drilled in them and another in the angle-iron. The bars were laid on top of the angle and bolted to it. The whole arrangement was pitifully weak and resulted in frequent explosions and dire calamity to the poor fellows who ran the engines and were on top of the boiler.

Owing to the great length of the tubes—14 feet $1\frac{1}{4}$ inches—it was found necessary to support them between their ends. A plate was therefore placed about midway between the tube-sheets, with a space between it and the shell of the boiler to permit the water to circulate. The holes in this plate were drilled large enough to allow the tubes to be passed through them without difficulty.

The draw-bars of these engines were different from any which were ever used before or since. They were of the form of a large letter V and were placed under the ash-pan, and riveted to it, the two upper arms of the V being bent upward and were bolted to one of the plates of each frame immediately in front of the back driving axle. The apex of the V extended

behind the fire-box and had an eye to receive a coupling-pin. Another heavy single bar was connected to a large casting, on the tender, between its two trucks, and to the eye of the V-shaped bar. This wretched connection was the only appliance for resisting concussion between the engine and tender. The fireman was down in a position in which he could not see danger ahead, and at some distance from the engineer, so that he could not easily get warning from him. The side timbers of the tender, which are shown in Fig. 2, were so far apart that in case of collision they would allow the fire-box to be driven in between them, and the poor fellow who was at work there was almost certain to be crushed to death, and if not, the horror of being burned and scalded were added. The number who met this fate in these wretched man traps will never be known, but the awful danger of the whole contrivance makes one shudder even at this late date.

From the description it will be seen that the draw-bars were placed very low down and close to the top of the rails. This led to an animated controversy, in which the brilliant but erratic Zera Colburn took a part, about the effect of this position of the draw-bar on the distribution of weight of the locomotive. It was asserted by some that owing to the location of the draw-bar the tendency when the engine was pulling was to raise up the back end of the engine and increase the weight on the front wheels. Winans contended that if the draw-bar was placed at the top of the rails there would then be no tendency to either raise or lower the back end of the engine. His opponents contended that the center of the driving-axle was the neutral point, and that if the draw-bar was placed below it part of the weight of the engine would be lifted off of the back end when it was pulling, and if the draw-bar was above the center of the axle more weight would be thrown on the back wheels when the locomotive was pulling a train. It was an interesting discussion and may be offered to the young chaps as a nut to crack.

The original truck frame under the tenders of these engines consisted simply of springs, which were bolted to the tops of the journal-boxes, and the springs were connected together by heavy wrought-iron bolsters, on which the center plates rested. It was Winans' theory that the wheels of a truck should be placed as near together as they could be, so that they would act "as nearly like one wheel as possible." In accordance with this principle the truck wheels of his tenders were placed so near together that the flanges barely cleared each other.

As mentioned in the first part of this article the details of these locomotives had many interesting features and the whole machine was designed with wonderful skill and ingenuity, and the chief aim of their construction seemed to be to produce locomotives with a maximum capacity at a minimum cost. The safety of the men who had to run them seemed to have received less consideration. The object aimed at was apparently accomplished, as these locomotives certainly did a greater amount of work than any of their contemporaries and Mr. Winans made a princely fortune by building them.

As remarked in the beginning of this article, it is to be regretted that complete drawings of these interesting machines have not been preserved, but it is now probably too late to recover what has been lost.

Pensions have been paid by the Boston & Albany Railroad to an engineer and a conductor after 52 years' service in the form of a check for a year's salary and the men were retired on account of advanced age.

A strong preference for steel car frames was expressed by Mr. James Holden, Locomotive Superintendent of the Great Eastern Railway (England), in a printed interview in the "Railway Herald." He had used cars with steel frames for 30 years on the broad gauge lines of the Great Western and they are still running on the altered gauge line. He stated that some of the steel frame cars that were built in 1873 have still 50 years of life before them. The service in freight trains in England is probably much less severe than ours, yet very long life may be expected from metal frame cars here.

COMMUNICATIONS.

MORE LIGHT ON THE COMPOUND LOCOMOTIVE.

Editor "American Engineer":

Your issue for May gives a brief summary of the very interesting and admirable paper read by Prof. Smart, of Purdue University, before the St. Louis Railway Club. This paper gives data on the performance of the four-cylinder compound locomotive, not hitherto available, and of very great value if conditions under which the data were obtained were such as will make them reliable in regular road work. Some of the results are so different from those obtained on simple engines that it would seem there might have been some conditions under which Prof. Smart's tests were run that make a comparison with the results from the simple engine misleading.

The paper states that engines received steam from a 250 horse-power "Sterling" boiler, but no mention is made of the size of the exhaust opening. This, on a compound engine, has a most important influence on the mean effective pressure at high speeds, and it would be interesting to know whether the size of exhaust opening was such as could probably be used in the regular operation of a locomotive furnishing steam from its own boiler. The paper states that only one side of the engine was used in making these tests, and it would seem important to know whether the full size of exhaust opening designed for exhausts from both cylinders was used, and what the area of exhaust opening was.

The curves showing steam consumption at different speeds are exceedingly interesting, and the results shown of great importance if fairly comparable with those from the simple engine with which they are compared. It is difficult to understand why the curves for the compound at 10 and 11 inch cut off depart so widely at medium and slow speeds. At about 120 revolutions per minute they show a difference of about 3½ pounds of water per indicated horse-power per hour, while at 180 revolutions there is no difference in economy. The loss in economy is also shown to be almost entirely in the tests at 11 inch cut-off, those at the 10 inch cut-off showing a loss of but ½ pound of water per indicated horse-power from 180 to 120 revolutions, while the 11 inch cut off shows a loss of 4 pounds. With the same range of speed the loss of economy of the simple engine at both cut-offs plotted, viz.: 6 inch and 8 inch, is less than 1 pound, and is almost the same for each. Doubtless the reason for this can be explained, but it does not seem clear from the data presented.

These tests were so carefully made, and are of so much importance, that more light on points which seem obscure, it is believed, would add greatly to their value.

E. M. HERR,

Superintendent Motive Power.

Northern Pacific Railway, St. Paul, Minn., May 12, 1898.

Editor "American Engineer":

Replying to questions asked by Mr. E. M. Herr in a communication which appears in the present issue of the "Engineer," proof of which you kindly sent me, I desire to submit the following statements:

The arrangement of the exhaust on the plant in question is of necessity somewhat different from that usually employed. The exhaust passages in the saddles lead to an exhaust pipe 18 inches long, having a bridge 12 inches high. Since but one side of the engine was used, a blank flange was placed between the exhaust pipe and the exhaust passage in one saddle. Instead of a nozzle on top of the exhaust pipe, connection was made with the condenser by a 5-inch pipe about ten feet long. Condensation of the steam took place at atmospheric pressure. Although no tip was used, it is believed that the back pressure produced at high speeds by the arrangement just described was very similar to that found in service. From an examination of the cards, the amount of back pressure and its rate of increase with an increase of speed fully sustains this conclusion.

I can, at this time, offer no explanation of the results obtained in steam consumption. The conditions of operation of the tests at the slower speeds, where a decrease of economy has been noted, were entirely normal, as far as I was able to observe, and the results of the several tests were consistent, one with another.

Further investigations of the subject, which I hope to be able to make when circumstances permit, will probably furnish some additional evidence on the point in question.

R. A. SMART,

Assistant Professor of Experimental Engineering,
Purdue University,

Lafayette, Ind., May 20, 1898.

SUCCESS OF RAILROAD MEN IN OTHER FIELDS OF LABOR.

Editor "American Engineer":

It may be interesting to some of your readers to know that the old theory of railroad men that they are useless in any other field of labor than railroading is exploded by the number of ex-railroad men employed by the Peerless Rubber Manufacturing Co. in their works. Of the 350 hands employed by this company 250 are ex-railroad men, consisting of superintendents, master mechanics, conductors, engineers, firemen, baggage men, brakemen, telegraph operators and clerks. They make very valuable men, as their railroad training has taught them the value of close attention to detail, a vitally important point in a rubber manufacturing establishment.

Our assistant superintendent is an ex-railroad master mechanic. One of our most important workrooms, known as the general make-up room, is under the supervision of a prominent and successful ex-railroad superintendent. Our store house and shipping departments are both under the charge of ex-railroad conductors. The engine and boiler rooms, three distinct plants, are all handled by ex-railroad engineers and firemen. Our hose rooms have over 40 men in them from all grades of the operating service.

It was originally the opinion of the superintendent of our works that railroad men used to out of door life would not make good shop hands, owing to the confinement of indoor work. In this, however, he admits he was agreeably mistaken. A thorough trial has demonstrated that the regular life, hours and wages are very much more to their liking than the old irregular railroad life, regardless of its unexplained fascinations.

Our works are in close proximity to the eastern terminal of the West Shore Railroad, which partly accounts for the large number of ex-railroad men employed. It is quite the regular thing now for the men of the operating department of the West Shore Railroad who resign from railroad duties by request or otherwise, to at once join their brothers in the works of this company. In fact, it is quite a standing rule that the factories of this company are open to all of the West Shore men who desire to learn a trade. They have to commence on small pay of \$1 per day to learn some part of the business, which is usually increased about 50 per cent. In two months, and as soon as they become proficient in their department or work, and in shop parlance, can "hold their hand," they get the regular scale of wages, regardless of the length of service.

One other good feature is their loyalty. In our experience of 18 years we have been perfectly free of labor troubles, with one exception. Last February our hose room was running night and day, and some thirty of the hands in that room decided to strike, and endeavored to induce the entire hose room to go out with them. They failed signally in their efforts, as not one of the ex-railroad men would either listen to or join them, all staying loyally at their work.

In conclusion, we cannot speak too highly of our ex-railroad men as shop hands and workmen. They are, in our opinion, a most decided success.

C. H. DALE, President.

Peerless Rubber Manufacturing Co., New York, May 7, 1898.

FAST THROUGH TRAINS ON THE GREAT SIBERIAN RAILROAD.

Editor "American Engineer":

From the beginning of April this year Moscow has been connected with Siberia by means of a fast through train. This train starts from Moscow, goes through Toula, Batraki (crossing the Volga) and Chelabinsk to Tomsk, a very important Siberian city, traversing the 2,460 miles in less than six days. The mean speed of the train is now about 18 miles an hour, but it will shortly be increased. The train is a vestibule palace-

car train, and consists of five cars, viz.: one baggage car, one dining car and three passenger sleeping cars (two second class cars with 48 berths, and one first class car with 18 berths). The train is lighted by electricity and provided with a bath room, library, cottage piano, writing table, accessories for games and gymnastics, and medicine chest. It is attended by a special rolling stock inspector. The fare for the whole journey from Moscow to Tomsk is very low, being only \$34.00 in the first class sleeping car, and \$21.00 in the second class sleeping car.

The first Siberian fast through train started from Moscow April 1, at 7.35 P. M., and reached Tomsk April 7, at 11.30 A. M. (St. Petersburg time), having been 136 hours on the way. The return train started from Tomsk April 9 at 9.00 P. M. and arrived in Moscow April 15 at 9.00 P. M., having been 144 hours on the way. The arrival of the first through train was celebrated in Tomsk by the local authorities and population.

As Moscow is about 400 miles distant from St. Petersburg, the whole distance from St. Petersburg to Tomsk is 2,860 miles, and can be now traversed in 6½ days.

At the end of this year the Siberian Railroad will be extended to Irkoutsk, 1,000 miles further, and the journey to that city will be about two days longer, that is not more than 8 days from Moscow to Irkoutsk.

The Chinese Eastern Railroad Company is intending to build the Port Arthur branch of the main Mandjuria line this year. This feeding branch will be very important for the purpose of construction of the main line. Mr. Gordon, the Russian agent of the Baldwin Locomotive Works, has already got an order for 20 tank-engines for the branch.

A. ZDZIARSKI.

St. Petersburg, April 30, 1898.

THE TON MILE AND ENGINE MILE IN LOCOMOTIVE STATISTICS.

By W. H. Marshall.

The great mass of statistics compiled monthly by railroad companies are intended to show the income, expenditures, earnings and the cost, in considerable detail, of the service it has rendered its patrons. Upon the general trend of these statistics the management must determine its policy in the government of the great properties entrusted to its care. The necessity of accuracy and clearness in the compilation of these accounts is apparent and needs no argument. The business of a railroad is to move passengers and freight, and the unit of valuable work is the transporting of a passenger or a ton of revenue freight one mile; consequently a company is vitally interested in the cost of these units of work. It has not been deemed feasible, however, to base all statistics directly upon these units of work, even though the determination of their cost has been and is the ultimate object. For the statistics must not only show the cost of revenue paying units in freight and passenger service, but they must be so compiled as to show what each department is doing, and, as in the conduct of its business, cars must be hauled, sometimes empty and frequently but partly loaded, it is necessary in order to determine the cost of the actual work done by some departments to take into account the cars themselves, as well as their contents. For this and other reasons, it has been customary to base much of the statistical work upon the car mile as a unit, and to compute the cost of engine service upon the engine mile unit.

In order that such statistics of engine service may be comparative from month to month, and year to year, it is evident that the amount of work performed by the locomotives for each mile run must remain reasonably uniform. At some

CRANK PIN AND AXLE CALCULATIONS.

Editor "American Engineer:"

Being very greatly interested and profited by Mr. Francis J. Cole's admirable articles on the question of fiber stress and the proper diameters of crank pins, I desire to present, as a

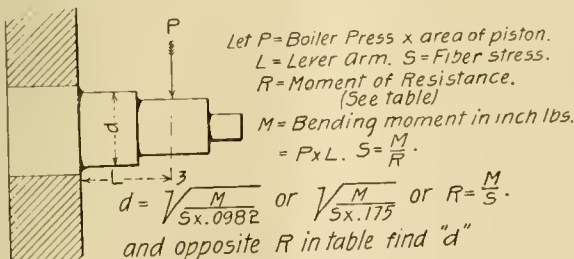

Diagram and Formulae for Crank Pins.

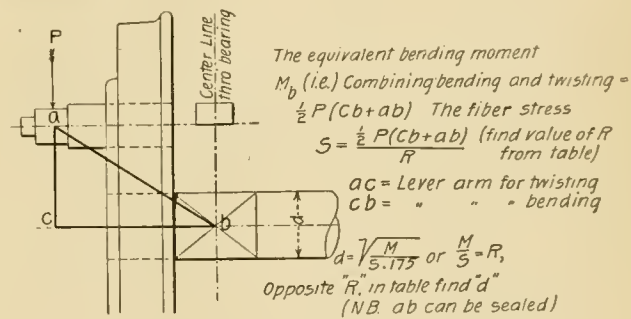

Diagram and Formulae for Driving Axles.

FIBRE STRESSES ALLOWABLE.

	Iron. Pounds.	Steel. Pounds.
Driving axles	18,000	21,000
Crank pins	12,000	15,000

MOMENT OF RESISTANCE, $R = 0.0982d^3.$

	0	¼ in.	½ in.	¾ in.	1 in.	1 ¼ in.	1 ½ in.	1 ¾ in.	2 in.
3 inches.....	2.65	3.00	3.37	3.77	4.21	4.67	5.18	5.71	
4 ".....	6.28	6.89	7.53	8.20	8.94	9.71	10.51	11.33	
5 ".....	12.27	13.32	14.20	15.25	16.36	17.51	18.69	19.83	
6 ".....	21.21	22.60	23.97	25.42	26.96	28.57	30.19	31.80	
7 ".....	33.67	35.40	37.11	39.36	41.42	43.46	45.69	47.94	
8 ".....	50.27	52.66	55.12	57.67	61.04	63.36	65.77	68.63	
9 ".....	71.57	74.59	77.70	80.89	84.17	87.54	90.99	94.54	

VALUE OF "P."

Cylinder Diameter.	Area.	Piston Area by Boiler Pressure.				
		160 lbs.	170 lbs.	180 lbs.	190 lbs.	200 lbs.
12 inches	113.0	18 050	19,210	20 340	21 470	22,600
14 ".....	153.9	24,624	26 163	27 702	29 241	30 780
16 ".....	201.0	32,160	31,170	36,180	38 190	40, 00
17 ".....	226.9	36,304	38,573	40,842	43,111	45,380
18 ".....	254.4	40,704	43,248	45,792	46 336	50,880
18 ¼ ".....	268.8	43 008	45 696	48 384	51,072	53 760
19 ".....	283.5	45,360	48 195	51 030	53 865	56,700
19 ¼ ".....	298.6	47 776	50 762	53 748	56,734	59 720
20 ".....	314.1	50,256	53,397	56,538	59,679	62,820
20 ¼ ".....	330.0	52,800	55,100	59,400	62,700	66,000
21 ".....	346.3	55,408	58,871	62,334	65,797	69,260
22 ".....	380.1	60,816	64,617	68,418	72,219	76,020

CRANK PIN AND DRIVING AXLE CALCULATIONS.

contribution to the general subject, some forms and tables which I have found useful, as a step toward simplifying the question and reducing the data to a "vest pocket" basis. I therefore beg leave to submit herewith, 1st, a table giving the value of the moment of resistance (0.0982 multiplied by the third power of the diameter) from 3 inches to 9½ inches, advancing by eighths; 2d, a table giving the value of "P" (piston area times the boiler pressure) for various diameters of cylinders between 12 and 22 inches, and for varying pressures from 160 pounds to 200 pounds per square inch. And, two diagrams, one giving the formula for figuring crank pins and the other for driving axles, in which the foregoing tables are used.

L. R. POMEROY.

New York, May 21, 1898.

time in the history of railroads this uniformity may have existed, but during the past decade the great increase in the size and power of modern locomotives, and the vigorous efforts made by railroad officials to give locomotives the maximum tonnages which they will haul, have so changed the conditions as to make impossible an accurate comparison of one year's work with another on an engine mile basis; whatever semblance of uniformity of conditions might have existed has been entirely wiped out. We are therefore forced to the conclusion that however valuable it might have been in the past the engine mile is now misleading when employed alone as a basis for calculation of the cost of engine service.

As an illustration of the changing conditions which destroy the value of the engine mile records, I would cite the accounts of one Western road, which show that for a certain number of

months the engine miles, as compared with the same months of the preceding year, increased 18.51 per cent. In the same period the loaded car mileage increased 12.98 per cent., the light car mileage 11.23 per cent., all freight car mileage 12.47 per cent., and the ton mileage 24.95 per cent. With all engine records on the engine mile basis no cognizance would be taken of the difference in work done; if the car mileage were taken into consideration it would appear as if the engines had done less work per mile in the latter period, because the increase in car mileage is less than in engine mileage; but if the tonnage records were consulted they would show that the engines had done more instead of less work.

The question now being discussed is whether locomotive accounts should remain upon the engine mile basis, or whether in common with other statistics they should be computed upon a car mile basis, or whether all statistics should be based on the ton mile as a unit. It must be admitted that no unit can be selected which will not be open to objection. The engine mile has many, and the car mile and ton mile are not free from them. Neither of the latter two take into consideration the question of speed, though this is an important factor in the cost of service. Neither do they take cognizance of the resistance of grades and curves, of atmospheric resistance, nor of several other factors that would have to be considered if the statistics were to be comparable with those of other railroads, or comparisons made between different divisions of the same road. But before condemning a unit because it does not cover all conditions, it may be worth while to inquire whether statistics based on such a unit are worth the cost of clerical labor involved.

To illustrate: The horse power hour might be claimed to be the true unit of work from the standpoint of the motive power department, but what is its value? To obtain it speed and all the factors of train resistance must be taken into account (which is practically impossible), and when obtained it would have little direct bearing on the cost of transportation. It would be of no value outside of the locomotive department, and not so much value inside of it as might be supposed. With the ton mile unit the case is different. All engine service or operating department statistics computed on that basis can be used directly in determining the total cost of transportation, without converting them into any other units. In the writer's opinion the ton mile is a better unit than the car mile because notwithstanding the conditions which it does not take into account, the ton is always a ton, while the car may be a 30,000 lb. affair or it may be a freight house on wheels. Without attempting to go further into this phase of the question, we will accept for the present the ton mile as a superior unit to the car mile, and will consider some reasons why it should be adopted in locomotive expense accounts in preference to the engine mile.

We have stated that statistics to be of much value should show clearly the cost of the work done; that our locomotive account on an engine mile basis does not give this is certain. No better proof is to be found than in the case of modern heavy freight locomotives; we know that such engines are economical because per unit of work performed they cost less for fuel, for wages, for repairs and for oil. Accounts kept on the engine mile basis, however, do not demonstrate this fact. Per engine mile they cost more for repairs, a great deal more for fuel and at least as much per mile for wages; thus the engines that are the most economical to the company appear most extravagant on the records, and in order to demonstrate their economy we must determine the tonnage hauled and from the present engine mile accounts deduce the cost of service on the ton mile basis. It would, therefore, seem as if these accounts might be originally computed on this basis.

To illustrate this condition of affairs I would cite the performance of some 17x24 inch, and 19x26 inch engines in freight service on a certain division of the Chicago & North Western Railway in February, 1898. The 17-inch engines are more numerous than the 19-inch, but there were enough of each to give a fair comparison. The figures are as follows:

Comparison of 17x24 and 19x26 inch engines for February, 1898:

	17 x 24.	19 x 26.
Ton miles	26,789,289	17,314,508
Train miles	67,450	22,575
Engine miles	74,195	24,713
Average tons per train	397	767
Coal used (tons)	3,780	1,542

Engines.	17x24-inch.		19x26-inch.	
	Engine mile basis.	1,000 ton mile basis.	Engine mile basis.	1,000 ton mile basis.
Total cost of engine service in cents, including engine crew wages.....	17.73	49.03	20.85	29.67

In the above statement the coal, oil and waste, dispatching or hostling and engine crew wages are exact. The repairs and round house labor are estimated because the large engines are new, and accurate figures on the repairs in particular were not available. The cost of repairs estimated for the larger engines was much greater per engine mile than for the smaller ones, and was based upon what other large engines are known to be costing. Over 80 per cent. of the costs above shown are actual, and the possible error in the estimated items could not influence the general result. The figures are striking because they show that while the operating expenses of the large engines were 20.85 cents per mile, as against 17.73 cents for the smaller, or 3.12 cents in excess, they only cost 29.67 cents per 1,000 ton miles, as against 49.03 cents for the smaller engines. In other words, on the engine mile basis they cost 17 per cent. more to operate and on the 1,000 ton mile basis they saved 39½ per cent., as compared with the 17-inch engines. This statement shows how misleading the engine mile accounts may be in some cases.

The cost of fuel is such a large item and the necessity of economizing in its use has become so urgent that many railroads in order to achieve the desired results have found it necessary to put the cost of fuel upon the ton mile basis as far as the individual records of the engine men are concerned. The road with which the writer is connected adopted this course some years ago, and with decidedly beneficial results. On the engine mile basis the smaller the train hauled the more favorable the enginemen's records appeared; consequently there was no incentive for an engineer to handle trains that called for the maximum capacity of the engine. By placing the individual coal records upon the ton mile basis all this was changed, for it was at once shown that, other things being equal, the engineer hauling a light train could not hope to show up as well as a man hauling a heavier one. The heavier the train the less the coal consumption per hundred ton miles, consequently there is every inducement for the engineer to handle the heaviest train with which his engine was capable of making the speed required by the operating department. So great have been the gains from the introduction of the individual coal records based on the ton mile that it would seem desirable to have the total monthly performance shown in the same way. Though this is not done on the summary, the performance of each division is in reality checked up by the ton mile figures.

Not the least of the advantages which comes from placing the coal record upon the ton mile basis is the unity of purpose which it helps to give to all officers in the operating and mechanical departments, and to many of their employees. There may be many men who are broad-minded enough to pursue a course which will make their own records appear in an unfavorable light, though resulting in economy to the company they serve, but we can hardly expect that every man will so act. Yet that is exactly what every official and every engine crew ought to have done under the old method of computing the record of fuel on the engine mile basis. If he had a sufficient insight into the economies of railroad operation to realize that a heavier train was more economical to the company it was certainly his duty to do all he could to bring about the heavier loading of engines, even though his own accounts were going to show heavier expenses per engine mile. But if a motive power official considered only the showing of his own department he would have sought the light train loading, while the operating department official, also having in mind only his department, would have endeavored to increase the train loads. The interests of the two departments were then not identical. By placing the fuel account upon a ton mile basis the mechanical and operating departments are not only brought together on an economical course, but they obtain the co-operation of every conscientious and careful engine crew.

The advantages of placing the fuel upon the ton mile basis have been so apparent that some officials have been led to advocate showing all other locomotive expenses upon the same basis on the monthly performance sheet, and there is much to be said in favor of this plan. Engine crew wages and repairs are two very large items in the total cost of locomotive expenses, and the reasons for placing them upon the tonnage basis are of much the same character as outlined in the case of fuel, except that the showing on these items would probably influence and impress officials rather than employees. When operating officials are making strenuous efforts to increase the tonnage of trains we sometimes hear mechanical officials say their engines are so heavily loaded that the cost of repairs is increased, and some who have not gone to the root of the matter are inclined to think the company is losing more in the additional cost of maintaining the locomotives than is saved in other directions by the heavy tonnage assigned to the engines. If repairs were computed upon the ton mile basis such officials would quickly find out that the heaviest trains which their engines could haul would be best for their records and

that every light tonnage train that passed over the road was detracting from the showing of the motive power department at the end of the month or year.

The cost of engine crew wages is one which, while it may remain constant per engine mile under the schedules that may now be in force, should be put upon the tonnage basis in our accounts, if for no other reason than to give us constantly an example of the economy due to heavier trains by showing how this item reduces per ton mile as the trains increase. The items of oil and waste, dispatchers and wipers, and round house laborers can all be computed with advantage upon a ton mile basis.

While these advantages are conceded, there is, however, something to be said in favor of retaining the present accounts, and in fact, showing the expenses both on an engine mile and ton mile basis. For instance, let us take the dispatching or hostling of engines. It costs no more in hostlers' wages for handling a large engine at terminals than for a small one, and if this account was placed on the ton mile basis there would be a tendency for it to decrease with every increase in the average weight of the train, whether such an increase was due to a heavier rating of the engines, a better average loading by the operating department or any other local or general condition. The mechanical department might thereby claim for itself an economy which should not be credited to it; even if it did not do this, it is apparent that the account would not show upon its face the actual cost of hostlers' services per engine handled, and whether it was in reality increasing or decreasing could not be shown except by a special statement. Others items would be equally in need of a side light thrown upon them in the shape of cost per engine mile. In fact, this necessity of a side light is found even in our individual fuel accounts, and perhaps I cannot do better than to cite an actual case. The attached table is taken from the fuel record of a number of men who are supposed to be in strictly comparative service:

Engine Crew.	Engine Mileage.	Tons of Coal.	Miles run per Ton.	Ton Miles.	Pounds of Coal per 100 Ton Miles.	Average Weight of Train.
1	2,584	135	19.1	1,442,762	18.7	558
2	2,042	127	16.0	1,238,428	20.5	606
3	2,512	146	17.2	1,295,295	22.6	516
4	2,837	162	17.5	1,383,900	23.4	488
5	2,398	126	19.0	966,028	26.0	403

It will be seen that the average weight of trains hauled by them during the month varies from 606 to 403 tons, and that the man with the lowest tonnage is also the most expensive on coal per hundred ton miles; this may be expected to some degree, but in this particular case it looks as if he was more expensive in fuel than his reduced tonnage would warrant. Had we no account on the engine mile basis a decision might not be reached with any degree of certainty, but by looking at his miles run per ton we find that he did not run as many miles as the engineer who had a 558 ton train. The suspicion therefore raised by his record on hundred ton miles is confirmed, and when asked by his master mechanic why he did not do better he cannot make his light train an excuse.

The same argument in a measure applies to the other items that enter into locomotive expenses. If we should place them all upon the ton mile basis and with the incentive thus given, the operating and mechanical departments should both work hard to increase the average tonnage of all freight trains, the locomotive accounts would be certain to show an economy over previous records. Whether the economy is all it ought to be under the changed conditions cannot always be known without consulting the engine mile accounts; for this reason the writer favors showing the accounts both on a ton mileage and engine mileage basis.

There is one other matter in connection with this subject that is seldom touched upon, but which is nevertheless of considerable importance; this is the separation of the expenses of passenger and freight service. The mileage in each service is given on monthly performance sheets, but the expenses of the two services are not shown separately. The cost on the ton mile basis of both fuel and repairs is greater in passenger than freight service. If the ratio between the tonnage in the two services does not remain constant the combined costs of engine service will fluctuate without any apparent reason. The separation of the expenses is desirable from some standpoints, but whether the additional labor is justified each road must judge for itself. It appears clear to the writer, however, that with a separation of passenger and freight engine expenses and the costs shown both on the ton mile and the engine mile basis, the actual cost of each service would be obtained and a minute analysis of all items would be possible. Whether the separation of the passenger and freight engine expenses would be justified may be an open question, but it appears to be essential to compute expenses on both engine mile and ton mile units.

BOILER FOR STEAM MOTOR CAR—NEW ENGLAND RAILROAD.

The chief of the general features of the steam motor car, built by the Schenectady Locomotive Works for the New England Railroad, were presented in our issue of November of last year, and we now show the details of the construction of the boiler.

This is an upright, fire tube, cylindrical boiler with an en-

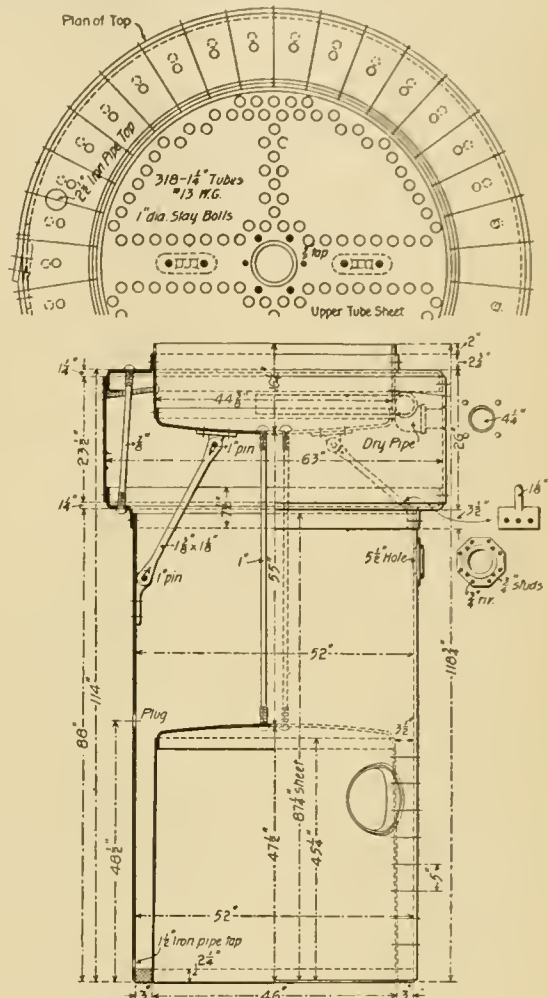

Motor Car Boiler, Schenectady Locomotive Works.

larged steam space in the form of a drum. The chief dimensions are as follows:

Outside diameter Top, 63 in.; bottom, 52 in.
Steam pressure 20 lbs.
Firebox, diameter 45 3/8 in.
" depth 47 1/2 in.
Water space 3 to 3 1/2 in. all around
Tubes, 1 1/4 in., number 318
Total heating surface 643 sq. ft.
Grate area 11 1/4 sq. ft.

The firebox is stayed with 1-inch Taylor iron staybolts, and the method of staying the other surfaces is clearly indicated in the drawing. The upper tube sheet is dished and braced to the iron sheet and to the shell and is riveted to a welded ring to form the throat connection to the top of the shell. The dry pipe is in the form of a semi-circle of 3-inch wrought iron pipe, which is 40 inches long before bending and lies against the throat connection sheet at the top of the boiler. It is perforated by 400 1/4-inch holes in four rows of 50 holes each in its upper surface. The same drawings were used in the construction of the boiler for a similar car for the Erie Railway.

The Richmond Locomotive and Machine Works has just received by cable an order from the Finland (Russian) State Railway for seventeen compound locomotives. This is a high tribute paid to American industry, the Richmond Locomotive and Machine Works being wholly without influence in Russia and the order being given entirely upon the merits of workmanship.

Mr. Daniel S. Newhall, Assistant Secretary of the Pennsylvania Railroad, has been appointed Purchasing Agent of the road.

COMBINED DINING AND RESTAURANT CARS—INTER-COLONIAL RAILWAY OF CANADA.

We have received from Mr. F. R. F. Brown, Mechanical Superintendent of the Intercolonial Railway of Canada, a floor plan of an interesting arrangement combining a regular dining car, with its appurtenances, with a restaurant room. The drawing presents the chief dimensions and shows the arrangement of the car, the passage ways and the accommodations in such a way as to require no explanation.

Three of these cars were recently converted from first class passenger coaches and it was a difficult matter to provide for the kitchen and accommodation for both first and second class passengers in cars only 54 feet long, especially when the kitchen, pantry and cupboards take up nearly half of the

tions or mixtures easy by this characteristic, and that the saponification equivalents of most of these oils are so nearly alike makes the examination of oils for admixtures or falsifications one of the most difficult that comes to the commercial chemist. Notwithstanding, however, the obstacles above mentioned, a number of methods for testing oils as to their purity or freedom from falsification or admixture, have been proposed, some of which are quite successful. Among these may be mentioned microscopic examination, applicable to fats which crystallize; relative solubility of these substances in different menstrua, applicable in a limited way to all fats; saponification, applicable to all mixtures of saponifiable and non-saponifiable oils; melting and chilling points, applicable in a confirmatory way, in a very large number of cases; color reaction with oil of vitriol, of limited use and value; elaidin

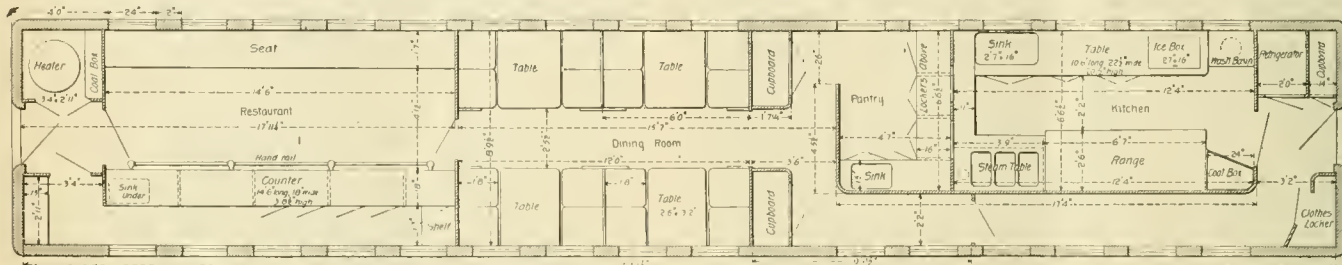

Combined Dining and Restaurant Car, Intercolonial Railway, Canada.

length. One of the conditions imposed was that a standard, full-sized range, with steam table and other fittings, were to be used, in order that these may be used again in case it was decided to replace these cars with first class, full length dining cars. The same kitchen and refrigerator equipment would be put into the larger cars, and the 18-foot counter from the restaurant end would also be used.

In the dining compartment is room for but four tables, yet their arrangement seems excellent for such a limited accommodation. The cars are to be considered as experimental, and while ample to meet the requirements during winter months it is possible that larger ones may be built when the demand increases sufficiently. It is understood that no changes were made in the framing or other parts of the car bodies, except where necessary to put in the new fittings.

CONTRIBUTIONS TO PRACTICAL RAILROAD INFORMATION.

Chemistry Applied to Railroads—Second Series—Chemical Methods.

XXIV.—Maumené's Test for Oils.

By C. B. Dudley, Chemist, and F. N. Pease, Assistant Chemist, of the Pennsylvania Railroad.

Explanatory.

Perhaps no class of commercial products are more easy to adulterate or falsify, and certainly none are more difficult to detect adulteration in, than the fixed animal and vegetable oils. The very large number of kinds of oil in the market, differing widely in price, furnishes the opportunity for mixing, with the expectation of selling the mixture at the price of the more expensive constituent, while the fact that almost all of these oils mix readily with each other, even without the application of heat, makes adulteration simple and easy. It is only necessary to add the various oils the mixture is designed to contain, to a tank and stir, and you have a quantity of oil ready for barreling. Furthermore the following facts, viz., that very few of the fixed animal and vegetable oils have any characteristic odor, color or taste, that they differ very slightly in specific gravity, that their optical behavior does not differ sufficiently to make the detection of adultera-

test with nitric acid, likewise of limited use and value; the iodine and bromine absorption tests, which are of very wide application, and of much value, and the nitrate of silver color reaction, applicable to certain burning oils, in which it shows quality, rather than admixture.

This list might be very much extended, and still not exhaust the subject, but it is wide of our present purpose to write a treatise on oil testing. We simply want to describe what in our experience has been found to be one of the best of the tests for the fixed animal and vegetable oils. It is fair to say that the kinds of test to be applied in any case, are generally determined by the previous history of the sample, or by knowledge or suspicion, as to what may be present, and that any or all of the above tests, or even other, may be used in our laboratory, in working on a sample of oil. If we may trust our experience, no single test is final, that is, no single test is known to us, by the application of which it is possible to say that a sample of any oil is pure and free from admixture. On the other hand the Maumené test, described below, is, so far as our experience goes, the best single test now known. It is susceptible of as wide application as any single test known to us, and its results are as valuable. Still further the ease of its application, the simplicity of the manipulation, and the rapidity with which results can be obtained, all recommend it to favor.

Operation.

Have a bottle of concentrated oil of vitriol, such as is described below, at the temperature of 80 degrees F. for all oils which are limpid at that temperature. For fats having higher melting points, a higher temperature may be used. It is essential that the fat to be tested should be limpid, and the temperature necessary to secure this result may be used. Measure with a pipette into a beaker, which must be perfectly dry inside and outside, such as is described below, 20 cubic centimeters of the oil to be tested, which must be free from moisture. In some cases, as will be described below, less must be used. Introduce a thermometer reading to at least 212 degrees F., and by warming or cooling as may be necessary, bring the oil, beaker and thermometer to the same temperature as the acid. Now by means of a pipette, add to the beaker 10 cubic centimeters of the acid. Then grasping the beaker near the top, between the thumb and first two fingers of the left hand, so as to leave the bottom untouched, and at the same time inclining the beaker a little, stir with

the thermometer, so as to produce as intimate a mixture of the oil and acid as is possible, in as short a time as is possible. A reaction immediately follows, accompanied by the development of considerable heat. Observe the thermometer from time to time, for which purpose a momentary cessation of the stirring is necessary. The temperature will be found to rise gradually, until a maximum is reached. Observe and make a note of this maximum temperature, and treat the figures as described under "Calculations." A little experience enables duplicate determinations to be made, which agree within a degree or two, in the maximum temperature found.

Apparatus and Reagents.

Plain or lipped beakers about two and one-half inches high, and an inch and three-quarters in diameter at the bottom, are a convenient size for this test. When a number of different ones are used, it is essential that they should be very nearly alike in dimensions and weight. Either ordinary chemical or milk scale thermometers may be used. The bulb holding the mercury should be so short that the oil and acid completely cover it. Where a number of different thermometers are employed for this work it is essential that they should read alike, both at the temperature of starting the operation and at the maximum temperature. It is hardly safe to use them as they are received from the market, without testing.

The quality of the oil of vitriol employed is of the greatest possible importance. It is rare that two different bottles or two different carboys of acid will give exactly the same results on the same sample of oil, and concentrated C. P. sulphuric acid gives very wild results. Some experiments have been made looking toward finding an explanation of these irregularities, with the idea in mind of making it possible to use any acid, but these experiments have not yet led to any satisfactory conclusion. Accordingly it has been found desirable to test the acid from a number of different bottles or carboys, with a sample of any oil known to be pure, and set aside for future use the bottle or carboy which gives with this pure oil, a maximum temperature, corresponding most closely with previous practice. If this bottle or carboy is kept carefully stoppered the figures given by it can be used as long as the supply lasts. When a new supply is needed, the same process of selection is repeated, either with or without change of the figures showing maximum temperature, as may be shown by the experiments.

Calculations.

The difference between the initial temperature used at starting the experiment and the maximum temperature found, which may be called for convenience the "rise in temperature," are the figures which are useful in the calculations. It is believed that each fixed animal and vegetable oil, in a state of purity, has its own characteristic rise in temperature when treated as above described. If it is desired, therefore, simply to know whether a sample of oil of any kind is pure or not, it is, so far as Maumené's test is concerned, only necessary to know whether the rise in temperature given when a sample of the kind of oil in question, which is known to be pure, is the same as that given by the sample about which information is desired, both being tested as described above. If the figures given by the pure and the unknown sample are the same, then so far as Maumené's test can tell, the unknown sample is pure. For example, if pure lard oil shows a rise in temperature when tested as above described of from 78 to 80 degrees F., and no other known oil gives this rise in temperature, it is deemed safe to assume that any commercial oil which gives this rise in temperature is, so far as Maumené's test can show, pure lard oil. As will be explained below, even though the figures given by Maumené's test are satisfactory, the sample in question may not be pure oil, and further tests may be needed to decide the point. Here we are only illustrating how to use the Maumené test. This test likewise has a still further use. If it is known that a sample of oil is made up of two kinds of oil, and if the rise in temperature characteristic of each of the constituents is

likewise known, the proportions of each in the mixture may readily be obtained as follows: Assume the rise in temperature of one of the constituents to be (a) degrees F. and of the other (b) degrees F., while the rise given by the mixture is (c) degrees F., what is the proportion of each in the mixture? This may readily be found by substituting the figures found, in the following formula:

$$100 \frac{(c-a)}{(b-a)} = \text{per cent. of oil (b), and this being known, the}$$

percentage of the other constituent is found by subtracting from 100. The derivation of this formula is readily determined algebraically, and is perhaps not necessary here.

Notes and Precautions.

It will readily be noted that this test is based on the fact that strong oil of vitriol mixed with the animal and vegetable fixed oils, develops heat. Considerable work has been done trying to explain the reaction between the oil and the acid under these conditions. Those interested will find this here and there in chemical literature. It is also clear that anything which affects the generation of heat or causes loss of heat will affect the result. The method of stirring affects the generation of heat. Beginners are apt to get results with the self-same oil and acid differing from 5 to 10 degrees, apparently due to lack of skill in securing an intimate mixture of the oil and acid by stirring. Even different experienced operators using the same materials frequently get results differing a degree or two. It is almost impossible to explain in words how to stir, but perhaps the words, "energetic," "rapid," and "thorough," in opposition to "sluggish," "slow," and "incomplete," best express the kind of stirring required. The length of time from the beginning of the operation to the final reading of the thermometer has an important influence on the result, apparently due to loss of heat during the operation. If the stirring is properly conducted, of course the length of time required is a function of the speed of reaction between the oil and acid, and this varies with different oils. With oils of which 20 cubic centimeters are used for test as is described above, the reaction with proper stirring should be complete, and the final reading made in from a minute to a minute and a half from the time the stirring begins. Loss of heat may also be occasioned by improper touching of the lower part of the beaker, by a draught of air, by conducting the test in too cold a room, and by using a beaker which has not been properly dried on the outside. Still further, the importance of having the oil to be tested free from moisture even in very minute amounts, will not escape attention, since the great heat developed by the mixing of oil of vitriol and water is so well known.

A number of experiments have been made looking toward diminishing the loss of heat by enclosing the beaker in some non-conducting medium, such as cotton wool. No valuable results have been obtained from these tests, apparently because when the test is properly conducted, the loss of heat during the required time is so small that it can be ignored. As would be expected, the appliances for surrounding the beaker with non-conducting material complicate the manipulation somewhat.

As has been stated, the energy of the action of the acid on the oil varies with the kind of oil. With the non-drying oils, such as olive, lard, neatsfoot, tallow, etc., action is slower. With the semi-drying oils, such as cottonseed, it is more rapid, while with the drying oils, such as linseed, poppy, and some of the fish oils, it is still more rapid and energetic. Also the rise in temperature characteristic of the various kinds of oil seems to follow the same law, as the energy of the action, viz., the non-drying oils give the lowest rise in temperature, while the drying oils give highest. Another interesting observation in this connection is that with all oils, so far as our observation goes, when the temperature reaches somewhere from 200 to 220 degrees F., and with some oils below these temperatures, a new reaction begins, resulting in the disintegration of sulphurous acid (SO₂). This interferes with the test by frequently causing the material to foam up and run over the beaker. It is, accordingly, necessary when testing such oils as give high figures to use less of them for test. The method described above applies in amount of oil taken for test, to the non-drying oils. When testing the drying oils, or such as give a high rise in temperature, use 5 cubic centimeters of the oil instead of 20, as with the non-drying oils. The other items of the test are alike in both cases, except that in calculating percentages figures obtained when using 20 cubic centimeters of an oil cannot be used with figures obtained when using 5 cubic centi-

meters of the second oil. It is obvious that when calculating percentages the figures used must be obtained from each of the oils under the same conditions in every respect.

It is clear that when several oils give figures nearly alike, as is the case with olive, lard, tallow oil, etc., the certainty with which information as to the purity of these oils can be obtained by means of Maumené's test is diminished. For example, it would be practically impossible by means of this test alone to say whether a sample of so called olive oil was mixed with tallow oil or not, since the rise in temperature characteristic of these two oils is so nearly alike. On the other hand if a sample of so called olive oil was in reality a mixture of olive oil and cottonseed oil, it would be easy by means of this test to say that the so called olive was not pure olive oil, since cottonseed oil gives so much higher rise in temperature than olive. Still further, it is obvious that the constituents of a mixture being known, the percentages in the mixture are much less accurately calculated if the two constituents give figures for rise in temperature nearly the same than if these figures are wide apart.

While Maumené's test does give some considerable help in identifying the kind of an oil which one may have in hand, provided that oil is pure, it should be clearly understood that it throws very little if any light on the identity of the oils in a mixture. And it will not escape notice that by proper mixtures the characteristic rise in temperature of many oils may be very closely approximated. For example, a mixture of some of the refined petroleum, which give almost no rise in temperature under Maumené's test, and cottonseed oil, might be made of such proportions as would make the mixture give the rise in temperature characteristic of olive oil. Fortunately for those who have to do with checking the adulterations and sophistications of the market, Maumené's test is not the only one that can be used in such cases. Fortunately, also, for those who have to do with not only the testing of oils, but also the practical use of them, the fixed animal and vegetable oils which are most valuable for lubrication and burning at the present time, give with Maumené's test figures which are near the lower end of the series, while the fixed animal and vegetable oils which can commercially be used as adulterants of these at the present time give figures much higher up in the series. Also the most successful drying oils give figures very high in the series, while a portion at least of the adulterants of these give figures considerably lower down, so that while the indications of Maumené's test, as has already been stated, cannot be regarded as final in regard to any oil, it still does give much very valuable information.

It will be evident from what has preceded that figures obtained by any operator while using Maumené's test are a function not only of the acid, the thermometer and the beaker employed, but also in some degree of the operator and the surroundings. Still further, our experience indicates that even with pure oils of any kind the figures are affected by the previous history and quality of the sample. Old oils do not give exactly the same figures as fresh ones, an inferior grade of an oil does not give exactly the same figures as a better grade, a pure oil consisting principally of olein does not give exactly the same figures as one containing considerable stearin along with the olein. In view of these facts a list of the figures characteristic of various oils is not of very great value. It may be said, however, as a general guide, that pure winter strained lard oil of the best grade made from the fat of corn fed animals should, when tested as above described, show a rise in temperature of from 78 to 80 degrees F., while pure raw linseed oil, properly settled and free from the oil of other seeds, should, using 5 cubic centimeters for a test, show a rise in temperature of from 105 to 106 degrees F. These figures should only be taken as a general guide. The only safe plan for an operator using Maumené's test to follow is to provide himself with samples of the various oils he may be called upon to test, which he knows to be pure and of the proper grade and previous history, and to constantly use these oils as a check in his daily work. The obtaining of such samples is not always easy, but they seem to be an essential, and if we may trust our experience, it is worth the expenditure of considerable energy to secure them.

That "semi steel" is really not steel at all but toughened cast iron is the claim made by Mr. A. E. Outerbridge in regard to the alloy that is used to some extent in the manufacture of M. C. B. couplers. "Semi steel" is the result of mixing steel scrap with pig iron in a cupola and, according to Mr. Outerbridge, the identity of the steel is entirely lost and that of the cast iron completely preserved, the resultant metal being simply a strong close grain cast iron. The statements have not yet been challenged.

RECONSTRUCTING LOCOMOTIVES.

By Francis R. F. Brown.

The advantages of reconstructing or modernizing locomotives are now becoming so generally recognized, and appear to be, deservedly, growing so much in favor, that a few words on application and results obtained, may be of use to some of the readers of the "American Engineer." Every railroad owns some old or obsolete locomotives. The wealthier roads can afford to dispose of these and purchase or build modern machines, but to the majority of roads the question of reconstruction might be well worth consideration.

Locomotives from fifteen to twenty years old may, generally speaking, be reconstructed, the chief parts for renewal being the boilers and the cylinders. The boilers, because eighteen years may be considered a fair average life for them; during this life the fire box will not only have been frequently patched, but it will have been renewed once, or more than once, and boilers as built eighteen years ago were made of iron and the plates were what are now considered to be too light, they were also small in size, and carried a low pressure of about 135 to 140 pounds per square inch. The new boilers might be of the extended wagon top type, and of as large size as the frames and axles will permit; the boiler pressure should be from 160 to 180 pounds per square inch, according to circumstances.

The cylinders should be renewed, because twenty years or so ago the independent saddle type of cylinder was largely used, they were born with a disease to develop sooner or later—generally sooner—viz.: "loose cylinders;" the older they grew the worse became the disease, and the cure for the disease is the application of the half saddle type. The new cylinders should be either of reduced size or, at the most, of the same size as the old ones, which circumstances, such as strength of frames, and motion, size of axles, etc., will govern; because, generally speaking, till recent years all locomotives were more or less over-cylindered. The new cylinders should be provided with ample steam and exhaust ports and passages, and the valves should be of a modern balanced type.

The frames should be strengthened by reinforcing the splice, and main panel, and adding cross braces and a strong and heavy back casting well secured. Cast iron running boards, stronger crank pins, and solid end, fluted side rods should be adopted. For an illustration of how frames may be strengthened see "National Car and Locomotive Builder" for March, 1895.

By this process of reconstruction a new life may be given to the locomotive, and its haulage capacity increased from 15 up to 35 per cent., and the cost of the work is such as to recommend it for careful consideration.

An eight-wheeled road engine, of about 1880 and later date, with 16 or 17 inch cylinders, may be reconstructed on the lines as outlined above for about \$3,250 to \$3,600, and an 18 inch engine of the same type for a sum not exceeding from \$3,750 to \$4,200—these amounts including the necessary heavy repairs resulting from such reconstruction.

As one example of reconstructing passenger engines of the eight-wheel type, I will cite the following: The original locomotive for our notice had 18 by 24 inch cylinders; driving wheels 69 inches in diameter; boiler with 52 inch shell of the old wagon top style; pressure 140 pounds per square inch; total weight in working order was about 85,000 pounds, the frames were light, the axles 8 inches in diameter, and the cylinders of the old independent saddle type, with its characteristic defects. In reconstruction the frames, wheels, tires, axles, and motion were used again; and new boiler, cylinders, springs, spring-gear, crank pins and side rods were supplied.

In deciding upon the size of the boiler and the cylinder proportions, the strength of the frames and size of axles received careful consideration. The boiler adopted was of the "Bel-

paire" type, with 56 inch shell and a working pressure of 180 pounds to the square inch, and still bearing the light frames in view, the cylinders were made 17 by 24 inches, and of the half saddle type. Balanced valves of the "American" type were put in. The engine as reconstructed weighed 110,500 pounds in working order, of which 36,500 pounds were on the truck and 74,000 pounds on the drivers. The gain in tractive power was about 35 per cent. Several locomotives were thus reconstructed, and after being in operation for about three years, on a mileage of 378,100 miles, the cost of maintenance for running repairs was \$6,261.38, or about 1.65 cents per mile. In fuel consumption, when running against the original engine with 18 by 24 inch cylinders, and on the same trains, and with the same number of coaches, it was found that the reconstructed engine ran an average of 36 miles to a ton of coal, as against 31 $\frac{3}{4}$ miles run by the original engine to a ton of coal, showing a saving of 13 per cent. in fuel in favor of the reconstructed engine, while on a heavier train they were demonstrated to make better time with 8 coaches, than the original engine could do with 6 coaches.

The question of reconstruction is one to which the mechanical officers of roads which have not much money to spend on new locomotives may well devote some of their time and experience. To roads not possessing modern equipped boiler shops, there are always the locomotive building establishments, from which new boilers and cylinders, side rods, etc., of modern design and make may be procured at reasonable rates, and the moderate expenditure involved in reconstruction should recommend itself to the favorable consideration of "The Management," always providing that the management has advanced beyond the stage of believing that the weight of train to be hauled depends upon the inches of the cylinder, and of insisting on a cylinder larger than is necessary or advisable to accompany the larger boiler, and thereby defeating the object of increased haulage power, combined with a decreased fuel consumption and cost of maintenance, and causing a repetition of the old defect, an over-cylindere engine, with the added drawback of light frames, and running gear, which were the bones of the original locomotive.

SAMUEL ROGER CALLAWAY.

The New York Central & Hudson River Railroad, in calling Mr. Callaway to its Presidency, has made a most wise and fitting selection.

He began his railroad career at the age of thirteen, as an indentured apprentice office boy in the office of the Treasurer of the Grand Trunk Railway of Canada, and it is interesting to know that his first year's salary amounted to \$100. At the age of nineteen he was a clerk in the office of the Great Western Railway at London, Ontario, from which he was promoted to the position of train master and private secretary to the General Manager. In 1874 he came to the United States as Super-

intendent of the Detroit & Milwaukee Railway, and four years later he accepted a similar position with the Detroit, Saginaw & Bay City Railroad. He was General Manager of the Grand Trunk lines west of the St. Clair River from 1881 to 1884, and at the same time held the office of President of the Chicago & Western Indiana Railroad. He was elected Vice-President and General Manager of the Union Pacific in 1884, and held the office for three years, retiring to take the presidency of the Toledo, St. Louis & Kansas City, and under his direction the company was reorganized and the road practically rebuilt. In January, 1895, he was elected President of the New York, Chicago & St. Louis, and in August, 1897, he was selected to succeed the late D. W. Caldwell as President of the Lake Shore & Michigan Southern Railway, and April 27, 1898, he was elected President of the New York Central & Hudson River Railroad.



Samuel Roger Callaway.

The attainments and experience of Mr. Callaway are such as to render the road subject to congratulations on the appointment, and surely no better opportunity could be offered him for the exercise of his abilities. His many friends will join the "American Engineer," to which he has been a subscriber for a number of years, in the hope that he will not end his career by overwork, as President Newell did, but that he will live many years to enjoy the fruits of his conscientious efforts.

Mr. John M. Toucey, General Manager of the New York Central & Hudson River Railroad, has resigned and will retire from active railroad work to enjoy a well earned rest. He is 70 years of age and entered the service of the Naugatuck Railroad as station agent about 50 years ago. He went to the Hudson River road in 1855, and in 1862 was appointed Assistant Superintendent. From 1867 to 1881 he was Superintendent of the Hudson River Division of the New York Central Railroad, and from 1881 to 1890 was General Superintendent of the entire system. He was appointed General Manager in 1890, and has held the office continuously since.

The Young Men's Christian Association of Dunkirk, N. Y., is the recipient of a generous gift in the form of the Brooks homestead, in Dunkirk, valued at about \$90,000. The property was given by the heirs of the late Horatio G. Brooks, the founder of the Brooks Locomotive Works, and it is to be used as hospital, library, educational and recreation purposes by the association.

The Carlisle Manufacturing Company's plant at Carlisle, Pa., which has been idle for several years, has been bought by Philadelphians, and will be equipped with new machinery. In addition to frog, switch and metallic tie work, projectiles will be made for the Government.

The Cramp Ship Building Company recently closed a contract with the Russian Government for the building of a heavy armored battleship of 12,500 tons displacement and a speed of 18 knots per hour, to be sustained for a trial of 12 hours, and for an armored cruiser for 23 knots speed and 6,100 tons displacement. These will be the first Russian war vessels to be built at any foreign shipyard.

OUR DIRECTORY

OF OFFICIAL CHANGES IN MAY.

Baltimore & Lehigh.—Mr. G. W. Seidl has been appointed Master Mechanic, with headquarters at Baltimore. The office of General Foreman of Locomotive Repairs has been abolished.

Brockville, Westport & Sault Ste. Marie.—At a meeting of the Directors, recently held in Brockville, Ont., Mr. James G. Leiper resigned as President and was succeeded by Mr. Evans R. Dick, of 310 Chestnut street, Philadelphia, Pa.

Chattanooga Southern.—Mr. E. H. Harding has been appointed Master Mechanic, with office at Chattanooga, Tenn., succeeding Mr. J. H. McGill, resigned.

Chicago, Burlington & Quincy.—Mr. N. E. Jennison has been appointed Assistant Purchasing Agent, with office in Chicago, succeeding Mr. George G. Yeomans, promoted.

Chicago & South Bend.—Mr. C. L. Milhouse has been appointed General Manager, with office in South Bend, Ind., succeeding Mr. C. W. Stover.

Cincinnati, Portsmouth & Virginia.—Mr. Evans R. Dick has been elected Vice-President, with office at Philadelphia, Pa., vice Mr. James G. Leiper, resigned.

Detroit & Lima Northern.—Mr. J. R. Hawkins is General Superintendent, with office at Detroit, Mich. The office of Mr. C. H. Roser, Chief Engineer and Purchasing Agent, is now at Detroit. Mr. J. W. Stokes has been appointed Master Mechanic, with headquarters at Tecumseh, Mich.

Flint & Pere Marquette.—Mr. W. B. Sears, formerly Chief Engineer, has had his title changed to that of Consulting Engineer, his headquarters remaining at Saginaw, Mich. Mr. G. M. Brown, heretofore Superintendent of Roadway and Structures, has been made Engineer in charge of bridges, culverts, buildings, interlocking, new construction and standards of maintenance, with office at Saginaw. Mr. E. Treadwell has been made General Roadmaster, in charge of maintenance of roadway, with office at Saginaw. Mr. H. E. Moeller, heretofore Assistant Passenger Agent, has been appointed General Passenger Agent. Mr. A. H. Hawgood has resigned his position as Superintendent of Steamships at Saginaw.

Georgia & Alabama.—The headquarters of Chief Engineer C. P. Hammond, at Meldrim, Ga., has been transferred to Savannah.

Georgia.—Mr. Charles H. Phinzy, formerly President of this road, died at Augusta, Ga., April 28, at the age of 63 years.

Great Northern.—Mr. Louis W. Hill has been appointed Assistant to the President, with office at St. Paul, Minn.

Green Bay, Winona & St. Paul.—Mr. Timothy Case, formerly General Superintendent of this road, died suddenly in Chicago May 9, at the age of 75.

Intercolonial.—Mr. G. R. Joughins has been appointed mechanical Superintendent, vice Mr. F. R. F. Brown, resigned.

Lake Erie & Detroit River.—Mr. Owen McKay has been appointed Engineer, succeeding the late Chief Engineer Joseph DeGurse, whose death occurred on March 22.

Lake Shore & Michigan Southern.—Mr. Addison Hills, Assistant to the President, died at his residence in Cleveland, Ohio, May 7, of pneumonia, at the age of 91 years.

Maricopa, Phoenix & Salt River Valley.—Mr. B. F. Porter has been appointed General Superintendent, with headquarters at Phoenix, Ariz. He was formerly Acting Superintendent.

Minneapolis, St. Paul & Sault Ste. Marie.—Capt. Watson W. Rich, formerly Chief Inspector of this road, has been appointed Consulting Engineer. Mr. John F. Shaughnessey has been appointed Purchasing Agent, with headquarters at Minneapolis, Minn., in place of Mr. T. A. Switz, resigned.

Mobile & Ohio.—Mr. J. J. Thomas, Jr., has been appointed Master Mechanic of the Montgomery Division, with office at Tuscaloosa, Ala.

New York Central & Hudson River Railroad.—Mr. H. J. Hayden, Second Vice-President, will hereafter represent the N. Y. C. & H. R. R. and its allied lines on the Board of Managers of the Joint Traffic Association. Mr. H. Walter Webb having resigned, owing to ill health, the office of Third Vice-President is abolished. The office of General Manager is discontinued, Mr. J. M. Toucey having resigned. Mr. Nathan Guilford, General Freight Traffic Manager, will have general supervision of all freight traffic, and Mr. George H. Daniels, General Passenger Agent, of all passenger traffic, reporting direct to the President. The General Superintendent, Chief Engineer, Superintendent of Motive Power and Rolling Stock, and the Purchasing Agent will hereafter report to the President direct.

New York, Chicago & St. Louis.—Mr. William H. Canniff has been elected as President of this road, succeeding Mr. Samuel R. Callaway, who has been made President of the New York Central & Hudson River.

New York, New Haven & Hartford.—Mr. W. E. Chamberlain has been appointed General Superintendent of the Old Colony system, succeeding Mr. E. G. Allen, resigned.

Norfolk & Western.—Mr. Jos. Longstreth has resigned as Road Foreman of Engines to accept a position as Master Mechanic of the Schoen Pressed Steel Co., of Pittsburg, Pa.

Ohio River & Charleston.—Mr. Simon Davis has been elected Vice-President, succeeding Mr. Job H. Jackson.

Panama.—Mr. F. S. Higbid has been appointed Assistant Engineer. He was formerly Roadmaster of the New York division of the Erie.

Panama.—Mr. Percy Webb has been appointed Master Mechanic, with office at Colon, Colombia, vice Mr. D. G. Mott, deceased.

Pennsylvania.—Mr. Daniel S. Newhall, heretofore Assistant Secretary, has been appointed Purchasing Agent.

Pittsburgh, Chartiers & Youghiogeny.—Mr. Jos. Wood has been elected President, vice Mr. E. B. Taylor, elected Vice-President.

Richmond & Petersburg.—Mr. Frederick R. Scott, President of this road, died at his home in Richmond, Va., Sunday, May 15.

Roaring Creek & Charleston and Roaring Creek & Belington.—Mr. Henry C. Terry, formerly Vice-President and General Solicitor, has been elected President, succeeding Mr. S. P. Diller. Mr. E. P. Rease is General Superintendent, with office at Belington, W. Va. Mr. Thomas Fisher has been appointed General Manager, with office in Philadelphia, succeeding Mr. O. W. Womelsdorf.

Sierra Ry of California.—Mr. H. J. Crocker has been elected Vice-President, with office at San Francisco, Cal.; Mr. S. D. Freshman continuing in his office of Treasurer as heretofore.

Sioux City & Northern.—At the annual meeting held in Sioux City, Ia., May 11, Mr. Samuel J. Beals was elected President. Mr. Craig L. Wright was elected Vice-President, and Mr. Howard S. Baker, Secretary and Treasurer, all of Sioux City, Ia.

Tecumseh.—Mr. J. W. Lewis is General Manager of this road.

Wabash.—The jurisdiction of Assistant Master Mechanic Hollingshead, of the Wabash, with headquarters at Ashley, has been extended over the car department.

Washington & Columbia River.—Mr. C. S. Mellen has been elected President.

White River, Lonoke & Western.—Mr. J. N. Wooley, of Wooley, Ark., was recently elected General Manager, and Mr. Dan Daniel, heretofore Secretary, was elected Vice-President. The general office is at Lonoke, Ark.

Wiscasset & Quebec.—Mr. G. P. Farley has been appointed General Manager, with office at Wiscasset, Me., vice Mr. W. F. P. Fogg.

WANTED.

Mechanical draughtsman with some practical experience, by car-building company. State age, experience, and salary expected. Prefer young man, and one willing to make himself generally useful. Address, DRAUGHTSMAN, care American Engineer.

Salesman to sell lubricating oils from samples, on commission. Liberal terms. THE EUCLID OIL COMPANY, Cleveland, O.

AMERICAN
ENGINEER
CAR BUILDER AND RAILROAD JOURNAL.

JULY, 1898.

CONTENTS.

ILLUSTRATED ARTICLES:		MISCELLANEOUS ARTICLES:	
Valve Motion—Baldwin Steam Motor Car ..	233	Air Motor, Metropolitan Street Railway, New York	235
New Machine Tools, The Niles Tool Works ..	235	Engineering Notes	237
Pneumatic Tools, Chicago Pneumatic Tool Co.	238	Regulation of Compound Wound Dynamios	239
Passenger Locomotive Truck, J. G. Brill Co.	240	Steel Car Framing	247
Rust from Salt Water Drippings. Springs for Freight Car Trucks ..	246	Care of Journal Boxes	247
Passenger Car Pedestal and Journal Box ..	248	Thermal Tests for Car Wheels ..	249
Boiler and Cylinder Insulation ..	252	Best Form of Cylinder Fastenings	250
MISCELLANEOUS ARTICLES:		Efficiency of High Pressure Steam	
Master Car Builders' Association Convention, Report of ..	219	The Apprentice Boy	251
Master Mechanics' Association Convention, Report of ..	223	EDITORIALS:	
Wide Range of Compressed Air ..	233	A Good Committee Report	236
Acceleration of Trains ..	233	Important Subjects for M. C. B. Association	236
Personal Items ..	234	Discussion on Steel Cars	236
		The Apprentice Problem	236
		Boiler and Steam Pipe Lagging ..	237

THIRTY-SECOND ANNUAL CONVENTION OF THE MASTER CAR BUILDERS' ASSOCIATION.

The convention was called to order at Saratoga Springs, N. Y., at 10 a. m., June 15, by President S. A. Crone, and was opened by prayer by Bishop Newman. The address of welcome was by Mr. A. P. Knapp, President of the village of Saratoga. This was the sixth visit of the Association in convention at Saratoga, and the welcome of former occasions was pleasantly renewed.

The Hon. Ashley W. Cole, of the New York Board of Railroad Commissioners, presented an address, in which the work of the Association in advancing safety and celerity of railroad travel received exceedingly favorable comment. The numbers of employees killed and injured in coupling cars had been reduced materially in recent years, which was due to the progress in applying safety devices to the cars. The speaker gave statistics showing the State of New York to be well advanced in their application; 74 per cent. of the cars on the lines within the State already had automatic couplers, and 40 per cent. had air brakes. The great service of the railroads in the present war was commented upon, comparison being drawn between the conditions of military transportation of the civil war and the vastly improved service of the present, which was exceedingly favorable to the Association, whose work had contributed largely to the improved conditions.

Mr. J. H. McConnell, in his reply to Col. Cole, sketched the progress of car building during the life of the Association, commenting upon the increase in capacities of cars and the reducing ratio of dead to live weight, the progress being such as to cause wonder as to what was to be done in the future. The comparison was aided by statistics and figures, with which Mr. McConnell is always abundantly supplied.

The Presidential address by Mr. Crone contained a number of suggestions of important matters which he desired to have the convention consider. It seemed advantageous to change the time of opening the convention to Wednesday morning, with a view of saving time to the members by reducing the interval between the master car builders' and the master mechanics' conventions. He considered the present limits of the height of drawbars of cars entirely too narrow, and would like to see the law changed to cover wider limits, to make the maximum height at least 35½ inches. The Association should take action with regard to a standard test of couplers, as had

already been done with wheels and axles, and the rules for loading lumber should be supplemented with others for loading stone and rails. Dummy couplings for air brake hose had often been the subject of discussion, and he would like to see the use of this device removed from the "recommended practice" of the Association. More attention should be given to the adjustment of air brake apparatus, and he hoped to see this subject considered seriously. Efforts to reduce the labor and expense of auditing bills for repairs of cars in interchange were commendable, and standard sizes for bill blanks were desirable. The discussion on present difficulties with regard to wrong repairs of cars, was anticipated, and the solution was to hold intermediate roads responsible for such repairs by the proper use of repair cards. The Association had accomplished a great deal, but "progress" was the word for the future, and in leaving the Presidency the speaker urged the necessity of renewed efforts to fulfill the promises embodied in the traditions of the Association.

Mr. Andrews was called upon and responded briefly and humorously. The minutes of the 1897 convention were approved as printed. The report of the Secretary showed a net increase of seven active members and eight new roads represented. The present membership was 457—263 active, 189 representative and 5 associate members; and the bills of the Association had all been paid up to date.

The report of the Treasurer, Mr. G. W. Demarest, showed a balance of cash on hand of \$8,245.61. In view of the funds on hand the Executive Committee recommended that the dues for next year should be reduced to \$4 per vote, which was carried by vote of the Association. Messrs. W. D. Crosman and E. A. Phillips were then admitted to associate membership.

COMMITTEE REPORTS AND DISCUSSION.

Supervision of Standards and Recommended Practice.—This report suggested a number of minor changes in the standards to remedy the inconsistencies and faults in the drawings which had developed in practice, and included the removal of the dummy coupling from recommended practice of the Association. The committee also recommended that the following subjects be referred to special committees for investigation and report to the convention of 1899:

1. Improvement and perfection of standard top hinged lid, so that it may more completely exclude dust from the journal box.
2. To recommend forms of standard journal boxes for 3¼ by 7 inch and 4¼ by 8 inch journals, adapted for use with the pedestal type of freight car truck.
3. M. C. B. automatic couplers. To define length and spread of guard arm, and also consider the devising of a safety limit gage for determining when M. C. B. couplers and knuckles are worn beyond the limit of safety.
4. To revise the recommended practice for loading poles, logs and bark on cars.
5. Specifications for M. C. B. coupler tests.

In the discussion Mr. Higgins suggested the importance of specifying the location of the air brake defect card, and was supported by several who thought it important to insure uniformity of attachment so that repairers would know where to look for the cards. This was referred to the Committee on Standards. All of the recommendations of the report were adopted and the question of changing the standards will be referred to the membership by letter ballot.

Triple Valve Tests.—Mr. G. W. Rhodes reported that there had been no triple valves submitted for test during the year, and the fact was deplored. Triple valves were being introduced which had not been subjected to test, and the committee had considered the advisability of requesting its discontinuance rather than exist as a useless figurehead. The examination and testing of new triple valves in the future was to be important, and they should all be brought before the committee before being introduced in service. The plea for better treatment of this important matter was exceedingly able and effective. Mr. Waitt indorsed the expression of the committee, and urged action by the association looking to the indorsement of

devices which had been favorably passed upon by the committee, and no others, the moral effect of which would be to prevent the use of the cheapest devices on new cars merely on account of their being cheap. Mr. Mitchell moved to instruct the committee to obtain triple valves of all the different makes for test, and report next year. Mr. Leeds questioned whether the present triple valve tests, which were based on the best possible service, were not unnecessarily rigid. Mr. Humphrey amended the motion providing for the submission of the report to the Executive Committee, with a view of distributing the report to the members as soon as ready, and before the convention of next year. The object was to render the results of the tests available for the members as early as possible. Carried.

NOON HOUR DISCUSSIONS.

Lumber Specifications for Freight Cars.—Opened by Mr. Pulaski Leeds. Much attention was paid to the quality of lumber used and the inspection thereof. Mr. Leeds said in part:

In my opinion one size of sill is proper for any of this class of car, and as a 4 by 10 will give all the strength necessary for compression and for carrying between bearings, the principal point is to guard against the tendency to break over the transoms.

All siding and lining should be $3\frac{1}{4}$ inches face, as this can be got out from the commercial widths of four inches, and will give no trouble by shrinkage, and further is capable of being securely fastened with a reasonable number of nails. The making of siding and lining uniform enables us to use our material to better advantage, the best for siding, and inferior grade for lining. Roofing is, in my opinion, most economically worked and laid from 6-inch strips, giving a face of $5\frac{1}{4}$ inches, two nails to a crossing.

In my opinion first class yellow poplar is not only the best substitute for white pine, but fully equal, as there is nothing, so far as my observation goes, that will hold paint as well, and it also holds the nail fairly well. Many of us have to use hard pine on account of excessive cost of white pine or yellow poplar, but it is not a good substitute, where they can be obtained at a reasonable advance in cost. The argument advanced in favor of steel versus cast iron, etc., of dead weight, will apply fully to this matter of siding, and I know of nothing that is a substitute for white pine or yellow poplar where they can be obtained at a reasonable cost.

I hope there will be a discussion of the subject of standard dimensions not only as advanced, but the desirability of standard dimensions for all material constituting the framing of a car. If we could get widths and thickness uniform, the length would not be so essential, although desirable. In my opinion, all cars of certain classes should be uniformly framed; not only would we get the benefit in repairs of foreign cars without delay, but when specifications were issued (as they frequently are) calling for all lumber and timber to be seasoned on the stick for at least six months, although calling for a delivery within sixty days, they will not be so apt to call up a derisive smile, inasmuch as manufacturers could then not only stock up for seasoning and take advantage of the market, but they could well afford to build such standard cars in stock, and when offered a contract in which the delivery was the essence of such contract, would only have to letter well-seasoned cars, instead of having to pick the buds and leaves off such "seasoned" timber as will persist in growing while in process of construction into cars for prompt delivery.

The subject of standards on cars was the first point brought up and the desirability of standard dimensions was shown as it has been repeatedly for years. Mr. Higgins spoke favorably of Norway pine for siding and lining; he had had good results with it. Mr. Hennessey reported favorably on Douglas fir for sidings and roofing. Mr. Appleyard spoke approvingly of it for passenger car floors.

M. C. B. Journal Boxes, Wedges, Brasses and Lids.—Mr. H. F. Ball directed attention to the importance of providing an adjustable bearing for the brasses, to maintain a uniform distribution of the load lengthwise of the journal bearing. [See American Engineer, May, 1898, page 158.—Editor.] There was no discussion.

Air Testing Plants for Terminals.—Mr. H. F. Ball opened the discussion with a description of the new plant in the yards of the Lake Shore, near Buffalo, which was installed for about 15 cents per running foot, exclusive of compressor. Mr. S. P. Bush said that the bad condition of the brakes on many cars

demanding comprehensive air brake testing plants. He had recently become convinced as to this by investigations into the conditions of brakes of cars received upon his road.

Standard Trucks.—Mr. E. D. Bronner introduced the subject which had often been up for discussion from the earliest days of the Association. He did not consider it desirable to attempt to standardize to a much greater extent than had already been done, owing to the fact that progress in improvements would be seriously retarded and difficulties would always be found in getting people to adhere to standards if adopted. The most common parts were all that could be satisfactorily standardized. The plate truck was believed to be the best type for heavy cars, and had much to recommend it over the diamond type.

COMMITTEE REPORTS.

Standard Wheel and Track Gages.—This committee presented a verbal report, stating that owing to the illness of the chairman, they had as yet made no tests and that the committee would make tests and present the results next year.

Brake Shoe Tests.—Mr. Bush stated that no tests had been made during the year and that the testing apparatus had been transferred from the works of the Westinghouse Air Brake Co. to the laboratory of Purdue University, the conditions of the transfer to be printed in the proceedings.

Rust from Salt Water Drippings.—Mr. Gibbs raised the question concerning the damage to bridges which would not be protected by the use of a tank and pipes to lead and discharge the brine at the center of the track. Mr. Higgins answered by stating that the bridges could be protected by paint and sheathing. On Mr. Waitt's suggestion a motion was made, and carried, to refer the report to letter ballot for recommended practice; this to be confined to the device shown by the committee, upon which a patent had not been sought.

SECOND SESSION.

The first business of the second session was a consideration of the report of the committee on conference with Auditors, which had been referred to the arbitration committee. The committee recommended the adoption of the report, and its transmission to the Railway Accountants' Association, with the statement that the M. C. B. Association is in sympathy with the general intent of the report, but that it did not consider itself competent to act upon the first three recommendations.

Trains Parting.—There was no report by this committee, which fact Mr. G. W. Rhodes thought was greatly to be regretted, as there was hardly a more important subject to be dealt with by the railroads. Much discussion had been held in the railroad clubs concerning the parting of trains, and a blind confidence that some one was looking after the character of the couplers seemed to prevail in the association. Though the C., B. & Q. R. R. had comparatively few accidents, the most frequent cause of those that occurred was the break-in-two. The action of one of the coupler manufacturers in the reduction of the price of couplers to a point which discouraged new companies from taking the field was commended, and also that by which the manufacturers agreed to receive any scrap material made in the form of an M. C. B. coupler. The latter practice would tend to expose those who are using inferior material, which some of the newer companies are attempting to introduce. He had even found couplers in service made of cast iron, which material was used not only for the knuckle, but for the body of the coupler itself. In case of accident with loss of life, a road putting such stuff into service was committing a criminal act, and the discovery of any such material upon the equipment of cars passing over the speaker's road should have all possible prominence. Specifications for couplers were necessary, and further than that, it was desirable that record should be kept of all break-in-twos, whereby their causes might be traced, and the difficulties removed when discovered, to the end that the couplers causing break-in-twos may be known and information may be had as to the best

material and best form of attachments. The increasing speed of trains and dangers involved therein rendered it necessary to spare no effort to provide safety.

Mr. A. M. Waitt supported Mr. Rhodes, and stated that by keeping records of failures he had been able to understand and remove a number of the causes thereof. Couplers were important enough to require the attention of a standing committee to take up the question of break-in-twos, the preparation of specifications, and the consideration of limits to the permissible wear in the couplers. There would be much for such a committee to do in the testing of new couplers, and in keeping statistics of failures. He remarked incidentally that the constant motion of the cars approaching and separating from each other on the road appeared to demand the use of buffers. The contour lines needed to be maintained, in proof of which he exhibited a blue print of a coupler, which showed that, on account of wear and the distortion of a guard arm, the bending between the knuckle and the guard arm was more than one inch, which was enough to permit the coupler to uncouple repeatedly on the road, without the lock being raised. He concluded that the amount of distortion or bending of the guard arm, and the change in the position in the knuckle, due to wear, and the thinness of the tongue, due to wear, as well as the wear of the knuckle pivot, should be limited. Gauges used by the speaker were exhibited.

Revision of Interchange Rules.

The recommendations of the Arbitration Committee had been so thoroughly threshed over in advance as to leave comparatively few matters requiring discussion, the chief of which were the adjustment of prices for repairs to cars east and west of the 105th meridian, due to the difference in cost of labor and material in the two sections of the country. The western members fought hard for a differential rate of 15 per cent. added to the labor and material charges for work done by them, to save them from the loss occasioned by the difference in the schedules. Messrs. McConnell, Humphrey, Hickey, Schlack, Dunn and Small did the talking in favor of the change, and it was shown that the labor charges west of the Missouri River were nearly 31 per cent. greater than on the eastern lines. The cost for material was from 10 to 15 per cent. higher in the West. On the other hand, according to figures given by Mr. McConnell, the mileage of Union Pacific cars on foreign lines was 41,222,483 miles, the mileage of foreign cars on the Union Pacific being 79,537,917. The Union Pacific paid out for foreign mileage \$508,942, and collected for mileage on Union Pacific cars on foreign roads \$248,985; these figures covering the amounts paid in the two accounts during the same time.

Mr. Bush presented an argument to show that the mileage rate paid for cars was so low as to constitute a rental which gave an advantage to the western lines, which was in part as follows:

We have an average mileage rate for ordinary freight cars which covers the entire country. That rate is six mills per mile. It is very low. The average value of a car is \$400. The interest on that is \$24. The average mileage of freight cars on 23 of the principal roads of the United States is 21 miles per day. That gives a mileage of 7,560 miles a year. The return rate of six mills per mile is \$45.36 to the owner. Out of that he has to pay for the cost of maintenance, and included in that cost is the item of depreciation, and the renewal of cars worn out. At the very lowest four mills per mile will not cover the cost, and it will reach over five mills, as the cost of maintaining, including renewals, cars being destroyed, etc. Now assuming that it is over four mills for maintenance, that will mean \$30.24 per car per year. Admitting that the revenue received from the car is \$45, you have \$15 as the return on your investment. The railroads west of the 105th meridian are getting the benefit of that exceedingly low mileage rate. As Mr. McConnell showed by his figures, they are using more foreign cars than the mileage of their cars on eastern roads, and his road and all the others in that section of the country are getting the benefit of that exceedingly low mileage rate, which I claim compensates them for any difference in the cost of making repairs, but even if it did not

they would have to take their own equipment to do the business they are doing to-day with foreign cars. They would pay exactly the same amount of money and more to maintain their own equipment than they are paying to-day. In addition to that they could not get a fair return on their investment. The fact of the matter is, I believe the western roads are ahead on account of being able to rent cars at a low mileage rate. I cannot bring myself to believe that it is any way just to make this differential rate.

The discussion not being completed, the session adjourned to meet in the afternoon and was resumed by Mr. H. J. Small, who took the position that the matter should be settled by the association without considering the car mileage, which involved questions outside of the province of the association to decide.

Mr. Humphrey at this point gave an abrupt turn to the course of the discussion by waiving the differential on charges made to railroads, and in place of the motion which was made last year, he substituted one providing the application of the differential of 15 per cent. to be added to the cost of all repairs done west of the 105th meridian on cars not owned or operated by railroad companies. This was in effect, as was stated by one of the speakers, an attempt to waive the question of differentials against the railroads who could practice reciprocity with the western lines, and to get even in the matter by adding the cost to the private car lines who could not reciprocate.

Mr. Rhodes here made a most sensible suggestion by showing that this was a matter of great importance, which was not to be decided without deliberation and consultation with superior officers. The question was complicated and the single question of whether a differential was advisable was enough for one committee to tackle. He turned the whole tide of discussion, which from this point assumed a more reasonable, rational aspect, and immediately a number of the representatives of private car lines expressed their opinion of the motion, which was unfair to them in view of the fact that they were urged to take up the interchange on account of the benefit which they would derive therefrom. The motion was voted down, whereupon Mr. Rhodes submitted one to the effect that the question of differentials and the charges under the rules should be referred to a committee of five, consisting of one railroad man from the East, one from the middle section and one from the West, with two representatives of the private car lines. Carried.

Among the other questions in regard to prices, a committee was appointed to suggest a blanket price for all couplers used in repairs, and this committee afterward suggested a price of \$7.50, which was adopted after considerable discussion. The object of this action was to remedy the present defect in the rules whereby the prices for couplers, as given to the Secretary of the association by the manufacturers, are sometimes double the market prices.

The passenger car prices were approved, and the session adjourned.

FOURTH SESSION.

The stenciling of light weights on cars was considered and placed among the committee subjects for next year.

Committee Reports.

Care of Journal Boxes.—Mr. Waitt considered a record of 2½ hot boxes per 1,000 miles an unnecessarily high one, for which there was no justification except in the most sandy sections. The Lake Shore hot box record was one hot box to 70,000 miles run in passenger service, and one to 20,000 miles in freight. Eighty per cent. of these were on foreign cars and 20 per cent. on home cars, the good record on home cars being due to insisting on knowing the causes for each case. It was necessary to exclude dust, and the common wooden dust guard was unsatisfactory, a good dust guard being worth experimenting and searching for. A good dust guard was probably to be had, and was very much needed. As to oils, summer oils should not be allowed to remain in the waste when winter oil was put in, the summer oil proving a "non-conductor" of winter oil. The

boxes should be repacked with waste soaked in winter oil. In winter many hot boxes resulted from moisture deposited in the boxes during a thaw following cold weather, and this moisture should be removed. It was worth while to remove packing from boxes when cars were undergoing repairs, and replace with good waste when they are turned out on the road.

Mr. F. W. Brazier—The plan of using saturated waste instead of oil, by inspectors, was a source of saving and prevented hot boxes.

Mr. Mendenhall defended the present wooden dust guard, but it should be a tight fit in the casting to exclude the dust.

Mr. Schroyer recommended thinning down the wheel hub and providing for a $\frac{3}{4}$ to $\frac{7}{8}$ inch guard; the wood should be thicker. He preferred cotton to woolen waste, as a better absorbent of oil.

Mr. Leeds touched on one of the chief reasons for hot boxes when he said that many of them were caused by using bearing material for the brasses that was not fit to be used on wheelbarrows.

Square Bolt Heads and Nuts: Standards for Pipe Fittings.—This subject requiring further work, the committee was continued until next year.

Specifications for Air Brake Hose.—The report by Mr. Waitt was so complete and thorough as to leave nothing to be said in discussion. The subject will be taken up again for report at the convention of 1900.

Springs for Freight Car Trucks.—No discussion.

Thermal Tests for Car Wheels.—No discussion.

Air Brake and Signal Instruction.—The report was accepted and ordered submitted to letter ballot. It presented a number of minor changes in the rules.

Steel Car Framing.—Mr. Mitchell explained that it had been impossible for the committee to make and recommendation, which was due to the fact that only about 12 per cent. of the members were prepared to express opinions on the subject. The report was received and the subject will be taken up again in about four years.

Mr. Simonds placed the saving in the length of trains among the most important recommendations of the large capacity steel cars. He desired to see the committee continued for report from year to year, and instructed to give early consideration to the designs of draft gears and body bolsters. With trains of 2,100 tons the pull on the draft gear was 35,000 pounds on a 22-foot grade, which was 9,000 pounds above its capacity, and necessitated new treatment in designing draft gear. This ended the discussion, which was exceedingly disappointing to those who wanted to learn something about steel cars.

Passenger Car Pedestal and Journal Box for Journals $4\frac{1}{4}$ by 8 Inches.—The recommendations of the committee were first corrected in several minor points and then ordered submitted to letter ballot.

Committee on Prices.—The adjustment of prices brought out considerable discussion with regard to couplers, the result being a change from the present rule (Section 11, Rule 5) to provide for a blanket price for all couplers or parts, based upon average current prices. The matter of prices was brought up in the second session by Mr. Tracy Lyon, who objected to the present system of charging more than the current market prices for couplers. The price for couplers for the coming year is to be \$7.50. Mr. J. J. Hennessey presented the arguments that carried this action through, and the credit for the result is largely due to him.

Notice was given of proposed changes in the by-laws, looking to the admission of Railroad Commissioners in the membership of the association, and to change the date of meeting to the second Wednesday instead of Tuesday in June. These changes will be acted upon next year.

The revision of the rules for loading lumber, rails and other long materials was brought up by Mr. Leeds. He presented a pamphlet giving the changes in the rules desired by the original committee, which was referred to a committee to revise the rules and confer with a similar committee of the American Railway Association.

TOPICAL DISCUSSION.

Side Bearings.—Mr. Mitchell had made tests comparing the drawbar pull on trains with side bearings in contact with

others which were clear of each other, the results showing clearly the advantage of using bolsters which will keep the side bearings clear of each other.

Air Brake Details for Freight Cars.—Mr. A. L. Humphrey urged the adoption of standards for the application of air brake equipment, before the apparatus had made too great progress to make this possible. Retaining valves on 1,500 cars had been examined and only 137 of these were found in working order. Some of them were placed on an angle, which prevented the valve from operating. Standards were needed to prevent too many joints in the train pipe, and the bends of the pipes should also be systematized. Much trouble was now experienced from poor material and workmanship.

Axles for 100,000 Pound Cars.—Mr. E. D. Nelson. The large number of 100,000 pound cars necessitated the adoption of a design for a standard, and a design was submitted with a suggestion that it receive consideration by the association, with a view of submitting the design to letter ballot for recommended practice. There was no discussion and no action on the suggestion.

Height of Drawbars.—Mr. C. A. Schroyer opened the discussion by stating that three inches did not give a sufficient leeway to provide for the variation in height of couplers, considering the fact that nearly all of the wear of the wheels, axles and busses, and also the shrinkage of timbers, tended to reduce the height of the cars. An increased allowance would involve no danger to trainmen, and was badly needed to provide for wear and for increasing loads. He recommended action by the association looking to an increase in the allowance to $4\frac{1}{2}$ inches from the present limit of 3 inches.

Mr. Rhodes suggested caution in this because increasing the limits would cause danger from the small amount of bearing surface left in the couplers. The result of the discussion was to order the Executive Committee to confer with the Interstate Commerce Commission.

Securing Running Boards to Car Roofs and Location of Ladders.—Mr. A. E. Mitchell described the malleable iron running board bracket manufactured by the Dayton Malleable Iron Co., and gave an excellent account of its four years of service on the Erie, during which time none had become loose. Mr. Mitchell considered the end ladder much safer than the side ladder, owing to liability of accident to trainmen on account of obstructions along the track.

Durability of Paint Sprayed by Compressed Air.—Mr. F. W. Brazier had investigated the relative condition of paint applied by air and by brush, which was invariably in favor of the air. The forcing of the paint into the surface of the wood by the impact of the jet was found to add to the durability of the paint. He gave records from the painters, and from his own observations was convinced that the air system gives better work, better service and is cheaper. A car painted and stenciled, including the track mark of the road, costs but \$3.00 for labor. Mr. J. E. Simonds corroborated the experience of Mr. Brazier.

The committee on subjects for next year reported as follows:

First—Standard specifications for lumber in freight car construction.

Second—Best design of freight car door-fasteners.

Third—Standard application of air-brake appliances with a view to reducing the number of couplings in pipes.

Fourth—Best method of applying running-boards and ladders to freight cars.

Fifth—Committee to report on the advisability of allowing a differential for fixing prices for repairs done on work west of the 105th meridian.

Sixth—Perfection of top-hinged oil-box lids, so as to more completely exclude dust from journal boxes.

Seventh—To recommend standard journal boxes $3\frac{3}{4}$ inches by 7 inches, and $4\frac{1}{4}$ inches by 8 inches, adapted to use with the pedestal type of freight car truck.

Eighth—To define length and spread of guard arm, and to consider the devising of a safety limit gauge for determining when M. C. B. couplers and knuckles are worn beyond a limit of safety.

Ninth—To revise the recommended practice of loading poles, logs, bark and other structural material on cars.

Tenth—To report specifications for M. C. B. couplers.

The election of officers resulted as follows:

President, C. A. Schroyer.

First Vice-President, John T. Chamberlain.

Second Vice-President, J. J. Hennessey.

Third Vice-President, W. J. Robertson.

Executive Committee: E. D. Bronner, J. H. McConnell, William Apps.

Treasurer, G. W. Demarest.

Mr. Blackall stated that Mr. Bronner had declined the nomination for the presidency.

Mr. Schroyer addressed the convention in a happy manner, after which it was adjourned at 1.30 p. m., Friday, June 17.

THIRTY-FIRST ANNUAL CONVENTION OF THE AMERICAN RAILWAY MASTER MECHANICS' ASSOCIATION.

The convention was opened with prayer by Bishop Newman, followed by the address of President Leeds. Satisfaction was expressed at the selection of Saratoga as a place of meeting of the association for the fourth time. The value of technical education was appreciated as a preparation for railroad service, and the student was specially needed now. The combination of technical and practical study was seen to be the only way to prepare young men for successful work. The advantages of holding the Master Car Builders' and the Master Mechanics' Association jointly occupied a prominent place in the address, and consolidation of the two associations was suggested. The comparative merits of different types of locomotives should be determined by a committee of the association, the plan suggested by the President being somewhat similar to that outlined in the discussion of this subject by Mr. M. N. Forney, on page 198 of our June, 1898, issue.

The report of the Secretary, which was then read, showed the present membership to be, active 598, honorary 26, and associate 18, a total of 642. There were no funds in the hands of the Secretary, and all bills had been paid. Two of the three association scholarships at Stevens Institute of Technology were now taken, and would be vacant again in two years. The members who had died during the year were:

J. F. Bryant, A. A. Daniels, F. J. Ferry, J. M. Hurst, D. G. Mott, P. H. Schrieber, J. P. Seward, Wm. Lannon, F. Mulligan and R. B. Harding.

The Treasurer's report was read and approved.

Messrs. Edward C. Bates and G. M. Basford were elected to associate membership, after which the association voted to accept an invitation from the Schenectady Locomotive Works and the General Electric Co. to visit the works of those firms at Schenectady, the Delaware & Hudson Canal Co. having offered transportation for members and guests.

The following names were ordered placed on the list of honorary members: Messrs. James Maglenn, Edward L. Coster, M. N. Forney and J. I. Kinsey.

REPORTS OF COMMITTEES.

Tonnage Rating.—Mr. W. H. Marshall opened the discussion by asking the committee to what extent the actual weighing of cars was recommended. He had found only five per cent. difference in figuring the weights and actually weighing cars, the weight of the loading being added to the stenciled light weight of the cars. Mr. Henderson had found more difference than this.

Mr. Manchester spoke of the effect of the condition of the tires of engines on the rating. The easiest and quickest method of obtaining engine rating would be selected for use, and uniformity in classes of engines for each division would assist in making up trains and would help the yardmaster. Many changes in profile and alignment had been discovered by the use of dynamometer cars.

Mr. Wm. Forsyth spoke of the changes in profile, which were not kept up to date on engineers' records. The question of variable speed introduced another factor in the result obtained, which affected the value of the velocity head. The subject was the most important of all having to do with handling freight. The report of the committee was to be commended, and co-operation of the mechanical and transportation departments in train loading would produce many good results in the improvement of track to promote economical operation.

Mr. Humphrey, being connected with a road among mountains, had found it necessary to rate engines on down as well as up grades. He had found serious discrepancies in the profile records on his road. He did not make any deductions for condition of engines, but allowed 10 per cent. reduction for winter ratings. He had found by experiment that five tons per car should be added for each empty car.

Mr. Henderson then closed the discussion. He showed that

the report had considered the question of profiles. Profiles were not always correct, but this should be looked after before using them in tonnage rating.

Best Methods of Boiler and Cylinder Insulation.—Mr. Wagner suggested that the committee should be continued on account of further work that might be done to add to its value.

Mr. Quayle explained that for some years he had protected locomotive steam pipes by their location in the saddles. The spaces were filled in with mineral wool, held by a plate. The proportions in the mixture of plastic coverings was important, and also its age in service. Some coverings improved by age. He used equal parts of asbestos, lime, slacked, and sawdust. Plastic coverings were preferred to sectional coverings, owing to the possibility of air currents taking heat away very rapidly when spaces were left open.

Mr. Browne reported favorable experience on the Pennsylvania with sectional coverings, except such portions as could not be covered by it. In these cases it was softened and applied in the form of plaster.

Mr. Marshall thought the results shown by the curves were not accurate on account of the loss by radiation from the water into the room. Also wood lagging was shown in the curves to be one of the best of the coverings, which reflected against the accuracy of the tests.

Topical Discussions.

The Special Apprentice.—Mr. Robert Quayle: Special, technically educated apprentices were growing more numerous. The regular apprentice, when of the right sort, need not be far behind the educated man. The best of each kind rapidly went to the front, and it was important to find what they were best adapted for. They were very satisfactory and especially on test work. They were paid more than regular apprentices, and after spending much time and money in study they were entitled to higher wages than the regulars, and were paid \$1 per day at first. The regular apprentices were offered equal advantages when ready to take similar work. There was no regular programme laid out for the specials, but they were given opportunities to thoroughly learn the shop methods. The members were urged to try the plan.

Mr. McKenzie believed it a good plan to start boys as laborers, rather than as privileged apprentices.

Mr. Marshall suggested the value of special apprentices in connection with special investigations and reports.

Locomotive Front Ends.—Mr. McConnell stated that the best arrangement of front ends depended upon the character of the fuel. Front ends clogged by cinders meant poor steaming. Lignite coal was difficult to use, owing to the difficulty in keeping the front ends clear and preventing spark-throwing, while at the same time obtaining free steaming qualities. The diamond stack, large nozzles and petticoat pipe could be combined to burn Wyoming coal with good results without throwing sparks. After five years' experience with extension fronts the ordinary front end and diamond stack was used to replace them, the results being very satisfactory.

Technical Education.—This discussion, opened by Prof. Hibbard, turned on the value of technical education to young men entering railroad work. The substance of the whole question was admirably put by Prof. Goss as follows:

There are several views to be taken of such a subject as this. A large view should prompt us to look upon the work of an educational institution as the work of drawing out and making larger men. There is a disposition always, when we think of technical work in schools, to connect them with the notion of the trade school. The trade school is an important factor in our educational system; but when we speak of our technical schools we do not think of a trade school, and the purpose of these schools is not to teach trades. It is for that reason we do not educate trainmen in our schools. That would belong to a trade school in railroad engineering. But we are developing men all the time. It was developed in the

discussion of the special apprentices that master mechanics don't regard the things that a man has learned in the schools. You don't credit him with being a machinist or a locomotive engineer, but you do find that that man can do things for you which the regular apprentice cannot do. He has power of thought and of absolute action which the regular apprentice does not possess. With his power, which has been obtained in the technical schools, it seems to me that we should keep in mind all the time that he has received the fundamental basis of knowledge upon which can be grafted the practical knowledge of the business with much greater success than in the case of one who has not received such a technical education.

Second Session.

Committee Reports.

Square Head Bolts and Nuts; Standard Pipe Fittings.—This was a report of progress, and it required further work, including the design of a complete set of standard unions, which necessitated conference with the manufacturers and the American Society of Mechanical Engineers. More time was asked for and granted.

Improved Tools for Railroad Shops.—Mr. T. R. Browne read this paper, which was printed too late to be distributed before the meeting. The paper called attention to the advantages of milling machines, turret lathes, cold saws, power hoists, and all of these combined with improved methods, shop methods being not less important than the tools.

The discussion was opened by Mr. Gaines, who favored the use of the milling machine. He had found an advantage of 50 per cent. in a comparative test between a milling machine and planer on keyway work, this being a confirmation of one of the conclusions of the committee.

High Steam Pressures.—The substance of the report was briefly presented by Prof. Goss. This was one of the best reports presented, and it drew out considerable discussion.

Mr. Henderson opened the discussion by showing that with longer runs and shorter time at terminals anything requiring delays for necessary work on boilers was objectionable. Quantity of work done by engines was more important than saving of fuel. If high steam pressure permitted the pulling of more cars it was good, but if it caused more repair work its advantage was questionable. Piston valves were strongly endorsed. Large boilers were more economical than small ones. They did not increase tractive power, but more power could be exerted at higher speeds. A locomotive boiler could not be made too large.

Mr. Tracy Lyon presented figures on repairs to boilers for pressures of 145 to 160 pounds, as compared with those on those carrying 160 to 175 pounds. It was particularly noticeable in connection with flues and staybolts, high pressures showing an increase in cost of repairs. Figures were quoted from one road showing an increase of 44 per cent. in flue and staybolt work on locomotives carrying 165 pounds pressure as against those carrying only 145 pounds in the same time.

Mr. Gaines did not believe it necessary to have more repairs with 200 pounds pressure if the designs were correct.

Mr. Marshall did not think sufficient experience had been had to show the effect of higher pressures on repairs. The high-pressure boilers had the advantage of improved tools and methods of working. The staybolt breakage and the repairs to new boilers specially designed to carry higher pressures were lower than before high pressures were used. The boilers were now better made. As regards long steam ports, the C. & N. W. practice was to reduce 20-inch ports to 16 inches, and good results had followed the change. Boiler capacity was very important. Very heavy engines with large heating surfaces were found more economical than small ones with restricted heating surfaces, and this was true even when the large engines were lightly loaded.

Mr. Forney emphasized the principle that within the limits of size and weights the boiler could not be too large. The

relations between heating surfaces, grate areas and fire-box volume were exceedingly important, and there were advantages in getting large volumes in fireboxes. Early experiments had shown that it was a good thing to restrict the grate area. The proportion of fuel burned was a subject concerning which more experimental work should be done. Judicious use of dead plates was probably to be made a means of very great improvement in economy. Combustion chambers had often been tried and frequently abandoned probably on account of faulty circulation. They were valuable in connection with the proper proportions of heating surface and grate area, and a satisfactory design was probably to be had. The boiler should not be neglected in favor of the engine.

Mr. David Brown testified to the continual troubles had with combustion chambers. He believed it important to prevent air from entering the firebox at the edges of the grates without going through the fire.

Mr. Wm. Forsyth emphasized the effect on the capacity of locomotives by increasing boiler pressures, which improved them as "hauling machines," and higher pressure as well as larger boilers would contribute to that result. Mr. Forsyth thought the best pressure was between 160 and 200 pounds, and thought it desirable to locate the best pressure definitely. He considered 180 pounds the upper limit for simple engines, this being based on experience with that pressure in freight service. He had found compounds to show 15 per cent. better economy than simple engines at that pressure. He did not know any upper limit to the compound.

Prof. Goss closed the discussion and stated that the subject was the efficiency of high-pressure steam and not the efficiency of locomotives carrying high-pressure steam. By vote the subject was referred to the committee on subjects with a view of further work in the same direction.

Cylinder Fastenings.—This report was accompanied by a supplementary report by Mr. J. E. Sague, being substantially a minority report, which resulted from impossibility to hold a meeting of the committee. The discussion was opened by Mr. R. Atkinson, who several years ago had found the necessity for better securing of cylinders to smoke boxes, and now used 21 bolts for this joint, and he had also found it necessary to reinforce the joints of mogul frame splices.

Mr. Henderson discussed the importance of providing for strains while engines are pushing trains and in being lifted in the shops. Keys between the cylinders were important to prevent cylinders from working upon each other.

Mr. Gaines called attention to the importance of providing for the expansion of the saddle castings, due to the effect of the heat from the inside and the cold outside. Expansion pockets were made in the castings to take these stresses from the bolts.

Topical Discussions.

The Use of Steel in Locomotive Construction.—Mr. Sague reviewed the progress of the use of cast steel. The effect of using it was to lighten the running gear and other parts to permit of putting more weight into the boiler. Some of the objections to its use were noted. Increased shop labor, delay in working in the shop, and delays due to defective castings, were mentioned. The first cost of construction was increased, but the result was a gain.

Mr. Henderson spoke of nickel steel for axles to secure lightness with reduced weight, and asked for information as to the heating of journals of nickel steel axles. The question was not answered.

The discussion then took the form of comparisons between forged steel and iron for axles. The Coffin process for axles, piston rods and crank pins was highly spoken of. European practice generally employed steel in place of iron in axles, and we would be driven to it, as Mr. MacIntosh said, "by the increasing use of steel, which rendered it difficult, if not impossible, to get scrap iron that would be entirely free from

steel." Early prejudice was difficult to overcome. The use of nickel steel was not extensive enough to warrant drawing conclusions.

Electric Traction.—Mr. P. Brangs supplemented his paper read at Old Point Comfort last year with a description of three phase current apparatus and comments on electric traction.

The session adjourned to take a special train for Schenectady, where the Schenectady Locomotive Works and the plant of the General Electric Company were visited. The attendance on the excursion was large, and the members found much to interest and instruct them at both establishments.

In the evening of June 21 Prof. Goss delivered a lecture illustrating by aid of stereopticon the Engineering Student at Work. It was an earnest, painstaking and able presentation of the work and the ideals of the engineer, his preparation for research work, his studies and practice, and the selection of his life work. He was shown in the class room, the laboratory and the workshop, the speaker's intention being to enable the members of the Association to understand the meaning of the education of mechanical engineers. The views were nearly all from Purdue University. The lecture was thoughtful, instructive, suggestive.

CLOSING SESSION.

The usual resolutions were disposed of, and, acting upon the report of the joint committee on Revision of Air Brake and Signal Instructions, instructions were ordered that when the pamphlet is printed it shall be stated that the revision has the approval of the Master Mechanics' Association.

Report of the Standing Committee on Apprentice Boy.—Mr. Bradley spoke of the suggestion that the subject should be taken up with other societies, with a view of uniform action, and Mr. Peck offered a resolution covering this, which was voted down.

Mr. Wagner emphasized the value of the work of night schools and from his experience believed that there would be no difficulty in raising funds for their maintenance in a community where mechanics and apprentices were employed. He had started such a school six years ago, from which gratifying results were obtained. Mr. David Brown indorsed what had been said with regard to the educational features and thought that the report should be criticised on account of having the boys with the men so much of the time. He would place the boys on their own responsibility, and change them from one machine to another until proficient, allowing them to finally remain in the shop which they should choose.

Mr. McIntosh believed that the committee had outlined an ideal plan, which should be followed whenever practicable. It should be adapted to the conditions of various shops, and used as an outline or guide. Mr. Tonge thought that the education should be adapted to the capacity of the boys, and believed that all apprentices should be treated alike, in order to avoid a lack of harmony among them.

Mr. Quayle did not agree with some of the previous speakers, particularly in regard to treating the apprentices all alike. He would not have a fixed rule for progress, but would advance each one according to his fitness for the work, upon the basis of "merit ought to win." Apprentices with technical education were usually older than regular apprentices, had maturer judgment and superior ability, which should enable them to push ahead of the others, and he did not believe in holding a boy back if he had ability. The report provided a plan which could be made sufficiently elastic to meet the conditions of any shop. Night school education was to be encouraged, and it was noted that probably many members of the association had been obliged to work hard at night in their own education.

Mr. Wm. Forsyth moved that the code should be adopted,

not as a standard, but as a plan recommended by the association. The code of apprenticeship was not suitable to all conditions, and should not be adopted exactly as it stood. The result was an indorsement of the code without making it the standard of the association.

Suggested Consolidation of the Two Associations.—Mr. Setchell read the report of a special committee, appointed to consider the recommendations contained in the President's address. The committee confined itself to the suggested consolidation, and favored bringing the two associations under one organization as being timely and practicable. A large proportion of the car mileage represented in the Master Car Builders' Association was controlled by Superintendents of Motive Power or Master Mechanics who are members of the Master Mechanics' Association, in which all Master Car Builders are eligible to membership, and there was no good reason why all business pertaining to the construction and repairs of engines and cars should not be transacted in one association and at one convention. Time and expense to the railroads would be saved, and fully as much work might be done in four days as now in six. The committee recommended that the executive committee of the Master Mechanics' Association should at once confer with the executive committee of the Master Car Builders' Association, and endeavor to arrange for a consolidation, which would do full justice to both associations, and it was provided that the President of the Master Mechanics' Association should appoint a special committee, who should also be members of the Master Car Builders' Association, to present the subject for consideration at the next Master Car Builders' Convention. Adopted.

Subjects for 1899.—The committee on subjects for the next convention, which was referred to the executive committee, was as follows:

1. A research laboratory under the control of the American Railway Master Mechanics' Association.
2. Water purification and the use of boiler purge.
3. Cast-iron vs. steel-tired wheels for passenger equipment.
4. The advantages of the ton-mile basis for motive power statistics.
5. What is the best method of applying stay bolts to locomotive boilers, including making the bolts and preparing the stay bolt holes?

6. Is it advisable to have flange tires on all the drivers of mogul ten-wheel and consolidation engines? If so, with what clearance should they be set?

7. Is it good practice to make locomotive fire-boxes with the crown and side sheets in one piece?

8. The use of nickel steel in locomotive construction; its advantages and proper proportion of nickel.

A motion made by Mr. Setchell was carried, authorizing the executive committee to change the date of the meeting for next year to suit the necessities of the association. Detroit, Lakewood, Old Point Comfort and Denver were suggested as places for holding the next meeting. The election of officers resulted as follows:

President, Mr. Robert Quayle.
 First Vice-President, Mr. J. H. McConnell.
 Second Vice-President, Mr. W. S. Morris.
 Third Vice-President, Mr. A. M. Waitt.
 Treasurer, Mr. J. N. Barr.

Each of the newly elected officers, except Mr. Barr, who was absent, addressed the convention in a few words, and in the remarks by Mr. Waitt it was made to appear significant that a Master Car Builder had been elected an officer in the Master Mechanics' Association. A number of the topical discussions were laid over until next year, owing to lack of time, and after a brief address by the retiring President, Mr. Leeds, the convention adjourned.

The proportion of locomotive and tender resistance to the total resistance of trains averaging 160 tons in weight and locomotives with tender weighing 85 tons more, as taken from data in a very elaborate series of tests on the Northern of France Railway, is about one-half the total, says "Engineering."

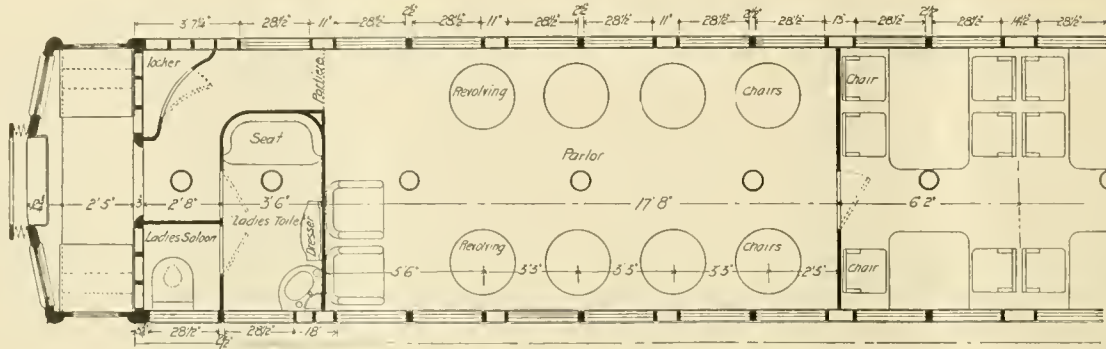

Parlor-Cafe Car, Illinois Central Railroad—Half Plan.



Illinois Central Parlor-Cafe Car.



Interior of Parlor.



Interior of Cafe Room.

COMBINATION CAFE, PARLOR AND BAGGAGE CARS, ILLINOIS CENTRAL RAILROAD.

The new train designated as the "Daylight Special" of the Illinois Central Railroad, now running between Chicago and St. Louis, includes an interesting car, which is a combination of dining, parlor and baggage accommodations in one car. Two of these have recently been furnished by the Pullman Palace Car Company, of Chicago.

The length of the car over sills is 72 feet 6 inches

and the width over the sills is 9 feet 8 inches. The total length is 77 feet 3 inches, and the weight is about that of an ordinary Pullman sleeper. The plan view shows that there is no front platform, that end being "blind," while the rear end is provided with a Pullman wide vestibule and a Session's steel platform, with National couplers. The lighting is by Pintsch gas, and the outside finish resembles the standard Illinois Central equipment, the inside finish being of mahogany.

The arrangement of the car brings the baggage compart-

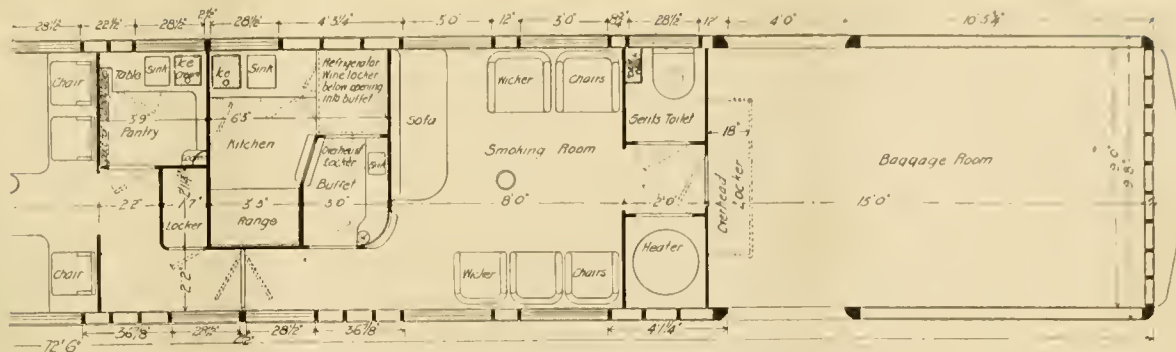

Parlor-Cafe Car.—Illinois Central Railroad.—Half Plan.

ment, a room fifteen by nine feet, at the front end. In the rear of this is a smoking-room, with five chairs and a sofa. To the rear of this and at the left of the passageway is the kitchen, which, though small, is complete in its appointments. The dining-room, or café, is in the rear of the kitchen. It is twelve feet long and has seats for twelve persons at four tables. Beyond this is the parlor compartment, with ten chairs, and the rear end is given to the ladies' toilet rooms. A good idea of the exterior and interior of the car is given by the half-tone engravings.

The framing is the Pullman standard, cantilever truss, with four truss rods. The roof is also standard, with square deck. The inside finish is of mahogany throughout, except the baggage compartment, which is finished in white wood. The ceiling is three-ply white wood, and the ceiling decoration is in color and gold. The heating is by steam, using the Safety Car Heating and Lighting Company's equipment, with New York Safety couplers. The trimmings of the car are of bronze; the brakes are by the Westinghouse Air Brake Company; the brake beams are the "Monarch"; the axles are of hammered scrap with 4 1/4 by 8-inch journals. Paige 33-inch wheels are used. The wheel base of the trucks, each of which has six wheels, is 10 feet 6 inches.

We are indebted to Mr. William Renshaw, superintendent of motive power, and Mr. F. W. Brazier, assistant superintendent of motive power of the road, for the information and to the Pullman Palace Car Company for the photographs and drawing of the floor plan.

HEIGHT OF DRAWBARS.

In discussing the question arising from the difficulty in keeping within the limits required by law as regards the height of drawbars, Mr. C. A. Schroyer, Superintendent of the Car Department, C. & N. W. Ry., made the following remarks before the M. C. B. Association:

"When cars equipped with both automatic and link and pin bars must be coupled together, the element of danger is increased in proportion to the variation in height of draught lines, due to the limited space in the opening of the knuckle face. These conditions are changed when there is no longer any necessity to go between the cars to use the links. I am of the opinion that the limit of three inches now allowed by law may safely be increased without in any way increasing the element of danger to life or limb in handling the cars. This being so, the questions involved, aside from the legal ones, are of a mechanical nature, and the handling of the cars safely in the movement of trains.

"I believe you are all familiar with the troubles, delays and expense now occasioned in maintaining the heights required. This is due to the amount of wear the wheels, journals and brasses are subject to. The additional lowering due to set of springs both permanent and under the load, the shrinkage of sills and draught timbers, the loosening of bolts and nuts, the bending of carrier irons, the manner of trimming load, etc., all affect the draught line to such an extent as to lower it below

the minimum limit of cars built to 34 1/2 inches, thus necessitating their being raised within a very short time. This in many cases must be done in a makeshift manner, unless construction is such as to enable change to be made without blocking. Natural wear of parts, shrinkage of timber, set of springs are so great that cars in service two or three years require raising.

"The face of the knuckle will average in width about 9 inches. When two cars are coupled together, one of which is the minimum height under the load, the other the maximum height empty, there still remains 6 inches of contact between the knuckles. The variation in the minimum and maximum height of draught lines may be safely increased from 3 to 4 1/2 inches, when we have yet remaining 4 1/2 inches of contact, when a car of minimum height is coupled to one of maximum. I think that this will be ample for all purposes in the safe handling of trains.

"Inasmuch as it is not necessary for brakemen to go between the cars in coupling, there is no element of danger in the switching yards. All of the railroads are doing their utmost to keep the draught lines within the limits required by law, and yet statistics show that many cars in service to-day vary much from the requirements, due largely to the conditions mentioned above, and multiplied by the manner of loading and the condition of tracks. I know of no trouble being occasioned by variations of 4 1/2 inches, and believe that automatic bars as constructed to-day will permit of a safe variation of the amount mentioned above when all cars in service are so equipped.

"I have said nothing regarding the heights of drawbars or the percentage of drawbars, the lines of which are above the the maximum or below the minimum. We have found much difficulty in getting cars of the proper height. We have furnished drawings to one manufacturing concern, and when the car was completed the draft line was just right, 34 1/2 inches. In the case of another company the draft line was nearly three-fourths of an inch above. The discrepancy was brought about by one-eighth of an inch here and one sixteenth of an inch there, and these small deficiencies are hard to overcome in the construction of a car. I wish it could be found possible to have the limits increased from three to four and one-half inches."

The proportion of large ships in the English navy is not nearly as great as is generally supposed. Sir William H. White, Chief of the Construction Department, in an article in the "Nineteenth Century," says: "Taking the 190 ships of the English navy, it may be interesting to arrange them according to displacement tonnages. There are 22 ships over 14,000 tons; all but two are battle ships; the exceptions are the "Powerful" and the "Terrible," cruisers. Between 12,000 and 14,000 tons there are 11 ships, seven battle ships and four cruisers; between 10,000 and 12,000, 10 ships, two being battle ships. Twelve cruisers are from 6,500 to 9,100 tons, 24 between 4,000 and 5,800 tons, 46 between 2,000 and 4,000 tons. Between 1,000 and 2,000 tons there are 22 vessels, and 43 are less than 1,000 tons. Little more than one-fifth of the total number are over 9,000 tons."

NORFOLK & WESTERN INSTRUCTION CAR.

By G. R. Henderson, Mechanical Engineer, N. & W. Ry.

This car was intended for giving instructions at different points on the road to the various classes of employees. It can be used not only for instruction in regard to air brake apparatus, but also for the different systems of heating and lighting in use by this road. The car was originally a single side door baggage car 40 feet 9½ inches over end sills by 9 feet 9 inches over side sills. The old arrangement of the doors and windows, consisting of a door at each end, a sliding door four feet wide at the center, and four windows on each side of the car has been retained. Entering at one end of the car immediately to the right is a toilet room, and joining this is a desk for the instructor, who will have the car in charge. Beyond the window which lights the desk is a complete outfit of the commingler storage heating apparatus in working or-

means of suitable cocks the manipulation of the engineer's valve on the locomotive will apply the brakes in the instruction car.

Near each of these various working parts is located a sectional model of the various fittings, so that the operation can be understood by an examination of the "intestines" of the model. Beyond this working apparatus is a sectional model of an 8 inch air pump, and the head of a 9½ inch air pump. There are also various diagrams attached to the side of the car illustrating the different parts employed. Connected with the working outfit is also a train signal valve and whistle, operated by five lines of pipe attached to the ceiling of the upper deck; all have independent whistle valves, and are all connected to operate the whistle in the locomotive equipment. Returning on the other side of the car, we have in the corner a small work bench and vise, and adjoining this five freight



Norfolk & Western Ry.—Instruction Car.

der, which has the commingler and all the working apparatus elevated from the floor so that it can be freely inspected on all sides and operated by the classes being instructed. Secured to the wall over this working outfit is a sectional model of the commingler, which has the various cocks and valves connected to a section of pipe line, showing the valve at the end of the car and the steam hose. Above this on the wall or side of the car is fastened one of the illustrated cards of instruction for working the commingler storage apparatus. This type of apparatus is used in heating the passenger cars of this company.

Beyond this is located a stove for heating when steam is not available, and adjacent to the stove is a model of the Leach sand apparatus, which is used on many locomotives. Beyond the side door at the center of the car, on the same side, is located the locomotive and tender equipment of the air brake apparatus, consisting of a reservoir, air pump, governor, engineer's valve, two driving brake cylinders, and tender brake cylinder, with proper auxiliary reservoirs, triple valves, etc. The piping is so arranged that the air pump can be worked by compressed air from an attached engine or the air of the engine can be forced directly into the main reservoir without passing through the air pump. This will be readily understood by the photograph, in which the lower pipe in the upper corner on the side of the car supplies the air from the engine. By

car brake cylinders and reservoirs secured to the side of the car in a vertical position, coupled up for working, and one cylinder and reservoir cut in section. Beyond this is a passenger car brake cylinder, with its detached auxiliary reservoir, the whole equipment being connected with six lines of train pipe supported from the upper deck and provided with proper cocks and couplings. In order to show the effect of additional length of train pipe, two additional reservoirs are placed under the car, connected with the train pipe by the vertical pipe which will be seen running down the side of the car.

Continuing on the same side, at the center door we have a sectional model of a locomotive lubricator and adjacent to that a direct steam heating coil, which illustrates the method employed in heating baggage and postal cars. This is also connected with the steam train pipe under the car, in the same manner as the commingler storage system is connected on the other side, and together with the latter illustrates the two methods of steam heating in use on this road. A sectional model of a Monitor injector, with diagram showing the different parts numbered is next in order, followed by the regulator, gauges, etc., of the Frost system of lighting by means of compressed air. A pipe leads to two carburetors on the roof, one of which supplies a Gordon-Mitchell, and the other a Siemens-Lungren lamp in the center of the car, as will be seen in the photograph.

It is the intention later to provide a vertical boiler for operating all this equipment, but for the present this has been omitted, and power must be supplied by the locomotive coupled to the car. This arrangement of having all the apparatus on the sides of the car gives a great deal more room for the instruction classes, and this can be readily appreciated by those who have used cars in which the center is filled by freight car brakes.

The spacious and roomy appearance of the car is well shown by the photographs, yet it must be borne in mind that this car is only 47 feet long.

THE STRENGTH OF TIMBER—A DISCOVERY.

A direct relation between the compression and transverse strength of timber has been discovered by Mr. S. T. Neely, an engineer engaged under Mr. B. E. Fernow in the investigation of strength of timber for the Government. Mr. Fernow de-

scribed the position of the neutral plane at any time until rupture, and has also shown how to calculate from a compression test the beam strength at rupture.

Other important results and deductions from these series of tests may be stated as follows:

1. Wood testing should be done preferably on green or soaked timber, thus eliminating the variable influence of moisture on strength, which begins to assert itself when the moisture is below 32 per cent.

2. A well-planned series on small laboratory sizes furnishes more reliable standard and average values for practical use than tests on large beams and columns. This conclusion is the result of some 60 tests on large beams, and over 100 tests on large columns, compared with over 1,000 tests on small pieces cut from them.

3. The best size for compression pieces to furnish the most uniform results is a cube of 2 or 3 inches.

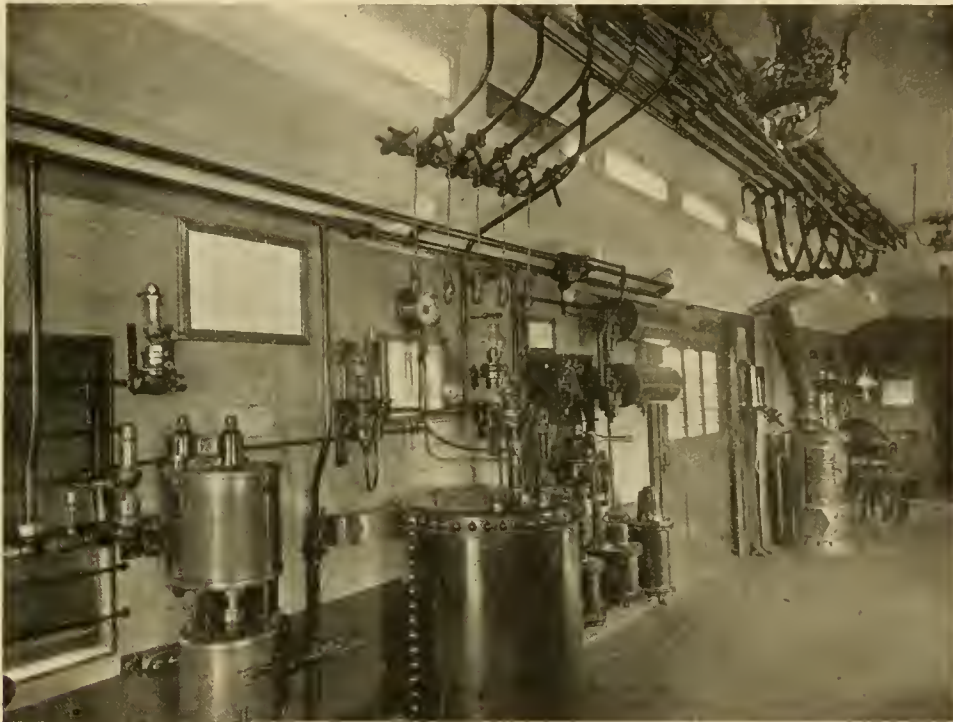

Norfolk & Western Ry.—Instruction Car.

scribed the results in a paper before the American Institute of Mining Engineers, from which the following paragraphs are taken:

1. It is established by theory and by extensive experiments that, in a beam loaded in the middle, the distortions are not only proportional to the load, but are equal on the compression side and the tension side of the neutral plane until the elastic limit has been reached.

2. From the study of strain-diagrams and data of several thousand tests it appears that the elastic limit of a beam has been reached when the extreme fiber-stress becomes equal to the compression strength of the material; in other words:

3. The cross-bending strength at the elastic limit is practically equal to the compression strength at failure, and we need only to determine the latter to have at once a safe basis for the designing of wooden beams.

This is the practical result: That the necessity for tests is reduced to a minimum, and no doubtful formula need be introduced in utilizing the test data. Since no beam should be designed to be strained beyond its elastic limit, nothing but the compression strength needs to be known for practical purposes.

Nevertheless, Mr. Neely has followed up the further behavior of the beam to rupture, has developed methods of determining

4. A difference of 10 per cent. in compression-strength values for conifers, and of 20 per cent. in hardwoods, cannot be considered as a valid difference for practical purposes, being chargeable to the natural variability of the material.

5. Wood compressed across the grain increases in strength comparatively, and does not lose its strength in endwise compression, pieces compressed to 50 per cent. of their original height exhibiting as much compression endwise strength as uninjured ones.

CAR SIDE BEARINGS.

Owing to the constantly increasing loads carried by freight cars, the question of whether the center plate should carry the whole load or should the side bearings be utilized to support portions of it, has become an important one, in which forms of frictionless side bearings are involved. In considering the objection to running cars with ordinary side bearings when these are in contact, Mr. A. E. Mitchell offered the following interesting figures before the Master Car Builders' Association at the recent convention, which we shall comment upon in a later issue:

"On the question of side bearings I have some data that may be of interest to the association. In November, 1897, we made a test with a dynamometer car on two trains, one of which

weighed 2,115 tons, and the other 2,114 tons, a difference of only one ton. The percentage of cars equipped with Fox trucks and metal body bolsters in one train was 100 per cent., all of which were center bearing. The other train was composed of diamond trucks and wooden body bolsters, only 12 per cent. of which were center bearing. There was no wind blowing, and both days on which the tests were made were as nearly alike as possible. The make-up of the trains was as follows: Number of cars in the first train, 22; in the second, 23; number of loaded cars in the first train, 21; in the second train, 22; number of empty cars in each train, 1. Length of first train, 834 feet; length of second train, 866 feet. Average drawbar pull, pounds per ton in first train, 12.84; in second train, 13.89, or 7.6 per cent. decrease in favor of first train. The average speed, miles per hour, first train, 11.97; second train, 11.13, an increase in favor of the first train of 7.5 per cent. The average boiler pressure, pounds per square inch, first train, 128.7; second train, 127.03, or an increase in favor of the first train of 1.1 pounds. The average reverse lever position, number of notch in the first train, 10.17; second train, 9.3, or an increase in favor of the first train of 9.3 per cent. The average coal burned per hour of actual running time, in pounds, first train, 2915.4; second train, 3177.5, a decrease in favor of the first train of 8.3 per cent. These figures show you the enormous saving which can be made if the cars are all center bearing."

PATENTS IN CHINA.

There is no patent office in China, and there is no treaty on the subject of patents between the United States and China. Minister Denby, writing from Peking, last February, said that, should disputes relating thereto arise between American citizens in China, they would be tried before the American consuls and decided according to the law of the United States. A patent held valid in the United States would be so held in China in all cases in which Americans are interested.

With regard to native Chinese, they stand in all these matters in the same relation to American citizens as the inhabitants of any foreign country. The international recognition of rights to patents, trade-marks, etc., depends entirely on treaties. In the absence of such treaties, there is nothing to prevent American books being reprinted, American trade-marks copied and native products sold under them and American patented goods reproduced by native workmen. The native laws, however, give remedies for fraudulent representation or obtaining money under false pretenses. I have on several occasions applied to the Chinese Government to furnish protection against the fraudulent use of American trade-marks. In each case energetic action has been taken by the local magistrates, and the perpetrators of the frauds have been punished and damages assessed.

Beyond such preventive action, I do not see how under existing treaties and laws the Government of China can do anything.

As between Americans and foreigners, these rights in China would depend on any treaties which the respective governments may have entered into regulating the protection to be afforded by their respective countries.

There is no objection to your selling to any railroad company the right to use your patent. Should the patent be afterward used by any other person without the right having been granted by you, you should appeal to your consul for redress. He would, if necessary, bring the matter to the attention of the legation.

TOOL RACK FOR FORGE SHOP—PHILADELPHIA & READING RAILWAY.

A convenient rack to hold all anvil and long-handled blacksmiths' tools, with a drawer for sand and borax and a cast iron vessel for water, is a good thing in forge shops. The one illustrated is in general use at the Reading shops of the Philadel-

phia & Reading, and was made from a sketch drawn by Mr. E. E. Davis, assistant superintendent of motive power of the road, some twenty-six years ago, while he was working in a blacksmith shop during a summer vacation. The sketch recently turned up in a search through some old papers, and was put into practical use at once, the result being so satisfactory as to warrant showing it to our readers.

The rack has three legs carrying at the top ends a flat plate perforated to receive the shanks of the anvil tools, while the handles of the hand tools are thrust between two circular rings of $\frac{5}{8}$ inch round iron surrounding the plate, and supported by lugs, which in turn support the plate from the legs of the stand. The top plate is 31 inches high, and about 18 inches from the floor a second perforated plate is supported, under which are two drawers, one for sand and the other for borax. The whole thing is cast iron except the two rings, and under the rack is a cast iron water bucket. The saving of time of



A Forge Shop Tool Rack.

the men in not being obliged to hunt for tools, and the saving of floor space in the shop, are important items, and in addition to these it is very easy for the foreman to note the condition of the tools at a glance, and the men do not need to stoop for the tools. The racks are neat and cheap, no machine work being required, and the idea merits a place in every blacksmith shop. Mr. Davis has them in use at about forty fires, and says: "I am sorry to say that 75 per cent. of our smith shops to-day are run about like the one run by 'the old man' when I was a boy."

CAST STEEL IN LOCOMOTIVE CONSTRUCTION.

In one of the noon hour discussions before the Master Mechanics' Association Mr. J. E. Sague presented the following comments upon cast steel in locomotive construction and the progress which has been made in its application:

"Cast steel has become a most important material of locomotive construction, and the past year has witnessed marked improvement in its manufacture and in the design of parts made of it. Probably the main advantage obtained by the use of cast steel in locomotive work is that it has permitted considerable reduction of weight in various details, and has then allowed more weight to be put into the boiler. This, especially in passenger locomotives, has increased the efficiency of the machine by allowing the use of an amount of grate and heating surface which would be practically impossible within permitted limits of wheel weights if a stronger material had

not been available to replace cast iron in such details as driving wheel centers and foot plates. In cast steel we have a material which can be obtained with a minimum tensile strength to 90,000 pounds or more with a corresponding reduction in ductility. The best quality of cast steel for various locomotive details has not yet been fully determined, but in practice steel of nearly the lower limit of tensile strength appears to be preferred. It would be interesting to hear the opinion of steel makers on this point. Aside from the aim of saving weight, cast steel is used for many details in which cast iron had proved deficient in strength, such as the main wheel center of six and eight-wheel coupled freight engines, driving boxes and crossheads. Cast steel is also being widely used to replace expensive forgings, and it then permits greater latitude in design than is possible with forgings, and therefore secures a better job.

"It is interesting to note, however, that flanged and forged steel can be used in some cases to better advantage than cast steel, especially in boiler construction for dome rings, caps, etc. The advantage of cast steel is so well known that it may be profitable to mention some of the objections to its use. Cast steel has a greater shrinkage than iron, and is therefore more liable to strain in casting and consequent defects. Its rough finish, compared with cast iron, involves more expense in preparing the surfaces for the painter, and more imperfections for the latter to fill and cover up. The bardness and toughness of cast steel increase machine shop labor, and mean more tools for a given output. An important element to consider is the delay in locomotive manufacture and repairs caused by the extra time required to make steel castings as compared with iron, and the vexatious delays caused by castings which develop defects in machining. It is but fair to say that most of the above objections, though still serious, are being rapidly lessened by the great improvements in steel making and by the increase in capacity of the steel foundries.

A LOCOMOTIVE BOILER FLUE SWAGE.

The accompanying engraving illustrates the construction of a swage for preparing locomotive boiler flues for safe ending. It was devised by Mr. R. M. Galbraith, General Master Mechanic of the St. Louis Southwestern Railway, and is used in the shops at Pine Bluff, Ark. The flues to be safe ended

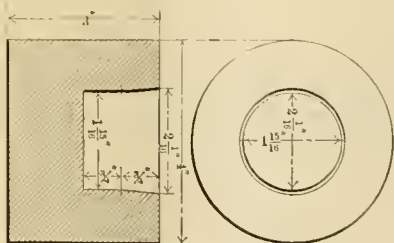

are heated at one end and entered into this block. The flue is then driven home, to the bottom of the block, by striking it upon an anvil. The swage block gives a perfectly round end to the flue and reduces its diameter to the proper amount when it is removed for use upon another flue. The engraving shows the dimensions and the form of the swage.

LIFE OF WOODEN BRIDGES.

In a discussion of the subject of wooden bridges at a recent meeting of the employees of the bridge and building department of the Chicago, Milwaukee and St. Paul Railway, Mr. E. S. Meloy said:

I have begun the compilation of the life of over 100 miles of wooden bridges of the class above mentioned, from which the following is extracted: The life of floors on pile bridges ranges between 7 and 11 years, the average being 9 years and

1 month. The percentage of renewals for the different ages are as follows: Renewed under 7 years, 3.1 per cent.; renewed in 7 years, 7.7 per cent.; renewed in 8 years, 14.9 per cent.; renewed in 9 years, 28.7 per cent.; renewed in 10 years, 31.6 per cent.; renewed in 11 years, 10.7 per cent.; renewed after 11 years, 3.3 per cent. Our Howe truss spans are subjected to much the same conditions that regulate the life of the pile bridges, and the average life of 281 spans, renewed during the past 9 years, is found to be 9 years and 6 months, being only 5 months greater average life than pile bridge floors.

Floors on iron bridges are subjected to fewer of the elements that tend to terminate the life of bridges than any other class, and the records of floors on 57 spans give an average life of 10 years and 2 months.

Concerning the life of wooden culverts, we have the records of over 6,000, which give an average of about 11 years. The greater portion of these culverts were built of new timber, but the policy now is to use only good second hand timber, and as our culverts built on this plan have all been constructed within 9 years, we cannot make a comparison between new and old timber.

In burning coke under steam boilers in order to overcome the smoke nuisance, many trials have been unsuccessful as regards economical working, and Mr. H. W. Spangler, writing in "Cassier's Magazine," tells some of the reasons. Coke being nearly pure carbon, requires a great deal more air per pound of fuel than coal does, and it also requires a deep bed of fuel, no fire being more difficult to restore to good condition after running low than a coke fire. There is little flame to coke, and the most valuable heating surface is directly over the fire. The heating surface in tubes may be smaller and the grate should be larger for coke than for coal. About two-thirds as much coke as coal may be burned per square foot of grate per hour in ordinary running, and from 30 to 40 per cent. of the grates should be open for the admission of air. It is also necessary to keep the plates over the fire cleaner than is required for coal burning.

"Aerial Rope Railways" was the subject of a paper read recently before the Liverpool Engineering Society by Mr. J. Walwyn White. It had special reference to the traffic between Liverpool and Manchester, and was reported by "The Engineer" as follows: "The system of carrying the loads in the air by means of aerial ropeways seemed to meet certain of the conditions. It did not interfere with ordinary street traffic, while it avoided all questions of compensation for severances, purchase of costly land, or building costly bridges. Only a small foundation was needed about every 300 ft., where supporting standards were placed, and he would use a separate rope for each span of roadway, thus evading some difficulties, and no rope was called to bear a greater strain than was due to the maximum load ever upon one span at a time. There were special advantages in the case of electric haulage. An automatic and effective absolute block system was provided, the passing load making its own electrical connections, and no load getting within a clear span of the load in front or behind it. The goods were to be loaded on a loose top on the horse lorry, and this with its load would be lifted and hooked on to the ropeway carrier. The ropeway could transport 6,000 tons per day at a working speed of five miles an hour. Branches could be taken off to supply intermediate towns. He would place a high signal tower every five miles and in telephonic communication with each other. He estimated the cost of thirty-five miles of double lines between the two cities, with complete outfit, at \$1,800,000, and calculated a net profit of \$300,000 a year, or sufficient to pay a dividend of 13 1/2 per cent. on the cost, without reckoning some of the probable sources of profit he mentioned."

Electrical power transmission has been decided upon by the Russian Admiralty, for use in all warships, for raising ammunition, loading and working the guns and similar purposes.

COMMUNICATIONS.

FIRST STANDARD GAGE LOCOMOTIVE IN CHINA.

Editor "American Engineer:"

The difficulties met with in the first introduction of the steam locomotives are not without their counterpart in China, and I believe your readers will be interested to know about the first Chinese locomotive.

The Chinese Engineering and Mining Co. had opened their coal mines at Kai-ping, eighty miles from Tientsin, with which it is now connected by rail. In those days there was no railway and the mines were eighteen miles from navigable waters. Moreover, a canal could only be carried to within seven miles of



The "Rocket of China."

the mines. After much delay and governmental expense permission was granted by H. I. H., the Son of Heaven, for the construction of a tramway from the mines to the head of the canal at Su-Ko-chung. This tramway was to be operated by mules, ponies and Chinamen. No permission for the use of a locomotive could be obtained, consequently as none could be ordered from abroad the chief engineer decided to build one without permission and then prove to the Chinese its superiority over mules, etc. The object was not to build a first-class locomotive, but to build, at as slight a cost as possible, a locomotive that would serve as an object lesson. The photograph shows the result.

The boiler was taken from an old English portable engine.

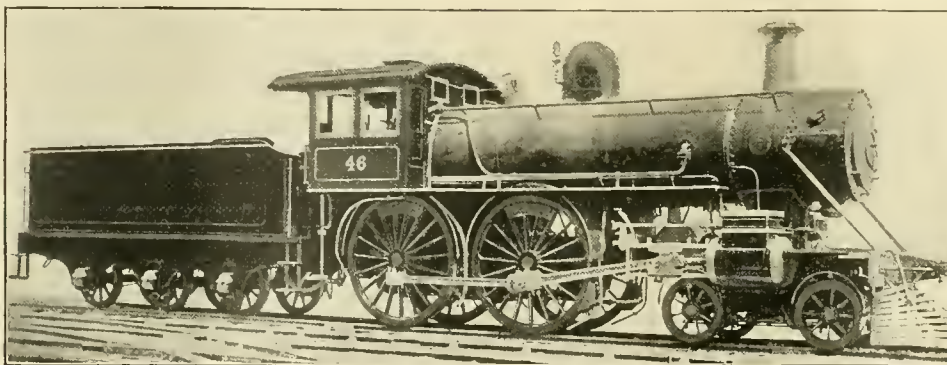

Modern Baldwin Locomotive for Peking-Tientsin Line, China.

The cylinders, 8 by 15½ inches, were from a winding engine. The driving wheels were of American chilled iron, 30 inches in diameter, and purchased as scrap. The frame and channel irons were taken from an old headgear of No. 1 shaft. The wheel base was 8 ft. 4 in.; the weight on drivers 6 tons. The engine had side tanks and end coal bunkers, one motion pump, one donkey pump and Stephenson's link motion. The cost completed for labor and other than old material was \$540.

The locomotive was run for the first time on the centenary of the birth of George Stephenson, and very naturally was christened the "Rocket of China." On November 8, 1881, the first trip over the main line was made, a run of seven miles and return, with two coal cars full of delighted officials. After that

she made 12,000 miles and is now a fixture in the railway shops, her only duty being to run a pump.

There is now in operation over 300 miles of railway, with some sixty modern locomotives, with thousands of miles of projected lines that will soon be under construction. All of the locomotives for the Peking-Tientsin line are American, by the Baldwin Locomotive Works. The photograph shows one of these fast passenger engines, with driving wheels seven feet in diameter. The photographs are of the same scale, and the two illustrate very correctly the progress made by China during the last few years.

ANDREI KMITA.

Peking, February 5, 1898.

DRAFTSMEN FROM TECHNICAL SCHOOLS.

American Engineer:

Referring to your editorial inquiry in April issue for the reasons for the lack of good detail draftsmen, I submit that there are two principal reasons.

First, Insufficiency of technical school training. There is little justifiable excuse for this, as the schools are chiefly in industrial centers where it is easy to duplicate the conditions of actual drafting room service. Equipment is ample, even luxurious, but an essential thing very frequently lacking is a true ideal of service. The ideal draftsman is, like the mathematician, a man of fine scholarly attainments, satisfied with achievements in a field which cannot be popularly understood, nor have any part in common notoriety. It is the most quiet, elegant and brainy part of engineering. But our schools are on a basis of appeal to popularity. The ideals which they make most prominent are those of a prosperous contractor and the hustling man of affairs, a sort of advertising apotheosis of engineering which makes for padding and sciolism. These ideals, which are very persistently taught, are not productive of the mental qualities of a good draftsman.

Second, The absorption of much of the best drafting talent in selling and executive business. A draftsman may prepare designs which are the making of a successful factory, but after the patterns are completed his work as a designer in that connection is done. The clerk, a man of lower capabilities, is continually needed in the business, but the draftsman must either seek a new connection and slowly win the confidence of a new set of associates, only to repeat the experience again

and again, or he must become a manager of manufactures or sales. As such he may have an excellent career, but the draftsman is lost.

The ideal draftsman, then, who excels in his work and loves it for its own sake, must adhere to it with great singleness of purpose. He must oppose the ideals of the schools, and the temptations of business promising more in wealth and permanence. So when advertisers look for him he is found to be no longer in waiting, and they must content themselves with training to their requirements some young man who expects to use the drafting table as a stepping stone to the office desk.

CHARLES H. FITCH.

Chicago, Ill., May 29, 1898.

VALVE MOTION FOR STEAM MOTOR CAR—DETROIT & LIMA NORTHERN RAILWAY.

The interesting arrangement of the valve gear of the steam motor car built by the Baldwin Locomotive Works for the Detroit & Lima Northern Railway, was mentioned in the description of that car in our April (1898) issue, page 135, and the construction of the gear is shown more fully by the accompanying engraving. The arrangement is patented. Its chief object was to bring the links up into the body of the car, rendering them accessible and protecting them from the dust. The shortness of the wheel base and the proximity of the axle to the ground made it specially desirable to protect the links, and it was considered important to use a modification of the ordinary Stevenson link motion.

The eccentrics are on the forward driving axle and work ver-

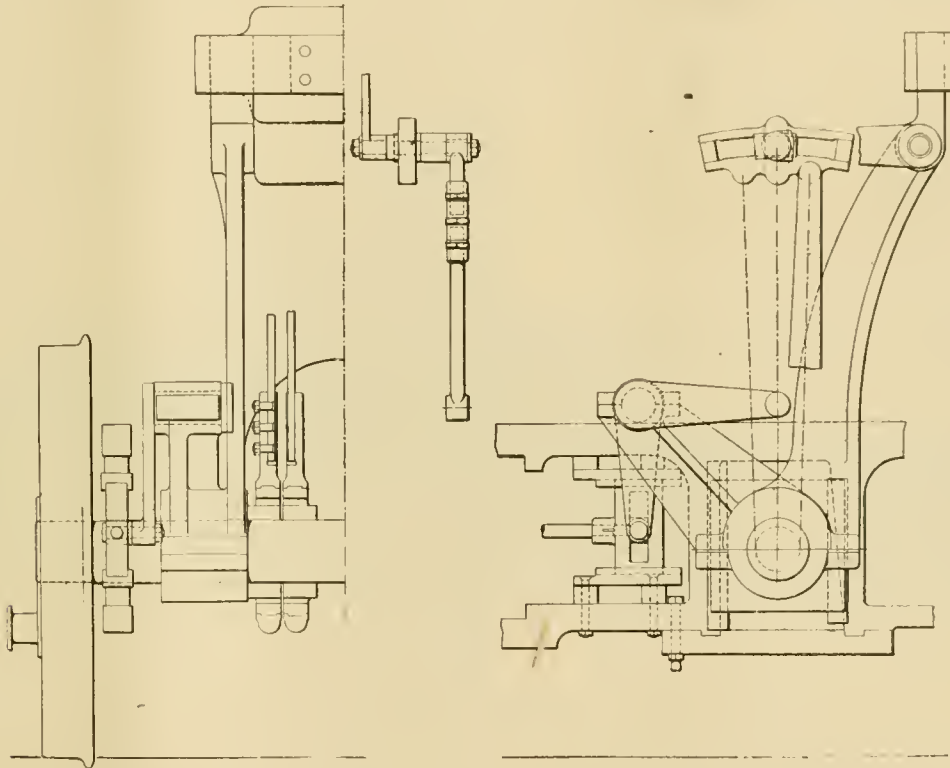

Valve Motion—Baldwin Steam Motor Car.

tically like those of a marine engine, the links being horizontal. The axle carries a bearing from which an arm projects upward to a clamp on the boiler, through which its upper end passes with freedom for vertical motion, and a bar pivoted on this arm fixes the position of the link block. The motion of the link block is imparted by a rod and rock shaft to a slotted cross-head running on guides placed between the bars of the frame and from this the valve rod passes to the valve stem. The rock shaft is journaled in a second arm projecting from the bearing on the axle. The slotted cross-head allows vertical motion to take place between the axle and the frame without affecting the length of the valve connection. The links and the rock shaft bearings move vertically with the axles and the valve rods move with the frames to which the cylinders are attached.

The device is a simple one and it appears to fulfill its objects admirably.

WIDE RANGE OF COMPRESSED AIR.

There can be no more convincing commentary upon the wide range of applications of compressed air power than the sales report of the Clayton Air Compressor Works, Havemeyer Building, New York, for the months of February, March and

April. In all, nineteen air compressors were sold for operating pneumatic stone tools, chipping and calking tools, air hoists, etc.; nine air compressors for moving and elevating acid and chemical solutions; four air lift pumping plants were installed and placed in operation; three air compressors were furnished to rubber works for removing hose from mandrels, testing hose and inflating tires; one compressor was supplied for the pneumatic transmission of messages; two for oil burning plants; three for racking off beer in breweries; one for spraying brick in the process of manufacture; and six for unusual applications of compressed air power. In addition to this number of air compressors furnished for domestic use, four were exported to Europe for operating pneumatic shop plants. Among the orders of especial interest included in the above summary may be mentioned the plant installed at the navy yard, Brooklyn, New York, for supplying pneumatic drills, paint machines and hammers, and one furnished to the Yarrow Ship Yard, London, for operating pneumatic tools. Another installation of interest is the compressor at the Dunn Building, New York, which supplies compressed air dusting nozzles for cleaning the iron grill work of the elevator shafts. Among the orders now in hand is

a large compressor for the Bath Iron Works, Bath, Me., to operate pneumatic tools.

The rapid acceleration of trains is one of the advantages sought in the application of electric traction to suburban lines of railroads. Rapidity in starting and fair maximum speed will increase the average speed for service that requires frequent stops, far beyond that possible with high maximum speed and low acceleration. It is reported that the schedule proposed for the Chicago suburban lines of the Illinois Central contemplates an acceleration of 40 miles per hour in 20 seconds after starting and it is understood that the electrical companies are figuring on this basis. Such a rate of acceleration would be almost ideal from the standpoint of the passenger, but there are other considerations, such as the size of the motors and the load line at the power house, that prompt the question whether it is not possible to go too far, or too fast, even in such an important improvement as this. The motors for rapid acceleration must be large and the load on the generators heavy at starting and almost nil afterwards, and this comprises a very expensive distribution of power, that would only be economical with an enormous number of train units, a condition that does not exist on such railroads. Good engineering and good business management would seem to recommend more moderate acceleration and better conditions for economical operation. The experience of the Metropolitan Elevated in Chicago points to the advisability of using moderate acceleration.

PERSONALS.

Mr. Warren G. Purdy has been elected President of the Chicago, Rock Island & Pacific.

Mr. J. R. Slack has been appointed Mechanical Engineer of the Central Railroad of New Jersey.

Mr. J. C. Whitridge, Associate Editor of the Railroad Gazette, has received the degree of Mechanical Engineer from Purdue University.

Mr. Herbert Roberts has been appointed Superintendent of Motive Power of the Norfolk & Southern, succeeding Mr. G. R. Joughins.

Albert P. Massey, Mechanical Engineer of the New York Air Brake Company, died at sea on June 5, on the way to Europe, at the age of 56 years.

Mr. J. J. Thomas, Jr., has been appointed Master Mechanic of the Montgomery Division of the Mobile & Ohio Railroad, with office at Tuscaloosa, Ala.

Gen. Robert J. Stockton, President of the United New Jersey Railroad & Canal companies, died at his residence in Trenton, N. J., May 5, at the age of 66 years.

Mr. G. W. Seidl has been appointed Master Mechanic of the Baltimore & Lehigh, with headquarters at Baltimore. The office of General Foreman of Locomotive Repairs has been abolished.

Mr. James M. Naughton has resigned as Superintendent of Motive Power of the Wisconsin Central to accept the position of Superintendent of the Brooks Locomotive Works at Dunkirk, N. Y.

Mr. J. W. Marden has been appointed Superintendent of Motive Power of the Fitchburg, to succeed Mr. John Medway. Mr. Marden has been Master Car Builder of the road for a number of years.

Mr. J. W. Gardner, recently connected with the Sterling Boiler Co., and for a long time Western Manager for Manning, Maxwell & Moore, has accepted a position in the sales department of the Sargent Co.

Mr. George Westinghouse has been elected an honorary member by the German Society of Locomotive Engineers, which has about 14,000 members, "as a recognition of his services to transportation by the invention of his railroad brake."

Mr. E. S. Marshall, formerly manager of the Railway Department of the Missouri Malleable Iron Co., has resigned to become general sales agent of the Missouri Car & Foundry Co., with office at St. Louis.

Professor H. Wade Hibbard, who has for several years been at the head of the railway mechanical engineering department of the University of Minnesota, has recently been appointed principal of the new Graduate School of Railway Mechanical Engineering of Cornell University, Ithaca, N. Y.

Timothy Case, formerly General Superintendent of the Green Bay, Winona & St. Paul, died suddenly in Chicago, May 9. He was born in Middlebury, Vt., in 1823, and began his railway career in 1849 as foreman for the contractors constructing the Hamburg tunnel on the Hudson River Railroad. Since March, 1885, he has lived in Chicago.

Mr. Boone V. H. Johnson has been appointed Assistant Engineer of the Safety Car Heating and Lighting Company, at St. Louis, in place of Mr. W. H. Hooper, promoted to the position of General Agent of the same company at Chicago. Mr. Johnson was formerly with the Pullman Company, and recently with the New York, New Haven & Hartford Railroad Company, at New Haven, Conn.

Mr. R. F. Hoffman, who has for the past year held the position of Mechanical Editor of the "Railway and Engineering Review," has recently resigned to engage in special mechanical engineering work in the motive power department of the Atchison, Topeka & Santa Fe Ry. His many friends will join us in wishing him success in his new position. Mr. Hoffman's attention will be concentrated on the use of locomotive fuel.

Mr. Edward L. Coster has been appointed Assistant in Mechanical Engineering at Columbia University, New York City. He has for a number of years been a careful student of mechanical railway subjects, and is an honorary member of the American Railway Master Mechanics' Association, and an associate member of the American Society of Mechanical Engineers. He will have direct charge of the new Columbia locomotive testing plant during its construction and afterward.

Mr. E. G. Allen, for the past five years General Superintendent of the Old Colony system of the New York, New Haven & Hartford, has resigned. Mr. Allen has been in railroad service for 33 years. In 1891 he was made Superintendent of the Central Division of the Old Colony Railroad and when that road was absorbed by the New York, New Haven & Hartford in 1893 he was appointed General Superintendent of the Old Colony Division.

Mr. G. R. Joughins, heretofore Superintendent of Motive Power of the Norfolk & Southern, has been appointed to succeed Mr. Francis R. F. Brown as Mechanical Superintendent of the Intercolonial of Canada, recently resigned. Mr. Brown was born and educated in England, and began railroad work there in 1863, on the Great Northern Railway. He has had an exceptionally wide and successful experience in England, India and Canada, and is an accomplished civil and mechanical engineer as well as locomotive superintendent. His successor, Mr. Joughins, is well known in this country, especially with regard to his designs in metal car and truck construction.

Dr. Charles E. Emery, one of the foremost and best known American Mechanical Engineers, died in Brooklyn, N. Y., June 1. He was born in Aurora, N. Y., in 1838, and was educated in that State, showing a tendency toward engineering pursuits when very young. He had some experience in a railroad drafting room, and in a country foundry and machine shop, and also studied law. In 1861 he entered the navy as Assistant Engineer on the steamer "Richmond," and remained in the service in sea or experimental work until 1869. He was afterward consulting engineer to the U. S. Coast Survey, and did a great deal of original test work on steam engineering subjects. His greatest work was the design and construction of the plant of the New York Steam Co., of which he was Chief Engineer and later General Manager. For the past 10 years he has been engaged in general consulting work, and his services have been in great demand. He was prominent in the engineering societies and was awarded the Watt medal and Telford premium by the Institution of Civil Engineers (England). He was a highly accomplished engineer, a keen observer, a thorough student and ready speaker, especially on engineering subjects. His delightfully courteous way of speaking of and to those who disagreed with his views was a characteristic that struck many who did not have the benefit of a personal acquaintance.

TWO NEW MACHINES—THE NILES TOOL WORKS.

AIR MOTORS—METROPOLITAN STREET RAILWAY, NEW YORK.

The two machines shown in these engravings are new productions of the Niles Tool Works Co., Hamilton, Ohio.

The first is a duplex horizontal milling machine, built for heavy work, and is powerfully driven and geared, the cone driving pulleys having wide faces for large belts. The bed of the machine has two wings, upon which the uprights are seated. The uprights may be adjusted laterally without disturbing their alignment, thus providing for a wide range of work. As the wings are cast in one piece with the bed, the adjustment of the uprights does not affect their rigidity. The spindles are large and hollow and run in bronze bushings, provision being made for taking up end thrust and wear. The spindle heads present large square surfaces to the uprights, and are, as is also the table, square gibbed. Both uprights and bed are extremely heavy, well proportioned and heavily ribbed, and the metal

The Metropolitan Street Railway Company has made a contract with the American Air Power Company for the equipment of the Twenty-eighth and Twenty-ninth street line, New York city, with the Hoadley-Knight air motor. The contract is for the complete equipment, including twenty cars, which will be of the same type and external appearance as the Broadway cars. A new power house will be built on the property of the Metropolitan Company in West Twenty-third street, opposite the Pennsylvania terminal. The air compressor for which order has been placed is of 1,000 horse-power capacity, and is of the Ingersoll-Sergeant Four-Stage Single-Acting type, provided with intercoolers between each pair of cylinders, and a final cooler after the fourth stage cylinder. The air cylinders are vertical, and will be set underneath the engine, which is a vertical cross-compound condensing Reynolds' Corliss engine, built by the E. P. Allis Company. Air will be compressed to a

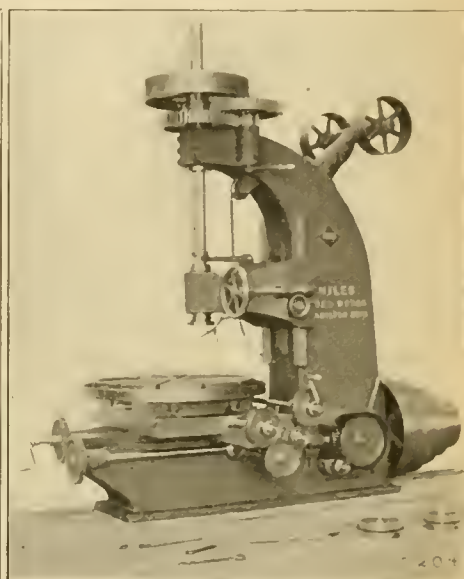
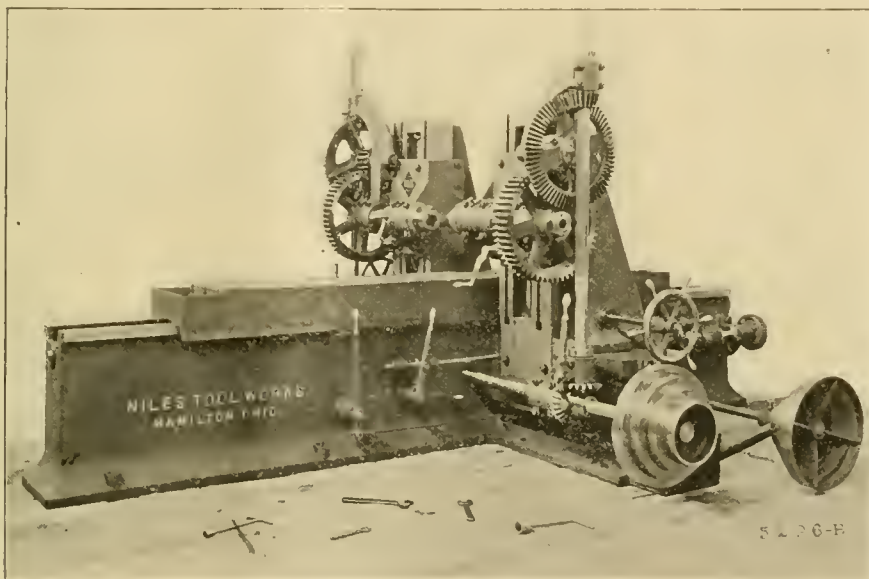

Fig. 1.—Duplex Horizontal Milling Machine.

Fig. 2.—Vertical Milling Machine.

THE NILES TOOL WORKS. HAMILTON, OHIO.

is distributed to withstand the strains due to heavy cuts. The shafts and gears are of ample proportions, and all gears are cut from the solid. The table has power feed and power quick return. All handles for controlling the movements and feeds of the machine are placed within convenient reach of the operator, thus enabling him to watch his work, while using the handles for throwing in or reversing the feeds or for stopping or starting the spindles. The lubricant used in cutting is collected in suitable troughs and led to a reservoir in the bed.

The second, known as the "No. 6 Vertical Milling Machine," is specially intended for use in railroad shops for milling links and general profiling work, the appearance of the machine being clearly shown in the engraving. The spindle is driven direct by belt for fast speeds and by back gears for heavy work. The maximum distance from the table to the end of the spindle is 26 in., the distance from center of spindle to column 24 in., the diameter of the circular table 42 in., longitudinal traverse of table 20 in., and the transverse traverse of table 32 in. The driving cone pulley has four steps for a 4½-in. double belt and cross; longitudinal and circular feeds are provided, arranged so as to be operated from the front or side of the machine. The facilities for profiling work are excellent, owing to the longitudinal, cross and circular feeds of the circular table, which may be operated by power or by hand.

suitable pressure and will charge the cylinders or bottles used in the cars.

The American Air Power Company, which was formed by the combination of the Hoadley-Knight and Hardie Companies, has a capital of \$7,000,000. Its relations with the Metropolitan Company have been very intimate, and for several months past part of the power-house at 146th street and Lenox avenue has been used by the Air Power Company for experimental work. Several cars have been equipped with air motors there, and have been successfully run over the Lenox avenue line.

A handsome furniture car made by the Northern Pacific Railway Company at its shops in South Tacoma, Wash., will soon go forward and be placed on exhibition in Omaha. It is a fine advertisement of western coast lumber. It is forty-two feet in length, with a capacity of 70,000 pounds. It is finished in oil, and is built of fir, cedar, and spruce, with a little oak used in the door-frames.

Thirty new consolidation freight locomotives have been ordered during the past week by the Baltimore & Ohio Railroad, and the order has been divided as follows: The Baldwin Locomotive Works, fifteen with 21 by 26 inch cylinders, and five with 22 by 28 inch cylinders; the Pittsburg Locomotive Works, ten with 22 by 28 inch cylinders; the large engines are for use on the mountain divisions while the others are of the same class that are being used between Cumberland and Baltimore.

(Established 1832.)

AMERICAN ENGINEER

CAR BUILDER AND RAILROAD JOURNAL.

29TH YEAR.

67TH YEAR.

PUBLISHED MONTHLY

BY

R. M. VAN ARSDALE,
MORSE BUILDING.....NEW YORK

G. M. BASFORD, Editor.

JULY, 1898.

Subscription.—\$2.00 a year for the United States and Canada; \$2.50 a year to Foreign Countries embraced in the Universal Postal Union. Subscriptions for this paper will be received and copies kept for sale by the Post Office News Co., 217 Dearborn Street, Chicago, Ill.

EDITORIAL ANNOUNCEMENTS.

Advertisements.—Nothing will be inserted in this journal for pay, EXCEPT IN THE ADVERTISING PAGES. The reading pages will contain only such matter as we consider of interest to our readers.

Special Notice.—As the AMERICAN ENGINEER, CAR BUILDER AND RAILROAD JOURNAL is printed and ready for mailing on the last day of the month, correspondence, advertisements, etc., intended for insertion must be received not later than the 20th day of each month.

Contributions.—Articles relating to railway rolling stock construction and management and kindred topics, by those who are practically acquainted with these subjects, are specially desired. Also early notices of official changes, and additions of new equipment for the road or the shop, by purchase or construction.

To Subscribers.—The AMERICAN ENGINEER, CAR BUILDER AND RAILROAD JOURNAL is mailed regularly to every subscriber each month. Any subscriber who fails to receive his paper ought at once to notify the postmaster at the office of delivery, and in case the paper is not then obtained this office should be notified, so that the missing paper may be supplied. When a subscriber changes his address he ought to notify this office at once, so that the paper may be sent to the proper destination.

The paper may be obtained and subscriptions for it sent to the following agencies: Chicago, Post Office News Co., 217 Dearborn Street. London, Eng., Sampson Low, Marston & Co., Limited St. Dunstan's House, Fetter Lane, E. C.

One of the committee reports before the recent convention of the Master Mechanics' Association is a model in construction and execution. It is unique and presents an idea worth copying in committee work in general. The report itself was prepared by the whole committee, and signed by all of the members. Then each member made a study of some special branch of the subject and considered it in some one of its bearings upon other things, and these are given in the form of appendices, not less valuable than the report itself. We refer to the report on higher steam pressures.

Three subjects of the many taken up at the recent convention of the Master Car Builders' Association stand out prominently as those from which important results may be expected. They are the recommendation of specifications for automatic couplers, and the allowable limits of wear in service, the subjection of all types of triple valves for air brake apparatus to tests by the committee having this matter in charge, and the disposition of the request for an adjustment of the prices paid for labor and material in the repair of freight cars west of the 105th meridian. Satisfactory reports upon these matters will constitute a successful year in the history of the association.

When we say that steel cars, one of the most important subjects before the Master Car Builders' Association, was not properly treated at the recent convention, we voice the opinions of a great many influential mechanical railroad officers, and it is to be regretted that another year has passed with so little light thrown upon the steel car problem. There was practically no discussion of the report at the proper time, yet there was a great deal of it outside of the convention, and particularly during the Master Mechanics' convention. Is the Master Car Builders' Association shirking a difficult but most important task?

Last year four designs for steel cars were submitted to the association by individual members, and at Saratoga it was expected that much interest would be shown in them and in the widely different principles of construction which they embodied. Since that time several other designs have appeared, and practical tests in service have been made with large capacity steel cars, and not a word said about them in the discussion except to direct attention to the need for heavier draft gear. During the year steel cars have been wrecked; surely the experience gained was valuable, and there is apparently no subject more worthy of the attention of a standing committee than this, even if the work done is merely historical. Many will doubtless join us in believing that a mistake was made in not appointing a committee to watch and report experience and progress in this most important matter.

Some of the most valuable of the deliberations of a technical organization are those which are arranged for brief consideration, with a prearranged limit to the time to be occupied, and when the subjects are well introduced the result may be not less important than is obtained from elaborate papers or reports. To get the most out of them, however, the subjects need careful selection, and the conduct of the discussion should be such as to insure the briefest and "meatiest" presentation of ideas. When such discussions are intended to bring out the relative importance of the subjects treated, with a view of selection of certain of them for more extended treatment, that plan which will bring out the views of the greatest number of participants should be carefully followed, and exhaustive treatment of the questions should be as carefully avoided.

The apprentice problem has been considered a difficult one, and it was the subject of very earnest painstaking work by the Master Mechanics' Association, the efforts being directed chiefly toward the arrangement of plans for courses through the shops. These are good and necessary as far as they go, but whether an apprentice has or has not the advantage of technical education there is a more important factor than the systematic arrangement of his work. It is of first importance that the officers should interest themselves in the boys, their welfare and instruction. The ideal of education as expressed by Prof. Goss, in the discussion on technical education, before the association (printed elsewhere in this issue), which was elaborated in his admirable lecture, to which we also refer, may be applied equally well in shop practice. The underlying idea in this is to "draw out and make larger men." If this principle inspires the officers when they engage apprentices the question of establishing courses of work solves itself. The courses without the deep interest in the apprentices will fail as they have often failed. We want everyone to read what Prof. Goss said about the technical school training and the spontaneous and extemporaneous statement of the correct view of such education indicates Prof. Goss to be one to whom the guidance of young men may be safely and confidently intrusted. Mechanical railroad officers, inspired by the same idea in regard to shop education, will have no "Apprentice Problem."

BOILER AND STEAM PIPE LAGGING.

Under the title "Best Methods of Boiler and Cylinder Insulation," a committee of the Master Mechanics' Association has presented a report showing that the practice of protecting boilers and cylinders with something else than wooden lagging is increasing, and also showing that the cost of applying good non-conducting materials to boilers and cylinders may be saved in fuel in a single year. The best kinds of lagging will last a long time, and will continue to pay interest on the investment.

Almost simultaneously with the report of this committee comes a most valuable paper before the American Society of Mechanical Engineers upon the same general subject, by Mr. C. L. Norton, of Boston. By this author also it is made clear that the money spent in good laggings is well invested, and the fact is brought out again that magnesia coverings are very near the top of the scale. In the case of the master mechanics' test they are at the top, all of which bears out the position taken previously in these pages.

One very important point seems not to have received the attention that it merits, viz., the lagging of the saddles as well as the cylinders and the boilers of locomotives. This is not mentioned in the committee report referred to, and we think it worth while to call attention to the saddles as being important candidates for the best-known lagging. It is not sufficient to protect the boiler and the cylinder, because some of the steam may become water by condensation on its way between the two. There is no doubt that water in a cylinder not only plays havoc with economical working, but it reduces the power of the engine, and this interferes with economy in the worst possible way. The boiler, the cylinders, the feed and the air pump steam pipes, the cylinder heads and steam chests, and the saddle castings, all ought to be lagged. The saddles are in a very exposed position, and they present such a large radiating surface as to compel attention as a great source of loss of heat, particularly in cold weather. This heat costs as much in fuel burned as any that is produced in the boiler, and we think it costs more than that lost through direct radiation from the boiler itself because of the harmful influence of the water of condensation in the cylinders.

These reports have attracted our attention anew to the relative merits of different kinds of protective coverings, showing that asbestos does not occupy as high a place in the scale as many have appeared to give it. Neither of them has said enough about the fact that physical as well as heat resisting qualities are important in lagging. The covering must not mat or solidify in service to such an extent as to lose its ability to support the jacket and allow it to become buckled or indented. The lagging must be free from injurious chemicals to act on the jacket and corrode it, and also pit the boiler shell. It is important that air spaces should not be left in the covering in such a way as to provide channels for air currents to carry away heat from between the parts of the covering. The question of the best lagging is not by any means settled when the best non-conductor of heat is discovered and that covering is best which is at the same time a poor conductor of heat, a durable close-fitting jacket and a removable coat which may be replaced repeatedly when the engine goes through the shops for repairs. There are such coverings, and they were tested by Mr. Norton and by the committee.

NOTES.

The effect of the length of steam pipes on the economical working of engines was illustrated in a paper by Sir John Durston, Engineer in Chief of the English Navy at the recent meeting of the Institution of Naval Architects, in which it was said that the trials of the "Diadem" showed a saving of from 20 to 30 per cent. of the total coal used by the use of the after boilers, which were those having the shortest steam pipe.

An air motor car on the Hardie plan is to have a trial on the street railroads of Copenhagen, Denmark, the machinery having been built in the United States. The car has two decks seating 48 people. It will weigh 26,000 lbs.

A record of 580 knots in one day was made by the North German Lloyd steamer "Kaiser Wilhelm der Grosse" on her most recent voyage from Bremen to New York. This is the greatest day's run ever made, the best previous record being 566 knots.

The Westinghouse Air Brake Co. has just closed a contract to furnish between \$2,000,000 and \$3,000,000 worth of air brakes to the Manchurian Railway in Russia. This will necessitate the making of these brakes in Russia, and it will probably lead to the adoption of the apparatus on other European railroads.

The railway postal car is finding its way into South America, six cars having been ordered from a Springfield, Mass., firm for shipment to Brazil. While they are to be patterned as much as possible after our own style, they are to be finished in mahogany. The dimensions, of course, will fit the five-foot gauge of Brazil.

Hydrogen has been liquified by Professor Dewar, who has long been studying and experimenting upon the subject. The work was done in England at the Royal Institution, where equipment for experimenting with low temperatures has been installed. On May 10 Professor Dewar announced that he had succeeded in liquefying both hydrogen and helium.

The low cost of steam power at the plant of the Warren Manufacturing Company at Warren, R. I., for a year of 300 10-hour days ending last Fall was \$11.55 per horse-power, including the cost of fuel, wages, supplies, interest and taxes. The engines are vertical cross compound Reynolds-Corliss type built by the E. P. Allis Company of Milwaukee, Wis., and we are informed by the "Engineering Record" that a recent test showed a steam consumption of but 12.44 lbs. per horse-power hour when developing 1,836 horse-power.

A new inertia indicator was explained by Mr. Wilfred Lewis at a recent meeting of the Engineers' Club of Philadelphia. After explaining the difficulties of measuring the inertia of moving machinery by older methods, he exhibited and described an instrument which he had devised for this purpose, which consists essentially of a curved tube filled with water, except for a small bubble of air which moves back and forward in the tube with its acceleration and retardation, caused by the inertia of the body which carries the instrument. By means of a graduated scale placed beside the tube, the inertia may be measured.

Coal Statistics of Pennsylvania for 1897. The following statistics have been compiled by Mines and Minerals, Scranton, Pa., from data furnished to that journal by the State Bureau of Mines and the State Mine Inspectors. The figures are reliable and official, and, as practically all of the anthracite product of the United States comes from Pennsylvania, these statistics give the complete anthracite production for the year 1897:

	Anthracite. (Long tons.)	Bituminous. (Short-tons.)
Tons of coal mined.....	46,947,354	54,674,452
Tons of coke made.....	8,533,291
Persons employed.....	149,557	88,554
Coal mined per employe.....	314	617
Coal mined per miner.....	490	744
Fatal accidents.....	424	149
No. fatal accidents.....	1,106	426
L. lost per 1,000 employes.....	2.83	1.68
L. dents per 1,000 employes.....	7.39	4.81
duction per life lost.....	110,725	366,942
duction per non-fatal accidents.....	42,448	128,344

Compared with the year 1896, these statistics show a decrease in the production of anthracite coal of over a million tons, while the output of bituminous has increased nearly four and one-half millions of tons and the output of coke nearly two millions of tons.

PNEUMATIC TOOLS—THE CHICAGO PNEUMATIC TOOL COMPANY.

The exhibit of the Chicago Pneumatic Tool Company at the Master Car Builders and Master Mechanics' Conventions at Saratoga embodied the latest and most useful improvements in the application of pneumatic power to shop tools. The great interest which was shown in the exhibit was sufficient evidence of the effect of pneumatic shop tools in railroad work. It attracted by far the greatest amount of attention from the railroad men and manufacturers, and was crowded with interested people every day. Several new and exceedingly valuable additions to the tools manufactured and sold by this company have been made since last year, and in a general way our engravings show their variety and the character of the work which they do. One of the engravings shows a general exterior view of the exhibit, the Rand air compressor and storage reservoir being seen at the right in the background, while the other view gives an idea of the machines them-

It has a brass frame and is a compact, handy little machine. The manufacture of car and locomotive jacks for use in yards and shops is a new departure by this company. The exhibit contained one 12 inches in diameter, with a 22-inch lift, having a capacity of 5 tons. Different sizes are made, and the construction is such as to give the greatest possible lift. The cylinder is cast, and the heads held with cap screws, the piston having leather packing. A small two-wheel truck is made to carry the jack by means of trunnions cast on the cylinder. The valve is attached to the top head. Among the new tools is a lathe head, with its spindle driven by a Boyer motor. This head takes Morse taper shanks for chucks, face plates or buffing wheels, and the machine is convenient for many purposes.

A vertical drill, with two solid and one hollow uprights, is also a convenient tool; it is shown in the background at the right in Fig. 2. The drill spindle is extended upward and is driven by a Boyer motor directly connected. The crosshead carrying the lower end of the spindle is counterweighted by a

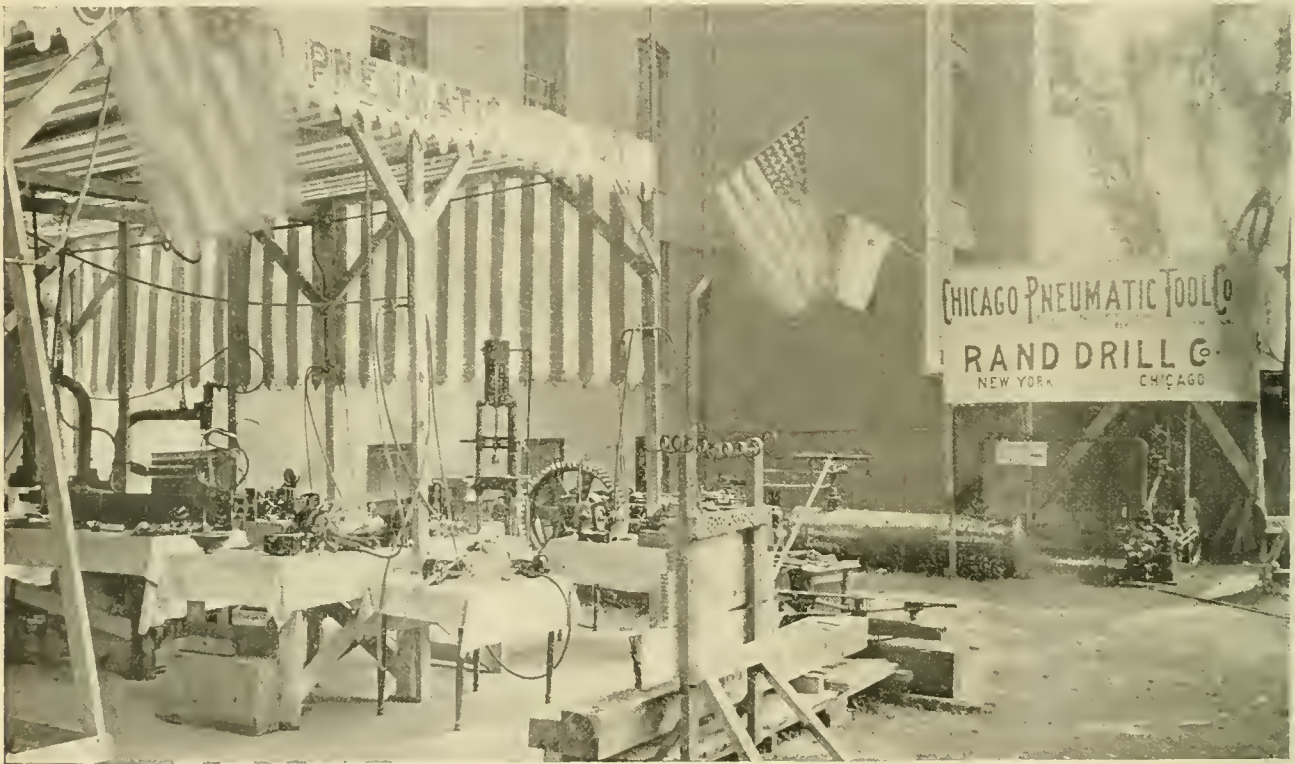

Fig. 1.—Exhibit of the Chicago Pneumatic Tool Co., at Saratoga Conventions.

Work of Wood Boring Tools is shown at center of this engraving.

selves. As we shall illustrate and describe many of these in detail, a general summary only will be given here, which will serve to direct attention to the progress that has been made.

The pneumatic hammers of this concern were the best known of all of their machines, and several sizes for chipping, caulking, flue beading and riveting were shown in operation. The power for chipping was well illustrated by the chipping of a 7-16 inch steel boiler plate in the center of the exhibit, the results of which are shown in the engravings.

Piston air drills of the Boyer three cylinder type were shown, and the application of a new breast drill weighing but 7½ pounds to the boring of wood was interesting. This machine bores holes up to one inch in diameter in wood and to ¾ of an inch in iron. The Whitelaw two piston air drill has an aluminum frame, and one weighing but 8½ pounds bores holes up to 3 inches in diameter in wood and 1¼ inches in iron. The Whitelaw single piston oscillating cylinder breast drill, weighing but 6 pounds and drilling holes up to ¾ of an inch in iron, is used for drilling the test holes in staybolts.

weight running in the hollow support of the machine, consisting of a 3-inch pipe. The work table may be raised or lowered by gears and clamped in any desired position.

At the left of the drill press, in Fig. 2, is a McIntosh improved flue welder, adapted to swage, open and weld tubes of 2, 2¼ and 2½ inches diameter. The hammer of the machine is driven on its downward stroke by air pressure and returned by a spring.

This company now manufactures a light, convenient pneumatic painting machine, which we should say would hold about 1½ gallons. It is intended for painting or whitewashing, and is held in one hand while operating. The Boyer speed recorder is too well known to require description. One was rigged to be run by a Boyer motor, to show its operation.

The heavy pneumatic hammers used as riveters have made wonderful progress in bridge and shipbuilding work. The yokes are of light sections, sometimes of 3½-inch pipe, and sometimes of light trussed angle construction. The frames have gaps of from 15 to 84 inches, and rivets up to 1 and 1½ inches

are closed rapidly and satisfactorily. Sectioned samples of riveting showed the work to be excellent, and superior to a great deal of hydraulic riveting that we have seen.

Our readers are familiar with the Manning sand-papering machine, which is one of the earlier applications of air motors to wood work. If they are not equally familiar with the new flue cutter and roller they should take the earliest opportunity to see it in operation. The motor of this machine gives $3\frac{1}{2}$ horse power, and it may be used in many kinds of work, being portable and convenient to operate. One of these machines was belted to an Ajax forging machine of a capacity of $2\frac{1}{2}$ inch bars of iron or steel. The motor seemed ridiculously small to be running the massive forging machine, but it was doing it easily.

The Whitelaw staybolt cutter or "biter" is new and is a money saver in cutting off the ends of staybolts. The capacity of the present machine is $1\frac{1}{8}$ inches, but another, nearly ready, will cut $1\frac{1}{2}$ -inch material. The list of devices was completed by a Curtis cylinder 1,500-pound air hoist, with a lift of 4 feet. The capacity and lift may be made to suit requirements, and all sizes are fitted with check valves to hold

Company against the E. G. Bernard Company and others, and was instituted by the General Electric Company, and defended by Messrs. Siemens & Halske. The basis of the suit was Thomas A. Edison's patent No. 261,668, for an improvement in regulating the generative capacity of dynamos, and the basis of the defense was Brush's invention and patent preceding Edison's work on commercial machines, and which, as stated in the opinion of the court, anticipated the patent granted to Edison.

The importance of this decision is very great, and concerns all manufacturers of dynamo-electric machinery, and it is stated by interested persons that had the suit been decided in favor of the General Electric Company it would have subordinated nearly all of the electric railway generators and also the direct lighting work in this country. The opinion is much too long for us to reproduce. Edison's specification says:

The object of this invention is to produce means by which the addition or removal of translating devices in the multiple-arc circuits of a system of electrical distribution shall cause immediately a proper regulation of the current energizing the field magnet of the dynamo-electric machine supplying such system, and this without the use of adjustable resistances, or of any mechanism whatever, except the ordinary circuit controllers of the lamps.

The opinion shows that the earliest date assigned for the conception of the Edison patent was August 19, 1879, and the date of Brush's patent was July 22 of the same year. Edison's

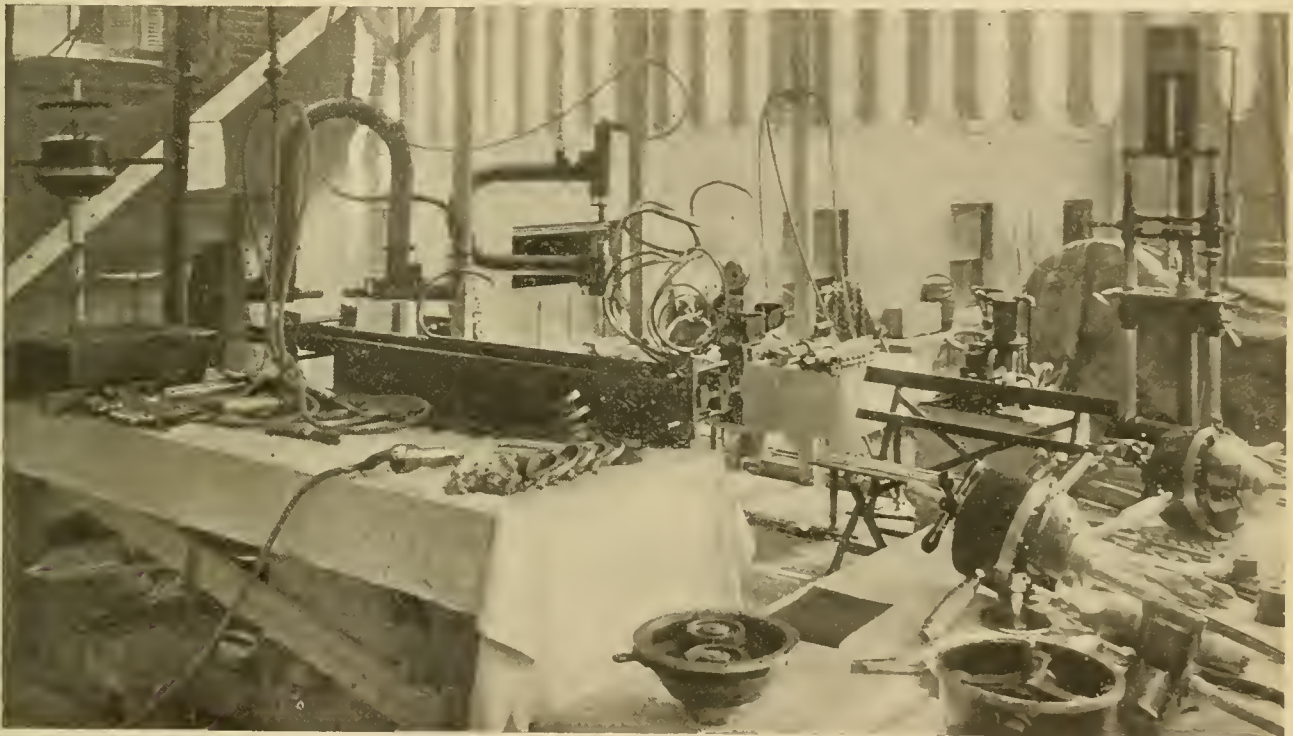

Fig. 2—Exhibit of the Chicago Pneumatic Tool Co., at Saratoga Conventions.

Work of the Chipping Hammers on $\frac{3}{16}$ -in. Boiler Plate is shown at the center of this engraving.

the load if the hose bursts. These hoists have equalization pipes to prevent drawing air with dust from the shop into the cylinder.

Power to run these tools was furnished by a 10x14-inch straight line Rand compressor mounted on two 8x8-inch timbers set in the ground in lieu of a foundation. An automatic unloading device regulates the operation of the compressor to suit the consumption of air. The volume of the cylindrical storage reservoir used in this case was about 30 cubic feet.

The more interesting and novel of these machines will be illustrated in a later issue.

REGULATION OF COMPOUND WOUND DYNAMOS.

A very important and far-reaching decision has just been handed down by the United States Circuit Court of the Northern District of New York in what is known as the "Compound Wound Dynamo Suit," constituting a great victory for the Siemens & Halske Electric Company of America, the defendants. The suit was brought by the Edison Electric Light

machines made at the time of his patent did not operate satisfactorily and never were commercially successful. The defense was lack of novelty and invention, and non-infringement and the lack of novelty was based on the Brush patent just referred to. The court says:

"The proof shows that a number of machines were built pursuant to its (the Brush patent) directions, and were commercially used more than two years prior to the date of the application for the Edison patent. These machines exist at the present day, and what is quite remarkable and almost unique in patent litigation is the fact that in an art which has progressed with giant strides, machines made nearly twenty years ago are not only operative, but practically as successful as when first built. Two of these working dynamos have been introduced in evidence, one by the complainant and one by the defendants. Each is capable of doing the same work now as in 1880."

The bill was dismissed, and the defendants are to be congratulated on the result of the suit.

Mr R. H. Soule will represent the Baldwin Locomotive Works at Chicago after July 1, and Mr. C. A. Thompson of St. Louis will act as Southwestern representative.

A PASSENGER LOCOMOTIVE TRUCK—THE J. G. BRILL COMPANY.

An experiment in electrical railroad work is being tried in France which in many respects is more like Yankee than French engineering. The idea is to construct an electric passenger locomotive which shall not only haul a train, but shall carry passengers as well. It is to be carried out upon a scale and in a manner which has never been attempted in this country, an ordinary electric car hauling a trailer is the limit of American work in this line. The French proposition is to build a moderate-sized double truck passenger coach weighing complete 96,000 pounds, and provide it with sufficient motive power to utilize the adhesion obtained by this weight. The line is some 200 miles in length, and express speed is to be maintained. The car body for this machine was built in France, and only a few details are at hand in regard to it. The floor frame is of channel bars. It is 36 feet 9 inches long and 6 feet 9 inches wide. The channels are apparently about 10 inches deep. No details whatever are given in regard to the body, which is carried by a pair of "Perfect" trucks (The J. G. Brill Company's No. 27) of the type especially designed to meet the requirements of steam passenger cars. These

are 7 feet 6 inches long, and 5 inches in diameter at the wheel fit. The journals are $4\frac{1}{4}$ by 8 inches. Each truck is furnished with a pair of 150 horse power motors, thus giving the car 600 horse power. The trucks weigh 11,080 pounds each. The motors 10,000 pounds per pair, and the car body 24,000 pounds. This brings the weight without passengers up to a little more than 66,000 pounds. Lead or iron ballast will be used to get the required load of 96,000 pounds.

An entirely new departure has been made in the locomotive truck for the French car. Ease of riding was considered of the utmost importance, and it was determined to make it ride as smoothly as a carriage should, while at the same time it possessed all the necessary features of strength, stiffness and durability. In the production of an easy riding carriage the initial step was the introduction of journal springs over the boxes. The first advantage of this is the reduction of the weight not carried by springs, which now consists of wheels, axles and boxes only. The heavy equalizer, instead of resting directly on the boxes, is carried by the open links, in which another set of springs are introduced. The latter have the same capacity as those on the journal boxes, and have a double function, cushioning the equalizing movement where the wheel rises, and cushioning the swing motion when the

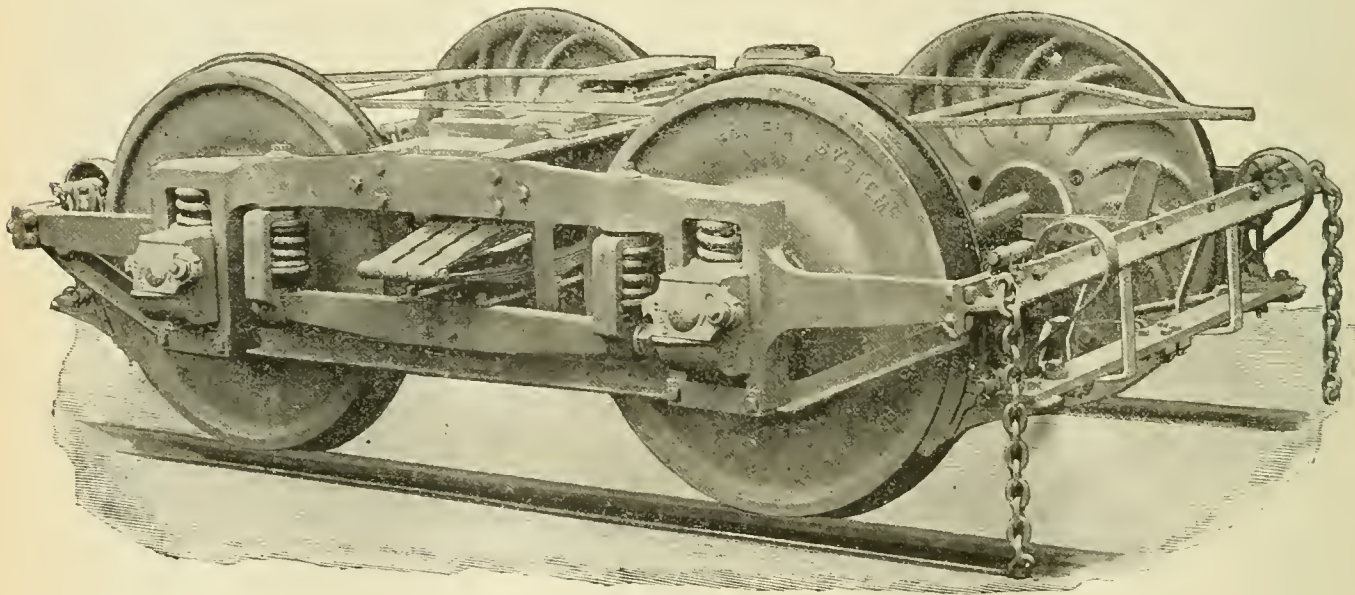

Brill Truck for Electric Passenger Locomotive.

trucks are quite as great a departure from the common order as the scheme for the car itself. One of them is shown in the illustration.

The trucks must perform all the essential work of a locomotive. Their second function is that of a railway carriage. The car and the machinery must be carried without shocks or disturbance, curves must be passed smoothly and without danger, and the load must not exert a destructive action upon the roadbed.

To meet the requirements of the locomotive alone the trucks are built in the most substantial manner. The side frames, which also form the jaws for the journal boxes, are heavy forgings nearly as large as the bars of a locomotive frame. They are deeper, but not as thick. The end pieces of the frame are T irons, carried by palms worked upon the side pieces. The seats in these palms are finished and the holes are reamed for taper bolts. Locomotive practice is followed in constructing the trucks, and wherever bolts are used they are made taper, and the holes are reamed. The swing bolster is held between a pair of angle iron transoms, which are bolted to the side frames of the truck. The ends of the angle are cut out and bent so as to form brackets for the purpose. The wheels are of unusual size, being 45 inches in diameter. They are of cast iron, and are mounted upon very large axles. These

truck moves sidewise. The equalizing bar forms a part of the swing motion, and is firmly attached at its center to the spring plank. The links by which it is carried are attached to the wheel piece a short distance from the centers of the journal boxes. The hanging of these links consists of a large bar carrying a spring seat upon the lower end, while the upper post terminates in a square head, under which a ball or hemisphere is finished, forming, with a hemispherical cup in the solid frame, a ball and socket joint. The hole beneath is made sufficiently large to allow the bar the required swing. This construction gives an extra link, as no room is taken up by the hinge. Upon the spring plank there are two sets of triple elliptic springs. Quadruple springs would have been preferable, but in this case the contract limited the wheel base to 6 feet, and there was only room for the triple springs.

The steadiness of these trucks under the action of the brakes is a valuable feature. On account of the changed relationships between the bearing points and the suspensions of the equalizers at the ends, with the weight actually central, these trucks do not tilt under the action of the brakes, no matter how hard they may be applied.

As shown in the engraving, this truck is substantially the form of "Perfect" truck which the Brill Company recommend for steam passenger service. It is fitted with the M. C.

B. standard box, and in other respects would conform to the standard. The brake rigging is nearly the same as that used on heavy steam car work. The brake beam in this case is a heavy flat bar trussed for strength, but the brake hangers, springs, straps, etc., are like those used on steam road trucks. It should be noted that the double brake rod shown in the cut is a feature introduced for the purpose of clearing the motors, which come up very high. The brake levers could not be inclined because the French guard rails are high and fill the whole space between the rails, except a small opening in the center, which was the only place for the lower rod. By using pipe the double rod was made quite light.

SUSPENDED VS. SUPPORTED JOINTS.

The following paragraphs are reproduced from a communication from Mr. C. P. Sandberg to "Engineering":

It is now about 30 years ago since the suspended rail-joint was introduced. During these 30 years I have done my share to improve the suspended rail-joint by adopting angular and deep fishplates, so as to give the rail-joint the same stiffness as the solid rail. Since then it has been found that the supports were to be more relied upon to keep the joints up than any design of fishplates, so the joint sleepers have been brought together more and more, now only leaving the space absolutely necessary for packing. Thus I have arrived at the so-called Goliath joint. This was applied to my 100-lb. rail, which has now been seven years in service in St. Clair's tunnel, Canada, with good results. It has also been down on the Furness Railway for seven years, near Barrow, for trial in comparison with the English type of road, where it may now be seen giving satisfactory results. Last year this rail-joint was adopted on the Swedish State line for my 90-lb. rail. It gives the best line for the least money compared with the main lines in Europe, and it may thus be taken for the best type of the suspended joint. The larger bearing surfaces which my new rail sections offer have been of material advantage in supporting the joint, but although it carries the same load in testing as the solid rail, good ballasting is required to give good results. The use of coarse stone ballast has proved to be the best means of keeping the joint up, but it is very expensive, and in some localities it is almost impossible to obtain.

It is therefore important to find a design of joint, whether supported or suspended, that will give the best road with ordinary ballast and maintenance. I have designed a three-sleeper supported rail-joint, with angular fishplates for the same rail as the Goliath suspended joint. The weight of the fishplates for both joints is about the same, but the fishplates for the Goliath joint have spike holes and direct bearing on the sleeper, while for the supported joint they have slots to prevent creeping of the rails.

To prevent the flattening of the rail ends, the steel has been lately increased in hardness by chemical composition, particularly by carbon; but the International Railway Congress, held in London, 1895, refused to confirm a former resolution to the effect that a harder steel should be recommended. On the contrary, the majority stated that the question is not sufficiently matured, and the English engineers particularly were in favor of a rail steel of medium hardness.

Bearing in mind that the harder the rail the more it is apt to break in many pieces when weakened by long service, it would be a dangerous practice to resort to excessive hardness, particularly in countries with cold climates. The slight gain in hardness between .45 and .55 per cent. carbon is more than balanced by the greater risk of fracture, and such means should only be resorted to with great caution, and after all has been done in the direction of improved joints, best ballast obtainable, and the most careful maintenance.

The supported rail-joint has now a greater chance in competition with the suspended one than 30 years ago, for not only is it supported by three sleepers, instead of one, but both fishplates and rails can be rolled with flatter and sharper bearing surfaces than formerly, which is of great service in holding up the joint, if the designer of the rail sections has taken advantage of this progress in rolling steel.

Even in England the supported joint is gaining ground, and several railways are trying it, for instance, the London & Northwestern are trying Webb's patent chair. The London, Chatham & Dover Railway adopted joint chairs some time ago, and they are now generally used on their system and give satisfactory results.

Regarding the increased weight of rails, it is no doubt very good also for the joint, but it is not sufficient to increase the weight alone; the material must also be distributed in a good rail section for fishing. This is often overlooked, and the expected advantages of a heavier rail are not then realized.

At the last International Congress it was decided that where express trains were run with a speed of 50 miles or more per hour, the weight of the rails should be 80 pounds or more per yard. When I, in 1886, suggested my 100 pounds per yard section to the Belgian State Railways, I was considered extravagant. The three largest railways in England have now increased the weight of their rails to 100 pounds or to 103 pounds, besides having a chair weighing about 50 pounds, which should improve the joint in proportion.

THE WESTINGHOUSE COMPANY BUYS THE BOYDEN BRAKE.

The "New York Commercial" of June 27 prints the following: "At a meeting yesterday of the stockholders of the Boyden Brake Company an offer from the Westinghouse Air-Brake Company to buy out the Boyden Company was accepted unanimously. The price named was \$900,000. This sum will pay off the floating debt and the preferred stock of the Boyden company, and besides net the holders of the common stock \$25 a share. The common stock of the company amounts to \$3,000,000.

"At the meeting a committee composed of Messrs. Douglas H. Thomas, Charles D. Mann and Theodore G. Lurman was appointed to conclude the sale. It is said it will take four or five months to conclude the transaction.

"The action of the stockholders of the Boyden company closes one of the most notable patent cases in the history of the country. The fight between the Boyden and Westinghouse companies was hotly contested. The Westinghouse, which had enjoyed a monopoly of the air-brake business before the Boyden invention, claimed that the latter was an infringement on their patent on quick-acting brakes. The case was taken to the Supreme Court of the United States. The decision was rendered upholding the claims of the Boyden company."

MAGNOLIA METAL COMPANY WINS A SUIT.

The Magnolia Metal Company, manufacturers of the well-known "Magnolia" anti-friction bearing metal, informs us that they have secured a permanent injunction in the United States Circuit Court for the Southern District of New York, before Judge Wallace, against Benjamin and Moses Lowenstein, trading under the firm name of the Nassau Smelting and Refining Company of New York, restraining them from offering for sale or advertising "Magnolia Anti-Friction Metal." The decree of the Court is as follows:

"Ordered, adjudged and decreed that the complainant, the Magnolia Metal Company, is the owner of a good and valid trade-mark, consisting of the word 'Magnolia,' as applied to anti-friction metals and alloys made and sold by it, and is entitled to the sole and exclusive use thereof, and that the defendants, Benjamin Lowenstein and Moses Lowenstein (trading as the Nassau Smelting and Refining Co.), have, by the use of the word 'Magnolia' upon anti-friction metal made and sold by them, violated and infringed upon the exclusive rights of the complainant in the premises; and it is further ordered, adjudged and decreed that the defendants, Benjamin Lowenstein and Moses Lowenstein, and each of them, their and each of their attorneys, agents, servants, clerks, salesmen and employees and each of them, and all persons acting under them or their authority by, and they hereby are perpetually enjoined and restrained from infringing the complainants' said trade-mark and rights; and from marking, designating or advertising an anti-friction or other like alloy or metal as 'Magnolia;' and from using on any alloy or metal for anti-friction or like purposes, or in conjunction with manufacture or sale thereof, the word 'Magnolia,' or any other word calculated to deceive the public by a like close imitation of the complainants' trade-mark 'Magnolia;' and it is further ordered, adjudged and decreed that the complainant recover from the said defendants, as well, the damage sustained in or by reason of said infringement as the profits, gains and saving made or realized by the defendants thereby."

For the past eight months the Baltimore & Ohio Railroad has been keeping an accurate account of the tons carried per train mile on the entire system in order to ascertain to what extent the improvements had increased the train haul. The results have more than justified the expectation as the average for the eight months ending Feb. 28 is 323.13 tons per train mile. This is certainly a good showing, as the average in years gone by has not exceeded 225. The average for the year will doubtless be much larger.

EQUIPMENT AND MANUFACTURING NOTES.

The Baltimore & Ohio Railroad carried 28,663 persons in special parties during the month of May, not counting regular and Decoration Day passengers. Of this number 19,000 were troops en route to Falls Church and Chickamauga.

An affiliation between the Niles Tool Works and the Pond Machine Tool Works is announced. This deal does not appear to be a consolidation, but it is sure to result in improvement in the condition of the heavy tool business. It is also announced that new works are to be built at Berlin, Germany, to be known as the Deutsche Niles Werk-zeug Maschinen Fabrik. This means a Niles works in Germany.

The Baltimore & Ohio is introducing a great improvement in the accommodations for women in the new parlor cars recently built for the trains of the Royal Blue Line between New York and Washington. Three of these cars which are now in service contain ladies' retiring rooms. These apartments are 8 feet long, and are provided with full-length mirrors, cushion settees, stationary dressers, book-cases and all possible conveniences that can be found in a ladies' boudoir. The finishing is artistic and beautiful. The new cars are the longest of the kind ever built, being 70 feet in length, exclusive of platforms.

The Ashton Valve Company, of 271 Franklin street, Boston, has sent us the most attractive desk blotter we have ever seen. It bears a good half-tone portrait of Admiral George Dewey, and "Old Glory" and the Cuban flag embossed in colors with the seal of the United States in colors and gold over the crossed staffs of the flags. It is a good blotter, but is too handsome to be used in that way.

"Chicago Rabbeted Grain Doors" were specified on 200 box cars for the Chicago, Rock Island & Pacific, and 500 cars for the Canadian Pacific, building at the shops of the roads. The "Security Lock Brackets" are to be used on the Canadian Pacific cars, and also on the following cars contracted for in the month of May: 1,000 cars for the C., C. & St. L. Ry., building at Pullman; 500 cars for the Rock Island, by the Michigan Peninsular Car Company; 500 cars for the "Soo Line" and 1,000 cars for the Illinois Central.

The proper lubrication of gas engine cylinders has been a very difficult problem. The problem, however, seems to have been very successfully solved by an official of the Pennsylvania Railroad Company. He writes as follows: "I had a gas engine at Sharon, Pa., running a pump, and the man who had charge of it allowed the lubricator to run dry and cut the piston, piston rings and cylinders. The makers of the gas engine said the cylinder would have to be sent to the shop and bored out and a new piston put in. It was our busy season and we could not do without water. I had some of Dixon's finely pulverized graphite, and I commenced to feed it into the cylinder through the suction pipe with the air and gas, with immediate relief. After about two weeks the engine was running smoother and using less gas than ever before. I had this same engine apart last Saturday, and every place that was cut is smooth as glass. This one instance saved us about \$75. I have great faith in this graphite, and always keep it on hand."

The "Diamond S" brake shoe patents are now owned by the American Brake Shoe Company, of which Mr. W. D. Sargent is President. This company was organized for the purpose of maintaining a careful inspection of the product of all of the licensees under these patents, and to insure uniformity of manufacture throughout the country, so that the railroads using these shoes will be guaranteed a continuance of the good results obtained from these shoes as manufactured by the Sargent Company. An inspection of shoes in service will be maintained in order to give the roads the benefit of the services of the company's experts. The licensees are as follows:

The Sargent Company—Old Colony Building, Chicago, Ill.; Security Building, St. Louis, Mo.; Endicott Arcade, St. Paul, Minn.; 537 Mission street, San Francisco, Cal.

The Ramapo Iron Works—Hillburn, N. Y.; Havemeyer Building, New York, N. Y.

Parker & Topping—Endicott Arcade, St. Paul, Minn.; Albina Foundry, Portland, Ore.

Central Brake Shoe Company—Ellicott Square, Buffalo, N. Y.; Havemeyer Building, New York, N. Y.

PAMPHLETS RECEIVED.

"Purdue University; Announcement of Courses in Railway Engineering and Railway Management, 1898-99."

This pamphlet contains a general announcement of the department devoted to railway engineering and railway management, a statement of courses of study and practice and engineering research, a detailed statement of equipment and lists of officers and lecturers, who are to present the practical side of railroad work to the students during the coming college year. The pamphlet will interest prospective students and all who are concerned in the adaptation of college instruction to the subject of railroads.

Brill Standard Sprinkling Cars. An illustrated 8-page pamphlet, issued by the J. G. Brill Co., Philadelphia, Pa., May, 1898. The Brill standard sprinkling cars are described and illustrated, information in regard to capacity, sizes and fixtures, pumps and separate motors, enclosed tanks and the value of sprinklers being given. The standard sprinkling car consists of a 2,500-gallon tank mounted on a solid seasoned oak frame and carried on a solid forged frame four-wheel truck with double spiral springs at each box. This amount of water will sprinkle from $5\frac{1}{2}$ to 8 miles of road. The sprinklers are specially designed to prevent obstructions. Other sizes of tanks and other arrangements of the car, including suction pumps and separate motors are provided when required.

INSPECTION OF WOODEN BRIDGES.

In an address at a recent meeting of the employees of the bridge and building department of the Chicago, Milwaukee & St. Paul Ry., Mr. William Gannon gave the following account of the method of inspecting wooden bridges on that road: Wooden bridges should be inspected twice a year, the best time being in the spring and the fall. Those who inspect should have knowledge of the life and strength of timber, parts most apt to decay and places most liable to pull or strain apart. Our mode of inspection is to have a crew consisting of the district or chief carpenter, foreman of bridge crew, three bridge carpenters and the bridge inspector, with a light hand car. The tools we take with us are. Three sharp-pointed bars; 3 braces; 4 auger bits, one-half inch by 2 feet 6 inches over all; 2 hand axes; 1 square; 1 hand saw; 1 shovel; 1 chisel; 1 extension pike pole; 2 pounds nails. We look all bridges over carefully, and on pile bridges two men take the sharp-pointed bars and try the piles from 2 to 3 inches below the surface of the ground, calling attention to any piles that have only 6 inches or less of good timber in them. The inspector and the balance of the men look the caps, stringers and ties over, and the Inspector and District Carpenter decide the amount of boring and in what places it should be done. On Howe truss span bridges we look them over carefully, and when they are over 5 years old test them with a bit and sound the timber with a bar or a hand ax; the older the bridge is the more it is tested.

EXHIBITS AT THE CONVENTIONS.

The following is the list of the companies exhibiting at the recent conventions at Saratoga:

Adams & Westlake, Chicago, Ill.
Allan-Morrison Brake Shoe Company, Chicago. Composite brake shoes.

American Brake Shoe Company, Chicago, brake shoes and tinted picture showing those parts of a locomotive which have been made of cast steel.

Ajax Mfg. Co., Cleveland, O.
Anglo-American Varnish Company, Newark, N. J.
Ashton Valve Company, Boston, Mass. Ashton standard muffler safety valves, Ashton adjustable ring muffler safety valves, Ashton open pop safety valves, both plain and with cam lever; Ashton double spring locomotive steam gages, Ashton double spring duplex air gages.

American Steel Foundry Company, St. Louis, Mo. Models of the American steel truck and bolster.

Bird & Son, F. W., East Walpole, Mass, car roof.
Bushnell Manufacturing Co., Easton, Pa. Car seats.
Boston Belting Co., Boston, Mass. A full line of hose, rubber packing and mechanical rubber goods.

OUR DIRECTORY

OF OFFICIAL CHANGES IN JUNE.

Boston Woven Hose and Rubber Company, Boston and Chicago. Rubber Hose.

Buck Manufacturing Co., St. Louis, Mo.

Buckeye Malleable Iron and Coupler Co., Columbus, O.

Burrows Co., The E. T., Portland, Me. Car curtains.

Chicago Railway Equipment Co., Chicago. National Hollow Brake Beams, automatic frictionless side bearings and air-brake controller.

Chicago Pneumatic Tool Co., Chicago and New York. Pneumatic riveters, hammers, hoists, staybolt nippers, sand papering machines, painting machines, drill presses, flue rollers and reducer and speed recorder.

Cleveland City Forge & Iron Co., Cleveland, O. Turnbuckle for "the coming car."

Cloud Steel Truck Co., Old Colony Building, Chicago. Cloud pressed steel truck and Bettendorf I beam body and truck bolsters.

Corning Brake Shoe Co., Corning, N. Y. Brake shoes.

Crosby Steam Gage & Valve Co., Boston, Mass.

Davis Pressed Steel Co., Wilmington, Del. Davis tight-joint journal box.

Detroit Lubricator Co., Detroit, Mich. The Detroit Lubricator.

Diamond Rubber Co., Akron, O., air brake hose and a complete line of railway rubber goods.

Facer Forged Steel Car Wheel and Locomotive Wheel Co., Germantown, Pa. Steel forged wheels for locomotives and cars.

Fox Pressed Steel Equipment Co., New York. Models of the Fox truck.

Gold Car Heating Company, New York, complete car heating equipment under steam pressure.

Goodwin Car Co., New York, photos showing Goodwin dump car.

Gould Coupler Co., New York and Chicago. Automatic car coupler.

Hale & Kilburn Mfg. Co., Philadelphia, Pa.

Hancock Inspirator Co., Boston, Mass. Hancock inspirator in four types, boiler checks, hose strainer and a large ejector.

Hammitt, M. C., Troy, N. Y., Stevenson belt dressing.

Homestead Valve Mfg. Co., Homestead, Pa. Valves.

Joyce, Crippland & Co., Dayton, O.

H. W. Johns Manufacturing Company, New York.

Keystone Axle Co., Pittsburgh, Pa.

Knitted Mattress Co., Canton Junction, Mass., seat mattresses.

Lackawanna Lubricating Co. Scranton, Pa. Lubricators.

Leach, Henry L., North Cambridge, Mass. Pneumatic sander.

McCord & Co., Chicago. Journal box and hopper bottom door.

Mason Regulator Co., Boston.

Massachusetts Mohair Plush Co., Boston, Mass.

Manning, Maxwell & Moore, New York. Metropolitan injector, consolidated safety valve and Ashcroft gage.

Michigan Malleable Iron Co., Detroit, Mich. Solid couplers and Thornbergh coupler detachment.

Monarch Brake Beam Co., Detroit. The Monarch and the Solid freight and passenger brake beams.

McVicar & Sweet, Denver, Colo., McVicar oil cups.

National Elastic Nut Co., Milwaukee, Wis.

New York Belting & Packing Co., Ltd., New York.

Norton, A. O., Boston, Mass., Norton jacks.

National Malleable Casting Co., Cleveland, O. Tower coupler with lock set.

Ohio Falls Car Mfg. Co., Jeffersonville, Ind. Buckeye steel truck.

Oval Brake Beam Co., Philadelphia, Pa., brake beams.

Pantasote Leather Co., New York, car curtains, car seats and car headlinings.

Peerless Rubber & Mfg. Co., New York, a full line of mechanical goods, including rainbow packing.

Pottier & Stymus Co., New York, car seats.

Pratt & Letchworth Co., Buffalo, N. Y., cast steel wheel centers, driving boxes and crossheads and malleable iron journal boxes, Pooley couplers, and other freight car castings.

Q. & C. Co., Chicago, brake slake adjuster and Wood seal lock. Pneumatic tools, Stanwood steel step.

Rand Drill Co., New York, 30 H.-P. air compressor.

Reed Mfg. Co., Erie, Pa. Pipe wrench.

Richmond Locomotive Works, Richmond, Va., compound locomotive on D. & H. tracks.

Rochester Automatic Lubricator Co., Rochester, N. Y., automatic lubricator.

Safety Car Heating & Lighting Co., New York.

Schoen Pressed Steel Co., Pittsburgh, Pa., pressed steel cars.

Simplex Railway Appliance Co., Chicago, truck and body bolsters.

Sellers, Wm., & Co., Philadelphia, Pa., check valve, automatic injector and strainer.

Standard Car Truck Co., Old Colony Building, Chicago, Ill., standard car truck.

Standard Coupler Co., New York, Standard Steel platform and standard couplers.

Sterlingworth Railway Supply Co., Easton, Pa., Sterlingworth brake beams and steel trucks.

Universal Car Bearing Company, New York, Car Bearing.

Westinghouse Air Brake Co., Pittsburgh. Westinghouse Friction Draft Gear and Automatic Air and Steam coupler, on exhibition on cars on D. & H. tracks.

Westinghouse Machine Co., Pittsburgh. Three cylinder, 55 H.-P., gas engine, direct connected with electric generator.

Wheeler Car Seat Co., Chicago, car seats.

Adirondack.—Mr. James J. Traver, formerly Master Car Builder of this road, died May 20, at the age of 82 years.

Baltimore & Ohio System.—Mr. James Fitzgerald, Vice-President of the Staten Island Railroad, which is part of this system, died at his residence in New York City May 26, at the age of 60 years.

Bangor & Portland.—Mr. C. A. Ward has been appointed Master Mechanic, with office at Bangor, Pa., succeeding Mr. George Holmes.

Central Ontario.—Mr. H. S. Johnson has been elected Vice-President, vice H. P. McIntosh.

Central Railroad of New Jersey.—Mr. J. R. Slack has been appointed Mechanical Engineer.

Chesapeake & Ohio.—Mr. H. Frazier has resigned as Chief Engineer.

Chicago, Rock Island & Pacific.—Mr. Warren G. Purdy has been elected President. He was formerly First Vice-President. Mr. R. H. Cable declined a re-election to the Presidency, and was elected Chairman of the Board of Directors. Mr. W. H. Truesdale was chosen First Vice-President. He was formerly Second Vice-President and General Manager.

Chicago Terminal Transfer.—Mr. Edward D. Adams has been elected President and Chairman of the Executive Committee, and Mr. S. R. Ainslie, Vice-President and General Manager.

Columbus, Sandusky & Hocking.—Mr. J. W. Stokes has been appointed Master Mechanic, with headquarters at Columbus, Ohio. He was formerly Master Mechanic of the Illinois Central.

Detroit & Lima Northern.—Mr. C. W. Taylor has been appointed Purchasing Agent, succeeding Mr. C. H. Roser. His headquarters will be in Detroit, Mich.

Detroit & Milwaukee.—Mr. Benjamin Briscoe, formerly for many years Master Mechanic, died May 2, at the age of 86 years.

El Paso & Northeastern.—Mr. C. F. Winn, formerly Joint Foreman of the Denver & Rio Grande and the Rio Grande Western, at Durango, Cal., has been appointed Master Mechanic of the E. P. & N. E., with office at El Paso, Tex., succeeding Mr. George F. Miller.

Pitchburg.—Mr. J. W. Marden has been appointed Superintendent of Motive Power, to succeed Mr. John Medway.

Fremont, Elkhorn & Missouri Valley.—Mr. Carey Turner has been appointed Assistant Master Car Builder, with headquarters at Omaha, Neb. He was formerly employed in the car department of the Central Branch shops, at Atchison.

Great Northern.—Mr. J. F. Stevens, for the past three years Chief Engineer, has tendered his resignation, on account of ill health.

Great Northern.—President James J. Hill announces that the vacancy caused by the resignation of Mr. W. H. Newman to accept the Presidency of the Lake Shore & Michigan Southern, will not be filled.

Indiana, Illinois & Iowa.—Mr. F. P. Shonts has been elected President. He was formerly General Manager. He succeeds Mr. Drake.

Interoceanic.—Mr. L. H. Sherman has resigned as Master Mechanic, at Pueblo, Mex., and has returned to his former home, Houston, Tex.

Illinois Central.—Mr. L. L. Dawson has been appointed Master Mechanic of the Illinois Central shops, at Memphis, Tenn.

International & Great Northern.—Mr. Leroy Trice has been elected Second Vice-President, succeeding H. B. Kane. Mr. Trice also continues to be General Superintendent.

Leavenworth, Kansas & Western.—Mr. Horace G. Burt is President, with office at Omaha, Neb.

Lake Shore & Michigan Southern.—President Newman of this road announces that Mr. W. H. Canniff having resigned as General Manager, that office has been abolished, and Mr. P. S. Blodgett, in addition to his present duties, as General Superintendent, will have charge of such matters as have heretofore been under the jurisdiction of the General Manager. Mr. P. P. Wright, Assistant General Manager, will continue to discharge the duties heretofore assigned to him.

Missouri, Kansas & Texas.—Mr. John N. Simpson, Third Vice-President of this road, has been elected Second Vice-President.

Manistique & Northwestern.—Mr. Abijah Weston, President of this road, died at Tonawanda, N. Y., June 6, at the age of 75 years.

Minneapolis, St. Paul & Ste. Marie.—Mr. Thomas Green has been appointed Acting Chief Engineer, vice W. W. Rich, previously Chief Engineer.

New York Central & Hudson River.—Mr. W. J. Wilgus has been appointed Engineer of Maintenance of Way, with headquarters in New York, and the office of Chief Assistant Engineer has been abolished.

Norfolk & Southern.—Mr. Herbert Roberts has been appointed Superintendent of Motive Power, succeeding Mr. G. R. Joughins.

Northern Central.—Mr. Daniel S. Newhall, the new Purchasing Agent of the Pennsylvania, was elected to the same office on

this road at the election held on June 4 in Philadelphia. Mr. Lewis Neilson was elected Assistant Secretary, to succeed Mr. Newhall.

Ogdensburg & Lake Champlain.—Mr. Theodore Butterfield has been appointed General Manager, with office at Ogdensburg, N. Y. Mr. C. G. Chevalier has been appointed Purchasing Agent, with office at Ogdensburg, N. Y.

Pittsburgh & Lake Erie.—At a special meeting of the Directors of this company, which is controlled by the Lake Shore & Michigan Southern, Mr. W. H. Newman, the new President of the L. S. & M. S., was unanimously chosen President. Mr. Callaway, the new President of the New York Central, was heretofore President of the P. & L. E.

Pennsylvania.—Mr. Daniel S. Newhall has been chosen Purchasing Agent by the Board of Directors, to succeed Mr. A. W. Sumner, deceased.

Richmond, Fredericksburg & Potomac.—Mr. J. S. Cooper has been appointed Master Mechanic, with office at Richmond, Va., to succeed Mr. J. T. Bryant, deceased.

Santa Fe Pacific.—Mr. T. F. Underwood has been appointed Master Mechanic, with headquarters at Winslow, Ariz.

St. Louis, Peoria & Northern.—Mr. J. W. Hemphill has been appointed Master Mechanic, with headquarters at Springfield, Ill., vice Mr. A. L. Moler.

Seivern & Knoxville.—Mr. R. A. Springs is President of this road, which is operated by the officers of the Carolina Midland Ry.

St. Louis, Peoria & Northern.—Mr. Alexander Rumpler has been appointed Assistant to the President. He was formerly Assistant to George W. Stevens, Superintendent of Motive Power of the Lake Shore & Michigan Southern. His office will be at St. Louis, Mo.

Temiscouata.—Mr. E. D. Boswell, President of this road, died at Riviere du Loup, Quebec, June 3, at the age of 50 years.

Utah Central.—Mr. George G. Bywater, formerly Master Mechanic of this road, died May 16, at the age of 69 years.

Washington County.—Mr. William Barkley Parsons has been appointed Chief Engineer. He succeeds Mr. G. M. Rushing resigned.

West Shore, New Jersey Junction & Walkill Valley.—Mr. J. D. Laying, Second Vice-President and General Manager, has issued the following circular under date of May 30, 1898: "G. E. Hustis is hereby appointed General Superintendent of the West Shore, Walkill Valley and New Jersey Junction Railroads, in place of C. W. Bradley, resigned.

West Virginia & Pittsburgh.—Mr. A. H. Kunst has been appointed General Manager, with headquarters at Weston, W. Va.

Western Transit.—Mr. S. D. Caldwell, formerly for thirteen years General Manager of this road, the lake line of the New York Central Railroad, died at his home in Buffalo, N. Y., May 27, at the age of 70 years.

MASTER CAR BUILDER'S ASSOCIATION.

Thirty-second Annual Convention.

Reports of Committees.

SPECIFICATIONS FOR AIR-BRAKE HOSE.

A. M. Waitt, Committee.

If it is considered that there are over 650,000 cars and locomotives in this country at the present time equipped with air brakes, and that the highest guarantee given on the life of air hose by manufacturers is only twenty-four months, and that a large percentage of the air hose are renewed for defects not inherent in the hose before they are twenty-four months old, it will be seen that the railways of this country require probably over 600,000 air-brake hose, costing with present prices almost, if not quite, \$1 each, to supply the requirements for yearly renewals.

There is a general impression that the strength of an air hose to resist bursting is the one great requisite. It is a fact, however, that almost any hose in the market will withstand an initial bursting pressure many times greater than the maximum strain put upon it in ordinary use.

There seems to be a generally accepted opinion, but without any good reason therefor, that it is necessary for an air-brake hose to be made four-ply—that is, composed of four wrappings of heavy cotton canvas—in order to make it of sufficient strength to stand the strains put upon it in service. Tests made, by bursting a large number of hose of various plies and various styles of manufacture, have shown that four-ply air hose are made which will burst at 400 pounds pressure, while other hose made with only two-ply fabric, but manufactured by a different method, cannot be burst at pressures of over 1,200 pounds. In the construction of an air hose, the canvas or cotton fabric can

be considered as the foundation upon which the structure is built. On the fabric alone reliance must be placed for strength to resist the pressures that are put upon it. With an air-brake hose on freight cars, 90 pounds is about the maximum pressure that they are called upon to resist. If hose are specified to stand a bursting test of 500 pounds, a factor of safety of a little over $5\frac{1}{2}$ is thereby required, which seemingly should be amply high for all requirements.

[A description in detail of the manufacture of hose is given by the author. For a similar description see our issue of October, 1897, p. 335.—Editor.]

During the past two years a new style of hose known as the tubular construction has been quite largely introduced. As I shall have more to say of this form of construction later on, and as its method of manufacture is in some respects radically different from the wrapped hose, it will doubtless be interesting to follow the process. In the tubular form of hose it seems to be quite convenient to make them on mandrels of sufficient length to produce two hose at a time. The mandrel is hollow, about five feet long, and of diameter suited to the inside diameter of the hose. A sheet of thin rubber for the tube is cut to proper length for two hose, and of proper width to wrap around the mandrel two or three complete turns. This sheet is laid on a perfectly flat and smooth table, and the mandrel, well soap-stoned, is laid on it and rolled over it two or three times, thus

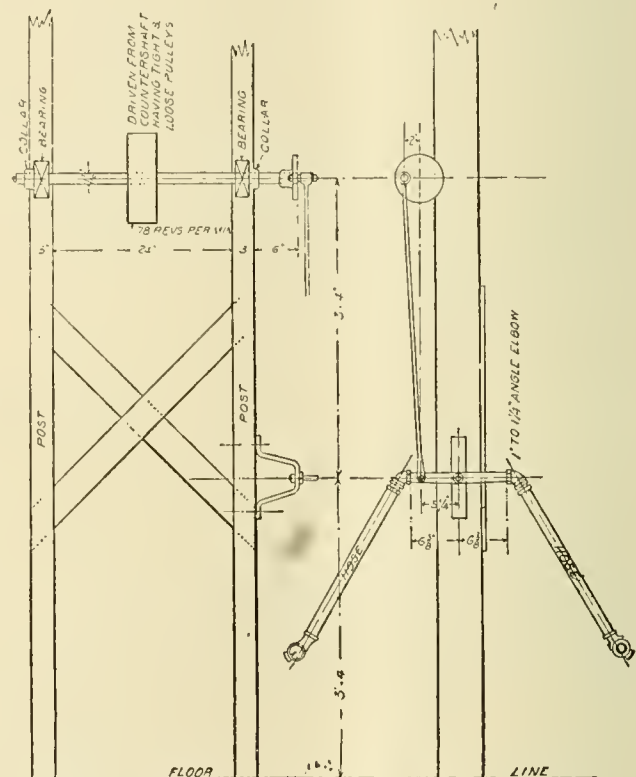

Machine for Testing Hose by Kinking.

forming the tube, the lapping edge afterward being rolled down with concave roller. The mandrel with its tube cover is next placed in position in center of a weaving machine similar to that used in making tubular lamp wicking, and while in this position a cotton covering is woven around it, the mandrel being fed through the machine at same speed that fabric is woven. The tightness of fit of tube and the closeness of weaving is perfectly adjustable, as well as the thickness of the fabric, which can be varied by increasing the number of threads used. After the first layer of fabric is woven, the inclosed mandrel is placed on a rack over a trough filled with rubber cement. The newly woven tube is first given a thorough coating of very thin rubber cement, and after this is sufficiently dry several succeeding coats of greater density are applied, proper time for drying being allowed between the coats. This process completely fills all the pores of the fabric, excludes the air, and cements the fabric together, and to the tube, and also provides an adhesive surface for the friction coat. After the cement coats are applied the mandrel is placed on the table and a friction coat of rubber one thirty-second or sixteenth inch thick is applied in the same manner as the original inner tube, the lapping edges as well as the balance of the covering being carefully rolled down so as to exclude all air. Next, another tube of fabric is woven over the rubber friction coat, and again the texture of the fabric is filled with rubber cement as before, after which the cover is applied in the usual way. The hose are now cut to proper lengths while on the mandrel and a thin

rubber cap piece is applied, and the hose is then ready for the usual wrapping in wet cotton cloth and the subsequent vulcanizing.

The use of inferior materials in hose manufacture, combined with the greatest care in the process of construction or the use of the best material with carelessness in putting it together, is sure to produce hose which will give unsatisfactory service and short life. With the object of ascertaining what steps have been taken by the railroads represented in this Association to insure proper materials and processes of manufacture in the construction of air hose and also with a view of ascertaining what qualities of air hose are being accepted and used by the railroads, a circular of inquiry was sent out to representative members of our Association, asking for copy of specifications under which their hose are purchased, and the qualifications required by tests before acceptance, also a sample of hose purchased was asked for. Very few replies were received—only twenty-two out of the entire number of roads represented. The reason for this may be inferred from the nature of some of the replies, namely, that no attention whatever has been given to the subject by 90 per cent. of our companies. That it should have instant and urgent attention is shown by the results developed in tests of twenty-six sample hose received for test. These were of eight different makes, and undoubtedly of greatly varying prices. They range in quality from first-class down to the grade of common cheap garden hose, made largely of reclaimed rubber. Only four of the manufacturers represented had furnished to the railroads

equipment. From the hose scrap pile we find prominent among the causes of disability among hose:

1. Kinked, with rubber of cover badly cracked at kink, exposing canvas to the weather and causing leakage. In these hose it will often be found by opening up the hose that the rubber in the tube is cracked near the kink, and there is nothing to prevent moisture inside the hose from working into the canvas and following it round and round till it reaches the outside of hose. Where the moisture goes the air can follow, hence from this cause we may have many leaky and burst hose. There is far less danger from the cracking of the cover, as there is no air pressure to help force the moisture inward. Another effect of kinking is to cause a separation between the different layers of the hose, and also to break the fiber of the cotton in the canvas and weaken it at that point.

2. Porous or leaky around the ends of the hose near fittings. An examination of the interior of such hose after the fittings have been carefully removed will show in a large number of cases that the rubber tube has been slightly torn or cut, either wholly or nearly through the canvas, caused by bruising of tube in forcing the fittings on carelessly, or by cutting of tube by roughness of the fittings.

3. Chafed or cut by chafing. This is a quite common cause of hose removal. It comes from being hit or rubbed, generally at the nipple-fitting end, thereby bruising or cutting the cover, sometimes into the first or second ply of canvas.

There are forms of construction of hose in which the canvas and the rubber accommodate themselves with equal facility to the bending, as is shown by the fact that with such hose on the kinking machine there is no perceptible heating at the point of bend, and consequently no tendency to change the normal relation between the fabric and the rubber.

The form of construction last referred to is the tubular. Long-continued tests on the kinking machine have shown that the tubular form of hose will outlast from three to four of the best make of three or four ply wrapped hose, before showing a leak. Experience with such tests has failed to develop over 32,000 revolutions of the machine with four-ply hose before hose would commence to leak at the bend, while with the two-ply tubular hose it required a little over 1,000,000 revolutions to cause a leak.

The objection to excessive expansion, on account of its causing the rubber to crack more quickly, is a reasonable and strong argument for having hose made with enlarged ends. The ordinary 1½-inch hose is seven thirty-seconds inch less in inside diameter than the small end of the Westinghouse fittings, and ⅜ inch less than the enlarged part of the fitting. It surely is not good practice to put rubber into the hose and then require it to be permanently stretched ⅜ inch in diameter in order to force the fittings on, when with a little more work by the manufacturer the hose can have slightly enlarged ends which will take the fittings quite readily, and without stretching and straining the rubber and canvas, and thereby surely shortening its ultimate life. Another reason for enlarged ends is the fact that the air-brake fittings are unfinished malleable castings, which oftentimes have small rough or sharp projections on them, which are very liable to cut or tear the inner tube of the hose.

Quite extensive experiments have indicated to the writer that a simple two-ply hose, properly made with 22-ounce duck, can be made strong enough in its resistance to bursting pressure, but it will not give safeguard enough against results of chafing of cover or tearing of tube. If, however, in addition, the composite cover and tube are used, a hose is obtained, if good materials properly put together are used, that is soft, pliable, and of sufficient strength to resist a bursting pressure of from six to eight hundred pounds.

In concluding this paper, it will be desirable to summarize the deductions from the discussion of the various points, by outlining a short draft of a specification which will at least insure by its use the obtaining of reliable hose, well made, and of a higher grade than the average now manufactured, and which will undoubtedly give longer service than a large percentage of the hose used in the past.

[Recommended Specifications for Air-Brake and Signal Hose.]

1. All air-brake and signal hose must be soft and pliable, not less than two-ply nor more than four-ply.
2. The tube must be hand-made, composed of not less than two calenders of thin rubber; it must be free from holes, or imperfections in joining, and must be so firmly united to the cotton fabric that it cannot be separated readily without breaking or splitting the tube. The tube must be of rubber, of such composition and so cured as to successfully meet the requirements of the stretching test given below. The tube must not be less than three-thirty-seconds inch thick at any point. It may preferably be made in composite form, with a complete inner tube of one-sixteenth inch rubber wrapped with a single wrapping of 8-ounce cotton canvas, the whole being covered with an outer tube of one thirty-second inch thick rubber.
3. The canvas or woven fabric used as wrapping for the hose to be made of good quality cotton, loosely woven, and to weigh not less than 22 ounces per yard, and to be from 38 to 40 inches wide, except when woven with a seamless tubing. The wrapping must be frictioned on both sides, and must have in addition a distinct skimming coat or layer of gum between each ply wrapping not less than one thirty-second inch thick. The friction and coating must be of the same quality of gum as the tube. The canvas wrapping to be cut and applied on the bias.
4. The cover must be of the same quality of gum as the tube, and must not be less than one-sixteenth inch thick. The cover may preferably be made in composite form in the same manner

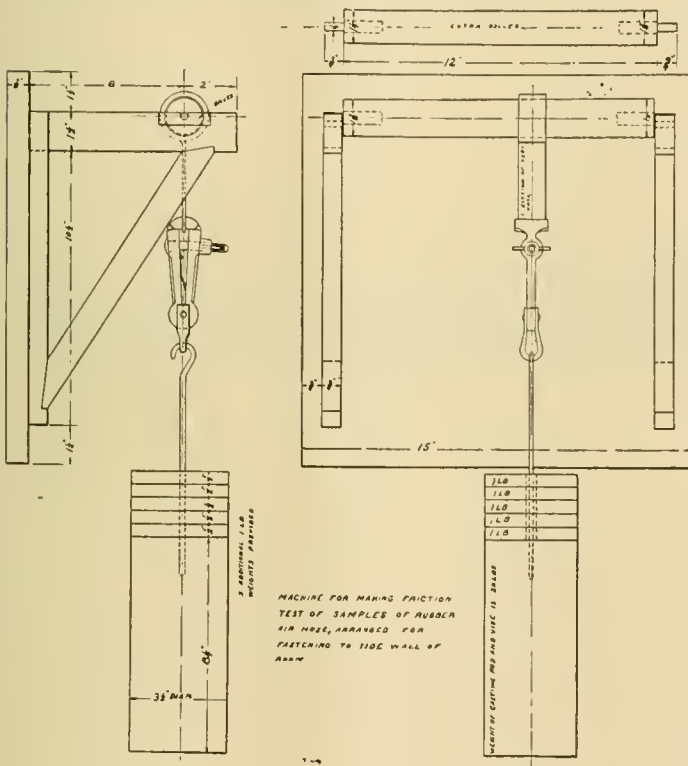

Apparatus for Testing "Friction" of Hose.

hose which, in the matter of good friction and good rubber properly cured, would meet the requirements of the specifications of the Lake Shore, Erie and Baltimore & Ohio railroads.

If the hose successfully resists a pressure of 500 pounds, a section one inch long is cut from some part not near the rupture, and by means of a knife the outer cover is cut through to the first wrapping of duck or woven fabric, and with the aid of a pair of pliers this outer course is separated from the balance for about one inch. A convenient clamp is next attached to the free end and the section is slipped as far as possible onto a slightly tapered wood or metal spindle, which has an outer diameter about the same as inside diameter of hose. This spindle is placed in its position in a friction-testing machine, which is shown in Fig. 1, and a 25-pound weight is suspended from the separated end by means of the clamp. The distance that the hose unwraps in ten minutes determines if the friction meets the requirements.

After the one-inch section is unwrapped to the tube, if made in the best manner, it should be found very difficult to separate the rubber of the inner tube from the canvas wrapping. A little experience, however, aided by a few drops at a time of naphtha, will enable the separation of rubber tube, rubber cover, and even the friction skimming coat, all of which are then tested in the stretching testing machine shown in Fig. 2. If the test hose successfully passes the friction and stretching tests, all of the hose in the shipment are examined to note their compliance with the balance of the requirements.

The scrap pile is always a good and fruitful field for observation as to causes of weakness or removal of defective parts of

as provided for with the tube. In this case there must be not less than one thirty-second inch thickness of rubber between the outer ply of wrapping and the 8-ounce duck forming part of the cover, and there must be an equal thickness of rubber on the outside.

5. Air-brake and signal hose are to be furnished in 22-inch lengths. Variations exceeding $\frac{1}{4}$ inch above or below this length will not be accepted. The inside diameter of all such hose to be not less than $1\frac{1}{4}$ inches in the main part, or exceed 2 3-16 inches, or be less than 2 1-16 inches at the enlarged ends. Hose must be finished smooth and be regular in size throughout, as above indicated; ends of hose to be capped with from 1-16 to $\frac{1}{8}$ inch of rubber. Caps must be vulcanized on, not pasted or cemented.

6. Each standard length of hose must be branded with the name of the manufacturer, year and month when made, and the standard railroad mark, and also have a table of raised letters at least three-sixteenths inch high, to show date of application and removal.

All markings except the road mark may be combined in one plate.

All markings to be full and distinct, and made of a thin layer of white or red rubber vulcanized on, and so applied as to be removable only by cutting with a knife or sharp instrument.

7. Air-brake and signal hose will be subjected to the following tests:

Each hose must stand a proof pressure test of 300 pounds without failure of any kind. With every lot of two hundred or less shipped to one point, the manufacturer must furnish free of charge one additional hose for test. From each such lot one hose will be taken at random, and subjected to the following tests in the order named:

Bursting Test.

The test hose must stand a hydraulic pressure of 5000 pounds before bursting, and must not expand more than $\frac{1}{8}$ inch in diameter under a pressure of 100 pounds.

Friction Test.

A section one inch long will be taken from any part of the hose, and the friction determined by the force and time required to unwind the hose, the force being applied radially. With a weight of 25 pounds suspended from the separated end, the separation must be uniform and regular, and when unwinding the average speed must not exceed 6 inches in 10 minutes.

Stretching Test.

A 1-inch section of the rubber tube or inner lining will be cut at the lap or thickest part. Marks 2 inches apart will be placed on it. The 1-inch strip will next be stretched until the marks are 10 inches apart and then released immediately. The piece will then be remarked as at first and stretched to 10 inches, or 400 per cent., and will remain stretched 10 minutes. It will then be released, and the distance between the marks measured 10 minutes after the release. In no case must the test piece break from defective quality of rubber, or show a permanent set of more than $\frac{1}{4}$ inch between the 2-inch marks.

Small strips taken from the cover and friction will be subject to the same test.

8. If test hose fails to stand the required tests, the lot from which they are taken will be rejected without further examination. If test hose are satisfactory, the entire lot will be examined and those complying with the requirements herein set forth will be accepted.

It would seem reasonable that the developments in the manufacture and use of air hose in the next two years will warrant a further consideration of the subject at that time, and it is not unlikely that the superiority of either the tubular or wrapped form of hose will be so clearly demonstrated as to warrant a much more restricted specification; but if hose in the meantime are brought up to the standard just outlined, a marked upward step will have been taken in this important detail of car construction.

RUST FROM SALT-WATER DRIPPINGS.

S. Higgins, A. M. Waitt—Committee.

The origin of the inquiry as to the damage resulting from salt-water drippings is clearly set forth in some remarks that were made by the chairman of the present committee during the master car builders' convention of 1897.

The fact that the Master Car Builders' Association has thought it necessary to appoint a committee to prepare a report on this subject is sufficient answer to the claims that the salt-water drippings are not harmful. The information received by the committee indicates that more interest is being taken in the subject by the officials in charge of the track and bridges than by those in charge of the rolling stock, which is accounted for by the fact that the track and the bridges are being more damaged by salt-water drippings than the car trucks.

It should be understood that the salt-water drippings come from refrigerator cars loaded with dressed beef. In such cars the mixture used for cooling purposes is composed of ice and salt, the proportion of the salt to the ice varying from 6 to 11 per cent., and one refrigerator car will produce about 200 gallons

of salt water every 24 hours, which on an average will contain $8\frac{1}{2}$ per cent. of salt. The committee started out with the idea of having refrigerator cars fitted with one or more reservoirs, to be attached underneath the car body, into which the salt water drippings could be conveyed, the reservoirs to be large enough so that they would not have to be emptied more than once every twelve hours, at division terminals, where the proper provision could be made for taking care of the salt water. This idea, however, met with so much opposition on the part of the refrigerator car owners that the committee abandoned it, not caring to recommend an arrangement that the refrigerator car owners would be unwilling to adopt.

The committee presents two methods that can be followed without much expense, either one of which will improve the present condition of affairs; and, although a patent has been applied for in the case of Design No. 2, it is the opinion of the

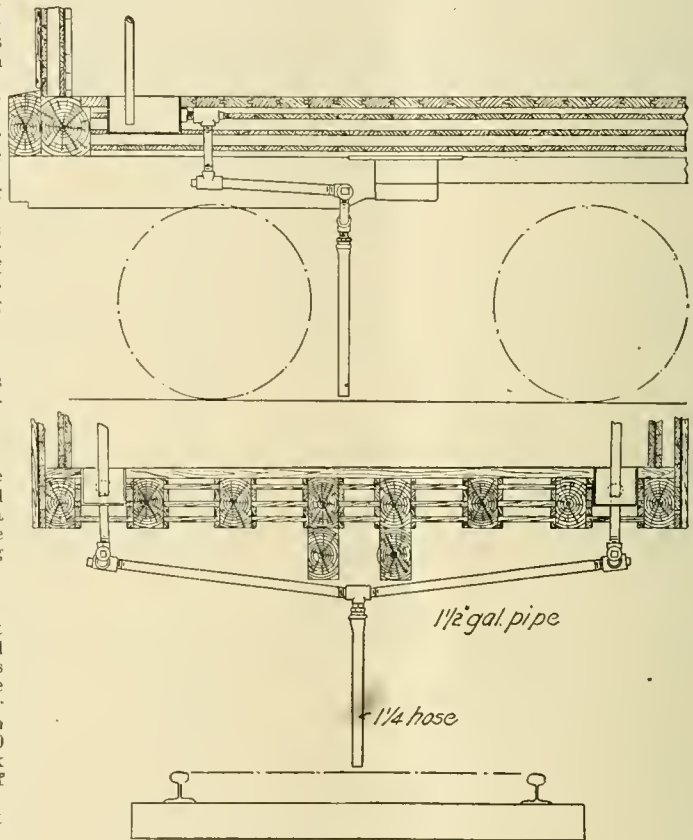

No. 1. Device for disposing of Salt Water drippings.

Dripping Device Indorsed by the Association.

committee that Design No. 2 will give the better results. Design No. 2 will be the more expensive, but will not cost to exceed \$5 per car, including a royalty, if the patent is granted. The principle of both designs is to convey the salt water so that it will drop between the rails, at about the center of the track, where it will do little or no damage.

In fitting up a refrigerator car with either type of attachment, care should be taken to provide caps or plugs at proper points, so that the pipes can be readily cleaned out, and galvanized iron piping should be used, in order to resist the corroding action of the salt water or brine in passing through it.

CONFERENCE WITH AUDITORS.

John S. Lentz, W. W. Atterbury, W. Garstang—Committee.

Your committee appointed to confer with a committee of the American Railway Accounting Officers' Association, with a view of recommending a plan for the simplifying of bills and accounts, met with a committee of that Association at Pittsburg, Pa., on January 27.

After a careful consideration of the subject, the following resolutions were unanimously agreed to:

1st. That all charges against any one railway company or individual car owner, as shown by the representation in the Master Car Builders' Association, must be consolidated into one monthly bill.

2d. That the standard forms for rendering of bills under the Master Car Builders' Rules shall be as follows:

Form "A"—For repairs to cars.

Form "B"—For wheel and axle work.

Form "C"—For summary of bills.

3d. That no bill shall be returned for correction on account of error for less than \$1.00 in aggregate of bill, but said bill shall be passed for payment at once, and the alleged error brought to the attention of the road rendering the same within sixty days from date of bill. The receiving road shall at once issue authority for counter bill to cover the acknowledged error. If the alleged error is not conceded, the matter is to be promptly referred to the Arbitration Committee for decision.

4th. That the Executive Committee of the Master Car Builders' Association instruct the secretary to obtain from each representative member of the Master Car Builders' Association a classification of all cars the road which he represents owns or controls. That this list be printed and distributed in such manner as the Executive Committee may direct.

Your committee does not think it advisable to submit any recommendations in regard to description of passenger equipment cars as between different railroad companies.

Your committee recommends that resolutions Nos. 1, 2 and 3 be incorporated in the M. C. B. Rules of Interchange, and the adoption by the Association of Resolution No. 4.

STEEL CAR FRAMING.

A. E. Mitchell, W. P. Appleyard, Wm. Forsyth—Committee.

The Committee on Steel Car Framing, appointed at your 1897 convention to review plans submitted by members of a similar committee in 1897, and to report upon designs for cars of different classes, has endeavored to collect the necessary information to carry out its instructions, but it has succeeded in obtaining dimensions of only one of the frames submitted in 1897 sufficiently in detail to admit of exact and complete calculations of strength. Your committee has obtained blue prints of steel car frames of several designs which were not described in the report submitted last year, but all but two of these designs lack so many dimensions that calculations of their strength could not be made, and, furthermore, attempts made by the committee to obtain further information were unsuccessful.

But twelve members of the Association replied to the circular which the committee issued to elicit information. The questions contained in the circular will be given later, as well as all answers to them which were received. The members who replied to the circular represent 151,828 cars, or about 12.4 per cent. of the total number of cars represented by the Association. The number of cars represented by those who replied to the circular and by the members of the committee is 208,389, or about 17 per cent. of the number of cars represented by the Association.

The replies received were as follows:

"If you have had any steel car frames in use, please describe all the important facts about them which your experience has brought forth, and furnish working drawings illustrating the same." Six individuals and companies reported the results of their experience with steel cars.

"Which do you consider preferable for the members of the car frames, rolled shapes of standard commercial sizes or special pressed shapes?" Six replied that they preferred rolled shapes; one preferred pressed-steel shapes except for center sills, which he thinks should be "I" beams; and one replied as follows:

"Would prefer pressed shapes for the following reasons:

"a. The various members can be made of uniform strength by placing the metal where it will be most useful.

"b. The parts can be made lighter in weight.

"c. Better connections for the various parts can be provided for."

"Which do you prefer, a car frame made entirely of steel or a composite frame made of steel and wood?" Seven replied that they preferred all steel, two preferred steel and wood, and one preferred steel and malleable iron.

"What parts do you recommend be made of wood?" One recommended that center sills only be made of steel; another replied that the end sill is the only part which it is allowable to make of wood; another recommended that the floor and the superstructure be made of wood in all cars except coal and flat; another recommended that the floor, sides and ends only be made of wood; another advised as follows: "Would recommend that any parts of car subjected to abrasion or which might be injured by the material to be carried or any covering for the purpose of protecting the load from the action of heat or cold be made of wood. Generally speaking, the covering of superstructure and floors, but not of necessity the framing of superstructure."

"What is your opinion of the advisability of using truss rods under side sills of steel car frames? and give the reasons for your opinion." The replies were as follows: Seven recommended that no truss rods be used, one recommended truss rods to support the side sills, and one recommended truss rods if by their use the car can be made lighter.

"Do you recommend that the draft gear of steel car frames be located between centre sills and firmly secured to them, or the use of independent draft timbers below the centre sills, similar to the construction which is now generally used on wooden cars?" Ten replied that the draft gear should be played between centre sills.

"Which do you recommend, wooden or steel side and end sills, and what are your reasons therefor?" Nine replied that they favored the use of steel end sills, and one recommended wooden end sills.

"Please give maximum light weight of car, per ton (net 2,000 pounds), you would recommend for each ton of paying freight?"

600, 700 and 800 pounds are recommended. One member suggested 900 pounds for coal cars only. In another reply 600 pounds is recommended for hopper cars to carry iron ore, and 800 pounds for box cars.

"Recognizing the fact that steel car framing will be used in cars of very large capacities, what type of centre plate would you recommend, and what maximum bearing pressure, per square inch, would you recommend for carrying the car and lading?" Three recommended the use of pressed steel centre plates, and one recommended malleable iron. One member recommended that the bearing pressure shall not exceed 1,600 pounds per square inch, and another 2,500 pounds per square inch. One member thought that cars should not be centre bearing, but that each of the side bearings should support as much of the load as the centre plate.

"What type of side bearing would you recommend for cars of large capacities with steel car framing?" Six recommended plain side bearings of pressed steel or malleable iron, and two recommended roller side bearings.

The members of your committee believe that at the present time it is impossible to design a steel car frame which will meet with universal favor. The extremely limited extent of the experience which has been obtained with steel cars up to date is alone a sufficient reason for recommending the postponement of the selection of a design at the present time.

CARE OF JOURNAL BOXES.

J. T. Chamberlain, J. J. Hennessey, R. H. Johnson—Committee.

Your committee, in summing up the evidence from such data as has been given it in replies to the circular of inquiry, desires to call the attention of the Convention to the fact, that considering the membership the replies were limited, and the committee feels that they are only called upon to take an account of the information given it in the replies.

A large majority recommend high grade oil for car lubrication.

But few use cooling compound, and most all consider it unnecessary in connection with car oil boxes.

That woolen waste is preferred by a substantial majority over cotton waste, and of the former, two are now experimenting with a waste of wool and foreign material, which they claim is superior to woolen.

It is the unanimous opinion that there is no material known that is a practical substitute for waste for journal-box packing, a large majority recommending woolen as the best, and your committee is of the opinion that the above majority represents the views of a majority of the members of this Convention.

The committee calls attention to the fact that two members are making tests, but are not ready at present to recommend and also to the fact that several of the members recommend woolen waste with a percentage of asbestos mixed with it as being better than woolen waste.

That a large majority recommend that waste be soaked between 24 and 48 hours before using, and at a temperature of about 65 degrees, and your committee is of the opinion that waste should be soaked at least 36 hours at a temperature of not less than 70 degrees.

That for all practical purposes the members almost unanimously recommend the common wooden dust guard so generally in use at the present time, and your committee concurs in that recommendation.

That while there is considerable difference of opinion, as indicated in the replies, existing in the minds of the members as to the best oil-box lid, all seem to desire a lid that will keep the oil from getting out of the box and the dust from getting in, the preference expressed being for the so-called Fletcher lid first, with the McCord second.

That the members regard the matter of careful packing as being one of utmost importance, their replies indicating that their careful attention has been given to the subject.

They are careful to have the waste soaked thoroughly at least 24 hours, packed firmly, yet not tightly, care being taken to see that the waste does not come up to the bottom line of brass (within one-half inch), and your committee fully indorses such practice.

That the members very generally consider it good practice to shake out the old and discard the worn-out short waste, mixing the good old waste after re-soaking with the new, the only difference of opinion being as to when and how often it is necessary to do this. The committee is of the opinion that it is good practice, and should be done at least once a year, and the date of repacking stenciled on the truck. It further recommends it should always be done with the removal of oil boxes or change of wheels, and also in shop practice, when there is any indication that the waste has in a degree become matted or partially worn out.

In conclusion, your committee feels that it can do no better than to quote the concluding paragraph of the report of your committee of 1888 on "Journal Lubrication and the Best Practice for Economizing Oil."

"After reviewing the whole subject, your committee is of the opinion that no greater economy can be had in journal lubrication than by the use of petroleum or its products, either with or without mixtures of other oils or lubricants, along with a good elastic or spongy packing of woolen waste or material equally as good, and used in a thoroughly tight and well-constructed journal box, made especially with a view to preventing the loss of lubricant and excluding foreign particles of dust from the journal box."

SPRINGS FOR FREIGHT CAR TRUCKS.

J. S. Lentz, A. G. Steinbrenner, R. P. C. Sanderson, F. W. Brazier—Committee.

The chief aim of the committee has been to submit such designs as are practical and economical, in order that, in case of adoption, they may not become a dead letter, but serve the purpose for which they were designed. Standard springs, to be desirable, must be so designed as to best satisfy the following conditions:

1. The springs must be generally applicable to the majority of the existing cars, without expensive alterations in their application.
2. They must be so designed that they will not increase the cost of maintenance by premature failure or excessive first cost.
3. There should be a minimum number of different coils, and the different coils should be so made as to be readily distinguished one from the other, so as to prevent confusion and mis-

coils and springs, and cause the destruction of the springs, and also a source of expense in the first cost of the spring plates, as the provision for such bolts adds to the cost.

In the designing of the springs themselves, the best practice has been followed in all cases, and spring makers consulted.

Your committee therefore recommends for adoption as standards the following coils, drawings of which are submitted. The combinations in which these coils can be used appear in the schedule.

By reference to the column headed "Arch Bar Trucks," in the schedule submitted, it will be seen that the carrying capacities of the group recommended increase by fairly regular gradations. To enable the recommended standard coils to be most generally and economically useful, such groups can be selected and used as come nearest in capacity to the actual load to be carried, without reference to the marked carrying capacity of the car. Thus a heavy refrigerator car of 50,000 pounds capacity and a flat car of 70,000 pounds capacity may use the same com-

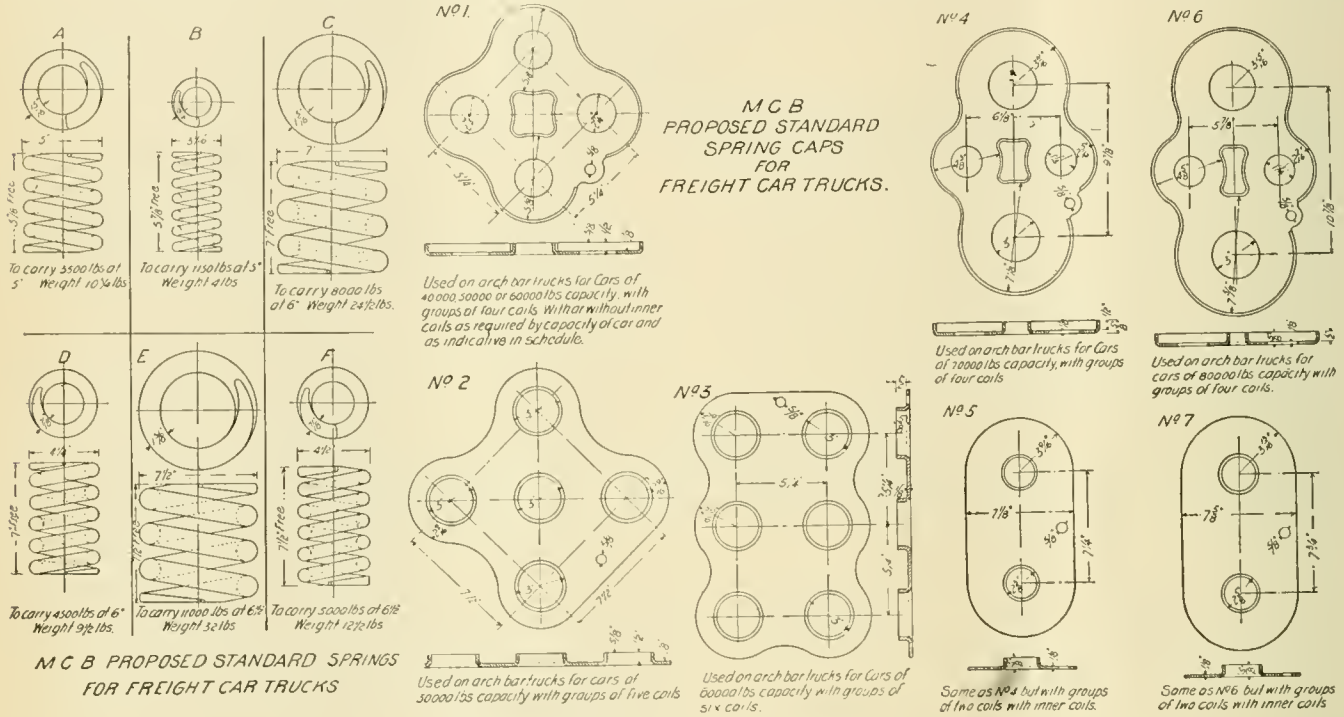

Proposed Standard Freight Truck Springs.

takes in application, and to reduce the cost of stock necessary to be carried for prompt repairs to both foreign and individual cars of usual design.

4. All coils used for outside bars to be wound right-handed, and the inner coils to be wound left-handed, to prevent interlocking.

In the designing of these springs, it has not been considered necessary to consider cars of less capacity than 40,000 pounds, nor does there seem to be occasion to consider a spring for pedestal trucks for cars of less than 50,000 pounds capacity, as such cars are few in number, and are not likely to be perpetual. The fact that there is no M. C. B. standard journal box for 90,000 or 100,000 pounds capacity cars debars the consideration of springs for cars over 80,000 pounds capacity for the present. These can be considered in time to come, when more of these cars are in existence, and some standard journal box is adopted. It was considered desirable that the springs and plates for use with the cars at 40,000 pounds capacity should be available for use under 50,000 and 60,000 pounds capacity cars, so that there will be no loss at such time as the 40,000 pounds cars cease to exist.

Graduated springs, or springs made of other than round bars, have not been considered, and as the elastic limit per square inch is greater for smaller bars than the larger, it is objectionable to use larger sections than are absolutely necessary. Also as spring coils, and not the spring plates, are the expensive articles and those that break, it is not desirable to sacrifice the designs of the springs for the sake of limiting the cost and number of patterns for spring plates, and it is considered preferable to buy the springs by the coil, and the plates separately, not to be put up in sets. Since it has been found upon investigation that the pressed-steel plates are slightly cheaper than malleable iron plates of designs suitable for pressed steel only have been submitted. Moreover, the use of both pressed-steel and malleable iron plates means two separate sets of springs, as, owing to the difference in thickness of the pressed steel and malleable iron (about 1/4 inch for a pair of plates), the springs used with the steel plates would have to be 1/4 inch higher than those used with the malleable iron, to give the same free heights over spring plates. It has further been decided that the use of bolts for securing the top and bottom plates is not only superfluous, but a source of danger, in that these bolts get in between the

combination of springs, on account of the great difference in light weight of the bodies.

If this plan is followed, the committee would recommend that the number and class letter of the coils to be used in each truck should be stenciled on the truck to prevent mistakes being made by repairmen.

To meet the greatest possible variety of conditions drawings for spring caps are submitted, showing caps for springs C and D or E and F, to be used in groups of four, or in groups of two, the smaller coils being placed inside the larger ones. Your committee recommends that the springs and caps submitted, and the schedule for their use, be adopted.

SCHEDULE OF RECOMMENDED STANDARD SPRINGS.

Capacity of car.	Arch-bar trucks—per group.				No. of coils.	Pedestal trucks—per box.			
	No. of coils.	Capacity lbs.	At Inches.	Weight lbs.		No. of coils.	Capacity lbs.	At Inches.	Weight lbs.
40,000 Lbs.	4 of A	14,000	5 1/4	43	No. 1
50,000 Lbs.	4 of A	16,200	5 3/4	51	No. 1	1 of C	8,000	6	24 1/2
	5 of A	17,500	5 3/4	53 3/4	No. 2
60,000 Lbs.	4 of A	18,600	5 3/4	59	No. 1	1 of C	12,500	6 1/2	31
	4 of B	21,000	5 3/4	64 1/2	No. 3	1 of D
70,000 Lbs.	2 of C	25,000	6 1/4	68	No. 4
	2 of D	or No. 5	1 of E	16,000	6 1/2	44 1/2
80,000 Lbs.	2 of E	32,000	6 3/4	89	No. 6
	2 of F	or No. 7	1 of F	17,000	6 3/4	44 1/2

Note.—Heights given in above include spring caps for arch-bar trucks. Number and class letter of springs used to be stenciled on the trucks of cars.

PASSENGER CAR PEDESTAL AND JOURNAL BOX FOR JOURNAL 4 1/4 BY 8 INCHES.

G. W. West, T. P. Purves, Jr., J. W. Marden—Committee.

Your Committee on Passenger Car Pedestal and Journal Box for Journals 4 1/4 by 8 inches, appointed to report to the Convention held in June, 1897, submitted a report at that time,

but certain objections were raised to the inside dimensions of the journal box as recommended. The report was referred to the Committee on Standards of the Association, which submitted the following, through Mr. Soule, chairman of the committee:

"The Committee on Standards, to which was referred the recommendation embodied in the report of the Committee on Passenger Car Pedestal, for axle with journal $4\frac{1}{4}$ by 8 inches, begs leave to report that in its judgment the Committee on Ped-

Truck Pedestal, for axle with journal $4\frac{1}{4}$ by 8 inches, and on journal box for use in trucks (whether passenger or freight) involving the use of the pedestal and axle with journal $4\frac{1}{4}$ by 8 inches."

The committee respectfully reports as follows:

Owing to the wide variation existing between the ordinary Master Car Builders' pedestal now used in passenger equipment trucks and the various pedestals now used in freight

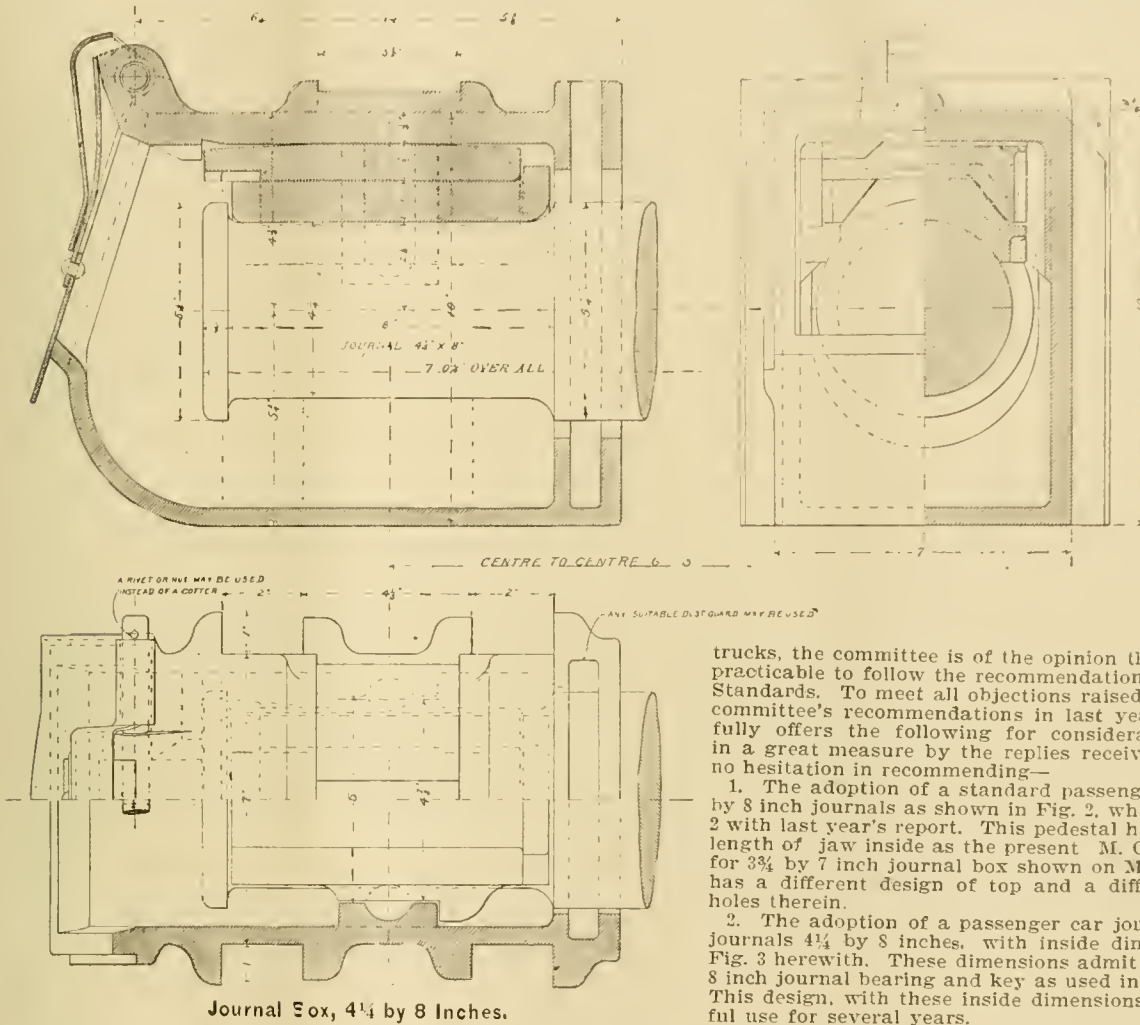

Journal Box, $4\frac{1}{4}$ by 8 Inches.

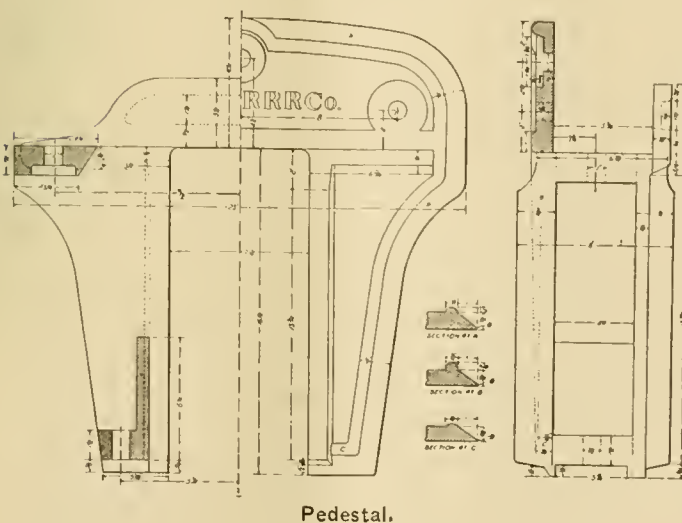

Pedestal.

trucks, the committee is of the opinion that it is absolutely impracticable to follow the recommendations of the Committee on Standards. To meet all objections raised to the wording of the committee's recommendations in last year's report, it respectfully offers the following for consideration; being governed in a great measure by the replies received, the committee has no hesitation in recommending—

1. The adoption of a standard passenger car pedestal for $4\frac{1}{4}$ by 8 inch journals as shown in Fig. 2, which is the same as Fig. 2 with last year's report. This pedestal has the same width and length of jaw inside as the present M. C. B. standard pedestal for $3\frac{3}{4}$ by 7 inch journal box shown on M. C. B. sheet 10, but it has a different design of top and a different location of bolt holes therein.

2. The adoption of a passenger car journal box for use with journals $4\frac{1}{4}$ by 8 inches, with inside dimensions as shown in Fig. 3 herewith. These dimensions admit of the standard $4\frac{1}{4}$ by 8 inch journal bearing and key as used in freight journal boxes. This design, with these inside dimensions, has been in successful use for several years.

THERMAL TESTS FOR CAR WHEELS.

S. P. Bush—Committee.

There were removed during a period of four years and four months on the division of the Pennsylvania Railroad from Pittsburgh to Philadelphia, a total of 7,189 wheels, on account of being either cracked or broken, 6,446 being cracked and 250 being broken. The wheels removed comprised those produced by almost every manufacturer in the United States, and it can be safely stated that practically all cast-iron wheels are subject to cracking or breaking when subjected to service with which they are likely to meet on many of the railroads of the country. A careful examination of these wheels indicated that they were cracked or broken principally by the expansion of the rim, or because of internal strains, coming as a result of imperfect manufacture, so great as to produce rupture when in service.

During the past three years it has been fully demonstrated that cast-iron wheels can be produced which will resist satisfactorily the destructive force of sudden expansion of the rim, and which will not possess, to any material extent, internal strains. This has been demonstrated by actual service, and also by means of a test designed to reproduce, in a measure, the conditions of service, now commonly known as the thermal test.

When first introduced, this test was thought to be unnecessary, and did not represent the conditions of service. The fact, however, that most manufacturers at the present time have no difficulty in producing wheels to comply with this part of the specifications, with but a small increase in cost, would rather indicate that it is quite practicable, even though it does not reproduce exactly the conditions of service. It might be stated on this particular point that the fundamental principle of all specifications relating to material has for its basis the proving of ability not to stand the usual conditions alone, but extraordinary conditions, and this, too, with a good margin to spare, commonly known as the factor of safety.

It is evident that it would not be desirable to obtain that quality in a wheel which would prevent cracking, or fracture,

estals ought to be continued, and to be merged into a committee, which, it is assumed, will be appointed on the recommendation already made by the Committee on Standards, to adopt the present standard journal box for use in trucks (whether passenger or freight) having pedestals; the committee so continued to be designated, however, as the Committee on Passenger

at a somewhat increased cost, but which at the same time would reduce the average life materially. The opinion has been expressed by a few that if wheels are produced so as to withstand the thermal test, the wearing quality, or mileage life, will be very materially reduced. Wheels manufactured to withstand the thermal test have not been in service a sufficient length of time to demonstrate it generally, but it is thought that in another year some well-authenticated facts can be given.

Those making the above assertion endeavor to demonstrate the correctness of their position by presenting figures showing the mileage life of wheels on some roads known to have one of the qualities spoken of above, and those on other roads having the other quality spoken of to a greater extent than the former. To put this difference in quality more specifically, it might be stated that the wheel which is said to produce a greater durability of tread and flange contains a greater proportion of combined carbon, while the wheel that is best adapted to withstand the thermal test has a larger percentage of graphitic carbon.

The author then discusses the methods of stating the life of wheels, and says:

If the average of the total number of wheels in service for five consecutive years be taken, and this sum divided by five, and the yearly average of the wheels drawn for the same five consecutive years be taken, then we obtain the average life in years for the wheels drawn, which applies with considerably greater accuracy to the last one of the five years in question. Again, if we drop the figures for the first year of the group and take the figures for the succeeding year, we obtain another average life of years corresponding to the wheels withdrawn during the last year, and so on.

Of course, the total mileage life of a wheel depends directly on the depth of the chill, as well as upon the quality, but if two wheels, both having the same quality of chill, as well as the same depth, the one being made of iron of high combined carbon, known as hard iron, and the other being made of iron with low combined carbon, or the tough variety, it would certainly be expected that both wheels would give the same mileage life, so far as the chill is concerned, but that the latter would withstand the heating of the rim, or the thermal test, better than the former.

Through the General Superintendent of Motive Power of the Pennsylvania Railroad, Mr. F. D. Casanave, and the chemist of that road, Dr. C. B. Dudley, I am able to present the following facts bearing on this point:

Twenty wheels were selected from those in service, representing some of the principal makes of the country, all of which were subjected to the thermal test, 10 passing it successfully and 10 failing. Chemical analyses were made of the iron of which these 20 wheels were made, two sets of samples being taken, one from the body, or gray iron, and the other from the chill.

The main point in these analyses, to which special attention is called, is the close agreement in the composition of the chills of these different wheels. If we take the average of those that did and those that did not stand the thermal test, we find as follows:

	Total carbon.	Graphitic carbon.	Combined carbon.
Average of wheels which stood thermal test	3.81	0.42	3.39
Average of wheels which did not stand thermal test	3.73	0.42	3.31

It is difficult to see how any other conclusion can be drawn from these figures than that there is no evidence, so far as the chemical composition is concerned, to show that the chills of wheels which stand the thermal test differ in their physical properties, so far, at least, as the physical properties depend on the chemistry of the metal, from the chills of wheels which do not stand the thermal test. Also, it seems fair to conclude that wheels made in different parts of the country and by different manufacturers do not differ very widely, so far as chemical composition of the chills is concerned. It is quite obvious why this should be so, since the chill fixes the chemical composition within very narrow limits. Therefore, to emphasize what has been stated previously, it seems reasonable to conclude that the wear of wheels depends on the chill, and if chills of various wheels are as closely alike as these analyses show them to be, there is really no evidence that the wear of these chills will differ to any appreciable extent.

Referring now to the manner of conducting the thermal test. The method now used may be criticised to some extent, and justly, on the ground that it cannot be applied with absolute uniformity at all times and at all places—that is to say, in pouring the ring of molten metal around the rim of a wheel, it is difficult, if not almost impossible, to have the iron always at exactly the same temperature, so that in some cases the test will be a little more severe, and in others a little less. The test recommended by the committee last year requires that this ring of metal be poured at a temperature as low as possible without producing seams or wrinkles. It is, of course, difficult to say exactly when the iron is at such a temperature, but it is believed that the foreman in charge of most wheel foundries is so experienced as to be able to tell very closely from the appearance when the iron has arrived at this temperature before pouring. The everyday use of the present thermal test has demonstrated its extreme simplicity, and with the one exception of possible variation in the temperature of the molten metal, it seems admirably adapted to the main purpose. As to the magnitude of variation in the temperature of molten metal used for the test, it is believed that undue significance has been attached to this, and that there is a growing feeling that it is so inconsiderable as to give practical uniformity.

AMERICAN RAILWAY MASTER MECHANICS' ASSOCIATION.

Abstracts of Reports—Thirtieth Annual Convention.

BEST FORM OF FASTENING FOR LOCOMOTIVE CYLINDERS.

By R. P. C. Sanderson and T. L. Chapman, of the Committee.

The boilers, cylinders and frames should, under all conditions, be absolutely inflexible and immovable relative to one another, all necessary limberness of the machine, as a whole, must be provided for by the springs and system of equalization.

The strains that the "Cylinder Fastenings" have to resist are:

First: The direct alternating thrust of the steam in the cylinders at the frames up to, say, 38 tons, reversing itself several hundred times a minute and increased to unknown amounts by shocks due to water in the cylinders.

Second: The direct forward and backward surging of the boiler—as the back end of the boiler must be on slides or links to allow for expansion and contraction, the cylinder saddles alone must resist the tendency of the boiler to move lengthwise, due to train and coupling shocks, collisions, etc.

Third: Forward and backward sliding of the two saddles on one another, due to the cranks being at right angles and the impulses in the cylinders not occurring simultaneously.

Fourth: Wrenching strains due to the engine curving, where one side of the engine must be held back by the other, and the adhesion of the wheels on the inner rail constantly broken.

Fifth: The forward thrust on the cylinder and smoke-box bolts, due to the expansion of the boiler and resistance sometimes offered by the back boiler fastenings being defective or jammed.

Sixth: Wrenching of the saddle, due to the back end of the boiler swinging laterally on the frames; this is a very frequent defect with long boilers having heavy fire boxes, and is especially noticeable on engines having poor back boiler fastenings when they are slipping.

The place to remedy the looseness of the cylinder saddle and smoke-box joint is at the back end of the boiler.

The weight of the boiler should be carried on two, or preferably four, long slides up to 12 inches in length and over.

The weight of the boiler should be transmitted directly from the mud ring to the top of the frame, through substantial chafing pieces on the frames, which can be easily renewed if worn; the mud ring being machined where it rests on these.

The weight of the boiler should not be carried by pads on the sides, depending on studs or rivets.

The boiler should be held down firmly to place by four side clamps, which are not depended on to hold the boiler laterally.

In addition to the lateral security afforded by bearing pieces, the boiler should be held to place laterally by strong bracing placed crosswise under the boiler at the front of the fire box, and, where practicable, across the back of the fire box where the material can be disposed of in the best direction to resist lateral movement, and tie both frames together.

Carrying the back end of the boiler on links and pins is bound to lead to trouble sooner or later. The bearing surfaces cannot be large; they will be hot all the time, and as they cannot be successfully lubricated, must be made a loose fit to start with or they seize and wring off. The smoke boxes of our heavy engines have been too often made as if they had no other duty to perform than to hold smoke, and, because they have no steam pressure to retain, are made of flimsy sheet steel, whereas the smoke box is really a part of the foundation of the whole machine. The smoke box should be made of as heavy plate as the boiler itself, and there should be a strong attachment to the boiler by means of a wide 1-inch thick ring, as well as a second ring at the front of the saddle, and bars 8 to 10 inches wide, all closely riveted to the smoke box.

One member very pithily writes: "We find that too many bolts cannot be used in securing the saddles to the smoke boxes;" but it is believed that if the back ends of the boiler are well secured, as recommended previously, fastening the saddles to the smoke boxes with a double row of 1¼ or 1½ inch bolts all around, spaced 4½ inches or not over 5 inches pitch, having the flanges of the saddles strengthened by ribs, will form, with honest workmanship, as secure a fastening as is needed, but not more than is really essential for heavy locomotives. All the bolts holding the saddle to the smoke box should be on the outside of the saddle in the flange, with heads inside and nuts underneath, where they can be seen. Bolts inside the saddle put up from underneath which cannot be made a driving fit, and the nuts for which must be inside the smoke box, are believed to be worth not the trouble of putting in.

Considering next the fastening of the two cylinders together, it must be remembered that the force tending to separate or slide on one another is exerted at the bottom on the plane of the centres of the two cylinders, and not at the top. To resist this to the best advantage, the strength of the fastening should be at the bottom, and not at the top. The economical trouble from loose and cracked cylinders has led to the very common use of cross-frame braces lipped over the frame bars and shrunk on, both front and back of cylinders on both upper and lower frame bars. When such braces or clamps are used, it is necessary that the frames should have a good inside bearing against the cylinder saddles so the clamps will pull the frame against the casting, and not pull against or shear the frame bolts.

Referring to the strains on the cylinders and saddles previously described in the six numbered paragraphs, it will be seen that there are some that must be wholly absorbed by the

strength of the saddle. The plain bottomless box form of saddle with cored steam and exhaust passages looks massive enough, but the metal is disposed in the weakest possible form to resist the strains referred to. Above all, there is need of plenty of metal to act as a horizontal bed plate at or near the plane of the center lines of the cylinders. We find efforts to remedy this lack by numerous clamps shrunk on in front and back of the cylinders to strain them tighter together, but here again the metal is applied at right angles to the direction of the strains. We also find horizontal plates applied front and back of the cylinders, lipped for the frames; in some instances these being bolted to flanges cast on the saddles for the purpose, and, again, others have been driven to the use of long cast-iron bumper deck plates, filling the entire space from the saddle to the front bumpers. All these are remedies for an originally bad design. There seems to be some tradition, that no one has yet broken away from, that the saddles must not be any longer than the cylinders. For instance, for a 14 by 24 inch cylinder the saddle would be about 28 inches long; for a 33 by 24 inch cylinder, the saddle would still be 28 inches long. The length of the saddle is its strength to a large extent.

Is there any reason why the saddle should not be made 6 feet

and both frames and cylinder saddles all cast in one piece, with the two cylinders and the upper part of the saddle made of cast iron and bolted on.

EFFICIENCY OF HIGH STEAM PRESSURE FOR LOCOMOTIVES.

W. F. M. Goss, Wm. Forsyth, Tracy Lyon—Committee.

At the time this committee was appointed, it was expected that the experimental locomotive at Purdue University would serve to give sufficient data to permit the presentation of a report dealing entirely with experimental facts. Unexpected delays have been met, and the problem has proven to be an extensive one. While more than thirty tests have been run, the full significance of the data obtained cannot be known until it is supplemented by information yet to be supplied. For this reason it has been thought best to withhold the experimental data thus far obtained until the investigations shall have developed definite conclusions. Some reference may, however, be made to the tendencies disclosed by the work already accomplished, and a general discussion of the question may be introduced.

The locomotive with which the two Stephensons competed for and won the prize at Rainhill carried a steam pressure of fifty pounds per square inch. This was seventy years ago. Since the time of the Rocket, the pressure on locomotive boilers has been gradually increasing, and to-day practice in America involves the use of pressures which fall between the limits of 140 pounds and 200 pounds. While many locomotives are running under pressures which are near the lower limit, few are now being built which are designed to carry less than 180 pounds and a pressure of 200 pounds has ceased to be uncommon. What lessons are to be derived from the experiences of the past, and to what extent are they to be relied upon to guide the practice of the future? Will the tendencies which have manifested themselves in the past continue to prevail? Are we to look for a gradual increase beyond 200 pounds, or has the maximum limit already been reached? These are the important questions which naturally suggest themselves in connection with the subject which is to be presented by this report.

Power and Efficiency.—The power developed by a locomotive is a measure of the work done by the steam in the cylinders; it is a function of pressure, steam distribution, diameter and travel of piston, and of speed. The efficiency of a locomotive is a measure of the degree of perfection attending the development of power; concisely stated, it is the ratio of the heat equivalent of the work done in the cylinders, to the heat supplied the fire box. The engine is most efficient which, for each pound of coal burned, develops the largest amount of power in the cylinders.

Anything which affects the efficiency either of the boiler or of the engines of a locomotive affects the efficiency of the locomotive as a whole. Boiler efficiency depends upon the proportions of the boiler and the rate of power to which it is worked, while engine efficiency depends upon many factors of which initial pressure is but one. Whatever gain in efficiency is to be derived from the use of higher steam pressure in locomotives is, therefore, to be found in the improved performance of the engine. An ideal engine will always give increased efficiency in return for increase of pressure, but the actual engine may or may not do so.

While the term "efficiency" should not be confused with "power," these terms express facts which, in a locomotive, are closely related. Under normal conditions, a locomotive is worked so near its maximum power that the limit of power is determined by the amount of coal it can burn. If improvement can be had in its process of combustion, or in the more complete absorption of heat by the heating surfaces, or by a reduction in the amount of fuel lost as sparks, the efficiency of the boiler will be increased, and at the limit of power this improvement in performance can be converted into an increase of power. Again, if the cylinders can be made to better utilize the heat supplied them, they may with a given amount of steam be made to yield greater power. It is safe, therefore, in summarizing these statements to say that anything which will operate to improve the efficiency of a locomotive may be employed as a means for increasing its power. If, therefore, increased pressure increases efficiency, it is clear that every interest will be served by its adoption.

Pressure a Single Factor Affecting Efficiency.—There can be no question but that the gradual increase of pressure which has been developing itself for many years past has been accompanied by increasing engine efficiency. It is, however, probably true that much of the improvement which has been observed is the result of betterments in mechanism, as well as of advance in the direction of pressure. This fact makes it desirable to emphasize at this point a matter to which brief reference has already been made, namely, that pressure constitutes but a single factor affecting the performance of an engine. Equally important with pressure are questions of valve proportions and of valve setting, of cylinder clearance, and of degree of expansion. Moreover, the significance of all of these factors is increased as the pressure is increased. Great improvement in efficiency, therefore, should not be expected as the result of attention given to the matter of pressure alone. On the contrary, it should be assumed that each increase of pressure is a demand for greater refinement in the mechanism of the engine. The valve action must be positive and must give a good distribution of steam at short cut-offs; the cylinder clearance must be minimum, the extent of surface bounding the clearance volume must be held to its lowest limits, and as pressures increase, compound cylinders

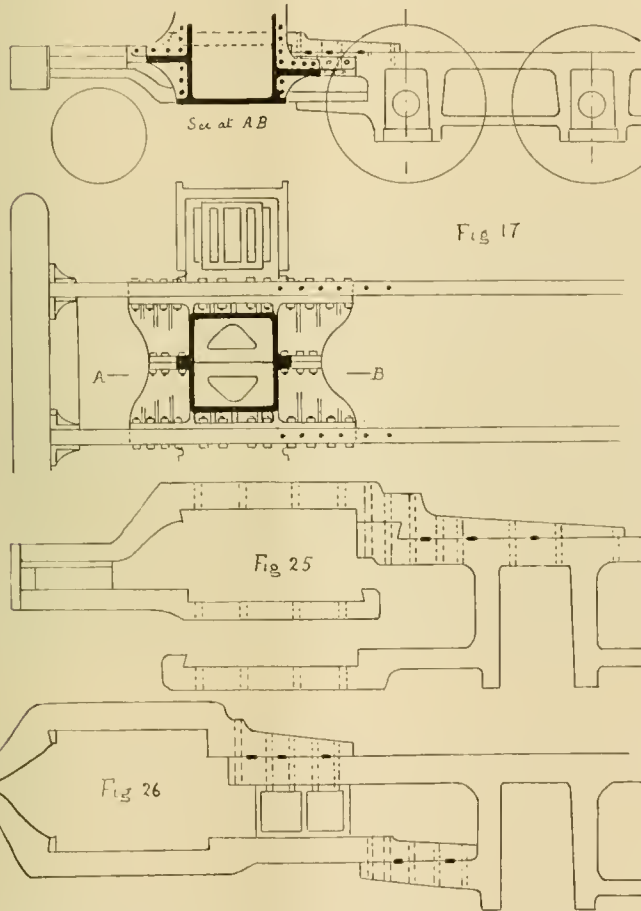

[The reference numbers on these diagrams are the same as given in the report.—Ed.]

long between the frames, and thus furnish horizontal longitudinal stiffness which would keep the cylinders and frames square? This would do away with the necessity for clamps, plates and extra castings. But there are still formidable strains on the saddles that require additional strength in the upper part, and it is certainly good practice to rib the saddle vertically on both sides, front and back, and also use horizontal ribs.

Reverting to the argument previously made in favor of rigidity and against elasticity in the construction of the frames and attachment to the cylinders, it will be admitted that the recommendations of several prominent members to the effect that double-bar frames should be always used for heavy locomotives, even of the eight and ten wheeled types, is in the right direction, and we recommend this as good practice.

A further departure from usual practices is where the bolts holding the cylinder to the frames are put in from the bore of the cylinder. This was due to the large diameter of the cylinders and necessity of keeping the cylinder centres as close together as possible. As long as these bolts do not break or come loose the arrangement is a simple method for overcoming the difficulty; but if the head of one of them should work back and foul the piston it would likely cause a bad breakdown.

Finally, it may be predicted that a few years will see the very general use of cast steel for locomotive frames, and, as the possibilities with this metal are great, it may be that we will

must be used. With such attention to details, it is probable that each increase of pressure will be found to contribute its share to the progress of the future.

There are those who view the situation to-day with the feeling that increase of pressure, being rather easily obtained, has advanced more rapidly than other measures affecting the efficiency of the locomotive. They assert that time must be had in which to perfect other details before further advances in pressure are made. If this position is true, it is likely that as in marine practice an advance in boiler pressures awaits a general adoption of the water-tube boiler, so in locomotive practice a further advance in pressure awaits the more general advent of the compound engine.

It is frequently assumed that the process of gradually increasing pressure beyond limits now common will soon reach a point beyond which it will be found impracticable to go. Difficulties in maintaining a satisfactory condition of lubrication, in using soft metal packing, and in using water glasses under pressures which much exceed 200 pounds are often cited in this connection. It would appear, however, from experience already had in marine work, that none of the difficulties are such as will block the way to the adoption of higher pressures whenever it shall be demonstrated that higher pressures are needed to further increase the efficiency of our locomotives.

High Pressure on Simple Locomotives.—The term "high pressure," as employed in this paragraph, refers to pressures above 160 pounds. The effect of such pressures on the performance of non-compound locomotives is now to be considered. The arguments for and against their adoption may be summarized as follows:

IN FAVOR OF HIGHER PRESSURES.

1. Smaller cylinders, and consequently lighter reciprocating parts.
2. Reduced width of engine outside of cylinders.
3. Reduced first cost of engine.
4. Reduced transportation charge because of reduced weight.
5. A possible gain in the efficiency of the engine, whereby a given power is developed on less steam and on less fuel than could have been done with a lower pressure.

AGAINST HIGHER PRESSURES.

1. Increased weight of boiler.
2. Increased first cost of boiler.
3. Increased transportation charge, due to increased weight of boiler.
4. Probable increase in small heat losses, as from radiation and from leakage past valves and glands.

Reviewing the arguments as summarized above, it is to be noted that the important factor favoring the adoption of higher pressure is the possible economy which is expected to result. The other advantages are incidental, and while some of them may have great weight in particular cases, their significance in the general case merits but slight attention.

The economy which is to result from an increase of pressure must be sufficient to balance all of the considerations which in the foregoing summary appear against the adoption of such pressures. It is evident that unless the gain in efficiency is material, the net result of increasing pressure will be disappointing.

In this connection it will be profitable to review briefly the results of tests run under different pressures on the experimental locomotive of Purdue University. This locomotive carries 250 pounds pressure; its cylinders, having been constructed for special investigation, have an unusually large clearance, and at the time of the tests the valve setting gave excessive lead at very short cut-off. It is significant that these defects were sufficient in their effect to more than neutralize the gain which might otherwise have resulted from the use of higher pressures. It is, in fact, so easy to fail in securing the anticipated gain from increase of pressure, through some minor defect of design or of adjustment, as to make it probable that the most economical pressure for simple engines, in their present stage of development, is within the limits of present practice.

High Steam Pressures for Compound Locomotives.—It has already been argued that compounding is a means to the economical employment of high steam pressures, from which it follows that the maximum pressure for compounds is higher than for simple. Existing data are insufficient to serve as a basis for any prediction as to the effect of successive increments of pressure upon the efficiency of compounds of existing types.

High Pressure and Engine Dimensions.—As is well known, the volume of the cylinders of an engine which is to develop a given power is, other things being equal, inversely proportional to the available pressure. As the steam pressure is increased the size of the cylinders may be reduced. On many roads the width of engines over cylinders is already very close to the clearance width along the right of way. On such roads a demand for engines of greater power cannot be met by increasing the diameter of cylinders; hence, resort must be had either to a longer stroke of piston or to higher steam pressure. Demands of this nature will unquestionably stimulate a tendency to the employment of higher pressures, and the end will justify the means.

Boiler Pressure vs. Boiler Capacity.—It is not the purpose of this report to enter upon a general discussion of conditions affecting locomotive efficiency, but the question of boiler pressure is so closely associated with that of boiler capacity that a brief reference to the latter subject seems desirable.

The preceding discussion discloses the fact that the proposition to improve the economy of a simple locomotive by increas-

ing pressure beyond present limits is of doubtful value. When viewed as one of several expedients which are open for adoption, it is manifestly not of first importance. For example, within limits now common, an increase in boiler capacity offers a way to increased efficiency which is both sure and significant. If, for example, it is desirable to increase the efficiency of a locomotive now carrying 140 pounds of steam, by giving it a new boiler of the same dimension with the old, but designed for a pressure of 200 pounds, the effect produced will be entirely due to increase of pressure. The economy resulting cannot be large, and may, as in the case of experiments already cited, amount to nothing. The new boiler may weigh, approximately, 5,000 pounds more than the old. Now, it can be shown that if, instead of adding to the weight of the locomotive by making a stronger boiler, the same increase of weight had been applied to making a larger boiler, the resulting economy would not fail to be material.

In the five appendices to the report much valuable comment is made, all with a direct bearing on the subject of the report. As to the tendencies to be expected from increasing pressures, Prof. Goss says:

Two important facts are to be noted in this connection. One is that every increase of pressure results in a definite reduction in the amount of heat consumed per unit of power. It is this fact which is fundamental in any argument favoring increase of pressure. The second is that the rate of change diminishes as the scale of pressure is advanced. Thus, increasing the pressure from 25 pounds to 50 pounds reduces the heat consumption of the ideal engine 27 per cent., while an equal increment of pressure from 275 pounds to 300 pounds affects the performance of the ideal engine 2.9 per cent. It is evident from this statement of facts concerning the performance of the perfect engine, that chances for improving engine economy through increase of pressure have been greater in the past than they are likely to be in the future. Assuming the present limit to be 200 pounds, the possibility of improving efficiency through increase of pressures alone are not so great as when the limit was 100 pounds.

He sums up the use of high steam pressures in practice by showing that the general practice in marine engineering provides for a boiler pressure of about 175 pounds, with occasionally examples of higher pressures up to 200 pounds. The latter figure is considered the practical limit for shell boilers of large size. Further increase of pressure depends upon the possibility of obtaining a boiler which shall be suited both to high pressures and to general marine conditions. There is a strong tendency to replace shell boilers by water-tube boilers. Especially is this true in naval work, where weight is an important factor, and in yachts of high speed. Where water-tube boilers are used, they commonly carry a pressure of from 250 to 300 pounds, but for the general conditions of trans-ocean traffic the water-tube boiler, in its present forms, has not yet commanded sufficient confidence to insure it a definite standing in this field. It is significant that while marine engineers are generally alive to the advantages to be derived from high pressures, they have not seen their way clear to utilize pressures which exceed those now common in locomotive service.

In regard to the influence of higher boiler pressures upon the cost of maintenance, Mr. Tracy Lyon, member of the committee, concludes as follows:

It is evident that the available data are too meagre to admit of any positive conclusions, but it seems the more probable that the use of high steam pressures need not be attended by any considerable increase in the cost of repairs.

The results of the elaborate tests conducted by the committee were disappointing, and while they were entirely consistent one with another, they were very unexpected, and the new locomotive now in use upon the testing plant at Purdue University did not show as good results, economically considered, as the former one designed for a pressure of only 140 pounds. This was thought to result from differences in cylinder design, and as the cylinders of the present locomotive (See American Engineer January, 1898, page 7) are fitted with bushings in order to permit of experimenting, with various different cylinder ratios, the clearance was excessive and was nearly 50 per cent. more than in usual practice. The valve setting was also unfavorable to good results with high pressures, and the results constitute a better study in cylinder clearance than in the use of high pressures. A discussion of the relative importance of Pressure vs. Capacity of locomotive boilers is given in the fifth appendix, by Mr. Wm. Forsyth, and it is so well considered, so logical and timely, that we shall print it in full in our next issue.

BEST METHODS OF BOILER AND CYLINDER INSULATION.

J. H. Manning, J. F. Deems, Wm. McIntosh—Committee.

The circular and replies were as follows:

1. Do you use any kind of insulating covers for your boilers, other than wood? To this twenty-eight railroads, representing 10,098 locomotives, replied in the affirmative; five, representing 582 locomotives, replied that they used wood only; one railroad, representing 649 locomotives, stated they used wood covering principally, but were trying a few other kinds to find the relative value.

2. If so, what has been your experience, compared with wood lagging, from an economical standpoint? To this five replied they had no experience, seven did not venture an opinion, account of limited experience, twenty-two replied it was more economical than wood.

3. If you have made any tests, please give committee the results, setting forth the manner of arriving at same? To this all replied they had made no special tests.

4. Give cost per square foot applied, and kind of lagging re-

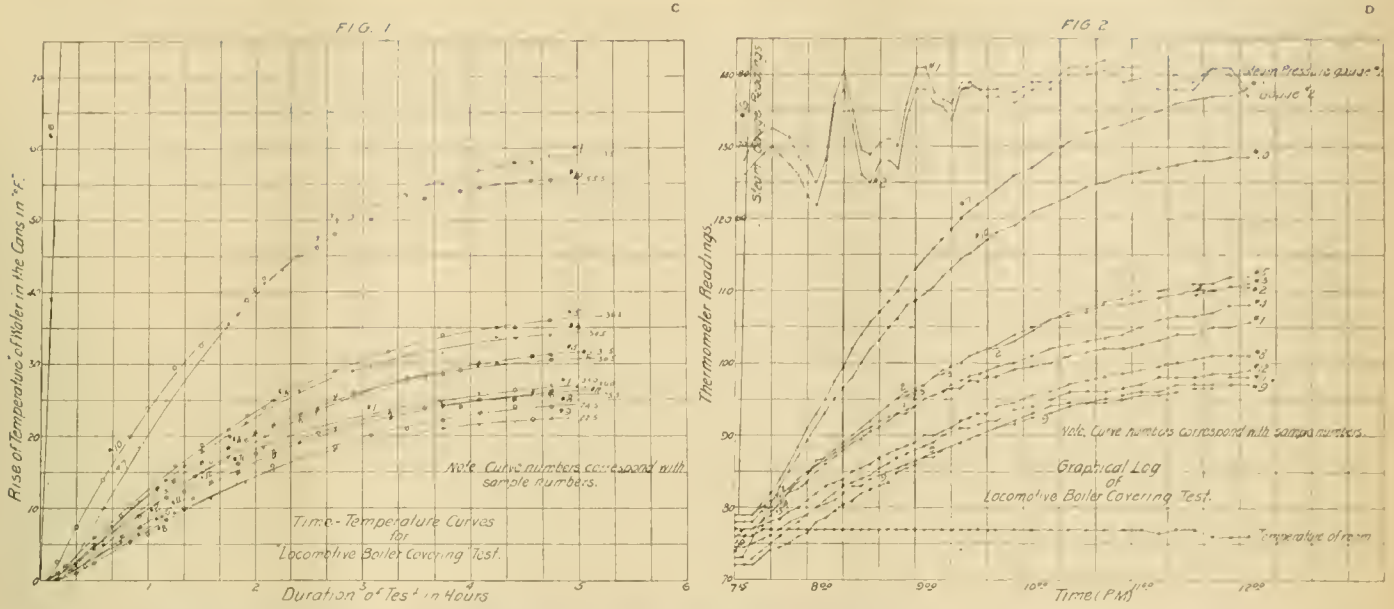

Diagrams Showing Results of Tests.

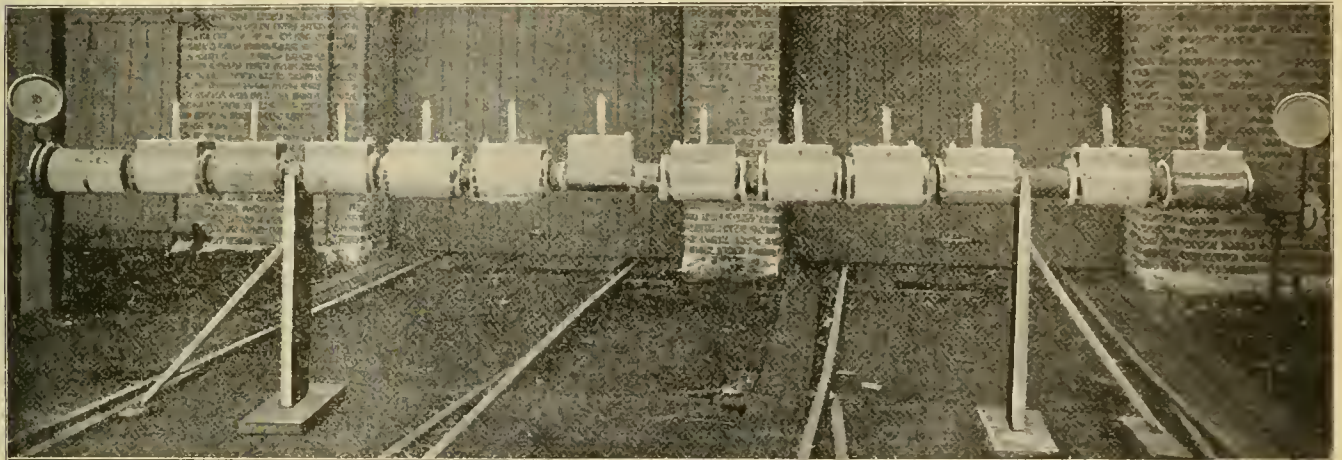

Experimental Apparatus Used in Making Comparison.

ferred to; the latter for information of your committee only? There were twenty replies to this; nine showing lagging costs from 21 to 29 cents per square foot applied, eleven stating that it cost from 7 to 18.6 cents per square foot, according to thickness. Two roads replied that they lagged both sides and heads of boilers; four that they lagged the sides only; three that they lagged the heads of certain engines, with large boiler heads account of excessive heat in the cabs. Nineteen replied that they had no experience whatever in lagging cylinders and steam chests. Of the fifteen that had some experience, six used wood, one filled all spaces around casings and coverings with hair felt, eight used different kinds of insulation.

Samples were furnished by the manufacturers, with the exception of the wood, and in addition to these samples the committee took from store stock additional samples of each kind, which were tested along with those furnished by the manufacturers. The reason for this is obvious.

No. 1. This sample contained:

Asbestos	7.19 per cent.
Lime (calcium oxide)	31.64 "
Sulphur tri-oxide	48.70 "
Loss by ignition	9.60 "

No. 2. Pine wood.

Nos. 3, 4 and 5. These samples contained:

	3 and 5.	4.
Asbestos	68.38;	64.84 per cent.
Oxide of magnesia	16.75;	22.70 "
Loss by ignition	14.90;	13.00 "

No. 6. The bare pipe.

No. 7. This contained:

Asbestos	43.97 per cent.
Lime	51.28 "
Rope	1.83 "
Sawdust	2.92 "

Nos. 8 and 9 contained as follows:

Asbestos	4.0 per cent.
Carbonate of magnesia	95.3 "

No. 10 contained as follows:

Asbestos	46.6 per cent.
Alumina and iron oxides	11.0 "
Magnesia oxide	25.5 "
Loss on ignition	14.3 "

Nos. 11 and 12.

No. 11 contains as follows:

Asbestos and silica	31.60 per cent.
Oxide iron	2.00 "
Oxide aluminum	15.30 "
Oxide calcium (lime)	53.10 "
Oxide magnesia	3.59 "
Sulphur tri-oxide	7.58 "

Samples Nos. 5, 8 and 11, being received in sheet form, were fitted to the pipe; the others were received in cylindrical form to fit a 4-inch pipe. The samples, which were each twelve inches in length, were placed on the pipe with a space of two inches separating them; the ends and joints on each sample were sealed up to avoid the possibility of air circulation in the interior of the samples. On each sample was placed a reservoir made of tin, 5½ by 10 inches in size, with concave bottom to fit the sample, each having an exposed radiating surface of about 136½ square inches and containing 3½ pounds of water. The thermometers used were carefully calibrated and compared. A steam gauge which had been compared with a standard test gauge was placed on each end of the pipe. The thermometers were inserted at the centers of the reservoirs to an equal depth into the water, after which the reservoirs were sealed tight. The reservoir marked No. 6, which was placed on the bare pipe, exposed about 220.7 inches of radiating surface, and contained 7½ pounds of water. For this reason, and the fact that the water in this reservoir boiled so soon after steam was turned into the pipe, the time temperature curve is incorrect; this could, however, be omitted without detracting in any way from the value of the tests.

A steam connection was made at one end of the pipe, and a drain provided at the other, the latter being kept slightly open during the test. Observations began at 7.15 p. m. and were taken every five minutes up to 9.40 p. m., and from that time up to the close of the test every ten minutes, the result of which is clearly shown in Figs. 1 and 2, the former showing clearly the rise in temperature of the water in the reservoirs; the latter the temperature readings every five and ten minutes, as stated. Mr. T. Lyon, Master Mechanic of the Chicago Great Western

Railway, in answer to the committee's inquiry, gives some interesting figures, based on the result of a test conducted by him some time ago, as follows:

"Prepared two lengths of 2-inch iron pipe, each six feet long and connected with a boiler, by covering one of them with wooden lagging and a russia iron jacket, and the other with mineral covering about one inch thick and a similar russia iron jacket. These pipes were placed on an angle so that the water of condensation would drain toward one end, where there was a small cock, and both ends, as well as the steam pipes leading to them, were well covered by being wrapped with hair felt. Steam was turned on and the water of condensation drawn from each pipe and weighed at intervals of one hour, the amount of water being considered as a measure of the relative efficiency of the covering as non-conductors of heat.

"With an average steam pressure of 76 pounds (absolute) in the steam pipe and an average temperature in the room of 56 degrees, the mean loss from the pipe lagged by wood was three pounds of steam per hour, and that from the pipe lagged with mineral, nine-tenths pound per hour, corresponding to a loss of heat of 448 B. T. U. and 139 B. T. U. per lineal foot per hour respectively. This would indicate that the mineral lagging is almost three times as effective as the wooden lagging."

He goes on to state that the loss of heat would be about 0.34 B. T. U. per square foot on radiating surface per degree of difference in temperature of the steam and the outside air, using mineral lagging, and 1.10 B. T. U. using wooden lagging, showing a difference in favor of the former of 0.76 B. T. U., and gives the following example:

"Taking a boiler with 300 square feet of radiating surface, carrying 160 pounds of steam and a mean outside temperature of 50 degrees Fahr., the difference in the loss would amount to 830 pounds of water in ten hours, representing, say, 166 pounds of coal, or, at \$1.50 a ton, 12½ cents' worth. This should represent approximately the saving in coal by the use of a lagging such as tested instead of a wooden lagging under average conditions, and, if these figures are correct, the mineral lagging would about pay for itself in a year. These experiments were made in still air; the conditions in service on a locomotive being still more favorable for further economy."

We found it impossible to collect any reliable data based on actual and practical results, as to fuel economy, as the variables entering into a test of this nature are so great; hence, it was not considered advisable to undertake it.

Your committee is decidedly of the opinion, notwithstanding the absence of this latter information, that economical results will follow the use of good non-conducting material, carefully applied to the boilers, cylinders, steam chests, steam passages and all radiating surfaces where conditions are such that the estimated economy will not be overcome by the inconvenience and expense of removing same for repairs.

THE APPRENTICE BOY.

W. F. Bradley, W. H. Harrison, G. R. Joughins, A. E. Manchester, H. P. Robinson—Committee.

Your committee has drawn up a code of rules, which it believes to be sufficiently broad to be generally acceptable. Your committee also believes that the general adoption even of those elementary rules will be of great benefit, and that they will serve as a foundation on which a complete system, uniform in its details, can ultimately be built. We recommend the adoption of the code of rules as given below, to be known as "The Standard Code of Apprenticeship Rules of the American Railway Master Mechanics' Association." We also recommend the adoption of certain resolutions of instructions which will enable this committee to assist in getting the rules generally adopted.

Apprenticeship Rules.

1. A regular apprentice is one who has had no previous shop experience and is not a graduate of a technical institution.
2. No regular apprentice shall be taken into the shop below the age of fifteen or after the age of nineteen years.
3. No apprentice shall be taken into the shop who has not received the elements of a common education, and who does not give evidence of such capacity as to promise the ability to become a competent mechanic.
4. No apprentice shall be taken into the shop without the consent of his parents or lawful guardians, who shall have a thorough understanding of the conditions of such apprenticeship, and who shall execute such documents, including a release of the company from liability for accidents to the said apprentice, as the company may require.
5. The term during which an apprentice shall serve before receiving a certificate of apprenticeship shall not be less than three years nor more than five years.
6. There shall be a regular apprentice course framed for each shop, which course each apprentice shall go through during his term, the time to be spent on each class of work being defined, and such definition shall be observed as closely as practicable with due regard to the capacities and condition of the individual apprentice.
7. During the term of the apprenticeship a careful and proper record shall be kept of the work in progress of the apprentice, and also of the general behavior and conduct, which record shall be entered on properly authorized blanks or books provided for the purpose not less frequently than once every week during such term.
8. Each apprentice shall be paid for the work done by him upon a scale duly agreed on and provided for in advance.
9. Under no circumstances shall the company assume any

liability for the employment of an apprentice after the conclusion of his term.

10. On the conclusion of the term of apprenticeship, each apprentice shall be given a certificate in a proper form, duly signed by the proper officer of the company, which shall set forth the length of time which each apprentice has served and the work on which he has been engaged, as well as some indication of his general behavior during his term.

11. Apprentices who have already served part of a term in other shops, or who have taken part of a course at a recognized technical institution, may be received under such modifications of the foregoing rules as may be deemed proper.

Under the heading of recommendation the committee suggests four years as the proper length of course, and believes that a boy who does not complete the course in five years had better be something else than a mechanic. The following plan is recommended:

Machine Shop.

Tool Room.—General use of tools, names, etc., work on small planer, drilling machine, shaper and lathes, provide tools; six months to actually serve.

Erecting Shop.—Helping on general work—gang No. 1, one month; helping on general work—gang No. 2, one month; helping on general work—gang No. 3, one month.

Machine Shop.—General instructions, milling machine, boring mill, horizontal machine, axle lathe, and helping in general; three months to actually serve. Boring, driving and truck brasses, and quartering machine; two months. Cylinder boring machine and planer; one month. Rod: Rod gang, three months; small lathe (alone), two months; large slotter, one month; brass lathe, two months; small planer, one month; large and small planers, two months; driving wheel lathe, one month; large lathe (alone), two months; motion work lathe, one month; general vise work, three months; surface table, three months.

Erecting Shop.—General work—gang No. 1, five months; general work—gang No. 2, three months; general work—gang No. 3, four months.

Blacksmith Shop.

1. To start the apprentice on a bolt machine for six months. Here he will learn the rudiments of heating iron; also the setting and adjusting of dies, and at the same time by observation will learn the names of the tools and their use in that portion of the shop. 2. The next six months in operating a steam hammer. In this position he has a good opportunity to note how the blacksmiths handle and form iron; at the same time require him to help at the fires in the immediate vicinity of the hammer. 3. The next six months he should be as a helper on a small fire, with a man who is quick and handy with light work. 4. The next six months on a light fire without a helper, where he will learn to handle the hand hammer. 5. For the next three months give him a light fire with a helper; the fire should be so located that he will be called on to assist in taking heats for the larger fires. 6. For the next six months on heavier work that does not require skill. 7. For the next three months helping at the tool-dressing fire, and if the shop has two tool-dressing fires, the next three months on the second tool-dressing fire. 8. The next twelve months put him on a heavy fire with as much of a variety of work as can be arranged.

Boiler Shop.

1. The first three months heating light rivets. 2. The next three months helping on the heavy sheet-iron work, such as wheel covers, ash pans, etc. 3. Three months holding on rivets for tank work. 4. Three months holding on rivets for boiler work. 5. Six months riveting on patches, chipping and calking on tank work. 6. Six months setting flues. 7. Six months patching and bracing boilers, chipping and calking and general riveting. 8. Six months blacksmithing, to learn how to make and fit braces, to dress necessary tools and assist in fitting up his work. 9. The fourth year to lay out flange and do general boiler work.

Foreman of Apprentices.

It is recommended that some one person be given direct charge of all apprentices and be held responsible for their proper instruction. He can be known as "the Foreman of Apprentices," or he can be designed to perform the duties, without special title, in conjunction with his ordinary work.

The scale of pay must be governed largely by geographical and individual conditions. It is recommended that the rate of pay be 50 cents for a ten-hour day for the first year, with an increase of 25 cents a day for each year thereafter. For an eight-hour day 40 cents a day at the start and 20 cents a day increase yearly.

It is desirable that apprentices should be given the opportunity of acquiring general knowledge of the departments of railways in addition to the work inside the shops. This must be largely a matter for the judgment of the officers of individual companies, but valuable talents may be discovered by giving a boy a chance to get some acquaintance with the drafting room, with signal work, with transportation and operating methods. At the worst, such an acquaintance will not make a mechanic a poorer workman.

It is very desirable that apprentices should receive some instruction of a scholastic nature outside the shops during their term. This, again, is largely a matter of individual judgment, in accordance with the size of the shop and the facilities in the neighborhood for the furnishing of such instruction.

AMERICAN ENGINEER

CAR BUILDER AND RAILROAD JOURNAL.

AUGUST, 1898.

CONTENTS.

ILLUSTRATED ARTICLES:	Page	MISCELLANEOUS ARTICLES:	Page
Locomotives, Atlantic Type in England.....	257	Advantages of Small Grates.....	260
Paint Tests in New York City.....	259	Service Tests of Air Hose.....	260
Locomotive Frame Fastenings.....	260	Timber Tests by the Government.....	261
Carbon Contents of Piston Rods.....	262	Inaccurate Wheel Records.....	261
Electric Mine Locomotives.....	263	Experience with Metric System.....	264
Diesel Heat Engine.....	265	Education of the Apprentice Boy.....	266
Sellers Feed Water Strainer.....	267	Car Lighting from the Axle.....	268
High Steam Pressure vs. Capacity of Locomotives.....	271	Painting Cars by Compressed Air.....	268
Cushioned and Reversible Brake Beam Strut.....	295	Lumber Specifications for Cars.....	268
The Johnson Hopper Door.....	276	Large Locomotive Boilers.....	269
Gunn's Running Board Brackets.....	277	Body Bolsters and Side Bearings.....	269
A Water Purifying Plant.....	283	Engineering Notes.....	273
MISCELLANEOUS ARTICLES:		Firerooms in the Tropics.....	276
Proposed Consolidation of M. C. B. and M. M. Associations.....	255	Tonnage Rating for Locomotives.....	277
How to Know What Others are Doing.....	256	Books and Pamphlets.....	279
Stronger M. C. B. Couplers.....	256	Frog and Guard Rail Protection.....	285
Standard Trucks.....	257	Permanent Exposition in New York.....	285
Lignite for Locomotives.....	258	EDITORIALS:	
		Stenelling Light Weights of Cars.....	272
		Comparisons of Paints.....	272
		Government Timber Tests.....	272
		The Navy at Santiago.....	272

PROPOSED CONSOLIDATION OF THE MASTER CAR BUILDERS' AND MASTER MECHANICS' ASSOCIATIONS.

The suggestion of consolidation by concentrating the sessions of the conventions of the Master Car Builders and the Master Mechanics' Associations in such a way as to permit of holding them both in a single week was made in the address of President Soule to the Master Mechanics' Association last year, the support for this being the possible saving of time. The subject was brought to an advanced stage this year by President Leeds in his address before the same association, and he stated the arguments in favor of the actual consolidation of the associations so clearly that we quote from his remarks. Next to the question of representation this is the most important that has ever been brought up for discussion before the associations.

"The consideration of this matter has firmly established in my mind the opinion that if there ever existed a need for two associations that necessity has passed. The members of either being eligible for membership in the other, and their duties of research and advancement being not only identical but to a very great extent carried on by the members of both associations, the two associations should be consolidated for the mutual advantage of not only the members but of the railroads. Of the members of this association who do not appear in the M. C. B. membership, a very large majority are master mechanics who have an interest in and control car departments, as well as motive power, yet they are represented by one member for the whole railroad system by which they are employed. * * * If the two associations were combined, the work could be done with much less loss of time. For instance, two days are given to the opening. The election of officers and other incidental work consumes about all of two days. All this could and would be condensed into one day for each, and thus save two days; and if our work was largely done by committees, as in my opinion it should be, one week would suffice for the actual attendance. Besides this, in my opinion, a great deal better results could be obtained by one organization as strong as this would be than can possibly be by the two."

This recommendation by the President resulted in the appointment of a special committee to consider and report, to the Master Mechanics' Association, a plan for action, which was adopted unanimously. The part of the report which concerns consolidation was as follows:

"We believe the suggestions as to a consolidation of the two associations under one organization are wise and timely made, and should be carried into effect at the earliest practicable period.

"A large percentage of the car mileage representation in the Car Builders' Association is controlled by superintendents of

motive power or master mechanics who are members of the Master Mechanics' Association, in which all master car builders are eligible to membership, and there would, therefore, seem to be no good reason why all business pertaining to construction and repairs of rolling stock, whether of engines or cars, should not be transacted in one association and at one convention. Fully one-half of the time of members from duty would be saved, and an equal amount of expenses to the railroad.

"The successful merging of the two associations would then render it quite possible under proper restrictions to carry out the suggestions of the President looking to the establishing of an interchange of motive power equipment in certain localities, as well as making it advisable to appoint a standing committee for conducting tests, and indicating to members the necessary requirements for interchange of motive power.

"Your committee recommend and believe that railroad managers will insist that supervision of rolling stock now exercised by the associations shall be placed under one organization.

"Your committee would, therefore, recommend that the Executive Committee of this association be intrusted to at once confer with the Executive Committee of the Master Car Builders' Association and endeavor to arrange for a consolidation of the two associations under such name and conditions of membership as will do full justice to both * * * and the President of this association is authorized and directed to appoint a special committee, who shall also be members of the Master Car Builders' Association, to attend the next annual meeting of the Master Car Builders and present this subject for consideration."

It is perfectly natural that men who have had the interests of one or the other of these organizations close at heart for years should hesitate before taking, and also afterward should regret, action which would mean loss of identity, but when the best interests of the railroads are consulted, and this touches the foundations of both associations, the reasons for consolidation seem to outweigh those which may be raised against it. Whatever individual opinions may be, the union is probably only a question of time. It is interesting to note the observations of the railroad papers on this subject:

"Railroad Car Journal"—"This movement, which has long been in contemplation, now assumes tangible form."

"Railway Master Mechanic"—"It is evident that the consolidation of the two associations is near—probably not more than two years ahead. The tendency this way has been strong for years and lately it has grown in strength. Last year it almost took definite shape. This year President Leeds' outspoken address gave it a start from which there will be no receding. The committee's report on Mr. Leeds' suggestions pushed it a step farther, and the election of a very prominent master car builder to a vice-presidency of the Master Mechanics' Association (a gracious act, the spirit of which the Master Car Builders' Association should have forestalled by electing a motive power man to its presidency instead of holding to its traditions) will have a tendency to make assurance of consolidation doubly sure.

"Railway Age"—"It has been unavoidable that there should be much discussion as to whether it was not a waste of energy to keep two separate associations going, with so much the same work, so largely the same membership and so many topics and interests in common. Year by year this discussion has increased and year by year the conviction has grown among the majority of members that one association, covering the whole field, could better and more economically perform the work now done by the two. Until this summer, however, the subject has, by common consent, been kept in the background, officially ignored and never appearing on the floor of either convention. At Saratoga last week a departure was made, and in the Master Mechanics' convention the question of consolidation was formally brought to the front, firstly, by some remarks made by the president of the association in his annual address, and, secondly, by a committee which was appointed to make recommendations on the subject matter of that address to the association. There is no question that the recommendations of the committee have the approval of the majority of the members of the Master Mechanics' Association. Whether the majority of the Master Car Builders also approve is more doubtful. That many of them do so is certain, and it is equally well known that others do not. But the sentiment in favor of consolidation is growing, and we imagine that the sympathy of managing officers generally will be entirely with it. There may be a year or two of delay yet, but the end cannot be far distant when 'The American Railway Mechanical Association' will take the place of the two existing organizations."

"Railroad Gazette"—"The movement to consolidate the two associations is not new, but it has long been going on quietly, and we judge that the result is inevitable. Some time the associations will be consolidated under perhaps an entirely new

name. Naturally, it will still take two or three years to bring this result about.

"One has only to look over the lists of railroad officers and to reflect upon the changes in their duties which he can remember to realize the development that is going on. The line between the superintendent of motive power and the master car builder has already pretty nearly disappeared on the great roads and largely disappeared on all roads. Or, let one look over the list of active and representative members of the Master Car Builders' Association; he will discover that the superintendents of motive power, master mechanics, mechanical engineers and others bearing titles which indicate that they perform general mechanical duties outnumber by about 70 per cent those whose titles indicate that their duties are confined merely to the car department. In fact, the business of designing, building and keeping up the car equipment has come to be a part of the one great department of railroad mechanical engineering. The irresistible movement is toward organizing this great department under one head. The men who build and repair cars are superintendents or foremen of shops or division master car builders; just as the men who build and repair locomotives are division master mechanics and foremen or superintendents of locomotive shops, and all are part of one mechanical organization. We estimate that this organization is as logical as it is inevitable.

"From this development it has followed that the membership in the two associations has come to be so largely the same that their work is in some degree duplicated. From this it must follow further that the artificial division into two societies of one body of men with one set of duties cannot last indefinitely.

"It has often been suggested in the last few years that if the two associations are not consolidated a third society will be formed. This society would naturally take the men who, by their rank or by their intelligence and activity are actually creating and developing the whole body of mechanical practice on the railroads—the men who have evolved and secured the use of the standards and who are working to advance the art—these are the men whose time and work is most valuable and who are most desirous of avoiding the waste which the present duplicate organization involves.

"There are many reasons why the establishment of a third society would be unfortunate, but we need not go into these now. A consolidation of the two existing associations would avert it for a long time."

HOW TO KNOW WHAT OTHERS ARE DOING.

A short time ago we learned of a plan followed by a prominent manufacturer, who had little time for reading, whereby his company obtained the benefit of all the new ideas brought out in the technical papers in the line of work in which the company was engaged. The papers were opened by a clerk and placed on the manufacturer's desk. He looked them over, and by means of paper slips indicated articles for examination by various heads of departments. These officers read the articles and briefly reported in writing upon their value as bearing on the work of the establishment, returning the papers for permanent file.

The results were seen in the form of improved methods, and it was possible for the concern to profit by the experience of others, in many cases the adoption of the ideas being materially improved upon before being used. The plan is an excellent one, and is worthy of imitation, especially in cases where the visiting of other shops is impossible or undesirable.

One of our most important railroads has its shop foremen spend a specified number of days each year in visiting the works of other roads as well as those of some of the large manufacturing establishments, with a view of obtaining the benefit of all of the latest improvements in use by other progressive people. This practice results in a great saving to the road and costs little, compared with the value of the new ideas obtained.

Speaking of improving shop organization at a meeting of the Western Railway Club, Mr. A. M. Waitt said: "I believe today the shops of our country could be greatly improved if we could arrange for enough time to let the foreman in the blacksmith shop, or the foreman in the machine shop, and others, go and spend a day or so at other shops; let the railroad pay his expenses and let him pick up what he can, and I do not believe there is a shop so poor in this country from which we could not learn something that is an improvement on our practice. I believe if railroad managers would encourage that practice in their higher officers, and have them go out and see what their neighbors are doing and then after getting home

talk it over and try to get better results, a great deal could be done in improving the efficiency of our railroad organization.

"A road may be made up of a consolidation of a number of small roads that have been brought up on different principles of working. If the foreman can be sent to one shop to spend a day there and after a month go to another shop and spend a day there, talking and interchanging ideas with men in that shop, I believe that a great deal can be done in improving shop organization."

In the same discussion, in speaking of conferences among the men, Mr. F. W. Brazier, of the Illinois Central R. R., said: "We have a weekly meeting of all our foremen. We even call in the foreman of our laboring gang who cleans up the yards, and through the foremen we take up each engine and passenger car in the shop. We generally have 25 engines and 60 passenger cars. We will ask, 'What is this engine waiting for?' and if it is for boiler flues we ask the boiler maker what is the trouble with the flues, and if he answers that the storekeeper has not furnished them we will take it up with the storekeeper, who is present, and must explain when we may expect them. It is a regular school, and we find it is the best way to have our men meet each week and exchange thoughts and talk over the orders. Some foremen think: 'We do not care about the other fellow; we have got our work to do and we will do it.' Our weekly meetings draw out the department that is behind. Our foreman of tenders and passenger trucks and our foreman of freight trucks are all called in and each tells what he is lacking through the week. If it is bolts, we ask the blacksmith why he doesn't furnish them. If it is forgings, we ask the storekeeper if he has the right size iron, and in that way we usually keep each department posted and get the best results.

STRONGER M. C. B. COUPLERS FOR HEAVY CARS.

The use of cars of 100,000 lbs. capacity has brought to attention a number of important questions relating to the strength of various parts of car equipment, and particularly to draft gear and couplers. Mr. J. E. Simons stated at the recent M. C. B. convention that with trains weighing 2,100 tons, the pull on the draft gear on a 22-ft. grade was 9,000 lbs. above the capacity of the draft gear employed, although its capacity was sufficient for ordinary conditions. It is evident that draft gear designs need revising for these heavy pulls. The recent improvements in the Westinghouse Friction Draft Gear are interesting in this connection. Couplers also show weakness under the severe conditions, and the following quotations from a communication to "The Railway Master Mechanic" by Mr. A. M. Waitt is pertinent and suggestive:

"The present tendency seems to be undoubtedly in the direction of greatly increased capacity of cars; as a result of this, cars in motion will have much greater momentum, and all the parts of the equipment will be subject to greater strain. The present M. C. B. couplers were undoubtedly designed for cars of lighter capacity than many now in service. Unfortunately they were designed on such lines as to prevent their being properly strengthened within the same limiting dimensions. It is an open question whether the present M. C. B. lines are ideal in the way of producing a thoroughly satisfactory automatic coupler. I do not see any use in trying to strengthen one part of the present coupler, for instance the shank, and leave the head and knuckle the same as they are at present, for the coupler as at present made divides the breakage up between the knuckle, coupler head and shank in quite even proportions. If any general strengthening of the couplers is to be accomplished, it will in the end necessitate heavier knuckles, therefore a head which will not couple with the present heads. If such a change is sought for, it seems to me it would be better for an able committee of experts, from both the manufacturers and the railway men, to see if a design of coupler can be worked out, not necessarily on the present lines, but which will be large enough and strong enough for cars of double the present generally adopted capacity of 60,000 lbs., and in connection with it design a simple connecting piece that will enable one of the suggested new design of couplers to be properly connected with the present M. C. B. type. It is too late a day, in my opinion, to attempt to patch up and make strong and satisfactory the present M. C. B. coupler, which is far from ideal, although it is a vast improvement and source of economy as compared with the link and pin coupler."

NEW LOCOMOTIVES, GREAT NORTHERN RAILWAY OF ENGLAND—ATLANTIC TYPE.

The accompanying engravings show the general appearance of a new Atlantic type engine recently built from designs by Mr. H. A. Ivatt, Locomotive Superintendent of the Great Northern Railway of England. The diagram shows the chief dimensions of the engine and wheels, and the accompanying list presents some information not shown in the drawing. The tender is carried on six wheels in pedestals and holds 3,650 gallons of water and 5 tons of coal. The heating surface and

STANDARD TRUCKS.*

By E. D. Bronner.

Judging from past experience, I should say that we cannot agree on a standard, and even if we were to adopt a recommended practice it would not be largely followed. A standard adopted and fully recognized would impede progress. It would amount to very little in the end, as the practical results sought could be largely accomplished by the adoption of standard parts. To determine what the parts are that fail largely, I

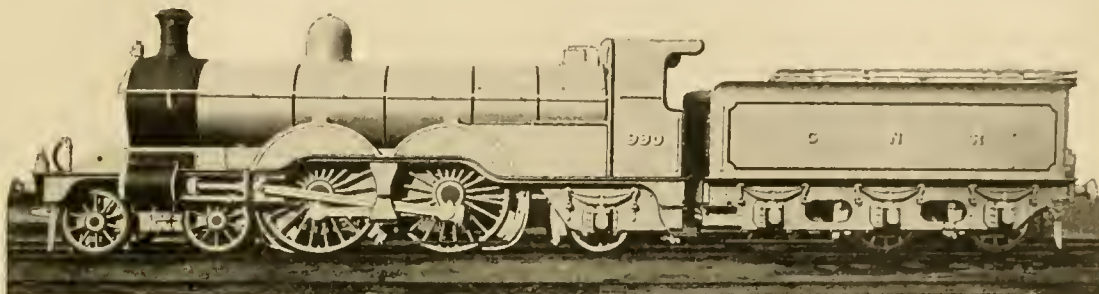

"Atlantic Type" Locomotive, Great Northern Railway, England.

grate area are small for this type and yet the weight is enough for an engine with much greater boiler power. The greatest interest in the design is due to the selection of this type for service in England. There is reason to believe that some of the difficulties recently referred to in discussions of the speed and power of English engines may be overcome by further work in this direction, and we expect to see more designs of this type. This engine has an extension front formed by setting the front tube sheet back into the barrel of the boiler. Macallan's variable blast pipe is used, giving a variation of from 5 to 5½ inches in diameter. The cylinders are 19x24 inches; the total weight of the engine is 129,930 pounds, that

have analyzed the truck repairs on our road for one month. These are the running repairs made at outside repair stations and do not include heavy repair at the shops. The total number of cars receiving repairs of any kind was 9,864. The truck repairs were divided as follows:

Wheels and axle (including journal bearings in a majority of cases)	825
Journal bearings only	988
Journal bearings, wedge	57
Journal box bolts (about 72 per cent. alone)	317
Truck column bolts	173
Truck column guide bolts	163
Arch bars	86
Tie bars	4
Swing hanger pivot casting bolts	2
Bolts in Fox truck (jaw)	2

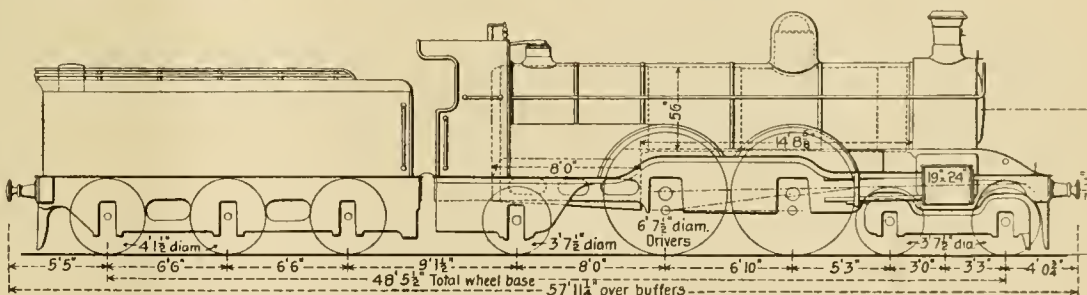

"Atlantic Type" Locomotive, Great Northern Railway, England.

of the tender when loaded being 91,616 pounds. The following further particulars are interesting:

Weight on drivers	69,440 lbs.
" " front truck wheels	33,600 lbs.
" " trailing wheels	26,880 lbs.
" " total	129,920 lbs.
Wheel base, total, of engine	26 ft. 4 in.
" " driving	6 ft. 10 in.
" " total (engine and tender)	48 ft. 5½ in.
Length over all (engine and tender)	57 ft. 11¼ in.
Height, center of boiler above rails	7 ft. 11 in.
Heating surface, firebox	140 sq. ft.
" " tubes	1,302 sq. ft.
" " total	1,442 sq. ft.
Grate area	26.79 sq. ft.
Steam pressure	175 lbs.
Drivers, diameter	79½ in.
Truck wheels, diameter	43½ in.
Cylinders, diameter	19 in.
Piston, stroke	24 in.
Main rod, length center to center	10 ft.
Tubes, number	191
" " outside diameter	2 in.
" " length over sheets	13 ft.

Government tests of the Sims dynamite gun are being made at Mattinecock Point, Long Island, compressed air being used to throw the dynamite projectile. It is said that a range of five miles has been covered, but the detailed records of the tests have not yet been given out.

Swing hanger	31
Swing hanger pivot	17
Center pins	273
Truck truss rods	42
Journal box	39
Journal box covers	14
Truck column	27
Bolster guide block	20
Swing hanger pivot casting	25
Swing hanger casting	4
Spring plank casting	8
Truck bolster chafing plate	3
Truck bolster	34
Truck transom	15
Spring plank	25
Truck springs	40
Nuts without number	

Total 3,234

It will be seen that a large percentage of the repairs is on account of wheels and axles, journal bearings, journal boxes and covers, journal bearing wedges and journal box bolts. These we have standardized for several classes of trucks, and if they were adopted and used by all our members it would obviate much of the difficulty in making truck repairs. On the whole, I shall say, let us give up "rainbow chasing" and save

* "Merits of Diamond and Steel Plate Types." Discussion before M. C. B. Convention, June, 1898.

the time and labor spent in trying to adopt standard trucks. If we can get standard wheels and axles, journal bearings and wedges, journal boxes (which determine their bolts) and possibly standard cross sections for arch bars and diameter of column bolts for 60,000, 80,000 and 100,000-pound trucks, we will get all we can ever hope to compromise on in the present stage of the car builder's art, and practically all that will be necessary.

A great many designs for metal freight car trucks have been brought out, but my experience has been limited to two general classes—the type represented by the Fox, Cloud, Schoen and Hewitt trucks and the variations of the old diamond type of truck brought about by the introduction of metal trucks. The relative efficiency of those of the first type as compared with each other would be a difficult matter to determine, and, not having any data upon which to base a conclusion, I will leave the point for discussion by others.

With both kinds of trucks the function performed is to sustain the weight on the center and distribute it to the journal boxes. The trucks must do this over good surface and bad surface, over curves and tangents, at low speed and at high speed. To do this efficiently the truck must retain its shape in all respects under the shocks and strains it is subjected to. It must remain square to keep the flange wear of the wheels and the train resistance at a minimum. The cross girders or holsters must show little deflection so that too much weight will not be thrown on to the side bearings, and thus increase the resistance to curvature. The transverse strength of the cross girders, transoms or bolsters must be sufficient to resist the shocks of sudden applications of the brakes and buffing. The wheel shock must be cushioned in a manner to produce the least detrimental effect on the structure of the truck or body and also the track. It should be of such design, construction and material that failure of parts will be reduced to a minimum. Failure in detail increases cost of maintenance and decreases safety. It should not have too many vital parts which might, by the failure of any one, wreck the truck, the car or the train.

We must also consider the facility and ease of inspection and repairs or replacements of parts subject to wear. The modern diamond frame truck, either rigid or swing motion, constructed entirely of metal, more nearly meets these requirements than its predecessor constructed largely of wood and with gray iron castings. The metal bolsters and channels are more rigid and less liable to sagging, decay and failure. The introduction of malleable iron parts has also resulted in a decrease of failure of those parts. But let us examine the repair records and see what are the weaknesses of the diamond truck, and whether these improvements would eliminate them. We find that the various wrought iron parts and bolts still remain; that the truck still depends upon too many vital parts; that it is still subject to failure in detail.

It might be said that the larger and heavier parts in the modern trucks will resist more effectually the shock and strains that they are subject to. In this conclusion I think that we would be largely in error, as there have been many well-designed trucks under our older and smaller capacity cars, which were fully as good for their class, barring the metal bolster, as the trucks under our large capacity cars. The latter are merely an enlargement to meet the greater carrying capacity of the cars and still embody all the vital parts and probably most of their weaknesses. These parts are failing as in the past, and these failures will increase as the cars get older and the carrying capacity greater.

The diamond frame type of truck was a better type for small capacity cars than it will be for 60,000, 80,000 or 100,000-pound capacity cars. The frame is still subjected to all the wheel shock uncushioned and the strains induced by trying to force four wheels held in a rigid frame into contact with rail surfaces not lying in a plane. With our 60,000 and 80,000-pound trucks, we retain the same wheel base as in our lighter trucks,

but enlarge and stiffen the parts to carry the increased load, thus robbing them of a certain amount of elasticity which the lighter trucks possessed; otherwise, I am unable to understand the large number of failures of arch bars in diamond trucks of large capacity and heavy parts which I have noted. In the matter of inspection it is true that the arch bar truck permits an easier inspection of wheels than a plate truck, but the frame of a plate truck having so few vital parts, and being subject to so few failures, requires less time for inspectors and permits more time to be devoted to the wheels.

In the matter of repairs, the replacement of wheels requires more time in a truck with jaws than in the diamond truck, even considering the time consumed in handling inside wheels and rusty box bolts, but in weighing the matter we must remember the length of life of wheels in freight service.

From my point of view, a plate truck of the type represented by the Fox, Cloud and Hewitt trucks is the most efficient truck for cars of large capacity. Properly designed and built in a proper manner with the right material, they will retain their shape in service, thus reducing train resistance and flange wear. The cushioning of the entire structure above the journal boxes decreases cost of maintenance.

To come down to practical facts, the road I am connected with owns but fifty cars equipped with Fox trucks, but we handle New York Central, Erie and Lehigh Valley cars equipped with these trucks in large numbers, so that our men are perfectly familiar with them. The only failures that have occurred on our lines were two cases when the trucks first came out. The side girders failed, beginning with a fracture at the bottom flange, near the cross girder, and passing up through the rivet holes. It developed gradually. Since then we have had practically no running repairs to frames whatever on the many thousands of these trucks which we have handled. Our foremen all report satisfactory service for all such trucks coming under their observation. We know that the earlier designs developed some weakness and have been changed once or twice, and, for all I know, when they get home to the owners, they may be like the "old one-hoss shay" and break down all at once, but we have never seen anything of it. The type of truck is what I am referring to, although in talking of my practical experience with the type I am obliged to handle a particular one. It may be that none of the trucks of that type now in service are just right, but I firmly believe that the most efficient truck for the service lies along those lines, and that it can be built to last.

The body bolster is fully of as much importance as the truck bolster, although more attention has been centered in the latter. It is of little benefit to get a rigid truck bolster if your body bolster sags and permits too much weight to be carried on the side bearings, as side bearings are generally constructed. Go through any railroad yard, and what do you see? Body bolsters all sagged at the ends, especially the wooden ones. A wooden body bolster can no more be preserved in line in practical service than a wooden truck bolster can.

LIGNITE FOR LOCOMOTIVES.

In a paper before the Texas Railway Club Mr. S. R. Tuggle, Superintendent of Motive Power, Houston & Texas Central Ry., told of the results of experiments with lignite as fuel on that road. It was specially desirable to use this fuel if possible, because of an abundant supply of it in beds on the main line of the road. It was first tried for the boilers of water stations, then at the car shops and creosoting plant, and then under all stationary boilers. By changing the draft appliances and putting on diamond stacks it was found that lignite alone could be burned on switching engines, and that a mixture of about equal parts of lignite and Territory or Frisco coal was suitable for road engines. Fuel records of this road show that in January, 1896, in all classes of service, the locomotives made 29.9 miles per ton of coal at a cost of 11.06 cents per locomotive mile, while in January, 1898, corresponding figures are 28.3 miles per ton of coal, costing 6.41 cents per mile, or a reduction of 4.65 cents per locomotive mile. The following comparative figures by years were also given. Average cost of fuel per locomotive mile: 1894, 9.55 cents; 1895, 7.99 cents; 1896, 7.68 cents; 1897, 6.54 cents. Lignite was first used in 1895. Besides the saving from the reduced cost of the fuel, Mr. Tuggle said that an indirect saving was effected by decreased expenses for repairs to locomotives.

COMPARATIVE PAINT TESTS ON THE 155TH STREET VIADUCT, NEW YORK.

The plan adopted during 1897 by Mr. E. P. North, then Consulting Engineer of the Department of Public Works, New York City, for making comparative tests of various kinds of paint under the severe action of locomotive gases was outlined on page 375 of our November, 1897, issue. Mr. North having resigned his position, the work of comparison was entrusted to Mr. Henry B. Seaman, 40 Wall street, New York, whose report we are permitted to print. The girders were cleaned in exactly the same way and the 17 different paint

and having the bottom flanges about seven feet above the tops of the locomotive stacks. For convenient reference in this report, these girders are numbered from 1 to 17 consecutively, beginning at the north end.

A foot bridge, located just north of girder No. 1, also crosses above the tracks. The floor of this bridge is about four feet below the bottom flange of girder No. 1, and about three feet away from it in the clear. The 155th street station being the terminus of the railroad, the two outside tracks are in constant use by arriving and departing trains, while the middle track is used mainly by switching locomotives.

During the greater part of the day, trains arrive three minutes apart, alternating between the easterly and westerly tracks. The locomotives of the north bound trains on the easterly track stop with the stack directly under girder No. 5, and remain about 20 seconds before pulling out. Incoming

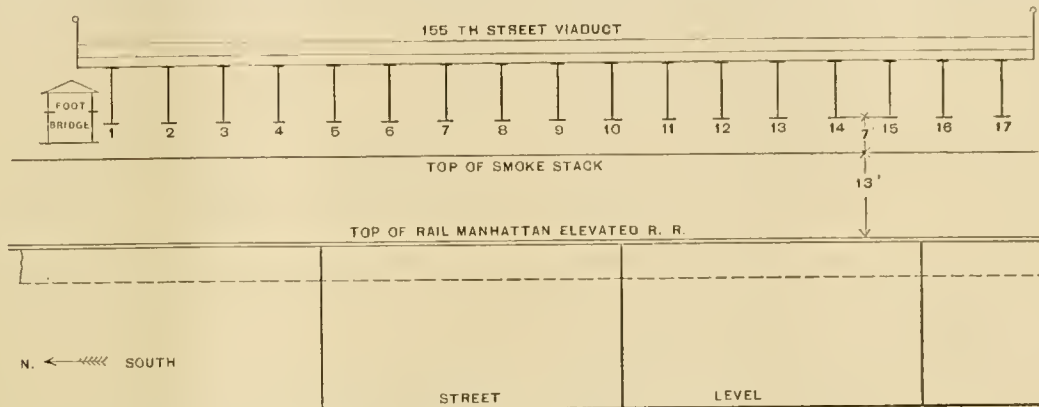

Sketch Showing Positions of Girders, 155th Street Viaduct, New York.

firms were permitted to apply their paints under equally favorable conditions, which renders this comparison absolutely fair to all. Mr. Seaman, at his own request, was not informed of the brands of paint used, nor did he know the names of the firms concerned until after the completion of the comparison.

We reproduce Mr. Seaman's report in his own words, as follows:

The knowledge to be gained from this experiment will be very valuable, and, while the paints had been exposed for less than a year at the time of Mr. Seaman's examination, the comparison given by him is interesting. It is not by any means certain that the classification of condition would be exactly the same if examined by other individuals, but these results may

trains on the westerly track do not stop until the locomotive has passed north beyond the footbridge. All trains approach the station with steam shut off, except that used for brakes. It will thus be seen that the only girders which constantly receive the direct blast of the engine are girders No. 1 to 5 inclusive, the remaining girders receiving blasts only upon the occasional switching of engines, and in making up trains. In all other cases the girders are exposed alike to only such gases as the locomotives emit while the steam is shut off.

In making the examination, a careful general scrutiny was given to each girder from the platform below, and each was given a percentage mark, denoting the amount of surface free from rust. These percentages were then carefully compared and reviewed so that they might correctly represent the comparative condition of each girder. When these results were completed, a thorough inspection was made by climbing through the structure and the character of rust noted, for each girder.

After completing the examination and recording the results,

COMPARISON OF PAINTS.

Number of Girder.	Kind of Paint.	Number of Coats.	Rate of Drying.	Percentage of Surface Free from Rust, April 12, 1898.	Remarks Concerning Condition of Paint.
1	Lead, Graphite and Lucol Oil.	3	Medium.	97	Paint crumbling in places, as though rotten. Very little rust.
2	Graphite and Linseed Oil.	2	Slow.	80	In fair condition, but discolored. Rust coming through.
3	Red lead, "Antoxide E." "Antoxide D."	2	Rapid.	25	Very badly rusted.
4	Graphite	2	Slow.	75	Rust not deep.
5	"Nobrac"	3	Medium.	99	Slight rust on top flange of one panel. Rest of girder clear.
6	"Carbon Black"	2	Slow.	85	Rust not deep.
7	"Durable Metal Coating"	2	Slow.	75	Rust not deep.
8	"Black Manganese Iron"	2	Rapid.	30	Rust very deep. Buckle plates bad.
9	"Carbonizing Coating"	2	Slow.	80	Rust not deep.
10	"Mineral Rubber"	4	Rapid.	78	Area of rust spots small. Rust very deep.
11	"Black"	2	Medium.	58	Rust bad and deep.
12	Carbon	2	Medium.	92	Rust not deep.
13	Graphite	2	Medium.	67	Rust not deep.
14	Graphite	2	Slow.	70	Rust not deep.
15	Asphalt	2	Very slow.	65	Deeply rusted. Buckle plates still good.
16	"Ruberio"	2	Medium.	58	Rust deep and angry. Buckle plates mildewed.
17	"Black Diamond"	2	Medium.	70	Small pimples of rust, as though formed under paint.

be taken as the carefully prepared opinion of a disinterested engineer.

On April 12, 1898, I made an examination of the different paints on that span of the 155th street viaduct, which is directly over the tracks of the Manhattan Elevated Railroad at Eighth avenue, and beg to submit the following report:

This part of the bridge spans three tracks and two platforms, at the 155th street station of the elevated railroad, and is composed of seventeen lattice girders carrying floor beams upon which are riveted buckle plates, which in turn carry the roadway of the 155th street viaduct. These seventeen girders are of 69 feet span and 9 feet deep, being spaced 9 to 10 feet apart,

the kinds of paint used for each girder with the number of coats and comparative rapidity of drying were obtained from Mr. M. E. Evans, C. E., under whose direct supervision the girders were cleaned, and the various paints applied. The following table gives the summary of the results:

It will be noticed, both by percentage of clear surface and character of rust on close examination, that girder No. 5 is preserved better than any other of the set. When it is also considered that the priming coat of this girder was the one first applied, that it has been the most severely exposed to sulphur fumes, and that a portion of the priming coat was applied with the humidity averaging 96 per cent. for the day (where 100 per cent. is absolute saturation), the comparative condition in favor of girder No. 5 is very marked.

Respectfully,
HENRY B. SEAMAN.

New York, May 24, 1898.

COMMUNICATIONS.

LOCOMOTIVE FRAME FASTENINGS.

Editor "American Engineer":

Referring to the recent report on the best form of cylinder fastenings for locomotives at the Master Mechanics' Convention, I send you a print showing a frame construction which seems to me far superior to anything suggested in the way of double front end frames for ten-wheel locomotives. This is somewhat like the last sketch, Fig. 31, in the report referred to, but the strong point in this arrangement is considered to lie in the fact that the main frames are slotted off together and the cylinder properly faced, and when the keys in the front cylinder fastenings are driven in place, the front end frame pulls the main frame and cylinder tightly together, thus wedging the three pieces closely by the one operation of keying.

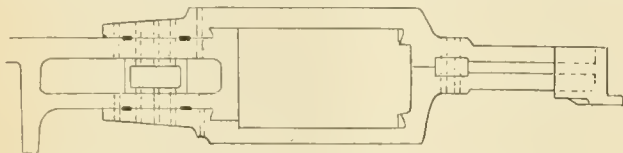

Fig. 31. - Reproduced from Report of Committee.

If this has been done properly the vertical bolts may be applied and the whole frame held securely in place; but if there are any offsets in the front end frame as shown in Fig. 31 of the report, it is likely that the effect desired will be lost by the offset of the frame itself bearing against the cylinder, and thus preventing the binding action desired between the cylinder and the main frame.

We think that this is a question of sufficient importance to interest locomotive designers, and I would be glad to hear through your columns any criticisms or suggestions upon this method.

G. R. HENDERSON,
Mechanical Engineer.

Norfolk & Western Ry.
Roanoke, Va., June 23, 1898.

ADVANTAGES OF RELATIVELY SMALL GRATES.

Editor "American Engineer":

In recent discussions of the importance of large locomotive boilers, an equally important factor has been forgotten, viz: The grate area. I ought to put this in another way in order to be understood and will say that, ordinarily, locomotive grates are too large for economical combustion and the large grate idea has been an expensive fad. The tide now seems to be setting in the direction of increasing the ratio between heating surfaces and grate areas, which I heartily approve. A comparison, printed on page 436 of the "Railroad Gazette" of June 17, 1898, shows that the grates of the Class H-3a engines, built in 1889, have much larger grates than the most recent design, Class H-4, which has just appeared. The part of the table which is pertinent in this connection is as follows:

	Class H-3a.	Class H-4.
(1) Total weight	124,800 lbs.	174,300 lbs.
(2) Total heating surface.....	1,498 sq. ft.	2,470 sq. ft.
(3) Grate area	31.5 "	29.7 "
(4) Ratio of (3) to (2).....	1 to 48	1 to 83
(5) Cylinders	20 x 24 in.	22 x 28 in.

The later design is for a bigger and heavier engine, requiring a bigger boiler, but the Pennsylvania people have reduced instead of increased the grate area, and the ratio between the heating surface and the grate area has been considerably increased. The ratio obtaining in the H-4 design is probably about right, and I want to indicate that high ratios between these surfaces have not been fully appreciated. Large heating surfaces are all right as far as they go, but the grates must be made to correspond. We do not hear enough about the grate nowadays. Most big engines with large grates will save coal if parts of the grates are blocked up by dead plates until the right ratio is obtained.

C. G. O.

July 2, 1898.

SERVICE TESTS OF AIR BRAKE HOSE.

Editor "American Engineer":

I would like to call your attention to some facts relative to air brake hose tests, which modify to some extent the tests recently recommended. The best hose for air brake purposes is manifestly that which gives the longest service. Now the tests proposed by some roads and manufacturers are empirical and mere guess work, inasmuch as they in no way are based on the service use of the hose.

The unwinding test for the friction is an instance. In place of indicating the longest lived hose, this test actually requires such a peculiar condition of the rubber as to make a very short lived hose. To meet the unwinding test, a soft, sticky rubber is necessary, which is in such a crude state as to harden in a short time, making a stiff hose very liable to crack if

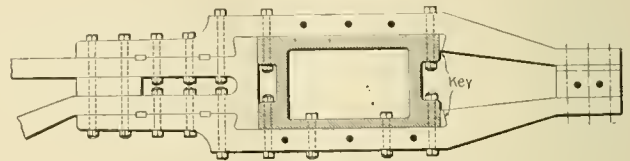

Plan Suggested by Mr. Henderson.

bent short. Some time since the writer, in company with a master car builder, took from a freight car an air brake hose that had been in use some five months, which hose was one of a lot accepted on this unwinding test. A section 1 inch long was cut from it and the 25-lb. weight applied to unwind the friction or fabric. It failed so badly as to surprise us, and indicated clearly that the condition of rubber necessary to pass this test when the hose is new is such as to harden quickly, making a hard, rigid hose in a few months of service. A hose on another car, probably costing less than the one experimented on, had been in use over a year and was quite pliable, yet I doubt if it would at any time have passed the unwinding test. Inasmuch as what a road wants is hose that will give the longest life, the logical requirements would seem to be such as demand a certain life of say two or three years or a certain mileage, as required of cast freight car wheels, which requirements have given the best and cheapest freight car wheel in the world.

Let roads require a service test of 30 months, and leave it to the manufacturer to make his hose of any mixture of rubber he deems best. By so doing better and cheaper hose will result, because so far the mixture of rubber necessary to give the largest service is not known, and for railroad officials to dictate what mixture shall be used as indicated by tests which in no way test the hose in the line of its use approaches the absurd. What the road wants and pays for is service, not a sticky, quick-changing friction, and by requiring a service of two or three years the road throws upon the manufacturer the responsibility of filling it whereas the unwinding test relieves the manufacturer of making hose that will give over six or eight months' service, and the road itself assumes the expense entailed by short lived hose. New constructions of hose will come out which cannot be tested at all by this unwinding test, and which hose will likely give three times the life of the present kinds. How then can such hose be tested save by its actual use? Does the Government, in buying armor plate, require elongation tests of samples or tensile strength tests, or does it take a plate and submit it to a test of actual service by attacking it with high power guns? Rather the latter, and by so doing that is leaving the manufacture of the armor to the manufacturer entirely, and by demanding a practical test identical with the use the armor is to be put to, it has secured so much the best armor, at the expense of the manufacturer, that foreign governments are using American armor. Let the railroads adopt similar tactics—which are identical with those which experience and common sense forced them into in the case of cast car wheels, and they will soon reach the desired end of the longest lived air hose.

MASTER MECHANIC.

July 4, 1898.

TIMBER TESTS BY THE GOVERNMENT.

The Government timber tests by Prof. J. B. Johnson, in 1897, have been recorded in a pamphlet circular No. 18, by the United States Department of Agriculture, the special field covered being the influence of the size of test specimens upon the results, the effect of distribution of moisture, and the relation of compression-endwise strength to the breaking load of beams. On page 229 of our issue of July, current volume, we printed a statement of the conclusions reached by Mr. Fernow on the discovery by Mr. S. T. Neeley, of the direct relation between the compressive and transverse strength of timber, and below we give the most important conclusions drawn from the 1897 tests. For lack of space we cannot give the complete text of the report.

Conclusions.

1. A difference in strength values derived from a few specimens of the same kind of wood, up to 10 per cent. for coniferous wood and 15 per cent. for hard woods, cannot be considered a difference of practical importance; such differences cannot be relied upon as furnishing a criterion of the quality of the material.
2. The size of the test piece does not in itself influence strength values (except in compression endwise when the size is less than a cube).
3. Small test pieces judiciously selected furnish a better statement of average values of a species than tests on large beams and columns in small numbers.
4. A large series of test on small pieces will give practically the same result as such a series on large beams and columns; hence there is no need of finding a coefficient, with which to relate the results of the former to construction members.
5. The influence of moisture on strength appears even greater than the former tests and statements from this division have indicated.
6. The strength of beams at elastic limit is equal to the strength of the material in compression, and the strength of beams at rupture can, it appears, be directly calculated from the compression strength; the relation of compression strength to the breaking load of a beam is capable of mathematical expression.

Effect of Water Soaking.—A series of 132 compression endwise tests on pieces of white pine, longleaf pine, tulip tree (poplar), oak and ash made on material which had been yard dry and then soaked in cold water for over four months, showed that this soaked material behaved very much like the green material, displayed but little less uniformity, and that the difference between soaked and dry material was about the same as between green and dry material. For purposes of investigation the green material was found preferable to soaked pieces, since much time is lost in soaking and a uniform distribution of moisture not readily attainable.

Observations and Deductions.

- (a) The difference between the values for the large beam and the average for the small beams is not at all constant, either in character or quantity; the large beam may be stronger (20 per cent. of the cases) or practically as strong, i. e., within 10 per cent. (57 per cent. of the cases), or it may be weaker and vary often considerably from the average (23 per cent. of the cases). Of 696 tests on small beams 235 furnished results smaller than that of the large beam. Again, out of 396 small beams, fully 40 per cent. were weaker than the large beam, while of another series of 300 only 24 per cent. gave lower values.
 - (b) There are in every case some small beams which far excel in strength the large beam; even in such cases where the average strength of the small beams is practically the same as that of the large beam, some small beams show values 25 to 30 per cent. greater than the large beam.
 - (c) In only 6 per cent. of the cases each of the small pieces gave a higher result than was obtained from the large beam, but in these cases the latter was evidently defective.
 - (d) In all beams the differences observed between the several small beams themselves are far greater than that between the average value of the small beams and the value of the large beam from which they are cut.
- From these observations, which are fully in accord with the observations on the numerous tests of the large general series, it would appear that—
- (1) Size alone can not account for the difference observed; and, therefore, also that a small beam is not proportionately

stronger because it is smaller, for it may be either stronger or weaker; but that if it is stronger, the cause of this lies in the fact that the larger beam contains weak as well as strong wood, besides other defects which may or may not appear in the small stick.

(2) Generally, but not always, a large timber gives values nearer the average, since it contains, naturally, a larger quantity as well as a greater variety of the wood of the tree; and, therefore, also:

(3) Small beams, for the very reason of their smallness, containing, as they do, both a smaller quantity and variety of the material, give results which vary more from the average than results from large beams, and, therefore, can be utilized only if a sufficient number be tested; but it also appears that:

(4) To obtain an average value, even a very moderate number of smaller pieces, if they fairly represent the wood of the entire stem, give fully as reliable data as values derived from a larger beam.

(5) Average values derived from a large series of tests on small but representative material may be used in practice with perfect safety, and these averages are not likely to be modified by tests on large material.

It might be added that both the practicability and need of establishing a coefficient or ratio between results from tests on large and small beams or columns falls away. To deserve any confidence at all, only a large series of tests on either large or small beams would satisfy the requirement of establishing standard values, while a series of small pieces has the preference, not only on account of greater cheapness and convenience in establishing the values, but still more for the reason that only by the use of small, properly chosen material is it possible to obtain a sufficiently complete representation of the entire log.

INACCURATE WHEEL RECORDS.

The paper on "Thermal Tests for Car Wheels," printed in abstract on page 249 of our July issue, contained a discussion of the ordinary methods of arriving at the average life of chilled iron car wheels. Mr. Bush says:

If we have, for example, 10,000 wheels in service, and experience for a period of ten years shows that in order to keep the equipment in good condition it is necessary to renew 1,000 wheels a year, it is obvious that the life of each wheel in service will be ten years; or, in other words, if the number of wheels drawn and renewed each year is sufficient to keep the equipment in good condition, the life of the wheels is obtained by dividing the total number in service by the number drawn per year.

Without considering the various influences that may come into such a calculation in ordinary practice, this may seem an entirely correct method, but it only applies when the equipment remains the same from year to year. If additions are made to the equipment a disturbing influence is immediately introduced. Also, it is assumed that the total number of wheels put under an owner's cars by foreign roads is the same as are put under foreign cars by the owning road, and finally that the mileage made by owner's cars on foreign roads is equal to the mileage made by foreign cars on the owner's road. These assumptions may or may not be true, and whatever results are obtained the figures thus deduced can at best only be approximate.

The method indicated above is quite commonly used. As showing the inaccuracies of this method, however, it is only necessary to point to the following example:

According to this method, the life of wheels drawn during the year 1890 on one road was 7.4 years, while the life of wheels drawn on the same road in 1892 was 12.4. This difference in the life is due to the fact that for two years prior to 1890 large additions had been made to the equipment without a corresponding drawing of wheels; consequently the total number of wheels in service increased very greatly, while the renewals did not increase proportionately until 1892 and after. Again, in 1892 on the same road a very large addition to the equipment took place, with considerable diminution in the number of wheels drawn. This produced a very long life for such wheels as were drawn.

It must be evident, without argument, that there is no such

violent fluctuation in the life of wheels under cars. If necessary allowances are made for the variations in the equipment, etc., above indicated, a very different result is obtained. For example:

If the average of the total number of wheels in service for five consecutive years be taken, and this sum divided by five, and the yearly average of the wheels drawn for the same five consecutive years be taken, then we obtain the average life in years for the wheels drawn, which applies with considerably greater accuracy to the last one of the five years in question. Again, if we drop the figures for the first year of the group and take the figures for the succeeding year, we obtain another average life of years corresponding to the wheels withdrawn during the last year, and so on.

If objection is raised to a period of five years, it may be stated that by increasing the period, greater will be the accuracy. The table given below shows the average life of wheels obtained on a road by each of the plans outlined above.

AVERAGE LIFE OF WHEELS IN YEARS.			AVERAGE WHEEL MILEAGE.		
Year.	Five-year Plan.	Ordinary Plan.	Year.	Five-year Plan.	Ordinary Plan.
1887.....	9	8.7	1887.....	114,836	105,824
1888.....	8.5	8	1888.....	108,280	99,080
1889.....	8.5	9.7	1889.....	106,256	115,232
1890.....	8.4	7.4	1890.....	104,056	94,436
1891.....	8.5	9.2	1891.....	105,504	108,640
1892.....	9.2	12.4	1892.....	111,924	137,776
1893.....	9.6	10.3	1893.....	113,364	109,384
1894.....	9.6	9.5	1894.....	107,496	95,134
1895.....	9.4	7.2	1895.....	102,828	80,008
1896.....	9.3	8.8	1896.....	99,446	89,083

It will be observed that the violent fluctuations produced by the first method almost disappear by using the second method, and the life of wheels expressed in years is much the same from year to year, which is really what might be expected, there being no real reason why the average life of wheels should change very greatly.

CARBON CONTENTS OF PISTON RODS.*

J. E. Johnson, Jr.

About six years ago the company with which the writer is connected bought a compound locomotive of the Baldwin or Vauclain type, no description of which is needed before this society, except to recall the fact that the high and low pressure cylinders lie as close together as possible, one vertically above the other, the rods from the two cylinders being fastened to the same crosshead, which is of the four-bar type, and located centrally between the two rods, as shown by the accompanying drawing. The wings or guiding surfaces are made very long in the direction of the stroke, to overcome the torque set up by the unequal and constantly varying pressures on the high and low pressure pistons respectively. These pressures are made as nearly equal as possible by the steam distribution, but practically there is always considerable difference at some part of the stroke, so that there is a stress tending to tilt the crosshead one way during one stroke, and the opposite way during the other. This stress, occurring while the crosshead is undergoing its regular reciprocating motion, puts a considerable pressure on the diagonally opposite corners of the guiding wings, and, the reciprocating motion going on while under this pressure, wear takes place on the corner of the wings first, and allows a slight rocking of the crosshead, a complete oscillation occurring at each revolution when running under steam.

The piston-rods are fastened to the crosshead with the regular taper fit drawn up to a shoulder by a nut. This connection being rigid, and the opposite ends of the rod prevented from vibrating with the crosshead by the fit of the pistons in the cylinder, the rods are bent at the shoulder through a very small arc in each direction vertically, at each revolution.

This first locomotive ran for three years and two months, when a duplicate was bought, and the first put in the shop for a general overhauling previous to taking the place of the smaller engines on another part of the road, the new one taking the run of the old one. During the overhauling the piston-rods were renewed, having worn down too small to work well

with the metallic packing any longer. The material for the new rods was ordinary "machinery steel," taken from stock on hand. The rods on this engine (No. 4), it should be stated, were straight from shoulder to shoulder, while those of the "duplicate" (No. 5), were reduced in the body, having a collar ¼-inch larger than the rod and ½-inch wide next to the shoulder at the crosshead end.

After having been in service about fourteen months, one of the low pressure rods of No. 5 "let go" and smashed the cylinder head, without, however, doing any very serious damage. Within a few weeks the overhauled engine did the same thing

This was becoming a serious matter, and after some careful consideration the writer ordered some genuine Swedish iron to make rods of. It was beautiful stock, and so soft that it acted almost like lead in the lathe, being very difficult to get a smooth finish on. A set of these was put into one of the engines at once and ran about four months, when one of them let go in the same way. The rods that broke were all low pressure ones, due undoubtedly to the fact that in the "emergency," or starting gear, those cylinders get almost full boiler pressure—180 pounds per square inch. The rods were all broken in the same way, and right in the shoulder the metal cracked at top and bottom, and the crack gradually widened, as could be seen by the worn appearance of the upper and lower segments of the break, which gradually approached each

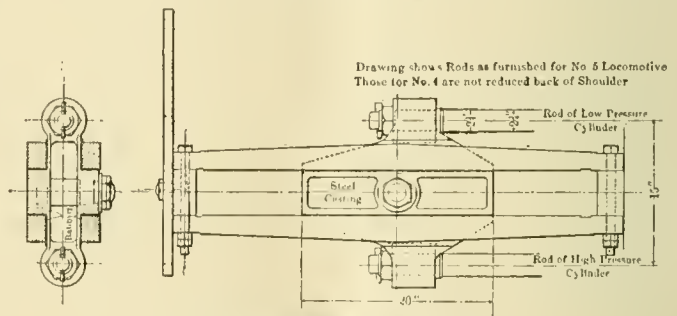

Carbon Contents of Piston Rods.

other until only a narrow horizontal strip of solid metal was left across the middle of the rod when the final rupture occurred.

Soon after ordering the Swedish iron, the writer came across one or two articles bearing upon this subject of the endurance of soft and hard steel or iron under fatigue, and describing tests made to elucidate this point, notably those of the Pope Tube Company and the Bethlehem Iron Company, which showed quite clearly that high-carbon steel was infinitely better than low-carbon, and that nickel steel was better than either for such service; also that very soft material, like Swedish iron, lacked endurance under fatigue.

Therefore the breaking of the rod of this material was not a very great surprise, and was met by ordering metal for a set of rods of high-carbon and one of nickel-steel from the Bethlehem Iron Company. These have now been in considerably over a year, and we hope that they will last long enough to wear out without breaking.

The writer had the three rods which had broken, and the one which had worn out, analyzed, to see how they bore out the theory of high-carbon material versus low.

The results are given herewith:

	Man-Sulphur.	Phos-ganese.	Phosorus.	Silicon.	Carbon.
First rod in No. 4 locomotive; machine steel; ran three years and two months without breaking.....	.094	.70	.082	.014	.466
Second rod in No. 4 locomotive; machine steel from Longdale stock; ran fifteen months and broke.....	.056	.64	.125	.021	.152
First rod in No. 5 locomotive; iron; ran fourteen months and broke.....	.020	.12	.04	.148	.129
Third rod in No. 4 locomotive; Norway iron; ran four months and broke..	.006	.95	.055	.021	.043

*A paper read before the American Society of Mechanical Engineers, June, 1898.

It will be seen that these results bear out the theory to a striking extent, there being nothing in No. 1 to cause its far greater endurance except the carbon, and possibly to a slight extent the sulphur, which is also claimed by some to be a hardener.

It is very difficult to deduce any quantitative results as to number of reversals of stress producing flexure even approximately, because even given the approximate daily mileage of the engines and the size of the drivers, it is impossible to say what portion of the daily running was done under steam, the grades being quite heavy, and the trains running by gravity for nearly half the total distance.

If 30 miles per day under steam, 28 days per month, be taken, the diameters of the drivers being 36 inches, the revolutions per day would be, say 16,000, and per month, say 450,000; this would make for the second and third rods about 6,000,000 double flexures before rupture, and for the Swedish iron rod, say 1,800,000.

There is no way of giving the amount of flexure; the cross-head probably never tilted more than 3-64 inch in 24 inches to either side of the vertical; but this amount varied as the wear occurred, and was taken up; also, it is not possible to tell what portion of the total length of the rod absorbed this flexure, so that it is impossible to give any figures having a scientific value.

ELECTRIC MINE LOCOMOTIVES.

The development of electric locomotives for the special work of mine haulage, involving many difficult problems, has been successfully carried out by the Baldwin Locomotive Works and the Westinghouse Electric & Manufacturing Company, under the direction of Mr. George Gibbs, Consulting Engineer, and the recent work in this direction is described by these con-

ism of the simplest possible character, and running parts readily accessible for replacement, the cost of maintenance is brought to a minimum.

The power for operating electric mine locomotives may conveniently be furnished from the same electric, generating plant which supplies current for lighting and other mining work, and the same wires may be made to convey the current for all purposes, thus making a simple system of distribution and reducing the attendance to the minimum.

The extended experience of the Baldwin Locomotive Works in the manufacture of steam and compressed air mining locomotives assures careful design of the mechanical features of the locomotives, while the well-known excellence of the electric railway apparatus of the Westinghouse Electric & Manufacturing Company guarantees that the especially designed motors for these locomotives embody the latest improvements in electric practice.

In designing a series of electric locomotives the range of practical requirements has been considered, and the table of sizes and powers given is intended to embrace apparatus covering all usual needs. It has been thought expedient to exclude abnormal specifications, as, for instance, gauges of track so narrow as to make the locomotive a mere toy, or locomotives of great power on narrow gauges, thus necessitating cramping the design of the motors or rating them above a safe working limit.

The general design is shown in the engraving. The locomotive frame consists of heavy cast-iron side and end pieces securely bolted together and kept square by machined joints and shoulders accurately fitted. These frame pieces are planed at top, bottom and ends, to insure perfect accuracy in fitting up and interchangeability of parts. The pedestal caps are forgings made to templet, and accurately fitted, so as to relieve the frame from breaking strains in case of severe

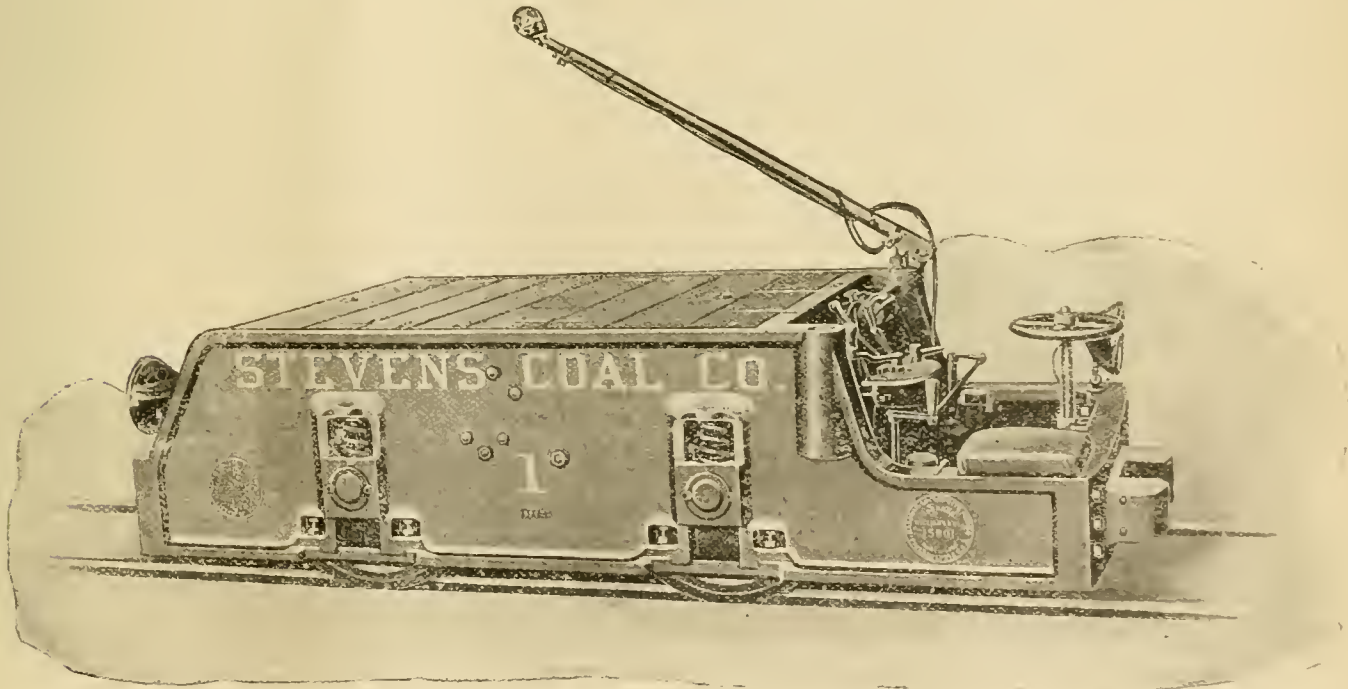

Baldwin-Westinghouse Electric Mine Locomotive.

cerns in a pamphlet, from which the following information is taken:

Electricity has become established as the most convenient and economical form of motive power for mine haulage. It is especially suitable because of its flexibility, permitting ready extension or change as mining conditions frequently require.

The compactness of the electric locomotive makes it perfectly adaptable to low and narrow entries; and, by reason of the absence of moving parts exposed to external injury, mechan-

isms. The frame is placed outside of the wheels, thus allowing all possible space between the wheel hubs to admit the greatest practicable width of motor. This feature is of much importance in obtaining the maximum power on narrow track gauges. Furthermore, this construction permits of ready accessibility to the journal boxes, and protects all moving parts in case of derailment. Heavy planking with hinged doors is laid on the top frames, thoroughly protecting all electrical parts, but permitting access to them for inspection. End

bumpers and coupling hooks are provided in conformity with requirements.

The journal boxes are of ample dimensions and have bronze bearings with oil cellars for sponging, as in steam locomotive practice. The brake apparatus, which is fitted to all wheels, is of simple design and of sufficient power to utilize the track adhesion due to the weight of the locomotive. The operating platform is placed at one end, and is compactly and conveniently arranged so that the motorman has all levers within easy reach without leaving the seat. The entire machine, with electrical apparatus, is supported on the journal boxes by helical springs, which prevent destructive pounding on the track and relieve the machinery from shock. The locomotive is driven by two spring supported motors, one geared to each axle by single reduction gearing running in oil lubrication in tight cases. These motors are designed especially for mining

condition of track and rail. Curves offer considerable additional resistance to the movement of locomotive and cars, and must be taken in account if o. short radius, especially when they occur on grades. With track in fair condition curve resistance may be taken at one pound per ton of train weight per each one degree of curvature.

For average favorable mining conditions the friction may be taken at 30 pounds per net ton weight of loaded cars, but it may frequently amount to 40 pounds per ton, or more where conditions are unfavorable, and this latter figure should be taken in making calculations. To find, therefore, the number of tons (2,000 pounds) of train which can be hauled by a given locomotive: take from table the number of pounds draw-bar pull which will be exerted by the locomotive on the limiting grade in the mine, and divide this figure by the train resistance in pounds per ton on the grade; the quotient will be the weight of train hauled. The train resistance per ton is found by multiplying the per cent. of grade by 20 pounds and adding 40 pounds friction to the result. For example: a

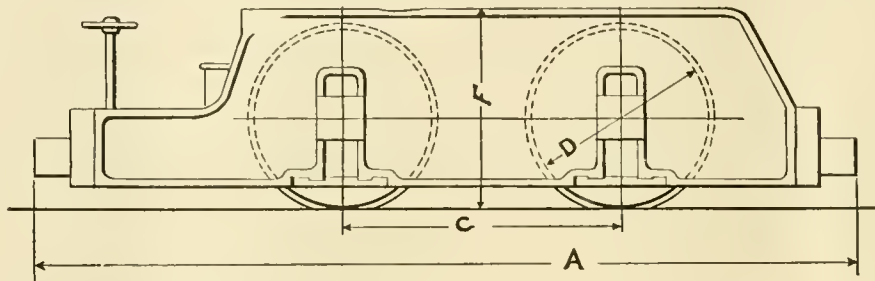

Performance and Limiting Dimensions of Mining Locomotives.

Class.	Total Horse Power.	Speed M. P. H.	Full Load Draw-Bar Pull in Pounds.				Minimum Track Gauge	Wheel base C.	Diam. of Wheel D.	Width.	Length A.	Height F.	Weight.	
			Level.	1 p. c. Grade.	2 p. c. Grade.	3 p. c. Grade.								4 p. c. Grade.
4 ¹ / ₀ C.....	20	8	900	849	780	720	660	21	41	21	41	10 4	33	7,000
4 ¹ / ₁₀ C.....	20	8	900	840	780	720	680	30	41	28	41	10 4	33	7,000
4 ¹ / ₁₅ C.....	30	8	1,250	1,170	1,090	1,010	930	30	44	28	47 ¹ / ₂	10 4	33	8,500
4 ¹ / ₂₀ C.....	50	8	2,100	1,980	1,860	1,740	1,620	30	44	30	48	10 4	33	12,000
4 ¹ / ₂₅ C.....	70	8	2,900	2,730	2,560	2,390	2,120	36	48	30	53	11 6	34	17,000
4 ¹ / ₃₀ C.....	100	8	4,300	4,060	3,820	3,570	3,340	36	48	30	53	12 0	36	24,000
4 ¹ / ₃₅ C.....	150	8	6,500	6,160	5,820	5,480	5,140	50 ¹ / ₂	60	36	74	13 6	42	34,000

service and are of the four-pole, steel-clad, inclosed railway type. The armature is of the iron clad type, the coils being held in slots below the surface and cleared from displacement, as in the most approved railway practice. The current controller is the latest rheostatic type, with magnetic blowout to prevent arcing at the contacts. It is provided with six speed changes, and is operated by handles for starting and reversing. The rheostat or "diverter" is of a non-combustible type, very compactly set up, and has large carrying capacity. The trolley pole is specially designed for this service; is reversible, and can be placed in a socket in either side of the frame, and automatically adjusts itself to varying heights of trolley wire. It is thoroughly insulated to prevent shocks to the operator when being handled, and the current connections are made by insulated cable.

The locomotive is provided with all necessary minor electrical fittings, such as fuses, lightning arrester and main switch and two electric headlights.

All sizes of locomotives are designed to run at a standard speed of eight miles per hour when developing their full load tractive effort. With light trains, requiring less than full load upon the motors, the speed may be increased. When starting, the train is brought gradually up to full speed by means of a controller. All of these locomotives are rated conservatively, and will develop the net draw-bar pull, shown in the table, under ordinary running conditions. The table gives standard sizes of mining locomotives, with their performance, weight and minimum dimensions. The draw-bar pull has been figured at full load and standard speed for the locomotives handling trains on a straight level track, and also on the limiting grades pertaining to ordinary mining practice, the adhesion of the locomotive being that found with fairly good con-

dition class 4 2-10C locomotive on a 2 per cent. grade exerts 780 pounds drawbar pull; train resistance per ton is $20 \times 2 + 40 = 80$ pounds. Then $780 \div 80 = 9.75$ tons train (cars and lading) hauled.

EXPERIENCE WITH THE METRIC SYSTEM.

Reports of satisfactory experience with the metric system by manufacturers are interesting on account of their bearing upon the question of the difficulty in introducing the measures into shop work. The following is the expression of opinion of Captain Sankey, of Messrs. Willans & Robinson, manufacturers of the well-known Willans engine, contained in a paper read some time ago before the Institution of Civil Engineers (England). The subject is before the American Railway Association, and we shall soon print an article showing how the change to the metric system has been brought about in other countries. Captain Sankey said:

"No difficulty has been experienced in getting draftsmen to use the new measures. No serious mistakes have been traceable to the change, and very few minor ones. The draftsmen are practically unanimous in favor of metric measures, finding it easier to design, to check and to read millimeter drawings. Taking all fractions into account, little more than half the number of figures formerly used are now required to express a dimension. No mistakes have been made in marking off work to millimeters. The men preferred the old system at first, the new figures conveying little idea of size, but they are now much in favor of the millimeter, and find drawings so figured easier to read. The shop where the difficulties of the change would be most felt is that in which the tools and gauges are made; the foreman says that it was a little awkward at the outset—for about two days. In the works manager's opinion the metric system would prove even more advantageous in shops where measurements are taken from the rule than where gauges are used. He considers it easier to teach men the use of the rule with the metric than with English measures."

THE DIESEL HEAT ENGINE.

This comparatively new gas engine is much better known in Europe than in this country, but it is now being brought to attention and is creating a great deal of interest here. The Diesel engine uses petroleum, but it may use gas when necessary. It is the result of years of investigation and experiment by Mr. Rudolph Diesel, a German engineer of note, and some of the claims made for it are given below. There has been much difficulty in the ignition of charges of gas in these engines, and Mr. Diesel has dispensed with the spark or igniting tube and secures the ignition by means of the compression itself. Pure air is compressed to a high degree and then the fuel is introduced into the cylinder and it burns steadily during the stroke of the piston at practically constant temperature.

In the best triple-expansion steam engine over 1,000 horsepower as developed up to the present day, says Mr. Diesel, only 12 or 13 per cent. of the heat energy contained in the fuel

point of cut off being imitated by the stopping of the fuel supply, the burnt gases then expanding adiabatically to the point of release, fresh air being compressed again up to the temperature of ignition for the introduction of the new charge. It is obvious that this is virtually a Carnot cycle, but it is necessary to deviate from a perfect cycle by expelling the expanded charge and taking in a new supply of air for compression, instead of isothermally giving heat to a continuously used charge of air from the walls of the receptacle at a high pressure, expanding it adiabatically, taking the waste heat isothermally from it at the lower pressure, and finally compressing it adiabatically to the temperature of the source of supply. Mr. Diesel also claimed that combustion should be carried on with a considerable surplus of air, the amount of which can be determined theoretically, instead of with as little surplus as possible.

In such an engine there are great possible advantages of superiority over the steam engine. No steam boiler is used; there is, therefore, no loss of heat in the flue gases or by

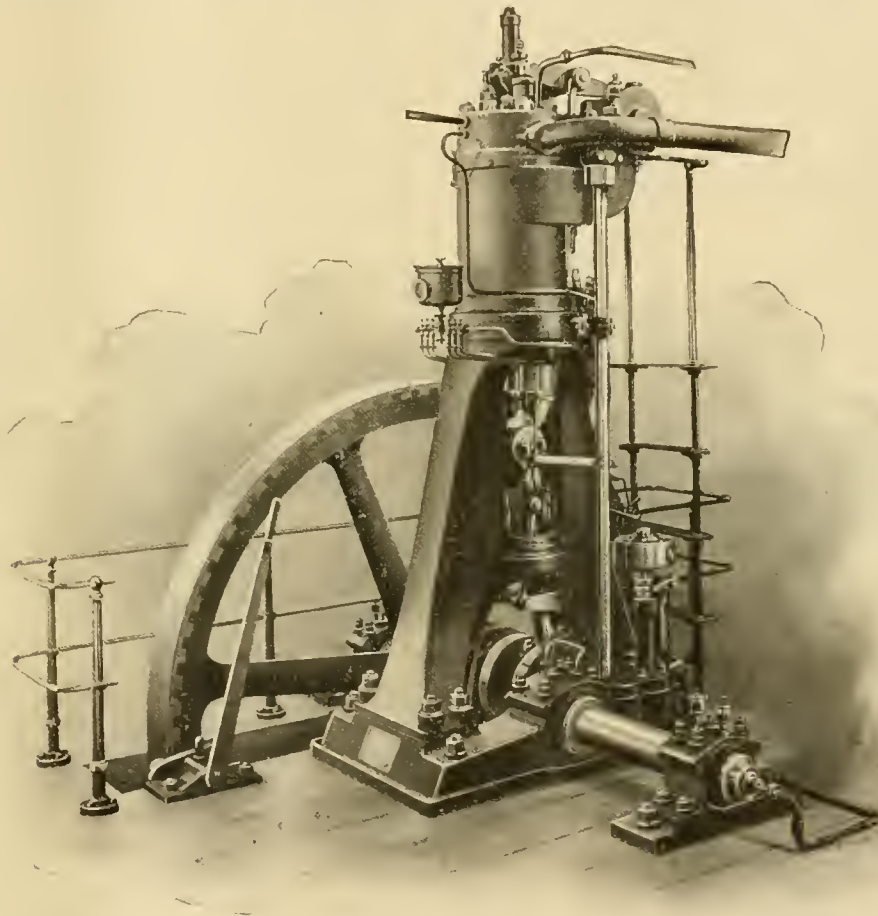

Fig. 1.—A 120-Horse-Power Diesel Motor.

is converted into available work, less than 10 per cent. being developed from smaller sized compound engines, 5 per cent. from small condensing engines, and even less in ordinary units not very carefully handled. The losses occur at several points. In the first place, the efficiency of the boiler is below 80 per cent., generally about 75. The theory of the steam engine shows that only a part of the energy of the steam can be converted into work even in a perfect machine operating between given steam pressures. This ratio may be 30 per cent. in a good engine, but no engine ever indicates much more than one-half of this, and finally there are losses between the indicated power and the brake power.

In his experimental work in attempting to design a more simple and economical engine in which the combustion is effected within the working cylinder, Mr. Diesel set forth several conditions necessary of fulfillment. The first of these was that the temperature of combustion must be generated not by the burning of the fuel, but before and independent of it, by mechanical compression. A second condition was that the fuel must be introduced gradually into this compressed air and in such a manner that the heat generated by gradual combustion shall give to the indicator card an admission line similar to that of the steam engine card, the

boiler radiation, nor steam pipe condensation. The maximum available theoretical efficiency for such a motor is greater than that of the steam engine, owing to the possibility of using higher pressures, and consequently a higher range of temperature. This theoretical efficiency varies from 50 to 75 per cent. There is no cylinder condensation, and several other sources of loss are abolished. The mechanical efficiency is, however, likely to be a little lower than that of the steam engine, owing to the high compression necessary and consequent transmission and retransmission of energy between the piston and the fly wheel.

The experimental engines so far constructed have been of the single-cylinder, four-cycle, single-acting, vertical shape, one of which of 20 horse power was tested with petroleum in the early part of 1897. This engine is provided with a ring piston and separate cross head, water-jacketed and provided with poppet valves operated by cams for admission and exhaust. A small pump is attached which keeps an auxiliary vessel filled with air compressed to a higher pressure than that obtained in the cylinder. This serves to inject the fuel, and also to start the engine.

With an engine of 20 horse power working with refined liquid petroleum, the maximum available theoretical efficiency was

about 50 per cent. and the actual ratio of indicated energy to the total energy of the fuel was about 35 to 40 per cent., showing an indicated efficiency of the engine as such of 70 to 80 per cent. The mechanical losses of this engine varied between 25 and 30 per cent. on high loads, giving over 26 per cent. of the total heat of the fuel as available energy at the shaft. With reduced loads the mechanical efficiency, of course, falls off, but the thermal efficiency, owing to the greater expansion, increases, thereby counterbalancing to a large extent the other and rendering the consumption of fuel per horse power low at all but the lightest loads. Owing to the high pressure employed in this engine also the cylinder dimensions are from 30 to 50 per cent. less than those of gas engines of the explosion type.

The governing of the speed is also as simple and easy as that of the steam engine. The exhaust gases are noticeably invisible and nearly odorless during ordinary running, owing to the perfect combustion, which also prevents fouling of the interior of the engine.

Fig. 1 shows a general view of a 20 horse power motor. Figs. 2 and 3 are cross sections, while Figs. 4 and 5 show a side view and plan of the valves. The description of the operation of this motor is as follows:

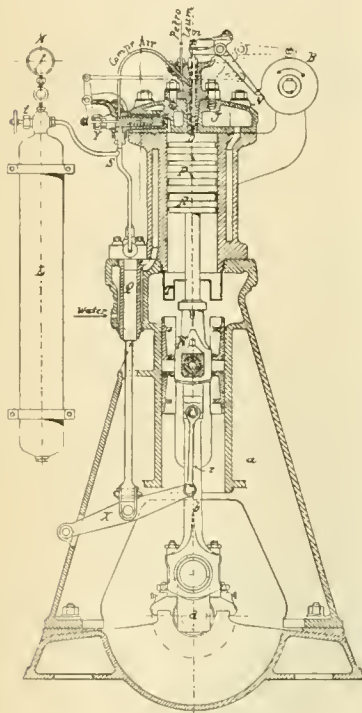

Fig. 2.

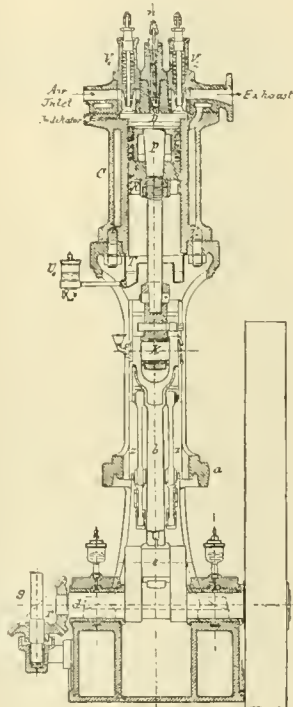

Fig. 3.

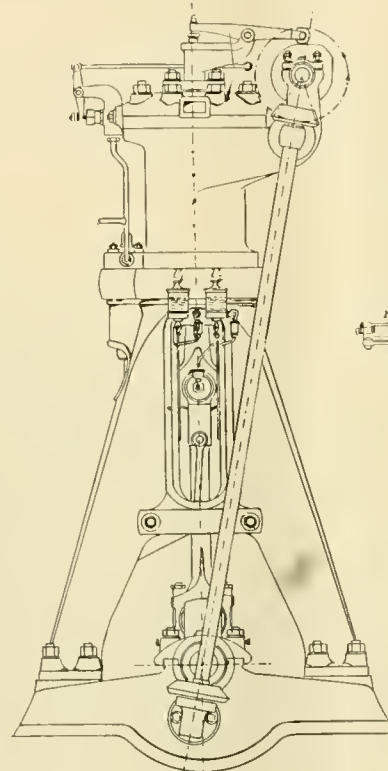

Fig. 4.

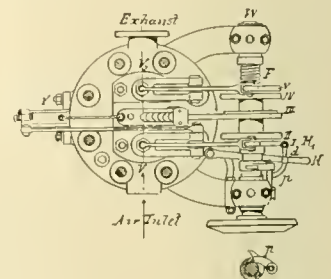

Fig. 5.

The Diesel Motor.

Pure air is compressed in the cylinder of this motor, thus generating a temperature of about 600 degrees C. The fuel to be used, such as gas, petroleum or powdered coal, is thereafter injected into the compressed air, where it is gradually and completely burned up at a much lower temperature than ever before accomplished. During combustion and during the succeeding expansion, it is entirely turned into work. The injection and combustion of the fuel takes place as the piston in the cylinder begins its return stroke. It ceases when it has reached about one-eighth or one-sixth of its way back, and it is so regulated that the increase in the temperature created by the compression of the air and subsequent combustion of the fuel is reduced by cooling off due to the work done during the succeeding expansion. Thus, practically there is no increase in sensible heat, since the heat caused by the combustion of the fuel is immediately turned into power and the motive power thus gained is only reduced by the small amount required for the compression of the air.

The small air pump Q, driven by connecting rod Z and lever X, keeps the vessel L filled with compressed air under a higher pressure than the highest compression attained in the cylinder, and is a new detail. By means of the pipe connection S the same excess of pressure is connected with the interior of the injection valve D. In it the petroleum is collected during the intervals in the four-cycle period between the combustion periods. This petroleum is introduced by a little pump, not shown in the figure. By opening the valve stem n, the fuel is by its high pressure caused to flow through the nozzle open-

ing D to the combustion chamber of the engine, thus creating the combustion period, wherein the form and length of the combustion line can be altered, according to the performance of work, partly by changing the regulation of the fuel supply, partly by changing the excess of pressure in the vessel L, and finally by performing the injection at different points on the compression line.

The Diesel motor has been patented in all countries where patents are granted for inventions, and the rights for the United States and Canada have been acquired by a company, since incorporated under the laws of New York State, as the "Diesel Motor Company of America," with offices at 11 Broadway, New York.

EDUCATION OF THE APPRENTICE BOY.*

It is my conviction that the question of a scientific education is the most important part of our work. I will confine myself to that aspect of the subject. I am particularly interested in

it, because I have taught the apprentice boy in science schools for many years, and my experience of the benefits resulting therefrom have been most satisfactory, both to the pupil and the railroad company.

It is a long time since I taught in those schools, but I recall the names of many of my pupils, some of whom never got beyond the work bench, but others who were talented have risen to high positions entirely through the knowledge acquired in those evening classes and the stimulus to reading and study which they naturally obtained through attending such schools. My experience, therefore, has altogether been in favor of educating our boys, not expecting that they will all attain responsible positions, but because even those who are dull will become better workmen, and the few who possess real ability will be separated from the ordinary mechanic and given an opportunity to rise above their surroundings and do better work in the world. If only for the sake of these few and for the good work which they will do in our profession and for our country, we ought to put forth every effort to make it easier to obtain a scientific education, and by largely increasing the number of schools make it more universal than at present.

I believe, therefore, that the importance of the question of educating our apprentices cannot be overrated. It is a large subject and one of which a broad view should be taken. It is of national importance, the prosperity of our nation largely

*A letter from Mr. G. R. Joughins, Superintendent Motive Power, Intercolonial Railway of Canada, to a committee of the Master Mechanics' Association June, 1898.

depends upon it, because educated workmen are the backbone of a manufacturing country, such as ours. I am, therefore, deeply convinced that we ought to do all that is possible to impress upon others the great value of the work and induce them to give a helping hand to push it along.

It appears to me that as the Master Mechanics' Association is a national organization, it has an excellent opportunity to do good work. It can make its influence felt more extensively than any other body; it can recommend courses of teaching and obtain uniform results throughout the United States which no Federal authority, State college or university can do.

I do not agree with those members of the association who suggest that each apprentice should pay the full cost of instruction and that he should depend on his own manly efforts for an education. That principle is not applied to the education of anyone else, no matter what school, college or university he may attend, or what profession he may adopt. I believe it to be absolutely necessary to assist apprentices, and to assist them very substantially, both in school fees and in books. Various ways can be taken to raise money to help them, without making it a serious burden upon the railroad companies; it is done at the present time in some places, and could be done in all.

With enough money it is, in most places, easy to obtain a teacher; and in those places which are too small to support one the correspondence school could be used, but the necessity of giving assistance to the apprentices, in whatever way the education may be given, will always remain.

Having persuaded our members and the roads they represent to raise the funds necessary, the Association ought to map out a plan of education, naming the subjects in which examinations will be held and giving a list of the text-books, thus insuring uniform teaching. Then at the end of the session examinations should be held at the different schools, using the same examination papers, which could be prepared by some of our college friends, who so kindly offered to help, and which each school could order at cost price from the Secretary of the Master Mechanics' Association in sufficient quantities to suit. In this way a system of certificates of acquirements could be issued on a uniform standard, and which would prove of incalculable value both to the employer and employee.

Intimately related to the school question is the establishment of a technical library, which, no matter how small the beginning, could be gradually built up.

The Association should also find out what scholarships for mechanics, mathematics, etc., are given in each State or college for which our apprentices might compete, and publish them, special stress being laid upon the existing Master Mechanics' scholarship at Stevens Institute.

If the proposed plan should meet the approval of the committee, and nothing better be offered, I have no doubt but that it could be carried out. The first step toward the desired end would probably be to issue a circular to all members of the Association, giving an outline of the work which ought to be done, and of the possibilities in the direction of a better education for our apprentices; we would then ask what educational facilities are already afforded in each shop or town, including the Y. M. C. A. courses; also details as to what deficiencies experienced, books used, cost of courses, and what assistance or encouragement is given by the railroad company or officials. After receiving and digesting the answers—which should be returned promptly—to these questions, we might be able to issue a circular pointing out the different ways in which funds can be raised, pointing out the importance of the subject, and asking each member or each railroad company what they would be willing to do toward the desired end.

The proposed science schools would not, of course, be confined exclusively to locomotive railroad apprentices. Apprentices from other shops who wished to join should be heartily welcomed on an equitable financial basis. Other organizations might wish to join in the plan of education, and should be encouraged to do so, but in the meantime the Master Mechanics' Association should go forward in the good work, and we, as its committees, should find out what ought to be done, what the railroad companies are willing to do, and make the best recommendations within our power to further the highest interests of the apprentice, which no doubt lie in the direction of a scientific education side by side with careful training in the workshop.

THE NEW BATTLESHIPS.

The Navy Department has issued advertisements for bids for the three new battleships authorized by the recent appropriation, and these will be opened September 1. The ships will be required to be completed within 33 months after the contracts are signed, and inducements will be offered for completion in a shorter time than this. Three years is the shortest

time that has been specified heretofore. The new ships will combine what are considered to be the best features of the "Oregon," "Indiana" and "Iowa," all of which have proved their value and efficiency.

The new ships will be similar to the "Illinois," "Alabama" and "Wisconsin," now building. The "Iron Age" states that the Secretary of the Navy has christened 35 war vessels authorized by the Naval Appropriation bill. One of the battleships is to be called the "Maine," as provided for by act of Congress, while the other two will be known as the "Ohio" and "Missouri." Four protected monitors are to be called the "Arkansas," "Connecticut," "Florida" and "Wyoming." The first of the torpedo boats has been named the "Bagley," after the young ensign who was killed on the deck of the "Winslow" off Cardenas. Other torpedo boats will be known as the "Barney," "Biddle," "Blakely," "De Long," "Nicholson," "O'Brien," "Shubrick," "Stockton," "Thornton," "Tingey" and "Wilkes," all well known naval heroes. The 16 torpedo boat destroyers are named after naval officers of even greater renown, including "Bainbridge," "Barry," "Chauncey," "Dale," "Decatur," "Hopkins," "Hull," "Lawrence," "MacDonough," "Paul Jones," "Perry," "Preble," "Stewart," "Truxtun," "Whipple" and "Worden."

SELLERS' FEED WATER STRAINER FOR LOCOMOTIVES.

A simple, compact, durable and easily accessible strainer for attachment to the feed hose connections between locomotives and tenders has just been introduced by William Sellers &

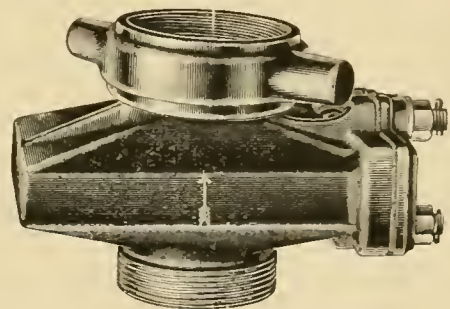

Fig. 1.—Sellers' Feed Water Strainer Ready for Use.

Company of Philadelphia. The whole device is so short in the body as to permit its insertion in the hose connection without any changes in the length of the hose, and the strainer plate, which is flat and of thick copper, provides so many one-six-

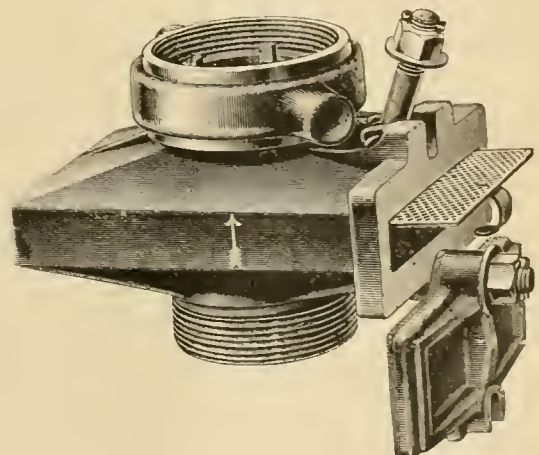

Fig. 2.—Strainer Opened for Cleaning.

teenth inch straining holes that half of them may be clogged without restricting the supply of water that the hose will carry. This plate is 5 by 7½ inches in size, and may be removed from the opening at the bottom of the casing, which is

made large enough to permit of cleaning the interior of the casing easily. The casing is strong and heavy, and the attachments of the covering plate are conveniently loosened for opening, as may be seen in the engravings. One of the fastenings is a fixed stud and the other a swinging bolt, both being attached to the casing to guard against loss when the cover is opened. It will be noticed that the only removable part is the strainer itself and its gasket, everything else being permanently attached to the casing. The hose attachments are those in general use, and the design was carried out in every particular with a view to avoiding the annoyances often caused by defective appliances of this kind. In service it has been very satisfactory.

CAR LIGHTING FROM THE AXLE.

The National Electric Car Lighting Co., Mr. Max E. Schmidt, President, equipped a number of cars on the Atchison, Topeka & Santa Fe Railway with its system of lighting by electricity from the axle last year, and the service has been so satisfactory as to result in an increase in the equipment. It is stated that ten additional cars will be lighted in this way at once, but we believe that more than this number will be fitted with the apparatus. It seems likely to come into general use on this road. The officials seem to be highly pleased with the light and also with the apparatus. Mr. Depew's private car, No. 100, on the Vanderbilt lines, has been lighted with this system for a number of months, and the enjoyment which he takes in fast running has given the system a severe test, which it has met satisfactorily. The lighting company is sparing no trouble or expense to improve its system, and we are informed that a test is now being made with a newly developed system of transmission of power from the axle, which does not require a belt between the axle pulley and the dynamo. The new plan seems to be very promising.

PAINTING CARS BY COMPRESSED AIR.

In a topical discussion on the above subject before the Master Car Builders' Association, Mr. F. W. Brazier, Assistant Superintendent of Machinery, Illinois Central Railroad, made the following remarks:

"Paint Applied to Freight Cars by Compressed Air," as compared with paint applied by the brush, is a question which our company has taken great interest in. We are repainting about 400 cars a week with compressed air. We are positive that we are getting better results, a saving in labor, and our cars are painted more thoroughly than with a brush. We have cars that have been painted about two years, and in order to get reliable information for the benefit of this association I sent out inquiry letters all over our system to have our foremen painters inspect any cars that they could find that were painted with air. We found most of the old school painters opposed to the air system when we inaugurated it. Our painters report as follows:

"After making close observation of several cars done by air and by brush, I find but very little difference in them, and, if any, it is in favor of the cars done with air."

"Cars painted by air look equally as well and show no more sign of giving way than those done by brush; therefore think air best on account of cheapness in applying."

"Our master mechanic at Water Valley says that on examination of cars painted with air within the past two years: 'I find the surface of the cars in better condition than cars painted with brush. The reason for this I attribute to the fact that the spraying of the paint with air fills the cracks of the wood and between the joints of siding better than the brush will do, as men are apt to be careless with the brush in painting and overlook joints in beading.'"

"Another says: 'The process is of much value in the expeditious and economical covering of that class of equipment. The driving of the pigment against a surface of lumber by air pressure is an advantage in the fact that all portions are covered, beading, cracks or any such openings, due to the wear of a car in normal condition. My inspection of cars painted by air process has led me to believe that in point of durability the hand process is largely discounted.'"

"The following letter from our painter in Chicago shows his opinion and inspection of cars in the West: 'After inspecting work that had been painted six months I felt pretty well satisfied that we need have no fear from the results from this method of painting, and now after inspecting work that has been out nearly two years I feel perfectly satisfied that work done by compressed air will surely wear as well if not better than brush work. There is one particular advantage that paint applied by air has over brush work, and that is that it reaches every possible opening, being driven into the open grain of the wood farther, into all cracks, beads and many places where it is impossible to get with the brush, thereby more effectually sealing the wood, iron or whatever you may

be painting to all exposure. Air applied paint in time becomes very hard, and although it becomes hard it does not get brittle, but seems to retain its life, and does not seem to chalk and perish like ordinary brush-applied oil paint.'

"In conclusion I wish to state that I have personally inspected hundreds of cars done by compressed air, and I feel safe in saying that we got far better results from air as far as wearing qualities are concerned. I think that air is desirable from the fact that we get our cars painted with a great saving in labor."

LUMBER SPECIFICATIONS FOR FREIGHT CARS.

A portion of the discussion by Mr. Pulaski Leeds on the above subject before the Master Car Builders' Association was printed on page 220 of our July issue, and we now give other portions of his remarks on specifications as follows:

Having been delegated to make some suggestions relative to the subject of lumber specifications for freight cars, I note that the committee indicates that this should be confined to dimensions, but, in my opinion, it would be fully as essential that the quality should be specified first, and have taken the liberty to outline what, in my opinion, would enable us to obtain a class of lumber suitable for our needs, without working a hardship upon the mill men or increasing the price on account of unnecessary requirements. With such specifications, which give the poorest grade that would be accepted, there should not be any question between mill men and inspectors.

Rules for Inspection of Lumber for Mechanical Department.—All lumber must be manufactured from sound, growing timber, true to dimensions, straight grained, and free from bark edge, splits, shakes, rot, worm holes, loose or rotten knots, or sound knots above the dimensions given, or so located as to materially impair the strength or durability of the piece.

In framing material, where the cross section is 4 by 8 inches and upward, sound knots $1\frac{1}{2}$ inch in diameter will be allowed if not less than 3 feet apart and not less than one-fourth the width of the piece from the edge. Pieces which contain the heart center must be cut so the center of heart will not be less than 2 ins. from either side or edge. Pieces which do not contain the center heart, as above, shall not be sawed less than 1 inch on side or edge, or 2 inches on corner from center. Bright sap will be allowed to the extent of $\frac{1}{2}$ inch, measured at its least depth, provided that when on the side of a piece the poorest edge shall show three-quarters of thickness sound heart; when sap is on one corner of a piece it must show two-thirds the depth and one-half the thickness of good heart timber; when on two corners it must show sound heart three-quarters of width and depth, respectively, on poorest edge and sap side; when it shows on four corners the edges must show three-quarters, and the sides seven-eighths of heart timber.

In smaller dimensions the knots and all other defects must decrease in proportion.

All main sills, side plates, side boards, running boards, ridgepoles, purlines and pine flooring, when of long leaf yellow pine, must be cut in the States of Georgia, Florida, Mississippi or Alabama.

Side boards, flooring, running boards, ridgepoles, purlines, etc., must have one entire heart face, and not less than three-quarters the width on opposite side, with one-half the thickness on both edges heart.

Siding and lining for freight cars should be ordered in 1 by 4-inch strips, or proper widths to make them, and such strips should have one clear heart face; bright sap on opposite side, one and two sound knots $\frac{3}{4}$ inch diameter to each strip of 8 feet in length will be accepted. When ordered in wide boards the inspection will be in accordance with this. This timber must be free from pitch streaks and pockets.

For Winslow roofing in strips of 6 inches wide, bright sap to the extent of one-third the width, and two sound knots $\frac{3}{4}$ inch diameter in a piece 5 feet long will be admissible, if not near the edge.

For double board roofing, one face must be clear heart and free from knots, opposite side and edges not less than one-half heart.

Stock boards 10 inches and over will be accepted with perfectly sound knots of 2 inches diameter, if fairly intergrown to prevent falling out, to the extent of three in a length of 12 feet, if not located near the edge. Sap should not exceed one-third width of board on either side.

Common boards can be all bright sap if clear from knots, or one-half sap with sound knots, as in stock boards.

On orders for oak, nothing but white or burr oak will be accepted.

Blue sap will not be accepted in anything, but in common boards a slight stain will be admissible.

As these rules are descriptive of the poorest quality that will be accepted, it is expected that at least 75 per cent. of each shipment will be of superior quality.

LARGE LOCOMOTIVE BOILERS.

In discussing the importance of large capacity in locomotive boilers before the Master Mechanics' Association, Mr. M. N. Forney made the following suggestive remarks:

This subject has been before the association a great many times, and it has been discussed under many different aspects. So far as my own observation and thought is concerned, my ideas may be summed up in the one brief statement that within the limit of weight and space to which you are necessarily confined in the locomotive you cannot make the boiler too big. D. K. Clark a good many years ago expressed the general proposition that the larger the heating surface the greater the economy, and the smaller the grate surface, provided you can burn enough fuel, the greater the economy. These propositions have sometimes led to a wrong deduction so far as the grate surface is concerned. People have drawn the inference that if a small grate surface is desirable a small firebox is desirable. While I think a reduction of the grate surface will often result in an economy of fuel, yet at the same time I would think it desirable to maintain a considerable volume within the firebox to give room for combustion to take place. The proportion of the grate to the quantity of fuel to be burned is a matter of much importance, and about which we have no accurate information. There is probably no direction in which so much economy can be effected as right here with proper and careful experiments. My experience has taught me this general fact, that the larger the locomotive boiler is the better results you can get—a good, reliable boiler is worth all the rest of the machinery you can put on a locomotive.

BODY BOLSTERS AND SIDE BEARINGS.

The views of Mr. A. E. Mitchell, superintendent of motive power of the Erie Railway, upon the importance of keeping trucks and car side bearings out of contact were printed on page 229 of our July issue, and the figures which he gives are interesting and specially valuable on account of the fact that they were prepared with the assistance of a dynamometer car to record the differences in power required when the side bearings were in contact and when they were clear of each other. Mr. Mitchell experimented with two trains of practically equal weight, one of the trains having 100 per cent of the side bearings clear of each other and the other having only 12 per cent in this desirable condition. It was found that the difference in drawbar pull was 7.6 per cent in favor of the first train, and the difference in fuel consumption was 8.3 per cent in favor of the clear side bearings. Mr. Mitchell says: "These figures show you the enormous saving which can be made if the cars are all center bearing."

This is no new discovery, but railroad men are certainly indebted to Mr. Mitchell for this painstaking method of ascertaining the standing of this question upon a basis of dollars and cents. It is a question of grave importance and should have immediate attention.

The discussions of the subject point to weakness in the construction of cars resulting in undue deflection of the body bolsters. This may be partly remedied by a better distribution of the loads in their transmission to the bolsters so that the center of these members will receive their proper proportion of weight, but even this will not answer unless stiff bolsters are provided. In talking the subject over with Mr. W. S. Calhoun, of the American Steel Foundry Company, it was made apparent that this company among others has foreseen the difficulty with weak bolsters and has for a long time been preparing to meet it by introducing bolsters which will hold loads of large capacity cars without troublesome deflections. We shall have more to say about this type of cast steel bolster in connection with recent improvements on several railroads, but will take this opportunity to note that by making stiff bolsters in one piece a large number of small parts are avoided, and the result, with good designing, ought to be bolsters that will far out-

live the cars themselves. For instance, there are no separate center plates in these bolsters, and even if the center bearings should wear down slightly it is a very simple matter to chip off the tops of the truck bolster side bearings to correspond with the wear, the result being to restore the relation between the side bearings to their original condition. There are now 50,000 trucks in use with these bolsters, every one of which is tested before leaving the works, and we are told that the record is absolutely clear of failures up to date.

The question of weight sometimes urged against cast steel bolsters is answered by these people with the statement that there is no bolster so light for the capacity of these. In tests made on truck bolsters intended for cars of 60,000 pounds capacity a load of 100,000 pounds has been given in a hydraulic testing machine with a deflection of only 0.18 inch and no permanent set.

PERSONALS.

Mr. Henry Haynes, of Brenham, Tex., has been appointed Receiver of the Texas Western Railroad.

Mr. M. S. Curley has been appointed Master Mechanic of the Illinois Central shops, at Water Valley, Miss.

Mr. T. S. Tutwiler has been appointed Chief Engineer of the Plant system, with headquarters at Savannah, Ga.

Mr. J. H. Hawthorn, Master Mechanic of the Chicago & Erie, has resigned to enter the service of the Lehigh Valley.

Mr. Joseph J. Slocum, of New York, has been appointed Receiver of the Poughkeepsie & Eastern in dissolution proceedings.

Mr. G. E. Hustis has been appointed General Superintendent of the West Shore Railroad, to succeed Mr. C. W. Bradley, resigned.

Mr. A. J. Fox, of Detroit, Mich., has been chosen President of the Manistique & Northwestern, to succeed Mr. A. Weston, deceased.

Mr. Edward D. Seitz has been appointed Purchasing Agent of the Louisville, Evansville & St. Louis in place of Mr. W. W. Wentz, resigned.

Mr. Thomas Green has been appointed Acting Chief Engineer of the Minneapolis, St. Paul & Sault Ste. Marie Railway, to succeed Mr. W. W. Rich, resigned.

Mr. T. W. Hansell has been appointed Superintendent of Machinery of the Astoria & Columbia River Railroad, with headquarters at Astoria, Ore.

Mr. George H. Holt has resigned as Vice-President of the Indiana, Illinois & Iowa, and Mr. Joy Morton has been chosen to succeed him, with office in Chicago.

Mr. William Cotter has been appointed Superintendent of the western division of the Grand Trunk, with office at Detroit, to succeed Mr. A. B. Atwater, resigned.

John M. Marstella, Master Mechanic of the Baltimore & Ohio shops at Martinsburg, W. Va., died in that city June 25 from a stroke of paralysis. He was 57 years old.

Mr. F. O. Miller, Traveling Engineer of the Cincinnati, Hamilton & Dayton, at Ashland, Ky., has resigned to accept the position of Traveling Engineer of the Baldwin Locomotive Works.

Mr. George F. Evans, General Manager of the Canada works of the Westinghouse Air Brake Company, has sailed for Russia to establish a plant for making air brakes in St. Petersburg.

Mr. T. P. Shonts, who has been General Manager of the Indiana, Illinois & Iowa Railroad for twelve years, has been elected President of that road, to succeed Mr. F. M. Drake, resigned.

Mr. J. W. Campbell has resigned as General Manager of the Eastern Ohio Railway, and the office has been abolished and its duties assumed by Mr. W. H. Stevens, General Superintendent.

Mr. C. E. Lamb, Master Mechanic of the Hannibal & St. Joseph, has been appointed Master Mechanic of the Kansas City, St. Joseph & Council Bluffs, with headquarters at St. Joseph, Mo.

Mr. S. G. Simpson, General Freight and Passenger Agent of the Puget Sound & Gray's Harbor, has been chosen President of that road, to succeed Mr. J. A. Campbell. Headquarters, Seattle, Wash.

Rear Admiral Daniel Ammen, U. S. N., retired, died July 11. He was the designer of the ram "Katahdin" and was well known also for his efforts to interest people in the construction of the Nicaragua Canal.

Mr. C. F. Winn, who has been Joint Foreman of the Denver & Rio Grande and the Rio Grande Southern at Durango, Col., has been appointed Master Mechanic of the El Paso & North Eastern Railway, at El Paso, Tex.

Mr. P. J. Nichols, who recently resigned as General Superintendent of the Pacific division of the Union Pacific, has accepted the position of Superintendent of the Omaha Bridge & Terminal Company, at Omaha, Neb.

Mr. N. D. Miller has been appointed Chief Engineer of the Great Northern Railway, to succeed Mr. J. F. Stevens, resigned. Mr. Miller was formerly Chief Engineer of this line, but resigned in 1895 to engage in other enterprises.

Mr. George W. Stevens, formerly Purchasing Agent and Superintendent of Car Service of the Cincinnati, New Orleans & Texas Pacific, has been appointed Purchasing Agent of the Mobile & Ohio Railroad, with headquarters at Mobile, Ala., to succeed Mr. R. H. Duesberry, resigned.

Mr. H. S. Rearden, formerly Superintendent of the Chicago, Peoria & St. Louis, which position he resigned January 1 last, has been appointed General Superintendent of the Detroit, Toledo & Milwaukee, with headquarters at Toledo, Ohio, to succeed Mr. N. K. Elliott, resigned.

Mr. W. H. Caniff, who recently resigned as General Manager of the Lake Shore & Michigan Southern to accept the Presidency of the New York, Chicago & St. Louis, was on June 30 presented with a handsome gold watch and chain and a diamond stud by the employees of the former road as a token of the high regard in which he is held by them.

Mr. C. D. Ives, of Cedar Rapids, Iowa, a son of C. J. Ives, president of the Burlington, Cedar Rapids & Northern Ry., has reported to the War Department in answer to a summons from Secretary Alger. He will be appointed Captain and Commissary of Subsistence, and will be placed in charge of shipping all provisions and other commissary supplies to the army in the field.

Mr. A. G. Wand has been appointed General Agent for North America of the London & North Western Railway (England), Caledonia Railroad (Scotland) and Great Southern & Western Railroad (Ireland) to succeed C. A. Barattoni, deceased. Mr. Wand has been in the service of the London & North Western nearly twenty-five years, and was transferred to New York from the London office of the company when Mr. Barattoni was appointed in 1887.

Mr. Angus Brown, formerly Master Mechanic of the Northern Pacific at Livingston, has been appointed to succeed Mr. James MacNaughton as Superintendent of Motive Power of

the Wisconsin Central lines. Mr. Brown is succeeded by Mr. W. S. Clarkson, formerly Master Mechanic of the Rocky Mountain Division of the Northern Pacific, and Mr. J. P. Barnes, General Foreman of the Brainerd shops of the same road, has been promoted to Mr. Clarkson's position.

A communication from Shanghai says that an American named Captain Watson W. Rich, late Chief Engineer of the "Soo" Railway, and well known in the Lake Superior country, has been appointed Consulting Engineer of the Chinese Railway Administration, with headquarters at Shanghai. Captain Rich will be in charge of all railways building in China, under the immediate direction of Sheng Taien, Director-General of Railways. This appointment is likely to prove of considerable benefit to American manufacturers of railway supplies and equipment.

Mr. D. M. Philbin, General Superintendent of the Duluth, Superior & Western, has been made second Vice-President of the Eastern Railway of Minnesota, owing to the purchase of the former road by the latter. Mr. Philbin was formerly for three years General Manager of the Duluth, Missabe & Northern, and has been General Superintendent of the Duluth, Superior & Western since April, 1896. From 1890 to April, 1893, he was Superintendent of the Duluth, South Shore & Atlantic, and in 1889 was Superintendent of the eastern division of the Fremont, Elkhorn & Missouri Valley.

Mr. William Voss, well known as a master car builder and mechanical engineer, has lately accepted the position of Superintendent with the Jackson & Sharp Company, car builders, of Wilmington, Del. Mr. Voss is a graduate of a German technical school, and began on the Burlington, Cedar Rapids & Northern Railway, where he rose from the ranks to the head of the car department, and was afterward made Assistant Master Mechanic. He has held the position of Assistant Superintendent for Barney & Smith, of Dayton, O. Mr. Voss is well known to all railroad mechanical men through his book on "Railway Car Construction," which is the best book ever written on the subject.

Henry Flad, the well known civil engineer of St. Louis, Mo., died suddenly at Pittsburg, Pa., June 20. He was born in Bavaria, in July, 1824, and came to America in 1848. In 1854 he was appointed Resident Engineer of the Iron Mountain Road in Missouri, and had charge of the construction of a portion of that line. He also made surveys for several other roads in Missouri, and from 1867 to 1874 was the Chief Assistant of Colonel Eads in the construction of the great St. Louis Bridge. In 1877 he was chosen President of the Board of Public Improvements of St. Louis, which office he held until 1890, when he resigned to become a member of the Mississippi River Commission. He was at one time President of the American Society of Civil Engineers.

Mr. S. R. Callaway, President of the New York Central & Hudson River Railroad, writes us that Mr. H. J. Hayden, Second Vice-President, will hereafter represent the New York Central & Hudson River Railroad and its allied lines on the Board of Managers of the Joint Traffic Association. Mr. H. Walter Webb having resigned owing to ill health, the office is abolished. Mr. J. M. Toucey was appointed assistant to the President and the office of General Manager was discontinued, but he retired from service as noted elsewhere. Mr. Nathan Guilford, General Freight Traffic Manager, will have general supervision of all freight traffic and Mr. George H. Daniels, General Passenger Agent, of all passenger traffic, reporting direct to the President. The General Superintendent, Chief Engineer, Superintendent of Motive Power and Rolling Stock and the Purchasing Agent will hereafter report to the President direct.

HIGH STEAM PRESSURE VS. CAPACITY OF LOCOMOTIVES.

By William Forsyth.

Abstracts of the valuable report of the committee on "Efficiency of High Steam Pressure for Locomotives," presented at the recent convention of the Master Mechanics' Association, were printed on page 251 of our July issue, and we stated that one of the appendixes of the report, written by Mr. William Forsyth, Mechanical Engineer of the Chicago, Burlington & Quincy Railroad, entitled "Pressure vs. Capacity," would be given in full. This is the era of increased boiler power and the importance of increased capacity is now so clearly shown in records of heavy engines in service as to render Mr. Forsyth's presentation of the subject specially timely.

Pressure vs. Capacity.

It may be assumed that the efficiency of a locomotive may be increased either by increasing the pressure on the boiler or by increasing the size or capacity of the boiler. If the pressure is increased, the gain is to be found in the improved performance of the engines; if the pressures remain unchanged and the boiler is made larger its evaporative efficiency, when developing a given power, will be increased. Either an increase in pressure or an increase of capacity involves greater weight, and as the cost of a boiler of any given type will be approximately proportional to its weight, the whole question may be resolved into the following statement, namely: Shall any added weight which may be given the boiler of a locomotive be devoted to increasing its strength that a higher pressure may be carried, or to increasing its capacity that it may render its service while working at a correspondingly lower rate of power? The following paragraphs present some facts bearing on this question:

SHOWING CHANGE IN WEIGHT OF BOILER WITH STEAM PRESSURE.

Steam Pressure.	Weight of 60-inch Boiler.	Weight of 52-inch Boiler.
I.	II.	III.
140	..	21,035
150	33,121
180	35,253
210	38,513
240	39,035
250	25,775

Pressure and Weight of Boiler.—This table gives, in Column II., the weight of a 60-inch boiler suitable for a Mogul or ten-wheeled engine designed for different pressures varying from 150 to 240 pounds. The values given in this column are estimates supplied through the courtesy of the Baldwin Locomotive Works. Column III. of the same table gives weights of the boilers of the Purdue experimental locomotives, No. 1 and 2 respectively, which are in every way similar, except-

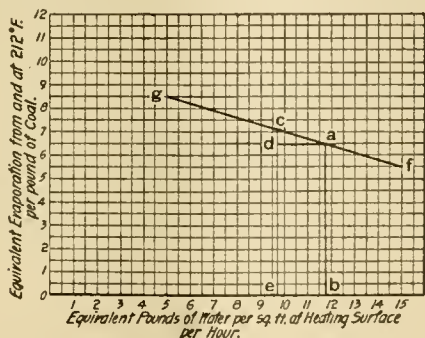

Fig. 4.—Reproduced from Report.

ing that one was designed for a pressure of 140 pounds and the other for a pressure of 250 pounds.

It will be seen that an increase in steam pressure from 150 to 240 pounds in a 60-inch boiler necessitates an increase in weight of 5,900 pounds, or 18 per cent., and that an increase in steam pressure from 140 to 250 pounds in a 52-inch boiler necessitates an increase in weight of 4,700 pounds, or of 22 per cent. It will, therefore, be sufficiently accurate for our purpose to assume that a change of pressure from 150 pounds to 240 pounds, an increase of 90 pounds, will neces-

sitate an increase in weight of boiler of about 20 per cent. The benefit to be derived from such an increase of pressure may be judged by reference to other portions of this report. We may next inquire as to the probable effect of converting the 20 per cent. increase in weight into increase in capacity.

Efficiency and Capacity.—The evaporative efficiency of a boiler depends on the rate of power to which the boiler is worked. The relation of efficiency and power, as defined by a large number of tests made upon the boiler of "Schenectady No. 1" at Purdue is shown by the accompanying diagram. It will be seen that when the power is such as will require 5 pounds of water to be evaporated per foot of heating surface per hour, 8½ pounds are evaporated for each pound of coal burned; but when 15 pounds of water must be evaporated per foot of heating surface per hour, only 5½ pounds are evaporated per pound of coal. Strictly speaking, the relationships disclosed by Fig. 4 apply only to the boiler from which they were derived, but as all locomotive boilers of usual form may be expected to give a curve of the same general character, that which is presented may be employed as the basis of the following general illustration. Thus, suppose that the demand for steam upon what may be called a "normal" boiler is such as to require the boiler to work at the point a on the curve of efficiency. If, now, the same demand for steam is supplied by a boiler whose heating surface is greater than that of the normal boiler, the larger boiler will work at some point, c, higher on the curve of efficiency; the increase in efficiency will be represented by the ratio of c d to a b. An inspection of the figure will show that the value of the ratio depends upon the length of the line d a and upon the location along the efficiency curve of the initial point a. That is, the increase in efficiency depends, first, on the amount of increase of heating surface, and, second, on the rate of evaporation of the assumed normal boiler.

Numerical values, based on the assumption that increase in capacity will be proportional to increase of weight, are given in the following table:

SAVING IN FUEL BY USING A BOILER WHOSE CAPACITY IS GREATER THAN AN ASSUMED NORMAL BOILER.

Pounds of water required to be evaporated per square foot of heating surface per hour in a normal boiler.	Percentage saving in fuel by using a boiler whose capacity is greater than the normal boiler, by 5, 10, 15 and 20 per cent., respectively.			
	5 per cent.	10 per cent.	15 per cent.	20 per cent.
I.	II.	III.	IV.	V.
5	0.8	1.5	2.2	2.9
6	1.0	1.9	2.8	3.7
7	1.2	2.3	3.4	4.5
8	1.5	2.9	4.1	5.3
9	1.8	3.4	4.8	6.1
10	2.0	3.9	5.5	7.1
11	2.3	4.5	6.4	8.2
12	2.7	5.1	7.4	9.4
13	3.0	5.7	8.4	10.7
14	3.4	6.4	9.4	12.0
15	3.8	7.4	10.6	13.6

This table shows that the saving which results from increasing the capacity of a boiler is most marked at high power. Thus, an increase of 20 per cent. in the size of a boiler increases the evaporative efficiency only 2.9 per cent. under a development of power which would be supplied by the normal boiler, by an evaporation of 5 pounds of water per foot of heating surface per hour, but increases to 13.6 per cent. when the power is increased threefold.

It is perhaps fair to presume that the heating surface, or better, the steam-making capacity, of a boiler of any given type may, within limits, be proportional to its weight. The improvements in efficiency recorded in Column XV. of Table II. are such as may be expected to result from such an increase of size as would produce a 20 per cent. increase in weight, the boiler pressure remaining the same.

The table referred to as No. II. gave the following figures from tests upon the laboratory locomotive, "Schenectady No. 1":

Speed in Miles per Hour.	Boiler Pressure by Gage.	Steam per H. P. Hour.
35.00	98.4	28.8
35.30	131.7	26.3
35.20	143.3	24.9

These values compared favorably with the possible gain in efficiency to be derived from an increase of pressure alone, and while the gain from increased pressure must for the present remain a matter of some speculation and doubt, that which is to be had through increased capacity is both certain and fixed.

(Established 1832.)

AMERICAN ENGINEER

CAR BUILDER AND RAILROAD JOURNAL.

29TH YEAR.

67TH YEAR.

PUBLISHED MONTHLY

BY

R. M. VAN ARSDALE,

MORSE BUILDING.....NEW YORK

G. M. BASFORD, Editor.

AUGUST, 1898.

Subscription.—\$2.00 a year for the United States and Canada; \$2.50 a year to Foreign Countries embraced in the Universal Postal Union. Subscriptions for this paper will be received and copies kept for sale by the Post Office News Co., 217 Dearborn Street, Chicago, Ill.

EDITORIAL ANNOUNCEMENTS.

Advertisements.—Nothing will be inserted in this journal for pay, EXCEPT IN THE ADVERTISING PAGES. The reading pages will contain only such matter as we consider of interest to our readers.

Special Notice.—As the AMERICAN ENGINEER, CAR BUILDER AND RAILROAD JOURNAL is printed and ready for mailing on the last day of the month, correspondence, advertisements, etc., intended for insertion must be received not later than the 20th day of each month.

Contributions.—Articles relating to railway rolling stock construction and management and kindred topics, by those who are practically acquainted with these subjects, are specially desired. Also early notices of official changes, and additions of new equipment for the road or the shop, by purchase or construction.

To Subscribers.—The AMERICAN ENGINEER, CAR BUILDER AND RAILROAD JOURNAL is mailed regularly to every subscriber each month. Any subscriber who fails to receive his paper ought at once to notify the postmaster at the office of delivery, and in case the paper is not then obtained this office should be notified, so that the missing paper may be supplied. When a subscriber changes his address he ought to notify this office at once, so that the paper may be sent to the proper destination.

The paper may be obtained and subscriptions for it sent to the following agencies: Chicago, Post Office News Co., 217 Dearborn Street. London, Eng., Sampson Low, Marston & Co., Limited St. Dunstan's House, Fetter Lane, E. C.

The question of stenciling the light weights of cars was taken up at the Convention of the Master Car Builders' Association, the increasing practice of loading locomotives on a tonnage basis being the reason for agitating the subject at this time. The matter has been considered by the Executive Committee of the association, and all car owners are requested to stencil these weights upon all cars and they are also asked to correct it when occasion requires, in order to facilitate economical operation. This is important, and railroad officers will at once see its effect in making it possible to give locomotives their proper loads. Other car owners will doubtless need some urging in order to bring them to view the matter in the light of a business item, from which they will benefit beyond comparison with the cost of the work. If private car owners do not act promptly the roads will save themselves trouble by doing the work, even at their own expense.

Reliable information with regard to the relative merits of different paints is very difficult to get and records of comparative tests are always subject to a great deal of criticism, because of the necessity for the existence of the "personal equation" in the comparisons, and also because of the great difficulties of securing conditions that are fair to all concerned.

We print in this issue a report on a comparison recently made in New York City which while not above criticism in regard to the length of time of exposure has the important recommendation of disinterestedness which is not always present in such cases. A longer trial of the paints might change the relative positions of some of them in regard to rust preventing qualities, but we do not believe that longer trials would alter the position of the carbon paints at the head of the list. In such trials red lead appears at a disadvantage because no one appears to be financially interested in these paints to such an extent as to give them the same care that the other patented or special paints receive. If the tests quoted are not to be accepted as final, and we do not think they ought to be, they are valuable as a step in advance which indicates the desirability of following the work up to a satisfactory and conclusive finish. Probably the only way to accomplish this is to place the subject in the hands of a carefully selected committee of the American Society of Civil Engineers. The value of accurate knowledge of the commercial value of paint for protecting iron structures is so great as to necessitate further work in this direction and the opportunity for the best kind of information to be obtained under the severest conditions of service is at hand.

GOVERNMENT TIMBER TESTS.

The tests on timber conducted in 1897 by the United States Department of Agriculture, the conclusions from which are given elsewhere in this issue, are important in practical results, which throw light upon several hitherto disputed points.

They show how great a degree of uniformity may be expected in strength of timber and indicate that differences of less than 10 per cent. in testing conifers and 15 per cent. with hard woods are to be expected in timber of the same kind.

As regards the influence of the size of the specimens, it appears that a marked increase in strength was found only when the length of the specimen was shorter than its width or, in other words, when the piece was shorter than a cube. Another important result was to show that the value of full sized specimens for test had been greatly over-estimated and the conclusions further indicate that it is not necessary to bother with a coefficient in obtaining the strength of large timbers based upon tests of small specimens within the limits already stated. The report makes this statement confidently and the effect will be to greatly simplify timber tests.

The tests on distribution of moisture show a comparatively uniform distribution along the stick in timber dried in yards, while a difference of 2 per cent. of moisture was found in adjacent sections of kiln dried timber having an average of from 5 to 7 per cent. of moisture throughout, the ends of the sticks for about two inches back showing about 3 per cent. less moisture than other portions.

The report is commended to engineers and others who are concerned with the strength of timber as the most important addition to information on the subject. The value of these results directs attention anew to the desirability of furnishing means for continuing, to completion, the work of the department which is so valuable, so thorough and so practical.

THE NAVY AT SANTIAGO.

It is too early to draw all the important inferences with regard to warship construction from the recent destruction of the Spanish fleet off Santiago, but the report of the Board of Survey, after examining the condition of the four wrecked cruisers, points to several exceedingly important factors which, we are safe in saying, will exert a powerful influence on future designs. In addition to these, we shall briefly comment upon another feature of this fight which does not appear to be properly appreciated.

While the Spanish ships suffered severely from direct gun

fire, they suffered more from conflagration caused by the exploding of well placed shells, and this drove several of them ashore. Large amounts of wood in decks, partitions and furniture have already been deprecated, but after this example our Navy Department should see to it that they have a large amount of handsome woodwork from our own ships for sale at the close of the war.

With less woodwork there will be less danger from fire, and less damage if fire should break out, but there is every reason to guard the fire apparatus from damage from shots. At Santiago the fire mains of the "Maria Teresa" were placed above the protective deck and were broken by a shell before the fire broke out. The place for fire mains is behind armor, and it should not be necessary to wait for this tragedy in order to establish what is really an axiom, yet ships have been built very recently without this precaution. It is unlikely that wood can be avoided altogether, and if a non-combustible substitute is found the danger from fire may be entirely avoided. Until this object has been attained, however, the water pipes must be protected.

The "Vizcaya" was badly riddled by shot and shell, but her death blow was probably dealt by one of her own torpedoes, from which we learn the importance of using only submerged, if any, torpedo tubes, on cruisers and battleships. If these are below the protective deck and below the water line, they are as safe as they can be made. Because none of the large ships have been able to use their torpedoes, many have thought it useless to provide them for large vessels, but such a conclusion seems unnecessary. Also, the torpedo boat has not occupied a prominent part on either side, but we should say that the experience with these boats is merely inconclusive, except as regards the futility of torpedo-boat attacks by daylight.

The relative values of large and small calibre guns has long been a bone of contention, and the importance of the secondary rapid-fire batteries was most clearly illustrated at Santiago, where the rapidity of the fire from the small guns very soon drove the Spanish gunners from their positions. The absence of adequate protection of the secondary batteries on the Spanish vessels contributed largely to their loss by rendering the gun positions untenable. It is somewhat surprising that the big guns did not do more damage. The conditions, however, were more favorable to the use of the secondary batteries, and, had it not been a "running" fight, the 12 and 13-inch guns would have taken a larger share of the work. Only one of the large projectiles hit a Spanish ship, yet the accuracy and effectiveness of the smaller guns was wonderful. On the other hand, reports say that a 13-inch shell was placed in the fire room of one of the Spanish torpedo boat destroyers, which answers criticisms as to the accuracy of their fire. We are told that the "Cristobal Colon" was hit eight times by the rapid-fire projectiles, though she was protected somewhat by the other ships; the "Vizcaya" was hit 24 times, the "Infanta Maria Teresa" 33 times, and the "Almirante Oquendo" 66 times. Some of this was due to the rapidity of the fire.

Among the constructive features, high speed is seen to be of the greatest value, and this introduces the element of the condition of the mechanical appliances with which all war vessels are crowded. The battleship has risen in the estimation of naval authorities, which is largely due to the work of a department not yet mentioned.

The condition of the machinery of the American ships stood for much, and greatest credit should be given the engineers' department for the way the vessels got into action without any warning whatever. Battleships are not expected to catch cruisers, yet the capture of the "Colon" was undoubtedly due to the splendid work of the engineers of the "Oregon." This, and the wonderful trip of this ship from Mare Island to Jupiter Inlet, and her captain's report that she was ready for action on arrival, should everlastingly set at rest all question of who should govern in the engine rooms of our naval vessels. The engineer is not, and never has been, a "non-combatant," but

rather a fighter of the first importance. Ships with guns ever so well handled, and armor and armament perfect, would yet be helpless with weakness in the engine room. All honor and credit to the gunners for their superb marksmanship; their work is so clearly seen in the holes they make that there is little danger of their being unappreciated, but it must not be forgotten that long, patient, preparatory toil by the engineers, and most heroic devotion by those below the water line in the lights, make it possible for the gunners to land their shots.

Some time we shall know the story of the Santiago fight from the engine room and the fire room, and it will equal, if not surpass, those already told from the turret and the deck. This is an engineers' war, and nowhere is the superiority of our ships more clear than in their mechanical departments. We have had good guns and superior shooting in other wars, but we never had such ships, such engines or such engineers before.

When the naval personnel question comes up again for final settlement, these things should be remembered, for guns and armor marksmanship and seamanship depend at last upon the engineer.

Summarizing, we should say: Gun practice should be encouraged; efficiency of secondary batteries should be the best to be had; the men should be protected at the rapid-fire guns; unnecessary fuel for conflagration should be avoided; the vital apparatus of ships should be below the protective deck; torpedoes should be kept below the water line; possibilities for securing maximum speed should always be kept in mind; and, finally, the mechanical department should be provided with every facility and every encouragement for maximum efficiency. More will yet be learned, but, if it is well learned, this is enough for one war.

NOTES.

The Atchison, Topeka & Santa Fe has every engine on the system running under the pooling plan.

By taking old ties from the road to the shops and burning them under stationary boilers, the Atchison, Topeka & Santa Fe saves \$25,000 per year.

A 33-knot, 350-ton torpedo boat destroyer, the "Express," is now building for the English navy by Laird Brothers, at Birkenhead. Her engines are to indicate 9,250 horse-power.

The largest cargo of steel rails ever sent out of Baltimore was shipped on the British steamer "Knight Companion" June 28 to Vladivostok, Russia. It was valued at \$120,150.

The boilers of the British battleship "Albion," recently launched at Blackwall, will carry a pressure of 300 pounds per square inch, which will be reduced to 250 pounds at the engines. She will have 20 Belleville boilers fitted with special feed water heaters or economizers.

A simple way to increase the output of a driving wheel lathe was recently illustrated in the "American Machinist." It makes use of three small screw jacks, held in the slots of the face plate of the lathe and screwed out against the rim of the wheel just under the tire. The jacks serve to steady the work and reduce the time required for turning from 11½ to 5½ hours and reduces the cost from \$3.25 to \$1.75 per tire. The feed was increased from 1-16 inch to 7-32 inch, and the cut was also increased to correspond.

The light-house equipment in the charge of the United States Light House Establishment at the close of the year 1897 is stated in the report of that department, just issued, to be as follows:

Light-houses and beacon lights.....	1,116
Light-vessels in position.....	42
Light-vessels for relief.....	5
Electric lighted buoys in position.....	11

Gas lighted buoys in position.....	30
Fog signals operated by steam, caloric or oil engines.....	149
Fog signals operated by clockwork.....	206
Post lights.....	1,779
Day or unlighted beacons.....	424
Whistling buoys in position.....	71
Bell buoys in position.....	112
Other buoys in position.....	4,710

It is stated officially, says "Engineering," that an important amendment of the Patent Law of Austria will come into force in January next. Patents will be granted for fifteen years for industrial inventions, excluding articles of food, medicines, disinfectants, or chemical products not produced by a new technical process. Prior publication in another country will prevent a valid patent being obtained in Austria. The Patent Office has the power to grant compulsory licenses if the inventor declines to allow his invention to be used, but the onerous and unsatisfactory provisions as to working patents which at present exist in Austria will be practically done away with. Annual renewal fees will be charged on an ascending scale.

A very heavy train was hauled May 10 on the Chicago & Eastern Illinois by a single consolidation engine from Danville to Chicago. The total weight of the train, including engine and tender, was 6,510,000 pounds, divided as follows:

Locomotive, with tender.....	268,000
Cars, each 16½ tons.....	1,815,000
Coal, 40 tons in each car.....	4,400,000
Caboose.....	27,000

Total weight of train, pounds.....6,510,000

The train was made up at Danville of engine No. 129, 55 coal cars of 80,000 pounds capacity and a caboose, and was hauled to Chicago under an average running time of over twenty miles an hour. The line is by no means level, the heaviest of several long grades being 21 feet per mile.

The "Kaiser Friedrich," the running mate of the "Kaiser Wilhelm der Grosse," arrived at New York June 17 on what was intended to be a record-breaking trip, but, owing to trouble with her machinery, which had not been "broken in" at all before the trip, she made a slow run. The ship is 600 feet long over all, 64 feet in breadth and 41 feet in depth from the keel to the upper deck. Her displacement, loaded at 28 feet draught, is 17,000 tons. She has twin screws and 5 cylinder quadruple expansion engines, the high pressure 43 inches and first intermediate 64 inches being tandem and the low pressure 93 inches each, while the second intermediate is 92 inches in diameter. There are nine double-ended boilers and one set of three boilers was placed abaft the engines. This gives a shaft about 248 feet long. There are 183 men in the engineering staff.

New locomotive coaling stations having improved facilities have been erected at a number of points on the Northern Pacific Railway, where comparatively few locomotives are supplied, and they are so arranged as to be cared for by a man who may also look after water pumping. The stations have two coal pockets of 35 tons capacity each, while a track pit brings up the storage capacity to 100 tons. The coal is shoveled from the car into a conveyor driven by a 4½ horsepower gasoline engine, which will elevate one-half ton per minute and dump it into the bins. The bins are equipped with Mr. E. H. McHenry's dynamometer, which accurately weighs the coal in each pocket, and enables enginemen to know how much coal they receive. This is a very compact and convenient arrangement.

A chronograph for recording exceedingly small intervals of time, such as a millionth of a second or less, has been used to record autographically the compression by a blow of a cylindrical piece of copper. In one case a 33-pound weight fell 15 in. and produced a permanent compression of 0.1658 in. In a copper cylinder, the time consumed in producing the compression being 0.0030317 of a second. The machine produces by photogra-

phy a curve showing the progress of the compression. The chronograph consists of a rotating cylinder, with a surface velocity of about 100 ft. per second, on which is photographed a pencil of light, which is passed through a hole in the end of a rapidly vibrating tuning fork. The delicacy of this instrument is far greater than that of the ordinary tuning fork chronograph, in which the record is made on a surface blackened by smoke.—[Engineering and Mining Journal.

Long distance runs are common on English railroads. The following table, reprinted from "The Mechanical Engineer," gives an idea of the long-distance running on the London & North-Western this summer:

	Miles.	Trains.
London—Crewe.....	158	5
Crewe—Carlisle.....	142	5
Carlisle—Crewe.....	142	5
Crewe—Willesden.....	153	6
Willesden—Stafford.....	128	1
Stafford—Willesden.....	128	1
Stoke—Willesden.....	140	1
Stafford—Holyhead.....	130	1
Crewe—Holyhead.....	106	1
Holyhead—Crewe.....	106	1
Northampton—Chester.....	116	1
Wigan—Carlisle.....	106	2

From this it will be seen that thirty trains are booked to run over 100 miles without a stop. In nearly all cases the speed is fifty miles an hour and over.

It is estimated that labor in the railroad industry absorbs from 60 to 70 per cent. of the money spent for operating expenses. On some roads it will be less, owing to traffic being lighter. In some departments, moreover, it takes a much larger percentage than others. Here are some figures from the last report of the Chicago & Northwestern, which serve as an example as to the respective cost of labor and material in each department:

	Labor.	Material.
Maintenance of way.....	\$2,873,032.36	\$1,269,985.03
Maintenance of equipment.....	1,335,184.42	1,098,003.58
Conducting transportation.....	7,214,017.32	3,757,453.90
General expenses.....	448,573.55	250,839.09
Totals.....	\$11,900,807.65	\$6,976,281.60

When expenses have to be reduced the great bulk of the reduction must fall upon the labor and not the material account.—New York "Commercial."

Very satisfactory cement for leather belting has been manufactured by kneading ten parts of carbon bisulphide and one part of oil of turpentine with guttapercha until a thick paste is the result. The portions of the leather where the cement is to be applied are to be unrolled and roughened, the cement put on, and the ends pressed together until the binding agent has become dry. Good caoutchouc cements, too, for rubber strips or rubber goods on metal are obtainable by dissolving shellac in ten times its weight of ammonia, and, after standing for three to four weeks, a transparent putty results, which is used without heating. The cemented places soften at first, but become hard and firm after evaporation of the ammonia, which may be assisted by heating. This cement is water-tight and gasproof, and is efficient for hard rubber articles—a mixture of guttapercha and asphalt being also serviceable in the same line.—"Engineering and Mining Journal."

A notable engineering feat was consummated recently at Bismarck, N. D. The east pier of the Northern Pacific Railway bridge, which spans the Missouri River at that point and weighs over 9,000,000 pounds, was moved from its foundation and slid on steel rollers a distance of nearly 4 feet to the new foundation. Preparations for this event had occupied a period of eight months, but the great event itself required less than a minute of time. Within sixty seconds a solid mass of granite weighing, with its pier and span, over 4,700 tons, was slid forward and rested upon the new foundation. The moving of the pier was necessary from the fact that it was displaced by the sliding of earth beneath the foundation several

years ago, and to correct the difficulty permanently it was decided to build a new foundation and move it back to the place from which it had slipped. The plans for the work, which is entirely unique in engineering, were prepared under the direction of Chief Engineer E. H. McHenry, of the Northern Pacific Road, and the work has been carried forward without interruption of traffic.

Staybolt failures to a sufficient number to cause boiler explosions are not confined to this country, as is shown by Sir Francis Marindin's report just submitted to the English Board of Trade upon the collapse of a locomotive firebox on the Belfast & Northern Counties Railway a year ago. The engine was built in 1890, and was thoroughly overhauled about four months prior to the accident. The firebox was of copper and the boiler, when it left the shops, was in good condition, safe for service. The accident occurred while the train was approaching a station at a speed of about 25 miles per hour. The inspector found that the engine had for some time been running with a number of broken and flawed stays on the right side of the firebox, and he believed that the number of these defective stays gradually increased until the point was reached when, owing to insufficient support, the plate suddenly collapsed. Sir Francis Marindin says that the only way to guard against such accidents is to have frequent examinations, more worthy of the name than those hitherto relied upon, and he reports that on the Belfast & Northern Counties line the boiler examiner is now required to make a proper examination of all boilers once a week.

The steaming radius of our naval vessels has been a subject of interest, and is clearly one of great importance in naval warfare. It is clear that speed and coal carrying capacity may determine success or defeat, steam colliers being at best but a very unsatisfactory, though necessary, adjunct to a naval formation. The comparative coal capacities of our principal ships has been formulated by the bureau of steam engineering as follows:

Ship.	Type.	Coal bunker capacity	Steaming radius on this coal at most economic rate.	Steaming radius on this coal at maximum speed with forced draft.
Iowa.....	First-class battleship	Tons. 1,730	Knots. a6,000	Knots. b2,355
Indiana.....	" "	1,550	4,805	b2,671
Massachusetts.....	" "	1,560	4,797	b2,265
Oregon.....	" "	1,540	5,205	c2,448
Brooklyn.....	Armored cruiser.	1,300	4,342	b1,404
New York.....	" "	1,200	4,486	b1,344
Columbia.....	Protected cruiser	1,600	a7,000	b1,840
Minneapolis.....	" "	1,420	6,824	b1,567
Olympia.....	" "	1,100	6,105	c1,408

a Estimated.
b From official trial, actual figures.
c From official trial on basis of 24 pounds of coal per indicated horse power.

The life of wooden piles used in bridges on the Chicago, Milwaukee & St. Paul Ry. was recorded by Mr. William Gannon at a recent meeting of the employees of the bridge and building department of that road as follows: "We use white oak, cedar, Norway, white pine and tamarack for piling in the pile bridges, the greater proportion being white oak. The thin bark, white oak piles from Wisconsin will last from 11 to 20 years; 20 years in wet clay soil and 11 years in sandy soil. The Southern oak piles are not as good as the Norway or pine piles; the sap, which is about three inches thick, decays in three years, and then worms and beetles go into the piles at the surface of the ground and work down from one foot to three feet, and in one or two years' time eat the piles entirely off if not disturbed or drowned by wet weather. By removing the dirt about two feet deep around the piles when

the worms first commence to work in them, and removing the sap rot, it disturbs the worms, and the remainder of the pile hardens and stops decaying and will last two or three years longer. The white cedar piles will last in sandy soil from 10 to 12 years, and in wet, clay soil from 22 to 30 years. They are brittle and do not hold spikes, and should not be used on curves or grades over eight feet to ten feet high. Piles of Norway pine, white pine and tamarack last from four to ten years, according to circumstances, and are not satisfactory for use in ordinary pile bridges. Hemlock, or cottonwood, for piles or timber should not be used in any bridge, as it decays in the center and shows fair and good on the outside. Water elm is not much better than hemlock.

CUSHIONED AND REVERSIBLE BRAKE BEAM STRUT.

The Monarch Brake Beam Company (Limited) of Detroit, Mich., exhibited a new reversible cushioned brake beam strut at the recent conventions at Saratoga, N. Y., where it attracted considerable attention among railroad men. Our engraving shows how it is made. The strut is so formed as to receive the fulcrum piece on pivots, which allow it to be reversed for use either as a right-hand or left-hand beam without requiring additional parts for such a change. The drawing shows the strut and fulcrum piece in section, making the construction and attachment clear. The cushion is inserted between the fulcrum piece and the seat in the body of the strut, the intention

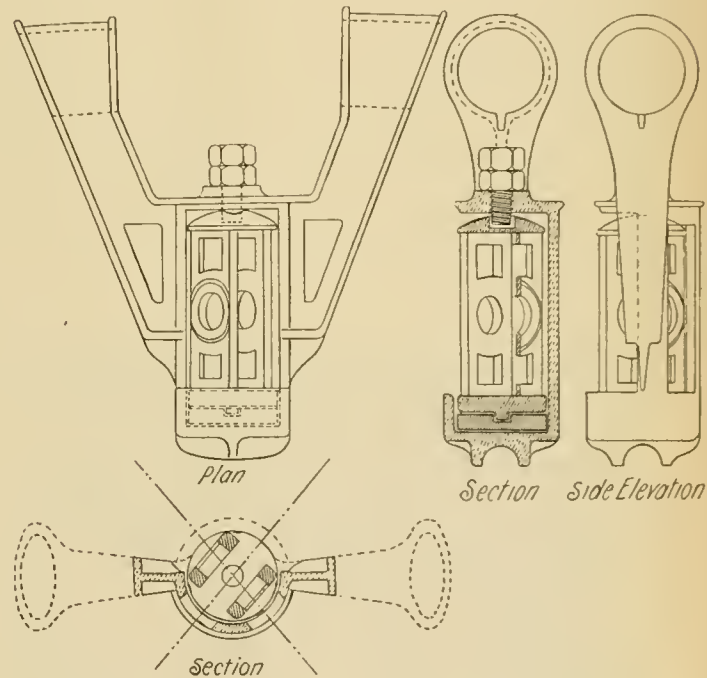

The Monarch Cushioned and Reversible Brake Beam Strut.

being to provide enough elasticity in the rubber block to prevent clattering of the brake shoes and sliding of the wheels. The rubber block is secured in a recess in the strut and the strut is rigidly attached to the brake beam. The form of this strut is such as to permit its use with the solid beam manufactured by this company. Since exhibiting the strut at Saratoga the company has taken a number of orders to equip passenger cars with it. It is the invention of Mr. Thomas E. Carliss, Superintendent of the Monarch Brake Beam Company (Ltd.).

The "Railway Age" deserved the thanks of the conventions for the "Daily" published at Saratoga this year. It was better than ever.

THE JOHNSON HOPPER DOOR.

Our three engravings show a new type of fastening for the hopper doors of coal and ore cars which after critical examination leads to the conclusion that it will work satisfactorily and fulfill the severe requirements of such fastenings. Hopper doors must be safe against accidental opening, they must be tight and the mechanism must be simple in order to be easily operated and economically maintained; also the devices must be self contained, not requiring levers or wrenches, and the mechanism must be sufficiently strong to resist strains from

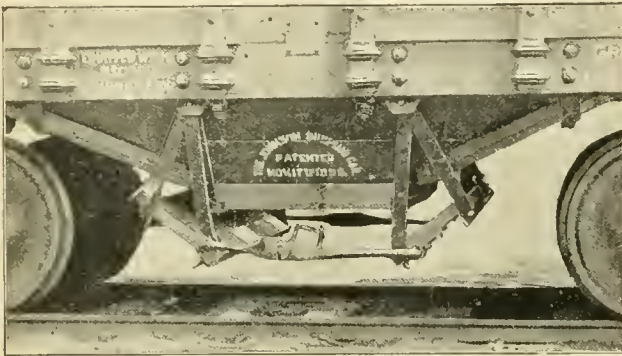

Fig. 1.

material clogging the doors or from freezing. These requisites all appear to be provided for in this door, with the further recommendation that the parts are not liable to damage when doors are left open on the road.

Instead of being hinged to the hopper these doors are swung from it by straps, shown in the engravings, the pivots being the hopper irons, and the effect of its construction is to bind the doors and the hopper together, insuring tightness when closed. The doors are not different from those used with hinged connections to the hopper direct.

The two doors are connected by a pair of toggle levers of different lengths. The shorter of these two arms is fastened to its door by a bracket. The longer arm is bent into a shaft

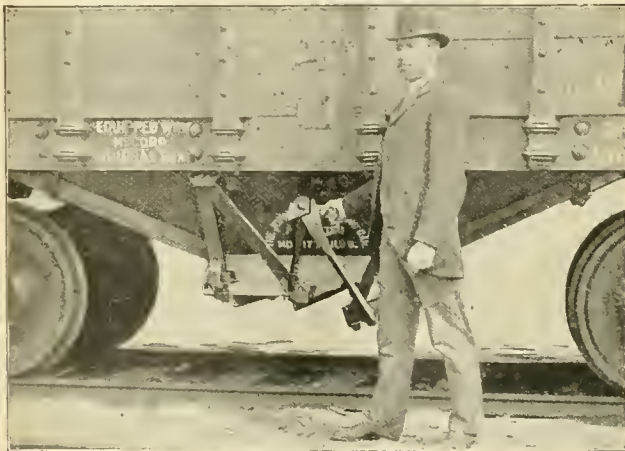

Fig. 2.

running across the bottom of its door to the other side and is bent around again to form the longer arm on the other side of the hopper. The arrangement of each side being the same it is possible to open or close the doors from either side. The operation is shown in the three views given. Fig. 1 shows the doors in the open position. In order to close them the operator grasps the hand-hold and lifts it to the position shown in Fig. 2. From that point he pushes the toggles in front of him, folding the two levers upon one another and laying them down upon a bracket placed upon the outer edge of left hand side of the hopper. In folding the toggles he has rotated the levers

until the line of the longer lever has passed the dead center of the pivot of the shorter lever. When the load comes upon the doors there is then a compression strain on the shorter lever and a tensile strain on the longer, the two forces counteracting one another and preventing any movement of the doors. The natural tendency would be to rotate the two still further down, but the bracket prevents this. No motion of the doors is possible without raising the two levers above the dead center mentioned. The operation in opening is the reverse of the one described. The operator raises the two levers above the dead center and the load swings the doors downward and backward out of the way.

The experience of 16 months' service has satisfied McCord & Company, of 100 Broadway, New York, and Old Colony Building, Chicago, who control the device, that it will substantiate all claims made for it, and they are strong ones. We reproduce some of these as follows:

It locks automatically and when locked, owing to its positive fastening, the door is held tight against the bottom of the hopper, and sagging down is impossible.

All of its attachments and fastenings are outside of the hopper, and when open, outside of the path of the load, removing any danger of damage from the load in passing out.

These attachments being outside of the hopper makes it easy to open or close the door in all kinds of weather. In fact, a

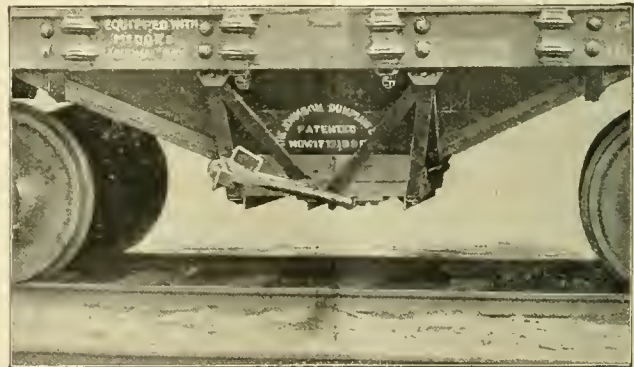

Fig. 3.

large leverage is secured to release the doors in case they should be frozen against the bottom of the load.

In opening, the doors do not approach much nearer the track than in the closed position and are therefore not apt to be damaged if left open.

As the doors do not swing down toward the track, the width of the hopper opening is not limited by this distance, and if necessary a much wider opening can be secured.

It may be applied to the ordinary style of hopper and does not require any change in the construction of the car.

FIREROOMS IN THE TROPICS.

Writing from Key West, June 13, a "New York Press" correspondent says: "An engine room and a stokehold on our war vessels are not, even in high latitudes, places where one would seek to cool a fevered brow, but in the tropics they become counterparts of pits infernal. Some of the more pessimistic officers of the navy are afraid that if the war is drawn out long the firemen of the fleet will be unable to stand the strain, and that when the break comes they will go by the dozens. So far they have stood it well. But they have suffered much, and the heroism of cleaning a fire in the bowels of a blistering warship on the Caribbean Sea is of the hourly and every-day kind that receives neither reward nor glory. Frequently when the 'New York Press' dispatch boat, on which I have been, was cruising on the south side of Cuba, the thermometer in the cook's galley, a small deckhouse with doors open on either side, registered 135 degrees and would have registered more if the thermometer had been graduated higher. What must have been the heat in the fireroom? Almost naked skeletons of men, hoisted up to the deck to lie gasping until revived by outward applications of water and inward applications of stimulants, told us of the terrors of those superheated depths."

GUNN'S RUNNING BOARD BRACKET.

Several years ago Mr. Robert Gunn, foreman of car repairs, Erie Railroad, devised and patented the malleable iron running board bracket shown in the accompanying engraving and it has been adopted as a standard on that road, where it has been in successful use for four years, during which time there have been no cases of loose running boards. It was very strongly indorsed by Mr. A. E. Mitchell, Superintendent of Motive Power of the road, in one of the discussions before the Master Car Builders' Association, who stated that no other form of running board fastening had been applied to box and stocks cars of the Erie Railway since 1894. It is also used on all cars passing through the shops for general repairs when new roofs are required. With the ordinary wooden bracket running boards warp out of shape and by their springing the

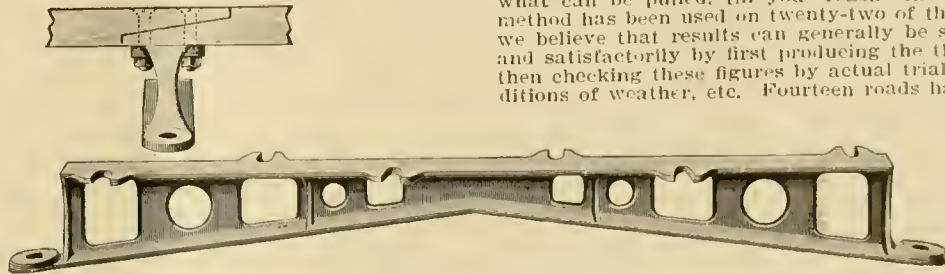

Malleable Iron Running Board Bracket.

nails are partly pulled out, causing brakemen to trip as well as rendering the roofs liable to blow off. Mr. Gunn presents the following claims for the device:

It provides a safe walk for trainmen, it tends to hold the roofs secure by preventing them from blowing off, it is of malleable iron and will last longer than the car and saves expensive repairs due to the frequent attention required for maintaining the ordinary running board fastenings.

The total length of this bracket is 2 ft. 2 1/4 in., its height at the ends is 2 7/8 in. and at the center 1 1/2 in. The device is made to strengthen the car roof by the passage of the bolts that secure the brackets to the car through the carlines as well as through the brackets. Three eighth-inch bolts are used for this, with nuts on each end. The holes for the bolts that hold the running boards to the brackets are slotted out as shown in the engraving. The holding down bolts have wings with flat surfaces 1 1/2 in. from the under sides of the upper nuts, to bear against the top faces of the roof strips so that the running board brackets may be removed without taking out the bolts. This construction helps to strengthen the roof. The device is a very simple affair but it is a good one and is important in that it tends to render this part of car construction more permanent than it otherwise would be.

The brackets are made by the Dayton Malleable Iron Company, of Dayton, Ohio.

The Bettendorf bolster of the Cloud Steel Truck Company was specified for 1,000 freight cars of 70,000 lbs. capacity, to be built for the Northern Pacific Railway by the Michigan Peninsular Car Company. These bolsters and also the Cloud steel trucks were also specified for 100 box cars, 50 stock cars and 25 coal cars, to be built for the St. Joseph & Grand Island R. R. by the Mt. Vernon Car & Manufacturing Co.

TONNAGE RATING FOR LOCOMOTIVES

The report on the subject of tonnage rating as submitted to the Master Mechanics' Association at the recent convention is given in abstract as follows:

In order to determine the value and success of the tonnage method of rating locomotives in comparison with other methods of making up trains, a circular was sent out, under date of October 5, 1897, asking for definite information on this point. Forty-three roads in the United States, Canada and Mexico, operating over 66,000 miles of track, reported that they were

using the tonnage method; some had been working this way for fifteen years, and some for only three months, with an average for all the roads of possibly two years, but the advantages derived were all of the same order, and may be comprehended, generally, by the following statement:

Heavier average trains hauled with less stalling; more uniform loads and better condition of engines, particularly the tubes, on account of not being overloaded; less engine and more car mileage; less friction between Motive Power and Transportation Departments, and more satisfactory results in every way.

Various estimates of the increase in trains handled under this method were given, which ranged from 10 per cent. to 43 per cent., but it is probable that the average will fall between 10 and 20 per cent. The figures, too, came from every variety of road, from the level and straight shore roads, and the undulating prairie roads, to the crooked mountain lines of the Appalachian and the Rocky ranges.

One of the first questions which arises when the desire to adopt the tonnage method of rating has aroused us is, how to obtain the proper rating for the different engines on the various portions of the road. The practical method naturally suggests itself first; that is, try it for each class of engine on each critical or controlling part of the division and keep on trying to see what can be pulled, till you reach the limit. While this method has been used on twenty-two of the lines reporting, yet we believe that results can generally be secured more quickly and satisfactorily by first producing the theoretical rating and then checking these figures by actual trials under various conditions of weather, etc. Fourteen roads have handled the sub-

ject in this way, while six have been content with a theoretical rating alone.

We have stated above that it is our opinion that the theoretical rating will be of great advantage in inaugurating tonnage rating, but to gain the greatest benefits from it it is necessary that it be fairly accurate in defining the work for different locomotives and localities. We will now attempt to show how the rating may be determined in advance of the trials, or even the completion of the road, provided the profile and alignment can be obtained. Mr. Tweedy, Chief Engineer, Wisconsin Central Lines, who has been much interested in the subject, says: "I am convinced that if some one would take sufficient time and pay enough attention to the matter, that it would not be very hard to get up a table that would be so accurate that every part of a road could be rated theoretically in the office from the track profile, and in such a manner that the results would be practically satisfactory."

We will enumerate the several factors which may be considered in producing the theoretical rating:

Power of the locomotive; adhesion of the locomotive; resistance of trains; value of momentum; effect of empty cars; effect of weather and seasons.

The starting point in all locomotive ratings is the power of the machine. The report of last year's Committee on Grate Area and Heating Surface, [See American Engineer, July, 1897, p. 251.—Editor], under the heading "Tractive Force," gave formulae for making these calculations, and Diagram No. 2 gave information regarding the mean effective pressure. It will possibly be more convenient for our present purposes to put this formula in a slightly different form. At slow speeds, say 50 to 75 revolutions per minute, with reverse lever in corner and a cut-off of 90 per cent. (which is common among freight engines), we may consider that:

Initial pressure..... = .95 boiler pressure
 Mean effective pressure..... = .91 initial pressure

Mean effective pressure..... = .86 boiler pressure
 Allowing 8 per cent. for friction..... = .92 M. E. P.

Mean available pressure..... = .80 boiler pressure

The value ".91" is obtained from Diagram No. 2 of the report above mentioned. Wellington (page 531) thinks 8 per cent. sufficient for internal friction. The result 80 per cent. boiler pressure agrees with figures assumed by the Baldwin Locomotive Works on page 87 of their new catalogue of narrow gauge locomotives, for working at slow speeds. The maximum speed at which these figures will apply is probably seven miles an hour for 50-inch wheels, eight miles an hour for 55-inch, and nine miles for 60-inch wheels.

From the mean available pressure, the tractive force may be computed by this formula:

$$\frac{p d^2 s}{D} = \text{Tractive force in pounds.}$$

Where p = Mean available pressure in pounds per square inch.
 d = Diameter of cylinder in inches.
 s = Stroke in inches.
 D = Diameter of driving wheels in inches.

This is clear of friction and represents the force exerted at the rails. Of course, the resistance of locomotive and tender must be deducted to get the net pull-back of tender.

We have stated above that the maximum tractive force could only be obtained at slow speeds—it is obvious that the boiler is totally insufficient to supply the quantity of steam for this force at high speeds. It will, therefore, be necessary to determine approximately the maximum tractive force at various speeds of which the engine is capable. If we assume that the grate area and heating surface have the values assigned by the committee last year, viz: three times the total cylinder volume for grate area, and 200 times for heating surface, in bituminous coal-burning engines, the units being square and cubic feet (page 230, M. M. Report for 1897), and the maximum rate of combustion to be 160 pounds per square foot grate area per hour, we should have (from Diagram No. 4 of previous report) an evaporation of six pounds water per pound of coal, from and at 212 degrees. This would give us:

$$3 V \times 160 \times 6 = 2,880 V = \text{pounds water evaporated per hour}$$

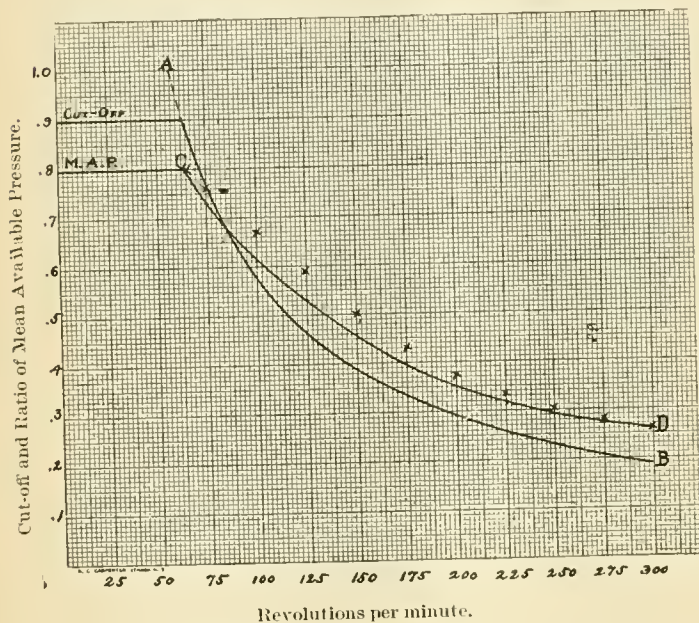

Diagram No. 2, 1898 Report.

from and at 212 degrees, where V = total cylinder volume in cubic feet.

From Formula 4 (page 227), by substituting X for cut-off and Y for revolutions, we have: $V \times X \times 2 \times Y \times .284 \times 1.2 \times 1.25 \times 60 = 2,880 V$ or

$$V \times X \times 2 \times Y \times .284 \times 1.2 \times 1.25 \times 60 = 2,880 V \text{ or}$$

$$X Y = \frac{2,880}{2 \times .284 \times 1.2 \times 1.25 \times 60} = 56.33,$$

which is the equation of an equilateral hyperbola.

Diagram No. 2 shows this line marked A—B, in which the ordinates give the cut-off and the abscissæ the revolutions per minute. This curve will be understood as showing the longest cut-off for which the boiler will furnish steam at the various speeds.

By means of Diagram No. 2 (last year's report), we can construct the line C—D, which shows the mean available pressure which may be expected at each speed.

The series of points X X, show the values assumed for this maximum pressure by the Schenectady Locomotive Works on page 222 of their catalogue of 1897, when the stroke is 24 inches. Of course, differences in proportions of locomotives and valve gears will vary the power somewhat.

The Master Mechanics' Committee in 1887 recommended for freight engines, $\frac{P d^2 s}{D} = .26 W$, P being the boiler pressure, or

$$\text{with a mean effective pressure of } .86 P = p, \frac{p d^2 s}{D} = .22 W,$$

where W = weight on drivers, or coefficient of friction taken at 22 per cent. (This is the figure adopted in last year's report.) Recently locomotives with pneumatic sanders have given satisfactory service where $\frac{P d^2 s}{D} = .31 W$, or for $p = .86 P$, $\frac{p d^2 s}{D} = .27 W$, or omitting effect of angularity of connecting rod and

considering $p = .80 P$, so as to include friction, we have $\frac{p d^2 s}{D} = .25 W$, or friction at 25 per cent.

Baldwin Locomotive Works Catalogue of 1897 (page 88), and Wellington's "Railway Location" (page 437), state that under favorable conditions 25 per cent. friction may be realized, but that in winter and under general conditions the friction may amount to only 20 to 22½ per cent.; we can, therefore, consider that the friction will be ordinarily 25 per cent. with good sanding

apparatus, and about 21 per cent. without such apparatus, so that $\frac{P d^2 s}{D}$ should be = or < .25 W or .21 W , respectively, where $p = .80$ per cent. of the boiler pressure in order not to slip the drivers at slow speed.

Diagram No. 1 [See American Engineer, June, 1898, Fig. 4, page 197.—Editor], reproduced from last year's report on Cylinder Volume, Grate Area, etc., gives the probable resistance of trains due to speed, grade, curvature and acceleration, and your committee sees no necessity for making any changes in this chart. A grade will generally have some curves upon it, and, if sharp, these may constitute a critical or stalling point for heavy trains. The allowance for curvature will, of course, give the power necessary to pass such points, but generally in calculating the load for a locomotive the curvature function may be omitted or reduced to a general average, as in passing through a curve a small loss of velocity will afford sufficient force to take the train around it. So, also, the average grade should generally be taken instead of the maximum, if the latter occurs in short stretches, where the same small loss in velocity would help the trains over. If there is to be much variation in the speed, the coefficient for this feature should be modified accordingly. Page 541 of Wellington's "Railway Location" gives some interesting tables on this subject.

While in mountainous regions, with long, heavy grades, there is little opportunity to take advantage of the force due to momentum, in undulating portions it may be utilized with the greatest advantage. A velocity of approach to a grade, when it can be reduced in ascending the grade, enables the engine to haul greater loads than it could without such assistance. This is well illustrated on the Norfolk division of the Norfolk & Western. The grade out of Petersburg, going east, is thirty-seven feet, and is about four miles long. As all trains stop at Petersburg, they are not able to get over the hill; the summit being passed, the helper returns. A few miles farther, the same grade exists—8,000 feet long—but at this point a preceding down grade enables them to obtain sufficient velocity to pull the train up with one engine that at Petersburg required two. This illustrates how stops, crossings, curves, water tanks, etc., will interfere with the make-up of a train, if so located as to prevent the use of momentum, and it is necessary to bear all these points in mind when figuring the rating for an undulating division. Many railway officers contend that the gain from momentum cannot be figured, and while it is difficult to arrive at very accurate figures, yet we think that a fair degree of success may be obtained by carefully considering the various factors in the case.

Effect of Empty Cars.—Wellington considers that the resistance per ton for empty cars varies from 30 to 40 per cent. more than that of loaded cars, on a level. Experiments on the Chicago, Burlington & Quincy showed about 50 per cent. more resistance on a level and about 7 per cent. more on a 30-foot grade. The location of loaded cars in a mixed train did not seem to materially affect the results.

Some recent experiments on level roads seemed to indicate that the resistance per car was nearly equal for empties and loads, but we do not believe that this would generally apply.

Sixteen roads reported making no allowance for empty cars. This may mean, in some cases, that the traffic is largely in one direction, and that there are not enough empties to load engines to their capacity when returning the cars. One road allows 8 per cent. excess, three roads, 10 per cent., two roads 25 per cent.; one road 5 tons, and one road assumes that they weigh 13 tons each. We also see allowances of 3 empties to 2 loads, 2 to 1, 5 to 2, 5 to 3, and 6 to 5.

Mr. McHenry, Chief Engineer of the Northern Pacific, has provided a triangular chart which covers empty, partly loaded and fully loaded cars, but each rate of grade requires a separate chart. Mr. Tracy Lyon, Master Mechanic of the Chicago Great Western, has formulated another, which requires a special line or locus for each class of engine. Both of these were recently illustrated in a paper read by Mr. L. R. Pomeroy before the New York Railroad Club, January 20, 1898. [See American Engineer, February, 1898, p. 65.—Editor.]

Mr. Lyon considers that the resistance per ton of an empty car is two pounds greater than a loaded car. If we take an increase of 30 per cent. for loaded cars on the level, we have 1.8 pounds at a speed of fifteen miles per hour, where the train resistance is six pounds, and this 1.8 pounds should be added to the regular resistance per ton. On grades, the effect will diminish in accordance with the formula:

$$e = \frac{1.8}{y_2 + 6}$$

Where e = the proportional increase in resistance of empty cars for the grade given, and y_2 = resistance due to grade in pounds per ton.

The weights of the empties merely to be increased by these amounts when making up the allowance for the engine. While this does not allow for partially loaded cars, it has the advantage that it is simple and can be easily applied. On momentum grades, the virtual grade should be used in selecting the value of e .

It occurs to your committee that the assignment of loads to engines by yardmasters, dispatchers and others would be greatly facilitated if each engine bore its class mark or letter on some conspicuous part, as, for instance, on the apron of cylinder immediately below the steam chest. This plan has been followed by the Norfolk & Western.

COMO, INTERNATIONAL ELECTRIC EXHIBITION, 1899

Como, the birthplace of Alexander Volta, is preparing to celebrate the centennial anniversary of the invention of the Voltaic battery. The exhibition will be an international one, open from May 15 to Oct. 15, 1899, and foreign electricians are invited to avail themselves of this opportunity for free discussion of the scientific and practical fields of electricity.

Como is a flourishing, industrious, commercial Italian city, situated on the main line of the St. Gothard Railway, about 40 kilometers from Milan. It is pleasantly situated at the foot of the Alps and on the shore of the most charming lake in Lombardy, to which it gives its name.

A special electrical exhibition in Italy is sure to be successful on account of the abundant hydraulic power available for electrical works. The application of this power to the manufacture of silk constitutes an interesting feature of Como, and rapid progress in this direction is now being made, although the city still remains indebted to foreign countries for its machinery and improvements. Foreign inventions will, therefore, be greatly appreciated at the exhibition, and they will be favorably placed among the exhibits. The city of Como, for encouragement, has offered a sum of 10,000 francs in prizes for new inventions.

Communications by mail should be addressed as follows: Comitato, Esecutivo per la Esposizione, Como, Italy.

The Receivers of the Baltimore and Ohio Railroad have turned their attention to the improvement of the grades on the Third Division, from Cumberland to Grafton, or, rather, that portion which lies between Altamont, the top of the 17-mile grade, and Terra Alta, where the Cranberry grade begins to descend. The line passes through Deer Park and Oakland, and crosses what is known as the "Glades" of the Alleghany Mountains. The grades are short and choppy, some of them being 80 to 85 feet to the mile. One of the first pieces of work to be done is now in progress at No. 58 Cut, where the grade is being reduced from 81 feet to 42½ feet per mile, with allowances for curvature. It is expected that the cutting down of this grade will permit of increasing the train load from 1,000 tons to 1,300 tons on east-bound trains. One mile of the roadway will be lowered, and it is expected that the work will be completed by the middle of October.

The bottom of the Pacific, between Hawaii and California, is said to be so level that a railroad could be laid for 500 miles without grading anywhere. This fact was discovered by the United States surveying vessel engaged in making soundings with a view of laying a cable.

The Walker Manufacturing Company, of Cleveland, has just received an order from Paris, France, for a large amount of electric railway equipment. It is substantially the equipment for 500 electric street cars, including 1,000 motors, 1,000 controllers and 500 trolleys. The value of the order is more than a half million dollars. This is another substantial tribute to American electrical machinery.

The Northern Pacific Railway has ordered 14 locomotives from the Schenectady Locomotive Works. Seven are to be 10-wheelers and seven heavy consolidations.

The number of railroad men discharged for excessive use of liquor during the past 22 years, according to Chief Arthur of the Brotherhood of Locomotive Engineers, has decreased from 20 to 1 per cent., and during the past 25 years the proportion of men owning their homes has increased tenfold.

A great achievement in modern railroad transportation has been accomplished near Pittsburg, where molten iron is being hauled a distance of five miles in tanks, from the furnaces to the rolling mills, the expense of a second melting being thus avoided.

Within the past month the first iron bridge erected in the State of Ohio has been removed. This bridge was over Salt Creek, on the Central Ohio division of the Baltimore & Ohio Railroad, in Muskingum County, and was built in 1851. It was a single span, 71 feet in length, and was known as a "Bollman deck truss bridge with plate girders." Bollman was at that time Chief Engineer of Construction of the Baltimore & Ohio Railroad.

BOOKS AND PAMPHLETS.

"A Treatise on the Locomotive Engine." By Maurice Demoulin. With an Introduction by Edouard Sauvage; 4 volumes, large octavo, 1,978 pages, 973 engravings and six plates. Paris: Baudry & Co., 15 Rue des Saint Peres, 1898. New York agents, Gustav E. Stechert, 9 E. 16th street. Price, 150 francs.

This book, in our opinion, is the most complete and best treatise on the locomotive ever published, and it is a pity that it is not in the English language. It is in four large octavo volumes with tables, plates and nearly 1,000 engravings. Up to date practice in the principal railroad countries of the world is recorded with observations upon the designs of the locomotives used and the reasons for the special lines of practice followed in each country. We shall not attempt to give a detailed outline of the work, because it could not be done in several pages.

Good sound practice is illustrated in general and in detail, and experimental work has no place in the book; it is devoted to the important questions of locomotive designs and operation. The arrangement is logical and convenient, and where it was possible the author gave credit to other publications for illustrations and information used. One of the characteristics of the work is the presentation of information in such form as to admit of comparison of the practice in different countries. The book is specially strong in its treatment of combustion and the disposition of fire-boxes and heating surfaces and in showing the disadvantages of forcing. This part of the subject occupies volume II. and in it the exhaustive tests of Henry, Baudry and Prof. Goss are specially referred to and different methods of designing fire-boxes and grates are shown. Interesting and valuable data are given in regard to the length of boiler tubes and the relative values of different forms of heating surfaces. The results of tests in stationary and locomotive practice are compared and a good idea of the thoroughness of the work is seen in the fact that 232 pages are devoted to boiler and fire-box designs. The materials for fire-boxes and boilers have their share of attention.

Cylinder action in the use of steam and condensation and other losses is treated very fully, including comparisons of different arrangements of cylinders. The author believes that the difficulties in making cranked axles strong enough to withstand the stresses of service as locomotives are made stronger and heavier will tend to increase the use of the outside connected type. Of the various types of compounds he prefers the four-cylinder plan, and believes it to be the one that will be most generally used in the future.

A great many examples are shown to illustrate designs and arrangements of the details of the running gear, and it is apparent that more attention is paid to cab fittings in Europe than in this country. It is also evident that foreign practice leads ours in regard to interchangeability. For example, five different classes of locomotives on the Great Eastern Railway of England use the same fire-box and boiler. Lubricants and lubrications are treated in an excellent chapter, and copies of specifications for American, English, French, German and Belgian engines are given.

The type, engravings, paper and binding are all in keeping with the high character of the work, and not the least interesting part is the introduction from the pen of Mr. Edouard Sauvage. The book undoubtedly will have a large sale, but it would have a much larger one if it had been written in English.

"Introductory Course in Mechanical Drawing," by J. C. Tracy, C. E., Instructor in the Sheffield Scientific School of Yale University, with a chapter in perspective by E. H. Lockwood, M. E., Instructor in the Sheffield Scientific School, New York and London. Harper & Bros. Cloth, 8 by 11 inches, pp. 100, with 163 illustrations and 8 plates. Price, \$2.00.

The author states in the preface that the book is intended for beginners and is to prepare the student for more extended

courses in any of the special lines of drafting. The endeavor has been made to make it comprehensive enough for use in schools and colleges and at the same time to have it meet the needs of the student who must work without the help of a teacher. The first three chapters are preparatory, dealing with instruments and the preparation for work. These are followed by three chapters on isometric, cabinet and orthographic projections. The next subject is perspective, and the closing chapter takes up working drawings. We should say that the author has carried out his plan most admirably and he has certainly succeeded in presenting the subject in a simple and clear way, discussing principles and leaving the application of them to difficult and advanced subjects to be worked out later. A student or apprentice may learn to draw by a careful use of this book, and we shall go farther than this and say that it offers a method which we believe to be superior to that in use in many of our technical schools. The courses have been well arranged and the time required on each is stated. The engravings are admirable and teachers will find much to interest them in the use that has been made of photographs from models. It is the best introductory work in drawing that has been published.

"The General Manager's Story." Old Time Reminiscences of Railroad in the United States by Herbert Elliott Hamblen. The Macmillan Co., 66 Fifth avenue, New York. 311 pages, illustrated, 1898. Price, \$1.50.

This is a book that will be finished by those who begin to read it. It is the story of the author's fifteen years' of experience as a railroad man in passing through various grades from freight yard switching to the office of general manager. It is an exciting, entertaining story, faithfully portraying railroad life and particularly that of train service. As a story it is weak in spots, and includes some exaggeration, but it is generally true to life. The author's knowledge of the operation of the locomotive is thorough and this is the strongest factor in the work.

We should say that very few men have gone through this long list of experiences which are said have really happened to the author, yet it is possible for as much to occur to a man, and we think of several such men who have been through it all. The book records the life, thought, characteristic language and strong self-reliant manhood of railroad men. The illustrations are excellent. They are so accurate in proportion and in spirit as to lead to the conclusion that the artist must have spent a long time in studying the subjects. They add greatly to the interest and appearance of the book. We have not space for all we would like to say of the book, but it is perhaps enough to say that those who read it will pass it over to some one else, with confidence that it will give pleasure and no disappointment. We do not know where to look for an account which so accurately presents the conditions which have given this country its remarkable railroad men.

"The Locomotive Link Motion." By F. A. Halsey, Associate Editor "American Machinist." 81 6x9 inch pages, with 46 illustrations. Locomotive Engineering, 256 Broadway, New York. 1898. Price, \$1.00.

This is an exceedingly valuable book. It is a study of locomotive link motion in which is developed the fact that there were two hitherto unsuspected errors in the motion due to the location of the eccentric rod pins back of the link arc and the angular vibrations of the eccentric rods, which errors combined with the one due to the connecting rods produce a final error which is corrected by locating the saddle back pin of the link arc, and the connecting rod, instead of being a disturbing factor, as has always been believed, is really a corrective one. The author contends that instead of being a faulty valve motion the Stephenson link motion is probably the best that can be found for locomotive work, and his study of the subject has been so thorough as

to make him an authority. The book places a series of articles which appeared last year in the "American Machinist" in convenient form somewhat elaborated and enlarged. The Bilgram diagram is used and the study of the subject resulted from an invitation from the Schenectady Locomotive Works to use their facilities for the preparation of a comprehensive account of present locomotive link motion practice. Mr. Halsey's "Slide Valve Gears," published several years ago by the D. Van Nostrand Co., is familiar to our readers, and the part of the present work devoted to plain slide valves is reproduced from that book. The practice of the Schenectady people in equalizing the lead, port opening and cut off for any point of stroke is indicated in a series of tables. The book is commended to all who have to do with link motions, especially as applied to locomotives.

"American Railway Bridges and Buildings, Official Reports of the Association of Railway Superintendents of Bridges and Buildings." Compiled and edited by Walter G. Berg, Principal Assistant Engineer Lehigh Valley Railroad, President Association of Railway Superintendents Bridges and Buildings. 706 pp., 250 illustrations, cloth, price \$2.50. Published by "The Roadmaster and Foreman," 91 South Jefferson street, Chicago, 1898.

This book presents the proceedings, reports and discussions of the Association of Bridge and Building Superintendents for the seven years of its existence, in concise and convenient form, much superior to that in which the reports originally appeared. The work of this organization is unique, and it is of great value to departments other than those in direct charge of the bridges and buildings. The publications of the association have been in limited editions, merely enough copies being printed to supply the members, and the compilation of the whole work of the organization renders it available for general use among trackmen and others who have to do with the subjects discussed. Mr. Berg has done a great deal of work in preparing the matter and it has been well done. It is indexed and provided with a table of contents. The desire to place the book in the hands of men of comparatively small means necessitated sacrificing something to price and for this reason we shall not criticize the paper and cuts, which would doubtless be better if low price was not an important object.

"Traité de la Construction, de la Conduite et de l'Entretien des Voitures Automobiles." Publié sous la Direction de Ch. Vigreux, Ingénieur Civil, Répétiteur à l'École Centrale des Arts et Manufactures. Par Ch. Milandre et R. P. Bouquet. Premier Volume, "Construction." Paris: E. Bernard et Cie., 53 Quai des Grands-Augustins. 4 francs. 1898. 300 pp., 156 figures.

This is the first of four illustrated volumes on the automobile carriage written in French and to be followed by treatment of steam, petroleum and electric carriages. The present volume presents the elements of construction of these carriages and illustrations cover the early work in this field as well as the details of present practice. The opening chapter is historical and the second presents general consideration, followed by chapters on resistance to traction, construction of wheels, brakes, transmission devices and the details of construction of other parts. The book is well arranged and will be valuable to those who are pursuing this subject, which is now in an interesting stage of development.

"Workingmen's Insurance," by William F. Willoughby, United States Department of Labor. Vol. XIV., in Crowell's Library of Economics and Politics. Published by Thomas Y. Crowell & Co., 46 East Fourteenth street, New York. 12mo; cloth, \$1.75.

This important work is devoted to the most painstaking and exhaustive examination of the problem of the insurance of workingmen against accidents, sickness and old age, that has yet been made. The author, Mr. William F. Willoughby, of the United States Department of Labor, has had exceptional opportunities for making this study. As an expert of that

department he has been repeatedly sent abroad on official investigations, during which he represented the United States Government at the International Congress, in relation to accidents to labor and social insurance, and other international labor assemblies. He was in this way brought into direct relations with officials connected with foreign insurance institutions, and was thus enabled to base his work entirely upon primary sources of information and personal investigation. His study includes an examination of the various systems of employes' relief departments organized by railway corporations in this country and Europe or by other large employers of labor, the insurance work of labor organizations in the United States and of friendly and other mutual aid societies. In carrying out this work, the author has aimed to make it one that not only would be of interest to students of social conditions, but would be of real value and assistance to those practically concerned with the management of insurance and relief institutions. The ways in which the present efforts of railway companies and labor organizations are defective, and the manner in which they should be improved, are clearly brought out. The book, therefore, appeals especially to the large number of officials connected with these bodies.

"Machinists and Engineers' Pocket Manual"—Laird & Lee, of Chicago, have just issued in their admirable collection of technical reference books a "Machinists and Engineers' Pocket Manual," edited by D. B. Dixon, a complete and compact work for reference by machinists and engineers. It includes a compilation of rules and solved problems pertaining to steam engines, steam boilers, steam pumps, etc., based on plain arithmetic, and free from algebraic difficulties, together with necessary tables and data of highly practical value in the machine shop, mechanical drawing room and steam power plant. It embraces a dictionary of terms used in steam engineering and electricity, the construction and operation of dynamos and motors, artificial refrigeration and ice making, treatise on the steam engine indicator, gearing, shafting, lathe screw cutting, etc., etc. It is an illustrated volume of 371 pages, printed on excellent paper and bound in leather, in pocket form, edited by a practical engineer for practical artisans and mechanics. Leather, with rubber band, and pocket; \$1.

"Monthly Summary of Finance and Commerce of the United States," April, 1898. Corrected to June 1, 1898. With two diagrams prepared in the Bureau of Statistics, Treasury Department. Mr. O. P. Austin, Chief of Bureau. Government Printing Office, Washington, 1898.

This summary is too well known to require extended notice at our hands. Its prompt appearance—copy received June 4, 1898—will be appreciated by those who have occasion to make use of the valuable tables.

"A General Freight and Passenger Post, a Practical Solution of the Railroad Problem," by James Lewis Coles. Third edition. G. P. Putnam's Sons, 27 West Twenty-third street, New York. 1898. Cloth, 312 pp., \$1.25.

This book suggests a system of operation of railroads similar to that of postal service, the rates being uniform regardless of the distance, and the application of this principle to be under control of the postoffice.

"Picturesque University of Wisconsin." Edited by W. H. Hibbs. Thirty-two pages, 11 by 15 inches; many illustrations.

This is a handsome, well illustrated and well printed folio of engravings from the "Daily Cardinal," the local students' publication at the University of Wisconsin. The location of the University Buildings is beautiful and this publication presents an excellent idea of the facilities for study, investigation and recreation. The equipment for engineering work is especially good.

"The Cost of Generation and Distribution of Electrical Energy," by Robert Hammond. Except "Journal of the Proceedings of the Institution of Electrical Engineers." Part 134, Vol. XXVII. Paper read March 24, 1898.

This is one of the most complete and exhaustive papers upon the subject of cost of power that we have seen. It compares the cost in detail, of the generation and distribution in a large number of cities and covers several years. The paper fills a pamphlet of 152 pages, and by means of tables and diagrams the author shows reasons for prophesying a very great reduction in the cost of electric power per unit.

Eighteenth Annual Report of the United States Geological Survey to the Secretary of the Interior, 1896-97. Charles D. Walcott, Director. In five parts, Part V. in two volumes. Mineral resources of the United States, 1896. Metallic products and coal. The same continued. Mineral resources, non-metallic products, except coal. David F. Day, Geologist, Chief of Division. Washington, Government Printing Office, 1897.

Commerce and Navigation of the United States for the Year Ending June 30, 1897. Vol. II, prepared in the Bureau of Statistics. Worthington C. Ford, Chief of Bureau. Washington, Government Printing Office, 1898.

"The Automotor and Horseless Vehicle Journal, a Record and Review of Applied Automot'ic Locomotion," is a monthly illustrated journal, devoted to automobile carriages and allied subjects. It is published at 62 St. Martin's Lane, Charing Cross, London. Price, 6d.

"The Foreign Commerce and Navigation of the United States for the Year Ending June 30, 1897." Vol. I, Treasury Department, Bureau of Statistics, Worthington C. Ford, Chief of Bureau. Government Printing Office.

"The Rose Technic," published at Terre Haute, Ind., is one of the brightest and best edited of the college magazines that we receive among our exchanges. The alumni show interest in it by contributing articles upon subjects connected with their practice.

"Annual Report of the State Board of Arbitration of Massachusetts," for the year ending December 31, 1897.

"Bulletin of the Engineering Department University of Vermont," State Agricultural College, Burlington, Vt., 1898.

"Railroad Commissioners' Report, Massachusetts," returns of 1897. Boston, January, 1898.

"Annual Report of the City Engineer of the City of Providence for the Year 1897." Otis F. Clapp, City Engineer.

"Eleventh Annual Report of the Interstate Commerce Commission, 1897." Washington, Government Printing Office.

"Report of the War Department, 1897, Chief of Engineers." Six volumes with plates and tables.

Register of the Lehigh University, South Bethlehem, Pa. 1897-1898.

PNEUMATIC TOOLS.—The rapidity of the progress which pneumatic tools have made in application to various kinds of work previously always done by hand is best appreciated by contrasting the handsome morocco bound catalogue of the Chicago Pneumatic Tool Company, now before us, with the modest representation of the Boyer pneumatic hammer with which this firm entered the field less than three years ago. Probably no business of this kind ever has had a more rapid growth, the explanation for which is that people want and must have these tools because of the saving effected by them in labor and quality of work. They have revolutionized railroad repair shop work as regards chipping, reaming, boiler flue beading and similar work, and the same statement applies with equal force to shipbuilding, an air compressor now being a necessity in every shop. These tools are making as good headway in Europe as in this country. The catalogue states that they are in use on 245 railroads in the United States and Canada, and on every prominent railroad in Europe, as well as in over 2,000 boiler shops and shipyards. Anything that stirs conservative Europe to this extent must be first class in every respect.

The tools illustrated in the catalogue are as follows: "Chicago" and Boyer breast drill, pneumatic riveter, pneumatic casting cleaner, Boyer speed recorder, piston air drill, flue roller, expander and cutter, flue welder and reducer, Manning sandpapering machine, air hoist and compressor and Chicago rotary drill.

The hammer when used for beading locomotive boiler flues will bead 250 in 100 minutes. Five sizes of hammers are furnished—Nos. 0, 1, 2, 3 and 4. No. 0 is used in connection with a "holder on" in riveting; No. 1 is for light riveting, chipping and calking; No. 2 is used for general purposes, as chipping and calking; No. 3 is for flue beading and general calking, and No. 4 for light chipping and calking. The hammer will do the work of four men when used for beading flues, calking or chipping boilers, or cutting off staybolts.

The catalogue publishes a number of letters received from

high officers in prominent shipbuilding firms, and among them is one from Mr. Sommers N. Smith, General Superintendent of the Newport News Shipbuilding & Dry Dock Company, in which he says of the hammers and drills: "They have been tested upon drilling, chipping, reaming and calking upon steel castings, protective deck plates, angles, hull plating, and armor plates; also, on boiler and machine work, and they have more than fulfilled our expectations." Similar letters from other firms are shown, among them from the Bigelow Company, New Haven; John Mohr & Sons, Chicago; the Globe Iron Works Company, Cleveland, and the Chicago Shipbuilding Company. Mr. Henry W. Cramp, Vice-President of the William Cramp & Sons Ship & Engine Building Company, says of these tools: "They have given entire satisfaction both as to efficiency and endurance and as to celerity of operation." Over 100 of these pneumatic tools have been supplied to this firm of shipbuilders.

The use of pneumatic hammers for riveting is new, and the results are surprising to those who see the work for the first time. The No. 1 hammer will drive rivets up to $\frac{5}{8}$ -inch diameter, and the No. 0 takes rivets up to $\frac{3}{4}$ -inch diameter.

The company has added a lot of new appliances to its list of productions during the past year, and we are told that there is great difficulty to keep the supply up to the demand. The company is sparing no expense or effort to improve its product, which keeps them far ahead of all competitors. Nearly all of the tools illustrated and described on pages 238 and 239 of our July issue, showing the exhibit at the recent convention at Saratoga, were sold on the spot. The flue cutter attracted more attention than any other exhibit at the convention.

The catalogue, with 32 fine engravings made from wash drawings, is a creditable piece of work. It is bound in leather, and is interesting as well as attractive. We shall give our readers complete descriptions of many of these interesting tools. The wonderful success of the company in this country and abroad is due to the energy, perseverance and business capacity of Mr. John W. Duntley, President.

The "Pall Mall Magazine" for July has an interesting article by Mr. Angus Sinclair, editor of "Locomotive Engineering," on the "Evolution of Comfort in Railway Traveling in America." The history and development of sleeping and parlor cars, the comforts of travel in this country, car lighting—in which the Pintsch system is stated to be the successful system of lighting in general use—and the development of dining cars, are all treated in a pleasant way. Of the development of car lighting he said:

"A great variety of oil lamps were tried, and some of them threw a very good light upon the roof, but they were a delusion to the person who tried to read by them. The line of progress was toward gas, and a great many systems of gas lighting were tried. None were satisfactory until the Pintsch gas was introduced. That system is now general in the United States, and is satisfactory. The cars are very well lighted, and the jets of gas run from 200 to 350 candle-power for each car. Electric lighting has been introduced on some railroads, but it does not increase in popularity."

The Phosphor-Bronze Smelting Co., Limited, of 2200 Washington avenue, Philadelphia, have just issued "Price List No. 13," dated June 1st, 1898. The list gives prices for roll and sheet phosphor-bronze, for the metal in wire coils, in telegraph and telephone wire, rods, cast bolts, nuts and washers, wire ropes, cords and rigging ropes, tiller ropes, nails, wood screws, sash chains, gunpowder mill tools and a variety of other phosphor-bronze products. Those having occasion to use this material in these forms and those using bearing metals, should procure a copy of this list. This firm manufactures the "Elephant Brand" phosphor-bronze and other alloys.

The Westinghouse Electric & Manufacturing Co. have printed a small eight-page pamphlet entitled, "Protection, Not in Fancy, but in Fact," calling the attention of street railway and central station managers to their line of lightning arresters and choke coils. Among them are the Wurts lightning arresters for alternating currents; non-arcing metal, double pole, sta-

tion arresters; high potential arresters for 15,000 volt currents used as transmission circuits; those for direct current circuits; for railway service and multiple spark gap choke coils for street-railway service.

"Proceedings of the Fifth Annual Convention of the Association of Railroad Air-Brake Men." Held at Baltimore April, 1898. The proceedings of this wide-awake and exceedingly useful organization contain reports and discussions of the convention, including subjects having to do with the construction, operation and maintenance of the air brake upon trains. The pamphlet is a valuable one and the information given is from the practical men who are directly concerned with the apparatus. As an appendix, Mr. R. A. Parke's paper on "The Effect of Brake Beam Hanging Upon Brake Efficiency" is added. Also a list of members and the constitution. The secretary is Mr. P. M. Kilroy, Pine Bluff, Ark.

"Graphite as a Lubricant." The Joseph Dixon Crucible Co. of Jersey City, N. J., have sent us a copy of the 1898 edition of their 34-page pamphlet, having a new cover and four pages of new matter. The use of graphite for lubricating gas engines is worthy of note, and we have already called attention to its employment for this purpose on the Pennsylvania Railroad. The pamphlet illustrates a hand oil pump for introducing graphite or oil into engine cylinders, putting it just where it is needed. The experience of engineers with graphite, which this pamphlet presents, is worthy of careful attention, and we understand that the pamphlet as well as samples of graphite will be sent to any one interested in better lubrication.

The Chicago Pneumatic Tool Company has issued a handsome special catalogue in pamphlet form, illustrating the exhibit of pneumatic tools at the Saratoga conventions of the Master Car Builders and Master Mechanics' associations. The tools shown in this pamphlet are those described on page 238 of our July issue, and examination of the engravings will give an excellent idea of the wide scope of this convenient, labor-saving machinery. The pamphlet, like all of the publications of this company, is in good taste, and the work is handsomely executed throughout.

Q. & C. Catalogue. A supplement to Catalogue C and D has been received from the Q & C Company, 700 Western Union Building, Chicago.

It illustrates and describes the Stanwood steel car step, self feeding rail drills, compound lever jacks, M. C. B. standard steel brake shoe keys, portable rail saws and power cold saws for frogs, crossings and switch work.

"Air Compressors, 1898." Catalogue No. 32. The Ingersoll-Sergeant Drill Co., 26 Cortlandt street, New York. There is little to be said about the product of this firm, its compressors are so well known to our readers. The present catalogue brings them up to date and presents a great deal of valuable information not published before. It describes and illustrates the air compressing product of these builders and is a complete and valuable compendium of their standard machinery. The paper, printing and engraving are excellent.

"Summer Resort Train Service," New York Central & Hudson River Railroad, is a four-page illustrated pamphlet containing statements of the train service to the Thousand Islands, Adirondack Mountains, Saratoga, Lake George, Lake Champlain, Niagara Falls, Richfield Springs, White Mountains and the Maine sea coast summer resorts. Four enticing half-tone engravings speak volumes for the enjoyment to be obtained at these famous summering places. The pamphlet was prepared by Mr. George H. Daniels, General Passenger Agent.

"New England Lakes" is the title of a pamphlet just issued by the passenger department of the Boston & Maine Railroad. It has but a single page of text accompanying a fascinating and alluring series of half-tone views of what are very properly called "Aqueous Brilliants of New England's Crown."

A Water Purifying Plant.

BY HOWARD STILLMAN.

[This paper was read at the December, 1897, meeting of the American Society of Mechanical Engineers, and we reprint it, in abstract, by request, as it has not appeared except in the proceedings of the society.]

About a year ago the Southern Pacific Railroad Company established at Port Los Angeles, Cal., a plant or adjunct to the pumping station for the purpose of purifying the water supply at that point of the large amount of scaling matter it contained.

The chemical principles involved are based on the well-known Clark or Porter-Clark process.

The method which we are to discuss is intended to do away with an elaborate system of works, and to furnish a continuous supply of purified water of constant quality without the use of agitators to assist chemical action, or the necessity for labor other than that in usual attendance at a water station.

The water at Port Los Angeles required a double treatment on account of the bi-carbonate of lime contained, together with a large amount of the sulphates of lime and magnesia.

ical tanks is kept at a desired pressure, just overbalancing the hydraulic pressure in the water main, and allowing the solution to flow through the $\frac{1}{2}$ -inch feed-pipe when the cocks *f* are open. These cocks are always operated wide open to prevent possible clogging up of the pipe by a casual obstruction, and the air pressure is allowed entirely to control the flow of solution to mingle with the water flowing through the circulating tanks to the reservoir. The pressure-regulating valves are controlled in the usual manner by wrench and screw at bottom, so that the operator can occasionally adjust the feed of solution. Each chemical tank is about four feet high, and provided with a long sight feed glass so that the contents can always be noted. They are ganged to feed out 11 inches per hour, and when pressures are adjusted do not ordinarily vary. Occasional attention to the pressure valve during pumping hours, such as an engineer gives his sight-feed lubricators to steam engine or pump, is sufficient, inasmuch as the hydraulic pressure during pumping hours does not vary more than the head varies in a gravity supply. It has been found that the air pressure on the chemical tanks is about an atmosphere less than hydraulic pressure in the main, so that, at would be expected, the pneumatic action is to hold back the solution from flowing out too fast. As referred to above, this feed could have been regulated from the cock *e*, or the pipe made smaller, but it was desired that at no time should the operation "hang fire" by clogging of a small opening. When the pumping ceases the cocks *e* in feed-pipes are immediately closed,

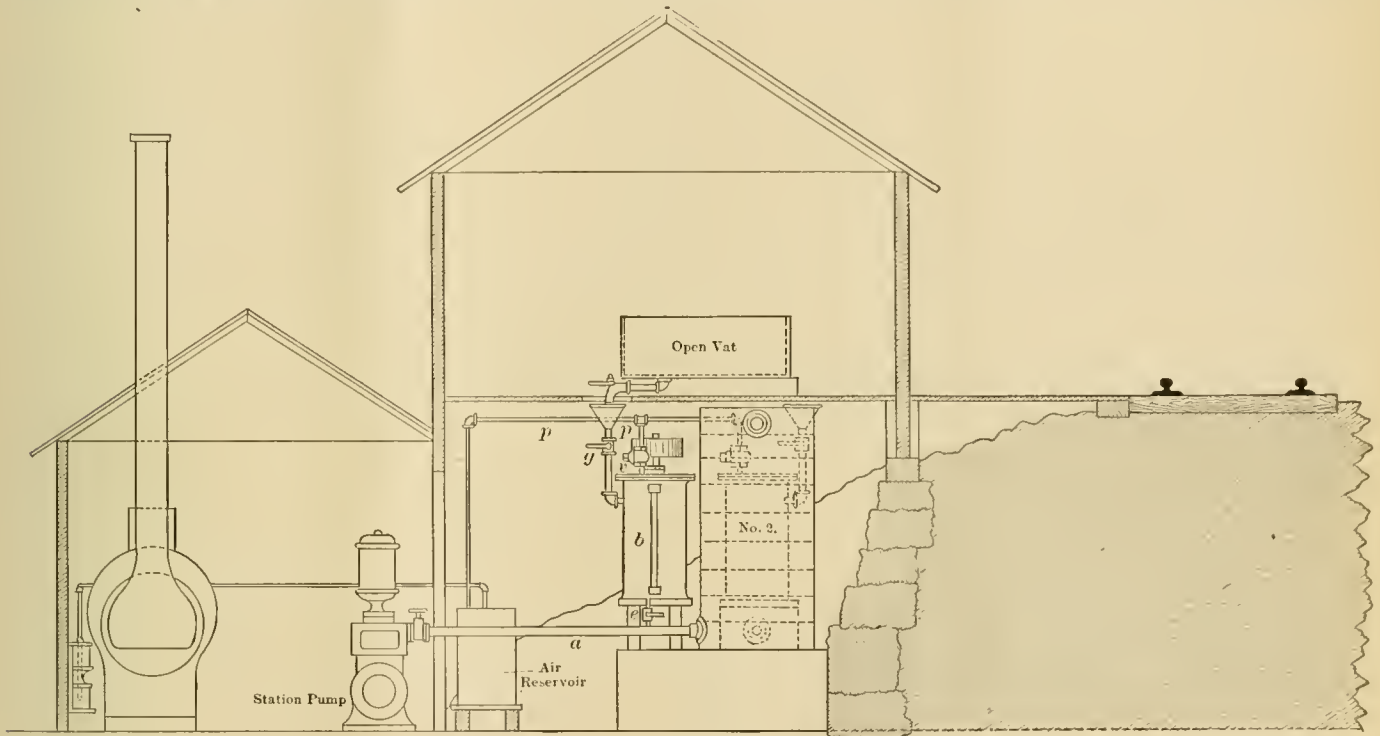

Fig. 1.

The general plan (Fig. 1) shows a section elevation and Fig. 5 a plan of the purifying addition and pumping station. As the system is independent of the action of the pump, except as a constant source of supply, that machine does not necessarily form part of our description. Referring to Fig. 1, the water main, *a*, is intercepted in its passage from the pump to supply tanks (Fig. 2) by the circulating tanks, Nos. 1 and 2 (Fig. 1). Detail of construction of these tanks is shown in Fig. 3. They are alike, each about $4\frac{1}{2}$ feet in diameter by 8 feet high, and the space inside is divided up by partial diaphragms, alternately placed, allowing the water in its course to circulate upward, under and over, and check its motion, allowing time for chemical action to take place within them.

Their size is such as to allow the water about five minutes in passing through, and the tanks serve virtually as an enlargement of the water main at that point; the arrangement of the diaphragm or baffle plates is not essential to the process, and the circulating tanks are not intended to deposit or dispose of sediment. The water main enters tank No. 1 at the bottom and discharges at the top, thence to bottom of No. 2, again discharging at top, and on to the supply and settling tank (Fig. 2).

Just before entering each of these circulating tanks the water main is tapped by a $\frac{1}{2}$ -inch pipe, conveying in a steady stream, when in operation, a solution of desired chemical reagent from the chemical tanks at *b*, *c*. These chemical tanks are shown in detail at Fig. 4, and the $\frac{1}{2}$ -inch feed-pipes leading from them, *e*, *e*, are controlled by the plug cocks *f*, *f*. These smaller tanks are also of like dimension, and hold 100 gallons when charged with solution, which suffices for four hours' continuous operation of the pump, or a supply of about 44,000 gallons of water. As shown in Fig. 4, the tanks are air-tight when all cocks are closed, and are filled through the $\frac{1}{4}$ -inch pipe and screened funnel when the cock *g* is open. The top is tapped by a $\frac{1}{2}$ -inch pipe leading from an air reservoir supplied with compressed air from an 8-inch Westinghouse pump. Just before entering the tanks the small air-pipe *p* is intercepted by a pressure-regulating valve, *v*, whereby the air pressure within the chem-

ical tanks is kept at a desired pressure, just overbalancing the hydraulic pressure in the water main, and allowing the solution to flow through the $\frac{1}{2}$ -inch feed-pipe when the cocks *f* are open. These cocks are always operated wide open to prevent possible clogging up of the pipe by a casual obstruction, and the air pressure is allowed entirely to control the flow of solution to mingle with the water flowing through the circulating tanks to the reservoir. The pressure-regulating valves are controlled in the usual manner by wrench and screw at bottom, so that the operator can occasionally adjust the feed of solution. Each chemical tank is about four feet high, and provided with a long sight feed glass so that the contents can always be noted. They are ganged to feed out 11 inches per hour, and when pressures are adjusted do not ordinarily vary. Occasional attention to the pressure valve during pumping hours, such as an engineer gives his sight-feed lubricators to steam engine or pump, is sufficient, inasmuch as the hydraulic pressure during pumping hours does not vary more than the head varies in a gravity supply. It has been found that the air pressure on the chemical tanks is about an atmosphere less than hydraulic pressure in the main, so that, at would be expected, the pneumatic action is to hold back the solution from flowing out too fast. As referred to above, this feed could have been regulated from the cock *e*, or the pipe made smaller, but it was desired that at no time should the operation "hang fire" by clogging of a small opening. When the pumping ceases the cocks *e* in feed-pipes are immediately closed,

and when again pumping is renewed the cocks are opened. At Port Los Angeles the hydraulic pressure is about 92 pounds gauge, and the discharge of the pump a little over 11,000 gallons an hour. The chemical tanks are filled as required from the mixing vats, on the floor directly overhead, which is on a level with the track, as shown in Fig. 1. These vats are open and have $\frac{1}{4}$ -inch pipe connection at bottom, terminating in plug cocks opening downward through holes in the floor directly into the screened chemical tank funnels, for convenience in filling. The vats are rectangular in form and of such size that a 12-inch depth of liquid fills a chemical tank for four hours' continuous run of pump. The weight of chemical material per 12-inch depth of liquid in the open vat gives a standard solution and is based on the quality of the water and its hourly rate of flow through the main to the reservoir, which data give the key to the situation; as, for instance, supposing analysis and tests of the water show that it will require $1\frac{1}{2}\%$ pounds of un-slacked lime to absorb the carbonic acid in 1,000 gallons. The flow through the main being 11,000 gallons per hour and the charge to last four hours, then we have 4 by 11 by $1\frac{1}{2}\%$, or 72 pounds of lime to be slacked with water to a depth of 12 inches (100 gallons) in the mixing vat. When slacked and mixed the liquid is a cream of lime, which is run off into the chemical tank when desired, as before stated.

It requires about five minutes' time to refill the chemical tanks and recharge with air, at which time the water supply or pump is stopped.

The tank charged with cream of lime is provided with an upright revolving shaft carrying paddles, as shown in Fig. 4, and works through a stuffing box in the top by means of a small air motor. The paddles revolve slowly when the tank is feeding into the main, and their purpose serves to stir up the milk of lime to prevent it settling out, and thus deliver a constant amount of lime to the water being treated.

We have just considered the operation of introducing quick-

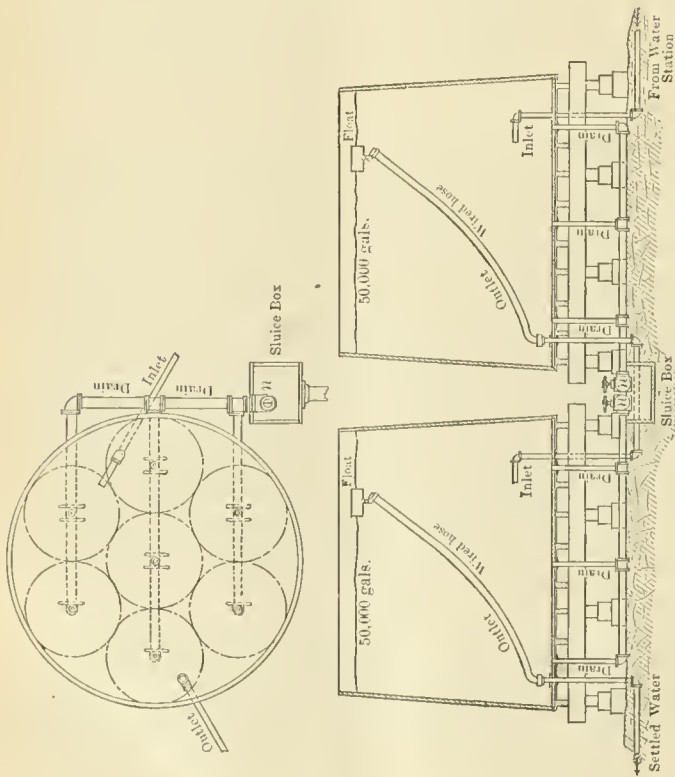

Fig. 2.

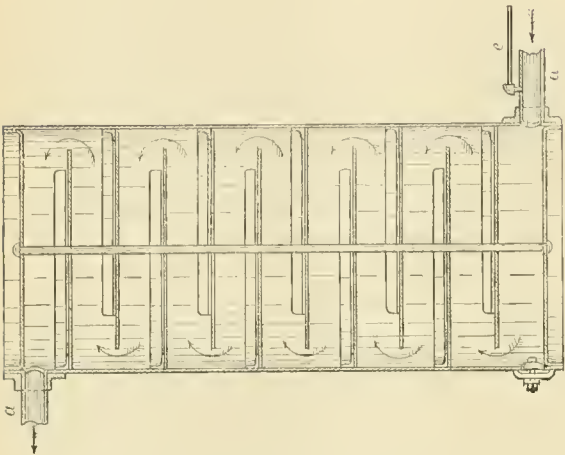

Fig. 3.

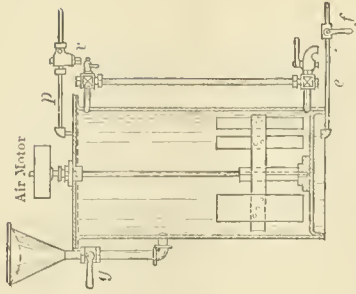

Fig. 4.

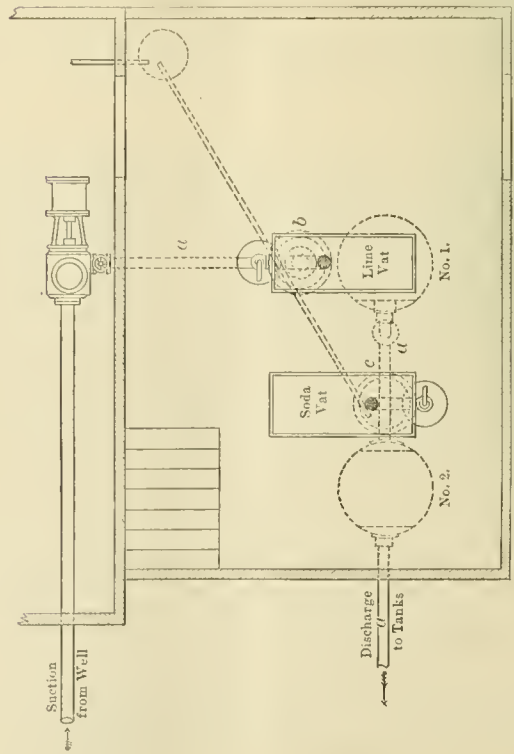
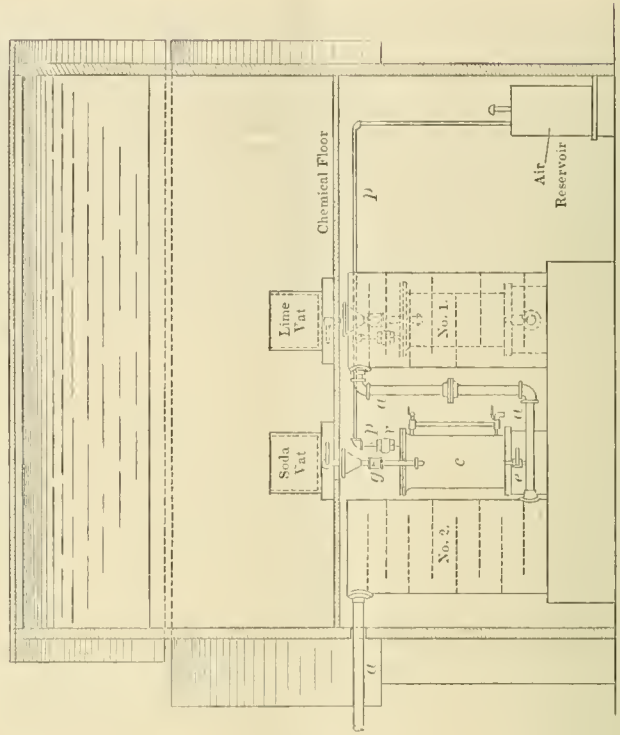

Fig. 5.



A RAILROAD WATER PURIFYING PLANT.

lime into the water in proper proportion to effect absorption of carbonic acid and consequent precipitation of carbonates in solution. The roily water now passes on through circulating tank No. 1, and this part of the desired reaction occurs more or less completely. As referred to before, the water supply at Port Los Angeles contains, besides the carbonates in solution, a large amount of sulphates, lime, and magnesia.

These salts, not being converted by quick-lime, required a second reaction. The use of the necessary amount of caustic soda to effect this would have been expensive, besides other objections to its use. Soda ash was good and cheap, but would react with the lime, directly, to form carbonate of lime if introduced with it; hence its use necessitated the second chemical tank, with its mixing vat, which is operated by the same method and simultaneously with the lime tank.

The soda tank is like Fig. 4, except that it requires no stirring device, as the solution is some distance from saturation and does not settle out. The weight of soda ash put into the soda mixing vat is dependent on same data as before, the amount required to convert the sulphates being 2 $\frac{1}{2}$ pounds (per 1,000 gallons), we have 4 by 11 by 2 $\frac{1}{2}$, or 96 pounds to be dissolved in water to 12 inches depth in the mixing vat.

The lime is prepared by placing the stated weight of a good commercial article (fresh burned) preferred in the vat and letting in from an adjacent hydrant enough water to slack, after which more water is added to the required 12-inch depth.

The soda is prepared in its vat in the same manner, except that it is simply a matter of solution which is quite strong yet not saturated, hence no separation or crystallization of sal soda occurs in the chemical tank.

As the water in the main receives its second injection from the soda tank, it passes on through the circulating tank No. 2, where the carbonate soda effects its reaction more or less completely, and thence on to the storage and settling tanks, which are at least large enough to contain 24 hours' supply. The treated water is milky with precipitated carbonates, and discharges through the inlet pipe about 4 feet from the tank bottom. The outlet to this tank is a piece of 4-inch wired hose, the open end of which attaches to a float on the surface, as shown in Fig. 2. By this means the clearest water in this tank passes on to the second similar tank by the same method. Clean water is always obtained from the surface outlet of the second tank.

The chalk deposit is considerable at the bottom of the settling tanks and has to be drawn off occasionally, which is effected by the "spider-drain" system shown in Fig. 2, which consists in tapping the tank bottom with seven 4-inch drain pipes. The location of these drains is shown in the plan of one of the tanks (Fig. 2), the drainage areas being indicated by the tangent dotted circles.

The vertical 4-inch drain pipes open into larger horizontal pipes, and these into a 9-inch pipe at right angles, terminating in the sludge valve shown at n, Fig. 2. This valve discharges downward into the sluice box, and when opened the tank bottom is drained from seven equidistant openings, which keeps the chalk deposit down near the tank bottom and prevents the "angle of slope" which the deposit would assume with but a single central discharge, whereby the deposit would accumulate up along the sides of the tank to interfere with clear settling, and would also require an occasional scraping or shoveling out. Each of the tanks is provided, independently, with this spider-drain arrangement, though both sludge valves discharge into the same sluicebox.

The following analyses are shown of the Port Los Angeles water supply in tabulated form "before" and "after" treatment. The analysis "before" is one of several which were made at intervals during a year previous to putting in the treating system. None of these analyses varied materially with the season. The analysis "after" was made about two months after the system went into operation, and is also one of several made during the past year, without showing material variation in the treated supply.

SOURCE OF SUPPLY, WELL IN BED OF SANTA MONICA CANON, ABOUT 100 YARDS FROM PACIFIC OCEAN BEACH.

Date of Analysis.	Before March, 1896.	After December, 1896.
Treatment per 1,000 Gallons.		Lime, 1 $\frac{1}{2}$ pounds. Soda Ash, 2 $\frac{1}{2}$ pounds.
Contained in the water in solution in grains per U. S. gallon :		
Carbonate lime.....	14.29	.69
Sulphate lime.....	5.67	.29
Carbonate magnesia.....	1.22	7.15
Sulphate magnesia.....	17.15	1.63
Silica.....	1.31	.11
Alumina.....	.17	.17
Sulphate soda.....	3.56	27.92
Chloride soda.....	8.75	5.71
Total.....	51.55	43.67
Incrustating matter.....	39.24	10.04
Non-incrustating matter.....	12.31	33.63

Cost per 1,000 gallons to treat, 1 cents.

While the treated water is not shown to be "purified" in the proper sense of the term, yet it is converted to a fairly good water for boiler use. Previous to treatment the water formed a large amount of very hard scale, with considerable corrosion.

A switch engine with clean boiler was put to work on the wharf at Port Los Angeles, using only treated water, not long after the plant was put in operation, and observations made at intervals on the action of the water. No scale forms from its use, but a small deposit of magnesia sludge, having no tendency to form scale, has at times been observed. Otherwise the treatment has greatly improved the quality of the supply.

The "standardizing" of the process for treatment of such waters as may thereby be benefited has been based on the following principals :

All tanks, vats, etc., to be made in sets of three sizes, the smallest being adapted to water stations having a delivery of 4,000 gallons per hour or less, the second 1,000 to 8,000 gallons, and the third 8,000 to 12,000 gallons.

Storage and settling capacity for a station to be sufficient for at least 24 hours' supply, unless circumstances allow other arrangement as to settling.

The character (from analysis) and rate of flow of water at a station being known, it remains to substitute such weight of re-agents in a circular of direction, properly posted at the water station, as will supply necessary instruction to a person of ordinary intelligence.

FROG AND GUARD RAIL PROTECTION.

An important bill, which deals with a familiar subject upon which legislation of the same character has heretofore been sought without success, has been introduced in Congress. It provides: "That all persons, companies or corporations owning and operating a railroad or railroads, or operating a railroad owned by another person, persons, company or corporation in the United States, or within the military reservations of the United States or the District of Columbia, shall, and are hereby required, within six months after the passage of this act, to adjust, fill or block or securely guard the frogs, switches and guard rails on their roads (with the exception of guard rails on bridges), in all yards, divisional, and terminal stations, and where trains are made up, as to thoroughly protect and prevent the feet of employees or other persons from being caught therein, with the best approved metallic appliances that are known up to date." The penalty for failure to comply with the provisions of the act is fixed at not less than \$500 or more than \$2,000 for each offense, and "each unfiled angle shall constitute a separate offense."

A PERMANENT EXPOSITION FOR NEW YORK.

A plan for a permanent exposition in the city of New York has been quietly maturing for some time, the Merchants' Association being apparently the most active influence in connection with it. The idea is to establish the exhibition in specially constructed buildings after the manner of similar institutions in London, Paris and Berlin. With a provision of \$20,000,000 to start with, it is expected that the European exhibitions will be surpassed, and there appears to be good reason to expect that this amount may be easily raised when needed. A committee representing various business and manufacturing interests is to be formed to carry the movement forward. The scheme is intended to provide means for extending trade and to facilitate the ordering of American productions without the necessity for spending a great deal of time in traveling about the country. The exhibits will provide for manufactures, from wire nails to locomotives and cars. One of the advocates of the plan, interviewed by a representative of the New York "Commercial," says:

"Foreigners are coming to look to Americans for everything that they need, and it is only just to them that we should make it as convenient as possible for them to secure our products. The venture has already secured such encouragement that there is no doubt whatever of its success. I am satisfied that after the first meeting, to be held in October, the matter will be in such shape that we can immediately open the subscription books, and that the necessary money will be forthcoming in a short time.

"It would be an exhibition in every sense of the word, with no music or ice cream or dancing in the evenings—nothing but business. Of the different buildings to be erected, each would contain a separate line of products. For instance, one with locomotives, passenger and freight cars, air brakes and the thousand and one things pertaining to railroads. The same building could also contain all of the appliances for traction cars and everything else used in the construction of a street car line. Thus, each line of trade will be housed in a separate building."

The legal department of the Lehigh Valley is to be removed to New York from Philadelphia.

The Northern Pacific has begun to restore wages by giving engineers an increase of about 15 per cent.

The Missouri, Kansas & Texas shops at Dennison, Texas, have been reopened. They were shut down about two months ago.

The track of the Flint & Pere Marquette, from Port Huron to Grindstone City, 92 miles, has been changed to standard gauge.

The Pennsylvania, under the revenue law, is put to an expense of about \$1,000 per month for check stamps, about 60,000 being used each month.

The New York, New Haven & Hartford application of the third rail electric system will probably be completed to Bristol within a few days.

The "New York Commercial" predicts that within a year the number of roads in the hands of receivers will be as small as it was in the years immediately preceding 1893.

Pullman conductors will stamp all sleeping and parlor car tickets when they take them up, thus relieving ticket agents of all trouble and responsibility in regard to the war tax.

The Pennsylvania is to continue the use of oil for laying dust on ballast, and it is found necessary to make a second application to the portlons of the road that were covered last year.

The Big Four has begun the practice of giving all repair work and rebalasting of tracks to contractors. It recently awarded a contract for rebalasting 100 miles of the St. Louis division.

It is reported from Austin, Texas, that the Gould railway interests are soon to be extended into Mexico, and that a representative has been making a careful inspection of the Monterey & Mexican Gulf with a view to its purchase.

Louisville is to have a new union station, the contract for its construction having already been let by the Louisville & Nashville Railroad to C. A. Moir of Chicago. It is reported that the new station will be the finest in the South.

The Chicago Pneumatic Tool Company, Monadnock Building, Chicago, recently received an unsolicited order for six pneumatic tools from the Japanese Government Railway. This is proof of satisfaction with the tools in Japan which is worthy of mention because of the low price of labor there.

The boiler plant of the Trans-Mississippi Exposition at Omaha, comprising 3,600 horse power, is contained in a floor space of 25x100 feet. There are six Morrin "Climax" boilers, four of which are capable of evaporating 22,500 pounds of water per hour each, and two can evaporate 15,000 pounds each.

The largest private yacht is Mr. W. K. Vanderbilt's Valiant, of 2,184 tons. To the builders, Laird Bros., Birkenhead, England, the Valiant cost considerably over a half million dollars, besides which very large sums were spent on French upholstery and cabinet work. To keep this boat in full commission takes between \$100,000 and \$125,000 per year.

The Receivers of the Baltimore & Ohio Railroad have purchased 40 miles of 85-lb. 60-foot steel rails and will experiment with them on the Pittsburg division and in the Baltimore tunnel. These rails were originally bought for the Columbia & Maryland Electric Railroad, which was designed to parallel the Baltimore & Ohio Railroad between Baltimore and Washington and to become an important factor in business between those points. The project failed and the material which was purchased has been sold. Those are the first 60-foot rails to be used on the B. & O.

An English friend has sent clippings from Birmingham papers to the "American Machinist" which show that one of the features of the Barnum & Bailey show, now over there, that attracts most attention is not included in the show proper at all, but is the cars that have been built for transportation of the show from place to place. They are fitted with automatic couplings, and these seem to be attracting great attention and also general commendation. English "shareholders" and others are

asking why English cars cannot be equipped with them, and are pointing out the advantages that would result from their use, especially in respect of decreased liability for accidents to trainmen.

The Illinois Steel Co., at its South Chicago Works, has rolled two of the largest open-hearth steel boiler plates ever made in this country, each of which will be used as the shell surrounding the fire box of a consolidation locomotive. Each of the finished plates was 124 inches wide, and 220 inches long on one edge, and 237 on the other; the original sheets before the shearing were 128 inches by 360 inches for one, and 130½ inches by 375 inches for the other, while the ingots from which they were rolled had a cross-section of 18 inches by 40 inches. The actual gauge of one plate measured at the four corners was 0.577 inches, 0.577 inches, 0.574 inches, and 0.576 inches, while at the ends near the middle the gauge was 0.640 inches and 0.623 inches.

One of the largest and best equipped power buildings in the United States is the Manufacturers' Building, Providence, R. I. This building has accommodations for upwards of 60 manufacturing concerns, being particularly well equipped with conveniences for the production of jewelry, specialties, etc. The Manufacturers' Building Company have just purchased a 250 K.W., 500 volt Westinghouse Electric & Mfg. Co.'s engine type generator, 100 r.p.m., to be driven by an Armington & Sims Corless engine. This generator will supply power for the operation of motors in the various manufacturing departments of the building. The engineering features of this establishment are under the direction of Lewis & Claffin, consulting engineers, whose wide reputation for engineering installations of the highest order is borne out by their selection in this instance.

The development of electrolytic processes for the production of refined copper has proceeded very rapidly during the past three years, and at the present time a very large proportion of all the refined copper is thus produced. The Westinghouse Electric & Manufacturing Company have installed a very large amount of apparatus for this class of service. One of the principal installations is at the refinery of the Anaconda Copper Company, Anaconda, Montana, where 10 generators of 270 to 300 K. W. capacity have been installed. Another very large installation is that of the Boston & Montana Consolidated Copper & Silver Mining Company, Great Falls, Montana, where two 810 K.W. Westinghouse engine type generators are in service. The latest comer in this field is the Raritan Copper Works of Perth Amboy, New Jersey, who are about to erect the largest copper refinery in the East. They have contracted with the Westinghouse Electric & Manufacturing Company for three 600 K.W., 150 volt, engine type generators, 150 r.p.m., with a 9 section switchboard for electrolytic service and the operation of two 75 K.W., 220 volt, engine type generators, which will be used for lighting and power service. The installation will be the most complete of its kind in the world.

A 16-inch coast defence gun is being constructed for the War Department at the Bethlehem Iron Works, Bethlehem, Pa., says a contemporary. This enormous gun will be placed somewhere in New York harbor, very likely in a turtle-back turret built upon Romer Shoals, which are almost directly in the center of a line drawn between Norton Point, Coney Island, and Sandy Hook light. Mr. J. F. Meigs, under whose direction the gun is being constructed, calculates that the striking energy of the projectile propelled by a 1,000-pound charge of powder will be 60,000 foot tons. This is approximately equal to the shock which would result were a 6,000-ton steamer brought to a sudden stop while running at a speed of sixteen miles per hour. The range of the gun will be over sixteen miles, and should the present plan be carried out New York will eventually be protected by fourteen such cannon. The following comparison made by Lieutenant Cardon of the biggest guns in the world shows the position that it is anticipated the American gun will hold:

	Calibre, in.	Weight of gun, tons.	Length, ft.	Weight of shell, lbs.	Weight of powder charge, lbs.
United States.....	16	126	49.1	2,350	1,000
Germany.....	16.5	120	45.9	2,204	903
Italy.....	17	104	49.75	2,000	900
England.....	16.25	110.5	43	1,800	960
France.....	16.54	74.2	32.5	1,719.6	595.2

EQUIPMENT AND MANUFACTURING NOTES.

The Barney & Smith Co. are building a business car for officers of the Lehigh Valley that is to be unusually handsome and well appointed.

The Northern Pacific is changing its refrigerator cars to the Wickes system, also the Chicago, Milwaukee & St. Paul has built 250 cars on this system in its own shops, and the Grand Trunk is now building 250 of these cars in their own shops.

The Chicago Grain Door was specified for 1,000 cars which the Chicago, Milwaukee & St. Paul Railway is to build at the West Milwaukee shops and for 1,000 cars for the Northern Pacific, to be built by the Michigan Peninsular Car Co. and the Illinois Car & Equipment Co.

The Sargent Company announces the largest month's business in patented brake shoes in the history of the company for June, 1898. They are extremely busy in the steel department and running to the full capacity, with prospects of heavy business throughout the year.

W. D. Sargent, President of the International Brake Shoe Co., has sailed for Europe, to make arrangements for the manufacture of the Diamond "S" shoe brake in several European countries, including Russia. The success of this shoe since its introduction last Fall has been remarkable.

The Carnegie Steel Company is reported to have received the contract for furnishing 4,500 tons of steel for use in the projected track elevation of the Chicago & Northwestern Railroad at Chicago. It will also supply the Western Electric Company with 1,200 tons of steel for building purposes in Chicago.

The sale of the car works owned by the Memphis Car & Foundry Co., at Memphis, Tenn., has been confirmed, the property passing into the hands of C. J. Wagner, who acquired it at a cost of \$25,000. Mr. Wagner states that the plant will probably be run by local parties, if the proper arrangements can be made.

The Schenectady Locomotive Works are building the following locomotives: Ten Mastodon compound locomotives and seven 8-wheel passenger locomotives for the Southern Pacific, fifteen 10-wheel freight for the Chicago & Northwestern, twenty-six locomotives for the Nippon Railroad of Japan, twelve consolidation freight locomotives for the Kiushu Railroad of Japan, and one engine for the Chicago & West Michigan.

The Schoen Pressed Steel Company of Pittsburg is building a 120 by 650-foot addition to its plant in the form of a steel building, which will be fitted with four 60-foot overhead cranes and other tramways for handling material. It will be ready for use in about a month, and will increase the capacity of the works to thirty complete cars per day, aside from the bolster and truck business. The Baltimore & Ohio has just ordered Schoen bolsters for 3,750 cars.

The Brooks Locomotive Works are building: One American type passenger and four consolidation engines for the Chihuahua & Pacific, two locomotives for the Duluth, Missabe, & Northern, one narrow gage, mogul engine for the Tionesta Railroad, two narrow gage, consolidation engines for the American Railroad & Lumber Company, eight engines for the Pecos Valley Railroad and three passenger and two side tank freight engines for the Hankaku Railroad of Japan.

"Simplex" body and truck bolsters have been specified for 500 cars for the Wabash and 268 cars for the Choctaw, Oklahoma & Gulf. The former lot are building by the St. Charles

Car Co. and the others by the Mt. Vernon Car Manufacturing Co. These bolsters, in the opinion of one of our best known motive power officers, who is also in charge of cars, as expressed in conversation with a representative of the "American Engineer," are the lightest that can be made for their strength.

There has been a growing demand among belt users for a more convenient form of belt dressing than the paste. The Joseph Dixon Crucible Co., Jersey City, N. J., are now placing on the market a solid belt dressing in round bars, about eight inches long and two inches diameter. It makes a package convenient to the hand and easy to apply even to fast running belts. The company does not claim that the solid dressing is as good a preservative of the life and elasticity of the leather as the Dixon paste, but it is quick to apply and quick to act, and that is what is wanted by the general run of belt users.

A cargo of steel rails for the Trans-Siberian Railroad in Russia was cleared in July from Sparrow's Point, Md. The British steamer "Venus," loaded with 11,230 tons of steel rails, 6,799 bundles of plates and 4,606 boxes of bolts and spikes, has sailed for Vladivostock, making the sixth cargo sent to that port with parts of the order for forty thousand tons given to the Maryland Steel Co. The value of the cargo of the "Venus" is placed at \$69,551. The large British steamship "Strathnevis," about due, will also load for Vladivostock, and it is expected this ship will nearly complete the order, although the steamship "Marao," with a capacity for about 10,000 tons, has been reported chartered.

The McCord journal box and lid have been specified on 250 cars for the St. Joseph & Grand Island, for which orders are about to be placed; on 500 cars ordered by the Northern Pacific from the Michigan-Peninsular Car Company; on 35 logging cars for the Brainard & Northern Minnesota, ordered from the Illinois Car & Equipment Company, on 25 cars ordered by the Iowa Central from the St. Charles Car Company; on 200 cars for the Minneapolis & St. Louis, ordered from the Michigan-Peninsular Car Co.; on 20 cars for the Rio Grande & Eagle Pass, and on 250 cars for the Delaware & Hudson Canal Co., ordered from the Buffalo Car Works, and have been made the standard on the last named road.

It is reported from Chicago, says the New York "Commercial," that a new corporation is to be formed with \$20,000,000 capital, and it is to take over all the assets of Pullman's Palace Car Co., which do not directly relate to its regular business of operating sleeping cars or car building. Its securities will be divided among Pullman's stockholders as an extra dividend. They can hold or release these as they see fit. The report further says a prime advantage of the course will be that the Pullman Co., after such division, will be in a better shape to negotiate with the Wagner Palace Car Co. for a consideration on a basis which will be easier to bring a consolidation about. It is not believed that this plan will be carried out before the regular meeting in October. If there is any such consolidation it is believed the Pullman Co. will be absorbed by the Wagner.

The Baltimore & Ohio Railroad has adopted the use of electric fans on sleeping cars, following the example set by the Baltimore & Ohio Southwestern at Cincinnati, Louisville and St. Louis. At Washington and Mt. Royal Station, Baltimore, the Baltimore & Ohio has sleeping cars which lay for several hours awaiting the departure of trains, thus enabling the passengers to retire several hours before the time of departure of the trains. Ordinarily a railway station is about the hottest place that can be found at night in the Summer, and the interior of a sleeping car is still hotter; if such a thing can be. The fans are placed in the cars as soon as they are backed

into the stations, connected by a flexible cable with the electric current, and they run until ten minutes before the train leaves, thus keeping the interior of the car cool and pleasant for those who are sleeping. The cost is very small, as each station is thoroughly equipped with electric appliances.

The Safety Car Heating and Lighting Company, has prepared a handsome, large wall map of the United States, showing in red lines the railroads using Plintsch gas for car lighting. As this lighting system is used by over a hundred different roads, 90 of which are steam railroads, the red lines, particularly in the eastern section of the country, practically cover all of the railroad lines, forming a striking demonstration of the rapidity with which this business has extended. The equipment of Pullman and Wagner cars is not included in these figures. On the map are stars indicating the gas supply station plants, of which there are now 47, which are located at the chief railroad centers of the country. The use of Plintsch gas in the lighthouse service is extending, 106 gas buoys having been put into service by the Government already. These buoys burn continuously, day and night, for six months or more, according to the size of the storage reservoirs, without requiring any attention. The gas in the tanks of the buoys is compressed to about 180 lbs. pressure per sq. in.

Since war operations have begun, the Wells Light Manufacturing Company, 44 and 46 Washington street, New York, have been busy making shipments of their lights to various places to meet the needs for brilliant and efficient illumination at fortifications, for coast line defence and similar work, which they completely fill. This company has also made a large consignment of their lights to Cuba within the past few days, as the Wells Light has proven itself to be one of the very necessary outfits of war. For facilitating unloading troops, equipment and supplies from transports, the building of roads, fortifications and intrenchments good lights are indispensable, and portable outfits which may be set up anywhere are always needed, especially in campaigning. They are also valuable in hospital service and in caring for the wounded and dead on the battlefield, more attention being now paid to lighting than ever before. The adaptability of this form of light to railroad construction and wrecking service is too well understood to require comment, but it may be said that these always ready, portable, self contained lighting outfits, which may be used out of doors in all kinds of weather, and under cover, if necessary, are growing more popular, with good reason.

OUR DIRECTORY

OF OFFICIAL CHANGES IN JULY.

Astoria & Columbia River.—Mr. T. W. Hansell has been appointed Superintendent of Machinery, with headquarters at Astoria, Ore.

Atlantic Coast Line.—Mr. R. E. Smith, who was Superintendent of Motive Power, has been appointed Assistant to the General Manager. Mr. T. H. Symington succeeds Mr. Smith as Superintendent of Motive Power.

Baltimore & Ohio.—Mr. John M. Marstella, Master Mechanic of the shops at Martinburg, W. Va., died in that city June 25, from a stroke of paralysis.

Bangor & Aroostook.—Mr. F. E. Rogers, Assistant Superintendent, has resigned and Mr. W. M. Brown, heretofore Assistant Superintendent at Bangor, Me., has been appointed Superintendent of the entire line.

C., C. & St. L.—Mr. George Tozzer has been appointed Purchasing Agent, succeeding the late A. M. Stimson, deceased. He was formerly Assistant Purchasing Agent.

Detroit & Lima Northern.—Mr. Charles N. Haskell has been elected Vice-President.

Detroit, Toledo & Milwaukee.—Mr. H. S. Rearden has been appointed General Superintendent, with headquarters at Toledo, O., to succeed Mr. N. K. Elliott, resigned.

El Paso & Northeastern.—Mr. C. F. Winn, who has been appointed joint Foreman of the Denver & Rio Grande and the Rio Grande Southern at Durango, Colo., has been appointed Master Mechanic of the El Paso & Northeastern at El Paso, Tex.

Erie.—Mr. A. L. Hopkins, President, and Mr. Roswell Elbridge, First Vice-President of the New York, Susquehanna & Western, have retired since July 1, owing to the transfer of the road to the Erie. Mr. F. P. Moore, Second Vice-President and Treasurer, becomes Third Vice-President, and the following officers of the Erie have been elected to corresponding positions on the acquired road: E. E. Thomas, President; G. M. Cummings, First Vice-President; W. F. Merrill, Second Vice-President.

Eastern Railway of Minnesota.—Mr. D. M. Philbin has been appointed Second Vice-President.

Eastern Ohio.—Mr. J. W. Campbell has resigned as General Manager and the office has been abolished and its duties assumed by Mr. W. H. Stevens, General Superintendent.

Flint & Pere Marquette.—Mr. David Edwards, formerly General Manager, died July 18 in Detroit, at the age of 56 years.

Plant System.—Mr. T. S. Tutwiler has been appointed Chief Engineer, with headquarters at Savannah, Ga.

Galveston, Laporte & Houston.—Mr. T. W. House has been elected sole receiver in the place of Mr. M. T. Jones, deceased.

Great Northern.—Mr. N. D. Miller has been appointed Chief Engineer to succeed Mr. J. F. Stevens, resigned.

Grand Trunk.—Mr. William Cotter has been appointed Superintendent of the Western division, with office at Detroit, Mich., to succeed Mr. A. E. Atwater, resigned.

Great Southern & Florida.—Vice-President William C. Shaw has issued a notice that owing to the death of General Superintendent and Purchasing Agent Jeff Lane of Macon, Ga., the duties connected with the now vacant office will be discharged by the Vice-President.

Indiana, Illinois & Iowa.—Mr. T. P. Shonts, who has been General Manager for twelve years, has been elected President to succeed Mr. F. M. Drake, resigned. Mr. George H. Holt has resigned as Vice-President and Mr. Joy Morton has been chosen to succeed him, with office in Chicago.

Illinois Central.—Mr. M. S. Curley has been appointed Master Mechanic of the shops at Water Valley, Miss.

Manistique & Northwestern.—Mr. A. J. Fox of Detroit, Mich., has been chosen President in place of A. Weston, deceased.

Kansas City, St. Joseph & Council Bluffs.—Mr. C. E. Lamb has been appointed Master Mechanic.

Louisville, Evansville & St. Louis.—Mr. Edward D. Seitz has been appointed Purchasing Agent in place of Mr. W. W. Wentz, resigned.

Montana Union.—Mr. Wm. H. Burns, Vice-President and General Manager of the Montana Union, has retired from that position owing to the absorption of the road by the Northern Pacific, and the jurisdiction of the officers of the latter has been extended over the Montana Union.

Minneapolis, St. Paul & Sault Ste. Marie.—Mr. Thomas Green has been appointed Acting Chief Engineer of this road to succeed Mr. W. W. Rich, resigned.

Mobile & Ohio.—Mr. George W. Stevens has been appointed Purchasing Agent, with headquarters at Mobile, Ala. He was formerly Purchasing Agent and Superintendent of Car Service of the Cincinnati, New Orleans & Texas Pacific.

Omaha Bridge & Terminal Co.—Mr. P. J. Nichols has been appointed Superintendent. He was formerly General Superintendent of the Pacific Division of the Union Pacific.

Poughkeepsie & Eastern.—Mr. Joseph J. Slocum has been appointed Receiver.

Puget Sound & Gray's Harbor.—Mr. S. G. Simpson has been chosen President in place of Mr. J. A. Campbell, with headquarters at Seattle, Wash.

Rio Grande, Sierra Madre & Pacific.—Mr. L. P. Atwood has been appointed Chief Engineer.

St. Louis, Avoyelles & Southwestern.—Mr. N. G. Pearsall has been appointed General Manager.

St. Louis Southwestern.—Mr. William Coughlin, Division Superintendent at Pine Bluff, Ark., has been appointed Assistant General Superintendent of that system, with office at Tyler, Tex. He will have immediate charge of transportation and maintenance of way. Mr. S. W. Kenward succeeds Mr. Coughlin as Division Superintendent at Pine Bluff, Ark.

Texas Western.—Mr. Henry Haynes of Brenham, Tex., has been appointed Receiver.

Union Pacific.—Judge William Cornish of St. Paul, Special Master in Chancery of the Union Pacific, has been elected its First Vice-President, vice Oliver W. Mink. He will shortly remove his headquarters to New York. Mr. Peter J. Nichols, General Superintendent of the Union Pacific, has resigned. His position as General Superintendent will not be filled. Mr. R. W. Baxter, now General Agent of the freight and passenger department of the Union Pacific at Portland, Ore., will go to Omaha as General Superintendent.

Velasco Terminal.—E. D. Dorchester, formerly Secretary and Assistant General Manager, has been appointed General Manager. He succeeds the Hon. L. L. Foster, who recently resigned.

West Shore.—Mr. G. E. Hustis has been appointed General Superintendent of this road to succeed Mr. C. W. Bradley, resigned.

AMERICAN ENGINEER CAR BUILDER AND RAILROAD JOURNAL.

SEPTEMBER, 1898.

CONTENTS.

ILLUSTRATED ARTICLES:	Page	MISCELLANEOUS ARTICLES:	Page
Future Development of the Locomotive	290	Advantages of Small Grates	294
Iron Signal Poles, C., M. & St. P. Ry.	292	The Government and the Metric System	294
Driving Axles and Crank Pins	294	Mechanical Draft	297
Consolidation Locomotive—B. & M. R. R.	296	Importance of Knowing Costs	298
Cast Steel Bolsters, Seaboard Air Line	299	Engineering Notes	307
Tests of Staybolts	300	Steam Consumption in Stationary Engines	308
DeLaval Turbine and Boiler	303	Train Signaling in England	309
Westinghouse Engines and Generators	303	Car Side Bearings	310
Hedley's Motor Car Truck	305	Improved Tools for Railroad Shops	316
Wood's Car Seal	309	Diesel Motor at Munich Exhibition	317
A Smooth Running Air Compressor	310	Cylinder Fastenings for Locomotives	318
Tests on Steam Pipe Coverings	311	Books and Pamphlets	319
Convenient Pneumatic Appliances	312		
Microstructure of Bearing Metals	313	EDITORIALS:	
Heavy Chipping with Pneumatic Hammer	317	The "Battle of the Gages"	306
		Piecework Prices	306
MISCELLANEOUS ARTICLES:		Modern Machines in Shops	306
A Chapter in Metrology	289	Segregation in Bearing Metals	306
Application of Electric Motors to Machine Tools	293	Side Bearings for Cars	306
		The Metric System	307
		Tests of Locomotive Lagging	307

A CHAPTER IN METROLOGY.

By Edward Grafstrom.

Spasmodic efforts to revolutionize the country's system of weights and measures by substituting the metric standards for the English, have been made from time to time, and will undoubtedly be repeated until eventually the goal is reached. That these efforts so far have been unsuccessful is due to defective methods employed by the advocates of the metric system to gain their ends, or perhaps to their lack of method and disregard for local conditions.

That the day will come when there will be a universal system for measuring the products and commerce of nations, is in the destiny of the world, and what this system is to be is told by the 500 millions who to-day are using the meter, a modern production, while the Anglo-Saxon race is still in sole possession of that remnant of a past civilization, the ancient yardstick.

Although it originally was a feeling of insular conceit which made England decline the invitation to be present at the birth of the meter a century ago, the advantages of the metric system are now generally admitted by every Englishman and American who has given the subject an unprejudiced study. For him it has simply become a question whether these advantages are worth the cost and trouble which it would take to transfer the immense commercial and industrial system of these countries from one standard to another.

But the masses do not look upon the subject in the same light. They are contented with what they have, because they have never felt the need of anything better. The new names are "Greek" to them, and even the decimal system looks suspiciously meaningless. The British are peculiarly tenacious of old customs, as are Americans of what they regard their personal rights. No Parliament or Congress would care to show its strong hand and use its constitutional right to take the decisive step in the face of such opposition by the majority of the voters. Compulsory adoption of the metric system in this country, as in England, depends upon the people, and there will be no public demand for it as long as its value is beyond the comprehension of the masses.

The question may be asked: Why is it, then, that the introduction of the metric system has been so thoroughly successful in other countries? It is certainly not that the Anglo-Saxon mind is more dull or less susceptible to new ideas. On the contrary, it is, perhaps, the characteristic energy of the race which has been one of the barriers to the new system: to do the work of a lifetime in a couple of years.

The answer to the above question will, instead, be found in the history of each nation, in the political events of the time at which the change was made. In the restless period following upon the revolution and the advent of Napoleon, the volatile minds of the French people were ready for anything which would assist in overthrowing the old conditions. New social

habits, new governments, succeeded one another. The map of Europe was remodeled. New coinage was introduced, and even the reckoning of time was meddled with. What could be more natural than that the new system of weights and measures should meet with favor? But in spite of Napoleon's edicts and the revolutionary spirit of the time, it took France 40 years to settle down to the undisputed use of the meter.

In Germany the change came with the new empire. A common unit was needed to promote interstate traffic and trade between the many principalities constituting new Germany, and for that purpose the victors brought home the meter from vanquished Paris at the end of the Franco-German war.

The history of many other metric countries also shows that the time of change was not arbitrarily chosen, but was connected with other important events. The public was prepared for the change either by circumstances or by a paternal and far reaching government. In countries previously possessing well developed systems of weights and measures, the transitional period was of sufficient length to avoid unnecessary hardships and expenditures.

The writer has had the fortune, or perhaps the misfortune, to live successively in two countries during such periods of transition, and for the purpose of illustration it may be interesting to relate the developments connected with the evolution. The time allotted for the purpose was in one case 10, in the other 8 years. Each one of these countries was up to that time following a system of foot and pound but slightly varying from the English standards.

The first indication of the advent of a new system came from the schools, the educational branch being under full government control. In the primary schools the children were taught the metric system before the intricacies of the old system were explained, and in the higher grades and colleges mathematical examples were worked on the metric basis. Within a year enterprising publishers put on the market metric editions of mathematical and other text books affected by the change. The new idea took root at once and threw in the fresh minds of the pupils, and later when these thousands of adherents to the new system were turned out in the world, year by year, the popularity of the system was assured. But the great mass of people, who were already beyond the reach of the school, had to be converted in the meantime.

The next step was in the form of an object lesson. On all the government railroads the distances were remeasured and kilometer posts put up in addition to the old mile posts. On station buildings the distances in kilometers were added. In the country districts such public highways as had old mile posts were next supplied with new ones, leaving the old ones undisturbed. These steps gave the traveling public, the railway men, the farmers, opportunities for comparison and reflection.

About this time new foot rules, weights and scale balances, graduated on both systems, also began to appear, and advertisements in the form of calculated converting tables and mechanical converters were freely distributed. People began to be educated up to the point of change.

The following year all applicants for position in the civil service were required to be thoroughly familiar with the metric system, and private employers soon followed lead. The system began to be tested. People bought silk and ribbons by the meter in the dry goods stores, coffee and tea by the kilogram in the grocery, and called for a liter of beer at the restaurant. It soon became a fad. You were not up to date if you didn't handle the meter system with perfect familiarity. Four years had passed, not a single compulsory step had been taken to inconvenience the public, and yet from all outward signs the country was on a meter basis.

The next step was to put the postal, railway and custom tariffs on the same plane. When they were introduced there was no confusion or interruption; they fitted right in with the situation, and everybody understood them and was expecting them.

So far no change had apparently been made in the manufacturing industries. Dimensions of new machines and tools began to be evened up to avoid fractional millimeters wherever possible. Screw taps and reamers were named after their nearest metric size, but master gauges and test blocks were not, as a rule, interfered with. The rolling mills altered their rolls imperceptibly as new ones were needed. There was no abruptness, no interruption, and the extra expenditure was compensated for by the time saved in making calculations and estimates, or in keeping shop and material accounts.

Before the period of transition had expired the metric system had infused trade and commerce, and become part of the national life. But the evolution had taken place under the guiding hand of a centralized government, which controls schools, railroads and telegraphs, and exerts a subtle influence over all other public institutions.

In the United States the conditions are so vastly different and the undertaking of such magnitude, that the problem could not be treated in the same manner. It is doubtful

whether the national government could do much more than it already has done. In 1866 an act of Congress authorized the use of the metric system. The two standard meters, Nos. 21 and 27, and the two standard kilograms, Nos. 4 and 20, which President Harrison officially received in 1890, are the prototypes of the only measures and weights made lawful in the United States. The treasury department has so recognized them, by defining the yard and the pound as certain parts of the standard meter and kilogram. In 1893 Congress adopted a standard metric sheet metal gauge, which has since been used exclusively for fixing duties and taxes levied by the United States.

What more can be done by a government which is depending on a majority of the people for its existence? It has legalized the use of the meter and adopted it for its own need, as far as it is possible without interfering with the commerce of the country. For those that want to use the system it is there, and pharmacists, electricians and some other classes have availed themselves of it for professional use. But the vast multitude do not at present ask for it, and Congress does not legislate except in accordance with the wishes of the majority.

Until public opinion is favorable to the change it is, therefore, impossible to see how any practical advance can be made for the metric system. Some great event of national importance may occur, either in this country or in England, which may throw another light upon the subject, and if it should cause either one of these two great nations to feel that the time had arrived for making the change, the other would soon follow.

American export trade is certain to be extended as a direct result of the present war, no matter what the foreign policy of the country will be. That the future relations with Spain's former colonies would not necessarily have any influence on the weights and measures of this country is shown by a statement made last year before the British Institution of Civil Engineers, that England's trade with her colonies and with the United States is only 10 per cent. of her total foreign commerce, the other 90 per cent. being principally with metric countries. In the same manner this country will develop its trade in the new markets in proportion to its advantages in location and facilities, regardless of the metric system, but in the face of the strong competition with English, French and German producers the adoption of that system would greatly assist American exporters. The manufacturers in England, who have adopted the metric system, have done it for similar, purely commercial, reasons.

It is not for the exporters or shippers to revise the country's system of weights and measures, however, except as far as concerns their own use. Nor is it for the railroads to base their rates and tariffs on units unfamiliar to their customers. It is a matter for the whole population to decide, and as long as the majority of the voters do not see how they could gain anything by the change, they will have none of it.

It remains, then, for the believers in the metric system to work for a reversal of the majority's opinion, to create a favorable sentiment for the new measure among the masses. It is not the object of this article to point out how this may be done, but suffice it to say, that here, as in other countries, the school is the first place where the seed should be sown. True, the schools have for years taught the metric system, but not for practical use, not on the same level as the English, but more as a sort of a side issue, a curiosity, which has been forgotten as soon as the school door closed behind the pupil.

In England there is a steadily growing society for the promotion of the metric system, and the suggestion is made that such an institution in this country might possibly bring together the friends of the system in all walks of life, in the educational branches, in railroads, manufacturing and commerce. By concerted action such a society might succeed to take one step after another, and to gradually lead the masses up to the point where legislative action could be taken without opposition.

[The attention of our readers is directed to the fact that the American Metrological Society was organized in 1873 for the purpose suggested by Mr. Grafstrom. Its present officers are: President, Prof. T. C. Mendenhall, who is President of the Worcester Polytechnic Institute and was formerly Superintendent of Standard Weights and Measures of the United States Government; Secretary and Treasurer, Prof. J. H. Gore, Columbian University, Washington, D. C. We also direct attention to the communication by Prof. T. C. Mendenhall on another page of this issue. It should be stated that the American Railway Association has considered the subject of the metric system and will take it up in the form of a committee report at the next convention.—Editor.]

THE FUTURE DEVELOPMENT OF THE LOCOMOTIVE.*

By Maurice Demoulin, Engineer.

The locomotive is at present in most countries undergoing an interesting evolution, tending to make it a more suitable instrument for hauling increasingly heavy loads at higher and higher speeds; in other words, to increase its actual power, its power per unit of weight and its stability. The limitations due to the strength of the road and bridges or to the gage and clearance, to the minimum permissible radius of curves, to the length of turntables and to other special circumstances combine to render the problem more difficult every day. But up till now the locomotive has fulfilled all requirements and has developed in proportion to the traffic. And if we were tempted to believe that it had almost attained the extreme limit and that its further development was stopped by the restricting circumstances with which it is surrounded, we need only cast a glance at what is happening on the other side of the Atlantic, and we shall be convinced that the limitations are of a very elastic nature, and that they can be considerably stretched. We find, moreover, especially in France, Belgium and Austria, tendencies similar to those which have lately led to such remarkable changes in American engines. It is therefore not without interest to see, in a general way, what these tendencies now are and to what types of locomotives they may lead, types which will besides vary less and less according as, in the future development of the locomotive, the dimensions of its principal parts reach determined limits. In short, the variety of types ought to decrease as the difficulties met with in the arrangement of their parts increase. For instance, when in 4-coupled engines the dimensions of the fire-box grow to a given extent, there remains only one, or at most two, methods of arranging the fire-box relatively to the wheels; similarly when the diameter of the cylinders exceeds a certain limit, they cannot be placed inside the frame plates, and con-

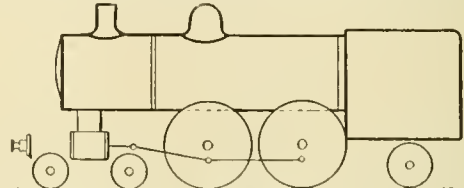

Fig. 1.—Development of the Modern 4-Coupled Locomotive.*

sequently the inside cylinder arrangement, at present much in use, must disappear.

It is necessary to differentiate between increases of absolute power and increases per unit of weight. If the absolute power only of a locomotive be increased, its weight becoming proportionately greater, heavier loads could, it is true, be hauled at given speed, but the maximum speed possible would not be greater, for this could only be attained by increasing the power per unit of weight.

I mean here by power the work which a locomotive can do, and not merely, as is sometimes meant in railway parlance, the capacity an engine possesses of hauling a load; in other words, I am considering the power developed on the pistons, or at the rim of the wheels, or at the draw bar, and not exclusively the amount of tractive effort, more or less apart from all idea of speed.

The increased power per unit of weight may be attained by

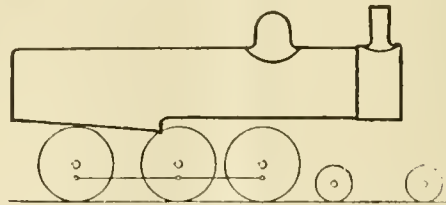

Fig. 2.—Development of Modern 6-Coupled Locomotive.

the reduction of dead weight without the total power of the motor being altered.

An increase of the absolute power and in the power per unit of weight at the same time may be attained by greater economy (in consequence of a better utilization of the heat produced) and by increased steam production in the boiler.

An increase of the absolute power alone can be effected by increased capacity of the boiler and cylinders.

Improvements in the quality of metal used can only be regarded as a means capable of increasing, quite indirectly, one

*From a paper in the Bulletin of the International Railway Congress.

of the two above-mentioned powers, and then only in consequence of the greater economy thus obtained. Engines can in this way be made more flexible and be made capable of containing in their boilers a greater quantity of potential energy.

We will now discuss, as briefly as possible, how and to what extent engines can under present conditions be made more powerful and less heavy.

Increase in an engine's absolute power depends upon the boiler. It is easy enough to increase the cylinders as much as one likes and construct the other moving parts in proportion, but to increase the power of boilers is far from being so easily managed, although we are, at least in Europe, far from having attained the extreme possibilities which, owing to the increasingly general tendency to raise boilers, have been extended far beyond the limits that it formerly seemed reasonable to expect.

When the fire-box comes down between the frame plates its outside measurement must be a little less than the distance between the frame plates, or about 4 feet 7-16 inch, and this must be further reduced by some 1¼ or 1½ inches if the fire-box is to be situated between the horn plates of one of the axles. If the frame plates are outside the wheels, a practice once very common in Europe and still usual on the Belgian state railroads, the width of the fire-box is no longer limited, but by external measurement may be easily made about 4 feet 1¼ inches. Besides, the axle boxes and their slides, which are outside, no longer interfere, and this permits of the fire-box ring being put nearer the axle beneath it, and, as the height of barrel remains the same, the fire-box can be made deeper.

But, as the fire grate cannot be made indefinitely longer—the maximum length being limited, through its being necessary to allow of free enough action of the fire, to about 9 feet 2¼ inches, though as much as 10 feet 2 inches has been tried—it is impossible, when the fire-box reaches between the frame plates, or only between the wheels, to make the grate area appreciably more than 32 square feet. A grate surface such as this is obviously sufficient with ordinary fuel to develop enough power to haul the heaviest and fastest trains at present run, but it would not be enough to do the work if less good or very small coal, or coal such as anthracite, were used. It will not suffice as soon (and the day may soon come as it becomes necessary to run heavier and faster trains and to go up gradients at higher speeds. The necessary power will be deficient, inasmuch as the rapidity of combustion can-

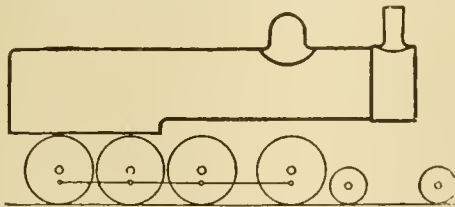

Fig. 3.—Development of the Modern 8-Coupled Locomotive.

not be proportionately as great on large grate surfaces as on small ones. Three times as much fuel will not be consumed on a grate with an area of 32 square feet as on a grate with an area of 11 square feet. The way in which the fire is kept up and the method in which locomotive fire-boxes are arranged, the quality of the fuel remaining constant, tend to reduce the quantity of coal that can be burned per unit of time and per unit of grate area if this be increased. As soon as the grate area exceeds a certain figure we must expect to find a reduction in the power it is capable of developing per square foot. This is all the more so in that fire-boxes with considerable grate area are as a rule less deep than others, because they must be above one axle or even above the trailing wheels, and it is a recognized fact that rapid combustion can only be successfully obtained in deep fire-boxes fitted with a brick arch and in which there is a strong draft.

The only way in which the grate area can be made greater than about 30 square feet, or at most 32 square feet, is to enlarge the grate itself beyond the limits dependent upon the distance between the frame plates or tires, and to do this we must fix the fire-box ring high enough to enable it to lie either above the frame plates or above the wheels. If the fire-box is situated completely above the frame plates, it can, consistently with the continued use of inside frames, be made as wide as in the case of outside frames. There is thus but little gained, and to make the alteration of much avail the grate must be put above the trailing wheels, which makes it possible to have the fire-box as wide in outside measurements as the available clearance allows. This is nothing new, for it was tried before by Mr. Petiet in France and shortly after in Belgium by Mr. Belpaire, who has made it a current practice during the last fifteen years. In the United

States Mr. Wootten has gone a step further, which has enabled him to use a grate area of 86 square feet in some very powerful engines burning anthracite coal.

In Belgium they have confined themselves to applying the enlarged fire-box to engines with coupled wheels 5 feet 7 inches in diameter, or to express engines in which the fire-box only extended above a carrying axle mounted on wheels of small diameter, the fire-box not being enlarged in the part lying between the coupled wheels. This, however, necessitated having the center line of the barrel about 7 feet 10½ inches, or 8 feet ½ inch, which was at one time exceptional in Europe. In America they have gone still further; this arrangement is now used in 4 or 6-coupled express engines, with a wheel diameter of from 6 feet 2¾ inches to 6 feet 6¾ inches. The fire-box ring is thus as much as 6 feet 10 11-16 inches above rail level, and the center line of the boiler 8 feet 10 5-16 inches. Despite all this the fire-box is exceedingly shallow, and is hardly suitable for burning poor coal; and yet we must not lose sight of the principle that the locomotive, which ought to be kept as light as possible, ought also, if speed is to be increased, to be less heavy per unit of power, and it is essential to maintain rapid combustion in the fire-box unless the increased grate surface is intended to allow of poorer fuel being used, which is not what we are here considering. To accomplish this it is absolutely necessary to have the fire-box deep enough, and this cannot be done under the above circumstances without raising the boiler and center of gravity to an impossible extent, not to mention that the height of bridges would not always permit of such a large boiler.

It appears, therefore, as if in future engines, designed to have very large grate areas and intended, we repeat the point, to have increased power, but not to allow of inferior fuel being used, we shall have to resort to arranging the axles after the fashion adopted by the Belgian state railroads for their engines of class 12, and which for more than twenty years has been customary with the Orleans Company. But it will also be necessary to make some alterations with a view to making the stability proportionate to future increases of speed. The two coupled axles will be carried under the barrel, the trailing wheels being in front of the fire-box, which it will be possible to make as large as the loading gage allows of. A pair of carrying wheels whose diameter does not exceed 4 feet 3¼ inches will be situated under the grate, and the front of the engine will be carried on a bogie, which will be all the more necessary because the cylinders, owing to their large diameter, will have to be outside. We thus arrive at an arrangement, shown in Fig. 1, which seems to meet all requirements.

The two coupled axles are very close together, but this will only tend to favor high speeds, because the coupling rods are less strained by centrifugal action. The absence of wheels of large diameter will permit of our making the fire-box as extensive as the clearance permits of. The leading bogie insures stability and allows of the weight being distributed properly. In this way express locomotives can be constructed with a grate area of as much as 65 or 75 square feet (6 or 7 square meters) and having a heating surface of about 2,380 square feet, while the barrel, owing to the height at which it is situated, can be of as large a diameter as required without our having to consider what is the distance between the tires of the coupled wheels, whether their diameter be 7 feet 2½ inches or more. An engine such as this would weigh from 65 to 68 tons in working order, and would, we believe, be capable of hauling express trains weighing 400 tons at an average speed of 46.6 or 49.7 miles an hour on main lines with average gradients.

Locomotives of this pattern, which would seem to constitute the latest and most powerful type of 4-coupled engine, are already beginning to be taken up in the United States (Philadelphia and Reading, and Chicago, Milwaukee and St. Paul railways) and they will find increased favor in Europe in proportion as the weight of express trains increases while the speeds are far from being reduced.

When the diameter of the driving wheels is kept below about 5 feet 8¾ inches the fire-box must still be of a fair depth, and as the axis of the barrel can, without inconvenience, be as much as 9 feet 2¼ inches above the rail, the enlarged fire-box can be situated above the coupled wheels, and no special arrangements are necessary either in the case of 6 or 8-coupled engines unless it be the use of a leading bogie or Bissel truck, which is needed to carry the additional weight due to the increased power of the boiler, so as not to make the load per axle too high. We thus come back to the recognized types, shown in Figs. 2 and 3.

We trust soon to be able to show by what means we may hope to extend the limits, wide as they still are, within which this class of engine is confined, and to show the possibility of building engines capable of developing as much as 2,500 indicated horse power.

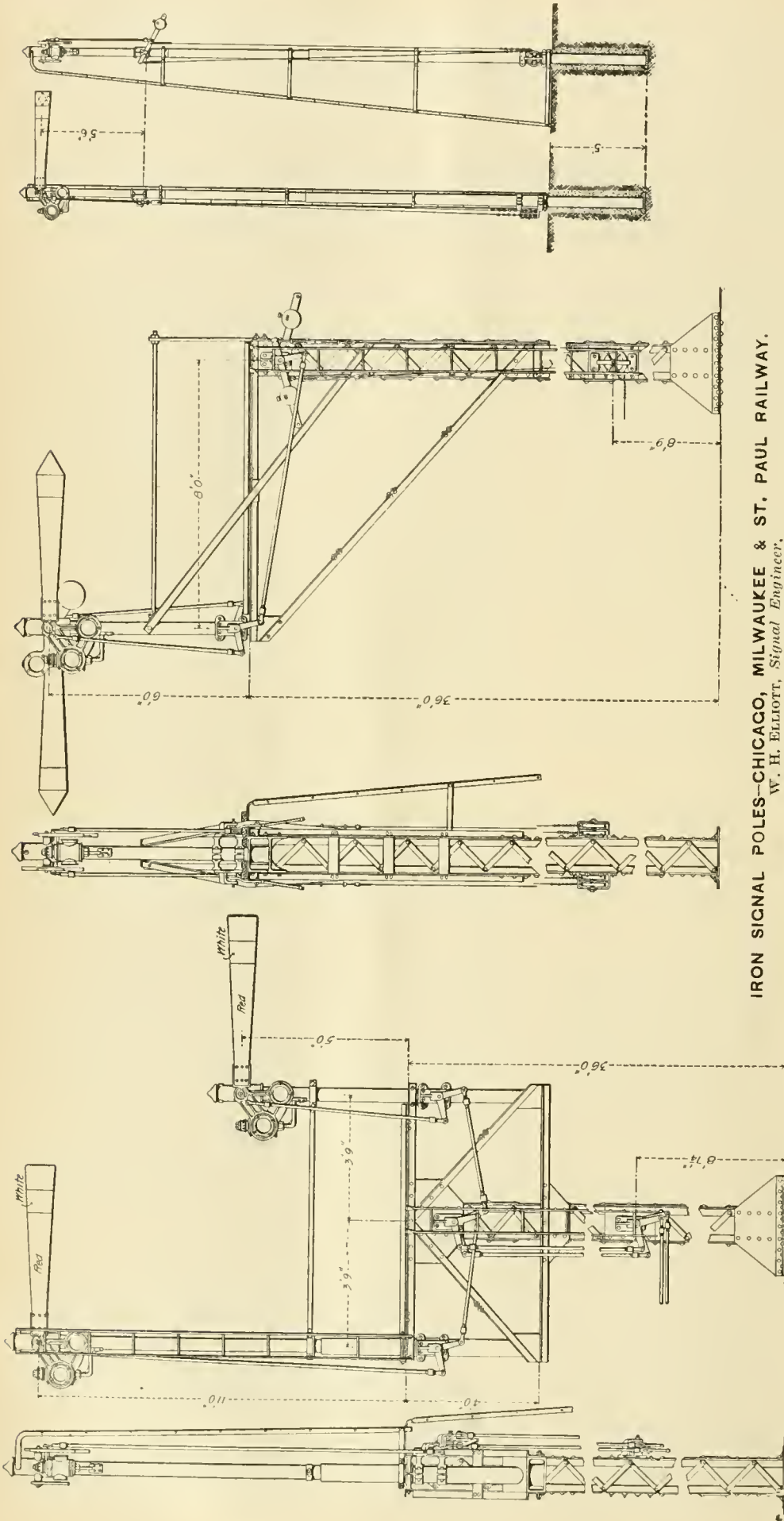

IRON SIGNAL POLES—CHICAGO, MILWAUKEE & ST. PAUL RAILWAY.
W. H. ELLIOTT, Signal Engineer.

IRON SIGNAL POLES ON THE
C., M. & ST. P. RY.

The large increase in the number of safety appliances introduced by the railroads of late years has resulted in a very great advance, not only in regard to certainty and precision of operation, but also in the matter of permanency of construction, with its resulting economy in the cost of maintenance. In no one direction can it be said to have advanced more than in the use of concrete and iron in substitution for wood. From a life of about six years, which is the average for wooden posts embedded in the ground, construction has advanced until now there is reason to believe that the probable life of the material used will be vastly increased. With most roads in this country signal work is of very recent date, so that the life of the material used was not considered as long as the desired stability of construction was secured. With the giving out of the wooden parts, however, and their comparatively short life the cost of keeping the work in good condition became manifest.

Among the first to advocate the giving up of wood, wherever other material could be conveniently used, was Mr. H. D. Miles, Signal Engineer of the Michigan Central Railroad, who read a paper on this subject before the Railway Signaling Club about two years ago, giving the results of his experience. While the roads have been rather slow in going into it, they have now progressed to such a point that the signal companies are prepared to furnish this class of work, and they are looking into the subject with the idea of making it their standard practice. The subject of iron poles in place of wood is now under consideration before the Signaling Club with a view to recommending standard dimensions so that uniformity of design may be secured. At present each road gets out its own designs and the ones here shown are adopted by the C., M. & St. P. Ry. as standard, having been prepared by Mr. W. H. Elliott, Signal Engineer of that road.

The drawings show the extreme simplicity of the design, the ease with which changes in connections can be made in the

field being readily seen. In place of the usual 10 by 10-inch wooden pole a pole made of 4, 5 and 6-inch pipe, having swedged joints 18 inches long, is used for the mast, one 32 feet long weighing but 550 pounds, and one 38 feet 660 pounds. The fittings, on which there is little machine work, are made to clamp the pole instead of screwing to it, the cap casting to which the ladder is fastened and through which the shaft to hold the arm plates is carried being slipped over the end of the pole and the joint filled with lead and calked, which gives an efficient yet easily made fastening.

It is on account of this fact of the easy method of fastening the different fittings to the pole that the cost of the 32-foot iron pole is brought down to about the cost of the same pole made of wood, for, while the pole itself costs one-third more than the wood, and the fittings for the iron pole are heavier, there is so little skilled labor required that the cost of fitting up is much less. For the 38-foot pole complete the cost is about \$4.00, or 10 per cent less than wood, so that not only is the first cost, but also economy of maintenance, in favor of the use of the iron pipe pole.

The poles after being set in the ground are packed in around the bottom with concrete to make a block about 12 inches square to give a stable base and support the pole without looseness in the ground. That this is large enough to hold the pole firmly in place has been clearly proved from the large number now in service, none of which have given any trouble in this respect. To prevent rusting at the top of the cement wherever possible the concrete is brought above the ground to give a good slope and cause the water to drain off. When erected the poles present a remarkably fine appearance and are quite an improvement on the wooden ones. They are painted white, the same as the wooden poles, and seem to be as easily seen.

In the design of the bracket and offset poles the novelty in the departure from the use of wood is really less than with the straight pole, as such work has generally been made of iron. Although the actual cost cannot be given, as none have as yet been completed, it can be stated from careful estimates that their cost will be but little more than that of wood. The built-up posts and cross-arms only, such as can be contracted for with bridge building firms, weigh for the bracket pole 2,000 pounds and for the offset pole 1,990 pounds, which, at 2.2 cents per pound, makes the cost of poles, without 4-inch pipe or fittings, \$44.00 and \$43.78 respectively.

As will be seen by an examination of the cut, the post is built up of four 2½ by 2½ by ¾ inch angles, the lacing being put on the outside and the post made straight so that the lacing strips will be of the same length and the rivet holes evenly spaced. For economy in construction none of the cross-arms or braces, with the exception of the two braces on the offset pole, are bent, the castings to hold the pipe posts being made wide enough to act as fillers and allow the several parts to be firmly bolted together. Using the same design of post for all bracket and offset poles, irrespective of the number of blades, reduces greatly the number of posts to be carried in stock, and with a few posts on hand almost any arrangement of signals may be readily secured by putting on the necessary fittings. These fittings are, for the most part, the same as those used on the pipe poles, or are of the common interlocking fittings, so that the parts necessary to fit up any kind of pole can be easily kept on hand. The matter of renewals in case of damage is also easily provided for, but few special pieces being required.

QUESTIONS ON TYPES OF WARSHIPS.

Mr. Charles H. Cramp, President of the Wm. Cramp & Sons, ship and engine builders, recently contributed the following views in regard to vital questions about warship construction, not yet settled, to the "New York Commercial:"

"The three cardinal points to be covered in a warship are offense, defense and sea-keeping power. The advantage of

speed for both the Spanish and our own navy was much impaired by the condition of the ships, all of which were much hampered by barnacles. The ships were foul, and none of them could probably make more than half of the speed which they made when they were fresh from the yards and with clean bottoms. The last battle (Santiago) has not settled the question of the battleship against the cruiser, for the reason that I have just mentioned, and for the further reason that American gunners were much the better marksmen.

"The thoroughly satisfactory way in which the turrets of the vessels engaged worked is a source of great satisfaction to me. The problem of the turret was an important factor to be demonstrated in its application to modern warships, and this naval action has settled that question. It is impossible to give an accurate opinion on the technical aspect of the case until full details are obtainable, but one thing seems clear and that is that the gun and the man who works it are the great factors in a naval engagement."

The torpedo boat question he regards as still open. Our navy has not had the opportunity to demonstrate what it can do with these boats, and the failure of the Spaniards to do effective work with their torpedo boats and torpedo boat destroyers is no indication, he thinks, that our men would make a like failure.

THE APPLICATION OF ELECTRICAL MOTORS TO MACHINE TOOLS.

Since 1892 the Mulhausen Grafenstadt-Belfort Engineering Company have given special attention to the problem of using electric motors for the driving of machine tools, and a series of tests was made to find the best arrangement for varying the speed while obtaining the maximum possible efficiency. After general remarks concerning the various speeds and gears required for different types of machine tools, the author proceeds to describe actual tests of three methods of transmission: 1. Disk and plate. 2. Sellers friction. 3. Belt of trapezoidal section. In the first section the following were tested: a, sole leather on cast iron; b, compressed paper on cast iron; c, lignum vitæ on cast iron; d, hardened steel on cast iron; e, and the Sellers disk with cast iron on gun metal.

The electric apparatus consisted of a shunt wound motor for 110 volts and 3 horse-power at 1,200 revolutions per minute, a voltmeter for 120 volts, an ampere meter to read up to 7 amperes and one to read up to 25 amperes, with switches and adjustable resistance. The mechanical apparatus consisted of a bed plate carrying two Sellers bearings carrying a shaft, upon which was fixed a pulley with a Prony brake, a speed counter pulley and a lever arrangement to measure the end pressure exerted upon the driving gear. The pulley of the Prony brake ran in a bath of soap and water. The whole apparatus was designed to enable the co-efficients of friction of the various transmission mechanisms to be readily obtained. The whole of the calculations are given at great length, and finally the results are collected in tabular form and the values are given for horse powers varying from 0.5 to 2.5. From these the following results for 2 horse-power may be selected as fairly typical:

E. H. P.	B. H. P.	Coefficient of friction.	Efficiency.
2.961	2.130	0.339	0.7193
2.761	2.113	0.420	0.7644
2.761	2.115	0.352	0.7688

{ Disk and roller, leather on cast iron.
 { Disk and roller, compressed paper on cast iron.
 { Disk and roller, lignum-vitæ on cast iron.

From the series of results given in the original the author concluded that the disk and roller are suitable, under certain conditions, for altering speeds for motors up to 2 horse-power.

With respect to Sellers disks, the author concludes that the efficiency is lower than that of the disk and roller, but that the apparatus may be used for small powers at speeds not exceeding 1,000 revolutions per minute. The experiments on the transmitting powers of leather belts of a trapezoidal or wedge section are compared with similar results obtained for ordinary flat leather belts. The belt groove has sides inclined to one another at 40 degrees. The belt speeds were 1,236, 2,472 and 4,944 feet per minute. With the apparatus in question it was not possible to obtain the co-efficient of friction for the belts, but it was clearly proved that their efficiency was far greater than those of the other methods already described. The author describes various forms of machine tools, and points out how much less room speed cones for wedge shaped belts take up than cones for ordinary belts.—Inst. C. E., Foreign Abstracts.

COMMUNICATIONS.

ADVANTAGES OF RELATIVELY SMALL GRATES.

Editor "American Engineer":

I was very much interested in a letter in regard to grate surface on page 260 of your August number. It carries out exactly what I have always held, and I believe I was the first to "preach" the question of grate surface in season and out of season. The Master Mechanics are all right when they call for large fire boxes to burn the bituminous coals, but the large fire boxes do not necessarily involve large grate surfaces. Some of the engines we are running now we have blocked up fully three feet in length of the grate surface, and are letting in an amount of air over the fire that would astonish the average Master Mechanic.

One engine which we have recently fitted up for lignite carried her train up a one per cent. grade with the fire box door open the whole time, showing that quantities of air could be used without cooling the flues.

C. M. HIGGINSON,

Assistant to President A., T. & S. Fe Ry.

Chicago, August 3, 1898.

THE GOVERNMENT AND THE METRIC SYSTEM.

Editor "American Engineer":

I have read the proof of Mr. Grafstrom's article entitled "A Chapter in Metrology" with much interest. In the main, I think his views are very reasonable, but I differ with him in his conclusion that the Government cannot at present properly take further steps in reference to the introduction of the metric system.

There is one very important step which is quite possible, and provision for which is made in a bill already before the Committee on Coinage, Weights and Measures in Congress. I refer to the official adoption of the metric system of weights and measures by the Government itself. I do not mean the simple adoption of the meter and kilogramme as final standards, which has already been accomplished; but I mean the official use of the metric system in the custom houses and in all other operations with which the Government has to do, except, as is provided in this bill, the office of Land Surveys, in which at present, at least, it would appear to be wise to continue the prevailing units. For several years the officers of the Government in the several bureaus which would be affected by such legislation have been practically unanimous in their desire to have the metric system adopted. All customs officers know that its adoption would be the means of preventing many annoying errors that are now continually made in the translation from the metric system to our own, and that it would greatly simplify all operations relating to importation, and undoubtedly create trade with metric-using nations. This step the Government might easily at any time take. It would do more, in my judgment, than anything else to bring the metric system to the attention of the general public, and would result in a very short time in a good degree of knowledge of the system on the part of the commercial public, together with a desire on their part to have the advantages of the improvement.

If this step were taken promptly, and at the same time efforts were made to secure instruction in the public schools of the country in the metric system and its use, I believe that its introduction would be general in the very near future. Many of our manufacturers are already using it; some of them are publishing catalogues of their products in which metric units are used, discovering, as they have, that it is necessary to do this in order to meet the demands of foreign trade. As Mr. Grafstrom says, the English have already found this out, and progress along the line of metrological reform is very active in Great Britain at the present time. It, therefore, does not seem at all impossible or improbable that with the adoption of the use of the system by the Government itself its final acceptance by the whole people may come sooner than many would imagine.

It is not impossible for the Government to follow the example of several European nations in making the system obligatory

after a certain period of years. I am very sure that, with the adaptability and quickness of comprehension of the American people, especially the American workmen and those who have to do with the smaller affairs in commerce, five or ten years' notice of the adoption of this system would be unnecessarily long. It must not be forgotten that in the earlier history of our country, when we were much less prepared to appreciate such advantages, the change was made from the English system of currency to our present decimal system with little or no difficulty. It has never been my idea that when the system was adopted by the Government all use of the ordinary units of weight and measure would immediately disappear. There would be no harm in and no legal obstacle to the continued use of pounds, feet and inches among those who desired to do so, just as there is now nothing to prevent any two persons doing business with each other in terms of the Chinese units of weight and measure if they so desire. In the history of our own money system it is well known that the older units were a long time in disappearing, but that now, after many years, they have practically gone. No one, I am sure, would desire to see their return. Something of this kind would be the result in the case of the adoption of the metric system by the United States Government, provided ample time was given for preparation.

T. C. MENDENHALL.

Office of the President.

Worcester Polytechnic Institute, Worcester, Mass., Aug. 15, 1898.

DRIVING AXLES AND CRANK PINS.

Editor "American Engineer":

I was much interested in Mr. Cole's presentation of the subject of "Strength of Driving Axles" in your June issue, but it seems to me that one point of considerable importance has not been referred to in this article. In the lower part of the right hand column on page 202, the bending strain upon the main axle is considered as being caused by the piston pressure divided by the number of driving axles, into the lever arm, or the distance between the centre of main rod bearing and centre of journal bearing. This is correct as long as the parallel rods are all well fitted and free from play or lost motion on the pin; but if there is any considerable amount of slack due to wear in the crank pin brasses of bushings, the conditions would be very much more severe for the main axle.

Let us consider, for instance, that there is a certain amount of slack in the main pin side rod bearing and possibly also in the other side rod bearings, but either will not make much difference in the following argument. When the side rods approach the dead center, the slack, of course, is behind the pin in reference to the direction in which the pin is moving, and as soon as the steam pressure comes upon the piston at the commencement of the stroke, there would be nothing back of the pin to help resist this load. We, therefore, see that at this instant the total bending moment on the axle will be due to the full pressure of the piston on the pin regardless of the number of coupled wheels on that side of the engine, and, therefore, the main axle will be called upon to resist a proportionately greater strain than under normal working conditions. If the axle and driving box are a neat fit, the conditions will be worse than if we consider them as having a certain amount of play which would enable the axle and driving box to move in the pedestal and help distribute the load through the parallel rods. Therefore, it seems to us that the condition is certainly likely to occur, as we know from experience that side rods will often be allowed to run with a good deal of lost motion, and this fact should certainly be considered in fixing upon the proper size and material of which to make the main axle.

The same thing refers in a less degree to the subject of crank pins treated in the May issue, whereby the slack or lost motion in the side rod causes the lengthening of the lever arm of the piston pressure, and we think there is sufficient importance in this matter to cause it to be considered when designing these parts of locomotives.

G. R. HENDERSON,
Mechanical Engineer.

Norfolk & Western Railway, Roanoke, Va.

[A proof of Mr. Henderson's communication was sent to Mr. Cole and we print his reply below.—Editor.]

Editor "American Engineer:

I am glad of the opportunity to answer the question Mr. Henderson asks in the above letter discussing the strength of driving axles.

It is often better to reason from known facts and base our conclusions upon them than to assume certain conditions which are not so clearly established. It seems more desirable to assume normal conditions for the working stresses, and keep the fiber stress at such a low figure as to give an ample margin of strength to resist the abnormal and extraordinary stresses which may occur from time to time.

In a locomotive having but one pair of drivers the entire piston thrust must evidently be resisted by the one crank pin and axle. The bending moment is the thrust of the piston multiplied by the lever arm; the maximum fiber stress caused by



Fig. 1.

this force is the bending moment divided by the modulus of section of the axle when worn out. If the tractive force exceeds the resistance caused by the adhesion of the wheels, slipping will take place. In ordinary types of engines having two or more pairs of drivers, the parallel rods transmit to the other pairs of wheels a proportional amount, so that each pair has to resist an equal turning moment. It is a generally accepted proposition that an equal force is transmitted to each pair, or that the maximum turning moment on any pair is equal to the piston thrust divided by the number of pairs of drivers. This fact being established, it follows that the parallel rod prevents the entire thrust being borne by the main axle and transmits it equally to all the drivers. If the lost motion is excessive, or if a lack of parallelism exists between the axles and the crank pins, slipping will take place at every revolution to adjust the irregularities. The stress on the main axle under these conditions will be increased up to the limit of adhesion, an excess amount probably not exceeding 25 or 30 per cent. of the normal stress.

When the crank is on the dead center the effect of lost motion in the rods or driving boxes is felt at its maximum. It is probable that ordinarily when there is much lost motion in the parallel rod bearings, the main axle will be also loose enough in its box to allow the load to be distributed among the drivers as at other portions of the stroke. There is also a certain amount of spring or deflection in the axle and crank pin, which occurs before the maximum stress is reached, and assists materially in equalizing the pressure between the drivers, taking up in a de-



Fig. 2.

gree the lost motion in the rod bearing. The possibility of overstrain in the main axle due to excessive slack in the parallel rod bearings, was carefully considered in the suggestion that the fiber stress should be decreased as the number of axles increases.

Mr. Henderson assumes that only the main axle is subjected to increased stresses due to excessive slack or improper adjustment, whereas, under certain conditions any of the other axles may be required to resist considerably more than their normal loading. Fig. 1 shows the crank pins of a consolidation engine at the commencement of the stroke, with an equal amount of slack in front of all the pins. This is the condition assumed by Mr. Henderson. It is evident, however, that a slight looseness in the main driving-box and spring in the pin and axle will in most cases prevent the entire piston thrust from being resisted by the main axle.

Fig. 2 shows the slack on the back of the main, second and fourth, and in front of the first pair. Here the first axle has to withstand an overload, unless relieved by looseness in the boxes or springing.

In Fig. 3 the slack is back of the main, first and second, and in front of the fourth pair, the latter axle having to withstand the overload.

Were it a fact that the working stress on the main axle of a consolidation engine should be taken as the entire piston thrust, irrespective of the number of axles, it could be shown by a number of instances of engines which have been in service for 15 or 20 years, during which time comparatively few breakages have occurred, in spite of the fact that the assumed stresses would figure up to 30,000 to 32,000 pounds per square inch for hammered iron axles, undergoing, roughly speaking, about 12 millions of repetitions of alternating loads per year.

The ability of wrought iron to resist repeated changes of loading is now so well known that it is unnecessary to go into details, but merely to state that breakages may always be expected to occur after a few million changes of load at from 16,000 to 25,000 pounds stress per square inch, the former being for reversing or alternating tension and compression, and the latter a load applied and entirely removed, but always acting in the same direction.

An axle under a freight locomotive is subjected to an alternating stress in which the reversals, although they do not reach the maximum yet when the engine is moving slowly and cutting off steam at, say, 80 per cent., do reach 50 or 60 per cent. of the maximum stress acting in the opposite direction. The breaking stress after two or three million repetitions could, therefore, reasonably be taken at about 20,000 pounds per square inch for good wrought iron. This is the breaking load for this range of stress as opposed to the static breaking load once applied, as seen in the testing machine, and known as the ultimate strength of the material, neither having any margin of strength or factor of safety, the latter breaking quickly with a single load steadily applied and not removed until after fracture, and the other breaking equally as surely, although not so quickly, after the required number of changes of load have taken place.



Fig. 3.

Again, the working stress of an axle can be approximately determined by the amount the rear axle of an eight-wheel engine can withstand, the parallel rod transmitting the force and the pin and axle being, therefore, entirely unsupported. Here instances can be cited where fractures usually occurred with iron axles when the stress exceeded 12,000 or 13,000 pounds. It seems unreasonable, therefore, to consider it necessary to design the main axle of a consolidation engine to resist the entire piston thrust unaided by the parallel rod, and keep the fiber stress down to, say, 8,000 to 10,000 pounds per square inch, figures which would usually be considered the maximum safe stress for this manner of loading. Taking the higher figure of 10,000 pounds, a mogul, consolidation or 10-wheel engine having 20-inch cylinders, steam pressure 200 pounds and a lever arm of 21 inches (center of main rod to center of frame), would require an axle of 11 inches diameter when worn down to the limit to resist the piston thrust alone.

For crank pins the support of the parallel rod was duly considered. On engines having the main rod outside it is comparatively small, so that the simplest method is to disregard it and use a higher working stress, as suggested in page 125 of the April number, and shown graphically in Fig. 6, page 154, of the June number. The distance from the wheel face to the center of the parallel rod is usually from 2 to 3 inches, making the counter-moment small in proportion to the bending moment, so that, after all, the real question is whether it is more desirable to use the higher stress without and the support of the parallel rod, or the lower stress, when it is taken into consideration. The latter seems to me the more rational, although more complicated, method.

Paterson, N. J.

F. J. COLE.

Pneumatic tubes for the transmission of mail between the New York and Brooklyn Postoffices were put into service Aug. 1. The tubes pass over the Brooklyn Bridge, and are provided with three expansion joints on the structure. The cost of the plant, including the double-pipe system, was \$60,000, and the annual rental paid to the New York Newspaper and Transportation Co. for carrying first-class matter is to be \$14,000 for a three-years' lease. The system is similar to that illustrated in our issue of November, 1897, page 379.

CONSOLIDATION LOCOMOTIVES—BURLINGTON & MISSOURI RIVER RAILROAD.

The Burlington & Missouri River Railroad has just received one of four consolidation engines recently designed and built by the Pittsburgh Locomotive and Car Works. They are for freight service in the Black Hills and it is expected that they will haul 50 per cent. more cars than the consolidation engines now in use there are handling on the limiting grades. The

Description.

Type.....	Consolidation
Number built.....	Four
Name of builder.....	Pittsburgh Locomotive Works
Gage.....	4 feet 8½ inches
Simple or compound.....	Simple
Kind of fuel to be used.....	Bituminous Coal
Weight on drivers.....	186,000 pounds
" truck wheels.....	15,200 pounds
" total.....	181,200 pounds
" tender loaded.....	94,200 pounds
Wheel base, total of engine.....	23 feet 6 inches
" driving.....	15 feet
" total (engine and tender).....	53 feet 2 inches

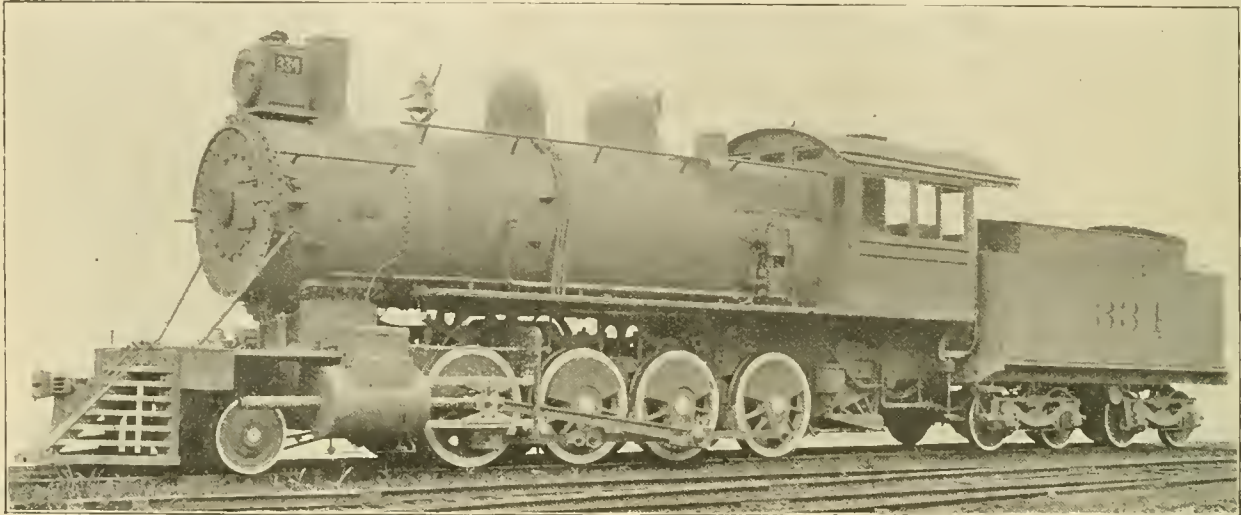

Consolidation Locomotive—Burlington & Missouri River Railroad.

PITTSBURGH LOCOMOTIVE WORKS, Builders.

new engines weigh 180,000 pounds and are heavier than any heretofore used on the Burlington and are among the heaviest ever built in weight upon drivers. Comparisons in regard to weight and leading dimensions, which may be made by aid of the table printed here and also that on page 1 of our January issue of this year, will be interesting.

The new Burlington engines have 22 by 28-inch cylinders and large boilers with the firebox above the frames and with unusually long tubes. While the heating surface has been exceeded in earlier designs, 2,675 square feet places the engine

Length over all, engine.....	40 feet 4¼ inches
" total, engine and tender.....	62 feet 7¼ inches
Height, center of boiler above rails.....	3 feet 9½ inches
of stack.....	15 feet
Heating surface, firebox.....	188.6 square feet
" tubes.....	2,486.4 square feet
" total.....	2,675 square feet
Grate area.....	31.6 square feet
Drivers, number.....	Eight
" diameter.....	52 inches
" material of centers.....	Cast-iron
Truck wheels, diameter.....	30 inches
Journals, driving axle, size.....	9 by 10 inches
" truck.....	5½ by 9 inches
Cylinders, diameter.....	22 inches
Piston, stroke.....	28 inches

TABLE OF COMPARISON OF HEAVY LOCOMOTIVES.

Builder and type { Railroad.....	Brooks, simple, Mexican Central.	Schenectady, compound, N. P. Ry.	Pittsburg, simple, B. & O. R. R.	Pittsburg, simple, D., M. & N. Ry.	Baldwin, simple, Buffalo & Susquehanna.	Schenectady, simple, D. & I. R. R. R.	Brooks, simple, Great Northern.	Simple, P. R. R. H-5.	Pittsburgh, simple, B. & M. R.
Total weight.....	193,450 lbs.	186,000 lbs.	168,000 lbs.	160,000 lbs.	163,550 lbs.	169,000 lbs.	212,750 lbs.	208,000 lbs.	181,200 lbs.
Weight on drivers.....	145,200 lbs.	150,000 lbs.	152,800 lbs.	144,000 lbs.	147,250 lbs.	139,000 lbs.	172,000 lbs.	186,000 lbs.	166,000 lbs.
Size of drivers.....	49 in.	55 in.	54 in.	50 in.	51 in.	54 in.	55 in.	56 in.	52 in.
" cylinder.....	21 x 26	23 x 34 x 30	22 x 28	22 x 28	22 x 26	22 x 26	21 x 34 in.	23½ x 28 in.	22 x 28 in.
H. S. firebox.....	218 sq. ft.	206 51 sq. ft.	183.64 sq. ft.	169.5 sq. ft.	189.5 sq. ft.	189.7 sq. ft.	235 sq. ft.	197 sq. ft.	188.6 sq. ft.
" total.....	2,805 sq. ft.	2,943.41 sq. ft.	2,315.64 sq. ft.	2,318.7 sq. ft.	2,244 sq. ft.	2,402.3 sq. ft.	3,280	2,721 sq. ft.	2,675 sq. ft.
Firebox.....	37¾ in. x 120 in.	42 in. x 120 ⅞ in.	41 in. x 115 in.	42¼ x 121 in.	42 x 121.8 in.	41¾ in. x 120 ⅞ in.	10 ft. 4 in. x 3 ft. 4½ in.	10 ft. x 40 in.	9 ft. 6 in. x 40 in.
Grate area.....	31.45 sq. ft.	35 sq. ft.	32.7 sq. ft.	35.5 sq. ft.	35.3 sq. ft.	34.5 sq. ft.	34 sq. ft.	33.3	31.6 sq. ft.
Steam pressure.....	180	200	180	160	180	180	210 lbs.	185 lbs.	180 lbs.
Size of boiler.....	78 in.	72 in.	64 in.	72 in.	72 in.	72 in.	78 in.	71 in.	74 in.
Kind.....	Belpaire.	Extended wagon top, Radial.	Extended wagon top, Radial.	Straight.	Straight.	Straight.	Belpaire.	Belpaire.	Belpaire.
Staying.....				Radial.	Radial.	Radial.			
Tubes.....	412, 2 in. diam. x 12 ft. 1¼ in.	332, 3¼ in. dia. x 11 ft.	246, 2¼ x 14 ft. 8½ in.	272, 2¼ x 13 ft. 6 in.	260, 2¼ x 13 ft. 6 in.	280, 2¼ x 13 ft. 6 in.	376, 2¼ in. dia. x 13 ft. 10¾ in.	306, 2¼ in. x 14 ft.	292, 2¼ in. x 14 ft. 6½ in.

among the largest in this respect. In considering the weight of the engine it should be noted that all but 15,200 pounds comes upon the driving wheels for useful adhesion. Among the noticeable features shown by the photograph are extended piston rods, a comparatively short front end, a separate dome for safety valves and whistle, alligator crossheads, automatic couplers. These engines have been built under the direction of Mr. G. W. Rhodes, Superintendent of Motive Power, Chicago, Burlington & Quincy Railroad.

The following table gives the leading dimensions:

Valves.....	Richardson Balance
" greatest travel.....	5 inches
" outside lap.....	¾ inch
Boiler, type of.....	Belpaire
" working steam pressure.....	180 pounds
" material in barrel.....	Steel
" diameter of barrel.....	74 inches
Firebox, length.....	9 feet 6 inches
" width.....	3 feet 4 inches
Tubes, number.....	292
" outside diameter.....	2¼ inches
" length over sheets.....	14 feet 6½ inches
Tender.	
Tank capacity for water.....	5,000 gallons
Coal capacity.....	17,500 pounds
Type of truck spring.....	Semi-Elliptic

Diameter of truck wheels.....	37 inches
Diameter and length of axle journals.....	4 1/4 by 8 inches
Distance between centers of journals.....	6 feet 3 inches
Diameter of wheel fit on axle.....	3 3/8 inches
Diameter of center of axle.....	4 3/8 inches
Length of tender frame over bumpers.....	22 feet 3 1/2 inches
Length of tank.....	19 feet
Width of tank.....	9 feet 6 inches
Type of back drawhead.....	M. C. B. Coupler

MECHANICAL DRAFT.*

By W. B. Snow.

The substitution of the fan for the chimney as a means of draft production marks a distinct advance in the convenience and economy of steam generation.

Mechanical draft may, in stationary practice, be applied in either of two ways: First, by forcing the air into a closed ashpit, and maintaining therein a pressure in excess of the atmosphere; and second, by exhausting the air and gases from the flue or uptake and thereby creating a partial vacuum, which causes a constant inward flow of air in the combustion chamber. The former is designated as "forced draft" and the latter as "induced draft." Under certain conditions a combination of the two methods may be found desirable. The natural result of the application of a centrifugal fan in either manner is to render the draft conditions positive at all times. A fan of the disc or propeller type is entirely inadequate for such work.

On the erection of a chimney the first matter to receive con-

means of a chimney. The economic value of this and the preceding features of convenience will be considered as we proceed.

We may now turn to the distinctly economic aspects of the installation of mechanical draft, and of necessity these must be considered relatively to those incident to the use of a chimney. Employed solely as a means of creating air movement the chimney is most absurdly inefficient. It may be readily shown that under the ordinary conditions of boiler practice an engine-driven fan will move a given amount of air with the expenditure of about one-seventy-fifth as much power. This immense advantage of the fan over the chimney may be turned to good account by introducing proper devices for transferring the heat of the gases to the feed-water or to the air supplied to the fire, and the gases may, with fan draft, be cooled to a temperature far below that which could be attained with a chimney without too seriously reducing its draft. Tests of blue large boiler plants equipped with economizers and mechanical draft are reported by Roney to have shown on an average a saving of about 14 per cent. In connection with a plant of such size the steam required for the operation of the fan, with an efficient engine, can be kept within 1 per cent. of that generated by the boilers to which it is applied.

Custom and the expense of high chimneys are, doubtless, responsible for the comparatively low combustion rates which prevail in most steam plants. It may be fairly stated that to double the rate of combustion on a given grate area, it is necessary to make the chimney about three times as high, at a cost

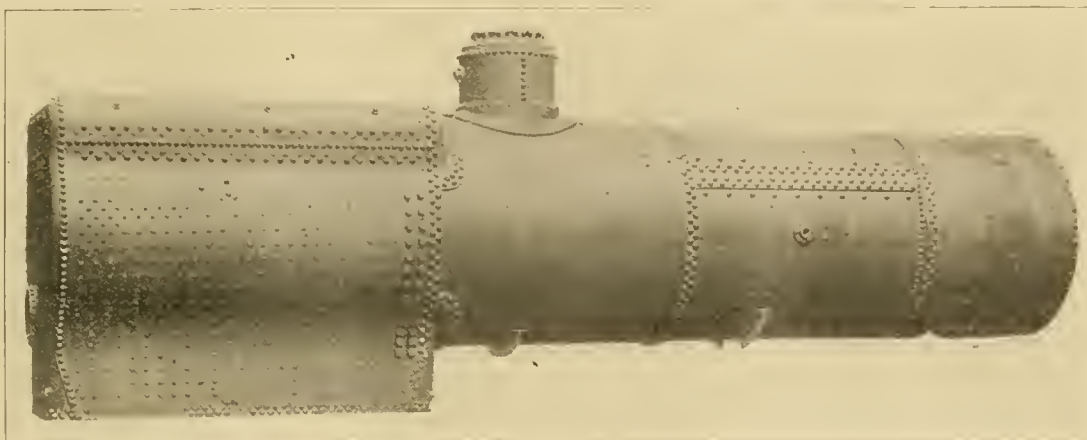

Boiler of Consolidation Locomotive—B. & M. R. R. R.

sideration is the foundation. This always represents a comparatively large, and in the case of unstable ground an abnormally excessive proportion of the expense of the entire structure. A fan, on the other hand, is relatively light, requires no expensive foundation, and may in many cases be located upon the top of the boilers.

The portable character of a mechanical draft apparatus renders it not only valuable as an available asset, when it is no longer required in a given location, but makes possible its relocation or arrangement in a manner that is absolutely impossible in the case of a chimney, which must always stand as a monument to a departed industry or an abandoned means of draft production.

The primary duty of the chimney is to create sufficient draft, while its secondary office is to remove the gases and smoke to a proper height for discharge to the atmosphere. The height required for this purpose is almost universally less than that necessary to produce the draft. Obviously a stack of decreased height and cost will serve the purpose with mechanical draft. In fact, a sheet iron pipe extending but a few feet above the top of the boiler house will in most cases fulfill the requirements.

The steel plate construction which is common to most fans employed for producing draft makes it possible to readily design and build them to exactly suit any given conditions. Such a fan may be arranged to be driven by a belt or by a direct-connected engine, as may be desired, may be automatically controlled in its speed to meet the requirements of steam generation, and may be increased in capacity by the simple transmission of more power.

Another feature of convenience resulting from the employment of mechanical draft is to be found in the ability to burn cheap fuels which are almost invariably of small size and require an intensity of draft which is not readily created by

perhaps five times as great. In the case of a fan the same result could be obtained without even so much as doubling the cost. This clearly points to the economy to be secured by properly designing the boilers, increasing the combustion rate and securing a greater output from a given size boiler and for a stated investment. Low combustion and evaporation rates are not essential to high efficiency. Within reasonable limits the higher the rate of combustion, the less is the volume of air required per pound of coal. The fire is of necessity deeper, the draft is stronger, and each individual particle of air has increased opportunity to come in contact with the fuel. With a decreased supply of air the intensity of the fire is increased, its temperature is higher, more heat is radiated to the exposed boiler surfaces and more is taken up by the gases, which, because of less ultimate volume, move at lower velocity and thus have more time to part with their heat. As regards the economy of evaporation, F. R. Low has shown that in the case of thirty Babcock & Wheeler boilers practically as good results were obtained at a rate of 5 pounds per square foot of heating surface as at the rate of 1.75 pounds.

When a fan is employed as a means of draft production it may, at comparatively small expense, be installed of such size as to possess an emergency capacity which, if embodied in the boilers, could only be provided at vastly greater first cost, with incident larger fixed charges.

In order that a definite comparison may be made between the two methods of draft production, a certain 1,600 horsepower plant has been taken, of which the cost is known. This consists of eight modern water-tube boilers, two economizers and a chimney 8 feet in diameter by 180 feet high. The latter is located just outside the boiler house wall. If a duplex induced mechanical draft apparatus, each fan capable of operating the entire plant, should be substituted for the chimney, it could be placed immediately above the economizers, and with its attached engine could be rigidly supported by beams resting on the economizer walls. A short stack would serve to discharge the gases above the roof.

* From a paper presented before the Northwestern Electrical Association, June, 1898.

The cost of the chimney, with damper regulator and dampers, is \$9,300; that of fans, engines, draft regulation and short stack, installed complete, would be about \$3,500, or only 38 per cent. of the draft producing apparatus for which it is substituted. That is, the saving would be \$5,800.

With the increased draft produced by the fans it would be possible to raise the combustion rate and the steaming capacity, or what is equivalent, the steam capacity might be maintained with a less number of boilers. Suppose one of the eight boilers be omitted from the original design, making the plant 1,400 nominal horse-power, a further saving of about \$4,000 may thus be secured.

If the land be valuable, the reduction of space incident to the employment of mechanical draft may have an appreciable effect. If worth—say \$2 per square foot, the saving by omission of chimney and one boiler would be about \$2,000. The total saving in first cost resulting from an expenditure of \$3,500 for mechanical draft may thus be shown to be \$11,800; that is, the saving is nearly three and a half times the expenditure necessary to secure it. Obviously, there is a coincident reduction in the fixed charges for interest and taxes.

The power expenditure for operating the fans should be practically inappreciable in any well-designed plant in which provision is made to utilize the exhaust steam from the fan engine.

The most direct saving in operating expense which may be secured by the introduction of mechanical draft is that resulting from the utilization of cheaper fuel. Such a plant as previously described would, under good conditions, probably, require at least 8,000 tons per day. If a saving of only 25 cents per ton could be effected it would represent an aggregate of \$2,000 per year, a pretty good return on an investment of \$3,500. But in many cases much greater savings may be brought about. A case in point is that of the United States Cotton Company, at Central Falls, R. I., where, with a 1,000 horse-power boiler plant, the fuel originally employed chimney draft was George's Creek, Cumberland, costing \$4 per ton. With forced draft, a mixture of No. 2 buckwheat screenings and Cumberland is now used, costing \$2.62 per ton. The saving has been about \$125 per week, enough to pay for the special steam fan in about six weeks.

IMPORTANCE OF KNOWING COSTS OF SHOP OPERATIONS.

In the discussions which have been held during the past few years upon the subject of improving shop organization one feature stands out boldly as a fundamental principle, and yet its real importance does not appear to have been generally recognized. This is the importance of knowing present costs as a basis upon which to build improved methods. In his paper before the Western Railway Club, published in our November issue, 1897, Mr. L. L. Smith says of the railroad officer: "In order that he may intelligently devise ways and means for the reduction of the cost of work, he must first determine what the work is actually costing under existing conditions. By being armed with this information he is not obliged to deal and argue entirely in generalities. This information is of great value alike to the superintendent of motive power, the master mechanic and the foreman. The importance of knowing what work costs cannot be too strongly emphasized. The piecework principle is the embodiment of this idea, but even the most ardent opponent of the piecework plan cannot consistently object to determining what his work is costing."

The piecework plan often fails, and it is not too much to say that it is predestined to failure when it is not based upon accurate knowledge of the cost of work. It is necessary to add somewhat to the clerical force in order to keep track of the cost, and if the financial advantage of doing this was appreciated the small expense would surely not be an obstacle. Mr. Fred W. Taylor spoke with authority when he said before the American Society of Mechanical Engineers in 1895: "How few of them (manufacturers) realize that, by the employment of an extra clerk and foreman, and a simple system of labor returns, to record the performance and readjust the wages of their men, so as to stimulate their personal ambition, the output of a gang of twenty or thirty men can be readily doubled in many cases, and at a comparatively slight increase of wages per capita."

This authority also says that the most formidable obstacle in

carrying out a piecework system is the lack of knowledge on the part of both the men and the management, but chiefly the latter, of the quickest time in which each piece of work can be done; or briefly, the lack of accurate time tables for the work of the place.

The way to remedy this trouble is to place the matter of prices in the hands of an individual or a department having the necessary experience, information and authority to establish the prices upon a basis which shall be an incentive to the men and at the same time shall be fair to the employer, and shall not require adjustment until some new method or process brings a new element into the work to change its cost. Not the least value of Mr. Smith's paper is the description given whereby it is clearly shown that the Chicago, Burlington & Quincy Railroad officers correctly estimate the piecework system, and that a specialist has been appointed to establish it.

The great number of important duties devolving to-day on a Master Mechanic renders it unreasonable to expect him to look after details requiring such careful study as must be given to such subjects. This work requires the undivided attention of an expert, who must familiarize himself with all of its details. The work of busy railroads requires more and more specialization, and nowhere is the necessity for a specialist seen more clearly than in this matter of prices, when it is considered that conditions are different at the different shops of the same road.

Writing in the "American Machinist" several years ago Mr. W. O. Webber said: "It is surprising how much can be done by one smart young man who has some experience himself in shop work, in discovering and plugging up the leaks in a machine shop, by taking the time slips from each man and playing a sort of game of solitaire with them to determine the exact value of the different manipulations." He also remarks upon the surprising interest which foremen, if they are interested at all in their work, take in these figures and try to find remedies for defects.

A reason offered by officers who do not favor piecework is that some have tried it and have failed to secure reduced cost of work. This is not the fault of piecework, but of the men who establish the prices, and it supports the opinion that the root of the whole matter is the accurate knowledge of the cost of each operation.

Reference has been made to the differences in costs in different shops of the same road. There are reasons why differences of results will exist on roads that are long enough to pass through sections of the country so widely separated as to introduce different scales of prices at the different shops. The fact is well known, however, that the variation of wages will not account for all of the differences, and much may be accomplished by closely comparing the work of different shops after taking the wages into account. The frequent meetings of the officers for discussion of practice is now recognized as a necessary factor in railroad work, and whether it be among superintendents of divisions, officers of bridge departments, master mechanics or master car builders, the comparison of the cost of the work done by each is as important a subject as may be found, and in the order of important duties it should be placed next to those which have to do with safety of operation.

A new six-inch rapid-fire wire-wound naval gun has been adopted by the English Navy. The tests, which were very thorough, show that the gun may be fired at the rate of one round in eight seconds and after 200 rounds the accuracy of fire was not affected. A velocity of 2,780 feet per second pressure of 15.9 tons and striking energy of 5,374 foot tons have been obtained. The breech is opened and closed by a single motion and the primer tube is automatically covered until the breech plug is locked. The gun does not require cartridge cases, which is a favorable feature, owing to their weight in the magazines and the usual complication necessary to eject the empty case from the breech of the gun.

FREIGHT TRUCK, CAST STEEL TRUCK AND BODY BOLSTERS—SEABOARD AIR LINE.

Through the courtesy of Mr. W. T. Reed, Superintendent of Motive Power of the Seaboard Air Line, we have received the drawings of a freight truck for 60,000 to 80,000 pound capacity cars, which are reproduced in the accompanying engravings. The older trucks with sandwich bolsters, which the present design replaces, had a total of 114 pieces, including everything from the center plates to the wheels, whereas the one illustrated has only 83.

The truck is of the arch bar type, with cast steel end castings, which combine the column guides and spring seats in a single piece fitting neatly over the ends of the bolster, with the column bolts passing through the arch bars to form an excellent arrangement for maintaining the alignment of the truck. In-

outline the cars (not even excepting wrecks), and state that when the capacities of the cars are increased in the natural course of progress, the trucks, which are the most expensive parts of the cars, will be ready to receive new bodies of greater capacity, with only an increase of the size of the axles.

Our drawings show the construction of the trucks so clearly as to require no further explanation, but we will quote from a letter received from Mr. Reed, as follows:

"The idea of applying such bolsters to freight cars is to dispense with the many parts which require additional labor on trucks used previously of the same pattern as far as the arch bars were concerned, with flitch plate bolsters. . . . The time has now arrived when mechanics can readily see the advantages to be gained in the minimum number of pieces in any part of a truck or other machinery, and it is to this end that I find it most advantageous. What we need is a truck that

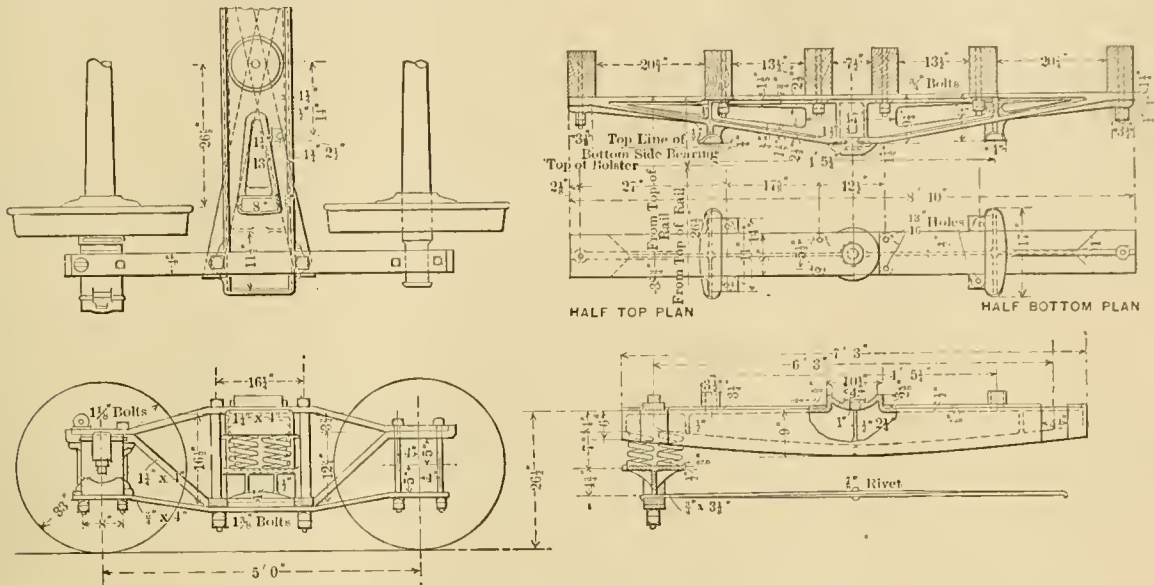

New Standard Truck and Body Bolsters—Seaboard Air Line.
BY THE AMERICAN STEEL FOUNDRY CO.

stead of a spring plank, which in this arrangement is unnecessary, lateral bracing is provided by two diagonal bars of $\frac{3}{4}$ by $3\frac{1}{2}$ -inch iron, crossing at the center, where they are riveted together. The truck and body bolsters are of solid cast steel, which together with the end castings were furnished by the American Steel Foundry Co. of St. Louis. The truck bolster combines the center and side bearings, brake hanger and guide lugs in a single piece, greatly reducing the number of pieces. The body bolster, the construction of which is clearly indicated in the drawing, is also cast in one piece, carrying out this idea still further.

The great importance of keeping the side bearings clear of each other was shown by the remarks of Mr. A. E. Mitchell at the recent convention of the Master Car Builders' Association. It was also shown in a recent discussion before the Western Railway Club, a report of which will be found elsewhere in this issue. It is evident that it is not sufficient to have one of a pair of bolsters of the requisite stiffness, but both the body and the truck bolster must be so designed as to hold the loads without allowing the side bearings to come into contact. The truck and the body bolster are intended to have corresponding capacities, which are so far above the requirements of cars of this size as to positively insure against permanent set. The object is to fulfill the conditions that the Master Car Builders are seeking to provide for, namely, to carry the loads on the center plates.

While the stated capacity of these cars is 60,000 pounds, the manufacturers of the bolsters guarantee them for 80,000 pounds, and base a strong claim for economy on their ability to carry the heavier loads. They guarantee the bolsters to

will stand all abuses possible after derailments, so that the trucks may be replaced on the tracks and continue their journey while others must be taken apart. We have several of these trucks in fast freight service, and have no reason to complain of their standing up under from 60,000 to 80,000 and 100,000 pounds."

AXLES FOR HEAVY CARS.

The present tendency toward the use of cars of capacities greater than 80,000 pounds renders it advisable that the Master Car Builders' Association should take steps toward the establishment of a standard axle which shall have greater carrying capacity than the heaviest which has so far received the attention of the association, viz., the 80,000-pound axle, and the subject was introduced by Mr. E. D. Nelson at the 1898 convention in a letter, which we think important enough to reproduce nearly in full, as follows:

The Committee on Subjects for 1898 included in their report a topical discussion of the question of an axle for 100,000 pounds capacity cars, and a revision of the axle for 60,000 pounds capacity cars. In regard to the axle for cars of 100,000 pounds capacity there are now being built by one railroad company of which I have knowledge 1,000 cars of 100,000 pounds capacity, and I think that there is one other railroad which has in use about an equivalent number of cars of this same capacity. It has occurred to me that it would be well for the Master Car Builders' Association, as early as possible, to settle upon a design for an axle for these cars. I have therefore taken the liberty of designing an axle for a 100,000 pounds capacity car. In designing the axle for a car of 100,000 pounds capacity the method outlined in the report of the Committee on Axle, Jour-

nal Box Bearing and Wedge for cars of 80,000 pounds capacity, made to the convention of 1896, has been followed:

The data are as follows:

Weight of body and trucks.....	40,200 lbs.
Weight of lading.....	100,000 lbs.
20 per cent, additional lading.....	20,000 lbs.
Total.....	160,200 lbs.
Deduct weight of eight 33-in. wheels.....	5,000 lbs.
Weight of four axles.....	3,200 lbs.
Total.....	8,200 lbs.
Total weight on four axles.....	152,000 lbs.
Static load on one axle.....	38,000 lbs.

In order to find the point at which the load must be considered as acting on the journals it is first necessary to consider the dimensions of the latter:

The Master Car Builders' journal for 40,000-pound cars is 7 inches long, for 60,000-pound cars 8 inches long, for 80,000-pound cars 9 inches long. It might, therefore, be assumed that for cars of 100,000 pounds capacity the journal should be 10 inches long.

We can suppose, for the purpose of maximum conditions of wear, that the collar of the journal should be worn off 1/2 inch in thickness from contact with the bearing, and the bearing worn off 3/4 inch on the end next to the collar. The journal would then be 10 1/2 inches long, and the bearing surface on the journal would be 8 3/4 inches long. This would throw the center of bearing surface 1 3/8 inches outside of the normal center line of journal.

Referring to Fig. 6, page 167 of the Proceedings of 1896, the lever arm T would be, therefore, equal to 6 3/8 inches; and assuming this lever arm 1/2 inch greater on account of the dust guard seat being reduced 1/2 inch in length, it would make the value of T 6 7/8 inches.

By substituting in formula 12, page 153, and calculating the

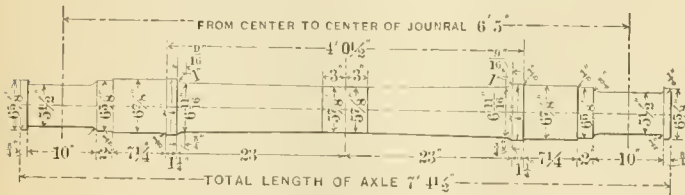

NOTE.

NORMAL WEIGHT OF AXLES 788 LBS.
AXLES MUST NOT EXCEED 808 LBS.

Axle for 100,000 Lbs. Capacity Cars.

moment from the above dimensions, we find the diameter of the journal to be 4.98 inches. Taking the nearest eighth of an inch above this theoretical diameter would make the journal 5 inches; and allowing 1/2 inch for wear would make it 5 1/2 inches.

Assuming the journal, therefore, to be 5 1/2 by 10 inches, it is found that, so far as friction and lubrication are concerned, we have the following data, in connection with page 169 of the Proceedings of 1896:

4 1/4 x 8 journal, new; pressure per square inch.....	449 lbs.
5 x 9 journal, new; pressure per square inch.....	469 lbs.
5 1/2 x 10 journal, new, pressure per square inch.....	470 lbs.
4 1/4 x 8 journal, worn to limit of 3/4 in.....	533 lbs.
5 x 9 journal, worn to limit of 4/2 in.....	625 lbs.
5 1/2 x 10 journal; worn to limit of 5 in.....	516 lbs.

These figures would indicate that the size of journal from the standpoint of friction and lubrication is all that need be desired.

It is now only necessary to arrive at the design of axle between wheels, and, assuming the point of concentration of load the same as that selected above for calculating the diameter of the journal, and applying the figures for weight as previously assumed, the theoretical diameters of the vital points of the axle between the wheels are as follows:

- Wheel seat, 6.70 inch.
- Center, 5.73 inch.

Taking the nearest eighth of an inch above these figures, and allowing 1/8 inch on wheel seat for reduction of same, we have for diameter of wheel seat 6 7/8 inches, and for center 5 7/8 inches.

The nearest eighth of an inch above the theoretical diameter at center given above would actually be 5 3/4 inches; but by making the center of the axles straight for 6 inches, which is considered desirable, it is necessary to increase this diameter in order that the straight portion of the axle at the center may not intersect the tapered portion at a point which would give a diameter less for that particular point than the theoretical diameter.

The assumptions for fiber stress have been taken at 22,000 pounds per square inch for that portion of the axle between the wheels, and 10,000 pounds per square inch for strength of

journal; and the actual fiber stress based on the dimensions given above is safely within these limits.

In regard to the revision of design of axle for 60,000 pounds capacity cars, it will be noted on page 183 of the Proceedings of 1896, that the Master Car Builders' axle, with 4 1/4 by 8 inch journals, has a fiber stress at the hub, when reduced 1-16 inch in diameter, of 24,030 pounds; at the center of 22,452 pounds; and it was with the idea of making this axle somewhat larger at the hub and slightly larger at the center that we suggested that the present design be revised. This would not involve any changes affecting the interchangeability of these axles in freight cars.

BENDING TESTS OF LOCOMOTIVE STAY-BOLTS.*

By Francis J. Cole.

No parts of a locomotive require so careful and systematic inspection, to maintain them in a safe working condition, as the stay-bolts.

Speaking generally, their life, that is, the interval which elapses from the time the boiler was new or the stay renewed to their fracture, varies from about one to five years or longer. Probably the average would not exceed five years on all classes of engines. This depends, however, upon the length and height of fire-box, steam pressure, size of boiler, width of grate, etc.

The stay-bolts in a boiler of large diameter, with the fire-box between the frames and small curves or radii connecting the circular portion with the vertical sheets of the fire-box shell, may always be expected to have a shorter life than in a boiler of the same length of grate, but of small diameter, with the fire-box on top of the frames.

As modern requirements demand large boilers, high steam pressures, long fire-boxes, etc., in short, the very conditions which ought not to exist if the stay-bolt alone were considered, their life may reasonably be expected to be shorter than in the past, owing to the construction necessary for heavier, more powerful and economical engines.

The stress on a stay-bolt produced directly by the steam pressure, tending to force the two sheets apart, is a comparatively small factor in causing its fracture, the tensile stress alone being only 1/8 to 1-10 of the ultimate strength, which, if not complicated by the expansion and contraction of the fire-box, causing bending in addition, would in itself never produce a fracture. It follows, then, that the property of a metal to

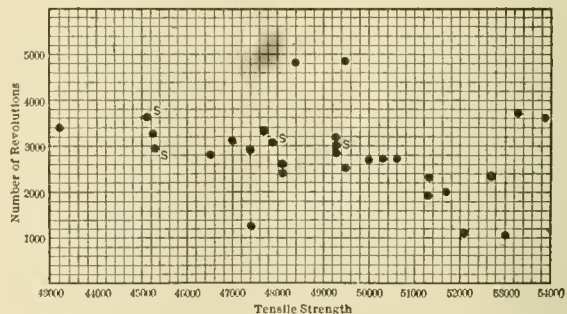

resist repeated bendings is more valuable than its strength to resist extension or fracture in the direction of its length.

Following out this general idea that stay-bolt iron should be tested for bending under uniform conditions of motion and rigidity with the usual tests for ultimate strength, elongation and elastic limit, a number of different makes of iron were tested on a machine especially designed for the purpose. These tests were made by the writer about three years ago.

In designing the machine two features were kept prominently in view; viz., to make the machine rigid and to clamp the specimen so tightly that no motion would take place in the fixed end, and at the same time to strain it by tension in imitation of the stress produced by the steam pressure.

Its construction is so clearly shown in the drawing that an extended description will be unnecessary.

Although the machine is arranged to test pieces 3, 6 and 9 inches in length, the tests were all made with a uniform length of 6 inches, measured from the center of the bolt to the face of the hardened steel die, on account of the difficulty experienced in obtaining any reliable spring pressure with the bolt shorter than 6 inches. The liner used in the machine for all specimens was 1-16-inch thick, making the free end of the stay-bolt describe a circle 1/8-inch in diameter. Great care

*From a paper read at the Niagara Falls meeting (June, 1898) of the American Society of Mechanical Engineers.

was taken to clamp the bolt so securely in the machine that the movement of the projecting end was scarcely appreciable.

The spring pressure used in all cases was 2,400 pounds, corresponding to the strain exerted by the steam pressure in a boiler where the stay-bolts are spaced 4 inches center to center, with a steam pressure of 150 pounds per square inch.

It is clearly shown, I think, by these tests, that the principle of the machine is correct, and that the solid durable manner in which it is designed eliminates most of the variables which have hitherto made these bending tests of but little value. The average general results which the different

2,400 pounds, the stress per square inch of section on the different diameters of reduced bolts:

Size, inch.	Area.	Stress, pounds.
1	.7854	3,050
$\frac{1\frac{1}{8}}$.6913	3,175
$\frac{1\frac{1}{4}}$.6013	3,360
$\frac{1\frac{3}{8}}$.5185	4,630
$\frac{1\frac{1}{2}}$.4418	5,430
$\frac{1\frac{3}{4}}$.3712	6,465
$\frac{1\frac{7}{8}}$.3068	7,820
$\frac{1\frac{7}{16}}$.2485	9,658
$\frac{1\frac{1}{2}}$.1963	12,226

After experimenting with the $\frac{7}{8}$ -inch bolt reduced to the different diameters, it seemed plausible that by increasing the

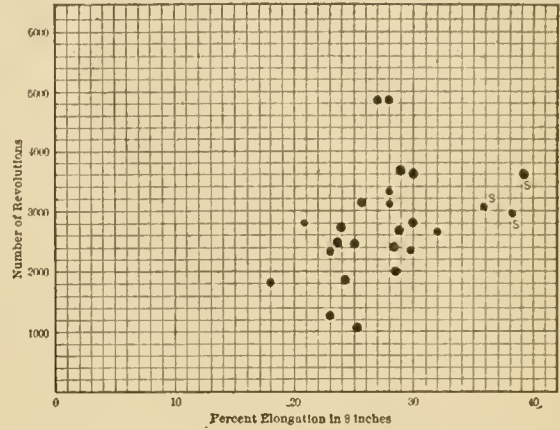
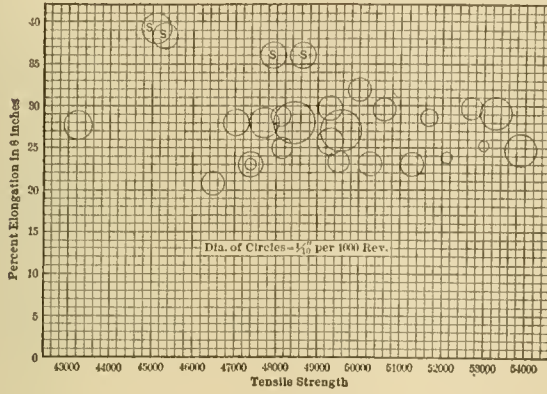

qualities of iron gave, followed closely the quality and value of iron for actual service. The imitation by the machine of the strains produced in a stay-bolt, when screwed in a boiler, is very close, and while some of the tests of the same bar show a larger percentage of difference than in the tensile tests of the iron, yet this is probably accounted for by the fact that in case the threads were cut sharper, or any flaw existed in the iron, its effect would be very much more marked and exaggerated than would be shown by an ordinary tensile test.

diameter to 1 inch, and then reducing the section, that a marked improvement might be made. This, however, did not seem to prolong the life to any great extent.

The approximate cost of renewing stay-bolts, a few at a time, is as follows:

Cutting out one broken $\frac{7}{8}$ -inch stay-bolt, re-tapping holes, and putting in new bolt18 cents.
Riveting up two ends.....	2 "
Total cost of renewing stay-bolt.....	20 cents.

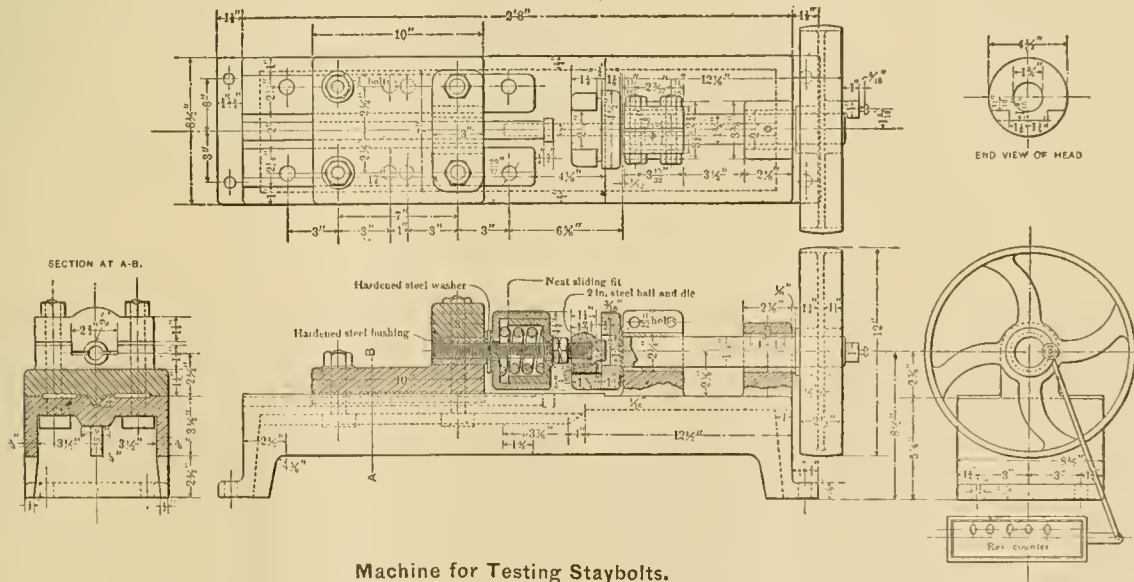

Machine for Testing Staybolts.

While the individual tests of specimens cut from the same bar are somewhat erratic in a few instances, yet the average of the tests cut from the same bar seems to follow some well defined law.

Cutting off the threads and reducing the size of the middle of the specimen does not in these tests indicate a sufficient degree of improvement in prolonging the life of the stay-bolt to warrant the extra expense. It appears that after a bolt is reduced and turned down a sufficient amount to equalize the strain, and to distribute it over a considerable portion of its free length, the stress produced by the pressure of the spring runs up to such an extent, per square inch of section, that the combination of bending and extension stresses exercises a marked influence in shortening the life of the bolt.

The table given below indicates for a uniform pressure of

This does not include taking down or putting up any parts of machinery which may be in the way of renewing the stay-bolt. In round figures the minimum cost for labor for renewing stay-bolts in small numbers would be 15 cents per pound. This is for the simplest cases; if there is any machinery or part to be removed, the cost would be greatly increased. Inasmuch as the cost of labor alone for renewals is nearly three times the cost of the highest-priced stay-bolt iron, it would be economical to use a special stay-bolt iron possessing the necessary properties to resist repeated bendings.

The results of the tests are plotted in the diagrams. A careful study of these show that the best results were obtained from an iron having an ultimate strength of 48,000 to 49,500 pounds, with an elongation of 28 to 30 per cent. in 8 inches.

If it were possible to make the stay-bolts of sufficient length to allow for the maximum movement of the fire-box, so

as to bend them within their elastic limit, without producing a permanent set, their life would be increased to a remarkable extent.

Let X represent this movement at a distance Y, it is evident, then, that if the length, Y, is decreased, the bending movement will be increased so that fracture will occur with a smaller number of movements. With a constant amount of movement, the decrease of length can so intensify the bendings stress that fracture will occur after a few thousand repetitions of the force, produced by the expansion and contraction of the boiler.

THE DE LAVAL HIGH-PRESSURE STEAM BOILER AND TURBINE.

The high-pressure steam boiler designed by Dr. de Laval and installed at the Stockholm Exposition in connection with the exhibit of steam turbines was interesting, in that it involved high pressures under commercial conditions. The application has not been clearly shown previous to its publication in the "Ternisk Tidskrift," and we are indebted to the "Iron Age" for the following translation of the description and the drawing.

The boiler A consists of a single long pipe of small diameter, bent in cylindrical spirals, A¹, between which the products of combustion pass, generating steam in the same. The fuel is fed at the top of the boiler, and is carried to the fireplace through the central tube A², the lower end of which ends above a cone of masonry, which spreads the fuel on the surround-

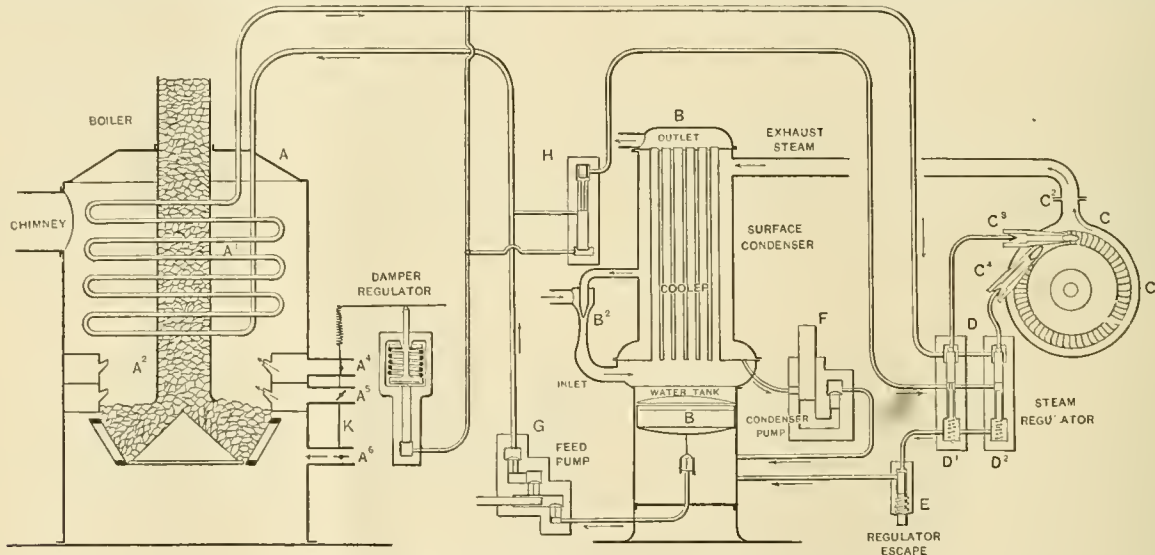

The De Laval High Pressure Steam Boiler and Turbine.

ing basket-shaped grate. The air of combustion is forced into the fireplace by means of a blower, partly through the flue A³, which enters below the grate and partly through A⁶, from which the air is forced through mouth pieces immediately above the top level of the fuel. This air, therefore, answers the purpose of consuming the smoke as well. Should the steam pressure rise too high, the air supply through A⁶ and A⁵ is cut off, and air is instead forced in through A⁴, whereby the combustibles are cooled off and the steam pressure lowered. This regulation of the combustion and steam pressure is accomplished by means of the dampers in these three pipes, which are manipulated by a system of lever, chains and rollers in the damper regulator, which consists of a piston the steam pressure on which is counterbalanced by a spring. As soon as the steam pressure changes, the piston moves in one direction or another, and thus opens or closes said dampers. The water is fed to the boiler by the feed pump G, which has several plungers (four in the 50 horse power system, and six in the 100 horse power system), in order to furnish as even a supply of water to the boiler as possible. The suction pipe of the pump is connected with the water cistern, where the supply is regulated through the float, and which, thus, by the water level, determines the amount of feed water to the boiler.

The steam generated in the spiral pipe at the exhibition plant had a temperature of 660 degrees F., and a pressure of 1,735 pounds, which at the steam turbine was reduced to 1,420 pounds per square inch. The steam is first conducted to the regulators D, which successively adjust the amount to the nozzles C³ and C⁴ of the turbine C. This regulation is accom-

plished by hydraulic pressure in the following manner: The pressure water is obtained from the discharge pipe of the feed pump to the boiler and passes a reducer, H, which reduces the pressure to that of the steam. From here it goes to the middle part of the steam regulators and drops around the piston down to the lower ends D¹ and D², where the pressure of the water and the spiral springs is counterbalancing the steam pressure in the upper ends of the regulators. The pressure of the water in the lower ends of the steam regulators is determined by the regulator escape E, which is opened and closed by a centrifugal regulator.

From the upper ends of the steam regulators the steam is conducted through four mouth pieces, or tuyeres, C³ and C⁴, with very small apertures. The turbine disk C¹ is constructed as a double turbine with two rows of buckets and a division wall. From the tuyeres the steam passes first through one of the rows of buckets, then through the division wall, and finally through the other series of buckets. The disk rotates 13,000 revolutions per minute in a 100 horse power turbine, and 16,400 revolutions in a 50 horse power one. These speeds are reduced by gearing to 1,050 and 1,500 revolutions, respectively, at the indicator shaft.

The exhaust steam from the turbines passes through the exhaust pipe C² to the surface condenser B, which is composed of vertical pipes and works with a vacuum. The condensed steam is forced into the hot water tank by the condenser pump F. The condensers are freed from air by means of an ejector, B², placed in the cooling pipe going to the condenser. The feed pump, as well as the condenser pump, are worked direct or indirect by the turbines, as are also the pump for the cooling water and the fan (not shown on the diagram). These latter

are coupled direct to the shaft of the inductor, and thus run at the same speed, 1,050 and 1,500 revolutions, respectively, per minute, while the feed pump makes 300 and the condenser pump 130 strokes per minute.

Particularly noticeable at the power plant in question was the small floor space occupied by this combination of boiler, steam turbine and dynamo, which for the 100 horse power system was only 19.7 by 11.5 feet, and for a 50 horse power system 16.4 by 8.2 feet. The 100 horse power boiler, which generated 1,765 pounds of steam per hour, was 4.6 feet in diameter and 9.8 feet high, while the 50 horse power boiler had a diameter of 3.6 feet and a height of 8.5 feet, and generated about 880 pounds of steam per hour.

Regarding the danger of explosion of the boiler under such enormously high pressure as used for obtaining this improved effect of the steam in the turbines, this is here reduced to a minimum by the exceedingly small diameter of the spiral pipe and consequent small volume of steam it contains, besides the absence of any large volume of water. The water as it enters the spiral is immediately converted into steam, and if the pipe should burst somewhere the steam in that part of the pipe would instantly escape, and so also, successively, the steam from the other parts of the boiler, until the whole contents has passed out through the chimney. Besides, these pipes are made of the very best material, drawn and hammered out from whole ingots and afterwards cold pressed and tested under a pressure several times that expected to be carried.

Experimentally, the pipes have been made to explode "directly in view of the operator" without causing any damage whatever.

WESTINGHOUSE ENGINES AND GENERATORS.

At the invitation of the Westinghouse Machine Company and the Westinghouse Electric and Manufacturing Company about 300 engineers enjoyed an instructive visit to the works of these celebrated builders at Pittsburg, Pa. The works are always interesting, but specially so now on account of the machinery that is nearly completed for shipment abroad, the large gas engine and the new Parsons steam turbine, all of which were exhibited to the visitors.

The machinery for the Metropolitan Electric Supply Company of London includes three 2,500 horse power engines, the largest built by this firm, and direct connected generators, each having a nominal output of 2,000 horse power with 500 volt two-phase current. This is a noteworthy order, and the appearance of the work justifies the expectation that more American machinery will follow this to the other side of the water. The engines and generators are mounted on separate bed plates and the exciters are connected direct to the engine shafts.

The engines are the largest of their type ever built. They

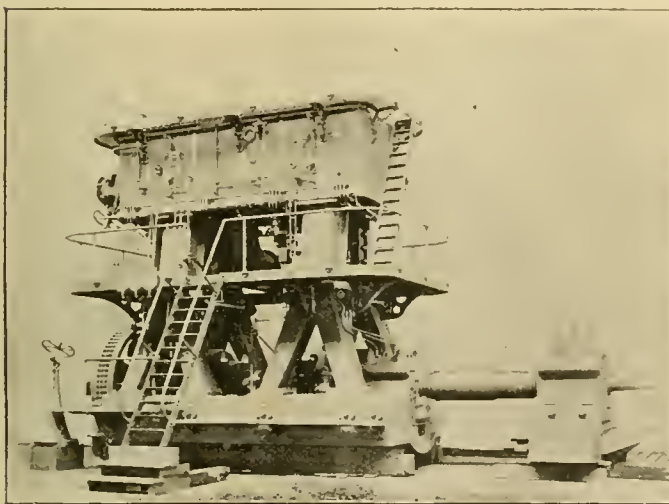

Westinghouse Engines for the Metropolitan Electric Supply Company, London, England.

are compounds, with cylinders 36 and 55 by 36 inches and are of the inclosed vertical marine type. The steam pressure may be as high as 200 pounds, though they are designed to give the best results at a pressure of 140 pounds and a speed of 120 revolutions per minute. When exhausting into the atmosphere at 133 revolutions per minute and under 100 pounds pressure the engines develop 2,500 horse power, while at 120 revolutions and 140 pounds pressure they will develop 3,500 horse power at a maximum. The bed plates are of the box form for mounting upon concrete foundations. The crank shaft is extended at one end to an outboard bearing to provide for the generator. The crank shaft is of forged steel, 14 inches in diameter, and it is enlarged at the armature to 20 inches. The piston rods are 8 inches in diameter. The weight of the outboard bearing is about 20,000 pounds, while the combined weight of one generating set is about 435 tons, the engine weighing about 210 tons. The engine is about 20 feet high. The lubrication is carefully attended to and so is the adjustment of the main bearings to take up wear. These bearings are in four adjustable sections, the lower one being cased for cooling water. The main bearings are 28 inches long, and throughout the design it is made evident that the engines are to be run for long periods without stopping. Piston valves are used, that for the high-pressure cylinder being double ported and the pair for the low-pressure cylinder being single ported.

The generators were not mounted at the time of the visit, but before we go to press one complete unit will be shipped to London, to be followed within a few weeks by the rest of the order. The fields have 62 pole pieces of laminated steel plates, the frame being in two parts split vertically, so as to be separated along the axis of the generator for easy access to the armature. The field coil winding is on copper strips placed on edge. For ease in shipment and in handling, the armature spider was cast in halves. The armature winding is in rectangular copper bars in the slots of the punched armature rings, and the ventilation of the armature is excellent. The direct current exciters are mounted on the ends of the armature shafts outside of the outboard bearings.

Among the large orders for electrical machinery were 15 complete units, including a 5,000 horse power alternating generator for each, to be erected in the plant of the St. Lawrence Power Company, at Messena, N. Y.

At the works of the machine company a 200 horse power Parsons steam turbine was running at a speed of 4,800 revolutions, direct connected to a 200 horse power generator giving a current of 900 volts and 75 amperes. The current was used for running shop motors, and also for lighting. This is the first steam turbine of this type built in this country, and its smoothness of running was impressive. We recorded the success of this motor on the "Turbinia" on page 46 of our issue of February, and on page 187 of our issue of June, 1897.

The Westinghouse gas engine was described and illustrated in our issue of September, 1897, page 302, and at that time it was stated that a 750 horse power gas engine was under construction at these works. This was an error, the horse power being 650, and the engine referred to was seen running in connection with a prony brake. This is the largest gas engine unit ever constructed, and there seems to be every reason to believe that it is a complete success. It has three cylinders, each 25 inches in diameter with a 30-inch stroke, and runs at 145 revolutions per minute. For the principles upon which it is constructed and governed, we refer the reader to our previous description, and repeat that these engines are governed by the amount of explosive mixture of gas and air drawn into the cylinder at each stroke, instead of by the common "hit and miss" principle. The governing is said to be entirely satisfactory when this large engine was coupled direct to a generator, for which purpose it was built. We are told that the gas used is mixed with about 12 parts of air and that the consumption, under very favorable conditions, has been 11 cubic feet of natural gas per brake horse power.

The steadiness of operation of the smaller gas engines was demonstrated by the lights from a 65 horse power direct connected engine, which showed no fluctuations, and this indicates perfectly satisfactory governing. It will be remembered that each of these engines is equipped with a small air compressor to be used to compress air into a receiver for starting the engine.

The visit was thoroughly enjoyed, and the visitors were impressed by the character and splendid quality of the work seen.

The disadvantages of compartment cars with no means of intercommunication are shown in a ludicrous light in the following, which is quoted from "Transport:" "The Western Railway of France has adopted a most unique method for assisting passengers who leave their carriage in order to snatch a mouthful of refreshment on a long journey, to find their seats again. It is indeed quite an educational idea. On their express morning train from Paris to St. Malo and Parame they have put carriages on with pictures painted inside. One has an elephant, another a lion, another a snake, yet a fourth a lyre, while others have anchors, huntsmen's horns, tri-colored flags, balloons, grapes, swallows, pair of scales, a star, a fishing-rod, painted on the doors. These signs, the directors believe, will be more easily remembered than mere numbers."

PERSONALS.

Mr. H. A. Bowen has resigned the position of Master Car Builder of Swift's Refrigerator Transportation Company.

Mr. John Hawthorne has been appointed Master Mechanic of the Lehigh Valley at Sayre, Pa., to succeed Mr. J. N. Weaver.

Mr. F. O. Emerson has been appointed Master Mechanic of the Louisiana & Northwest, with headquarters at Gibsland, La.

Mr. William Rees has been appointed General Master Mechanic of the Interoceanic Railway; headquarters at Puebla, Mexico.

Mr. S. C. Boutelle, Master Mechanic of the San Diego, Pacific Beach & La Jolla Railway at San Diego, Cal., has resigned on account of ill health.

Mr. H. Tandy, Superintendent of the Brooks Locomotive Works, has resigned to accept the Superintendency of the Canadian Locomotive Works at Kingston, Ont.

Mr. Frank Johnson has been appointed Master Mechanic of the Mahoning Division of the Erie Railroad, with headquarters at Youngstown, O., in place of Mr. Willard Kells, promoted.

Mr. Paul Synnestvedt, formerly with the Crane Company in Chicago, has opened an office in the Monadnock Building in that city, and will give his entire attention to patent law business.

Mr. Arthur S. Bosworth has resigned as Purchasing Agent of the Maine Central, and is succeeded by Mr. Charles D. Barrows, formerly Assistant Purchasing Agent. Headquarters, Portland, Me.

Mr. Ferdinand W. Peck of Chicago has been appointed by President McKinley to succeed the late Moses P. Handy as Commissioner General of the United States for the Paris Exposition of 1900.

Mr. Thomas T. Johnston, of Evanston, who has been known for his good work at Assistant Chief Engineer of the Sanitary District of Chicago, has been promoted to the position of Consulting Engineer.

Mr. J. E. Gould, formerly Assistant Master Mechanic of the Pennsylvania lines at Dennison, O., has been appointed Master Mechanic of the Toledo & Ohio Central shops at Columbus, O., to take effect Sept. 1.

Mr. E. W. Knapp was on July 12 appointed Master Mechanic of the Michoacan & Pacific, in charge of the motive power department, with headquarters at Zitacnaro, Mex., vice Mr. W. H. Rice, resigned.

Mr. A. M. Parent has been appointed Manager of the Works of Pullman's Palace Car Company at Pullman, Ill., and the authority of Mr. Frederick Wild, Assistant Manager, has been extended over all departments.

Mr. G. Wirt has been appointed Master Mechanic of the Big Four-Chesapeake and Ohio and Louisville and Jeffersonville Bridge Company, vice W. A. Bell resigned. Mr. Wirt was formerly General Foreman of the Big Four at Wabash.

Mr. Willard Kells, heretofore Master Mechanic of the Mahoning Division of the Erie Railroad, has been appointed Master Mechanic of the Chicago & Erie, with headquarters at Huntington, Ind., in place of Mr. J. Hawthorne, resigned.

Mr. Cornelius Shields has been elected to the Vice-Presidency of the Spokane Falls & Northern, in charge of the operation of the road, with headquarters at Seattle, Wash. Mr. Shields has also been chosen President of the Columbia & Red Mountain, which is a part of the Spokane Falls & Northern system.

Mr. A. L. Studer, heretofore Master Mechanic of the Southwestern Division of the Chicago, Rock Island & Pacific at Trenton, Mo., has been appointed Master Mechanic of the Illinois Division, with headquarters at Chicago, in place of Mr.

John Gill, who is now Master Mechanic of the Southwestern Division at Trenton.

Mr. W. W. Peabody, who has been Vice-President and General Manager of the Baltimore & Ohio Southwestern, has been relieved of the responsibility of the operation, which has been given to Mr. I. G. Rawn as General Manager. Mr. Rawn has been General Superintendent of the road for a number of years. Mr. Peabody has been Vice-President since January, 1890, and General Manager since November, 1893. Mr. Rawn was appointed General Superintendent of the Baltimore & Ohio Southwestern in January, 1890. He was formerly Master of Transportation of the Kentucky Central and was for one year with the Chesapeake & Ohio as Division Superintendent and Superintendent of Transportation.

Mr. William Forsyth has been appointed Superintendent of Motive Power of the Northern Pacific Railway to succeed Mr. E. M. Herr. Mr. Forsyth began railroad work on the Philadelphia & Reading and was afterward connected with the Pennsylvania, and he is best known as Mechanical Engineer of the Chicago, Burlington & Quincy Railroad, the position he now resigns and has held for a number of years. He has been closely identified with the development of the motive power and rolling stock of the road. Being a keen student as well as an accomplished engineer, he is one of the foremost among those who have combined engineering and practical railroading in the administration of motive power matters. His experience, which has been wide and thorough, has admirably qualified him to fill his new position. The Northern Pacific is an excellent field for his work and we congratulate Mr. Forsyth and the road upon the appointment.

Mr. Edwin M. Herr has resigned as Superintendent of Motive Power of the Northern Pacific to become Assistant General Manager of the Westinghouse Air Brake Company. Mr. Herr has had an unusually wide experience. He started as a messenger boy for the Western Union Telegraph Company, and entered railroad work on the Kansas Pacific Railroad in 1878, since which time he has been busy with promotions, but still has had time to secure a good technical education. He has devoted most of his attention to the mechanical department, and is specially well equipped for that work by intimate knowledge of operating matters obtained when he was Superintendent of Telegraph and Division Superintendent on the Burlington. The higher positions which he has held in mechanical departments are Master Mechanic of the Chicago, Milwaukee & St. Paul, Superintendent of the Grant Locomotive Works and Assistant Superintendent of Motive Power of the Chicago & Northwestern. By this change the railroad service loses one of its best men, and the Westinghouse Air Brake Company acquires one whose qualifications are altogether exceptional.

THE PRESENT FORM VERTICAL PLANE COUPLER—
DOES IT MEET ALL REQUIREMENTS?—
HAS IT COME TO STAY?

By Pulaski Leeds.

In a paper by Mr. Pulaski Leeds, Superintendent of Machinery, Louisville & Nashville R. R., read before the Central Association of Railroad Officers, the faults of the present types of M. C. B. coupler are outlined in a forcible way. We cannot answer the question: "What are we going to do about it?" but commend the suggestion from Mr. A. M. Wait printed on page 256 of our August issue in this connection. Mr. Leeds said:

A concise statement of my opinion would be an emphatic negative to the first question; and an equally emphatic affirmative to the last, and "What are you going to do about it?" It seems to me scarcely credible (or creditable) that the adoption of this device should have resulted from a careful investigation and consideration of the conditions and requirements of service; first, that the concussion should be evenly and squarely met on a central line; second, that the pulling strain should be on a central line to avoid all tendency to crowd the flanges against the rail; third, that the connection should be so flexible that there should be no unnecessary friction at any time, or difficulty in coupling on any practicable curve; fourth, that the device should be capable of having its strength increased to meet future requirements of heavier motive power; fifth, that it

should be always operative; sixth, that there should be as great a uniformity as there was in the link and pin.

In my opinion the present style of vertical-plane coupler contains none of these essentials. When cars are thrown together the greater part of the blows are received at the point of greatest adverse leverage, far outside the center line of the column. In pulling, the line of strain is considerably out of center. The connection is not as flexible as it should be, as for obvious reasons the bar must not have any great amount of lateral movement; hence, where there is an appreciable difference in the overhang of two cars, as in the case of a car with a six-wheeled truck coupled to one with a four-wheel, there is a great leverage tending to crowd the car with the shorter overhang off the track. Not only has this been demonstrated by the derailing of tenders where this rigid connection has been made, but it can be easily demonstrated by diagraming a four-wheeled baggage express car, built without platforms, and a six-wheel car with such platforms. The centers of the couplers will be several inches out of line with each other, and it has been demonstrated that in order to force them into line a transverse pressure of upward of 50,000 pounds has to be exerted. While these are exceptional cases, the same holds good in degree throughout our whole equipment, and taken in connection with the "demolition grind," both vertical and horizontal, caused by the motion of the cars and a rigid sliding bearing, as against the pivoted action of the link and pin, not only causes our trains to pull harder, but is destructive to both equipment and track.

This device was adopted when the car equipment and motive power were a great deal lighter than now, and the lines that

answer the query, "What are we going to do about it?" The great number already applied, and the fact that within a short period all cars must couple automatically by impact, make it the standard of the country; and further, the fact that all couplers of the future must couple with this type prevents not only the introduction of any other type, but any improvements in this type as to the essential of strength. As I have heretofore remarked, these outlines were designed to meet the requirements of a service when the heaviest motive power was such as is now being retired from service as being too light for economical operation, and while the ultimate tensile strength of the bar may still meet the requirements of the increased motive power, still the most destructive agency has been increased in the same proportion, i. e., the blows received in yards from moving cars of from 90,000 pounds gross weight, as against those of about 50,000, the velocity being a variable and unknown quantity, but probably not decreased, yet with all its faults we have still, and, with the immense sums expended upon it, we are likely to have it for many years to come; therefore the only thing we can do is to try and make it the most effective, serviceable, economical and least dangerous possible.

THE HEDLEY MOTOR CAR TRUCK.

To provide for the heavier motors required under the cars of the Lake Street Elevated Railway, Chicago, Mr. Frank Hedley, General Superintendent of the road, designed the truck,

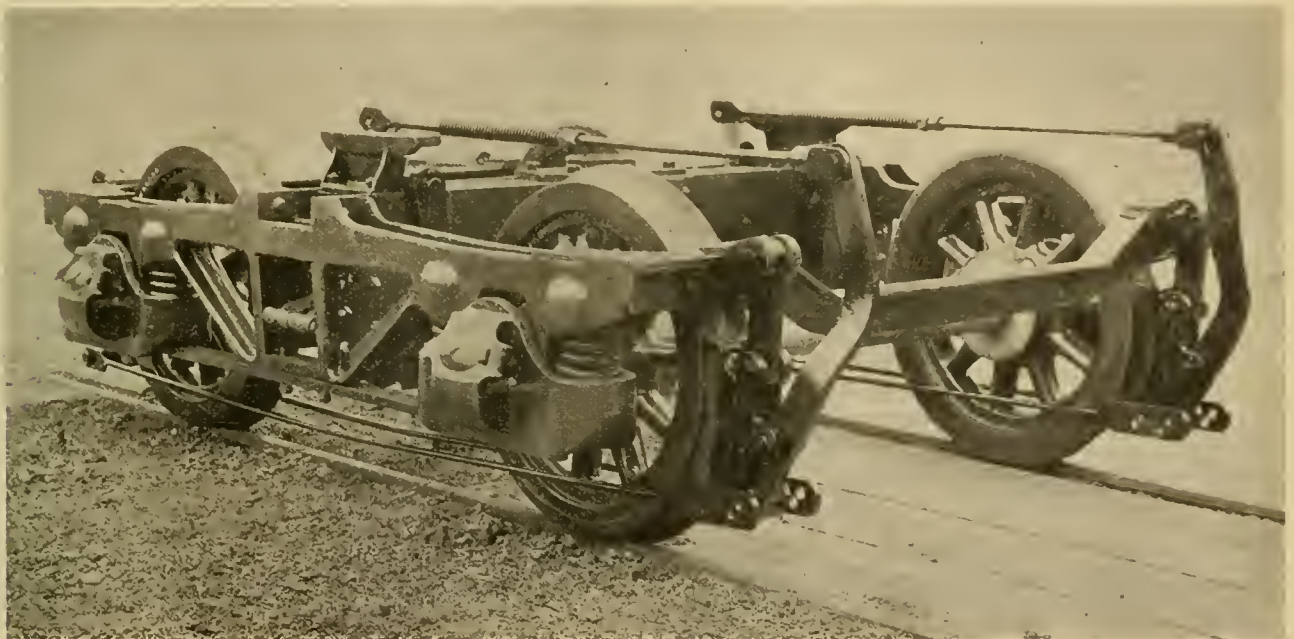

Hedley's Motor Car Truck—Lake Street "L" Railway, Chicago.

were adopted were those that had been produced to meet the requirements of that time and in competition commercially with the link and pin, and as those lines were such as precluded the possibility of increasing the proportions, the only increase in strength lies entirely in the quality of the material used, and the temptation to consider first cost is so strong as to, in a great measure, defeat this measure; in fact, this point of first cost is so strong that there are couplers in which the weight has been reduced from the original construction, enabling the manufacturer to reduce the price per car while getting practically the same price per pound.

As to the unlocking devices being at all times operative, it can be safely said that any coupler which can be fairly criticised upon fixed mechanical principles as likely to give trouble at a given point will, after a certain amount of strain and wear in service, surely prove troublesome at the point thus criticised. This criticism can fairly be made upon most all couplers in service to-day; thus any coupler of a design likely to break or get out of order readily, to couple with great difficulty under some of the ordinary conditions of service, to come uncoupled, or not to uncouple when required, is faulty, and such defects are more likely to develop when all cars are equipped with the M. C. B. couplers.

While it is incumbent upon us to so construct our draft rigging as to render the danger of bars pulling out as small as possible, still it is a fact that they do so, and also that bars break, in which case we lose the old safeguard of the link and pin holding the head or bar up until the train is stopped; hence there has been an element of great danger introduced, and which no effective device, so far as I know, has been provided to meet.

But allowing that there are some who agree with me, please

which is shown in the accompanying engraving. The trucks were built by the Siemens & Halske Electric Co., and they are reported to be entirely satisfactory.

The side frames are of cast steel, including the pedestal jaws, and the outline is in general that of the diamond-frame truck, with pedestal tie bars attached to the side frames by bolts. The transoms, which are in the form of deep steel plates, are also attached by bolts. The truck bolster is carried by links 21 inches long for the purpose of giving an easy side motion, and together with the arrangement of the springs, this feature results in very easy motion. One of the objects of the design being to give room for two G. E. 55 motors of 175 horse-power each, it was necessary to avoid the use of brake beams, and the illustration shows very clearly how this was accomplished by the aid of brake rods inside and outside of the wheels. The cross-tie bars at the end of the truck frames, which are of T section, are offset downward to clear the draft gear. The weight on each journal is about 7,000 pounds and the amount of clearance under the motor casings from the ties is 3 inches. The wheels are 33 inches in diameter and the wheel base is 6 feet.

A promising experiment with a Leach sander is now being tried on one of the trucks, whereby sand may be delivered under all four wheels. Hose connections are used between the motorman's cab and the sanders. We are informed that by using sand a train may be accelerated to a speed of 24 miles an hour in 16 seconds, which is exactly one-half the time required for the same speed without sand.

(Established 1832)

AMERICAN ENGINEER

CAR BUILDER AND RAILROAD JOURNAL.

29TH YEAR.

67TH YEAR.

PUBLISHED MONTHLY

BY

R. M. VAN ARSDALE,

MORSE BUILDING.....NEW YORK

G. M. BASFORD, Editor.

SEPTEMBER, 1898.

Subscription.—\$2.00 a year for the United States and Canada; \$2.50 a year to Foreign Countries embraced in the Universal Postal Union. Subscriptions for this paper will be received and copies kept for sale by the Post Office News Co., 217 Dearborn Street, Chicago, Ill.

EDITORIAL ANNOUNCEMENTS.

Advertisements.—Nothing will be inserted in this journal for pay, EXCEPT IN THE ADVERTISING PAGES. The reading pages will contain only such matter as we consider of interest to our readers.

Special Notice.—As the AMERICAN ENGINEER, CAR BUILDER AND RAILROAD JOURNAL is printed and ready for mailing on the last day of the month, correspondence, advertisements, etc., intended for insertion must be received not later than the 20th day of each month.

Contributions.—Articles relating to railway rolling stock construction and management and kindred topics, by those who are practically acquainted with these subjects, are specially desired. Also early notices of official changes, and additions of new equipment for the road or the shop, by purchase or construction.

To Subscribers.—The AMERICAN ENGINEER, CAR BUILDER AND RAILROAD JOURNAL is mailed regularly to every subscriber each month. Any subscriber who fails to receive his paper ought at once to notify the postmaster at the office of delivery, and in case the paper is not then obtained this office should be notified, so that the missing paper may be supplied. When a subscriber changes his address he ought to notify this office at once, so that the paper may be sent to the proper destination.

The paper may be obtained and subscriptions for it sent to the following agencies: Chicago, Post Office News Co., 217 Dearborn Street. London, Eng., Sampson Low, Marston & Co., Limited St. Dunstan's House, Fetter Lane, E. C.

The "Battle of the Gages" seems to be "on" again in discussions of the Institution of Mechanical Engineers of England. There seems to be an extraordinary vitality to the idea that narrow gage roads are much cheaper than standard to build, and we direct the attention of those who believe this to the article on the "Relative Cost of Narrow and Standard Gage Railroads," by Mr. M. N. Forney, on page 369 of our issue of November, 1897.

There is nothing more difficult about the administration of a shop plant than piecework. Those who have settled upon a satisfactory plan find that very soon new conditions arise which make it necessary to change the prices, no matter how well adjusted they may have been originally. The greatest trouble, however, is found at the outset in fixing the rates for the first piecework schedule, and this is the key to the whole subject. We are told that the method adopted in the Rugby Works of Messrs. Willans & Robinson was to establish prices slightly higher than those for day work, and to divide the difference between the piece work and the day work wages evenly between the works and the men. By this system the men have every inducement to earn all they can, and the benefit to the works is direct, and is clearly understood by the men.

In describing the works of the Midland Railway of England on the occasion of the recent visit of the Institution of Mechanical Engineers, "The Engineer" (London) said: "We were somewhat disappointed to see so few really modern machine tools in the workshops, and felt that surely considerable saving in cost of production could be effected by the addition of machines of more recent type." This should be food for thought for a great many high railroad officers in this country also.

The effect of segregation on the wearing qualities of bearing metals is so little understood that we are glad to give our readers the benefit of the experience of Mr. Guillian H. Clamer, in his paper before the Franklin Institute on the "Microstructure of Bearing Metals," a reprint of which is to be found elsewhere in this issue. The value of bearing metals depends not alone upon the metals that are used to form the alloy, but also upon the structure of the product, and it is not at all unlikely that the microscope will be called upon generally to assist in future tests of bearing metals. Mr. Clamer believes the micro test to be even more important than chemical analysis, and by following the account of his work there appears to be good ground for such an opinion. Good judgment and wide experience are required in using the microscope in this connection, but the importance of cool bearings in train service calls for more care in the selection of bearing metals than is generally given. This is a good subject for the most careful scientific examination.

SIDE BEARINGS FOR CARS.

Shall the load of freight cars be carried upon the center plates alone or upon the center plates and the side bearings? This live question grows out of the increasing capacity and weight of cars. The original object of the side bearing was not to support the load under ordinary running conditions, but to prevent excessive tipping or rocking of the car in passing curves; in the future, however, it may be called upon to do much more than this.

We should say that the load should not be allowed to rest permanently upon the side bearings unless a satisfactory roller or "anti-friction" bearing is used, and many look askance at the roller bearings when applied under such peculiarly trying conditions, but if they can be made satisfactory they present an ideal arrangement, as Mr. Waitt has pointed out. The great waste of locomotive power which is caused by the trucks being held askew by ordinary side bearings that are in contact has already been commented upon in our pages and a reasonable conclusion seems to be that the car structure, when ordinary side bearings are used, should be made so strong that the side bearings will never come into contact except when they are needed to prevent the tipping or oscillation of the car.

If body and truck bolsters are made stiff enough to prevent the deflection and permanent set necessary to bring the bearings into contact there will be no trouble, but this can be carried to an extreme which would not be permissible on account of the weight of the bolsters. It may be said here that the advantage of lightness would be with the roller side bearings and this is an incentive for the production of a good bearing of this type, for it would permit of using very light bolsters. The distribution of the load along three points in the length of the bolsters instead of concentrating it at the center has much to recommend it, and the problem is not to be finally settled without due consideration of the question of weight. It has been said that a car cannot be carried on six points, but it must be admitted that if side bearings may be used as supports the objection to a bolster with considerable flexibility are largely removed, and flexibility would assist in equal distribution of the load. It has been suggested by Mr. F. M. Whyte of the Chicago & Northwestern that bolsters may be lightened or, if not lightened, they may be made stiffer in service by a better arrangement of the car body truss rods, which will

bring the loading from the rods nearer the center of the bolsters. This seems to be an excellent idea and it will probably help materially in the right direction, which is to transmit the load so that it may be most favorably resisted.

Metal bolsters which will carry their loads by the center plates are now made by several firms, and the best solution of the problem at this time is to use them. It is very important to remember that a body and a truck bolster together form an important combination, of which each must do its part. It will pay to discard wooden bolsters as rapidly as possible and replace them by strong, stiff steel ones. Then let the man who has a good "anti-friction" side bearing bring it forward. It is also worth while to consider whether an "anti-friction" center plate bearing is not equally important.

THE METRIC SYSTEM.

This system has been before the world for a long time, and its adoption by nearly all civilized countries, together with the present tendency toward the extension of American trade, renders its consideration specially important at this time.

The United States and England have not yet adopted it, and the question is taking such shape as to affect the foreign trade of both countries. There are faults in the metric system, and this fact, coupled with the difficulties of changing methods of weighing and measuring, lead some influential persons to urge the perpetuation of the present systems, with an idea that the United States and England are important enough commercially to warrant the continuance. We do not believe this to be the right view to take. If we want foreign trade we must use the measures required by that trade, and it must be conceded that the use of the metric system must increase in spite of opposition. We shall go even further than this and say that in time the metric system will force its way through all our institutions in spite of efforts to stop it. Then shall we have two systems or one?

The time has passed, we think, for taking sides, and it will soon become necessary to either help or hinder progress. It is better to take a far-sighted view and fulfil our national promise for progressiveness. The period of change will be uncomfortable and inconvenient, but short, and we commend the expressions of Mr. Grafstrom and Professor Mendenhall, elsewhere in this issue, on this phase of the subject, for attention. All that is necessary is that the people shall see it to their advantage to use the metric system and the change will be made, and not until then. The situation warrants educational methods and they will undoubtedly be used with ultimate success.

Sentiment favoring the change in England is rapidly growing, and as an example of the expression of opinion there we quote the following from "The Mechanical Engineer," of Manchester:

"The British Consul in Amsterdam has reported that some time ago the iron and steel manufacturers throughout the German Empire adopted a standard classification based on the metric system. For instance, angle irons and bars, of which the production in Germany is very large, are rolled by all manufacturers to identical dimensions. This systematic procedure has led other foreign countries to adopt the German classification, more and more to the disadvantage of British manufacturers. The consul reports that in Holland there is an undoubted preference for German sizes, based on the metric system, and that it is chiefly owing to this that Germany has obtained many orders for railway bridges and other material. He adds that, 'as regards pipes for waterworks, it is absolutely certain that the Dutch market is completely lost to Great Britain as far as new works are concerned, from the same cause.' He says that recently a Belgian firm obtained a large contract for water-piping in Holland, and was obliged to guarantee that the German normal classification should be adhered to. He concludes that in the growing competition of rival manufacturing countries the lead cannot be held by

any country which has not adopted the metric weights and measures. This opinion is fully confirmed by consular reports from other places, and the wonder is that we don't adopt the obvious remedy. But without a strong lead from the Government, we shall doubtless continue to drift along until it is too late to get back what we have lost."

TESTS OF LOCOMOTIVE LAGGING.

Comparative tests of materials for locomotive boiler insulation, when made under conditions differing widely from those under which it is used, are open to criticism, and even to doubt, as to the adaptability of the data obtained for comparison under service conditions. Tests have been made in still air, and with comparatively small surfaces covered with the insulation, and until now all such comparisons have been made in this way. It is well known that air currents affect the radiation, and that the best of insulation will not overcome the bad effect of lagging construction whereby air can get under the jacket, and it is clearly advantageous to have road tests in order to take this influence into account. Until very lately such tests have not been considered as a possibility because of the difficulty of securing data, but a plan recently devised by Prof. Goss and the mechanical officers of the Chicago & Northwestern Railway promises to throw new light on this side of the subject.

We are informed that tests have already been undertaken on that road of a number of boiler coverings, the plan being to couple two engines together, the first of which has no fire and no water in the boiler, but is supplied with steam at a pressure of 160 pounds from the engine in the rear. The second engine pushes the first over the road, and the amount of water condensed by the same boiler with the different laggings while going over the road is weighed in the tender tank. It is true that the conditions of wind velocity and direction may not be uniform, but by careful work the results may be expected to be more reliable than any that have been obtained. The plan is both ingenious and novel, and if the weather conditions are favorable an interesting comparison may be expected. Without doubt wooden lagging will give a very poor showing, and the coverings which insure the best joints for the exclusion of air currents and at the same time are good insulators will be at the head of the list.

NOTES.

A test for determining the hardness of cast iron was described recently in a paper by Mr. C. A. Bauer before the American Foundrymen's Association. A drill press is rigged with a wheel and weight in such manner as to insure uniform pressure. The revolutions of the drill and the depth drilled are noted, and comparisons are thus made by which the relative hardness of different samples of iron are determined.

A moveable sidewalk with two speeds is to be installed at the Paris Exposition. Instead of the plans followed in Chicago and Berlin there will be a smaller number of driving wheels. These will be in the stationary track, spaced 127 feet apart, and will be electrically driven, giving motion to a central rail on the under face of the platform. The bearing wheels will be 20 feet apart, and will be placed under this rail, and will also carry the platform. The central rail supports half the weight of the platform, while smaller wheels at the sides carry the rest of the weight to side tracks. This plan gives great flexibility to the platform, which is in short sections and permits of using very short curves. The high speed platform will run at the rate of six and a quarter miles per hour, and the slow speed platform runs at one-half that rate. The tracks will be about two and a half miles long, with stations nearly 700 feet apart. The power required will be about 475 horse-power and the capacity nearly 39,000 passengers per hour.

The cost of large caliber ammunition in the present war is very great. A 13-inch gun firing a projectile weighing 1,000 pounds consumes 550 pounds of brown prismatic powder, costing from 30 to 33 cents per pound. "Engineering News" recently printed the following interesting figures: At the lower price the powder for a single charge costs \$165. The common 13-inch shell is said to cost \$116.63, but the armor-piercing projectile costs \$418. To these items must be added cartridge bags, primers, freight, etc., amounting to about \$15, or \$296.63 for the shell discharge, and \$588 for the discharge of an armor-piercing projectile. As a 13-inch gun can be discharged about twenty-five times an hour, the work of one for an hour may cost the Government about \$15,000. The 8-inch gun costs about \$65 for each shot; the 5-inch rapid-fire costs \$33; the 6-inch breech-loading shot costs about \$40, \$14 being for the powder; and each round of the Hotchkiss 6-pounder gun is estimated to cost \$5.70, and a 1-pounder \$1.12. White-head torpedoes cost \$2,500 each, and a Howell torpedo \$2,220.

Oil fuel was tried at sea for the first time in the British navy at Portsmouth, on Friday, July 29. Some months ago the Admiralty sanctioned an experiment with the system invented by Mr. Holden of the Great Eastern Railway, on board the torpedo boat destroyer "Surly," and in the interval various trials have been carried out in one of the dockyard basins. At these the chief difficulty was to furnish a sufficient feed of oil, but this has been overcome by the provision of an overhead feed-tank. There are four boilers on the "Surly," two of which are still retained for coal fuel, but the others have been adapted for oil. In lighting the latter series the elements of combustion are oil and coal, but as soon as a sufficient heat has been generated bricks replace the coal and are heated from the oil spray. At the trial no difficulty was experienced in obtaining a sufficient spray, and the heat was so well maintained that at times the thermometer indicated 150 degrees F. in the stokehole. There runs over the measured mile in Stokes Bay were made, and, while a speed of 16 knots was hoped for, the runs gave a mean of 14 knots; but, as this was only a preliminary trial, the result was regarded as satisfactory. The oil used had a flash-point of 280 degrees F.

The remarkable trip of the U. S. battleship "Oregon" from San Francisco to Key West is full of interest, not the least of which is the part performed by the engineers, to whom the greatest credit is due for the fine condition of the machinery en route and after arrival. In a letter to a friend, published in the New York "Sun," Mr. C. N. Offley, First Assistant Engineer in charge of the "Oregon's" starboard engine room, tells the reasons for the successful trip in the great and constant care given the machinery, and concludes with the following tables of fuel and speed data taken on the cruise:

	Dis- tance, knots.	Time, hours.	Speed, knots per hour.	Knots run per ton of	
				Coal, tons.	coal.
Brewerton to San Francisco.....	827.7	72	11.49	221.0	3.74
San Francisco to Callao.....	4,076.5	371	10.99	962.0	4.24
Callao to Port Tamar.....	2,529.9	212	11.93	785.0	3.22
Port Tamar to Sandy Point.....	132.0	9	14.55	68.0	2.00
Sandy Point to Rio de Janeiro.....	2,247.7	223	10.08	657.0	3.42
Rio to Bahia.....	700.0	*	*	288.0
Bahia to Barbadoes.....	2,229.0	193	11.55	620.0	3.59
Barbadoes to Jupiter.....	1,683.9	142	11.86	478.5	3.3
Jupiter to Key West.....	280.0	27	10.37	77.9	3.6
Totals	14,706.7			4,155.4	

*Speeds variable. Data unreliable.

The effect of the long-distance telephone in overcoming the necessity for very fast limited train service between New York and Chicago is interesting. The "Railroad Gazette" directs attention to this development, and while unable to give definite statements as to the extent of the loss, it is believed to be considerable. The telegraph is not adapted to long conversations, and is relatively slow when compared with the telephone, but it is used to begin business conversations which

are completed over the long-distance telephone lines, whereas people had formerly to actually meet in order to transact business that required haste, and this necessitated the use of fast trains. The result is advantageous to business men and is not all loss to the railroads, because long-distance "flyers" do not pay unless the excess rates are very high, and the roads may now confine their efforts to the difficulties of operation, which are bad enough, even with normal speeds. We are informed that the North Shore Limited 24-hour trains of the New York Central and the Michigan Central railroads leaving New York at 10 o'clock a. m. and Chicago at 4 p. m., have been discontinued. How far the telephone has assisted in this result is not known, but it is credited with a good share of influence.

The question of safety devices for the elevators of the new "Empire Building," just completed in New York, has been settled by the application of air cushions to ten passenger elevators. Each shaft is walled up independently as high as the third floor, and is made a close fit for the car, and the last fifty feet of the drop of each elevator is therefore in the air cushion. The elevator cars may fall into their cushions, whereupon the air is confined in the bottom of the shaft, and, by its gradual escape, lets the elevator down easily without shock. It is stated that a car has been dropped from the twentieth floor of this building without breaking eggs and incandescent electric lamps that were placed on the floor of the car. The pressure of the air caused by a fall from the top floor, a height of 290 feet, is calculated to be about three and a half pounds. The estimated proportion between the length of the cushion and the length of the drop is as one is to six. The advantages of this safety device are: Simplicity, reliability, absence of moving parts and the sacrifice of no room that could be used for any other purpose. The only precaution necessary seems to be to make the doors of the lower floor entrances air tight, and this is easy. This is an interesting case of the survival of an old idea that is good, and in the interests of safe elevator transportation in high buildings we would like to see more of these applied.

STEAM CONSUMPTION—STATIONARY ENGINES.

A four days' test on a Sulzer steam pumping engine by Bryan Donkin is reported in a recent issue of "The Engineer" (London), showing remarkably low consumption of steam.

The indicated horse-power at full speed was from 201 to 207, and 101 at half speed. The boilers were of the Cornish type, supplying dry but not superheated steam at 150 lbs. pressure. The heat efficiency was from 81 to 82 per cent., and the consumption was from 11½ to 12 lbs. per horse power when running at full speed, and it rose to 12¾ lbs. at half speed. The cylinders are 14 3-16, 23½ and 34 7-10 in. in diameter, with a common stroke of 39¾ in. The cylinders and cylinder heads are steam jacketed. In commenting upon these figures "Power" compiled the following records of tests, showing less than 12 lbs. of steam per horse power per hour:

	Lbs.
60 H. P. Schmidt compound engine at Annen, Germany—reported by Hill—steam superheated 315° F.....	9.55
100 H. P. Schmidt compound factory engine at Osnabruck, Germany—reported by Hill—steam superheated 267° F.....	10.41
700 H. P. Sulzer triple expansion mill engine at Chemnitz, Germany—tested by Saxon Boiler Inspection Co., and reported by Hill—steam superheated 18° F.....	10.71
575 H. P. Leavitt triple expansion pumping engine at Chestnut Hill, Mass.—reported by Miller.....	11.22
2,000 H. P. Sulzer triple expansion mill engine at St. Petersburg, Russia—reported by Hill.....	11.30
575 H. P. Allis triple expansion pumping engine at Milwaukee, Wis.—reported by Carpenter.....	11.68
1,300 H. P. Sulzer triple expansion mill engine at Orchow, Russia—reported by Hill.....	11.7
550 H. P. Greene-Wheelock cross compound mill engine at Grosvenor Dale, Mass.—reported by Barrus.....	11.89
1,100 H. P. Allis triple expansion pumping engine at Chicago—reported by J. N. Warrington and R. W. Hunt Co.....	11.97

THE TRAVELING ENGINEERS' ASSOCIATION.

The sixth annual convention of the Traveling Engineers' Association will be held at Buffalo, New York, commencing Tuesday, Sept. 13, at the Genessee House. The list of subjects is as interesting as usual and a successful and profitable meeting is promised.

WOOD'S CAR SEAL.

The device known as Wood's car seal, which was formerly manufactured by the Q. & C. Co., and now controlled as well as manufactured by them, has met with such success as to warrant an illustrated description. The seal is in the form of a hasp and a hook combined. The hasp is of wrought steel, having a turret-shaped piece of malleable iron riveted to its center. The hook of the hasp is enlarged at its pivot end and surrounds the turret in the form of a strap. When the hook is raised to its uppermost position the seal, which is composed of a peculiar material as strong as glass, which will break in small pieces, is inserted into slots, where it is held behind the vertical bars. It is inserted from the right hand side, and when the hook is raised the portion of the strap surrounding the turret which is cut away at the bottom in the upper figure is brought opposite the slot to admit the seal. When the hook is then lowered in securing the door the movement of the strap locks the seal in position, and in this condition the door is safe from thieves, because the next upward movement of the hook breaks the seal, as shown in the lower figure.

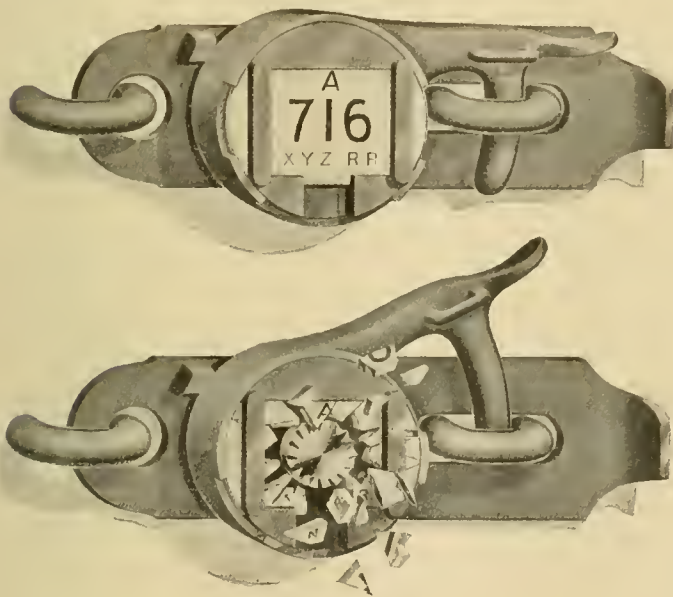

Wood's Car Seal.

ure. The rim of the hook operates a cam by means of a ratchet and spring in the inside of the turret in such a way as to throw the central plug, shown in the lower figure, out against the inner face of the seal, breaking it, whereupon it drops out of place.

The requirements for a good car seal as reported by a special committee of the Freight Claim Agents' Association in Chicago in 1893 are substantially as follows:

It must be so made as to prevent rusting from exposure to rain and snow and must not be clogged by dust. It must be self-contained, not requiring any instrument for application or removal, and its operation must be such as to prevent imperfect sealing by carelessness. The numbers or marks must be distinctly seen, because the records are often taken at night and in bad weather. The seals must be easy of application, because they are applied in cold weather, when the hands of the sealer are likely to be incased in mittens, and finally, the cost of the seal and device for its attachment must be low.

The claims made for the device are that it cannot be tampered with without breaking it; it cannot be left half sealed without leaving the door unlocked, and in general it meets the conditions outlined as to what a good seal ought to be.

We are informed that some of the largest railroad systems in the country contemplate adopting this seal as a standard.

TRAIN SIGNALING IN ENGLAND.

Communication in trains whereby passengers may either stop a train or make known the necessity for doing so is now occupying the attention of the English Board of Trade, of the railroad men and of the traveling public of that country. The reason for agitating the subject so extensively now appears to be found in a desire to put an end to the atrocities made possible by the compartment system of cars used in England. To us the best solution seems to be a revision of the construction of cars upon the intercommunication plan. This, however, entails expense, and, whether finally accomplished or not, something needs to be done at once to remedy the existing evils. A committee of the Board of Trade has made a report, of which the following gives the substance:

"That of the methods of communication at present adopted the outside cord system should be condemned as inefficient, while the systems in which the cord or wire is inside the carriages cannot be regarded as satisfactory. The principal electric systems, and the communication by means of the brake may, however, be held to be efficient; that no one of the electrical systems so far excels the others as to enable the committee to recommend it for general adoption, although they prefer the system of communication which has been experimentally used by the Great Eastern Railway Company; that the law should be extended so as to require the provision on all trains of an efficient means of communication between passengers and the servants in charge of the trains, which should also be used as a means of communication between the guards and the driver."

The conditions which the apparatus should fulfill are stated as follows:

"It should lend itself readily to the interchange of carriages between different railways; it should be easily applicable, and should communicate directly with the driver as well as with the guards, while the means by which it is actuated by the passenger should be in a conspicuous position, either in the center or at both ends of the compartment, without affording too great a temptation to passengers to tamper with it; it should be reasonably cheap in initial cost and maintenance; it should afford an indication outside the carriage, and a passenger should not be able to replace the means by which the alarm is given; it should not entail the use of additional couplings to those already existing, viz., the screw coupling, the side chains, the automatic brake, and the heating apparatus; and it should be capable of being used as a means of communication between the driver and the guards of a train as well as between the passenger and the driver and guards."

The Board of Trade has expressed a preference for an electrical apparatus, devised by Mr. F. Hollins, Telegraph Engineer of the Great Eastern Railway, which to us seems decidedly complicated and unnecessarily elaborate. Its essentials are an electric circuit throughout the train, of which the Westinghouse air brake pipes form one conductor, a dry battery, a bell and a visual indicator on the engine, a bell and push button in the brake van, a lever switch in each compartment to operate the bells, and arranged to be locked when once operated and released only by the guard, an indicator on the outside of the car at each compartment to show in which compartment the lever switch has been operated, and a specially designed Westinghouse coupling which contains the electrical contact mechanism for attaching the wire circuits between the cars.

This is an exceedingly round-about arrangement which will undoubtedly meet the peculiar and exacting requirements of the Board of Trade, but why it should be made necessary to employ so complicated a system is beyond our comprehension. The Westinghouse air signal seems to be all that is desired in this country and it may be adapted to perform all the necessary functions of similar requirements abroad. The outside cord system has been so inefficient as to lead to the establishment of radical regulations, whereas a device of this kind should have a gradual growth or development, simplicity being always borne in mind.

The moral to be drawn from the experience of the railroads of England in this case is that they should take the initiative in providing safety appliances and not wait for outside pressure, due to aroused public opinion, to compel them to put on apparatus which is more elaborate than necessary or desirable. The air signal so generally used on our roads would probably now be thought to answer every purpose in England if it had been employed voluntarily when the need for better appliances was first felt. We have no Board of Trade at present, but unless our railroads bear in mind this principle of taking the initiative in regard to safety appliances and act upon it to a greater extent than in the past, similar restraints may be expected to be applied by the public in this country as in England.

A SMOOTH-RUNNING AIR COMPRESSOR.

A very extensive application of compressed air has been made by the Ingersoll-Sergeant Drill Co. at the works of the Tide Water Oil Co., at Bayonne, N. J., in which a saving of 178 boiler horse-power, which is equivalent to \$4,450 per year, has been effected by the substitution of compressed air for steam in a number of the processes in refining. This is of interest chiefly to our readers in connection with the Class D air compressor, shown in the photograph, which was taken while the machine was running at a speed of 150 revolutions per minute. The machine is of the duplex belt driven type, and the

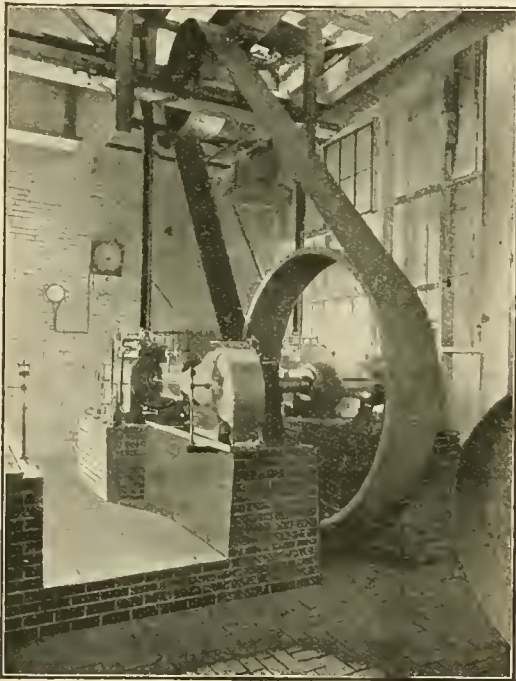

Ingersoll-Sergeant Duplex Belt-Driven Air Compressor.

appearance of the belt and of the engine and fly wheel indicate very smooth running. This machine has a stroke of 14 inches and is of the same type as those used by the Pullman Palace Car Co., at the Pullman Works, by the Lowell Machine Shop, Lowell, Mass., and others. The machine is well built, and is giving very satisfactory service. There are many cases where belt compressors are more desirable than direct-connected machines, especially when the main shop engine has a large amount of surplus power, and our engraving shows a good example of this practice.

CAR BEARINGS—CENTER PLATE VS. SIDE BEARINGS.

At the May meeting of the Western Railway Club the subject of the bolster bearings for cars was taken up in topical discussion as follows:

"With the Very Heavy Capacity of Cars Now Being Built, Is It Not Advisable to Transmit the Weight from the Body Bolster to the Truck Bolster, Equally Distributed Between Center Plate and Side Bearings, Instead of Carrying All on the Center Plate?"

Mr. A. M. Waitt, General Master Car Builder of the Lake Shore & Michigan Southern Railway, opened the discussion and said:

Some weeks ago our chief engineer wanted me to take a trip to a certain point on our road and see why cars loaded with 50,000 or 60,000 pounds of coal, and started, would not continue down a grade of 45 feet to the mile and on straight track, too. I spent a forenoon in running loaded cars around curves and on this grade, and starting them down with a bar. Some of them went all the way down, and others only part way. The approach to the sloping track was a curve, and we found that all the older cars, especially those that

had trussed wooden bolsters instead of metal bolsters, for some reason or other the trucks would not straighten out after they had passed the curve; the flanges of the wheel pressed hard against the rail. You can at once see that under such circumstances, even after the cars were started with a bar, or were given quite a push with the locomotive, the friction between the car and the rail would be very great. There happened to be a rainstorm at this time, and the rail was somewhat slippery, which gave the cars all the advantage possible; yet we found car after car on which the trucks would not straighten out on the straight track. Later there were tried cars having metal bolsters, and the side bearings of which were in contact as well as the center plate, and yet those cars curved easily enough and went down on the straight track very readily.

The same condition must exist when we are hauling cars, loaded or empty, over the road, especially so when they are loaded. I think it is reasonable to suppose that we are expending a great amount of power trying to haul cars which, after they have gone around a curve, will not allow the trucks to adjust themselves properly to run on a tangent line.

Then came the question as to how a condition of that kind could be overcome. The first thing that would suggest itself would be to get the car up off the side bearings, and I examined car after car in going through the yard to see what condition they were in, and I think it safe to say that 999 cars out of every 1,000 are transmitting the load from the body bolster to the truck bolster through both center plates and side bearing. On many of the cars the proportion of the load transmitted through the side bearings is very large; I think it would be safe to say probably as great as is transmitted through the center plates, that depending a great deal on the original distance between the side bearings when the car is new, and also on the stiffness of the bolsters.

If it is attempted to carry the load entirely on the center plate, with large capacity cars, we are necessarily putting a very great strain upon the truck bolsters. It seems a reasonable conclusion, provided a side bearing can be so devised as to make the friction between the body and the truck side bearing practically nothing, or very small, that the ideal way of transmitting the load, considering the service of the truck bolsters as well as the freedom in the swiveling of the truck, is to have the load divided between the side bearings and the center plates. It will not do to carry the load on the ordinary center plate, and then have the ordinary cast iron or malleable iron or steel bearings in contact; the friction is too great, and after awhile, after the side bearings get rusty and the cars get somewhat out of shape and sagged more or less, the friction will be too great, as was the case with the cars I have examined.

Mr. Miller, Michigan Central Railroad—I think I may say that I stand almost alone in advocating swing bolster trucks for freight cars. I have always believed, and do believe, that if there is any advantage in using a swing bolster on a passenger car, there is a greater advantage in using the swing bolster on a heavy freight car. I think 90 per cent. of the cars of the United States have rigid centers for their trucks; I do not favor the rigid center truck. I have given this matter of side bearings a great deal of thought. There have been roller side bearings—a single roller with a trunnion; my observation has been that such bearings wear flat on top, and then they are worse than the ordinary side bearings. I have experimented with roller side bearings, and we are now experimenting with one which we think is correct in principle, and I believe that something of that kind will have to be adopted. Roller bearings must be made in such a way that the rollers must roll. In designing our latest one, which we have now under most of our passenger cars, and which can be seen under our coaches at the Twelfth street depot, we used an intermediate bearing, the cone-shaped rollers working between the bottom and the upper plate, centering to the center plate. A lever compels this intermediate plate to move, and thus compels the roller to move, and the roller then does not wear flat. I have had such side bearings on a passenger coach for six years, and I think that the principle is correct.

President Delano—Two cases have come to my attention of serious loss on account of too much friction between cars and the side bearings of the trucks. The first is in line of great damage to track and rail. In the case of a bridge across the Mississippi River the bridge itself is on a tangent for more than half a mile, but the approaches on each side are on a curve. It has been found that the rail on what would be the continuation of the outside of the curve is worn twice as rapidly as the other rail. The only explanation is that the trucks become slewed by the curve and do not straighten out when they reach the tangent.

The second instance illustrates the resistance to traction. Cases of switch engines stalling with a very small number of cars going around curves have frequently come to my atten-

tion. One case was so absurd as to seem almost untrue, which I saw myself only a week ago. A four-wheel switch engine, which I have seen handle forty loaded cars on a straight line, stalled with a full head of steam, pulling eight foreign box cars loaded with grain, coming out of an ordinary switch lead in a yard. I found that the cars were all overloaded, but not more than 10 per cent. beyond their capacity; but the whole trouble was that they were bearing down hard on their side bearings, the gage of the wheels on the axles was at the extreme limit, and the wheels were grinding so on the track that it was just like pulling the cars up hill to pull them around the curve.

Although Mr. Waitt makes the point that the weight of the cars should be divided equally between the center and side bearings, it certainly seems that if that is done, and so large a proportion of the weight of the cars is to be carried on the side bearings, then at least we must have a better side bearing than is now usual.

Mr. A. E. Manchester, C. M. & St. P. Railway—The ideal place to carry a car on the truck is at the center, with the side bearings only performing the office that they are intended for—that is, to take the sway of the car; and we should strengthen our body bolsters and our truck bolsters. It is not impossible that a durable side bearing that will meet these conditions can be designed, but I doubt whether anything has yet been devised that will stand the test of durability and cheapness and do the work. I believe that it is possible to build body bolsters and truck bolsters of such capacity that such side bearings will not be necessary. I furthermore believe that the condition mentioned by Mr. Waitt does not exist to the same extent with swing bolster trucks as it does with the rigid trucks; also that the swing bolster is easier on the body of the car, and, as a result, the car will last longer, will be racked less, and will be in general better condition after years of service than were the rigid truck used.

Secretary Whyte, C. & N. W. Railway—I want to say a word in favor of supporting the car on center plates rather than on side bearings. A number of years ago a certain road took the trouble to oil the center plates of its freight cars. The road was known as rather a crooked road, to be sure, but an effort was made to keep the cars off the side bearings and to further assist the trucks to assume their normal position readily the center plates were oiled, the car inspectors being provided with oil cans having spouts long enough to reach the center plates.

Mr. Waitt—There is one difficulty in making bolsters stiffer for the increased loads that are being put upon the cars, and that is that we are limited in the height of the couplers, and we are limited as to the height of the floor frame of the cars above the trucks to suit platform and places where cars are unloaded. If we transmit the load through the center plate and the side bearings we are not compelled to have as stiff a body bolster, and many of the old ones that we have in service would be sufficiently strong if, instead of concentrating the load in the center, we divided it between three points. We get a more ideal way of loading by equally distributing the load.

President Delano—Do you know whether it is the practice among roads with turntables to make the bearings of the turntables at the ends, or is it the practice, as I presume it is, to have all turntables bear entirely on the center, and have the ends free.

Mr. Waitt—I think the tables bear entirely on the center, with the ends free, for one reason, if for no other, that there is plenty of opportunity to provide sufficient depth to get the required strength.

Secretary Whyte—I think one of the difficulties of Mr. Waitt's proposition is that it would be rather hard to distribute the weight over six points. The weight can be distributed on two bearing surfaces, or on three, if the three bear the proper relation to each other, but it is difficult, without suitable equalizing arrangements, to distribute the weight over more than three bearing surfaces and insure that each gets its proper proportion; the bolsters would not be sufficiently flexible to insure this, I think.

Professor Goss—It seems to me we are attempting to design cars so that they will not bear on the side bearings, and yet are, in fact, unable to secure the desired result. In effect, therefore, the theory is one thing and the practical results quite another. I believe the theory is right, and that practice should be wrought up to the requirements. To support a car on side bearings means unknown stresses at every point of support.

New London, Conn., is to have the most extensive naval coaling station in the country. The largest coal sheds, piers and facilities for coaling war vessels are to be erected there immediately under the authority granted by Congress at its last session, when the sum of \$200,000 was appropriated for the work. The yard has been placed under the jurisdiction of the Bureau of Yards and Docks.

TESTS ON COVERINGS FOR STEAM PIPES.*

By C. L. Norton.

The apparatus for making these tests comprises several pieces of steam pipe of different diameters and lengths, heated electrically from within by means of coils of wire in oil. The oil is stirred vigorously and serves as a very efficient carrier of heat from the wires to the pipes.

In making a test the following operations are carried out, and observations are taken in the following order:

The current is turned on, and heat is generated in the wire coil until the wire, oil and steam pipe have reached the desired temperature at which it is proposed to test. The current is then gradually diminished until it is found to be of just the amount necessary to keep the pipe at this temperature without a rise or fall of 1-16 of a degree in 30 minutes. A reading of the voltage and currents is now taken at intervals of 30 seconds, and the watts and B. T. U. are computed from their average. We then have the number of B. T. U. lost from the outside of this particular pipe at this particular temperature. If now we place a steam pipe cover around the pipe, we shall find that a less amount of energy is sufficient to keep it at the required temperature, the difference being the amount of heat saved by the covering. It seems to me that I have approached

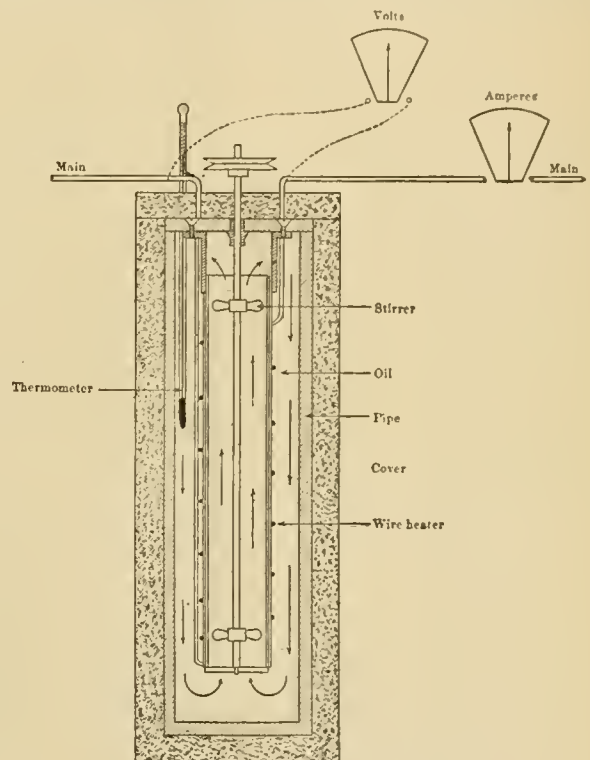

Apparatus Used by Prof. Norton.

more nearly the conditions of actual practice that can be obtained by any other method of testing, except the actual use of a long run of pipe; and the determination of the amount of heat put into such a pipe by the "condensation" method offers many difficulties and is open to much uncertainty. I feel, therefore, that in adopting this method I am using a reasonable exposure for the pipe, and have an exceptionally good opportunity to measure the heat supplied.

The money saving is computed on the following assumptions. Coal at \$4 a ton evaporates ten pounds of water per pound of coal. The pipes are kept hot ten hours a day three hundred and ten days a year. If computations are made, as is sometimes done, on an assumption that the pipes are hot twenty-four hours a day three hundred and sixty-five days in a year, the saving is nearly three times that shown in the table.

Generally speaking, a cover saves heat enough to pay for itself in a little less than a year at 310 ten-hour days, and in about four months at 365 twenty-four-hour days.

Specimen.	Name.	B. T. U. loss per sq. ft. pipe surface per minute.	Ratio of loss to loss from bare pipe.	Thickness in inches.	Saving per year per 100 sq. ft.
A.....	Nonpareil Cork Standard	2.20	15.9	1.00	\$37.80
B.....	Nonpareil Cork Octagonal.....	2.33	17.2	.50	37.50

*From a paper read before the American Society of Mechanical Engineers.

C.....	Manville High Pressure	2.33	17.2	1.25	37.20
D.....	Magnesia	2.45	17.7	1.12	36.90
E.....	Imperial Asbestos	2.49	18.0	1.12	36.80
F.....	W. B.	2.62	18.9	1.12	36.40
G.....	Asbestos Air Cell	2.77	20.0	1.12	36.00
H.....	Manville Infusorial Earth	2.80	20.2	1.50	35.85
I.....	Manville Low Pressure	2.87	20.7	1.25	25.65
J.....	Manville Magnesia Asbestos	2.88	20.8	1.50	35.60
K.....	Magnabestos... ..	2.91	21.0	1.12	35.50
L.....	Molded Sectional	3.00	21.7	1.12	35.20
M.....	Marsden Infusorial Earth	3.11	22.5	1.00	34.85
N.....	Marsden Infusorial Earth.. ..	3.27	23.7	1.00	34.60
O.....	Asbestos Fire Board	3.33	24.1	1.12	34.20
P.....	Calcite	3.61	26.1	1.12	33.24
	Bare Pipe	13.84	100

By the advice of the members I have made an assumption that the cost is not nearly proportional to the thickness. As the thicker coverings are not now made in great quantities, the actual cost of their manufacture is uncertain.

TABLE V.
VARIATIONS IN THICKNESS, ETC.

Specimen.	Saving in B. T. U. per sq. ft. per minute.	Saving in dollars. per 100 sq. ft. per year.	Net saving.				Approximate cost.
			1 year.	2 years.	5 years.	10 years.	
Magnesia:							
1 3/8-inch thick.....	11.62	\$37.75	\$7.75	\$45.50	\$159	\$347	\$30
Magnesia, 1 3/8-inch thick and 1 inch of hair felt	12.38	40.22	5.22	45.44	166	367	35
Magnesia, 1 3/8-inch thick and 2 inches of hair felt	12.77	41.50	1.50	43.00	167	375	40
Nonpareil cork							
1 inch	11.64	37.80	12.80	50.60	164	353	25
2 inches.....	12.84	41.75	7.75	48.50	174	383	35
3 inches.....	12.94	42.05	7.95	34.10	160	370	50
Fire board:							
1 inch	10.54	34.20	9.20	43.40	146	317	25
2 inches	11.48	37.25	2.25	39.50	151	327	35
3 inches	11.70	38.00	12.00	26.00	140	330	50
4 inches	11.83	38.40	26.60	11.80	127	319	65

Inspection of Table V. shows the saving due to the use of hair felt outside a standard Magnesia cover.

In five years 100 square feet of hair felt saves \$7 more than its cost, and in ten years it saves \$20 above its cost. The further saving due to a second inch outside the first

CONVENIENT PNEUMATIC APPLIANCES—CHICAGO PNEUMATIC TOOL COMPANY.

In our July issue we gave an outline description of the new tools introduced by the Chicago Pneumatic Tool Company, and now present engravings of three devices which have proved themselves to be especially valuable in machine and boiler shop equipment.

Car and Locomotive Jacks.—The design of these jacks is very simple, not differing in essentials from others that have been in use in railroad shops for some time. They are compact and are well made and well finished from good material. The cylinders and heads are of cast iron, with bolted machine joints, and the pistons are of cast iron, with leather packing. The piston rods are of steel, surmounted by bearing blocks that are free to turn on the piston rods. The air pipe connection is made through the upper head, and the pressure is controlled by a cock. The capacity now ranges from 5 to 25 tons, several of the latter having already been ordered. Trunnions are cast on the cylinders and the jacks may be carried about on a neat two-wheel metal truck, which will fit the trunnions of all of the jacks. The design is arranged with a view of producing jacks that may be easily used and conveniently transported, and which will not require repairs.

Bolt and Staybolt Nipper.—This appliance is so clearly shown in the engraving as to be readily understood. It has a short cylinder between the long arms of two levers, the short arms of which are fitted to receive the hardened cutters. The long arms are returned to their closed position by strong coiled springs, attached to the outside of the levers, where they may be seen and cared for. The nipper is suspended by a bail with a number of holes by which it may be held in any desired position. The machine is adapted to work in restricted quarters. These machines are well made and may be easily taken apart for overhauling. They work rapidly and are controlled by a lever operating a

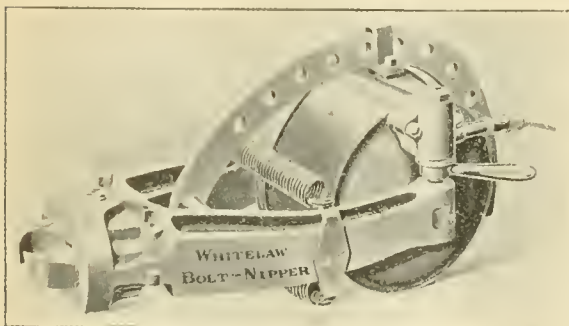

Whitelaw Staybolt Nipper.

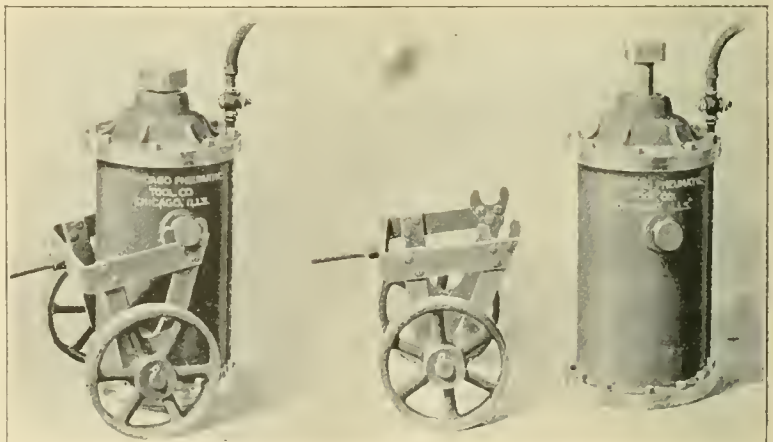

Car and Locomotive Jacks.

is \$8 in ten years. Of course, the well-known tendency of hair felt to deteriorate should be considered.

In the case of Nonpareil Cork, increasing the thickness from one to two inches raises the cost from about \$25 to \$35 per 100 square feet, and increases the net saving in five years by \$10 and by \$30 in ten years. In other words, the second inch of material in use about pays for itself in two years, while the first pays for itself in about one year. The third inch does not increase the saving even in ten years. The second inch, therefore, more than pays for interest and depreciation, while the third fails to do this.

In the case of the Asbestos Fire Board, a second inch in thickness causes a saving of \$20 in ten years, the third and fourth inches showing a loss.

In general it may be said, therefore, that if five years is the length of life of a cover, one inch is the most economical thickness, while a cover which has a life of ten years may to advantage be made two inches thick.

valve at one end of the cylinder, shown in the engraving. Two sizes are made. No. 1 will cut bolts up to 1 inch in diameter, and No. 2 will cut bolts as large as 1 1/2 inches. Their capacity is limited only by the ability of the operator to move them to the work.

Pneumatic Flue Welder, Reducer and Expander.—This machine is a combination of devices perfected and improved from the original devices known as the McIntosh flue welder and the Wimes flue reducer. They are combined on one bed plate that may be bolted to the top of a small post in the shop, the only power connection being a single piece of rubber hose. Shafting being avoided, the machine may be set up anywhere, and the air pipe carried to it. The machines are very ingenious; they are well and strongly built, and are automatic in the sense that the introduction

of a flue to its proper position for working opens the air valve, and the operator has only to place the flue in position and turn it until the work is done; when withdrawn the air valve closes and the machine stops. The work is done by reciprocating hammers driven by pistons controlled by ingenious tappet valves, which admit and release the air from the cylinders very rapidly. It is a compact combination, and if desired the welder and reducer may be mounted separately, and the reducer may be used in connection with other forms of welding machines if desired, although we should think the two ought to be used together. The machine is usually placed near the heating furnace, and the capacity is limited only by the dexterity and skill of the operator. As many as 300 flues have been reduced in an hour, and as this work may be done after the welding and at the same heat the convenience of the machine will be clearly understood. It is stated that this reducer when used with the Hartz welding machine will save from 3 to 5 hours on a single set of flues. The dies may be changed in a few minutes. Reheating and

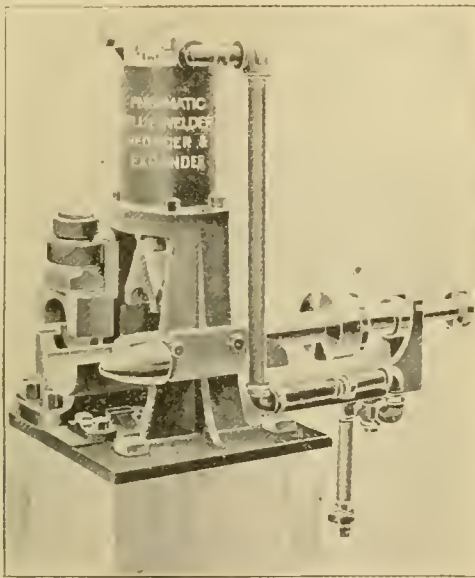

Pneumatic Flue Welder, Reducer and Expander.

handling are saved, which means very rapid and cheap work. They will weld and reduce a flue in about 8 seconds when operating under a pressure of 40 pounds per square inch. The pressure is reduced by reducing valves before the air passes into the machines.

There is nothing more awkward than the arrangements for flue work as we have seen them in many railroad shops, and this compact outfit, with its labor-saving possibilities, cannot fail to make a mark on flue work. In writing us recently about the operation of this machine, Mr. McIntosh, Master Mechanic, C. & N. W. Ry., said:

"It was originally designed for welding alone. Later Mr. Whomes attached an auxiliary hammer and dies for reducing, and, finding it a success, designed an independent reducer that can be used in connection with other machines, the Hartz, for instance, reducing the flue at the same heat that welds it. We find these machines reliable and durable and remarkably rapid. It takes but five seconds to weld and reduce a flue. Consequently, the heating furnace regulates the output. We use the Ferguson oil furnace, a very excellent heater, but the flue welder and reducer would easily keep three of them busy. Both machines are automatic, starting in motion only when the flue is placed under the dies and stopping instantly on its withdrawal, using air but a few seconds at each operation and economizing power to the greatest degree. Other advantages are cheapness and small floor space required."

THE MICROSTRUCTURE OF BEARING METALS.*

BY GUILLIAM H. CLAMER,
Chemist to the Ajax Metal Company, Philadelphia.

The science of microscopic metallography is at present attracting widespread attention, and great developments have of late resulted from this mode of testing. Microscopic examination is fast becoming a factor in testing metals. In the study of iron and steel much work has been done and much information obtained; but the microscopic examination of alloys is a comparatively new piece of research. Chemical analysis can show only the composition of an alloy; but to show the true structure, or manner in which the component parts are alloyed, is left for the microscope. The physical properties of a sound piece of steel depend exclusively upon its chemical composition and upon its structure, and just so with all other alloys; not only should the component parts thereof be known, but also the manner in which these metals are alloyed, as is shown by their structure. We may take, for instance, bearing metals. In these alloys two all-important points requisite to a good bearing alloy, namely, anti-friction and wearing qualities, are greatly dependent upon structure.

It is, of course, first necessary to have the composition correct to meet certain requirements, such as load, speed, etc., and then to have the component parts alloyed in such a manner that the product shall be as fine-grained and homogeneous as possible. The failure of many bearings to give satisfactory service is more often the result of improper mixing than of a poor composition.

It is an undisputed fact that certain combinations of metals are better than others, but it frequently happens that an alloy of good composition is far inferior to another of poor composition, simply on account of improper manipulation; a good composition in the hands of unskilled foundrymen often yielding a granular and uneven mixture of very inferior quality, while a good metal can be made of inferior scrap by another.

How the wearing qualities are dependent upon structure will be made evident when we consider the definition of wear—"the tearing off of small particles from the worn bodies." Therefore, a bearing metal which is finer in granular structure will wear the slower because of the tearing off of smaller particles.

If a metal is not homogeneous, the anti-frictional qualities will suffer greatly, because of the difference in the hardness and density of the metal in all its parts. The particles of such an alloy form hard spots within the metal, which produce friction.

The homogeneity is greatly dependent upon the treatment the alloy has undergone, and a perfectly even structure can only be obtained by careful and proper treatment.

In view of these considerations, I was led to make a study of the structure as well as the composition of the various bearing metals on the market in this country, and more particularly those which are used in railroad service.

The question as to what is the best metal on which to run our rolling stock is one which is becoming more important every day. We are running our trains on faster schedule; we are increasing the size and weight of locomotives and cars to acquire greater speed, greater carrying capacity and greater comfort.

Only a comparatively few years ago railroad men would have laughed at the idea of attaining the train weights and speeds of to-day. They would have advanced a hundred difficulties in the way of achieving such wonderful results, and chief among these would have been cited the difficulty of obtaining a bearing metal which would meet these requirements. In former times, when speed was not attained and comfort but little considered, a "hot box" was of little consequence; but now the numerous trains are required to dash along with marvelous regularity, reaching their destination after a run of hundreds of miles on the very minute they are scheduled to arrive. Under these conditions even the slightest delay often leads to the most disastrous consequences. Many accidents are on record which can be traced to a hot box.

Apart from the safety and successful movement of trains, which can be accomplished only by the use of well-fitted, well-lubricated bearings, composed of a properly made anti-friction alloy, the question of cost is also an important factor—not only first cost, but also the expense which is directly dependent upon the wearing qualities of the alloy and its successful use as scrap. A metal to be successfully used as scrap must have the quality of not deteriorating in remelting. The importance of these considerations is at once obvious to a well-regulated railroad, which considers the great loss occasioned by wear, and the necessity of converting their scrap again into a first-class journal brass.

The alloys now in use for this purpose may be divided into five classes:

(1) White metal alloys; (2) miscellaneous alloys; (3) copper and tin alloys; (4) phosphor-bronze; (5) copper, tin and lead alloys.

Cast iron has been tried as a journal metal on railroads, and in fact was used for some years, but I think that it has now been entirely abandoned for the composition metals. Roller bearings have also been experimented with, but, so far as I am aware, have failed to give satisfaction.

The preparation of these alloys for microscopic examination is, of course, of first importance. They must be carefully polished and then etched with a suitable reagent. For copper

*A paper read before the Franklin Institute.

alloys I prefer to use the method of Guillemin, i. e., to attack the specimen electrolytically by exposing it for a few minutes in a bath of very dilute sulphuric acid when connected with a simple Daniel cell, and, in making a comparative study of metals of similar composition, all the conditions must be the same. The method I use is to make a platinum dish, containing the weak acid solution, the positive pole, and then immerse the specimens to be compared in the solution in contact with the dish, and pass a current through them all at the same time.

The white metal alloys belong to the first class. They are first in anti-frictional qualities, but do not wear well, and, furthermore, have not sufficient strength to support the great weight of locomotives and cars without distortion or crushing. The practice, therefore, is to use these metals inside of a stronger shell of composition metal.

In car bearings these soft alloys are simply used as a lining, which is not more than 1-16 to 1/8 of an inch in thickness. The object of this lining is to give the bearings a good seat without having to be bored out accurately to fit the diameter of each individual axle. The diameters of the axles vary according to the wear they have had, and to fit hard-metal bearings it would be necessary to bore each one to fit each particular axle, and, moreover, the axles are always more or less rough. The soft white metals easily conform to any such irregularities in the surface of the axle.

This soft composition soon wears away, but by the time this has taken place the bearing has a good seat on the axle, thus doing away with the necessity of fitting each separate journal. The boxes are all bored out to the same diameters and lined with a specified thickness of soft metal. In this way the bearings are all fitted with minimum expense and confusion. The principal alloy used is one containing antimony and lead; this is sold on the market under the name of "hard lead." It usually contains from 15 to 25 per cent. of antimony, which makes the alloy coarsely crystalline and brittle. It is inexpensive, but gives little wear. Although antimony is a more expensive metal than lead, the "hard lead," or antimonial lead, sells at a lower price than pure lead. The microstructure shows these coarse crystals (Fig. 1). With the increase of antimony the crystals are brought into closer contact, indicating the approach to the chemical alloy. Tin greatly improves this alloy. It gives it greater toughness, and makes an alloy which will stand a much greater pressure without distortion—a valuable feature for a babbitt metal.

This is the composition of nearly all the cheap babbitt metals on the market. A good babbitt metal should have as fine a grain as possible in connection with the greatest toughness and hardness obtainable. Tin has the property of greatly reducing the granular texture of antimonial lead. Bismuth in small quantity is added to the lead, antimony and tin alloy by some manufacturers. It is claimed to give greater fluidity and less distortion under pressure. The composition of such an alloy is:

Lead	80.00
Tin	4.75
Antimony	15.00
Bismuth25

The question of obtaining a fine-grained structure depends greatly on the method of manufacture, temperature of pouring playing an important part, but generally the size of the crystals increases with the increase of antimony, as does hardness; but by proper manipulation a finely crystalline metal can be obtained in an alloy of the following composition, which has a high percentage of antimony, thus making it a valuable babbitt metal:

Lead	70.00
Antimony	20.00
Tin	10.00

The first white metal successfully used as a bearing metal was invented by Isaac Babbitt. It contained tin, antimony and copper. This metal is used for lining purposes, but can be cast into solid bearings which do not carry too great a load. All white metals used for bearing purposes are now sold under the name of babbitt metal, and when used as a lining the bearing is said to be "babbitted." But to distinguish this metal from the cheaper lead alloys it is sold under the name of "Genuine Babbitt." This alloy is harder than the lead alloys, much tougher, and is finely crystalline and wears well. It is much more expensive, owing to the content of tin. The composition is as follows:

Tin	80.00
Copper	10.00
Antimony	10.00

Another alloy very successfully used is one composed of:

Tin	68.00
Zinc	31.50
Copper	1.00
Lead50

It is very tough and bends many times without breaking, due to the peculiar interlocking of the crystals (Fig. 2). It has, however, the bad feature of pouring sluggishly. I have no knowledge of the wearing qualities of this metal.

I will next consider the miscellaneous alloys. Under this head may be included any alloy, it matters not what the composition, so long as it produces a reasonably good casting. It includes all alloys having over 60 per cent. of copper and the remainder made up indiscriminately of zinc, tin, lead, antimony and any other metals which happen to be in the scrap pile.

Such compositions as these are used on freight cars, and, indeed, by some roads in passenger service, their only aim being to get a cheap composition. No attention is paid to wearing or other qualities, and the running expense is not taken into account; it is only first cost. If a bearing gets hot or wears out,

it is removed and thrown into the scrap pile, to be again remelted. Foundrymen receiving this scrap term it all "red brass," and without any knowledge of the composition again convert it into journal bearings.

The scrap pile always contains more or less zinc, and indeed anything from yellow brass up is considered good enough for a cheap bearing metal.

Fig. 3 shows the structure of yellow brass of:

Copper	66 2-3 parts
Zinc	33 1-3 "

It is beautifully crystalline and the size of the crystals varies greatly with the method of treatment. Zinc has the property of giving greater solidity to alloys of copper, tin and lead, 1 to 2 per cent, being sufficient for this purpose, and when more than this is used in connection with other scrap the effect is more or less injurious. If the scrap metal coming from the railroads was first melted and run into pigs and analyzed, uniform results could be obtained by building up the scrap with new metal to the desired composition; but the present low price of such material would not warrant this extra expense; and, indeed, I have known of such bearings to be cast, bored out and lead-lined for 7 1/2 cents per pound. But even so, with proper care, a fairly good metal can be made from such scrap.

Fig. 4 shows a bearing metal made of scrap which has been carefully treated; it contains a high percentage of lead, but shows no liquation of the lead, as would be expected in an alloy of this nature.

Fig. 5 shows a copper and tin alloy, containing a little lead, in which manganese has been used as a deoxidizer.

The alloy of copper and tin some years past was considered the standard bearing metal on railroads, but is now little used. These metals alloy to form a very hard and crystalline alloy (Fig. 6), the usual proportion being that of cannon bronze—7 parts of copper to 1 part of tin. Although this alloy is much harder than the standard metals of to-day, yet it is found to wear much more rapidly and produce more friction. Dr. Dudley, chemist to the Pennsylvania Railroad, some years ago gave the results of a long series of experiments before the Franklin Institute, in which he compared the copper and tin alloy with the standard phosphor-bronze, which contains lead. He found that the copper and tin alloy was much more liable to heat under the same state of lubrication than the standard phosphor-bronze, and second, that the rate of wear with the copper and tin alloy was nearly 50 per cent. greater than that of the standard phosphor-bronze. And still, in spite of these facts, some railroads still go on in the old way specifying copper and tin, a more expensive alloy than the phosphor-bronze, or the copper, tin and lead composition.

These experiments led directly to the use of standard phosphor-bronze bearing metal on the Pennsylvania Railroad, and indirectly to its use of other large roads. Thus, by practical experimentation and experience, railroad men to-day recognize but two alloys as standard: (1) Copper, tin and lead alloy, containing phosphorus, known as phosphor-bronze. (2) Copper, tin and lead. I do not say that either of these alloys is the best that can be devised, but up to the present time, and with our present knowledge, they are the best compositions for car and locomotive journal bearings. As far as wearing is concerned, I do not think the phosphorus introduces any advantage, and, as Dr. Dudley says, he has no evidence to show that the phosphorus has any other use except to produce sound castings.

I had occasion very recently to find, by a practical test, that the alloy of copper, tin and lead gave better results, so far as anti-frictional qualities are concerned, than the alloy containing phosphorus. That the bearings without phosphorus showed a much less tendency to heat than the phosphor-bronze was clearly demonstrated. The test was made by placing the phosphor-bronze on one side of the axle and the simple alloy on the other. The tests were strictly comparative in every way, and the number of hot boxes of the phosphor-bronze metal greatly exceeded the simple alloy. And it has been found, by practical experience, that remelted phosphor-bronze is much more liable to heat than the newly-made metal.

In order to discover why the remelted scrap phosphor-bronze should be inferior to the newly-made material, I determined to make some experiments in a practical way. The fact that the phosphor-bronze scrap is far inferior to new metal is well known, and I believe the general impression has been that the inferiority was due to the burning out of the phosphorus, as it is for this reason that the specifications of standard phosphor-bronze call for a high percentage of phosphorus, in order to make provision for loss in remelting, and with the idea that the remelted scrap will still retain sufficient phosphorus not to deteriorate its qualities. By my experiments I find this to be an entirely mistaken idea, because, in the first place, phosphorus only burns off in very small proportions, when once thoroughly contained in the alloy; and secondly, that the inferiority of the metal is directly due to the high percentage of phosphorus, for the reason that it combines with the tin and copper to form hard crystalline phosphides, which are, to a great extent, dissolved in the alloy when the metal is new, but separate or crystallize out in the old material.

Six hundred pounds of phosphor-bronze was made of good selected material, and every precaution used in manipulating. It was then poured into ingots and borings taken from the first, middle and last ingots, and the borings mixed and analyzed. The analysis showed:

Copper	78.72
Lead	9.82
Tin	10.53
Phosphorus	1.04

Three hundred pounds of these ingots was now weighed off and remelted, and again poured into ingots and weighed, and the loss carefully noted; the metal being melted and poured in this way ten times, and the loss noted in each heat, with the following results:

	Pounds.		Pounds.
1st	3.5	6th	2
2d	3.0	7th	3
3d	3.0	8th	3
4th	2.5	9th	4
5th	3.5	10th	7

The total loss was 34.5 pounds, or 11.5 per cent., on ten heats, and the average loss per heat 1.5 per cent. It will also be seen how uniform was the loss on every heat; the last heat only showing considerable deviation, which I attribute to the metal being insufficiently hot to flow cleanly from the crucible. Borings were taken from the first, middle and last ingots of

	Pounds.		Pounds.
1st	7	6th	4
2d	3	7th	2
3d	1	8th	3
4th	4	9th	3
5th	4	10th	3

This metal became harder and closer-grained after the repeated meltings, but showed no signs of becoming crystalline or granular.

Fig. 9. New copper, tin and lead alloy.

Fig. 10. Remelted copper, tin and lead alloy, made by the Ajax Metal Company's process, which insures the homogeneous distribution of the lead.

Many alloys of copper, tin and lead are manufactured by foundrymen under the name of anti-frictional metal, and are sold under various well-sounding names, which are supposed to indicate their qualities.

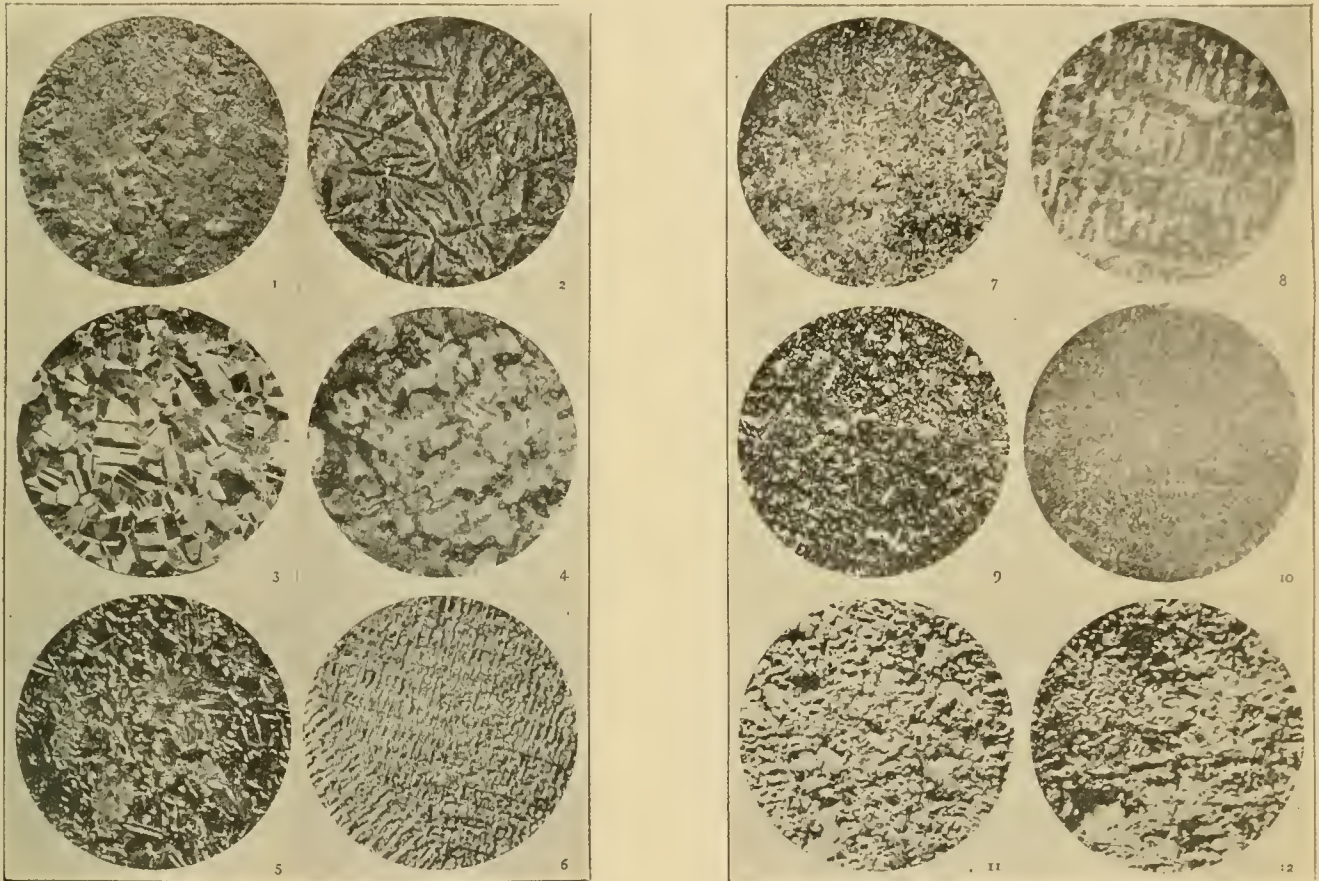

Figs. 1.—Antimonial lead. 2.—Tin and zinc with little copper and lead. 3.—Copper and zinc. 4.—Copper, zinc, tin, lead, iron. 5.—Copper and zinc with little lead (manganese used as deoxidizer). 6.—Copper and tin. 7.—Copper, tin, lead and phosphorus (1st melting). 8.—Copper, tin, lead and phosphorus (after repeated meltings). 9.—Copper, tin and lead (1st melting). 10.—Copper, tin and lead (after repeated meltings). 11.—Copper, tin and lead, showing liquation of lead. 12.—Copper, tin and lead, showing liquation of lead.

Diagrams Made from Magnified Sections.

the tenth heat, well mixed and analyzed. The metal now contained its constituents in the following proportions:

Copper	30.39
Tin	10.40
Lead	8.35
Phosphorus	.87

The analysis shows that very little phosphorus has gone off, despite the fact that the metal was melted and poured ten times, the lead showing the greatest loss. The following table will show the loss in weight very closely, as shown by the analysis:

	1st Heat.	10th Heat.	Loss In Pounds.
Copper	235.47	213.41	22.06
Tin	29.67	27.61	2.06
Lead	31.74	22.17	9.57
Phosphorus	3.12	2.31	.81

These results show that the phosphorus is held in bronze in the form of phosphides, which high temperature can drive out only in very small proportions. The metal under the microscope was now decidedly crystalline. These crystals are intermixed or held dissolved in the new metal, but when subjected to remelting become organized and crystallize out in the alloy, thus greatly reducing the anti-frictional and wearing qualities of the metal. The resulting metal after the tenth heat was so hard it could scarcely be touched with a file.

Fig. 7. New phosphor-bronze.

Fig. 8. Remelted phosphor-bronze.

A copper, tin and lead alloy of the same composition was treated in the same way; the loss on this metal was 34 pounds, being within half a pound of the phosphor-bronze, and the loss on each heat was as follows:

To one who is unacquainted with or does not consider the chemical and physical properties of lead, it appears an easy matter to make such an alloy by merely melting in a crucible the three metals in the stipulated proportions; but when we consider the greater density, the lower melting point, and the slight affinity of lead for the copper and tin alloy, a more serious question results. I have found, by my repeated microscopic examinations of many such alloys of different makers, that lead is in no instance combined or really alloyed with the copper and tin, or perhaps only in small proportions, probably not over 1 per cent.; the remaining lead being held diffused through the alloy in its combined state, or with small proportion of the tin and copper, but not enough to destroy the grayish-blue color.

Such an alloy under the microscope is seen to be made up of two principal colors, the bronze-colored combined copper and tin, and the grayish-blue lead. Now, this being the case, it will be seen how difficult and also important it is to obtain an alloy which will show the same structure and percentage of lead in all its parts. The difficulty in obtaining such an alloy is this, as I have stated:

(1) The lead is not combined with copper and tin.

(2) Owing to the high specific gravity and the lower melting point of the lead, its tendency is to go to that part of the casting which has last solidified, or to distribute itself unevenly throughout the mass.

I will now show the structure of copper, tin and lead alloys of several makers; they all have about the same composition and were all cast in the same size bars, great care being taken to have the conditions as nearly alike as possible. A section was cut out of the middle of each bar for examination.

Fig. 11 shows the structure of an alloy of the following composition:

Copper	76.88
Tin	19.62
Lead	11.71

It shows that the lead has liquated, leaving an unsound metal. The dark spots are holes and the lighter particles lead. That such a segregation of the lead greatly reduces the value of a composition of this nature is very evident.

Fig. 12. A metal of following composition:

Copper	76.66
Tin	11.68
Lead	10.83

This shows a still greater segregation of lead. In this metal the lead is very unevenly distributed, it having formed large pools through the alloy.

Of all metals, lead is by far the first in anti-friction qualities; and if to the strength of copper and tin there is added a suitable proportion of lead, thoroughly and evenly distributed throughout the mass, the bearings as they wear are constantly in contact with soft anti-friction particles of lead, which are backed by the harder particles of copper and tin. If in such an alloy the lead is not homogeneously distributed and without liquation, both the wearing and anti-frictional qualities are greatly affected.

After going through the whole subject of the composition of metals suitable for bearings, the thoroughly homogeneous alloy of the proper portions of copper, tin and lead seems to me to be best suited for the purpose, and this has also been demonstrated in actual service by the use of such alloy on all the record-breaking trains of recent years, notably the New York Central & Hudson River flyer from Albany to Buffalo, which made the run of 436½ miles in 407 minutes, with the bearings perfectly cool throughout the entire run; and on the fleetest ocean greyhounds that cross the ocean.

The alloy of copper, tin and lead, of proper composition and homogeneous structure, I think I am safe in saying, has greater anti-frictional qualities than any other composition of sufficient strength to be used as a journal brass in railroad service. This fact has been demonstrated several times by actual practical tests, and, furthermore, it does not deteriorate in remelting.

As structure is of such importance in a bearing metal, I think the micro-test should be included in all specifications as equal, if not greater in importance than chemical analysis.

ADVANTAGE OF IMPROVED TOOLS FOR RAILROAD SHOPS.*

We find that where a careful selection and proper application has been made of improved tools in shops the saving in time over the old methods of getting out the same class of work is so great as to set aside all doubt and beat down all prejudice heretofore existing in the minds of a few mechanical men who are loth to depart from old and tried ways. Your committee finds that the introduction of truly improved tools for meeting special railway repair shop work has been slow, considering the great advantages derived from their use, and from facts ascertained in making our inquiries, we are satisfied that a large majority of our master mechanics are not reading upon or keeping posted with the progress made by some of their brothers in this important line, or if they are, then their managements fail to appreciate their efforts, or act upon their suggestions.

As your committee on the subject of motors, in their full and complete report at our last convention covered this field so well, we decided not to touch to any extent upon this part of what is considered by many as pertaining to our subject of improved tools; at the same time we want to emphasize and indorse all the committee suggests and to add that even since their report was submitted rapid strides have been made in the invention and introduction of powerful and convenient motors having electricity and compressed air to actuate them and with the advantages of being adapted to special or universal service which enables them to cover almost every variety of work for which detached or independent motion is desirable, and the extended use of them in connection with the latest improved tools designed to work with them is strongly urged by your committee. The great improvement made in heavy shop tools and the very successful efforts to introduce features in them for wider scope and greater capacity is familiar to all who have looked into the subject, and your committee assumes in the matter of heavy lathes, planers, slotters, shapers, etc., that all interested are posted, and we propose to confine our report to the more special tools, those gotten up with a view of dispensing with all work formerly done by hand where possible to machine it.

These are the great labor and time savers, and consequently do as much, and in some cases more, to reduce cost of repairs on locomotives than the heavy tools, and, strange to say, they have received but little attention in proportion to their worth, if we may judge from the lack of general introduction. These consist in part of milling machines, vertical, horizontal and universal, turret lathes of special design, special brass lathes, grinding machines, tool sharpening devices, cold sawing and cutting off machines, threading machines for turned bolts, etc., to dispense with cutting threads on lathes, and some of the latest designs of light shapers, slotters and quick return planers.

Possibly the most important of the improved tools are the latest designs of milling machines. With these we are enabled to machine almost any part of locomotive machinery that cannot be handled in our lathes and planers, and also finish and fit

parts that could only be done by hand heretofore, and owing to their ease of adjustment we are enabled to design work to be machined by milling very cheaply that would have been difficult if not impossible to handle in any other machine. A visit to some of the large building shops where heavy milling machinery has been so generally introduced would be quite a revelation to those who have failed to keep up with the subject. There seems to be no limit to their usefulness, and but few, if any, jobs arise in ordinary practice that cannot be handled in a well designed milling machine. Your committee finds that the introduction of light milling machines years ago, which could be used only for cutting gears, fluting reamers, taps, etc., and which proved too small to be of any general use, had the tendency to prejudice many shop men against them, and the fact that only recently such machines as are calculated to take the place of planers, slotters and other tools have been available, has no doubt had much to do with the slowness of shop managers to take hold of them, but now that it is possible to select a machine to suit your work we strongly recommend their use, and find that a saving of at least 20 per cent. over the ordinary planer can be obtained where a heavy milling machine is worked up to its full capacity on most work.

Perhaps the next most important, if not equal, adjunct in the way of improved tools for machine shop is the turret lathe. These tools are now made very strong and heavy, designed to cover a large variety of work, and for nearly all kinds of turning from the solid bar.

With a properly built turret lathe not only are bolts for engine work, but all pins, bushings, collars, etc., for any description of machinery, etc., can be rapidly produced, and accurately duplicated. The attachment for threading makes them much faster and more accurate than the old method of threading in ordinary lathes. Your committee recommend none but the best and heaviest turret lathes. There are many on the market like the poor milling machines, and not worth the room they occupy. Too much care cannot be exercised in selecting what are considered improved tools for shops, and this applies with great force to tools for railroad shops, where we cannot afford many, if any, costly special tools, but must confine ourselves to purchasing such improved, or even ordinary machines, that are as universal as possible in their action. We find that with the best designs of turret lathes in the hands of smart and intelligent operatives who adapt the machines to the work in hand, and work them to full capacity, that a saving of from 45 per cent. to 55 per cent. can be obtained in all kinds of bolt and pin work, over the ordinary methods of doing this work in lathes.

Your committee finds that great improvement has been made in the machinery for handling brass work in shops, and, notwithstanding we are constantly trying to reduce, or dispense with connections and attachments as far as possible, we still have a large number of brass and other metal fittings to produce, and shops that are prepared, or desire to make their own oil cups, gauge cocks and standard brass fittings, would do well to look into the matter. Many of the best of these machines will lessen the cost of production of this class of work at least 50 per cent., and the output is far superior in fit and finish, owing to the arrangements for accurate duplication. There are now available several makes of quick return high speed planers and shapers for light work designed to keep all small jobs out of the heavier tools, and where a shop is confined to two or three planers, all of them probably 36 inches or over, with one or more heavy shapers, one of these machines will be found not only very convenient, but most profitable. They handle rod keys, liners, keys for frames, etc., and for quick time on brass work of all kinds, are indispensable. These newer designs are small, but heavy and compact, and should not be confounded with the flimsy little machines so generally on the market, with which all shop men have become disgusted, owing to poor design, extreme lightness and uncertainty of feed, etc.

Your committee is pleased to note the more general tendency on the part of many shop men to take advantage of the suggestions made and points given on this subject in our former reports of committees on this subject. It encourages us to hope our efforts are appreciated, and that good is being done by the Association's action in keeping this most important matter to the front. This is especially apparent in the number of pneumatic and electric motors in use, and particularly the former. We find but few shops who now depend upon the old ratchet for drilling and reaming, and the number of belt and rope conveyors, and old-fashioned devices for obtaining motion, are growing less every day. We find that where compressed air is being used in connection with the best motors for drilling, reaming, boring, tapping, chipping, calking, screwing in stay bolts, riveting tanks, ash pans, and many other uses, that the average saving over the old hand methods is from 35 to 40 per cent., and on some jobs, is over 50 per cent., particularly in drilling shops where ratchets were formerly used. The average saving in boiler shops fully equipped with good pneumatic tools to cover all lines where they have proven an advantage is about 50 per cent., and by some who have given the matter much thought is considered much above this figure when great saving in time engines are laid up for boiler work is counted. We find fewer improvements in our blacksmith shops than in other departments of railroad works, the old methods prevailing in them to a much larger extent than in others, and we suggest to our master mechanics, and foreman blacksmiths, to go around, or write for particulars as to what is being done in this line at some of our leading railroad shops, those of the Union Pacific at Omaha, the Santa Fe at Topeka, and many others, having introduced compressed air with great results on certain work.

Outside the shop proper, in the yards and buildings for storing material, scrap iron, is a great field for saving labor by conveniently arranged pneumatic lifts and motors, many foremen

*Report before the Master Mechanics' Association, June, 1898.

being able to do with two or three men what kept ten or a dozen busy, such as loading and unloading wheels, tires, boiler plate, heavy castings and lumber. In addition to the saving in time, the liability to accidents to employees is greatly lessened by the safer and surer manner of handling and the fewer men employed. Your committee could not procure figures showing the relative economy of these yard appliances, but their ultimate saving must be apparent to all.

We find a great improvement in many of the wood working machinery departments of our railroads; this is particularly true of those shops who build a part of their new equipment; the improvement in planing and matching machines, borers, mortisers, sawing machines, and, in fact, all wood working machinery has been so rapid in the past few years as to be a question "if it would not pay many roads to dispense with the whole of their antiquated old plant and replace it with just half as many well selected tools designed for their work, that would turn out more work in a day than they now get out in a week?"

Before concluding our work on this subject, we desire to call the attention of our Association to a few things that have struck us most forcibly while inquiring into the matter. First, the great difference existing in the methods of prosecuting work even on our improved tools in the average railroad shop, as compared with a well organized and hustling manufacturing establishment in about the same line of business. The factory producing for the market to make a profit seems actuated throughout by a different impulse from the average railroad shop, even where piece work has been long established, and none of the railroad shops seem able to get quite as much advantage of their special improved tools as is accomplished in the factories—in other words, they are not worked up to their capacities as continually. We have, of course, made due allowance for the difference actuating the employees, and the difficulties to be met by foremen and others in our railroad shops, and we simply mention this in connection with the economy of improved tools.

Second—In some shops we found milling machines that were idle which could have been well adapted to many kinds of work being done in planers, shapers and slotters; these would have been greatly relieved and much other work done in them that the mill could not handle by proper management and suitable cutters being provided for the mills. No pains should be spared to provide every device for utilizing the milling machine to its fullest capacity and keep it going all the time. When once realized its great usefulness cannot be overlooked, and its place is never filled by any other machine.

Among other improved tools that seem to contribute largely to the increased output of such shops as have taken advantage of them are the cold sawing machines; these are used for cutting off machines, and also for cutting to given lengths all kinds of shapes, rounds, squares, flats and ovals of almost any section, evening up channels, tees, angle irons, etc., and also cutting them to given lengths with great ease and rapidity as compared to old methods. These machines are also indispensable in the building of iron and steel tender frames, trucks, etc., and for the boiler maker they supply a long-felt need, while they contribute to every department around a works; none but the heaviest and best should be introduced; the great scope of their work entitles them to the closest consideration in selecting shop plants, and we invite special attention to them. A reasonable estimate of their saving over old methods is about 35 per cent. to 50 per cent., according to character of work to be done, and with them all cross sections, such as are met in tender frame construction, are made perfectly.

We have not touched upon shop cranes as yet. We almost hesitate to do so, as so few ordinary repair shops are able to provide them; at the same time we all admit the desirability of their extended use. A large majority of the older shops are so arranged as to prevent the use of overhead traveling cranes, but the introduction of electric motors has made it possible where the change can be afforded for some of our railway shops to erect them. Where this cannot be done the work can be greatly facilitated by putting up at needed points the best forms of chain hoists in connection with pneumatic lifts, etc., as in the case of other improvements mentioned. A visit to some of the shops where this has been done will assist greatly in giving an idea of what can be done to do away with the old plans of "main strength and awkwardness" so prevalent in many shops that have lots of work to do; they are the greatest time and labor savers that we have, and their importance cannot be over-estimated.

It has been suggested to your committee that a more proper subject for consideration in this line would have been "the advantages of modern tools and modern methods in railroad shops," for the reason that there is opportunity for a larger proportionate saving in the ordinary well equipped plant by changes in methods than by the adoption of the latest tool which may be on the market.

THE DIESEL HEAT MOTOR AT THE MUNICH EXPOSITION.

Consul General Frank H. Mason, writing from Frankfort, Germany, to the State Department under date of June 25, describes the status of the Diesel motor in Germany. This motor was illustrated and described on page 265 of our August issue.

In a previous report by Mr. Mason, describing briefly the new calorific motor invented by M. Rudolf Diesel, it was stated that at the machinery exposition to be held at Munich this summer a collective exhibit would be made by the several firms and companies in Germany which have begun the manufacture of Diesel motors of different types for practical use.

The exposition was opened early in the present month and will continue until October. The display of Diesel motors occupies a special building, and, in view of the originality and vast economic importance of the new engine, is recognized as the most interesting feature of the exhibition. The interest manifested in this invention by American engineers and machinists has been so general and insistent that a brief account of what can be seen at Munich during the coming three months may be of timely import, although it is generally known that all patented rights for the construction and use of the Diesel motor in the United States have been acquired by an American company whose main office is at No. 11 Broadway, New York.

The collective exhibit at Munich is made by the Augsburg Machine Company, where the invention of Mr. Diesel was first built and tested in practical form, Messrs. Fred Krupp, in Essen, the Machinery Construction Company of Nuremberg, and the well-known Otto Gas Motor Manufacturing Company of Deutz-Cologne—four of the most important and powerful manufacturing firms in Germany, whose names form a sufficient guaranty of the industrial value of the new engine. The Diesel motors on exhibition are five in number, and are described in the official catalogue as follows:

1. By the Augsburg Machinery Company: Single cylinder, 30 horse-power motor, for petroleum fuel; drives a rotary pump that lifts 389 gallons of water per minute to a height of 196.7 feet.
2. By Fred Krupp of Essen: Single-cylinder, 33 horse-power engine, which drives a high-pressure, centrifugal pump that draws up from the River Iser a stream of water that is projected through a 2-inch nozzle at 45 degrees elevation to a distance of 230 feet into the river.
3. By the Machinery Construction Company of Nuremberg: A single-cylinder, 20 horse-power motor, which, at a speed of 180 revolutions per minute, is used for purposes of test and demonstration.
4. By the same company as above: One double-cylindrical, 40 horse-power motor, coupled directly to a Schuckert dynamo, and at 180 revolutions per minute generates current for lighting the pavilion and driving a fast rotary printing press and several machine tools which are installed in the same building.
5. By the Otto Gas Motor Manufacturing Company of Deutz-Cologne: One single-cylinder motor of 20 horse-power, which propels a Linde condensing machine for the production of liquefied air.

HEAVY CHIPPING WITH A PNEUMATIC HAMMER.

The accompanying engraving shows an enlarged view of the piece of boiler plate which formed part of the exhibit of the Chicago Pneumatic Tool Company at the Saratoga convention mentioned on page 238 of our July issue. This steel boiler plate is 5/8-in. thick and not 7-16-in., as previously stated. The

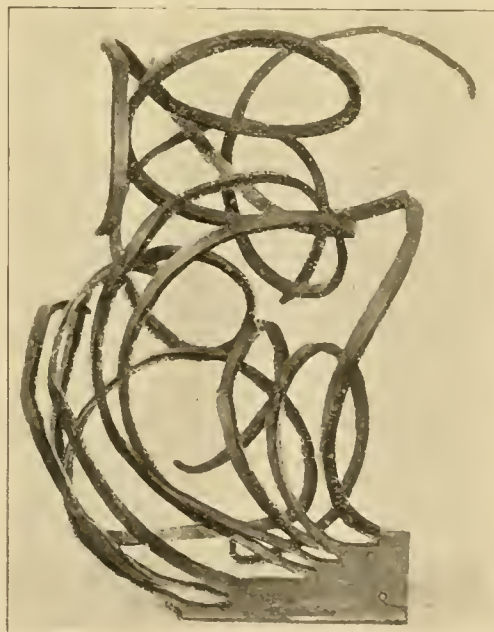

Example of Work Done by a Pneumatic Hammer.

work was done with a No. 1 Boyer pneumatic hammer, and the chips are over 5 ft. long. The cutting was done at a rate of about 15 ins. per minute and without vibration or injury to the hand of the operator.

ASSOCIATION OF SUPERINTENDENTS OF BRIDGES AND BUILDINGS.

The Association of Railway Superintendents of Bridges and Buildings, through its President, Mr. Walter G. Berg, directs our attention to a circular relating to the eligibility of railroad men for membership in the Association. The requirements are expressed in a resolution passed at the convention held in Denver last year, and it is desired that the benefits of membership should be taken advantage of by as many as possible among the men who are eligible. The resolution was as follows:

"Resolved, That, in the opinion of the Executive Committee, the following clause of the constitution referring to the eligibility of an applicant for membership, namely: 'Any person at the head of a bridge and building department on any railroad, or a division or sub-division, and to include assistant superintendent and general foreman of any railroad, shall be eligible to membership.' should, in accordance with the action of the Association in the past, be construed on the basis that the applicant must be in the employ of a railroad company, either as a superior officer with general control over questions affecting the bridge and building department, or as a subordinate official having actual responsible charge of work connected with the construction or maintenance of railroad bridges or buildings, independent of the actual title, whether as superintendent, supervisor, engineer, general foreman, general inspector, master of road, master carpenter, etc., but not to include persons only in sub-charge of individual jobs or special classes of work, such as gang-foremen, inspectors, clerks, draftsmen, etc."

The Association will hold its eighth annual convention at Richmond, Va., Oct. 18 to 20, 1898, the programme for which includes a number of interesting subjects of reports of investigation.

CYLINDER FASTENINGS FOR LOCOMOTIVES.

On page 250 of our July issue an abstract of the report of a committee of the Master Mechanics' Association on "Best Form of Fastenings for Locomotive Cylinders" was printed. The Chairman of the committee, Mr. J. E. Sague, was unable to assist in the preparation of the report, and submitted additional discussion as follows:

The strains on cylinder fastenings, as well as upon other parts of locomotives, have been much increased within the last few years in the notable rise in boiler pressures, which has resulted in a more marked increase in locomotive power than is indicated by comparison of cylinder sizes only. Thus many recent designs of locomotives have 20 by 26 cylinders with 200 pounds boiler pressure, or the equivalent of a 23 by 26 cylinder with 150 pounds of steam. Modern systems of tonnage rating have also added to strains imposed upon locomotives, making it certain that they will exert their full power more constantly than ever before.

A decided limit, however, is imposed upon the weight of material to be used in cylinders and frames by the demand for high boiler power, and it is very common for builders to have specifications submitted to them calling for greater boiler capacity than can be obtained within the permitted limits of weight, after all possible has been done to lighten other parts. It will be admitted that in order to obtain the best road locomotives, either passenger or freight, the boiler must be made as large as possible, and with this in view the weight of all other parts must be kept as low as design will permit, assuming reasonably good handling and attention to running repairs, and this condition should be kept carefully in mind in considering the design of cylinders, frames and cylinder fastenings.

The principal strains to which cylinder fastenings are subjected are thoroughly discussed in the committee's report. The effects of these strains on cylinder fastenings, however, are believed to be greatly modified by the use or absence of a foot plate. A foot plate well bolted and keyed holds the frames rigidly in line with each other lengthwise and thus reduces greatly the racking strains upon the cylinders due to the action of the steam. Consolidation and other types of locomotives which have no foot plate, therefore, require exceptional strength in the cylinder fastenings, unless the equivalent of a foot plate is provided.

In recommending designs of cylinder fastenings distinction should be made between passenger and freight locomotives, even where the cylinder power is the same. Passenger locomotives exert their full tractive power only at starting and the cylinder fastenings are not exposed to as severe continuous strains as those of freight engines. Passenger locomotives, as a rule, also receive better care. Large boiler power is of such supreme importance in passenger locomotives that the weight of all other parts must be reduced as much as possible. These considerations, it is believed, justify the use of lighter cylinder fastenings than would be good practice for freight. This is especially true for eight wheel passenger locomotives, whose truck and driving wheel weights are apt to be close to the track limit.

Referring to the connection of cylinders to boiler, the replies indicate but little trouble with this fastening. Several recommend double bolting either front or back or on the side flanges. Double bolting front and back or on the side is extensively used on heavy locomotives and in a few cases cylinders are double bolted all around. Double bolting front and back has the advantage of lengthening the cylinder fit on the smoke arch, and enables the maximum number of bolts to be placed through the smoke box rings, but for equal weight of metal in the flanges the double side bolting enables more bolts to be used.

Regarding the connection of cylinders to frames and the design of the frames at the cylinders, practice varies greatly and it is difficult to lay down any rules which will be of general value; especially is this true regarding the choice between single and double bar front frames. Double front frames give a more secure cylinder fastening than can be obtained with single rail frames. They make an especially good design for consolidation, mogul and other locomotives in which the drivers are close to the cylinders, and are being widely adopted for heavy ten and twelve wheel locomotives. Considering the strength of the frames only, the design of double front frames involves the use of more weight for equal strength than with single, and this is an important reason for the continued use of single front frames on so many recent eight-wheel passenger locomotives. For this type of locomotive the great length of single front rail permits some flexibility, and there is less liability of the strains being concentrated at breaking point than if the rails were short. With the single front rail bolted on a line with the centers of the cylinders the strains due to the steam pressure are taken directly. With double front frames these strains are exerted mostly upon the bottom rail, as this rail is necessarily much nearer to the center of the cylinder than the upper one. The bottom rail, therefore, requires nearly as much section as if a single rail only were used. The breakages of upper rails, however, show that important strains are transmitted through them, and these are probably quite complex. Very great strains are brought on the upper rail by the expansion of the boiler, especially when the expansion pads are binding. Any yielding or springing of the bottom rail will also throw disproportionate strains on the upper one. The experience of members indicates that to avoid trouble with double front rails it is necessary to design them so as to be as free from bending strains as possible and to connect them so that they will resist the strains almost as if made of one piece; otherwise the rails may yield and break in sections. The indications point to bending strains localized where the working and breakage are noticed and it is also believed that this working was largely caused by the sticking of the expansion pads on the sides and back of firebox. To resist these strains more successfully filling blocks are put in and are found to meet the difficulties successfully. For ten and twelve wheel locomotives which involve greater length between the forward pedestal and the cylinders the filling pieces are thought to be even more necessary than in mogul and consolidation locomotives, and it is believed that double front frames not provided with such bracing will give more trouble than single bar frames. Mr. Middleton of the Baltimore & Ohio advises single front frames on eight-wheel locomotives and on ten wheelers having a considerable distance between the front pedestal and the cylinders. Mr. Vaucain writes: "We recommend single front rails for frames on engines having a four-wheel truck ahead, and double frames for two-wheel trucks. In any case where the single front frame is radically out of line with the draw head double frames should be used."

The writer believes that the following is good practice: Double rail front frames should be used on all consolidation and mogul locomotives, and on heavy ten and twelve-wheel freight locomotives, especially where built for mountain service. Single front frames should be used on eight-wheel passenger locomotives, as they have been found amply strong for this class of engine with good design of maintenance, and because the use of double frames would necessitate increased driver and truck weights for a given boiler capacity. The same applies to fast passenger ten wheelers where great boiler power is desired and where close limits of weight are to be conformed to. For large ten-wheel passenger locomotives to be used on mountain work or in exceptionally severe service, the better cylinder fastening obtained by the double front frame makes its use advisable. Filling blocks should be used for double rail frames, as before indicated, and the splices between the front and main frames should, as far as possible, be designed to avoid bending strains.

To prevent cylinder saddles breaking, due to the expansion of boiler, some members recommend outside vertical ribs. These, with the lower cross ribs shown and with the bolts through the outside lugs which the ribs form at the frame connections, are believed to make a very secure job.

Regarding the advisability of using cross ties front and back of cylinders or long transverse bolts through the cylinder saddles, there has been a strong expression of opinion from members in favor of using one or the other of these devices. For double front rails, cross ties lipped over the top rail and shrunk on front and back of the cylinders assist in tying the frames to the cylinders and also greatly help the connections between the cylinder saddles. The action of the steam in the cylinders tends to spring the frames otherwise and separate the cylinders where bolted together, thus practically bringing a cross bending strain upon the saddles, and the cross ties are very effective in resisting these strains. Cast iron, although very strong in compression, is deficient in tensile and transverse strength, and it

is therefore believed that wrought iron cross ties serve a better purpose in reinforcing the cylinder saddles than would be obtained by increasing the saddle length, and with much less increase of weight. Where cross ties are used suitable flanges, of course, should be provided on the cylinders to resist the pull of the cross ties. Inside lips on the cross ties are unnecessary, and if well fitted prevent the cross ties being shrunk on after the frames are bolted in place. The advantage of cross ties is shown from the fact that they are used successfully to hold cylinder saddles after cracking, and therefore cannot fail to assist in preventing cracking. Long transverse bolts through the cylinder saddles serve the same purpose in holding the saddle together as cross ties, and have been found very useful on many roads, but they are not thought to be as effective as cross ties, as they do not assist in holding the frames to cylinders and cannot be spaced as advantageously to resist bending strains in the saddles. They are useful, however, for cylinders having single front frame connections. Where used they should be placed as low down in the saddle and as near the back and front as possible.

BOOKS AND PAMPHLETS.

"Railway Construction," By William Hemingway Mills, M. Inst. C. E., Past President of the Institution of Civil Engineers of Ireland and Engineer in Chief of the Great Northern Railway of Ireland, New York, London and Bombay: Longmans, Green & Co., 91 Fifth avenue, New York, 1898. Large octavo, 366 pages; many illustrations and index. Price \$5.

This is an excellent book on English railway construction, giving in considerable detail the methods of conducting work in construction and maintenance of stations, bridges, foundations, track, culverts, walls, sidings, switches, interlocking, signal and brake apparatus and some general treatment of locomotives. The work opens with the location and government regulations, followed by chapters on works of construction and permanent way, stations and other buildings. Sidings, turntables, water tanks and water columns are treated in turn, after which a whole chapter is given to weights and types of locomotives. Signals, interlocking, telegraph and staff systems occupy another chapter, and the closing pages treat of railways of different ranks, progressive improvements, growing tendency for increased speeds with corresponding increase in weight of permanent way and rolling stock, the last subject treated being electricity as a motive power.

What may be termed the massive solidity and conservatism of the book is best expressed by quoting its closing paragraph: "Strength and efficiency are the leading points which must be always kept in view, and the engineer must never forget that he is solely responsible for the safety of the line and works, and that of the public passing over the same." Instead of presenting details of construction Mr. Mills attends chiefly to general principles and leaves the application of these to those who educate and train engineers for their work. He shows many examples from practice, and these have evidently been selected with great care in order to record only what is trustworthy. He also leaves matters of cost to others, but it is clear that he does not always consider the matter of cost as sufficiently important. We believe that American practice shows examples of equally good methods that are sometimes much less costly. He does not like our flanged rails, preferring the "bull-head" section, saying of the flange rail: "Having fewer parts, it makes a cheaper road than the bull-head rail, but is not considered so strong or suitable for heavy and fast traffic."

When he writes of brakes for freight service he is amusing; for instance, he says on page 46: "Every goods wagon should be fitted with a brake, and it would be of immense value if that brake could in all cases be applied and controlled when the train is in motion." This is followed by a detailed description of an American freight car hand brake, and herein is a commentary upon English freight brakes, because of our ordinary hand brakes being considered interesting enough to take the space of a book that is intended to be up to date. A primitive braking appliance, the "sprag," is described. It is a wooden bar passed between the wheel spokes to skid the wheels and assist in safely passing heavy downgrades. We would suggest that English railroad men order a car load or so of Westinghouse catalogues. The work under consideration is certainly weak in regard to brakes, but throughout we see indications of a desire to benefit from foreign practice when it appears to be available. For example, American "bogie" engine trucks are illustrated and the au-

thor says: "Its recommendations are its simplicity, its efficiency and its accessibility for inspection and lubrication." Mr. Mills appears to be afraid of heavy locomotives, thinking that they are not steady and safe on the rails. He means to be always on the safe side of every question. He approves the ten-wheel type as used in the United States.

The strongest feature of the book is in presenting a large number of examples of successful practice. It will have the greatest value in countries where English practice is followed, and it records much that American engineers ought to know about. As presenting a general view of railway construction, from the point of view mentioned it is successful.

The engravings are good, the letterpress excellent. It is printed on unusually good paper and the binding is serviceable. It has an index, but we would like to see more cross references.

"The Indicator Handbook." Part I. The Construction and Application of the Indicator. By C. N. Pickworth, Editor the "Mechanical World." 126 pp., 81 illustrations. D. Van Nostrand Company, 23 Murray street, New York. Price, \$1.50.

This is a valuable little book. It treats of the indicator, its use and its errors, while Part II. will treat of indicator diagrams and their analysis. There is much that is new in Part I., the illustrated descriptions of the Wayne and the Simplex instruments having their springs outside of the instrument, and away from the influence of the steam, being specially noteworthy. These indicators are described here for the first time in a work of this kind. The Wayne indicator uses a rotary instead of reciprocating motion for the piston and the card is held on a curved shield, the pencil movement being radial to the paper. The descriptions of these and the more common instruments are well written, and the author takes pains to bring out the characteristic features of each type and each design. All the reliable instruments are included. Indicator attachments and reducing motions are given a good share of space and the errors of the indicator itself and of the reducing motions are very fully treated. The most common rigs are shown in small scale drawings, and below them are scales which show the errors very clearly. Among the errors of attachment are those due to long pipes and long cord connections. Methods of testing are described. The book will be useful to engineers, even those who have had a great deal of experience with indicators, and to students it will be valuable as a text book. It is up to date and its purpose is so well carried out that we look forward to the appearance of Part II. with considerable interest. Part I. is complete in itself, it is well written, printed and illustrated, and is of a convenient size, 5 by 7 1/4 in. The author shows that he thoroughly understands his subject.

"Universal Directory of Railway Officials, 1898." Compiled from official sources by S. Richardson Blundstone, editor of "The Railway Engineer"; price 10 shillings. The Directory Publishing Co., Lim., 8 Catherine St., Strand, W. C., London. Representative for the United States: E. A. Simmons, 717 Chauncey St., Brooklyn, N. Y., 1898; pp. 475; boards.

We look upon this publication as a necessity in any office where there is occasion to look up the names and addresses and amount of equipment of foreign railroads. The revision this year has been carefully made, as usual, and brought up to date as nearly as possible in a work of this character. The new lines added are in Denmark, China, Nicaragua and Sudan, and also light railways in the European countries. The preface states that, with exception of the African German colonies, information respecting every railway in Africa is now included in the directory. Twenty-five pages have been added to the directory section and the personal index has been made proportionately larger.

"Administration Report on the Railways in India" for 1897-1898, by A. Brereton, Esq., Director of Railway Traffic and Statistics, Part I., Simla, 1898, Government Printing Office.

"Some Statistics of Engineering Education," by Dr. M. E. Wadsworth, President of the Michigan College of Mines, Houghton, Michigan. A reprint of a paper read before the Lake Superior meeting of the American Institute of Mining Engineers.

"The Elective System in Engineering Colleges," by M. E. Wadsworth, Ph. D., Director of the Michigan Mining School, Houghton, Michigan. A paper reprinted from the proceedings of the Society for the Promotion of Engineering Education, Buffalo meeting, 1896.

The Russell Snow Plows and Flangers, 1898.—The Russell Snow Plow Co., Mr. J. W. Russell, Manager, Tremont Building, Boston, Mass., has issued a new catalogue illustrating and describing their plows. The pamphlet gives 28 pages of information concerning the construction of the plows for different classes of work, and also giving the weight, dimensions and other information necessary for intelligent ordering of this equipment. The Russell snow plow has been developed by long experience which has led to successful use at speeds as high as 35 miles per hour into side hill drifts and diagonal banks of snow, which in some places attained a depth of 14 ft. in curved cuts, and even 50 miles per hour under other conditions. A longitudinal section of one of the large plows shows its construction to be such that the frame transmits the force from the engine to the front of the plow, so as to keep it upon the track, and those who are investigating the subject of snow plows should examine the construction of this type. The trucks under the front ends are exceedingly heavy and strong. They are of the diamond frame type, with four frames and eight journal bearings for each truck, the axles having bearings both inside and outside of the wheels. The plows are of different sizes and forms and are adapted for fast trains on single track, for right or left hand running on double track and for combined shoveling and flanging. The wing elevator plow is designed to leave a clear road over 16 feet in width, which is accomplished by the use of wings pivoted to each side of the car and one of these may be omitted from the plow if desired. The elevators on the wings are inclined planes which cut under the snow, and lift and throw it from 30 to 60 feet away, according to the speed of the train. On railroads with two or more parallel tracks these wings lift and throw the snow clear of the right of way and clean it out from between the tracks. A specialty is made of flanges, which are so constructed as to be strong and durable and at the same time easily operated by hand or compressed air. The pamphlet contains a record of snow plows from this company during the winter of 1896 and 1897 on the Northern Pacific Railway in North and South Dakota, that winter being an exceedingly severe one as regards snow blockade. A plow was used in hard, frozen snow from 9 to 12 ft. in depth over both rails, and in temperatures as low as 18 degrees below zero. The statement says: "On March 5 was the most severe storm, a blizzard, continuing for over 24 hours. The plow was run from 25 to 45 miles per hour, with 2, 3 and one 4 mogul engines with 18 by 24 inch cylinders behind it. The miles run were as follows: On main line 1,042, on branch line 531, a total of 1,573 miles. In spite of the fact that unusually hard work was done, part of which was upon branch lines with a poor road bed, the plow never left the rails, nor was it broken or disabled; neither was there any accident to the snow plow or its train. An equally satisfactory record is shown for work on the New York Central & Hudson River Railroad.

"Pop" Safety Valves.—The Consolidated Safety Valve Company, 111 Liberty street, New York, have just issued a new catalogue containing illustrated descriptions of the various styles of "Consolidated Pop Safety Valves," manufactured by them, including several new styles not previously illustrated. The importance of using only the best safety valves is first pointed out and several styles of nickel-seated valves are illustrated, after which three pages are filled with testimonial letters from such concerns as the Babcock & Wilcox Company, the Stirling Company, the Abendroth & Root Manufacturing Company, the Heine Safety Boiler Company and the National Water Tube Boiler Company, all of whom are using these valves on their water tube boilers. In a letter from the concern first mentioned it is stated that: "Out of 3,737 safety valves of your make which we have put out there has not yet been a single unsatisfactory valve." Over 200,000 pop safety valves have been sold by this firm, and the catalogue states that none of them, to their knowledge, have ever failed to work with satisfaction. Five pages are devoted to valves for marine work, and letters are printed from Wm. Cramp & Sons, the Newport News Shipbuilding & Dry Dock Company and the Union Iron Works, the three largest ship-building firms in the country, stating their satisfactory experience with these valves. Among the remaining illustrations are a number from locomotive work, both pop and relief valves, the company having been manufacturing these valves since 1866. Among the valves for locomotive use is the Blackall relief valve for attachment to locomotive dry pipes,

anywhere between the throttle and the steam chest, for the relief of pressure due to reversing the engine while moving forward. On page 44 is a list of about 130 railroads using these goods. The pamphlet is standard size; it is well printed and illustrated and serves its purpose well. Copies will be mailed to those who apply to the above address.

"Pressed Steel in Car Construction."—One of the handsomest catalogues that ever came into this office has just been received from the Schoen Pressed Steel Company of Pittsburgh, Pa. It is 9 by 12 inches in size and is beautifully illustrated with half-tone engravings from photographs and drawings made specially for the purpose. The frontispiece is a page engraving of the works of the company at Pittsburgh, which is followed by an interior view of one of the car erecting shops and one of the exhibit of the company at the World's Fair in Chicago. The other engravings show in succession the truck and body holsters, the pedestal truck complete, the diamond-frame truck, underframing for flat cars, flat car complete, gondola car, a self-clearing hopper car of 100,000 pounds capacity, a steel car of 80,000 pounds capacity for the P. & L. E. R. R., a twin hopper coal car of 110,000 pounds capacity for the P. R. R., a self-clearing 100,000-pound ore car for the L. S. & I. Ry. and two views of a self-clearing coke car for the Frick Coke Company, all of which are in pressed steel. The last engraving in the book is from an instantaneous photograph showing a train of 35 Schoen pressed steel cars in motion, each car containing a load of 108,000 pounds of ore. The text accompanying the engravings presents in concise language the advantages of pressed steel in car construction. The book is sure to be read and prized by those for whose use it was intended, and it forces the conclusion stated at the beginning of the work that "An all-steel car is not a theory, but an accomplished fact."

"Electricity for Machine Driving." Westinghouse Electric & Manufacturing Company, Pittsburg, Pa.

This is a 24-page pamphlet which points out in a brief, concise manner a few of the advantages to be secured by the substitution of electric distribution of power for the common method, involving long lines of shafting and connecting belts. The methods described lead to great reductions of operating expenses, and the pamphlet is recommended to manufacturers and others who have charge of power transmission plants. It is especially commended to those who are operating plants which, starting from one that is small and well arranged, have grown with the increase in business until they are scattered over large areas, making it necessary to divide the power into a large number of uneconomical units. This applies to many railroad shop plants as well as to manufacturing establishments. The pamphlet is illustrated with handsome half-tone engravings upon the left hand-pages, and opposite them the advantages of electric transmission are presented in concise paragraphs. Its attractiveness will draw attention at once, and the pamphlet will be likely to find a place in files for future reference, if not for immediate use. The style of the author is flowery, but the work is well done.

"Baldwin Locomotive Works. Record of Recent Construction." Pamphlet Nos. 6 and 7, July, 1898.

These pamphlets in the series now regularly published by the Baldwin Locomotive Works illustrate a variety of locomotives of standard and narrow gauges, for domestic and foreign roads, and with steam and electricity for motive powers. The dimensions and characteristics of each design are shown, which makes the record a valuable one for reference and for study of the tendencies in locomotive construction from these works. No. 7 is devoted entirely to narrow-gauge engines, the narrowest being 1 ft. 11½ in.

The Chicago Pneumatic Tool Company has found the demand for information concerning its pneumatic tools so great as to necessitate what are termed "special editions" in the form of additions to its catalogues. The latest of these are devoted to riveters, hammers and drills, and to wood boring machines, breast drills and painting machines. They are well printed and well illustrated, and show the machines while actually at work.

"Snow Sweepers, Snow Plows, Track Scrapers." The J. G. Brill Co., Philadelphia, have distributed a 16-page illustrated pamphlet dated Aug. 1, 1898, describing their designs of snow

removers for street railways. Preparations for winter are urged, and the fact of the great loss on account of a single day's snow blockade due to lack of efficient equipment of this kind is pointed out. The illustrations and text give the information necessary to order the snow sweepers, snow plows, nose plows for single track, the Littell track scraper and the combination snow plow and construction car. The usefulness of this last mentioned car is increased by its adaptability to construction purposes when not needed in snow service. These builders have made a specialty of this work, and are prepared to furnish equipment that is of great strength and power.

"Routes and Rates for Summer Tours Via New York Central & Hudson River Railroad, Rome, Watertown & Ogdensburg Division."

This is an octavo pamphlet of 228 pages and 150 excellent engravings of noted places and summer resorts. It gives a list of 800 hotels and routes and rates for 600 combination excursion tickets for Niagara Falls, Thousand Island resorts, Saguenay River, White Mountains, Green Mountains, Adirondack Mountains, Halifax, Portland, Old Orchard Beach, and seacoast resorts of Maine, St. John, N. B., St. Andrews, N. B., and the Maritime Provinces. It contains seven excellent maps printed in colors. Those who contemplate visiting these places and those who do not and would like to read about them will do well to send to Mr. Geo. H. Daniels, General Passenger Agent, for a copy, inclosing 10 cents for postage.

EQUIPMENT AND MANUFACTURING NOTES.

Bement, Miles & Co. are building several large machine tools for export. Among them are eight gun lathes, which are to go to England and Russia.

The Richmond Locomotive & Machine Works have just closed a contract with the Plant System for 12 locomotives, and with the Georgia & Alabama for 4 locomotives.

The new coaches for the Chicago Great Western's new fast train have been painted a dark green, which suggests that the road is getting tired of brick red as a color for its passenger equipment.

The Safety Car Heating & Lighting Company has contracted with the New York Central & Hudson River R. R. for Pintsch gas lighting equipment for 250 additional coaches, which will bring the total number of Pintsch light coaches on that road up to 807.

The Westinghouse Machine Company and the Westinghouse Electric & Manufacturing Company have a combination order for a complete steam plant for Santiago, Cuba. It consists of a 100-H. P. Westinghouse engine and generator, with boiler, feed pump and piping complete.

The Russell Snow Plow Company has recently received orders for a Russell Wing Elevator Snow Plow, size No. 2, from each of the following railroads: The Michigan Central, the Intercolonial Railway of Canada and the Flint & Pere Marquette. The plow for this latter road is to be equipped with the Russell air flanger.

The Brooks Locomotive Works completed their 3,000th locomotive July 23 and held a celebration in honor of the event. The engine was another of the immense mastodons for the Great Northern. The works were founded in 1869. The 1,000th locomotive was completed in 1884 and the 2,000th in 1891.

Mr. G. Fred Collins, who, for a number of years has been connected with Valentine & Company, has, in addition to continuing with them, been appointed Eastern representative of the Ewald Iron Company, St. Louis, manufacturers of Tennessee Charcoal Bloom Stay Bolt Iron, with headquarters at 57 Broadway, New York City.

Bement, Miles & Co. inform us that Mr. Charles E. Billin has severed his connection with the concern as representative in Chicago. We understand that Mr. Billin will give his attention to business under his own name, and that the firm of Bement, Miles & Co. should be addressed as before, at 1534 Marquette Building, Chicago.

The Chicago Pneumatic Tool Company, Monadnock Building, Chicago, received orders for 78 pneumatic machines in a single day, July 25. Such an order received during the summer season is gratifying, as an example of the increasing popularity of these tools. Four of these are for the Imperial Chinese Railway, and the distribution among the different devices was as follows: 44 pneumatic hammers, 8 pneumatic holders on, 6 riveting machines, 4 Boyer piston air drills, 12 breast drills for wood boring, 2 air hoists, 2 flue welders.

The Sargent Company's open hearth steel plant has been running for the past two months at its fullest capacity on several large contracts, among which may be mentioned the castings for 10-in. gun carriages for the United States Government. The company has been very successful in this class of work, readily meeting the physical tests prescribed by the Government, as well as the prompt delivery which is usually demanded. The good record that they have been making is taken as an indication that they will obtain their full quota of this class of work in the awarding of future contracts.

Baltimore & Ohio engine No. 99, which has just been laid aside at Grafton, W. Va., and will be consigned to the scrap pile, has quite a history. It is one of the Ross Wmams camel engines and was built in 1851. There are only four of this class now remaining. During the late war this engine was one of several captured at Martinsburg by the Confederates, and hauled across the country by pike to Staunton, Va., under direction of Col. Thomas R. Sharp. President John W. Garrett, after the war was over, hunted up Col. Sharp and appointed him Master of Transportation, in recognition of the ability displayed in that unparalleled achievement.

Within the past 60 days the receivers of the Baltimore & Ohio Railroad have ordered nearly 6,000 new freight cars, of which the Pullman Company is building 1,000 box and 1,000 drop-end gondolas; the Michigan Peninsular 3,000 box cars, and the South Baltimore Car Works 200 box cars, 500 hopper coal cars and 15 four wheel cabooses, making a total of 22,735 freight cars ordered in less than two years. These cars are all of modern construction, are fully equipped with air brakes and automatic couplers and average 60,000 pounds capacity. It is estimated that fully 85 per cent. of the B. & O. freight cars have air brakes and automatic couplers in accordance with the Interstate Commerce Law.

American street cars are used in Manila, and when Admiral Dewey and General Merritt and their men have occasion to ride in that city they will feel "at home." The entire equipment of the "Tranvias de Filipinas" was furnished by Messrs. J. G. Brill Co. of Philadelphia. These cars number about 25, and seat 20 passengers. They weigh less than 2,700 pounds each, which is very light considering their carrying capacity. They are hauled by horses not much larger than Newfoundland dogs. The gage of the road is 3 feet 6 inches, the width of the cars being 5 feet 6 inches and the length 17 feet 6 inches. The closed cars have 2¼-inch steel axles, 2½-inch journals.

Messrs. Neilson, Reid & Company of the Hyde Park Locomotive Works, Glasgow, report to "The Railway World" that they have on hand a large amount of work for India, aggregating 137 locomotives. These include 90 passenger engines for the East India Railway, 34 for the Nizam State Railway, 10 for the Indian State Railway and 2 for the Calcutta Port Commissioners. Messrs. Neilson, Reid & Company have hitherto had facilities for the production of about 400 locomotives per annum, but we understand that the works are to be greatly enlarged and that the capacity will be nearly doubled. It is satisfactory to note this evidence of enterprise on the part of one of our best-known locomotive makers. Competition from American manufacturers is constantly becoming keener, and during the past year British builders have had several warnings as to what may be expected in the near future if some special efforts are not made to retain the Eastern trade. Quite recently orders for 77 locomotives for China and 17 for Russia were given to American builders, one of the reasons being that quicker delivery could be obtained from them than from British builders.

The fact that the gross earnings of the Baltimore & Ohio Railroad from the operations of the road for the fiscal year ending June 30, 1898, reached the sum of \$27,642,432, an increase of \$2,060,310 over the similar period of 1897, has created considerable favorable comment in financial circles. The receivers, after they were appointed and had examined the situation carefully, were confident that if their policy was carried out the earnings of the railroad would be very greatly augmented, and as is well known, they began a series of improvements that, while not yet completed, have progressed sufficiently to demonstrate beyond question that the Baltimore & Ohio Railroad has an earning capacity that will place it in the ranks of the profitable railroads in the country in a few years. The two million dollars' increase in gross was made only with an increase of \$281,391 in expenses, giving a net increase of \$1,778,919, the approximate net earnings from the roads alone for the year being \$7,348,947, over \$800,000 in excess of what the fixed charges will be under the plan of reorganization. In addition to these earnings there is a miscellaneous net income from various sources of about \$900,000.

OUR DIRECTORY

OF OFFICIAL CHANGES IN AUGUST.

Atchison, Topeka & Santa Fe.—The position of Division Master Mechanic at Topeka, formerly held by Mr. George W. Smith, now Superintendent of Machinery of the Santa Fe Pacific, has been abolished.

Atlantic Coast Line.—Mr. G. G. Gadsden of Charleston, S. C., has been elected President.

Cornwall.—Mr. A. G. Machesney has been appointed Master Mechanic, with headquarters at Cornwall, Pa. He succeeds Mr. C. J. Herman.

Central of New Jersey.—Mr. William L. Hoeffcker has resigned as Division Master Mechanic at Elizabethport, N. J.

Chicago & Northwestern.—Mr. M. L. Sykes is Vice-President and Secretary.

Colorado & Northwestern.—At the annual meeting of stockholders held July 19 at Boulder, Colo., Mr. W. C. Culbertson, Girard, Pa., was elected President, vice E. C. Thompson, Meadville, Pa.

Chesapeake & Ohio.—It has been decided to discontinue the office of Chief Engineer, held by H. Frasier, who resigned recently. The duties will be performed by Engineers Maintenance of Way on each of the grand divisions.

Chicago, Fort Madison & Des Moines.—Mr. E. F. Potter, Vice-President and General Manager, was on July 27 appointed Receiver.

Chicago, Rock Island & Pacific.—Mr. A. L. Studer has been appointed Master Mechanic of the Illinois Division.

Chicago & Erie.—Mr. William Kells has been appointed Master Mechanic, with headquarters at Huntington, Ind., in place of Mr. J. Hawthorne, resigned.

Chicago Great Western.—Mr. A. M. Holcomb has been appointed Assistant Chief Engineer, with headquarters at St. Paul, Minn., in place of Mr. H. A. Stahl, resigned.

Delaware & Hudson Canal Co.—Mr. C. E. Rettew, Master Mechanic of the Pennsylvania Division, has resigned. He is succeeded by Mr. W. R. Johnson, heretofore Foreman of the Locomotive shops at Carbondale, Pa. Mr. Rettew succeeded Mr. S. H. Dotterer as Master Mechanic twelve years ago.

Erie & Central.—Mr. Charles O. Scull has been chosen President. He was formerly General Passenger Agent of the Baltimore & Ohio.

Erie.—Mr. Frank Johnson has been appointed Master Mechanic of the Mahoning Division, with headquarters at Youngstown, Ohio.

Fulton County Narrow Gauge.—Mr. J. D. Thayer, Vice-President and Secretary of this company, died on June 21, 1898, at Burlington, Ia. It is also announced that on June 24, 1898, Mr. J. D. Temple, late Auditor of this company, died at Des Moines, Ia.

Grand Trunk.—Mr. John T. Gill has been appointed Air Brake Instructor, with headquarters at Montreal, Can.

Georgia Southern & Florida.—Mr. O. M. Grady, formerly Roadmaster, has been appointed General Superintendent, succeeding the late Jeff. Lane, with headquarters at Macon, Ga. R. D. Grey, formerly Chief Clerk to Mr. Lane, has been appointed Purchasing Agent, the duties of which office were formerly discharged by Mr. Lane.

Georgia Pine.—Mr. K. G. Stone, General Freight and Passenger Agent of the Macon & Birmingham, has been appointed General Manager of this road. He succeeds Mr. R. B. Coleman, with headquarters at Bainbridge, Ga.

Hannibal & St. Joseph.—Mr. W. W. Lowell has been appointed Division Master Mechanic, with headquarters at Brookfield, Mo.

Indiana, Illinois & Iowa.—Mr. F. C. Raff has been appointed General Superintendent. He was formerly Superintendent.

Interoceanic.—Mr. William Rees has been appointed General Master Mechanic, with headquarters at Juebla, Mex.

Kinderhook & Hudson.—Mr. James Purcell has been elected President.

Louisiana & Northwest.—Mr. F. O. Emerson has been appointed Master Mechanic, with headquarters at Gibsland, La.

Lehigh Valley.—Mr. J. Hawthorne has been appointed Master Mechanic of the Pennsylvania & New York Division, with headquarters at Sayre, Pa., vice Mr. J. N. Weaver, resigned.

Michigan Central.—The title of Mr. H. B. Ledyard, President and General Manager, has been changed to President; the title of General Manager having been dropped.

Mobile & Birmingham.—Mr. T. E. Hartwell, formerly General Foreman, has been appointed Master Mechanic, succeeding J. J. Thomas, Jr., who resigned to accept the position of Master Mechanic of the Mobile & Ohio at Tuscaloosa, Ala.

Maine Central.—Mr. Charles D. Barrows has been appointed Purchasing Agent. He succeeds Mr. Arthur S. Bosworth.

Michoacan & Pacific.—Mr. E. W. Knapp has been appointed Master Mechanic, with headquarters at Zitacuaro, Mex., vice Mr. W. H. Rice, resigned.

New York, New Haven & Hartford.—Mr. W. E. Chamberlain has been appointed General Manager. He was formerly General Superintendent of the Old Colony System.

Northern Pacific.—The following changes have been made on this road: Mr. William Clarkson, Master Mechanic at Missoula, Mont., has been transferred to Livingston, Mont., vice Mr. Brown; Mr. E. P. Barnes, General Foreman at Brainerd, Minn., succeeds Mr. Clarkson, and Mr. Harry Lyddon, General Foreman at Mandan, N. D., succeeds Mr. Barnes. Mr. W. L. Darling has been appointed Assistant Chief Engineer, with headquarters at St. Paul, Minn. Mr. E. M. Herr, Superintendent Motive Power, has resigned, and is succeeded by Mr. William Forsyth, formerly Mechanical Engineer of the C. B. & Q. R. R.

Port Jervis, Monticello & New York.—Mr. Addison B. Colvin has been chosen President, to succeed Mr. Thomas J. Waller, resigned.

South Atlantic & Ohio.—Mr. John M. King has been appointed Master Mechanic of the shops at Bristol, Va., and Tenn., succeeding Mr. E. M. Roberts, resigned.

San Diego, Pacific Beach & La Jolla.—Mr. S. C. Boutelle has resigned as Master Mechanic, on account of ill health.

Spokane Falls & Northern.—Mr. C. Shields has been elected Vice-President, with headquarters at Seattle, Wash.

Staten Island Rapid Transit.—Mr. J. Van Smith was appointed Receiver by the Supreme Court of the State of New York on July 14. Notice was given by President J. F. Emmons that all officers, agents, servants and employees were discharged July 14.

Toledo, Bowling Green & Vermont.—Mr. F. J. Hoag has been elected President.

Toledo, St. Louis & Kansas City.—Mr. T. C. Morris has been appointed Chief Engineer, with headquarters at Toledo.

Terre Haute & Indianapolis.—Mr. William Wright, formerly Chief Draughtsman of the Pennsylvania at Altoona, Pa., has been appointed Master Mechanic, with headquarters at Terre Haute, Ind.

Toluca & Tenango.—Mr. I. O. Nicholas, formerly Foreman at Toluca, Mex., of the Mexican Central, has been appointed Master Mechanic, succeeding Mr. E. W. Knapp, resigned.

Wisconsin Central Lines.—Mr. Angus Brown has been appointed Superintendent of Motive Power and Cars.

WANTED.

Inspector is open to an engagement to inspect the building of new rolling stock. Is an Ex-M. C. E., and familiar with M. C. B. rules of interchange, standards and testing of material, etc. All references. Address MECH. ENGINEER, care American Engineer.

LICENSES

To be sold in each district for Patent Safety Apparatus for Gage Glasses adaptable for any kind of steam boiler. United States Patent No. 409,280. Greatest success in Europe under Government control and legalized introduction. First class technical firms only are invited to correspond with

HERRN. LEYMANN & KEIM,

Aix La Chapelle, Germany.

AMERICAN ENGINEER CAR BUILDER AND RAILROAD JOURNAL.

OCTOBER, 1898.

CONTENTS.

ILLUSTRATED ARTICLES:	Page	MISCELLANEOUS ARTICLES:	Page
Locomotive Grates—M. N. Forney	323	Shansi Coal Mines—China	339
Ten-wheel Locomotives, Gt. N. Ry	326	Engineering Notes	342
Construction of a Modern Locomotive	329	Pressing Wheels on Axles	344
Narrow Gauge Locomotives for Mexico	333	Water Tube Boilers—U. S. S. "Marietta"	346
Two New Car Designs, N. P. Ry.	335	Master Mechanics' Association Committees	347
Simplex Bolster, C. & O. Ry.	337	Examination of Employees	347
Susomihl-Torrey Side Bearing	339	Tie-Plates—Roadmasters' Association	348
Superheater for Locomotives	344	Luxury in Siberia	349
Weed Burner, N. P. Ry	345	Cheap Railway Rates in Switzerland	349
Chicago & Milwaukee Electric Ry	346	Weights of M. C. B. Couplers	349
Search Light Attachment for Locomotives	347	Journal Bearings and Hot Boxes	350
Electrically Driven Angle Shears	348	Personals	351
The Bartow Bell Ringer	349	Books and Pamphlets	352
 MISCELLANEOUS ARTICLES:			
The Traveling Engineers' Association	325	EDITORIALS:	
John M. Toucey, Obituary	333	Side Bearings vs. Center Plates	340
Uniformity in Signaling	337	Home-Made Air Brake Parts	340
Grate Areas and Heating Surface	338	Track Tanks	340
Side Bearings for Cars	338	Breakage of Piston Rods	340
		The Dummy Coupling	341
		The Atlantic City Flyer—P. & R. Ry.	341

LOCOMOTIVE GRATES.

By M. N. Forney.

The letter of C. G. O. on this subject on page 260 of the August number of the "American Engineer" suggests some observations. The general principle, which has been enunciated, that: "Within the limits of weight and space to which a locomotive boiler is necessarily confined it cannot be made too large" is undoubtedly sound, but, as was suggested in the discussion at the Master Mechanics' Association, it is not so clear what proportion the grate area and the cubical contents of the fire-box should bear to the heating surface under any given conditions. In considering this question, two requirements must be kept in mind—1st, the maximum capacity of the locomotive to do work must be maintained, that is, it must be able to pull the heaviest possible load at the required speed, and 2nd, it should do this with a minimum consumption of fuel. Often these conditions are contradictory, that is, in order to pull the heaviest loads a locomotive must sometimes waste fuel, and, in many cases, it is more economical to do so than it would be to save coal by reducing the load hauled.

But suppose that in designing an engine every expedient and resource is adopted to reduce the weight of the parts. Having this object in view, the fact that small wheels weigh less than big ones would incline the designer to use the smallest driving-wheels which would be adapted to the service in which the engine is to be used. With wheels of reduced diameter smaller cylinders will be required, and lighter connections, axles, frames, etc., may be used. It will be supposed further that steel and wrought-iron are substituted, as far as possible, for cast-iron, that all the castings are re-designed, and their weight is diminished to the lowest possible limit consistent with safety, and that every detail of the machine is subjected to the scrutiny of the most skillful designers and the weights of all the parts are reduced as much as is practicable. If by these expedients the weight of the parts outside of the boiler are reduced, say 5,000 pounds, then, obviously, the boiler may be that much heavier without increasing the total weight of the locomotive. Furthermore, in choosing the plan of boiler let due consideration be given to the weights of the respective forms—which is not often done—and let the lightest form be selected. By the exercise of intelligence and the adoption of the expedients suggested it is not unreasonable to assume that a design for a locomotive of a given weight might be evolved, the boiler of which would have several hundred square feet more of heating surface than ordinary locomotives of a similar class. Now, with the increased heating surface, there would be much less difficulty in making steam at critical periods and with inferior fuel than there would be if the boiler was smaller. The difficulty with many—

perhaps most—locomotives is that they have insufficient boiler capacity to produce the maximum amount of steam required at some times and places. Consequently a large area of grate is required in order to consume the greatest possible quantity of fuel, and to do this a tremendous blast must be maintained, with all the evils of a high back pressure, and while great quantities of fuel are consumed, much of it escapes out of the chimney either in a solid or unburned gaseous form. At the same time the products of combustion must traverse the heating surfaces so rapidly that there is not time to transmit their heat to the water on the other side, and they escape out of the chimney at temperatures of from 800 to 1,000 degrees. An enormous waste is the result.

If the same quantity of fuel was consumed in a larger boiler, having more heating surface, it would generate more steam because the products of combustion would be exposed to more heating surface and for a longer time. Therefore less fuel need be burned to produce a given quantity of steam, and consequently the rate of consumption on the grate could be reduced with a corresponding improvement in the combustion and a resulting further economy. Paradoxical as it may seem, it would appear that with a boiler of ample size a smaller grate may be used than is required to produce the maximum results with insufficient heating surface.

But supposing that the boiler has been made as large as possible, the proper proportion of grate to the heating surface is still an open question. Of course much depends upon the quality of the fuel. If it is inferior, more must be burned to produce a given quantity of steam than would be required if it was of better quality, from which the well recognized inference is drawn that a larger grate is required with bad fuel than with good. The relation which should exist between the size of the grate and the quantity of the fuel will not be discussed now, attention will only be called to the general fact that a grate should always be large enough to consume enough of the poorest fuel that is used to supply the engine with steam at critical times and places, or when it is working hardest, which is usually on grades, or perhaps at points on the road where grades and curves occur simultaneously. Now, a grate large enough to burn sufficient of the poorest fuel which is used, to supply enough steam when the locomotive is working hardest, is quite sure to be too large when the engine is not working at its maximum capacity as on easy grades or on level parts of the line. This suggests that the size of the grate should be made variable. With this end in view a few years ago the writer designed such a grate, but which thus far has not been subjected to any other trial excepting that which it had to encounter in the Patent Office. The description of it in the patent specifications is perhaps as lucid as any which could be given and is therefore quoted:

In the operation of all steam and of some other classes of boilers, as well as in that of the various types of furnaces, the requirements of heat generation vary materially from time to time, a high degree of heat being necessary during certain periods and different lower degrees during others. This is notably the case in locomotive boilers, in which a large amount of steam must be generated when the engine is pulling heavy trains at high speeds or ascending steep grades, while on levels or descending grades or during stoppages much less heat is required. Therefore at certain times the fire must be stimulated to its utmost capacity and at others little or no steam need be generated, there being frequently occasions, as when standing at stations, in which steam generation is inconvenient as well as wasteful. It has been found in practice that substantial economy in the combustion of fuel is attained if there is great intensity of combustion—that is, if the draft of air through the fire is concentrated—and that if the aggregate area of the openings for the admission of air through the fire is greater than that which is required to generate a desired and determined amount of heat and steam the combustion is wasteful. For this reason it becomes desirable to regulate the aggregate area of air admission openings proportionately to the quantity of heat which may be demanded, for which purpose these improvements are designed and are desirably applicable without modification of other elements in fire boxes of any of the present constructions.

In the accompanying engravings, Fig. 1 is a vertical longitudinal central section through a locomotive fire box having my improvements applied; Fig. 2, a sectional plan of the same at the line x x of Fig. 1; Fig. 3, an end view as seen from the rear; Fig. 4, a transverse section at the line y y of Fig. 1; Fig. 5, a longitudinal section, on an enlarged scale, through the rear end portion of the fire box, showing the grate bars in vertical position; and Fig. 6, a similar section showing the bars as turned into a substantially horizontal position. The invention is particularly designed for use in connection with locomotive engine fire boxes, and is herein illustrated as applied in a rectangular fire box of such type, but is obviously equally applicable to furnaces of other descriptions. The grate bars, which are of the rocking class, are set transversely in the fire box 1, and are in this instance shown as made in triplet sections, composed of a central bar 2 and lateral bars 3 3, cast in a single piece and separated one from another (except as to connecting webs between

the bars) by intermediate air passages 4. Each section is provided with end journals or trunnions, which rest in segmental recesses in bearing bars 7, secured longitudinally in the fire box adjacent to its bottom. The grate sections are set at such distance apart that the transverse spaces 8 in the fire box between the outer bars of adjacent sections shall be equal in width, as nearly as may be, to the air passages 4 between the bars of the sections, said spaces, together with the passages 4, serving, when the bars stand in vertical position, to admit air from the ashpan 9 to and through the body of fuel supported upon the grate in the usual manner.

In order to enable the aggregate area of air admission through the grate to be regulated as from time to time desired, the grate bars are so constructed and relatively located that when turned horizontally, or nearly so, the air admission spaces above described shall be closed by the overlapping of the bars and the passage of air through said spaces consequently prevented. To this end the central bar 2 of each of the grate sections is projected above and below the planes of the upper and lower faces of the lateral bars 3 3, so that the sections being set at a proper distance apart the upper portion of the central bar of one section will overlap the lower portion of the central bar of an adjacent section when both are turned into substantially horizontal position, as shown in Fig. 6, and in the rear portion of the fire box in Fig. 1, the air admission passages between the bars and between the sections being thereby closed by said central bars, the traverse of which into and out of horizontal abutting position is unimpeded by reason of the lesser depth of the lateral bars.

To facilitate the turning of the grate bars, it is essential

the fire box. The levers 12 may project above the foot-plate, as shown, or they may be entirely below it, if desired, and the grate bars are moved by a removable hand lever 15, having a socket in its lower end adapted to engage the ends of the levers 12. A separate rocking lever 12 and connecting bar 11 are in the instance shown provided for each grate section; but, if preferred, a group of two or more sections may be coupled to a single lever and connecting bar. A dog or latch 16 is pivoted to each of the levers 12 in position to engage either of a pair of notches or shoulders on a segment 17, fixed to the foot-plate or other convenient part of the engine, so as to hold the lever 12 in forward or backward position, and thereby maintain the connected grate section or sections in vertical or in horizontal position, respectively.

What the result of a practical test of this device would be it is of course impossible to say in advance. Perhaps the result to be apprehended is, that the grate bars would be so warped and twisted by the heat of the fire as to become unworkable, and then again perhaps they would not.

The possibility of making a grate, the active area of combustion of which may be made variable, leads to further observations: At the Master Mechanics' convention last June the deduction of D. K. Clark was quoted that the larger the heating surface and the smaller the grate, provided you can burn enough fuel in it, the greater the economy. In his Railway Machinery he says: "Practically there can never be too much heating surface, as regards economical evaporation, but there may be too little; on the other hand, there may be too much grate area for economical evaporation, but there cannot be too little so long as the required rate of combustion does not exceed the limits to be defined." Again he said: "The grate should be kept as small as is consistent with the demand for steam, and the practicable rate of combustion. On the other hand there can be no economical objection to any

FIG. 1.

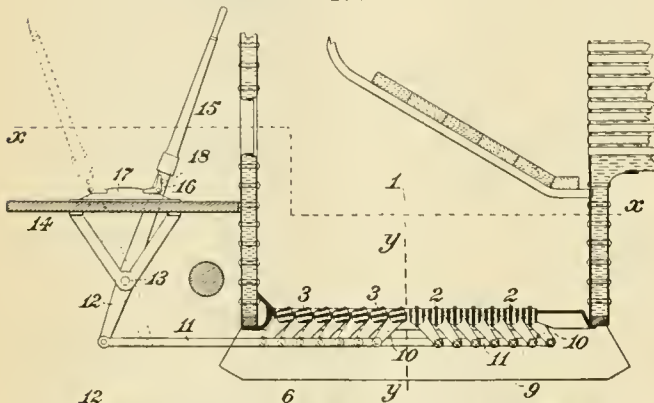

FIG. 2.

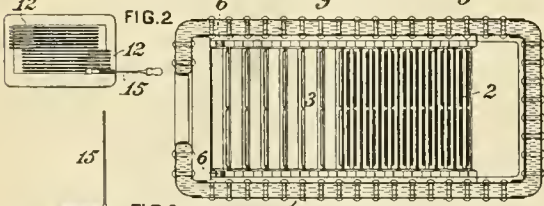

FIG. 3.

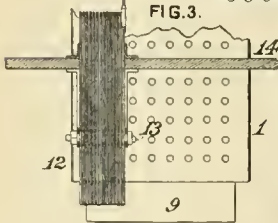

FIG. 4.

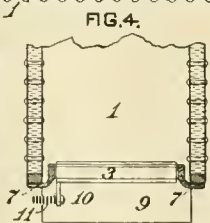

FIG. 5.

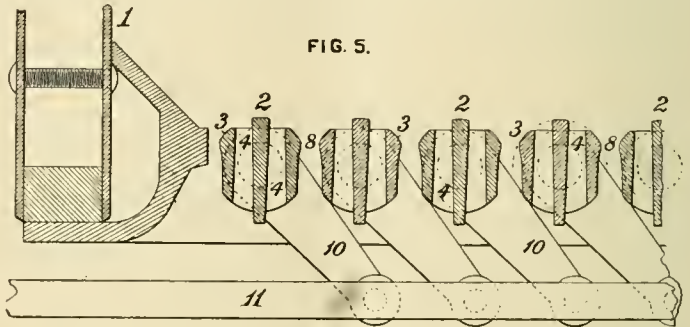
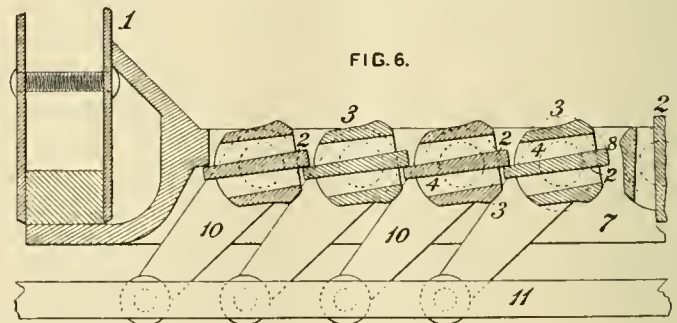

FIG. 6.



Locomotive Grates—M. N. Forney.

that the spaces between the sections should be maintained of uniform width, inasmuch as if these spaces should be contracted in the act of turning the bars, there is liability of cinders and coal becoming wedged between them, so as to prevent them from being moved. For this purpose the upper faces of the bars, or those adjacent to the fire, are curved in contour concentrically with the journals of the grate sections, as shown most clearly in the enlarged transverse sections, Figs. 5 and 6, and there being, consequently, no projection of any portion of said surfaces beyond the curved plane of traverse of the edges of the bars in being turned in their bearings the width of the space 8 between a bar which is moved and an adjoining stationary bar is neither increased nor diminished in the movement of the former.

The several grate sections are adapted to be turned from vertical to horizontal position, and vice versa, in groups or series of any desired number, so that a greater or less area of air admission passages may be closed or left open, as required. Each section is provided with a downwardly projecting arm 10, which is coupled at its lower end to a separate horizontal bar 11. The rear ends of the bars 11 are coupled to the lower ends of levers 12, which are journaled upon a common pivot 13, attached to the frame or to the foot-plate 14 in rear of

amount of heating surface which can be got into a boiler, even though greater than the economic limits." It has been pointed out that enlarging the grate increases the maximum steaming capacity of a boiler, for the reason that more fuel can be consumed in a large grate than in a small one, but the addition to the steaming capacity is made with a reduction of economy. It then follows that if the area of the grate is increased to meet the requirements of the greatest demands for steam when the engine is working hardest it will be very much too large for economy when under ordinary conditions of working. Or in other words, if the area of the grate could be reduced when a locomotive is not working hard, a material economy in the consumption of fuel would result. This is the object aimed at in designing the grate illustrated herewith, and it is thought would be attained if no serious practical difficulties are encountered in its use.

The reason why it is more economical to burn a given quantity of fuel in a small grate than in a large one is due in part to the fact that with a rapid rate of combustion higher temperatures are produced in the fire, and as the transmission of

heat to the water is proportioned to the difference in temperature in the two sides of the heating surfaces, a larger proportion of the heat is absorbed by the water when there is a great difference than when there is little. Besides this, if the temperatures are high, the volume of the products of combustion containing a given number of units of heat is less than it is if the temperature is lower. Or in other words, with a small grate and a rapid rate of combustion there will be fewer cubic feet of smoke and gases to convey from the fire to the chimney; consequently their movement may be slower and more time will thus be given for the transmission of their heat to the surfaces with which they are in contact.

Of course the size of the grate must be adapted to the quality of the fuel. With a poor fuel more must be burned to produce a certain quantity of steam in a given time, and therefore with such fuel a larger grate will be required. Kent, in his excellent Pocket Book for Mechanical Engineers, says:

"With good coal, low in ash, approximately equal results may be obtained with large grate-surface and light draught, and with small grate-surface and strong draft, the total amount of coal burned per hour being the same in both cases. With good, bituminous coal, low in ash, the best results, apparently, are obtained with strong draught and high rates of combustion, provided the grate-surfaces are cut down so that the total coal burned per hour is not too great for the capacity of the heating surface to absorb the heat produced." This indicates what is undoubtedly true, that the draught must be adapted to the size of the grate, and the quality of the fuel. A stronger draught is required if a small grate is used than is needed with a larger one.

Very little attention seems to have been given thus far to the proportion which the volume of space in the fire-box, above the grate, should bear to its area. It is believed that the relation of these to each other is of much more importance than is ordinarily supposed. Some years ago Frederick Siemens in a paper on combustion, and the construction of furnaces—which has heretofore been quoted in these pages—called attention to the fact that whenever flame comes in contact with any solid substance combustion is arrested, which fact, he said, could be illustrated by putting a rod into the flame of an ordinary gas light, which would then immediately begin to smoke. His inference was that furnaces should be constructed so as to keep the flame out of contact with their sides and tops until the process of combustion is completed. A homely illustration of the embodiment of this principle is ordinary egg-shaped stoves for burning bituminous coal. They have grates comparatively small in area, and the space above them swells out to an approximately pear-shaped form. The enlarged space above the fire gives room for combustion to take place before the gases pass into the chimney. A similar form is adopted for smelting furnaces and cupolas. The design of ordinary locomotives is such that the available width of their fire-boxes is usually limited by the space between the frames or between the wheels. Comparatively narrow fire-boxes are therefore the rule. The fire-boxes of the Wooten boiler are placed above the wheels so that they may be made as wide as the cab, but with a diminished depth. The adoption of the Columbia and Atlantic types of engines, with their fire-boxes entirely behind the driving-axes, will make wider fire-boxes possible, and open a new era in their proportions, which invites attention to the relation which should exist between the volume of space in the fire-box, and the size of the grate. It seems probable that the amount of this space has a very important bearing on the economy of fuel consumption. We are certainly now very much in the dark with reference to the whole matter. If the possibility of a saving of a few thousand dollars by litigation can be shown to a railroad company, they usually show no hesitation in employing the most able lawyers to represent and advocate its interests, but, quite curiously, when it can be shown almost to a demonstration that an investigation requiring engineering knowledge, skill and experience would save many thousands of dollars, it is difficult to induce them to expend a cent for such information.

Consideration of the question of combustion has suggested the following conclusions: First, there should be as much heating surface as the limits of weight and space will permit; second, the grate should be large enough to burn sufficient coal to generate sufficient steam to supply the engine when it is doing its maximum work. The area of grate required for this will depend upon the quality of the fuel. Third, if practicable, the grate ought to be adjustable, so that its active area may be diminished or increased to meet the varying conditions of working. Fourth, the length and depth and breadth of the fire-box should be as nearly alike as is practicable, so as to keep the flame out of contact with its sides and top, and thus give time for combustion to take place, and for the same reason dead-plates should be put around the grate, next the sides and ends of the fire-box.

THE TRAVELING ENGINEERS' ASSOCIATION.

The sixth annual convention of the Traveling Engineers' Association was held at Buffalo, beginning September 13. The reports were interesting and practical, as usual, but they are so long that we cannot do more than call attention to the chief of the points involved in them. The first subject was:

What is the Best Method to be Pursued by Traveling Engineers in Giving Air Brake Instruction While on the Road?—A great deal of very good advice is given in this paper, which is of equal value to old traveling engineers as to new ones. The first principle laid down is that instructors should themselves become proficient in all of the duties of engineers, and should be prepared to handle brakes on any part of the road. Many of the common practices that are wrong are deprecated, among which are the wasting of air by unnecessary applications and releases, and the holding of the brakes too long and giving a disagreeable lurch to the train by too late release. The causes of the sticking of brakes are important, and enginemen should be familiar with them. The effect of a partially closed angle cock in the train upon the noise of the train pipe exhaust should be understood, and this was not given enough attention by engineers. The influence of piston travel and the effect of closed retaining valves were considered. The proper method of handling trains partly equipped with air brakes was stated to be directly opposite to the method required on the Chicago, Rock Island & Pacific. The hand brakes should be set on the cars immediately behind the air braked cars, as that is the place where the slack may be controlled. Independent driver brakes and the use of retaining valves on locomotives to assist in making tank stops are considered along with a number of other important details.

How Can the Traveling Engineer Best Instruct and Assist the Fireman in the Economical Firing of the Locomotive?—The essence of this report is that the traveling engineer should be thoroughly prepared to do that which he is expected to instruct others to do. The necessity of getting trains over the road and on time must not be lost sight of, and with due consideration of this the engineman should be brought to see his responsibility for the proper use of the fuel handled by the fireman. It is a wise plan to furnish firemen with good literature on the subject of combustion in locomotive fireboxes, and the practice of traveling engineers in riding with new firemen until they are thoroughly qualified to do their work economically is recommended. Encouragement of the men is advocated. The draft appliances are often to blame for waste of fuel, and more attention to the front end arrangements was shown to be necessary.

Uniformity of Cab Fittings.—The steam connections to the boiler should all be combined in one fitting or combination stand, making but one connection with the boiler. The throttle should be so located that it might be reached by the engineer when leaning out of the window, and in short the arrangement of the cab fittings should be made with reference to the convenience of the men. It was very desirable to have the engines arranged with uniformity, and standards were advocated.

Lubrication of Locomotives.—This report was prepared from answers to questions asked by the committee, and is divided into three parts: First, proper fitting of bearings; second, quality of lubricant; third, manner of applying the lubricant to the bearings. The burnish or roller finish is advised for all journals and crank pins. There was a difference of opinion as to the proper maximum length of run for one oiling, but the committee thought that 100 miles was about right. The oiling of the driving boxes, shoes and valve gear should be done as late as possible before starting, and it was recommended that the work of packing, driving and truck boxes should be placed in the hands of a competent man, who should attend to all of this work. The practice of facing the hubs of driving wheels with Babbitt metal was endorsed, and the use of oil cans fitted with valves to regulate the flow of oil was recommended.

The Use of Water on Hot Bearings of Engines and Tenders.—The majority favored the use of water in streams upon hot journals, and it was quite customary to fit pipes to tender tanks in order to reach the tender truck boxes easily, but it was more difficult to reach the driving and engine truck boxes. The water was sometimes taken from the feed pipe to the injector, and if lifting injectors were used the discharge pipe was tapped. This gave hot water, but by nearly closing the injector down the temperature might be reduced to about 90 degrees.

The cost of extra fuel required to light a train of ten cars by an English system of dynamos driven from the axles of the cars at ordinary speeds is one-half pound per train mile, according to the "Railroad Gazette."

TEN-WHEEL PASSENGER LOCOMOTIVES—GREAT NORTHERN RAILWAY.

The recent improvement of the locomotive equipment on the Great Northern Railway includes a new design of very heavy passenger locomotives built by the Brooks Locomotive Works, of Dunkirk, N. Y. Eight of these engines have been in service for four months, and they are reported to be giving very satisfactory results. They are the heaviest passenger

stroke, these dimensions and the weight being in accordance with the ideas of Mr. J. J. Hill, President of the road. In general, the details are in accordance with the practice of these builders, and by comparison with the details of the

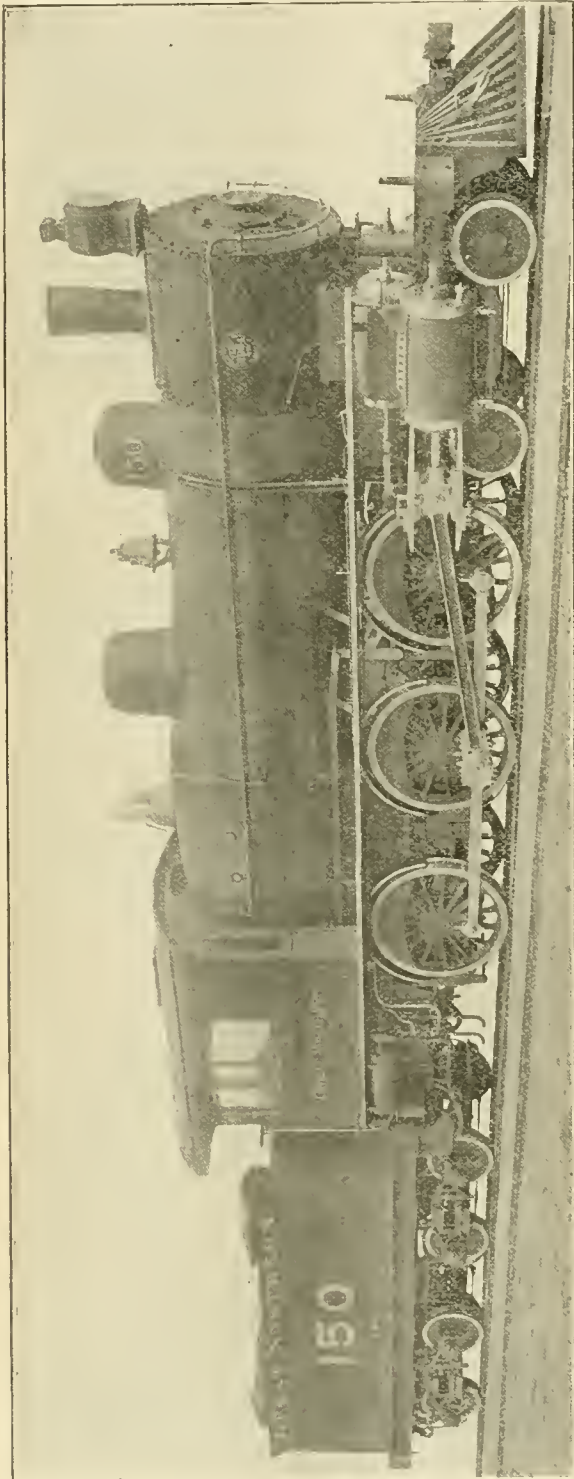

From a Photograph.

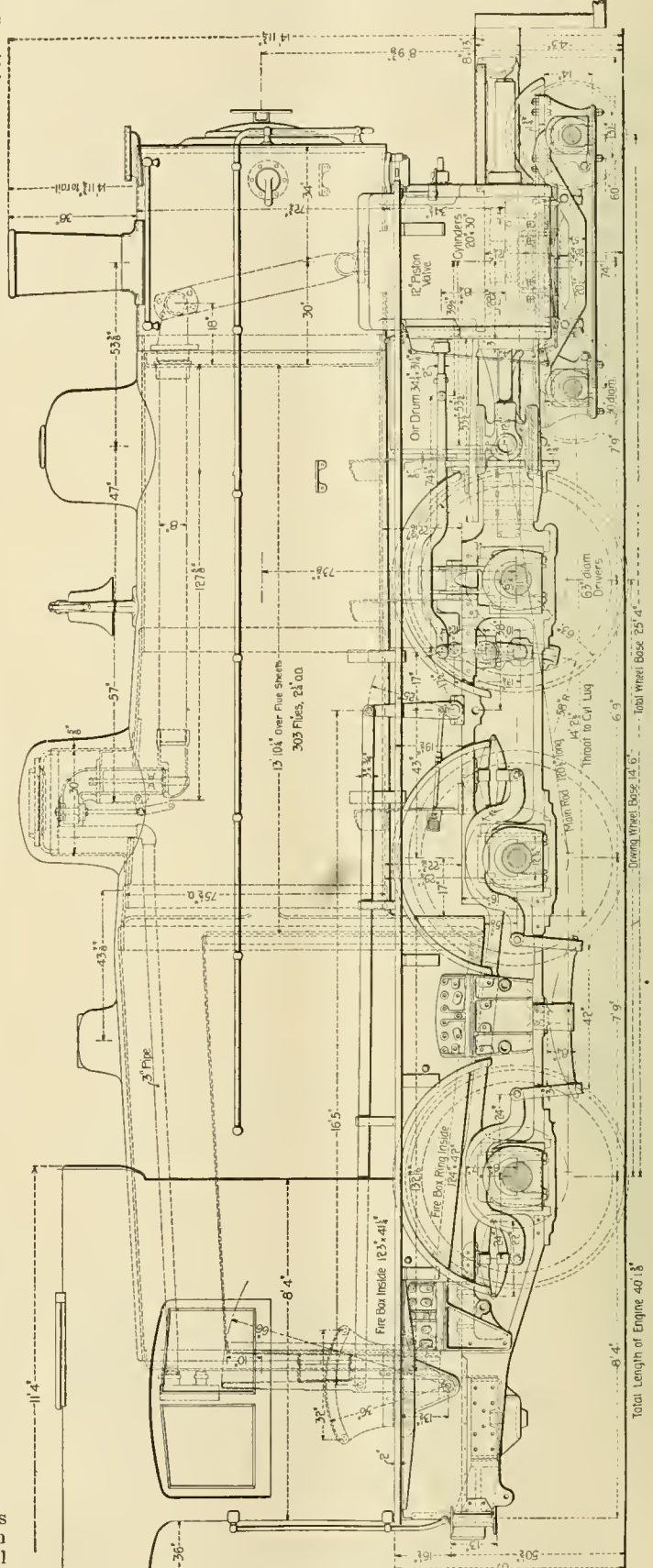

Longitudinal Section.
Ten-Wheel Passenger Locomotive—Great Northern Railway.

BROOKS LOCOMOTIVE WORKS, BUILDERS.

J. O. PATTEE, Superintendent Motive Power.

locomotives ever built and a comparison with the dimensions and weight of the engines of the same type of the Southern Railway, illustrated in our issue of March 1898, page 82, will be interesting. The total weight of the Southern engine is 158,000 pounds, and the weight on drivers is 121,250 pounds, while the corresponding weights of the Great Northern design are 166,000 pounds and 129,500 pounds.

The cylinders are 20 inches in diameter by 30 inches

engines of the same type for the Wisconsin Central (see "American Engineer," June, 1898, pp. 190-193), a similarity in general details will be found, except that the Wisconsin Central engines are much lighter, the total weight being 150,000

pounds and the weight on drivers 116,000 pounds. The Wisconsin Central engines exert a draw-bar pull of 30,000 pounds, and the Great Northern engines give a maximum pull of 36,000 pounds. These figures are given by the builders. The draw-bar pull at 66 per cent. cut-off is given at 32,500 pounds. These figures give co-efficients of adhesion of 3.6 and 3.9, respectively.

The driving wheels are 63 inches in diameter, which, with the long stroke, will give high piston speeds. The boiler is

hle without using the compound principle. The grate area is 35.4 square feet and the firebox, which is on top of the frames and slopes downward toward the front, is 123 in. long and 41½ in. wide. Its depth is 80 in. in front and 62 in. at the back. The water spaces are given in the table and it will be noticed that they begin to enlarge below the point of curvature in the side sheets. The horizontal seams are sextuple riveted with lap joints, the object being to lighten the seam and make it

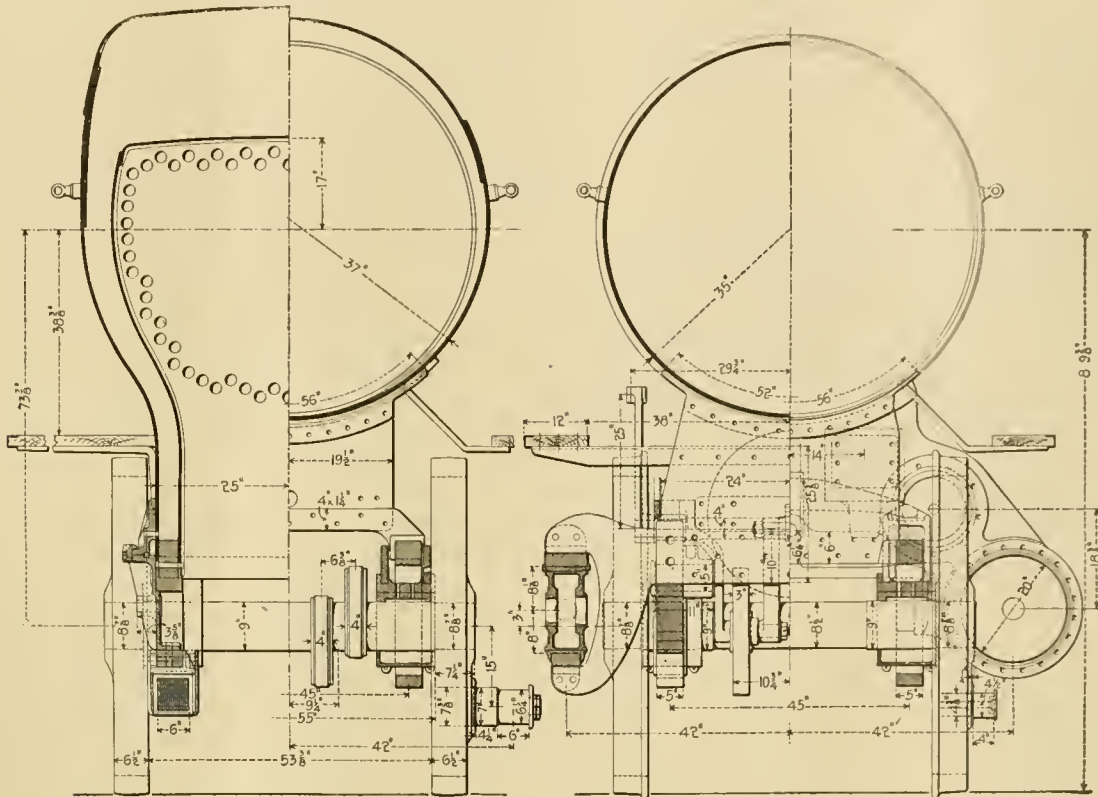

Transverse Sections.

GENERAL LOG OF RESULTS.

LOCOMOTIVE TESTS ON THE GREAT NORTHERN RAILWAY BETWEEN CLANCY AND WOODVILLE.

	Pass.	Freight.		Pass.	Freight.
Engine, No.	154	154	Engine No.	154	154
Date of trial.	7-28-98	7-29-98	Number of miles per ton of coal.	13.2	8.3
Length of run, miles	48.1	48.1	Lbs. of coal used per hour.	152	211
Kind of service, freight or passenger.	P	F	Coal used per 100 tons of train per mile	52.7	41.0
Weather.	Fine.	Fine.	Coal used per 100 tons of train back of tender per mile.	96.8	57.9
Mean temperature of the atmosphere.	76°	85°	Coal used per 100 tons of train between tender and way ear, per mile	58.9
Wind.	Very Light.	Very Light.	Weight of coal burned while throttle was open	7,050 lbs.	11,300 lbs.
Condition of rail.	Good.	Good.	Average weight of coal burned per sq. ft. of grate per hour while throttle was open.	127 lbs.	101 lbs.
Size of exhaust nozzle, single	5½ in.	5½ in.	Weight of water drawn from tank, lbs.	35,000	59,600
Time on the road	2 h. 17 m.	4 h. 35 m.	Waste of injector	225	240
Actual time in motion	1 h. 50 m.	3 h. 34 m.	Weight of feed water	34,775	59,360
Aggregate intermediate stops, minutes	27	61	Temperature of feed water	56°	56°
Time during which power was developed	1 h. 34 m.	3 h. 10 m.	Water used per mile, lbs.	724 lbs.	1,235 lbs.
Maximum speed, miles per hour	49.5	33.8	" " 100 tons of train per mile.	251 lbs.	225 lbs.
Average	26.2	13.5	Water used per 100 tons of train behind tender per mile	461 lbs.	296 lbs.
Maximum revolutions per minute	264	180	Water used per 100 tons of train between tender and way ear per mile.	301 lbs.
Maximum piston speed, feet per minute.	1,320	900	Water used per hour, lbs.	22,160 lbs.	18,750 lbs.
Minimum seconds per mile	72.9	106	" " sq. ft. of heating surf. per hour	8.28 lbs.	7.01 lbs.
Maximum boiler pressure	210	210	" " " " " " " " " " " "	626 lbs.	529 lbs.
Minimum	175	165	Actual evaporation per lb. of coal	4.93 lbs.	5.27 lbs.
Average	196.4	198	Equivalent " from and at 212° per lb. coal	6.00 lbs.	6.40 lbs.
Prevailing position of throttle-lift	0.5 ins.	0.5 ins.	Maximum I. H. P. developed	1,468	1,116
" throttle opening, square inches	16.6	16.6	Average	922	839
" position of the reverse lever	7 & 10	7, 10 & 18	Coal per I. H. P. per hour, lbs.	4.87	4.26
" cut-off, inches.	{ 7 in. & 10 in.	{ 7 in., 10 in. & 18 in.	Water per I. H. P. per hour, lbs.	21	22.4
" " per cent. stroke	23 & 33	23, 33 & 60	Average No. of sq. ft. of heat surf. per I. H. P.	2.9	3.19
Weight of train in tons of 2,000 lbs., inclusive of locomotive and tender.	289	549	Average No. of I. H. P. per sq. ft. of grate surf.	25.1	23.6
Wt of train, excl. of loco. and tender, tons.	157	417	Maximum grade, feet per mile.	116	116
" " " " tender & way car, tons	410	Average rise, feet per mile.	64.7	64.7
No. of cars.	5	11			
" " loads.	10			
Total weight of coal consumed, lbs.	7,300	11,600			

large, the diameter of the first course is 70 in., and the heating surface is 2,677 square feet, of which 225 square feet is in the firebox and the arch tubes. This is the largest heating surface used in passenger service, but it will all be needed for these large cylinders, and we wonder whether the results will justify the employment of single expansion cylinders. The steam pressure is 210 lbs., and this makes it evident that the object was to obtain as great a ratio of expansion as possi-

more flexible than the butt joint. All the shell seams except those for the back head and the front flue sheet are triple riveted with 1½ in. rivets at 3¼ in. pitch. The firebox flue sheet is ½ in. thick and the front one is ¾ in. thick. Bell's spark arrester and short front end, which has been used in a number of large Brooks engines is employed and it is giving excellent results, both as a spark arrester and in free steaming.

The arrangement of the cylinders and piston valves is the

same as in the Wisconsin Central engines except that the Great Northern engines have extended piston rods. The frames of the engine are 5 in. wide except at the front and back ends, where they were formed into slabs; at the cylinders they are

forms the support for the cab deck and running boards. The running boards, engine decks and tender deck are on one level. The tender has a capacity for 4,500 gallons of water and 8 tons of coal, together weighing 96,000 lbs.

The spring rigging is similar to that of the Wisconsin Central engines (see American Engineer, 1898, p. 190) with the front driving wheels equalized across the engine by means of a heavy leaf spring. The main equalizers are in the form of 42 in. leaf springs, and the outer ends of the driving box levers bear on 22 in. elliptic springs. The driver brake shoes bear against the rear of the wheels and the cylinders are inside the frames, just in front of the rocker boxes. The injectors and checks are inside the cab.

The indicator cards are reproduced because of the interest in piston valves. They were taken in tests of one of the engines in freight and passenger service and the data reproduced here were taken by the builders. We would like to compare these figures with results obtained upon a stationary testing plant, but this cannot be done, and as our readers may like to see the results of road tests they are given the opportunity.

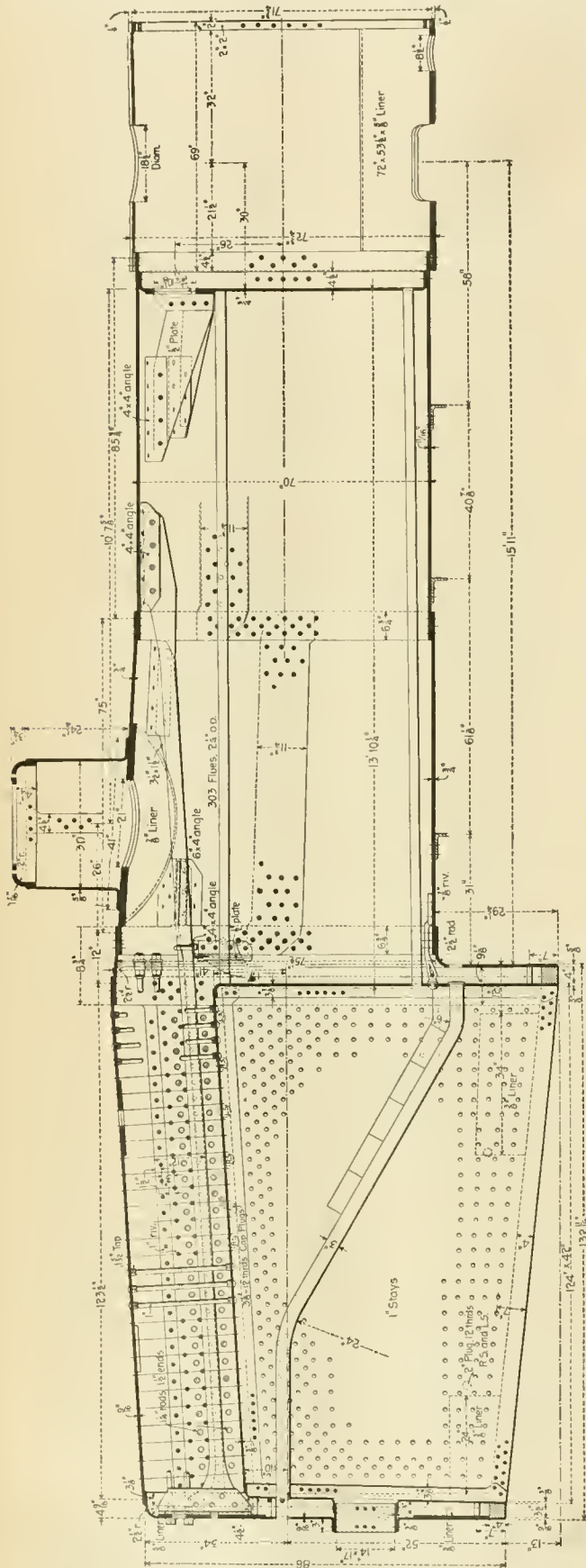

Ten-Wheel Passenger Locomotive—Great Northern Railway—Longitudinal Section of Boiler.

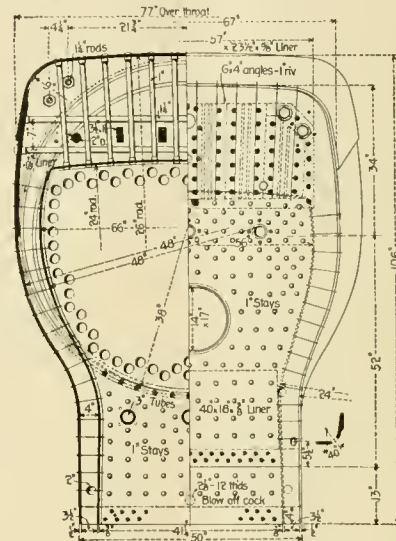

Transverse Sections of Boiler.

We do not take much stock in road tests, however, for comparisons. The cab log shows the minimum steam pressure to be 165 lbs. in freight and 175 lbs. in passenger service, and the average pressures were 198 and 196.4, respectively. The trains were light but the grades averaged 64.7 feet per mile for the 48 miles. The water per horse power is given at 24 lbs. for passenger service and 22.4 for freight. It is worth noting that the record is much better in freight than in passenger service. The indicator cards were taken with the other records, at each mile post, the left side of the engine being indicated with a 120 lb. spring for passenger service, and the right side with a 150 lb. spring for freight. The chief dimensions of the engine follow:

DESCRIPTION.

Type	ten-wheel passenger
Gauge	4 feet 8 1/2 inches
Kind of fuel	Bituminous coal
Weight on drivers	129,500 pounds
" on trucks	36,500 pounds
" total	166,000 pounds
" tender loaded	96,000 pounds
Wheel base, total, of engine	25 feet 4 inches
" driving	14 feet 6 inches
" total, engine and tender	53 feet 7 1/2 inches
Length over all, engine	40 feet 1 3/8 inches
" total, engine and tender	62 feet 2 3/8 inches
Height, center of boiler above rails	3 feet 9 3/8 inches
of stack above rails	14 feet 11 3/4 inches
Heating surface, firebox and arch pipes	225 square feet
" tubes	2,452 square feet
" total	2,677 square feet
Grate area	35.4 square feet
Wheels and Journals.	
Drivers, number	6
" diameter	63 inches
" material of centers	Cast steel
Truck wheels, diameter	30 inches
Journals, driving axle, main9 by 11 inches
" driving axle, front and back9 by 11 inches
" truck	5 1/2 by 12 inches
Main crank pin, size	6 3/4 by 6 inches
Cylinders.	
Cylinders, diameter	20 inches
Piston, stroke	30 inches
Piston rod, diameter	4 inches
Main rod, length, center to center	120 1/2 inches
Steam ports, length	18 inches
" width	2 inches
Exhaust ports, length	56 inches
" least area	66.5 square inches
Bridge, width	2 1/2 inches

3 1/2 by 10 in. section. The front ends are connected by a heavy 13 in. channel and the back ends by two lighter channels of the same height, with a 3/8 in. vertical plate between them. This

Valves, kinds of	Valves.	Improved piston
" greatest tavel		7 inches
" steam lap (inside)		1 1/2 inches
" exhaust lap or clearance (outside)		3/4 inch
Lead in full gear		1-16 inch negative
" constant or variable		Variable
Boiler, type of	Boiler.	Player improved Belpaire
" working steam pressure		210 pounds
" material in barrel		Steel
" thickness in barrel		11-16 inches
" tube sheet		3/4 inch
" diameter of barrel		70 inches
Seams, kind of horizontal		Sextuple
" circumferential		Double and triple
Crown sheet, stayed with		Direct stays
Dome, diameter		30 inches

Firebox, type	Firebox.	Long, sloping
" length		123 inches
" width		41 1/4 inches
" depth front		.80 inches
" back		.62 inches
" material		Steel
" thickness of sheets:		
crown, 3/4 inch; tube, 5/8 inch; side and back, 3/4 inch		
" brick arch		On water tubes
" mud ring width:		
back, 3 1/2 inches; sides, 3 1/2 inches; front, 4 inches		
" water space at top:		
back, 4 1/2 inches; sides, 6 inches; front, 4 inches		

Speed, 9 M. P. H.
Boiler pressure, 200 lbs.



M. E. P., 171.5. M. E. P., 165.
I. H. P., 188.

Speed, 48 M. P. H.
Boiler pressure, 195 lbs.

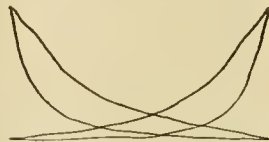

M. E. P., 33.6. M. E. P., 30.3.
I. H. P., 196. I. H. P., 184.

Speed, 27 M. P. H.
Pressure, 200 lbs.



M. E. P., 55.1. M. E. P., 59.1.
I. H. P., 182. I. H. P., 202.

Speed, 34 M. P. H.
Pressure, 205 lbs.



M. E. P., 88.8. M. E. P., 90.
I. H. P., 367. I. H. P., 386.

Indicator Cards.

Grates, kind of	Cast iron, rocking
Tubes, number of	303
" material	Charcoal iron
" outside diameter	2 1/4 inches
" thickness	No. 11 B. W. G.
" Length over tube sheets	13 feet 10 1/4 inches

Smokebox.

Smokebox, diameter outside	72 3/4 inches
" length from flue sheet	64 inches

Other Parts.

Exhaust nozzle, single or double	Single
" " variable or permanent	Permanent
" diameter	5 inches, 5 1/2-16 inches, 5 3/4 inches
" distance of tip below center of boiler	1 inch
Netting, wire or plate	Wire
" size of mesh or perforation	2 1/2 by 2 1/2 and 2 1/4 by 1 1/4
Stack, straight or taper	Steel taper
" least diameter	15 7/8 inches
" greatest diameter	18 7/8 inches
" height above smokebox	38 inches

Tender.

Type	Eight-wheel, steel frame
Tank, capacity for water	4,500 gallons
" coal	8 tons
Type of under frame	Steel channel
Diameter of wheels	33 inches
" and length of journals	4 1/4 by 8 inches
Distance between centers of journals	4 feet 10 inches
Diameter of wheel fit on axle	5 3/8 inches
" center of axle	4 1/4 inches
Length of tender over bumper beam	21 feet 4 inches
" tank	19 feet 6 inches
Width of tank	8 feet 8 inches
Height of tank, not including collar	55 inches
Type of draw gear	M. C. B. standard

Special Equipment.

Brakes	N. Y. automatic for drivers, tender and train service
Pump	No. 2, New York
Sight feed lubricators	Nathan
Safety valves	Crosby
Injectors	New Nathan No. 10 and Monitor No. 10
Springs	A. French Spring Co.

The Young Men's Christian Association, at its West Side Branch, 318 West 57th street, New York, opens an evening school Oct. 3 for young men who are engaged in business during the day. Its rooms are well equipped, and the usual courses of instruction, including mechanical drawing, have been provided. Information may be had from the Secretary at the address given above.

THE CONSTRUCTION OF A MODERN LOCOMOTIVE.*

By T. R. Browne.

V.
MACHINE SHOP.

The amount and kind of equipment necessary in this department, its relation to the maintenance of the equipment in other departments, as well as its relation to the character of its finished product, considered from the standpoint of quantity, interchangeability and cost, renders the machine shop one of the most important departments of the whole plant. For the amount of floor space usually covered the total investment in equipment is very much greater than any of the other departments in the construction of locomotives, and not only the



Fig. 1.

equipment, but the organization and character of supervision in connection with the equipment must be of the highest order to secure the best results and the proper earnings per square foot of surface inclosed and occupied by and per dollar invested in equipment.

Tool Department.—For the purpose of keeping in repair all of the facilities and equipment throughout the plant, not only in the interest of lowest cost, but in order that the repairs may be made in the most intelligent and expeditious manner, it has been found advisable to include in the organization of this shop a department known as a tool department, in charge of a competent foreman, who is responsible for all of the tools and equipment used in production throughout the plant. If convenient, in each one of the other departments a mechanic is



Fig. 2.

located who reports directly to the foreman of the tool department and represents that department in the shop in which he is placed.

The frequent and intelligent inspection, followed by prompt repairs of all the equipment throughout the plant by this department, leaves only for the foremen of the various departments in which the equipment is placed the supervision of their equipment incidental to the production of the greatest amount of output. It will also have a tendency to improve the character and standardize the class of repairs made to tools and machinery at a very much less expense than would be the case were these repairs governed by the judgment of the different

* For previous article, see page 187.

foremen of departments in which this equipment is operated. It is assumed—and not without good reason—that the supervision of the men employed and the operation of the facilities in his department to the best advantage will employ the entire time of the foreman of that department, and to much better advantage, everything considered, than would be the case were he expected also to keep his equipment in perfect repair. It is necessary at times that the tool department should consist of a very much larger force than that necessary to operate the machines in the manufacture of small tools. This additional force required for ordinary and extraordinary repairs in the various departments is provided by those departments in which the work is to be done, the men for the time being working

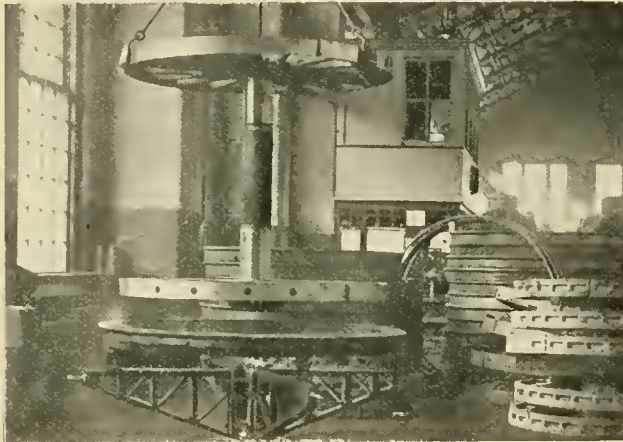

Fig. 3.

under orders of the foreman of the tool department. All of the time and material used in repairs to facilities in the various departments is charged to the annual work orders issued to these departments and referred to in earlier articles. The large variety of small tools of peculiar nature which cannot be purchased, together with jigs, fixtures, gauges, etc., required in the production of duplicate parts of a locomotive, are also made in the tool department, which also has charge of the various tool rooms throughout the plant, keeping a record of tools broken by carelessness or otherwise and making regular reports to the office of the superintendent.

In addition to the tool department there should be included in the organization of the machine shop certain subdivisions



Fig. 5.

or sub-departments, known as a wheel and axle department, brass department and vise department.

With the exception mentioned in a previous article on the blacksmith shop all of the machine work necessary for finishing the parts used in the construction of a locomotive to exact sizes should be concentrated where the majority of that character of facilities exist, and the advantages of concentrating as much as possible the various kinds of machinery used for this purpose will be apparent. This being the case, with the exception of the boiler, the machine department will furnish to the erecting shop all of the parts necessary for the complete erection of the engine, of course not including the wood work

and work of a similar character, the metal parts for which will be furnished to the department in which this work is done by the machine shop.

Laying Out Work.—A general introduction of piece work necessitates a careful inspection of output and the variety and size of parts, the frequent uning off or laying out of such portions as are to be machined. The most economical arrangement of labor provides in most cases a class of men operating



Fig. 4.

the machines, who, while good operators, are not sufficiently skilled either in the reading of drawings or laying off of their own work to be depended on, and to provide for this division of the work an additional department, known as the laying off department, and in charge of a leading man, is provided. The force which he will require is recruited from the most progressive and best educated men of the shop, who act as inspectors, not only of the material delivered from other shops to the machine shop, but of the finished product from this shop.

A complete system of solid gauges, both for inside and outside measurement, is provided, and to these gauges all of the parts on which they are to be used are finished. They prac-



Fig. 6.

tically cover all of the operations comprised in milling, slotting, planing, etc., and are subject to frequent check with master gauges kept in the tool department. Sheet iron templates are provided for the marking off of holes for drilling where the parts are of such size or shape as to interfere with the use of regular drilling jigs. In the case of cylinders, saddles, etc., cast iron drilling jigs are provided, which are bolted to the casting and not removed until all of the holes indicated in the jigs are drilled. It is usually sufficient in jigs of this character to provide not more than two bushings, which can be removed and inserted in succeeding holes in the jigs during the operation of drilling. Jigs of this kind are provided for drill-

SCHEDULES FOR LOCOMOTIVE WORK.

Schedule "A," Boiler and Mountings.

1.

The boiler, with flues, washout plugs or flanged connections for washing out, and provided with all such holes or connections as can be made in the boiler shop expeditiously, and such parts rivetted on at that point, and furnished to the erecting shop ready for the mounting.

Hopper box.
Side caps.
Dry pipe braces.
Checks.
Washouts.
Tee head studs.
Dry pipe sleeves and bolts.
Dry pipe hangers and bolts.
Tee heads and joints.
Throttle valve.
Throttle valve chamber and bolts.
Upright steam pipe and bolts.
Dome sheets.
Front tube sheets.
Mud ring—braces and bolts.
Smoke box ring and union ring for smoke box, and union ring for smoke box to boiler.
Sand box base.
Sand box top.
Fire box doors and frames.
Fire box door forgings.

2.

Sand boxes complete.
Bells and yokes.
Throttle rod ends and stuffing boxes.
Supplemental dome.
Cab saddle.
Bridge pipe and flanges, also valve.
Lubricator stand and base.
Engineer's brake valve stand and base.
Steam gauge stand and base.
Injector pipe brackets.
Stack base.
Stack base ring and top.
Headlight brackets.

3.

Cocks and valves.
Supplemental dome cap and casing.
Main dome cap and joints.
Hip castings.
Air brake brackets.
Steam pipes, with joints.
Exhaust boxes.
Jacket angle irons.
Netting angle irons.
Front end for smoke box and door.
Hand rail columns and bases.
Exhaust nozzles.
Shaking grates.
Damper rigging forgings.
Whistle and connections.
Injectors and pipes.

Engineer's brake valve.
Signal lamp brackets.
Drip pan.
Waste pipe clamps.
Air pump air reservoirs.
Badge plates.

Schedule "B," Frame Work.

1.

All bolts and studs used in frame work.
Main frames.
Cylinders.
Front end frames.
Bumper castings.
Smoke box braces.
Pedestal caps.
Pedestal bolts.
Driver brake brackets.
Frame stiffening pieces.
Equalizer posts.
Foot plates and bushings.
Cab brackets.
Engine steps.
Cross pedestal braces.
Frame braces.
Spring hangers.
Driver brake fulcrums.
Buffer castings and springs.
Back cylinder heads.
Guide yoke and knees.
Rockers and rocker boxes.
Lift shaft and bearings.
Guides.
Guide bolts.

2.

Steam chests and casings.
Steam chest lids.
Front cylinder heads.
Front cylinder head casings.
Pressure plates.
All spring rigging not included in No. 1.

3.

Schedule "C," Wheel Work and Engine Trucks.

1.

Driving boxes, with cellars, keys, bushings, etc.

2.

Driving wheel centers.
Driving axles.
Keys for driving axles.
Crank pins.
Dowel screws for crank pin washers.
Crank pin washers.
Truck frames.
Truck pedestals.
Truck centers.
Truck spring seats.
Truck braces.
Truck springs.
Truck spring hangers, with thimbles and bolts.

Truck spiders.
Truck boxes, with cellars, keys and brasses.
Wheels and axles.
Truck brake complete.
Sponging in truck boxes.

Schedule "D," Tank and Tender Work.

1.

Tanks and tender frames, including flooring, couplers and connection, painted.
Tender trucks complete.

2.

To include all water scoop, steam heat, air brake and signal work.
Draft irons.

Schedule "E," General Erection and Completion of Engine.

1.

Boiler, as per schedule "A."
Frames, as per schedule "B."
All bolts, studs and nuts.
Pads.
Running board brackets.
Side irons.
Cab brackets.

2.

Links and hangers.
Boiler tested.
Lagging or boiler covering put on.

3.

Cab.
Wheels put under engine.
Spring rigging connected.
Valve rod and eccentric rods.
Foot plates and running boards.
Jacket finished.
Dome casing put on.
Pipes, air and driver brake, connected.
Pistons put in.
Main rods fitted.
Engine generally finished and inspected, previous to going to paint shop.

Schedule "F," Final Test and Inspection of Engine.

1.

Engine returned to erecting shop from paint shop.
Side rods put on.
Headlight.
Tender to engine.
Tank hose and tank cock.

2.

Engine steamed up.
All air and injector pipes tested.
Air pipes blown out.
Generally inspected.
Sent up for test.

ing the holes for cylinder head and steam chest studs, and the one for cylinder head studs so arranged as to answer for the cylinder heads. In the case of the back cylinder head, the jig is located with reference to a center line, and holes are provided in it for drilling the holes for guide bolts. This same center line is used in erecting, and it will be obvious that holes drilled in this way will do away with the necessity of specially hanging the guides. A jig is used on the guide yoke, which is adjustable for the back end bolt holes, and the operation for hanging the guides is not only simplified, but reduced in cost when it comes to a point of erection. The accuracy attainable in the construction of a boiler, due to the system of lining and fitting up, described in a previous article, permits of almost final machining of the cylinder saddles where they fit the front end or extension. An auxiliary bar made to a radius equal to the radius of the front end and carrying a tool head, will permit of planing these saddles to the required shape, and save the time usually taken by chipping. The center marks can be made on this bar corresponding to the center marks on the cylinder, and made at a point located with reference to the frame fits and saddle joint, giving most accurate results in finished cylinders.

Schedule of Parts.—In an earlier article reference was made to a schedule of the various parts required and the order in which they were to be gotten out by the various departments throughout the works. A copy of this schedule is given below. This schedule is not intended to cover with the greatest accuracy all the parts that are required, but only sufficiently to provide a general guide for the various departments in which

either a part or whole of these parts may be prepared.* It has been found that the smaller details, which may be omitted, are generally of such a nature as to be finished in ample time for general erection.

Schedule for Turning Out Standard Locomotive Work.

The various schedules and subdivisions of material or parts for locomotives shall be designated by the letters "A," "B," "C," "D," "E" and "F." Those parts under the division numbers shall be turned out in the order in which they are numbered; that is to say, No. 1, Schedule "A," signifies that all of the parts numbered "1" are to be turned out first on the schedule. This explanation of one instance answers for all similar cases in the following schedules. These numbers refer to the connection that these parts have with the expeditious completion of the engines, working under the best advantage.

The order in which these parts are required is in accordance with the methods of erection followed in the erecting department, because all of the departments throughout the works are contributive to that department, and work in accordance with its demands.

The various processes through which the parts required in a modern locomotive have to pass in the machine shop are sufficiently familiar to make unnecessary any detailed description, with possibly the exception of a few cases, which are exceptions to ordinary practice.

In the wheel and axle department all of the operations necessary to prepare the wheels for placing under the engine are conducted. Figs. 1, 2, 3 and 4 illustrate the method of heating with crude oil for the purpose of expanding the tires, pre-

paratory to putting them on the centers; Fig. 1 showing a pair of tires during the process of heating, Fig. 2 the temporary removal of the top tire until the center can be dropped in as illustrated in Fig. 3, when the tire shown in Fig. 2 is put in place, as illustrated in Fig. 4. The device shown is caused to rotate by hand or motor, the furnace remaining stationary, but adjustable for different diameters of tires.

With the introduction of bronze hub liners, cast directly on the wheel, it became necessary to adopt a simple and efficient method of doing this work in the shop. Figs. 5 and 6 illustrate a small furnace operated with oil and used for this pur-

which may exist, can be made so close to size that an operation of grinding will be all of the finish required.

It has been found thoroughly practicable to produce in all of the parts having any connection with the link or valve motion a finish sufficiently accurate to not only make these parts thoroughly interchangeable, but the operation of actually setting the valves on the locomotive in its final erection unnecessary. In connection especially with the parts used in the link and valve motion, a system of mechanical inspection is provided for by a set of jigs for each operation, and so arranged that a previous operation, if not exactly correct, will

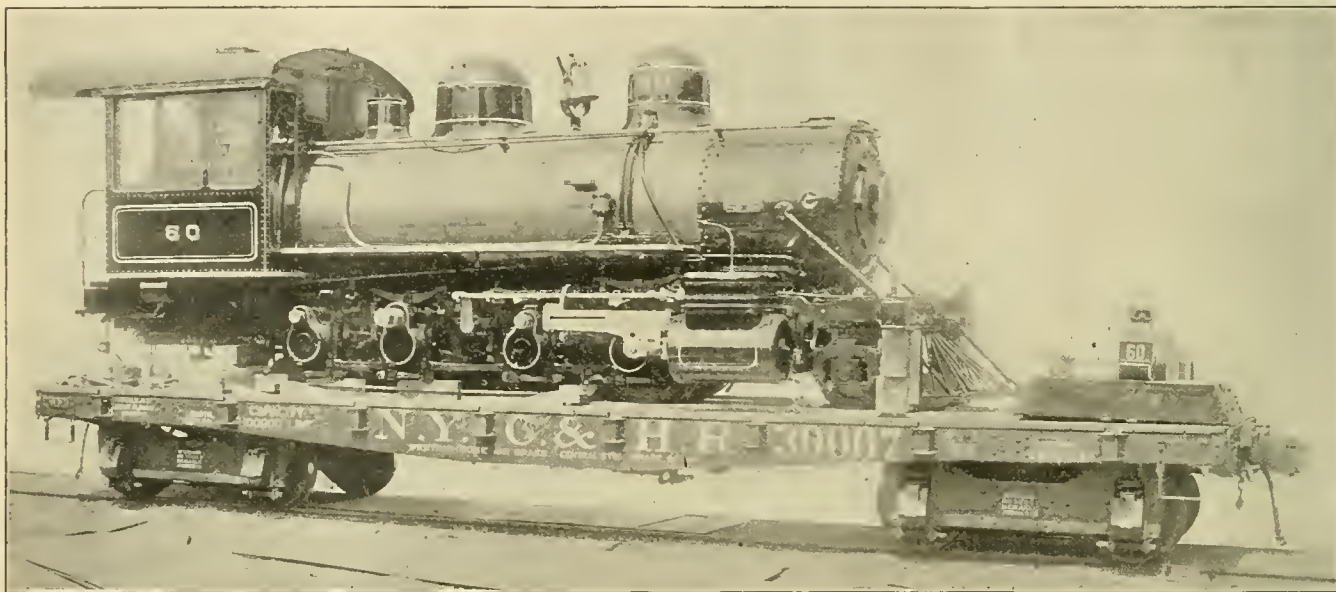

Narrow Gauge Locomotive for Interoceanic Railway of Mexico, Shipped on Fox Steel Car

pose, the bronze being melted in the crucible and the crucible, as shown in Fig. 6, used as a pouring ladle.

All of the pin fits are bored to solid gauge and the pins turned to a solid gauge, allowance for tonnage being made in the gauges. These gauges are made hollow, and have wooden handles to prevent excessive expansion.

A complete equipment of turret machinery with the box form of tools arranged for standard forms of brass work will produce parts of this character at the lowest cost and in largest quantities. These tools are arranged with reference to a succession of operations, each tool is numbered, and they are adjusted in the machine for a given kind of work by a skilled

mechanic. The operator of the machine is not necessarily a mechanic, and, in fact, a man of quite ordinary attainments becomes exceedingly skillful in a short space of time on this class of work.

The use of carefully made dies for forming, by hydraulic pressure, the various smaller types of forgings required, will very materially reduce the amount of machine work and finishing necessary in the machine shop. In fact nearly, if not all, of the forgings of a smaller type which require finish, either for running fit or for the purpose of showing up any defects

prevent the part in question being placed in the jig used for the next succeeding operation. It will be obvious that with the links, bridles, hanger rods, eccentric and various other vital parts of the link motion prepared in this way, there is no reason why not only these parts should interchange on various engines of the same type and size, but that if this degree of accuracy is carried out through the other parts having any connection with the link motion, the results will be accurate in the extreme.

In the case of eccentrics, the keyways are cut after the eccentrics are bored, the eccentric mounted on a mandrel having a corresponding keyway, and the mandrel set at the proper de-

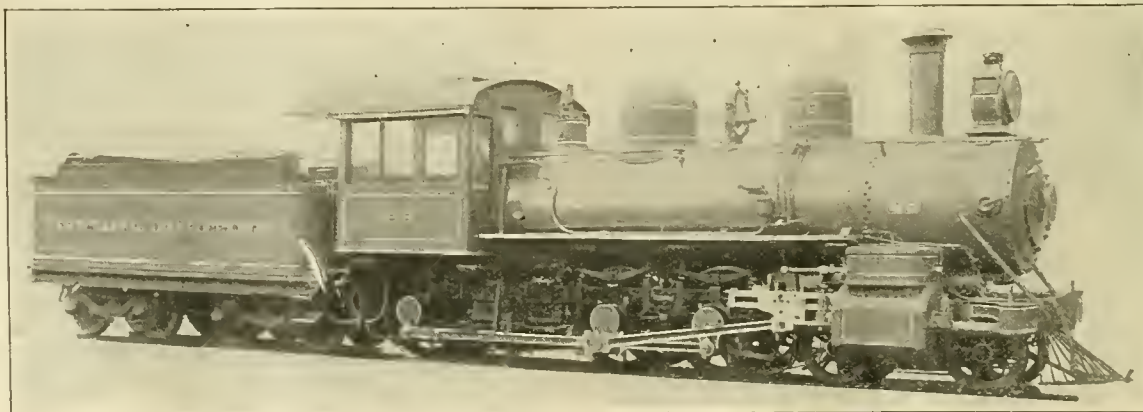

Ten-Wheel Schenectady Compound Locomotive—Interoceanic Railway of Mexico.

gree of advance; or, in other words, a mandrel or jig practically takes the place of the axle with the exception that its center is the center of the eccentric. The outside portions of the eccentric are finished while it is mounted on this mandrel. A center punch mark is made in the eccentric by a punch located in this mandrel at the proper point, indicating a position of full forward when the eccentric shall have been placed on the axle. The operation of clamping the eccentric on the mandrel causes the punch to make the mark. In the process of erection a tram is used, one end resting in this center punch mark and

mechanic. The operator of the machine is not necessarily a mechanic, and, in fact, a man of quite ordinary attainments becomes exceedingly skillful in a short space of time on this class of work.

The use of carefully made dies for forming, by hydraulic pressure, the various smaller types of forgings required, will very materially reduce the amount of machine work and finishing necessary in the machine shop. In fact nearly, if not all, of the forgings of a smaller type which require finish, either for running fit or for the purpose of showing up any defects

gree of advance; or, in other words, a mandrel or jig practically takes the place of the axle with the exception that its center is the center of the eccentric. The outside portions of the eccentric are finished while it is mounted on this mandrel. A center punch mark is made in the eccentric by a punch located in this mandrel at the proper point, indicating a position of full forward when the eccentric shall have been placed on the axle. The operation of clamping the eccentric on the mandrel causes the punch to make the mark. In the process of erection a tram is used, one end resting in this center punch mark and

the other in the center of the eccentric rod jaw pin, thus providing for the accurate setting of the eccentric rod. The keyways in the axle for eccentrics are located in the same position, namely, on a center line through the axle and pin fit on all classes of engines, any change in the angle of advance being made in the eccentrics themselves. This provides that these keyways can be milled before the axles are mounted in the centers, and not only provides an exceedingly accurate method of location, but saves the time usually taken by the old method of drilling and chipping these keyways after their location has been found and when the wheels are under the engine.

A complete overhead track system with pneumatic hoists in this department, as well as throughout the whole shop, provides an easy and convenient method of handling the various smaller parts which are not handled by the large crane, as well as largely reducing the fixed charges for labor.

JOHN M. TOUCEY.

John M. Toucey, formerly General Manager of the New York Central & Hudson River Railroad, died at his home at Garrison's, New York, Sept. 23, after an illness of several months. He leaves a widow and one son. For about a year his health had been poor, and when he retired from the management of the road, last May, he became rapidly worse, and in spite of all efforts and changes of climate he gradually failed. He began his railroad work at the age of 20 years, in 1848, and never left it until last May. His first position was station agent on the Naugatuck Railroad. He went to the New York Central in 1855, and in 1862 was appointed Assistant Superintendent. From 1867 to 1881 he was Superintendent of the Hudson River Division, and from 1881 to 1890 he was General Superintendent, becoming General Manager of the whole road in 1890. A number of changes were made when Mr. S. R. Callaway took the Presidency last Spring, the position of General Manager being abolished, and Mr. Toucey was made Assistant to the President. He resigned this position and was honored by a pension. Mr. Chauncey M. Depew pays the following tribute to Mr. Toucey:

"Mr. Toucey was with the New York Central for over forty years. He began as a conductor and advanced step by step to the post of General Manager. For the last thirty years I knew him intimately. I always regarded him as one of the ablest railway operators in the country. In the field of managing trains he had few if any equals. He had in particular the gift of moving traffic and passengers with great expeditiousness on time and with a maximum good for the company at a minimum cost. His record was extraordinary, in that with the immense amount of traffic that he handled, he met with so few accidents. He was loyal to a fault, and simple-minded in his honesty. His dominant trait was fidelity—fidelity to his friends and to his company. He had a host of friends and was well known to railroad men all over the world."

NARROW GAUGE LOCOMOTIVES—INTEROCEANIC RAILWAY, MEXICO.

Through the courtesy of the Schenectady Locomotive Works, we have received photographs and particulars of two designs of narrow-gauge locomotives built by them for the Interoceanic Railway of Mexico. Two of the ten-wheel compounds and six of the simple consolidations have been built in accordance with specifications arranged in consultation with Mr. Henry E. Walker, Locomotive and Car Superintendent of the road. The consolidations are in service, and very favorable reports of their operation have been made. They have straight boilers and the fuel is coal briquettes. The cranks are outside of the frames, while the driving wheels, owing to the narrow gauge of 3 feet, are inside, the driving boxes being faced with bronze on both bearing surfaces.

One of the engravings shows the novel method of shipping an engine of the consolidation type upon one of the new steel flat cars of 100,000 pounds capacity of the New York Central & Hudson River Railroad. This car is one of a lot made by the Fox Pressed Steel Equipment Company, and erected at the West Albany shops of the road in April of the present year. The weight of the locomotive, as shown, is 83,000 pounds, and the weight of the car is 29,000 pounds. The length of the car is 36 feet 8 inches and its width is 9 feet 8 11-16 inches, the height from rail to floor being 3 feet 8 3/4 inches. The low floor permits of carrying the locomotive, which would not be possible with a high car without stripping the engine of many of its parts. The car has the new Fox trucks, with 5 by 9 inch M. C.

B. journals. We shall have more to say about the interesting car in a future issue.

The special equipment of its engines includes for both types the following: Crosby safety valves, steam gauges and whistles, Nathan sight feed lubricators, Westinghouse automatic air brakes on tenders and for trains, and Leach sanders. The consolidation engines have magnesia sectional lagging on boilers and cylinders and the ten-wheelers have the American outside equalized air brake on all driving wheels.

General Dimensions.		10-Wheel Compound.	Consolidation.
Gauge		3 ft. 0 in.	
Fuel		Coal briquettes.	
Weight in working order	90,500 lbs.		91,000 lbs.
" on drivers	58,000 lbs.		82,000 lbs.
Wheel base, driving	13 ft. 2 in.		10 ft. 11 in.
" total	22 ft. 5 in.		17 ft. 2 in.
Cylinders.			
Diam. of cylinders	H. P., 17 in.; L. P., 27 in.		16 in.
Stroke of piston	20 in.		20 in.
Horizontal thickness of piston	4 3/4 in.		5 1/4 in.
Diam. of piston rod	2 3/4 in.		2 1/2 in.
Kind of packing		Cast iron.	
" rod packing		U. S. Metallic.	
Size of steam ports			
H. P., 15 in. x 1 1/2 in.; L. P., 18 in. x 2 in.			14 in. x 1 1/4 in.
Size of exhaust ports			
H. P., 15 x 2 1/4; L. P., 18 in. x 2 1/4 in.			14 in. x 2 1/2 in.
Size of bridge ports	14 in.		1 in.
Valves.			
Kind of slide valves	Allen Richardson.		Richardson.
Greatest travel of slide valves	5 1/2 in.		
Outside lap of slide valves			
H. P., 1 1/8 in.; L. P., 3/4 in.			3/4 in.
Inside lap of slide valve	Clearance 1/4 in.		Line and line, 0 in.
Lead of valves in full gear	1/16 in.		0 in.
Kind of valve stem packing		U. S. Metallic.	
Wheels, Etc.			
Diam. of driving wheel outside of tire	48 in.		38 in.
Mat'l " centers		Cast steel.	
Tire held by		Shrinkage and lip.	
		Cast steel.	
Driving box material			
Diam. and length of driving journals			
7 in. dia. x 7 in.			7 in. dia. x 7 in.
Diam. and length of main crank pin journals			
(main side, 5 1/2 in. x 4 in.); 4 1/2 in. dia. x 4 1/2 in.			Main, 4 1/2 x 4 1/2 in.; main side 5 1/2 in. x 4 in.; inter., 7 in. dia. x 3 1/2 in.
Diam. and length of side rod crank pin journals			
3 1/2 in. dia. x 3 in.			3 in. dia. x 3 in.
Engine truck, Kind	4-wheel swing bolster.		2-wheel swing bolster.
journals	4 3/4 in. dia. x 7 in.		4 in. dia. x 7 in.
Diam. of engine truck wheels	31 in.		25 in.
Boiler.			
Style		Straight.	
Outside diam. of first ring	52 in.		56 in.
Working pressure	200 lbs.		180 lbs.
Mat'l of barrel and outside of fire box		Carbon steel.	
Thickness of plates in barrel and outside of fire box	16 in., 5/8 in., 7/16 in., 1/2 in.		9/16 and 1/2 in.
Horizontal seams		Butt joints, sextuple riveted, with welt strips inside and outside.	
		Double riveted.	
Circumferential seams			
Fire box, length	49 9/16 in.		54 in.
" width	44 3/4 in.		44 3/4 in.
" depth	61 in.		60 1/2 in.
" material		Carbon steel.	
" plates, thickness, sides		5/16 in.; back, 5/16 in.; crown, 3/8 in.; tube sheet, 1/2 in.	
Fire box, water space, front		3 in.; sides, 2 1/2 in. to 3 in.; back, 2 1/2 in. to 4 in.	
Fire box, crown staying		Radial, 1 in. dia.	
stay bolts		3/4 in. and 1 in. dia.	
Tubes, material		Charcoal iron.	
" number of	199		179
" diam.	1 3/4 in.		2 in.
" length over tube sheets	10 ft. 7 in.		14 ft. 6 in.
Fire brick supported on		Studs.	
Heating surface, tubes	1,048.33 sq. ft.		1,351.18 sq. ft.
" fire box	81.94 sq. ft.		81.60 sq. ft.
" total	1,130.47 sq. ft.		1,440.75 sq. ft.
Grate surface	15.33 sq. ft.		16.96 sq. ft.
Ash pan, style		Plain dampers.	
Exhaust nozzles	4 in., 4 1/4 in., 4 1/2 in. dia.		3 3/4 in., 4 in., 4 1/4 in. dia.
Smoke stack, inside diameter		14 in.	
" top above rail	12 ft. 2 1/2 in.		12 ft. 1 1/2 in.
Boiler supplied by	2 Sellers Class N.		2 Sellers No. 7 1/2
Tender.			
Weight, empty	31,000 lbs.		
Wheels, number of	8		
" diam.	31 in.		
Journals, " and length	4 in dia. x 7 in.		
Wheel base	14 ft. 0 1/2 in.		
Tender frame	8 ft. channel.		
" trucks, 4 whl. square wrot. iron frame.			Square wrot. iron frame.
Water capacity	3,000 U. S. gals.		
Coal	5 1/4 tons.		4 1/2 tons.
Total wheel base of engine and tender	45 ft. 3 1/2 in.		45 ft. 10 1/2 in.
Total length of engine and tender	53 ft. 1 1/2 in.		53 ft. 11 in.

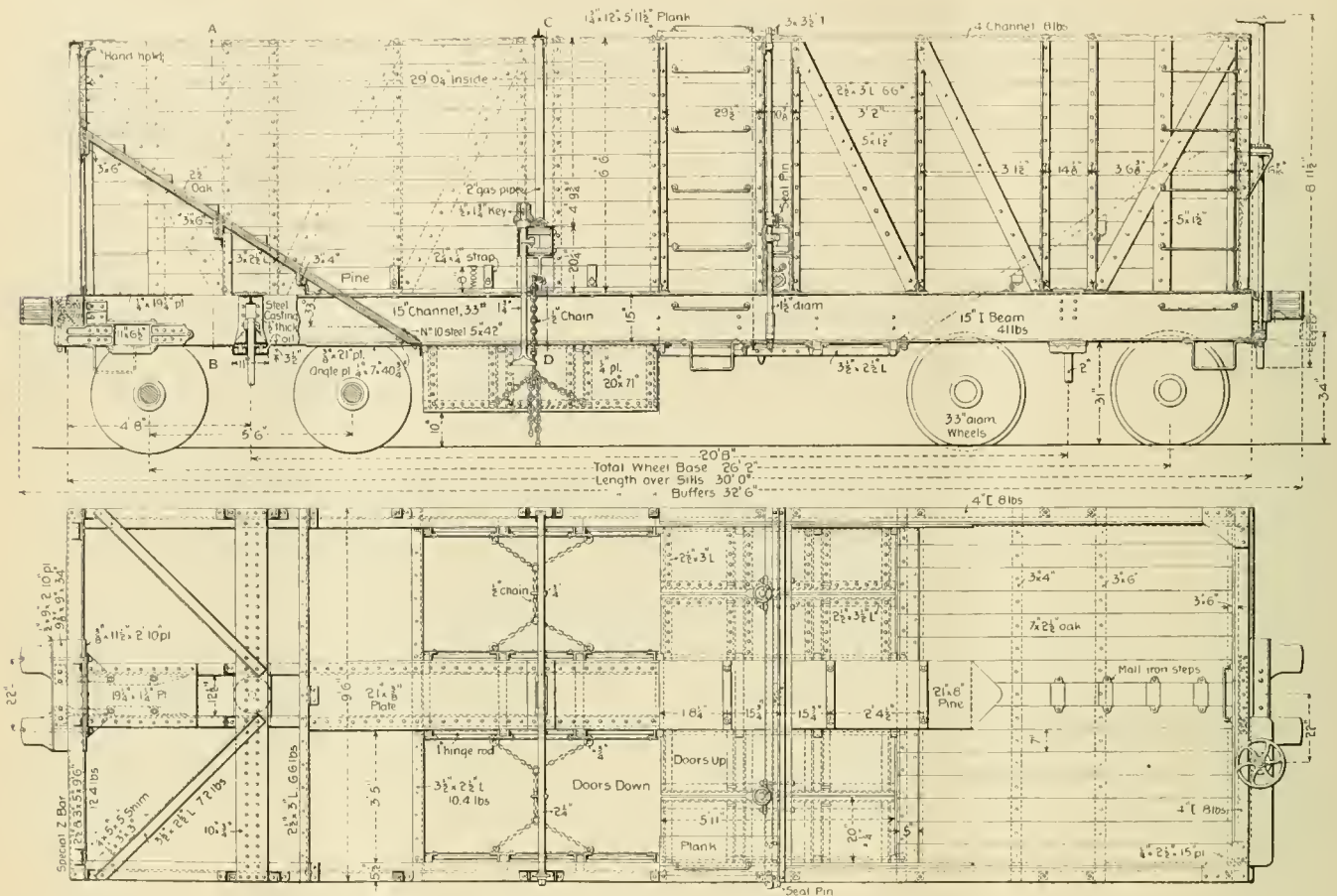

Longitudinal Sections, Elevation and Plan.

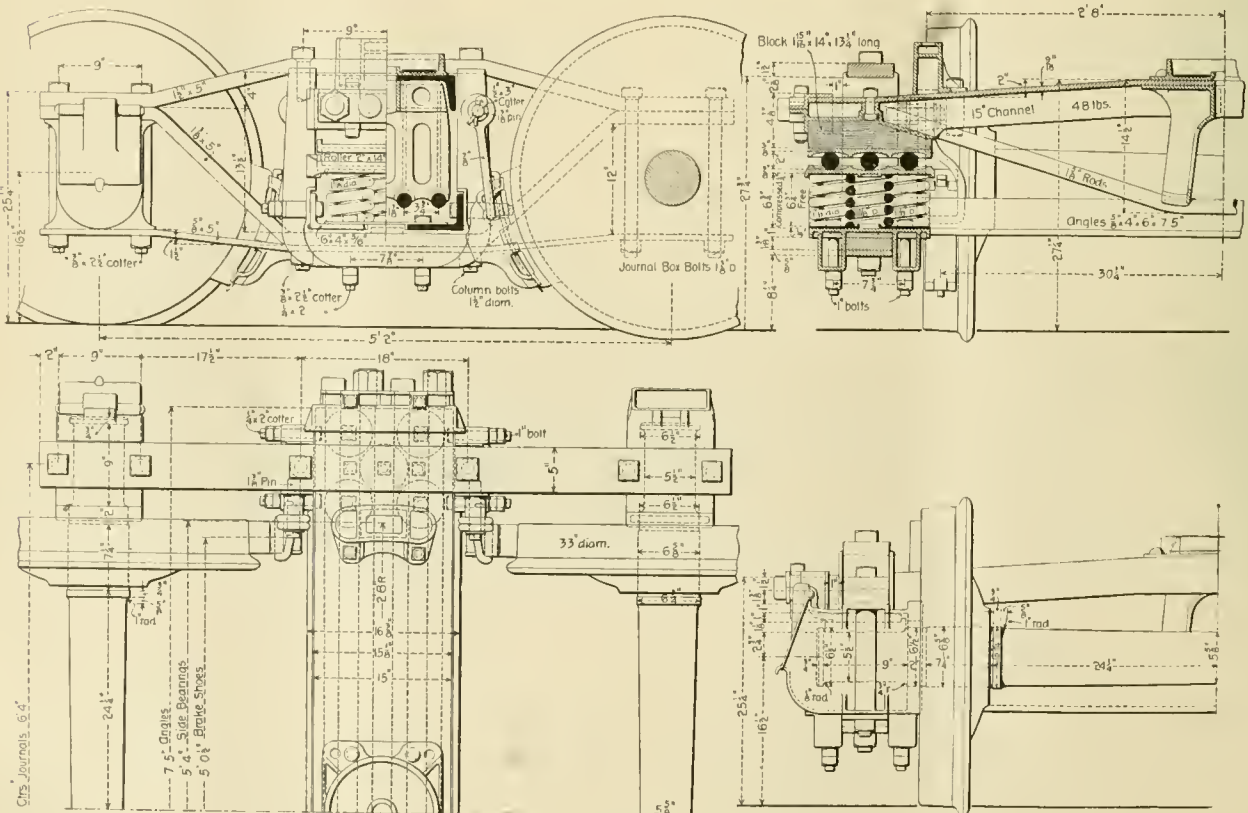

Details of Truck and Truck Bolster.

Coal and Ore Car, 100,000 Lbs. Capacity, Northern Pacific Railway.

TWO NEW CAR DESIGNS—NORTHERN PACIFIC RAILWAY.

COAL AND ORE CAR, 100,000 POUNDS CAPACITY.

A hopper bottom coal car of 50 tons capacity, only 30 feet long and weighing 35,000 pounds, is a novelty even in steel car construction, and through the courtesy of Mr. E. M. Herr, who has just resigned as Superintendent of Motive Power of the Northern Pacific Railway, we are enabled to present an illustrated description of the interesting design, prepared under his direction, from which an experimental car is now being built for that road with a view of building a number for coal and ore service.

The car has a steel underframe and a wooden box, with sides

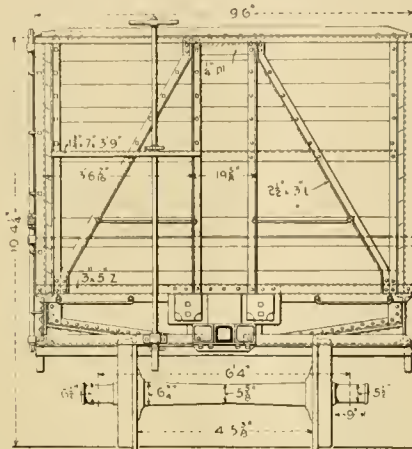

End Elevations and Sections—Coal and Ore Car.

6 feet 6 inches high. The length over sills is 30 feet; the width over sills, 9 feet 6 inches; the height of body, 7 feet 9 inches; the height from rail to top of plate, 10 feet 4 3/4 inches, and the distance from center to center of trucks is 20 feet 8 inches. The drawings, which are reproduced in as much detail as possible, are worthy of study.

The underframe is very stiff, notwithstanding the presence of the hoppers, which renders it necessary to get along without intermediate sills. The center sills are in the form of a box

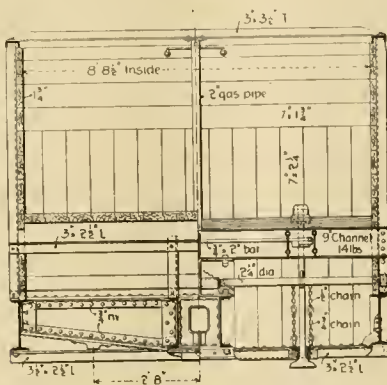

Cross-Sections of Coal and Ore Car.

girder constructed with 15-inch channels weighing 33 pounds per foot and 7-16 by 21 inch covering plates. The side sills are of 15-inch I beams, weighing 50 pounds per foot. The end sills are of special Z bars 2 1/2 and 3 by 5 inches by 9 feet 6 inches. The dead blocks are secured to plates fastened to the ends of the box girder. The end and intermediate bracing is clearly shown in the drawings. The body bolsters have 3/4 by 10 inch bottom and top plates with a center web 3/8 inch thick and fastened together by 2 1/2 by 3/8 inch angles, the form of the bolsters being shown in the half section on line A—B. This view also shows the connection between the box girder and the

bolsters, where it will be noticed that the cover plates extend over and under the box girder, while the webs of the bolsters are riveted to the channels of the girder. The center castings are of cast steel, riveted to the plates and channels of the girder. The center plates are of malleable iron.

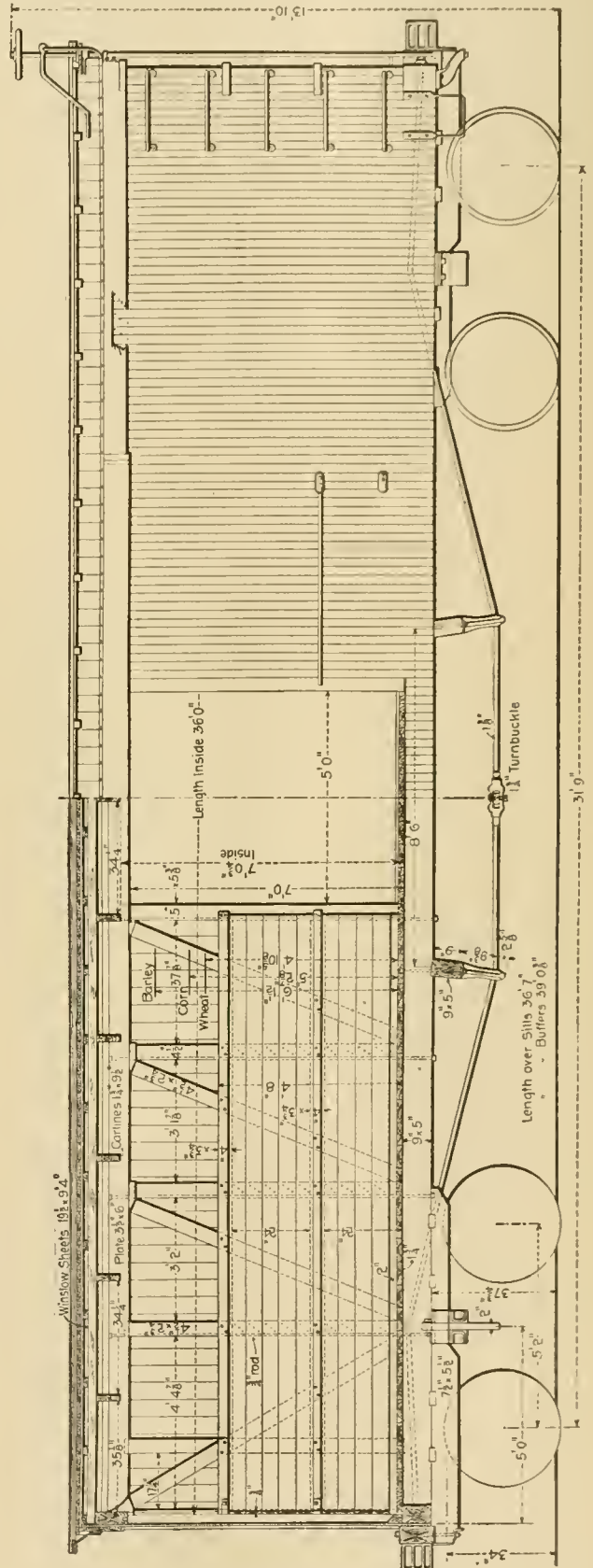

Box Car, 70,000 Lbs. Capacity—Northern Pacific Railway.

The draft rigging has double helical springs with malleable iron lugs riveted to the channels, and the outer lugs, as seen in the sectional elevation at the left, form supports for 9 by

$9\frac{3}{8}$ -inch oak blocks back of the dead blocks. The dead blocks are of cast steel.

The body of the car is of wood, the siding and ends being of $1\frac{3}{4}$ by 7 inch Georgia pine, placed inside of the posts and braces. The sloping ends are lined with $2\frac{1}{2}$ inch oak. The posts are 3 by $2\frac{1}{2}$ inch angles, weighing 6.6 pounds per foot, the plates are 4 inch channels, 8 pounds per foot and the counter braces are of $2\frac{1}{2}$ by 5 inch oak. The drop doors are of $\frac{1}{4}$ inch plate, reinforced with angles, the hinges being of cast steel bolted to the underframe. The doors are supported by $1\frac{3}{4}$ -inch crow foot rods, which secure the doors by being turned so that the crow feet extend in a direction across the car and take the weight on the rods. These rods are turned by an arrangement terminating in squared shafts at the side of the car, these being operated from either the top or the bottom of the car. The doors are closed by chains passing over a winding shaft provided with a ratchet and pawl. The ridge between the hopper doors and over the box girder is of 8 by 21 inch oak, secured by bolts and straps as shown. The cars are to be used on long, heavy grades and the Westinghouse quick acting brakes, with independent auxiliary reservoirs and brake cylinders, are used.

The trucks are of the arch-bar type with roller bearing.

hoppers down to the lower faces of the sills and by making the waste spaces at the ends as small as practicable.

BOX CAR, 70,000 POUNDS CAPACITY.

The Northern Pacific Railway has 1,000 box cars under construction, the design of which is shown by aid of the accompanying engravings. These cars are 36 feet long and of 70,000 pounds carrying capacity; they are 8 feet 10 inches wide and 13 feet 10 inches high over all. The longitudinal sills are 5 by 9 inches in section and 36 feet 7 inches long; there are six of them arranged as shown in the sectional view of the body bolster. The specifications call for either long leaf yellow pine or Washington fir, and each end is fitted with malleable iron pockets. The end sills are of oak, 6 by 9 inches, and the needle beams, draft timbers, dead blocks, auxiliary sills, posts and braces are all of white oak, and the posts and braces are fitted with malleable iron foot pockets. There are two auxiliary sills $2\frac{1}{2}$ by 9 inches between the needle beams at the doors. The girths are of white oak, $3\frac{3}{4}$ by 4 inches, the side and end plates are of $3\frac{1}{2}$ by 6 inch yellow pine. There are eleven oak carlines, $1\frac{3}{4}$ by $9\frac{1}{2}$ inches, secured to the side plates with strap bolts. The purlines are yellow pine. Tongued and grooved pine is used for the inside lining and the flooring is yellow pine. The truss rods are four in number, of $1\frac{3}{8}$ -inch iron, with

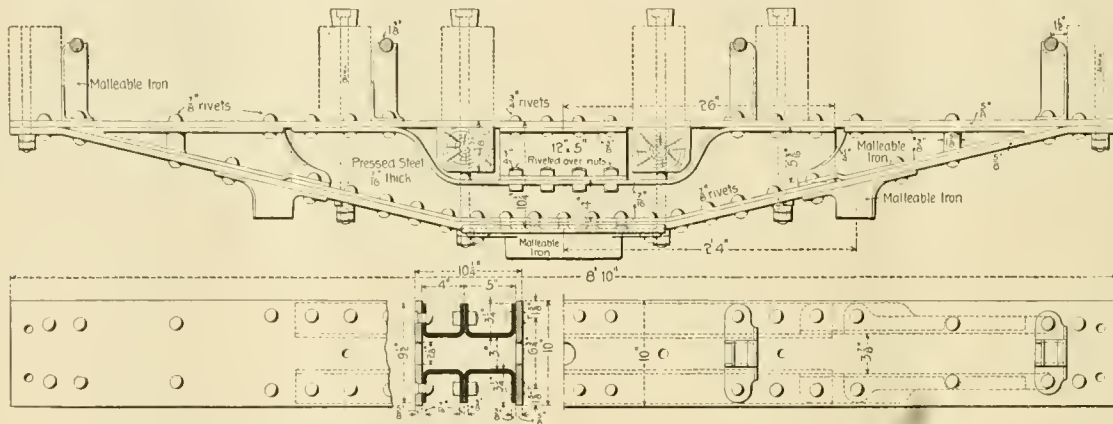

Box Car, 70,000 Lbs. Capacity—Northern Pacific Railway—Body Bolster.

swing bolsters, having three rollers of the Barber type, 2 by 14 inches in size, at each end. The bolsters are somewhat similar to the "Simplex," the tension plate being replaced by four $1\frac{5}{8}$ -inch rods, with a head on one end and nut on the other end. The compression member is a Pencoyd 15-inch 48-pound channel. The spring plank is formed of two $\frac{5}{8}$ by 4 by 6-inch angles. The springs are in groups of five, each spring being made of $1\frac{1}{8}$ -inch steel, and a block of oak is fitted between the end of the bolster and the upper roller plate, whereby the height of the car may be adjusted. The arch bars are very strong, the top one being $1\frac{1}{2}$ by 5 inches; the bottom is $1\frac{3}{8}$ by 5 inches and the pedestal tie bar is $1\frac{5}{8}$ by 5 inches. The brakes are inside the wheels and the wheels are of chilled cast iron, 33 inches diameter, weighing 750 pounds each. The axles are steel, with $5\frac{1}{2}$ by 9 inch journals and 6 feet 4 inch centers. The wheel fits are $6\frac{5}{8}$ inches diameter and the diameter at the center of the axle is $5\frac{5}{8}$ inches. The journals have collars and the axles are shown so clearly in the drawings of the truck as to render a separate engraving unnecessary. All of the cast details of the trucks are malleable iron.

In the description no pretense is made of indicating all of the details of the design, but with the aid of the drawings they will be understood. The object of this design is to produce a strong car which shall have large carrying capacity with minimum length and dead weight of train and at the same time to provide means for easily renewing such parts as are likely to become worn out in service. The large capacity, compared with other cars of this length, is obtained by carrying the

$1\frac{3}{8}$ -inch ends, the rods are tightened to give the car 1 inch camber at the center. The cars are equipped with "Chicago" roofs, 1892 pattern, with $\frac{7}{8}$ by $\frac{1}{2}$ inch pine strips between the rafters. The outside sheathing is $25/32$ -inch thick and $5\frac{1}{8}$ inches wide, tongued and grooved and double beaded on the face. The grain doors are also of the "Chicago" make, with the vertical rods rabbeted into the door posts. The cars are to be used chiefly for grain.

The couplers are the Tower, M. C. B. type, with 1 by 4 inch spring pockets; they are equipped with $1\frac{1}{2}$ by 6 by $12\frac{1}{4}$ inch followers, with two projecting bosses for double springs and the draft timbers are protected by $\frac{3}{8}$ -inch pressed steel plates fitted with malleable iron draft lugs. The draft springs are 6 by 8 inch double coil. The body bolsters are made of two $\frac{5}{8}$ by 10 inch soft steel plates, fitted with pressed steel web filling pieces shaped to fit the plates at the center and between the side bearings and with malleable iron fillers over the side bearings and at the ends. The whole structure being secured by rivets, as shown in the drawing. The center plates are of malleable iron with $\frac{3}{8}$ -inch steel liners; all of the castings except the brake wheels and pocket washers are of malleable iron. The cars have Westinghouse brakes, with retaining valves.

The trucks are of the Barber roller bearing arch bar type with Bettendorf bolsters, the axle journals being $4\frac{1}{2}$ by 8 inches, with the wheel fits $5\frac{5}{8}$ inches diameter and the center of the axle $4\frac{7}{8}$ inches diameter. The wheels are 33 inches diameter, of chilled cast iron, weighing 600 pounds each.

Of this lot of 1,000 cars, 500 are being built by the Illinois Car & Equipment Company of Chicago and 500 by the Michigan Peninsular Car Company of Detroit.

SIMPLEX TENDER TRUCK BOLSTER.—CHESAPEAKE & OHIO RAILWAY.

The tenders for the new Class G-6 consolidation freight locomotives of the Chesapeake & Ohio Railway, designed by Mr. W. S. Morris, Superintendent of Motive Power, have Simplex truck bolsters, made by the Simplex Railway Appliance Company, Fisher Building, Chicago, to the design shown in the accompanying drawing.

The tenders have metal underframes and weigh 87,000 pounds when loaded with 4,500 gallons of water and seven tons of coal, and are carried on two four-wheel trucks, with 33-inch wheels. The design of the bolster is not unlike the usual practice of the manufacturers. The 12-inch channel used for the upper or compression member weighs 35 pounds per foot, and

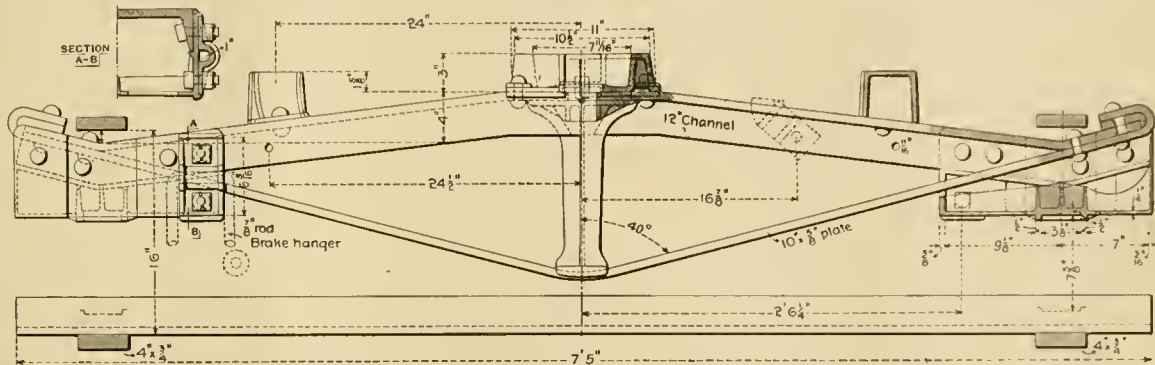

Truck Bolster for Standard Tender Truck—Chesapeake & Ohio Railway.

the tension member is a 10x5/8-inch plate. The drawing very clearly brings out the construction at the ends of the bolster, and the form is seen to be planned for the purpose of carrying the stresses upon the important members of the bolster, so as to require no service from rivets, except to hold the parts together. The bolsters are very light and a specially strong claim is made for this type of bolster for combined lightness and strength. The total number of pieces in the bolster is small, and the castings are all of malleable iron. We are indebted to Mr. Morris for the drawing.

A STEP TOWARD UNIFORMITY IN SIGNALING.

The Railway Signaling Club has undertaken a useful work in recommending methods of constructing details of interlocking signal apparatus, which, if persistently followed up, will lead to systematizing the present chaotic condition of interlocking practice. At a recent meeting of this organization a committee made a report based upon certain parts of an excellent paper presented last year by Mr. H. M. Sperry, after ascertaining the views of the members by letter ballot. The conclusions of the committee were substantially as follows:

Switches should be designed specially for interlocking work, having a lock rod at the point and a switch rod on the opposite side of the head tie, the center of the switch rod being 14 inches from the point; connection to be made by a threaded rod with jam-nuts on each side of a cage furnished with thimbles, to prevent wear to threads and allowing a play not to exceed 2 inches; the thimble to be riveted to the center of the switch or head-rod in all cases where ties can be properly tamped and adjustment is easy of access. In all other cases, as, for instance, at slips, etc., the end of switch rod should be bent down at right angles, and a rod passed through it, instead of a cage, bringing the adjustment beyond the end of the ties. Instead of the usual tang at the end of the threaded rod, an eye engaged with a screw jaw will be found very convenient for adjusting the switch when no change of throw is required, and for furnishing a jointed instead of a rigid rod (especially advantageous at slip switches). These latter devices should be used only when limited room requires their employment, as they are complicated, difficult to maintain from a trackman's standpoint and hard to protect properly with bars. For their operation we advocate rocker shafts with arms set-screwed

or pinned from the top, leaving a smooth surface on the under side, where ice usually forms, and having bearings designed to bring the shafts as near the base of rail as the length of the arms will safely permit. Only in isolated cases of single slips will cranks be found preferable. We recommend the outside facing-point lock with nearly straight lock-rod, having a screw jaw at one end connected to a lug on the front rod, this front rod in turn having a screw jaw at one end, where it catches the foot. By this means the throw of the switch can always be kept the same within small limits by varying distances between points, effecting a saving in labor of washering out the points, etc., and making all lock rods interchangeable (a marked advantage in case of wrecks).

We recommend in all new work separate levers for all signals, and that selectors be used only for slow speed routes in yards where indicators are used. We also recommend the use of bolt locks or their equivalent, placed in the connections of all high speed signals, and protecting all facing-point switches in these routes. In order to avoid complication of connections,

we suggest centering springs where facing points are beyond the tower; or, if switch levers are heavily loaded, the employment of electric locks, to be withdrawn when the switch is thrown more than three-quarters home, thus obviating the necessity of careful adjustment of the electric lock itself. An interlocking facing-point lock recently devised could be used advantageously in many places.

We recommend as a standard easily adopted by all roads a distance of 5 feet 6 inches between centers of semaphore arms, with 5-foot blades for high speed arms and 3 feet 6 inches for short arms when used; pipe connections to all home signals, and to distant signals where the run is not too long for operation; wire to dwarf signals if idle jaw is used for operating them.

Iron poles are favorably spoken of by all who use them. We would recommend that they be made of trolley pole pipe and set in cement on the lines of Mr. Elliott's design, which we believe represents the best practice. (These were illustrated in the "American Engineer," September, 1898. Editor.

Levers should be grouped in small machines with signals on the ends, switches and locks in the middle. In large machines they should be grouped as best facilitates manipulation.

Train order signals should release distant mechanically if in the same frame, electrically if otherwise. We recommend that engineers report all distant signals found against them, and rear brakemen all signals not set to protect them after passing a stated distance. Mr. Sperry advises that he has an automatic checking device for distant signals.

We recommend that all signals not plainly seen from the tower be provided with repeaters requiring only two wires; contact when closed holding arms horizontal. Any opening of the circuit due to a broken wire or an arm drooping will allow the indicator to drop to clear by gravity; it is cheap and effective, and a bell can be added if desired.

A burnished finish on the journals of axles for cars and locomotives has given good service and has been practiced on many roads for a long time. The advantage of it is to smooth the surface of the journal after the finishing cut and shorten the period of breaking in. The burnishing is done by three rollers carried on a tool rest and bearing against the journal, considerable pressure being obtained by a screw. The rest is fed along so that the finishing cut and the burnishing are done in the same time. Mr. Atkinson, of the Canadian Pacific, uses the burnisher on piston rods and intends to use it on valve rods as well as on journals. He stated at the recent Master Mechanics' convention that it gave the best finish that he knew of for piston rods.

COMMUNICATIONS.

GRATE AREAS, HEATING SURFACES AND CYLINDER VOLUMES.

Editor "American Engineer":

Referring to the matter of proportions for locomotives burning bituminous coal, as suggested in the communication by "C. G. O." on page 260 of your August, 1898, issue, and in view of a recent discussion in the Northwest Railway Club upon heating and grate surfaces, I desire to record that my experience leads me to adopt for bituminous coal burning engines the following figures: For road engines 2.4 square feet of grate surface to a cubic foot of cylinder volume; for switch engines, 2 feet; for heating surfaces in both road and switch engines, 80 square feet to 1 square foot of grate area.

All soft coal burning engines should have a deflector, either in the form of a water leg or brick arch with deep fire boxes or an upright wall in the shallow ones. The upright wall may be partially perforated with good results. An air supply above the fire, amounting with most bituminous coals to 1-50th of the grate surface, is necessary for economical work. The only requirements in regard to this air supply are that it shall be near the line of fire, be composed of comparatively small openings and without direct communication to the tubes.

These proportions are closely reached in a great many modern engines, but there is great want of uniformity yet, and many roads are using much more coal than is necessary on account of imperfect construction. With the shallow box it is advantageous to make a fire box considerably larger than is needed, the space not needed for grates being bricked over and, in connection with a vertical wall, forming a flame way and combustion chamber.

Another need that we expect to have filled in the near future is a better form of tube for effecting a more complete absorption of the heat from the burning gases into the water. The difficulty with patterns now in the market is their high cost, but I feel that this will be remedied sooner or later.

C. M. HIGGINSON,

Assistant to the President.

A., T. & S. Fe Ry., Chicago, September 17, 1898.

[Mr. Higginson has advocated ample heating surfaces for a long time, and has urged more attention to the admission of air and to giving flame way enough to produce complete combustion. The article by Mr. M. N. Forney on another page of this issue is commended to the reader in this connection. There is no more important subject in locomotive design than proportions affecting combustion. There is much to think about in these suggestions, and we shall be glad to have the opinions of other readers.—Editor.]

SIDE BEARINGS FOR CARS.

Editor "American Engineer."

I was considerably interested in reading the editorial in the September issue of the "American Engineer" on the subject of side bearings for cars.

The advent of heavy cars of 80,000 and 100,000 lbs. capacity has brought one great blessing at least. It has forcibly called attention to the fact that it is absolutely necessary for safety and efficiency to relieve the flanges of the wheels from the great strain, and consequent friction and wear upon them, caused by cars carrying the loads almost as much upon the solid side bearings as upon the center plates. From time to time in the past, attention has been called to the necessity of having the trucks swivel freely, but the subject has at no time been so generally under consideration as at present.

In the past in the designing of cars on most roads, the space between the top of the truck bolster and bottom of the car sills has been so small that it was practically impossible, without increasing it, to get sufficient depth for a body bolster to successfully carry loaded cars of from 60,000 to 100,000 lbs. capacity and support the load on the center plates. Most of the recent cars of 80,000 and 100,000 lbs. capacity have been constructed with steel under-framing, and in the case of coal and ore cars have a steel superstructure. The whole design of these cars has been on entirely new lines, and instead of being confined to a limited distance below the sills for the body bolster, it has been possible to make the bolster with no

limit to depth, except what was required to make it carry the side sills of the car with their proportion of the load, with absolutely no appreciable deflection. With such a strong body bolster it was found that the side bearings kept apart and the load was, as far as possible, carried on the center plates. Of course, trains of cars so equipped were found to haul much easier; and there was an absence of squeaking of wheels when passing around sharp curves. Manufacturers of steel cars called attention to this good feature of their construction and design, and as a result considerable investigation has been made as to the condition of bolsters and side bearings on older cars, with wooden framing. The investigation has shown that almost nine out of ten of the older cars, on most of our roads, are running with side bearings in contact, even when the cars are empty; undoubtedly when loaded a large percentage of the load is carried by the side bearings. It is in most cases impracticable to apply new and sufficiently stiff body bolsters to our older cars so that they would ride with the load carried entirely on the center plate, for the application of such body bolsters would necessarily raise the cars beyond the standard height for the center of the drawbar. The only thing that seems practicable for relieving the side bearing friction on such cars is to apply some form of frictionless side bearing. This has been done very satisfactorily on several roads in the country, where they have had to deal with many sharp curves. The result of the anti-friction side bearings on flange wear has been very marked, the service of the wheels being greatly extended.

In new designs for cars, where it is possible to have distances which will allow the construction of an amply stiff body bolster so that the load can be carried on the center, such a result should be sought for; but it is well known that the loading of cars is not always adjusted and balanced so that the cars will ride on the center. Many times, especially with coal and ore, the load on one side of the car is considerably more than on the other. As a result, such cars, in spite of being center bearing cars, will ride constantly on the side bearings on one side, producing the resultant friction and flange wear. It is also true that in going around curves at speed, the centrifugal force will throw the load quite largely on the outer side bearing. Such being the case, there seem to be very strong and reasonable arguments for the application of frictionless side bearings on cars of future design, even though it may be possible to keep the side bearings apart, with the load on center plates, under normal conditions.

It is very necessary, if in time the body bolsters or the truck bolsters become so settled or distorted as to allow the side bearings to come in contact under heavy load, to have as nearly as possible a frictionless contact at the side bearings.

Some months ago, the subject of carrying load on center plates or on side bearings was discussed before the Western Railway Club. I took the ground, as the result of examination that I had recently made of some old cars, that it was a reasonable conclusion, provided side bearings could be made anti-friction, that the ideal way of transmitting the load, considering the service of the truck bolster as well as freedom of swivelling in the truck, would be to have the load divided between the side bearings and the center plates. My reason for taking that ground was, as I stated at the time, that it would not do to carry the load on the ordinary center plate and then have the common cast iron or malleable iron side bearings in contact. I stated that I believed it was worthy of consideration, in designing heavy capacity cars, to consider the advisability of applying some device so that the bolsters would carry the load distributed between the side bearings and center plate. I have given the subject considerable consideration, and am convinced that it will not do to depend, in the very heavy capacity cars, upon carrying the load of the car entirely on the center plate, without providing means for freedom from excessive friction, when the load is so adjusted that the cars will settle down on the side bearings on one side. Hence my conclusion is that:

The design of bolster should be of such a character as to carry the load on the center plate, with the side bearings in normal condition a short distance apart, possibly $\frac{3}{8}$ inch or $\frac{1}{2}$ inch, then provide anti-friction side bearings of some kind so that in rounding curves, or when the load is unevenly distributed, the trucks will be free to swivel and adjust themselves to the track without excessive flange friction and wear.

Fortunately during the past year, body bolsters have been

developed which may be safely depended upon in carrying the heavy loads now placed in cars, without the bolsters showing any excessive deflection which would bring the side bearings in contact if they were originally $\frac{3}{8}$ inches or $\frac{1}{2}$ inch apart. Prior to last year, very few, if any, bolsters have been designed which would permanently carry the loaded cars on which they were supported without the side bearings eventually coming in contact.

A. M. WAITT,

General Master Car Builder.

Lake Shore & Michigan Southern Ry., Cleveland, Sept. 13, 1898.

THE SUSEMIHL-TORREY CAR SIDE BEARING.

Of late we have given considerable prominence to the subject of side bearings for cars, which is important on account of the increasing weight and capacities of rolling stock. Many attempts to use roller bearings have failed on account of the tendency of rollers to become flat, resulting in a somewhat worse condition than obtained with ordinary bearings. If

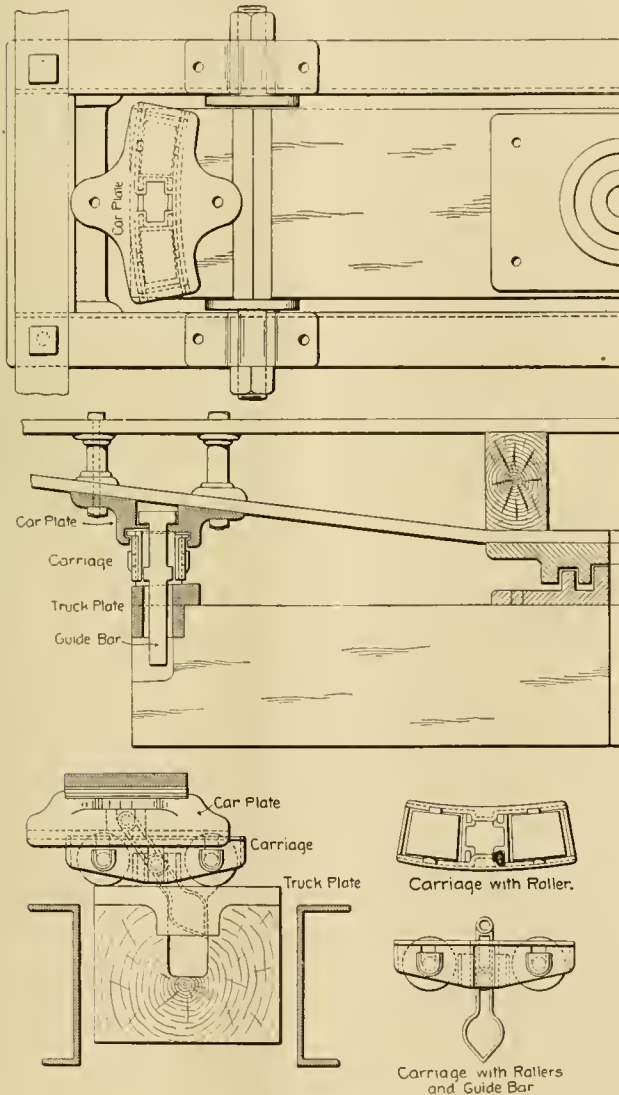

The Susemihl-Torrey Side Bearing.

roller bearings are so constructed as to compel the rotation of the rollers with every movement of the bolsters, one of the objections to their use will be overcome, and through the courtesy of Mr. Robert Miller, Superintendent of Motive Power and Equipment of the Michigan Central Railroad, we illustrate the Susemihl-Torrey side bearing, now in successful use under all of the passenger cars on that road. In this design the construction is such as to give a positive movement of the rollers, compelling them to roll when the car strikes curves. The increased effort required to pull cars with the trucks cramped is very expensive,

as has been shown by Mr. A. E. Mitchell (See American Engineer, July, 1898, page 229), and the subject is worthy of much more attention than it has received.

Our engraving shows the construction of the bearing, with which some of our readers are doubtless familiar. There are two bearing plates: one fastened to the transom of the car, the other to the bolster of the truck. Interposed between these lies a carriage confining two cone-shaped rollers. The rollers are cone-shaped to conform with the center of motion, to avoid twisting and sliding of the rollers. The bearing surfaces have a hollow cone-shaped form for making the movement of the rollers perfect. The carriage has flanges on top which engage in grooves of the top casting.

The main feature of the device is a bar which is pivoted in the top casting and engages with a center pivot in a slot formed in the carriage, and rests with a third pivot in the bottom part of the bottom casting. The center pivot is an equal distance from the centers of both end pivots. While the top casting with the car moves away from the original position in relation to the bottom casting in the truck, the pivot bar travels upward in the box of the bottom casting, and the center pivot travels upward in the slot of the carriage, thereby controlling the position of the carriage and holding it always in the middle between the top and bottom casting on any curve. Without this pivot bar the carriage and rollers might gradually become displaced, but any tendency toward displacement is counter-acted by the pivot bar. When the top casting is bolted to the transom of the car, the carriage rollers and pivot bar stay with the top casting. In jacking up a car for repairs no difficulty arises; the bottom casting being bolted to the bolster of the truck stays with the truck, the pivot bar draws out of the box opening of the bottom casting, and all the parts are lifted up with the car. When the car is lowered, the pivot bar being pointed at the bottom inserts itself into the box of bottom casting and the rollers find their proper position on the bearing plates. The rollers are common chilled castings. Both bearing plates have chilled surfaces and are also common castings. The carriage is made of malleable iron. The pivot arm is either malleable or forged. This bearing may be used on most passenger cars and under certain classes of freight cars, where sufficient space is given between the transom of the car and the bolster of the truck or where the bolster may be cut away for the bottom end of the pivot bar; or with such freight trucks as have no bolsters. A new patent has just been granted to the same gentlemen for a slide-bearing which may be used under all cars, even if the space between the bolster and transom is only five inches. According to that patent the guiding bar is made in two parts, one pivoted to the top casting and one pivoted to the bottom casting, both guide bars passing through a swivel bar pivoted in the carriage.

THE SHANSI COAL MINES—CHINA.

Advance sheets of consular reports giving details of the concessions made by the Tsung-li-Yamen of China to the Peking syndicate of London, have been received. Of the extent and value of the deposits to be worked, Consul Ragsdale says:

"In the eastern portion of the province, and running into the province of Honan, are deposits of anthracite coal. The western half has bituminous coal covering some 12,000 square miles, and all along the western boundary are deposits of petroleum. At many different points in the coal region are deposits of rich iron ore. The coal strata are practically horizontal and at an elevation of about 2,500 feet. They show wherever erosion has cut to a sufficient depth. This anthracite coal vein is unbroken over an area of 13,500 square miles, and its thickness varies from 25 to 50 feet, an average of 40 feet. All of this deposit is within the limits of the concession.

"There are thousands of native coal mines now in operation, and the coal has been used for probably 3,000 years. The iron ore is now worked by the natives. This entire region has been examined by William H. Stockley, mining engineer, and Charles D. Jameson, Civil Engineer, both Americans, and in the employ of the syndicate. There is probably no coal field known in the world that can compare with this of Shansi, either in quality or quantity of coal or the possibility of cheap production."

(Established 1832)

AMERICAN ENGINEER

CAR BUILDER AND RAILROAD JOURNAL.

29TH YEAR.

67TH YEAR.

PUBLISHED MONTHLY

BY

R. M. VAN ARSDALE,

MORSE BUILDING.....NEW YORK

G. M. BASFORD, Editor.

OCTOBER, 1898.

Subscription.—\$2.00 a year for the United States and Canada; \$2.50 a year to Foreign Countries embraced in the Universal Postal Union. Subscriptions for this paper will be received and copies kept for sale by the Post Office News Co., 217 Dearborn Street, Chicago, Ill.

EDITORIAL ANNOUNCEMENTS.

Advertisements.—Nothing will be inserted in this journal for pay, EXCEPT IN THE ADVERTISING PAGES. The reading pages will contain only such matter as we consider of interest to our readers.

Special Notice.—As the AMERICAN ENGINEER, CAR BUILDER AND RAILROAD JOURNAL is printed and ready for mailing on the last day of the month, correspondence, advertisements, etc., intended for insertion must be received not later than the 20th day of each month.

Contributions.—Articles relating to railway rolling stock construction and management and kindred topics, by those who are practically acquainted with these subjects, are specially desired. Also early notices of official changes, and additions of new equipment for the road or the shop, by purchase or construction.

To Subscribers.—The AMERICAN ENGINEER, CAR BUILDER AND RAILROAD JOURNAL is mailed regularly to every subscriber each month. Any subscriber who fails to receive his paper ought at once to notify the postmaster at the office of delivery, and in case the paper is not then obtained this office should be notified, so that the missing paper may be supplied. When a subscriber changes his address he ought to notify this office at once, so that the paper may be sent to the proper destination.

The paper may be obtained and subscriptions for it sent to the following agencies: Chicago, Post Office News Co., 217 Dearborn Street. London, Eng., Sampson Low, Marston & Co., Limited St. Dunstan's House, Fetter Lane, E. C.

Side bearings vs. center plates, or the manner of carrying the load from body bolsters to truck bolsters of cars was discussed briefly last month, and in this number there are two contributions to the subject, one from Mr. A. M. Waitt, of the Lake Shore & Michigan Southern, and the other describing the side bearing that is advocated and extensively used by Mr. Robert Miller, of the Michigan Central. Mr. Waitt takes the view that "frictionless" side bearings ought to be used anyway, whether the bolsters are stiff enough to carry the load without undue deflection or not. His position is a reasonable one, because side bearings must sometimes be in contact, and when they are touching there is need of an easily moved contact. The loading of the car may be irregular, with more weight on one side than on the other, curves will cause the bearings on one side to come together owing to centrifugal force, and in time distortion may give a permanent contact, even if the original strength of the bolsters is ample. Arguing from these premises, good side bearings that will not stick or rub hard, are desirable, even with stiff bolsters. From the other article on side bearings it may be inferred that Mr. Miller's experience with the Susemihl-Torrey side bearing is good ground for believing that the principles used in its construction are correct.

It is probably an idea of economizing that prompts some railroads to manufacture pistons and other parts of air brake triple valves for their own repair work, but there can be no doubt that this is a mistake. The air brake manufacturers have learned at enormous expense that the triple valve is a delicate piece of mechanism that justifies any amount of cost for special machinery and perfection of workmanship. Those who have seen these valves made are convinced that they cannot be replaced in an ordinary shop, and it is evident that even slight variations from the standard work that must exist in these homemade parts may in time prove to be a serious source of annoyance and expense.

Track tanks for supplying locomotives with water while running have been in high favor, chiefly because of the saving in time which their use made possible. Opinion is rapidly changing, however, and their abandonment by the Maine Central is a sign of this. They do not pay under the conditions of operation which now generally obtain in this country. The tanks are expensive to build and to maintain, the water must be prevented from freezing in cold weather, and it is difficult at all times to keep it free from cinders and dirt; the tender attachments also cost a great deal, and altogether the elevated tanks appear to be preferred for all cases, except those requiring long runs without intermediate stops. The water column system on most railroads needs revision, however, and it is likely to be made a subject of general improvement. This has already been inaugurated on several Western roads by the use of tanks elevated enough to give a good head of water and the employment of large pipes and stand-pipes or water columns. Eight-inch pipes, or smaller, should be discarded as soon as possible and replaced with larger ones, say 12 inches in diameter, through which a 4,000-gallon tender tank may be filled in less than one minute. When the pipes are small, delays occur and more coal must be burned to keep trains on time. This is a strong argument for the large pipes, and even if they cost more than small ones, the money will be returned many fold. Some of the best roads have not yet taken this subject up in earnest, but they probably will do so when they come to appreciate the advantages. Station delays are very expensive, and they grow more so with the increasing number of fast schedules.

THE BREAKAGE OF PISTON RODS.

In our issue of last month we printed an abstract of a paper by Mr. J. E. Johnson, Jr., on the subject of the carbon contents of piston rods for locomotives, which recorded the experience of the author in the use of steel and Swedish iron in piston rods on a compound locomotive of the Vaucrain type. The rocking of crossheads of locomotives often causes rather severe bending stresses in the piston rods, which has been the source of trouble in breakage of the rods. The first rods used in the engine dealt with in the paper were of steel, and after breaking they were replaced with new rods of machinery steel, with very unsatisfactory results. These were in turn replaced with Swedish iron, giving the shortest life of all. Nickel steel was then tried, and up to the time of writing the paper this material had lasted two and a half times as long as the Swedish iron.

Presuming that the conditions of service, except as to the material used in the rods, were unchanged during this time this experience shows conclusively that steel is better than iron for such severe work. It would be valuable to know the relative tensile strengths and the limits of elasticity of these different materials, but the author of the paper does not tell us. It may, however, be assumed that the elastic limit of the nickel steel was far above that of the others, and herein is an element of great importance in all cases where repeated stresses occur. The ideal material for such service is one having sufficient hardness and at the same time enough ductility,

and steel having a very high elastic limit without a correspondingly high tensile strength would probably be the most favorable for this purpose.

An important question of design that should not be lost sight of here is the turning down of the parts to prevent the localization of the bending stresses near the ends of the rods. Professor Sweet has suggested that piston rods be made stronger by being made weaker, transversely. If these rods were made smaller at the crosshead ends by turning them down, for as much of their length as space would allow, and making the corners well rounded to give large fillets, the bending due to the rocking of the crossheads would be distributed over a larger part of the rod, which could not fail to be an advantage. This principle has been very successfully carried out in the construction of very high speed marine engines where great difficulty has been experienced with breakage from similar causes, the best example being in the practice of changing the sections of connecting rods at the crank pin ends from a circular to an elongated one, with the longer dimension parallel to the axis of the crank pin. This is done by Mr. C. D. Mosher, in his famous high speed steam yachts. We believe that the same idea might be carried out to a sufficient extent in locomotive work. That weakening the rods will make them last longer appears paradoxical, but the proposition is a reasonable one.

THE DUMMY COUPLING.

The present dummy coupling is not to be defended, but when a device is badly needed and a perfectly satisfactory one is not immediately available, it would seem to be a wise and good business policy to get along with an imperfect one while seeking for a satisfactory solution of the difficulty, instead of discarding that which, while defective, does its work partially. This was done by the Master Car Builders' Association recently in cutting the dummy coupling out of the list of recommended practices of the Association. We do not believe this to be a good way to treat the subject. It would be better at least to accompany this action by provisions for replacing the present dummy with something better, since it is generally admitted that there is a great need for a device to do what the dummy was planned and yet failed to do, and which at the same time will avoid the serious faults of that device.

The prime object of the dummy was to keep dirt out of the end of the hose when not coupled up, and the present device not only fails to do this on account of imperfect closure of the end of the hose, but it is, as generally applied, actually detrimental on account of kinking the hose, causing early failure of the rubber. A device that would keep the dust out and also permit of hanging the hose up without kinking is worth considerable trouble to get, and we believe that this result will be attained and that the Association will take up with the dummy again. If a committee had been appointed at Saratoga and instructed to investigate and report on a proper substitute for the faulty dummy they would at once discover the existence of a new one that apparently has all the qualifications of success.

The air brake has become too important to neglect, and when dirty triple valves are worrying so many motive power officers it is strange that there is anything like apathy in the attitude on this question, especially because its solution is not to be classed among the difficult ones. A coupling that is designed to be tight and then is well made so as to exclude dust is not a difficult thing to produce, and it need not be expensive to make and maintain. This will dispose of the introduction of dust and dirt into the air brake pipe, and by the use of a short piece of chain, which will permit the hose to hang in a natural curve and avoid the kinking that has been the cause of disintegration of so much hose, the other objection to the present device will be removed.

A good thing for immediate application is the short piece

of chain attached to the present dummy. Then if the rule requiring hose to be hung up when not in use is enforced, the next logical step, a better dummy, is in order.

An air brake inspector in a recent experience trip visited one of the roads that has discarded the dummy, and in examining the condition of triple valves removed from service found many of them in very bad shape from foreign matter after from ten to twelve months' service, but strange to say they all worked. The road removes freight triples from the cars after about a year's service and sends them to the shop to be cleaned, and while the valves ought to be overhauled as often as that on general principles, the larger portion of this plethora of dirt should be kept out.

The action on the dummy coupling has been spoken of as "very hasty," and we are inclined to think that there are many members of the Association who would like to see it disposed of in a different way.

THE ATLANTIC CITY FLYER—PHILADELPHIA & READING RAILWAY.

Train No. 25 on the Philadelphia & Reading, which ran from Philadelphia and Atlantic City during the months of July and August of last year, ran also during the same months this year, and the wonderful record of its speed and punctuality, recorded for last year on page 426 of our issue of December, 1897, has been practically equaled this year, and the train has justly earned the title of the fastest train in the world.

The Baldwin Locomotive Works built several new engines this year with a view of increasing the speed of the train or making its punctuality more certain, and the results have been perfectly satisfactory. The editor of this journal enjoyed the privilege of a ride on the engine that hauled the train August 23. It was a most interesting and instructive trip. The engine, the track, the train and the manner of handling the train in every particular were noteworthy. The time was taken at the mile posts and the fastest mile was made in 42¾ seconds, at the rate of 84.21 miles per hour. The conditions of the run were normal in every respect, and therefore the record here given may be taken to show the regular working of the train rather than an extra fast trip. The time for the whole trip of 55.5 miles was 47½ minutes, or a rate of 70.08 miles per hour for the entire run from start to finish. We are told that the fastest trip of the season was made in 44¾ minutes, or at the rate of 75.3 miles per hour, and the regular schedule time is 50 minutes, or 66.6 miles per hour.

The engine, No. 1,028, is of the Atlantic type, like No. 1,027 that hauled the train last year, except that the valves are 12 inches in diameter, one inch larger, and while the schedule is the same as last year the train has one more car on Saturday of each week and no difference seemed to be made in the running. The weight of the train on the day of record was: One combination car, 57,200 pounds; four coaches, each 59,200 pounds, and a Pullman car, weighing 85,500 pounds, a total, including the weight of the engine, 227,000 pounds, of 606,500 pounds.

The engine had 84½-inch drivers and in other respects the dimensions are as given in our article of last December. Its riding qualities were such that the writer had no difficulty to read stop watches without standing up, and this is enough to show that the engine rides well. Naturally the timing required a great deal of attention, but such observations as could be made of the running of the engine were revelations. The success of the train is due very largely to the enginemen. Mr. Charles H. Fahl was the runner and Mr. John T. Pettit the fireman. The coal was known as "Tunnel Ridge" anthracite, a good quality, and the steam pressure did not vary but 3 pounds from a pressure of 205 pounds during the entire trip. The throttle was opened but little and it was not changed during the run, and but one change was made in the boiler feeding, the right hand injector was used on the first half of

the trip, and then the other was substituted for it. The cut-off was as short as it could be made with the notches given, and we are told that it was 10 inches in the high pressure cylinder. The water evaporated averaged about 54 pounds per mile, and approximately two tons of coal were burned.

There were no hot journals about the engine at the end of the run, and it will not be surprising to be told that the engineer selected for this train has had a long, good record, and especially in regard to fuel economy. The engine steamed freely and the fireman, while very attentive to the fire, did not work as hard as many do on comparatively easy runs. The grate area is 86 square feet. The power of the engine is abundant for this work and we think its limit was not nearly reached in the trip recorded.

The timing of the train is given below, the train sheet times having been copied from the train dispatcher's sheet.

Timing of Atlantic City Flyer August 23, 1898.
Left Camden 3.50¼ p. m.

Mile Post.	Time.	Mile Post.	Time.
55.....	1.36½	27.....	.44
54.....	1.22½	26.....	.44½
53.....	1.03	25.....	.45
52.....	.59	24.....	.45
51.....	.59½	23.....	.44
50.....	.58½	22.....	.46
49.....	.54½	21.....	.45¾
48.....	.53¾	20.....	.44¾
47.....	.49½	19.....	.45
46.....	.50¾	18.....	.42¾
45.....	.49	17.....	.44
44.....	.46¼	16.....	.45¾
43.....	.47	15.....	.45¾
42.....	.50½	14.....	.45
41.....	.52½	13.....	.46
40.....	.53¼	12.....	.46¼
39.....	(Missed mile post)	11.....	.46¾
38.....	1.41½	10.....	.44¼
37.....	.48	9.....	.44½
36.....	.45	8.....	.45
35.....	.46½	7.....	.46½
34.....	.45½	6.....	.46¼
33.....	.48	5.....	.44¼
32.....	.44	4.....	.46½
31.....	.45	3.....	.50½
20.....	(Missed mile post)	2.....	.53½
29.....	1.31¼	1.....	(Drawbridge) 1.11
28.....	.45¾	Atlantic City.....	(Stop) 1.46

Arrived in Atlantic City 4.37¾ p. m.

Train Sheet Record.

	Miles.	Time.
Camden.....	3.50¼
West Collingswood.....	3.10	3.55¾
Haddon Heights.....	5.5	3.58
Magnolia.....	7.9	4.00
Clementon.....	12	4.03¼
Williamstown Junction.....	17	4.07¾
Cedar Brook.....	19.9	4.09½
Winslow Junction.....	24.5	4.12¾
Hammonton.....	27.6	4.15½
Elwood.....	33.8	4.20¼
Egg Harbor.....	38.7	4.24¼
Brigantine Junction.....	43.5	4.27¾
Pleasantville.....	50.5	4.33
Meadow Tower.....	53.8	4.35
Atlantic City Depot.....	55.5	4.37¾

Time for trip from start to stop, 47¼ minutes.
Average speed for trip in miles per hour, 70.08.
Fastest mile in 42¾ seconds, or 84.21 miles per hour.

NOTES.

Tests on six-inch Krupp armor plate, made by Carnegie, at Indian Head, show that these plates 10 and 11 inches thick will be equal to 15 and 18 inches of Harveyized plates, such as are carried by the "Oregon."

The improvement in train service in England is shown by the fact that in 1884 there were but seven trains making runs of 100 miles or more without intermediate stops. In 1896 it had grown to 58, and the present year it has reached 78. A complete list of these trains with their speeds was recently published in "Engineering."

The 6-inch breech-loading guns of the battleship "Oregon," of which she has four, have been replaced with rapid fire guns and her funnels have been lengthened 10 feet to improve the running under natural draught. The old slow fire 6-in. guns on the "Massachusetts" are also changed for rapid firers and her funnels have also been lengthened.

The Navy Department has decided to award bids for the purchase of 1,000,000 pounds of smokeless powder, proposals for which were opened during the first week of September. The Duponts, of Wilmington, and the California Powder Company will secure the contracts, the prices being 90 cents per pound, which is less than the prices that have been paid by the army.

Aluminum conductors are used for the first time in long-distance electric transmission in carrying the current from the Snoqualmie power plant to Tacoma and Seattle. The line to Tacoma is 47 miles long, and Seattle is reached by a 12-mile branch. The wires are Nos. 2 and 3 B. & S., the composition being aluminum 99.3 per cent., iron 0.25 per cent., silver 0.3 per cent., and this metal alloyed with 1.5 per cent. of Lake copper.

The speed of several trains on the London & Northwestern has been increased in the summer time table now in force. There are two trains between London and Liverpool, 201 miles, running at a speed of 51.8 miles per hour; five trains between London and Crewe, 158 miles, at 51.6 miles per hour; two trains between Carlisle and Crewe, 141 miles, at 52.9 miles; two from Wigan to Carlisle, at 52.6, and two from Willesden to Sheffield at 52.2 miles.

The effect of vestibules in reducing the damage to cars in wrecks was strikingly illustrated by a rear end collision on the Lake Shore August 17, in which the "limited" ran into six ice cars that were left standing on the main track near La Porte, Ind. The cars of the passenger train had wide vestibules, with the exception of the front end of the buffet car, next to the engine, and this was the only platform injured. None of the other cars was injured and no one was killed, which must be credited to the vestibules.

The proceedings of the street railway convention held in Boston, and also the character of its exhibits, seem to indicate a general tendency toward systematizing the power equipment of cars. Convertible cars attracted more than usual attention and two forms were exhibited. The "maximum traction truck" with two axles, and two trucks per car, appeared to enjoy general favor. This truck has two large and two small wheels with the load so distributed as to bring the maximum amount of weight upon the wheels that are used as drivers. Double truck cars have undoubtedly increased in favor since last year.

The report of the Commissioner of Patents for the year ending Dec. 31, 1897, records the customary increase in number of patents taken out, and in fact throughout the history of the patent office the number filed in any one year has never fallen materially below the number filed in any previous year. The number filed in 1897 exceeded by over 2,000 the total number filed in 24 years, from 1836 to 1860. The total for 1897 was 21,508, the largest numbers being by citizens of New York, Pennsylvania, Illinois and Massachusetts, in the order named. Patents granted to foreigners numbered 2,221.

Boston's subway, which was built for a little less than its estimated cost of \$5,000,000, has been finished and thrown open to the use of the public. The work was begun a little less than 3½ years ago, and in its completed state comprises 12-3 miles of tunnel, with 5 miles of railroad track, and in furnishing the means for underground electric transit relieves a congestion in street traffic that was a great nuisance. The subway is the first underground electric road in this country, and its operation will be watched with keen interest. The commission that had charge of the improvement has made plans for a tunnel to East Boston, and has plans for several routes from which a selection is to be made.

The unarmored cruiser "Chicago," launched in 1884, has been undergoing changes at the Brooklyn Navy Yard intended to convert her into a fast cruiser of 18½ knots, developing about 9,000 indicated horse power. On her trial trip she made but 15 knots with 5,083 horse power. She is being provided with new engines and new boilers. There are to be four Scotch boilers of nickel steel, of 10½ feet in length and 13 feet 8½ inches diameter. There will also be six Babcock & Wilcox water tube boilers. Steam pressure of 180 pounds will be used. The bunker capacity is 920 tons. The ship will also be provided with the Cowles system of bulkhead doors.

The transition from day work to piece work is a critical period in most ships, and the success of piece work depends upon the manner of making the change. Mr. W. S. Rogers, in a paper before the New York Railroad Club, gives the following suggestions: "The simplest and easiest method of obtaining prices for the purposes of establishing permanent piece work rates in a shop or factory of any kind, and a practically correct cost system, is to adopt a premium method with the workmen for a few months, allowing them a fair percentage of their hour rates for the number of hours saved on their labor. When this has been carried far enough, in the judgment of those in charge, it can be abolished and piece prices put into use without any trouble whatever."

The promotion of naval officers in the form of advancement by several numbers as a reward for specially meritorious service during the war would work an indirect hardship on those who perhaps are equally worthy, but were not fortunate enough to have an opportunity to show what they could do, and it would practically degrade these men to advance the others under present rules. It would make their advance slower and in some cases prevent them from attaining their rightful grade at time of retirement. It is understood that steps will be taken to correct this injustice by legislation which will accomplish the proper promotion of those who have not had the special opportunities to distinguish themselves, and the Secretary of the Navy has already arranged to introduce a bill with this object in view.

The programme of the naval construction board, based upon recent developments, includes fifteen new warships, divided into three battleships, three armored cruisers, six protected cruisers of small size and three ships of medium size and protection. The tonnage of the battleships is to be 13,500, with a draft of 25½ feet; the minimum speed, with all stores and fuel, to be 18½ knots. The armored cruisers will have a displacement of 12,000 tons, a speed of 22 knots, and steaming radius of 10,000 knots. The armor for the battleships will be extended all over the ships; it will be 12 inches amidships, tapering to 5 inches at the ends, and made by the Harvey Krupp process. These ships will have four very long 12-inch guns in elliptical balanced sloping turrets. The whole list of ships will have water tube boilers.

In regard to the competition of electric lines, President Tuttle, of the Boston & Maine, believes that the steam roads will have to bow to the inevitable and surrender a portion of their suburban traffic. No matter, he says, how the matter may be viewed, the street railway within certain limits has now and will continue to have the advantage over the steam roads. The latter may improve their service as much as they can, but they will find eventually that they cannot compete with the trolley lines, which insure service that the steam roads cannot give, and the latter will therefore have to abandon suburban business within four or five miles of the city. They will have to develop their long-distance service, and can make improvements within a zone of from six to twenty-five miles, in addition to lowering the longer distance rates. In this way suburbs will be extended. With such an expansion and attention to through freight and passenger business the steam roads will still have an ample and profitable field of operation.

The new course in naval architecture begun last year at Annapolis under Constructor Hobson has, upon the advice of Chief Constructor Hichborn, been transferred to the Massachusetts Institute of Technology. The purpose of the change appears to be to offer the cadets the advantages that come from a complete course under a number of instructors rather than one taught by a single individual. It is a post-graduate course, and is intended to take the place of the former plan of sending the cadets abroad to the leading foreign technical schools. The final arrangements are to be made by Captain Dickens and Constructor Bowles. The course is thorough and practical, and the intention is to afford facilities second to none existing in Europe, not excepting Great Britain. The first class will have eight students, who begin work Oct. 1 for three years' training, which includes practical instruction at the shipyards and navy yards during the summer. A national distinction that is well deserved is given to this school by its selection, because the decision was made upon the recommendation of Constructor Hichborn after an examination of the facilities offered by the best schools of the country.

The engineers of the fleet that sunk Cervera's ships off Santiago were tendered a complimentary dinner by the Engineers' Club of New York, September 1, and during the evening Chief Engineer Milligan, of the "Oregon," related the experiences of the famous run by that ship around the "Horn." He paid the highest tribute to the devotion and courage of the firemen and assistant engineers, giving them the credit for the success. He spoke highly of the workmanship of the engines and boilers of the "Oregon," and the fact that no salt water leaked through the condensers and got into the boilers, showed the high grade of work done by the builders. When at Rio a dispatch told them of the departure of Cervera's fleet from the Cape Verde Islands and Mr. Milligan told of the plan that was at once arranged in the event of meeting the fleet. The "Oregon" was to start as if to run away and her high speed would string out the Spanish vessels in the order of their speed, whereupon the "Oregon" was to attack the foremost and attempt to destroy them one at a time. It was a shrewd plan and in the light of subsequent events the chances that it would succeed are very strong. The engineers earned the reception and we think that justice has not yet been done them for their important work in the war.

The percentage of hits from the gun fire of our fleet at Santiago tells better than anything else the relative values of the different guns as regards calibers and rapidity of fire. The proportion of projectiles that found their marks was only about 3 per cent., and in view of the good marksmanship this must be considered as the best that is to be expected under the severely trying conditions of naval fighting. It is made clear that rapidity of fire is vitally important. In estimating the results with reference to the small amount of damage done by the large guns, it must be remembered that the conditions did not favor the use of this armament, and that when opposed by heavily-armored vessels the high power guns are absolutely necessary. The lesson here is that every effort should be made to increase the rapidity of their fire as well as that of the smaller guns. The official report to the Navy Department analyses the hits from the guns of the United States fleet and gives the proportion of hits for each size of gun on each of the Spanish cruisers, as follows:

Size of gun.	Number of hits on each vessel.				Total number of hits by each caliber of gun.	Number of guns of each caliber in action	Number of hits per gun.
	Teresa.	Oquendo.	Vizcaya.	C. Colon.			
6-pounder	17	43	13	4	77	42	1.83
1-pounder	2	2	13	0.15
4-inch	1	7	4	..	12	3	4.00
5-inch	3	3	7	2	15	6	2.50
6-inch	1	1	..	1	3	7	0.43
8-inch	3	3	5	1	12	18	0.67
12-inch	2	2	6	0.33
13-inch	5	0.00
Totals...	29	57	29	8	123	103	..

SUPERHEATER FOR LOCOMOTIVES—A SUGGESTION.

We refer to this superheater in the above caption as "A Suggestion" because we consider it such, and it is interesting in showing how a foreign engineer has worked out the problem. Superheating would be worth while if some simple plan could be made whereby the important factors of reliability, cheapness in construction, economy in maintenance and general convenience in arrangement would be assured.

The following description is taken from the patent specifications of an invention by Mr. Jan Von Grubinski of Warsaw, Russia, the essentials of which are a superheater consisting of a drum placed in the smoke box and containing tubes which are virtually extensions of the main boiler flues. The steam on its way from the T head to the cylinders passes through this drum and around the tubes. The condensation from the steam is drained through a small tube at the bottom of the drum. The inventor describes the device as follows:

In the arrangement and details represented in Fig. 1 by a partially longitudinal vertical section and in Fig. 2 by a cross-section the boiler-tubes are connected with the tubes

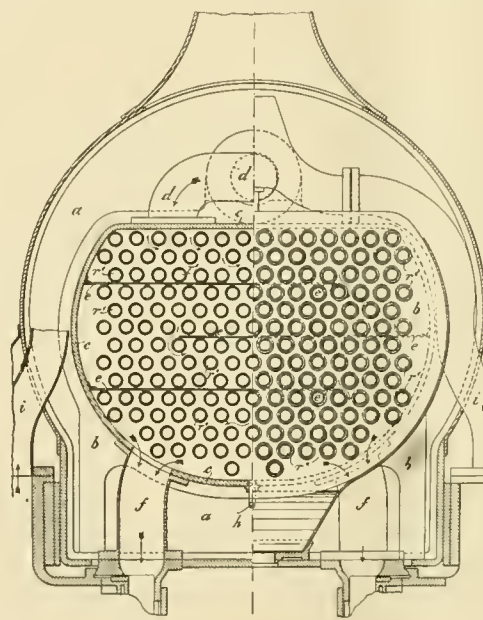
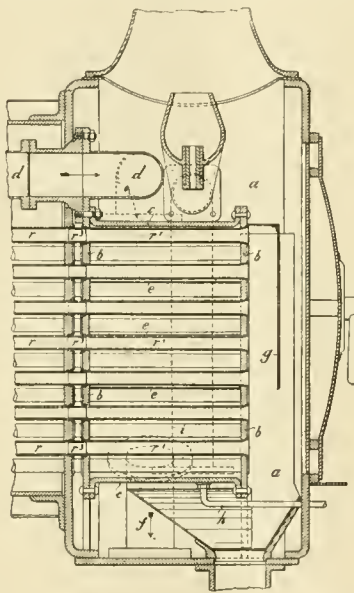

A Superheater for Locomotives.

in the smoke-box by short pieces of piping r^2 , so that the boiler-tubes extend a certain way into the smoke-box a. The chest arranged for the reception of the tubes r^1 consists of two plates b , which connected with one another by means of a casing c and is in connection above with the steam-dome by means of a pipe d and below with the working cylinder of the engine by means of pipes f .

On the side wall of the jacket or casing c are arranged the horizontal partition walls e in such a manner that these, as may be seen from the cross section Fig. 2, leave alternately right and left a free space for the passage of the steam.

The letter g indicates a wall or partition on the front end of the boiler, which is intended to prevent a direct escape of the combustion gases issuing from the upper heating pipes or boiler-tubes r^1 into the stack, and to force the same at first downward and then, mixed with the gases from the lower heating pipes, to pass upward into the stack.

PRESSING WHEELS ON AXLES.

The best relation between the diameter of the wheel fit of axles and the bore of the wheel hub is an interesting question concerning which Mr. G. Leverich recently sent the following communication to the "Street Railway Journal":

Recently there was occasion to investigate the problem of

the proper proportioning of the diameter of certain steel car-wheel hubs and axles to secure the maximum possible grip between the two, and yet have the compression of axle and the extension of bore within the elastic limits of the materials in the axle and wheel. The following was the treatment of the problem:

Let the diameter of the axle be t d and that of the wheel bore, which is of less diameter, be d x . Then the normal circumference of outer surface of axle = πd , and of inner surface of bore = πd x .

When the wheel is forced on the axle, d will be lessened and d x increased, so that, putting d y for the common diameter, the compression of outer surface of axle will be πd $(1 - y)$ and the extension of inner surface of bore will be πd $(y - x)$ and per unit of length, $1 - y$ and $y - x$, respectively.

For per unit of length per maximum safe compression of axle material put a and per maximum safe extension of wheel material put b . Then $1 - y = a$ and $y - x = b$. $\therefore y = 1 - a$ and $x = 1 - a - b$, and the normal diameter of axle = d and the normal diameter of bore = d $(1 - a - b)$. What are the values to be given to a and b is to be determined.

It may be said that so far this discussion has dealt with the outer surface of the axle and the inner surface of the bore, which are to be brought into contact. Whether consideration of the reinforcement of the inner surface of the bore by adjacent and surrounding layers, and similarly of the axle inward, the other being outward, would affect differently the ultimate

query—namely, what safe stress may be put upon the materials in the contact surface, is doubtful.

An empiric solution, probably, is a correct practical one.

Nine steel bars—g. s. m's tests.—ranging in per cent of carbon from 0.09 to 0.559; in elastic limit of tension per sq. in. from 32,540 to 43,310 pounds, and at that stress, in extension per inch from 0.00119 to 0.00161, show an average extension of 0.00129. These bars, each under 30,000 lbs. stress per sq. in. extended per inch varying from 0.00095 to 0.00108, and averaging 0.00104. Rejecting the ninth bar, having carbon 0.559 per cent., the eight remaining bars ranged in carbon from 0.09 to 0.222 per cent. in elastic limits per sq. in., from 32,540 to 37,330 pounds, and at that stress in extension from 0.00119 to 0.00132, with an average of 0.00124. Similarly these bars under 30,000 lbs. tensional stress extended per sq. in. from 0.00095 to 0.00108 with an average of 0.00103.

It may be safe to take the maximum allowable extension per unit of length at .00111 = b and compression per unit of length at one-half this, or .00055 = a .

$$\text{Then } d(1 - a - b) = .99834 d,$$

which is the diameter of bore of the wheel hub, d being that of the axle; or, diameter of bore: diam. axle :: 599:600; that is for steel forged wheels and axles, the diameter of the bore of the wheel, should be one six-hundredth less than the diameter of the axle.

The largest dynamo in the world is being built by the Walker Company of Cleveland, Ohio. It is for the Boston Elevated Railway, and will have a capacity of 3,000 kilowatts at 550 volts, or about 4,000 horse power. The speed will be about 80 revolutions. Its weight is 250,000 pounds, and the diameter of the field frame is 21 feet 7 inches.

WEED BURNER—NORTHERN PACIFIC RAILWAY.

The weed burner, shown by aid of these engravings, was designed and built by the Motive Power Department of the Northern Pacific Railway, and we are informed that it burns ordinary weeds that grow along the tracks at a cost of from \$2 to \$4 per mile, and it will burn about 30 miles per day. The saving effected over hand labor in cutting weeds by a shovel is about \$12 per mile.

The burning outfit is carried on a flat-car, pushed by an eight wheel locomotive, that is especially detailed for this service during the season. The fuel for the burner is oil and the flame is made most effective by an air blast. There are 18 burners carried in a group on a frame hinged to the front end of the car. There are six burners outside of each rail, and six burners between the rails. The frame is ordinarily held so that the shield surrounding the burners is three inches from the rails, but it may be raised out of the way entirely by the chain and air cylinder, supported on the wooden frame shown in the drawing. When down in the working position the frame is supported by the slotted hanger. The office of the shield is

to confine the heat from the burners and deflect it toward the ground, and the heat is so intense as to kill the weeds, roots and all.

The burners are made of 3-inch pipe; the construction being clearly shown in the sectional drawing. The oil comes through the tube at the center of the burner, and the air blast enters at the side and passes around the cone at the end of the oil pipe. The position of the cone may be adjusted by turning the oil tube, which is threaded where it enters the burner. The air pipe connection from the car to the burner flame is made by flexible rubber hose, but the oil pipe attachment required a packed gland joint, which was made as indicated in the views of this special fitting.

The supply of oil is carried in an iron tank, holding 1,600 gallons, which is fitted with a man-hole, and the necessary

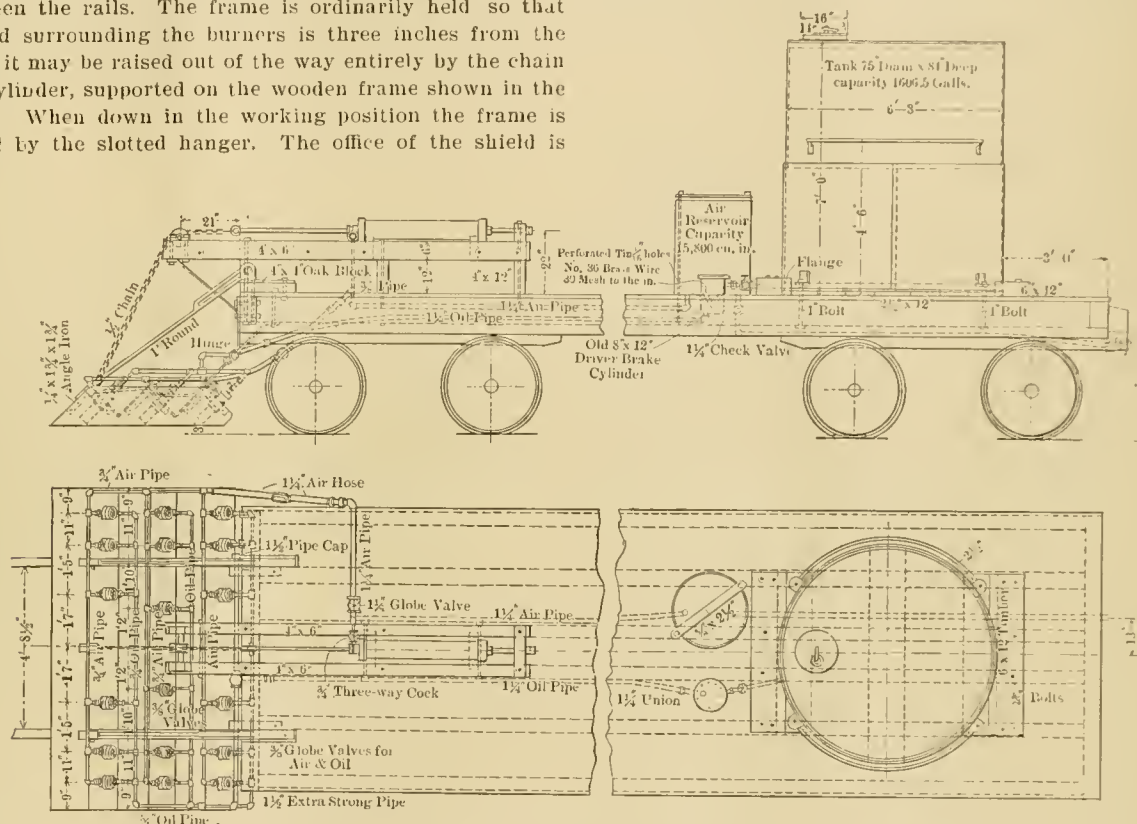

Plan and Elevation of Car.

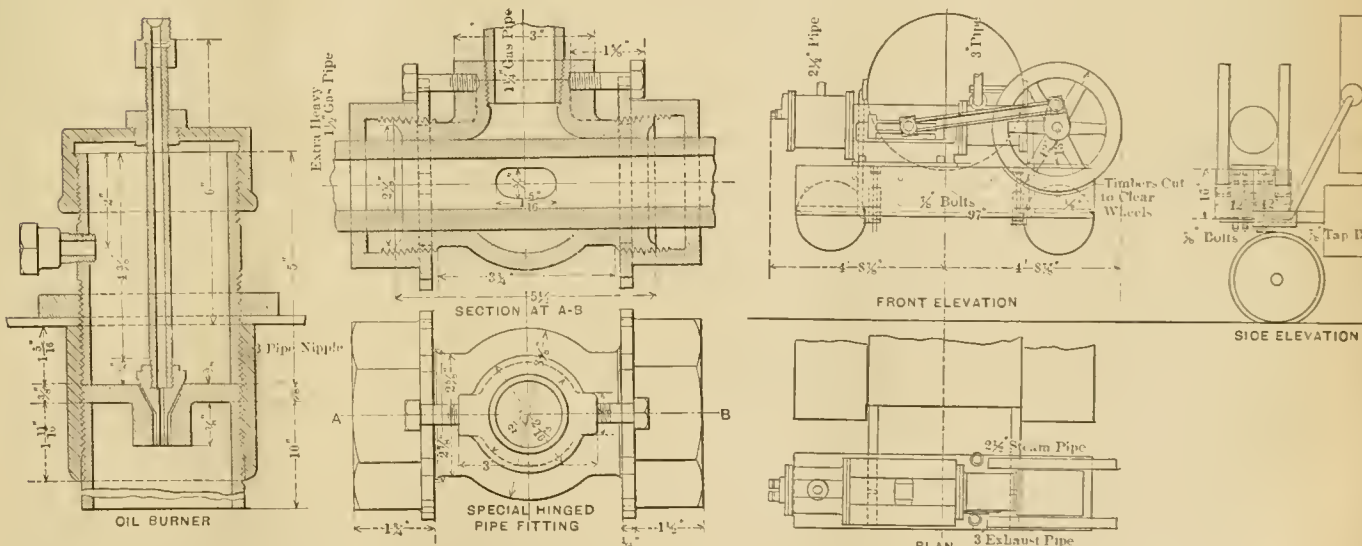

Details of Oil Burner and Hinge Joint.

Location of Air Compressor on Locomotive.

Weed Burning Equipment—Northern Pacific Railway.

pipng. The oil is passed through a strainer pot, made of an old 8x12-inch driver brake cylinder. The strainers are double, one being of tin, perforated with 1-16-inch holes, and the other is No. 36 wire netting, with 30 meshes per inch. These parts and an air reservoir complete the equipment on the burner car.

There is a check valve between the air reservoir and the end of the air supply pipe to prevent air from passing backward through this pipe in case the air supply is cut off suddenly.

There is nothing essentially new in the use of oil in this equipment or in the application of the air blast, but the use of a Rand 10x14 in. straight line air compressor in this connection is new and praiseworthy. The compressor is mounted on the front ends of the engine frames, as shown in the drawing. A 4x4 in. boiler feed pump in the cab furnishes circulating water to cool the air cylinder of the compressor, and this equipment furnishes more air and at a much lower expense than the eight air brake pumps that were formerly used for the same purpose.

THE CHICAGO & MILWAUKEE ELECTRIC RAILWAY.

An electric railway, 85 miles long, connecting Chicago and Milwaukee, has been talked of for several years, and it now seems to be assured that the project will be carried through. The Chicago & Milwaukee Electric Railway Company has the franchise for a line between Evanston and Waukegan, 31 miles, and the part of this from Highland Park to Waukegan was put into service in July, and it is expected that the rapid work on the southern end will complete the line to Evanston before the end of October. The lines of the North Chicago Street Railway will connect with it at Evanston, and also passengers may use the Evanston division of the Chicago, Milwaukee & St. Paul Railway and the Northwestern Elevated Railway into Chicago. Kenosha and Milwaukee are now connected by a line 33 miles long, running through Racine, and the only gaps to be filled are 16 miles between Kenosha and Waukegan and between Highland Park and Evanston.

The route lies along the shore of Lake Michigan and through about fifteen cities and towns, the effect to be expected being to greatly reduce the passenger business of that division of the Chicago & Northwestern Railway that lies just west of the

electric line, except north of Chicago, where the tracks of the electric road pass through subways under the Chicago & Northwestern and the Elgin, Joliet & Eastern Railways. There are to be no crossings with steam roads at grade. The fares are expected to be about half those of the Chicago & Northwestern for corresponding distances.

The road is at present a single track line, with sidings but will probably be double-tracked next year. The line, except for a distance of about 8 miles, follows the highways, and the 8 miles is an independent right of way, fenced in. The rail is of 65 and 72-lb. "T" and "Shanghai" sections, laid on ties in slug and broken stone ballast. The work is being done by C. E. Loss & Co., of Chicago, contractors, under the direction of Mr. B. J. Arnold, Consulting Engineer.

The electrical distribution system was planned to save copper in the conductors. It employs a combination of direct current for the sections of the road near the power house, and a three-phase alternating current system, with substations for the parts of the line at a distance from the power house. A substation is located at Waukegan, and the power house is at Highwood. An 8 mile three-phase transmission line, carrying a 5,500-volt current on three No. 8 wires, connects the power house with the substation. The trolley wire is No. 00 from the substation and a No. 0000 feeder extends 4 miles south and 3½ miles north of the station. There are two types of generators. The three-phase machines have a capacity of 250 kilowatts at 125 revolutions. Each of the alternating generators has 24 poles, delivering a three-phase current of 25 cycles per second at a potential of 5,500 volts to the transmission line. The combination generators are also of 250 kilowatts capacity, running at 125 revolutions, and the current may be either direct or three-phase. There is but one armature, but the windings are

connected on one side to a commutator, and on the other side to collector rings. The direct current is of 600 volts, and the three-phase current 380 volts. The low voltage is raised to 5,500 when sent to the substation by means of transformers in the basement of the power house. The "Arnold system" of connecting engines and generators is used, being a great improvement on the ordinary direct connected plan. When the line is completed the substations will have step-down transformers, a rotary converter and a storage battery. A part of the plan is to mount the machinery needed for a substation upon a car fitted with motors, so that it may be sent out to a substation for use in case of break-downs, and before the arrival of the portable substation outfit the storage battery may be relied on to keep the cars moving. The cars will have 35 H. P. motors for the four-wheel type and 50 H. P. motors for the eight-wheel type, and the larger cars are expected to attain full speed of 30 miles per hour in 19 seconds. Ten cars are now in use.

A great deal of attention has been paid to the steam plant. Steam will be furnished by six 250 H. P. Cahall-Babcock & Wilcox water-tube boilers, with Hawley down-draft furnaces, three of which are now in use. They are fed by the Q & C Company's apparatus, recently illustrated in our pages, and there is to be a fuel economizer for each pair of boilers.

WATER TUBE BOILERS ON THE U. S. GUNBOAT "MARIETTA."

The wonderful performance of the battleship "Oregon" has had a great deal of attention, but much less has been given to the equally brilliant performance of her consort, the "Marietta," on the trip around the "Horn." This vessel is 174 feet long, 34 feet beam, 12 feet draft and the displacement is 1,000 tons. She has twin screw engines, with cylinders 12, 18 and 28 inches diameter, and 18 inches stroke. The boilers are by the Babcock & Wilcox Company, and are 11 feet 6 inches long by 9 feet 6 inches wide, and 11 feet high. The total grate surface is 94 square feet, and the total heating surface 3,620 square feet. The total weight of the boilers is 94,016 pounds, complete with heaters, and with water and all fittings and attachments the weight is 112,000 pounds.

The performance of this vessel was due chiefly to the boilers. The trip was made as far as Rio de Janeiro in company with the "Oregon," and the "Marietta" proceeded alone for the rest of the way. The contract guarantee for the "Marietta" was but twelve knots, and as she had to make thirteen knots in order to keep up with the battleship, the performance is remarkable, even more so than that of the larger ship. Chief Engineer Melville has long been in favor of water tube boilers for naval vessels, and this experience will tend to confirm his position. The vessel was not delayed a moment by her boilers, and no repairs were made to them during the trip. It may therefore be said that these boilers came through this long voyage in perfect condition, which is more than could be said of other forms of boilers. The vessel has been in service since her arrival at Key West, which should convince those who have not favored this type that their position is weak. Chief Engineer W. H. Chambers reported to the Navy Department upon the trials preliminary to the long voyage, and the total consumption of fuel, including that for all auxiliary purposes, is remarkably low. He said:

"Runs were made for periods of forty-eight hours each, the engine revolutions being maintained at as near a constant rate as possible, and a careful account kept of the distance run and the amount of coal burned during these times. Three different rates of revolutions of engine were taken, giving speeds of 10½, 9½ and 8½ knots respectively. At the 8½-knot speed the wonderfully small coal consumption of 6½ tons a day was obtained, or 1.52 pounds per indicated horse power. In other words, the "Marietta" steamed 264 miles a day on only 6½ tons of coal, or could go more than 7,500 miles on her coal supply."

It is significant that the three new battleships are to have water tube boilers, and Babcock & Wilcox boilers have been put into the "Chicago" and "Atlanta." In a communication by Mr. James H. Rosenthal, printed by "Engineering" (London), it is stated that Babcock & Wilcox boilers have been applied to upward of 60 ships, and among them H. M. S. "Sheldrake," which is soon to go into commission. There are seven of these vessels in the United States navy. Mr. Rosenthal also gives interesting figures from tests on S. S. "Otto" and S. S. "Rollo," in which the pounds of coal per indicated horse power per hour were 1.5 and 1.6 respectively.

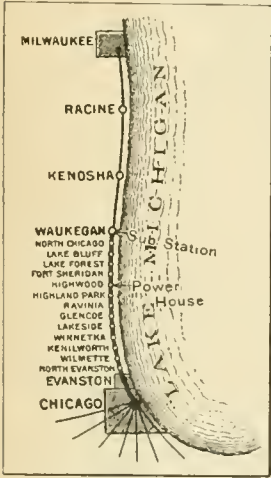

SEARCH-LIGHT ATTACHMENT TO LOCOMOTIVE HEADLIGHTS.

An arrangement for turning locomotive headlights on a vertical axis for the purpose of throwing the light upon the tracks on curves, designed and patented by Mr. John S. Thurman, Mechanical Engineer of the Missouri Pacific Railway, is illustrated in the accompanying engraving. The drawing shows an electric headlight with the motor and dynamo mounted together on a table, on the under side of which the turning mechanism is secured. The headlight is mounted on a turntable, which is rotated through the proper angle by a cable passing around pulleys and leading to the two piston rods of a 2¼-inch double-acting air cylinder.

The motion of the piston is regulated by a valve in the cab, the air pressure being taken from the air brake system. The surface on which the headlight turns is in the form of inclines, so arranged that when the headlight travels up the in-

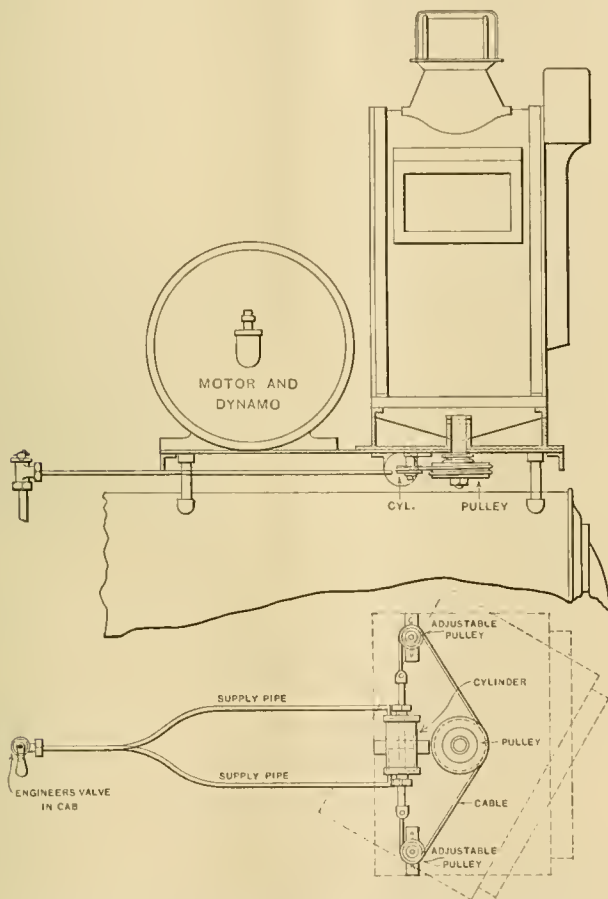

Search-light Attachment for Locomotive Headlights.

cline it will have bearings on the two quarters on which it travels. The object of this is to return the headlight to its normal position automatically when the air is released. The device has been tried on three Western roads, and the engineers like it. They say that they can see ahead as well on curves as on straight track. It is equally well adapted to headlights using oil.

MASTER MECHANICS' ASSOCIATION, COMMITTEES FOR 1899.

The subjects for report at the next convention of the Master Mechanics' Association and the members appointed on the committees have been selected by the Executive Committee and are as follows:

- 1—A Research Laboratory Under the Control of the Association.—Wm. Forsyth, W. F. M. Goss, John Player.
- 2—The Best Methods of Preventing Trouble in Boilers from Water Impurities.—A. E. Manchester, J. H. Manning, S. P. Bush, H. Bartlett, R. M. Galbraith.

3—Relative Merits of Cast-Iron and Steel-Tired Wheels for Locomotives and Passenger Car Equipment.—J. N. Barr, H. S. Hayward, A. M. Waitt.

4—Advantages of the Ton-Mile Basis for Motive Power Statistics.—H. J. Small, C. H. Quereau, W. H. Marshall.

5—Best Method of Applying Stay Bolts to Locomotive Boilers, Including Making the Bolts and Preparing the Stay Bolt Holes.—G. F. Wilson, S. M. Vauclain, T. A. Lawes.

6—Is It Desirable to Have Flanged Tires on All the Drivers of Mogul, Ten-Wheel and Consolidation Engines? If So, with What Clearance Should They Be Set?—S. Higgins, W. H. Thomas, Wm. Garstang.

7—Best Form of Fire Box to Prevent Cracking. Is It Advisable to Use One Piece for Crown and Side Sheets? H. Monkhouse, T. R. Browne, B. Haskell.

8—The use of Nickel Steel in Locomotive Construction; Its Advantages and Proper Proportion of Nickel.—A. E. Mitchell, Pulaski Leeds, Tracy Lyon.

9—Subjects, R. Atkinson, John Hickey, G. R. Henderson.

EXAMINATION OF EMPLOYEES.

In self defense railroads ought to exercise great care in the selection of men to secure those who are physically and mentally qualified for their duties. The rigidity of the physical examination for enlistment in the army and navy has been criticised, but now that the war is over the justification of the severity is apparent.

Railroads have the same reasons for selecting men who are up to a high health standard and who are properly qualified mentally. They have, indeed, more reason for care than the Government, because a road is liable for the damage caused by ignorant or incompetent men, yet the proceedings of the last meeting of the Association of Railroad Surgeons show that neglect of proper precautions is very common. This may work a hardship upon an occasional individual, but the benefit of the many demands the most careful selection of men for such responsible work. If it is important to select the material for the construction of road and rolling stock and test it for imperfections, it appears to be at least equally important to use the same degree of care in selecting men.

The Chicago, Rock Island & Pacific Railway has set an example in this respect by requiring physical examinations very much like those of the military service. We have a copy of the blank application for employment, and it combines searching questions for the applicant to answer, including his education, record of service and experience, with a blank certificate for the surgeon's examination. The latter includes vision, color sense and hearing records, and has charts showing the skeleton for the purpose of locating deformities. Otherwise it strongly resembles a life insurance blank.

This blank is used for applicants for employment as agents, operators, station baggagemen, engineers, firemen, engine dispatchers, conductors, switchmen and all who have to do with the handling of trains. The candidate's portion is filled out and the applicant reports to the nearest company's surgeon for the sight and hearing test; then, if he desires to enter train or switching service, he is subjected to the physical examination. The surgeon making the tests and examination reports on the application blank, and sends one copy to the division superintendent or the master mechanic and another to the chief surgeon. Reading and writing are required of all candidates, and the applicant's history for the previous five years must be given, special reference being made to any railroad service and the reasons for leaving it. The paper is complete, and its use must insure the possession of knowledge necessary to deciding upon the desirability of the candidate.

ANOTHER WESTINGHOUSE LONG-DISTANCE TRANSMISSION PLANT.

Contracts involving ten thousand horse power are not common. Especially is this true when the agreement is to transmit this enormous amount of power over a distance of 45 miles. And when the contract further stipulates that the losses in generators, transformers and line shall remain normal, notwithstanding the difficulties involved, the agreement then becomes of still greater interest.

Such a contract has just been executed by the Westinghouse Electric & Manufacturing Company, in which they agree to comply with the above conditions. The plant is for the Snoqualmie Falls Electric Power Co., of Snoqualmie Falls, Washington.

The power station is to be located at Snoqualmie Falls, 45

miles from Tacoma and 31 miles from Seattle, to which places the current is to be transmitted, and then utilized by Westinghouse motors.

The contract involves the building and delivery at above points of four three phase, rotary armature generators, having a normal aggregate capacity of 6,000 kilowatts, and which are to be direct connected to water wheels; two 75 kilowatt kodak exciter dynamos, also to be direct connected to water wheels; high and low potential switchboards, for main power station and sub-stations at Seattle and Tacoma, involving 76 marble panels with all necessary instruments, switches, etc.; high tension oil insulated static transformers, having an aggregate capacity of 10,875 kilowatts; rotary transformers with a total output of 2,700 kilowatts and 6 type "C" motors developing 1,600 horse power, with adequate lightning protection at both ends of the line.

These machines, when installed, will make the power of Snoqualmie Falls available for industrial, railway and lighting purposes. The line potential will be 25,000 volts, and its current will be carried over bare aluminum wires to sub-stations, where lowering transformers will reduce the voltage sufficiently for safe transmission within the corporate limits of the two cities.

TIE PLATES RECOMMENDED BY ROADMASTERS' ASSOCIATION.

At the convention of the Roadmasters' Association held in Denver the Committee on Tie Plates presented an interesting and valuable report, from which we quote the following opinions and recommendations:

Considering the cases which have come under the personal observation of this committee in connection with the answers to inquiries which we have sent out to many experienced railroad men who have used the various types of tie plates, we submit recommendations as to the general construction and use of tie plates, together with the facts and general information from which we have drawn these recommendations:

Recommendations.

First—That tie plates be used always in preference to rail braces for greater safety and higher economy.

Second—That tie plates be used on all ties where the life of the tie is limited by the cutting or sawing action of the rail.

Third—That tie plates be used on all ties whose life is limited on account of the destruction caused by spike killing.

Fourth—That tie plates with soft ties be used in preference to hard ties without any plates, when the natural life of the soft tie is equal to or greater than the natural life of the hard tie, cost being equal.

Fifth—That the only plate used be one which becomes practically part of the tie.

Sixth—That as a tie plate is intended to prevent the cutting action of the rail flange across the wood fibers of the tie, the plate used should not itself cut such fibers and should prevent the rail from cutting them.

Seventh—That a tie plate having sufficient thickness to resist buckling, sand wear and rust, during the natural life of the tie, should be used.

In connection with the records of experience with tie plates a number of reports were presented, among which two are quoted as follows:

An old, experienced roadmaster, who has about 70,000 Servis plates in track, has used them on "2½ degrees with oak, on cedar switch sets, and on center joint ties, where three ties are used." He applies them "by the aid of Ware's tie plate surfer and gage," and cost of applying is ½ cent ties out of track and less than 1 cent when ties are in track. Oak ties used in both cases. He uses them on every tie, and finds they do not move longitudinally, and does not know which plate lengthens the life of the tie most. Under "remarks" he says: "Having had 45,000 in use since 1892, on oak ties and on curves of 5 degrees to 7½ degrees, have not had to regage any part of it. The surface of the plates has not gone below the surface of the tie, and work of surfacing and regaging, caused by the rail cutting into the ties, has been entirely eliminated by their use. As an element of safety they are invaluable."

An engineer, M. of W. of a large traffic line, which has been one of the most extensive users of tie plates for years, writes: "We have been using Servis tie plates for several years past.

... A great saving in the cost of tie renewals, and consequently in the expense of track maintenance, will be secured by their use. The kind of ties particularly used by us are redwood, the natural life of which (under heavy traffic) is seven years. With the use of tie plates we hope to at least double this period."

ELECTRICALLY DRIVEN ANGLE IRON SHEARING MACHINE.

The machine shown in this illustration is designed for cutting up angle iron, and is built by The Long & Allstatter Company of Hamilton, Ohio, who manufacture punching and shearing machinery of all kinds and sizes. It is adapted to cutting material off square, at mitre or at any other angle, either right or left hand. The shears are operated by means of a steel cam shaft, which is arranged so that it may be turned by hand from the front of the machine, a great convenience in setting the blades. The table is of iron, and is provided with a gage for setting the bar to the desired angle. Hold-down screws on the front of the machine hold the bar down and prevent it from tipping up as the knife comes down. An automatic stop movement brings the machine to rest with the shears open, thus permitting the accurate adjustment of the bar to be cut. The machine is mounted on a patent revolving table, so that it can be turned either to the right or the left, and accurately set to the desired angle to which the bar is to be cut, without moving the bar from its normal position when being cut off at a right angle.

The illustration shows the machine driven by a Tesla polyphase motor, made by The Westinghouse Electric & Manufacturing Company, of Pittsburgh, but can be furnished with steam engine attached, in both cases the machine being independent of shafting. If desired it may be arranged with tight and loose pulleys and driven by

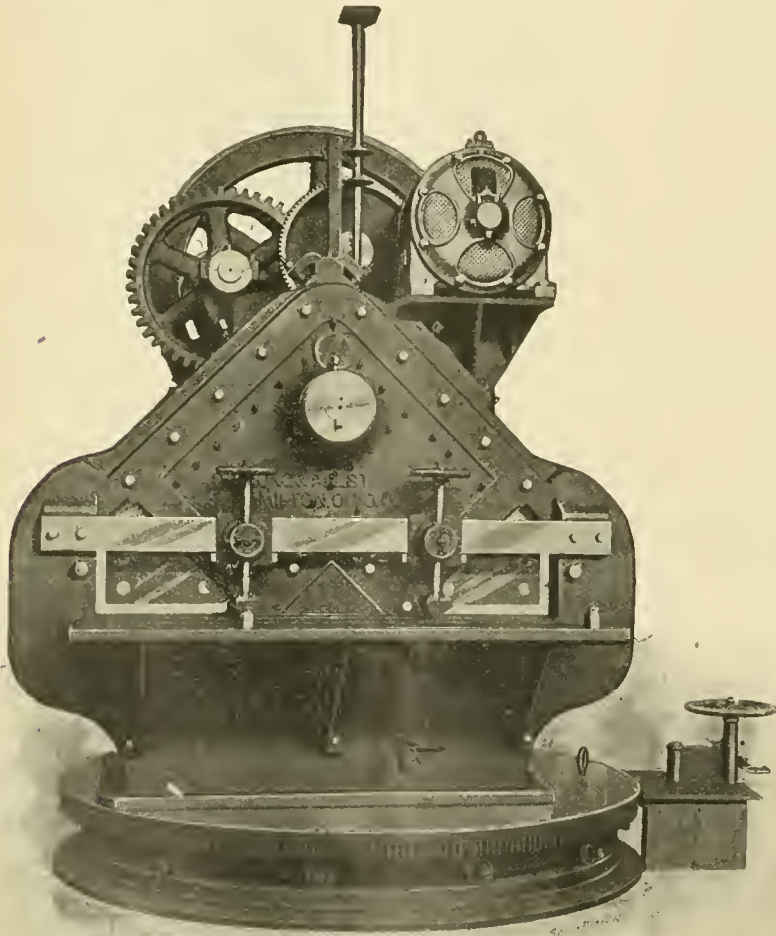

Angle Shears, Long & Allstatter Co. Driven by Type "C" Tesla Motor.

belt. These machines are also made with independent shafts and slides, or in any other form that is found desirable. The manufacturers build seven different sizes of this machine, the smallest being adapted for shearing up to 3 by 3 by $\frac{3}{8}$ inch angles, while the largest is suitable for shearing the heaviest sections.

THE BARTOW BELL RINGER.

The Chicago Pneumatic Tool Company has just placed a simple pneumatic bell ringer upon the market which appears to have advantages over others that we have seen. As shown by the engraving, it is very simple and has few parts, which should result in good wearing qualities, and low expense for repairs. The device has been in successful use for about two years on several Eastern roads, and no repairs have been required in this time.

There is no direct connection between the bell and the motor operating it. The cylinder, which operates by compressed air, is carried on a bracket bolted to the bell frame.

The piston rod carries a disc at its upper end which operates the bell by means of a roller on the end of the bell crank. The valve is moved by a rod having two tappets and is controlled by an arm extending from the piston rod of the ringer. The tappets are in the form of adjustable nuts, whereby the length of stroke and rapidity of operation are adjusted. The claims urged for this ringer are simplicity, ease of attachment and economy in operation. The cylinder takes air from the main reservoir on the engine, and as the stroke of the piston is very short, and the diameter of the cylinder is only 1 $\frac{1}{4}$ inches, very little air is used. In fact, the amount consumed cannot be noticed in the operation of the engine. The company referred to states that it has been shown that one of these engines saved enough fuel to pay for its cost in a single month, because of leaving the fireman free to attend to the fire instead of watching for crossings. The ringer is controlled by a valve in the cab. Bell ringers are commonly used in large sections of the country, and we believe that once adopted they are never discarded.

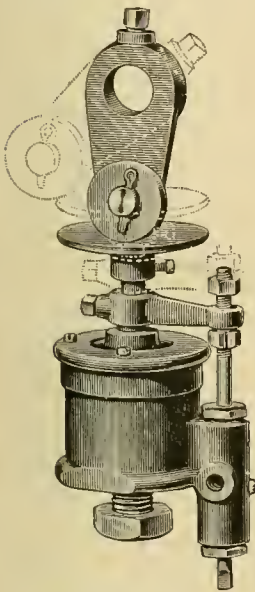

The Bartow Bell Ringer.

LUXURY IN SIBERIA.

The new Siberian train which was recently sent to St. Petersburg for the approval of Prince Hilkef, Minister of Ways and Communications, returned to Moscow, after being personally inspected by the Czar. This is the second train specially built for the quick service on the Great Siberian Railway. It is, says the Moscow correspondent of "The Standard," an improvement on the first specially built train, which was a marvel to Russians. The new train consists of five coaches, two for second-class and one for first-class passengers; the others are a dining and a baggage car. The construction is of the newest design, and the train runs with great smoothness. Besides the comforts of a bathroom with gymnastic apparatus, a library of books in several languages, a piano and selections of music, maps, guide books, albums of views, an ice cellar, and an arrangement for boiling water in three minutes by means of steam, which were found in the first train, the new one is fitted with plates which indicate the next stopping station, and, if the stoppage be over five minutes, also how long the train stops.

All the windows are protected from dust and wind by external plate-glass guards; the last coach is arranged to serve as an "observation car," showing views of the country traversed. A stationary bicycle, with arrangements for measuring in minutes and kilometers the amount of work done; a barber, who is qualified to give medical assistance, and a superintendent who speaks Russian, French, German and English,

are among the other conveniences to comfort of traveling now provided. The train will be lighted inside and out by electricity, and electric cigar lighters find a place in the dining car. A laboratory has been fitted in the second-class car, so as to be available for the enthusiastic photographer to change plates and develop them during the journey. Electric bells and portable electric reading lamps are in each compartment. The kitchen is intended to furnish a hot dinner for a maximum of sixty people. Paper and envelopes are to be supplied gratis at the buffet, where hot and cold drinks of all kinds are to be had; there is no charge for the barber, but two rubles is the price for a bath, for which three hours' notice beforehand must be given.

CHEAP RAILWAY RATES IN SWITZERLAND.

Railway traveling in Switzerland has, since June 1, undergone quite a revolution in the delivery of tickets and their extraordinary cheapness. A great blow has been given by the railway administration to the formerly advantageous tourist or circular ticket.

The following is the series of tickets delivered at all the most important stations at a couple of hours' notice and at all small stations at twenty-four hours' notice:

Tickets for one person, valid for—	1st Class.	2d Class.	3d Class.
15 days..	\$11.53	\$5.11	\$5.79
30 days.....	19.39	13.51	9.65
3 months.....	46.32	32.81	23.16
6 months.....	73.34	51.11	36.67
12 months.....	115.80	81.06	57.99

These new tickets enable the holder to travel as much and as long as he likes over the entire railway system of Switzerland during the time of the validity of his ticket. The lake steamers are also available, a second-class railway ticket giving the right to a first-class ticket on the steamers. These tickets are rigorously personal, and have attached to them a photograph of the holder. Tickets must be signed with the holder's entire name. An extra sum of 5 francs (97 cents), has to be paid upon delivery, which, however, is returned when the ticket expires. The duration of these tickets cannot be prolonged. No luggage is allowed free, and no allowance is made for tickets unused.

M. C. B. COUPLERS—WEIGHTS AND MANUFACTURERS.

We are often asked for addresses of coupler makers, and a list of the Master Car Builders' couplers, with weights of the parts and the names and addresses of the manufacturers will be convenient for reference. This list was prepared by Mr. John W. Cloud, Secretary of the Master Car Builders' Association, and sent out to members in the form of a circular, in accordance with a recommendation of the Committee on Prices. The list is as follows:

- American Coupler.—American Coupler company, 1413 Fisher building, Chicago, Ill. Bar, 160 pounds; lock, complete, 9 pounds; pin, 5 pounds; knuckle, 46 pounds.
- Buckeye Coupler.—The Buckeye Malleable Iron & Coupler company, Columbus, Ohio. Drawhead, for freight cars, 156 pounds; drawhead, with 6-inch shank, for freight cars, 166 pounds; drawhead, with long shank, for passenger cars, 160 pounds; knuckle, 46 pounds; lock, 7 pounds; lock link, $\frac{7}{8}$ pound; pivot pin, 5 pounds; pivot pin for safety attachment, 10 pounds.
- Burns Coupler.—Syracuse Malleable Iron Works, Syracuse, N. Y. Drawhead, 151 $\frac{1}{2}$ pounds; knuckle, 45 $\frac{1}{2}$ pounds; lock, 6 $\frac{3}{4}$ pounds; pin, 4 $\frac{1}{4}$ pounds; pivot pin, 5 $\frac{1}{2}$ pounds; knuckle opener, 1 $\frac{3}{4}$ pounds.
- Chicago Coupler.—Latrobe Steel & Coupler company; office, Old Colony building, Chicago, Ill.
 - Freight Car Coupler: Drawbar, steel, 156 pounds; knuckle, steel, 54 pounds; locking arm, steel, 9 pounds; pivot pin, steel, 6 pounds; lifting pin, steel, 3 pounds.
 - Passenger Car Coupler: Drawbar, steel, 190 pounds; knuckle, steel, 55 pounds; locking arm, steel, 9 pounds; pivot pin, steel, 6 pounds.
- The weight of the Chicago coupler varies with the type of shank used:
 - Drawbar for M. C. B. standard strap attachment weighs 154 lbs.
 - Drawbar for M. C. B. tall-bolt attachment weighs.....156 "
 - Drawbar for M. C. B. combination shank weighs.....155 "
 - Drawbar for M. C. B. Amer. continuous draught weighs 162 "
- Columbia Coupler.—Latrobe Steel & Coupler company; office, Old Colony building, Chicago, Ill. Drawbar, steel, 175 pounds; knuckle, steel, 48 pounds; locking pin, steel, 8 pounds; pivot pin, steel, 6 pounds.
- Detroit Coupler.—Michigan Malleable Iron company, Detroit, Mich. Shank, 160 $\frac{1}{2}$ pounds; knuckle, 47 $\frac{3}{4}$ pounds; lock, 8 pounds; lock lifter, 1 $\frac{1}{2}$ pounds; pivotal pin, 7 $\frac{1}{4}$ pounds; lock rivets, $\frac{1}{2}$ pound; clevis and pin, 1 pound.
- Drexel Coupler.—Drexel Railway Supply company, Rookery building, Chicago, Ill. Body, 135 pounds; knuckle, 52 pounds; lock, 10 pounds; fulcrum pin, 5 pounds; clevis, 1 pound.

- Elliott Coupler.**—The Elliott Car company, Gadsden, Ala. Coupler skeleton, malleable, 182 pounds; lock, malleable, 5½ pounds; knuckle, steel, 41 pounds; spring, steel, 11-16 pound; pin, wrought-iron, 5 pounds; lift, wrought-iron, 1 pound.
- Erie Coupler.**—Erie Malleable Iron company, limited, Erie, Pa. Coupler body, malleable, 150 pounds; knuckle, steel, 52 pounds; lock, malleable, and chain, steel, 15 pounds; knuckle pin and lock pin, steel, 6¾ pounds.
- Forsyth Coupler.**—Ross-Meehan Foundry Company, Chattanooga, Tenn. Shank, malleable, 150 pounds; lock, malleable, 4 pounds; lock lever, malleable, 5 pounds; knuckle, steel, 49 pounds; knuckle pin, steel, 8 pounds.
- Gallager Coupler.**—Gallager Coupler & Unlocking Attachment company, Savannah, Ga. Freight Coupler: Coupler head, malleable, 157 pounds; knuckle, cast-steel, 38½ pounds; locking dog, malleable, 4½ pounds; unlocking pin, malleable, 1 pound; knuckle pin, iron or steel, 5 pounds. Passenger Coupler: Coupler head, malleable, 162 pounds; knuckle, cast-steel, 38½ pounds; locking dog, malleable, 4½ pounds; unlocking pin, malleable, 1 pound; knuckle pin, iron or steel, 5 pounds.
- Gould Coupler.**—Gould Coupler company, 66 Broadway, New York. Freight Coupler: Head, 175 pounds; knuckle, 38 pounds; knuckle pin, 8 pounds; lock pin, 1 pound; knuckle lock, 8 pounds; chain, 2 pounds. Passenger Coupler: Head, 209 pounds; knuckle, 38 pounds; knuckle pin, 8 pounds; clevis, 1½ pounds; nut, ½ pound; lock, 8 pounds; lock link, 2 pounds; lock staple, ½ pound; spring stems, 1½ pounds; springs, ½ pounds; lock pin, 1 pound; clevis pin, ½ pound.
- Hien Coupler.**—The Railroad Supply company, Owings building, Chicago, Ill. Freight Coupler: Shank, malleable, 135 pounds; shank, steel, 140 pounds; knuckle, 42 pounds; other parts, 22 pounds.
- Hinson Coupler.**—Hinson Manufacturing company, Gaff building, Chicago, Ill. Drawbar head, 160 pounds; knuckle, 50 pounds; lock, 7 pounds; hangers, 3 pounds.
- Janney Coupler.**—The McConway & Torley company, Pittsburg, Pa. Freight Coupler: Coupler casting, 179 pounds; wrought knuckle, 37.5 pounds; knuckle pin, 5.5 pounds; locking pin No. 96, wrought-iron, fitted, 10.5 pounds; release lever keeper, 1.6 pounds; release lever lock, 2.4 pounds; release lever angle, clips and bolt, 1.5 pounds; clevis and pin, fitted, ½ pound. Passenger Coupler: Coupler casting No. 1, 154 pounds; coupler casting No. 1-P, 158 pounds; Janney-Buhoup coupler casting No. 1-J-B, 148 pounds; Janney-Buhoup coupler casting No. 1 J-B-P, 151 pounds; knuckle, No. 2-B, 37½ pounds; knuckle pin No. 16, 5¼ pounds; catch No. 3, 5 pounds; horn No. 130, 2 pounds; catch lever No. 22, 7½ pounds.
- Little Delaware Coupler.**—Wilmington Malleable Iron company, Wilmington, Del. Shank, 144 pounds; knuckle, 50 pounds; hinge pin, 5 pounds; lock, 5 pounds; lever, shackle and pin, 1½ pounds.
- Lone Star Coupler.**—The Franklin Steel Casting company, Franklin, Pa. Shank, 160 pounds; knuckle, 50 pounds; lock and link, 10 pounds; pin, 6 pounds.
- Ludlow Coupler (Class A).**—Springfield Malleable Iron company, Springfield, Ohio. Freight Coupler: Bar or shank, malleable, 140 pounds; knuckle, steel, 61 pounds; locking pin, steel, 6.8 pounds; hinge pin, steel, 6.8 pounds; locking pin clevis, malleable, 0.1 pound; annulus, malleable, 1.3 pounds.
- Mather Coupler.**—A. C. Mather & Co., 1320 Marquette building, Chicago. Drawbar, malleable, 165 pounds; drawbar lock, malleable, 7 pounds; knuckle, steel, 36 pounds; knuckle pin, wrought, 5 pounds.
- Missouri Pacific.**—American Steel Foundry company, St. Louis, Mo. Shank, cast-steel, 176 pounds; knuckle, cast-steel, 50 pounds; lock, cast-steel, 10 pounds; hinge pin, wrought-steel, 6 pounds.
- Murphy Coupler.**—The Marion Car Coupler company, Marion, O. Coupler body, malleable, 138 pounds; knuckle, steel, 48 pounds; knuckle pin, steel, 5 pounds; lock, malleable, 7½ pounds; lock pin, malleable, 1½ pounds.
- National Coupler.**—National Car Coupler company, Monadnock building, Chicago, Ill. Freight Coupler G-1: Coupler, all steel, stem or bar, 146 pounds; knuckle G-2, 44 pounds; lock G-3, 9½ pounds; pivot pin, 5½ pounds. Freight Coupler A-1: All steel; bar, 143 pounds; knuckle A-2, 44 pounds; lock A-3, 9½ pounds; lock pin A-4, 2½ pounds; unlocking lever A-5, 3½ pounds; pivot pin, 5½ pounds. Perfected Freight Coupler: All steel; bar No. 1, 150 pounds; No. 2 knuckle, 50 pounds; lock No. 3, 9 pounds. (The National A-2 and Perfected are not manufactured now, except the supplies, G-1 being standard freight coupler.) National Passenger Coupler: All steel; bar No. 5-P, without wrought-iron extension, 192 pounds; M. C. B. knuckle No. 2-P, 44 pounds; lock No. 3-P, 10 pounds; side unlocking lever No. 4½-P, 4 pounds; bottom unlocking lever No. 4-P, 4 pounds. When this coupler is used as Miller M. C. B. combination, add 68 pounds for Miller knuckle to No. 8-P.
- New York Coupler.**—New York Coupler company, 120-122 Liberty street, New York. Shank, 165 pounds; knuckle, 53 pounds; hinge pin, 9 pounds; lock, 4 pounds; lock lever, 1 pound; lock pin, ½ pound; shackle and pin, ½ pound.
- Peerless Coupler.**—Peerless Coupler company, 20 Broad street, New York. Shank, malleable, 140 pounds; knuckle, steel, 39 pounds; knuckle pin, steel, 7 pounds; lock, wrought, 4 pounds; lifting lever, wrought, 3 pounds.
- Pooley Coupler.**—Pratt & Letchworth company, Buffalo, N. Y. Barrel, 159 pounds; knuckle, 38 pounds; dog, 9 pounds; kicker, 4½ pounds.
- S., H. & H. Coupler.**—Shickle, Harrison & Howard Iron company, St. Louis, Mo. Shank, 165 pounds; knuckle, 51 pounds; knuckle pin, 6 pounds; knuckle lock, 14 pounds; knuckle opener, 3 pounds.
- Smillie Coupler.**—The Smillie Coupler & Manufacturing company, Newark, N. J. Shank, malleable, 150 pounds; knuckle, steel, 55 pounds; No. 8 locking pin, 7 9-16 pounds; No. 9 pivot pin, 4 11-16 pounds; lifting chain, clevises, etc., 1 7-16 pounds.
- Smith Coupler.**—American Steel Foundry company, St. Louis, Mo. Shank, cast-steel, 150 pounds; knuckle, cast-steel, 47 pounds; lock, cast-steel, 10 pounds; lock lift, cast-steel, 2 pounds; hinge pin, wrought-steel, 6 pounds.
- Solid Coupler.**—Michigan Malleable Iron company, Detroit, Mich. Shank, 154 pounds; knuckle, 49½ pounds; lock, 9¼ pounds; pivotal pin, 7¼ pounds; lock-retaining pin, ½ pound; clevis and pin, 1 pound.
- Standard Coupler.**—Standard Coupler company, 26 Cortlandt street, New York. Improved Standard: Drawhead, malleable, 140 pounds; knuckle, forged-steel, 66 pounds; locking pins, forged-steel, 7½ pounds. Standard: Knuckle, cast-steel, 55 pounds; locking pins, forged-steel, 10½ pounds.
- St. Louis Coupler.**—St. Louis Car Coupler Co., St. Louis, Mo. Drawbar, steel, 143 pounds; knuckle, steel, 54 pounds; locking pin, steel, 6 pounds; pivot pin, steel, 5 pounds.
- Talbot Coupler.**—American Steel Foundry company, St. Louis, Mo. Shank, cast-steel, 176 pounds; knuckle, cast-steel, 50 pounds; lock, cast-steel, 10 pounds; hinge pin, wrought-steel, 6 pounds.
- Thurmond Coupler.**—I. G. Johnson & Co., Spuyten Duyvil, New York city. Drawhead, malleable, 143 pounds; knuckle, steel, 47 pounds; lock, steel, 10 pounds; pivot pin, wrought-steel, 5 pounds.
- Tower Coupler.**—The National Malleable Casting company, Cleveland, O. Freight Coupler: Coupler head, 145 pounds; knuckle, 53 pounds; lock, 10 pounds; pivot pin, 6½ pounds; chain, 1¾ pounds; clevis, ¾ pound.
- Trojan Coupler.**—The Trojan Car Coupler company, Troy, N. Y. Freight Coupler: Drawhead, casting only, 135 pounds; knuckle, 50 pounds; operating rod, 5 pounds; knuckle pin, 5 pounds; finger, 2¼ pounds; knuckle lock, 13 pounds.
- Williams Coupler.**—Dyer Williams, 1425 Monadnock block, Chicago, Ill. Bar, 148 pounds; knuckle, 40 pounds; lock, 4 pounds; other small parts, 6 pounds. The Ajax, California, Champion, Diamond, Edwards, Empire, Eureka, Interstate, Johnston, Pacific, Taylor and Washburn coupler companies were asked to quote weights, but failed to respond.

JOURNAL BEARINGS AND HOT BOXES.

One of the topical discussions before the M. C. B. Association on journal boxes was opened by Mr. H. F. Ball as follows:

The present Master Car Builders' journal boxes, stop wedges, brasses and lids.

(a) It is claimed that the present shape of top wedge is a source of danger by throwing center of load outside or inside of center of journal, thereby concentrating load on one end or the other, instead of distributing it equally.

(b) A consideration of the general form of box and the present lid, which has not been entirely successful as a dust-proof covering.

(c) Limiting thickness of journal bearings when worn out. "The top surface of the present M. C. B. key is in the shape of a cylindrical segment, the radius of the curve being 78 inches. When the journal box is in its normal position it is in contact with the key at its center, and load which it supports is distributed uniformly lengthwise of the journal. Any necessary adjustment between the box, key and brass by reason of truck imperfections is obtained by a rocking motion of the box on top of the key. It follows that an adjustment obtained in this way necessarily implies an eccentricity of bearing between the box and key, resulting in increasing the unit of pressure at one end of the journal, and to such an extent at times as to seriously interfere with proper lubrication.

"In the examination of trucks that have been in service for some time it will be noticed that a large percentage of the boxes is inclined out of vertical. In most cases it will be found that the tendency of the box is to incline outwardly at the bottom, throwing the load toward the rear of the journal.

"In pedestal type of trucks this condition is very noticeable from the excessive wear which takes place between the pedestals and box guides at top of box. A further evidence of the want of uniformity in the distribution of the load is seen in the unevenly worn bearings, which are removed from time to time. It is well known that the rear end of the journal is the most difficult part of the journal to keep properly lubricated, owing to the tendency of the packing to shift out of position, and also to the amount of grit and sand that is carried in the rear of the box. Add to these obstacles to proper lubrication the excessive bearing pressure at the rear end of brass, and we have a combination at work that sooner or later gives the inspector an opportunity to send in a report of a hot box, resulting from a "doubtful" cause.

"What is desired is a key or brass that will adjust itself to the inequalities of the truck, and at the same time maintain a uniform distribution of the load lengthwise of the journal. This condition cannot be obtained with the use of the present M. C. B. standard key."

In the discussion of the report of the committee on "Care of Journal Boxes," printed in abstract on page 247 of our July issue, Mr. A. M. Waitt made the following remarks:

"I looked up the record on the Lake Shore for the year 1897. Just after receiving that report (and I will say that hot boxes are something we watch closely and have a report on each case, not a hit or miss report, but a report that covers the case of every hot box that requires attention or causes delay to a train on the road) and we average one hot box for every 70,000 miles run. This was on passenger equipment. On freight equipment, with equal care, we had only one hot box in every 20,000 miles run. That result was not obtained without care. Were it not for the foreign cars running over the line which had not received proper care on the home lines, the mileage to a hot box would have been more than four times what it was. On the reports that came in on freight cars 80 per cent. were on foreign cars and 20 per cent. on our own cars. This shows the result of having systematic rules for guidance in the care of journal boxes and in watching the matter closely. If we have an excessive number of hot boxes on any division, as shown by the reports, attention is called to the matter and an explanation asked for. Invariably some good cause will be found for the excess, and that cause is removed and better results occur. I do not think we can have good results in running our journals unless we keep the dust out of the oil boxes. The committee has recommended excluding the dust from the front end of the box, and yet they seem to think that a common wooden dust guard, cut, as most of them are, from 1-16 to 1/8 inch larger than the part of the axle where they fit, will be satisfactory. You will find the waste in the oil box dirtier, more full of grit and sand at the back end than you do at the front end, with the many non-dust tight box covers at the present time. I would not publicly advocate any one dust guard to the exclusion of another. I believe it is worth while, however, to experiment with the many in the market, and find something that will be better than the common, crude dust guard, which is no protection to speak of to the box. I believe if some of the gentlemen who have in their answers advocated the wooden dust guard had experimented with other devices, they would have found some advantages in them. We find it desirable, or most essential as winter comes on, that all of the lighter summer oils used in the oil boxes be entirely removed from the waste. If the summer oils are left in the waste and the winter oil is allowed to mix with the other, as soon as cold weather comes the summer oil will thicken and the fibers of the waste which are filled with the oil will become non-conductors of the oil and the result is that your waste is stiff. The oil will not be fed by the waste to the journal box, and the waste will work away from the under side of the journals and you will have hot boxes. At the time of changing the oils it has been our practice for several years to remove the waste from the journal box and under a press squeeze out the light grade of oil, and put it aside until the following summer. We resaturate the waste with the winter oil, and after it has been saturated a long time, 48 hours or so, repack the box with it. We have found that the results since that practice is adopted have been very satisfactory. An excessive number of hot boxes seem to come right after a thaw, and it was found that when the weather had begun to be moderate there would be a collection of water inside the oil box, and in proportion to the amount of water that seemed to be in there—I suppose the condensation of the atmosphere—seemed to be the lack of lubrication of the journals and the increase of hot boxes. That was overcome by more frequent withdrawal of the packing and removal of the moisture. On some of the fast trains it has been found a wise practice, whenever there has been a moderation in the temperature after severely cold weather, to make sure, before these trains go out, that all of the water has been removed from the waste, and this practice has stopped the annoyance from hot boxes on such trains.

PERSONALS.

Mr. T. M. Downing has resigned as Master Mechanic of the Columbus, Sandusky & Hocking.

Mr. M. F. Bonzano, Superintendent and Chief Engineer of the Columbus, Sandusky & Hocking, has resigned.

Mr. W. R. Ellis has been appointed General Superintendent of the Hegewish shops of the Illinois Car & Equipment Company.

Mr. W. S. Alexander, President and General Manager of the Eastern Railway of Minnesota, a part of the Great Northern, died in St. Paul Sept. 4.

Mr. O. M. Lang, Cashier of the Seattle & International at Seattle, Wash., has assumed the duties of purchasing agent in addition to those of cashier.

Mr. W. A. Stone has been appointed Master Mechanic of the Detroit, Toledo & Milwaukee Railroad, vice, J. W. Witmer, resigned. Headquarters, Marshall, Mich.

Mr. Wilson Eddy, who was Master Mechanic of the Boston & Albany from 1850 to 1881, died at his home in Springfield, Mass., Sept. 2, at the age of 85 years.

Mr. John Foulk has been appointed Master Mechanic of the Litchfield, Carrollton & Western, retaining his present similar position on the Jacksonville & St. Louis.

Mr. Conrad Miller has retired from the Presidency of the Kansas City, Osceola & Southern, owing to the absorption of that road by the St. Louis & San Francisco.

Mr. W. H. Garlock has been appointed Master Mechanic of the White Pass & Yukon Railway, now under construction in Alaska, with headquarters at Seattle, Wash.

Mr. E. W. How has been appointed General Agent of the Interoceanic Railway of Mexico, with headquarters at 29 Broadway, New York, and will also act as Purchasing Agent.

Mr. Frank Brown, assistant to the Purchasing Agent of the Baltimore & Ohio Southwestern, has been appointed Purchasing Agent of that road, with office at Cincinnati, Ohio.

Mr. Frank Cain has been appointed Master Mechanic of the Texarkana & Fort Smith, with authority to perform all duties pertaining to the office of Superintendent of Motive power and Machinery.

Mr. C. M. Stanton, General Manager of the Jacksonville & St. Louis, has been appointed General Superintendent of the Litchfield, Carrollton & Western also, in place of Mr. T. W. Geer, resigned.

Mr. Horace J. Morse resigned as President and Director of the Iowa Central at the annual meeting in Chicago, Sept. 2, and Mr. Robert J. Kimball, of New York, was chosen President to succeed him.

Mr. John W. Shannon, Inspector for the Westinghouse Air Brake Company, with headquarters in Buffalo, died in that city Sept. 10, aged 47 years. Mr. Shannon was connected with this company nearly twenty years.

Mr. Harry W. Frost, who has been General Sales Agent of the Monarch Brake Beam Company, with an office in the Old Colony Building, Chicago, has been made General Manager of that company, with headquarters at Detroit.

Mr. B. F. Bond has been appointed Engineer of Maintenance of Way of the Litchfield, Carrollton & Western, in addition to his duties as Engineer of Maintenance of Way of the Jacksonville & St. Louis. Headquarters, Jacksonville, Ill.

Mr. W. F. Walworth has resigned as President of the York Southern, owing to the reorganizing of that road, and Mr. Lafean of York, Pa., has been chosen to succeed him. Mr. Walworth has been President of the road since 1894.

Mr. B. S. Josselyn on Sept. 1 retired from the position of General Manager of the Kansas City, Osceola & Southern, owing to the transfer of that road to the St. Louis & San Francisco under a lease. Mr. Josselyn has been with the road since Jan. 1, 1893.

Mr. G. A. Gallagher has resigned as Roundhouse Foreman for the Duluth, South Shore & Atlantic Railway at Marquette, Mich., to accept the position of Mechanical Superintendent of the Duluth, Mississippi River & Northern, with headquarters at Swan River, Minn.

J. R. C. Wrenshall has been appointed Acting Division Engineer Maintenance of Way of the Baltimore & Ohio Railroad in charge of the Third Division, which extends from Cumberland to Grafton, vice George L. Hall, resigned. His headquarters will be in Cumberland, Md.

Mr. George R. Morse, heretofore Secretary and Treasurer of the Iowa Central, was chosen Vice-President of that road at the annual meeting in Chicago, Sept. 2, and Mr. S. Seaman Jones was elected Secretary to succeed him. Mr. E. E. Chase has heretofore been Vice-President. Mr. Morse continues as Treasurer.

Mr. B. S. McClellan, Foreman of the Car Building Department of the Illinois Central at New Orleans, La., has accepted the position of Master Car Builder of the Fort Worth & Denver City, with headquarters at Fort Worth, Tex., and is succeeded at New Orleans by Mr. Theodore W. Sloan, formerly located at Indianapolis, Ind.

Mr. C. M. Raymond, President of the Carbon Steel Company, announces that Mr. Nat C. Dean, who has heretofore represented that company and the Fox Pressed Steel Company jointly, has resigned as agent for the latter and will devote his entire attention to the interests of the Carbon Steel Company as Western Sales Agent, with offices in Chicago (1409 Fisher Building) and New York (Havemeyer Building).

Mr. H. R. Hobart, who for twenty-two years has been chief editor of the "Railway Age," has resigned. He has held the position ever since the paper was started, and he carried a large part of the heavy burden in the earlier days. He has many friends who will miss him, and we join them in wishing him success in his new line, which we understand is real estate business. His writings, which were voluminous in so long a newspaper career, are characterized throughout by conscientiousness and honesty. The "Railway Age" owes much of its success to him, and it will not be easy to find a successor as able and as well equipped.

Judge Thomas M. Cooley, who died at his home in Ann Arbor, Mich., Sept. 12, was one of the ablest and best known American jurists. He was born in Attica, New York, in 1824, and began studying law in Palmyra, N. Y., in 1842. In 1843 he moved to Adrian, Mich., where he was admitted to the bar in 1846. He practised law for about two years in Tecumseh, and in 1857 the work of compiling the General Statutes of Michigan was intrusted to him. He was elected a Justice of the

Supreme Court in 1864, and in 1869 was re-elected to fill a term of eight years. In 1868-9 he was Chief Justice, and in 1885 retired permanently from the bench. In 1881 a school of political science was established in the University of Michigan, and he assumed the professorship of Constitutional and Administrative Law. It was in 1882 that Judge Cooley's attention was first directed to the line of work that chiefly occupied him during the later years of his active life. At that time he was asked by the president of the Baltimore & Ohio, the Pennsylvania, Erie and the New York Central Railways to serve on a Board of Arbitration which was to settle the question of "the difference in rates that should exist both eastwardly and westwardly, upon all classes of freight between the several terminal Atlantic ports." Judge Cooley showed such distinguished ability in dealing with the perplexing problems of railway management that in December, 1886, he was appointed by Judge Gresham receiver for that portion of the Wabash Railway within his jurisdiction. When the Interstate Commerce Commission was organized in March, 1887, Judge Cooley was appointed by President Cleveland a member of that body, and it was in connection with its work that he became most generally known throughout the country. Originally appointed for the term of six years, he was elected the first Chairman of the Commission, and remained in that position until the expiration of his term, when he retired because of failing health. His capacity for work was wonderful. Besides his activities in the lines mentioned, he found time to write a number of exhaustive works on difficult legal questions, the first of which appeared in 1868. He was a student, a thinker, a candid, honest and clear writer and speaker, and in many ways was in advance of his time.

BOOKS AND PAMPHLETS.

"Poor's Manual of Railroads, 1898." Published by H. V. and H. W. Poor, 44 Broad St., New York. Price, \$7.50.

The thirty-first annual volume of Poor's Manual contains the usual statistical summaries of the financial affairs and operations of the railroad systems of the United States, Canada and Mexico, and the book is so very well known as to require only the announcement that it is soon to appear. The new edition of the manual is 130 pages larger than the edition for 1897, and covers the statements of about 4,300 corporations having an approximate capitalization and debt of \$16,500,000,000. Of steam railroads there are presented statements of 1,951 companies—1,782 in the United States, 152 in the Dominion of Canada, and 17 in Mexico. The department of city and suburban railways, comprising electric, cable and horse railroads, is covered by 1,187 corporate statements and contains information respecting these important enterprises. During the life of the manual the advance of the railroad interest has been marvelous, the ten years, from 1878 to 1887 inclusive, having been marked by an increase in the railroad mileage of the country of 87 per cent., while during the ten years since the close of 1887, though a period of constantly increasing depression, the increase for the whole United States has been about 24 per cent., the total mileage Jan. 1, 1898, equaling 184,500 miles. In 1895 the total investment was \$11,362,985,080; gross earnings were \$1,105,284,267, equal to 9.7 per cent. on investment, and net earnings, \$327,505,716, or 2.9 per cent. on capital. Compared with 1895, gross earnings of all steam surface railroads (excluding elevated roads in New York, Brooklyn and Chicago) increased in 1896 \$33,236,588, made up by an increase of \$26,639,562 in freight earnings, of \$4,383,517 in passenger earnings and \$2,213,509 in mail, express, and other miscellaneous earnings. The total number of miles of railroad in the United States at the close of 1896 was 182,565; of which 2,025 miles were constructed during the year. The mileage of lines making returns of their share capital and funded and floating debts equaled 181,394, against 179,821 for 1895, the increase being 1,573 miles. In 1896 the tonnage moved on all the railroads of the United States equaled 773,868,716 tons; the tonnage mileage 93,885,853,634 miles, and the earnings therefrom \$770,424,013—equal to 0.821 cent per ton per mile. In the fourteen years from 1882 to 1896, inclusive, the total freight movement of all the railroads of the country reached the enormous aggregate of 1,025,819,107,347 tons hauled one mile. For this service the railroads received as compen-

sation the sum of \$9,370,973,748; but had the average rates that prevailed in 1882 been in force during this period, their earnings from this source would have been \$12,679,124,168, or \$3,308,150,420 in excess of the amount actually received. This enormous sum, averaging over \$236,000,000 per annum, represents the amount saved to the public by the reduction in the charges for hauling freight. It also represents a revenue equivalent to four per cent. per annum upon an investment of nearly \$6,000,000,000. The rapid substitutions of electric traction for animal power may be judged from the fact that since 1891 the number of horses employed in the street railway service has declined 170,275, nearly 90 per cent. The total length of the lines in the United States equals 16,089.87 miles, against 15,956.13 miles in 1896 and 13,176.38 miles in 1895, the latter sum being an increase of 3,514.32 miles over those in operation in 1891, so that in six years there have been built 6,427.81 miles of city and suburban tramway lines.

"The New Roadmaster's Assistant." A manual of reference for those having to do with the permanent way of American railroads. By George H. Palne. Published by "The Railroad Gazette," 32 Park place, New York. Bound in pantasote, pp. 262; illustrated; price, \$1.50.

This book is a successor to the "Roadmaster's Assistant," written by Wm. S. Huntington in 1871 and revised by Charles Latimer in 1877. Its style is concise and direct, bringing the work of these writers up to date for the benefit of practical men. The author modestly refers to the work as a revision of these earlier ones, but it is really more than that, and contains much new matter. It is intended for the engineer, roadmaster and section foreman. The following list of subjects shows the scope: Organization and methods of work, fences, crossings, platforms, water supply, drainage, culverts, trestles and bridge floors, ballast, cross-ties, rails and fastenings, track work, tools, frogs, switches and stands, emergencies, train signals, fixed signals, rules and tables. The arrangement of the subjects, the wide margins and marginal captions for the paragraphs and the excellent engravings are good features, the engravings being remarkably good. They are from drawings made especially for the book, and we commend them as models to those who illustrate books of this character. We cannot say as much for the printing of some of them. The author gives a deal of tabular matter in connection with frogs, switches and curves. These tables, we believe, were worked out with great care by the author, with a view of assuring their reliability. The book is practical and, probably because of lack of space, contains little of what might be called abstract theory. We find in the chapter on fixed signals one of the best general presentations of the subject that we have seen. It gives a great deal of information about signals that track men do not usually know and yet must know if they are to do their part in signal maintenance. We recommend the book as a good reference work, and we are glad to have a copy for consultation on the many questions that continually arise about track matters. Its greatest value is for roadmasters and engineers of maintenance of way. The book is worthy of a better binding and better lettering; these features are not in keeping with its character in other directions.

"A Pocket Book for Mechanical Engineers." By David Allen Low, M. I. M. E., Professor of Engineering, East London Technical College, London, New York and Bombay: Longmas, Green & Co.; 4 by 6 inches; 740 pages, over 1,000 illustrations and complete Index. Price, \$2.50.

Next to Kent's pocket book the one under review is the best that we have seen. It is particularly strong in the tabular matter and machine details. The tables are numerous and convenient and many are new. They may be used with confidence because the author states in the preface that both those that have been copied from other works and the new ones, of which there are many, have been carefully checked by two persons working independently. The engravings, most of which illustrate machine details, are clear, and the text is very concise. The book records a number of tests and experiments, some of them being taken from the proceedings of well-known societies, and these are valuable additions when put into such a convenient form. Considerable space is given to locomotive details, and boilers for locomotives, stationary and marine service. The arrangement of the work is good, it is well printed and serviceably bound. An impression of reliability and thoroughness is made at the first examination

and it grows as the book is used. Every designer and draftsman should own it. The New York address of the publishers is 91 Fifth avenue.

"Practice and Theory of the Injector," by Sirickland L. Kneass, C. E., Member A. S. M. E. Second edition. New York, John Wiley & Sons, 1898.

To those who have copies of the first edition of this work it is sufficient to say that it has been improved, enlarged and brought up to date. To those who do not know the book it is enough to say that it is the only satisfactory work on the injector. Mr. Kneass is good authority on the subject, and has presented the historical, theoretical and practical sides without going into useless depths of mathematics. The work is strong in results of practical tests and in methods of testing. The concluding chapter is devoted to the care of injectors and their use on locomotives.

"American Street Railway Directory." First Volume, No. 1. Published quarterly by E. L. Powers, New York and Chicago.

This is the first volume of a directory of officials, equipment, power and finance of the United States and Canada. It is standard size (6 by 9 inches), and has 90 pages of classified information pertaining to street railways. It also presents a summary of the street railways of the country. It will be very convenient for those who transact business with these roads.

"Report of the Proceedings of the Thirty-first Annual Convention of the American Railway Master Mechanics' Association Held at Saratoga, N. Y., June, 1898."

The proceedings of this organization are too well known to require special comment, except upon their prompt appearance. The volume reached us less than seventy days after the convention, and considering the vast amount of labor necessary to get the matter ready for the press, this is extraordinary. The volume is in the usual form.

Lectures at Purdue University.—We have received a number of pamphlets containing the lectures of men in successful business life that were delivered before the students of Purdue University during the year 1897-98. There were eleven lectures, all but two being put on record in these pamphlets. The subjects are as follows: "Problems in the Management of a Railroad System," by Mr. J. T. Brooks, Second Vice-President, Pennsylvania Lines West of Pittsburgh; "The Past, Present and Future of American Railroads," by Mr. M. E. Ingalls, President of the Cleveland, Cincinnati, Chicago & St. Louis; "The Mutual Obligations of Railroad Corporations and the Public," by Mr. John W. Noble, ex-Secretary of Interior; "Relation of Railroads to the State," "Railroads and the People" and "Railroads and Their Servants," the three by Mr. Addison C. Harris, Attorney at Law; "Business Problems of the Motive Power Department," by Mr. Robert Quayle, Superintendent of Motive Power, Chicago & Northwestern; "Railroad Signaling," by Mr. F. A. Delano, Superintendent of Freight Terminals, Chicago, Burlington & Quincy; "Car Designing and Construction," by Mr. A. M. Waitt, General Master Car Builder, Lake Shore & Michigan Southern. We understand that copies of the pamphlets may be had on application to the Secretary of Purdue University, Lafayette, Indiana.

"Protective Coatings for Iron and Steel." This is a 15-page pamphlet by W. W. Lawrence & Company, Pittsburgh and Buffalo.

The importance of protective coatings and the differences of opinion among authorities as to the best methods to be adopted are first pointed out and the pamphlet in clear, concise language, gives statements in regard to the following subjects: 1. The manner in which paints on metal surfaces fail. 2. The causes for such failures. 3. The qualities required in a successful protective coating. 4. How these qualities are secured in the use of the permanent paints furnished by this company. The main part of the pamphlet is valuable entirely aside from the fourth subject just mentioned and is worthy of preservation for its clear treatment of the general problem of preservation, and the application of the premises to the product of these manufacturers is equally clear. Paints usually fail by powdering, peeling and blistering and by cracking. The causes are improper condition of surface, improper materials in the paint, improper binding material, improper shop methods and causes which lie outside of the materials and methods used. The opinion of the authors is supported in many of the statements by quotations from well-known authorities.

One weakness in most paints not generally understood is the presence of minute pores which only the microscope reveals, and these cause rapid deterioration by permitting the absorption of water, which is the most general and most powerful influence in destruction of metallic structures. The text says: "Hence we say that the successful protective coating for iron must not be porous but present instead a glossy enamel-like surface that will effectually prevent absorption of moisture." The effects of galvanic action, of waste by gaseous action and heat are also noted. A little more than half the space is entirely free from references to the Lawrence paints, and the application of the principles is then stated logically and plainly. The basis for these paints is red lead and the objections to this type of paints are reviewed and met by statements as to how the objections have been overcome in the manufacture of the "Permanent Paints." The "Lawrence Asphaltic Bridge Conservative" is one of the paints described. This coating is prepared in accordance with a formula by Dr. C. B. Dudley, chemist of the Pennsylvania Railroad, and a frequent contributor to the "American Engineer" on paints and other subjects. The special qualifications for protecting surfaces primed with "Lawrence's Permanent Paints" are stated, after which attention is given to the materials used in these paints, and the pamphlet closes with brief specifications recommending their use in first, second and third coats.

"Painting on Metal, with Specifications." By A. H. Sabin. Published by Edward Smith & Co., 45 Broadway, N. Y.

This is a little book of 84 pages printed primarily to interest people in the product of the publishers. The work is divided into four parts or chapters, the first of which is introductory and treats of the general principles of protection of metallic surfaces. The second gives a set of specifications for high-grade work such as important bridges and permanent construction work. The third presents specifications for what is termed ordinary work, not requiring a sand blast preparation. These specifications were carefully prepared with the aid and suggestion of a number of prominent engineers. The "Durable Metal Coating" is too prominently mentioned in the specifications to give any idea of disinterestedness. At the end of the book is a chapter on this paint and the claims made for it. The book is expensively gotten up and contains a great deal of valuable information and a number of excellent engravings. It is bound in leather and is worthy of preservation.

The New Britain Machine Company, New Britain, Conn., have sent us catalogues of Case Steam Engines and Chain Saw Mortisers. Both of these are standard size, and are unusually complete in the information given concerning these products, the sizes of the machines, floor space occupied and other data necessary in purchasing being given. The Case engines are shown in large variety, with pedestals and wall brackets and hangers, with throttling and automatic cut-off governors. They may be mounted on the floor, on a floor foundation, on the side of a wall, or they may be suspended from the under side of an overhead beam. These engines are inclosed, and are very neat and compact and light. They have large wearing surfaces, automatic lubrication and good regulation, the design being made specially with reference to high speed, little wear, low cost for repairs and long life. The reciprocating parts of an eight horse power engine weigh 11 pounds, one-half of which is counterbalanced by the crank. The manufacturing facilities of the builders are excellent, and those desiring small steam powers for machinery or direct connection to electric generators or fans will do well to send for the catalogue. The chain saw mortisers are described as fully as the engines. The mortise is made by a steel chain, each link of which has a sharpened tooth formed to carry out its own chip. The chain travels about 1,500 feet per minute, and the cutting is clean and very rapid. The chips are sucked away by a fan, driven by the sprocket that drives the chain. The output is high, on door work users report cutting from 80 to 120 door stiles per hour, other work being in proportion. The special claims made are given in detail in the pamphlet, together with statements of capacities and dimensions of each style and size of machine. We should say that the larger sizes of these machines would be valuable in car work. This concern has a large domestic and foreign trade in engines and the chain mortisers. They have also supplied them to the United States Government.

"The Lake Shore Limited."—An advance copy of an illustrated booklet, descriptive of "The Lake Shore Limited," the new twenty-four hour train between New York, Boston, Cleveland and Chicago, via the New York Central, Boston & Albany, and Lake Shore Railroads, has been received from Mr. Geo. H. Daniels, General Passenger Agent of the New York Central. This booklet is from the press of the American Bank Note Company, and, in addition to new illustrations and a brief description of the cars and their appointments, a map of the route, and time tables, it contains a feature not heretofore made use of in railroad advertising, which is a descriptive time table, detailing in concise language the principal objects of interest that may be seen from the observation car from time to time as the train progresses on its daily journey. For instance, each river is named, and the reader is told where it rises and where it empties, he is informed what railroad he crosses, the name of the towns passed. The illustrations show the interior of this magnificent train. A copy can be obtained by application to Mr. Daniels, addressed Grand Central Station, New York.

The Joseph Dixon Crucible Co., Jersey City, N. J., has just issued a little pamphlet, entitled "Helps in Brazing." It treats incidentally of brazing graphite, the application of which to bicycle tubes prevents the adherence of the spelter and so effects a saving in labor by making unnecessary the filing which is otherwise needful. The pamphlet, however, especially treats of the process of brazing by the dipping method, or "liquid brazing," as it is called. The brazing crucible is described, together with instruction and caution in regard to its use. Instructions are given how to build and set the necessary furnace, time required for brazing, etc. The pamphlet will interest all who have brazing to do, and it will be sent upon application.

"What They Think of the New Baltimore & Ohio Railroad."—This title is borne by a pamphlet recently issued from the office of Mr. J. H. Maddy, Press Agent of the B. & O., at Baltimore. It is illustrated with excellent and striking half-tone engravings of the improvements made on this line, and contains reprints of articles written by newspaper men after several daylight rides over the line during the first week in July. The pamphlet will convince the reader that this road has greatly improved under the present management. The engineering work in improving the line has been carried out on a very broad and liberal scale, the efforts being specially directed toward improving the operating conditions for the benefit of the stockholders.

"Hunt Automatic Railway."—This catalogue, issued by the C. W. Hunt Company, 45 Broadway, New York, is known as No. 9,806. It illustrates and describes the railway equipment manufactured by this firm for the purpose of handling coal ore, merchandise and loose material in general. Half tone engravings and line drawings illustrate the appliances and methods used for the handling of material by railways. Those who have not studied the excellent methods of manufacture of these appliances will be interested by the pamphlet, and all who have the handling of coal or similar material should procure it.

The "U. S. S. Oregon" is the subject of an attractive advertisement in colors, recently received from the Peerless Rubber Manufacturing Co., 16 Warren street, New York. The purpose of the engraving, 14x20 inches in size, is to direct attention to the fact that the use of "Rainbow Packing" in all of the packing joints, piston and valve rods on this fine ship contributed to her wonderful performances during the war with Spain. We have directed attention to her continuous run of over 13,000 knots, and her burst of speed at Santiago. There is no doubt of the value of such details as good packing as leading to the unparalleled achievements of this ship. A copy of the picture may be obtained by every engineer on application to this company.

The J. G. Brill Company, Philadelphia, has issued a pamphlet, dated September, 1898, in which the new "Dedenda Gong" is illustrated and described. This is a new mechanism for operating gongs on street cars, which is a great improvement upon the devices generally used. The plunger, or treadle, has a large head, so arranged as to lock down flush with the floor when not in use. The whole arrangement is self-contained, and

may be attached by any carpenter. The details have been worked out to make the sounding of the gong clear and the mechanism very simple.

"A Quarter Million Horse Power of Polyphase Electrical Transmission Apparatus."—This is the title of a pamphlet received from the Westinghouse Electric & Manufacturing Company of Pittsburgh. The pamphlet contains data in regard to 185 electric power plants distributed through 29 states and eight foreign countries. The distances through which transmission is carried range between one and 78 miles. The pamphlet illustrates the largest work of this concern at Niagara Falls by means of handsomely executed engravings.

"The Hunt Cable Railway for Handling Coal and Merchandise," is the title of a 20-page illustrated pamphlet received from the C. W. Hunt Co., 45 Broadway, New York. It describes, with the aid of half tone engravings, a number of large coal and merchandise handling plants built and installed by this company of engineers and gives a great deal of information of value to those who have to do with the transportation and handling of loose material. The catalogue is known as No. 9,803.

The San Francisco Bridge Company and New York Dredging Company have sent us a copy of an illustrated pamphlet showing a number of examples of heavy and important engineering and dredging works carried out by them. The pamphlet is a partial record of their undertakings, many of which are well known. The office of the Bridge Company is 42 Market street, San Francisco, and of the dredging company, World Building, New York.

PRATT INSTITUTE TWO YEAR COURSES.

Mr. Arthur L. Williston, Director of the Department of Science and Technology of Pratt Institute, Brooklyn, has sent us circulars describing the newly-inaugurated two year courses of that institution. They are not intended to take the place of elaborate four year courses, involving a large amount of preparation, but rather to prepare students in a short time in mechanical electrical subjects, so that they may take places of responsibility in these lines if they cannot afford the time for more extended courses.

Drawing, machine design and applied electricity are covered in the two years work. The drawing includes projection, intersections, mechanism, and finally machine design. Shop work, study of iron and steel manufacture and strength of materials follows the drawing. In applied electricity the course covers physics, heat and laboratory practice in the use of electrical machinery.

Particulars of the courses may be obtained from the Secretary of Pratt Institute, Brooklyn, N. Y.

EQUIPMENT AND MANUFACTURING NOTES.

At the shops of the Rock Island, in Horton, Kan., recently, the work of erecting an engine was completed in 7 hours and 15 minutes from the time that the boiler was received.

Simplex body and truck bolsters, manufactured by the Simplex Railway Appliance Co., the Fisher Building, Chicago, were specified for 300 flat bottom coal cars for the Southern Railway recently.

The Louisville & Nashville has been obliged to provide its north and south division with ten additional engines in order to take care of the heavy freight business that is now being done.

During the past two years the receivers of the Baltimore & Ohio Railroad have increased the yard and siding facilities to the extent of 102.46 miles on the lines east of the Ohio River. While a great deal of this mileage is addition to the yard room, a very large number of short side tracks were laid for the benefit of industries along the line.

The Westinghouse Electric & Manufacturing Company of Pittsburgh and the Walker Company of Cleveland have consolidated, the Westinghouse capital stock being \$15,000,000 and that of the Walker Company \$2,500,000. The street railway business is now controlled by this combination and the General Electric Company.

Westinghouse electro-pneumatic interlocking apparatus is being put in at Whitechapel, London, on the Great Eastern Railway.

The Chicago Pneumatic Tool Co. has received orders for 36 pneumatic tools and 3 air compressors to go to Japan. A second order for riveters, hammers and drills has been received from the Imperial Chinese Railway, and these, with many home orders, including machines for the United States navy yards, keeps the concern exceedingly busy.

The Q & C Company have an interesting exhibit at the Trans-Mississippi Exposition at Omaha, which is attracting a great deal of attention. It is under the charge of Mr. Jesse Whittall, and we are informed that a number of orders have been received from persons who have seen it. The specialties known under the designation "Q & C" are as follows: Brake shoe keys, journal box lds, shop saws, freight car doors with Wood's seal lock, pneumatic oil distribution system, Scott boiler feeder and Stanwood car steps, besides which the exhibit includes Bryant rail saws, compound lever jacks and the Servis tie plate.

There has been a great deal said in newspapers lately about the discontinuance of "The Lake Short, Limited," the New York Central's twenty-four hour train between New York and Chicago. There is no truth in this rumor. We are informed that "The Lake Shore, Limited," will continue to run every day in the year over the New York Central & Hudson River and Lake Shore & Michigan Southern Railroads—the same tracks that carried the Exposition Flyer, between New York and Chicago, in twenty hours, for 175 days during the World's Fair.

The incorporation of the Federal Steel Company, September 9, under the laws of New Jersey, with capital stock of \$200,000, is an event the whole meaning of which can not now be appreciated or even stated. The company has power to do almost all kinds of business in any part of the world, and its influence on the manufacture of iron and the interests involved therein may be expected to be a powerful one. The incorporating companies are: The Illinois Steel Co., the Minnesota Steel Co., the Elgin, Joliet & Western Railway, the Lorain Steel Co., and the Johnson Steel Co. It is reported that the Carnegie interest is included, but this is not known at this time.

The Holland Company, Pittsburgh, has issued an illustrated descriptive circular of their facilities and methods of renewing and rerolling steel rails. The renewing process is to cut off the worn ends of rails and re-drill them for the angle bars, and the rails are sorted according to the heights to which they are worn for convenience in relaying. The salvage from the worn ends is applied to the cost of renewing. When orders are large enough, they are prepared to move the plant to the works to save expense in transportation. A plant has been built at Wheatland, Pa., and orders are now on hand to keep it busy for a long time.

Col. W. H. Powell of the Ninth Infantry, United States Army, has addressed a letter to the passenger department of the New York Central, in which he said: "It is with great pleasure that I take the earliest opportunity to acknowledge the courtesy and consideration shown my command in its recent trip over the New York Central by every official of the road. I have been traveling with troops over railroads off and on for some thirty-seven years, and I do not hesitate to say that the most comfortable and rapid trip I ever made in all these years is the trip over your road, which you were so kind as to personally supervise."

A telephone experiment is to be tried upon the Baltimore & Ohio that will involve using the telephone for long distance communication. Work will begin in a few days on the construction of the new copper telegraph lines between Baltimore and Pittsburg, 340 miles, and they will be so arranged that when the necessity arises they will be available for telephonic communication. One of the wires will be extended as far as Newark for telegraphic use. A new line has also been constructed between Columbus and Cincinnati. It will take 800 miles of copper wire, weighing 166 lbs. to the mile, to complete the work.

The experiment of the Illinois Central to induce its employees to invest in the stock of the company seems to have proved a greater success than the company expected. The men have bought freely, and no one hears of dissatisfaction among them in regard to wages or other cause of grievance.

Mr. Francis R. F. Brown, M. I. M. E., formerly Mechanical Superintendent of the Intercolonial Railway of Canada, has opened an office as Consulting Mechanical Engineer at 22 Street Railway Chambers, 574 Craig street, Montreal. He will make a specialty of inquiries, assessing fire losses of machinery and plants and general mechanical engineering business. Mr. Brown's extensive experience qualifies him admirably for professional work of the highest character.

The Westinghouse Machine Company very generously tendered a banquet to the members of the National Association of Stationary Engineers attending the seventh annual convention at Pittsburgh, September 17, and opened their works for inspection by the visitors. The visit was interesting and instructive, and was thoroughly enjoyed. Among the features of interest was the large 750 H. P. Westinghouse gas engine in operation. The opportunity to see these works is an unusual one, which was appreciated. The plan of enabling men who run and care for engines to see the process of construction is commendable. About 600 visitors took advantage of the opportunity.

Pictures of two interesting Baltimore & Ohio Railroad buildings have been reproduced in a recent issue of "Truth." One is the building at Frederick, Md., which has been used since 1831 as a freight station, and which is still devoted to that purpose. In the little cupola of the building a bell once hung which was always rung on arrival of trains from Baltimore when horses were the motive power of the railroad. The other building is the station at Mount Clare, Baltimore, and it is noted as being the location of the first telegraph office in the world. It was from this building that Prof. Morse sent his celebrated message in 1844 to his friends in Washington, forty miles away.

The Westinghouse Electric & Manufacturing Company has taken a contract for machinery to go to China. Consul Ragsdale of Tientsin, under date of July 9, 1898, speaking of the arrival of the new United States Minister, Mr. Conger, mentions the general popularity of Americans in China. Expressions of friendship for our people, he says, are heard in official and business circles. He notes a contract just made by a representative of the Government with Mr. Diferderfer of Philadelphia, for the purchase of all machinery necessary to establish an up-to-date woolen mill at Tientsin. The electric machinery will come from the Westinghouse Electric Company of Pittsburgh, the boilers and engines from the Harrisburg Foundry & Machine Company, and the remaining machinery from the James Smith Woolen Machine Company of Philadelphia.

Purdue University entered upon the work of a new term Sept. 14 under conditions favorable to an excellent year's work. The engineering laboratory has, during the summer, been supplemented by the addition of a room 50 by 100 feet, known as the "Railroad Laboratory." In this room the equipment of machines for testing strength of materials and the brake shoe testing machine of the Master Car Builders' Association are already in place. There is also a fine full-sized model of the front end of a Richmond compound locomotive and an exhibit of typical steel car trucks. The equipment of this room will be completed during the Fall by the installation of the air brake testing rack of the Master Car Builders' Association. The number of students matriculating for the new year is larger than for several years past. The freshman class will number about two hundred, nearly two-thirds of whom are in the engineering courses. There are but few changes in the corps of instructors in the engineering department. Mr. Leopold O. Dancer, for several years Senior Instructor in Mechanical Engineering, Lehigh University, has been appointed an instructor in machine design, and Mr. Robert S. Miller, assistant in the engineering laboratory, has been made instructor in the mechanics of machinery.

OUR DIRECTORY

OF OFFICIAL CHANGES IN SEPTEMBER.

Baltimore & Ohio.—Mr. J. R. C. Wrenshall has been appointed Acting Division Engineer Maintenance of Way, vice Mr. George F. Hall, resigned. His headquarters will be in Cumberland, Md.

Baltimore & Ohio, Southwestern.—Mr. Frank Brown has been appointed Purchasing Agent, with office at Cincinnati, Ohio.

Beaver Meadow, Treseckow & Boston.—Mr. Israel Platt Pardee has been elected President, vice A. S. Van Wickle, resigned.

Columbus, Sandusky & Hocking.—Mr. T. M. Downing has resigned as Master Mechanic, and the duties of the office will be assumed by the Superintendent.

Columbus, Sandusky & Hocking.—Mr. M. F. Bonzano, Superintendent and Chief Engineer, has resigned.

Columbus, Ohio River & Tidewater.—Mr. William Kirkby of Toledo, President of this road, has resigned in order to become a member of the construction company. Mr. L. H. Altimus of Ripley, Ohio, has been elected President to succeed him.

Chicago Junction.—Mr. J. B. Cox has been appointed Chief Engineer, with office at Chicago, Ill., vice Mr. C. W. Hotchkiss.

Central Ontario.—Mr. H. S. Johnson has been elected Vice-President, vice Mr. H. P. McIntosh of Cleveland, Ohio.

Detroit, Toledo & Milwaukee.—Mr. W. A. Stone has been appointed Master Mechanic, vice Mr. J. W. Witmer, resigned.

Duluth, Mississippi River & Northern.—Mr. G. A. Gallagher has been appointed Mechanical Superintendent, with headquarters at Swan River, Minn.

Fall Brook.—Mr. Daniel Beach has been chosen First Vice-President, to succeed John Lang, deceased, and Mr. John H. Lang has been elected Second Vice-President. Mr. Wm. Howell has been made Assistant Treasurer.

Fort Worth & Denver City.—Mr. B. S. McClellan has been appointed Master Car Builder, with headquarters at Fort Worth, Tex.

Galveston, La Porte & Houston.—Mr. T. W. House has been appointed Sole Receiver of this company on account of the death of Mr. M. T. Jones.

Georgia & Alabama.—Mr. E. E. Anderson, heretofore Train Master, has been appointed Purchasing Agent and Assistant to General Manager Gabbett at Savannah, Ga.

Illinois Central.—Mr. L. A. Washington, heretofore Assistant Superintendent of the Evansville District of the Louisville Division, with headquarters at Evansville, has been appointed Assistant Engineer of the Louisville Division, with headquarters at Henderson, Ky.

Interoceanic Railway of Mexico.—Mr. E. W. How has been appointed General Agent, with headquarters at 29 Broadway, New York, and will also act as Purchasing Agent.

Iowa Central.—Mr. Robert J. Kimball has been chosen President, to succeed Mr. Horace J. Morse, resigned. Mr. Geo. R. Morse has been chosen Vice-President.

Kansas City, Osceola & Southern.—Mr. B. S. Josselyn has retired from the position of General Manager, owing to the transfer of that road to the St. Louis & San Francisco. Mr. Conrad Miller has retired from the Presidency, for the same reason.

Litchfield, Carrollton & Western.—Mr. C. M. Stanton has been appointed General Superintendent, in place of Mr. T. W. Geer, resigned. Mr. John Foulk has been appointed Master Mechanic, retaining his present similar position on the Jacksonville & St. Louis. Mr. B. F. Bond has been appointed Engineer of Maintenance of Way, in addition to his duties as Engineer of Maintenance of Way of the Jacksonville & St. Louis; headquarters at Jacksonville, Ill.

Southern Indiana.—Mr. F. B. Ogden has been elected Vice-President, with office at Chicago, Ill.

Seattle & International.—Mr. O. M. Laing has assumed the duties of Purchasing Agent, in addition to those of Cashier.

Spokane Falls & Northern.—Mr. A. Jackson has been appointed Resident Engineer, with headquarters at Spokane, Wash., in place of Mr. E. J. Roberts, Chief Engineer, resigned.

Texarkana & Fort Smith.—Mr. Frank Cain has been appointed Master Mechanic, and will perform all duties pertaining to the office of Superintendent of Motive Power.

Wabash.—Mr. W. A. Bell has been appointed Master Mechanic of the Wabash Terminals in Chicago.

White Pass & Yukon.—Mr. W. H. Garlock has been appointed Master Mechanic, with headquarters at Seattle, Wash. The road is now under construction in Alaska.

York Southern.—Mr. W. F. Walworth has resigned as President, and Mr. Lafean, of York, Pa., has been chosen to succeed him.

WANTED.

Back volumes of the "American Engineer and Railroad Journal" and the "American Railroad Journal," especially 1842, 1867, 1882 and 1889. Address "N. S. B.," Room 1214, 40 Exchange Place, New York City.

AMERICAN ENGINEER CAR BUILDER AND RAILROAD JOURNAL.

NOVEMBER, 1898.

CONTENTS.

ILLUSTRATED ARTICLES:	Page	MISCELLANEOUS ARTICLES:	Page
Construction of Modern Locomotive.....	357	Breakage of Piston Rods.....	369
Hayes Ten-Wheel Locomotive.....	361	Locomotive Grates.....	369
New Schenectady Mogul, N. Y. Central.....	362	Long Burlington Train.....	370
Consolidation Locomotive, Union Ry.....	365	Anti-Scalping Movement.....	371
Locomotive Design, Piston Rods.....	366	Engineering Notes.....	374
Breakage of Piston Rods.....	369	Rolling Stock in the United States.....	375
Body and Truck Bolsters.....	370	American Ry. Assn. and Metric System.....	377
Locomotive Staybolts.....	371	Electric Car Lighting.....	378
Metallic Rod Packing.....	376	What Railroad Clubs Might Do.....	380
Flexible Steam Heat Conduit.....	376	The Thermal Car Wheel Test.....	380
Chilled Wheels for 100,000 lbs. Cars.....	376	Consolidation M. M. and M. C. B. Associations.....	381
Pneumatic Riveting on Largo Scale.....	378	Salt Water Drippings on Bridges.....	382
Aeme Triple Bolt Cutter.....	379	Gas and Gasoline Engines for Pumping.....	382
Ten-wheel Freight Locomotive, Mo. P. Ry.....	381		
Air-Hose Failures.....	382	EDITORIALS:	
		The Dummy Coupler.....	372
MISCELLANEOUS ARTICLES:		The Metric System in Russia.....	372
Metric System in Russia.....	368	Must the Distant Signal Go?.....	372
The Dummy Coupling.....	368	Steel for Axles, Crank Pins and Piston Rods.....	372
		Adjustment of Prices of Car Repairs.....	373

THE CONSTRUCTION OF A MODERN LOCOMOTIVE.*

By T. R. Browne,
Master Mechanic, Juniata Shops, P. R. R.

VI.

Erecting Shop.

To the reader of preceding articles in this series it is apparent that the description of operations performed in the various departments, taken collectively, indicate a steady progress toward the complete engine and a systematic delivery of all of the various parts required in its final erection in the erecting shop. Some idea of the immense amount of detail in the modern locomotive may be formed when we state that the average modern engine contains approximately 20,000 separate and distinct pieces, and of this total number 13,600 pieces, approximately, are handled, fitted and formed into parts for use in the erecting shop by the various other departments throughout the plant, and the balance, or 6,400 pieces, are handled in the process of actual erection in the erecting shop. We have previously, and wish to again emphasize, the importance of considering the erecting shop only as a place where actual erecting is done, that is to say, it is not equipped with machinery except that required for the lifting and handling of the various parts and the equipment necessary in the operations of erecting, and no machine work of any kind is performed in this department except the drilling of certain holes which can only be done in erecting and the reaming incident to the use of taper bolts. The concentration of the manufacture of all of the parts of the locomotive in other departments than the erecting shop, and the consequent necessity that these parts when delivered shall be accurate in every respect, places the erecting department in the position of general inspector of the output furnished from other departments to it, and under the supervision of a careful and intelligent foreman the advantages of this will be obvious. Following the schedule referred to in previous articles indicating the order in which each part or group of parts will be required by the erecting shop, continuous and uninterrupted erection in this department is possible,

and for better illustration of the various stages leading to completion of a modern locomotive the accompanying photographs selected for the purpose of illustrating an average case and taken at intervals of ten hours will graphically illustrate the various stages of erection.

Figures 1 and 2 indicate respectively the boiler schedule "A" and the frames schedule "B," with the various parts ready to be fitted to them. These are all of the parts required in this particular stage of the operation or on this schedule. The placing or erecting of the parts shown in Figs. 1 and 2 is performed by separate gangs of men, and these two operations are carried on simultaneously. Figs. 3, 4 and 5 illustrate the condition of erection at a period 10 hours later than the condition illustrated in Figs. 1 and 2, and during which time the parts shown in Figs. 1 and 2 have been attached and connected, the frames placed on the pit and the boiler lowered on the frames as shown in Fig. 6, in which condition the further erection included in schedule "E" is commenced. It will be recalled that the schedule sheet for ordering and turning out the various parts is divided into six grand divisions and designated by the letters "A," "B," "C," "D," "E" and "F," in which schedule "A" includes the boiler with all of the necessary attachments and parts as shown in Fig. 1; schedule "B" the frames with their various parts and attachments as shown in Fig. 2; letter "C" the wheel and engine truck work, complete parts for which are furnished by the machine shop; letter "D" tank and tender work; letter "E" the general erection and completion, the beginning of which is illustrated in Fig. 5, and letter "F" final test and inspection. Fig. 7 illustrates the condition of erection at a period of 20 hours later than that illustrated by Figs. 1 and 2, and 10 hours later than its condition illustrated in Fig. 5, during which time all of the various valves and attachments, including steam pipes, etc., necessary for the preparation of the boiler for test have been put on and connected, and the boiler given a water and steam test.

Figs. 7 and 8 illustrate two views of the erection during this period, and in which the boiler is shown in the process of receiving a steam test. It will be noticed in Fig. 8 that the steam is blowing off, the maximum pressure required having been reached. This testing is done with fuel oil, which is burned by means of a burner attached to an ordinary fire door provided with a special gas generating nozzle illustrated in Figs. 9 and 10, compressed air being used for atomizing the oil and creating the necessary amount of pressure for feeding the oil to the burner. The oil tank is mounted on a pair of wheels for convenience of moving to various parts of the shop where testing may be necessary, and the connections, both for air and oil, from this tank to the burner are made with ordinary air hose. In making the test in this way the boiler, after being filled to the proper water line, is charged with steam from the stationary plant to a pressure of from 50 to 60 pounds, and the oil burner is then started and the test completed in about three-quarters of an hour. The flame from the oil burner, owing to the peculiar construction of the burner, is practically a gas flame, and no free oil is discharged into the fire box; the flame of gas formed by the burner burning in the form of a large brush on the inside of the fire box. It has not been found necessary to make any provision for fire brick or insertion of any special appliance on the inside of the fire box for this operation.

All of the air pumps, before being placed in service, are carefully tested under steam, and the output from these pumps, while being tested, has been found sufficient to not only furnish the required amount of compressed air for operating the burners for testing boilers, but also the large number of pneumatic hammers, drilling and reaming machines used throughout the shop in the various operations of erecting. A convenient form of mounting four of these air pumps for test is so arranged that they can be removed from time to time at the completion of test and others put in their places without disturbing an unnecessary amount of piping.

*For previous article see page 329.



Fig. 1.

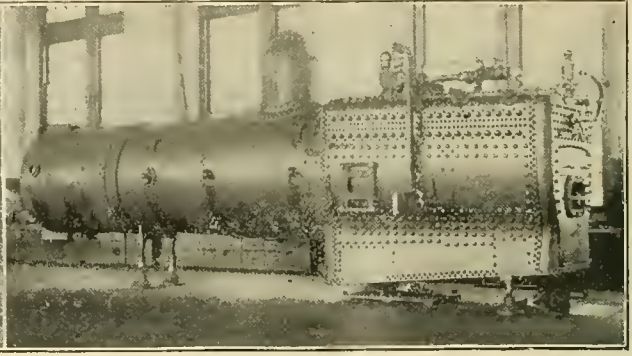

Fig. 4.



Fig. 2.

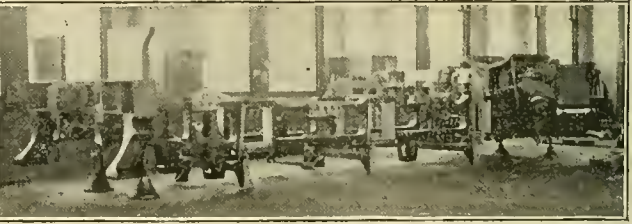

Fig. 3.



Fig. 5.



Fig. 6.

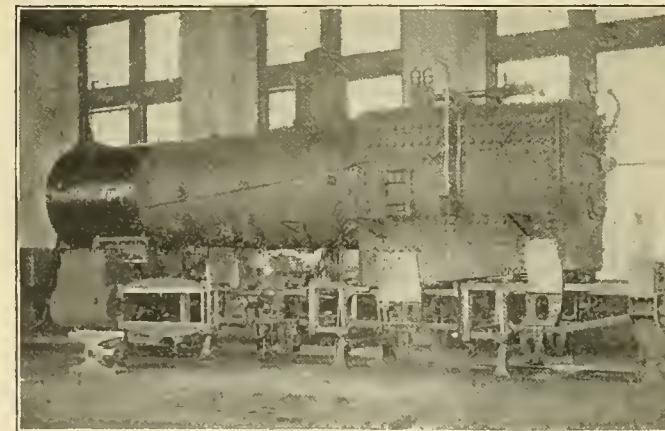

Fig. 7.

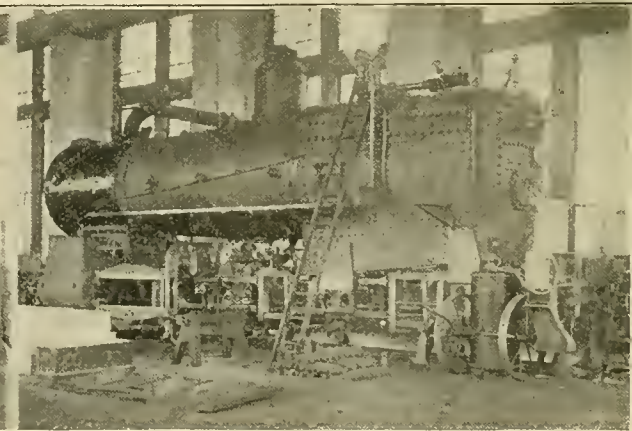

Fig. 8.

CONSTRUCTION OF A MODERN LOCOMOTIVE—THE ERECTING SHOP.

By T. R. BROWNE.

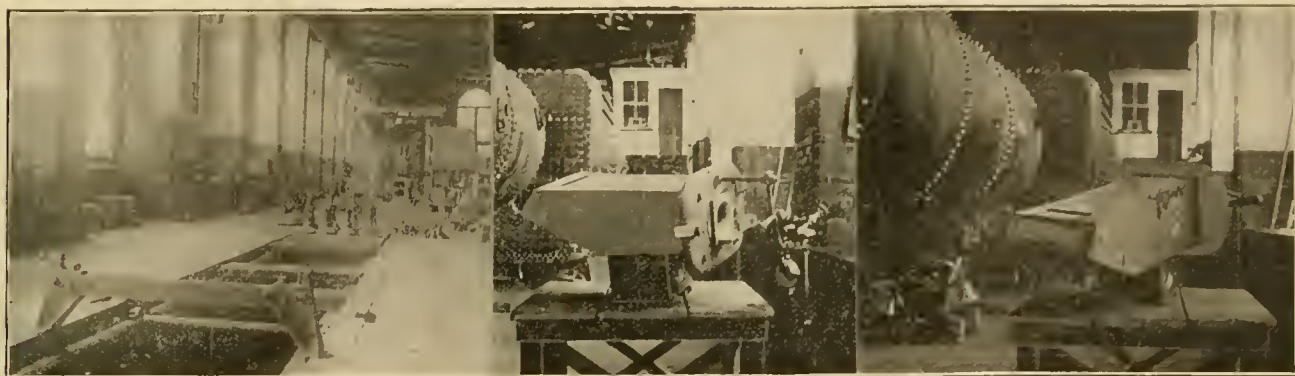

Fig. 11.

Fig. 9.

Fig. 10.

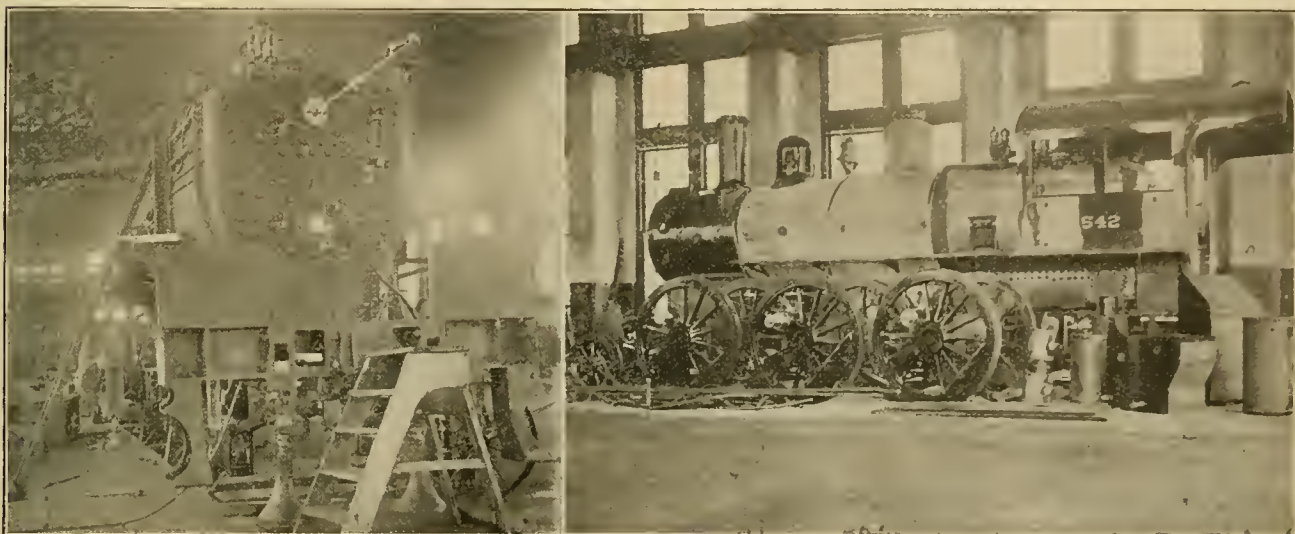

Fig. 12.

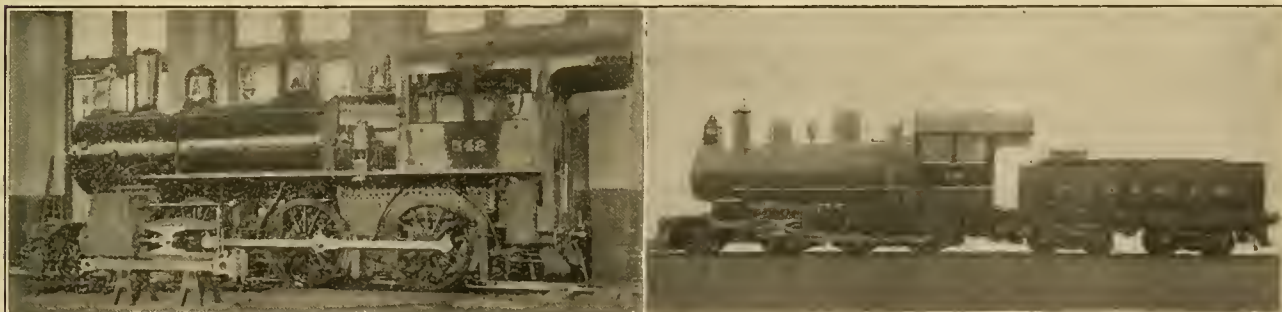

Fig. 13.

Fig. 14.

CONSTRUCTION OF A MODERN LOCOMOTIVE—THE ERECTING SHOP.

BY T. R. BROWNE.

They are placed in the four corners of a square, which renders the piping very convenient and compact. In cold weather it has been found convenient to use the exhaust from these air pumps for heating the shop.

Considered from the standpoint of safety and uncertainty as to maintenance of proper alignment, the use of wooden blocking necessary and usually used in the operations of erecting shown in Figs. 2 and 5, has made advisable the adoption of a device similar to that illustrated in Fig. 11, which is provided with two adjustments for vertical and side alignment, and arranged to be either used on the pit or on the floor.

Fig. 12 illustrates the condition of erection on schedule "E" 30 hours later than the condition illustrated in Figs. 1 and 2, and 10 hours later than the condition illustrated in Figs. 6, 7

and 8, during which time two additional steam tests have been applied, the lagging put on and jacket partially completed, together with other work, as will be clearly noted in the illustration. Fig. 13 illustrates the condition of erection 40 hours later than that illustrated in Figs. 1 and 2, and 10 hours later than the condition shown in Fig. No. 12; during this period all of the final parts have been put in place, valve cut-offs checked up and the engine prepared for the paint shop. Fig. 14 illustrates the complete engine at a period 50 hours later than the conditions illustrated in Figs. 1 and 2, and 10 hours later than the condition illustrated in Fig. 13. During this period of time it has received the final finish in the paint shop and been delivered to the erecting shop, with the rods connected up and the tank, as per schedule "D," provided and

to the paint shop. The painting and complete finishing of cabs, except the final coat of varnish, is done in this department, and they are only delivered to the erecting shop when the engine is ready to receive them.

Testing.

To a very large extent the careful inspection and testing which this engine has received up to the point illustrated in Fig. 14 can be properly included as a test of the engine as far as its mechanical perfection is concerned, considered from a standpoint of workmanship. The test as to efficiency and general economy can only be made in actual service or by placing the engine on a specially equipped testing plant provided for the purpose. For very many reasons we consider the latter method the most satisfactory, permitting the test to be conducted under the direct supervision of the constructors of the engine and at the shops in which it has been

HAYES' TEN-WHEEL LOCOMOTIVE.

By M. N. Forney.

The illustration herewith is a copy of an old lithograph of what was known as the Hayes ten-wheeler, built for the Baltimore & Ohio Railroad, away back in the fifties. At that time that company had just opened its line west of Cumberland, and the trains had to surmount the continuous grade of 116 ft. to the mile for 17 miles, beginning at Piedmont. Passenger engines were taken up this grade with one of Winans' "camel" engines behind as a pusher. Mr. Samuel J. Hayes was then Master of Machinery, as the Superintendent of that department was called, and he conceived the idea of a passenger engine designed somewhat on the lines of the Winans camel engines. He adopted Winans' plan of boiler, with the sloping fire-box behind, and the cab on top, but he provided a leading truck in

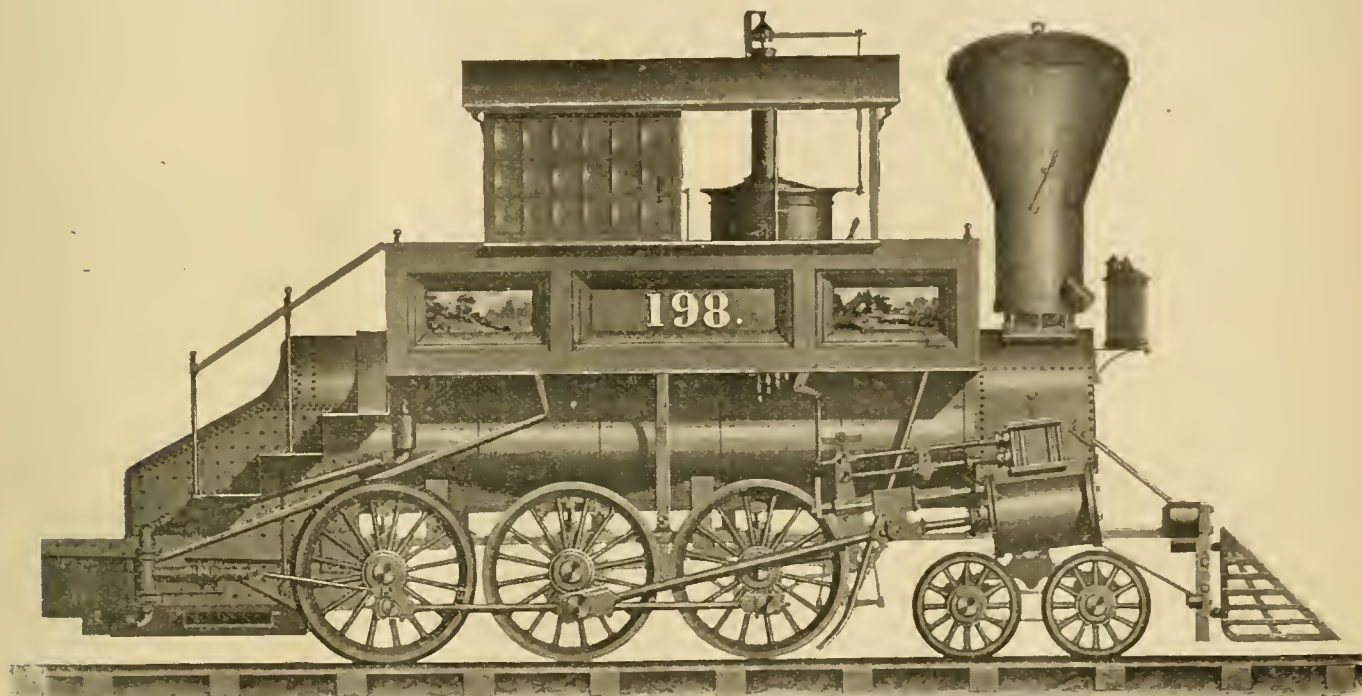

Hayes' Ten-Wheel Locomotive.

built, securing all of the incidental and valuable data in the form of records at that particular plant. The advantages of records of this kind in securing new business and meeting requirements of customers for locomotives will be obvious. Testing plants of this kind are not sufficiently common to warrant the advocacy of an arbitrary design, and while those that we know of have been very successful, we believe that future installations for this purpose will contain improvements and simplifications which these do not possess. It is, of course, understood that a plant of this kind can only determine the relative fuel economy, tractive force and general efficiency (as far as that character of information goes) of the machine as a hauling device, and that the imperfections of mechanical design, which would create an excessive cost for repairs, can only be determined by actual service, and we therefore think that for all practical purposes, including fuel consumption and hauling capacity, the test in actual service will sufficiently determine the relative economies of different types of engines.

The near approach to completeness in the use of interlocking and air-brake apparatus in Great Britain should be an example to us. Ninety-nine per cent. of the switch and signal levers on the railroads of the United Kingdom are interlocked and continuous brakes are in use on 95 per cent. of the locomotives and cars.

front which it was thought would make the engine curve better.

At that time Mr. Hayes had just been appointed to the position in charge of the machinery on the line, and his purpose was to produce an engine resembling the camel, but adapted to passenger service. Mr. David Rennie was Mr. Hayes' assistant, John Cochran was Mechanical Engineer and Mr. W. S. G. Baker, now President of the Baltimore Car Wheel Works, was his assistant. The lithograph was a copy of a drawing made by Mr. Baker, who writes that "The general designs were put in shape by Cochran, Mr. Hayes gave it careful attention as work progressed. There was much adverse criticism—Mr. Winans being among the critics. Zerah Colburn was a frequent visitor to the Mount Clare shops of the B. & O. road during those days, and he was a favorable critic. He was greatly interested in all matters pertaining to railroad progress, particularly in the mechanical appliances.

"The valve-gear received very serious attention and also the scheme of Cochran's of carrying the shaft which operated the withdrawal of the cut-off valve stem through the boiler. The cut-off rocker was loose on the shaft of the main-valve rocker and was in constant action when the engine moved.

"My general impression at the time was that Mr. Hayes conceived the general plan, which was worked up by Cochran with many comments by Mr. Rennie."

These engines were among the first, if not the first, ten

wheeled passenger engines used, but their use was not confined to passenger service, as they were found to be so efficient that they were also extensively adopted for freight service. After Mr. Hayes left the road a number of different forms of freight engines were built and bought by this company. During the war an increase of motive power was urgently needed, and had to be obtained as quickly as possible, and the question was which of the many kinds then in use would be the most servicable. Mr. Davis was then the Superintendent of Motive Power, and he and the older Mr. Garrett—then President—decided to have more of Hayes' ten-wheelers built, and the decision was carried out, with the modification that a link motion was substituted for the valve-gearing originally used.

For the following particulars and dimensions of these engines we are indebted to Mr. Baker, who in sending them, says: "I remember the very great interest I took in the success of the engine and how pleased and happy I was to take a ride in her from Piedmont to Altamont, up the 116-ft. grade, with three cars. She was considered a marvel."

He then adds, pathetically: "We are all old coveys now; I remember an old friend who was about 80, remarking to another about as young, 'that there were no more old people,' losing sight that they were both grown old."

Data and Dimensions.

The cylinders were 19 by 20 inches, with spring packing and brass rings on the pistons, the piston rods being of iron, 2¾ inches diameter. The steam ports were 1½ by 14 inches, the exhaust port 2½ by 14 inches, and the travel of the valve 4½ inches. The crossheads were made of brass, with gun metal gibs at the top and bottom, arranged with bolts and wedge shaped tops to take up wear. The guide rods were of wrought iron, and of diamond section. The main rods led to the center driving wheels and were 7 feet 7 inches from center to center. The tires for the main and leading drivers were 6½ inches wide and blind, the rear drivers having flanges. The centers of all the drivers were of cast iron, fitted with chilled faced cast iron tires, put on with a taper fit and held by lateral hook keys and nuts.

The driving wheels were 50 inches diameter and 52 inches from center to center. The truck wheels were 28 inches in diameter, with chilled faces placed 36 inches, center to center, and the center of the truck was 15 feet 8 inches from the center of the rear driving wheels. The main axle was 5½ inches in diameter, the others being 5 inches. The total weight of the engine was 60,000 pounds, about 48,000 pounds being on the drivers.

The truck bolster was of wrought iron, with its center forged on, the journals formed at the ends and fitted into housings resting upon and keyed to semi-elliptic springs, 36 inches long, the ends of which rested and slid within seats formed on top of the truck frames. The frames were of wrought iron, with the pedestal jaws forged on. The jaws were slotted to shape and fitted with cast iron shoes and wedges adjustable from below. The axle boxes were of gun metal and the springs were semi-elliptic, graduated. They were equalized upon the main boxes and were connected to the boxes by pins passing through the frames upon which the springs rested. The frames were rigidly secured to the smoke box, but were free at the firebox end and so arranged that the boiler was free to slide upon them and was held in place by sleeves passing around the frames and bolted to the firebox.

The boiler was horizontal and straight. It was 48 inches in diameter, with single riveted seams, and was made of 5-16-inch iron. The dome was 30 inches in diameter and 36 inches high, with a cast iron flange and top made with a ground joint. The safety valves were formed in the top and connected by a lever to a spring balance. The dome was placed 54 inches back of the front flue sheet. The firebox was of copper, with 5-16-inch sides and ¾-inch flue sheet. It was 42 by 58 inches in size and there were 160 2¼-inch flues of lap welded iron 14 feet 4 inches long.

The feed water was supplied by two single acting pumps attached to the sides of the firebox and operated by cranks attached to the crank pins of the rear driving wheels. The feed water entered the boiler by checks immediately in front of the back flue sheet, and was then conveyed by a pipe inside the boiler and discharged immediately back of the front flue sheets. Rocking grates were used, operated by a lever on the foot-

board, with a drop grate in front. The drawbar was attached to the ash pan as in the Winans camel engines.

The valve gear was of the hook type, with cut-off worked at half stroke, and operated by a separate eccentric and rocker. The valve stem of the cut-off was so arranged that it could be thrown out of gear, the valve remaining stationary when the cut-off was not used.

Steam was taken from the top of the dome through a slide valve throttle, operated by a crank connected to a screw with large pitch. The gage cocks were in the waist of the boiler below the footboard of the cab and operated by long stems and levers. The pilot in front of the engine was so arranged that it could be folded back when not on the road. This was done to permit of closing the doors of the engine house when the engine was in the stall. The smoke stack was arranged for soft coal fuel. It was formed with a center pipe 12 inches in diameter, over which a cast iron deflector was placed. This was to deflect sparks into a hopper formed by a second pipe, with a space between it and the central one. This space was provided with an outlet at the bottom to facilitate the removal of accumulated sparks. The top was provided with a bonnet hinged to the stack and covered with iron netting.

NEW SCHENECTADY FREIGHT MOGUL—NEW YORK CENTRAL & HUDSON RIVER RAILROAD.

A new 20 by 28-inch mogul locomotive, No. 786, has been built for the New York Central by the Schenectady Locomotive Works to specifications prepared by Mr. Wm. Buchanan, Superintendent of Motive Power, and its general appearance is shown in the photograph. This engine has pulled some very remarkable trains, the records of which we have received from the builders and reproduce in the table. It has hauled a train of 3,428 tons, composed of 81 loaded and one empty car, and on another trip 3,063 tons in 81 loaded and one empty. The freight was grain. The heaviest train was hauled on a consumption of only 4.5 pounds of coal per 100 tons per mile, which is remarkably low. In the opposite direction a train of one loaded car and 126 empties, weighing 1,834 tons, was moved with a consumption of but 7.7 pounds of coal per 100 tons per mile. The runs were made between West Albany and De Witt, a distance of 140 miles.

The weight of the engine on driving wheels is 123,000 pounds, and the cylinders are 20 by 28 inches. The heating surface is 2,110 square feet and the grate area 30 square feet. The boiler is not large in diameter, but it has an extended wagon top and large heating surface for its size. The firebox is 9 feet long and on top of the frames, the width being 40¾ inches. The crown sheet is supported by radial stays. Among the minor features are the large (9 by 12) driving journals, the extended piston-rods, which have made so good a name for themselves on this road, the very light pilot, and on the tender the suspension of the springs by links.

The information concerning the performance of this engine is incomplete without a statement of the grades, and we expect to show the profile of the road between West Albany and De Witt and some interesting indicator cards in a future issue. Until then we can only say that the grade line is undulating, and some of the curves are sharp. The new engine was designed to increase the average train loads on this division by 25 per cent. over those hauled by 19 x 26-inch mogul engines now used, and the heavy trains hauled in these tests are about 40 per cent. above the ordinary work done by the old engines. The new engine is able to haul 2,400 tons of paying load on this division, which is much better than the best work of the older design.

Records of six trial trips and general information pertaining to the engine are given as follows:

(It should be noted that the relatively high fuel consumption for the trip of September 28 was due largely to a 50-mile head wind.)

General Dimensions.

Gauge	4 feet 8½ inches
Fuel	Bituminous coal
Weight in working order.....	142,200 pounds
on drivers	123,000 pounds
Wheel base, driving.....	15 feet 2 inches
" " rigid.....	15 feet 2 inches
" " total.....	23 feet 3 inches

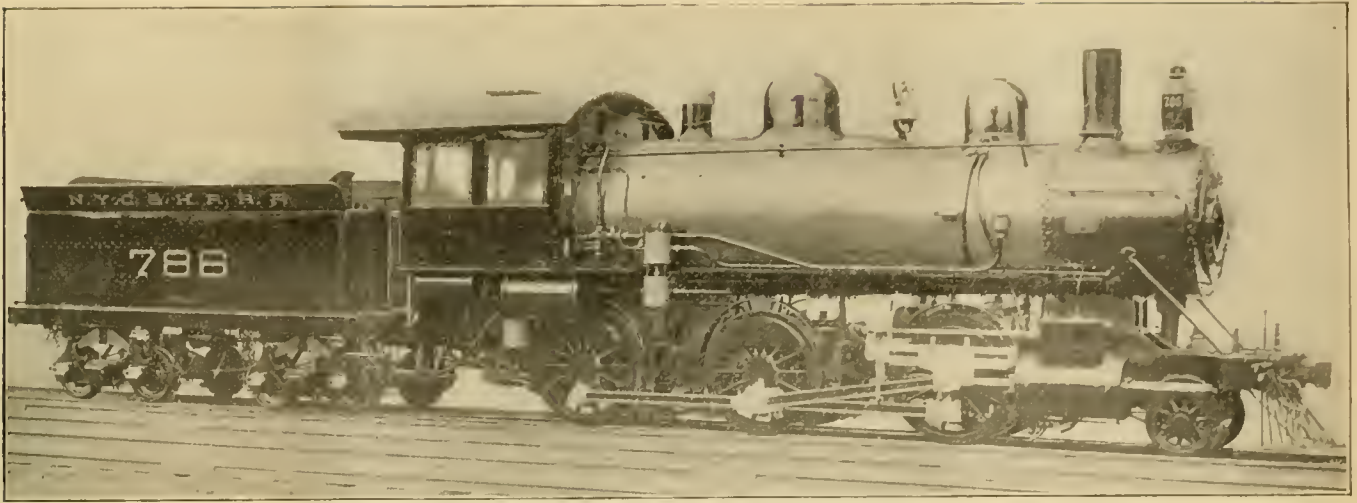

Schenectady Mogul Freight Locomotive—New York Central & Hudson River R. R.

Cylinders.		Firebox, depth.....	Front, 78 1/2 inches; back 66 1/2 inches
Diameter of cylinders.....	20 inches	" material.....	Carbon steel
Stroke of piston.....	23 inches	plates, thickness.....	Sides, 5-16 inch; back, 5-16 inch;
Horizontal thickness of piston.....	4 1/2 inches and 5 inches	" water space,	crowns, 1/2 inch; tube sheet, 1/2 inch
Diameter of piston rod.....	3 3/8 inches	" Front, 4 inches; sides, 3 1/2 inches; back, 3 1/2 inches	
Kind " " packing.....	Cast iron	" crown staying.....	Radial stays, 1 inch diameter
Size of steam ports.....	18 inches by 1 1/4 inches	stay bolts.....	1 inch diameter
" " exhaust.....	18 inches by 2 3/8 inches	Tubes, material.....	Charcoal iron
" " bridges.....	1 1/2 inch	" number of.....	310
Valves.		" diameter.....	2 inches
Kind of slide valves.....	American balanced	" length over tube sheets.....	12 feet 0 inches
Greatest travel of slide valves.....	5 1/2 inches	Heating surface, tubes.....	1,934.24 square feet
Outside lap.....	7/8 inch	" " water tubes.....	— square feet
Inside " " ".....	3 1/2 inches	" " firebox.....	176.6 square feet
Lead of valves in full gear.....	0 inch, 1-16 inch lap front and back	" total.....	2,110.84 square feet
Wheels, Etc.		Grate " style.....	30.3 square feet
Diameter of driving wheels outside of tire.....	57 inches	Ash pan.....	Sectional with dampers front and back
Material " " centers,	Main cast steel F. & B. steeled cast iron	Exhaust pipes.....	Double, high
Tire held by.....	Shrinkage	nozzles.....	3/4 inches, 3/4 inches and 3/4 inches diameter
Driving box material.....	Gun iron	Smoke stack, inside diameter.....	16 1/2 inches
Diameter and length of driving journals,	9 inches diameter by 12 inches	" top above rail.....	14 feet 8 inches
" " " " main crank pin journals,	(Main side, 6 3/4 inches diameter by 5 1/4 inches)	Boiler supplied by.....	Two Nathan & Co. Monitor No. 10 injectors
" " " " side rod	Front, 5 inches diameter by 3 3/4 inches	Tender.	
Engine truck, kind.....	Back, 5 inches diameter by 3 3/4 inches	Weight, empty.....	33,700 pounds
" " " journals.....	2 wheel, swing bolster	Wheels, number of.....	8
Diameter of engine truck wheels.....	6 1/2 inches diameter by 10 inches	" diameter.....	30 inches
Kind " " " Boiler.	Krupp steel tired cast iron spoke center	Journals, " and length.....	4 1/2 inches in diameter by 8 inches
Style.....	Extended wagon top	Wheel base.....	15 feet 10 1/4 inches
Outside diameter of first ring.....	62 inches	Tender frame.....	6 1/2 inches by 4 inches by 3/4 inch angle iron
Working pressure.....	180 pounds	trucks.....	4 wheel, wood bolster, side bearing, N. Y. C. style
Material of barrel and outside of firebox.....	Carbon steel	Water capacity.....	4,500 U. S. gallons
Thickness of plates in barrel and outside of firebox,	11-16 inch, 1/2 inch, 9-16 inch, 1/2 inch and 7-16 inch	Coal.....	10 tons
Firebox, length.....	10 1/2 inches	Total wheel base of engine and tender.....	50 feet 4 1/4 inches
" width.....	40 3/4 inches	Special Equipment.	
		American brake on all drivers, operated by air.	
		Westinghouse automatic air brake on tender and for train. 9/16-inch air pump.	
		2 3-inch muffled safety valves.	
		Gould coupler at front of engine and rear of tender.	
		1 16-inch round case headlight.	

Record of Six Trips Between West Albany, and De Witt.

Date.	September 28.	September 29.	September 30.	October 1.	October 3.	October 4.
Terminal points	W. A. to D. W.	D. W. to W. A.	W. A. to D. W.	D. W. to W. A.	W. A. to D. W.	D. W. to W. A.
Weather	Windy	Fair	Fair	Fair	Fair	Fair & Showery
Condition of rail	Good	Good	Good	Good	Good	Good & Slippery
Temperature atmosphere
Steam pressure.....	177	177.5	178.5	178.5	179	179.5
Elapsed time.....	10 hr. 12 min.	10 hr. 57 min.	10 hr. 24 min.	12 hr 5 min.	11 hr. 31 min.	12 hr. 31 min.
Detentions, number of.....	5	6	5	8	6	6
Running time.....	9 hr. 10 min.	9 hr. 6 min.	2 hr. 55 min.	10 hr. 3 min.	9 hr. 49 min.	6 hr. 53 min.
Average speed, miles per hour.....	15.17	15.27	15.62	13.83	14.2	14.04
Number cars in train.....	91 lt 1 load	21 lt. 71 load	112 lt. 1 load	11 lt. 81 load	126 lt. 1 load	11 lt. 85 load
Loaded weight train, tons.....	1,441	2,838	1639	3063	1834	3250
Number tons hauled 1 mile.....	200,299	394,482	227,821	425,757	251,926	451,750
Gallons water used, actual.....	13,781.6	14,138.2	15,617.8	16,133	16,839.8	17,804.8
Pounds water used, actual.....	114,846.6	118,295	125,156.3	136,911	140,331.7	148,273.3
Pounds water used in run.....	110,646	114,035	120,956.3	132,541	136,131.7	144,173.3
Pounds coal used, actual.....	17,080	16,890	18,280	18,300	20,200	21,120
Pounds coal used in run.....	16,480	15,280	17,680	17,700	19,600	20,520
Pounds coal per car per mile.....	1.29	1.52	1.13	1.55	1.11	1.71
Coal consumed per 100 tons, hauled 1 mile.....	8.2	2.87	7.7	4.1	7.7	4.5
Tons hauled 1 mile per pound coal.....	12.1	25.8	12.8	24	12.8	22
Tons hauled 1 mile per pound water.....	1.81	3.46	1.88	3.21	1.88	3.13
Average evaporation per pound coal, actual.....	6.72	7.00	6.84	7.48	6.95	7.00
Factor of evaporation.....	H—h	Equals 1.17 average taken for all				
Equivalent evaporation from and at 212 degrees per pound coal.....	965.7		8.00	8.75	8.13	8.19
Per cent moisture.....	7.86	8.19				
Equivalent evaporation per pound dry coal, average.....	1.5 in coal as weighed					
	8.28					

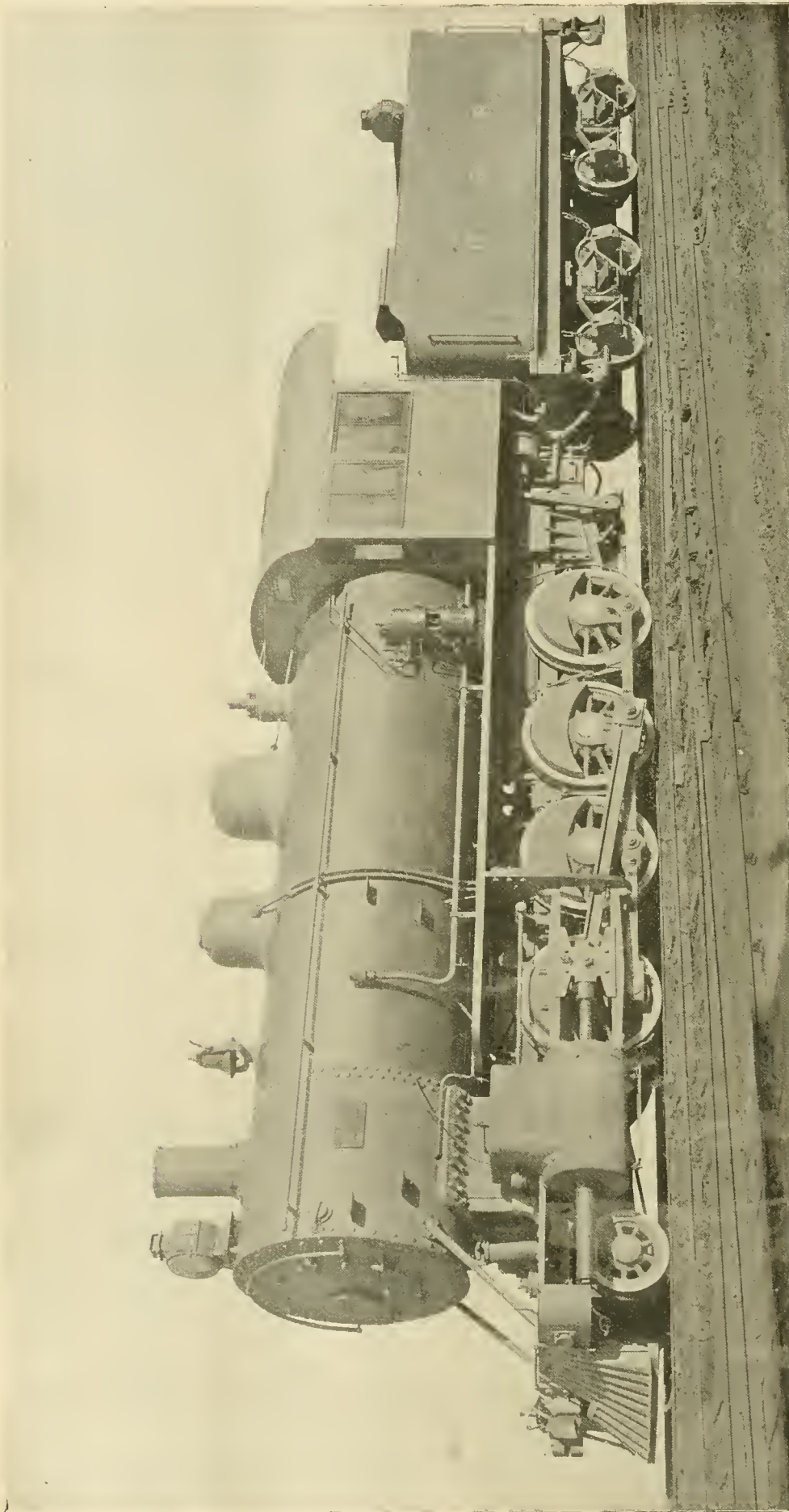

POWERFUL CONSOLIDATION LOCOMOTIVE FOR THE UNION RAILWAY,
THE LARGEST LOCOMOTIVE EVER BUILT.

THE PITTSBURGH LOCOMOTIVE WORKS, Builders.

CONSOLIDATION FREIGHT LOCOMOTIVES, UNION RAILROAD (CARNEGIE SYSTEM).

Through the courtesy of the Pittsburgh Locomotive Works we have received particulars of two enormous locomotives which they have just completed for the Union Railroad, a part of the Carnegie system. By referring to the tables published on page 1 of our January issue and page 296 of September of the current volume, it will be seen that these have the distinction of being the heaviest locomotives ever built. They weigh 208,000 pounds on drivers, and the total weight is 230,000 pounds. The cylinders are 23 by 32 inches, the boiler is straight with sloping back end and is 80 inches diameter at the front end, with other parts in proportion. The tubes are 2 1/4 inches diameter and 15 feet long, the firebox being 10 feet long and 3 feet 4 1/4 inches wide. It is 76 inches deep in front and 69 inches at the back, the material being Carnegie firebox steel. The front end is short, 68 inches, for such a big engine. The firebox is on top of the frames and the springs are over the driving boxes. The total heating surface is 3,322 square feet and the grate area 33.5 square feet. The driving wheels are 5.4 inches diameter and are of "steeled" cast iron, except the main wheels, which are of cast steel. The steam ports are 20 inches long. The engines are single expansion with extended piston rods.

The cylinders are of the half-saddle type, and the frame fastenings are very long. A steel plate 1 3/8 inches thick and of the same width as the bottom of the saddle, extends across the engine and is bolted to the lower frames, and to this plate as well as to the frames the cylinders are securely fastened. Heavy bolts passing through the top frame bars and the front and back of the saddle form additional transverse ties, and relieve the saddle casting from tensile strains. Longitudinal strains usually transmitted to cylinders through the frames are largely absorbed by the use of a casting extended from the bumper beam well up to the saddle, securely bolted to the top and bottom front frames. This casting also acts as a guide for the bolster pin of the truck. This method of relieving cylinders of longitudinal stress was introduced by the Pittsburgh Locomotive Works nearly two years ago, and has proven, in practical use on a large number of locomotives, to be of great value in reducing breakage of saddle castings. The photograph shows three rows of bolts fastening the saddle to the smoke box. The frames are 4 1/2 inches wide and have been cut from rolled steel slabs made by the Carnegie Steel Company and weigh 17,160 pounds per pair, finished.

The Union Railway, for which the locomotives have been constructed, is a part of the Carnegie system, connecting the Duquesne Furnaces, Homestead Steel Works and Edgar Thomson Steel Works, and extends, nominally, from Munhall to North Bessemer, Pa., a distance of about 12 miles. Some four miles of the line has a grade 70 feet per mile, while about 2,000 feet, from a point commencing at the yards near Edgar Thomson Steel Works, and passing up over the line of the Pennsylvania Railroad and ending at the foot of the 70-foot incline, there is a grade of 2.4 per cent. The locomotives are being operated daily upon this line, and steam freely, and, so far, appear not to be extravagant in the use of fuel and water. We hope soon to give some figures showing fuel and water consumption and tonnage hauled on the grades.

The following table gives the chief dimensions of the design in convenient form:

General Description.	
Type	Consolidation
Name of builder	Pittsburgh Locomotive Works
Name of operating road	Union Railroad
Gauge	4 feet 8 1/2 inches
Kind of fuel to be used	Bituminous coal
Weight on drivers	208,000 pounds
truck wheels	22,000 pounds
total	230,000 pounds
of tender loaded	104,000 pounds
total of engine and tender	334,000 pounds
Tractive power	53,292 pounds

Dimensions.	
Wheel base, total, of engine	24 feet 0 inches
" driving	15 feet 7 inches
" total (engine and tender)	54 feet 9 1/2 inches
Length over all, engine	39 feet 8 1/4 inches
" total (engine and tender)	65 feet 3 1/2 inches
Height, center of boiler above rails	9 feet 3 1/2 inches
of stack above rails	15 feet 6 inches
Heating surface, firebox	295 square feet
" tubes	3,116.5 square feet
" total	3,322 square feet
Grate area	33.5 square feet

Wheels and Journals.	
Drivers, number	8
" diameter	54 inches
" material of centers	Steeled cast iron
" main	Cast steel
Truck wheels, diameter	30 inches
Journals, driving axle, size	9 by 12 inches
truck	6 by 10 inches
Main crank pin, size	7 by 7 inches

Cylinders.	
Cylinders, diameter	23 inches
Piston, stroke	32 inches
rod, diameter	4 1/2 inches
" and valve stem packing	Metallic
Main rod, length center to center	9 feet 10 1/2 inches
Steam ports, length	20 inches
width	1 1/2 inches
Exhaust ports, length	20 inches
width	3 1/4 inches
Bridge, width	1 1/2 inches

Valves.	
Valves, greatest travel	6 inches
" outside lap	1 inch
" inside lap or clearance	0 inch
" lead in full gear	1-16 inch

Boiler.	
Boiler, type of	Straight with sloping back end
" working pressure	200 pounds
" material in barrel	Carnegie steel
" thickness of material in barrel	7/8 inch
" diameter of barrel at front sheet	80 inches
" " " throat	83 1/2 inches
" " " back head	74 1/2 inches
Thickness of tube sheet	5/8 inch
Crown sheet supported by stays	1 1/4 inch diameter
Dome, diameter	32 inches
Safety valves: two 3 inch open pops and one 3 inch muffler.	
Water supplied through two No. 11 injectors.	

Tubes.	
Tubes, number	355
" material	Knobbed charcoal iron
" outside diameter	2 1/4 inches
" length over sheets	15 feet 0 inches

Firebox.	
Firebox, length	10 feet 0 inches
" width	3 feet 4 1/4 inches
" depth, front	76 1/4 inches
" " back	69 7-16 inches
" material	Carnegie firebox steel
" thickness of sheets, crown	7-16 inch
" " " sides and back	3/8 inch
" " " tube	1/2 inch
" brick arch	Supported on studs
" water space, width	Front, 4 inches; sides, 4 inches; back, 4 inches

Grates, cast iron, rocking pattern.	
Grates, cast iron, rocking pattern.	

Smokebox.	
Smokebox, diameter	83 1/4 inches
" length from tube sheet to end	65 3/8 inches

Other Parts.	
Exhaust nozzle	Single
" diameter	5 1/4 inches
" distance of tip below center of boiler	5 5/8 inches
Netting, size of mesh	2 by 2 inches
Stack	Taper
" least diameter	17 inches
" greatest	18 inches
" height above smokebox	2 feet 9 inches
Track sander	Pneumatic
Power brake, Westinghouse, American.	

Tender.	
Type	With swivel trucks
Tank capacity, water	5,000 gallons
" coal	10 tons
Kind of material in tank	Carnegie steel
Thickness of tank sheets	1/4 inch and 5-16 inch
Type of under-frame	Steel channels
Type of truck	Diamond
Truck bolster	Rigid
Type of truck springs	Double elliptic
Diameter of truck wheels	33 inches
" and length of axle journals	5 by 9 inches
Distance between centers of journals	76 inches
Diameter of wheel fit on axle	6 3/4 inches
of center of axle	5 3/4 inches
Length of tender frame over bumpers	22 feet 11 1/4 inches
" " Tank	20 feet 6 inches
Width	9 feet 8 inches
Height of tank, not including collar	56 inches
" over collar	68 inches
Type of back drawhead	M. C. B. coupler

LOCOMOTIVE DESIGN—THE WORKING STRESS OF MATERIALS.

By Francis J. Cole.

Piston Rods.

The weakest part of a piston rod, and, consequently, where fractures usually occur, is at the crosshead connection. This can be accounted for by the reduced size of the taper part fitting in the crosshead, the cutting away of a portion for the key-slot, and the fact that a large percentage of crossheads are unbalanced and not symmetrical in weight, taking the longitudinal axis of the piston rod as a center. A bending stress in the rod at C, Fig. 1, is produced by the acceleration and retardation of the unbalanced weight at A, which is not entirely resisted by the guides, even when they are closely lined down with but little lost motion between them and the crosshead block. In cases where considerable lost motion exists, the entire bending stress has to be resisted by the piston rod at C.

The form of rod which is probably used on more locomotives than any other design is shown in Fig. 2. The body is cylindrical, without collars at either end, its diameter being from 1/8 to 1/2 an inch more than the reduced taper fits on the ends. The main reason for the popularity of this type and its very extensive use, is that glands, bushings and packings can be used without cutting in two parts, in order to slip over a col-

Laird crossheads (unbalanced), 3 1/4-inch iron rods reduced to 3 inches in crosshead fit, breakages sometimes occur. Net

$$\text{area of key-way, 4.69. Stress per square inch} = \frac{50,240}{4.69} = 10,712 \text{ pounds.}$$

As a general thing, it will be found that the stress taken at the weakest point—the key-way in the crosshead—will often run up to 12,000 or 13,000 pounds per square inch. Breakages are very common here, nearly always resulting in broken cylinder heads and flanges. Apart from the stress due to the steam pressure, the method of fastening the piston rod to the crosshead by means of a taper key driven to place has a tendency to overstrain the metal at the key-way and start incipient cracks, which, in time, are likely to extend and result in the breakage of the rod. In driving down the key the metal at A, Fig. 4, is compressed and that between the points B and C, is stretched. In extreme cases, where the key is driven with too great force, this may cause a crack to start in the key-way. A method of securing piston rods which has the advantage of not causing an initial stress by driving in the key is shown in Fig. 5. Here the compression caused by the key is taken up by the shoulder at the small end, and the metal in the key-way is not unduly stretched. It is an old idea, lately revived, and now undergoing a period

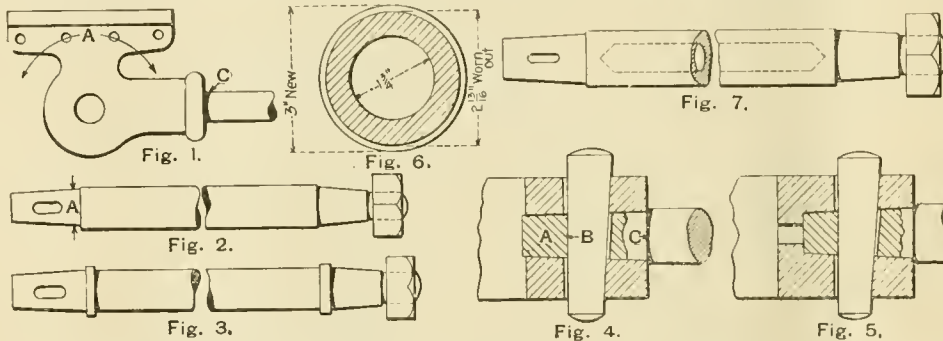

Diagrams of Locomotive Piston Rods.

lar, the supposition being that the rod is worn out, when turned down or trued up, to a diameter equaling the large diameter of the crosshead fit. A much better form is shown in Fig. 3, which, by the use of collars at the ends, the taper crosshead and piston fits, may be sufficiently large without unduly increasing the weight of the rod.

Piston rods are subjected to tensile, compression, and, where an unbalanced crosshead is used, to bending stresses. The ends, however, which are fitted into the crosshead and piston head, are in tension only, the compression being taken up by the collar and taper fit and absorbed before the weakest part which is cut away for the key-slot is reached. The conditions for alternating strains need not then be considered for the ends, but only for the main part or body of the rod. The working stress per square inch of net area through the key-way or at the root of the thread should be 9,000 pounds for steel and 8,000 pounds for iron rods. Assuming that first-class material is used in both cases, steel of 75,000 pounds and iron of 52,000 pounds, the factors of safety would be:

$$\text{Steel } \frac{75,000}{9,000} = 8.33. \quad \text{Iron } \frac{52,000}{8,000} = 6.50.$$

Among some memoranda of actual failures which came under the writer's personal observation are these notes: On passenger engines, with 18-inch diameter cylinders, steam pressure 160 pounds, balanced crossheads, 3-inch diameter iron rods reduced to 2 1/2 inches in the crosshead fit, breakages are frequent. Net area at key-way, 3.10. Stress per square inch = $\frac{40,640}{3.10} = 13,110$ pounds. On consolidation engines, with 20-inch diameter cylinders, 160 pounds steam pressure,

of resuscitation. The expense of boring the crosshead and fitting the rod is, however, slightly more than the ordinary form.

The table which is given below is based on a working stress of 9,000 pounds for steel and 8,000 pounds per square inch for iron rods. The key-ways are from 5-16 inch for 1 1/2 inch diameter of rod to 3/4 inch in width for 3 5/8 to 4 inches diameter of rod. In locomotives the stress which the rod has to resist should be taken as the area of the piston, multiplied by the maximum boiler pressure, without any deduction for the pressure of the exhaust steam on the other side of the piston. In single expansion engines this often does not amount to more than four or five pounds. In compound engines, of either the two or four-cylinder types, while the high pressure cylinder would show a considerable difference between the gross and the net actual unbalanced pressure on the piston rod when working as a compound, yet nearly all types, as at present constructed, are arranged to work as single expansion engines in starting, switching, and at other times when it is desirable to develop an unusual tractive power. The area of the piston, multiplied by the boiler pressure, should be used for single expansion and for the high-pressure cylinders of compound locomotives, and the maximum receiver pressure for compound locomotives. A suitable diameter of rod for either iron or steel can then be selected from the table. If the stress is kept within the limits named for the ends and the body of the rod is made the same size or larger than the dimension A, or the crosshead fit, it will be found that no other calculations as to the strength of the rod as a strut to resist buckling or bending are necessary, as the amount of metal in the body is more than sufficient for this stress.

The shearing stress for the steel key, or cotter, securing the rod to the crosshead, should be from 15,000 to 17,000 pounds calculated for single shear, or twice these figures for double shear. If steel of 75,000 to 85,000 pounds tensile strength which has sufficient elongation to insure its toughness, say, 18 to 20 per cent. in 4 inches, the higher figure can be safely used for widths of 1/2 inch or more. In case the keys are made of much softer steel—in the neighborhood of 65,000 pounds—the lower figure would be more suitable. It may be remarked, however, that the harder steel is better adapted for this purpose. Its use would indicate a better appreciation of this grade of material for work which must resist deformation in "keying up" and removing when the rod is disconnected, and for the bending stresses to which the key is subjected.

From a large number of different types of engines in actual service the shearing stress per square inch in single shear has been found to run from 9,000 to 22,617 pounds. The latter, however, is an exceptional case, 19,000 or 20,000 pounds being otherwise the outside figure, while the former is only found on very small engines. A noticeable tendency, however, to make the sizes entirely too large can be observed and out of all proportion on small engines, and to approach, without due regard to the stresses produced, the limit of safety in engines with cylinders of large diameters and high steam pressures. The bearing values in the key-way and on the key, figured from the sizes given in the table, range from about 16,000 pounds per square inch for the small sizes to 25,000 pounds for the largest. The latter figure is well within the limits of crushing and rapid wear for steels of the harder grade mentioned.

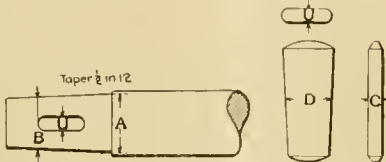

Least Dia. of Rod.	Dia. at "A."	Area at "B."	Key-way C.	Area of Key-way.	Net Area.	Working Stress.		Width of Key for Single Shear	
						Steel 9,000 lbs.	Iron 8,000 lbs.	of 15,000 lbs.	of 17,000 lbs.
1 1/8	1 1/8	1.35	1/8	0.41	0.94	8,460	7,520	1 1/8	1 1/8
1 1/4	1 1/4	1.48	1/8	0.43	1.05	9,450	8,400	1 1/8	1 1/8
1 3/8	1 3/8	1.76	3/8	0.56	1.20	10,800	9,600	1 1/8	1 1/8
1 1/2	1 3/4	2.07	3/8	0.61	1.46	13,140	11,680	1 1/8	1 1/8
2	1 3/4	2.40	1/2	0.76	1.61	14,760	13,120	1 1/4	1 1/4
2 1/8	2	2.76	1/2	0.82	1.91	17,460	15,520	1 1/4	1 1/4
2 1/4	2 1/8	3.11	1/2	1.00	2.14	19,230	17,120	1 1/4	1 1/4
2 3/8	2 1/4	3.54	1/2	1.07	2.47	22,230	19,700	1 1/4	1 1/4
2 1/2	2 3/8	3.97	1/2	1.27	2.70	24,300	21,600	1 1/2	1 1/2
2 5/8	2 3/4	4.43	1/2	1.33	3.10	27,900	24,800	1 1/2	1 1/2
3	2 5/8	4.90	1/2	1.56	3.34	30,960	28,720	1 1/2	1 1/2
3 1/8	2 3/4	5.41	3/4	1.64	3.77	33,930	30,160	1 1/2	1 1/2
3 1/4	3	5.94	3/4	1.72	4.22	37,980	33,760	1 1/2	1 1/2
3 1/2	3	6.49	3/4	1.80	4.69	42,210	37,520	1 1/2	1 1/2
3 3/4	3 1/8	7.06	3/4	1.88	5.18	46,620	41,140	1 1/2	1 1/2
3 5/8	3 1/4	7.67	3/4	2.15	5.62	50,580	44,960	1 1/2	1 1/2
3 3/4	3 1/2	8.29	3/4	2.23	6.06	54,540	48,480	1 1/2	1 1/2
3 7/8	3 3/4	8.91	3/4	2.53	6.33	51,720	50,640	1 1/2	1 1/2
3 7/8	3 3/4	9.28	3/4	2.03	6.70	59,850	53,600	1 1/2	1 1/2
3 7/8	3 3/4	9.96	3/4	2.72	7.24	66,160	57,920	1 1/2	1 1/2
4	3 7/8	10.68	3/4	2.81	7.87	70,830	62,960	1 1/2	1 1/2

In cases where it is desirable to reduce the weight of the reciprocating parts to the least possible amount, the body of the rod may be reduced to a diameter below that of the crosshead fit. The length between the piston and crosshead is about 35 to 36 inches for engines having 24-inch stroke. If it were practicable to reduce the diameter of the body from 3 inches to 2 1/2 inches in diameter, the saving in weight for each rod would be about 22 pounds. The principal thing to guard against in thus reducing the diameter is the liability to bend next the piston head, caused by water in the cylinder. This is more apt to occur in horizontal locomotive cylinders than in vertical engines. The water settling in the bottom of the cylinder and being crowded up in the ends of the piston produces more bending stress in the lower half of piston, on account of the water not immediately spreading out and equalizing the pressure when sharply struck by the piston moving at a high velocity. The liability to buckle can be investigated by considering the rod as a column with a square bearing—that is, with flat ends. For a solid round section the least radius of gyration

Diameter

$$= \frac{I}{r}$$
 For a hollow circular section the least radius of gyration = $\frac{D + d}{5.64}$. In "Materials of Construction," Prof. J. B.

Johnson shows that the ultimate strength of short columns is expressed by a parabolic curve, and is a function of the elastic limit of the material, and not of its ultimate strength.

- Let l = the length in inches.
- r = the least radius of gyration.
- P = the ultimate strength.
- E = the elastic limit of the material.

$$P = E - .62 \left(\frac{l}{r} \right)^2$$
 for short columns of medium steel, with flat ends.

The following table for steel of 44,000 pounds elastic limit has been computed by this formula, and it will be found to cover the ordinary range for locomotive piston rods:

l/r	Ultimate strength per square inch.	l/r	Ultimate strength per square inch.
35	43240	65	41350
40	43008	70	40962
45	42745	75	40612
50	42440	80	40322
55	42125	85	39520
60	41768	90	28978

A factor of safety of 5, based on the size of the rod when worn out, would give about the proper strength, and at the same time reduce the weight of the rod as low as would be consistent with the required stiffness. Take the case of a rod 3 inches diameter in body and 2 7/8 inches diameter at A, the crosshead fit. The working stress for this diameter, when made of steel, is 37,980 pounds. Assuming that the rod can be made 2 1/2 inches diameter, the least radius of gyration will be .625,

$$l/r = \frac{36}{.625} = 57$$
. The ultimate strength in table for 57 is about 37,980

42,000. Then $42,000 = 4.5 =$ an area equivalent to about 2 7-16

inches in diameter. Allowing 3-16 inch for wear, the rod would be 2 5/8 inches diameter when new and about 2 7-16 inches when worn out. The difference in weight would be about 16.8 pounds.

It must also be remembered that this part is subjected to alternating stresses, which, if viewed simply as a short bar in tension and compression, without reference to any reduction in strength due to buckling, can be investigated as follows: Assuming that medium steel will stand an infinite number of reversals of the load, equal to one-third of its ultimate strength, when applied and completely relieved, then steel of 75,000 pounds tensile strength would stand 25,000 pounds per square

inch when loaded in this manner: $\frac{25,000 \times 4.5}{37,980} = 2.9$, which is

about as low a factor as good practice would indicate. This factor, however, should be carefully noted as differing materially from the ordinary factor of five, based on the ultimate strength, as it is more properly a factor of the elastic limit, and should be so considered.

For the least weight, combined with the greatest strength, a hollow rod is the most suitable. Its resistance to bending is so much greater than the solid circular sections that the area could be reduced to the requirements necessary to resist the direct stresses due to the piston thrust and pull, uncomplicated by bending and buckling. Taking the figure at 37,980, as before, and a factor of safety of 2 1/2, the area required would be $37,980 \times 2.5$

$$\frac{25,000}{3.79} = 6.60$$

 2 13-16 dia. = 6.21 area
 2.40
 1 3/4 dia. = — area when worn out, or 3 inches diameter
 3.81

when new. This is shown in Fig. 6, and shows a saving of 24 pounds in weight of each rod over the solid section 3 inches diameter.

While the hollow rod presents the ideal form for the purpose, combining lightness and strength, yet the cost of manufacture is so out of proportion to the results obtained that their use, although often proposed, is at present very limited. What would seem to be one of the best methods of making these rods is to use heavy steel tubing, with solid ends, welded in, as shown in Fig. 7. This would give the full strength of the solid rods at the ends, where the metal is reduced by cutting away for the key-way and threads.

COMMUNICATIONS.

THE METRIC SYSTEM,
AS VIEWED BY AN AMERICAN IN RUSSIA.

Editor "American Engineer":

I have read with interest Mr. Grafstrom's article on the metric system, and Professor Mendenhall's supplement to it in the September number of your journal (pages 289 and 244), and consider them very timely. The general adoption of the metric system by the manufacturing establishments of the United States is no longer solely a question of academic speculation or purely scientific interest, but, in view of the large and increasing shipment of American machinery into countries where the system is in general use, it must be regarded as a live and important issue, which will, I feel confident, gradually force itself into such prominence that it must eventually be accepted. It has been my fortune during the last three years to have had a good deal to do with the management of large works where the metric system is used to a very great extent, but where the English units are also employed on some classes of work. For example, the diameter and pitch of all screw threads are figured in inches and fractions of inches, because the Whitworth system is in general use in the country, and our customers require us to conform to it. Having had practically no experience with the metric system until comparatively recently, many preceding years of intimate acquaintance with the two-foot rule probably made me somewhat biased against the millimeter and its multiples; but from almost the commencement of the time when I was called upon to work with the metric units my experience has been uniformly satisfactory. Calculations in the drawing-room are facilitated, strings of figures are more easily checked over, the rules of arithmetic are more readily complied with, and, most important of all, mistakes due to misreading of drawings in the shop are less frequent. The fact of there being two systems of measurement in the shop causes little or no trouble, and, certainly, if that is the case here, there would not be, to say the least, any more in an American establishment. It, therefore, seems to me that any opposition to the adoption, generally speaking, of metric standards in manufacturing concerns for everything, except possibly screw threads, is based either on prejudice, insufficient acquaintance with the working of the system, or from an exaggerated idea of the difficulties to be encountered and overcome while making the change from duodecimal to decimal standards.

The fallacy of the contention not infrequently met with, that because Great Britain has been the world's principal machine provider for so many years, while steadfastly rejecting the metric system, it is uncalled-for and unnecessary to suggest any change in its system of metrology, is so patent to an intelligent student of the international exchange of commodities that it seems almost incredible to find this discredited theory still seriously advanced, even by those who fail to appreciate the fact that times change, and unless we change with them, so much the worse for us. Great Britain's commanding position in trade was attained solely because she could furnish foreign nations with what they wanted in quantities, in quality, or at prices which practically allowed of no competition, and her system of metrology had absolutely no bearing on the matter. Within the last ten years, however, conditions have wonderfully changed. The United States, Germany, France and Belgium have all become commercial powers of magnitude; competition has been rendered very keen, and Great Britain has found that the methods of 25 years ago will not meet the requirements of to-day. In other words, she has begun to realize what an enormous difference there is between trade that came of itself and trade that has to be sought out. One reason for the relative falling off of British commerce has been the lack of adaptability of the manufacturers, the disinclination to change types or styles to suit special conditions. Cannot we learn a lesson from this?

American machinery has been shipped to Europe in large quantities during the past two or three years, and has, on the whole, made an excellent impression. But this market, like all others, must be cultivated carefully and assiduously, and one of the instruments of cultivation must be to fall in with the customers' wishes and requirements as fully as possible.

It would, of course, be foolish to assert that, because nearly

all American manufacturers use the inch and foot in their shops and in their catalogues and give the weight of shipments in pounds, they are, therefore, going to have extraordinary difficulty in doing business with what I may call the metric countries of Continental Europe, which comprise about all there are, as well as that vast territory just opening up, Asiatic Russia; yet, I feel it would be a distinct advantage if all weights, dimensions, etc., submitted were given in metric units, and from now on every little point will count. If, then, it is going to be advantageous to work in the metric system for a large foreign trade, why should not the same system be applied at home? There are no insurmountable obstacles in the way.

W. F. DIXON,

Chief Engineer Sormovo Company.

Locomotive Department, Nijni-Novgorod, Russia, Sept. 12th, 1898.

THE DUMMY COUPLING.

Editor "American Engineer":

There is undoubtedly truth in many of the things that you say on the subject of the dummy coupling on page 341 of your October issue. I am somewhat in doubt myself, considering both sides of the question, whether it is advisable to keep up the dummy coupling or not. I surely think that the present dummy coupling is worse than useless, as even when it is in good shape it does not entirely exclude the dust. It is well known that it is very difficult, and almost impossible, to make freight trainmen hang up the hose. Furthermore, with the largely increased equipment of air brake cars it will be proven desirable to operate all air brake cars that are in trains, and that being the case it is going to be the exception rather than the rule to have hose hanging down in such shape that dust can be collected. The present shape of the coupling is such that when it hangs down there is no lodging place for dirt inside of the coupling; if grains of sand go in they will by jar of the train drop out again. There have been several devices brought out for automatically closing the opening. I think all that I have seen, barring one exception, are likely to be a source of as much trouble as they are benefit.

The one kind that I refer to is really by name and by make a dummy coupling, and it couples up in the same manner as an ordinary coupling, making an absolutely tight joint without the use of a rubber gasket. The Michigan Central Railroad people have had considerable experience with a device of this kind on their locomotives, and speak of it in high terms. I understand that the Westinghouse Company have been considering putting a device of this kind on the market in the place of their present dummy coupling.

For some reason there seems to be a quite general sentiment to the effect that there is less use for the dummy coupling now than there was formerly, owing to the proportionately small number of air hose out of use when cars are in service. I question whether the condition of triple valves will be very much improved by applying an effective dummy coupling over that at the present time with the hose hanging down, and with the hose equipped with the latest style of Westinghouse couplings, which leaves no lodging place for dirt. On the whole, I think the action of the M. C. B. Association was a wise one.

A. M. WAITT,

General Master Car Builder.

L. S. & M. S. Ry., Cleveland, October 10, 1898.

Editor "American Engineer":

I have read your editorial on the dummy coupler on page 341 of your October issue and I have given considerable attention to this matter of the dummy coupler latterly, for the reason that I am well aware that men in charge of the car departments of our large roads have abandoned its use.

This has led me to examine the condition of the hose that are not hung up in the dummy coupling, and I do not find them as clean as those which are hung up. In my opinion it is merely a question of disciplining the men by obliging them in all cases to hang the hose in the dummy coupling. One of the strongest points raised by those abandoning the dummy coupling, as I understand, is that the men will not hang the hose up.

I believe that this is a very useful addition to the brake mechanism, and if the couplings are attached to a link, and

that to an angle iron, and fastened to the cars properly, the gasket will find its bearing against the face of the dummy, and not kink the hose, but will give it a curve. Hanging the hose up, as above, will exclude all foreign matter which will affect the air brake mechanism.

If, however, the dummy couplings are removed and nothing substituted to cover the opening in the hose, more or less foreign matter will adhere to the inner tube of the hose, most of this foreign matter consisting of grit and fine sand. When the hose are coupled together this foreign matter will follow the air in the pipes and some will adhere to the strainers in the drain cup and triple valves, and, if not cleaned often, they will clog up, thus giving a slow action of the brakes, also a slow recharge of the auxiliaries. Some of the grit will also pass through the meshes of the strainers and cut the triple valve piston packing rings more or less, also the cylinder packing leather. Some of this grit is likely to get into the engineer's brake valve, becoming the cause of frequent repairs.

The kinking of the hose will shorten its life considerably, but with the dummy coupling properly hung, and causing the hose to curve, it will not cause the hose to depreciate enough to offset the extra expense of maintaining the brake mechanism with the hose hung down and the dummy coupling removed.

J. T. CHAMBERLAIN,
Master Car Builder.

Boston & Maine R. R., Boston, October 10, 1898.

THE BREAKAGE OF PISTON RODS.

Editor "American Engineer."

On page 340 of the October number of the "American Engineer," there was an article about breakage of piston rods due to the rocking of the crosshead, with some suggestions as to making the piston rod flat at the crosshead end in order to allow it to bend slightly without fracture. I enclose a blue

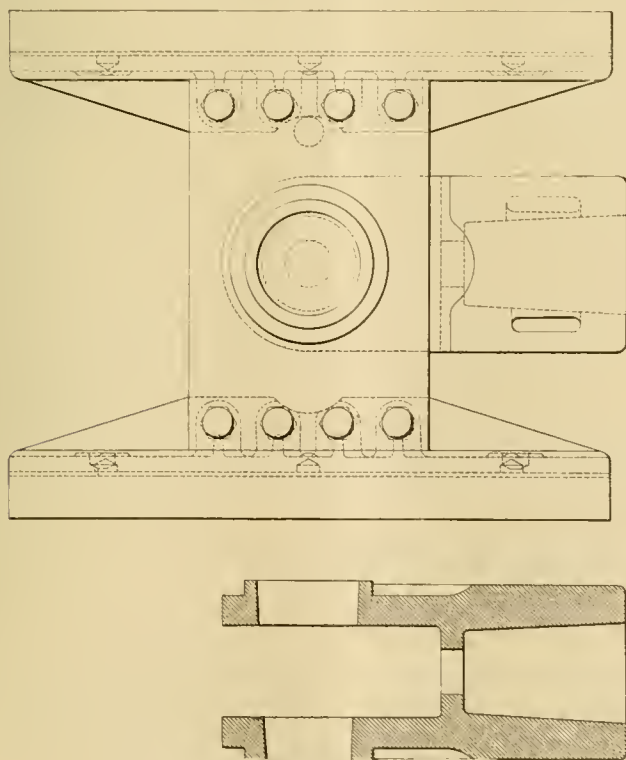

Articulated Crosshead—N. & W. Ry.

print showing what we consider to be a more desirable way of obviating the difficulty.

In this design the wrist pin connects the rod and crosshead center as usual, but the center itself is able to rotate within the sliding portion of the crosshead, so that any rocking of the latter would not be communicated to the rod, as a bending strain, the small amount of vertical motion being allowed for in the vibrating cup of the metallic packing. This is accomplished by forming bosses or trunnions on the forged steel

center, which trunnions fit into the side plates of the crosshead in such a manner as to allow of a rotation of the latter independently of the center. The plates are bolted to and connect the shoes to each other. We have had a pair of such crossheads running for 18 months, and the only difficulty has been a horizontal wear between the bosses and the side plates, which has had to be taken up by bushing. If the plates and trunnions were made thicker, this trouble would probably be obviated, and we believe that the device would absolutely prevent the breakage of piston rods from the causes assigned in your article above referred to.

G. R. HENDERSON, Mechanical Engineer,
Norfolk & Western Railway.

Roanoke, Va., October 10, 1898.

[The design of crosshead referred to by Mr. Henderson was illustrated in the "American Engineer," June, 1897, and owing to the interest in the subject, and Mr. Henderson's testimony after the experience of an additional year, we reproduce the engraving.—Editor.]

LOCOMOTIVE GRATES.

Editor "American Engineer":

I have read with great interest Mr. M. N. Forney's admirable article entitled "Locomotive Grates" in the current issue of the "American Engineer," and I hope that Mr. Forney will favor your readers with more articles of a similar character in the near future. The statement of the general problem confronting the locomotive designer in the matter of obtaining, within the available limits of weight and space, the most efficient boiler for a given locomotive, is excellent; as is also the explanation of the causes which render a relatively small grate area, large heating surface and large cubical contents of fire-box, conducive to the best evaporative efficiency of a locomotive boiler.

The design of grate which Mr. Forney illustrates apparently possesses an important advantage over the ordinary type from the standpoint of fuel economy, provided it develops no objectionable features in service, such as warping of the bars, becoming inoperative through the lodgment of cinders and clinkers, and provided, also, that enginemen can be induced to use it as intended, which, judging from their habitual neglect of the damper as a draft regulator, appears somewhat doubtful. However, this last is a matter of discipline, not a mechanical defect.

The following possible objection to the device occurs to me, but I mention it merely as a suggestion. If a locomotive equipped with the above type of grate is operated for the greater part of the time with a considerable portion of its grate area non-effective, and it is only occasionally necessary to utilize the entire grate area for active combustion (for instance, assume a road with severe adverse grades, separated by long stretches of comparatively level track), it seems probable that during the former period the fire above what is virtually a dead plate would die out, and that, consequently, a good deal of difficulty might be experienced by the fireman in again bringing to incandescence, particularly with poor qualities of coal.

Whether or not this objection is valid can, of course, only be satisfactorily determined by an experiment, although some opinions may be formed by those having had experience with dead plates, as ordinarily applied; but in any event the device appears well worthy of trial upon a locomotive, and I hope to see it tried.

EDWARD L. COSTER,
Assistant in Mechanical Engineering, Columbia University.
New York, Oct. 7, 1898.

The use of oil as a scale remover in steam boilers is treated in an article in a recent issue of "The Locomotive," the conclusions of which are summed up as follows: Mineral oil is often useful for the prevention or removal of scale, when it is properly applied; in the prevailing method of introduction, it gives good results in many cases; but when it has not proved as effective as desired, we recommend that the boiler be dried out and that the kerosene be sprayed upon the plates and tubes. It is important to avoid the use of open lights in or about a boiler that is being so treated; incandescent electric lights are the safest to use. Finally, kerosene is very serviceable for removing lubricating oils from plates and tubes.

PRESSED STEEL BODY AND TRUCK BOLSTERS,

PENNSYLVANIA STANDARD.

Designed at Altoona and Built by the Schoen Pressed Steel Co. for the Vandalia Line.

Through the courtesy of Mr. W. C. Arp, Superintendent of Motive Power of the Terre Haute & Indianapolis Railroad, the Vandalia Line, we have received the drawings of the new body and truck bolsters for 80,000 and 100,000 pounds capacity cars, from which a number have been built. The truck, with the exception of the axle, is for use under cars of both of the above-mentioned capacities. The design was made by the motive power department of the Pennsylvania Railroad at Altoona, and is the standard of that road, and the Vandalia Line, being a part of the Pennsylvania system, is using the same standards. The axle shown is the recent M. C. B. design

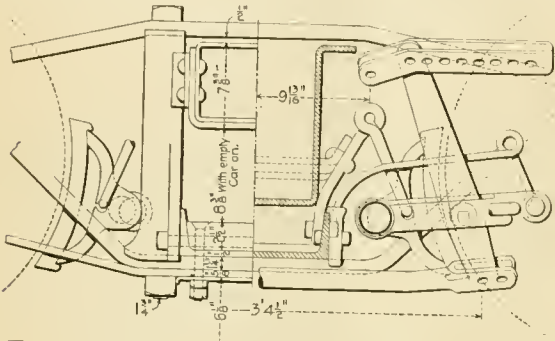

Partial End View of Truck.

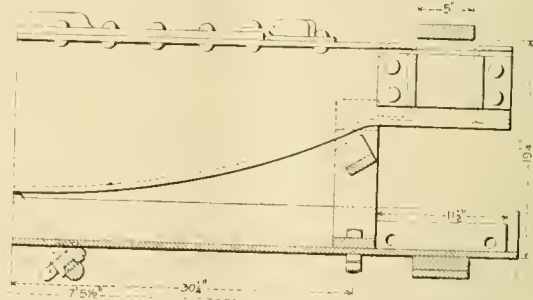
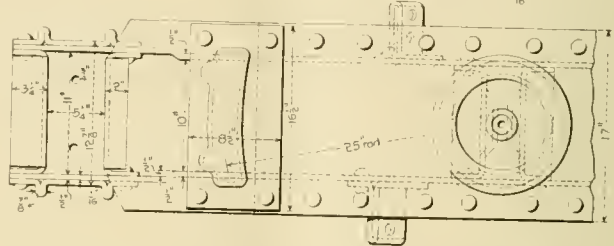
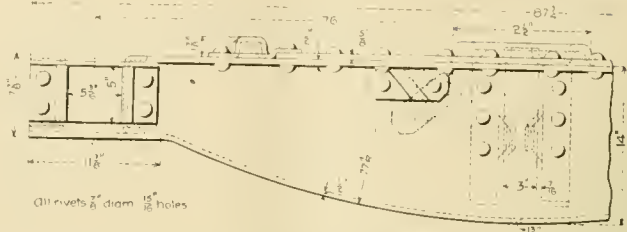

Truck Bolster.

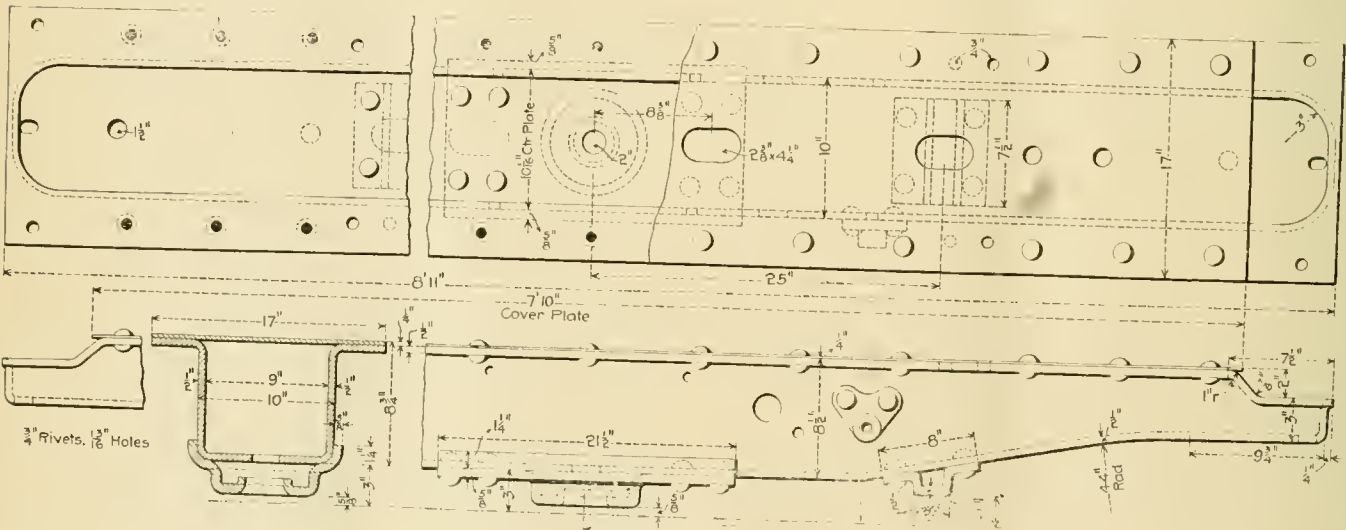

Body Bolster.

SCHOEN PRESSED STEEL BOLSTERS, PENNSYLVANIA STANDARD.

for 80,000-pound cars, and will not be used under cars of larger capacity. The bolsters are manufactured by the Schoen Pressed Steel Company, of Pittsburgh, Pa., and as shown in the engraving, the truck is of the diamond pattern. The weight of the truck bolster is 760 pounds, that of the body 606 pounds and that of the channel spring plank is 270 pounds. The method of constructing the bolsters is clearly indicated in the engravings, and it is only necessary to state that they are made in the form of covered troughs of 1/2-inch steel, pressed into shape in dies. The main portion of the bolster of each type is made in one piece with wide flanges which receive the cover plates. The brakes are inside hung, the manner of attachment being shown in the end view and section. The center plates, side bearings, center braces, and in fact all attachments are of pressed steel.

A LONG "BURLINGTON" TRAIN.

Oct. 1 was Chicago Day at the Trans-Mississippi Exposition in Omaha, and all of the railroads ran special trains, carrying delegates of the different Chicago organizations attending.

Among these was a special which left over the Burlington, and it was the longest train of Pullman cars that ever left Chicago on a regular run. It consisted of seventeen Pullman cars, one special private car, one baggage car and two engines.

The train shed at the Union Passenger Station, which is the longest one in Chicago, measures 1,100 feet, but the train measured exactly 1,337 feet, or more than a quarter of a mile long, and it started for Omaha at 2.30 p. m., scheduled to run at forty miles an hour. The weight of this caravan on wheels was estimated to be 22,290,000 pounds, or about 1,145 tons, and the two engines to pull the train over the 500 miles to Omaha burned 45 tons of coal and transformed into steam 53,000 gallons of water.

LOCOMOTIVE STAYBOLTS.

The difficulties with broken staybolts do not decrease, and there is more anxiety concerning them as the use of high pressures increases. We have endeavored to keep pace with this subject, and are forced to the conclusion that the only remedy for broken staybolts is to use stayless boilers, and this may yet be done. The pressing question is, how to reduce the present difficulties.

The form of the firebox, its depth and the lengths of the staybolts have very important influences, and some rather conclusive information on this subject has been gathered in a comparison of three different forms of fireboxes on three classes of engines on the Chicago & North Western Railway. The first,

used in a district where the water was excellent and much better than that for the other engines. The crown bar firebox did not make a bad record, and the big, shallow firebox made the best of all. There are at least two reasons to account for these results, and we think them important. The water space should be enlarged as much as possible, in order to increase the length of the staybolts and to increase their flexibility, and the depth of the firebox, from the beginning of the shorter bolts, should be as little as possible. Shortening the sides will decrease the expansion and contraction, which is believed to be one of the most destructive influences that staybolts have to encounter.

The distribution of the broken bolts in the different classes of engines is given in the table, and it will be noted that

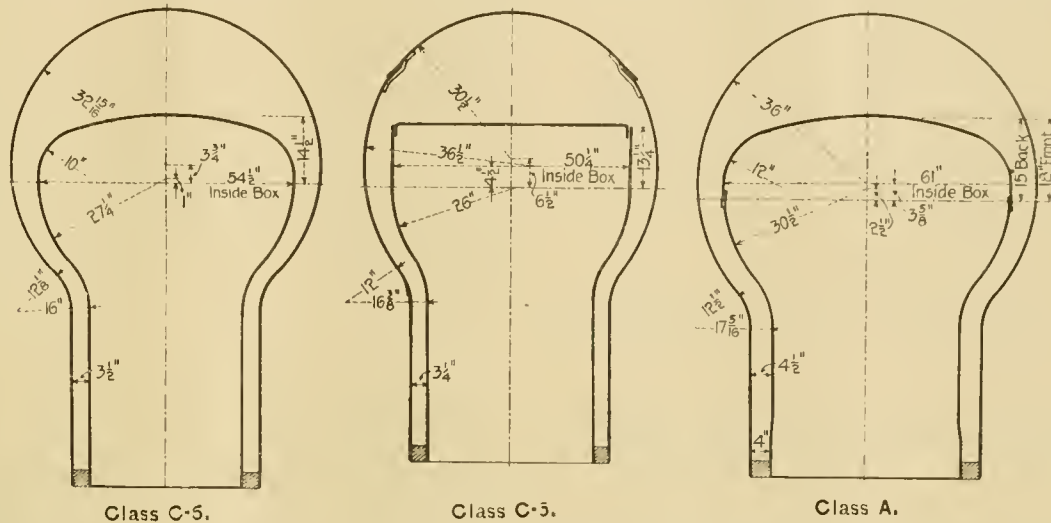

Effect of Firebox Construction on Staybolt Breakages.

class C 5, has a crown bar boiler, carrying 150 pounds of steam, and has deep and narrow water spaces. The second is class C 6, with radial stays and a deep firebox with narrow water spaces, carrying 180 pounds of steam. The third, class A, is the largest boiler used for this service, and until very recently the largest on the road. The class A locomotive was illustrated in our issue of January, 1896, page 4. It has a shallow firebox on top of the frames, and carries 190 pounds of steam. The three designs may be compared by means of the diagrams, which we reproduce to approximately the same scale, and in order to see the effects of the form, the relative depths of firebox and width of water leg should be noted. The class C 5 firebox is 72 inches long, the class C 6 is 74 inches long and the class A 96 inches long, inside. The length probably exerts some influence on the number of broken staybolts, but it does not seem likely that this would make much difference in these three boxes. The largest box would have more staybolts if it were of the same style and depth as the others, but in this case the number of staybolts was about the same in all classes.

A careful record of the broken staybolts for all engines is kept, and that for 18 class C 5, 10 class C 6 and 24 class A engines for six months shows the following:

Class C 5, 124 staybolts broken, or an average of 7 per engine; class C 6, 226 broken, or an average of 22.6 per engine, and class A, 32 broken, or an average of 1 1-3 per engine. It is interesting to note that the breakages on the class A engines were confined to 4 engines, 20 of the engines being entirely free from them for the entire six months. These fireboxes were not as long in service as the others, but the ages are not far different and are not believed to have made the comparison in the least unfair. The same may be said of the mileages. There were six out of 18 of the class C 5 engines free from breakages, and only three out of the 10 of class C 6.

The class C 6 firebox, which is small, with radial stays, made the poorest record, notwithstanding the fact that they were

the front sheets have the smallest numbers. The back sheets have nearly as many as the side sheets.

SUMMARIES.

Class.	Number of Engines.	Front.	Back.	Rght.	Left.	Total.
A	24	8	7	9	8	32
C5	18	9	34	45	36	124
C6	10	14	71	73	63	226

The fact that there were 20 of the first class with no breaks and 6 of the second and 3 of the third, is curious, and it would be valuable to know why these did not show some broken. There did not seem to be any evidence of different conditions in these cases, and we do not know the reason.

THE ANTI-SCALPING MOVEMENT.

An anti-scalping campaign was inaugurated at a meeting held in Chicago October 6, called by the directors of the National Association of Merchants and Travelers. By a unanimous resolution it was decided to appoint a central anti-scalping committee, with sub-committees in every large city to push the anti-scalping movement to a conclusion. Able addresses were given by Mr. Paul Morton of the Atchison, and Mr. George H. Daniels of the New York Central. Mr. Morton characterized scalping as "commercial savagery," and it could not be honestly conducted. He deplored the prevalence of legislation adverse to railroads, and showed that the interests of the roads were identical with those of the people. Scalping was one of the reforms most urgently needed.

Mr. George H. Daniels was introduced as the "father of the anti-scalping movement in the United States." He was glad to see the organization of business men take up the work, and the result of co-operation with the railroads in this movement was sure to benefit the whole traveling public. A number of men well known in the business world spoke in plain, strong terms in favor of squelching the scalpers, the result being the passage of the resolutions already referred to. The movement is gaining strength continually, and it is evident that the scalper must go.

(Established 1832)

AMERICAN ENGINEER

CAR BUILDER AND RAILROAD JOURNAL.

29TH YEAR.

67TH YEAR.

PUBLISHED MONTHLY

BY

R. M. VAN ARSDALE,

MORSE BUILDING.....NEW YORK

G. M. BASFORD, Editor.

NOVEMBER, 1898.

Subscription.—\$2.00 a year for the United States and Canada; \$2.50 a year to Foreign Countries embraced in the Universal Postal Union. Remit by Express Money Order, Draft or Post-Office Order. Subscriptions for this paper will be received and copies kept for sale by the Post Office News Co., 217 Dearborn Street, Chicago, Ill.

EDITORIAL ANNOUNCEMENTS.

Advertisements.—Nothing will be inserted in this journal for pay, EXCEPT IN THE ADVERTISING PAGES. The reading pages will contain only such matter as we consider of interest to our readers.

Special Notice.—As the AMERICAN ENGINEER, CAR BUILDER AND RAILROAD JOURNAL is printed and ready for mailing on the last day of the month, correspondence, advertisements, etc., intended for insertion must be received not later than the 20th day of each month.

Contributions.—Articles relating to railway rolling stock construction and management and kindred topics, by those who are practically acquainted with these subjects, are specially desired. Also early notices of official changes, and additions of new equipment for the road or the shop, by purchase or construction.

To Subscribers.—The AMERICAN ENGINEER, CAR BUILDER AND RAILROAD JOURNAL is mailed regularly to every subscriber each month. Any subscriber who fails to receive his paper ought at once to notify the postmaster at the office of delivery, and in case the paper is not then obtained this office should be notified, so that the missing paper may be supplied. When a subscriber changes his address he ought to notify this office at once, so that the paper may be sent to the proper destination.

The paper may be obtained and subscriptions for it sent to the following agencies: Chicago, Post Office News Co., 217 Dearborn Street. London, Eng., Sampson Low, Marston & Co., Limited St. Dunstan's House, Fetter Lane, E. C.

The dummy coupler for the air brake equipment of freight cars was discussed editorially last month, and elsewhere in this issue will be found some expressions of opinion on the subject from the men who know. One of our correspondents is very sanguine about the equipment of all cars with air brakes in the near future. There is good reason to believe that some of the trunk lines will soon have all of their cars so fitted, but there are comparatively few roads having the necessary facilities for storing and inspecting air brake cars, and these must be provided before the cars are all equipped. This will take time. Furthermore, the law does not require all the cars of freight trains to have air brakes, and there are good grounds for thinking that the interval between the present condition and total equipment will be a long one, although the brakes will in time be applied to all cars. During this interval there will be a great deal of mixing of cars with and without air brakes, and it is apparent that a good dummy coupler will be useful for some years. What Mr. Waitt says about the dirt dropping out of the new couplers is true, but it must be remembered that comparatively few freight cars have this coupler, and there will always be trouble with ice when air hose is allowed to hang.

In this issue will be found the views of Mr. W. F. Dixon, Chief Engineer of the Locomotive Department of the Sor-novo Works at Nijni-Norgorod, Russia, upon the metric system in its effect upon our foreign trade. These are formed in the light of European opinion of American machinery, and his opportunities for understanding the commercial importance of the subject are unusual. Mr. Dixon is an American and well known to many of our readers. He puts the matter on a commercial basis, and believes that our trade with metric countries will be benefited by the use of units that are most convenient to the customer. The export trade will not stop if English units are adhered to, but if it may be increased by so easy a method the business sagacity of our own manufacturers will not fail to accept the necessity for using metric units in business with metric countries. Mr. Dixon says of England: "She has begun to realize what an enormous difference there is between trade that came of itself and trade that has to be sought out. One reason for the relative falling off of British commerce has been the lack of adaptability of the manufacturers, the disinclination to change types or styles to suit special conditions. Cannot we learn a lesson from this?" The lesson is that it will pay to use metric units in catalogues, correspondence and designs for that trade. If this leads ultimately to the general adoption of the same units at home the situation will be simplified. Manufacturers will undoubtedly be glad to have the benefit of Mr. Dixon's experience.

MUST THE DISTANT SIGNAL GO?

Signal engineers and others have for a long time been discussing the usefulness and the dangerous character of the distant signal, yet no conclusion seems to be reached, and it will be interesting to see how long it will continue. One recommends doing away with these signals altogether, substituting a fixed sign-board to indicate the approach to an interlocking plant. He considers the function of the distant signal to consist in merely indicating the location of a danger point. He also believes that the distant signal as now generally used is a source of danger. Another would continue the signal, but would locate it 3,000 feet, or more, back from the home signal, and would require trains to pass it under control and maintain a relatively slow speed up to the home signal. This would delay all trains passing such signals, and in order to lessen this objection the distant signal would be used only where the view of the home signal is obscured.

These views seem to be unprogressive. They do not cover what may be called the primary principles of railroad signaling, namely, to promote high speeds with safety. Instead of delaying trains, signals should enable them to run faster and with safety. The distant signal itself is innocent enough. It is misused and needs to be safeguarded. This signal is required at all interlocking plants which are passed at high speeds. It should be located a sufficient distance from the home signal (1,200 feet is not enough for all cases); it should be kept in perfect adjustment and repair, and it should be connected to electric locks on the route governed by the signal. It is most important that the signal should be used and not abused, as is now too generally the case. If it is safeguarded in this way, it is hard to conceive how the distant signal can be anything but what it is intended to be—a help to trains and an element of safety.

STEEL FOR AXLES, CRANK PINS AND PISTON RODS.

Steel vs. iron for axles, crank pins and piston rods is an old story, the prejudice against steel having operated to delay its use by many as long as possible. At first steel was a very uncertain material, likely to fail, and generally unsatisfactory. Besides the matter of chemical composition, always an important one, those of manufacturing methods and fiber stress, both internal and external, have been studied, and now

steel parts which have been specially treated to correct the faults of constitution and manufacture may be had and used with confidence. The word prejudice is used advisedly, because there is even now a tendency to remember early and unfavorable experience, with a danger of overlooking the improvement in steel.

In European practice steel has almost entirely replaced iron for axles, and good wrought iron is becoming so difficult to obtain as to compel the use of steel whether desired or not. The cost of the special steels is said to be greater than that of iron, but this is not always true when the frequency of unavoidable defective forgings is considered. In visiting a shop on a road using iron pins almost exclusively, the number discarded was surprising, and the most expensive feature of the defective work is that often it does not develop until after having been some time in the lathe, when a seam will open, making it necessary to throw the piece away. This experience was also confirmed at one of the large locomotive works, where even after cleaning scrap in a tumbling barrel to remove the scale and dirt a large proportion of the forgings are not used on account of seams.

More attention is now given to the vital factors of fiber stress, elastic limit and ability to withstand repeated stresses, and these will decide the selection of material for the future. There are good reasons for improving the quality of axles and pins, not the least of which arises from the increasing weight of locomotives, and the axle problem, particularly, bids fair to be a difficult one. The most natural way to increase strength is to enlarge the diameter, but this may be carried too far on account of the increased surface velocity of the journals, and this is favorable to a stronger material, which may be either an alloy like nickel steel, or a product of a special process of manufacture like the "Coffin," which relieves the structure of initial stresses and raises the elastic limit without increasing the ultimate strength.

It is necessary to use great care in the preparation of specifications for steel, because of the intimate relations between chemical composition and physical properties, and it is possible that some purchasers have stood in their own light by specifying certain chemical composition which made it impossible to secure the desired physical properties. We know of one case of this kind that was used as an argument in favor of iron. Axles made by a special process were furnished in accordance with chemical specifications and barely met the physical tests. On machining them in the shop they were found to be hard and difficult to finish. In such a case it would be better to allow the manufacturers to use their own specifications on a guarantee of the quality of the product. Such a course would probably result in a more rapid introduction of steel, and in constant improvement in its quality.

The treatment of steel in the shop is important, and steel has been condemned because of mistakes in handling it in the machines. In one case a failure resulted from too high a speed in the lathe, which on examination was found to be over 20 feet per minute for the finishing cut, when the best practice with extra heavy lathes on the same material is 19 feet per minute for the roughing cut, and from 14 to 16 feet on the finishing cut. Often the best economy is found not in using the maximum speed, but in sacrificing speed in order to maintain a heavy cut, which heats the tool less. It seems in many cases to be good practice to work hard and slow. The desired end is to remove the maximum amount of metal in a given time, and this may be better done on a strong, stiff machine by a heavy cut and rapid feed and low-cutting speed than by light, fast cutting. The rate of cutting has had little to do with the adoption of steel, but what has been said serves to show that there may be good reasons for difficulties with steel for which the material itself was not in any way responsible.

The "mysterious" failures of steel are less frequent with more experience. The effect of light hammers is now well understood, and there is no longer any reason for accidents like that of the fracture of the shaft from the U. S. despatch

boat "Dolphin." It will be remembered that specimens cut from this shaft after failure showed 21.4 per cent. elongation at the outer edge, and only 2 per cent. near the center, the difference being due to the fact that the shaft was forged with too light a hammer, which was unable to affect the material to its center. There is no excuse for such failures now, nor is there any reason for similar ones with axles and pins. Good steel may now be had, but of course at a little higher first cost. Low first cost has undoubtedly been too much in mind in the purchase of these materials.

THE ADJUSTMENT OF PRICES OF CAR REPAIRS.

The adjustment of the prices which a railroad is allowed to charge a car owner for repairs to cars requiring them when away from home, in order to take into account the variations in the cost of material and labor in different parts of the country, is one of the most difficult problems now confronting the Master Car Builders' Association. The Western members brought the question up at the 1897 convention by showing that the cost of labor and material was more in the West than in the East, and that the prices provided for by the interchange rules were so low as to cause injustice to the Western roads, because they had to pay more to repair a car than they could charge for the work. The matter was reopened this year, and it is very important that it should be settled at the earliest possible moment. We do not presume to offer a solution, but we think we can state the case clearly from both sides, and thereby assist in an understanding of the situation, and this is the beginning of a solution.

The trouble is caused by the necessity for interchanging equipment, and the fact that the distribution of cars is such as to take a great many more of the Eastern cars West than there are Western cars coming East. If the distribution was even between the two sections, the roads would in effect be repairing a large number of other people's cars instead of an equal number of their own, but this is not the case. The number of Eastern cars used for through shipments from the East is much greater than the number of Western cars that go to the East.

For convenience the geographical division decided upon in the request for an adjustment is the 105th meridian. The Eastern representatives think that the use of their cars on the Western roads at a low rental of six mills per mile compensates the Western roads for their loss through the cost of repairs, and there is a great deal of opposition against establishing the precedent of a differential rate for any particular part of the country, because in a short time "they will all want it, and it will make lots of trouble." The East would like to keep its cars at home because of the necessarily rough usage they get on the Western lines, and they believe the extra wear and tear due to handling on mountain grades should not fall upon the owner.

It is said that Western cars are repaired in the East at lower rates than the owners would pay at home, this and the mileage of foreign cars being held to balance the matter of differences in prices. In regard to the mileage factor, Mr. Bush at the recent convention offered the following argument:

We have an average mileage rate for ordinary freight cars which covers the entire country. That rate is six mills per mile. It is very low. The average value of a car is \$400. The interest on that is \$24. The average mileage of freight cars on twenty-three of the principal roads of the United States is twenty-one miles per day. That gives a mileage of 7,560 miles a year. The return rate of six mills per mile is \$45.36 to the owner. Out of that he has to pay for the cost of maintenance, and included in that cost is the item of depreciation, and the renewal of cars worn out. At the very lowest four mills per mile will not cover the cost, and it will reach over five mills, as the cost of maintaining, including renewals, cars being destroyed, etc. Now assuming that it is over four mills for maintenance, that will mean \$30.24 per car per year. Admitting that the revenue received from the car is \$45, you have \$15

as the return on your investment. The railroads west of the 105th meridian are getting the benefit of that exceedingly low mileage rate. As Mr. McConnell showed by his figures, they are using more foreign cars than the mileage of their cars on Eastern roads, and his road and all the others in that section of the country are getting the benefit of that exceedingly low mileage rate, which I claim compensates them for any difference in the cost of making repairs, but even if it did not they would have to take their own equipment to do the business they are doing to-day with foreign cars. They would pay exactly the same amount of money and more to maintain their own equipment than they are paying to-day. In addition to that they could not get a fair return on their investment. The fact of the matter is, I believe the Western roads are ahead on account of being able to rent cars at a low mileage rate. I cannot bring myself to believe that it is any way just to make this differential rate.

The reply to this is that the mileage taken by Mr. Bush is too low to fairly represent the condition in the West. The Western roads claim to be getting the worst of both the mileage and the repair ends of the question. They say that twenty-one miles is too low a daily average, and this is supported by a record of an average of forty-five miles per day, taken for a month on the Union Pacific recently.

The East admits the greater cost of repairs to the West, but advances the argument that the entire cost of operation is greater, and it is balanced by higher freight charges. We have not heard this point answered as yet.

The Western men say: "We desire only fairness. We receive Eastern cars on our lines loaded with freight that is destined to distant points on our lines, and the cars must receive necessary repairs, which we make at a loss, because our rates for wages and materials are 31 per cent. more than the rules allow, whereas Eastern roads can get the actual cost of repairs from the car owners owing to their more favorable location with regard to wages and prices."

The Western men admit that they are hauling a great deal of freight in foreign cars, but they say that they do not want foreign cars at all, even at a low mileage rate, because they have their own cars lying idle while using those of the Eastern roads. One Western road handled 45 per cent. of its through business in foreign cars last year, and it is interesting to know that 29 per cent. of the mileage of these cars was non-productive, owing to the cars being empty. They do not want to use other people's cars even at six mills and would prefer to transfer all through freight to their own cars at the interchange points. This cannot be done because of expense and delay, and besides there is a great deal of freight that cannot be transferred owing to lack of facilities for handling it. The Eastern roads derive as much, if not more, benefit from the direct transfer of the car and its load, and the question of the Western men is: "Why, under these circumstances, should the Western roads be obliged to repair these cars at a loss?"

That this problem is intricate must be apparent to those who have followed us thus far. It is evident that the Master Car Builders' Association is not the final court for the case. If this is not already apparent, it will become so when the factor of the private car lines is considered. The element of reciprocity that constitutes the basis for the present claim of the Eastern men to fairness in the matter is lacking in the case of the private car lines, whose cars are repaired by both Eastern and Western roads at the same prices. This illustrates the inconsistency and incongruity of the situation better than anything else we know of. What we think of the merits of the case does not matter, and we do not consider ourselves competent to judge, but we believe that if any subject demands the consideration by General Managers this one does. The Master Car Builders cannot decide it alone without committing an error to correct another error, and this never has and never will work well. The appointment of a committee representing Eastern and Western, as well as private car lines, was a wise step, and the best course for the committee is to consider the question from the point of view of the Treasurer and Auditor, who have information necessary for a solution that is not to be had from the car departments.

NOTES.

A speed of 40.8 statute miles per hour is reported for the Chinese torpedo boat destroyer "Hai Lung," built by the Chichau Works at Elbing, Germany. The trials were made on a 19-knot course in the open sea and in moderately rough water. Several runs were made, the average speed being 35.2 knots, which is equivalent to 40.8 miles per hour.

H. M. S. "Terrible" has just completed extensive trials, during which the vessel traveled 6,000 miles and there were very few mishaps. In commenting upon the results "Engineering" says: "The trial certainly showed that no difficulty would be experienced in crossing the Atlantic at over 20 knots speed." While developing 25,115 I. H. P. the coal consumption was 2.11 pounds per horse power hour, including all auxiliaries.

The coal consumed in making scrap iron car axles at the Southern Pacific shops, as stated by Mr. D. Uren, before the Master Blacksmiths' Association, is 0.46 of a pound (bituminous) per pound of iron heated. The scrap is heated in four piles of 600 pounds each. These are roughed down the full length under the steam hammer, after which one half of the axle is heated and finished, and then the other half is treated likewise, three heats being required. The work is claimed to be improved enough by the heating to justify it.

Progress in railroad signaling in this country seems to tend in the direction of improvements in construction, in the substitution of iron and cement foundations in place of oak, and in the use of iron signal poles in place of wooden ones. These are very important improvements in the line of permanent structures to take the place of those which, under the most favorable conditions, can last only a few years. Electric locking, as applied to interlocking signals, is also making headway, and it may be said to meet with considerable favor. The effect of this is to increase the safety afforded by signals by surrounding them with a much-needed safeguard.

The largest schooner ever built is now being timbered at the shipyards of H. M. Bean at Camden, Maine. The vessel will have five masts and will be 318 feet long on deck, 44 feet 4 inches beam and 21 feet 6 inches deep. The frames are Virginia oak and the planking Georgia pine. Her masts will be 112 feet long, the foremast being 24 inches diameter and the others 28 inches. The spread of canvas will be 10,000 square yards. This large vessel will be manned by only 12 men. She will have electric lights, searchlight and steam hoisting appliances.

The development of long distance electric railways is now progressing in the direction of connecting the systems of cities that are not widely separated and extending them into inter-urban lines of considerable extent. The latest and longest line of this kind was described in our October issue, and as it may probably be considered as a type of long distance railroad transmission for further development, it is a specially interesting case. The transmission system finding most favor at present uses polyphase transmission current with converters and direct current motors. The Chicago & Milwaukee line is interesting also on account of the good ideas carried out in the power house, in the steam plant and in fact in the entire system for the purpose of guarding against a blockade from a breakdown.

Inclined planes with easy gradients have been substituted for stairways in the new railroad station recently opened in Providence, R. I. This new station is the outcome of efforts of 20 years to improve the passenger terminal facilities of that city, and the result is considered a decided success, the credit for which is due to Messrs. George B. Francis and Edwin P. Dawley, who have planned and executed the work for the New York, New Haven & Hartford Railroad. The plans included

raising the entire station yard above the surrounding street level by bridging and steel structural work, the elimination of a number of grade crossings, the filling in of a body of water, "The Cove," and the diversion of a tide channel. The structural work and bridges are an example of construction which, we believe, for permanence and solidity, is not surpassed anywhere in this country.

The air cylinders of locomotive air brake pumps are usually jacketed. This makes the steam and air ends uniform and improves their appearance, but the jacket tends to retain the heat, and if the jacket is tight the heat insulation is good enough to cause the packing of the air piston to burn out. The Boston & Maine, and probably some other roads, make a practice of removing the jacket and substitute a sheet of perforated plate smoke box netting. This is taken from scrapped netting, and it gives a good appearance without retaining the heat. It is a good plan, and there seems to be no reason why the air cylinders should not be finished in such a way as to look well without any covering. The steam cylinder and also the steam pipes should of course be insulated, but the air cylinder should be kept as cool as possible. This will benefit the packing and improve the efficiency of the pump.

The lessons drawn from the war by Admiral Sampson, in an interview printed in the Boston "Journal," are worthy of special attention on account of his exceptional opportunities for forming opinions, and also because of his experience as an ordnance officer. The Admiral would not only have warships fireproof, but he goes farther than that, and believes in discarding wood practically altogether. He sees no reason to condemn torpedo boats. They have not had a fair trial, and those that were used were not correctly designed. He prefers stronger boats and sees no advantages in speeds higher than 25 knots. Rapid fire guns 8 inch and smaller did practically all of the damage to the Spanish ships, and, while advocating rapidity of fire, he points out the fact that the armor of the Spanish ships was thin, and if it had been thicker larger calibers would be necessary. The 12-inch gun is, therefore, defended. Smokeless powder is strongly advocated. It permits of seeing what is going on and also offers the advantage of 400 feet per second in velocity over ordinary powder. A total of over 12,000 men were engaged in the service of the warships, and there were only 20 casualties among them. This is unprecedented, and the Admiral believes it to be due to the fact that our navy is on a perpetual war basis, including the supplies departments, and the effectiveness was due to the target practice.

Strengthening the Master Car Builders' coupler is the subject of an article in the October issue of the "Railway Master Mechanic." The objections which have arisen to the coupler since its adoption are not to condemn the coupler to disuse, because "with all its faults, we have it still," and the important question is, how to improve it and avoid some of the objectionable features, the effects of which are, perhaps, greatly exaggerated. Attention is directed to the fact that the close coupling feature of this type has contributed in an important way to the introduction of the continuous brake, and it was shown in the Burlington brake tests that the brakes could not be applied on 50-car trains without this feature. The article describes the recent experiment on the Chicago, Burlington & Quincy in strengthening the coupler knuckle by reducing the width of the link slot from the customary practice of $2\frac{1}{4}$ to $1\frac{1}{2}$ inches. The slot was originally made wide enough to admit pilot bars, but as these have practically gone out of use, the width is reduced in order to strengthen the lower lug of the knuckle, the upper lug being unchanged. In commenting upon this experiment, the suggestion is made that perhaps the gain in strength may be offset somewhat by possible binding of links that may be coupled to these knuckles, particularly in case of using links of large diameter iron.

Furthermore, records show that only four per cent. of the breakages of knuckle lugs occur in the lower lug. The opinion is expressed that a width of $2\frac{1}{4}$ is unnecessary, and the attempt to improve the knuckles is commended as "an earnest effort in which every master mechanic should be working—that is, the strengthening of the M. C. B. coupler."

ROLLING STOCK EQUIPMENT IN THE UNITED STATES.

From summaries which will appear in the Tenth Statistical Report of the Interstate Commerce Commission, prepared by its statistician, being the complete report for the year ending June 30, 1897, the following advance figures are obtained:

The total number of locomotives in service on June 30, 1897, was 35,986, the increase in number as compared with the preceding year being 36. Of the total number of locomotives reported, 10,017 were classed as passenger locomotives; 20,398 as freight locomotives, and 5,102 as switching locomotives. The number of locomotives not classified was 469. The total number of cars of all classes reported in service on the date named was 1,297,480. The corresponding number for the previous year was 169 greater. Of the total cars reported 33,026, or 623 more than for 1896, were assigned to the passenger service; 1,221,730 were assigned to freight service, indicating a decrease of 157 during the year; and 42,124 were assigned to the special service of the railway companies. As has been stated in former years, the Division of Statistics has no record of the number of cars owned by private companies and individuals that are used by railways in transportation service.

From summaries which indicate the density of equipment and its efficiency in the transportation of passengers and freight, it is observed that during the year ending June 30, 1897, the railways in the United States used 20 locomotives and 708 cars per 100 miles of line. Taking the United States as a whole, it appears that 48,861 passengers were carried and 1,223,614 passenger-miles accomplished per passenger locomotive, and correspondingly there were 36,362 tons carried and 4,664,135 ton-miles accomplished per freight locomotive. All of these items show a decrease as compared with those of the preceding year. The number of passenger cars per 1,000,000 passengers carried during the year under consideration was 69, and the number of freight cars per 1,000,000 tons of freight carried was 1,647. It should be understood, however, that this average does not include such cars, mainly in the freight service, as are owned by private parties, for the use of which the railways paid during the year approximately \$11,000,000. Including in the term equipment both locomotives and cars, it is found that the total equipment of railways on June 30, 1897, was 1,333,466. These figures are 133 less than on June 30, 1896. Of this total number 525,286 were fitted with train brakes, the increase being 76,432; and 678,725 were fitted with automatic couplers, the increase in this case being 133,142. These increases are somewhat smaller than the corresponding increases for 1896. It should be noted, however, that the number representing the increase in equipment in that year was over 27,000. Further details as to equipment on June 30, 1897, show that the number of passenger locomotives fitted with train brakes was 9,899, or 83 more than the preceding year. The number of freight locomotives so fitted was 18,796, or 875 more than the preceding year. The number of switching locomotives fitted with train brakes was 3,666. The number of passenger locomotives fitted with automatic couplers was 4,687, the increase with respect to 1896 being 184. The number of freight locomotives fitted with automatic couplers was 4,302, the increase being 819. The number of switching locomotives fitted with such couplers was 741, or 147 more than for 1896. The number of passenger cars fitted with train brakes on June 30, 1897, was 33,078, and the number fitted with automatic couplers was 32,661, the increase in the one case being 665 and in the other 815. The number of cars in freight service fitted with train brakes was 453,688, or 74,630 more than on June 30 of the previous year. The number fitted with automatic couplers was 629,399, indicating an increase of 129,166. Of the total cars in service 492,559 on June 30, 1897, were fitted with train brakes, and 668,937 were fitted with automatic couplers, the increase for the year in the former case being 75,237; in the latter, 131,989.

METALLIC ROD PACKING AND FLEXIBLE METALLIC STEAM HEAT CONDUIT—BOSTON & MAINE R. R.

Mr. M. P. McLaughlin, of the Boston & Maine R. R., has perfected and patented two devices which have been adopted for general use on that road, and have also been applied to a number of engines on other roads. They are both highly spoken of by Mr. Henry Bartlett, Superintendent of Motive Power.

Flexible Steam Heat Conduit.

This arrangement is for the steam heat connection between locomotives and tenders and between cars. The illustration

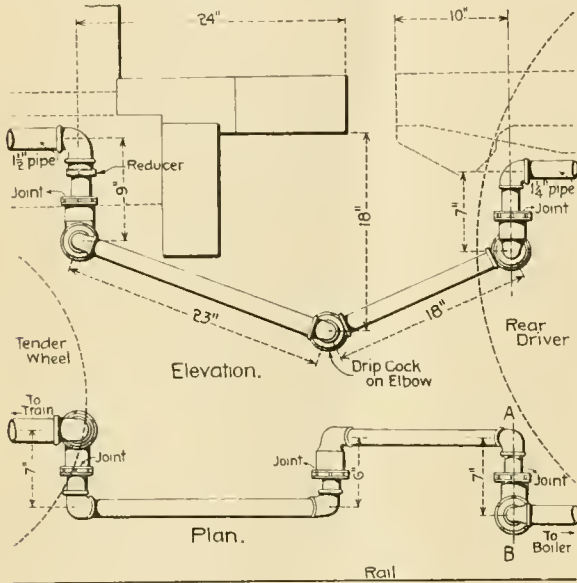

Plan and Elevation of Steam Heat Conduit.

shows it connecting a locomotive and tender. The joints in the pipe are made by swiveling elbows. A nipple, with an enlarged end, is inserted in the bore of the elbow, and is free to turn therein, but is held in place by a cup nut, against which the shoulder, or enlargement of the elbow, bears. A ring of vulcanized rubber is inserted between these surfaces to make the steam-tight joint and to provide for taking up wear. While adapted to and used for a large number of purposes requiring flexible connections, the most severe test has

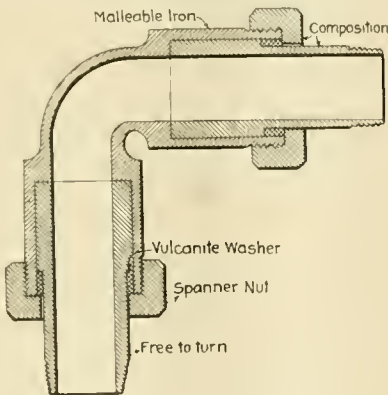

Section of Swivel Joint.

been made in connecting locomotives and tenders for steam heating. In this exacting service the arrangement has given excellent satisfaction for a period of a year and a half. It wears well and does not leak. The construction is shown in the engravings.

Metallic Rod Packing.

The metallic packing is for piston rods and valve stems. It consists of two concentric rings of "anti-friction" metal, each

of which is split longitudinally to put it in place, and the ends are formed into conical bearing surfaces. The inner ring is divided circumferentially into two abutting portions, and the outer one is encircled by a flat steel spring to keep the packing together and to assist in making it tight. When applied to air pump piston rods the packing is inserted in the regular stuffing box with a gland of such length that when brought to a bearing on the packing the flange of the gland is not quite in contact with the end of the stuffing box. When put into service the nut is gradually turned up until the gland bears on

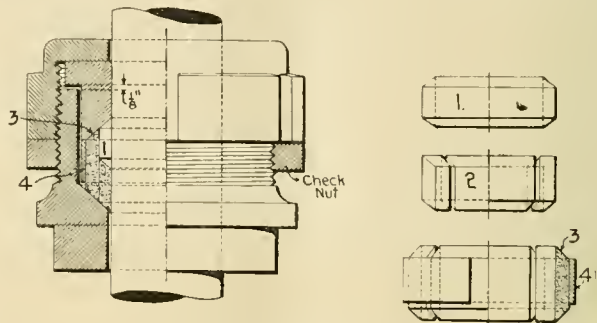

Metallic Rod Packing.

the end of the stuffing box. The packing will then run for a long time without attention. It is used on a large number of air pumps, and the usual life is from 18 months to two years, or between the shoppings of the engine for general repairs. Its use has also resulted in a marked decrease in the wear of the piston rods. It is equally successful on valve stems and locomotive piston rods.

CHILLED WHEELS FOR 100,000 LBS. CAPACITY CARS.

In view of the interest taken by railroad officials at the present time in the question of large capacity cars, a pamphlet recently issued by the New York Car Wheel Works, of Buffalo, showing tests on wheels suitable for 100,000 pounds capacity cars, is most timely.

It goes without saying that the heavier loads will produce internal strains in wheels when brakes are applied many times greater than ever before experienced, and it is a question whether the standard 550 pounds or the 600 pounds wheel now used under 60,000 pounds capacity cars will stand these strains.

It would seem to be a simple matter to increase the weight of the wheel proportionately, but this would necessitate making the plates of the wheel that are now 3/4 inch thick, from 1 to 1 1/2 inches thick, and this would make uniform cooling difficult and would induce shrinkage strains.

The New York Car Wheel Works have approached the problem from the standpoint of an increase in strength in the iron used and the pamphlet describes tests made on wheels weighing 650 pounds intended for use under 100,000 pound capacity cars, to demonstrate that the necessary strength had been obtained.

The series of tests made rather naturally divide themselves into three groups:

First, the drop tests, Nos. 1, 2, 3 and 6; second, the bursting tests, Nos. 4 and 7, and, third, the thermal test, No. 8.

The first group shows not only the transverse strength of the iron in the wheel, but its ability to successfully stand the severe shocks and blows of service.

A radical departure was made from the ordinary Master Car Builders' test used exclusively in this country by subjecting the wheels to the test required under the specifications of the leading European railroads for steel wheels, and one is at once struck with the far greater size of the weights employed and the height from which they are dropped. It is

interesting and instructive to compare the force of the blow struck in foot pounds in each case. In the Master Car Builders' test this is 1,650 foot pounds, while in the Austro-Hungarian it is 9,500 foot pounds, and in the French State Railway 30,800 foot pounds, or over 18 times as severe as the test ordinarily employed in this country. That chilled wheels can be made to withstand such severe tests shows a very decided step in advance in wheel manufacture, and the pamphlet shows that the wheels not only stood the number of blows required under the specifications, but in every case more than double that number.

The second, or bursting, group demonstrates the ability of the wheel to stand internal strains, and it will be noted that a steel wedge with a taper of 1 in 20 was driven into the segmental bushing fitting the bore of the wheel by 13 blows of a 475-pound weight, without cracking the wheel.

In the test with the tapering steel axle, where the pressures were recorded, 100 tons was reached without causing the slightest crack in the hub or plates.

The thermal test was intended to reproduce the heating

It is considered that the expansion of the wheel during this test caused an enlargement of its diameter of $\frac{3}{4}$ inch, all of which had to be taken up by the metal in the rim and a portion of the single plate.

In actual service the heating due to brake application is so gradual that time is given for its penetration into the double



Special 33-inch, 650-lb. Pittsburg, Bessemer & Lake Erie Railroad Wheel.

In position for first blow under German State Railway specifications. Hub bored to receive conical steel sections with interior tapering steel wedge, machined and fitted.

action due to the application of the brakes and to demonstrate that the wheel would successfully stand the severe strains thus induced. In reality the thermal test, as made in the tests described, was many times more severe than anything that would ever be found in service, owing to the fact that the molten iron ring is at a temperature approximating 2,600 degrees, while the wheel is at the temperature of the atmosphere. In the two minutes in which the band is in contact with the tread the temperature of this portion is raised to about that of the ring, while the temperature of the hub and plates was practically unchanged.

The enormous strain induced will be better appreciated when



33-inch, 650-lb. Special Wheel After Thermal Test.

plates, frequently as far as the hub, and thus the strain is distributed over a much larger surface.

In a future issue we shall give a result of the tests made on the wheels placed under the 100,000 pounds capacity steel hopper cars built for the Pittsburg, Bessemer & Lake Erie Railroad, the wheels being made by the New York Car Wheel Works and the tests by the Carnegie inspector.

THE AMERICAN RAILWAY ASSOCIATION AND THE METRIC SYSTEM.

The committee of the American Railway Association on the metric system, at the recent meeting in New York, made a report, of which the following is an abstract:

"The events of grave and national importance that have transpired during the past six months, which may result in changes in the foreign relations of the country, have been used as an argument by those who favor the adoption here of the metric system. It is claimed that unless our manufacturers make their goods according to the metric weights and measures they will be handicapped in their competition for foreign markets. Whether such arguments will be forcible enough to create a general demand for the change to the metric system is a question that your committee does not feel called upon to discuss. If, however, such a demand should arise from any cause, it would be important that our railway officials should know what it would be necessary for them to do in making the change.

"Your committee has, therefore, under consideration a plan by which it hopes to be able to report upon the methods which it would be necessary to employ in the introduction of the metric system in each railway department. This would include an examination into the difficulties to be overcome and the expense involved in changing from one system to another. If your committee succeeds in obtaining the desired information the association will have data before it from which the whole question can be more intelligently discussed in its relation to railway operations.

"Some of our manufacturers have recently inserted in their publications special tables of metric dimensions. Your committee will endeavor to ascertain to what extent this is being done, and report upon the subject at a future meeting."

PNEUMATIC RIVETING ON A LARGE SCALE AT ONE-FIFTH THE COST OF HAND WORK.

The use of pneumatic riveters in shipyard, bridge shop and other equally important engineering work is one of the greatest of recent improvements in these lines. The success is due to the rapidity of operation and convenience of the tools and careful examination of the quality of the work is convincing as regards its satisfactory quality. We have repeatedly directed attention to the value of pneumatic tools and to the economies which their use permits. A remarkably good demonstration of these features is at hand in the record of the construction of a long hydraulic pipe line in San Francisco, Cal., by the Risdon Iron & Locomotive Works of that city. Our engraving illustrates the ingenious riveters used in this work

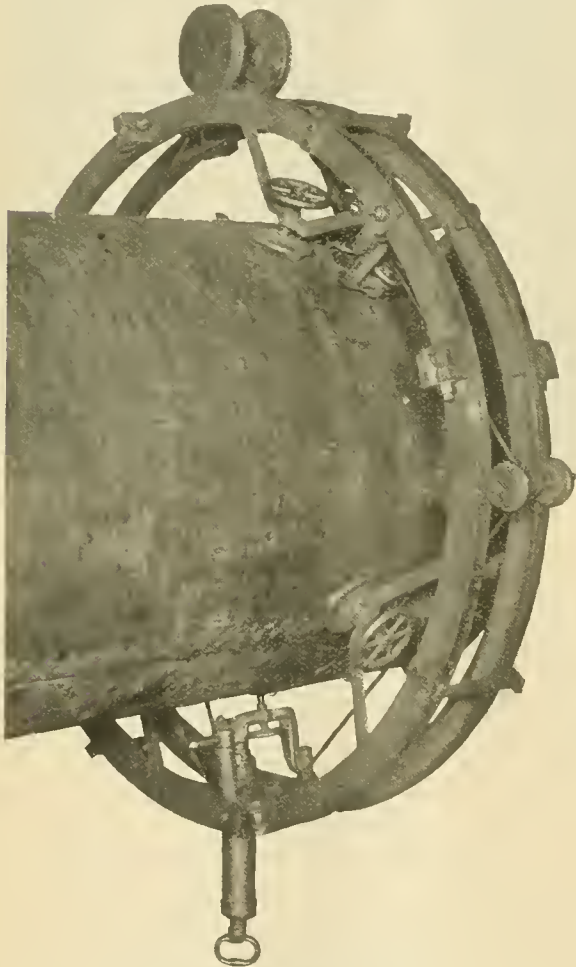

Moore's Portable Riveter.
THE CHICAGO PNEUMATIC TOOL COMPANY.

and known as "Moore's Patent Portable Riveters," manufactured by the Chicago Pneumatic Tool Company of Chicago. The construction of the machine and the method of driving the rivets are shown in the engraving, and the record of the performance is given in a letter from the works, who were the contractors, to Mr. John W. Duntley, President of the Chicago Pneumatic Tool Company. This is a strong indorsement after a very severe test, and it is specially worthy of note that the operation of the machines was successfully intrusted to boys. Notwithstanding the difficulty of the work it was done at a cost of one-fifth of that of hand labor, and the necessity for employing expert boiler makers with the attendant dangers of labor difficulties was avoided. The quality of the work is reported as "far ahead of any work that can be done by hand." The letter is as follows:

"In reference to the use of Moore's patent portable riveters,

we have to state we have used these machines on a contract just completed by us for the Spring Valley Water Company of this city for over 30,000 feet of 44-inch riveted pipe, varying in thickness from $\frac{1}{4}$ to $\frac{3}{8}$ inch. Each machine was operated by two boys, one on the outside of the pipe operating the pneumatic bammer, the other on the inside of the pipe operating the pneumatic holder-on.

"The pipe was shipped from our works in 30-foot lengths, and on account of the hilly country in which the pipe was laid a large number of bands was found necessary in order to make the pipe conform to the ditch. The air was supplied to the machine through a line of 2-inch gas pipe from a compressor attached to a portable boiler on wheels, and the compressor was not shifted until the air line was over 5,000 feet from the compressor to the riveting machines, at which length the loss in the pressure was hardly perceptible.

"Each machine (and we had two on the line) drove 200 $1\frac{1}{2}$ -inch hot rivets per hour. This quantity was not varied in very hilly places, where the machines were operated at an angle of 30 degrees without the slightest inconvenience.

"The cost of doing the work by means of this portable riveting arrangement was but one-fifth of what it cost by hand, not to say anything of the numerous annoyances avoided as regards the labor element. Work of this character has heretofore been confined to boilermakers, who have insisted on the highest wages while engaged on the work, together with their board and lodging, fares and time traveling back and forward from the work. Even with these concessions we have had innumerable strikes from the skilled workmen employed on the job.

"In the case of riveting by portable riveter, the highest wages paid was \$2 per day, and not a skilled man was employed on the work. The rivets driven showed by actual test to be far ahead of any work that can be done by hand.

"THE RISDON IRON & LOCOMOTIVE WORKS."

"San Francisco, Cal., Oct. 4, 1898.

ELECTRIC CAR LIGHTING FOR THE SANTA FE LIMITED.

The "Axle Light" system of the National Electric Car Lighting Company has been selected for use on all the cars of the Santa Fe Limited, running a distance of 2,265 miles from Chicago to Los Angeles. As a result of the satisfactory service given by this system on about 60 cars on this road, extending over nearly two years, the Pullman Company, on September 26, made a contract with the National Electric Car Lighting Company for this application, the first equipments to be ready for service on Nov. 2.

The contract with the Pullman Company is an extensive one. It includes equipments for four complete trains with nearly 5,000 candle-power for each train, besides electric fans and probably also electric lamps for the headlights of the locomotives. Each of the trains consist of three sleeping cars, one dining car, one library car and an observation car. The sleepers have berth lamps, a feature that is very popular with travelers, and electric fans may be used whenever desired. The trains will undoubtedly be as well, if not better, lighted than any others, and this equipment is the most extensive and complete application of the National Company's system of lighting by power from the axles. The light is now being rapidly placed on every car on the Santa Fe which does night service, and five United States mail and express cars, operating on the Gulf, Colorado & Sauta Fe, have also been ordered equipped.

The system of "axle lighting" has been described in these columns, and the company has lost no opportunity and has spared no expense or trouble to improve its system, with a view to rendering its service reliable, and the maintenance and operation of the equipment simple and cheap. Storage batteries are used, but they receive their charges from the axle dynamos, and do not require charging, or changing of position, at the terminals. The regulating apparatus is entirely

automatic, and by a special system of winding the dynamos and arranging the circuits the lighting may be left almost entirely alone while the train is on the road, the lighting circuit switches being practically the only parts requiring attention. That is to say that the lights need only to be turned on or off as required. No current is generated at speeds below about 12 miles per hour, and the current may be used directly from the dynamo to the lamps if desired. The advantage of independence of the lights of each car is urged as a strong claim for the system, and the storage feature renders it possible to light and ventilate the cars when detached from the engine and from other cars. If the equipment of a car is crippled, however, it may be lighted from the next car by means of connecting conductors.

The Los Angeles service is exacting, because it involves round trips of 4,530 miles, with six nights on the road. The reports received are sufficient ground for believing that the system is entirely satisfactory.

Two very severe tests have recently been made with the apparatus of this company. A dining car and a library car were attached to the transcontinental train at Los Angeles, Cal., carrying the Knights Templars to Pittsburgh, Pa., and without any preparation, or, in fact, any previous notice of the trip, these cars, fitted with the National system, were sent out. They had no attention, except for lubrication, and made the trip in good order. The other case occurred with Mr. Depew's private car, which carried him from New York to Omaha and return, a distance of 3,000 miles, with the apparatus that has been in use on the car since last spring. Absolutely no notice was given and no preparation made. Since his return from Omaha Mr. Depew wrote a letter to Mr. Max E. Schmidt, President of the National Company, which we have seen. It expresses entire satisfaction with the lighting and the electric fan systems on this car. This and a similar communication from Mr. E. P. Ripley, President of the Atchison, Topeka & Santa Fe, tend to show that the claims of the company are substantiated.

ACME TRIPLE BOLT CUTTERS.

The machine shown in the accompanying engraving is made by the Acme Machinery Company of Cleveland, Ohio. It is designed especially for manufacturing purposes, with reference

The machines are built in two sizes, known as 1-inch and 1½-inch. They are very compact, and the parts are arranged to be within easy reach of the operator. Holes are provided in the bed directly under each head, allowing the oil and chips to fall in a pan which has a screen bottom and capacity sufficient to hold the chips of the day's work, where they may be left to drain over night and the pan drawn out and emptied in the morning. The carriages are long, giving ample bearing. The long levers move the carriages, and the short ones close the vises and are adjustable to any angle. This makes the movement of both carriages and vises very rapid and easy.

The machine heads are the latest type "Acme," using this firm's well-known form of die, which is made with extra long die-rings, lined, with tool steel blades throughout. The heads are about 5 inches shorter in total length than the usual form of Acme head. The yoke which opens and closes the head is locked by a toggle placed between the lower end of the yoke and the head stock. The upper end of the yoke is connected with a nut that works on a screw having a knurled head, and the dies are thus adjusted to size without stopping the machine, by means of the knurled head screw. The toggle is controlled by a rod passing through a bracket on the carriage; this rod carries two adjustable collars, which are set to open and close the head automatically. The dies are made so that they may be easily renewed by the users. They are constructed in such a way as to insure a good thread, and the builders guarantee them to do so.

The arrangement permits of running the machine as a single, double or triple one at will. Examination of the machines shows that the best of material and workmanship are employed, and the capacity is stated to be one-third greater, with a single operator, than that of any double machine ever built, and at the same time the work is of the best. These objects have not been attained by high speeds of operation, and we are told that the rate of speed is slower than is usual with this class of machinery.

The weight of the inch machine is 3,000 pounds, the

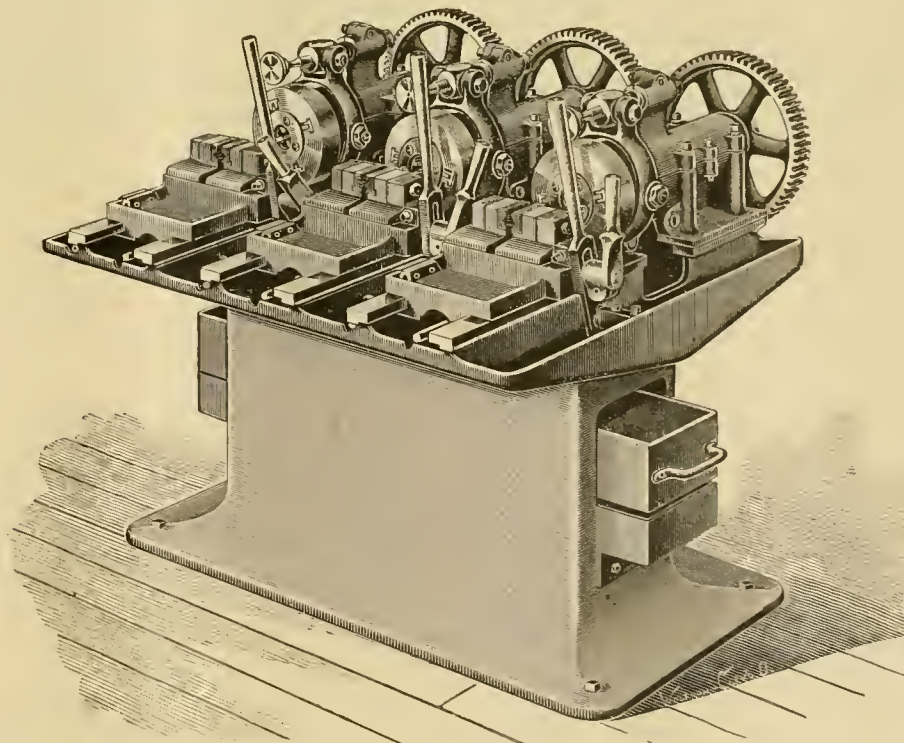

Acme Triple Bolt Cutter.

to producing the maximum output with the minimum care and attention, and the design was made for the purpose of building a machine which shall produce as much work as a single operator is able to handle and still run the machine at a speed which will give it a satisfactorily long life, at the same time doing good work.

floor space required being 4 feet 6 inches by 4 feet 2 inches, and the speed of countershaft 175 revolutions per minute. The weight of the 1½-inch machine is 3,800 pounds, the floor space 5 feet 2 inches by 4 feet 10 inches, and the speed of countershaft 160 revolutions. The manufacture of bolts is a part of the shop work of every railroad, and it is important that it should be carried on on a "manufacturing basis."

WHAT THE RAILWAY CLUBS MIGHT DO.

An idea that has been prominently advocated in the development of the railway clubs is the ultimate utilization of these institutions as a gathering place where members of all branches of railroad service may represent their views and arrive at a more perfect state of harmony on debatable questions than invariably obtains. While such a result might be desirable, there seems to be little promise of its speedy realization and, in fact, at the present time the active members of railway clubs are chiefly connected with the motive power department, and, with a few exceptions, they discuss motive power problems, while still holding out an invitation to other departments to bring forward subjects of mutual interest.

In view of the fact that such organizations as the Signal Club and the associations of track and bridge men afford their members opportunities for discussing the subjects in which they are principally interested, it would appear questionable whether the present railway clubs will ever successfully broaden their field to any great extent, and it is entirely possible that they would attain their highest utility by adhering to the cause to which they have so far been devoted—the exploitation and discussion of motive power department problems. Questions which affect several departments must from their character be generally settled in a railroad office rather than a club.

For some reason probably connected with the character of their work and the variety of methods by which it may be accomplished the representatives of mechanical departments are more willing than any others to devote time to regular meetings, and it cannot be admitted that there is any lack of important subjects for discussion. The mechanical field is broad enough, and in one direction club development has to a large extent been neglected. The literature of the clubs is very valuable and the proceedings have a worth peculiarly their own, recording as they do the experience of the men who are actually engaged in carrying out the operations about which they talk, whereas in many of the technical associations the debaters are men holding positions that are of the directive or executive order, and while the statements of such men, especially as regards problems of a broad or scientific nature, are not to be disparaged, they have the disadvantage of being largely second hand as regards the details that are of such importance in railway work.

The railway clubs thus afford a splendid system for obtaining practical information on any question, but with one exception, that of the discussion of changes in the interchange rules, they have not been systematically used for any purpose. The practical result of this experiment shows that it should certainly be repeated, and it is capable of development into a system of research into many subjects that would not only infuse fresh life and energy into the clubs, but would also prove of the greatest value to the Master Mechanics' and Master Car Builders' Associations.

There are always subjects for committees of the associations on which circular letters requesting information are sent out. Some of these may involve extensive tests or access to tabulated information to enable an intelligent reply to be given; others are of a different nature, seeking rather the united opinion or experience of all who are handling or working with the apparatus to which they refer. In the latter instance it would be difficult to devise a more effective method of inquiry than could be obtained by discussing such questions before the railway clubs. The present circular letters are anything but satisfactory, as can be immediately shown by noting the number of replies received, and while no doubt in many cases a good deal of conscientious research is undertaken, there are also instances where replies are made in a more or less haphazard fashion. Even a Master Mechanic or Superintendent of Motive Power is hardly infallible, and answers may have been made to the best of the respondent's belief when a further inquiry would have developed facts that would have modified his opinions. Now, if information of this description is required, the members of the committee might easily be chosen so that each would be in a position to introduce the subject as a topical discussion before one of the clubs. If put in the form of papers, printed beforehand, with the understanding that each club was expected to do its part in forming the national opinion, there is no doubt that much valuable information could be obtained that is not now obtained at the annual conventions. Each member would feel that he was doing his part in assisting to form the report that would finally be made to the greater association, and this feeling should give an objective point to the proceedings of the clubs and encourage each individual to do his best to bring forward some fact of importance or formulate his experience, knowing that his efforts were not simply wasted or likely to be forgotten, but would occupy their place in the final report according to their worth or reasonableness. The facts brought

forward in this way, if not replacing those obtained from the circular letter, would certainly form a most valuable addition to them and would put the committee in possession of information gathered from wide sources that could not fail to make reports far more representative than is the case at present.

There are not enough subjects that could be handled in this way to seriously interfere with the discussion of questions of immediate or local interest, and as a general thing the difficulty is to obtain papers on suitable subjects. A scheme such as is outlined above might be profitably introduced by collaboration between the secretaries of the clubs and the two associations, and a system that would be a most valuable adjunct to the letter of inquiry might be formulated, which would bind the clubs into an organization that should have a continual reason for existence and prove an encouragement to all to bring forward their individual opinions. H. H. V.

CAR WHEEL IRONS AND THE THERMAL TEST.

The thermal test of chilled cast iron wheels is likely to exert an influence over the manufacture of wheels which renders it desirable to secure all available information on the relations between the tests and the manufacture of wheels. In the July, 1898, issue, page 249, we presented portions of a report by Mr. S. P. Bush, Superintendent of Motive Power of the Southwest System of the Pennsylvania Lines, and some comments upon it contributed by Mr. Guy R. Johnson of Embreville, Tenn., to "The Iron Trade Review" are reprinted as follows:

Chemical Composition of Wheel Irons and the Thermal Test. —In one of our technical journals I notice a report of Mr. Bush, on thermal tests for car wheels. I have read it with much interest, as the furnace of which I am manager makes a specialty of car wheel iron. It is a pity that these tests were not given in a little fuller form. Mr. Bush gives only a group of 20 wheels, 10 of which stood the test, and 10 of which did not stand the test.

From the figures given, Mr. Bush draws the conclusion that there is no evidence of chemical composition to show that the chills of wheels which stand the heat test differ from the chills of wheels which do not stand the test, so far as their properties depend on the chemistry of the metal. It is unfortunate, as I said before, that full chemical analyses were not given. Certainly there is nothing in the tables of carbons furnished to indicate the difference, but may there not have been in some of the other elements?

The result of a great number of experiments carried on at this place, under my supervision, would seem to indicate that both phosphorus and sulphur have a very marked effect on the ability of a wheel to stand the thermal test. We have found that if the phosphorus runs much over .40, the interlacing chill feature, which is characteristic of good wheel iron, is absent—this, with normal sulphur. We have found, though, still further, that high sulphur, i. e., much over one-tenth, has a distinctly deleterious effect on the chill, seemingly neutralizing to a large extent the effect of the low phosphorus in causing an interlacing chill. Furthermore, there are two ways of getting a chill: One, and a correct one, is to use low silicon, low sulphur, and low phosphorus, making silicon the ruling element; the other is to disregard, to a certain extent, both silicon and phosphorus, and obtain the chill by means of sulphur. The latter chill presents one broken and straight line, or demarkation, between the gray and chilled irons.

There is very little question that the strains in the chilled portion of the iron are greater than in the gray. This being the case, unless fingers of chilled metal run down into the gray metal, it is very easy to see that the thermal test would cause the white iron to crack away from the gray.

Without wishing to pose as an authority on the manufacture of wheels, I may add that I have understood from some of the users of this test, that wheels made of the proper kind of metal, with a good interlacing chill, do not yield to the thermal test, but that wheels made with very high sulphur and high phosphorus are exceedingly apt to do so.

The comments by Mr. Johnson were submitted to Mr. Bush and his reply is given as follows:

"I think that Mr. Johnson must have overlooked some things in my report. In the first place, he states that it is unfortunate that the chemical analyses were not given in full. You will notice, however, by examining a copy of my report, that the full analysis of the gray iron is given.

"With one or two exceptions, there is not sufficient difference in the other elements, besides carbon, between the wheels that stood the thermal test and those that did not, to warrant the supposition that these other elements are responsible for a wheel standing the thermal test, or not, as the case may be. The only element in all of the analyses of the gray iron that does vary much is that of the combined carbon, and this element is marked as between those that stood the thermal test and those that did not, and the particular point that my re-

port was intended to bring out was that while there may be a difference in the carbon in the gray iron, yet this difference disappears in the chill, and as a result of this disappearance, it is fair to presume, so far as chemical analysis is concerned, that the wear of the chill will be the same. This point is brought out to controvert the theory advanced by some wheel makers that if wheels are manufactured to stand the thermal test, they must have a smaller quantity of combined carbon, and this being the case the durability of the chill would be impaired. It only remains now for the advocates of such a theory to demonstrate the incorrectness of the conclusions deduced in my report."

TEN-WHEEL FREIGHT LOCOMOTIVES—MISSOURI PACIFIC RAILWAY.

The Rogers Locomotive Company have completed 15 freight locomotives of the single expansion, ten-wheel type for the Missouri Pacific Railway, for use on the St. Louis, Iron Mountain & Southern, one of which is illustrated in the accompanying engraving. The following table gives the principal dimensions:

Fuel.....	Bituminous coal
Cylinders.....	20 by 24 inches
Drivers, diameter.....	60 inches
" material.....	Cast steel
Driving wheel base.....	32 feet 6 inches
Total " ".....	23 feet 4 inches

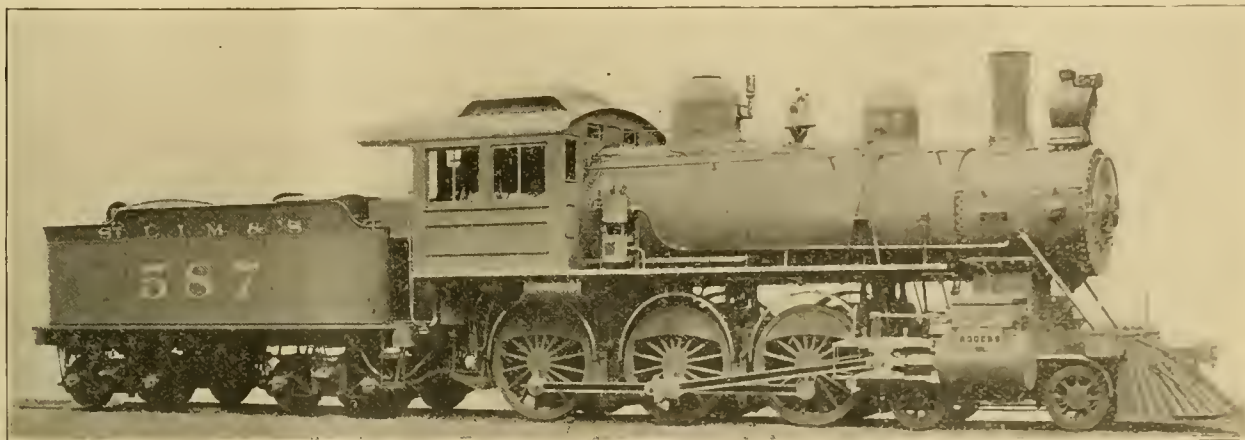

Rogers Ten-Wheel Locomotive—Missouri Pacific Ry.

Weight on drivers.....	109,700 pounds
" truck.....	36,000 pounds
" total.....	145,700 pounds
Heating surface, tubes.....	1,953 square feet
" firebox.....	156 square feet
" total.....	2,109 square feet
Grate area.....	28.8 square feet
Tubes, diameter.....	2 inches
" length.....	13 feet 5 inches
" number of.....	278 inches
Grates, length.....	102 inches
" width.....	40 1/2 inches
Boiler.....	Extended wagon top
" diameter front end.....	60 inches
" thickness of barrel.....	5/8 inch
" " dome course.....	21-23 inch
" " crown.....	5/8 inch
" " tube sheet.....	1/2 inch
" " sides.....	1/2 inch
Truck wheels.....	30 inches
Tender, water capacity.....	4,000 gallons
" frame.....	10-inch channels
" trucks.....	Diamond
" " bolster.....	Cast steel
" wheels, diameter.....	33 inches
" kind.....	Ramapo

The special equipment includes two 3 inch Coales safety valves, No. 9 Nathan triple sight feed lubricators, Westinghouse and American brakes, Janney couplers, Midvale steel tires, Friedman non-lifting injectors by Nathan & Co., and National hollow brake beams.

The Oil City Derrick reports that the total production of Pennsylvania oil for the first nine months of the present year, as shown by the pipe line runs, has been 23,538,185 barrels, or 86,220 barrels a day, as compared with 34,724,684 barrels, or a daily average of 95,136 barrels, in 1897. The daily average this year is, therefore, 8,916 barrels below that of last year.

CONSOLIDATION OF MASTER CAR BUILDERS' AND MASTER MECHANICS' ASSOCIATIONS.

The subject of the consolidation of the Master Car Builders' and Master Mechanics' Associations was discussed at the September meeting of the Northwest Railway Club, and was introduced in a paper by Mr. J. H. Goodyear, Chief Clerk in the Motive Power Department of the Chicago Great Western Railway. Mr. Goodyear argued that the Master Car Builders should not consent to the consolidation, and stated that the good work was formed of officers who were not representative car men that the membership of the M. C. B. Association last year, were good reasons for keeping the organizations separate. The membership was made up as follows: Master Car Builders, 30 per cent.; Assistant Superintendents of Motive Power, 5 per cent.; General Superintendents, 1 per cent.; Superintendents of Motive Power or Master Mechanics, and Foremen, 20 per cent.; Mechanical Superintendents, 20 per cent.; 24 per cent. being represented by men on roads too small to have separate officers at the head of the car department. The general officers were not representative car men, and in this consolidation the Master Car Builders would be lost sight of. Another argument was that there was a tendency to place

engine men, car men and roundhouse forces under the charge of the officers of the transportation department, which was not to be desired. These views were answered by Mr. Tracy Lyon, Master Mechanic of the Chicago Great Western, and his statements are so clear and so good that we print them nearly in full, as follows:

I will take issue with the statement that 41 per cent. of the Master Car Builders' Association are locomotive men. The term "locomotive men" is entirely a misnomer. Those called locomotive men take as much interest in and have as much responsibility for the cars as they have for the locomotives; simply because they are Superintendents of Motive Power, Mechanical Superintendents or General Master Mechanics does not make them locomotive men pure and simple. They are responsible to their managers just as much for the cars and for the painting of the cars as they are for the locomotives and their operation.

The consolidation of the Master Mechanics' and Master Car Builders' Associations would seem to be in the direction of centralization and a decrease in the friction of business, and, therefore, it is bound to come. It seems to me that the objections offered to the consolidation of these two associations are more in the form than the substance. Certainly no one has a right to belittle the work done by the Master Car Builders' Association, and I certainly do not wish to do so. It has fulfilled a most valuable function. At the same time it is certainly open to question whether this same amount of work cannot be done in not only a more expeditious manner, but in a better way for the health of the railroads as a whole.

I would call the attention of those who have spoken in disfavor of the consolidation to the fact that the present M. C. B. code of rules governing the interchange of cars as they stand to-day, and their development in the last two years, are almost entirely the results of the efforts of the so-called "locomotive men." The principle of the present code of rules, throwing upon the owners of the cars the responsibility for their running re-

pairs, originated a few years ago with half a dozen such men. We called it first the "Chicago agreement," and operated under this agreement for a year as a matter of trial. The first year that such a change was proposed to the Master Car Builders' Association it failed to carry. The second year it carried after considerable hard work on the part of those who were interested in it. Therefore, it would certainly seem that the so-called locomotive men are not without interest in the principal work of the Car Builders' Association. The interests of the two associations are so closely allied and interwoven that it seems a waste of power to separate them. So far as the representation of the Master Car Builders themselves in a general association representing the rolling stock of the United States and Canada is concerned, there is no reason whatever why the Master Car Builders should not be represented as well as the Superintendents of Motive Power and Master Mechanics, and should not have every opportunity for expressing themselves and taking an active part in the proceedings and deliberations. At the same time I think that there are few Mechanical Superintendents who would be willing to intrust to another, even to their own assistants, in fact, the deciding vote in matters pertaining to the interchange of cars, or any other important question concerning the handling of cars, inasmuch as they are the ones who are directly responsible for the result.

At the same time if the Master Car Builder or General Car Foreman, or whoever represents the car department of a railroad, were to attend these conventions with the head of the mechanical department, the latter would have the advantage of his advice, and the Master Car Builder would have every opportunity, as I have said, to take part in the discussions.

The subject of the interchange of cars should not be considered as an art in itself. To those who are specially interested in it the inspection of cars is almost too likely to be considered as a fine art, while as a matter of fact it is merely a means to an end. We have been trying for several years to simplify the inspection of cars and to reduce the labor involved in it to a minimum, and this special agreement of which I have spoken, and the radical changes in the present code of rules brought about by "locomotive men" have been in that direction.

Mr. Goodyear says that unless active steps are taken in a few years the absolute control of engine, roundhouse and car men will be in the hands of train superintendents. That is something I should be rather glad to see. A railroad is not operated for the privilege of inspecting cars or operating roundhouses. The purpose of a railroad is to move freight and passengers. The other things are simply the tools to this end, and they should be handled as such. I believe that before very long the strictly operating part of a railroad, including the control of engine, roundhouse and car men, will be more entirely in the hands of the superintendent, and that the function of the mechanical man will be more in the way of a consulting engineer. As it is now, he is retained practically by the railroad as an expert, yet he has, as such, too much to do with the actual traffic of the railroad. He might accomplish more if he had more leisure to consider quietly the larger problems of the improvement in cars, motive power, fuel handling and consumption, machinery and everything that pertains to the maintenance and operation in itself of the rolling stock and the shops.

PROTECTION OF BRIDGES FROM SALT WATER DRIPPINGS.

The recent action of the Master Car Builders' Association in recommending methods of protecting bridges from the destructive action of brine drippings from refrigerator cars was recorded in our issue of July of the current volume (pages 220 and 246). The Association of Railway Superintendents of Bridges and Buildings at the recent convention considered the subject from the standpoint of those who maintain the bridges. The following paragraphs from the report of a committee gives their views, which are in accord with those of the Master Car Builders:

"That this dripping is very injurious to metal none will question, except perhaps, the owners of refrigerator cars. Some little interest is being taken in this subject by the officials in charge of track and bridges, but little or none by those in charge of the transportation departments, and while the remedy should be applied to the cars instead of the bridges, there will undoubtedly be opposition to this method by the car owners, who will probably be very slow to provide their cars with the necessary protection unless forced to do so by the railroad companies' united action.

"One refrigerator car will produce probably 200 gallons of brine every 24 hours, which is distributed over the roadbed and bridges as the car passes along or is held on a siding. The damage is greatest when these cars are not in motion and on curves where slow speed is maintained. In order to protect bridges in such places, it would be necessary to completely cover their decks with a waterproof protection, with gutters to carry off the brine. This is rendered necessary because the vents in the present refrigerator cars vary in their positions, thereby making it impossible to construct a simple gutter to catch the flow.

"It has been suggested that attachments be made to all cars

in such a manner that the flow of brine will always fall in the center between the rails. This will furnish considerable relief and in places where the flow is excessive, provision could be easily made to catch this flow and conduct it away from mtal work. The attachment to the cars would probably not cost more than \$5 each, and would be a compromise between the railroad companies on the one side providing a waterproof decking for the structures mostly damaged, and the owners of the cars on the other side providing reservoirs to hold this dripping until discharged at regular stations."

FAILURES OF AIR BRAKE HOSE.

Air brake hose failures from bursting occur at the rate of from eight to ten cases per day on the Lake Shore & Michigan Southern Railway. These figures are from carefully kept records. The bursting of hose is not always accompanied by wrecks and damage, but it is likely to be, and the quality of hose is clearly an important matter. There is no reason to believe the failures on the Lake Shore from this cause are higher than on other roads, but the records are probably most carefully kept.

The cost of splicing air brake hose by the use of a malleable iron thimble casting and the clamps necessary for making tight joints is 7 cents. This price and the fact that the practice was considered entirely safe and commendable was brought out in a recent discussion before the Western Railway Club. The practice is followed by several roads for their own cars, but not for repairs to foreign cars. It was shown to be necessary to test the hose under about 100 pounds pressure to insure tight joints. Out of a total of 40,293 pieces of hose in use on the Chicago, Milwaukee & St. Paul last year there were 6,323 failures, including all causes. Of these 2,766 were spliced and returned to service, about 15 per cent. of the total number in service failed, and the total number that failed after splicing was 14 per cent. of the total number spliced.

The failures of brake hose on the Chicago, Milwaukee & St. Paul Railway for the year ending June 30, 1898, were reported in the proceedings of the Western Railway Club September, 1898, in the following concise form:

CHICAGO, MILWAUKEE & ST. PAUL RAILWAY CO. REPORT OF FAILURES OF AIR HOSE FOR FISCAL YEAR ENDING JUNE 30, 1898

EQUIPPED WITH AIR BRAKES	
Locomotives.....	729
Passenger cars.....	771
Freight cars.....	16,782
Total.....	18,282

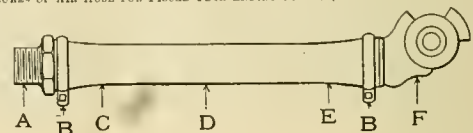

FIG. 2.

DEFECTS FOR WHICH AIR HOSE ARE WITHDRAWN FROM SERVICE

- | | |
|--|--------------------------|
| 1 Burst at C. | 9 Broken clamp bolt, B. |
| 2 Burst at D. | 10 Broken clamp bolt, B. |
| 3 Burst at E. | 11 Loose fittings. |
| 4 Cracks through rubber at C, exposing canvas. | 12 Pulled in two. |
| 5 Cracks through rubber at D, exposing canvas. | 13 Crushed. |
| 6 Cracks through rubber at E, exposing canvas. | 14 Chafed. |
| 7 Damaged to nipple, A. | 15 Cut |
| 8 Damaged to coupling, F. | |

Note.—Defects caused by kinks must be shown in column of figures in prime, thus 1%, 2%, 3%, etc.

MAKER	KEY															Total Required for Replacement.														
	1	1'	2	2'	3	3'	4	4'	5	5'	6	6'	7	7'	8		8'	9	9'	10	10'	11	11'	12	12'	13	13'	14	14'	15
Spliced hose.....	69	91	31	28	34	7	1	3					1	3					1	13	1	10			1	49	189	15	45	532
Miscellaneous.....	172	235	58	96	149	30	3	18	9	10	8			3	33	3			10	196	704	79	219			26	4	13	2659	
Total.....	241	326	89	124	183	37	4	27	12	20	16	8	1	4	36	3	10	10	206	800	78	238	26	45	31	51	14	58	2691	
Total.....	526	791	246	247	435	97	13	54	23	26	16	1	11	122	11	32	22	625	2109	204	769	6323							6323	

Number of hose spliced, 2,766.

GASOLINE AND GAS ENGINES FOR RAILROAD PUMPING STATIONS.

The prevailing method of pumping water into elevated tanks for use of locomotives is to install a steam pump and boiler at or very near the source of supply, and place the outfit in charge of a man who looks after and operates it. The selection of pumps is often neglected, and that of boilers more so, until, as a rule, the pumping equipment is anything but efficient and economical. The necessity for distributing fuel to these plants and the troublesome question of repairs are to be added to the expense of operation, making them rather unsatisfactory, but of late the application of gas and gasoline engines to this service has begun to attract attention. The advantages offered by them are worthy of consideration. While a large proportion of these plants are located in the vicinity of supplies of city gas, many of them are at outlying points along the road, and either gas or gasoline engines may be used to meet all of the conditions. These en-

gines may now be considered as reliable, and they require no more care and no higher order of intelligence in operating than is usually given to the steam plants. The fuel is easily handled, is automatically fed, and there are no ashes. Gas engines require attention in starting, but they may be allowed to regulate themselves afterward, and therefore require much less care than steam apparatus. In some cases the station attendants teach men or give them all the attention they require.

An interesting paper on this subject, read before the Engineers' Society of Western Pennsylvania, contains valuable information and suggestions applicable to railroad water stations. About two years ago an auxiliary pumping station was installed at Pitcairn in connection with the East Pittsburgh Water Works, and a gas engine was decided upon for the following reasons: Gas supply was available from the city mains, this form of engine was always ready for work and did not require banked fires, the cost of putting in a boiler plant and the expense of handling coal and ashes was saved, and, finally, the pump could be automatically controlled. A triplex 8½ by 8 inch single acting pump was selected which was guaranteed to pump 225 gallons per minute against a head of 325 feet with an expenditure of 25 horse power, the engine being guaranteed to give 25 brake horse power for a consumption of 15 cubic feet of gas per horse power per hour. The actual consumption was only 13.42 cubic feet. Records are given of gasoline engines working on a consumption of one-third and four-tenths of a gallon of gasoline per horse power per hour, and the author of the paper shows that the fuel consumption of small engines bears a close relation to the duty when compared with larger units. These examples were selected from several given by the author, and the paper should be read by officers who have pumping plants in charge. One of the strongest recommendations of gasoline and gas engines is that the fuel consumption ceases when the engine stops, they may be started without delay due to banked fires, and one man may attend several of them.

Old ideas as to fine art in painting locomotives and tenders are giving place to practicable and serviceable ones. The "Railroad Gazette" says that the New York, Chicago & St. Louis has found that considerable saving can be made over the present methods of painting and lettering locomotives and tenders. This road now paints the tenders with asphaltum applied with a broad brush, while the letters and numbers, instead of being made on the tenders and locomotives themselves, are painted on wooden sign boards, which are held in place by bolts. In this way all the lettering can be done in the paint shop, while the engine and tender are undergoing repairs, so that the locomotive is not kept out of service several days while being lettered. Mr. Mackenzie, the Superintendent of Motive Power, states that in this way the painting costs between \$30 and \$35 less for each locomotive than it did formerly.

PERSONALS.

Mr. E. C. Palmer, Secretary and General Manager of the Standard Tool Company, of Cleveland, died Oct. 13.

Mr. James Carmichael, Superintendent of the Machinery Department of the Harlan & Hollingsworth Company, is dead.

Mr. E. D. Jameson has been appointed Assistant Master Mechanic of the Western Division of the Grand Trunk, with office at Battle Creek, Mich.

Mr. F. B. Goodrich has been appointed assistant engineer of the Houston & Texas Central, with headquarters at Houston, Tex.

Mr. F. W. Gilcreast has been appointed Division Engineer of the Mahanoy and Hazleton division of the Lehigh Valley, with office at Hazleton, Pa.

Mr. Henry Pape has been appointed chief engineer of the water lines of the Oregon Railroad and Navigation Company, in place of Mr. Reuben Smith.

Mr. Robert Carritt has been appointed Chief Engineer of the Mississippi Valley Railway, with headquarters at 806 Chestnut street, St. Louis, Mo.

Mr. Alfred Lovell has been appointed Assistant Superintendent of Motive Power of the Northern Pacific. He was formerly Engineer of Tests of the road.

Frank C. Doran, Engineer and General Roadmaster of the Chicago & Western Indiana and the Belt Railway of Chicago, died at his home in Chicago October 15.

Mr. J. W. Patten, Chief Clerk to the Second Vice President of the Erie, has been appointed Assistant Purchasing Agent of that road, with headquarters at New York.

Mr. J. D. Trammell has been appointed Chief Engineer of the International & Great Northern, with headquarters at Palestine, Tex. He was formerly Resident Engineer.

Mr. J. E. Price, district superintendent of the Intercolonial Railway at Truro, N. S., has been appointed general superintendent of that road, with headquarters at Moncton, N. B.

Mr. William H. Clark has been appointed General Manager of the Lowell & Hastings, in addition to his previous duties as Traffic Manager. He has held the last-named position since 1890.

Mr. L. H. Hilton resigned as President and General Manager of the Sylvania Railroad at the annual meeting in Sylvania, Ga., September 29, and M. P. Daffin was chosen president and treasurer.

Mr. C. A. Delaney, formerly Superintendent of the Richmond Locomotive and Machine Works, Richmond, Va., has been appointed Superintendent of the Dickson Locomotive Works, Scranton, Pa.

Mr. Gustave R. Tuska, Chief Engineer of the Panama Railroad Company, has also been appointed Consulting Engineer to the American Representative of the Russian Government in connection with the Chinese Railroad system.

Mr. W. H. Russell, traveling engineer of the Southern Pacific, between Bakersfield, Cal., and El Paso, Texas, has been appointed assistant master mechanic of the road at Oakland, Cal., and Mr. Jesse C. Martin has been made traveling engineer.

Mr. B. S. Snyder, foreman of the roundhouse of the New York, Chicago & St. Louis at Conneaut, O., has been appointed Master Mechanic of the Columbus, Sandusky & Hocking, with headquarters at Columbus, O., vice Mr. T. M. Downing, resigned.

Mr. Joseph A. West, Secretary and General Freight and Passenger Agent of the Sumpter Valley Railway of Oregon, has accepted the position of Chief Engineer of the Utah & Pacific, which is to be built from Milford, Utah, to the Nevada State line, 75 miles.

Mr. Andrew G. Wilson, Superintendent of the machine shop of the Harlan & Hollingsworth Company, Wilmington, Del., has resigned after a service of 36 years to accept a position as manager of the Maryland Steel Company's ship yard at Sparrow's Point, Md.

Mr. J. S. Chambers, formerly Master Mechanic of the Illinois Central at Paducah, Ky., has accepted the position of Superintendent of Motive Power of the West Virginia Central & Pittsburg, with headquarters at Elkins, W. Va., to succeed Mr. J. S. Turner, resigned.

Mr. Paul J. Myler, Secretary of the Westinghouse Manufacturing Company, Ltd., at Hamilton, Canada, will succeed George F. Evans as Manager when Mr. Evans leaves for St.

Petersburg, Russia, to establish a plant for the manufacture of brake apparatus in Russia.

Mr. M. F. Bonzano, whose resignation as Superintendent and Chief Engineer of the Columbus, Sandusky & Hocking has been announced, has become General Manager of the Chattanooga Southern, a position which he held before taking the one from which he now resigns.

Mr. George H. Kimhall, formerly Superintendent of the Eastern Division of the New York, Chicago & St. Louis, has been appointed Superintendent and Chief Engineer of the Columbus, Sandusky & Hocking, with headquarters at Columbus, O., to succeed Mr. M. F. Bonzano, resigned.

Col. D. S. Wagstaff, of Detroit, Mich., General Northern Agent for the Cincinnati, Hamilton & Dayton, has been appointed representative of the Detroit White Lead Works and Detroit Varnish Company. Col. Wagstaff was formerly connected with the passenger departments of the New York Central, West Shore and Grand Trunk roads.

Mr. J. J. Donovan, Vice President and General Superintendent of the Bellingham Bay & Eastern, has also been appointed General Superintendent of the Bellingham Bay & British Columbia, with headquarters at New Whatcom, Wash., in place of Mr. C. L. Anderson, who has been General Superintendent, Chief Engineer and Purchasing Agent.

Mr. F. E. Wittekin, formerly Chief Engineer of the Sinnemahoning Valley and afterward Chief Engineer of the Kishacoquillas Valley Railway, has been appointed Consulting Engineer and Technical Director of the Government railroads of Colombia, South America, of which he has been Chief Engineer since February 1, 1896. Headquarters, Medellin.

Mr. John Lundie, M. Am. Soc. C. E., has been appointed Consulting Electrical Engineer of the Brooklyn Elevated Railroad. He has given a great deal of attention to matters connected with the substitution of electricity for steam on railroads and for some time has been retained by the Illinois Central for this work. His New York office is 71 Broadway.

Mr. H. Frazier, late Chief Engineer of the Chesapeake & Ohio, has been appointed Chief Engineer of the railroad to be built from Canton to Hankow, China, by the China Developing Company. Mr. Frazier was Chief Engineer of the Chesapeake & Ohio from July 1, 1891, to June 1 of the present year, when he resigned, and previous to 1891 was Superintendent of the Huntington and Cincinnati divisions of the same road.

Mr. Thomas A. Fraser, Superintendent of the Wells & French Car Shops, shot himself at his home in Chicago on October 13, dying instantly. Illness and consequent despondency was given as the causes leading him to take his life. Mr. Fraser was widely and favorably known through his connection with the Wells & French Company, and also formerly as Master Mechanic of the Minneapolis, St. Paul & Sault Ste. Marie Railway.

A. W. Stedman, formerly for many years chief engineer of the Lehigh Valley Railroad, died at Mauch Chunk, Pa., October 7. He was born at Mauch Chunk in January, 1844, and entered railway service March 4, 1861, as telegraph operator on the Lehigh Valley. Two years later he entered the service of the engineering department of the same road, and worked three years as levelman, when he was appointed assistant engineer. After holding the latter position for 15 years, he was for two years principal assistant engineer, and was appointed chief engineer in 1883. He retired from the last named position in March, 1893, but continued as consulting engineer of the road.

Mr. L. C. Burgess, one of the best known railway supply men, died at his residence, near Chicago, Oct. 3, after an illness of several months. He was born in 1847 at Hancock, N. H., and went to Chicago in 1875 as head of a department of the works of Wheeler & Wilson Sewing Machine Company. He was afterward in the business of manufacturing bolts and a member of the firm of Schumway & Burgess. His connection with the railway business began as a representative of the Ajax Forge Company, and afterward he was connected with the Terre Haute Car & Manufacturing Company, and later was General Manager of the Muskegon Car Company. When the National Hollow Brake Beam Company was organized he returned to Chicago and was given charge of the sale department, and was connected with that concern up to the time of his death. Mr. Burgess had a great many friends, and among the closest of them were those with whom he was associated in business.

Frank F. Hemenway, who was well known as one of the editors of the "American Machinist" for fourteen years and also as the author of an excellent book on the steam engine indicator, died in Brooklyn October 14. He was a thorough mechanic and served as such in a number of manufacturing and railroad shops. He experimented with and assisted in the development of the Richardson pop safety valves and the Richardson balanced slide valve, as well as designing the Hemenway automatic cut-off engine, which, however, was not a permanent success. As a writer he began to contribute to the columns of the "American Machinist" in 1879 and became associate editor in 1881. On the death of Jackson Bailey, in 1887, he became editor and held the position until his resignation in 1894. The "American Machinist" says of him: "His information was wide and marvelously correct, and his judgment more than kept pace with it. The word that came from his pen or his tongue was never misleading. Personally he was a true friend. He was kind and actively helpful to all with whom he was associated. He did good and not evil all his days to all he met in the walks of business."

BOOKS AND PAMPHLETS.

"A Handbook of Engineering Laboratory Practice," by Richard Addison Smart, M. E., Associate Professor of Experimental Engineering, Purdue University. 12mo.; cloth, 290 pp., illustrated. John Wiley & Sons, New York, 1898. Price, \$2.50.

This little book is to be commended for the excellent arrangement of subjects presented, and for the concise character of its descriptions. While intended primarily as a manual for the use of students in technical schools, it will prove suggestive to many engineers in active service, and especially useful to those who, from force of circumstances, have failed to keep in touch with modern laboratory methods. Methods and apparatus employed in proving the accuracy of such instruments of observation as are commonly used in engineering work are briefly but accurately described, and the course to be followed in investigating the performance of machinery of many kinds is carefully outlined.

The book contains thirteen chapters, besides an introduction, the heads of which are as follows: "Elementary Measurements, Measurement of Liquids, Measurement of Gases, Measurement of Pressure, Measurement of Temperature, Calorimeters, Measurement of Power, Strength of Materials, Steam Boiler Testing, The Steam Engine Indicator, Steam Engine Testing, Testing of Hydraulic Machinery, Miscellaneous Tests." While much of this work necessarily follows lines previously defined, the book presents ample evidence of combinations of apparatus and of methods not before published. It ends with a very complete index, a feature which is too often entirely omitted or left incomplete in the modern engineering handbook.

A good start has been made by the author in this work, and he should be encouraged to elaborate and enlarge it in future editions. In the interests of railroad men and stockholders as well, the author is urged to tell what he knows about the testing of a locomotive, and we hope this edition will sell so well as to give him the opportunity in the near future.

"The Story of American Coals," by William Jasper Nicolls, M. Am. Soc. C. E.; octavo, 405 pp. J. B. Lippincott, Philadelphia, 1897.

This book is intended for those who wish to know about coal without looking through several books. The arrangement of subjects is logical. It begins with the origin of coal and its development, and follows the various paths whereby it reaches the consumer and tells of the different uses to which it is put. It is a story, told in an interesting way, and is so well indexed that it is also a reference book. It is devoted entirely to American coals, of which \$200,000,000 worth are mined annually. The author has prepared himself for his task by fifteen years' work in the Pennsylvania coal regions, much of the information having come from his personal experience. The chief subdivisions of the subject are: Origin, development, transportation and consumption. Theories of origin, the various methods of mining and the transportation problems, together with the study of combustion, the important question for the future of the industry, and a discussion of the uses of coal for steam, gas and coke making, constitute a wide field and it is well covered. The story is admirably written in a very simple, enjoyable style. A great many statistical figures are given and the work is altogether a satisfactory one. Such matters as smoke prevention and the use of the Wegener system for burning powdered coal and the causes of spontaneous combustion are to be found in the book. The author has a proper appreciation of the industrial importance of coal and shows the intimate and inseparable relations between coal supply and railroad and water transportation. The publishers have done their part handsomely. The binding and the paper are good, and the large type and excellent typographical features are praiseworthy.

"La Machine a Vapeur." By Edouard Sauvage, Professor a l'Ecole Nationale Supérieure Des Mines. Baudry & Company, Paris, France. 2 vols.; 468 pp.; 1,036 illustrations.

So much has been written and some of it has been so well written that it would seem unlikely that there was much room for any additional text books or treatises upon the steam engine. At the first sight the book under review presents a very imposing and attractive appearance. The type is large and clear, the presswork has been well done and the paper is of a fair quality, but upon a careful examination of the treatise one is led to the inevitable conclusion that the creation of scientific treatises by compilation is not exclusively confined to this country. The arrangement of the matter in the book is rather curious and leads one to the suspicion that the compilation process has been carried almost to an extreme. For example, the first chapter opens with the description of the essential organs of the steam engine. The opening paragraph says that "fuel burned in a firebox heats water which partially fills a boiler. The heat transforms water into steam which exercises a pressure against the walls of a cylinder." The next sentence states that "most engines have at least one cylinder in which a piston moves, as an essential part." After describing in a desultory way the various parts of a steam engine, including a surface condenser, the old mining engines of the last century, slide valves, the general form of horizontal engines, with numerous illustrations of types of compound and triple expansion engines, in none of which is there a really adequate description, the second chapter opens with physical and mechanical laws. In this the professor appears, and it is scientific in the highest degree if diagrams and equations constitute or insure scientific accuracy. This is followed by a chapter on the work of steam, in which indicators and their functions are extensively described and illustrated, as well as dynamometers, and this in turn is followed by the theoretical cycles of the work of steam and the action of the walls of the cylinder in producing internal condensation. The illustrations throughout are fair, but are not printed with the distinctness which the reader has the right to demand. Many of them bear the evidence of being reproductions from previous engravings, and this is especially true of the wood cuts. It is difficult to understand the system upon which the book has been compiled, for a compilation it most assuredly is. There is no clearly defined method of treatment.

Valves of all sorts and descriptions are illustrated and very briefly described, but it is well within the limits of truth to say that for a man unacquainted with the art it would be

impossible to lay out a single one of the many valve motions described, from the information given him in the text.

The book, as has been said, is largely a compilation taken from periodical publications, builders' catalogues and previous works on the steam engine which have, in course of time, found their way to the pigeon holes of the author to be taken out and put together in the compilation before us. Like other compilations of this sort where an attempt has been made to do a great deal within a very small space, the result has been desultory work in many particulars. The book is a treatise on the steam engine, and it handles not only the stationary engine, but the locomotive, marine and traction engine as well.

The most satisfactory portion of the book is that devoted to tubular boilers, not that the text or the suggestions to be derived from it can claim any very great amount of originality, but because the illustrations are very complete and give a clear idea of the various methods of boiler construction that are now in use, and which can be shown by illustrations as well as by the text. As a final illustration of the mixture or lack of order of the book, we will state that in one single chapter we have tubular boilers, boiler construction, bracing, riveting, method of making laps, water tube, marine, locomotive boilers, water testing, injectors and water purifiers, to say nothing of such minor matters as water gauges, stop cocks, safety valves and steam gauges.

The principal value of the book, then, may be said to lie in the large number of illustrations which it contains and the most excellent index which accompanies it. There is not only a complete alphabetical index referring to all parts of engines that are mentioned or treated, but there is a list of authors and their works from which quotations have been made. In addition to this, there is a regular table of contents which is thoroughly well amplified. This part of the work has been most excellently done, and can well serve as an example to any author who contemplates either the compilation or the writing of a new book on scientific subjects.

"Proceedings of the Thirty-second Annual Convention of the Master Car Builders' Association. Held at Saratoga, New York, June, 1898."

The volume before us is uniform with those recently issued by the association, and besides the proceedings contains the usual information, such as a list of members, constitution and drawings of the standards and recommended practices. The larger portion of the book is devoted to the reports of committees and the deliberations and discussions of the convention of the past summer. The large folded plates containing the standards of the association have been improved by captions which may be seen without unfolding the plates. This feature is a commendable one, and the selection of the drawing wanted may be very easily made. The volume has appeared with the usual promptness of the Secretary, Mr. Cloud. He and his assistants deserve credit for handling such a large amount of work so quickly.

"Soft Coal Burning," by C. M. Higginson. Fifth edition. Printed by the Railway Master Mechanic, Chicago, 1898.

This is an 18-page illustrated pamphlet devoted to a study of the proper method for burning soft coal in stationary and locomotive boilers. Mr. Higginson, who is now assistant to the President of the Atchison, Topeka & Santa Fe Railway, has given a great deal of attention to this subject, and has been exceedingly successful in applying the methods he describes. We have watched this pamphlet through its five stages of development, and consider it an excellent treatise, although very brief, and it is hoped that it will continue to grow and gain wide distribution. One of the most important of the points made in it is the necessity for compelling intimate mixture of the products of combustion and oxygen, coupled with provisions for obtaining complete combustion before the flames are extinguished by contact with relatively cool surfaces. The author has the secret of smokeless and efficient combustion. He considers the subject of heating surfaces in locomotives, and suggests the use of corrugated tubes to break up the streams of the products of combustion and thereby increase the evaporative efficiency. The author's ideas have been repeatedly expressed in our columns. He lays no claim to original discovery in the matter of coal-burning, but records the results of methods and experiments covering a long period, the applications of which have been very satisfactory.

"Twelfth Annual Report of the Commissioner of Labor, 1897; Economic Aspects of the Liquor Problem." Government Printing Office, Washington, 1898.

"Professional Papers of the Corps of Royal Engineers," (England). Edited by Captain R. F. Edwards, R. E., 1897. Published by the Royal Engineers' Institute, Chatham, England, 1897; price 10s. 6d.

Catalogue of the Michigan College of Mines, 1898. With Statements Concerning the Institution and Its Courses of Instruction for 1898-1900. Published by the college, Houghton, Michigan, August, 1898.

Bulletin of the University of Wisconsin No. 26, Containing an Address by Mr. Onward Bates, Engineer and Superintendent of Bridges and Buildings, Chicago, Milwaukee & St. Paul Railway.

"The Journal of the Association of Engineering Societies" for August contains three papers on the abolition of the grade crossings on the main line of the Boston & Albany Railroad in Newton, Mass., by Messrs. Irving T. Farnham, William Parker and W. G. S. Chamberlain, of the Boston Society of Civil Engineers; and one on power consumption on electric railroads, by S. T. Dodd, of the Civil Engineers' Club of Cleveland. In the first series of papers Mr. Farnham deals with the history of the improvement and with the street and drainage work connected with it; Mr. Parker with the depression of the railroad tracks, and Mr. Chamberlain with the bridges over the tracks. All the papers are freely illustrated. Mr. Dodd, in his paper, gives a scholarly analysis of the several items of work performed by the electric current on railroads, and illustrates his paper by diagrams giving speed, torque and acceleration curves.

"History of the Railroad Ticket." This is a 22-page pamphlet by the Rand Avery Supply Company of Boston. The author, Mr. Robert S. Gardiner, with the assistance of colored reproductions of tickets, outlines the great advancement which has been made in the printing of railroad tickets since 1836.

"Coupler Computing Tables."—This is a pamphlet containing a table of information about M. C. B. couplers. It is standard size and gives a list of couplers, the weight of material in each, and the original and scrap values. Its object is to facilitate the work of billing for couplers and their parts. It is compiled and published by Messrs. G. W. Glick and John H. Nichols, of Cleveland, Ohio.

"Electric Street Railway History," Part I, is a 40-page illustrated pamphlet received from the Westinghouse Electric & Manufacturing Company. It contains a review of the development of Westinghouse railway motors with references to generating apparatus and brief remarks on the possibilities of the future. The pamphlet shows why this company has led and now occupies the leading position in electric railway work.

The standards and recommended practice of the Master Car Builder's Association as revised by the last letter ballot, may be had in pamphlet form from Mr. J. W. Cloud, Secretary, 974 The Rookery, Chicago, at 25 cents per copy. The large sheets of drawings, 30 by 38 inches, corrected by the ballot may be had at 25 cents each. The revised air brake and signal instructions, and the rules for loading long materials are also available in pamphlet form.

Magnolia Antifriction Metal and Camella Bronze are described in a 38-page illustrated pamphlet issued by the Magnolia Metal Company, 74 Cortlandt street, N. Y. This pamphlet contains much that is interesting to those who use bearings and as a source of information in regard to the comparative merits of different "anti-friction" metals it is worthy of careful consideration. The records of tests by the Bureau of Steam Engineering, U. S. Navy Department, are particularly valuable. They are given in detail with tables of results.

"The Hawaiian Islands" is the title of a little pamphlet just issued by the passenger department of the Chicago & North Western Railway. The advantages and characteristics of the islands with regard to business opportunities are set forth, and so much interesting information is given as to make it worth while to write for a copy. The last few pages are devoted to showing that the best way to get there is over the Chicago & North-western line, as a part of the Chicago, Union Pacific & North-western line. The pamphlet is well printed, and is unique and attractive.

The Safety Appliance Co., Ltd., of Boston, has issued an illustrated, standard size 20-page pamphlet for the purpose of giving information in regard to the appliances manufactured and sold by them. The purpose of these is to advance economical operation of cars and locomotives. Among them are the following: The brake equalizer, which raises brake shoes when a car is loaded and permits of adjustment of brake beams; the drawbar adjuster, which is intended to automatically adjust the height of drawbars to keep them within the limit required by law; the locomotive spring suspension, which discards the equalizer and substitutes a series of leaf and spiral springs, the spirals being coupled to the ends of the leaf driving springs; the dead lever take up, which is a brake slack adjuster for passenger and freight cars and tender trucks, the device being non-automatic and is operated by the inspectors as they examine the condition of the trucks in a train. The appliances are patented in the United States, Canada, Great Britain and France. The address of the Safety Appliance Company is the Wentworth Building, Boston, Mass.

The Weir Frog Company has issued a new catalogue, No. 5, which is similar in appearance to the earlier editions, but has 50 additional pages and 72 new engravings. A number of new devices are shown in addition to the usual product of the works. These are improved spring frogs, on pages 63 to 67; new combination crossings, on pages 109 and 127. A new design of three-throw split switch, with reinforced switch points and adjustable rods, is shown on page 157. The derailing safety switches for sidings are found on pages 170 to 175, and a new form of derailing switch for electric roads is illustrated on page 177. This is a very important device for the protection of crossings between steam and electric roads, and it should be brought to the attention of all officers who are concerned with the safety of these most dangerous of all crossings. A footguard for frogs, switches and guard rails is shown on page 244, and four pages are devoted to railroads for industrial works. A complete illustrated description of the electrical interlocking system under the patents of Messrs. F. C. Weir, Jos. Ramsey and others is given on pages 276 and 297. The catalogue closes with tables and data useful in connection with track and switch work.

The Egan Company, Cincinnati, Ohio, have just issued a handsome souvenir. This concern makes a complete line of wood-working machinery. It is handsomely designed and is printed in two colors, red and blue, and being on fine white paper, makes a patriotic combination of colors. This poster shows about one hundred of their latest improved machines, especially adapted to planing mills, carpenter, sash, door and blind work, furniture, chair and bracket factories, car, railway, bridge and agricultural works, buggy, carriage and wagon builders, spoke, wheel and handle factories, colleges, technical schools, state institutions, navy yards, etc., and every user of machinery should have one of these hung up in his office for reference. This company, which is the largest wood-working machinery concern in the world, have had a special corps of expert mechanics and draughtsmen at work for the past year or eighteen months, whose sole duties have been to design machines on advanced principles and improve those already built. The line of machinery they now have to offer is stated to be superior to any other on the market, and they can furnish either single machines or complete equipment for doing any kind of work in wood. A copy of the souvenir will be sent upon application.

EQUIPMENT AND MANUFACTURING NOTES.

Machines for dovetailing lumber for packing cases are reported to be needed in Nantes, Brest, Lorient, and Concarneau in France. Consul Brittain advises Americans to correspond with Mr. Edward Kerr, 3 Rue Gresset, Nantes.

The Johnson hopper bottom and door and the McCord journal box and lid were specified for the new cars for the Delaware & Hudson, which are being built by the Buffalo Car Manufacturing Co. The Johnson hopper door was illustrated in our issue of August, 1898, page 276.

The Carnegie Steel Co. is reported to be about to erect a new gun plant on a plot of ground on the Monongahela, near the armor plate mill. Four buildings will be equipped with lathes and other machinery. The addition will require 2,000 more hands.

Messrs. William R. Trigg and J. J. Montague, of the Richmond Locomotive Works, are to establish a shipbuilding company and a permanent plant at Richmond for the construction of present contracts with the Government and for further shipbuilding work. The capital is \$300,000,000, and Mr. Trigg is to be manager.

The Chicago Pneumatic Tool Company has found it necessary to open an office in the far West. The President of the Company, Mr. John W. Duntley, has just returned from an extended trip to the Pacific Coast and found so great a demand for the pneumatic tools as to require a branch office, which has been located at 537 Mission street, San Francisco, under the charge of Mr. Henry Englas.

The Schoen Pressed Steel Company of Pittsburgh receives so many inquiries concerning steel cars from all parts of the world and there are so many orders in hand as to lead authorities on the subject of iron and steel to predict that this industry will take a very high place among those using steel. The present capacity of the Schoen shops is 150 cars per week, and orders are now on the books to keep them busy for some time.

Boyer pneumatic hammers by the Chicago Pneumatic Tool Company are being used in constructing a new floor system and generally strengthening a 265 ft. span of the Illinois Central bridge at West Point, Kentucky. Compressed air is furnished by a 12 H. P. gasoline engine direct connected to an air compressor and placed on the bridge. The hammers are driving $\frac{3}{4}$ and $\frac{7}{8}$ -in. rivets and each does the work of four men by the hand method.

An engine shaft weighing 63,000 pounds, 27 feet 10 inches long, with a maximum diameter of 37 inches, is being made by the Bethlehem Iron Co. for the Corliss Steam Engine Co. The diameter at the bearings is 34 inches, and at the crank disc fit 32 inches. It is hollow, the hole being 17 $\frac{1}{2}$ inches diameter. The specifications call for an elastic limit of not less than 50,000 pounds per square inch, and an elongation of 18 per cent. in a test bar one inch in diameter and 10 inches long.

Comparisons of the merits of several different metallic trucks are to be made on the Chesapeake & Ohio. The plan is to build 100 coke cars of 30 tons capacity at the shops of the road and equip them with five or six different steel trucks. The cars will all be in the same service and the examination for condition under service will allow sufficient time to bring out the relative values of the designs. It is also understood that the makers will be allowed to furnish the best trucks that they can build.

A new window and car sash lock has been invented and perfected by Mr. J. Wilson Wright, 73 Vesey street, New York. It employs a rotating gear, which engages in a rack at the side of the window. This gear is within the lock, and is held at any desired position by two pawls, which are released by finger levers. The advantages stated are that the window may be held at any desired height, or it may be held closed without danger of being either raised or lowered from the outside, and the window cannot fall when held open.

Mr. George H. Campbell, Terminal Agent of the Baltimore & Ohio Railroad at Baltimore, has, in addition to his present duties, been appointed Inspector of Stations and Terminals over the whole line, reporting to the General Superintendents in their respective territories. Mr. Campbell has long been known for his ability in this direction and the object of the appointment is to secure at each terminal better service in every respect, and is in line with the policy of the Receivers to give to the patrons of the road better and quicker facilities for the handling of freight.

Negotiations have been completed for the consolidation of the Union Switch & Signal Company of Pittsburgh and the National Switch & Signal Company of Easton, Pa., and a meeting of the stockholders of the Union Switch & Signal Company has been called for Dec. 13 next to ratify the purchase of the capital stock of the National Company. At the same time a vote will be taken on a proposed issue of gold bonds amounting to \$500,000 and bearing 5 per cent. The result of the consolidation will be that the switch and signal business of the country will be controlled in Pittsburgh.

The Baltimore & Ohio Southwestern Railroad has just received from the Baldwin Locomotive Works 10 new freight locomotives, eight simple and two compound, for use on the Ohio division, from Cincinnati to Parkersburg. This portion of the road has some rather heavy grades, and these are the first heavy engines to be used on the line. They are expected to increase the train haul about 40 per cent. The simple locomotives have 21-in. x 28-in. cylinders and the compound 15 $\frac{1}{2}$ and 26-in. x 28-in. cylinders. The locomotives were built from designs furnished by Mr. J. G. Neuffer, Superintendent of Motive Power.

The Chicago, Burlington & Quincy is having 600 gondola coal cars of 80,000 pounds capacity built in lots of 300 each, by the Wells & French Co. and the Michigan Peninsular Car Co., for delivery before Jan. 1. The inside length is 35 feet 10 inches; the inside width 9 feet 1 inch; the length from top of sides to rail, 7 feet 3 $\frac{3}{4}$ inches; the frame, flooring and sides are of wood, and the body bolsters, the brake beams, brasses and draft rigging are the C., B. & Q. standards. The brake shoes are the "Congdon," the brakes, Westinghouse, and the couplers "Chicago." All the castings are of malleable iron. The trucks have the C., B. & Q. standard drivers and frames, and the light weight of the car is 28,400 pounds.

The Baltimore & Ohio Railroad is experimenting with an 80,000-pound coal car between Cumberland and Baltimore, where the heavy movement of coal will justify an increase in the capacity of the cars. The present cars now in use have 50 per cent. greater capacity than those used three years ago, but with the changes in the line and the relaying of the track with 85-pound steel, and the erection of modern steel bridges, the receivers believe it possible to increase the car capacity to 80,000 pounds. Plans are also being made at the Mount Clare shops for a locomotive to weigh between 225,000 and 230,000 pounds, the cylinders to be 23 by 30 inches, and the rest of the engine in proportion. If this engine is built it will be used on the heavy grades between Cumberland and Grafton.

The method of sheathing passenger cars with sheet copper, devised and patented by Mr. W. P. Appleyard, Master Car Builder of the New York, New Haven & Hartford R. R., is meeting with substantial indorsement from a number of roads. The Fitchburg, Erie and Southern Pacific and the Pullman Company have taken it up and the reports are full of high praise. In the far West the relief which it gives from the effects of alkali dust, that is very destructive to varnish, is a strong recommendation. The appearance of the copper sheathed cars that were exhibited at Saratoga last summer was handsome, and Mr. Appleyard tells us that the coating will not require attention or renewal, and that after the experience of coating the first car it may be applied cheaper than paint and varnish.

The condition of the car building industry, as reflected by the annual report of the Michigan Peninsular Car Company, is good. The statement of earnings for the year ended August 31, 1898, showed a total of \$679,877.12. Four dividends, amounting to \$300,000, were paid. The sum of \$100,000 was paid on the \$2,000,000 of first mortgage bonds, leaving surplus earnings for the company's sixth fiscal year at the sum of \$270,877.12, the best record, with one exception, in its history. The grand total of earnings is \$2,306,063.62; disbursements, dividend and interest account, \$1,710,000, and operating expenses, \$87,539.42, leaving a balance of \$508,524.20; material and surplus on hand, valued at \$1,554,289.02; cash, \$219,878.44; bills receivable, \$429,870.70; amounts due from sundry corporations and firms, \$376,175.34; audited vouchers for material not yet due, \$679,978.77.

The following Baltimore & Ohio rumors are not substantiated at the headquarters of the company: That the B. & O. is contemplating shortening its main line from West Union, W. Va., to the Ohio River by building a new track down the valley of Middle Island Creek to the Ohio River near Marietta; that the B. & O. is about to invade the territory of the Pennsylvania South Western branch and that a road will be built from some point near Connellsville which will reach the coal deposits between the Youghiogheny River and the Pennsylvania Railroad; that the B. & O. is to build a million-dollar tunnel under Mt. Alry, Md., in order to eliminate a heavy grade. The only foundation for this rumor is the fact that re-

cently there has been some talk as to what could be done toward improving that portion of the line, but no action whatever has been taken.

Mr. M. Cokeley, who is probably known to many of our readers, has been made Superintendent of the works of the C. W. Hunt Co., Staten Island, N. Y., having assumed the duties of that position Oct. 14, after several months' work revising the factory systems. Large concerns are beginning to relieve the office management of the providing for the details in office routine, the installation of systems, methods, etc. This work properly belongs to a specialist, one who, constantly keeping his eyes open for improvement, studying the best literature on the subject and devoting his energy entirely to this work, becomes an expert. Mr. Cokeley has made this special work his profession for some time, being for many years with the General Electric Company and later with other prominent firms. His experience as a practical mechanic has been of great benefit to this line of work, enabling him to detect almost instantly the leaks that invariably exist, and which are so destructive to profits.

The Q & C Co. inform us that they have absorbed the Dustless Roadbed Company, of Philadelphia, and the use of oil for the prevention of dust on railroads will be actively pushed by the purchasers. The sprinkling of roadbeds with oil is operated under the Nichol and Mattern patents. It has already been tried by a number of roads with very satisfactory results. The Pennsylvania, the Long Island and the Boston & Albany roads have each treated 100 miles of their track, and the Boston & Albany has the application for its entire line in contemplation. The New York, Philadelphia & Norfolk reports exceedingly satisfactory results, and applications for short distances of about 10 miles have been made on the Fitchburg, New York, New Haven & Hartford, and Chicago & West Michigan railroads. We believe that the latter road has more than this. The Wisconsin Central is now trying it, and a number of other lines have signified their intention of doing so. On the roads first mentioned it is found that three applications the first year are sufficient, and after that it is required less often.

The divisions of the Baltimore & Ohio Railroad west of the Ohio River are to receive the same sort of improvements that have been made on the lines east of the Ohio. Not only are the grades to be reduced wherever it is practicable, but very much heavier motive power is to be introduced. In order to carry the additional weight the bridges on all the divisions are being replaced with heavier structures and the track relaid with heavier rail. It has been demonstrated by actual experiment that these changes will result in an increase in train loading in some places of more than 50 per cent., the average being about 42 per cent. It is the hope of the receivers that within the next two years the Baltimore & Ohio Railroad will be an 18-foot grade road from Chicago to Baltimore with the exception of that portion of it which passes over the mountains, where helping engines must be used. Many of the estimates for the different portions of the work have been made, and those who have seen the plans state that the work can be done at a surprisingly low cost considering the return. It is understood that the policy of rehabilitation adopted by the receivers two years ago will be continued by the new company after the reorganization.

In a recent letter to the Westinghouse Electric and Manufacturing Company, Mr. R. G. Vance, Jr., Superintendent of the Stevens Coal Company, makes the following statements regarding the Baldwin-Westinghouse electric mine locomotive in operation in their mines, and illustrated on page 263 of our August, 1898, issue: "It gives us pleasure to say that this motor is giving the very highest possible satisfaction, and is attracting considerable attention in this valley. It has been running since May 1 and has not cost a dollar in the shape of repairs, excepting a new valve for the sand box and a headlight base broken in a collision with a car. It is running on a road of 25-pound steel rail, 4,000 feet long, over undulating grades varying from 1 to 6 feet per 100 feet. Its regular load now consists of 20 cars of 1½ tons' capacity, and the time required for each round trip is from 17 to 19 minutes. We have pulled as many as 25 of these cars at one trip, which is done with ease. When necessity

requires we can pull 30 cars, giving 50 per cent. more capacity than you guaranteed." This is evidence of the qualities of this mining locomotive, which is characteristic of the work done by the Baldwin and Westinghouse companies.

OUR DIRECTORY

OF OFFICIAL CHANGES IN OCTOBER.

Columbus, Sandusky & Hocking.—Mr. George H. Kimball has been appointed Superintendent and Chief Engineer, with headquarters at Columbus, Ohio, to succeed Mr. M. F. Bonzano, resigned. Mr. Kimball was formerly Superintendent of the Eastern Division of the New York, Chicago & St. Louis. Mr. B. S. Snyder has been appointed Master Mechanic, with headquarters at Columbus, Ohio, in place of Mr. T. M. Downing, resigned.

Chattanooga Southern.—Mr. M. F. Bonzano has been appointed General Manager, a position which he held before going to the Columbus, Sandusky & Hocking. He succeeds Mr. M. S. Hoskins.

Detroit & Lima Northern.—Mr. Jules S. Bache, New York, and Mr. James B. Townsend, Lima, O., have been appointed Receivers of this road. Mr. C. H. Roser, Chief Engineer, has also been appointed Purchasing Agent, vice Mr. C. W. Taylor.

Erie.—Mr. J. W. Patten has been appointed Assistant Purchasing Agent, with headquarters at New York.

Houston & Texas Central.—Mr. F. B. Goodrich has been appointed Assistant Engineer, with headquarters at Houston, Tex.

International & Great Northern.—Mr. J. D. Trammell has been appointed Chief Engineer, with headquarters at Palestine, Tex. He was formerly Resident Engineer.

Kelly's Creek.—Mr. J. W. Dawson has retired from the office of Superintendent of the Kanawha & Michigan Railway to accept the position of General Manager of the Kelly's Creek Railroad, with office at Mammoth, W. Va.

Lowell & Hastings.—Mr. Wm. H. Clark has been appointed General Manager, in addition to his duties as Traffic Manager. His headquarters will be at Lowell, Mich.

Lehigh Valley.—Mr. F. W. Gilcreast has been appointed Division Engineer of the Mahanoy & Hazleton Division of this road, with office at Hazleton, Pa.

Mississippi Valley.—Mr. Robt. Carrlitt has been appointed Chief Engineer, with headquarters at St. Louis, Mo.

Northern Pacific.—Mr. Alfred Lovell has been appointed Assistant Superintendent of Motive Power, with office at St. Paul, Minn.

Norfolk, Virginia Beach & Southern.—Mr. W. T. McCullough has been appointed General Manager, with headquarters at Norfolk, Va.

Pittsburg, Cincinnati, Chicago & St. Louis.—Mr. Robert C. Bernard has been promoted to the position of Engineer Maintenance of Way.

St. Louis, Iowa & Northern.—Mr. C. J. DuBois has been appointed Chief Engineer and Superintendent, with headquarters at Macon, Ga.

Sylvania.—Mr. L. H. Hilton, President and General Manager, and Mr. G. M. Hill, Treasurer, with headquarters at Sylvania, Ga., have resigned. Mr. P. D. Daffin has been elected President and Treasurer, with headquarters at Savannah, Ga.

Tennessee Northern.—Mr. A. A. Glasier has been elected President, succeeding Mr. H. M. La Follette, who has been elected Vice-President. Mr. Glasier's headquarters are at Boston, Mass.

Utah & Pacific.—Mr. Jos. A. West has been appointed Chief Engineer. He was formerly General Freight and Passenger Agent of the Sumpter Valley Railway of Oregon.

Western Maryland.—Mr. H. E. Passmore has been appointed Master Mechanic, with headquarters at Hagerstown, Md. Mr. David Holtz has been heretofore Master Mechanic, with headquarters at Union Bridge. Mr. Passmore has been Foreman of the Philadelphia & Reading shops at Tamaqua.

West Virginia, Central & Pittsburgh.—Mr. J. S. Chambers has accepted the position of Superintendent of Motive Power, with headquarters at Elkins, W. Va., to succeed Mr. J. S. Turner, resigned.

LICENSES

To be sold in each district for Patent Safety Apparatus for Gauge Glasses adaptable for any kind of steam boiler. United States Patent No. 409,280. Greatest success in Europe under Government control and legalized introduction. First-class technical firms only are invited to correspond with HERREN: LEYMANNS & KRIM, Aix La Chapelle, Germany.

AMERICAN ENGINEER CAR BUILDER AND RAILROAD JOURNAL.

DECEMBER, 1898.

CONTENTS.

ILLUSTRATED ARTICLES:	Page	MISCELLANEOUS ARTICLES:	Page
Short Smoke Boxes for Locomotives.....	391	Locomotive Improvements, N. P. Ry.....	400
Susemihl-Torrey Side Bearing.....	394	U. S. Repair Ship Vulcan.....	401
Pusher Locomotive, Lehigh Valley R. R.....	395	Great Areas and Heating Surfaces.....	402
Locomotive Design, Springs.....	396	Dangerous Locomotive Cabs.....	402
Narrow Gauge Locomotive.....	398	Pneumatic Riveting with Portable Machines.....	406
Circular Headlight, C. M. & St. P. Ry.....	400	Water Tube Boilers, U. S. Navy.....	407
Starting Valve Locking Device for Compound Locomotives.....	403	Tao Air Brake Situation.....	408
Harris Direct Air Pressure Pump.....	407	Breakage of M. C. B. Couplers, Pennsylvania Station, Jersey City.....	408
Pneumatic Chain Hoist.....	408	New York Railroad Club.....	411
Chemistry Applied to Railroads.....	409	The Track Tank.....	412
Coates' Portable Emergency Crossover.....	411	Books and Pamphlets.....	413
Improvement in Flooring Machines.....	412	Electric Motors in Railroad Shops.....	416
Hornish Boiler Cleaner.....	413	Cupped Firebox Sheets.....	417
Shop Sawing Machines.....	415	Lead and Zinc Paints.....	417
Continuous Rivet Furnace.....	416	Personals.....	418
A New Coupler Gauge.....	416	EDITORIALS:	
MISCELLANEOUS ARTICLES:		Directory of Railroad Officials.....	404
Locomotive Cylinder Proportions.....	389	Management of Engineering Matters.....	404
All Work for Nothing.....	395	Breakage of Piston Rods.....	404
		Increased Piston Stroke.....	404
		Present Status of Compound Locomotive.....	405

LOCOMOTIVE CYLINDER PROPORTIONS.

By G. R. Henderson,
Mechanical Engineer, Norfolk & Western Railway.

In these days of railroad economies, where trains of such weight are hauled that, in the language of a prominent superintendent, "the engine would have stalled had a fly alighted on the train," and when trainmen will soon be instructed to "get off and push" over summits, it is of the utmost importance in designing a locomotive to take advantage of every pound allowable, in order to obtain the maximum tractive power possible under the given conditions. In order to realize this the coefficient of adhesion must be reached, but this is somewhat uncertain, its value, however, being generally fixed between 20 and 25 per cent., 22 per cent. probably indicating the ordinary friction between the wheels and the rails.

A committee of the Master Mechanics' Association in 1887 recommended a cylinder proportion which, at a mean effective pressure of 86 per cent. of boiler pressure, gave a coefficient of adhesion of 22 per cent. The value "86 per cent." hardly allows for the internal friction of the engine, which, if taken at 8 per cent., will give a "mean available pressure" of 80 per cent. of the boiler pressure. This would allow for a coefficient of adhesion of about 21 per cent. Improved sanding apparatus will, however, permit a value of 25 per cent. being reached, and perhaps more, but just how much is not definitely known. This evidently varies with the external conditions, as in some recent tests it was found necessary to use sand on curves when the net tractive power was only about 21 per cent. of the adhesive weight. The general tendency, at this time, is not to exceed 25 per cent. Angularity of the connecting rod in connection with the variation of steam pressure during the stroke, will increase the tendency to slip at certain angles of the cranks by from 10 to 15 per cent., but this may ordinarily be neglected.

In order to make comparisons more readily we can use the formula for the ratio of theoretical tractive power to adhesive weight:

$$R = \frac{P \cdot d^2 \cdot s}{D \cdot W}$$

Where P=Boiler Pressure.
d=Diameter of Cylinder.
s=Stroke of Piston.
D=Diameter of Drivers.
W=Adhesive Weight, all expressed in pounds and inches.

In this case a ratio of 0.31 corresponds with 25 per cent. actual available power, allowing for drop in pressure, expansion and internal friction, as explained above.

Two years ago the writer, in connection with some committee work, collected a large amount of data concerning engines of different types in various parts of the United States and Europe. While in passenger locomotives the values of R varied between .22 and .34 as limits, the average value was .26, but one engine having a greater ratio than .30. The freight engines had .21 and .31 as limits, there being two with the latter value, the average being, however, .27. These figures refer to engines operated in the United States.

In European practice we find greater discrepancies; thus the passenger engines varied from .22 to .42 (the latter in Belgium), with an average of .28, while in freight service the ratios ran from .15 to .34, the average being .25. As above stated, these figures were collected about two years ago. Let us now see how these figures have been modified in the last year or two, in order to determine the general tendency on this point.

On page 296 of the September number of the "American Engineer" a table of recent heavy locomotives was given, and we will examine these, with the Chicago Great Western Mogul and the Great Northern 10-wheel passenger engine, comparing at first the simple engines only:

COMPARISON OF HEAVY LOCOMOTIVES.

Railroad.	Builder.	Type.	Steam.	Cyl.	Wh'l.	Adhes. Wgt.	"R"
Mch. Central.	Brooks.	—	180	21x26	49	145,000	.29
B. & O.....	Pittsburgh.	Consol.	180	22x28	54	152,800	.294
D. M. & N.....	"	"	160	22x28	50	144,000	.30
Bu. & Susq..	Baldwin.	"	480	22x26	51	147,300	.31
D. & I.....	Schenectady	—	180	22x26	51	139,000	.30
Penna. (H-5)..	P. R. R.	Consol.	485	23x28	56	186,000	.274
B. & M.....	Pittsburgh.	"	180	22x28	52	166,000	.28
Gt. Northern.	Brooks.	Mastodon.	210	21x31	55	172,000	.324
"	"	10-Wheel.	210	20x30	63	129,500	.314
C. G. W.....	Richmond.	Mogul.	200	19x28	60	100,000	.33

It will be seen at once that there is a marked tendency to increase the ratio of tractive power to adhesive weight. There is no doubt that, as above mentioned, pneumatic sanders have been largely the means of permitting this increase, but it is still an open question whether ratios over .30 are desirable in new engines. As the wheels wear down and the cylinders wear large, the value of "R" will grow until, in the case of the C. G. W. mogul, with tires worn 1½ inches in thickness and cylinders bored out 1 inch larger, we have a ratio of nearly .39. Some recent tests with compound engines, in which R had a value of .37 when working simple, made it necessary to sand continually on straight track, while operating as a single expansion locomotive. Besides the great tendency to slip, we should consider the waste of steam and metal in tires and rails when slipping does occur, and we understand that some engines in which the value of "R" exceeds .30 are both slippery and heavy on fuel.

The value of "R" in compound locomotives of the two-cylinder type shows very great ranges. In order to be able to make a comparison with the figures just given for simple locomotives, let us substitute in our formula for "P," the value

$$\frac{\text{Boiler Pressure}}{\text{Cylinder Ratio} + 1} \text{ and the}$$

diameter of low pressure cylinder for "d," when working compound, and let "P"=boiler pressure and "d"=diameter of high pressure cylinder, when working as a simple engine.

If we calculate the values of "Rc" and "Rs" (the ratio of theoretical tractive power to adhesive weight when working compound and simple respectively) we have for the C. G. W. compound mogul of the Richmond Locomotive Works, and the

Northern Pacific mastodon of the Schenectady Locomotive Works as follows:

Railroad.	Type	Steam.	Cylinders.	Wh'l.	Ad. W't.	Rc.	Rs.
No. Pacific.	Mastodon.	200	23 & 34 × 30	55	150,000	.26	.38½
C. G. W....	Mogul....	200	21 & 33 × 28	60	100,000	.29	.41

The C. G. W. mogul is identical with the last engine in the former table, except in the matter of cylinders. We see from this that the two-cylinder compound locomotive as built will have "Rc" smaller and "Rs" greater than the same weight of simple engine. This is not always a disadvantage, nor on the contrary, is it in all cases a desired property. If the average grades are easy, and the simple operation is needed only for starting or passing short but heavy slopes, the combination obtained in this class of engine is perfectly logical, and the locomotive can be loaded satisfactorily to work compound during almost the entire trip. But should the engine be destined to work entirely on heavy grades, where the utilization of the total adhesion is of more value than the saving of 15 or 20 per cent. of fuel, and when the lever is kept constantly in the "corner," it will at once be evident that the advantage is with the simple engine, because to haul the same load the two cylinder compound would have to be operated in single expansion.

When the question of speed is considered, however, the compound (when worked as such) has the advantage, as a longer distance can be traveled with the same steam consumption, or what is the same thing, for a given boiler capacity (and weight) a higher average speed can be maintained. In some recent investigations it was calculated that a compound locomotive of the same adhesive weight as a simple engine, and with boiler 2 inches smaller at the front end, in order to allow for the extra weight of compound cylinders, would furnish steam for a speed of 15 per cent. greater than the simple engine, the compound cylinders being proportioned to give the same tractive effort as the simple cylinders. This is a point well worth considering, in designing and operating locomotives.

It must not be inferred from our remarks above that we are opposed to large cylinders; on the contrary, we have always advocated them of greater volume than most master mechanics have been willing to admit as the proper proportion, but at the same time different conditions require different treatment. For high speed passenger engines, where the large majority of work is done at an expansive ratio of 3, 4 or 5, we strongly favor cylinders that would easily slip the wheels if worked full stroke with a fair throttle opening, as this is undoubtedly the only way in which you can haul the heavy trains at a high speed. It is true that under such conditions there will be certain points or periods during each revolution where the pressure will be great enough to overcome the adhesion. Thus, at $\frac{1}{2}$ cut off the maximum rotative force is 50 per cent. greater, and at $\frac{3}{4}$ cut off, 30 per cent. greater than the average rotative force during a whole revolution. But if the engine is running at a high speed, the inertia of the drivers, acting as flywheels, will probably be sufficient to resist the momentary application of this maximum force.

The same arguments do not apply, however, to freight engines as a general thing. The speed is ordinarily low—60 revolutions or so a minute—and if an attempt is made to operate with an early cut-off and a high average pressure, the maximum rotative forces, above referred to, would be almost sure to cause slipping at certain parts of the revolution. When at high speeds the inertia of the reciprocating parts tends to neutralize a high steam pressure at the commencement of the stroke, and to assist the low expanded pressure at the end of the stroke, so that the pressure is maintained more nearly constant on the crank, due to this fact, but at slow speeds the benefits of inertia are not apparent. Railroad managers uniformly insist upon an engine in freight service hauling every pound of which it is possibly capable, even though this be greater than the load for which it was designed. These various points indicate that the conditions under which

freight engines ordinarily operate are not conducive to the use of large (relatively) cylinders and high expansive ratios. This is probably one reason that two cylinder compounds are rather more common in freight than in passenger service.

Along with the increasing size of cylinder has also come the long stroke. For years 24 inches was considered as a standard stroke for locomotives in this country, but now 26 and 28 inch strokes are common and 30, 32 and 34-inch strokes are making their appearance. There are several reasons why we have this increase in stroke. A very important one is that the clearances on many roads would not permit a cylinder of suitable diameter to give the necessary tractive force, to pass without striking, particularly in the case of the low pressure cylinders of 32 and 35 inches in diameter. Larger driving wheels have the advantage of keeping the large cylinders further from low obstructions, but this also necessitates larger cylinders. Then, again, some claim that with a large wheel and short stroke the distance through which the engine travels while the crank describes the portion of its revolution near the dead centre, when no rotative force from the piston reaches it effectively, is so great as to interfere seriously with its operation at slow speeds. The fact that pistons, rods and crossheads, as well as main rods and crank pins, can be made lighter, is also an argument in favor of long strokes, though the higher speed of reciprocating parts thereby made necessary certainly largely offsets the last claim. A long stroke on a comparatively small wheel brings the crank pin very near the rim, and the rods very close to the dirt of the track. The centrifugal force on the rods, tending to bend them in a vertical plane, is increased in proportion to the length of stroke.

If we wish to make a cylinder with the least amount of radiating surface for a given volume, the length should be equal to the diameter. Considering this property alone, we should not increase the stroke until the diameter reached the old standard value of 24 inches. Now as we have low pressure cylinders up to 35 inches in diameter, good proportions for a minimum amount of surface would require a longer stroke. This, and the fact that the side clearance is limited, will probably account for the gradual introduction of long strokes, but on general principles we think that the stroke should be kept down to from 1 to $1\frac{1}{4}$ times the diameter, unless it is impracticable to obtain the necessary clearance.

Our comparisons between cylinder power and weight have been made with the adhesive weights only, but the total weight is a matter of considerable importance. The weight of a locomotive, as a whole, is, or should be, primarily dependent upon the boiler and its contents, and correct designing requires all the parts of machinery and carriage to be as light as is consistent with strength—the boiler and its contents are alone intended to be heavy. Now the weight on drivers limits the load which can be drawn, but the boiler proportions limit the speed at which it can be operated when hauling the maximum load. If the boiler is small, we can haul as heavy a weight (provided, for the sake of argument, that the adhesive weight remains constant) as we can if the boiler be large, but the speed will be unsatisfactory. Now to increase the size and weight of the boiler without increasing the load on drivers (which may have reached its limit already, and probably has in the opinion of the Maintenance of Way Department) we must arrange for the increase to be carried on trucks. A two-wheel, or pony truck, carries, ordinarily, from 15,000 to 20,000 pounds, whereas a four-wheel truck can easily be loaded with double that amount. If now we consider the case of a mogul or consolidation engine, in which it was desired to increase the speed or work done, without placing any more weight on the drivers, we should have to take recourse to the 10-wheel, or mastodon type. Let us see what we should gain and lose by such a change. Suppose that we have had a consolidation locomotive with 150,000 lbs. on drivers and 20,000 lbs. on the truck; the boiler is 64 inches in diameter at the first barrel ring, and there are 263 tubes with $2\frac{1}{4}$ inches

outside diameter, the total heating surface being about 2,400 square feet.

If we redesign this engine, and substitute a four-wheel truck for the pony, we can increase the total weight of the engine 20,000 lbs. The new arrangement of truck will enable us to place our cylinders about 3 feet farther ahead of the driving wheels. This extra 3 feet in the length of boiler will give us 465 square feet more heating surface, or about 20 per cent. increase. The extra weight of this much boiler added will amount to about as follows, per foot of length:

Boiler 64 inches diameter.		Boiler 68 inches diameter.	
	Lbs.		Lbs.
Tubes (263-2/4 inches).....	647	Tubes (306-2/4 inches).....	753
Shell	480	Shell	560
Water	730	Water	825
Total	1857	Total.....	2138
	or 83 lbs. per cubic foot.		or 85 lbs. per cubic foot.

These figures consider the water as standing 4 inches above the highest part of the crown sheet, and the sheets are strong enough to carry 200 lbs. pressure per square inch. No allowance has been made for lagging or jacket.

The 3 feet in length of boiler will therefore increase the weight about 5,600 lbs., the extra length of frames about 900 lbs., and the four-wheel truck over the pony about 4,000 lbs., or a total increase of about 10,500 lbs. As we are allowed 20,000 lbs. increase by the substitution of the four-wheel truck, and have used but 10,500 lbs., so far, we can increase the size of the boiler by nearly 4 inches and this will give us 400 square feet more of heating surface, or a total increase of 865 square feet, or 36 per cent., with an increase in dead weight of 12 per cent. In addition to 36 per cent. (or thereabouts) increase in available steam capacity, we have the greater economy in fuel, owing to the reduced rate of combustion per square foot of heating surface, and from this we would expect a possible speed of 14 miles per hour against 10 miles with the first engine. The extra weight of the engine would diminish the actual train load by 10 tons, but this is a small price to pay for the gain in speed.

If the engines under consideration were not loaded to their maximum adhesion, of course the extra steaming qualities would be an advantage for loads, as well as speeds. The application of just such considerations as we have outlined has been tersely expressed by a well known chief engineer of a Rocky Mountain road: "Experiment showed our engines to be very deficient in steaming power in all cases where they were called upon to overcome high resistance, at speeds over 12 or 15 miles per hour, and . . . the length of train is determined by the ability of the engine to develop horse power, and is almost independent of the weight on the drivers. . . . To sum up, the weight on drivers should be proportioned to the maximum rates of grades, while the steam making capacity should be proportioned to the average resistance and schedule speed, as an engine of given weight on drivers, designed to develop a given horse power, would utilize its full adhesion, under favorable conditions, while under other conditions it would utterly fail to develop sufficient horse power to utilize even 50 per cent. of the adhesion due to weight on drivers. We, therefore, expect to provide engines of greater horse power for the same weight on drivers."

SHORT SMOKE BOXES FOR LOCOMOTIVES.

The design of locomotive smoke boxes is being considered carefully, and the present tendency is toward reducing their length, and instead of considering them as receptacles for sparks every effort is being made to render them self-cleaning, while of course the prevention of spark throwing is always in mind. Mr. J. Snowden Bell deserves a great deal of credit for this condition of affairs—for his efforts show that the long extension front was unnecessary and undesirable.

The advantages of short fronts may be stated as: First, the saving of weight; second, the saving of the cost of cleaning out the cinders; third, the improvement in steaming. The

original idea of the extension was to get large areas for the netting, but this may be obtained as well with a short as a long extension. In the report on Exhaust Nozzles and Steam Passages before the Master Mechanics' Association in 1894 (page 112) it was stated that "an increase in the length of the smoke box over and above that necessary to get in a cinder pocket in front of the cylinder is unnecessary and undesirable, as the long smoke box greatly decreases the vacuum. Sufficient area of netting can be put into a smoke box which is long enough to give room for a cinder pocket in front of the cylinder saddle." Mr. Bell had already gone beyond this point, and did not see the necessity for the pocket at all. We show several designs in the accompanying engravings which may be considered as typical examples.

The Norfolk & Western arrangement, as submitted to the Master Mechanics' Association, while retaining the extension, has an important feature, in the line of self cleaning, in the location of the diaphragm and the use of the low nozzle. The idea is to obtain so even a draft on the flues as to avoid pulling the cinders into the front end. The diaphragm is brought down back of the steam pipes and then carried horizontally to the front, and the netting is confined entirely to the extension. Two petticoat pipes are used to equalize the draft, and the lower one is carried down very near to the top of the nozzle. This front end cleans itself and does not throw sparks.

It is evident that the extension not only serves no purpose in this design, but also is opposed to its principle, and it probably appears only because the application was made to an engine already fitted with it. If the smoke box is to be cleared, as is the object of the design, there is obviously no reason for providing a receptacle for sparks, and the vertical portion of the deflecting plate could be set back to the line of the smoke box proper, or even closer to the nozzle, and do its work just as it does in the design as shown. There need only be sufficient space on front of it for the passage of the products of combustion, and the two-thirds or more of the length of the extension, which is now unnecessary, could be dispensed with.

The construction used on the Michigan Central Railroad, in which no cinder pocket is employed, and which is reported to be a satisfactory self cleaner, embodies the same general features, i. e., low nozzle and the bottom of the deflecting plate located in front of the nozzle, as the Norfolk & Western, and, like it, presents the incongruity of a long extension, which is unnecessary, either as a cinder receptacle or a space for netting.

Mr. W. P. Coburn, Assistant Master Mechanic of the Chicago, Indianapolis & Louisville, devised the arrangement shown in Fig. 2. It employs a deflector plate extending down in front of the nozzle, and this throws the sparks down to the front corner of the smoke box, and in passing upward they come into contact with projections upon the inside of the front end door and the door casting, grinding them to powder. When they pass to the stack they go through a netting that is nearly vertical. This arrangement makes it possible to reduce the extension to 15 inches. The sparks are extinguished before they go out, and the arrangement has been so satisfactory that it is being applied to all engines on the road. Mr. Coburn informs us that the steaming qualities of the engines are improved, and also a material saving in fuel is effected.

The design shown in Fig. 3 is by Mr. J. S. Turner, Superintendent of Motive Power of the Union Pacific, Denver & Gulf, and formerly Superintendent Motive Power of West Virginia Central & Pittsburgh Ry. This front end is self-cleaning and is moderately short. Mr. Turner, in a letter written while Superintendent of Motive Power of the West Virginia, speaks of his work on short front ends on that road as follows:

"We have not made any special tests to determine the relative efficiency of this device, as compared with the arrangement most commonly used, but from personal observation we find the locomotives steam more freely, and examination

of our performance shows a saving in fuel. The advantages of the short self-cleaning front end are: (1) Reduction in the length of front end and discarding spark hopper. (2) Bottom steam pipe joints and bolts, cylinder saddle strengthening sheet and saddle bolts, and front end ring and door will not burn and warp, as it completely prevents an accumulation of hot sparks or cinders. (3) No delay on the road caused by stopping to clean front end, and no cleaning at terminals, consequently preventing dust and sparks getting in the truck boxes, and blowing over the locomotive and machinery. (4) Prevention of fires to property along the road. (5) Locomotives will steam more freely and show economy in fuel.

"All of the above advantages will reduce expense. This front end is being applied to all new engines, while a modification is used in repair work when the old rings are in good order. Credit must be given Mr. Bell for the shortening up of the extension, but the arrangement of diaphragm plate and netting, as shown in Fig. 2, is the result of the writer's experimenting on the Mexican Central, and also on this road."

It is evident that Mr. Turner should share in the credit for the improvements in front ends that are indicated in present practice.

The front ends, designed by Mr. J. Snowden Bell, of Pitts-

burgh, are shown in Figs. 4 to 6. Fig. 4 is a very short front, applied in 1897 to a 10-wheel engine, with 20 by 24-inch cylinders, on the Baltimore & Ohio. The deflecting plate near the ends of the tubes is punched with lips projecting toward the front from the holes. A sheet of netting prevents cinders that may pass through the deflector plate from going directly into the stack, while the main portions of the netting are in three intersecting planes in front of the nozzle. A small opening is left between the first two nettings in order to allow cinders to drop back into the lower space instead of clogging the angle of the nettings. A sheet of netting below the opening prevents the direct egress of sparks. The deflector plate directs the current of sparks to the front lower portion of the smoke box, where they come into contact with a corrugated plate supported by fire clay. This front end cleans itself, and the engine steams very freely without throwing sparks.

The Great Northern 12-wheel freight engines, illustrated in our January, February and March issues of the current volume, have the Bell arrangement shown in Fig. 5. These

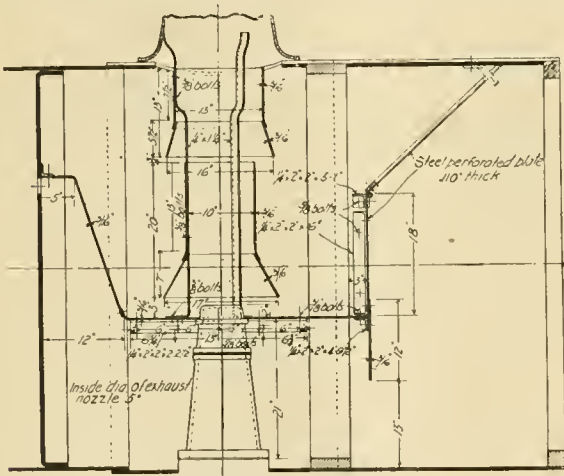

Fig. 1. - Norfolk & Western.

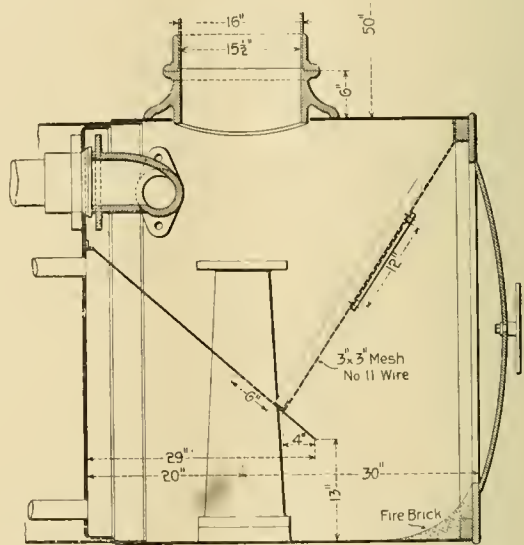

Fig. 3. - West Virginia Central & Pittsburgh.

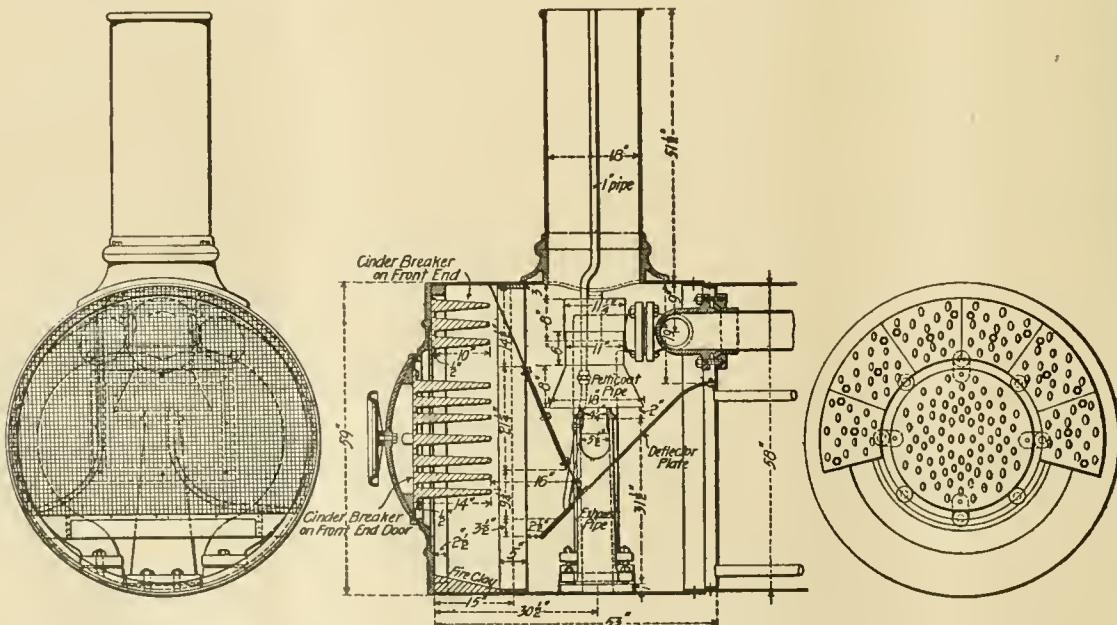

Fig. 2. - Coburn's Arrangement, Chicago, Indianapolis & Louisville.

SHORT SMOKE BOXES FOR LOCOMOTIVES.

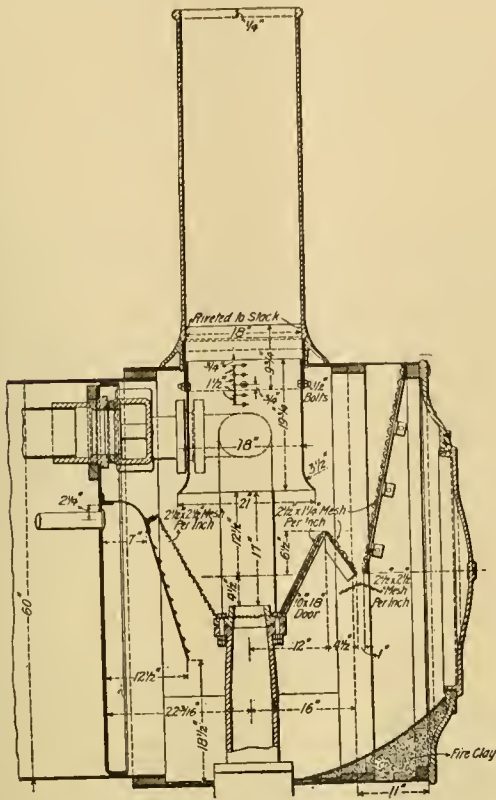

Fig. 4.—Baltimore & Ohio.

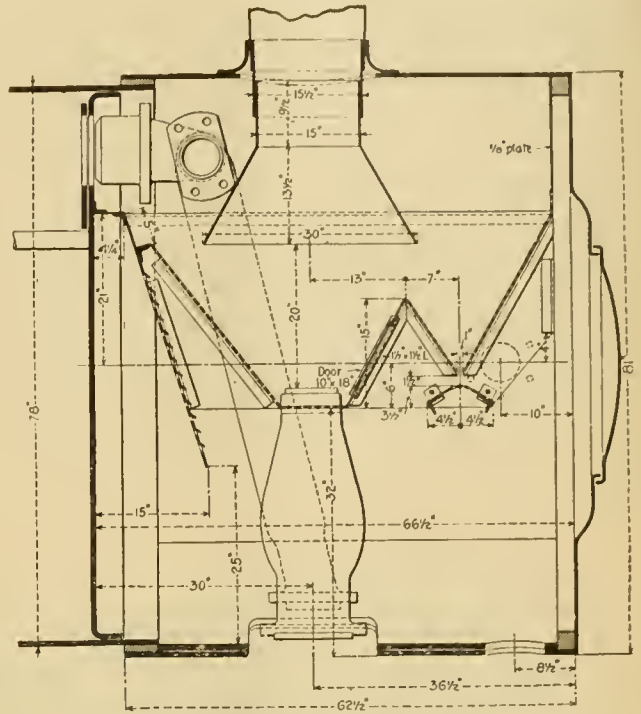

Fig. 5.—Great Northern.

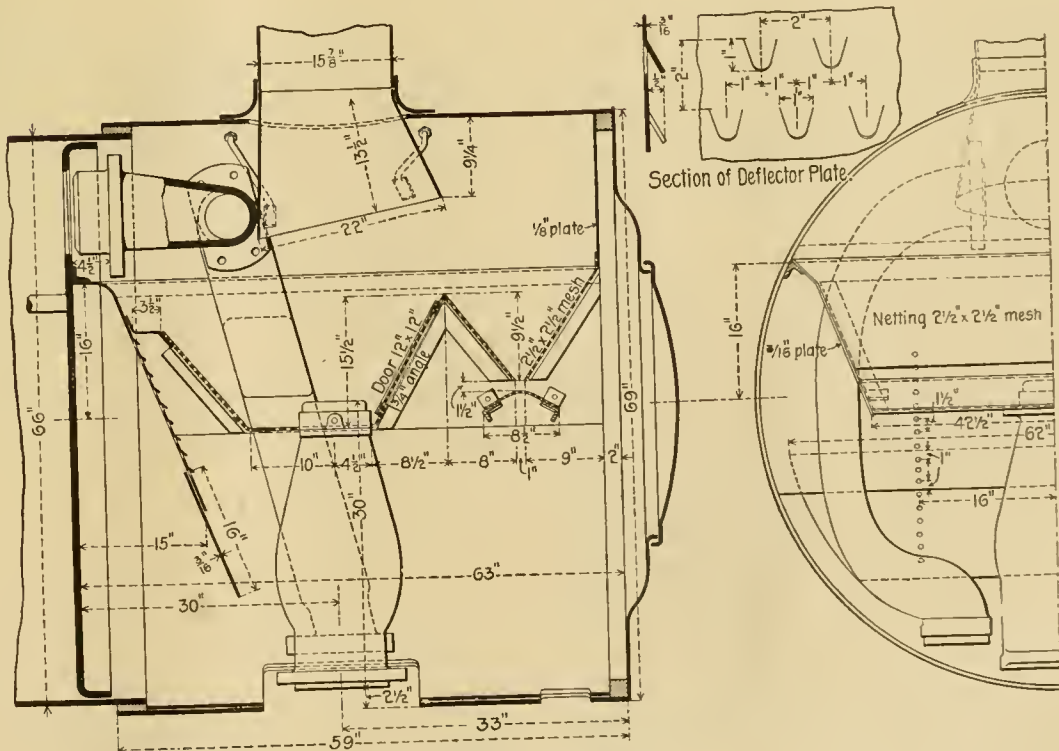

Fig. 6.—Wisconsin Central.

J. SNOWDEN BELL'S PATENT
SHORT SMOKE BOXES FOR LOCOMOTIVES.

engines were built by the Brooks Locomotive Works, and the reports are very satisfactory. The same general plan, with a slightly improved arrangement, was used on the Wisconsin Central passenger engines, illustrated on page 192 of our June, 1898, issue. This is shown in Fig. 6. The drawing is not exactly correct in regard to the sizes of the mesh. The forward portion has a mesh of $2\frac{1}{4}$ by $1\frac{1}{4}$ to the inch, and the door is 12 by 18 inches instead of 12 by 12 inches. The fact that the Brooks Locomotive Works continue to use this type of front end in their new designs is evidence of their satisfaction with it.

The Union Pacific method was described by Mr. J. H. McConnell at the 1898 convention of the Master Mechanics' Association. He uses diamond stacks and short front ends, after having experimented with a large number of different arrangements. Mr. McConnell's remarks were as follows: "In the arrangement of the front end of locomotives to prevent them from throwing large sparks, and clear themselves of cinders, much depends upon the condition of the fuel used. On some roads having a strong bituminous coal, with a coarse netting or perforated grate with large openings, and the diaphragm carried pretty well up into the bottom of the smoke

fessor Goss has shown (see American Engineer, October, 1896, page 255) that popular judgment in considering spark losses to be small is entirely wrong. Under ordinary working conditions in common practice they may amount to more than 10 per cent. of the fuel value of the coal.

THE NEW SUSEMIHL-TORREY SIDE BEARING FOR CARS.

In our October number of the current volume, page 339, we illustrated the form of roller side bearing, with which all of the passenger cars of the Michigan Central Railroad have been fitted, and now through the courtesy of Mr. Robert Miller, Superintendent of Motive Power of that road, we present engravings showing a modification of the same idea for application to freight cars, in which there is less room vertically than is required for the passenger type. The engravings show two forms of the bearing, with sections and details to illustrate its construction, and it is apparent that much less vertical head room is required than in the other form, but where

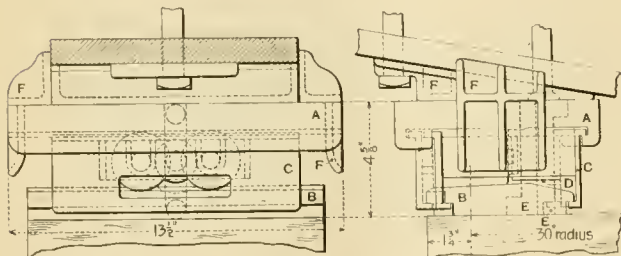

The New Susemihl-Torrey, Low Roller Side Bearing.

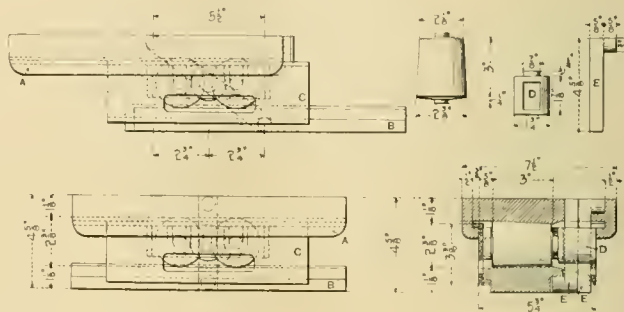

box, if the engines steam freely, they will clean the front end and still not throw any fire. On some of the Western roads, where the bituminous coal is heavy, I know of engines that are running with netting in the front end 2 by 2 or $\frac{1}{2}$ -inch opening. The engines are good steamers, and the front ends are perfectly clean. I believe the members of this Association will bear me out in this statement, that an engine which steams freely usually keeps the front end clean, but where the front end fills up the engine does not steam very well, and where it does fill up the engine is apt to throw fire. Where you use a lignite coal, it is a difficult matter to have the engine clean and not throw fire. The lignite coal in Wyoming is much of the character of wood. It requires a very fine netting to prevent the throwing of sparks. At the same time the deflecting plate must be dropped down pretty well, in order to clean the front end. The exhaust nozzles must be contracted to overcome the friction of the fine netting and the deflecting plate. In engines equipped with diamond stacks, the petticoat pipe can be arranged in such a way (by using rather large nozzles, and setting the petticoat pipe 2 inches above the nozzles, placing them 4 inches high and leaving a 5-inch opening on the side of the stack) that you can get good results with the Wyoming coal and the engines do not throw fire. Some years ago, on our road, we had extension fronts, and that season we had considerable difficulty with the Wyoming coal, and it was found advisable after five years' experience to remove the extension fronts and equip the engines with the ordinary front-end and diamond stack. At the present time we are getting good results running the large nozzle, steaming freely, and we do not have much trouble with fire."

The front-end problem is based upon the shortcomings of other parts of the locomotive, and the best way to solve it, and the only way to completely settle it, is to keep the sparks in the firebox and burn them there. In order to accomplish this the firebox, grates and heating surface must be considered, as well as the front end. The losses from sparks are not to be neglected, and it is not sufficient to merely provide for getting rid of them after they leave the fire box. Pro-

there is room enough to get in the form previously illustrated it is preferable, having larger rollers and fewer parts.

In the engravings the new bearing is seen to consist of the two plates A and B, with the carriage, C, between them. The view at the left showing the arrangement with the bolsters. The guide bar, E E, is made in two parts, which may extend by sliding upon each other. One is pivoted to the top casting, A, and the other to the bottom casting, B, and both pass through a swivel block, D, which has mortise to receive them. The swivel block is pivoted in the carriage, C, and controls the position of the carriage. The guide bars are held in a straight line and extend and contract telescopically. The carriage, C, has flanges at the top and bottom, whereby the bearing plates, carriage, rollers, the swivel casting and the guide bars are held together, so that they cannot separate or become deranged. To enable the car body to be lifted from the truck a clamping plate, F, of malleable iron is provided and shaped to conform to the pitch of the transom to which it is bolted. It has arms which catch over recesses formed in the top bearing plate, confining it laterally but permitting vertical movements independent of the plate.

The construction is such that in cars 34 feet long a displacement of 6 inches each side of the center is allowed between the car and the truck, which will permit the car to turn freely over a curve with a radius of 60 feet. The earlier design secures the top bearing plate directly to the transom of the car and the carriage and guide bar with the rollers go with the top bearing plate, and upon lowering the car upon the truck again the bottom end of the guide bar finds its place in the bottom bearing plate. It is difficult to see how any other arrangement can be made whereby the bearing can be kept within a vertical height of $4\frac{1}{2}$ inches, as is the case in this design.

CONSOLIDATION PUSHER LOCOMOTIVE, LEHIGH VALLEY R. R.—VAUCLAIN COMPOUND.

Through the courtesy of Mr. S. Higgins, Superintendent of Motive Power of the Lehigh Valley, we have received a photograph and extracts from the specifications of a very large and heavy pushing engine, recently built by the Baldwin Locomotive Works.

The engine is to work on that portion of the road known as the "Mountain Cut Off," extending from Coxton to Fairview, where there is a grade of 62 feet per mile and 20 miles long. The engine was designed to haul 1,000 net tons, exclusive of the engine and tender, and to handle such loads over this grade at a speed of 17 miles per hour with a good quality of "buckwheat" coal for fuel. The engine is to make the trip between Coxton and Fairview without stopping to take water. The limiting clearances were 10 feet 3 inches in width and 15 feet 4 inches in height.

The conditions imposed were severe, requiring very high tractive power and an enormous boiler capacity. The consolidation type was selected, and the weight on drivers is 202,232 pounds. The engine is therefore next to the heaviest ever built, and for heating surface, we believe, surpasses every engine now in service. The firebox is of the Wootten type, with 90 square

Working pressure	200 lbs.
Fuel	Hard coal
Firebox.	
Material	Steel
Length	120 in.
Width	108 in.
Depth	Front, 62½ in.
.....	Back, 60½ in.
Thickness of sheets.....	Sides, ¾ in.
.....	Back, ¾ in.
.....	Crown, ½ in.
.....	Tube (F), ¾ in.
.....	Tube (B), ½ in.
Tubes.	
Number	511
Diameter	2 in.
Length	14 ft. 7¼ in.
Heating Surface.	
Firebox	215 sq. ft.
Tubes	3599.6 sq. ft.
Total	4165.6 sq. ft.
Grate area	90 sq. ft.
Driving Wheels.	
Diameter outside	55 in.
Diameter of center.....	49 in.
Journals	9x12 in.
Engine Truck Wheels.	
Diameter	36 in.
Journals	6x12 in.
Wheel Base.	
Driving	15 ft. 0 in.
Total engine.....	23 ft. 10 in.
Total engine and tender.....	55 ft. ½ in.
Weight.	
On drivers	202,232*
On truck	22,850*
Total engine	225,082*
Total engine and tender.....	346,000*



Compound Consolidation Pushing Locomotive, Lehigh Valley R. R.

VAUCLAIN SYSTEM.

BALDWIN LOCOMOTIVE WORKS.

feet of grate area. The boiler is 80 inches in diameter, and it contains 511 tubes 2 inches in diameter and 14 feet 7 inches long.

The heating surface is 883 square feet greater than that of the Carnegie engine, illustrated on page 365 of our November issue. The cylinders of the Lehigh Valley engine are arranged on the VaucLain compound principle, and are 18 and 30 inches in diameter by 30 inches stroke. In addition to the enormous boiler capacity, the fact that the engine is a compound is most interesting, and that such a powerful machine should be compounded is a significant fact. Moreover, it is a four cylinder compound, and we do not see how any but the four cylinder could be used in such a design. It may be predicted that interesting history on the general subject of compound locomotives will be made with this engine, and its operation will be closely watched.

The weight per driving wheel is 25,300 pounds, which is exceeded by only one engine now running, the one already referred to. The total weight of 346,000 pounds is 12,000 pounds more than the Carnegie engine, and the wheel base is very nearly the same. This increase is partly due to the very large tender. The driving axle journals are 9 by 12 inches, and the driving wheels are 55 inches outside the tires. The tender has Fox pressed steel trucks.

The following table gives the chief dimensions of the engine:

Cylinders.	
Diameter (high pressure).....	18 in.
Diameter (low pressure).....	30 in.
Stroke	30 in.
Valve	Balanced piston.
Boiler.	
Diameter	80 in.
Thickness of sheets.....	¾ in.

Tender.	
Diameter of wheels.....	33 in.
Trucks	x Pressed S 1.
Journals	5 ft. x 9 in.
Tank capacity	7,000 gals.
Weight, empty	45,250 lbs.

*Weight includes water in boiler.

"ALL WORK FOR NOTHING."

The characters in the following exciting story, sent us by the Signal Engineer of one of the trunk railroads, are a Germo-Russo-Swede and his wife. The scene is laid at a double track drawbridge, combined with a grade, a bad curve and an interlocking plant, with derailing switches. The combination foreigner is the bridge and signal tender and the wife is his strategic board and adviser. The engine ran to the brink of the river and then turned over, with the pilot overhanging the edge. Had it not been for the noise made by the "Wif," there is no telling what would have happened.

The Story.

Signal Engineer. — Ry.:
Dear Sir: I have to reporten that yesterday Evening the train, Engine No. 845, run off from the trak. I have to open the Bridge, and I heare and see nothing from a approachen train, and so I pulled the delairing Switch, and I have the Bridge open about 8 or 10 Feet, as I heare the train Signal for go ahead, so I sended my Wif back for making noise and give Signal to stop, she cam 500 Feet, as she see's the train Commen along, as Engineer give a Signal to stop, but was all work for nothing.
A. STRACHJCKELSKIYONSON.

Bridge tender.

[The name is fictitious, being a mild form of the original, but otherwise the report is fac simile. No comment is necessary.— Editor.]

LOCOMOTIVE DESIGN—THE WORKING STRENGTH OF MATERIALS.

By F. J. Cole,

Mechanical Engineer Rogers Locomotive Works.

SPRINGS.

In designing elliptic springs for locomotives, experience shows that the best results are obtained by the use of a fibre strain in the hardened steel plates of from 70,000 to 80,000 pounds per square inch, figured from the static load. The former is desirable when the springs are unusually long, say over 44 or 46 inches, and the latter for springs shorter than 34 inches between centers of hangers, the aim being, of course, to make the most durable spring consistent with a soft, slow and easy motion. Some years ago on one of the large railroads, in order to reduce the excessive breakage and failure of locomotive driving springs, a large number were made with a fibre stress of 60,000 pounds per square inch, calculated from the static load they were to carry. While the results were satisfactory regarding their durability, yet the flexibility, or elasticity, was reduced below the point of easy motion, and complaints of rough riding engines became so numerous and persistent, that it was decided to increase the nominal or static stress to 75,000 pounds. This proved to be satisfactory from both the standpoint of durability and easy motion.

The weights on the driving wheels, resting upon the rails were obtained from all classes of engines on the road, and proper deductions made for the weight of parts not borne by the springs—such as wheels, boxes, eccentrics, rods, etc.—and the correct loading for each spring obtained. Then the proper

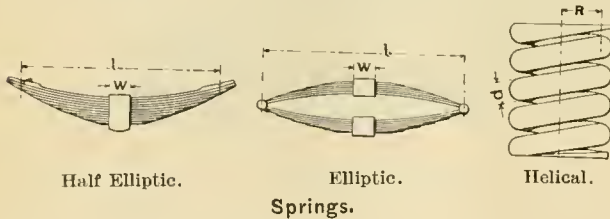

amount of metal was allowed for each spring, consistent with its length, load, width, etc., and the fibre stress of the metal kept as near the desired figure as practicable. For short springs it was found desirable to increase this to 80,000 pounds, and for springs of, say 42 inches and over, a soft, easy motion could be obtained with a fibre stress of 70,000 pounds. With these facts in view the spring business on the road was thoroughly gone over and systematized. The results obtained were a decided improvement in durability and easy motion. The number required for stock was very much reduced, as many of them differed but little from others and by making very slight changes in a number of instances the same spring could be used on several different classes of engines.

The following formulæ will be found useful in calculating the fibre stress and deflection of elliptic springs, in which:

- l = length of spring between centers in inches.
- W = width of spring band.
- n = number of plates in spring.
- S = fibre stress in plates per square inch = 75,000 pounds.
- P = load carried by spring (static).
- b = width of plates.
- E = modulus of elasticity = 30,000,000 pounds.
- D = deflection of spring in inches.
- h = thickness of plates.

$$P = \frac{2 s b h^2 n}{3 (1 - w)} \text{ reducing to } \left. \begin{array}{l} \frac{4,880}{1 - w} \text{ when } h = \frac{5}{16} \text{ inch.} \\ \frac{7,030}{1 - w} \text{ " } h = \frac{3}{8} \text{ inch.} \\ \frac{9,570}{1 - w} \text{ " } h = \frac{7}{16} \text{ inch.} \\ \frac{12,500}{1 - w} \text{ " } h = \frac{1}{2} \text{ inch.} \end{array} \right\} \text{When } b \text{ and } n = 1.$$

$$S = \frac{3 P (1 - w)}{2 b h^2 n}$$

$$\text{For half elliptic } D = \frac{3 P (1 - w)^3}{8 E b h^3 n}$$

$$\text{For full elliptic } D = \frac{3 P (1 - w)^3}{4 E b h^3 n}$$

The following table has been calculated from these formulæ for a uniform fibre stress of 75,000 pounds, 4 inches width of band and 1 inch width of plate. By its use the number of plates required can be obtained for a given length, width, and thickness, by multiplying the load in the column corresponding to the thickness of plates and length between centers, by the required width of plate, and dividing the product so obtained into the load the spring has to carry, the quotient will be the number of plates. Example: How many plates should a half elliptic spring contain, 36 inches long, $\frac{3}{8}$ inch plate and $3\frac{1}{2}$ inches wide, to carry 12,300 pounds?

12300
 $\frac{12300}{220 \times 3\frac{1}{2}} = 16$ plates, Deflection 1.71 inches. For the ordinary

lengths of locomotive springs, plates $\frac{3}{8}$ -inch thick are generally used. When they are very short, 5-16-inch thick can be used to better advantage, as a greater deflection can be obtained with a given fibre stress. Plates 7-16 inch and $\frac{1}{2}$ inch will be found useful for long springs and in special cases, where the width is narrow, it is advisable to reduce the height and number of plates.

TABLE NO. 1.

Loads and Deflections for Half-Elliptic Springs.

Fibre stress = 75,000 pounds per square inch.
 For full elliptic springs the deflection is twice that given in table.
 All spring bands four inches wide.
 For bands three inches wide assume the spring to be one inch longer.

Length Between Centers.	—One 5-16 by—		—One $\frac{3}{8}$ by—		—One 7-16 by—		—One $\frac{1}{2}$ by—	
	1 in. Plate.	Deflec- tion.	1 in. Plate.	Deflec- tion.	1 in. Plate.	Deflec- tion.	1 in. Plate.	Deflec- tion.
20	306	.51	439	.43	598	.36	781	.32
21	287	.58	413	.48	563	.41	734	.36
22	271	.65	390	.54	532	.46	694	.40
23	257	.72	370	.60	504	.51	658	.45
24	244	.80	351	.67	478	.57	625	.50
25	232	.88	335	.73	456	.63	595	.55
26	222	.97	319	.81	435	.69	568	.61
27	212	1.06	306	.88	416	.75	543	.66
28	203	1.11	293	.96	399	.82	521	.72
29	196	1.22	281	1.04	383	.89	500	.78
30	188	1.34	270	1.13	368	.96	481	.84
31	181	1.46	260	1.21	354	1.04	463	.91
32	174	1.57	251	1.30	342	1.12	446	.98
33	168	1.68	242	1.40	330	1.20	431	1.05
34	162	1.80	234	1.50	319	1.28	417	1.12
35	157	1.92	227	1.60	309	1.37	403	1.20
36	152	2.05	220	1.71	299	1.46	391	1.28
37	148	2.18	213	1.81	290	1.55	379	1.36
38	143	2.31	207	1.92	281	1.65	368	1.45
39	139	2.45	201	2.04	273	1.75	357	1.53
40	135	2.59	195	2.16	266	1.85	347	1.62
41	131	2.74	190	2.28	259	1.95	338	1.71
42	128	2.89	185	2.41	252	2.06	329	1.80
43	125	3.04	180	2.53	245	2.17	320	1.90
44	122	3.20	176	2.67	239	2.28	312	2.00
45	119	3.36	171	2.80	233	2.40	305	2.10
46	116	3.52	167	2.94	228	2.52	298	2.21
47	113	3.70	164	3.08	222	2.64	291	2.31
48	111	3.87	160	3.22	217	2.76	284	2.43
49	108	4.05	156	3.37	213	2.89	278	2.53
50	106	4.23	153	3.52	208	3.02	272	2.64

Probably 75 per cent. or more of all locomotive driving springs are made of plates $3\frac{1}{2}$ inches wide by $\frac{3}{8}$ inch thick.

Table No. 2, therefore, has been prepared, giving the working loads for lengths between centers of hangers from 20 to 50 inches, and for the different numbers of plates ranging from 4 to 26. The deflections for the various lengths are given in table No. 1.

From table No. 2 the working load for a spring of given length and number of plates, or for a given load and length, the number of plates required, may be obtained without any calculation.

In a general way it may be stated that for ordinary weights of locomotives and conditions of track, the deflection for driving springs should not be made less than $1\frac{1}{2}$ inches for smooth, easy riding. This would mean that when the conditions are observed under which the table is constructed, half elliptic springs of less than 33 or 34 inches long, when made of $\frac{3}{8}$ -inch steel, or 31 to 32 inches long, when made of 5-16-inch steel, should not be used.

TABLE NO. 2.
Working Loads for Half Elliptic Springs. Plates 3/4 Inches wide by 3/8-Inch Thick. Bands, 4 Inches Wide.

Length between Centers.	Number of Plates.																							
	4	5	6	7	8	9	10	11	12	13	14	15	16	17	18	19	20	21	22	23	24	25	26	
20	6,146	7,682	9,219	10,735	12,292	13,828	15,365	16,900	18,435	20,000	21,565	23,130	24,695	26,260	27,825	29,390	30,955	32,520	34,085	35,650	37,215	38,780	40,345	41,910
21	5,782	7,277	8,673	10,118	11,564	13,009	14,455	15,900	17,345	18,790	20,235	21,680	23,125	24,570	26,015	27,460	28,905	30,350	31,795	33,240	34,685	36,130	37,575	39,020
22	5,460	6,825	8,190	9,555	10,920	12,285	13,650	15,015	16,380	17,745	19,110	20,475	21,840	23,205	24,570	25,935	27,300	28,665	30,030	31,395	32,760	34,125	35,490	36,855
23	5,180	6,475	7,770	9,065	10,360	11,655	12,950	14,245	15,540	16,835	18,130	19,425	20,720	22,015	23,310	24,605	25,900	27,195	28,490	29,785	31,080	32,375	33,670	34,965
24	4,940	6,142	7,371	8,599	9,828	11,056	12,284	13,513	14,742	15,970	17,199	18,427	19,656	20,884	22,113	23,341	24,570	25,799	27,027	28,256	29,484	30,713	31,941	33,170
25	4,740	5,882	7,035	8,207	9,380	10,552	11,725	12,897	14,070	15,242	16,415	17,587	18,760	19,932	21,105	22,277	23,450	24,622	25,795	26,967	28,140	29,312	30,485	31,657
26	4,580	5,682	6,815	7,915	9,015	10,115	11,215	12,315	13,415	14,515	15,615	16,715	17,815	18,915	20,015	21,115	22,215	23,315	24,415	25,515	26,615	27,715	28,815	29,915
27	4,460	5,525	6,615	7,685	8,755	9,825	10,895	11,965	13,035	14,105	15,175	16,245	17,315	18,385	19,455	20,525	21,595	22,665	23,735	24,805	25,875	26,945	28,015	29,085
28	4,360	5,395	6,465	7,515	8,565	9,615	10,665	11,715	12,765	13,815	14,865	15,915	16,965	18,015	19,065	20,115	21,165	22,215	23,265	24,315	25,365	26,415	27,465	28,515
29	4,280	5,285	6,335	7,375	8,415	9,455	10,495	11,535	12,575	13,615	14,655	15,695	16,735	17,775	18,815	19,855	20,895	21,935	22,975	24,015	25,055	26,095	27,135	28,175
30	4,210	5,195	6,235	7,265	8,295	9,325	10,355	11,385	12,415	13,445	14,475	15,505	16,535	17,565	18,595	19,625	20,655	21,685	22,715	23,745	24,775	25,805	26,835	27,865
31	4,150	5,125	6,155	7,175	8,195	9,215	10,235	11,255	12,275	13,295	14,315	15,335	16,355	17,375	18,395	19,415	20,435	21,455	22,475	23,495	24,515	25,535	26,555	27,575
32	4,100	5,065	6,095	7,115	8,135	9,155	10,175	11,195	12,215	13,235	14,255	15,275	16,295	17,315	18,335	19,355	20,375	21,395	22,415	23,435	24,455	25,475	26,495	27,515
33	4,060	5,025	6,055	7,075	8,095	9,115	10,135	11,155	12,175	13,195	14,215	15,235	16,255	17,275	18,295	19,315	20,335	21,355	22,375	23,395	24,415	25,435	26,455	27,475
34	4,030	4,995	6,025	7,045	8,065	9,085	10,105	11,125	12,145	13,165	14,185	15,205	16,225	17,245	18,265	19,285	20,305	21,325	22,345	23,365	24,385	25,405	26,425	27,445
35	4,000	4,965	5,995	7,015	8,035	9,055	10,075	11,095	12,115	13,135	14,155	15,175	16,195	17,215	18,235	19,255	20,275	21,295	22,315	23,335	24,355	25,375	26,395	27,415
36	3,980	4,945	5,975	6,995	8,015	9,035	10,055	11,075	12,095	13,115	14,135	15,155	16,175	17,195	18,215	19,235	20,255	21,275	22,295	23,315	24,335	25,355	26,375	27,395
37	3,960	4,925	5,955	6,975	7,995	9,015	10,035	11,055	12,075	13,095	14,115	15,135	16,155	17,175	18,195	19,215	20,235	21,255	22,275	23,295	24,315	25,335	26,355	27,375
38	3,940	4,915	5,945	6,965	7,985	9,005	10,025	11,045	12,065	13,085	14,105	15,125	16,145	17,165	18,185	19,205	20,225	21,245	22,265	23,285	24,305	25,325	26,345	27,365
39	3,920	4,895	5,925	6,945	7,965	8,985	10,005	11,025	12,045	13,065	14,085	15,105	16,125	17,145	18,165	19,185	20,205	21,225	22,245	23,265	24,285	25,305	26,325	27,345
40	3,900	4,885	5,915	6,935	7,955	8,975	9,995	11,015	12,035	13,055	14,075	15,095	16,115	17,135	18,155	19,175	20,195	21,215	22,235	23,255	24,275	25,295	26,315	27,335
41	3,880	4,875	5,905	6,925	7,945	8,965	9,985	11,005	12,025	13,045	14,065	15,085	16,105	17,125	18,145	19,165	20,185	21,205	22,225	23,245	24,265	25,285	26,305	27,325
42	3,860	4,865	5,895	6,915	7,935	8,955	9,975	11,000	12,020	13,040	14,060	15,080	16,100	17,120	18,140	19,160	20,180	21,200	22,220	23,240	24,260	25,280	26,300	27,320
43	3,840	4,855	5,885	6,905	7,925	8,945	9,965	11,000	12,020	13,040	14,060	15,080	16,100	17,120	18,140	19,160	20,180	21,200	22,220	23,240	24,260	25,280	26,300	27,320
44	3,820	4,850	5,880	6,900	7,920	8,940	9,960	11,000	12,020	13,040	14,060	15,080	16,100	17,120	18,140	19,160	20,180	21,200	22,220	23,240	24,260	25,280	26,300	27,320
45	3,800	4,845	5,875	6,895	7,915	8,935	9,955	11,000	12,020	13,040	14,060	15,080	16,100	17,120	18,140	19,160	20,180	21,200	22,220	23,240	24,260	25,280	26,300	27,320
46	3,780	4,840	5,870	6,890	7,910	8,930	9,950	11,000	12,020	13,040	14,060	15,080	16,100	17,120	18,140	19,160	20,180	21,200	22,220	23,240	24,260	25,280	26,300	27,320
47	3,760	4,835	5,865	6,885	7,905	8,925	9,945	11,000	12,020	13,040	14,060	15,080	16,100	17,120	18,140	19,160	20,180	21,200	22,220	23,240	24,260	25,280	26,300	27,320
48	3,740	4,830	5,860	6,880	7,900	8,920	9,940	11,000	12,020	13,040	14,060	15,080	16,100	17,120	18,140	19,160	20,180	21,200	22,220	23,240	24,260	25,280	26,300	27,320
49	3,720	4,825	5,855	6,875	7,895	8,915	9,935	11,000	12,020	13,040	14,060	15,080	16,100	17,120	18,140	19,160	20,180	21,200	22,220	23,240	24,260	25,280	26,300	27,320
50	3,700	4,820	5,850	6,870	7,890	8,910	9,930	11,000	12,020	13,040	14,060	15,080	16,100	17,120	18,140	19,160	20,180	21,200	22,220	23,240	24,260	25,280	26,300	27,320

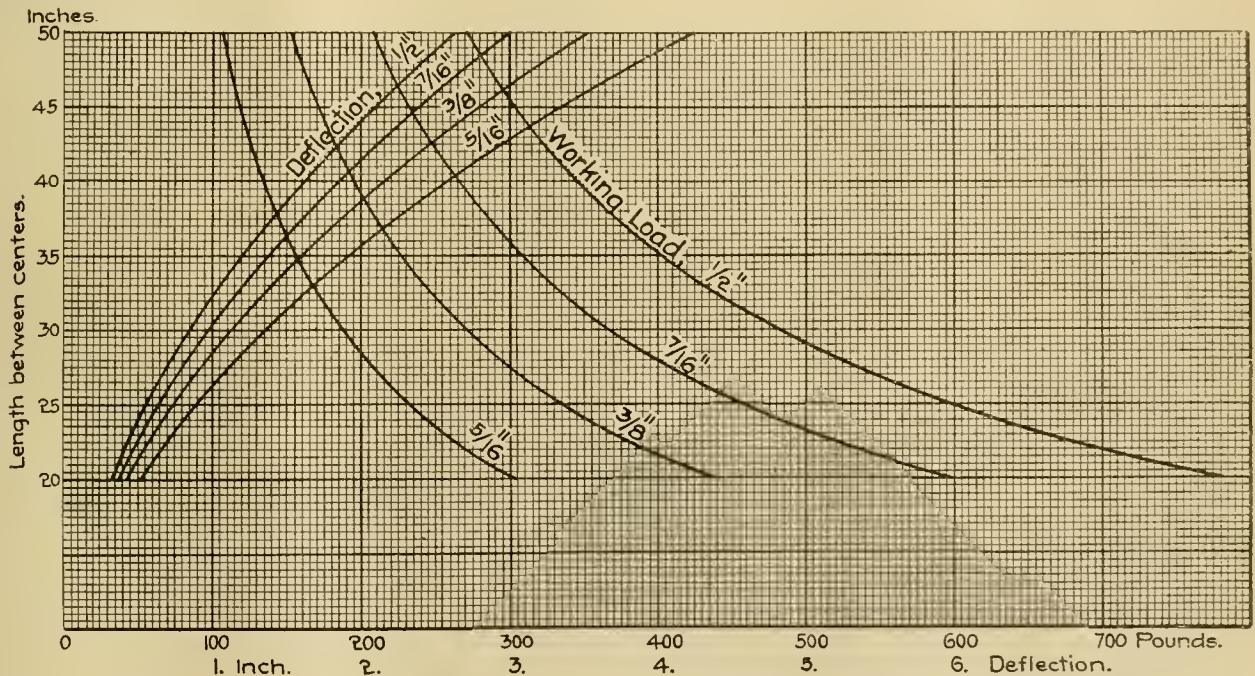

Diagram of Working Loads and Deflections for Half Elliptic Springs.

Plates 3/8 to 1/2 inch thick and 1 inch wide, bands 4 inches wide. Example: Required the working load and deflection of a spring 40 inches long, 4 inches wide, having 15 plates 3/8 inch thick. Follow the horizontal line 40 to its intersection with the curved line marked "working load, 3/8 inch," then vertically to the base line, and read off 195 pounds. Then 195 x 4 x 15 = 11,700 pounds working load. Similarly for the deflection, to the curved line marked "deflection 3/8 inch" and then to the base line and read off 2.15 inches, the amount the spring will deflect from the free to the loaded height, which amount is independent of the width and number of plates.

For full elliptic springs the deflection is twice that given in the table; the limit would be reached at 25 inches for 3/8-inch steel, and at 23 inches for 5-16-inch steel.

For passenger engines 2 inches deflection would give better results. Where the conditions will allow a long spring to be used, its durability would be much increased by making the plates 5, or even 6 inches in width, decreasing the stress to 60,000 pounds per square inch, and increasing the thickness to 7-16, or 1/2 inch, but maintaining the desired deflection. The use of driving springs over 3 1/2 inches wide is in most cases restricted to those below the driving boxes, known as "under-hung."

In calculating the working loads and deflections for helical springs made of solid circular bars, the formulæ generally used are as follows:

Let P = working load carried by spring = one-half the load when solid.
d = diameter of steel bar.
R = radius to center of coil.

D = deflection of spring under working load.
G = modulus of shearing elasticity, assumed to be 13,000,000 pounds.
L = length of bar before coiling.
S = working shearing fibre strain in bar, 40,000 to 50,000 pounds.
M = number of coils.
H_s = height when solid.
H = height when free.
π = 3.1416.
T = tapered length of bar.

$$\text{Then } P = \frac{S \pi d^3}{16 R} \quad L = \frac{2 \pi R H_s}{d} \quad M = \frac{L}{\pi 2 R}$$

$$M = \frac{H_s}{d} \quad L = M 2 \pi R \quad T = \frac{\pi 2 R}{2} + L$$

$$D = \frac{2 R S L}{d G} \quad D = \frac{H}{8}$$

TABLE No. 3.
Working Loads and Deflections for Helical Springs.

$$P = \frac{S\pi d^3}{16R} \quad D = \frac{2RSL}{dG}$$

Outside Dia.	40,000 lbs.		40,000 lbs.		40,000 lbs.		40,000 lbs.		40,000 lbs.		41,000 lbs.		42,000 lbs.		42,000 lbs.		43,000 lbs.		44,000 lbs.		44,000 lbs.		46,000 lbs.		47,000 lbs.		48,000 lbs.		49,000 lbs.		50,000 lbs.		50,000 lbs.		Outside Dia.						
	1 1/8" Dia.		1 1/8" Dia.		1 1/8" Dia.		1 1/8" Dia.		1 1/8" Dia.		1 1/8" Dia.		1 1/8" Dia.		1 1/8" Dia.		1 1/8" Dia.		1 1/8" Dia.		1 1/8" Dia.		1 1/8" Dia.		1 1/8" Dia.		1 1/8" Dia.		1 1/8" Dia.		1 1/8" Dia.		1 1/8" Dia.								
	Load	Def.	Load	Def.	Load	Def.	Load	Def.	Load	Def.	Load	Def.	Load	Def.	Load	Def.	Load	Def.	Load	Def.	Load	Def.	Load	Def.	Load	Def.	Load	Def.	Load	Def.	Load	Def.	Load	Def.							
7"	7260	.222	6215	.238	5336	.256	4525	.275	3902	.304	3253	.329	2749	.365	2242	.397	1847	.445	7"							
6 3/4"	7597	.203	6532	.218	5578	.234	4729	.252	4076	.279	3496	.302	2868	.335	2338	.365	1925	.409	6 3/4"							
6 1/2"	7969	.184	6817	.196	5844	.213	4951	.230	4265	.254	3552	.276	2990	.306	2444	.331	2011	.375	1630	.422	6 1/2"							
6 1/4"	8376	.167	7194	.179	6136	.193	5196	.209	4474	.231	3723	.251	3142	.279	2558	.304	2104	.343	1704	.386	1355	.438	6 1/4"						
6"	7576	.161	6459	.174	5466	.188	4703	.209	3991	.228	3299	.253	2683	.276	2207	.311	1789	.351	1420	.399	1105	.456	6"						
5 3/4"	6815	.156	5765	.169	4957	.188	4120	.205	3472	.229	2824	.250	2320	.282	1877	.318	1491	.362	1160	.414	879	.3	477	5 3/4"						
5 1/2"	6099	.151	5240	.169	4352	.184	3665	.205	2979	.224	2445	.253	1977	.287	1569	.327	1220	.374	924	.3	432	679	.502	5 1/2"						
5 1/4"	6475	.134	5558	.149	4612	.164	3881	.183	3152	.201	2555	.227	2089	.257	1657	.293	1287	.336	974	.2	388	716	.453	5 1/4"						
5"	5916	.132	4905	.144	4123	.162	3346	.178	2742	.202	2213	.229	1754	.262	1361	.301	1030	.348	756	.406	534	.380	5"						
4 3/4"	5237	.126	4395	.142	3565	.157	2919	.178	2354	.203	1864	.232	1445	.267	1093	.309	801	.361	566	.428	4 3/4"					
4 1/2"	4712	.124	3815	.137	3120	.156	2513	.178	1988	.209	1540	.235	1163	.273	852	.319	601	.379	405	.456	4 1/2"					
4 1/4"	4103	.118	3352	.135	2694	.155	2130	.178	1648	.205	1243	.239	910	.280	641	.333	431	.401	4 1/4"				
4"	3620	.116	2908	.133	2291	.153	1772	.177	1335	.207	976	.244	687	.290	461	.350	286	.423	4"				
3 3/4"	3934	.098	3155	.113	2485	.131	1917	.152	1442	177	1087	.197	740	.250	496	.303	307	.367	3 3/4"					
3 1/2"	3449	.091	2711	.109	2087	.128	1567	.150	1142	.178	802	.213	537	.259	331	.315	3 1/2"				
3 1/4"	2982	.090	2291	.106	1716	.125	1248	.111	875	.179	585	.219	360	.267	3 1/4"				
3"	2539	.086	1897	.102	1376	.123	962	.148	642	.181	394	.222	3"				
2 3/4"	2120	.082	1533	.098	1169	.120	711	.148	336	.182	2 3/4"			
2 1/2"	17.1	.077	1202	.094	797	.118	487	.146	2 1/2"		
2 1/4"	1374	.072	907	.091	552	.113	2 1/4"		
2"	1052	.067	637	.085	2"	
1 3/4"	753	.061	461	.081	1 3/4"
1 1/2"	920	.041	1 1/2"

The ratio between R and d should be about 2 to 1, that is, a spring made of 1-inch diameter bar should be 5 inches outside diameter. If less than this the diameter of the bar becomes too great for the diameter of coil. This will be noticed also in calculating the deflection. The working height under the load is assumed to be midway between the free and solid heights, the working load being considered as half the load required to bring the spring solid. The deflection under the working load should be about one-eighth, or when solid one-

deflection is given for one coil under the working load, and to obtain the deflection for any height multiply the deflection in the table by the number of coils.

NARROW-GAUGE LOCOMOTIVE FOR THE CAUCA RAILWAY.

The locomotive illustrated by the engravings herewith, has

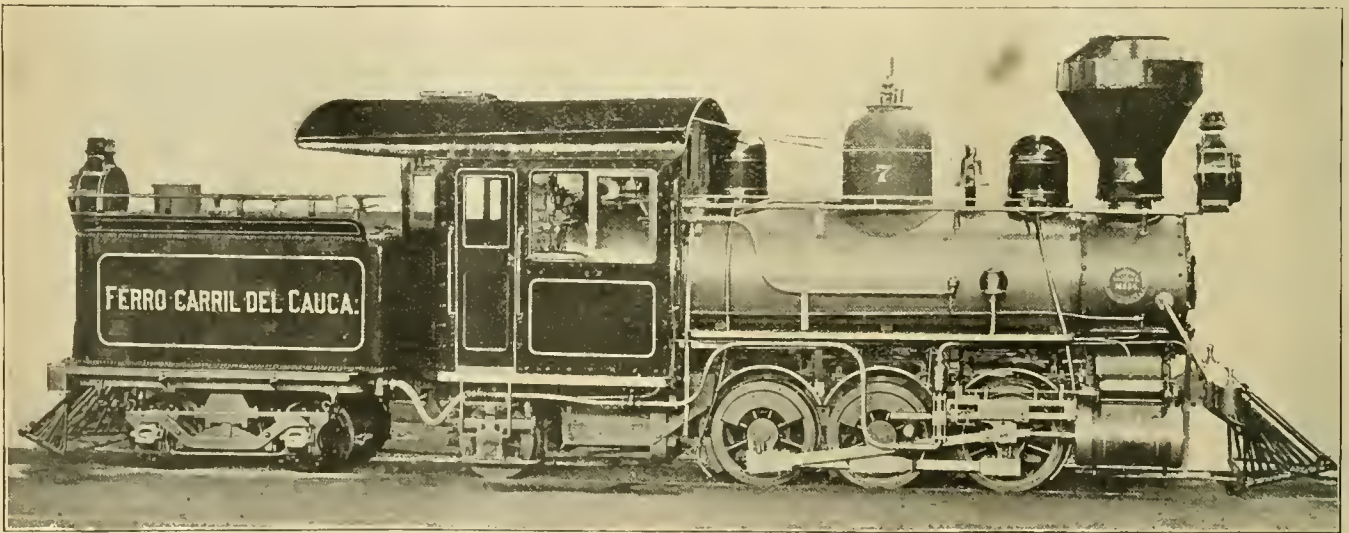

Narrow Gauge Locomotive, Cauca Railway, United States of Colombia.
Built by the BALDWIN LOCOMOTIVE WORKS, from Designs by M. N. FORNEY, M. E.

quarter of the free height. A spring made of 1-inch bar, 5 inches outside diameter, 6 inches solid, would be 8 inches high when free and contain $\frac{H_s}{d} = 6$ coils, length of bar $M 2 \pi R = 75.4$ inches, tapered length of bar $\frac{2 \pi R}{3} + L = 81.7$ inches. Deflection under working load $= 6 \times .162$ (from table) $= .972$. From Table 3 (which is adapted from one prepared by Mr. J. R. Onderdonk) a spring of suitable strength, size of bar, outside diameter and deflection may be selected. The working load is of course independent of the height, it remaining constant whether the spring is one or any number of coils high. The

recently been completed at the Baldwin Locomotive Works for the Cauca Railway, in the United States of Colombia, South America, and has some novel and interesting features. The plan of the engine was proposed by Mr. M. N. Forney, whose office is at 41 Cortlandt street, New York, and who, we may add, is now devoting his time to work of this kind, and the complete design and drawings were worked out in the drawing-room of the Baldwin Works.

The conditions to be fulfilled were exacting and somewhat peculiar. The road is of 3-foot gauge, with curves of a minimum radius of 200 feet, and therefore it was stipulated that

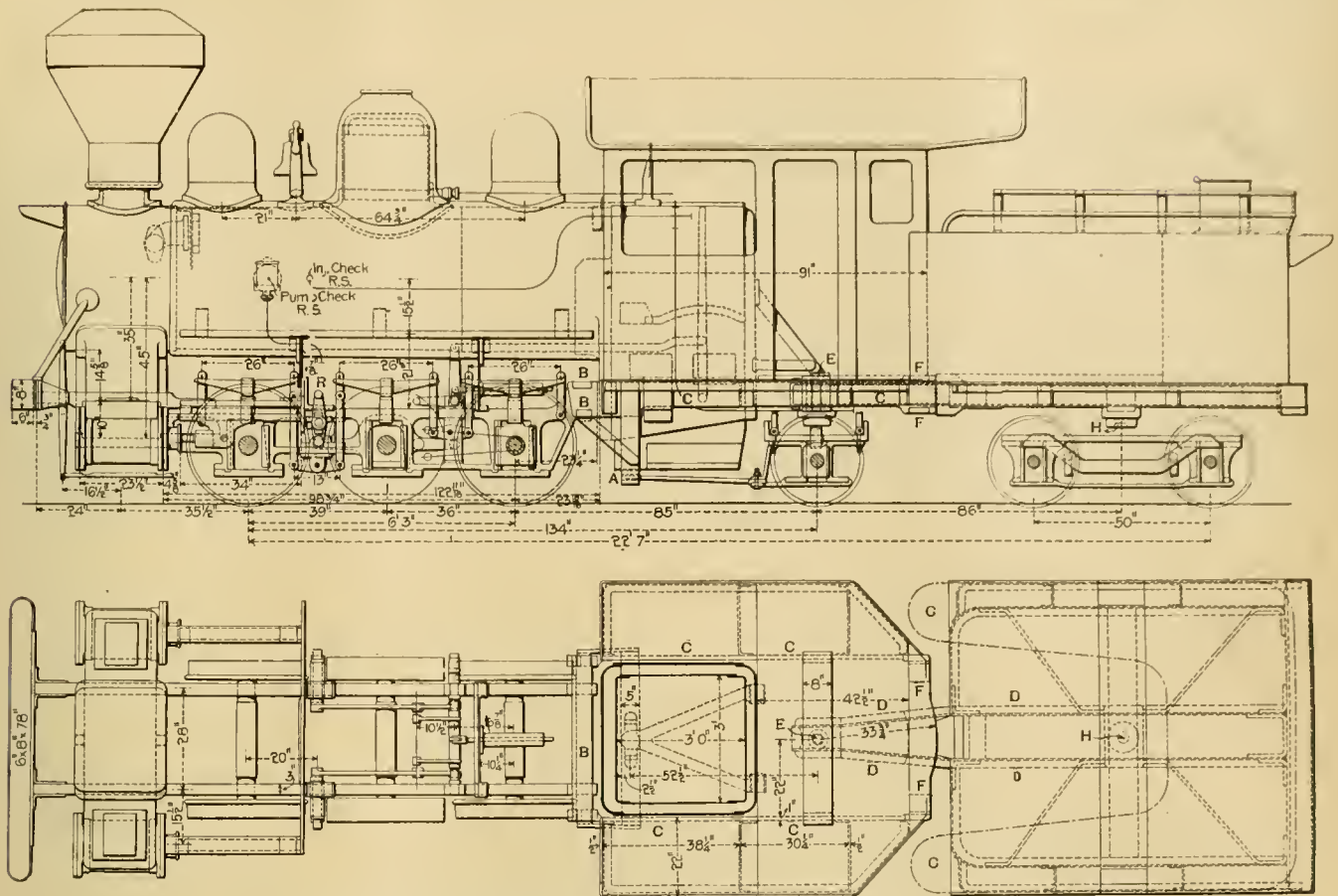

Narrow Gauge Locomotive, Cauca Railway, United States of Colombia.
 Built by the BALDWIN LOCOMOTIVE WORKS, from Designs by M. N. FORNEY, M. E.

the wheel-base measured from the centre of the front driving-axle to that of the trailing truck must not exceed 16 feet. It was thought that a shorter wheel-base would be desirable. The rails on the road weigh 30 and 40 pounds per yard. There are no turntables on the line, so the locomotive must run both ways. The requirements of the traffic demanded adhesive weight of 42,000 pounds on the driving-wheels, which, owing to the lightness of the rails, had to be distributed on three pairs of wheels, and it was considered essential that this weight should be uniform, and therefore no part of the water or fuel could be carried on them. It was also stipulated that the tank should carry 1,000 gallons of water, with a sufficient supply—about a cord—of wood for fuel. The first intention was to carry these on a four-wheeled trailing truck, thus making the engine of what has come to be known as the "Forney" type.

The difficulty was encountered of getting room enough for the fuel and water if they were carried on such a truck, without lengthening the wheel-base too much, for the short curves on which the engine must run. The difficulty will be apparent if it is observed that a space of about 4½ feet should be provided behind the boiler for the engineer and fireman to work in, and a tank of the capacity required must be about eight or nine feet long. If this was supported on a four-wheeled trailing truck, the latter must be located so far back as to lengthen the wheel-base too much. It was therefore determined to place a pony-truck below the footboard, as shown in the engravings. This truck consists of the usual A-shaped frame, pivoted to a center pin at A, Fig. 2. The driving-wheels were grouped together as closely as possible, to leave room for the rocking-shaft at R, and were located between the fire-box and smoke-box—their wheel-base being only 6 feet 3 inches. This arrangement permitted the fire-box to be made as wide as the distance over the outside of the tires, and it might have been made still wider had it been thought desirable to do so. Two strong bars or braces, B B, were bolted to the back ends of the main frames and extended outward beyond the outside of the fire-box, and slab frames, C C, were attached to their outer ends and extended backward on each side of the fire-box, and supported the footboard and ca.. By locating the single pair of truck wheels below the footboard they could be brought up near the fire-box, so that the total wheel-base of the engine was only 13 feet 4 inches. The tank was then placed on a separate frame made of

channel bars, the two middle ones of which, D D, were extended forward under the footboard and were attached to a center pin, E, directly over the pony-truck axle. A four-wheeled side-bearing truck of an ordinary form of construction was then placed below the tender frame, to carry the tank. To the back ends of the slab-frames two bars, F F, were fastened, and the extended channel bars, D D, passed between them, and had sufficient play so as to permit of any vertical movement of the engine and tender in relation to each other, due to inequalities of the road. The tender frame, of course, turns about the center pin E. For this reason the back end of the cab was made octagonal in form, as shown in the plan, Fig. 3, so that the front ends or legs of the tank may turn about the pin E, without coming in contact with the cab. As the four-wheeled tender truck can turn freely about its own center-pin at H, and the tender frame can turn about the pin E, and also rise and fall in relation to the engine, it will be seen that the engine has the utmost flexibility and capacity of adaptation to vertical and horizontal inequalities of the road. Nearly the whole weight of the engine is utilized for adhesion; a large roomy cab is provided with ample space behind the fire-box and transversely on the footboard. On narrow gauge engines this space is often very much contracted. The grate is 3 by 3 feet, which was considered ample, but could have been made larger had it been considered desirable to do so.

While the design was under consideration the question was asked why not use a simple four-wheeled tender instead of the arrangement which was adopted. The objection to a four-wheeled tender would be that it would be very unsteady, especially when running backward, whereas with the plan shown the tender frame is supported at E, and also on the centre of the four-wheeled truck, so that vertical steadiness is secured, with perfect lateral flexibility.

The general plan, it is thought, could with much advantage be applied to larger locomotives of any gauge.

The following are the principal dimensions of this engine:

Cylinders, 12 by 16 inches.

Driving-wheels, 33 inches diameter.

Weight of engine, about 48,000 pounds; weight of tender, about 17,000 pounds.

Waist of boiler, 40 inches diameter; tubes, 1¾ inches diameter and 9 foot 6 inches length.

Fire-box, 36 by 36 inches inside.

Truck wheels, 24 inches diameter.

CIRCULAR HEADLIGHT, CHICAGO, MILWAUKEE & ST. PAUL RY.

IMPROVEMENTS IN LOCOMOTIVE OPERATION—NORTH-ERN PACIFIC RAILWAY.

The usual form of locomotive headlight is difficult and expensive to maintain, and in order to secure an improvement in this respect and also to obtain a more uniform appearance of the attachments upon the tops of boilers, the mechanical department of the Chicago, Milwaukee & St. Paul Railway several years ago designed and constructed headlights of circular section, as illustrated in the accompanying engraving.

The headlight case is in the form of a vertical cylinder. It is made of No. 18 sheet steel, fitted with a glass plate about 18 inches in diameter, and riveted at the bottom to a 1/4 by 1/4 inch ring. The base is of cast iron, shaped to fit the smoke box and furnished with a groove at its top to receive the ring at the bottom of the casting. Seven lugs on the base casting furnish means of attaching the casing. The top of the lantern is made in the form shown, giving ample ventilation, and yet preventing wind from entering the casing. The lamp, with oil cup and reflector, is mounted on a turntable of thin sheet

The railroads of the United States have much to learn from the policy and the records of performance of the Northern Pacific Railway, particularly during the past year. Some eight years ago the present General Manager, Mr. J. W. Kendrick, formulated, in a general way, a plan for improving the operating conditions in which grade reductions, increasing the power and continuous hauling capacity of locomotives and increasing train loads and carloads held important places. These plans, while not yet completely carried out, have not been materially altered, and they have resulted in a noteworthy decrease in the cost of operation per ton mile. All of the returns are now calculated upon this intelligent basis. The plan was far-sighted and the most important factor in carrying it out has been an intelligent and loyal co-operation of all the officers of the company.

The schedule speeds of trains, while somewhat improved, have not been changed enough to affect the cost of operation,

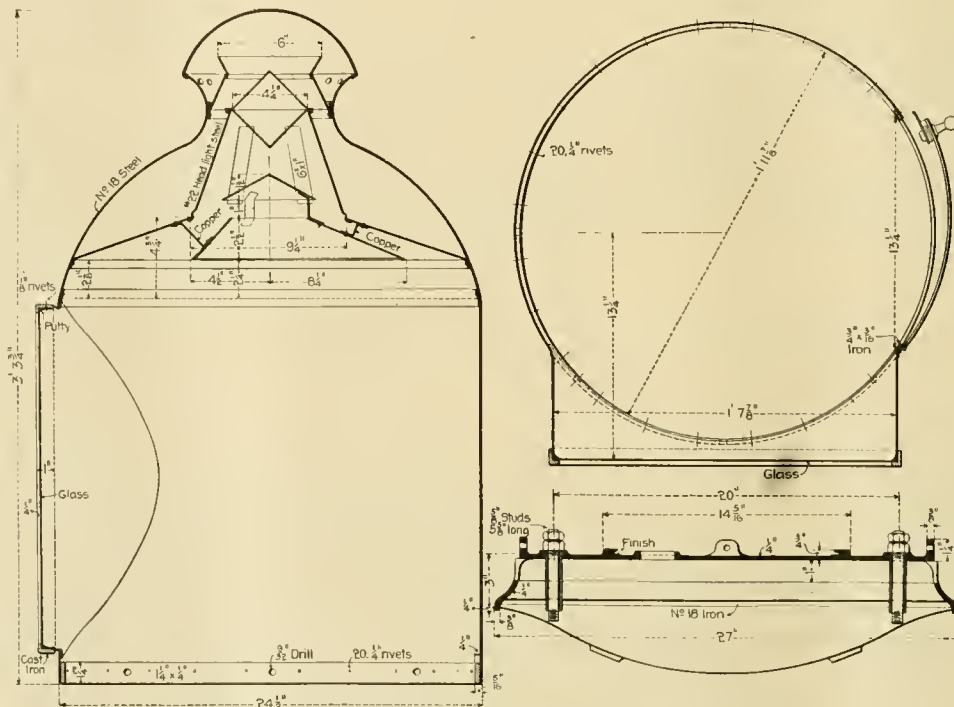

Circular Steel Headlight.—Chicago, Milwaukee & St. Paul Ry.

steel, which is carried on a dished plate of steel 1-16 inch thick, that is slid into grooves cast in the headlight base. The casing has a door about 13 inches wide on the left side, giving easy access to the lamp. Air is admitted through an elliptical hole in the base casting, which is covered by a strainer attached to the lamp base and so located as to register with the hole in the casting when the lamp and reflector are turned into position. The amount of air admitted may be adjusted by a slide. The open space under the cast iron base is packed with asbestos.

The cost of this headlight is about three dollars more than one of the ordinary form complete, including the lamp platform and brackets, but inasmuch as one of the latter will sometimes require complete overhauling after less than two years' service, and since the circular form is an admirable one for strength and durability, a material saving is expected. Aside from this, the appearance of the circular headlight is neat and attractive. Used in connection with a dome and sand box, which are of helmet form, it is in good taste and gives a uniform and tasteful look to an engine.

but the weight of trains and the distances covered by the locomotives have been greatly increased. The two most important factors are reductions of grades and increased power of locomotives, as contributive to the latter, the assignment of the engines to the various divisions has been entirely revised and arranged with a view of using each engine where it will operate most favorably. The cutting down of grades was done very gradually, at first starting on the east end of the line where the traffic was heaviest, and extending to the heavier work when conditions warranted. The ultimate object is to haul about 1,200 tons per train from St. Paul to the Rocky Mountains without breaking the trains. This not only means effective and economical operation of locomotives, but incidental advantages are gained by saving delays and expenses due to switching trains about on the way. The length of locomotive runs has also been greatly increased, and they are now run through instead of changing at the terminals of districts, and the result in passenger service is to reduce the number of engines in service about 50 per cent., several of the less important district terminals having been abandoned altogether. The

freight engines have also been redistricted for the reasons given. Further advantage has been gained by the use of compounds.

In the use of compound locomotives this road has avoided a serious mistake that many have made by not designing the compounds to be powerful enough. The power of the engine is quite as important as the type, and this has not been generally recognized. This fact accounts for a great deal of the apathy and even doubt which is seen in the estimate of the value of the compound feature. The Northern Pacific records are convincing as to the advantages of the type, and all new freight engines now building are to be compounds.

The following table taken from the annual report of the general manager shows the engine ratings upon the various divisions prior to 1893, in 1897 and 1898, and also the intended future rating. These remarkable figures result from a combination of the factors previously mentioned and they constitute an example which is worthy of the most careful study, contributing as they do to operating the road for 46.9 per cent. of the gross earnings:

Division and District.	Tonnage.			
	to 1893. Prior	1897.	1898.	Future.
Lake Superior, Second.....	650	E 1,350 W 1,350	E 1,350 W 1,350	E 1,350 W 1,350
Minnesota, Second.....	700	E 1,350 W 1,400	E 1,500 W 1,500	E 1,500 W 1,500
Manitoba, First.....	800	E 1,050 W 1,050	E 1,500 W 1,350	E 1,500 W 1,500
Dakota, First.....	840	E 1,350 W 1,200	E 1,350 W 1,200	E 1,350 W 1,200
Dakota, Second.....	700	E 1,000 W 1,000	E 1,000 W 1,000	E 1,350 W 1,350
Missouri, First.....	425	E 675 W 675	E 1,000 W 875	E 1,350 W 1,350
Missouri, Second.....	425	E 715 W 750	E 875 W 875	E 1,350 W 1,350
Yellowstone, First.....	625	E 1,200 W 850	E 1,250 W 875	E 1,500 W 1,350
Yellowstone, Second.....	625	E 1,200 W 850	E 1,250 W 875	E 1,500 W 1,350
Montana, First.....	E 1,000 W 650	E 1,500 W 1,000	E 1,500 W 1,000	E 1,500 W 1,000
Montana, second.....	E 375 W 750	E 1,000 W 1,000	E 1,000 W 1,000	E 1,200 W 1,000
Rocky Mountain, First.....	E 400 W 375	E 1,000 W 1,050	E 1,200 W 1,050	E 1,200 W 1,200
Rocky Mountain, Second.....	E 400 W 400	E 840 W 900	E 1,000 W 950	E 1,200 W 1,200
Idaho, First.....	E 450 W 450	E 1,000 W 1,000	E 1,065 W 1,065	E 1,200 W 1,065
Idaho, Second	E 525 W 640	E 900 W 875	E 900 W 900	E 1,200 W 1,200
Idaho, Third.....	E 650 W 500	E 1,500 W 820	E 1,500 W 1,125	E 1,500 W 1,200
Pacific, Ellensburg to Easton...	E 594 W 810	E 900 W 900	E 900 W 1,225	E 1,000 W 1,225
" Easton to Lester.....	E 405 W 810			
" Lester to Tacoma.....	E 525 W 525	E 620 W 620	E 1,100 W 1,100	E 1,100 W 1,100

During the month of September last the average tonnage in one direction on the first of these divisions was 1,577 tons per train for the 30 days.

The locomotive equipment has been increased in power, notwithstanding the fact that the actual number of engines in use has decreased. This is due to the purchase of the following new and powerful engines:

Number.	Type.	Weight on drivers.	Total weight.
18.....	10 wheel	112,000 lbs.	155,500 lbs.
18.....	10-wheel	126,000 lbs.	172,500 lbs.
7.....	10-wheel	131,800 lbs.	173,800 lbs.

The increase in train weights for two periods of six months each is as follows:

	Gross tons per engine mile.		Inc., pr. ct.	Gross tons per train mile.		Inc., pr. ct.
	1897.	1898.		1897.	1898.	
January	392	474	20.92	690	679	13.16
February	401	497	23.94	619	710	14.70
March	430	508	18.14	643	716	11.35
April	453	521	15.00	601	727	20.96
May	470	523	11.00	615	724	17.70
June	478	521	9.00	629	698	11.00

Twelve engines were purchased from the Montana Union Railway and 95 light, 17 by 24 inch, eight wheel engines were retired. With the addition of 55 engines, the total decrease during the year was 40, leaving a total of 542 on the list. The

effect of this on the power of the equipment is shown in the following table:

	June 30, 1897.	June 30, 1898.	Inc. or Dec.	Inc. or Dec.
Number of engines.....	582	542	D. 40	D. 6.9%
Weight on drivers.....	42,767,565	44,432,965	I. 1,665,400	I. 3.89%
Total weight.....	55,718,770	56,616,520	I. 897,750	I. 1.61%
Number of road engines.....	505	460	D. 45	D. 8.9%
Total horse power.....	249,275	263,625	I. 14,350	I. 5.8%

This horse power was taken from indicator cards and represents that which the engines develop in continuously sustained service. These figures, showing an increase of 5.8 per cent. of horse power, with a decrease of 8.9 per cent. in the number of engines, need no comment, except the remark that perhaps it will be found that the stresses on the 56 and 72 pound rails used as standards on the road may show them to be too light for the service required.

Among the other improvements included in the general scheme are new designs of coaling stations, with bins holding 35 tons of coal, which is weighed for the engine records by the ingenious dynamometer devised by Mr. E. H. McHenry, Chief Engineer of the road. In these the bins are hung upon rods inclined at such an angle from the perpendicular as to cause a thrust of one-tenth of the weight against the dynamometer. The weight is indicated by a gauge which is in sight of the fireman, who can tell the exact amount of coal chuted into the engine tank. Water stations have also received attention, and the reinforcement of old cars to increase their capacity from 40,000 to 50,000 lbs., has been applied to 5,586 cars, giving an increase of 55,860,000 lbs. in carrying capacity. The attendant increase in weight of a car is about 200 lbs., and the improvement is equivalent to 930 new 60,000 lb. cars.

In making these changes a liberal, far-sighted policy is kept in mind, and in many ways the expenditures of a number of years are made to contribute now to the decrease in the cost of operating the road. The method of keeping the records is admirable, the tonnage basis being used throughout even for oil and waste. The monthly records on the entire road are distributed among the operating officers and each is enabled to keep very close watch of the expense of the work under his charge. The necessity for knowing the cost is fully appreciated and the information appears to be used co-operatively for improvement.

THE U. S. REPAIR SHIP "VULCAN."

In the annual report of Commodore Melville, Chief of the Bureau of Steam Engineering of the United States Navy, the following statement is made in regard to the value of repair ships:

In the last report attention was called to the desirability of making such preparation for the fitting out of a vessel which would be a floating repair shop as would enable the work to be done with great rapidity when needed. Immediately on the prospect of war the bureau again brought this matter to the Department's attention, and the steamer Chatham was bought, set aside for this purpose and renamed the Vulcan. The work of installing the machine tools, cupola, forges, brass furnaces, etc., was pushed as rapidly as possible, as well as the selection of a force of skilled mechanics. A large and well chosen outfit of stores of all kinds was also supplied.

The Vulcan arrived at Guantanamo on July 1 and proved of the highest usefulness to the fleet, making repairs of all kinds and furnishing much needed supplies to every department of nearly every vessel. At the end of August reports from her officers showed that she had made repairs to sixty-three ships and had supplied stores to sixty. Her unusual facilities and the large number of skilled mechanics on board (about 100) enabled her to make repairs of all kinds, including hull work, gun mounts, dynamos, main steam pipes, main piston rods (for small ships), brass castings without end, and iron castings in considerable quantity. This last is specially interesting as the first instance of the successful use of a cupola on shipboard.

The steam turbine is being watched carefully by the Bureau of Steam Engineering of the navy, but, according to the latest report, it is not yet considered as an unqualified success.

COMMUNICATIONS.

GRATE AREAS, HEATING SURFACES AND CYLINDER VOLUMES.

Editor "American Engineer:"

In your October issue there appeared a communication on this subject by Mr. C. M. Higginson, in which he establishes from his experience the ratios that should exist between the grate areas and cylinder volumes of locomotives for road service when western coals are used for fuel. This method of computing grate areas is often advocated, but it has always appeared to me as erroneous and misleading. With a given quality of fuel, the size of the grate needed is dependent upon the rate at which steam must be produced, regardless of whether that steam is used in an 18 or 23-inch cylinder. If the size of the cylinder were in all cases proportional to the steam consumption per minute when the engine is doing its maximum work, the required grate area would bear a fixed ratio to the cylinder volume; but, as the cylinder volume is not an exact indication of the steam consumption, a fixed ratio is, in my opinion, unquestionably wrong.

Mr. Higginson advocates a ratio of 2.4 square feet of grate per cubic foot of cylinder volume. For most road engines this is too small, particularly if the engines are for fast freight or passenger service. As showing the fallacy in a fixed ratio I would ask if any careful designer, be he railroad official or locomotive builder, would decide on a grate area for a 20"x24" locomotive without knowing anything more about the engine? Would anyone use a ratio of 2.4, which would only give 21 square feet of grate, without knowing something of what is expected of the engine? Is it not evident that if the engine is to haul heavy passenger trains at high speeds its grate area should be larger than if it is to be used in slow freight service?

The fact is that the ratio of 2.4 applies fairly well to many of the modern mammoth freight engines, such as the Pennsylvania Class H-4, the Great Northern engines, or the enormous consolidation engine for the Union Railway of Pittsburg, which you illustrated last month, for the reason that these engines do the work at very slow speeds; but the figure is not suitable for engines of moderate size intended for faster service. In the following table I give a few particulars of a number of engines. The engines are arranged approximately in the order of their size, the heaviest and slowest first, and the lightest, and presumably the fastest, is placed last:

	Diam. of Cylinders. Inches.	Driv. ers. Lbs.	Wt.on D'vers. Press.	Steam Area. Sq. ft.	Grate Area. Sq. ft.	Heat- ing Sur- face. Sq. ft.	Ratio Grate Area to Cyl. Volume.	Ratio Heat- ing Sur- face to Grate area.
Union Ry. of Pittsburg...	23x32	54	203,000	200	33.5	3,322	2.18	99
Penna. Rd., Class H-4..	22x28	..	173,400	180	29.7	2,470	2.41	83
Gt. Nor. 10-whl. pass..	20x30	63	129,500	210	35.4	2,677	3.25	75
Nor. Pac. 10-whl. pass..	20x26	69	112,000	200	30.8	2,485	3.26	81
C. & N. W. 8-whl. pass..	19x24	75	79,000	190	26.8	1,910	3.40	71

Please note the increase in the ratio of the grate area to the cylinder volume as we go from the heavy freight engine to the passenger engines running in mountainous districts, and finally to the eight-wheeled passenger engine running in a locality where the grades are easier and the average speed consequently higher. Please note, also, the decrease in the ratios between heating surface and grate area as we go from heavy to lighter engines. Every foot of heating surface that could be obtained within the limits of weight, doubtless, was obtained in each case, but in the passenger engines the ratio could not be made as large as in the freight. In the mammoth freight engines large heating surfaces are obtainable, but large grates are not an actual necessity and the difficulty in firing them properly tends to keep them even smaller than Mr. Higginson's ratio would require; on the other hand, in high-speed passenger engines the greater consumption of steam per unit of cylinder volume per minute requires a larger grate than given by his ratio, even if a corresponding increase in heating surface is not possible within the weight available. I have an intimate knowledge of the performance of the engine that is last in the above table, and I have no hesitation in saying that if the ratio between grate area and cyl-

inder volume in that engine was 2.4, instead of the 3.4 that it is, the engine would be a flat failure.

If another illustration is necessary to prove my position, I would state that on a western road ten 18 by 24-inch passenger engines with a grate area of exactly 2.4 times the cylinder volume have proved such poor steamers that new boilers with larger grates are being put in them. The heating surface was sufficient, but the grate area was not.

I wish to say in conclusion that in the desire to see large heating surfaces and moderate-size grates my views coincide with those of Mr. Higginson, and I disagree with him only in that I don't believe in his fixed ratio between grate areas and cylinder volumes.

W. H. MARSHALL.

Asst. Supt. Motive Power, Chicago & Northwestern Ry. Chicago, Nov. 2, 1893.

DANGEROUS LOCOMOTIVE CABS.

Editor "American Engineer:"

It is a lamentable fact that appalling disasters seem to be needed as final arguments to prove the menace to safety which lies in a continued disregard of palpable elements of danger.

The rear-end horror at Revere, Mass., on the evening of Aug. 26, 1871, on the Eastern Railroad of Massachusetts marked the degree of impressiveness required to force the adoption of the Westinghouse brake—a God-sent apparatus, which had already demonstrated its practicability and safety-enhancing capacity, and had long before been taken up by roads where congestion of traffic was an unknown quantity.

The finding some years ago on a New York ferryboat of a pilot dead at the wheel made it obligatory for the ferry companies to have a second person, usually a deck-hand, in the pilot house during each trip, an eminently proper measure. A close parallel in the finding of a slaughtered unfortunate on the footboard of a Philadelphia & Reading locomotive, perhaps three years ago, has not, however, so far as I have seen, resulted in means to set aside the evident risk attendant on such isolation of engineers from firemen as is due to the employment of that type of engine known variously as "Hog," "Dirt Burner," "Mother Hubbard," etc., and more properly called the "Wootten" engine.

That an engineman can be stricken down and the fireman remain in ignorance of it for a dangerously long time cannot in honesty be denied by anyone who has covered a division on the firing deck of one of these engines during a dark and stormy night. In the comparatively inexpensive quality of fuel permitted by such grate surface as these engines have, there is no doubt in some localities a large advantage, but improvements are not always necessarily unalloyed blessings or successes. The main object intended may be accomplished, but when in so doing it seriously lessens the value of an important factor of safety, it can hardly be said to be a complete advancement.

In the engines so common twenty-five years back this source of danger, due to separation of crew, was lacking, and while it is fully recognized as having been only a happy chance that their cabs were designed on lines of greater sociability, it was still a chance, which furnished in a measure a dual control of the engine, and supplied a deficiency in that direction dangerously lacking in many of the modern monsters. In line with some of the first departures from that type of engine, which allowed mutual companionship and aid, was that style, rather undignifiedly referred to on the Erie road, in my hearing, as "Wilder's stem winders," where the firing was done wholly outside of the cab, though at a but slightly increased distance between the two men on the engine. Then, following a dangerous precedent of many years before, came the Wootten firebox engine, with its 15 feet of separation of engineman and fireman, and with it the introduction of a danger to be proven sooner or later by some convincing truth, other, it is hoped, rather than a catastrophe, not traceable to another cause.

Perhaps the latest tragic proof of the lurking presence of this threat against safety, which has just occurred on another prominent nearby road with this class of engine, will arouse sufficient attention to result in the minimizing, if not abolition, of this unnecessary risk.

Large bodies are usually richer in inertia than smaller ones, hence a possible explanation of why a safeguard against this particular danger was quickly put into use by ferry companies and apparently ignored by railroad companies. The tortoise has been guarded; the hare left unprotected.

WM. F. MONAGHAN, M. E.

Member A. S. M. E.

New York, November 21, 1893.

STARTING VALVE LOCKING DEVICE FOR COMPOUND LOCOMOTIVES, PHILADELPHIA & READING RY.

The device shown in the accompanying illustrations is presented through the courtesy of Messrs. L. B. Paxon, Superintendent of Motive Power, and Mr. E. E. Davis, Assistant Superintendent of Motive Power, of the Philadelphia & Reading Railway. It was designed by Mr. H. H. Vaughan, Mechanical Engineer of the road. This road has a number of compound locomotives of the Vanclain type, and the purpose was to prevent the enginemen from working high-pressure steam in the low-pressure cylinders, except when the reverse lever is in full gear. This is accomplished by a simple arrangement which is applicable to any class of compounds on the road. It does not require the use of live steam in full gear unless the engineman moves a lever to operate the starting valve, and it automatically closes the valve as the reverse lever is moved out of full gear. It will be remembered that the device used on these compounds to increase the cylinder power in starting and in pulling over heavy grades consists of a by-pass connecting the two ends of the high-pressure cylinder. This allows steam to pass from the steam to the

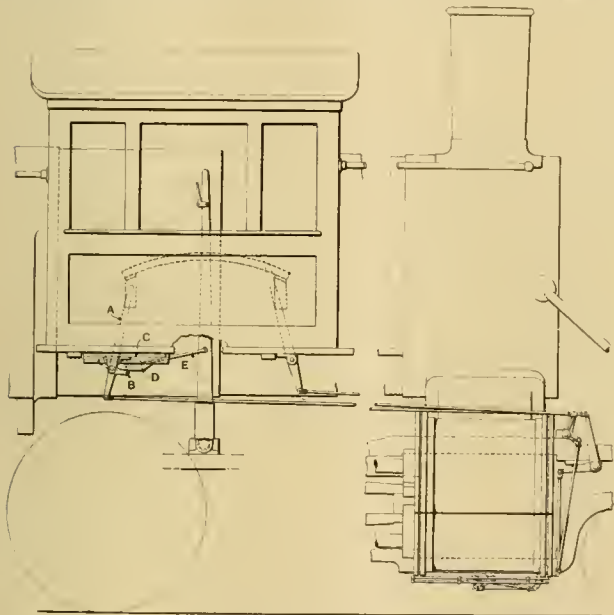

Starting Valve Locking Device for Compound Locomotives, Philadelphia & Reading Ry.

exhaust side of the high pressure piston and from there into the steam side of the low-pressure cylinder. The object of the attachment is to prevent improper use of the valve controlling this passage.

The arrangement of starting valve and cylinder cocks is shown in the drawing. The cylinder cocks are the regular ones in use on the road, and are screwed into bosses at each end of the high-pressure cylinder. The starting valve is a straightway plug cock fitted with a handle which, when shut, is in the position shown in the elevation, and is connected by a 1-inch pipe to the high-pressure steam ports. The cylinder cocks are actuated by the usual mechanism and are entirely separate from the valve, although the bell crank moving them works on the same pin as that for the valve, simply as a matter of convenience. The valve is worked by a lever, A, placed, in this case, behind the reverse lever. This lever has a short arm, to which a roller, B, is pinned, and is fulcrumed in the casting C, bolted to the running board. In this casting a slide, D, with inclined ends, is guided, which is connected by a rod, E, to a stud placed in the reverse lever at such a point that it travels 16 inches as the lever passes from "corner to corner." In the position shown the lever, A, is in the closed position and cannot be open on account of the roller, B, engaging with the slide, D. When the reverse lever is moved into full gear in either direction the slide travels far enough

to clear the roller, and the combining valve can then be opened. If the reverse lever is then hooked up, the inclined end of the slide engages with the roller and forces the lever, A, back to the closed position. The slide is of such a length that the starting valve can be opened for about two notches in each end of the quadrant.

The device is well designed, and the general application of such a check upon the use of high-pressure steam would compel justice to compound locomotives and result in improved performance sheets. It is clear that for economical working this valve should be kept shut, except when actually needed to start the train or to prevent it from stalling. We are glad to be able to direct attention to improved methods of operating compound locomotives. This type, we believe, has suffered in many cases on account of lack of appreciation of the importance of observing the necessary precautions in using the compound principle at its best advantage.

WATER STATIONS FOR RAPID DISCHARGE.

Mr. T. W. Snow, in a paper before the Western Society of Engineers on locomotive water supply stations, gave the following figures for rapidity of delivery with different lengths of pipe and sizes of cranes:

In designing a water station for one of our large railways recently the problem given was to obtain 4,000 gallons per minute through a distance of 350 feet. The mean head of water supply was made 38 feet; from this must be deducted 12 feet for height of crane, leaving net head of 26 feet. In computing this flow an allowance of 10 per cent. was deducted for the friction of the water column. In figuring this discharge Mr. E. E. Johnson's curve of discharge was used, and, comparing actual result with theory, we fell short only 400 gallons per minute. This is pretty fair for practice, for, considering that all table-makers are careful to state that only "straight, smooth pipes were used" (they want no "curves"), we laymen have to make due allowance for the cast pipe of commerce, which usually is anything but smooth, and not always straight. The bell and spigot connection causes considerable disturbance to the

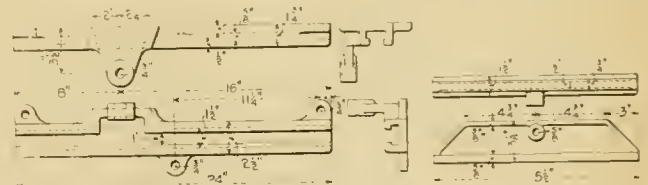

flow, setting up what in electrical parlance would be termed Foucault currents.

In the station just referred to the supply pipe was 12 inches in diameter and the crane 10 inches; the distance as stated was 350 feet, and the discharge was 1,600 gallons in 25 seconds, or at the rate of 3,840 gallons a minute. Under the same conditions, with 1,000 feet of 12-inch pipe and a similar crane, this flow was reduced to 3,000 per minute, due solely to friction. Comparing this again with Johnson's table, above referred to, we find that we should have obtained 3,300 gallons.

Again, on a recent test with an 8-inch crane and 1,300 feet of 8-inch pipe under 125 pounds pressure the rate of delivery was 3,500 gallons per minute. Consulting the same table we have as the theoretical output 3,535 gallons. That pipe line is too smooth and straight, and I have written for a verification and new time test.

The objections to the water crane are that it is an expensive adjunct to a tank (most of the devices of this kind not being adapted to city water mains direct), and they are time consumers, taking many minutes more than the direct method of using tank fixtures. This latter objection more nearly applies to the old-time sizes of crane, viz.: 4, 6 and 8 inch, as the foregoing results will show.

An old coal mine near Portsmouth, Rhode Island, is to be opened with a view of selling the coal for fuel in the form of briquettes. "The Engineering and Mining Journal" says that the quality of the coal formerly mined there was not of the best, and notes an old jest to the effect that it was the only absolutely fireproof material known. The opening of a coal mine in that section is interesting, no matter what the quality.

(Established 1832)

AMERICAN ENGINEER

CAR BUILDER AND RAILROAD JOURNAL.

29TH YEAR.

67TH YEAR.

PUBLISHED MONTHLY

BY

R. M. VAN ARSDALE,

MORSE BUILDING.....NEW YORK

G. M. BASFORD, Editor.

DECEMBER, 1898.

Subscription.—\$2.00 a year for the United States and Canada; \$2.50 a year to Foreign Countries embraced in the Universal Postal Union. Remit by Express Money Order, Draft or Post-Office Order. Subscriptions for this paper will be received and copies kept for sale by the Post Office News Co., 217 Dearborn Street, Chicago, Ill.

EDITORIAL ANNOUNCEMENTS.

Advertisements.—Nothing will be inserted in this journal for pay, EXCEPT IN THE ADVERTISING PAGES. The reading pages will contain only such matter as we consider of interest to our readers.

Special Notice.—As the AMERICAN ENGINEER, CAR BUILDER AND RAILROAD JOURNAL is printed and ready for mailing on the last day of the month, correspondence, advertisements, etc., intended for insertion must be received not later than the 20th day of each month.

Contributions.—Articles relating to railway rolling stock construction and management and kindred topics, by those who are practically acquainted with these subjects, are specially desired. Also early notices of official changes, and additions of new equipment for the road or the shop, by purchase or construction.

To Subscribers.—The AMERICAN ENGINEER, CAR BUILDER AND RAILROAD JOURNAL is mailed regularly to every subscriber each month. Any subscriber who fails to receive his paper ought at once to notify the postmaster at the office of delivery, and in case the paper is not then obtained this office should be notified, so that the missing paper may be supplied. When a subscriber changes his address he ought to notify this office at once, so that the paper may be sent to the proper destination.

The paper may be obtained and subscriptions for it sent to the following agencies: Chicago, Post Office News Co., 217 Dearborn Street. London, Eng., Sampson Low, Marston & Co., Limited St. Dunstan's House, Fetter Lane, E. C.

The Directory of Officials of the Railroads of the United States and Canada, which has been printed and regularly revised in our paper since the publication of the first issue of the National Car Builder, has been consolidated with the Pocket List of Railroad Officials, published quarterly by The Railway Equipment & Publication Co., 24 Park Place, New York. This Pocket List is exceedingly complete. It is revised with the greatest care, and because of its convenient form, it is very handy for the satchel and the desk. The consolidation is a fitting one, and our friends who have found this feature of the "Car Builder" advantageous need not miss our directory, because they have a better one. We have published our directory for so many years that it is hard to let it go, but the change is believed to be in the interest of improvement, and it is a benefit to our readers.

In consideration of the large proportion of the expenditure for equipment and maintenance in the mechanical, bridge and way departments of railroads, and on account of the difficulties in the way of keeping proper checks upon their operation, it is very important that the administration should be intelligent and businesslike. As a rule, the control of these departments is intrusted to general officers, who, while admirably competent and efficient as to methods of train operation, are not

equally qualified to manage and decide engineering matters. It is becoming more evident every year that the final decisions should be intrusted to officers who are either thoroughly qualified by experience to decide them, or are possessed of the commercial faculties which will enable them to settle them on what may be called a business basis. Several examples have recently forced the conclusion that this subject needs attention. Either the engineering officers should be general managers of their departments, which all good ones are qualified to be, or they should be responsible to those who are competent to direct their actions in large matters, and who are able to give important subjects the attention they require. It would give point to these remarks to name specific cases. This will not be done here, but it is not difficult for railroad managements to find out whether it applies to them. The roads are rare upon which in engineering management, and particularly as regards the mechanical departments, vast improvements may not be made.

The breakage of piston rods, which was the subject of several articles in our last two issues, has called forth a vigorous response from a correspondent, who gives reasons for several failures coming to his attention that are absurd enough to merit notice. He cites a case of a class of engine on a large road (where the officers ought to know better) in which a desired increase of power was obtained by increasing the boiler pressure from 160 to 180 pounds without any changes except in the boilers. The same cylinders, piston rods and crossheads were used, and the piston rods gave trouble at the start. If the parts were large enough for the previous condition, which, however, is somewhat doubtful, they proved at once to be too small for their increased duties. But this was not the worst that our correspondent had to say. He also told of a road, and it must be a small one, upon which the crosshead ends of piston rods were not enlarged in the natural course of increasing the dimensions of engines, merely because the Master Mechanic objected to carrying another size of reamer in the tool room stock. It is to be hoped that all of his piston rods broke until this idea of economy was overcome. These cases are well vouched for, and no further comment is necessary, except to call attention to the treatment of the subject of fiber stress in the articles that we have printed from the pen of Mr. Francis J. Cole.

INCREASED PISTON STROKE.

The present tendency toward increasing the stroke of locomotives raises the question in many minds as to the value of the change and the extent to which it is advisable to go in this direction. A correspondent asks us whether it is desirable to adopt 26 inches as common practice and whether it is advisable or desirable to exceed this.

Mr. G. R. Henderson's excellent presentation of the subject of cylinder capacity in this issue is specially valuable at this time and it will answer some of the queries that have been raised.

There are several advantages to be gained by increasing stroke, some of which are in the nature of steam engineering and the others are purely mechanical. Among the former are: Reduced clearances, reduced steam condensing surface and less initial condensation of the steam. On the other hand, the increased stroke causes higher piston speeds, but the effect of this is probably much more than offset by the gain in connection with the clearance and condensing surfaces.

Starting power may be increased by lengthening the stroke or by decreasing the size of driving wheel. This also applies to pulling power when running and influences the ability to climb grades or to pull heavy trains, providing, of course, that the boiler capacity is sufficient, and lengthening stroke within proper limits will be advantageous for fast and heavy stock, meat and tea trains.

Large cylinder power may be obtained by increasing diameter or lengthening stroke. The former method is limited in very

large engines by the clearance width of the road, and when it is necessary to provide large cylinders the diameter is kept down for this and another important reason. The stresses from the steam pressure on the running gear are higher with large cylinder diameters. By selecting a cylinder with smaller diameter and longer stroke the stresses on the piston, piston rod, main and side rods, crank pins, axles and driving boxes are reduced, these parts may be made lighter and the weight may be put into the boiler, where it will do the greatest amount of good.

The limit to the increase of stroke is not to be stated in figures, but in the relations between the dimensions of diameter of cylinders and wheels, considering the work the engine is to do. Thirty-four inches is the maximum stroke thus far used in freight engines, but it is not expected that this will be reached in passenger engines on account of the piston speed. Very long stroke is satisfactory in slow service, and while 24 inches will doubtless be exceeded in passenger engines and 26 and even 28 inches will be used in some cases, the necessity of keeping the piston speed down will tend to prevent the use of strokes longer than these for this service.

THE PRESENT STATUS OF THE COMPOUND LOCOMOTIVE.

There must be good reasons for the wide differences of opinion of well informed railroad officers with regard to the value of the compound locomotive as a type, and because of the attitude of several of these, which has led them to issue instructions to their subordinates "that no more compounds are to be bought or built," we shall review what appears to be the most important of them.

Many little difficulties, common to all mechanical development, have been found in compounds, and most of them overcome, but the chief reason for the failure of the type to become generally popular is that in the earlier days the cylinder power was insufficient and the compound was not a success as a factor in operation. The question of first importance in designing a compound is to give it the ability to handle heavy trains. When the type reaches the stage of being satisfactory from an operating standpoint it is almost certain to be satisfactory as to economy. The two go hand in hand. The present tendency in increasing cylinder power is in the right direction, and the result is likely to be a change of conditions that will favor the compound and the type will probably occupy a very prominent place in future practice.

Under present conditions weakness in a locomotive means wastefulness in operation, and as an example of the effect of light trains on the coal records, the following figures are quoted from the results of a recent experiment on a prominent Western road. They are taken from the performance of heavy and light trains on the same division, and give the average of a group of several men, in order to eliminate the effect of different methods of handling:

Average Tons in Train for Month.	Pounds Coal per 100 Ton-Miles for Month.
842	16.2
716	17.8
543	19.4
482	22.8

It must be borne in mind, however, that speed must be considered, because light trains are usually fast ones, and some of the differences in this table are due to this fact. The higher speeds in this case probably account for less than half the difference in the coal burned. In this case a reduction of about 40 per cent. in the weight of the train caused an increase of about 40 per cent. in the amount of fuel burned per 100 ton-miles.

Many comparative tests have been made between simples and compounds, and an illustration of the fact that the importance of cylinder power is not appreciated is seen in the case of a test made recently between a compound designed for more than 200 pounds steam pressure, while the simple engine was working with but 180 pounds. In an attempt to operate the two under similar conditions the pressure of the compound

was reduced to 180 pounds, to correspond with the simple engine. The idea was correct, as the two types ought to be compared on the same basis, but the fact that the compound had been designed for higher pressure was overlooked. The effect of the change was to rob the compound of cylinder power, and the result was a failure of the type to make the favorable showing that was expected. The deficiency in power was a serious handicap, which, in this case, the advantages of compounding were unable to overcome. It has been customary to insist that the boiler capacities of simple and compound engines that are tested in comparison should be equal, and the really vital factor of equal cylinder capacity has sometimes, even often, been overlooked.

Troubles were had with some of the earlier forms of intercepting valves, and a number of minor difficulties have been found in connection with lubrication and the use of relief valves, but most of these have been overcome, and the rest will not long prove difficult. The compound has also been handicapped because it has not been as handy as a simple engine in switching and in backing out of sidings. Another factor is that enginemen have not been sufficiently familiar with the type to give it a fair chance. This is proven by the necessity for providing a check upon the incorrect use of the starting valve as worked out on the Philadelphia & Reading and illustrated elsewhere in this issue. The draft on the fire, being lighter than in a simple engine, requires lighter firing and the fire must be kept thinner. When all the enginemen who are called upon to handle compounds have sufficient experience to understand them thoroughly they are bound to give better results. There is an additional feature that operates against the compound in the fact that the margin between a proper load and an overload seems to be smaller than in the other type. The effect of this was more serious when cylinder powers were less. Whatever the reason for this, it tends to show the importance of adjusting the tonnage rating with considerable care. It is to be expected that a new type will spend more time in the shop than an old one, but when the compound has had the study and development that have been devoted to the simple engine, there should be no differences in the cost of repairs. The weak points will be discovered and the designs improved. At least three prominent superintendents of motive power, having had extended experiences with various designs of compounds, are even now prepared to show that they are able to maintain some of their compounds as cheaply as corresponding simple engines.

The reason why the compound will be used is that when given work to which it is adapted it will consume less fuel and water for the same tonnage handled by a simple engine. The fuel economy is the chief item, but when bad water must be used the compound has the advantage of using as little of it as possible. If the compound will save 10 per cent. in fuel, and do it day after day, without undue attention, it will offer one of the cheapest ways for a railroad to save money; and when the type is more thoroughly understood it will be accepted on this basis as a constant source of economy. Fifteen per cent. will be obtained in many cases, but 10 per cent. is stated as a conservative proportion. The reason for the economical operation is in the smaller range of temperatures being the expansion. This has important influences over the condensation and re-evaporation of steam in the cylinders, and permits more work to be done without using more steam.

Many want to know when they ought to use compounds and when simples. We should say that whenever the average work done by a simple engine is so great as to necessitate running at an uneconomical point of cut-off, or over $\frac{1}{2}$ stroke or $\frac{1}{2}$ stroke, the compound may be expected to do the same work with a saving in fuel. When the speed is high, and the cut-off shortens, the compound has less opportunity to save fuel. This applies to both freight and passenger service and to the average work of the engine. When most of the work of a division is light and the full stroke capacity of the engine is required only a few times in every trip, while the rest is comparatively easy work and the time fast, the compound would be at a dis-

advantage. Of course, operating conditions must be considered, and pusher engines should be used where conditions favor them, but after operating questions have been disposed of the question of the compound may be summed up as stated. With light loads there is nothing to be gained by compounding, and if the experience of English railroads in compounding is having any influence on opinion in this country, it is important that those influenced should study the differences in the conditions in the two countries.

NOTES.

The "Penacock," a new Government tugboat, recently launched at the Brooklyn Navy Yard, is of steel and 75 feet long. The work upon her has all been done with pneumatic tools.

A total number of 1,538,764 passengers were carried by the surface and elevated railroads of Chicago on October 19, the occasion of the Peace Jubilee parade and the visit of President McKinley.

A train on the Erie on October 24 ran 20 miles with the engineer dead from striking his head against some obstruction. The engine was of the Wootten type, with the fireman and engineer separated by half the length of the boiler. The fireman's attention was attracted by unusual speed, and he soon stopped the train.

The danger from the narrow range of water level in water tube marine boilers receives emphasis from the bursting of several tubes on the U. S. torpedo boat "Davis" while running her official trial at Astoria, Oregon, recently. Three men were killed instantly and four more died after terrible suffering. The explanation offered is that "low water" occurred through a failure of the automatic water regulator.

"Bilgram's Diagram and the Solution of Problems Involving Lead" is the subject of a brief article by Mr. Merrill Van G. Smith, in the Journal of the Franklin Institute for November. The object is to show that by a simple construction not only an approximate but an exact solution of the angular advance, lap and eccentricity may be found when the point of cut off, lead and port of opening are given.

In commenting upon the possibilities in the development of locomotives and railroad transportation, "Engineering News" shows that the "largest locomotive in the world," that we illustrated last month, is probably able to pull a train carrying 3,375 tons of grain, or a fair-sized cargo for a Lake steamer. This engine has a load of 26,000 pounds on each driving wheel, which exceeds all previous practice. The big engine is here to stay, and bridge men must get their structures strong enough for it.

A convenient method for unloading logs from special logging cars has been introduced on the Chicago & Northwestern by Mr. C. A. Schroyer, Superintendent of the Car Department. Short flat cars are used for the logging business, and skids made of old rails are placed at intervals of about six feet along the floor. The bottom logs are held in place by latches released by chains laid on the floor beside the skids. In unloading the car a man releases the latches on the side opposite to that at which he stands. He then raises the side of the car about ten inches by means of jacks and the load rolls off bodily.

The cost of electric power was the subject of an elaborate paper by Mr. R. W. Conant, read before the Boston meeting of the American Street Railway Association. In studying the cost of operation of 44 power stations in different cities he found that the cost of power alone for the past year was \$1,825,000, and if the power had been produced by all at the rate of the most economical plant, a saving of \$443,300 would have been made. The conditions were not equally favorable

in all cases, but this statement shows the importance of good designing and care in management.

Long locomotive runs are made on the Sunset Limited of the Southern Pacific. The distance between Algiers, La., and Oakland, Cal., 2,484 miles, is made by nine engines. The division points taken from Oakland are: Bakersfield, 314 miles; Los Angeles, 168 miles; Yuma, 250 miles; Tucson, 251 miles; El Paso, 312 miles; Sanderson, 316 miles; San Antonio, 308 miles; Houston, 209 miles, and Algiers, 362 miles. A continuous run of 119 miles without a stop is made on the division between Los Angeles and Yuma, and a helper is used on Tehachapi Mountain, between Bakersville and Los Angeles. The crews are changed at several points intermediate between those stated.

The Chief of the Bureau of Ordnance U. S. Navy, Capt. O'Neill, says: "Experience has shown that guns in turrets operated by electric power can be laid upon and more accurately made to follow a moving target than when operated by steam, hydraulic or pneumatic power. There are no water pipes to freeze, no steam pipes to burst, and no delay in obtaining a full working pressure, and no troublesome or noisy exhaust pipes to deal with. A burned-out fuse can be replaced quickly or a broken wire repaired, and as the wires can be led below the armored deck, there is little liability of the latter becoming necessary."

In repairing a locomotive firebox much time and inconvenience may be saved by turning the boiler over to bring the mud ring on top, and this is the practice of several builders in new construction. The advantage is that more men may work on the boiler without getting in each other's way, and by comparing the ordinary method of working on the inside of a firebox or on the mud ring, when the boiler is in its natural position with the other method, the awkwardness of the former is apparent. The cylinders must, of course, be removed, but instead of being a disadvantage this is often necessary any way, and it is desirable that the connection between the saddles and the smoke box should occasionally be renewed. The cost of the additional work required may be placed at about \$20, and at the Chicago & Northwestern shops, where the boilers are inverted, the saving by reason of the convenience of the work is estimated at between \$40 and \$50 on each engine. The front end of the shell, after the cylinders are out of the way, rests on wooden blocking, and the back end is supported by a trunnion in a plate that is bolted to the fire door hole, the trunnion being carried on a frame made of an arch of an old 8-inch I-beam on a base of planks.

A simple formula for the capacity of fans of the centrifugal type that is said to be remarkably accurate has recently been devised by Prof. R. C. Carpenter, of Cornell University. From a large number of experiments, it was found that the number of cubic feet of air discharged in one revolution of the fan was equal to the cube of the diameter of the fan expressed in feet, multiplied by the constant 0.5, if there was a free delivery, and 0.4 if the pressure was about that found in ordinary blower practice; or equal to the pressure of one and one-half inches of water.—"Engineering Record."

PNEUMATIC RIVETING BY PORTABLE MACHINES.

The Chicago Ship Building Company has been using pneumatic riveters in its ship yards for the past three years, and Mr. W. I. Babeock, manager of the company, gave some interesting statements in regard to the results in a paper presented at the recent meeting of the Society of Naval Architects and Marine Engineers.

As a result of this experience this concern is now able to drive every rivet in a ship by power machines, operated by unskilled labor, and in the last ship built by them over 250,000 out of a total of 340,000 rivets were so driven, the lack of

sufficient air capacity being the reason for not driving them all in that way.

In beginning the work a horizontal stationary steam riveter was used, having a 5-foot reach, and with it 1,800 rivets were driven in ten hours, costing one-half cent each, the work in this case being brought to the machine, saving about 2½ cents over hand work. Compressed air then recommends itself for portable machines because it would not freeze, and pneumatic power was required at the works for working hammers, calking machines and reamers. Two years ago a 72-inch and a 45-inch bow machine were put in. The first weighed 2,500 pounds and the second 1,700 pounds, but they were awkward in handling and soon gave place to pneumatic hammers used in connection with a pneumatic holder on. The next step was to combine the hammer with the holder on by a light frame in the shape of a horseshoe. The frame being of iron pipe, and so light that one with a reach of 9 inches weighed 83 pounds, another with 52-inch reach weighed 160 pounds, and with a 70-inch reach 220 pounds. The result of this experiment was to secure an improvement over hand work, as the rivets were driven hotter than by hand. Convenient methods of holding the machines and transporting them were provided. In deck work, where a pneumatic holder on is used from underneath, three men and a boy, for heating the rivets, drive from 800 to 1,000 in a day.

In concluding the paper Mr. Babcock says that "The unanimous opinion of the hull inspectors, who have been in duty in our yard for two years and more, is that the rivets are first class in every respect, and make far better and tighter work than those driven by hand. As for the cost, I will say that, adding cost of air, repairs, etc., the saving is from 1 to 2 cents per rivet over piece work prices for hand riveting, depending upon the location in the ship, and averaging about 1¼ cents. In an ordinary lake steamer of 4,000 tons the saving is from \$4,000 to \$5,000 over hand work.

"In conclusion I want to say that the quality of the work done by portable pneumatic riveters in ship building is such that the various classification societies cannot ignore it, and before very long will doubtless recommend, if not require, that all rivets in at least the principal portions of the ship be driven by power."

This experience corroborates that illustrated on page 378 of our November issue, and, if we are correctly informed, the machines used by the Chicago Ship Building Company were furnished by the Chicago Pneumatic Tool Company.

WATER TUBE BOILERS MEET AN EMERGENCY IN THE NAVY.

The Babcock & Wilcox Company received special mention in the annual report of Commodore Melville, Chief of the Bureau of Steam Engineering, U. S. N., for their work in the emergency of preparing vessels for use in the recent war, his commendation being expressed as follows: "The work immediately necessary on the breaking out of the war was not so much extensive repairs to ships in commission as the fitting out of every available ship in ordinary so as to get some service out of each one in the possible crisis. The old single turret monitors were susceptible of fair use as harbor defense vessels if they could quickly be made seaworthy, and one of the most notable engineering feats was in connection with this work. This consisted in the actual cutting out of the old and worn-out boilers of the monitors Manhattan, Mahopac and Canonicus, at League Island, and erecting new boilers in their places without cutting the decks, and all within the space of thirty days. The boilers as cut up were passed out through the smoke pipe opening and the new sections put down the same way, the results proving most satisfactory. This work was done by the Babcock & Wilcox Company, under contract, and this firm deserves great credit for the expedition with which the work was done. It was well known that these vessels could not be used unless new boilers were fitted, and before war was declared the Bureau had ascertained that the firm mentioned was the only one which could do the work in less than three months. Arrangements for beginning the work promptly had been made, and in less than five hours after the new boilers were authorized by the Department the work of building them was commenced. It is a source of satisfaction that the performance of these vessels with the new boilers exceeded that when the vessels were first built."

THE HARRIS COMPOUND DIRECT AIR PRESSURE PUMP.

A new system of pumping by compressed air is being introduced by the Pneumatic Engineering Company, 100 Broadway, New York, that appears to be a great improvement over methods previously used in the direct application of air pressure to the pumping of water. Air lift pumps are not new, but this system employs an arrangement which, while avoiding complications of floats and valves, utilizes the pressure of the air directly upon the water in a new way, in which what may be called the exhaust air is used to assist the compressor instead of being wasted at high pressure.

The engraving shows a simple application of a pump to a single source and a single lift. The pump has a suction and discharge pipe and two pump tanks, which are alternately opened to the suction and discharge. The air compressor is connected to the tops of the tanks by air pipes leading to an automatic valve or switch near the compressor. With the switch in the position shown the compressor is forcing air

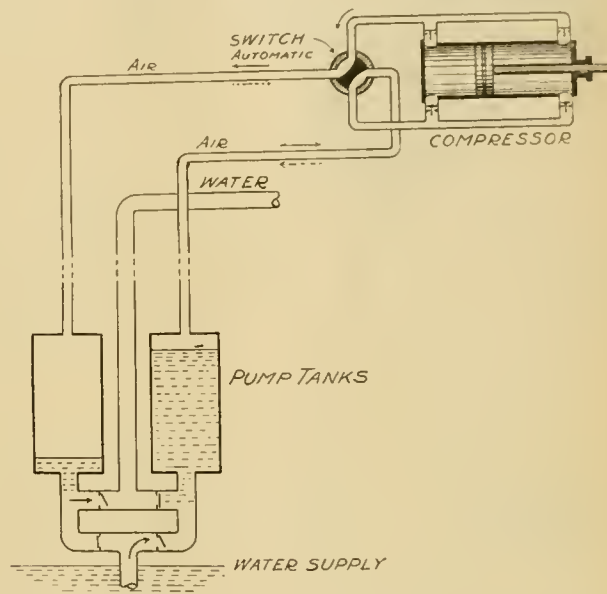

The Harris Direct Air Pressure Pump.

down through the pipe at the left, driving the water from the left-hand cylinder into the discharge pipe, the suction side of the compressor is connected to the right-hand air pipe and the right-hand tank is filled from the water supply. When this tank is empty the switch automatically changes its position and reverses the pipe connections, forcing the water from the right-hand tank into the discharge. The automatic operation of the switch may be effected in one of several ways, one of which is by mechanism that will change its position after a certain number of strokes of the pump, which is determined by experiment. In case more air is pumped than is needed the surplus will escape through the water discharge, and in case too little air is pumped, some of the water will remain in the pump tank, reducing the output of the apparatus, but these matters may be readily adjusted by the man in charge of the compressor.

With deep pumping the lift may be divided into two or more stages, but it is stated that a compound compressor may be used against a head of 200 feet or more. One of the peculiar advantages urged for the system is that one compressor may be used for a large number of wells, which may be widely separated from each other and from the compressor. The system is also adapted for fire protection.

The system has fewer mechanical complications than any pump used, except that known as the "air lift." It is claimed that in a properly proportioned system the losses outside of the compressor, including the friction in the air and water pipes and expansion in the air pipes, will not exceed 20 per cent. The system was developed and patented by Elmo G. Harris, C. E., Professor of Civil Engineering in the School of Mines of the University of Missouri.

PNEUMATIC CHAIN HOIST, WITH REVERSIBLE MOTOR—
THE CHICAGO PNEUMATIC TOOL CO.

The chain hoist has long been one of the favorite devices for use about shops and machinery. Its special advantages are that it is powerful and holds the load at any height, it is light and easily attached, which, together with the fact that it may be operated where there is comparatively little head room, explains its popularity and extensive use. The only disadvantage of the chain hoist when operated by hand is its slowness, but this is overcome by the attachment of an air motor, such as the one shown in the accompanying engraving, and the arrangement has certain advantages over all other forms of air lifts. There is no movement of the load caused by leakage of a piston or jumping of a part of the load when another part is suddenly removed, such as occurs with many cylinder hoists, and the height to which the load is raised may be nicely adjusted by a chain hoist, which is a convenience in putting axles or other pieces into lathes.

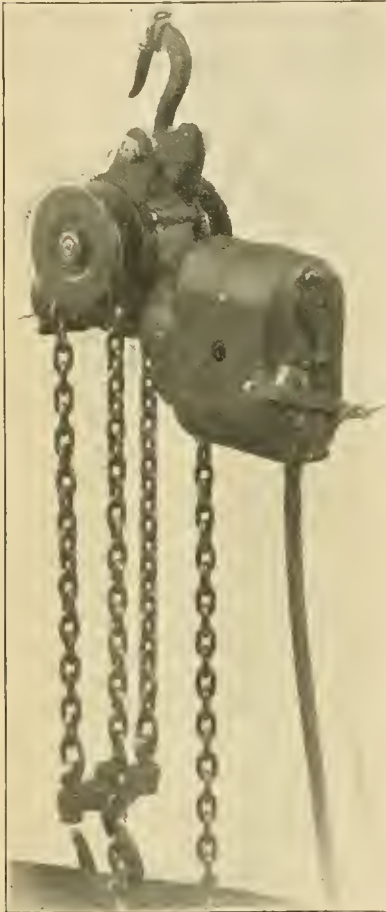

Pneumatic Chain Hoist.
CHICAGO PNEUMATIC TOOL CO.

The hoist shown is manufactured and sold by the Chicago Pneumatic Tool Co. It is operated by a Whitelaw reversible air motor, and without the chain it weighs 40 pounds, and this size will lift 800 pounds. It is made in two sizes, the larger one having about double the capacity of

the one illustrated. The motor is intended to work at a pressure of about 80 pounds per square inch, and the size illustrated consumes only 10 cubic feet of free air per minute. The motor may be reversed at any time, giving complete control of the load. The throttle is governed by the bar attached to the rear of the motor, and ropes hanging from holes in the bar are fitted with handles for operating the hoist. The ingenious construction of the hoist is clearly seen in the engraving.

THE AIR-BRAKE SITUATION.

The Westinghouse Air-Brake Company authorizes the following statement in regard to the New York and Boyden Companies:

"The purchase by the Westinghouse Air-Brake Company of the patents and business of the Boyden Brake Company is the final conclusion of a long and interesting litigation relating to air-brakes.

"The course of these suits has been followed with interest by railroad men, because, to a considerable extent, they involved the right of the Westinghouse people to the sole manufacture of what is known as the "Quick Action" brake. By the purchase of the Boyden inventions, which the Supreme Court said were highly meritorious, the Westinghouse company still claim to control the situation, although this is contested in the United

States courts by the New York Air-Brake Company. The Westinghouse company have been successful in compelling the New York Company to cease making three different forms of brakes, and they claim that a fourth one which they are now putting on the market is also an infringement of their patents. This question will be finally determined by the Court of Appeals, probably in November or December, the opinion of the lower court having been favorable to the New York company. Should the decision be favorable to Westinghouse, then the New York company will once more be enjoined and prevented from making their present style of brake.

"In addition to this particular suit, it appears that the Westinghouse people have brought three other suits against the New York company, and it would, therefore, look as if litigation between these two concerns was to be, if anything, more protracted than that between the Boyden and Westinghouse companies."

BREAKAGE OF M. C. B. COUPLERS.

Mr. P. H. Peck, Master Mechanic of the Chicago & Western Indiana, in a paper read before the Western Railway Club, makes the following observations with regard to the breakage of M. C. B. couplers:

I find, from the records kept in my office for the past six and one-half years, that as the number of M. C. B. bars handled increased, the percentage of broken bars and of broken knuckles decreased, as shown by the following table:

Year.	Per cent. M. C. B. bars.	No. cars. to 1 bar broken.	No. cars. to knuckles broken.
1892.....	8 per cent.	377	2,476
1893.....	15 per cent.	385	1,681
1894.....	20 per cent.	424	1,609
1895.....	28 per cent.	620	1,663
1896.....	42 per cent.	996	2,345
1897.....	48 per cent.	1,240	2,573
1898.....	59 per cent.	1,872	3,047

A large proportion of the breakage of knuckles occurs when an M. C. B. coupler is coupled with a link and pin bar, such breakages being most likely to occur in heavy trains. In some cases the coupling is made by the pin being placed through only the top hole of the knuckle and into the link; this either breaks the top lug off or breaks out the pin hole; in other cases the knuckles may be broken when two cars strike together and both knuckles are closed. Very few M. C. B. bars are broken when two of these bars are coupled together. Included in our own equipment we have 88 cars and 22 locomotives equipped with M. C. B. couplers; 32 cars equipped last year and the locomotives equipped within the last eight months. As yet we have had but one knuckle broken (that on a car) and that was caused by an accident. One of the engines equipped in this manner is double-crewed most of the time for service both night and day. This serves to illustrate the fact that the proportion of breakage to M. C. B. couplers on switching roads is much less than many believe to be the case.

I do not find, in actual practice, the trouble anticipated by Mr. P. Leeds, in his paper before the Central Association of Railroad Officers, expressed as follows: "Flange wear or crowding the flanges against the rail, or that the bar is not strong enough for our modern 80,000 and 90,000-pound capacity cars. We handle hundreds of these cars and the number of breakages of couplers is no greater than with other cars. We do find, however, that when these heavy cars strike very hard the load shifts, in some instances forcing the end out of the car, but not breaking the bar. I have seen cases of rear end collisions and trains breaking in two, and have found that in such accidents the damage to M. C. B. bars was not one-fourth as great as that to link and pin bars. Cars are not as liable to telescope when equipped with M. C. B. couplers as when equipped with link and pin drawbars."

The new station of the Pennsylvania Railroad at Jersey City, that is to replace the one recently destroyed by fire, is progressing rapidly. The new station will have a steel frame sheathed with copper, and the train shed is to be extended 125 feet toward the water. It will then be 777 feet long and 256 feet wide. The waiting room will be 80x97 feet, including the ticket and telegraph offices and telephone room. Two spaces 40x65 feet will be occupied by the restaurant and dining rooms. The improvements will cost \$400,000, and the arrangement of the rooms will be more convenient, and passengers will go directly from the ferry to the trains by a distance shorter than before.

CONTRIBUTIONS TO PRACTICAL RAILROAD INFORMATION.

Chemistry Applied to Railroads—Second Series—Chemical Methods.

XXV.—Method of Determining Tin in Phosphor-Bronze.

By C. B. Dudley, Chemist, and F. N. Pease, Assistant Chemist, of the Pennsylvania Railroad.

Explanatory.

Phosphor-bronze, as is well known, is normally an alloy of copper, tin and phosphorus, the proportions of the three constituents varying somewhat with the use to which the alloy is to be put. Phosphor-bronze bearing metal, on the other hand, contains lead, in addition to the other constituents, the usual proportions being a little over 79 per cent. of copper, 10 per cent. each of lead and tin and a little less than 1.00 per cent. of phosphorus. There may be a number of other elements present as impurities, zinc and iron being the most common. The

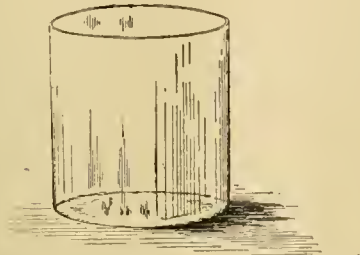

FIG. 1.

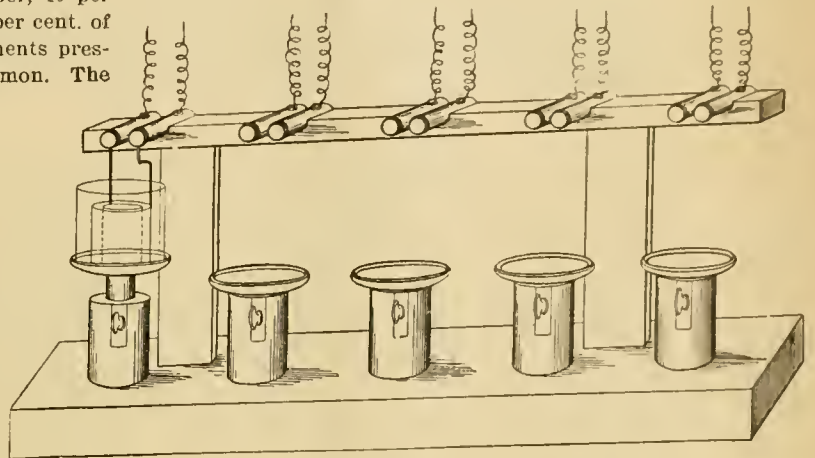

FIG. 4.

importance of a sufficiently rapid and reliable method of determining tin in this alloy is very great. Excepting the phosphorus, the tin is the most expensive constituent, and the amount of phosphor-bronze bearing metal, or closely related alloys in use at the present time, is something enormous. In

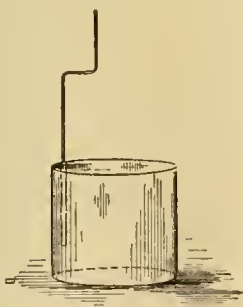

FIG. 2.

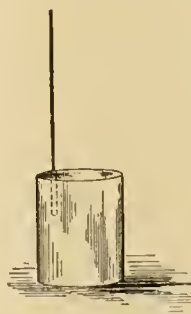

FIG. 3.

our laboratory alone at present the number of bronze analyses averages not less than 15 per month. Until recently the method we have used has been to weigh the tin as oxide. This method was described in full in article Number IX. of this series, published in the "American Engineer and Railroad Journal" for August, 1894. The method described below offers some advantages over the one previously used, both in requiring less manipulation, with consequent greater output of results, and in accuracy, and accordingly has been largely used for some months. It is applicable to all copper, tin, lead, phosphorus and copper, tin alloys, where the amount of copper, or of copper and lead together, reaches 75 to 80 per cent., and where these alloys do not contain considerable amounts of disturbing elements, as described below. It is not recom-

mended for use with any of the white metal alloys, as there is a simpler method of treating these alloys.

Operation.

Dissolve 1 gram of fine borings in 20 c. c. of C. P. nitric acid, 1.20 specific gravity, and evaporate until the residue will not adhere to a dry glass rod. Add 10 c. c. of concentrated C. P. nitric acid, 1.42 specific gravity; heat where the temperature is about 275 degrees for 10 minutes; add 75 c. c. of distilled water; stir thoroughly; heat nearly to boiling for 10 or 15 minutes to facilitate separation of the precipitate, allow to settle a little and then filter, washing with distilled water until a drop of the filtrate, evaporated on a piece of clean platinum foil, leaves no residue. Set the filtrate aside to be used later in the determination of the lead and copper. Put the filter, with the hydrated metastannic acid on it, back into the

same beaker, taking care to spread out the filter, and add 10 c. c. of caustic potash solution and 10 c. c. of water, and heat until the metastannic acid is dissolved. The hydrated metastannic acid obtained, as above described, is apt to carry with it copper, iron, lead and possibly arsenic, antimony and zinc. It may also have a little tin in such condition that it does not completely dissolve in the caustic potash solution. These impurities usually adhere to the filter, and the milky appearance characteristic of the liquid, when the caustic potash is first added, soon disappears, so that, when the liquid is clear, or pretty nearly so, especially if the heating has continued 15 minutes, it may be assumed that the action of the potash is complete. Add now 100 c. c. of oxalic acid solution; heat just to boiling and maintain at this temperature for an hour, at the same time passing H₂S gas through the solution. The liquid boiled away during this operation must be replaced from time to time. Filter at once into a beaker holding about 250 c. c. Wash at first with 25 c. c. of the oxalic acid solution, and then with distilled water, until the volume of the filtrate amounts to 200 c. c. Heat on the steam plate until the H₂S gas is driven off pretty completely; add 3 c. c. of ammonia, 0.96 specific gravity; cool and electrolyze. For this purpose have ready the electrical arrangements described below, or the equivalent of these. Attach the zinc pole of the battery, or its equivalent, if other source of electricity is used, to the larger electrode, which has been previously carefully cleaned, dried and weighed, and the other pole of the battery, or source of electricity, to the other electrode, and cover with a watch glass cut in halves. Allow a current of from 0.05 to 0.10 of an ampere to pass from 12 to 24 hours. When it is deemed that the current has passed long enough, wash down the material spattered on the covers and add water from the spritz end of the wash bottle (taking pains to stir the liquid a little) until the level of the liquid is raised a fourth or half an inch. Allow the current to pass one or two hours longer, and if the bright

stem of the tin pole, around which the liquid has been raised by the addition of the water does not show any deposit of tin, it is safe to assume that all but a slight trace of the tin has been removed from the solution. If the stem of the tin pole shows tin when treated as above, continue the current some time longer, and then repeat the test until the stem remains clean after the current has passed at least an hour subsequent to the last addition of water. By the action of the current the solution gradually becomes alkaline. When this is the case, as shown by test paper, it is safe to assume that the electrolysis is complete. The tin being satisfactorily deposited, lower the stand on which the beaker rests, detach the tin pole, dip in distilled water to wash off the liquid containing salts and repeat with fresh distilled water, then dip in alcohol, dry thoroughly and weigh.

Returning now to the material left on the filter from the

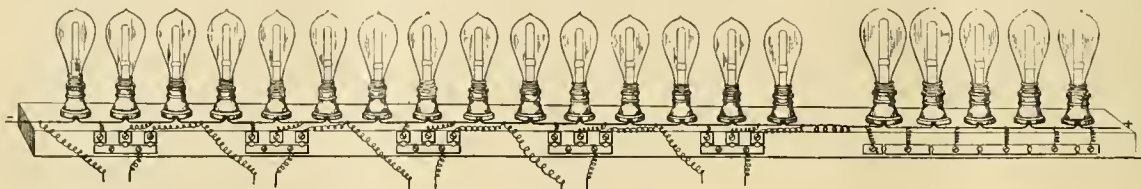

FIG. 5.

oxalic solution after H_2S gas has been passed. This material consists of any copper, lead and zinc which may have been carried down by the tin, and there may likewise be other substances present. Also, if any of the tin escaped solution in the potash, it is here present. Burn the filter in a porcelain crucible at low temperature; treat with 5 c. c. of concentrated C. P. nitric acid, 1.42 specific gravity, and 5 c. c. water until the sulphides are dissolved; filter and add filtrate to the main solution of copper and lead. Burn the filter; fuse in a silver crucible with a little caustic potash; dissolve in water; add ammonium sulphide and heat until any tin present is dissolved; filter; acidify slightly with HCl; allow to stand until most of the H_2S has passed off; filter, ignite and weigh as SnO_2 .

Apparatus and Re-Agents.

A small beaker, about 2½ inches in diameter at the bottom and 3¼ inches high, can be used for the electrolysis; but a jar, made for the purpose, shown in the cut Fig. 1, of the dimensions given above, and about 2¾ inches in diameter at the top, avoids the flange and lip of the beaker, which are apt to be in the way.

The larger electrode, shown in Fig. 2, is a cylinder of platinum foil, open at both ends, 1¾ inches high and 2 inches in diameter. The wire support is 3-64 inch in diameter, and is riveted to the cylinder. It has an offset to adapt it to the binding posts of the electrical arrangement. The wire projects about 3 inches above the cylinder. This electrode weighs 15 to 18 grams.

The smaller electrode, shown in Fig. 3, is likewise a cylinder of platinum foil, open at both ends, 1 5-16 inches in diameter and same height as the larger electrode. The wire support is same size wire, projects same distance above the cylinder, and is likewise riveted to it. This electrode weighs about 12 grams.

The supports for holding the electrolyzing jars during electrolysis are shown in Fig. 4. The material, except the set screws and binding posts, is wood. The length of the base is 2 feet and the width 6 inches. That part of the support for the electrolyzing jar which has the set screw is 2 inches in diameter and 3½ inches high. The movable part of the support for the electrolyzing jar is 3 inches in diameter at the top, and the stem is 5½ inches long. The distance from the top of the base to the bottom of the support for binding posts is 11 inches. The support for the binding post is 1 inch thick and 2 inches wide, and the binding posts are so arranged as to support the electrodes symmetrically in the electrolyzing jar. The loose ends of the wires in Fig. 4 connect with the loose ends of the wires in Fig. 5.

The difference of potential between the binding posts to which the two electrodes are attached, some two or three volts, is such that with the size of electrodes and volume of solution given above a current of from five to eight or ten hundredths of an ampere results. This difference of potential may be obtained from a battery of two or three gravity cells, but since batteries are so difficult to keep in good order, especially if they are not in constant use, and since the Edison current is so common, it is much more convenient to use this current. But the lighting system has a difference of potential of 110 volts between the two wires, and consequently some devices are necessary to bring down the voltage. The arrangement illustrated in Fig. 5 has been worked out from the suggestion given in Dr. E. F. Smith's manual of "Electro-Chemical

Analysis." It is perhaps more elaborate than is necessary, but where a good deal of work must be done, it has been found to be very serviceable. It is fitted up, as will be observed, to carry on five determinations at once. The base of the arrangement is of slate, 4 inches wide, 1 inch thick and of sufficient length to carry five 16-candle-power 110-volt incandescent lamps and 15 12-candle-power 110-volt lamps. It is not essential to have the slate base all in one piece. It will be observed that all the lamps are connected in series, the right-hand end having the positive wire of the Edison current attached to it, and the left-hand end the negative. The five lamps grouped at the right of the cut are 16 candle-power, and so connected, as is readily seen, with the plugging strips on the edge of the slate that any one, two, three, four or all of them, can be cut out by simply inserting plugs in the holes made for them. The other 15 lamps are grouped in sets of three each, and are so

arranged with plugging strips under each group, as is readily seen, that when the two free wires are connected through the electrolyzing solution and a plug is in one of the three holes of the group a shunt circuit is formed. If the plug is in the right-hand hole, the shunt circuit takes in three lamps; if it is changed into the next hole, the shunt circuit takes in two lamps, and if to the next hole, one lamp. This arrangement makes it possible to secure a very wide range of difference of potential at the binding posts above the electrolyzing jar. For example, if there is a plug in each of the five holes below the 16 candle-power lamps, and also one in the right-hand hole in the first group of 12 candle-power lamps, the differences of potential at the binding posts connected with this group will be about 23½ volts. Again, if all the plugs under the 16 candle-power lamps are taken out, and the plug under the first group of 12 candle-power lamps is transferred to the left-hand hole, the difference of potential between the binding posts will be about one volt. By varying the plugging, almost any desired voltage between these two extremes can be obtained. It is evident that by using lamps of different capacity, or by using more or less of them, still wider variations of voltage may be obtained. A switch, not shown in the cut, makes it possible to shut off the current when the apparatus is not in use. It is difficult to give positive directions about the plugging necessary in using the apparatus described above, since the voltage in the mains is apt to vary a little, with the distance of the apparatus from the central station; also the switch, the wires, and the plugging devices used, vary with the different constructions, with corresponding effect on the voltages in the shunt circuits. Still more important also is the variable introduced when one, two, three, four or five determinations are being made at once. Each new determination introduced changes the voltage at the binding posts of all the others which are in the circuit, with a consequent change in the current passing, and hence a change in the plugging becomes necessary to counteract this. The best course to pursue, if an arrangement as above described is made use of, is to connect a delicate ammeter in circuit with the determination and make a schedule of the plugging required when one, two, three or more determinations are being made at once. It may be said, however, that if the apparatus is approximately as described above, and one, or even two, determinations are being made at once, successful results will be obtained if there are three plugs in the group of 16 candle-power lamps, and the right-hand hole of each group of 12 candle-power lamps has a plug in it. The lamp arrangement is supported on a wooden frame, not shown, with the support for holding the electrolyzing jars underneath it. It is desirable to use porcelain sockets for the lamps, as they are not corroded by the fumes of the laboratory, and of course insulated wire should be used throughout for the connections. The plugging arrangements are made of brass and should be kept well lacquered. Turning the plugs in the holes occasionally keeps the contacts good.

The caustic potash solution for dissolving the hydrated metastannic acid is made by dissolving 200 grams of C. P. caustic potash in one liter of distilled water. This solution is not easy to filter, and should be allowed to stand and settle, the amount for use being drawn out with a pipette.

The oxalic acid solution is made by dissolving 200 grams of C. P. oxalic acid and 5 grams of oxalate of ammonia in 1 liter of distilled water and filtering. This solution is nearly a sat-

urated one, and should not be allowed to get cold enough to deposit crystals.

Calculations.

The tin on the electrode being metallic, no calculations are required. For the tin not soluble in caustic potash the following data are applicable. Of course the amount obtained must be added to the amount on the electrode.

Atomic weights used: Tin, 118; oxygen, 16; molecular formula, SnO_2 . Since 78.67 per cent. of the binoxide is metallic tin, the weight found, expressed in grams, multiplied by this figure, gives the amount of metallic tin in the precipitate.

Notes and Precautions.

It will be noted that this method separates the tin from the mass of the copper, lead, zinc and iron associated with it in the alloy by means of nitric acid, dissolves the resulting metastannic acid first in potash and then in oxalic acid, separates the small amounts of copper, lead, zinc, arsenic and antimony, if any, carried down by the tin by means of hydrogen sulphide, and, finally, electrolyzes the tin in oxalic acid solution.

So far as our experience goes, the only element that really causes trouble in this method is iron. Whatever arsenic, antimony, copper, lead and zinc are carried down with the metastannic acid are subsequently separated as sulphides in the oxalic acid solution. But iron, aluminum, and possibly manganese, go into solution with the oxalic acid, and remain with it

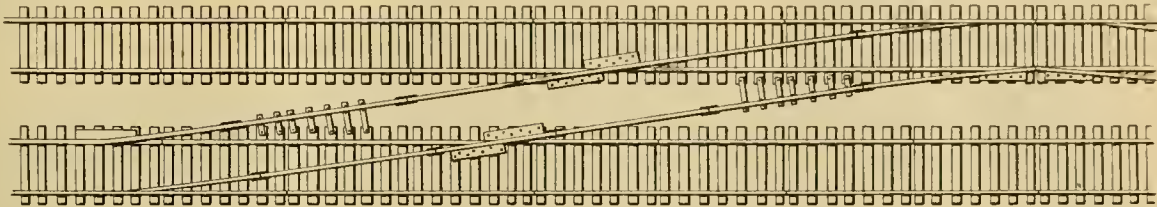

Coates' Emergency Crossover.

after treatment with H_2S . The subsequent behavior of manganese, and also the behavior of nickel and cobalt throughout, our work has not led us to investigate sufficiently, as yet, as these rarely occur in the bronzes we have to deal with. Of the iron and aluminum, the latter separates as Al_2O_3 during the electrolysis and causes no trouble. The iron goes with the tin as metal. The presence of iron in the oxalic solution is readily shown by the color. Usually, with good bronzes, the oxalic solution is water white, or so nearly so, that the iron can be ignored. If, however, this is not the case, the tin and iron on the electrode are dissolved in dilute hydrochloric acid neutralized with ammonia and treated with ammonium sulphide, the resulting sulphide of iron being filtered off. This is subsequently dissolved in dilute sulphuric acid, passed through the reductor and titrated with permanganate. The amount of metallic iron is, of course, deducted from the weight of the tin.

It is never safe to assume that all the tin has been dissolved in the potash and subsequently in the oxalic acid. Usually, in good bronzes, the amount of this tin is small, but we always find it present, and sometimes in quite considerable amount. The most reasonable explanation that we can give of this residue is that it is oxide of tin formed in the foundry while the metal is molten and ignited by the heat to such an extent as to be insoluble in almost any re-agent without fusion. This has not, however, been demonstrated.

The treatment of the metastannic acid with potash before solution in oxalic acid is essential; at least, we have not succeeded in obtaining solution of the metastannic acid without this preliminary treatment.

If H_2S gas is allowed to remain in the oxalic acid solution there is danger of complications during the electrolysis, which it is better to avoid. The possibilities have not all been investigated, but the sulphur separated goes down on the smaller electrode and insulates it sufficiently to cause trouble.

As is well known, successful electrolysis of metals is easiest obtained by passing the current through double salts. The amount of potash and oxalate of ammonia used and the 3 e. c. of ammonia added just before electrolysis seem to furnish the proper amount of bases to form with the tin the necessary double salt.

Some care is required in managing the current. If too much is used, especially at first, the tin comes out spongy and sometimes discolored and black.

It sometimes happens that some oxide of tin separates in the liquid during the electrolysis. This peculiarity is rare, and no explanation of the behavior has been found. When it does occur it is better to start afresh.

It would be difficult to indicate all the sources from which information has been obtained in working out this method. No special claim for originality is made.

COATES' PORTABLE EMERGENCY CROSSOVER.

The form of crossover shown in the accompanying engraving was devised by Mr. F. R. Coates, Roadmaster of the New York Division of the New York, New Haven & Hartford Railroad. Its object is to arrange all the parts necessary for a crossover connection of a double track railroad so that they may be carried as a part of the wrecking outfit and installed in a few minutes for running around a wreck or obstruction on either track. Mr. Coates tells us that under favorable conditions in daylight the various parts have been put together and an engine run over them in $6\frac{1}{2}$ minutes. At night it has been made ready for use in 25 minutes, including the unloading from cars, and under ordinary conditions in daylight it may be put together in 15 minutes. The change may be made from straight track to crossover in one minute. The advantage possessed by such a device will be readily apparent.

By the use of various sized blocks under the frog and raised switch points, it is readily adapted to any size of rail. The parts of the crossover are all numbered, so as to

render it easy to place them properly. The plates for making the tie extensions are attached to the base of the rail by clips, which are easily adjusted to fit the ties. Slots in the short angle bars on the frogs are constructed so that by taking a bolt in each bar and sliding the bar back the middle piece of the frog may be lifted out and it may be replaced when it is desired to use the crossover.

In addition to being useful at wrecks, Mr. Coates has found it convenient in single track lines for setting off steam shovels, pile drivers and camp cars, also for replacing derailed engines. This emergency crossover may be used in place of split switches at outlying sidings, which are not used frequently, its advantages in this connection being an unbroken main line, as far as this portion of the switch is concerned.

The crossover is controlled and manufactured by the Q & C Co. of Chicago and New York.

THE NEW YORK RAILROAD CLUB.

At the annual meeting of this club, held Nov. 17, Mr. M. N. Forney presented a lecture entitled, "Conduct and Character," addressed to railroad and supply men. The meeting was unusually well attended, and the speaker had an attentive and appreciative audience. The lecture was able, full of thought and high ideal. Mr. Forney's position and long, upright career gave force to his expression, and the underlying principle throughout was, "How to do the best with our endowments." Apt quotations and illustrations, together with the speaker's pleasant way of putting things, made the evening enjoyable, as well as profitable and elevating.

Mr. H. H. Vreeland, President of the Metropolitan Street Railway, of New York City, was elected President of the club. Mr. Vreeland has had a remarkable career in railroad work, and after a varied experience on steam railroads, has reached the highest office in one of the most important street lines in this country.

A mile of railroad track rolled in an hour, is the record-breaker of the Illinois Steel Company's South Chicago rail mill one night last month, as reported in the New York "Commercial." We are not told what size of rail section was being rolled at that time, but the amount turned out by one day and one night shift is stated to be 3,004 tons.

AN IMPROVEMENT IN FLOORING MACHINES.

A new wood-working machine, known as the "Six-Roll Double Cylinder Lightning Flooring Machine," has been placed on the market by Messrs. J. A. Fay & Co., 516 to 536 West Front street, Cincinnati, O. It is designed for the purpose of combining large capacity, efficiency and economy with durability. It is built in two sizes, to plane four sides of pieces 10 and 15 inches wide and 6 inches thick. The frame is massive and is proportioned and arranged to resist the stresses of heavy work, one feature being heavy girths under the working parts. The joints are made with care and the system of interchangeability of parts adopted by these builders is followed.

The cylinders are two in number, made from solid steel forgings, with four faces slotted to receive two or four knives and chip-breaking lips for working cross-grained lumber. The upper cylinder is mounted in a heavy yoked frame, has journals $2\frac{1}{4}$ inches in diameter and runs in self-oiling bearings

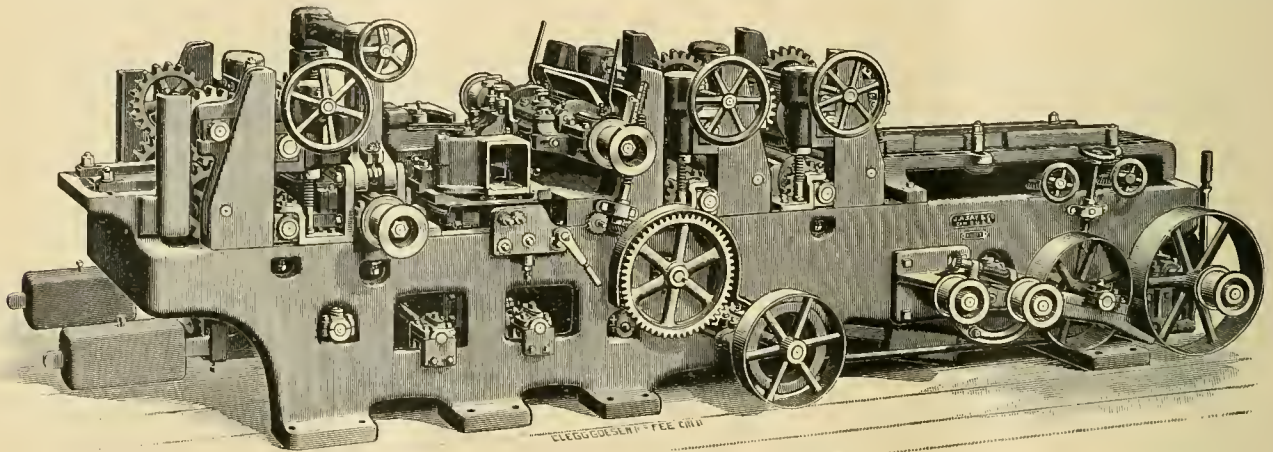

A New Six Roll Flooring Machine.

$10\frac{1}{2}$ inches long. It has double-flanged pulleys close to bearings on each end, fitted on taper bearings, secured with wrought nuts. The cylinder-raising screws are outside of the frame, and are fitted with ball-bearings and a device for quickly taking up all lost motion in the screw caused by wear of the threads. The lower cylinder is mounted in a heavy yoked frame. It has $2\frac{1}{4}$ -inch journals in self-oiling bearings $10\frac{1}{2}$ inches long, and is vertically adjustable at each end. It is driven by flange pulleys at each end.

The matching works are heavy. The arbors are of steel $1\frac{1}{4}$ inches in diameter where the cutter-heads are applied, and revolve in long, self-lubricating bearings, both of which are adjustable vertically and horizontally, and are rigidly locked in any desired position by a lever conveniently located outside the frame. The top plate of each matcher hanger is detached from the main casting for convenience and economy. It will match stock as narrow as $1\frac{1}{2}$ inches. A patent weighted matcher clip has an adjustable toe, hinged to the matcher hanger to produce uniform pressure on the material. Shaving hoods are provided, which can be swung out of the way to give access to the heads.

The feed works consist of six large feed rolls, 8 inches in diameter, driven by a train of powerful gearing, each gear being on a shaft extending through the machine and running in babbited bearings. The expansion gears on the feed rolls are inside the frame, and run in bearings. The screws for raising the rolls do not revolve, the rolls being mounted in sleeve housings that travel on the screws. This makes the roll adjustment very easy, as the pressure weights are not lifted. All the roll boxes are long and large in diameter. The feed-out roll is covered and provided with scrapers. The weight levers are inside the frame, and move freely. They

furnish three speeds of feed, viz., 30, 45 and 60 feet per minute. The feed is under instant and positive control of the operator by means of a lever engaging a ring friction.

The pressure bar in front of the upper cylinder is adjustable to and from the cut, and has a chilled toe to reduce wear to a minimum. The bar behind the cut is adjustable for difference in thickness of material. The bars in front of and behind the lower cylinder are adjustable to and from the cut, and are vertically adjustable for varying depths of cut. The bar over the lower cylinder is adjustable on heavy stands, and securely locked in position. It may be instantly swung over from either side by simply loosening one nut. A continuous pressure bar extends over the matching works with independent adjustment, and may be quickly thrown out of the way to give access to the heads.

This machine is equipped with a new and improved belt-tightening apparatus for both cylinder and side-head belts, permitting rapid adjustment while the machine is running, and permitting the use of endless belts, that run more smooth-

ly and do not require to be cut for the stretch to be taken up. The riding of matcher belts, one on another, as under old methods, is avoided.

THE TRACK TANK.

In a paper upon locomotive water supply stations, read before the Western Society of Engineers, Mr. T. W. Snow made the following unfavorable observations concerning track tanks:

"The track tank was first used by the London & North Western Railway, some thirty-odd years ago. It consists of a shallow trough about 18 inches in width and not to exceed 6 inches in depth, and of various lengths, usually 2,000 feet. Every locomotive tender must be equipped with an inclined scoop or trough, mounted on the front of which is a pony truck or pair of wheels to reduce friction, and, indeed, to enable the device to escape destruction. The speed of the train is cut down to 20 miles an hour when taking water, or at least this speed gives greatest flow. Time of delivery averages 3,000 gallons per minute. The track tank costs about \$1 per lineal foot, and in a recent instance was worn out by the truck wheels in two years of service. The bottom plate was 5-16 inch in thickness. The objections to it in this climate are that an expensive steam heating plant must be maintained in winter; also, a gang of men to chip ice from the rail for the car wheel flanges. About as much water is wasted as is used in the passage of the scoop. There are two methods of warming the water, one by blowing live steam through it at intervals, and again by placing a sumphole in the center and drawing the water through a suitable pump, forcing it through a heater and returning to the track tank at the ends."

The Southern Pacific has just placed orders for 51 new locomotives of several different types. The Schenectady Locomotive Works will build 25, and the Cooke Locomotive Works will build 26.

THE HORNISH MECHANICAL LOCOMOTIVE BOILER CLEANER.

Our engravings illustrate a boiler cleaner for locomotives which has been developed by Mr. F. W. Hornish of Chicago, Ill., and the arrangement shown is applied in such a way as to permit of removing the scale forming compounds of the water without interfering with the operation of the engine, and, we are also informed, without the necessity for the removal of the apparatus in the ordinary repairs to the boiler. The devices are a skimmer placed above the tubes and near the front end of the boiler and attachments placed in the water legs and connected to the blow-off cocks, as indicated in the engraving. No compounds are used in connection with it, and the object of the arrangement is to remove the solid matter from the water as it is separated from the feed-water by the heat.

The skimmer is placed as far forward in the barrel of the boiler as the braces will permit. It faces the cab and reaches from side to side of the boiler and between the top of the flues and the top of the boiler, allowing a space for the dry pipe to pass through. The skimmer is placed in line with the natural circulation of the boiler. The impurities are collected

leaky flues and in the repairs necessary to the boiler, as well as in the losses from the use of a large amount of water in washing and in blowing off. When applied to a locomotive on the Chicago & Northwestern Railway it was found to more than double the distance which the engines could run before being washed out.

The strong commercial position given this country by its ability to manufacture steel cheaply and in large quantities, is bound to be very generally recognized in the near future. The use of labor-saving machinery, combined with intelligent labor, is the reason. We have referred to the invasion of foreign countries with American steel, and now, from Mr. Andrew Carnegie, comes the following statement concerning the position of Pittsburg in the steel industry: "There is not a district in this world to which the Pittsburg district cannot to-day send steel and pay the freight and deliver that steel as cheap or cheaper than it can be made at the point of delivery, if we except Colorado, to which the freight is greater than the difference in cost of manufacture at the two points. Should the South be successful in its present attempt to manufacture steel, we may have to except another point. Colorado excepted, the Pittsburg district has the whole world to-day at its feet. Pittsburg is indeed the steel city."

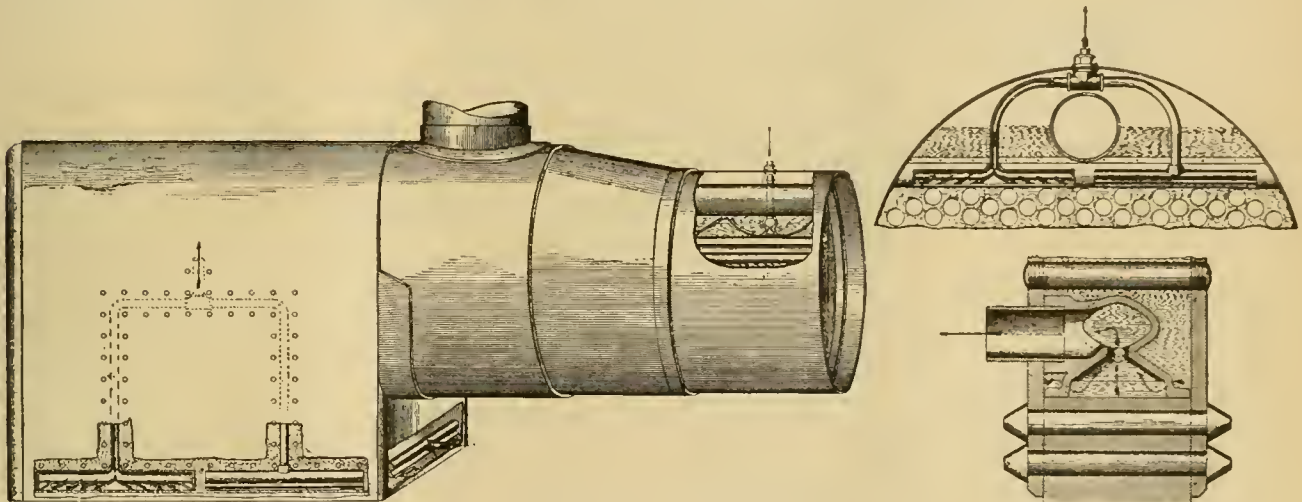

The Hornish Mechanical Locomotive Boiler Cleaner.

in the concave plate and are removed by blowing off without loss of water, the solid matter only being removed. It is so arranged as to make a good surface skimmer the full width of the boiler, and at the same time forms a basin of about 25 gallons capacity to hold the sediment.

The parts which are placed in the water legs can only be applied when the boiler is built or a new firebox put in. The device is the same that empties the skimmer and it is placed upon the mud ring. The sectional view shows the water passages, and what Mr. Hornish calls "suckers" face the mud ring, above which they are raised one-half inch. The size of the openings varies with the distance from the center, this being done to prevent the openings nearest the center from drawing more than their share of the sediment. The devices do not interfere in any way with the ordinary methods of cleaning or washing out, and experience substantiates the claim that they prevent boilers from foaming. The cleaner operates whenever there is circulation in the boiler. Mr. Hornish draws attention to the fact that the method of washing out boilers while the sheets are hot is not only destructive, but also tends to cause the scale to adhere to the plates.

The interesting feature of this device is that it appears to do its work admirably, and as foaming is eliminated the danger of carrying solid and gritty matter into the valves and cylinders is avoided. In a case where the water is very bad a great improvement has been found in the prevention of

BOOKS AND PAMPHLETS.

Handbook of Corliss Steam Engines. By F. W. Shillitto. 197 4 $\frac{3}{4}$ x6 $\frac{1}{4}$ inch pages, with 69 illustrations. The American Industrial Publishing Company, Bridgeport, Conn. Price, \$1.

This is a book which, while especially concerned with the installation of Corliss steam engines, will be valuable to all those who have occasion to set up engines, whether of this type or not. The treatment of the subject is comprehensive and complete, and there is much in it that will be valuable to the owners and engineers of Corliss engines. Engineers will be particularly interested in a chapter in which the author describes his experience with these engines. The application of the indicator has not been as fully treated as many will wish, but the directions for setting foundations and erecting and lining up the engines and setting the valves are its strong points.

Commercial Relations of the United States with Foreign Countries During the years 1896 and 1897. In two volumes. Vol. I. Issued from the Bureau of Foreign Commerce, Department of State (formerly Bureau of Statistics). Government Printing Office, Washington, 1898.

This valuable volume contains a review of the commerce of the world and information based upon consular reports concerning the commercial relations between the United States and other American countries, and Africa, Asia, Polynesia and Australia. Aside from statistics, a great deal of information is given to those concerned in foreign trade. The work of compilation and classification was done under the direction of Mr. Frederic Emory, Chief Bureau of Foreign Commerce.

Up to Date Air Brake Catechism. A Complete Study of the Air Brake Equipment, Including the Latest Devices and Inventions Used. All Troubles and Peculiarities of the Air Brake and a Practical Way to Find and Remedy Them Are Explained. By Robert H. Blackall, Air Brake Instructor, Delaware & Hudson R.R. Illustrated by engravings and two large folding plates. Pages, 230. Norman W. Henley & Co., 132 Nassau Street, New York, 1898. Price, \$1.50.

The author's object as stated in the preface is to present a complete, up to date study of the air brake, so written as to give the rudiments to those who want them and the complete details for more thorough students. The arrangement in the form of a catechism assists in clearness and is undoubtedly well adapted for the men who will read it most—trainmen, enginemen and those who come into contact with brakes, and especially those who must pass examinations in the principles and operations involved. The system described is the Westinghouse, and it is well and completely described, although many will want to see the high speed brake more completely illustrated. The subjects of inspection, repairs and operation are well handled, and the author's experience makes him an authority, and his methods of explaining the operation of the triple and engineer's valves show that he is accustomed to describe them in simple, concise terms. It is a good instruction book and is also valuable for reference by those who do not study it through. It is the best book of the kind that we have ever seen. The author probably had enginemen, shopmen and air brake instructors specially in mind, but it should be procured and read by every railroad man from the president to the car inspector. After testing the index in several directions, it seems to be excellent, and this is very important in a work of this kind.

A Practical Treatise on Modern Gas and Oil Engines, by Frederick Grover, A. M. Inst. C. E. Second edition, 250 pages. Technical Publishing Company, Limited, 31 Whitworth street, Manchester, England, and D. Van Nostrand Company, 23 Murray street, New York, publishers. Price, four shillings six pence.

This book, as the name indicates, is a practical treatise on modern gas and oil engines. The object of the author was to assist mechanical draftsmen in obtaining the information necessary to enable them to apply their art to the design of gas engines. A general arrangement of the gas engine plant is first described; then the different types of modern gas engines are taken up, together with explanations of methods for calculating their leading dimensions. An important feature is a detailed description of the apparatus required and the calculations necessary for complete gas engine trials, and this subject includes a chapter on the practical analysis of gases. The book concludes with a description of a series of experiments made to determine the effect of the products of combustion when present in explosive mixtures of coal gas and air. This book has been received with special favor, making it necessary to follow the first edition in a short time with the one before us, and this is the best test for a successful book. This is the best book that we have seen on gas engine design, and it is apparent that the author is a master of the subject.

We take this opportunity to state that the books of the Technical Publishing Company of Manchester may be obtained of Messrs. D. Van Nostrand & Company.

"A Catechism of the M. C. B. Rules of Interchange." Issued by the McConway & Torley Company, Pittsburg, Pa. Pages, 40; illustrated, 1898.

This convenient little book contains 100 questions and answers concerning the M. C. B. rules of interchanging of freight cars. It follows the plan adopted by Mr. M. N. Forney in his catechism of the locomotive. The book is illustrated by the diagrams that appear in the Interchange rules, and at the end a series of plates showing the product of the McConway & Torley Co. are included. The idea of the book is a good one. It is intended as an aid to car inspectors and incidentally to direct attention to the merits of the Janney coupler and the other devices manufactured by this company. It is valuable to the men who inspect cars, and will be appreciated. Copies will be sent free on application to the company. The edition for general circulation is bound in leather board to match the books of rules issued by the Master Car Builders' Association. We are glad to have a copy in our library, as an aid to the interpretation of the rules.

Statistical Year Book of Canada for 1897. Issued by the Department of Agriculture, 1898.

Bulletins of the United States Geological Survey, Nos. 88, 89 and 149.

United States Geological Survey Monograph on Fossil Medusæ, by Charles Doolittle Walcott, Government Printing Office, Washington, 1898.

Report of Board of Mediation and Arbitration of the State of New York, Eleventh Annual Report, 1898.

"The Modern Roundhouse Turntable" is the title of a handsome twelve-page pamphlet received from the Westinghouse Electric and Manufacturing Company. It contains excellent engravings, and a clear, brief description of the Westinghouse method of operating locomotive turntables by electric motors. In our June issue of 1897, page 191, the system was illustrated and described in its application on the Chicago, Milwaukee & St. Paul Railway, and in the December issue of the same year, page 416, we described a similar plan in use on the Baltimore & Ohio Southwestern. In both of these cases, as well as in the pamphlet under review, the possibilities for saving in the cost of labor are stated in plain figures. The Westinghouse method of applying electricity to the operation of turntables should be specially interesting to railroad managers, inasmuch as it requires no change in the turntable itself except to attach the drawbar lug to the girder of the table. The motor is simple in its attachment, and the saving to be had is practically all clear gain, because there is no reason why the apparatus should involve any material expense for maintenance in many years.

Electrical Trades Directory and Handbook, 1899. The forthcoming new edition of this valuable publication, which is in its 15th year, will contain a carefully compiled list of British, colonial and foreign electricians, electrical engineers, electric light engineers and contractors, electrical apparatus makers, plant and machinery builders, instrument makers, electric bell makers and fitters, electric light, telegraph and telephone companies, electric light, telegraph and telephone engineers, wire makers and drawers, and of all persons engaged in electrical pursuits throughout the world; also, useful tables and data relating to electric light and traction, electric power transmission, telegraphs and telephones, electricity supply companies, home and foreign government departments. A biographical section gives particulars of the careers of about 320 eminent men who are connected with electrical development. The directory may be obtained from "The Electrician," Salisbury Court, Fleet street, London, E. C., price, 12 shillings.

Baldwin Locomotive Works. Record of Recent Construction. No. 8.

This is the eighth pamphlet in the series, regularly issued by the Baldwin Locomotive Works to illustrate and describe locomotives recently built by them. In it we find a ten-wheel engine for the Atlantic Coast Line, a compound consolidation for the Ottawa, Arnprior & Parry Sound; a six-coupled double ender and a compound of the same type, for the Government of Victoria; a compound consolidation and a compound six-coupled engine for the Chinese Eastern, a mogul for the United States of Columbia, a compound consolidation for the Moscow-Windau-Ribinsk Railway of Russia, and a number of light engines for foreign roads, among which is a double ender for the Lynton & Barnstable Railway, England. The general dimensions and excellent half-tone engravings of each design are given.

Waterman's Ideal Fountain Pen.—A very attractive catalogue has just been received from Mr. L. E. Waterman, describing and illustrating the large number of his well known pens. The pen itself needs no commendation where it is known, but for ease in ordering we recommend readers to send for a copy of this pamphlet. After a decidedly unsatisfactory experience with a number of kinds of fountain pens we obtained one of these, and have found it so perfectly reliable that we are glad to take this opportunity to testify to the success obtained by Mr. Waterman. Upon selecting a pen which suits the hand we believe that our experience will be corroborated by everyone who orders from this catalogue.

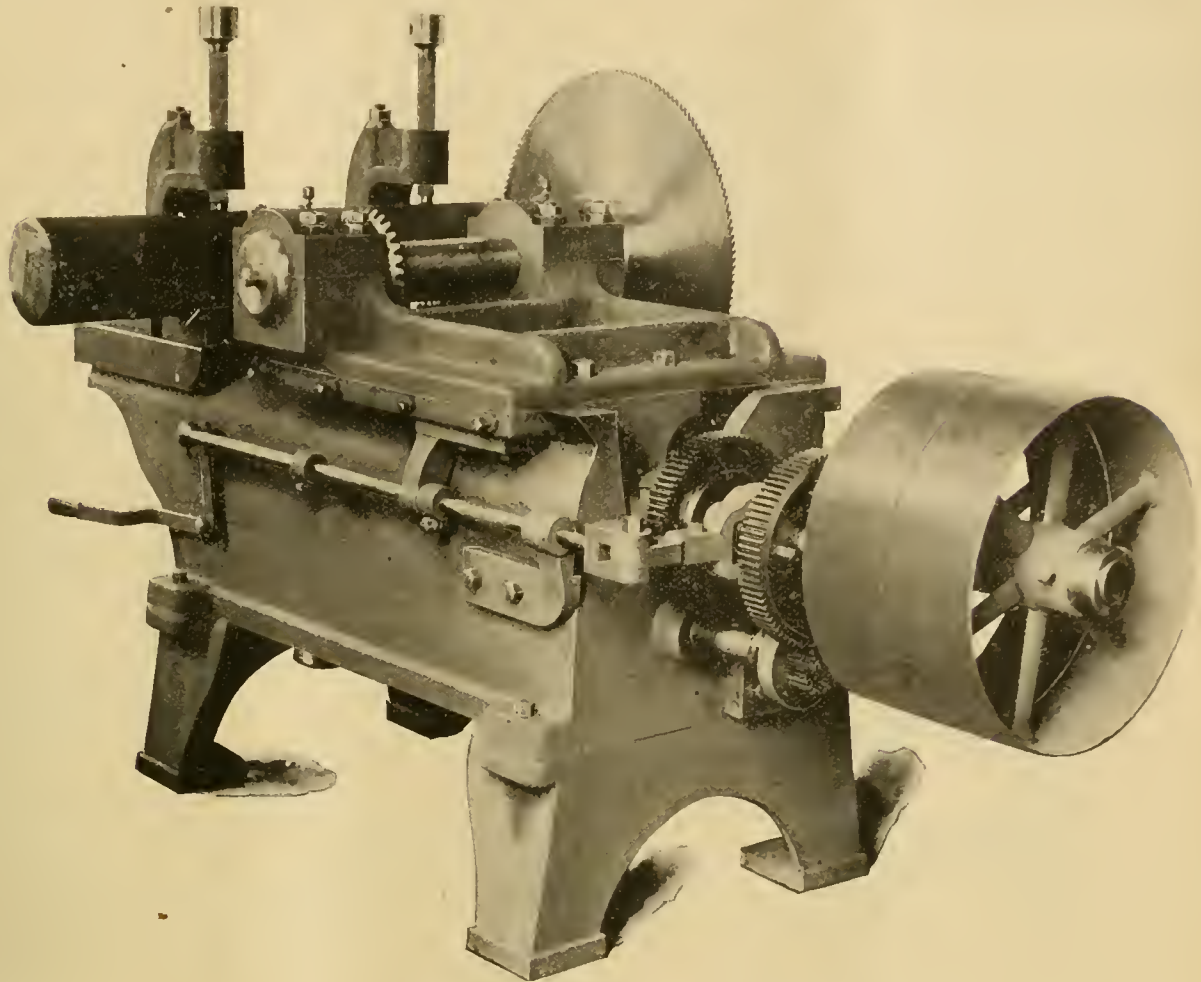

Power Sawing Machine.—Q & C Company.

SAWING MACHINE AND SAW GRINDER.

By the Q & C Co.

The use of cold saws is extending, and a great deal of work formerly done upon planers is now more satisfactorily treated by saws. An example was seen recently at the Juniata shops of the Pennsylvania Railroad, where expansion pads are being cut off obliquely at the ends by a saw, to the relief of the planer.

The Q & C Co. have introduced the machine shown in the accompanying engraving, which is No. 11, and also an automatic grinder used in connection with it, in order to keep the saws in proper condition. This particular machine, No. 11, is intended for cutting large quantities of steel rails, bar iron and steel shafting, ranging in size from 3 to 8 inches. The saw blade is 25 inches in diameter and $\frac{1}{4}$ inch thick, the saw being driven by the arbor. When it is desired to cut large quantities of such material a special chuck is used, which will hold from 3 to 6 pieces at a time, the purpose being to save time in clamping the work. A series of tests recently made in cutting steel rails showed that the saw would make 160 cuts with scarcely a perceptible dullness of the blade.

The weight of the machine is about 3,000 pounds, and it occupies a floor space of $2\frac{1}{2}$ by 7 feet. The saw blade makes 11 revolutions per minute, the cutting speed is 7-16 inch per minute, and the travel of the saw carriage is 10 inches. The machine has a quick return of the carriage after completing the cut.

The automatic grinder is used to resharpen the saws, and it

will work with very little attention and give a correct form of tooth. The construction of the machine and the method of attaching the saws thereto is clearly indicated in the engraving.

The address of The Q & C Co. is 700 Western Union Building, Chicago, Ill.

Bolts with "T" heads for holding down the top castings or

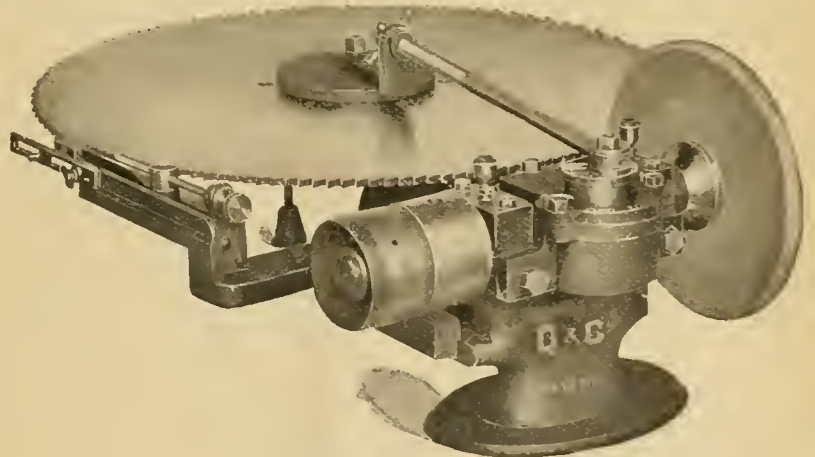

Automatic Saw Grinder.

steam domes offer advantages over the usual method of fastening them with studs screwed into the top dome ring. To use "T" head bolts it is necessary to provide cavities in the ring to receive the heads, and by doing this all trouble with studs that must be drilled out if broken off is done away with. The Pittsburgh Locomotive Works have used these bolts for about 17 years, but the practice is not in general use by other builders.

CONTINUOUS RIVET FURNACE.

The accompanying cut illustrates a new rivet furnace constructed by Messrs. Ross and Gibson, of 68 Cheapside, London. The furnace has a fireplace below, communicating by means of ports with a combustion chamber, into which opens a hopper surmounted by a chimney. The hopper is filled with rivets through the door at the top, and when hot they are withdrawn through the combustion chamber by the upper door in the side. Thus the flame on its way to the chimney is drawn by the draught through a column of rivets 9 inches or 10 inches high, and while those at the bottom of the hopper are ready for use, those at the top—if the supply of rivets be kept up—will always be nearly cold.

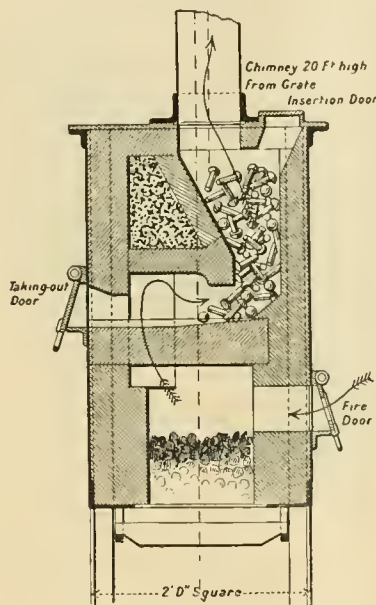

A Continuous Rivet Furnace.

Air is admitted through a regulator in the fire door to insure perfect combustion of the gases before they reach the rivets, and plenty of room is given in the combustion chamber for thorough mixture of the air with the gases. If properly worked, the furnace makes no smoke. When rivets of different lengths are wanted they are put in the hopper in layers and preserve their relative order in their descent through the hopper. Special rivets may be put into the combustion chamber through the extraction door. The furnace may be easily moved from place to place."—"The Engineer."

ELECTRIC MOTORS FOR RAILROAD SHOPS.

That electricity is destined to supersede every other means of general power distribution is no longer a matter of doubt in the mind of anyone who has made a study of the matter, even in the most cursory manner. Tests made by many of the most prominent engineers of the country during the past few years have demonstrated the fact that the usual or average loss of power through the employment of shafting and belting is not far from 40 per cent. In some shops the losses are as low as 25 per cent., but, on the other hand, in other heavy machine shops losses have been shown as high as 80 per cent. A notable demonstration of the heavy loss prevailing in some shops was that of the Baldwin Locomotive Works of Philadelphia, prior to the time that this company adopted electric motors.

The Consulting Engineer for the Baldwin people at the time the matter was taken up was Professor J. J. Flather; and his report, to the effect that 80 per cent. of the power employed by the Baldwin company was used in operating shafts and

belting alone, led to the immediate installation of electric motors.

Professor Flather has made numerous investigations and reports for a number of companies, and some of the notable records of losses are as follows:

Hartford Machine Screw Company, 25 per cent.

Pond Machine Tool Company, 41 per cent.

Yale-Towne Company, 49 per cent.

Bridgeport Forge Company, 50 per cent.

Baldwin Locomotive Works, 80 per cent.

Many examinations other than those enumerated have been made by Professor Flather, and while in some shops where light machinery is used and almost constantly employed, losses were found to be as low as 25 per cent., the general average as reported was 42.3 per cent.

Small wonder is it then that the value of the electric motor is universally recognized, and that it is generally conceded that machine shops of every description must adopt electric motors or find themselves far behind in economical production.

The question as to the type of motor best adapted for conditions in a given shop is wholly a minor one and does not affect the general proposition of their necessity. Engineers frequently disagree on the question as to whether direct-connected or geared motors should be employed, or whether motors for given groups of machines should not be belted to shafting from which belts may be run to individual machines; but there is no disagreement on the general proposition that electricity is to be the general power distributing medium of the future.

Briefly enumerated, the advantages accruing from the adoption of electric motors are as follows: 1. Saving in power. 2. Economy of floor space. 3. Increased light and cleanliness, due to elimination of shafting and belting. 4. Wider range of speed for machines and tools. 5. Increased product in a given time. 6. The theoretically complete elasticity of the system in carrying power to machines or buildings more or less remote from the point of generation of power, notably where additions are made to shop buildings or plants.

The "American Engineer," recognizing the absolute truth of the statement of advantages noted above, will devote considerable space in the future to electric motors and motive power for railroad shops, and to this end will endeavor to cover the subject completely in its columns. The matter will be taken up fully and in technical detail, and arrangements have already been made to publish plans and shop costs of railroad plants already operated by electric motors.

A NEW COUPLER GAUGE.

A coupler gauge that is most admirably adapted to its purposes is shown in the accompanying engraving. It was designed by Mr. Thomas Fildes, division master car builder, at Chicago, of the Lake Shore & Michigan Southern Railway. We give a drawing of the gauge with a superimposed outline (in dotted lines) of the coupler contour. It will be seen that the gauge sets firmly into the face of the jaw, and in so doing presents three points for gauging, A, B and C. At A the outer arm of the gauge carries a flat graduated pin, with a sliding fit. When the guard arm becomes so deformed or out of line that this pin will pass through the gauge when applied up to the shoulder of its head—a distance of five-sixteenths of an inch—the permissible safe variation from contour is indicated. The graduations on the pin show during inspection from time to time how close to the safe limit the variation is proceeding.

The function of the caliper B is clearly shown by the drawing and its legend. A mark on the body of the gauge shows by register with the indicator end of the caliper, the position of the knuckle face from normal up to a quarter inch variation, which latter, with the five-sixteenths at A, is the permissible extreme—which is $5\frac{1}{4}$ in. from edge of knuckle to guard arm.

The projecting arm, or point C, is used as an alternative with

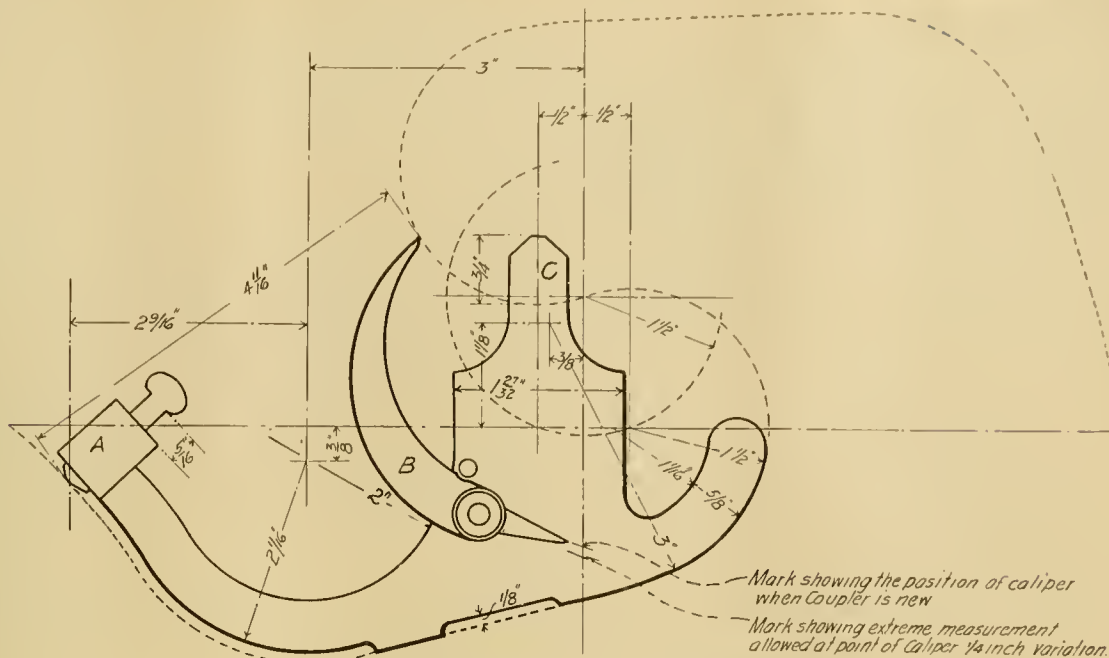

A New Coupler Gauge to Show Allowable Wear.

or check upon the caliper. When the gauge is set as shown, this projection, C, rests upon the top of the knuckle, and when the latter is so far out of its proper position that this projection will drop inside the knuckle, the permissible safe variation at this point, three-quarters of an inch (which is the practical equivalent of the variation of one-quarter inch at the point of the caliper, before explained) will have been reached. The large dimension of this projection C—one and twenty-seven thirty-seconds of an inch—is used for gauging the diameter of the pivotal pin holes.

This gauge has proven its worth and its complete efficiency in daily practice.—“The Railway Master Mechanic.”

“CUPPED” FIREBOX SHEETS.

The method of pressing the side sheets of locomotive fireboxes into cup-formed depressions at the stay bolt which was first brought out by the Chicago, Rock Island & Pacific, has now been used long enough to demonstrate its advantage in some directions, and to show that there are no attendant disadvantages. The breakage of staybolts and their weeping or incipient leaking go hand in hand, and arise from the same cause, the unequal movement of the firebox sheets due to expansion and contraction. The weeping around the staybolts has been entirely overcome by the cupping process, and while the breakage of the bolts seems to have been improved conservative people will wait for longer experience before expressing positive opinion on this point.

The process of cupping the sheets was described in our issue of September, 1897, page 321. The side sheets only are so treated on the Rock Island, but other roads in their experiments have extended it to the crown sheet also. The effect of the cup seems to be to provide means for the sheet to “give and take” at each staybolt, and as the inside firebox sheets move under changes of temperature a portion of the motion is taken up in the sheets themselves to the relief of the bolts from a part of the bending to which the destruction of staybolts is now generally attributed. The sheets as a whole seem to be stiffer than when flat, but there also appears to be an opportunity for local bending in a transverse direction from which the relief is found. It is seen to be advantageous to use thin firebox sheets when cupped, and better results have been obtained with 5-16-inch than with 3/8-inch sheets.

The effect of the fire impinging on the heads of the stay-

bolts in the side and end sheets under ordinary conditions has been to reduce their life, and to cause the sheets to be eaten away around the heads, causing leakage. The immediate remedy is naturally to rivet the beads a little tighter, but this when carried too far causes other troubles. The eating away that is referred to does not appear to be explained by leakage at the bolts, because in some cases leakage is a result rather than a cause of it. The cupping, in which the sheets are bulged outward at the staybolts, serves to defend the heads from the fire and this trouble stops.

At the Rock Island shops the cupping is done by the hydraulic punch. The sheets are laid out with prick punch marks for the staybolts, and after the cupping the sheets are drilled. They are annealed to overcome the local internal stresses that may be set up by the cupping. The form of the punch and die is shown in the description already referred to. An interesting experiment was recently tried to show the effect of the cupping upon the tensile strength of the plate. A narrow plate of firebox steel was cupped and “pulled” in a testing machine. It was expected that the break would occur through one of the cups, but the plate always broke in the straight parts.

LEAD AND ZINC PAINTS.

A series of exposure tests of lead and zinc paints are reported in a recent issue of the Railroad Gazette by Mr. G. R. Henderson, with the following results:

Tin.—The best results were obtained with first coat white lead and second coat white zinc. The second coating of zinc gave generally the best results, and the second coating of lead the worst.

Galvanized Iron.—The same remarks apply to galvanized iron that were given for tin.

Sheet Iron.—The mixture of one-third white zinc and two-thirds white lead, for both coats, gave the best results on this material, and in general the zinc paints gave better results than the lead paints.

Poplar.—The second coats of zinc showed up well on poplar, no matter whether the priming coats were white lead or white zinc, or mixed lead and zinc. The lead second coating showed up the worst on this material, but in each case where the second coat was of zinc, totally or partially, the paint was in a perfect condition.

White Pine.—The remarks made relating to poplar apply to white pine also.

Yellow Pine.—This material seems to be difficult to properly treat with paints; the best results were obtained with the first coat of lead, and the second coat of lead and zinc mixed. Where the first coat was of lead and zinc mixed, or entirely of zinc, the results were poor throughout, which seems to indicate that as a general thing the lead is better for priming on this material.

Conclusion.—The lead priming and zinc coating is generally good for tin, galvanized iron, poplar and white pine. Sheet iron showed up best with both coats of mixed paints. Yellow pine appeared best with the first coat of lead and the second coat of lead and zinc mixed. Comparing the materials which were painted, we find that generally poplar retains the paint better than white pine, and would, therefore, be preferred for siding on buildings, etc., Yellow pine seems to be the worst of all for this purpose. Black iron, as a whole, seems to retain the paint better than either tin or galvanized iron.

PERSONALS.

Mr. G. D. Churchward, Locomotive Superintendent of the Imperial Chinese Railways, has resigned.

Mr. A. C. De Haven has been appointed Master Mechanic of the Omaha, Kansas City & Eastern, with headquarters at Stanberry, Mo.

Mr. H. E. Clacas has been appointed Master Mechanic of the Atchison, Topeka & Santa Fe at La Junta, to succeed Mr. John Forster, Jr., resigned.

Mr. Darius Miller, formerly Vice-President and Traffic Manager of the Missouri, Kansas & Texas, has been appointed Second Vice-President of the Great Northern.

Mr. Norman E. Sprowl has been appointed Division Master Mechanic of the New Jersey Central division of the Central Railroad of New Jersey, with office at Elizabethport, N. J.

Alfred Skitt, General Manager of the New York Central's lighterage department, has been elected Vice-President and a Director of the Manhattan Elevated Railroad Company, of New York.

Robert H. Harrison, foreman of the Pittsburg, Fort Wayne & Chicago shops, at Fort Wayne, and for 40 years in the service of the Pennsylvania, has been retired, with full pay, for the remainder of his life.

Mr. John Medway, formerly Superintendent of Motive Power of the Fitchburg Railroad, has been appointed Master Car Builder of the Swift Refrigerator Transportation Company. His headquarters are in Chicago.

William H. Schoenberger died in Cobourg, Ontario, Oct. 16 at the age of 62 years. He was connected with the Schoenberger Steel Company of Pittsburg for a time and afterward associated himself with Messrs. Schoenberger, Blair & Company.

Mr. F. M. Stevens, a brother of Mr. George W. Stevens, Superintendent of Motive Power of the Lake Shore, has resigned his position as General Foreman of the Sormovo Locomotive Works at Nijni Novgorod, Russia, to take a position with the Baldwin Locomotive Works. He was connected with these works some years ago.

Mr. W. C. Ennis, who was for many years Master Mechanic and Master Car Builder of the New York, Susquehanna & Western R. R., has connected himself with the Chicago Pneumatic Tool Company, with headquarters at the New York office. Mr. Ennis enjoys a wide acquaintance among the railroad men of this country, and will be a valuable addition to the staff of the Chicago Pneumatic Tool Company.

Mr. J. S. Turner has resigned as Superintendent of Motive Power of the West Virginia Central & Pittsburgh Ry. to become Superintendent of Motive Power of the Union Pacific, Denver & Gulf, with headquarters at Denver, Col. Mr. Turner's many friends will join us in congratulating him on this advancement and recognition of his ability.

Horace B. Miller, who was one of the founders of the "American Machinist," died of heart failure at Napa, Cal., Oct. 25. He was born in 1839 in Philadelphia, and during the war served under Admiral Farragut. His first newspaper work was begun in Pittsburg, and in 1877 he was associated with Jackson Bailey in starting the "American Machinist."

John H. Dialogue, the noted shipbuilder of Camden, is dead. He began machine work in early life and took care of the repair work of the locomotives of the old Camden & Amboy Railroad; also that of the boats of the Camden & Philadelphia Ferry Company. He entered the shipbuilding business about 1860 and was actively engaged in it during the remainder of his life.

Mr. H. H. Vaughan, Mechanical Engineer of the Philadelphia & Reading, who formerly held a similar position with the Great Northern, has just been appointed Mechanical Engineer of the Q. & C. Co., with headquarters in Chicago. Mr. Vaughan has an excellent standing in his railroad work, and, while he is greatly needed in that field, his continued success is assured either on or off a railroad, and we consider anybody who secures his services as subject to congratulation.

William B. Snow, who was formerly Master Mechanic of the Illinois Central, died in Chicago Oct. 21, aged 77 years. He began railroad work in 1844 at Bellows Falls, Vt., as foreman of bridges and buildings of the Western Railroad of Massachusetts, and was in the car department of that road for two years. In 1848 he became connected with Tracey & Fales, car builders at Hartford, Conn., and in 1850 he took a position with the American Car Company, Seymour, Conn. In 1857 he became general foreman of car work for the Illinois Central and remained there 15 years. After 1872 he was for three years traveling mechanical inspector for the Pullman Company, and from 1875 to 1891 he was Master Mechanic of the Illinois Central.

William M. Wilson, president of the Fox Pressed Steel Equipment Company, died in New York November 17, after a surgical operation. Very few men have more friends among prominent railroad men than Mr. Wilson had, and the news of his death will be a shock to those who saw him apparently enjoying excellent health only a short time before his death. His circle of friends was widened by his connection with the Fox Pressed Steel Company, and at different times with other steel interests, among which were the Otis Steel Company, of Cleveland; the Carbon Steel Company and the A. French Spring Company, of Pittsburg, and the American Coupler Company.

Captain W. W. Peabody has tendered his resignation as Vice-President of the Baltimore & Ohio Southwestern, which he decided to do on account of failing eyesight, and he will retire from active railroad work, although he continues to be a director in the company. He is 62 years of age and has been in railroad work since 1852, when he entered the service of the Marietta & Cincinnati, now a part of the Baltimore & Ohio Southwestern. Since that time he has been successively assistant engineer, president's private secretary, paymaster, master of transportation, superintendent and general manager. From 1877 to 1880 he was general superintendent and general manager of the Ohio & Mississippi Ry., and from 1883 to 1886 president and general manager of the same road. From 1887 to 1890 he was manager of the Trans-Ohio division of the Baltimore & Ohio, at Chicago. In 1890 he was elected vice-president of the Baltimore & Ohio Southwestern and in 1893 became vice-president under the consolidation.

EQUIPMENT AND MANUFACTURING NOTES.

The purchase of the Rhode Island Locomotive Works by Mr. Joseph Letter of Chicago is reported to have been concluded.

We are informed that Messrs. J. G. White & Co., of 20 Broadway, New York, are taking bids on electric railway equipment to go to Australia.

Chicago Grain Doors and Security Lock Brackets have been furnished by the Chicago Grain Door Company for the 500 cars now building by Messrs. Wells & French for the "Soo Line."

The business of the John Stevenson Company has gone into the hands of receivers. Messrs. A. A. Wilcox, of Paterson, N. J., and Louis Stern, of New York, will act, temporarily, in that capacity. The assets are stated to be \$1,175,776. and the liabilities \$788,782.

The Stirling Company of Chicago has just received an order for water tube boilers for the Russian warships now building by the Cramps, at Philadelphia. It is the largest order for water tube boilers ever placed in the United States and covers 35,000 horse power.

The Illinois Steel Company has commenced the manufacture of bridge and structural steel on a large scale, at its South Chicago plant, and has become a competitor for the Carnegie works for foreign orders. The new \$1,000,000 slabbing mill has greatly increased the capacity of this plant for these products.

Arrangements have been made for the absorption of the American Brake Co. by the Westinghouse Air Brake Co., the lease of the former by the latter being surrendered and the equipment and property of the American Company being transferred in fee simple to the Westinghouse people.

J. A. Fay & Co., Cincinnati, Ohio, the largest manufacturers of high grade wood-working machinery, have just sent us a folder printed in red and green illustrating about fifty of their most recently improved machines for working wood. A copy of the folder may be obtained free on application by mentioning this journal. Those in charge of wood-working shops should take this opportunity to ascertain whether they are up to date.

The Chicago Pneumatic Tool Company reports a very satisfactory state of business. In spite of the greatly increased facilities, there is difficulty in supplying the demand for their pneumatic tools and appliances. The principal increase is in the demand for the Boyer pneumatic hammers, riveters and drills. The use of these tools in railroad shops is increasing as their merits in labor saving are becoming appreciated. There is a demand for these tools in manufacturing plants and in the shipbuilding and bridge works, especially for riveting.

The 30 new freight locomotives ordered by the Receivers of the Baltimore & Ohio Railroad about three months ago, 20 of which are from the Baldwin Locomotive Works and 10 from the Pittsburg Locomotive Works, have been delivered and are now in service. These engines are of the same type that have been very successfully used on the second division between Cumberland and Baltimore, and over one hundred are now in service. They are the consolidation type, with 21x28-inch cylinders, and were constructed from designs furnished by the Motive Power Department of the Baltimore & Ohio Railroad.

The William R. Trigg Co. of Richmond, Va., has shown remarkable activity in making preparations for building the torpedo boats and destroyers recently contracted for with the Navy Department. Through Mr. John W. Duntley, President of the Chicago Pneumatic Tool Co., a contract has been signed for supplying a complete pneumatic tool plant, including the compressor. Pile driving has already commenced, and the buildings are nearly completed. Those who have predicted that the plant would not be ready in time to satisfy the requirements of the Government are likely to be disappointed.

Mr. Samuel M. Vauclain, Superintendent of the Baldwin Locomotive Works, and designer of the Vauclain compound locomotive, addressed the students of Purdue University, Lafayette,

Ind., Nov. 12. His subject was "The Compound Locomotive." Among other things, Mr. Vauclain showed how closely the service tests which he had made on Vauclain compound locomotives agreed with tests made at Purdue.

Some unique samples of cast steel worked cold into the form of pitchers are to be seen at the office of Mr. W. S. Calhoun, Eastern representative of the American Steel Foundry Company, Havemeyer Building, New York. The pitchers will hold about three quarts, and they are made of the same quality of steel that is put into the bolsters and other railroad castings made by this concern, and this work shows the degree of refinement that has been reached in casting steel. The pitchers were pressed cold, by the St. Louis Stamping Company, from sheets rolled out from ingots, and we are informed that nearly 100 of these pitchers were stamped without breaking the metal, which is a severe test of the material.

During the past summer the Joseph Dixon Crucible Company of Jersey City, N. J., have added an extension to their pencil factory, 40 by 90 feet, three stories high. It is driven by electric power from a generator placed in the main factory. No expense has been spared in the equipment in the way of up-to-date elevators, furnaces, dry-rooms, etc. The company will also put down an artesian well, several hundred feet in depth, for a supply of water for factory use, and some time during 1899 various other additions will be built to the Dixon Company's already extensive plant. The company was established in 1827, and the volume of business for 1898 has surpassed that of any other year, and the concern is behind its orders in all departments. Because of the variety of its products and their use in many different industries, this may be considered as indicating the satisfactory condition of many business interests.

The Ruesell Snow Plow Company, Tremont Building, Boston, has recently received orders for snow plows, among which are the following: From the New York Central, one wing elevator snow plow No. 2, and one standard snow plow No. 2, for the Western Division, and two wing elevator snow plows of the same size for the Rome, Watertown & Ogdensburg line. From the Saginaw, Tuscola & Huron Railroad an order has been received for a No. 3 snow plow with air flangers, and from a new road in Maine, the Washington County Railroad, for one No. 4 and one No. 3 plow, with hand flangers. Russell snow plows have also been ordered by the Grand Rapids & Indiana, the Chicago & West Michigan, the Detroit, Grand Rapids & Western, each having ordered a Russell wing elevator snow plow, size No. 2. The plows for the Chicago, West Michigan and the Detroit, Grand Rapids & Western are to have the Russell air flanger attachment and Westinghouse air brakes.

Some time ago Pullman's Palace Car Company built three parlor cars for the Baltimore & Ohio New York trains, and the radical departure from other cars of this character lay in the toilet room for ladies, which was eight feet in length. Recently the same company has built eight new sleepers for the New York-St. Louis line of the B. & O. The cars are finished in vermillion wood, decorated with inlaid marquetry work and the upholstery on the backs and seats is entirely new and different from any heretofore used, being a moquette with a dark green border and a center pattern of bright color. A similar design of ornamentation has been applied to the ceiling, giving the car an arabesque effect. They are also supplied with all the modern appliances, such as wide vestibules, anti-telescoping device, air pressure water system and are lighted with Pintsch gas.

The Sargent Company has three orders for steel castings for 10-inch disappearing gun carriages for the United States Government, one to go to the Rock Island Arsenal, one to the Walker Company at Cleveland, and the other to St. Paul. Our representative happened to see a report upon one of them by the Inspector of the Ordnance Department, U. S. A., in which two specimens showed the following results:

Tensile Strength.	Elongation.	Reduction.
75,050 lbs.	26. %	37.3%
78,450 lbs.	27.5%	40.4%

The second, which showed 40.4 per cent. reduction and 27.5 per cent. elongation, is an average sample of the work of the

foundry. Besides a large amount of ordinary work on hand, two large castings of 16,000 lbs. each are being made for some heavy machinery for E. P. Allis & Co., of Milwaukee. These take an entire heat of a furnace, and show the ability of the concern to handle heavy work. The use of cast steel is extending, and the care exercised in these works gives them an excellent reputation. The orders for the "Diamond S" brake shoes keeps that department busy up to its full capacity, and Mr. W. D. Sargent reports excellent prospects of extensive use of this form of brake shoe in Europe. The general practice in England and on the Continent is to use common cast iron, and during his recent trip abroad he found foreigners interested in the progress that has been made in the development of brake shoes in this country.

OUR DIRECTORY

OF OFFICIAL CHANGES IN NOVEMBER.

Atlantic & Danville.—Col. Henry S. Haines has been appointed Vice-President, with office in New York City.

Bangor & Portland.—Mr. John N. Hoffman has been appointed Purchasing Agent, with office at Bangor, Pa.

Baltimore & Ohio.—Mr. L. Norvell has been appointed Assistant Engineer of Maintenance of Way of the Baltimore & Ohio at Martinsburg, W. Va.

Baltimore & Ohio Southwestern.—Mr. W. M. Greene has accepted the office of Vice-President, with headquarters at Cincinnati, Ohio, succeeding Capt. W. W. Peabody, resigned.

Boyer City & Southeastern.—Mr. Harry J. White has been appointed Master Mechanic and Superintendent of Transportation, with headquarters at Boyer City, Mich.

Chicago & Eastern Illinois.—Mr. Charles Butler has been appointed Master Mechanic, with headquarters at Mokenca, Ill.

Chicago Great Western.—Mr. C. E. Slayton has been appointed Division Master Mechanic, with headquarters at Dubuque, Ia.

Chicago, St. Paul, Minneapolis & Omaha.—Mr. M. L. Sykes has been elected Vice-President and Assistant Secretary, with headquarters at New York.

Choctaw, Oklahoma & Gulf.—Mr. F. W. Valliant has accepted a position with the Engineering Department, with headquarters at Fort Smith, Ark. He was formerly Chief Engineer of the Arkansas & Choctaw.

Detroit & Lima Northern.—Mr. T. M. Downing has been appointed Master Mechanic, with office at Tecumseh, Mich., in place of Mr. J. W. Stokes, resigned.

El Paso & Northeastern.—Mr. H. A. Sumner has been appointed Chief Engineer, in place of Mr. J. L. Campbell.

Fort Worth & Rio Grande.—Mr. T. J. Shellhorn has been appointed Master Mechanic, with office at Fort Worth, Texas, in place of Mr. B. G. Plummer, resigned.

Grand Trunk.—Mr. C. H. Sutherland, Mechanical Engineer, died very suddenly a short time ago.

Grand Trunk.—Mr. W. A. Bell has been appointed Assistant Master Mechanic at Chicago, succeeding Mr. E. D. Jameson, promoted.

Great Northern.—Mr. D. Miller has been appointed Second Vice-President. He was formerly Vice-President and Traffic Manager. Mr. Miller's headquarters will be in St. Paul. Mr. F. E. Ward has been appointed General Superintendent, with headquarters at St. Paul, Minn., in place of Mr. Russell Harding, resigned.

Illinois Central.—Mr. W. B. Baldwin, Master Mechanic at McComb City, Miss., was instantly killed near Arcola, Nov. 5. He was 45 years of age, and had been connected with the road for a number of years.

Iowa Central.—Mr. Robert J. Kimball has been elected President, and Mr. George R. Morse, Vice-President and Treasurer.

Iron Mountain.—Mr. Peter Gable, Master Mechanic at Texarkana, has resigned, and has been succeeded by Travelling Engineer Beck.

Kaslo & Slocan.—Mr. Robert Irving has been elected President, succeeding Mr. D. J. Munn. Mr. George F. Copeland was elected Vice-President and Treasurer, succeeding Mr. A. Guthrie. Mr. James Jeffries was elected Secretary. The duties of the office of Secretary were heretofore performed by Mr. Robert Irving, Traffic Manager.

Manistee & Grand Rapids.—Mr. A. D. Hart has been appointed Superintendent and Master Mechanic, with headquarters at Manistee, Mich., vice Mr. W. H. Herbert, resigned.

Michigan Central R. R.—Mr. S. B. Wright has been appointed Assistant Purchasing Agent.

Munising.—Mr. Robert E. Morrison has been chosen President, with office at Munising, Mich., in place of Mr. D. P. Eels.

New Jersey & New York.—Mr. J. W. Platten has been appointed Assistant Purchasing Agent.

New York, Susquehanna & Western (Erie).—Judge W. J. Lewis, General Manager, has resigned. The duties of the office will be assumed by Captain W. A. May, Superintendent of the Hillside Coal & Iron Co., a mining company operated under the management of the Erie.

Oconee & Western.—Mr. A. F. Dailey has been chosen President. He was formerly General Counsel of the Wrightsville & Tennille.

Oregon Railroad & Navigation Co.—Mr. Henry Pape has been appointed Chief Engineer of the water lines in place of Mr. Reuben Smith, with headquarters at Portland, Ore.

Oregon Short Line.—Mr. W. D. Cornish has been elected President to succeed Mr. Samuel Carr. He was formerly Vice-President of the Union Pacific.

Pennsylvania.—Mr. J. B. Boyer has been appointed Chief Motive Power Clerk, with office at Altoona, vice Mr. B. F. Custer, deceased.

Pittsburg & Lake Erie.—Mr. Carl Zinck, Assistant Supervisor, has been appointed Assistant Engineer of Construction and Maintenance of Way, with headquarters at McKee's Rocks, Pa. Mr. Edwin F. Wendt has been appointed Assistant Engineer in charge of Maintenance of Way and Construction Work on the main line, with headquarters at Pittsburg, Pa.

South Atlantic & Ohio.—A. B. B. Harris, heretofore Acting Superintendent, has been appointed General Superintendent, with headquarters at Bristol, Tenn.

Southern California.—Mr. Paul Morton, Chicago, has been elected Second Vice-President and Mr. E. D. Kenna First Vice-President.

Southern Pacific.—Mr. W. H. Russell, heretofore Traveling Engineer, has been appointed Assistant Master Mechanic, with headquarters at Oakland, Cal.; Mr. J. C. Martin has been appointed Traveling Engineer, succeeding Mr. Russell, with headquarters at Los Angeles, Cal.

St. Louis, Chicago & St. Paul.—Mr. William H. Hale, President, has been appointed Receiver, with office at No. 27 Pine street, New York.

St. Louis, Iron Mountain & Southern.—W. H. Harris, Master Mechanic at De Soto, Mo., has resigned.

St. Louis, Peoria & Northern.—Mr. J. N. Faithorn has been elected President to succeed Mr. William E. Guy.

St. Louis Southwestern.—Mr. Edwin Gould has been chosen President. He was formerly Vice-President, and now succeeds Mr. S. W. Fordyce, who declined a re-election to the office. Mr. Russell Harding, General Superintendent of the Great Northern, has been elected Vice-President.

Union Pacific, Denver & Gulf.—Mr. J. S. Turner has been appointed Superintendent of Motive Power; Mr. B. L. Winchell, heretofore General Passenger and Ticket Agent of the St. Louis & San Francisco, has been appointed Assistant to the President of this reorganized line, with headquarters at Denver.

Wabash.—Mr. Charles H. Kelske has been transferred from Montpelier, O., to Detroit; Mr. George F. Hess, of Fort Wayne, is appointed Master Mechanic at Montpelier; Mr. G. J. Devilbiss is transferred from Andrews to Tilton; Mr. J. L. Flynn is made Foreman of the Andrews shop, and Mr. Charles L. Bond, Master Mechanic at Tilton, Ill., is transferred to Fort Wayne.

Washburn, Bayfield & Iron River.—Mr. Martin Brown has been appointed Master Mechanic, with headquarters at Washburn, Wis.

Washington County.—Mr. H. R. Robinson has been appointed Chief Engineer, with headquarters at Calias, Me. He was formerly Division Engineer at Machias, Me.

Western Maryland.—Mr. H. E. Passmore has been appointed Master Mechanic, with headquarters at Hagerstown, Md.

White Pass & Yukon.—Mr. W. H. Garlock is Master Mechanic, Mr. W. L. Wilson, Purchasing Agent, and Mr. J. W. Young, General Storekeeper. The headquarters are at Skaguay, Alaska.

Wisconsin Central.—Mr. W. Percy has been appointed Master Car Builder, with headquarters at Stevens' Point, Wis., in place of Mr. W. Cormack, resigned.

LICENSES

To be sold in each district for Patent Safety Apparatus for Gauge Glasses adaptable for any kind of steam boiler. United States Patent No. 409,280. Greatest success in Europe under Government control and legalized introduction. First-class technical firms only are invited to correspond with HERREN: LEYMANN & KEIM, Aix La Chapelle, Germany.









CARNEGIE LIBRARY OF PITTSBURGH



3 1812 04296 1012