

Mobile contributing

Wikimania Research Findings

Olga & Alex H
August 2018



WIKIMEDIA
FOUNDATION

Contents

Overview

What's the mobile contributing project?

Research

What have we learned thus far?

Sketches & designs

Some designs based on our research

What's the mobile contribution project?

Per the annual plan, the Reading Web team is currently working on [advanced mobile contributions](#). We aim to make it easier for people to contribute productively to Wikimedia projects on a mobile device by exposing previously unavailable pages in the mobile skin (Minerva). Our goal is to see an increase in edits from the Minerva skin, as well as a stable rate of retention for the feature set itself.

Research

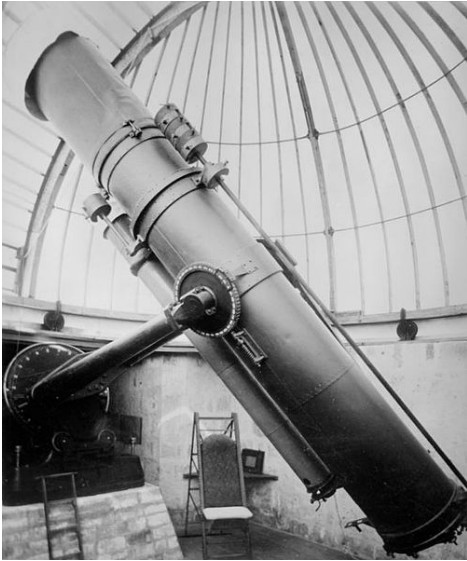

Photo attributions

Phones - Wikimedia Commons, User:Jasonanaggie

Telescope - Wikimedia Commons, User:Nat1

Dog sled - Wikimedia Commons, User:Dodo bird

Wikimania Research

Goals

We used Wikimania as an opportunity to discuss our plan with contributors and do a bit of research.

Research goals:

- 1) Build good faith with contributor community & sign people up for continued engagement
- 2) Collect basic information about current mobile editing practices
- 3) Identify/prioritize key pages/tools for mobile contributing
- 4) Better understand how we might organize the navigation for advanced mobile contributors

Wikimania Research

Process

- Participants were a combination of people who sought us out, and individuals we identified/recruited through casual conversations
- The interviews were conducted in a semi-formal manner (somewhere in between casual conversations about editing and a formal user interview).
- We followed an [interview script](#), although the casual nature of the conversations meant that the interviews tended to vary a bit
 - This included a card ranking activity (pages/tools) and a card sorting activity (nav)
- For the two days before the conference we conducted interviews at our table in the hackathon room
- For the three days of the conference we conducted interviews at our table in the community village

Goal 1

Build good faith with contributor community & sign people up for continued engagement

- People were generally excited about us working on mobile contributions (and working *with us* on mobile contributions)
 - There were several editors who have been editing for a long time on desktop, have never edited on mobile, and seemed unlikely to start. These folks were definitely the minority
- People willingly started watching our project page and were enthusiastic about continuing to engage after Wikimania
- We collected contact information from 30 editors with the understanding that we will reach out to them for continued collaboration

Goal 2

Collect basic information about current mobile editing practices

- Most of the people we talked to do some editing on mobile
 - For some it's a regular thing
- **They (almost always) use the desktop version of the site to edit on mobile**
- For some editors the blockers to editing on mobile have less to do with our product, and more to do with general constraints e.g. difficulty typing on a smartphone
- Editors noted that using the desktop version on their phone is noticeably slower than the m.wiki site
- People generally don't check to see how their edits look when rendered on mobile (despite knowing the majority of reading happens on mobile)

Goal 3

Identify/prioritize key pages/tools for advanced mobile contributing

Out of the many pages and tools editors/contributors use, which ones are most critical to them being able to edit on mobile?

In order to investigate this we did a card ranking activity with participants. Each card was a page or tool that is part of the editing workflows. We allowed people to add other pages/tools if they weren't included.

Talk pages

Help page

Village pump

Admin noticeboard

Recent changes

Pending changes

New pages feed

Related changes

User pages

Contributions

Preferences

Watchlist

What links here

Diff pages

History

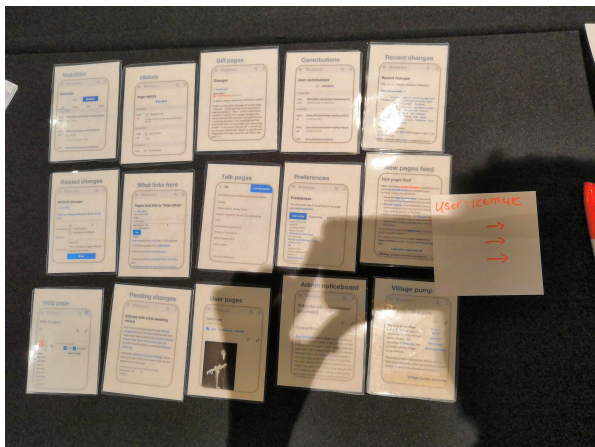
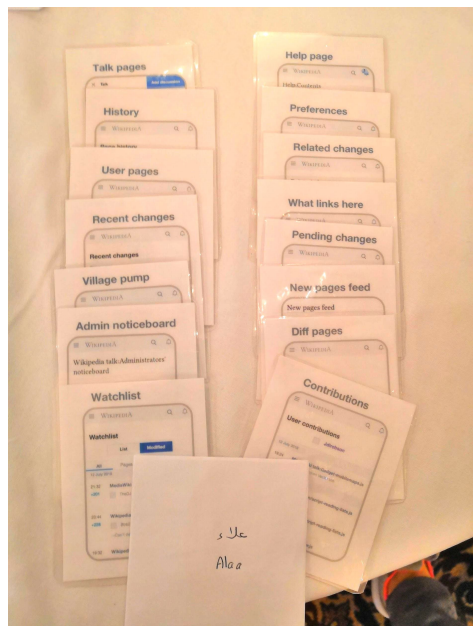
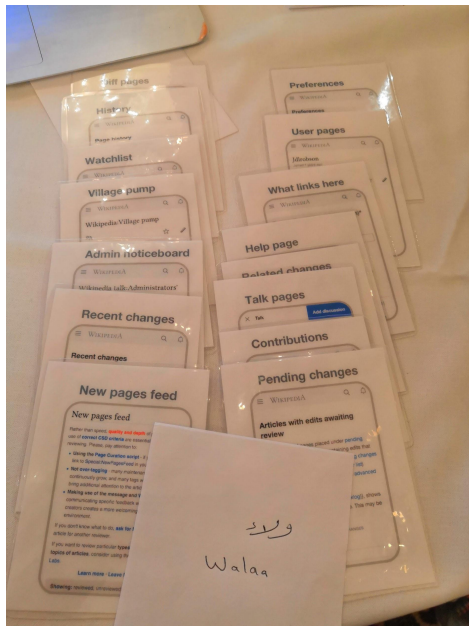
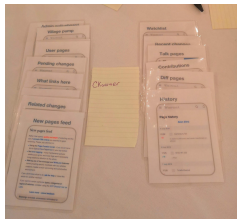
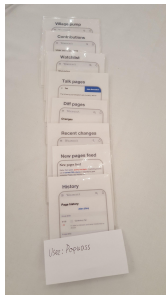
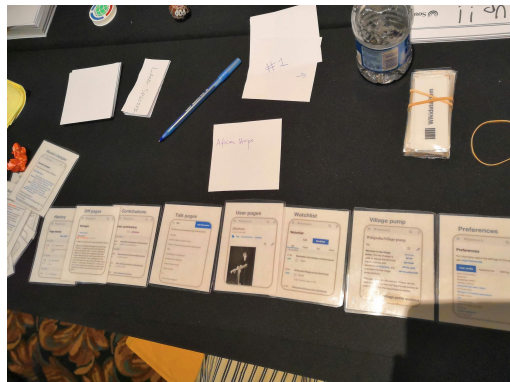
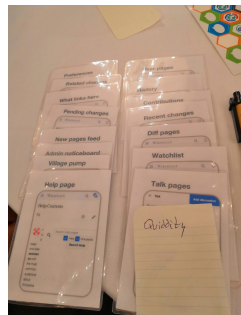
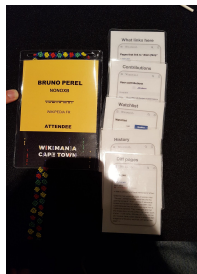
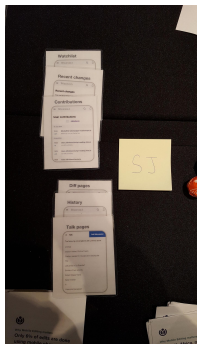
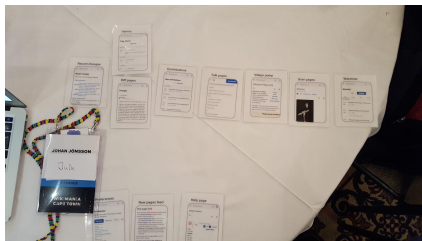

Results

Our sample size was small (30 people, so this is by no means statistically significant) however here are the following pages/tools that consistently were mentioned as being critical to mobile contributing:

- **History**
- **Diffs**
- **Watchlist**
- **Talk**
- **Contributions**
- **Recent changes**

Detailed results from card ranking activity [here](#)

Example workflow/pattern of use

1. Discover

Talk

Watchlist

Notification

Changes feed

DIFF

2. Investigate/gather context

History

Contributions

Talk

3. Take action

Revert

Edit

Flag, comment, etc.

This 3 part workflow, centered around a diff, was described by one of the participants while they were explaining their rankings. They start off by discovering relevant changes (diffs), investigate/gather additional context, then finally take action.

Goal 4

Better understand how we might organize the navigation for advanced mobile contributing

How do editors and contributors navigate around Wikipedia? How can we create a mobile navigation for advanced mode that is conducive to productivity?

In order to investigate this we did a card sorting activity with participants. Each card was a nav item currently in Vector. We allowed people to add other nav items if they weren't included.

Main page	Permalink	Watch
Special pages	Contributions	Languages
Page info	Notices	Print
Talk	Watchlist	Cite page
Featured content	Community portal	Current events
Recent changes	Sandbox	Download PDF
Random	Article	Help
Search	History	Related changes
Your user page	Edit	Beta
Your talk page	Alerts	Log out
Nearby	Wikiadata item	Preferences

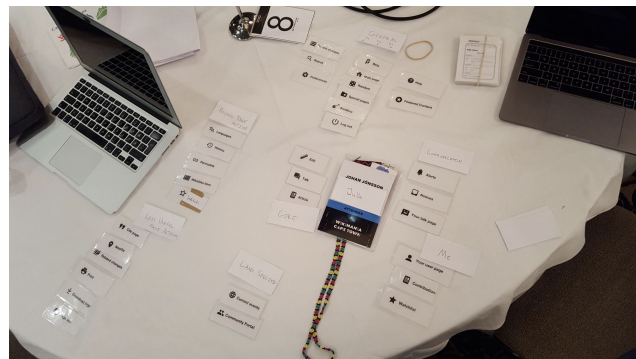

What groupings did people make?

About the page
About the users
Featured
Misc (used, unused)
Don't use

Page actions
User profile
Discovery
Communication
Forum
Editor tools

Page actions (core, useful,
less useful)
Me
General
Communication
Language specific

Article
User
Main

Article (editor, reader specific)
About the user
Wiki on the whole

Commonalities

About the page
About the users

Featured

Misc (used, unused)

Don't use

Page actions

User profile

Discovery

Communication

Forum

Editor tools

Page actions (core, useful,
less useful)

Me

General

Communication

Language specific

Article

User

Main

Article (editor, reader specific)

About the user

Wiki on the whole

- **Page/article stuff**
- **User profile stuff**
- **General content/discovery stuff**

*I think it's interesting how two users separated out Communications, and included the same three items (User's talk page, Notifications, Alerts)

● Page/article stuff

Core

Article

Talk

Edit

History

Secondary

Languages

Wikidata item

Page info

Related changes

Permalink

Watch

Download PDF

Print page

Cite page

What links here

● User profile stuff

Your user page

Watchlist

Contributions

Preferences

Sandbox

Beta

Log out

Communications

Your talk page

Notices

Alerts

● General content/discovery stuff

Main page

Featured content

Random

Nearby

Search

Recent changes

Special pages

Current events

Help

Community portal

As a secondary method to learn more about how we might design the navigation for advanced mode we showed people two prototypes. This was less of a pointed review where we were trying to answer specific questions, and more of a conversational prompt/stimulus.

Overall, users reacted positively to the idea of the expanded navigation while having comments and feedback on specific elements of the prototypes themselves.

Prototype 1

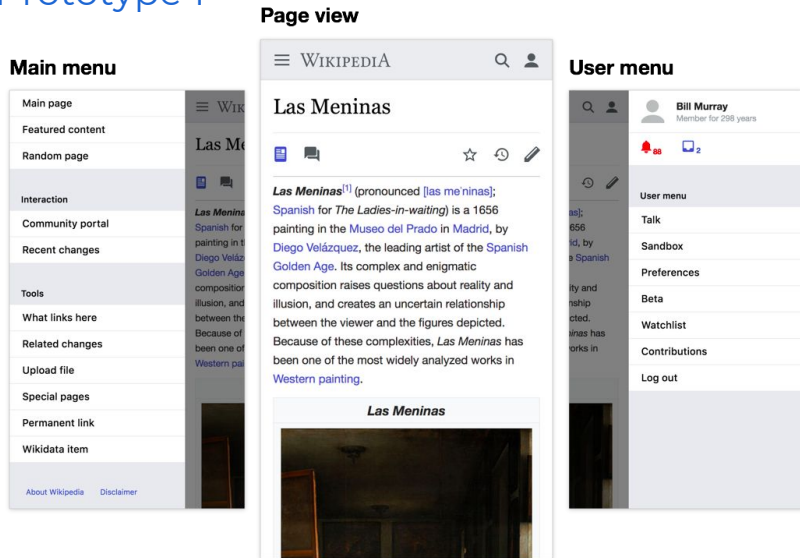

Prototype 2

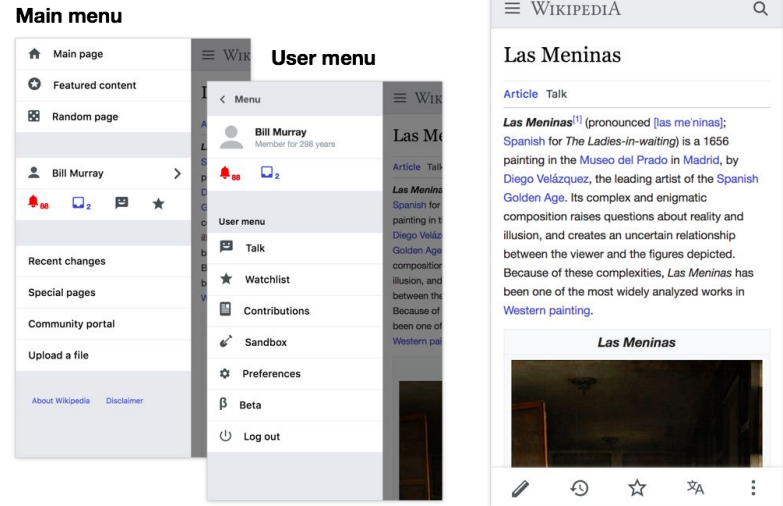

Putting it all together

Page/article (core)

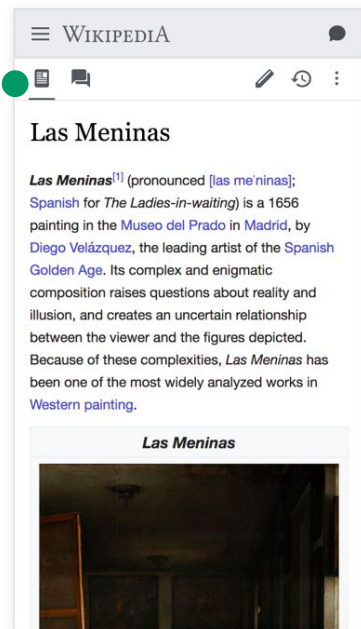

Page/article (secondary)

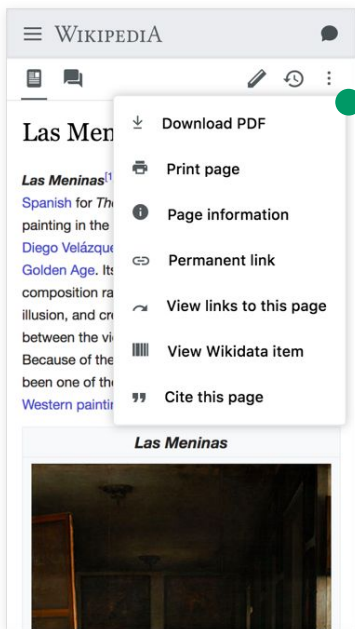

User (core)

General content/discovery

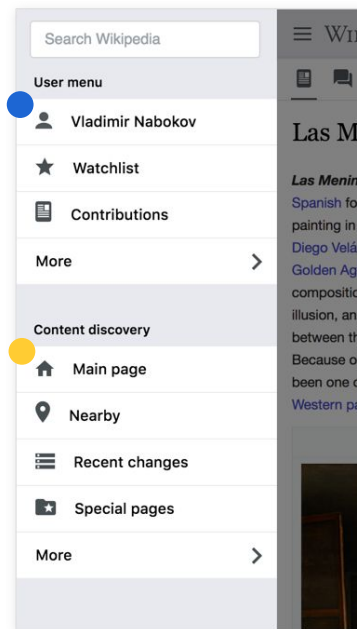

User (communication)

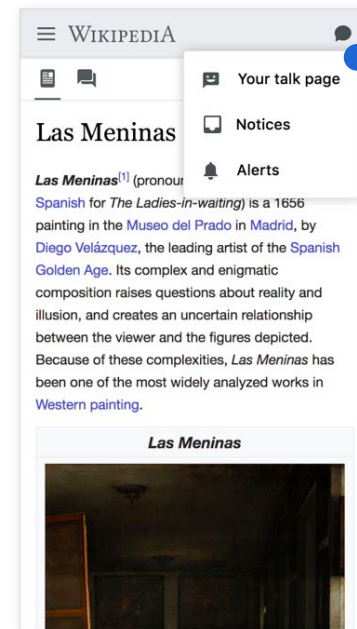

*There are many similarities between this nav and Vector. One of the main differences is the consolidation of Page/article actions, which seems intuitively right and was also confirmed by our nav card sort activity.

*Does a general "Edit" button make sense, or should we stick with section editing?

Sketches & Designs

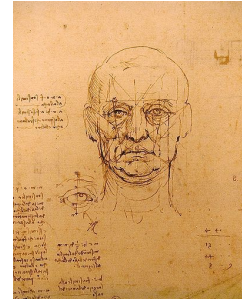
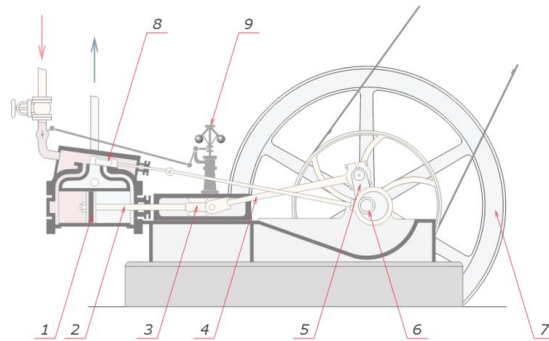

Photo attributions

Pencil - Wikimedia Commons, User:Palnatoke

Steam engine schematic - Wikimedia Commons, User:Panther

Di Vinci sketch - Wikimedia Commons, User:Lviatour



Latest nav prototype

Thanks



WIKIMEDIA
FOUNDATION