





BOTANICAL LIBRARY OF

ANNIE MORRILL SMITH

BROOKLYN, NEW YORK

No. 314



THE AMERICAN

MONTHLY

MICROSCOPICAL JOURNAL:

CONTAINING

CONTRIBUTIONS TO BIOLOGY.

VOLUME XIII.

FOR

1892.

FOUNDED IN 1880, BY ROMYN HITCHCOCK, F. R. M. S.  
PUBLISHED SINCE 1887, BY CHAS. W. SMILEY,  
WASHINGTON, D. C.



## LIST OF ILLUSTRATIONS.

	<i>Page.</i>
Stratton's Illuminator (plate).....	1
Zentmayer's Dissecting Microscope (plate).....	1
Koch's and Woltz' Microscope Lamp (figure).....	2
Taylor's Freezing Microtome (plate).....	25
Gonatozygon aculeatum (figure).....	29
Apparatus for Controlling Living Organisms (figure).....	31
Camera for Micro-photography (figure).....	39
A Nice Sterilizer (figure).....	39
Van Heurck's Large Microscope (plate).....	49
Rhizopod. Clathrulina Elegans (figure).....	53
Apparatus for Biological Examination of Water (figure).....	55
Funnel (figure).....	56
Plans and Sections of Slides and Cover-glass (figure).....	58
Edinger's Drawing Apparatus (figure).....	66
Durkee's Electric Illuminator (figure).....	67
Beck's New Bacteriological Star Microscope (plate).....	81
Abbe Illuminator (figure).....	83
Camera lucida (figure).....	85
An All-around Microscope (figure).....	91
Sayre's Pocket Microscope (figure).....	95
Biological Study of the Potato (plate).....	105
Bausch & Lomb's New Microscope (plate).....	129
Continuity of Protoplasm (figure).....	131
Some New Desmids (plate).....	153
Lane-Sear Microscope Lamp (figure).....	165
Box for Slides (figure).....	166
Pressureless Mounting-Clip (figure).....	166
Radiolaria (plate).....	177
A Convenient Sterilizer (figure).....	192
Zentmayer's American-Continental Microscope (figure).....	194
Tripod Edinburgh Student's Microscope (plate).....	201
Protozoa (plate).....	225
Index of Refraction (figure).....	226
Refractometer (figure).....	228
Bertrand's Refractometer (figure).....	228
Potato-Section Cutter (figure).....	244
Radiolaria (plate).....	249
Lighton's Analyzing Eye-piece (figure).....	260
Rotifers (plate).....	273
A Cheap Microscope Lamp (figure).....	287







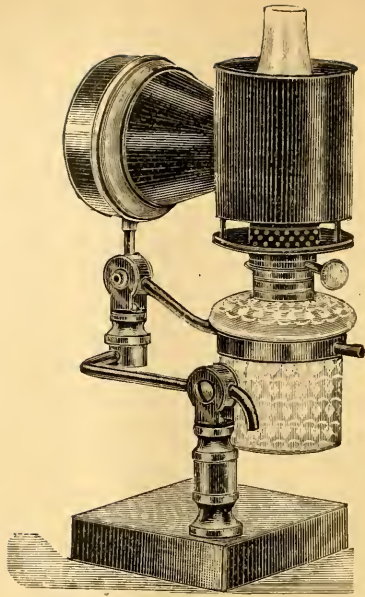

FIG. I.—STRATTON'S ILLUMINATOR.

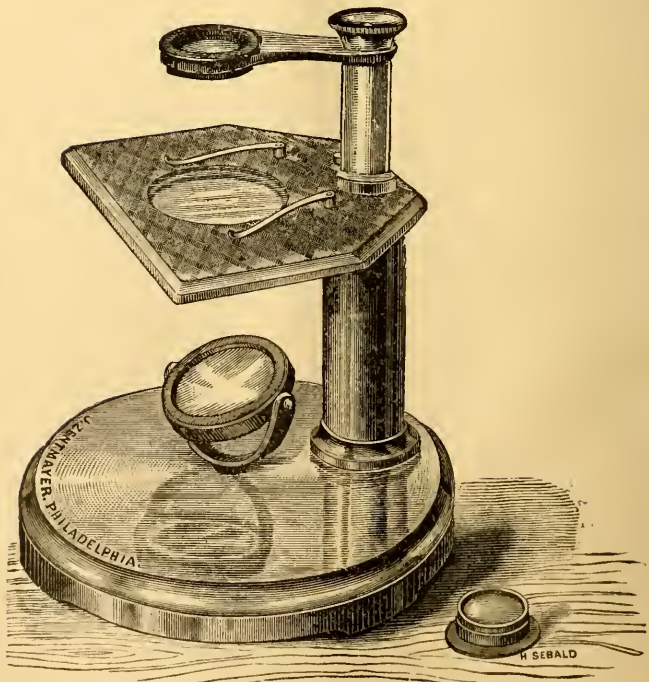

FIG. II.—ZENTMAYER'S DISSECTING MICROSCOPE.

# THE AMERICAN MONTHLY MICROSCOPICAL JOURNAL.



VOL. XIII.

JANUARY, 1892.

No. 1.

### CONTENTS.

<p>Some New Apparatus—(Illustrated) 1</p> <p>Observations on Staining the Flagella on Motile Bacteria. —MOORE. 3</p> <p>Introduction to Elementary Biology. —OSBORN - - - - - 9</p> <p>Rotifer Notes.—KELLICOTT - - - - 12</p> <p>Defects in Certain European Grapho Prisms.—KNOTT - - - - - 12</p> <p>RECREATIVE MICROSCOPY.—Silver Crystals - - - - - 13</p> <p>EDITORIAL.—The Needs of American Microscopy - - - - - 14</p> <p>MICROSCOPICAL APPARATUS.—A New Polarizer. Glass for Immersion Oil. Making Lenses. Collecting Sediment for Examination - 15</p> <p>MICROSCOPICAL MANIPULATION.—A New Mounting Fluid. Crustacean Eyes. Dried Algæ. Resolution of Amphipleura Pellucida. 16</p> <p>BIOLOGICAL NOTES.—Sex Determined by Temperature. Life After Desiccation. Malaria parasites. The Radish. Hepatica triloba. Jump-</p>	<p>ing Seeds. Strength of Vegetable Growth. Fermentation of Bread. Growth of Sea Weeds. Sugar-Cane Diseases. An Elm Parasite. Life in Great Salt Lake. A Pink Micro-Organism - - - - - 17</p> <p>MEDICAL MICROSCOPY.—A Troublesome Cotton Seed. Purulent Arthritis without Micro-organisms. The Bacillus of Typhoid. Influenza. Germs of Diphtheria. 19</p> <p>MICROSCOPICAL NEWS.—The Microscopical Exhibition at Antwerp. Sharp Practice. Diatom Notes - 20</p> <p>MICROSCOPICAL SOCIETIES.—San Francisco, Cal. Washington, D. C. Austin, Texas. Royal Microscopical Society, London. Microscopical Club, St. Louis, Mo. Montreal Microscopical Society - 21</p> <p>NOTICES OF BOOKS.—Ball. Huling. Bell - - - - - 24</p> <p>WANT, SALE, AND EXCHANGE NOTICES - - - - - COVER.</p>
---------------------------------------------------------------------------------------------------------------------------------------------------------------------------------------------------------------------------------------------------------------------------------------------------------------------------------------------------------------------------------------------------------------------------------------------------------------------------------------------------------------------------------------------------------------------------------------------------------------------------------------------------------------------------------------------------------------------------------------------------------------------------------------------------------------------------------------	--------------------------------------------------------------------------------------------------------------------------------------------------------------------------------------------------------------------------------------------------------------------------------------------------------------------------------------------------------------------------------------------------------------------------------------------------------------------------------------------------------------------------------------------------------------------------------------------------------------------------------------------------------------------------------------------------------------------------------------------------------------------------------------

## Some New Apparatus.

### I.—STRATTON'S ILLUMINATOR.

(See frontispiece, figure I.)

This lamp, supported by nickel-plated rods rising from a heavy base, and having an oil tank of ornamental glass, presents a beautiful appearance; and being packed in a nice box of the general shape of a microscope box, constitutes an excellent addition to the paraphernalia of a microscopist. The supporting rods are connected by stiff joints, which cause the lamp to remain in any position in which it has been placed, and the possible positions of elevation or of obliquity are such as to give light in any manner desired.

The oil tank can be rotated in the holder, thus turning the edge or the broadside of the flame towards the microscope as necessity may require. The thick glass chimney as well as the flame is concealed by the metallic hood, well blackened, while a projection on the side of the hood directs the rays of light towards the bull's-eye. The latter, of unusual size (3 inches dia.), is supported by an independent support. The advantage of this is that the entire illuminating apparatus may be disconnected from the bull's-eye or the light directed otherwise than through the bull's-eye if more general illumination is desired. The

light from the flame is passed through a ground glass or blue glass at pleasure, and before reaching the bull's-eye. Strong or faint light, direct or oblique light, can all be had easily and without changing any adjustment of the microscope. The half-inch wick gives a very good flame, kerosene being used to burn. The arrangements for draft and for cleaning are good. More and better effects can be gotten with this lamp than with any other that has come to our notice. The placing of the lamp on the market will be duly advertised at the proper time.

### II.—ZENTMAYER'S DISSECTING MICROSCOPE.

(See frontispiece, figure II.)

This instrument was made primarily for botanical work. It has a circular base 5 inches in diameter and is made of polished brass. A stout pillar rises about 6 inches on one side, to which are attached a broad stage (4 x 5 in.) and a jointed arm for carrying the lenses. A plane mirror is adjusted to the base beneath the stage. The stage carries spring clips, which are easily removed to make room for a glass plate which fits the well of the stage. With the instrument come two lenses, 1 inch and  $\frac{3}{4}$  inch, which may be combined to secure a  $\frac{2}{3}$  inch focus. The plan of this microscope was suggested by Prof. J. T. Rothrock, of the University of Pennsylvania, and it is used in his botanical classes. The cut is one-half the natural size. The whole is packed in a neat walnut case with drawer and handle. The price is eight dollars.

### III.—KOCH'S AND WOLZ' MICROSCOPE LAMP.

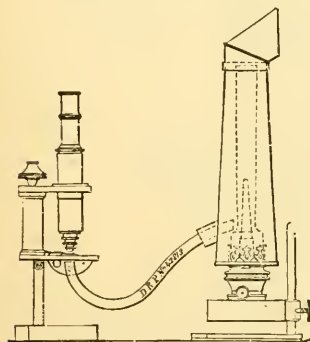

This lamp consists of a plain, round-burner, kerosene lamp, mounted on a stand so that it can be raised and lowered; it is covered with a chimney of japanned sheet-iron with two tubulations on a level with the most luminous part of the flame, each holding a solid glass rod of peculiar curvature. The light entering one end of the glass rod is transmitted through its full length, without radiation through the sides of the rod, and it emanates at the other end diffused and soft with almost undiminished intensity. A double bent rod is intended for illuminating transparent objects from beneath the stage; the other, with but a single bend, is used for illumination of opaque bodies from above.

The following are some of the advantages claimed for this lamp:

It can be used in a dark room or at night, making the observer independent of daylight. The light can be brought very near to the object, and it is diffused and uniform. This is especially the case where the object is imbedded in or forms cavities. Shadows, which cause error where a high magnifying power is used, are entirely avoided. The lamp is covered by the metallic chimney, and as the rod transmits no rays laterally, the eye is not annoyed by any direct light. The lamp is complete in itself, and makes other auxiliaries, such as mirrors, condensing lenses, etc., superfluous; or these may be rendered more efficient by its aid. It therefore forms a useful adjunct to the plainest or the most complicated microscope. It is very simple in construction, and easily adjusted, requiring no particular care or skill.

## Observations on Staining the Flagella on Motile Bacteria.\*

By VERANUS A. MOORE, M. D.,

ASSISTANT IN THE LABORATORY OF THE BUREAU OF ANIMAL INDUSTRY, DEPARTMENT OF AGRICULTURE,  
WASHINGTON, D. C.

From a microscopical stand point no branch of the investigation of micro-organisms is, perhaps, more interesting than the study of the flagella on motile bacteria. As their discovery has shown the structure of these organisms to be much more complex than was before supposed, the determination of the number and arrangement of these minute appendages with which the various species are provided is important, not only from the knowledge thus derived of their structure, but also as a possible aid in the differentiation of closely allied species.

The fact that certain motile bacteria were provided with flagella was made known early in the history of Bacteriology, but there seems to have been no method devised until a comparatively recent time by which they could be carefully studied or by which their presence on other motile forms could be shown. The difficulty in detecting the flagella on bacteria in a fresh condition is well illustrated by the investigations of Dallinger and Drysdale, who saw only a few of these appendages in a preparation of *Bacterium termo* after an incessant examination of nearly five hours. Although our instruments and methods have been much improved since that time I believe that at the present time the satisfactory demonstration of flagella on living bacteria is one of the most difficult tasks known to microscopists.

It is through the development of the staining processes that the demonstration of these appendages on the great majority of motile bacteria has been made possible, and, in many cases, comparatively simple. As early as 1877 Koch succeeded in staining the flagella on a certain number of the larger saprophytic bacteria. Since then other methods have been devised which are applicable to the smaller and also the pathogenic forms. By the aid of these methods the flagella have become recognized as forming a part in the morphology of motile bacteria. This fact is important, as any difference found to be constant between the characters of the flagella of two bacilli will be as significant in differentiating them, the one from the other, as the presence or absence of spores or a difference in the form or size of the bodies of the germs themselves. It is for their differential value that a knowledge of the flagella may render valuable services to the practical bacteriologist.

In 1889 Loeffler published a method in which he introduced the principle of a mordant in staining the flagella and cilia on micro-organisms. By subjecting the preparations to the action of a mordant before they were brought into the staining fluid he succeeded in staining the flagella on a considerable number of bacteria. There were, however, many motile forms on which these appendages could not be detected. This fact led to further investigations, which resulted in the discovery of the principle "that the alkali producing organisms required an acid mordant and that the acid producing organisms required an alkaline mordant." This was based upon the results obtained by Petruschky,† who had found that a large number of bacteria would convert the reaction of a neutral medium (liquid) into either an acid or an alkaline one during their multiplication.

\* Read before the American Society of Microscopists, August, 1891.

† Centralblatt f. Bakteriologie u. Parasitenkunde, Bd. vi (1889), p. 625.

The importance of Loeffler's method in the acquisition of our knowledge of the flagella of bacteria has prompted me to present it here, in a form as condensed as possible, both for its own value and as a basis for my subsequent remarks. The formulæ for the preparation of the mordant and staining fluid, together with the details in their application, are as follows:

(1) *The Mordant*.—To 10 cc. of a 20 per cent. aqueous solution of tannin 5 cc. of a cold saturated solution of the sulphate of iron and 1 cc. of an aqueous or alcoholic solution of fuchsin, methyl-violet, or "Wollschwarzlösung" are added. The fuchsin is especially recommended.

The foregoing solution is to be regarded as the standard or stock solution to be used, and one which is successfully employed in staining the flagella of certain microbes, but for others the addition of an acid or alkali is necessary. Thus for the *comma bacillus* it is necessary to add to the 16 cc. of mordant  $\frac{1}{2}$  to 1 drop of a solution of sulphuric acid, equivalent to a 1 per cent. solution of sodium hydrate. For the *Typhoid bacillus* 1 cc. of a 1 per cent. solution of sodium hydrate must be added to the 16 cc. of mordant. By first determining whether the germ in question is an alkali or acid producing organism, the necessary quantity of the acid or alkaline solution to be added to the mordant can easily be determined by actual experiment.

(2) *The Staining Fluid*.—The staining fluid consists of a saturated solution of crystal fuchsin in the ordinary aniline water. As the aniline water is very nearly neutral a saturated solution of fuchsin in it is sufficient. Better results may possibly be obtained by adding to this as much of a 1 to 1000 solution of sodium hydrate as it is necessary to bring it almost to a point of precipitation.

Cover-glass preparations should be made of the bacteria to be studied in such a manner as to avoid all albuminous material. This is best accomplished by transferring a very small quantity of the growth from an agar or gelatine culture to a drop of sterile water on a cover-glass and thoroughly mixing; a small quantity of this is conveyed to a second cover-glass in a like manner; and again from the second a third preparation is made. By this treatment the albuminous substance is sufficiently diluted and the bacteria are isolated in an aqueous medium. The preparation is allowed to dry in the air. Sterilized hydrant water is preferred to distilled water for diluting the culture. It is of the utmost importance that the cover-glass should be free from all impurities. The film on the cover-glass is fixed by heat, but care must be taken not to overheat the preparation. The desired temperature can be obtained by holding the cover between the thumb and index finger over the flame, instead of passing it through the flame by means of forceps. By this method overheating is avoided. After heating, the film on the cover-glass is covered with the mordant and held over a flame until steam is given off. It is then removed, and after  $\frac{1}{2}$  to 1 minute the cover is rinsed in water, then in absolute alcohol, and again in water, until the mordant is completely removed. Care must be taken to remove all traces of the mordant from the cover-glass, as it would form, if present, a very troublesome precipitate with the staining fluid. The film is then covered with a few drops of the staining solution and the preparation again heated until the solution begins to vaporize. It is then removed from the flame, and after allowing the stain to act for about one minute, the cover is washed in a stream of water. The preparation can be examined immediately in water or allowed to dry and be mounted in balsam. The bacteria, with their flagella, should be deeply stained, resting upon a colorless background if they are distributed in a purely aqueous substance, but if albumen is present they are surrounded by a uniformly feebly stained medium, the intensity of which depends upon the quantity of albumen present.

By the use of this method the flagella have been stained on not only a large number of saprophytic, but also on all of the known motile pathogenic bacteria. Unfortunately, the results usually obtained by this process are not satisfactory for the differential purposes suggested in a previous paragraph. The difficulty is not in simply demonstrating their presence, but in the inability to determine the number and arrange-

ment of these appendages on the individual bacteria. In all of the preparations that I have examined, that had been stained by this method, there were a large number of bacilli which exhibited no flagella, while on the others the number was variable; but lying between the bacilli were a greater or less number of flagella that had become detached from the bodies of the germs, presumably during the process of preparation. This is especially prominent in preparations of bacteria that are provided with a considerable number of these appendages, such, for example, as the hog cholera and typhoid bacilli. This fact renders it difficult, if not impossible, to determine the number of flagella with which the individual bacteria of a given species are provided.

Notwithstanding this difficulty which I have met, the method has given such satisfactory results in the hands of A. Messea, an Italian investigator, that he has proposed a systematic classification of bacteria based upon the number and arrangement of the flagella. This classification is as follows:

I. GYMNOBACTERIA.

- |                    |                  |                 |
|--------------------|------------------|-----------------|
| II. TRICHOBACTERIA | } 1. Monotricha. | 3. Amphitricha. |
|                    |                  | 2. Lophotricha. |

The *Monotricha* have one flagellum at one pole of the bacillus (*Bacillus pyocyamus*). The *Lophotricha* have a tuft or bunch of flagella at one pole of the bacillus (*Bacillus of blue milk*). The *Amphitricha* have a flagellum at each pole (*Spirillum volutans*). The *Peritricha* are provided with rows of flagella (*Bacillus typhosus*).

Kruse,\* in a review of Messea's article, says that this classification can have only a secondary value. It is evident that it would conflict very seriously with the natural grouping of the Schizomycetes, as, for example, the *monotricha* would include bacilli, spirilla and at least one micrococcus. (The motile micrococcus described by Ali-Cohen.)

In order to find some process by which I could determine more definitely the minuter details respecting the number, size, and arrangement of the flagella on especially the hog cholera and typhoid bacilli, I have made a considerable number of tests with Loeffler's and other methods † and with various modifications in both the preparation of the solutions used and in the technique of their application. The result of this experimental work has been very largely negative, but the careful testing of each slip in the various processes, especially that of Loeffler, has been productive in revealing a few facts which are deemed worthy of notice. Some of these have suggested certain slight modifications in the technique of Loeffler's process which promise to be of considerable value in the further study of these structures. As his method has already been quoted, I shall refer only to those sections of it for which modifications are suggested or which, for other reasons, are deemed worthy of special remark. These are as follows:

(1) *The distribution of the bacteria on the cover-glass.*—It is of the utmost importance that the bacteria are properly isolated in the preparation. This can be accomplished very satisfactorily by the following process: The cover-glasses, after being *thoroughly* cleaned, are

\* Centralblatt f. Bakteriologie u. Parasitenkunde, Bd. ix (1891), p. 107.

† Frenkmann's are the only methods, other than Loeffler's, that I have found to be of any special value. They involve, however, the same principles as those given by Loeffler, and consequently need not be discussed here. For reference and titles of the various articles on the demonstration of the flagella on motile bacteria see Bibliography.

spread on a level tray. On each cover-glass is placed, by means of a flamed pipette, a moderately large drop of sterile water (distilled or hydrant). This will spread over the entire surface of the cover if it has been properly cleaned. The end of a flamed platinum wire is very gently touched to the surface growth of an agar or gelatine culture of the germ in question, after which it is very carefully immersed two or three times in as many places in the water on each cover-glass. A sufficient number of bacteria will adhere to the end of the wire to make from four to ten preparations. The cover-glasses are then placed in an incubator at a temperature of about  $36^{\circ}$  C., where they are allowed to remain until the water is evaporated.

Many of the bacteria by means of their power of locomotion will become separated from the clump of germs introduced by the wire, and will be found on the drying of the preparation to be distributed very satisfactorily around these centers. This natural separation of the bacteria prevents the breaking off of the flagella by stirring or other artificial means employed in securing the necessary distribution and isolation. In this manner I have isolated the bacteria in a preparation so that in many fields not more than a score of germs could be seen, and the excellent condition of their flagella warrant my recommending this method of preparation. The fact that the bacteria are properly isolated over only a small portion of the preparation is not necessarily an objection. Our hopes, however, are not yet fully realized, for there will generally be a few, often many, detached flagella lying between the bacteria, some of which are partially or wholly deprived of their appendages. I have frequently observed clumps of flagella which gave the appearance of those belonging to an individual germ, the body of which had disappeared. As these were found in preparations made from old cultures, they suggest the possibility that the body of the germ is first to degenerate, or else that through some physiological process the flagella are detached from the bodies of the bacteria after a certain age is attained. These hypotheses are strengthened somewhat by the fact that in older cultures there appear to be a greater number of detached flagella.

(2) *The Composition of the Mordant.*—The mordant recommended by Loeffler seems to be the most satisfactory of any thus far suggested for general use. I have found, however, that a mordant which contains only 10 per cent. tannic acid can occasionally be used with advantage. It can be more easily and thoroughly removed from the specimen, and consequently the formation of a troublesome precipitate with the staining fluid occurs less frequently. It was found that with the *hog cholera bacillus* it gave equally as good results as the one containing 20 per cent. tannin; with the *typhoid bacillus* it was not so satisfactory, and with a *water bacillus* a 20 per cent. tannin solution in the mordant was necessary to secure the staining of the flagella. From a limited number of experiments it seems quite probable that a variation in the quantity of the tannic acid in the mordant may be of much service in staining the flagella on certain bacteria where difficulties are experienced with the use of the mordant prepared after Loeffler's formulæ. Although I have tried a considerable number of the "fixing agents," I have thus far been unable to stain the flagella with the use of any mordant not containing tannic acid.

In applying the mordant I have met with better results by allowing



it to act from two to three minutes. A convenient method of heating the mordant on the cover-glass is to pass it several times through the lower portion of the flame, which heats it sufficiently and prevents spattering. A safer method is to heat the preparation for the required time in a cover-glass containing the mordant.

The heating of the cover-glass to fix the film is also an important condition in the success of the operation. Loeffler's method has the objection that it is difficult to heat the preparations uniformly. I have employed a hot-air chamber for this purpose, and after a series of experiments varying in temperature from 90 to 180° C. and in duration from one-fourth to five minutes, have found that I could obtain the best results by heating the preparations for one minute at a temperature of about 125° C. Little if any difference was noticed in preparations heated at a temperature varying from 120-140° C.

(3) *The Reaction of the Mordant.*—Experiments have shown that the statement made by Loeffler, that an alkali producing organism required an acid mordant and an acid producing organism an alkaline mordant need not be taken in a very strict sense. This is illustrated with the hog cholera bacillus. As it is an alkali producing germ, it would be necessary, according to Loeffler's statement, to add a certain quantity of the acid solution to the mordant in order to stain its flagella. Dr. Theobald Smith stained the flagella on this bacillus by the use of the neutral or standard mordant.\* Further investigation has shown that its flagella can be stained by the use of the mordant containing a variable quantity of either the acid or sodium solution, good results being obtained when as much as 3 cc. of either solution was added to the 16 cc. of the mordant. It is better to add the sodium solution just before the mordant is to be used. I have also found that the flagella on the typhoid bacillus, an acid producing germ, can be stained by the use of either the acid or alkaline mordant. This deviation from Loeffler's results with the typhoid bacillus may possibly be due to the age of the germ, as the one I used had been preserved, by means of subcultures, for several years. The same range in the reaction of the mordant was found to be applicable to a few other bacteria.

(4) *The Staining Fluid.*—I have found that carbol fuchsin (10 cc. of a saturated alcoholic solution of fuchsin, 100 cc. of a 5 per cent. solution of carbolic acid) gives equally as good, if not better, results than the aniline water fuchsin recommended by Loeffler. It also has the advantage that it can be kept for a much longer time, and, consequently, is ready for use at any moment. It has a less tendency to form a precipitate with any trace of the mordant that might be left on the cover. I have also stained the flagella very nicely with Loeffler's alkaline methylene blue.

(5) *The Age of the Culture to be Used.*—A careful examination of the growth from cultures of certain bacteria shows that the flagella can be stained on these germs from cultures varying in age from 20 hours to several weeks. For simply demonstrating their presence any aged culture, within the limits mentioned, can be used. In old cultures the flagella are more broken, and a larger number of detached appendages

\* Dr. Smith pointed out that the reaction of the culture liquid with some bacteria may be either acid or alkaline, according as glucose or other sugars are present or absent. These undergo fermentation with the formation of acids. In liquids free from sugars the reaction becomes speedily alkaline. Petruschky's classification of bacteria as acid and alkali producing is thus shown to depend largely on the composition of the culture medium.

are observed. I have obtained my best results with a culture about two days old. The surface of agar seems preferable to gelatine for cultivating bacteria for this purpose.

In testing the various methods and their modifications I have stained the flagella on a considerable number of bacteria, among which I will mention a large motile bacillus quite common in Potomac water, the *Bacillus fluorescens liquefaciens*, and the *Bacillus coli communis*. The last of these, like the *Typhoid bacillus*, is provided with rings of flagella, and consequently belongs to the *Peritricha*. The flagella on each of these species have been stained by the use of both an alkaline and an acid mordant.

Although a large amount of work has been done to develop satisfactory methods for staining the flagella on motile bacteria, there seem to be many conditions that are not yet fully understood. These must be carefully worked out by actual experiment before we will be able to determine accurately the specific character of the flagella on the different species of bacteria.

No flagella have been found on the swine plague and other non-motile bacteria, although a very large number of specimens have been stained by the same methods that I have successfully employed with the motile forms. This, together with the fact that with certain motile bacteria at least a few flagella can be seen in every stained preparation, eliminates from the writer's mind the doubt that has occasionally been expressed, that the long wavy or spiral filaments seen to radiate from the bacteria or lying between them do not belong to the germs with which they are associated.

I am indebted to Dr. Theobald Smith for suggestions which he has offered from time to time during the prosecution of this work.

#### BIBLIOGRAPHY.

1. Cohn, F. Untersuchungen über Bacterien. *Beiträge zur Biologie der Pflanzen*. Bd. I (1872), p. 126.
2. Dallinger, W. H., and Drysdale, J. J. On the existence of Flagella in Bacterium Termo. *The Monthly Microscopical Journal* (London). Vol. xiv (1875), p. 105.
3. Dallinger, W. H. On the Measurement of the Diameter of the Flagella of Bacterium Termo. *Four. of the Royal Mic. Society*. Vol. i (1878), p. 169.
4. Koch, Robert. Untersuchungen über Bacterien. *Beiträge zur Biologie der Pflanzen*. Bd. II (1877), p. 416.
5. Neuhäuss, R. Ueber die Gisseln an den Bacillen der Asiatischen Cholera. *Centralblatt f. Bakteriologie u. Parasitenkunde*. Bd. V (1889), p. 81.
6. Loeffler, F. Ein neue Methode zum Färben der Mikro-organismen im besonderen ihren Wimperhare und Geißeln. *Ibid.* Bd. VI (1889), p. 209.
7. Loeffler, F. Weitere Untersuchungen über die Beizung und Färbung der Geißeln bei den Bakterien. *Ibid.* Bd. VII (1890), p. 625.
8. Trenkmann, Dr. Die Färbung der Geißeln von Spirillen und Bacillen. *Ibid.* Bd. VI (1889), p. 433.
8. Trenkmann, Dr. Die Färbung der Geißeln von Spirillen und Bacillen. *Ibid.* Bd. VIII (1890), p. 385.
10. Dowdeswell, G. F. Note sur les Flagella der microbe der Choléra. *Annales de Micrographie*. T. II (1890), p. 367.
11. Smith, Theobald. Einige Bemerkungen über Säure und Alkalibildung bei Bakterien. *Centralblatt f. Bakteriologie u. Parasitenkunde*. Bd. VIII (1890), p. 389.
12. Moore, V. A. A review of the methods of Demonstrating the Flagella on

Motile Bacteria with special reference to the Staining Processes. *American Monthly Microscopical Journal* (1891), p. 15.

13. *Messea, A.* Contribuzione allo studio delle Ciglia dei batterii e proposta di una classificazione. *Rivista d'igiene e sanita pubblica.* No. 14 (1889), p. 513.

## Introduction to Elementary Biology.

BY HENRY L. OSBORN,

HAMLIN, MINN.

### PART VII.—A SPECIFIC LIFE HISTORY CONSIDERED BIOLOGICALLY.— THE FROG.

(Continued from p. 243, vol. xii.)

We have now seen that the skin and the lining of the mouth of the frog present in their structure and actions as at present understood no conditions which are absolutely unique and unlike the structure and actions to be found among the protozoa. Undoubtedly the functions of these various cells are more complex than we have had time to indicate; thus the ciliated cell has all the ordinary work of cell life and the work of moving cilia besides, but it seems enough to confine our attention to the special functions of the cells in the present sketch, it being understood, however, that we could readily trace in all the activities parallel ones in the protozoa. We see that the pigment cells specialize two powers—metabolism for the production of pigment, and motion for color changes; while the ciliated cell specializes the power of motion in another way.

The power of motion is further specialized in two ways in the frog in cells of the true "muscular tissue." In *Amœba* the contractility is not increased in a definite manner over certain tracks, as it were, which from habit and inheritance become easy and very readily operated on. In the stem of *Vorticella* the muscular fibre acts quickly and definitely. Presumably its action is helped to be so very quick in response and vigorous from the effects of use, for we should expect practice to improve here as elsewhere. If in the frog masses of elongate cells, whose substance is being constantly used for contractions, are so placed that the shortening can take place simultaneously and all in one direction, their actions can be summated into a pull of an extent determined by the number of the cells, in part at least. It is in this way only that we can understand the anatomy and physiology of frog's muscle, striped or unstriped. We have a good view of the unstriped muscle in some of the small arteries, as, for instance, those of the mesentery, when they can be prepared very readily for examination by first staining with borax-carmine, then mounting in balsam or glycerine. The small artery is seen to be clasped by rows of spindle-shaped cells, involuntary muscle cells, which wrap themselves across the artery. These cells, if they are stimulated by nerve stimuli must shorten and broaden their shape, and in shortening they must narrow the circle of whose arc they form a major part; so all the cells working in unison in a large area upon the bores of the small arteries, the capacity of the area for blood is lessened and the part loses blood, or, as we say, becomes pale. In this case it is the muscular coat of the artery which is at work, but this, to mean anything biologic, must be equal to saying that the spindle-shaped cells of tissue which have specialized the power of contractility

have all contracted. In like manner the muscular coat of the small intestine causes the peristaltic actions, because the circularly-placed cells contract in regular succession from front to back, pushing the contents along before the progressing constriction, and the longitudinally-placed cells, by their contraction after the circular ones, draw the constricted part to its previous larger diameter.

A person might ask why the muscles should do this; how are they advantaged? Now, in the first place, we should answer that we are not sure that all cells must be advantaged in the body as a whole, though it is not at all sure that any are not; and in the second place, we would say that these cells in return for the work they do are abundantly supplied with food; for innumerable capillary blood-vessels keep these cells constantly supplied with food and oxygen, and carry away their waste products. To be sure their independence is gone, and they are held in subjection like galley-slaves and must work when the order comes, but in this respect they are not worse off than people in other societies. They have their periods of rest and are not in danger of starvation if they don't happen to find food. It seems reasonable, then, to regard the unstriped muscle cell as being benefitted by its position in the colony, as well as being a helper in the colony as a whole.

The striped muscle tissue is capable of being regarded in the same way. Here the cells are less evident, and we have to go back to their history and trace their development to find them, for they are peculiarly modified. Single elongate cells\* multiply the nuclei remaining in one family and surrounded by one envelope, the sarcolemma. The protoplasm of the cells, besides surrounding the nuclei, spreads out in the form of a fine network in which lies the peculiar contractile substance, which has a very perfectly arranged structure and is capable of very quick and definite performance. The muscle tissue is made up of fibres which are thus derived from cells, and the contractile substance is a special substance made by the general protoplasm and built up in a very definite way. The unstriped tissue is thus much more evidently cellular than the striped tissue. But not only the derivation of the striped cells, but also the striped structure of the spindle-shaped cells of certain lower animals, *e. g.*, the disco-medusa, and the presence of the nuclei on the side walls of the fibres, go to show the cellular nature of the striped muscle fibre. The striped tissue is much more rapid and precise in its work, and this is plainly correlated with its much higher specialization of the contractile substance. If it is difficult to understand the ultimate nature of the muscular contraction, so it is in the simplest mass of protoplasm which moves at all, and if we could understand fully the motion of a flagellum of any monad we should have the factors needed to solve the problem of the simple muscular contraction.

Given the striped muscular tissue as a cellular aggregate, and the actions of the tissue as to its use in various parts of the body are not difficult to understand. The biceps flexes the elbow joint, because its fibres are placed lengthwise, and all contracting together, pull on the tendon, and the joint follows and is bent. The sartorius lifts the knee because of the relations of the muscles and bones and the shortening of the fibres. Even the voice of the frog is a special case of muscular

---

\*See Hatscheck Lehrbuch der Zoologie, p. 125.

contractions as well as the leap, or the motions necessary to catch a fly with that movement of the tongue almost too rapid to be seen by the human eye on the alert to see all the act.

While the muscle cells have thus specialized the functions of motion and can perform them with great variety and great efficiency, the other protoplasmic powers of irritability, metabolism, and reproduction are not lost, but only overshadowed. It would be a narrow conception of muscle if we did not include these powers, though they might from their lesser prominence escape notice. The muscle cells in their subordination to the needs of the organism of which they form a part have lost their independence even more than the ciliated cells. They retain their spontaneity, they go on with their action after the body is dead. They are not set at work and stopped from work by orders from higher powers. The muscle cells, on the other hand, have lost this spontaneity and do not work except under orders from the nervous system. But they have the power of irritability, so that when they are excited by the nerves they at once contract. They are all kept really in a state of tonic (constant) slight contraction by constant impulses from the nerves, and can be thence either contracted more or relaxed. It is their very perfect irritability which makes the cells thus controllable. We can easily appreciate the case of tissues composed of cells, some slightly, others strongly irritable, by comparing such a tissue with a company of soldiers. If all were not stirred to instant and simultaneous action by one word of command the company would be totally worthless, and the value of the company depends on the degree to which all respond as one man. It is the old maxim of strength in unity. The irritability of the cell underlies the possibility of so stimulating the hundreds of cells in a muscle like the biceps as to make it perform with great precision. Not only irritability but metabolism is also active in each cell and under its control. Oxygen and food are constantly going into a muscle; carbonic acid and nitrogenous waste products as constantly coming out. More go in and out when it is at work than at other times. If food does not go in, the muscular cells gradually waste away. Sometimes the protoplasm of a muscle cell is replaced with fat and the cell ceases to be capable of contraction. These and many other facts go to show that chemical changes take place in the muscle, and these not at random, but under very exact control. The oxygen combined with portions of the muscle substance produces simpler compounds, and force is freed and used in the contraction or heat is produced, or both. The muscle cell does not, like *amœba*, engulf its food solid, but, after the manner of yeast or the moulds or *gregarina*, it receives the already digested food by dialysis through the wall; but it must have food and oxygen. A mistake in regard to the chemical substance it forms is fatal to the cell, as in fatty degeneration, which is such a case. If these views are correct, and they are in the main the present views of biologists the world around, we are not wrong if we assert that the motions of the frog are all due to the specialization in different directions of the fundamental protoplasmic power of motion, notwithstanding the very diverse kinds of motion and the many quite different structures by which these motions are produced.

[*To be continued.*]

### Rotifer Notes.

BY D. S. KELLCOTT,  
COLUMBUS, OHIO.

**An Interesting Habitat.**—As August was drawing to a close I had the great pleasure of a visit to a sphagnous swamp, where the northern pitcher-plant grew in abundance. Owing to heat and drought the soil of the surrounding country was parched, the water of ponds and streams well nigh dissipated, but every pitcher of this interesting plant was a veritable, minute aquarium, supporting both a variety and a wealth of animal life. It is true the remains of many victims, such as beetles and other large insects, were contained in the older pits, attesting their destructiveness, whilst the living were disporting and multiplying in these shady retreats among the yielding sphagnum. The forms noticed were larvæ of diptera, small worms, infusoria, rhizopoda, and rotifera. Of the last only one species was more than rare; this was *Rotifer vulgaris*, which was exceedingly numerous.

**Rotifer elongatus.**—This remarkable rotiferon was discovered by Mr. E. F. Weber, near Geneva, Switzerland, and described in 1888. In July, 1890, I found it in abundance at Corunna, Michigan. It occurred among the decaying matter of shallow bogs, found only by skimming from the bottom.

I think there can be no mistake in regard to the identification, as the form discovered by me could not possibly be any one of the several described species of this difficult genus; moreover, it agrees very well with the description and figures given in Professor Hudson's "Supplement," page 9, and plate xxxii. The Michigan examples agree with those from Switzerland in size, general outline, corona, proboscis, and habits. I note the following observed characters: it will be seen on comparison that slight differences appear to exist: The body is brown and bears a slight amount of debris; it is not only constricted as described, but fluted; the spines are long, slightly curved towards the toes and taper to a point; there is a slight constriction before the tip in consequence of which the spine is easily flexed as the animal moves about; the toes are nearly the same length as the spines, curved, and gradually tapering to the obtuse extremity; the middle one is shortest. When contracted, the flutings disappear. The extremities when protruded from the telescopic body are wonderfully transparent, affording the clearest view possible of the internal organs.

During July, 1888, I hunted daily for rotifera throughout this same locality and often in the same pond in which it was common in 1890. I did not find it. It was doubtless there, but it had not been made known to science and there was a veil before my eyes. It is often so.

---

### Defects in Certain European Grapho Prisms.

BY L. E. KNOTT,  
JAMAICA PLAINS, MASS.

At the request of the editor, the following notes are presented relative to the drawing apparatus figured in the December number of this periodical. Improvements are, however, constantly being made with a view to overcoming them.

In both the "Zeiss" and Nacet prisms, which, by the way, are both credited to Nacet by Professor Zeiss himself, there is an awkwardness of manipulation due to the necessity of placing the paper close to the microscope stand, and especially if the stand in use be one of the larger of the Continental stands or one of the English models. The Zeiss prism is of such construction that it may be adjusted to throw the image at an angle which, from its position, produced a distortion. The paper must be propped up to prevent this. This defect was overcome by Oberhäuser, but his apparatus is inclined to strain the eye when constantly used. The same is true of Abbe's camera lucida, but it is constantly being improved. The first model of Abbe's had an arm to support the mirror shorter than those now recommended, and with the larger stands consequently failed in their purpose. Those of his latest pattern are so constructed that the mirror may be moved back and forth on its supporting arm, which adapts them to the largest stands, but adding a new, though less pronounced distortion. This is due to the prism being the axis of the refracted image.

The unequal reflections of light from microscope mirror and drawing paper are partially equalized in Abbe's cameras by placing pieces of glass of various density between the camera prism and mirror. In those of Leitz's manufacture he has neatly arranged the glasses in frames hinged in place to the camera, so that they may not be lost.

Another improvement in Abbe's camera is the new method of turning back the camera proper from the centering collar when focussing the object or changing the ocular without the necessity of unscrewing the whole apparatus. Leitz has devised a substitute for this by simply swinging the prism with its mounting to one side.

Zeiss has promised a new sliding method of detaching the Abbe camera at an early date, which will be awaited with interest by those interested in the many valuable microscopic improvements made in his factory.

---

## RECREATIVE MICROSCOPY.

---

**Silver Crystals.**—Ebbage, in the *English Mechanic*, says, with an emphatic caution, not to spill the solution because it stains black; that a pretty object is the arborescent growth of silver crystals. Dissolve a small crystal of silver nitrate or a piece of lunar caustic in a few drops of rain-water. Place a drop of this solution in the centre of a slip of glass, and arrange it under a low power, concentrating the light from above by means of a condensing lens. Now take a piece of copper wire  $1\frac{1}{2}$  inches long and bend it like the letter L, and bend the longer limb in form of a hook, which will rest anchor-fashion when laid down. Place this at the side of the drop of solution, allowing the hook to dip into it at the edge. Chemical action results, copper going into solution and silver crystalizing out while the process is watched through the microscope.

**For Mounts.**—Get your druggist to save you some of the powders left after exhaustion by percolation. Many of them make fine microscopic objects.

## EDITORIAL.

*All communications for this Journal, whether relating to business or to editorial matters, and all books, pamphlets, exchanges, etc., should be addressed to American Monthly Microscopical Journal, Washington, D. C.*

**The Needs of American Microscopy.**—The first and great need is a profound awakening among students, teachers, workers, and all inquiring minds to the value and possibilities of this branch of human knowledge. It is amazing that out of one hundred thousand physicians in this country, not one of whom can be a competent practitioner without being able to use the microscope continually, not two thousand take a microscopical journal, and not a hundred are members of the American Microscopical Society. Out of thousands of teachers of physics or biology in the schools and colleges, not over ten per cent. show an interest in microscopy. But one National Society exists here devoted to the subject, and its average annual attendance is less than 75 members, while the number of papers read at the Washington meeting of 1891 was less than a score.

The second need, and it is one which would help realize the first, as it is also one to naturally follow the realization of the first, is a truly national periodical devoted to the subject. Two competitors for this place may be said to exist: this *Journal* and *The Microscope*. On many accounts it would have been far better had the field been left to either one, as the combined patronage would make nearly twice as good a monthly as either one is, but both are here and they are here to stay, and, at least while under present management, to live happily and peaceably side by side, rejoicing each in its own and also each in the other's prosperity, and furthermore we shall not cover the same ground nor feel content that our subscribers take but one of the two periodicals. We urge you all to take both, and we make you a slight financial inducement to do so.

The third need, and that is a pressing one and which this *Journal* will undertake to supply, is for American microscopists to be able to see a monthly resumé of the world's news, progress, and discoveries in microscopy. We accordingly extend this month the plan of brief notes heretofore entered upon, and hereafter hope to much more fully cover the field. There are about 40 publications of a periodical character which we shall attempt to epitomize for you, giving in brief the gist of their contents, when not too abstruse and when capable of being abstracted, but distributing the items under our various headings as heretofore. If the American microscopists generally could afford to take the *Journal of the Royal Microscopical Society* at an expense of \$7.50 per annum and could spend the time to go through its 900 pages, our course would not be absolutely necessary—only a national pride. But this is out of the question. So far as inquiry reveals to us, not over one per cent. of our readers take that journal, and not over 100 copies come to this country all told. Additionally, it is a quarterly with immensely varied matter, and time is lost in transit.

With the growth of patronage and enthusiasm, we shall be able to increase our pages in number, and to reach out more and more towards the full realization of that need. But the beginning must be made now.



If the plan commends itself to our friends, we hope to hear so. And we shall, of course, have to curtail the publication of lengthy papers in order to make more room for our resumé's.

The publication of matter for amateurs and beginners has always been demanded by certain classes of subscribers. There are now a sufficient number of books of this character, and our inexperienced friends ought to make use of such books so as to enable us to use our space for matter alluded to in this article.

We shall, however, try to bring our matter within the grasp of all, whether expert with the microscope or not.

A copy of "Carpenter on the Microscope" is indispensable for every person interested in the subject, young or old. By the aid of it, amateurs will be able to interpret much that appears in the current literature. The new edition by Dr. Dallinger is just out and published at \$6.50 per volume, but as an inducement to our friends to purchase for the purpose indicated, we will supply it as a premium to those remitting for their 1892 subscriptions (all previous subscriptions having been paid) for \$4.75 per volume. To all others our price is \$5.00 per volume.

To any amateur becoming a new subscriber we will send upon application a free copy of White's "Microscopy for Amateurs."

With thanks to all our friends for their past favors and indulgences, and a promise of hearty co-operation in all that will advance the art we love and the sciences to which it ministers, we enter upon the new year.

## MICROSCOPICAL APPARATUS.

**A New Polarizer.**—Owing to the growing dearth of Iceland spar something must be done to maintain our powers of polarization. Prof. S. P. Thompson proposes producing polarized light without the Nicol prisms. As described to the British Association, he reflects the light from a black glass mirror, whose surface is covered with a plate of clear glass. Light from a lantern is reflected onto the mirror with a total-reflecting prism. A second reflecting prism most carefully annealed turns the polarized light back into its original axis.

**Glass for Immersion Oil.**—Behrens uses a bottle made by Zeiss, which is cylindrical, 60 mm. high and 30 mm. wide. The neck of the bottle is very wide (15 mm.) and is ground. Upon the neck fits a cap carrying a glass rod, which reaches to the bottom of the bottle. At the upper end of this solid rod is a glass hemisphere, which is cemented by shellac into a hole in the cap. It is  $1\frac{1}{2}$  mm. in dia. and 60 mm. long. At the lower end of the rod is a small glass ball (2 mm. dia.), which prevents the oil dropping off.—*Z. f. W. Mikr.*

**Making Lenses.**—The bit of glass to be formed into a lens is fastened by means of pitch to a small block of hard rubber so that it may be more readily handled. It is ground by being pressed against a rapidly-revolving metal tool, whose curvature is equal and opposite to that desired in the lens. This is known as the "rough tool" and is made of cast iron. It is mounted on a vertical spindle, and is kept moistened with emery and water. Several grades of emery are used in succession, changing from coarse to fine as the grinding proceeds. As a re-

sult of this process the glass has a rough surface and is no longer transparent. It is now transferred to the "fine tool." This is made of brass and has its surface as true as possible. It is compared from time to time with a standard curve, in order to insure accuracy. In this second grinding the abrading material is rouge (carefully calcined sulphate of iron). Finally, the lens is polished by being pressed against a piece of cloth powdered with rouge and fastened to the rotating tool. The glass is now loosened from its block, turned over, and the reverse side of the lens ground. When this has been accomplished, the lens must be cut down to the proper shape for mounting in the spectacle-frame. It is placed on a leather cushion and held firmly in position by a rubber-tipped arm, while a diamond glass-cutter passing around an oval guide traces a similar oval on the glass below. The superfluous glass outside of the oval is removed by steel pincers, the rough edges are ground smooth on Scotch wheels and the lens is ready for mounting. The glasses for small telescopes, microscopes, burning-glasses, and the like are ground in the same fashion.—Prof. C. H. HENDERSON, in *The Popular Science Monthly*.

**Collecting Sediment for Examination.**—Dr. Ruttan, of Montreal, allows the water to stand in a large vessel for a time and then syphons off the clear water, leaving a small amount of water with the sediment. This residual, well shaken, is transferred to a tube (60 x 100 cm.) supported by the Bunsen stand. This tube has an aperture in the constricted base fitted exteriorly with a small glass cap, into which the converging sides of the tube conduct the sediment. A rubber stopper with a long handle may be let down through the water and close the tube just above the cap. The cap when removed contains the sediment and scarcely any water. The tube is graduated for 1, 2, or 3 litres of water, and the sediment of 3 litres deposited in about 50 cc. space quite ready for microscopic examination or for quantitative measurement.

### MICROSCOPICAL MANIPULATION.

**A New Mounting Fluid.**—Mr. Haly, curator of the Colombo Museum, Island of Ceylon, used carbolic acid, cocoanut oil, and turpentine, which readily mix together, to form a fluid in which objects may be allowed to soak without any previous preparation and in which they become very transparent. He kept the leg of a fly on a slide in a drop of this fluid for ten months without alteration. No cell was made, no cement employed, and an ordinary cover-glass was simply laid over the object. We have written Mr. Haly, asking for the proportions which he used.

A more extensive use of cocoanut oil and carbolic acid was made for a preservative fluid, and it was found to preserve the colors of various animals, including those most changeable colors of fishes and of frogs and of snakes, in the most beautiful manner. The mixture used for that purpose consisted of cocoanut oil raised to the specific gravity of 10° or of 20° below proof-spirit by the addition of carbolic acid.

Fuller data may be found in the last annual report of the Colombo Museum.

**Crustacean Eyes** are stained by G. H. Parker with alum cochi-

neal and mounted in benzol-balsam. They are depigmented by an aqueous solution of potassic hydrate ( $\frac{1}{4}\%$ ).—*Bull. Mus. Comp. Zool.*

**Dried Algæ** may be restored to fresh condition, even if quite black, by the use of eau de javelle<sup>3</sup> for maceration.—*Ber. Deutsch. Bot. Gesell.*

**Resolution of Amphipleura Pellucida.**—Mr. J. W. Gifford, F. R. M. S., has examined a frustule with sodium light illumination under which dots were unmistakably shown, and they became more marked when the frustule was moved to the side of the field. He attempted photographing them, using plates treated with an erythrosine bath, but these plates were sensitive only so far down as the yellow part of the spectrum. Then a solution of iron perchloride was used as a screen to cut off all the blue end of the spectrum. In this manner the part used for photographing was reduced to a narrow band about midway between the D and E lines of the solar spectrum. The markings seemed to equal those claimed for *Surirella gemma*. He expressed the opinion that in both cases they are simply multiplied rings of the mid-rib and sides produced by the higher order of diffraction spectra according to the Abbe theory. The mounts were of a sulphide of arsenic derived from mixing sulphur and realgar, and difficult to make.

With sodium light and a color-correct plate, achromatic object-glasses work almost as well as apochromatic. The beads were not seen with any glass of less than 1.4 aperture and the best results came with Powell and Lealand's apochromatic 1-10 of 1.5 and achromatic 1-20 of 1.5 and 1-12 of 1.43.

Zeiss' projection ocular was used.

## BIOLOGICAL NOTES.

**Sex Determined by Temperature.**—Maupas finds that at the commencement of oogenesis the egg of a certain rotifer is neutral. If temperature is lowered, females result; if increased, males result.—*Comptes Rendus.*

**Life After Desiccation.**—Cobelli has dried some rotifers for over five years, but after soaking a few days (3 to 7) the bodies distended and under the microscope the internal organs are found to be in a good state of preservation.—*K. K. Zool. Bot. Gesell.*, pp. 585-6.

**Malaria parasites** have been found in birds. There are two kinds, both possessed of a nucleus, which prevents calling them degenerations of red corpuscles.—*Centralbl. f. Bak. u. Par.*, pp. 403, 404.

**The Radish**, which normally contains but little starch, may be induced to secrete a large quantity if the seedlings are watered with salt water. Lesage uses 4 gr. of sodium chloride to 1,000 gr. water.

**Hepatica triloba**, which ordinarily has a 3-lobed leaf, has been observed by Hildebrand to put up in two successive years 2-lobed leaves. Other sudden changes of form are noted by him in *Ber. Deutsch. Bot. Gesell.*, pp. 214-8.

**Jumping Seeds.**—*Wistaria sinensis* has been observed by Huth to expel its seeds a distance of 10 meters (by night). He notes 48 genera in which the fruit is violently expelled. These are of three classes:

I. (1) Dry fruits in which the carpels roll up when ripe so as to expel the seeds. (Many leguminosæ, etc.) (2) Climbing plants bear-

ing hooks or bristles, which catch upon animals and when released spring back so suddenly as to expel seeds.

II. Hygroscopic fruits (sensitive to moisture), such as the equisetum.

III. Succulent fruits in which expulsion is caused by a sudden access of water, such as *oxalis*, in which the mechanism lies not in the pericarp, but is a fibrous layer enveloping the seed.—*Sam. Naturw. Vorträge*.

**Strength of Vegetable Growth.**—Some years ago the elm and other trees on 4½ street in Washington were surrounded by cast-iron frames securely riveted together at the four square corners. The growth of the trees has burst the castings apart in many places. In some of the places the iron was a half inch or more thick where it broke. These protectors are still standing and the breaks open to inspection.

**Fermentation of Bread.**—Not only does the yeast set free the gases which cause the dough to rise, but it prevents the bacteria which are parasitic in the starch from developing, in which case the dough would sour and the gluten dissolve. Boutroux finds three distinct microbes in yeast, but thinks they play no part in fermentation. Chicanard says that when the dough is placed in the oven it contains immense numbers of bacilla, but no yeast cells. He consequently regards fermentation to be the action of *Bacillus glutinis* on the gluten.—*Comptes Rendus*.

**Growth of Sea Weeds.**—Oltmanns has tried increased and decreased salinity upon the growth of algæ and reports that 1 to 18-10% of sudden variation is prejudicial to their growth, while a gradual change produces but slight effect. The plant cells cannot adapt themselves suddenly to change of turgor. Different species show different degrees of inability.—*Preuss. Akad. Wiss.*

**Sugar Cane Diseases.**—Krüger describes "dust brand," "red spots," "rust," and "sclerote" as due to fungus parasites; which are very destructive in Java.—*Ber. Vers. Zuck. in West Java*.

**An Elm Parasite.**—Dr. Zabriskie has described and figured a fungus as *Pestalozzia insidens*, which he found in New York. (See *Journal of the New York Microscopical Society*, 1891, p. 101.)

**Life in Great Salt Lake.**—Dr. J. E. Talmage, of Salt Lake City, Utah, recently elected F. R. M. S., exhibited to the society some specimens of *Artemia fertilis* from Great Salt Lake, and explained the occurrence of life in the lake. We should like to hear from him on the subject.

**A Pink Micro-Organism** of great beauty but of undetermined name was found in September by Prof. W. A. Herdman, of University College, Liverpool, while dredging in Loch Fyne. His attention was attracted to a number of pink patches on the sand, which under a low power proved to consist of clear quartz sand grains incrustated with bright pink jelly masses averaging 0.1 mm. in length. Each jelly mass was crowded with short rods of 0.0015 mm. in length and half that breadth. He suggests, in *Nature*, that it may possibly be a form of *Beggiatoa rosea-persicina* and offers specimens to biologists who are familiar with the zoöglæa condition of micro-organisms. The occurrence of such a form on clean sand in pure sea-water is unusual. The patches were a foot in diameter just below water at lowest tide, and presented much the appearance of pink blotting-paper.

## MEDICAL MICROSCOPY.

**A Troublesome Cotton Seed.**—Last June a child in South Carolina was found to be suffering with what seemed to be ozena, and the odor was simply unbearable. Dr. Geo. Howe extracted a foreign body and turned it over to Prof. E. E. Jackson, of Columbia, S. C. The object was oval in shape and measured 6-16 x 14-16 inch. A velvety substance covered it, while scraping revealed cotton fibres and fragments of hard crust showed cellular structure. Placing them under the microscope, polarized light revealed the colors peculiar to cotton seed, as did the fibres. No oil globules were discovered. The seed had been *in naves* for two years.

**Purulent Arthritis without Micro-organisms.**—A case is reported of a man 69 years old suffering from this disease, but whose pus contained no microbes. Not only experiments but a searching microscopical examination showed this. A simple aspiration cured the case. In another no microbes could be found, though the patient died after having his joint tapped. The man of 57 was a diabetic.

**The Bacillus of Typhoid** has been subjected, by Janowski, to the action of light, who reports its development prevented by the chemically active rays of the solar spectrum. He exposed test-tube cultivations to the action of diffuse light, and deprived others of light. The action of direct sunlight was to stop development in from 5 to 10 hours. He also tried interposing screens of bicromate of potash, alum, fuchsin, gentian-violet, etc., in solution.

**Influenza** being caused by the multiplication of bacilli, which experiments show to grow best in certain nutrient media, such as beef tea at 98° F., Dr. Crerar, of Edinburgh, thinks that the treatment demands a curtailment of nutrient media and an alkaline condition of the system. Hence he gives bicarbonate of potash as one of several ways to produce a greatly increased alkalinity. Dose: 30 grains in a teacupful of milk every two or three hours. A few drops of the tincture of capsicum may or may not be added. If heart action is weakened by the drug, digitalis will quickly restore it. If diarrhœa results give Dover's powder.

He thus would exhaust the disease without it having any course, provided the vital powers are sufficient to resist the poison taken to destroy the microbe. This treatment involves the immediate multiplication of a baneful and death-producing plant—the pathogenic fungus, it being known that during the growth of micro-organisms a peculiar substance is formed which is eventually fatal to its own microbe.

**Germ of Diphtheria.**—*F. Blanchard, M. D.*, gives the following ways in which they may be conveyed from the sick to the healthy:

By immediate contact, as in kissing.

By particles of throat secretion forcibly ejected during examinations and thrown directly into the mouth or nostrils of the examiner.

By inhalation of a patient's breath.

By inhalation of dried sputum suspended in the air as dust.

By the clinical thermometer, if temperature is taken in the mouth. (Take temperature in the axilla.)

By using undisinfected utensils, as spoons, tongue-depressors, drinking glasses.

By pipes, pens, pencils, etc., that have been in the mouth of the sick.

By the hair, whiskers, or clothing of nurse or doctor.

By wearing clothing that has been worn by the sick.

By reading a book or letter that has been in the hands of the sick.

By eating butter or drinking milk from an infected house.

By drinking water contaminated by sputum which has been thrown into the water or upon the ground whence it has filtered into wells, etc.

By drinking water contaminated by seepage from cemeteries where those dead from diphtheria have been buried.

### MICROSCOPICAL NEWS.

The Microscopical Exhibition at Antwerp, which was announced several months ago, was held in September under the management of Dr. Van Heurck, the microscopical inventor and director of the Botanical Garden at Antwerp. Americans do not seem to have taken part therein, even the editor of this *Journal* who was in Paris at the time not being able to attend. We learn, however, that the most prominent exhibitors were as follows:

Nachet, Paris.—His microscopes and other instruments.

Tempère, Paris.—Diatoms in great beauty and profusion.

Adnet, Paris.—Bacteriological apparatus.

Möller, Wedel.—4,026 distinct forms of diatoms.

Lumière, Lyon.—Figures of microbes.

Watson, London.—Van Heurck's magnificent microscope, the Edinburgh Students' Microscope, and other apparatus shown in their catalogue.

Powell & Lealand, London.—Microscope and objectives.

Hartnack, Potsdam.—Microscopes, object glasses, photo-micrographic apparatus.

Zeiss, Jena.—Microscopes of all descriptions. A collection illustrating the production of lenses from crude glass through every stage of grinding.

To atone for American indifference at this exhibit we ought to be arranging for a great display at Chicago in 1893.

**Sharp Practice.**—A school teacher returning from Europe this fall brought a microscope for his use in biological study, trusting to sec. 686 of the tariff law, which puts in the free list "professional books, implements, instruments, and tools of trade, occupation, or employment in the actual possession at the time of arriving in the United States." On landing in Boston the customs officers demanded duty and the collector sustained them. Whereupon the instrument was given to the institution where the teacher was employed and so got in free of duty. Perhaps this teacher will feel like taking the trouble to vote next November.

**Diatom Notes.**—J. D. Cox proposes to reduce very greatly the number of species. Deby objects and thinks that Cox's "transitory" forms should stand as species.

Tempère and Peragallo have ready 31 parts of a series of preparations of diatoms of France. Each part contains 12 species.

M. J. Brun has described a number of new species and established two new genera. (See *Mém. Soc. Phys. Genève*, xxxi, part ii.)

Shrubsole announces *Streptotheca tamesis* as new. It is found every fall and winter at the estuary of the Thames.—*Jour. Quak. Club*, pp. 259-62, with plate.

Peragello has published a monograph of the *pleurosigma*, *rhoicosigma*, *donkinia*, and *toxonidea*.—Paris, 1891, 10 plates.

## MICROSCOPICAL SOCIETIES.

SAN FRANCISCO.—WILLIAM E. LOY, *Sec'y*.

*November 4, 1891*.—R. H. Freund exhibited Zeiss' apparatus for counting blood corpuscles. A discussion followed, and it was asked whether or not by this test data might be established whereby one could determine if blood under examination belonged to man or to some of the lower animals. Authorities are agreed that the size and shapes of the red corpuscles are so nearly alike in man and some of the lower animals that some other test must be found. At present Zeiss' apparatus is used only for determining the relative proportion of red and white corpuscles, on the variability of which certain diseases can be diagnosed. Mr. Freund also exhibited some pathological preparations, *actinomyces bovis*, *diphtheria bacillus*, and *typhus bacillus*.

George O. Mitchell reported the results of attempts to make photomicrographs with the Society's camera, and exhibited some of the work, which was favorably commented on.

The Secretary reported the receipt of two samples of diatomaceous earth from Henry G. Hanks—one from Maine, showing fresh-water forms; the other from a well in Adams county, Washington, also fresh-water forms.

Henry C. Hyde spoke of the death of Judge O. C. Pratt, a life member of the Society.

*November 18, 1891*.—George A. Merrill and P. S. Barber were elected members. The meeting was then formally adjourned, and Henry C. Hyde, on behalf of the committee, took charge of the exhibit.

A. H. Breckenfeld exhibited with dark-field illumination a living *Hydra vulgaris*, budding, head of *Vespa vulgaris*, arranged diatoms, a section of *Equisetum* (fertile stem), *Lepidodora hyalina*, and seeds of *Orthocarpus purpurescens*. Dr. E. S. Clark exhibited some beautiful opaque objects, including a section of chalcedony, showing cinnabar and metallic mercury; silver crystals (artificial), gold crystals (native), a Cliff House sponge, gold crystals (artificial), and a gorgeous insect, *Corythuca hyalina*. M. E. Jaffa showed a series of slides, exhibiting the germs of lactic, acetic, and vinous fermentation.

Dr. Herzstein showed several preparations of pathogenic bacteria, including *Gonococcus* in pus, a pure culture of *Streptococcus* and *Staphylococcus Pyogenes aureus*, in pus. These were all shown with an apochromatic immersion lens, an apochromatic condenser, and compensating eye-pieces, giving a beautiful image. Charles C. Riedy showed the circulation in the tail of the stickleback and several diatoms mounted in iodide of mercury, the latter with an amplification of 1,000 diameters.

George O. Mitchell had an attractive exhibit, consisting of various chemical crystals shown with polarized light. The list included *Aspa-*

*ragin. Sodium bitartrate Salacin, Sodium nitro-prusside, Hippuric acid and Palmitic acid, the latter showing the formation of crystals under the lens. William E. Loy showed a series of slides illustrating the fructification of ferns, including the local species, *Gymnogramme triangularis, Polypodium aureus, Aspidium rigidum, Adiantum cuneatum, and Picris aquilina.**

These public exhibitions will be given each alternate month hereafter, the Society feeling satisfied that they are not only educating in their results, but add to the membership as well.

#### WASHINGTON, D. C.

*Dec. 1, 1891.*—Dr. H. H. Hauxhurst was elected a member. A sample of diatomaceous earth was presented by G. R. Lumsden, of Greenville, Conn. A new microscope stand and accessories was ordered. Dr. Reyburn read a paper on the germicidal treatment of diphtheria. Dr. Moore read a paper on the biology and morphology of the Klebs-Loeffler bacillus. A slide of bacillus culture was exhibited.

*Dec. 15, 1891.*—Dr. Balloch presided. Some fine photo-micrographs of pathological specimens made by Dr. W. C. Borden, of Fort Ringold, Tex., were exhibited by Mr. C. W. Smiley.

Dr. Acker read a paper on *Tinea tonsurans*, which was illustrated by slides showing the fungus.

*Jan. 5, 1892.*—Mr. Oscar C. Fox, of the U. S. Patent Office, was elected a member. Dr. E. A. Balloch read a paper on the pathology of elephantiasis and exhibited a slide containing a section of tissue taken from an African residing in Washington. The negro race is said to be especially predisposed to this disease.

A copy of the new edition of Carpenter on the microscope was exhibited by Dr. Reyburn.

#### AUSTIN MICROSCOPICAL SOCIETY, AUSTIN, TEXAS.

*October 31, 1891.*—Organized. Elected Dr. J. W. McLaughlin, President; Dr. A. N. Denton, Vice-President; Dr. T. J. Bennett, Secretary. The Society will study normal and pathological histology, bacteriology, and have social as well as literary meetings.

#### ROYAL MICROSCOPICAL SOCIETY, LONDON.

*Nov. 18.*—C. L. Curties showed a small heliostat, made on Cumber's lines, which is simple and effective in any latitude between 15° and 75°.

Mr. Gifford spoke on resolution of *Amphipectera*.

Mr. Curties also exhibited a new form of microscope made on the Nelson model, and Mr. Nelson described some improvements in his apparatus for producing monochromatic light for use with the microscope.

Mr. A. W. Bennet gave a paper on some fresh-water algæ of Surrey, including several new species.

#### MICROSCOPICAL CLUB, ST. LOUIS, MO.

*Jan. 5, 1892.*—*Annual Meeting.*—The reports of officers were very encouraging, and the past year a prosperous one. The journals for 1891 were ordered bound, and the subscriptions all continued for 1892. A new cabinet was ordered, the old one having been filled. Mr. Harry



Stark was authorized to exchange duplicate mounts. The Society will meet on the first Tuesday of each month in 1892, at the College of Pharmacy. The officers elected were as follows:

President, Dr. J. C. Falk; Vice-President, T. A. Buckland; Treasurer, Dr. H. M. Whelpley; Secretary, S. E. Barber; Curator, William Elhardt.

#### MONTREAL MICROSCOPICAL SOCIETY.

*Nov. 9, 1891.*—At the annual meeting, J. Stevenson Brown, Esq., delivered the presidential address on "The Duty of Science," and was re-elected President. Leslie J. Skelton was elected Hon. Secretary; J. S. Shearer, Hon. Treasurer.

The membership has trebled during the year, although persons "must be possessed of an achromatic microscope" to qualify them for election. The Society is free from debt, and all dues from members were reported paid. The meetings are held in the library of the Natural History Society on the second Monday of each month.

Among the papers presented at previous meetings of the year were: "Illumination as Applied to the Microscope," by the President; "Facts Connected with Keeping an Aquarium," by Dean Carmichael; "Hints on the Microtome," by W. G. Johnson, M. D.; "Histology of the Eye of the Owl and Lobster," by J. W. Stirling, M. D.; "The Microscope and Bacteriology," by J. A. Beaudry, M. D.; "The Polariscopes as Applied to the Separation of Starches," by G. P. Girdwood, M. D.; "The Bacteria in Montreal Drinking Water," by W. G. Johnson, M. D.; "The Bacillus of Diphtheria," by J. B. McConnell, M. D.

*Dec. 14, 1891.*—Sir William Dawson, LL. D., President of McGill College, read a paper on "The Use of the Microscope in the Study of Fossils."

The lecture was most interesting owing to the fact that Sir Wm. not only gave in clear, concise terms the accumulated results of years of continuous research, but also demonstrated at the same time some of the difficulties that the early investigators had to contend with, owing to the poor instruments at their command. The lecturer exhibited his first microscope, of date 1834, which, on comparison, proved much inferior to those now in use. Nothing could mark more clearly the optical advance, made to meet the increasing demands of science, than a comparison between this instrument and that of to-day.

Attention was directed to a number of the foraminifera of the lower St. Lawrence and a comparison drawn between these and those from other sections. A sample of clay taken from the excavations made for the new Experimental Physics building, in McGill College grounds, was shown to be largely composed of foraminiferous matter. The ordinary limestone of which the city of Montreal is so largely built was demonstrated as owing its origin to these minute organisms, which had lived, built for posterity, and perished ages ago.

Sponges and corals were also treated of at some length and their formation and structure explained.

At one time the coal formations of Cape Breton, N. S., had been studied by Sir William, and some very interesting results were submitted to the meeting and compared with observations elsewhere.

The lecture was illustrated throughout with slides, fossils, rock sec-

tions, and illustrations prepared by Sir William for the different works he had published.

During the meeting a letter was read from His Excellency, the Governor-General, expressing his regret at being unable to attend.

### NOTICES OF BOOKS.

*Essentials of Bacteriology.* By M. V. Ball, M. D. Philadelphia. W. B. Saunders. Pub. 1891, pp. 159, figs. 77.

The author, who is assistant in microscopy at Niagara University, Buffalo, has undertaken a concise and systematic handbook for students of micro-organisms, and in 150 pages has brought within the grasp of any intelligent student the substance of all that is thus far known about bacteria and their manipulation. Dr. Ball studied in Berlin under Koch and Fränkel. He has compiled largely from the following books:

Macé: *Traité pratique de Bacteriologie.*

Salmonson: *Bacteriological Technique.*

Fränkel: *Grundriss der Bakterienkunde.*

Eisenberg: *Bakteriologische Diagnostik.*

Gunther: *Einführung in das Studium der Bacteriologie.*

Crookschank: *Manual of Bacteriology.*

Woodhead & Hare: *Pathological Mycology.*

The books cited are the most important works on the subject. To this list Dr. Ball's book should be added, as constituting an epitome of them all. His illustrations and head-lines go far towards giving clearness to the subject. The publisher, who offers this volume as No. 20 of a series of Question Compend, has presented the book in nice form, but he has added to it a long catalogue of books. When one turns to the end of the volume to find an index it is annoying to find instead a lot of advertisements. But the book is so good in this case that we merely say, "Don't do so some more."

*School and College.* Edited by Ray Greene Huling. Monthly, 64 pp. Ginn & Co., Boston. \$1.50 per annum.

As the name indicates, it is expected to cater to educational interests of the higher sort. The improvement and co-ordination of secondary and higher education is announced as its leading theme. One of the early problems for solution is to be the question of time and expense wasted over entrance examinations. Compulsory Greek is another urgent topic, and if Brother Huling succeeds in driving Greek to the rear we shall, for that alone, consider that he has not lived in vain, editorially speaking.

*The Sanitarian.* A monthly publication edited by Dr. A. N. Bell. 96 pp. \$4.00 per year. Clubbed with this journal, \$3.50.

*The Sanitarian* is devoted to the promotion of sanitation, mentally and physically. It includes the investigation, presentation, and discussion of all subjects in this large domain, as related to personal and household hygiene, domicile, soil and climate, food and drink, mental and physical culture, habit and exercise, occupation, vital statistics, sanitary organizations and laws. Everything promotive of or in conflict with health is included, with the purpose of rendering sanitation a popular theme of study and universally practical.



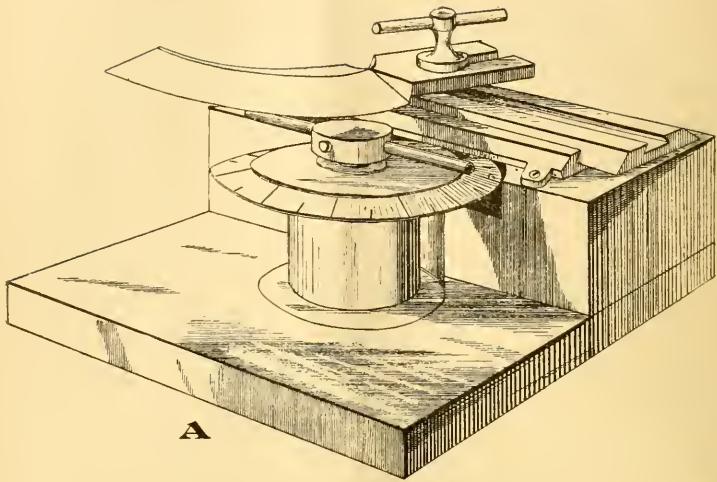

**A**

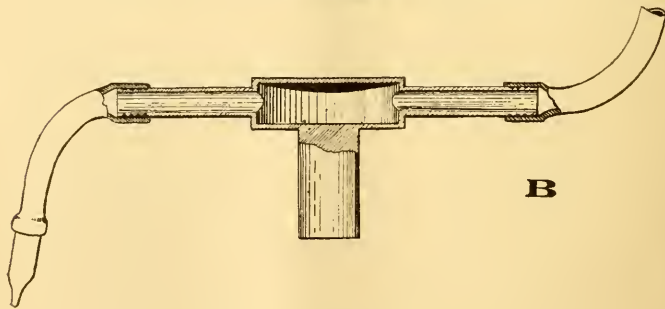

**B**

TAYLOR'S FREEZING MICROTOME.

# THE AMERICAN

## MONTHLY

# MICROSCOPICAL JOURNAL.

VOL. XIII.

FEBRUARY, 1892.

No. 2.

### CONTENTS.

<p>Taylor's Freezing Microtome.—(Illustrated).—TAYLOR - - - - 25</p> <p>Introduction to Elementary Biology.—OSBORN - - - - 26</p> <p>A Proposed New Desmid.—(Illustrated).—HASTINGS - - - - 29</p> <p>Notice of Walter H. Bulloch.—TOLMAN - - - - 29</p> <p>Apparatus for Controlling Living Organisms Under the Microscope.—(Illustrated).—SCHULTZE - - - 30</p> <p>Interesting Items on Diatoms.—COX EDITORIAL.—Too Scientific. Prompt Publication - - - - 32</p> <p>MICROSCOPICAL APPARATUS.—Camera for Micro-photography—(Illustrated). A Nice Sterilizer - 39</p> <p>MICROSCOPICAL MANIPULATION.—Demonstrating the Influenza Bacillus. Determining Magnification. To Detect Air Bubbles. To Clean Objectives. Mounting Opaque Objects. To Mount Sand Dry. Confining Living Forms. Mounting Tubercle Bacilli. Cement - - - - - 40</p> <p>BIOLOGICAL NOTES.—Sweet Potato Blossoms. Duration of Life. Bumble-bee in New Zealand. Preserving Botanical Specimens.</p>	<p>Diatom Multiplication. Watermelon Juice. Biological Specimens. An Insectivorous Plant. 41</p> <p>DIATOMS.—Diatoms from new Localities - - - - - 42</p> <p>BACTERIOLOGY.—Discovery of the Influenza Bacillus. Souring of Milk. Chemically Pure Water. Beer may contain Bacteria. Carbon Favorable to Growth of Microorganisms - - - - - 43</p> <p>MEDICAL MICROSCOPY.—Prevention of Influenza. Actinomycosis again. The Microscope in Diagnosis. Dust Injurious to the Lungs. Trichina - - - - - 45</p> <p>RECREATIVE MICROSCOPY.—Brownian Movement. Diatom Material. The Sugar Insect - - - - - 46</p> <p>MICROSCOPICAL NEWS.—Adulterated Bread. Milk. How Lenses are Made - - - - - 46</p> <p>CORRESPONDENCE.—White's Objects - - - - - 47</p> <p>NEW PUBLICATIONS.—Brockway. Ward. Childs. Senn. Daburn. Bremer. Wanamaker. Kelsey - - - - - 47</p> <p>WANT, SALE, AND EXCHANGE NOTICES - - - - - COVER.</p>
------------------------------------------------------------------------------------------------------------------------------------------------------------------------------------------------------------------------------------------------------------------------------------------------------------------------------------------------------------------------------------------------------------------------------------------------------------------------------------------------------------------------------------------------------------------------------------------------------------------------------------------------------------------------------------------------------------------------------------------------------------------------------------------------------------------------------------------------------------------------------------------------------------------------------------------------------------------------	-------------------------------------------------------------------------------------------------------------------------------------------------------------------------------------------------------------------------------------------------------------------------------------------------------------------------------------------------------------------------------------------------------------------------------------------------------------------------------------------------------------------------------------------------------------------------------------------------------------------------------------------------------------------------------------------------------------------------------------------------------------------------------------------------------------------------------------------------------------------------------------------------------------------

## Taylor's Freezing Microtome.

By DR. THOMAS TAYLOR,

WASHINGTON, D. C.,

[WITH FRONTISPIECE.]

This combination microtome is adapted to three methods of section cutting.

The instrument is of metal screwed to a block of polished mahogany. There is a revolving table with graduated margin, in the center of which is fitted a freezing-box having two projecting tubes, one to admit freezing water, the other an outlet for it. The water is supplied from the reservoir and carried off by means of rubber tubing which is attached to the metal tubes, the terminal end of the outlet tube being furnished with a small glass tube by means of which a too rapid outflow

of water is prevented. The tubes of the freezing-box are so arranged as to prevent their revolving with the revolutions of the table. In B is shown a sectional view of the freezing arrangement.

When ether is used the little brass plug in front of the freezing-box is removed, and the rubber tubing detached.

In preparing to make sections, remove the freezing-box and in its place substitute a cork which projects suitably, holding the object from which sections are to be taken, embedded in wax or paraffine, at the required angle to the blade of the knife. The cork is raised or lowered by means of a finely cut screw-thread.

The curved knife is about five inches in length and one inch in breadth, ground flat on the under side, and held in position by a binding screw, after the fashion of several microtomes previously in use. A straight knife may be used if desired.

### Introduction to Elementary Biology.

BY HENRY L. OSBORN,  
HAMLIN, MINN.

#### PART VII.—A SPECIFIC LIFE HISTORY CONSIDERED BIOLOGICALLY.— THE FROG.

(Continued from p. 13.)

The tissues of motion in the frog having now been shown to be groups of cells or cell derivatives which have specialized the power of movement, it is natural that we should enquire whether the other protoplasmic powers have been specialized and other tissues formed with the special functions of irritability, metabolism, and reproduction. And we shall find that such has been the case. At present we shall look at the function of irritability. If any of the protozoa are suddenly shocked or stimulated by a force without their bodies they quickly withdraw from that force and we call this a case of irritability, saying that the animal is in some degree sensitive to its surroundings. This power to know its surroundings is of the utmost importance to a living being for it must plainly precede the power to adjust itself to the surroundings—to utilize the useful, to shun the hurtful. Most plants lack the power of motion and sensation or if they have them at all they are extremely feeble, while on the other hand most animals show the presence of both powers in a more or less considerable degree. We should then expect a sensory organization of some kind in as high an animal as the frog.

If we decapitate a vigorous, healthy frog and suspend it by the front end of the trunk allowing the legs to hang down, and then dip the tip of the longest toe in a weak solution of acetic acid (1%) the muscles of the hip and knee joints will gently flex those joints and the foot will be slowly lifted from the acid. Such an action is known in physiology as a reflex action. A moment's consideration shows us that we have not done anything directly to the muscles whose shortening lifted the legs, for they are several inches away from the seat of the irritation. And yet the muscular action was caused by the irritation. If we examine the frog's leg we shall find white threads, some of which go to the skin and others to the muscles. These are the nerve trunks or "nerves." They are composed of numerous fine threads, too fine

to be seen with the naked eye, but not very small as cell structures go; these threads are the ultimate nerve fibres. They are very long threads of protoplasm which are irritable; any change on any part of the thread disturbs the molecular arrangement, which disturbance subsides at the first spot, but before doing so disturbs the protoplasm next to it in every direction. The thread is surrounded by a fatty sheath and bound in by a very delicate membrane, but we are to regard these latter as merely accessory, like, for example, the wrapping around a wire for electric conduction which has nothing primarily to do with the conductive work of the wire. I do not want any one to think that I mean to say that the nerve force is a form of electricity, for it is not any more than muscle force or gland force, but my illustration means only that the white sheath is not the active irritable protoplasm but an inert cover for that substance.

Biologists do not pretend to state positively the real nature of any of the molecular processes taking place in protoplasm; they do not even know the precise structure of any one molecule of the various ones which enter into it. But we know, from the study of blood going into and from a nervous organ and in other ways, that they are extremely unstable compounds and that decomposition accompanies the activity of the nerve fibre, and hence we infer that the stimulus to the nerve at any part causes a chemical disturbance and slight metabolic destruction, which causes in turn a similar one in the next and next and next parts which is a propagation of the effect of the stimulus along the nerve. We know that the chemical composition of nerve tissue is peculiar and different from that of muscle, gland, etc., and we may perhaps conclude that nerve protoplasm is a peculiar substance the product of the metabolic activity of a peculiar kind, and that by virtue of the preponderance of this substance the power of irritability is heightened in such tissue. No certain method of distinguishing this peculiar compound histologically is known, and hence we cannot trace the evolution of nerve quite as satisfactorily as we can that of muscle, but areas of specially irritable cells usually furnished with long processes are recognized in cœlenterates and even sponges as nervous in function. The tubular form of a nerve fibre is the form best adapted for the propagation or conduction of stimuli and in very low animals, *e. g.*, the annelids and even the medusæ nerve fibres exist.

But the irritability of nerve fibres is not the only or the most specialized case of this function in the frog's body. The nerves travel to all parts of the body, and place all organs in subjection to the will of the animal, or at least, to the central nervous system. But between every surface nerve and the organs affected by it, the spinal cord or the brain intervene as a controlling centre. Here are located the irritable cells or ganglion cells of which the nerve fibres are physiologically, and, perhaps, also histologically extremely produced elongations. These cells are always large bodies with a large spherical nucleus. The body of the cell is globular, but drawn out into a few or many protoplasmic processes, which are directly continued into the protoplasm of the nerve fibre. The disturbance of the fibre reaches and stimulates the cell. The cell is so much more highly irritable that a greater disturbance is aroused in it. This, then, in turn, irritates all the outgoing fibres in connection with the cell. It is thus that the muscle is reached and moved in the experiment referred to above.

The mere nerve fibre of the frog, sensitive as it is, is not sensitive enough to be disturbed by so slight a difference as that between green and blue and red light, or to be excited by the shadow cast by a fly, and hence in so perfect a body as that of the frog, we find additional structures attached to the terminations of nerves going from the surface of the body to the centre for the purpose of receiving extremely feeble stimuli and impressing them upon the nerves. These are called end organs. Some end organs, *e. g.*, of touch, are not themselves peculiarly sensitive, but only act as collectors or, as it were, focalizers of weak stimuli, which, by them, are aggregated in sufficient strength to stimulate the fibre; others, *e. g.*, retinal cells, are, perhaps, peculiarly sensitive in themselves, and after having been stimulated, stimulate the fibre in connection with them. But the mode of action of the end cells is not yet sufficiently understood.

As a result of its specializations of irritability and the possession of suitable organs and tissue, the frog is placed in very close relation with his surroundings, and can care for his body in a wonderful degree. A frog carefully decapitated so as to leave the cerebellum unharmed, can jump as well as a frog in perfect health, but he will not jump until he is actually touched; too late, perhaps, for self-preservation, but a frog with all his powers will jump before he is touched, and, perhaps, long enough before to escape capture. The headless frog can catch a fly if it touches his nose, but the perfect frog catches a fly in the air several inches distant.

We thus look upon the nervous system as a vast number of specially irritable cells peculiarly arranged, which co-operate to manage all the parts of the body for the advantage of the whole.

These tissues in the case of every individual frog are the product of asexual reproduction from a few embryonic cells, the primitive nervous cells, and they are thus like the protozoa in a mode of reproduction, as well as in the power they have specialized. Powers of motion they seem to have entirely abdicated, but metabolic power they have retained, for they can construct from their food, the blood, the peculiar chemical compounds of their own substance, and they can regulate and control the oxidation of the tissue.

We may then conclude that the nervous tissue, like the motor tissue, is made up of cells which obey the general laws of cell life—which resemble all cells in sundry particulars, but which have become very peculiar in form and function by reason of their high specialization of the single function of irritability. Very much remains to be said about the biology of nerve tissue, and very much more remains to be found out. We have not space now to consider the conditions of irritability, its heightening or lowering—the effect of too frequent exercise of the function, effection, effect of drugs on it, and many other inquiries, for we propose only to point out here that the frog is a cellular aggregate.

*Résumé.*—We have now examined the frog's skin, his motor tissue, and his nerve tissues, we find them all to be cellular aggregates, all with certain common properties, and other special or peculiar ones, which, however, are not peculiar in kind but only in degree. We could in the same way examine glands, bones, and other parts, and in every case we should learn that protoplasmic cells are the active units which do the work of these organs, and whose exertions have produced the organs themselves.



### A Proposed New Desmid.

By WM. N. HASTINGS,

NASHUA, N. H.

GONATOZYGON ACULEATUM, *species nova*, Hastings. Cells long, cylindrical, ten or more times as long as wide, free or two to six or more catenate; ends of cells slightly dilate and truncate. Cytoderm covered with prominent aculeate spines. Diameter without spines twenty microns, with spines forty microns. Habitat, Pennichneck Pond, Nashua, N. H., and swamp near Osceola, Mo.



GONATOZYGON ACULEATUM.

The figure represents a magnification of about 425 diameters.

A number of new dismids have been found in New Hampshire, descriptions of which will follow shortly.

NASHUA, N. H., Jan. 15, 1892.

### Notice of Walter H. Bulloch.

By HENRY L. TOLMAN,

CHICAGO, ILL.

The death of this eminent Chicago microscope maker is a severe loss, not only to the Illinois State Society, of which he was for nearly twenty years a prominent member, but to the cause of science at large. He was born in 1835, at Glasgow, Scotland, and lived there until he was seventeen years of age. About 1852 the family emigrated to New York, where Walter learned the trade of tailor with his father. But his innate fondness for mechanical pursuits made him dissatisfied with his prospects, and he was apprenticed to Messrs. Pike & Sons, then a leading firm of opticians and instrument makers on Broadway, New York city. After serving his time he went into business until the war of the rebellion broke out, when he enlisted as a private in the 12th N. Y. volunteers. His term of service, however, was very short, as he contracted a severe cold, which developed into rheumatism, and he was incapacitated from further work, and was mustered out of service. Returning to New York he formed a partnership with William Wales, the well-known maker of objectives, and continued in business there until 1866, when he moved to Chicago. He was very successful and had accumulated considerable means, when his shop and tools were destroyed in the memorable Chicago fire of Oct. 8 and 9, 1871, and Mr. Bulloch sustained a financial loss from which he never recovered. Immediately after this misfortune, he went to Boston and was for a time connected with the late R. B. Tolles, but again returned to establish himself in Chicago. In 1889 he accepted a position connected with the U. S. Coast and Geodetic Survey in the Bureau of Weights and Measures, at Washington, but he chafed under the restraints of an official situation, and after six months' experience, returned to his home

here. Before he left his health had begun to fail, and after his return late in the fall of 1890, he suffered still more. But his indomitable perseverance led him to struggle on. He opened a place at No. 303 Dearborn street, in a very advantageous business portion of the city, and began work again. It was not for long. After struggling with disease for about six months he was compelled to stop forever. He died Nov. 5, 1891, at Elgin, Ill., where he had gone for treatment by Dr. P. Tyrrell. He leaves a wife but no children.

Mr. Bulloch was a man of pronounced character and indomitable energy and perseverance. To those who did not know him well he appeared brusque and sometimes even overbearing, but his numerous friends soon learned to appreciate his straightforward manner of expressing his views, his pertinacious but just demands for a proper recognition of his rights, and his outspoken criticism of what he deemed erroneous in the theories or opinions of others. In his business he was conscientious and painstaking to a fault. Often when making an instrument or piece of apparatus to order if he saw where there was room for improvement he would spend hours or days in experiments, perhaps wasting the results of all his previous labor, refusing to slight his work at any cost. Whether it was the simplest accessory or the finest microscope stand, nothing was allowed to leave his shop until it was as perfect as his trained hands could make it. His reputation was more than money, and he lived to see it world-wide. Besides being a member of the Illinois State Microscopical Society, he was a member of the Chicago Academy of Sciences, the American Academy of Sciences, the American Society of Microscopists, and of the Royal Microscopical Society of London. His death leaves a gap in the rank of scientific workers which can not easily be filled.

### Apparatus for Controlling Living Organisms Under the Microscope.\*

By E. A. SCHULTZE,

NEW YORK, N. Y.

Any one at all familiar with the microscopical study of living organisms will have met with the difficulty of making a satisfactory examination on account of the globular shape of the liquid containing the culture. It is well known that, in order to bring the objects to a full state of development, the water, especially in the case of algæ, must often be changed. In doing this it is in most cases difficult to prevent the algæ from changing their position under the cover-glass. Consequently, a filament under observation may be lost to view. Sometimes, when a too sudden evaporation is feared, the volume of the drop must be increased to such extent that the high-power objectives, and especially the homogeneous immersion lenses, can only be used on those filaments which lie nearest to the cover-glass.

The apparatus described obviates this difficulty, its construction admitting of a constant flow of water; and it answers the purpose in every particular. Two strips, of equal length and breadth, say, one inch long

\* Abstracted from an article by Dr. J. Von Klercker, *Zeitschrift fuer Wissenschaftliche Mikroskopie*, vol. II, page 145, and printed in the *Journal of the N. Y. Microscopical Society*.

and one-quarter of an inch wide, cut from the ordinary square, thin cover-glass, are cemented to a slide with Canada balsam, as seen in view A, at l. l. The object is now placed in a large drop of water between these two strips, under a one-inch square cover-glass, and the entire capillary space may be filled, if necessary, by adding a few more drops of water.

Two short strips of linen, s. s., are now inserted, one at each end, and are held in position by two rubber bands, passing over the cover-glass and around the slide. In order to secure a flat surface on the under side, the slide is now cemented to another slide by means of two pieces of wax, equal in diameter to that of the rubber bands.

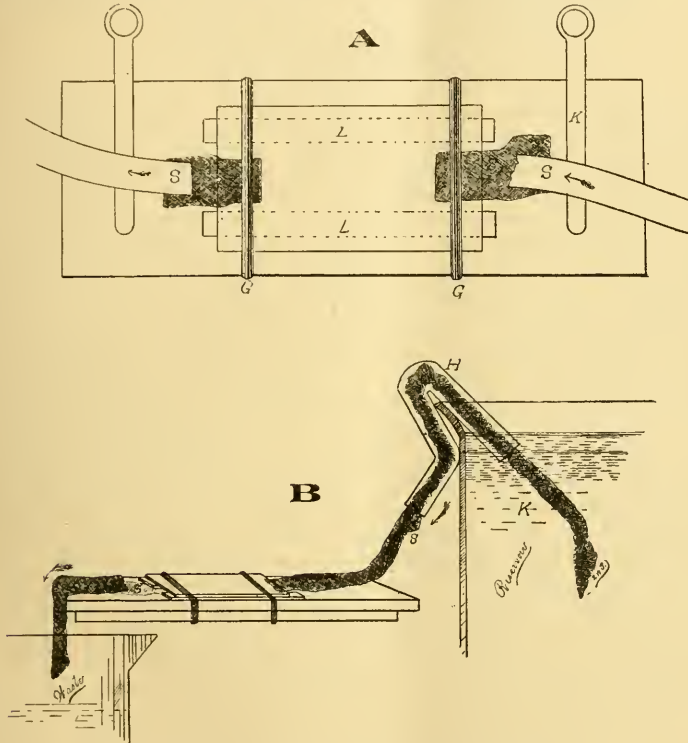

APPARATUS FOR CONTROLLING LIVING ORGANISMS.

A glass, shown in view B at  $\kappa$ , reaching about three inches above the stage of the microscope, is filled with water, and a glass siphon inserted, the shorter arm of which has a much smaller opening than the longer. After filling the siphon with water, a strip of linen is gradually forced into the longer arm, till the flow of water is reduced to dripping. The linen strip is now cut the required length, and connected with one of the short pieces at the side of the cover-glass. The water glass may be covered to exclude any particle of dust. In this way a constant and steady flow of water is secured. The overflow is carried, by means of another linen strip, from the opposite end of the cover-glass into a small receptacle ("waste" in the diagram) at the foot of the microscope.

The following are the advantages of the apparatus :

1. A constant flow of fresh water, which may be regulated by the linen strip in the siphon. The water, while running, keeps saturated with oxygen by means of the linen strip extending from the mouth of the longer arm of the siphon. This strip also acts as a filter, retaining any particles of dust that may have accumulated in the reservoir.
2. The height of the capillary space between the cover-glass and the slide being only of the thickness of an ordinary cover-glass, all objects may easily be seen with an immersion lens.
3. The immersion fluid may be removed from the cover-glass without disturbing the objects.

### Interesting Items on Diatoms.\*

By CHAS. F. COX,  
NEW YORK.

**Assorting.**—If we take the product of our filter and place dippings from it under the microscope, we shall at first experience some embarrassment because of the multiplicity of objects presented to our view. There will be an abundance of sand and other amorphous and inorganic substances, and amongst these are likely to be scattered fragments of leaves and stems of exogenous plants, bits of linen, cotton or woollen threads, and various other articles of extraneous origin. Prominent, however, because of their bright color and considerable size, will appear the long-jointed tubes of a few of the thread-like aquatic weeds, while deep down through the film of water we shall discern two similar and yet somewhat different sorts of diminutive bodies, which are sure to fasten our attention by their very pretty and symmetrical forms. The one kind is of a deep green color, the other of a thin reddish or brownish-olive hue; and both will exhibit some differencing of their internal substance into denser and more attenuated parts, with here and there open, oily-looking spots. The dark green bodies appear as single capsules, narrowed, if not pointed, at each end, and floating free or else as loose aggregations of similar flattened cells, forming either rosettes or lace-like mats of various patterns. The brownish bodies will be found either as narrow rods, laid side by side in long bands, or joined to one another by their corners so as to form zigzag lines, or else as disconnected individuals with a very striking resemblance in shape to miniature skiffs or boats. If we make use of some other source of supply than our Croton-water faucet, we may obtain a much greater variety of forms in both the classes of objects referred to, though we shall not fail to notice a certain parallelism in the morphology of the two families, which may easily cause us to think them but one. They are, however, quite distinct, as we shall see. These forms which I have spoken of in this particular case as decidedly green in color (although this is not a decisive characteristic throughout the family) are known as *Desmids*. Those which I have described as being of a brownish hue are *Diatoms*.

**Distinction between Desmids and Diatoms.**—But now, if we look more closely at our desmids and diatoms, we shall discover that the latter have a very rigid, hard, and almost indestructible carapace or shell, while that of the former is hardly more than a stiffened membrane

\* Paragraphs extracted from an address by Chas. F. Cox, and entitled, "What is a Diatom?" delivered December 18, 1891, before the New York Microscopical Society and published in the Society's journal for January, 1892.

which is with difficulty discerned at all. In the diatoms the enclosing case will prove to be a solid deposit of nearly pure silica; but in the desmids it will be found to be a semi-flexible film slightly infiltrated with carbonate of lime. This is an important distinction, which forms the basis for a sharp separation of the two groups of forms. As regards the particular specimens we are supposed to have under immediate inspection, however, we shall by this time have observed a difference which to most minds will constitute a clearer demarcation than could be established by any other criterion; and that is that our desmids are apparently quite passive, while the little boat-shaped diatoms actively glide about with a seemingly well-defined purpose.

**Locomotion.**—You will need to abstain from generalizing too far and too fast in this connection, for all diatoms do not possess this power of locomotion, since not only are some of them united to one another, as we have seen, but many sorts are attached to plants and other fixed objects, although the theory has been advanced that all diatoms are, at one time or another, free and migratory. On the other hand, while desmids are never permanently anchored, locomotion is not a prominent characteristic of even the solitary forms, because, while it is pretty general throughout the group, it is too slow to attract attention, and, when observed, has not that appearance of voluntariness which is exceedingly striking in the movements of the free, boat-shaped diatoms. When you have a specimen of the latter under your microscopically-aided eye, you will see it slide over the bottom of your artificial pond without discernible machinery but with very appreciable force and considerable speed. If it meets an obstruction which is not too large, it pushes it aside, but, if too heavy, it halts a few seconds and then reverses its invisible engine and changes its course.

**The diatom possesses a body of plastic substance called protoplasm.**—This, upon close examination, we easily learn to be the case. Very simple methods of investigation show that every frustule (as each individual cell is called) is in reality a glass box enclosing a semi-fluid, nearly transparent, but somewhat granular material, containing, besides the oily-looking spots or vacuoles to which I have before referred, more or less of a yellowish or brownish-green substance, which gives its general color to the whole organism. There is reason to believe that the semi-fluid material also forms an enveloping layer on the outside of the siliceous carapace of all diatoms, and in many instances a similar glycerine-like matter permanently encloses a whole colony of otherwise separate frustules, which passively spend their existence within its restraining grasp. Now, chemical tests disclose the fact that the colloidal mass within the transparent valves is composed of carbon, oxygen, hydrogen, and nitrogen in proportions and relations which characterize an organic substance, and a great number of converging facts, derived from long-continued observation, go to prove that this substance is the seat of all the changes, chemical and physical.

It is through and by this protoplasm that the diatom responds to the influences of heat and light, that it receives and assimilates its food, that it moves from place to place as we have seen the boat-like specimen in the Croton water doing, that it grows and reproduces its kind. It was because of its agency in these matters that Prof. Huxley called protoplasm “the physical basis of life,” though its name really means

“primary formative matter,” and Beale’s designation of it, bioplasm, more definitely expresses the idea of its being a *life* plasma.

In *Nitella*, *Valisneria*, or *Anacharis* you may see the colorless current circling in every cell, building and unbuilding with a chemistry beyond our ken, and in all the higher animals it seems to be the matrix in which are fashioned the tissues and the bones, the source also of the contractility of the muscles and the sensibility of the nerves. In your own warm blood you will find protoplasm, in the form of the “white corpuscles.”

**Animal or Vegetable?**—How are we to tell whether the diatom is animal or vegetable? Here is another of these points at which ignorance has been accustomed to think itself wise, but where wisdom has come to admit itself ignorant. Prof. Huxley set forth the situation of this matter most admirably in his lecture entitled “The Border Territory between the Animal and the Vegetable Kingdoms,” and there has been no essential change in the case since he therein stated it. Naturalists had been in the habit, from the days of Cuvier, of relying upon four proofs which they considered conclusive of the animal nature of any organism. These were (1) the possession of an alimentary cavity, (2) the presence of muscles for locomotion and of nerves for sensibility, (3) the existence of nitrogen as a constituent element of the body-substance, and (4) the exercise of the function of respiration—the absorption of oxygen and the exhalation of carbonic acid. But all of these distinctions have been shown to be subject to so many exceptions as to destroy their value as tests.

The difficulty with this matter, as well as with the subject of vitality, is that we look for single distinguishing signs when we ought to take into consideration a whole series of phenomena at once. Thus life would prove to be not an entity, an essence, or even a principle, but rather a *process*. In like manner, the criterion of animal life, as distinguished from vegetable, would not be found in assimilation, sensation, self-motion, or any other one thing, but in a group of actions and attributes, by their sum-total turning the scale to the animal side.

As far as we know, the diatom protoplasm has no proclivity for cannibalism, as all animal protoplasm seem to have. Taking this negative quality for what it is worth, and adding it to the general sum of the diatom’s other characteristics which common sense somehow recognizes as belonging to the vegetable kingdom, we arrive at a decision that the object of our consideration is a plant and not an animal.

**Classification.**—Having made up our minds that diatoms lie within the boundaries of the vegetable kingdom, we shall have no difficulty in referring them to that sub-kingdom which includes all non-vascular, or, in other words, leafless and rootless plants—called *thallophyta*. In this sub-kingdom is the well-known class *Algæ*, which embraces all aquatic thallophytes, and to which therefore the diatoms must belong. Indeed, they constitute a very important sub-class of algæ, which derives its name from them—the *diatomaceæ*.

The diatomaceæ themselves get their name from the Greek word *διατομος*, which means *cut through*, *cut in two*, or *cut up*, and which was applied to them with reference to the bead-like manner in which the individuals of many genera cling together in fragile strings.

**Gemination.**—Reproduction by self-division is not at all peculiar to this sub-class, nor even to the vegetable kingdom. Animals, as well as plants, commonly multiply by simple fission, and amongst the true infusoria, or animalcules, the operation is so rapid that, in some genera (as, for example, the vorticellæ), one may witness within an hour the complete bisection of a single vigorous creature into two lively counterparts. The process in the plant-world is generally much slower, but it passes through essentially the same steps and may be traced with equal clearness and certainty. In fact, at their foundation, all modes of reproduction are but forms of fission—the division of one into two or more—and the ultimate nature of the process is not changed by the fact that the resulting two are often so dissimilar in size and other attributes that we feel bound to regard one as the parent and the other as the offspring. In other words, it is none the less fission because it takes the form we call budding.

**What is an Individual?**—Continuous gemination gives rise to very interesting and complicated relations which involve another insoluble biological puzzle—as to what constitutes an individual. When one regards the cell-units, with their circumscribed and apparently complete cell-functions, he is disposed to credit them with the real individuality; but when he looks to the mutual interdependence which usually exists between the cells which retain a physical connection with one another, he inclines to expand the idea so as to include all the members of any communal aggregation, if he does not stretch it still further, as some authors do, so as to cover all the products of fission or gemination within a continuous series, whether remaining united or not. In such cases, however, as those of the filamentous and flabellate diatoms, in which there is no absolutely necessary connection between one cell and another, and where there is no known reason why any single frustule would not go on in the performance of all essential functions if it were entirely separated from its sister cells, we seem to be quite justified in regarding the type as physiologically unicellular, even though the anatomical units are not always physically solitary or free. There is at least no evidence that those diatoms which are found within a *thallus* (as already mentioned) have anything more than a mechanical connection with one another, and vital independence is after all the best test we have of their actual individuality.

**Self-Division.**—In the diatoms, the first indication we have that self-division is about to take place is the appearance of a sort of uneasiness within the nucleus and the formation of a constriction about the middle of the endochrome. This is at the beginning a mere indentation of outline, but it gradually deepens and deepens until it finally results in the cleaving of the endochrome in twain. It is one of the most impressive sights a man can witness.

**Mode of Motion.**—Having once seen this manifestation of efficient energy within the diatom-shell, we shall not much wonder that the free frustules move from place to place. We may, however, entertain a lively curiosity as to the direct means by which their locomotion is accomplished, although, in the present state of knowledge, I am sorry to say, that curiosity cannot be satisfied.

The motion of the free diatoms is like neither the quick and nervous swimming, effected by cilia or flagella, nor the slow and measured

crawling, performed by pseudopodia. It is, in fact, a somewhat jerky sort of glide. There are, nevertheless, advocates of the existence both of cilia and of pseudopodia as the means of the diatom's propulsion, although no certain glimpse has ever been obtained of either kind of organ.

**Remains.**—From the architecture of the typical frustule it may be inferred that whenever, by any means, its organic material is destroyed, its two valves will fall apart, and that, if the diatom is in an advanced stage of incomplete subdivision, it will break up into four valves and two hoops. To such constituent parts the microscopist commonly reduces his diatomaceous material, by treatment with acids, for purposes of permanent mounting and preservation. Nature, also, is constantly removing the soft and perishable endochrome from diatoms which have run their life's course, and is steadily depositing their nearly indestructible remains at the bottom of almost every permanent body of water. As diatoms have swarmed in river, lake, and sea for countless ages, at least since the glacial epoch, their flinty shells have come to form beds and strata of very considerable extent in numerous parts of the world. The fresh-water, salt-water, and brackish-water deposits are very dissimilar in character, as are also the prevailing forms of different periods.

**Deposits.**—Amongst the largest and best-known deposits are that which underlies the city of Richmond, Virginia, and its vicinity, and the one near Virginia City, Nevada. The "Richmond earth" forms a stratum of from 8 to 30 feet in thickness, lying near the surface and extending throughout the eastern part of Virginia and portions of Maryland. There is some reason to suppose that this extensive deposit is related to if not actually connected with deposits recently discovered, at depths of several hundred feet, at Atlantic City and other points in Eastern New Jersey. The forms prevailing in these deposits are of the kinds peculiar to salt water, and their accumulation, in these immense beds of wide extent and great thickness, is evidence of a long-continued submergence of the regions in which they are found beneath an arm of the sea.

The Nevada deposit is of very pure fresh-water forms, and was laid down in one of two great intra-glacial lakes, which geologists tell us were nearly as large as Lake Superior, one of which filled the Utah and the other the Nevada basin. The Nevada deposit has been worked commercially for a number of years, as the source of the polishing-powder which goes by the trade name of "Electro-Silicon." This and other diatomaceous earths are also employed to some extent, I believe, to form an absorbent base for certain high explosives. Indeed, very many of these earths are valuable articles of commerce. They furnish silica in a finely-divided form, suitable, amongst other things, for the manufacture of the silicate of soda or of potash—otherwise known as "soluble glass"—which is an ingredient in the glazing of pottery, in artificial stones, and in certain cements and paints.

**Growth of our Knowledge of Diatoms.**—Under the microscopical powers of early days the valves of all but the very largest species appeared as simple in structure as if made of perfectly plain transparent glass. Some of the coarsest, particularly the discoidal forms, displayed upon their surface a dotting or embossing, with occasionally a rayed or more complicated pattern. A few of the angular forms presented a



structure of coarse hexagonal netting, while some of the elongated and boat-shaped kinds were seen to be possessed of stout ribs running at right angles to the meridian line, or keel. At a later period, not only was the mere magnifying power of the microscope greatly increased, but, what proved to be of much more importance, methods of illumination were devised which enabled the observer to throw beams of light of different sorts upon the object at various angles of incidence. By this means it was discovered that lined shadows were cast upon the surface of valves which had previously appeared entirely smooth and clear. It was found that these shadows are caused by shallow furrows running, not only lengthwise of the valve, but also at right angles to the median line or even obliquely to it. For a long time it was regarded as the acme of manipulative skill to display this simple system of striation upon the larger and coarser forms upon which the distance between the lines ranges from the 20,000th to the 50,000th of an inch. By slow degrees the microscopist attained to the ability to show at once two or more systems of lines, producing a cross-hatching with square, lozenge, or hexagonal interspaces, and at about the same time it began to be possible to discern upon some of the smaller specimens a striation having only the 80,000th or the 90,000th of an inch between lines. This was the maximum of attainment about thirty years ago. Since then progress has been slow in this department of microscopy and each small step achieved has caused a disproportionate amount of labor and discussion. But after a while an advance was made to the resolution of lines less than the 100,000th of an inch apart, upon such fine species as *Frustulia saxonica* and *Amphipleura pelucida*, and the methods which rendered this progress possible brought double systems of lines to view on those diatoms which had before shown only one system (like *Surrirella gemma*), and raised to the rank of well-defined dots the interspaces in the previous cross-hatching upon the more robust species, such as *Pleurosigma angulatum*. Then it was that microscopists ventured on the important generalization that the typical form of marking, throughout the whole sub-class of diatomaceæ, is a series of dots, oftenest arranged in formal rows, but sometimes scattered irregularly over the shell.

**Easily Obtainable.**—To him who has access to running brooks, quiet ponds, or the greater lakes, a range of several hundred species or varieties is open. To the explorer of brackish estuaries and the deep salt sea, other hundreds offer themselves. To the one who can dig into the extensive deposits of their fossil remains, still other hundreds present their interesting forms. But even to us who dwell within the barren walls of a great city an unstinted supply of certain kinds is always close at hand, for the simplest of filters applied to a Croton-water faucet will, in a few minutes, furnish at least a half a dozen species; and this will be our most convenient source of supply.

---

Ernest Wilhelm Brucke, Professor of Physiology and Microscopic Anatomy, Vienna, died Jan. 7, aged 72. Member of the Academy of Sciences and professor in Vienna since 1849.

## EDITORIAL.

*All communications for this Journal, whether relating to business or to editorial matters, and all books, pamphlets, exchanges, etc., should be addressed to American Monthly Microscopical Journal, Washington, D. C.*

**Too Scientific.**—We always feel mortified when we receive a letter in which the writer says that he thinks he will discontinue his subscription because the periodical is “too scientific.” Just what such people would say if their services were pronounced “too good” or “too accurate,” we may easily imagine. When called upon to explain, they usually say that by “too scientific” they mean too much obscured by technicalities and unfamiliar language; and so we say that we feel ashamed to have our work pronounced as containing too much language which is unintelligible to the masses. Scientific men often retort; so much the worse for the unskilled and unthinking masses. But we stand on a middle ground between these two groups of people.

The highest art is simplicity; the highest culture is simplicity; and the scientist who scorns simplicity and deliberately seeks to cover his knowledge with technical terms, deserves the scorn of the people whom he seeks to bewilder. The scientist who fails to try earnestly to state his knowledge in terms intelligible to the greatest number of people should be pronounced careless and unsympathetic.

But from that extreme behold this. We sometimes see people trying to write for amateurs and with what results! They use words, words, words, crowding twenty lines with what could be said in seven. They even use bad grammar and deplorable rhetoric in their efforts to make their language not “too scientific.” We have seen striking examples of such well-meant effort and have heard it pronounced “bosh.”

What, then, shall we do? As for us, we shall not use technical terms and rare words if we can help it, but oftentimes it is a necessity. We shall not dilute our facts with twaddle and silly words, but we shall sometimes omit long and very technical descriptions, and, perhaps, hurt the feelings of contributors thereby. We shall tone down to common English what we present so far as possible, and we shall insist on good grammar. To those subscribers who can see simplicity only in what is so cheap as to disgust all scholarly people, we must bid a sympathetic farewell. We cannot supply the place of elementary knowledge. There are dictionaries and books of first principles every where, and we must assume that our friends are willing to refer to them.

With our new plan, however, of introducing many illustrations much will be done to clear up the troublesome things and to bring microscopy within the understanding of all who will study.

Contributors are invited to send us illustrated articles as frequently as possible, and upon subjects of as wide interest as possible.

**Prompt Publication.**—Our January number has been provokingly delayed by several causes, but the February number comes out at the middle of that month. Hereafter the Journal will be issued promptly on the fifteenth day of each month. Subscribers who do not receive it soon after that date may send a postal card so stating, and the cause of non-receipt will be investigated.

Those who prefer to have untrimmed copies for binding, and will send a postal card so requesting, will be supplied with uncut numbers.

## MICROSCOPICAL APPARATUS.

Camera for Micro-photography.—We are indebted to a writer

in *Science-Gossip*, Mr. D. W. Barker, for a description of his "home-made" apparatus shown in the figure.

A wooden table is made somewhat wider around its top than the front of the camera, and contains near the centre an aperture through which to project slightly the microscope tube. After removing the lens from the camera, place the latter on the table with its front downward. Place the microscope underneath and close the aperture to rays of light by means of the small silk sleeve *a*. A good lamp is to be used for illuminating. Focus roughly by hand, and then finely on to the ground glass of the camera, by means of the fine adjustment screw *b*. Use a large diaphragm on the microscope base. Expose in the

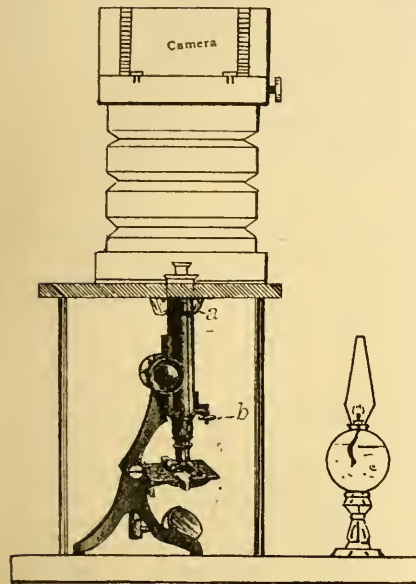

ordinary way. A little practice will soon show the right exposure to be given, always using the same lamp. A small beading round the top of the table holds the camera firmly.

**A nice sterilizer.**—In all bacteriological work, sterilization or the destruction of all germs in apparatus used is absolutely necessary. Dry heat is often employed. Koch invented a steam-chest, the description of which may be found in Ball's "Essentials of Bacteriology." In this country there is a steam-cooker made of copper, which is sold for cooking meat and vegetables, but which has been found to make a nice sterilizer. The accompanying figure presents a good idea of it. It may be heated by the Bunsen burner or upon a stove. With the single Bunsen a temperature of  $212^{\circ}$  F. ( $100^{\circ}$  C.) may be obtained in from 6 to 10 minutes.

A is the reservoir containing cold water which passing through the openings reaches the boiler B, where owing to its shallowness the water becomes hot very rapidly. As fast as the steam forms it rises through the aperture C and passes into the chamber D, completely envelop

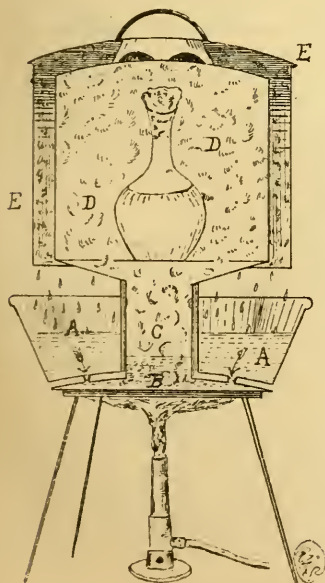

ing the flask. The cover E is in the form of a hood, beneath which steam may escape. The space between the hood and the chamber averages about an inch, thus keeping the latter enveloped with steam on the outside as well as filled within. This takes the place of felt, which is used in some other sterilizers. The water which forms inside the hood from condensation drops down into the tank A. This condensation takes place on the interior surface of the hood but not on the exterior surface of the sterilizer.

The apparatus without stand is 10 inches deep and 9 inches in diameter, and holds about 5 gallons. It may be used for disinfecting as well as for sterilizing and for cooking.

The portability of the apparatus, its simplicity, the ease with which the water may be replenished without discontinuing the process, its compactness and varied utility make it worthy of commendation.

### MICROSCOPICAL MANIPULATON.

**Demonstrating the Influenza Bacillus.**—Dr. Pfeiffer of the Koch Institute manipulates the sputum of influenza patients by first sterilizing and cleansing it by Koch's methods, and then treating it with Ziehl's solution or Loeffler's hot methylene blue. The two extremities stain more intensely than the intervening parts causing some resemblance to diplococci and to streptococci.

The bacilli may be then seen under the microscope, being more copious in the mucus and cells of sputum—in the latter, often degenerate. One of their characters is immobility. They are much smaller than any other known micro-organism.

**Determining Magnification.**—A fellow of the Royal Astronomical Society writes to the *English Mechanic* as follows:

The magnifying power of a microscope is never found by calculation, being always determined experimentally.

A micrometer ruled to 100ths and 1000ths of an inch is placed on the stage and carefully focussed. Then a rule divided to 10ths of an inch is held parallel with it at a distance of 10 inches from the other eye and shifted about until the micrometer lines coincide with divisions on the rule. If a division of one-hundredth of an inch corresponds with  $1\frac{1}{2}$  inches on the rule, the microscope magnifies 150 diameters.

A more accurate way is to project the image of the micrometer, by means of a camera lucida, 10 inches from the eye and measure this with compasses ten times along the rule. If one of the thousandths divisions on the scale repeated 10 times along the rule measures 6.25 inches then one such division measures .625-inch and the microscope magnifies 625 times linear. The very thickness of cover-glass alters the magnifying power, as does of course any alteration in the length of tube.

The following five items are from the *Observer* of December:

**To detect air bubbles.**—The small bubbles which get under the cover-glass while mounting may be detected by laying the slide on a slip of dark-colored glazed paper. View with a lens if necessary.

**To clean objectives.**—Use small pieces of Japanese filter paper, which costs but a few cents, for this purpose.

**Mounting opaque objects.**—Use a piece of postal card covered with colored tissue paper, laid under the slide, or on a B. and L. glass stage under the slide carrier. This obviates making a back ground on the slide for opaque objects.

**To mount sand dry.**—A film of gelatine is placed on a slide with asphalt centre after it has become thoroughly dried. Such slides may be kept on hand ready for use. Breathe on the slide and cover with dry sand, removing the excess. With the turn-table ring in a cell of the hottest paraffine. As soon as the cell is deep enough to hold the cover seal it down with paraffine and ring it with gold size. Use a good quantity and touch both cover-glass and slide. When thoroughly dry, ring it again.

**Confining living forms.**—A bit of thin cloth (such as a veil) contains so many meshes that it becomes practically a cage for small forms. Silk bolting cloth is excellent, owing to the way it is woven, because it retains its shape even when cut into small pieces and because it can be obtained of any desired size. If the mesh is a trifle smaller than the objective used, the captive cannot get out of the field of vision. For insects with antennae this will not answer, but another method is better. Put the specimen with a very small quantity of water in the glass of a live-box. Lower the cover until it touches the drop. Then withdraw it until a pool of sufficient diameter is formed. This pool being without sides, there is no danger of injuring the specimens. If it is too deep when reduced to the right diameter or if the water leaves the cover-glass before it is sufficiently contracted, the quantity of water should be reduced.

**Mounting Tubercle Bacilli.**—In the rapid method of staining tubercle bacilli, the sputum may be dried directly on the slide, and the staining, decolorizing, and counter-staining may be performed on the slide. Mount in Canada balsam or glycerine. This is more rapid than the method in which the sputum is placed on the cover-glass.

**Cements.**—Do not buy cements in bottles with cork stoppers. Insist on glass stoppers. The cement will hold the cork fast to the bottle after it has been out once and got soiled a little. The cork and your patience will then be ruined. Vaseline placed on the stopper will reduce the tendency to stickiness.

---

## BIOLOGICAL NOTES.

---

**Sweet Potato Blossoms.**—A rare and interesting phenomenon, that of a field of sweet potatoes being in full blossom in the fall, was recorded by Prof. Halsted in the last Torrey Bulletin. The field was located in the southern part of New Jersey.

**An Insectivorous Plant.**—At the Royal Gardens in Edinburgh is a large insectivorous plant, of the genus *Roridula*. The plant is a native of Tasmania. It is a branching bush, with filiform leaves, more slender than those of *Drosera*, and, like the latter, furnished with glandular hairs with which it captures flies. The glandular hairs of the leaf of *Drosera* will not move on contact with inorganic matter, but they will contract upon a minute piece of fresh meat in the space of twenty seconds. The insects most abundantly captured by *Drosera* are ants.

**Duration of Life.**—The age of various animals is said to average in years as follows :

Whale .....	1,000
Swan, parrot, raven.....	200
Elephant, camel, crocodile, tortoise, eagle.....	100
Carp, geese.....	75
Lion, beaver.....	50
Stag, pellican, pike.....	40
Horse, ass, ox, hawk.....	30
Tiger, leopard, jaguar, hyena, chamois, swine, crane.....	25
Rhinoceros, deer, wolf, cow, peacock, goldfinch.....	20
Monkey, baboon, linnct. sky-lark.....	18
Fox, llama, nightingale, salmon, cod.....	15
Hen, pigeon, blackbird, red-breast starling.....	12
Hare, sheep, thrush, eel.....	8
Squirrel, rabbit.....	7
Queen bees.....	4
Wren.....	2

**Bumble-bee in New Zealand.**—The bumble-bee was sent to New Zealand in order to secure the introduction of red clover. This has been accomplished, the bee fertilizing the blossoms. Curiously, the bumble-bee does not visit the indigenous plants, and it has multiplied extraordinarily, and does not hibernate at all.

**Preserving Botanical Specimens.**—At the Paris Museum of Natural History 30 grains of salicylic acid to one quart of water are used for the preservation of specimens in their original form and color.

**Diatom Multiplication.**—Division takes place in not far from 24 hours and continues with such rapidity that a single frustule is capable of producing a thousand million progeny in a single month. It has been claimed that division occurs in from 3 to 6 hours instead of 24. Moisture and light only are necessary for their reproduction.

**Watermelon Juice** contains about  $3\frac{1}{3}$  per cent. of sugar,  $2\frac{1}{2}$  per cent. of levulose, and  $\frac{7}{10}$  per cent. of glucose or dextrose.

**Biological Specimens** lose color if put in alcohol, fall to pieces easily if kept in glycerine, and their tissue disintegrates in carbolic acid.

## DIATOMS.

**Diatoms from new localities.**—Mr. J. D. Hyatt, of New York, has found marine forms in the filter beds of the Pokeepsic City Waterworks.

As noticed in our July number, Mr. K. M. Cunningham, of Mobile, Alabama, has discovered a deposit of diatomaceous material on the west bank of the Mobile River. It is in tidal marsh mud taken from three to five feet below the surface, and has probably not been seen heretofore by diatom hunters. The vegetable growth, mostly marsh grasses, rests upon a stratum of a very soft, oozy mud, through which a pole may be readily pushed for a depth of six feet. When withdrawn, the soft mud is scraped off and subjected to the usual treatment for the removal and concentration of diatoms. This mud proves to be of unusual richness in variety of micro-organic remains. Associated

together are found marine and fresh-water species of diatoms, several interesting varieties of sponge spicules, very numerous tests or carapaces of fresh-water rhizopods, and several species of marine foraminifera. Also there may be seen varieties of pollen grains or spore capsules, and many plates of mica. On two slides Mr. Cunningham has shown selected rhizopods, to be viewed strictly by polarized light, and two slides of deposit strewn so as to show the various associated micro-organisms by polarized light. These slides have no cover glasses, but are covered by a thin film of mica, with the object of intensifying the brilliancy of the prismatic effects. Under this arrangement we are provided with a kaleidoscopic effect of color, produced by the polarized light when the polarizing prism is revolved.

The diatoms are being washed by Dr. Geo. H. Taylor, of Mobile, without use of acids. He is now engaged on the reduction of a large bucketful of the deposit. The diatoms indicate an aggregation of about fifty marine and fresh-water species—*Actinocyclus Ehrenbergii*, *Campylodiscus crebrosus*, *Nitzschia circumscissa*, and *Terpsinoe musica*. Another interesting feature is that *Triceratium favus* is absolutely absent, and that *Cymatopleura elliptica* and a pretty *Acanthes* are seen in every lot of earth.

The material makes elegant balsam or dry mounts for condensed surface illumination for binocular. It is of unusual interest before acid treatment, as it shows a fair mixture of a wide variety of rhizopods, sponge spicules and diatoms, not to mention a great variety of transparent plant tissues of great diversity of cellular structure, with scales of mica, which polarize very prettily.

---

## BACTERIOLOGY.

---

**Discovery of the Influenza Bacillus.**—Koch is authority for the announcement that this bacillus has been found by Dr. Pfeiffer of the Koch Institute, and independently by Dr. Canon of the Moabit Hospital in Berlin. The Berlin correspondent of the London *Lancet* describes Pfeiffer's work thus:

“He examined the sputum of influenza patients, first preparing it by staining. A large number of micro-organisms then became visible under the microscope, and it soon appeared that they were mostly of the same kind. This was always the case with the sputum of patients suffering from influenza alone. When the disease was accompanied with other pulmonary disorders, other bacteria were also visible in the sputum. The sputum of a large number of patients suffering from pulmonary and other diseases, but not from influenza, was examined, but no micro-organism possessing the qualities which characterized that found by Pfeiffer in influenza was formed. A reason why this bacillus has so long escaped observation is that it is far smaller than any micro-organism heretofore known.

“Dr. Pfeiffer next cultivated the bacillus in pure cultures, and here another explanation of the lateness of its discovery came to light. The colonies were so small that they could easily be overlooked. At first they were visible only under the magnifying glass. Glycerine agar was the best nutritive medium. The most characteristic thing about this

bacillus was that the colonies did not flow together but remained separate. The results of the examination of sputum had been entirely confirmed by post mortem examinations made by Pfeiffer in the bodies of six patients which had died of influenza. In all, the influenza bacilli were found in the affected parts.

“He then tried to produce influenza in monkeys, rabbits, guinea pigs, rats, pigeons, and mice by inoculating the bacilli. He had succeeded on January 7 with monkeys and rabbits.”

Dr. Canon examined the blood of influenza patients suffering from fever under the microscope, and having found organisms previously unknown, compared them with Pfeiffer's new organisms and found them identical. As soon as recovery from fever took place, these bacilli disappeared from the blood, and they were found only while influenza patients were feverish. Their numbers varied considerably. Dr. Canon is satisfied that the detection of this bacillus in the blood of a feverish patient is a sufficient proof of influenza.

It now comes out that Dr. Pfeiffer saw and photographed influenza bacilli two years ago without knowing what they were nor suspecting their meaning.

**Souring of Milk.**—A. L. Treadwell has experimented with milk and electrical discharges and thinks that a slight hastening in the time of souring is produced. But if the milk is first sterilized no souring will result. He thinks therefore that souring is due to the more rapid growth of micro-organisms under the influence of free oxygen generated by the electricity.

**Chemically Pure Water** may contain large quantities of microbes. Lortet has found them in such water from Lake Geneva by allowing them to settle to the bottom. He identified numerous micro-organisms, including the typhoid bacillus. Althoefer uses peroxide of hydrogen for disinfecting such water. He finds that 1 part to 1000 will in 24 hours destroy all germs. This is a harmless and extremely economical method.

**Beer May Contain Bacteria.**—Zeidler found in a beer that had become cloudy what he thought might be *Bacterium termo*. In gelatin along the inoculation track arose dirty yellow granular colonies, and the gelatin liquified after some days. On potato he got a dirty yellowish-brown growth. Alcoholic fermentation in the beer destroyed the organisms. Two other organisms of uncertain character were discovered.

**Carbon Favorable to Growth of Micro-organisms.**—With a Zeiss  $\frac{1}{2}$  oil-immersion lens, Dr. Jeaffreson of Newcastle-on-Tyne, has examined the bronchial secretions from an influenza patient who lived in a very smoky district of a very smoky city; and he found micrococci in unusually large numbers. The finely divided smoke and coal dust entering the lungs is not equally distributed and collects in dense patches. Wherever these patches were densest, there the micrococci were thickest and presented as to form the appearance of zooglæa-like masses. He infers that finely subdivided carbon may favor the development of micro-organisms, and that this may explain the excess of throat and lung diseases in smoky cities.—*Lancet*, Jan. 23, 1892.



## MEDICAL MICROSCOPY.

---

**Prevention of Influenza.**—The discovery of the influenza bacillus described under Bacteriology indicates the great importance to be attached to removing the sputum of patients suffering from influenza. The germs of this disease, it is now known, can be communicated by many of the means by which diphtheria and tuberculosis are transmitted. A three-grain sulphate of quinine tabloid taken daily at breakfast during the continuance of an epidemic is found to be a remarkable preventative of the development of these germs.

**Actinomycosis again.**—At the Pathological Society of London Mr. Kanthack recently reported a case from Madura. A fungus growth upon a hand that had been amputated was placed in ether or chloroform, and afterwards well washed in caustic potash. When examined under the microscope small rounded bodies showing rays were noticed. Outside the ray-like mass was an area of round cells, which in turn was enclosed in a fibrous ring. The reaction to staining was identical to actinomyces.—*Lancet*, January 23, 1892.

**The Microscope in Diagnosis.**—Dr. Ephriam Cutter has an article in the January *Microscope* from which the following data is gleaned:

The microscope is useful for examining the blood, sputum, fæces, urine, skin, secretions, eyes, ears, nose, glands, milk, and vomitus.

The microscope has shown that rheumatism is a disease of the blood first and next of the fibrous and cartilaginous tissues. Without the instrument no certain diagnosis can be made. With it, five varieties can be distinguished: Cystinic, Oxalic, Phosphatic, Uric, and Hippuric.

In rheumatism the heart is generally enlarged, while the microscope shows this to be due to the adhesive condition of the red corpuscles, to the strong and more numerous fibrin filaments and skeins, to blood crystals and to minute clots formed in rheumatic blood.

Embolism can also be diagnosed with the microscope.

**Dust injurious to the Lungs.**—Dr. Wm. B. Canfield, of Baltimore, has found pulmonary diseases to be caused in part by the inhaling of dust, and the microscope to be the best means of diagnosis.

He examined sputum from patients that were suffering from pulmonary symptoms, and the microscope showed the sputum to contain carrier cells in abundance. In all cases these contained pigment, and in some instances the black crystalline coal could be recognized within these cells. This pigment and foreign material have a tendency to collect at the apices of the lungs and are only present at the bases when the dust is inhaled in excessive amount.

In diagnosis, physical signs do not yield as much as the microscope. By the microscope we see the cells containing the dust.

**Trichina** were taken by Dr. M. A. Gottlieb, of New York, from the biceps muscle at the autopsy of an Italian who entered Bellevue Hospital in the spring of 1890, and who died three weeks after, suffering from trichinosis. The Doctor has recently presented mounted specimens to the N. Y. Society.

**Prize Essay.**—The Société de Médecine, Paris, offers a prize of \$300 and a gold medal for the best essay during 1892 on tuberculosis.

### RECREATIVE MICROSCOPY.

**Brownian Movement.**—This remarkable phenomenon of inorganic matter, discovered by Robert Brown in 1827, wherein particles surely not alive and having a diameter of less than  $\frac{1}{30000}$  of an inch move as if possessed of life has been shown by C. F. Fox, of New York, as follows :

“ In 1874 I rubbed up in water a little gamboge, which I confined in a hermetically-sealed cell, and which, for more than fourteen years (as long as the cell remained intact), was brought out periodically to illustrate the fact that “ things are not what they seem.” Numerous other illustrations of this uncertainty of appearances might be drawn from things in sight and above sight, as well as beneath sight ; and it is well to remember in this connection that, broadly considered, motion is an attribute of every form and condition of matter, great or small, simple or combined, inorganic or organized.”

Carmine, indigo, and many finely-produced metals will answer as well. This movement is oscillatory and can be distinguished by the expert microscopist from vital motion. Through this movement we may perhaps some day come to the origin of life, or of vital motion.

**Diatom Material.**—We have some diatom material which will make beautiful slides for exhibition. We will send a small amount to any subscribers who will mount it and return to us a sample slide. When we have received a number of such slides we will report on their comparative merits.

**The Sugar Insect.**—A microscopic insect, *Acarus sacchari*, is often found in raw or unrefined sugar, a recent examination showing 69 out of 72 samples infected, and showing 500 individuals in 10 grains of sugar of one sample. Refined sugar does not contain them. If eaten they do not harm, but if raw sugar is handled the mites work their way under the skin, producing “grocer’s itch.” Refiners are especially liable and should always examine sugar microscopically for this insect. A single female can produce a million offspring in three months. The treatment for grocer’s itch is sulphur, or better, an alcoholic solution of beta naphthol. As very little unrefined sugar is now sold the practical danger to the people is small, but children, who are too prone to call for sugar, might well be treated to a sight of some infected brown sugar under the microscope.

### MICROSCOPICAL NEWS.

**Adulterated Bread.**—In the famine-stricken regions of Russia the government has distributed some bread which the contractors had badly adulterated. A specimen was sent from—not the worst, but the best—bread so distributed to England, where a microscopical examination revealed fragments of plant leaves, husks and small seeds resembling rape, as well as mineral particles. In the rye bread as much as 10 per cent. was found to consist of indigestible leaves and woody fibre. Coarse particles could be seen with an ordinary lens. Six per cent. was found to consist of mineral matter including silica and sand.

A Russian, speaking of some of the worst samples, says : “ I found

in many cases that this so-called bread contained no rye-flour whatever, but was composed of ravega (wild arrock), potato, chaff, and leaves. Within  $1\frac{1}{3}$  miles of my house are more than 130 cases of typhus."

**Milk.**—At the International Hahnemann Association, Dr. Rushmore declared that microscopic examination of milk has shown that of the Ayrshire cow to be the best.

**How Lenses are Made.**—In the city of Munich is one of the most celebrated lens manufactories in the world, its wonderful products being in demand in all the countries of Europe. The perfection characterizing these lenses is due to the unvarying precision and faultlessness of work applied to every object produced before it is permitted to leave the Steinheil establishment. The lenses, after being roughed out in cast-iron molds by hand, are ground fine by means of emery powder and water in glass moulds, each workman being provided with a glass model of the surface to be imparted to the lens (such surface in all cases being spherical), and each is tested to see that it has received its proper curvature by means of a so-called spherometer. The different operations of grinding, finishing, polishing, centering, etc., are all performed by separate workmen, who are practiced in one of these particular branches only, and further, the grinding and polishing rooms are carefully separated from one another, as also the machinery employed, by which precautions the presence of emery powder where it is not wanted is prevented, and the scratches and the injury to a lens which result therefrom are avoided. The polishing of the lenses is by means of rouge, this being done in moulds made of pitch, instead of on cloth (as in many other manufactories of this kind), thus enabling a more perfectly spherical surface to be obtained than otherwise would be possible. A commodious testing apparatus is provided, of some sixteen by seven meters dimensions, furnished with the finest appliances, and here all the lenses, apparatus, etc., produced at the establishment, are accurately tested, except the larger sizes of telescopes, which are subjected to the same ordeal in a passage on the ground floor.

---

### CORRESPONDENCE.

---

**White's Objects** "are marvellous for the price. You deserve thanks of all students of botany for introducing them."—*G. H. Hicks, Owasso, Mich.*

---

### NEW PUBLICATIONS.

---

*Surgical Treatment of Pyloric Stenosis.* N. Senn, M. D.  
Chicago, Ill., 56 pp.

Dr. Senn is in charge of St. Joseph's Hospital, Chicago, where he has ample opportunity for the study of this disease. This is an address delivered before the N. Y. State Medical Association, Oct. 28, 1891.

*Vick's Floral Guide,* Rochester, N. Y.

A nicely illustrated catalogue to select seeds from—flowers or vegetables.

*A Vegetable Plate.* By Robert H. M. Dawburn, M. D. New York, 20 pp.

Potato is used as a plate in intestinal anastomosis.

*Tobacco, Insanity, and Nervousness.* By Dr. L. Bremer. St. Louis, Mo., pp. 16.

The boy who smokes at 7 will drink at 14, take morphine at 21, and cocaine at 30. When one has made a firm resolution to quit, a combination of bromides, Indian hemp, and bitter tonics will tide the victim over the uneasiness of tobacco hunger.

*Annual Report of the Postmaster-General.* By John Wanamaker, Washington, 180 pp.

The large and interesting illustrations make this an unusual "pub. doc." A copy will, doubtless, be sent you free on application to the Department.

*Stricture of the Rectum.* By Chas. B. Kelsey, M. D., New York City, 48 pp.

An unusually neat and attractive presentation of a subject on which very little is known.

*Essentials of Medical Physics.* By Fred. J. Brockway, M. D. Philadelphia, W. B. Saunders, 12mo., pp. 330; cuts, 155. Price \$1.00.

This is question compend No. 22, and makes an excellent syllabus on physics. The five chapters are on (1) properties of matter, (2) heat, (3) light, (4) sound, (5) magnetism and electricity.

Under light, mirrors and lenses, optical instruments and photography are included. One page is devoted to microscopes, simply to explain the principles involved. The eight pages on photography contain an excellent exposition of the subject.

The general appearance, typography, and profuse illustration of this number are the same as of No. 20, on bacteriology, which we noticed last month. The index is easily found, and is not obscured by voluminous advertisements at the end of the volume. The price is very reasonable.

*Plant Organization.* By R. Halsted Ward, M. D. Ginn & Company, Boston.

This book is a guide to the study of plants. It consists of a synoptical review of the general structure and morphology of plants, clearly drawn out according to biological principles, fully illustrated, and accompanied by a set of blanks for writing exercises by pupils. It also provides some easy microscopical work. Though requiring a very thorough study and exact understanding of the plants which may be selected for study, the work is so systematized and simplified as to be adapted to the use of beginners, in connection with personal instruction or with any text-book of botany however elementary, and either with or without the employment of technical botanical terms. The work, which is designed for private students or for classes in Academies, Seminaries, High Schools, etc., is now issued in a second and revised edition, after having proved its value.

*Public Ledger Almanac,* Geo. W. Childs, contains very useful statistics and memoranda.



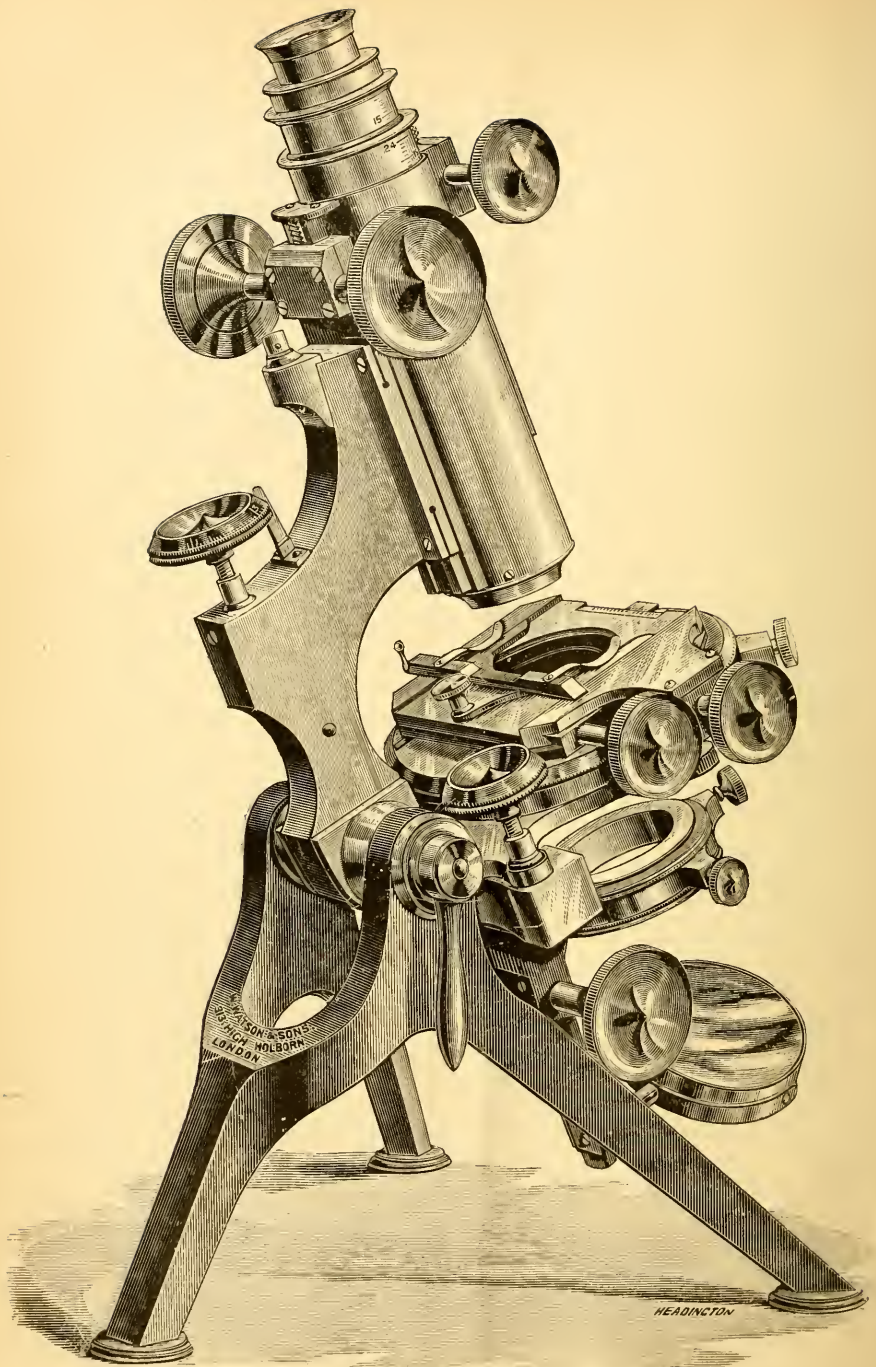

DR. HENRI VAN HEURCK'S MICROSCOPE FOR HIGH-POWER WORK AND PHOTO-MICROGRAPHY.

# THE AMERICAN

## MONTHLY

# MICROSCOPICAL JOURNAL.

VOL. XIII.

MARCH, 1892.

No. 3.

### CONTENTS.

<p>Use of the Microscope in Pharmacy. —WHELPLEY - - - - - 49</p> <p>Adulteration of Lycopodium - - - 50</p> <p>A Beautiful Rhizopod.—SMILEY.— (Illustrated) - - - - - 51</p> <p>Biological Examination of Potable Water.—RAFTER.—(Illustrated) 55</p> <p>Radiolaria: Their Life-History and Their Classification. — CARTER. 63</p> <p>EDITORIAL.—Dr. Ray Lankester. Prof. H. L. Tolman - - - - - 65</p> <p>MICROSCOPICAL APPARATUS.—Ed- inger's Drawing Apparatus for Low Magnification (Illustrated). Durkee's Electric Illuminator (Illustrated). Photomicrographs of Diatoms. Photomicrography. Continental Apparatus in Eng- land - - - - - 65</p> <p>MICROSCOPICAL MANIPULATION.— Cutting Glass Tubes, Bottles, etc. Cement. Mounting Stentors and Spirostomum by the use of Hy- droxylamine - - - - - 67</p> <p>DETECTING CRIME WITH THE MI- CROSCOPE.—Examining Garments. 68</p>	<p>BIOLOGICAL NOTES.—Growth of Seeds. Digging Powers of the Newly-Discovered Mole. The Fresh-Water Sponges. The Cot- ton Crop. Crustaceous Parasites of Fishes - - - - - 70</p> <p>DIATOMS.—Life-History—their clas- sification - - - - - 71</p> <p>BACTERIOLOGY.—The Influenza Bac- illus. Useful Work - - - - - 71</p> <p>RECREATIVE MICROSCOPY.—Soirées. 72</p> <p>MEDICAL MICROSCOPY.—The Klebs- Loeffler Bacillus and Associated Forms. The Water Supply of Washington - - - - - 73</p> <p>MICROSCOPICAL NEWS.—Microscopy at the Columbian Exposition. A Bargain List. Dr. Chas. P. Pen- gra - - - - - 74</p> <p>CORRESPONDENCE - - - - - 74</p> <p>MICROSCOPICAL SOCIETIES.—San Francisco. Calcutta. New York. 74</p> <p>NEW PUBLICATIONS.—Carpenter. Fowler. Rolfe. Nicholson - - - 76</p> <p>WANT, SALE, AND EXCHANGE NO- TICES - - - - - 80</p>
-------------------------------------------------------------------------------------------------------------------------------------------------------------------------------------------------------------------------------------------------------------------------------------------------------------------------------------------------------------------------------------------------------------------------------------------------------------------------------------------------------------------------------------------------------------------------------------------------------------------------------------------------------------------------------------------------------------------------------------------------------------------------------------------------------------------------------------------------------------------------------------------------------------------------------------------------------------	--------------------------------------------------------------------------------------------------------------------------------------------------------------------------------------------------------------------------------------------------------------------------------------------------------------------------------------------------------------------------------------------------------------------------------------------------------------------------------------------------------------------------------------------------------------------------------------------------------------------------------------------------------------------------------------------------------------------------------------------------------------------------------------------------------------------------------------------------------------------------------------------------------------------------

### Use of the Microscope in Pharmacy.

By H. M. WHELPLEY, M. D.,

ST. LOUIS, MO.

[From a paper read at the A. S. M., 1891.]

1. Use of the Simple Microscope.—*a.* The student of pharmacy learns early in his college days that the simple microscope is almost indispensable while pursuing the study of botany. The importance of botany is recognized in every pharmaceutical college, because its principles rest at the foundation of the knowledge of vegetable drugs. The proportion of animal drugs used to-day is very small, so that the study of zoölogy in colleges of pharmacy is usually overlooked.

*b.* In order to study drugs, the pharmacist classifies them according to their organileptic and other characteristics. This system is not without fault, but it is nearest perfect of any that has been devised, and it has been adopted by all works on materia medica which are intended solely for the use of pharmacists. While many of the physical characteristics of the vegetable drugs can be studied with the unaided eye,

there remains a large proportion which requires the use of the microscope. Medicinal leaves, closely resembling each other, can be distinguished by a microscopical examination of the hairs found upon their surface; as an example, we take mullein leaves, which are thickly covered with beautiful stellate hairs, aconite leaves are sometimes adulterated with mullein leaves, but the stellate hairs enables the simple microscope to show the difference, even after the leaves have been pressed and otherwise mutilated. The hairs found upon aconite leaves are less numerous than the mullein hairs, and further distinguished from them by not branching. The fissures, ridges, warts, hairs, scars, etc., found on barks, leaves, rhizoms, woods, and other parts of the plants employed in medicine, are physical characteristics which can be distinguished by means of the simple microscope, and aid the pharmacist in recognizing vegetable drugs.

c. The simple microscope again comes into play for the pharmacists, while examining many of the medicinal preparations, in order to determine their quality or prove their identity. In some instances, the United States Pharmacopœia prescribes that the simple microscope should be used in testing the quality of preparations; as an example, we have the ordinary mercury ointment, which is a mixture of metallic mercury with animal fats. The Pharmacopœia states that this should be mixed until the globules of metallic mercury cannot be distinguished by means of a microscope magnifying ten diameters.

d. The simple microscope may also be made serviceable while testing the quality of some of the utensils used in a pharmacy. As a case comes in point, we cite the examination of sieves to see that they have the proper number of meshes to the linear inch. Some of the finer sieves would require the use of the compound microscope, while the simple microscope will answer in the examination of the coarser sieves, which are more commonly used.

e. The simple microscope is a convenience when attempting to make out a prescription number upon soiled labels, which pharmacists receive when prescriptions are to be refilled. It is also convenient in the examination of bills which are suspected of being counterfeit. It can be used when it becomes necessary to remove a sliver of wood from the flesh, and there are a thousand and one instances where the pharmacists can conveniently make use of the simple microscope. Some of the insects which infest drugs are appropriately studied by means of the simple microscope. Customers may also be interested in the instrument, and its use is then turned to a commercial advantage by drawing trade.

[*To be continued.*]

**Adulteration of Lycopodium.**—Talc, gypsum, resin, dextrin, starch, sulphur, pine-pollen, sand, tumeric, and various sporules have been used. Dr. Whelpley recently examined and found three specimens to be pure with the exception of accidental traces of vegetable tissue. He says: The drug is best examined with a power of about one hundred diameters. The specimens examined by reflected light show better than those in liquid. However, it is advisable to use both methods. Macerate for some weeks in glycerin, and mount in glycerogum for examination by transmitted light.



## A Beautiful Rhizopod.

By CHAS. W. SMILEY,

WASHINGTON, D. C.

At the lowest point in the animal kingdom stand the protozoa. Of these there are four classes: I, the Monera (without any organs); II, the Rhizopoda (having a nucleus and outer layer of sarcode); III, the Gregarinida (an ovate, animal parasite); and IV, the Infusoria (having a definite shape and usually one or more mouths), holding the highest place in the quartette.

The Rhizopods are rarely visible to the naked eye, but they abound everywhere if there is moisture or dampness—in ponds, in lakes, in swamps, in sea, in ocean. Some grow in salt water and some in fresh. Leidy has written only upon the fresh-water forms. Ponds and ditches may be skimmed for specimens with a small tin dipper and the superficial ooze transferred to a bottle to await examination. Often specimens may be scraped up from wet ground with the blade of a knife, their presence being betrayed by the green algal material which is plainly visible. Their pursuit is feasible at nearly all times of the year, even in winter, if vegetation is not completely covered by ice and snow.

At this time of year our readers may well begin the collection of specimens, preserving them as described by Leidy and other authorities. The Rhizopods are classified by Hitchcock (Riverside Natural History) in (1) Lobosa, (2) Radiolaria, (3) Heliozoa, (4) Reticularia.

Of the Heliozoa, or sun animalcules, he says that they are very beautiful, being mostly spherical and floating forms. A few are attached by long pedestals. They put out delicate rays in all directions from the centre, often exceeding the diameter of the body in length.

The most common of the Heliozoa is *Actinophrys sol*, which occurs in pools of standing water almost everywhere among floating plants. Under a low power of the microscope it is a colorless, spherical body, 4-100th to 12-100th mm. in diameter. The great number of delicate spines can be seen projecting from the body to 3 or 4 times its diameter. But the most beautiful form of this order is *Clathrulina elegans*. Its capsules become yellow with age, presenting a rich golden appearance, and it is often found in ponds and ditches.

If our readers will search for these forms and report their finds, we shall be glad to publish the list in May or June. By means of the plates in Leidy's Fresh-Water Rhizopods they may be identified by any careful observer. Our attention is drawn at this time to *Clathrulina* by the fact that it has recently been discovered, for the first time in Asia, by Mr. Simmons, our esteemed correspondent, the secretary of the Calcutta Microscopical Society. On the occasion of his making known his find, he presented not only specimens but some elegant illustrations, which Mr. Robert W. Smiley has redrawn for presentation with this paper.

At the December meeting in Calcutta, J. Wood-Mason gave a *résumé* from German and Russian authorities of our knowledge of *Clathrulina elegans*, which we reproduce below, much of it being new to English-speaking people:

“This wonderful and delicate heliozoan presents itself under a low ( $\frac{1}{2}$ -inch) power of the microscope as a simple drumstick-shaped body consisting of a long and thin cylindrical stalk, which at one end is sud-

denly expanded into a ball, while at the other it is attached to a bit of water-weed, or other foreign object, as, for instance, the shell of another individual of its own kind (Fig. 1).

“Examined under a higher ( $\frac{1}{4}$ -inch) power, the stalk is seen to be an empty tube, as is proved by its doubly-contoured margins in optic longitudinal section, divided or frayed out at its base into two or more root-like processes for attachment, whilst the ball becomes resolved into a regular or slightly elongated hollow sphere, perforated on all sides by large holes separated from one another by bars or bridges of the substance forming its wall, much in fact like a piece of perforated zinc, but with these differences, that while in perforated zinc the holes are invariably of the same size and shape, and are invariably separated by bars of equal width throughout, in the shell of *Clathrulina* they often vary in size from specimen to specimen, and are hence separated from one another by bars of varying width—these being sometimes narrow and rod-like, and sometimes wide and plate-like—and they also differ in shape, varying from round or oval to polygonal with the angles of the polygon rounded off. The sphere and the stalk, which consist from first to last of a single continuous piece, form a skeleton; the sphere serving as a supporting and protective envelope or shell for the body of a delicate unicellular animal allied to the well-known sun animalcule (*Actinophrys sol*), and the stalk furnishing a firm though flexible support for the shell and its occupant. The skeleton, which is siliceous, is colorless in young specimens, and sometimes remains so throughout life, but more commonly assumes with age a yellowish or brownish color, which in full grown examples is so deep as greatly to interfere with the observation of the structure of the body of the heliozoan. The external surface of the shell is marked by a net-work of grooves, which are sometimes so faintly indicated as to be scarcely traceable, but at others are very deep, in which latter case their margins are so prominent as in optic transverse section of the shell to present the appearance of spines.

“The stalk also varies greatly in length, ranging from twice to six times the diameter of the shell. Of recorded measurements the maxima are: Diameter of shell, .072 mm.; diameter of stalk, .003 mm.; length of stalk, 3.000 mm.

“The protoplasmic body of the animal may in young specimens completely fill or even envelop the shell; but in fully developed and active individuals it does not nearly do so, a wide space intervening between its outer surface and the inner surface of the shell. It exhibits no differentiation into exoplasm and endoplasm. In outline it is irregular, its surface being drawn out into lobes here and there at the origin of numerous radiating pseudopodia, in which respect it offers a marked contrast to *Actinophrys*, whose contours are regular. Two kinds of vacuoles are present in the granular protoplasm of which the animal's body is composed: vacuoles containing food, and vacuoles containing only fluid. The latter form hemispherical protuberances of the surface, and are at all events partially contractile. There is besides a central nucleus, which can only with difficulty be made out in the living animal, in consequence partly of the more or less dark color of the shell. Pseudopodia radiate from all parts of the surface through the holes in the latticed shell. They are richly granular threads of extraordinary

tenuity which branch and anastomose with tolerable frequency, but are not stiffened by an axial fibre, as in other Heliozoa. Assimilation of food particles taken up by the pseudopodia as a rule takes place in the interior of the animal; but when, as sometimes happens, the food particles are too large to pass through the holes in the shell, digestion is carried on outside the body, and is performed by the pseudopodia, which are rendered broader by an afflux of protoplasm to them from the main mass, and invest the foreign body with a thin coating.

"*Clathrulina* multiplies by several methods. The simplest of these is the simple fission, in which the protoplasmic body divides into two parts, which for sometime after complete separation remain in the shell and continue to emit pseudopodia, but sooner or later withdraw their pseudopodia, form themselves into a ball, force their way through

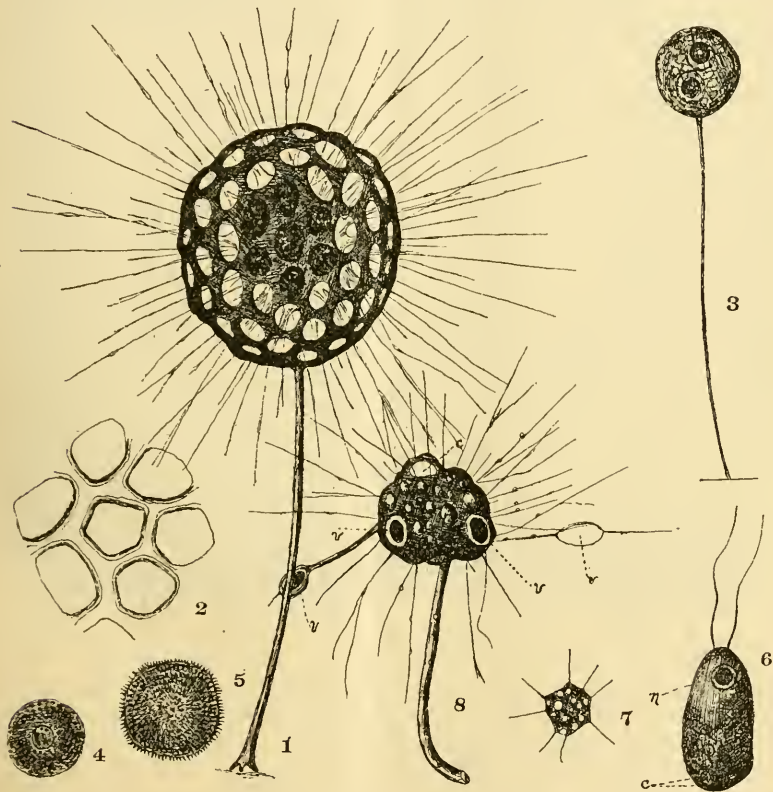

## EXPLANATION OF PLATE.

FIG. 1.—*Clathrulina Elegans*, x 350.

FIG. 2.—Enlargement (600 dia.) to show grooving of the outer surface of the latticed shell.

FIG. 3.—An individual in which the products of the simple fission of the protoplasmic body have become encysted.

FIG. 4.—A product of fission with pseudopodia withdrawn, globular, preparatory to encystment (x 320).

FIG. 5.—A cyst covered with minute siliceous spinelets (x 600).

FIG. 6.—A zoospore with 2 flagella, nucleus (*n*) and 2 contractile vesicles (*c*).

FIG. 7.—A flagella which has lost its shape and become an amebula.

FIG. 8.—A young specimen which has a stalk (*s*) but no shell yet, food vacuoles (*v v*) and contractile vesicle (*c*).

the holes in the shell to the exterior, and without further ado there settle down, put forth pseudopodia, form a stalk and fix themselves, and finally silicify the protoplasmic foundations of their skeleton—in fact, become directly transformed into perfect forms.

“Another method consists in the simple or the multiple fission of the protoplasmic body into a larger or smaller number of parts, which, instead of leaving the shell at once and settling down as naked and active bodies called amœbulæ, as in the preceding method, become encysted, each surrounding itself with a case, the outer surface of which is beset with fine siliceous spines. After a long rest, which probably lasts all the winter, there is developed from each cyst one free-swimming zoöspore, or flagellula, which in its anterior and somewhat pointed homogeneous end contains a nucleus, and in its posterior granular end two or more contractile vacuoles, and is furnished with a pair of long, whip-like cilia, or flagella, for locomotion. The description of the transformation of these flagellulæ into *Clathralina* will be given below.

“In a third method, the protoplasmic body divides by multiple fission into three—two smaller and equal and one larger equal to the other two together—or rather probably into two, one of which again divides into two, while the other does not, or at least has not been observed to do so. The fate of the latter is not certainly known, but it may with confidence be inferred that it also, in turn, divides into two, which quit the shell as flagellulæ. However this may be the products of the division of the former half quit the shell at or about the same time by forcing their way through the holes in its walls, and as soon as they are free form *flagellulæ* like those already described under the second method. After swimming about for a short time with a slow, rotatory movement, the young germ places itself upright upon the object to which it will eventually attach its stalk, and assumes a globular form, revolving the while about its own axis without change of position. With the cessation of movement, pseudopodia are quickly developed on all sides, and the body takes the form of an amœbula similar to that with which development began in the first method. The stalk arises as a process of the body substance, in which at an early stage granule currents are plainly to be made out, and it is hence primitively a protoplasmic structure. Later on, the skeleton of the definitive stalk is developed upon this protoplasmic foundation, in all probability by the impregnation with silica of a thin layer of exoplasm and by the subsequent withdrawal into the body substance of the fluid protoplasmic core. However this may be, in the fully developed animal the stalk is also an empty tube, continuous with the latticed shell. The development of the latticed shell has not been fully followed, but it appears probable that it, like the skeleton of the stalk, is also pre-formed in protoplasm, which subsequently becomes hardened by deposit of siliceous salts upon, or within, its substance. Thus, in the two later methods of multiplication, we have a distinct metamorphosis, the young differing from the adult in form and habit; and of the three methods, those that are accompanied by a metamorphosis are the most important to the species as securing its dispersal.”

## Biological Examination of Potable Water.

By GEO. W. RAFTER,

ROCHESTER, N. Y.

[From Proceedings of the Rochester Academy of Science.]

The biological examination of water requires the determination of all the minute life occurring in various classes of water, and is divided into two distinct investigations, the microscopical and the bacterial. The microscopical examination includes the determination of all those forms of life which are easily studied in all their phases by use of the microscope. These forms include among plants, algæ, larger fungi, etc., and among animals, sponges, infusoria, rotifers, the smaller crustacea, and others.

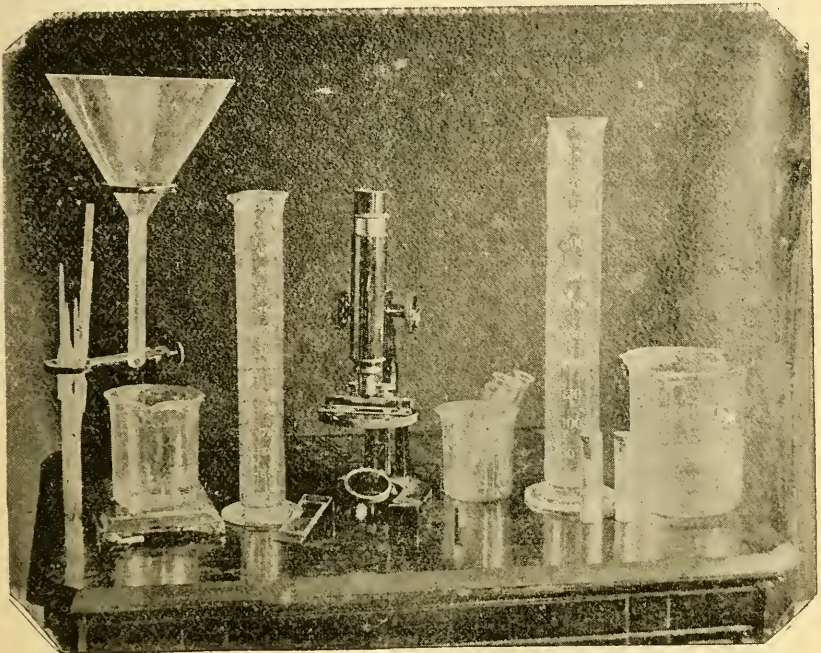

COMPLETE APPARATUS FOR BIOLOGICAL EXAMINATION OF WATER.

The bacterial examination requires cultures as an integral part of the process, and only incidentally makes use of the microscope, inasmuch as examinations and partial identifications may be made from plate and tube cultures without the use of the microscope at all.

The methods of making bacterial examinations have been fairly worked out for several years, but until recently no definite method of making the accurate determination of the number of the so-called microscopic forms has been known.

The present paper includes the microscopical examination only, and the methods here indicated have no reference to the bacteria.

Something over three years ago the Microscopical Section of this Academy began a systematic study of the forms of minute life present in the Hemlock Lake water supply of this city. The method of

obtaining specimens was to fasten a bag of plain muslin to a kitchen faucet and allow the water to flow through until the pores of the cloth were partially clogged with the arrested organisms; the bag was then removed from the faucet, turned wrong side out and the organisms washed off into a beaker or tumbler. Subsidence took place in a few minutes, after which specimens for examination were selected by dipping with a small tube or medicine dropper from different depths. This was the only method used during the two years that the Microscopical Section was engaged upon this special study, and indeed was as practical a method as any that had up to that time been devised.

McDonald, in his water analysis, had suggested several years before the use of a watch-glass suspended in a tall glass of comparatively small diameter, for instance a 500 c.c. measure glass. His method of procedure was essentially to fill such a measure glass with

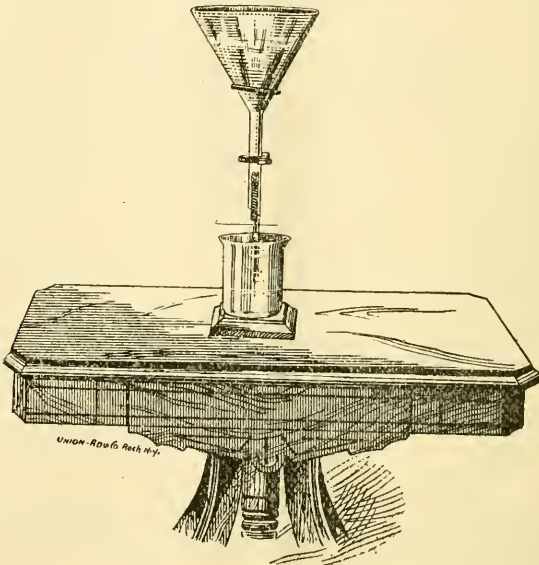

FUNNEL, WITH PLUG AND SAND IN PLACE.

the water to be examined, and to suspend in it at the bottom a watch-glass, after which the whole, lightly covered, was set aside for perhaps 24 hours. At the end of this time the water was siphoned off with a piece of India-rubber tubing so as to leave only a thin stratum of liquid in the watch-glass at the bottom. The watch-glass was now raised and samples selected with a pipette for examination on a glass slide, or the watch-glass itself placed upon the stage of the microscope for direct examination. This method was, at the best, crude and unsatisfactory, and as it could give only qualitative results, it is doubtful if with any operator it has ever passed much beyond the experimental stage. The method used by the Microscopical Section was somewhat more simple, and gave all the information that could be obtained by the use of the more elaborate method of McDonald.

Mr. Hogg in the tenth edition of his work on the microscope has added a chapter on the microscopical examination of potable water, but without advancing any methods other than those previously announced by McDonald. Likewise Tiemann and Gärtner, the recent German authorities, have added nothing to our knowledge of this part of the subject.

The matter of qualitative examination of the micro-organisms in potable water remained in about the state indicated by the foregoing until a little less than a year ago, when Prof. Wm. T. Sedgwick, of the Massachusetts Institute of Technology, worked out a method for making the quantitative determination as well.\* This consists, first, in the concentration of the organisms from a large amount of water into so little water that they may be readily examined under the conditions imposed by microscopical technique; and, second, of an actual enumeration of all the organisms present in a given quantity of water. The first point is attained by filtration through a short column of fine sand in the lower end of the stem of a small funnel, the sand being supported upon some material which will allow the water to pass freely and still retain the sand in position. After placing the sand, a measured quantity of water is poured into the funnel and allowed to filter through. The sand retains nearly all the organisms which were originally distributed through the water. The enumeration is secured, according to Prof. Sedgwick, by removing the supporting plug and washing the sand and contained organisms into a cell, 50 x 20 millimetres in area, and about 2 to 2½ millimetres in depth. The glass bottom of this cell is ruled into square millimetres, and by passing a number of these squares through the field of a microscope their contents are counted and from the counts so made the whole number present in the cell is obtained. This method while far in advance of that of McDonald is still somewhat unsatisfactory in this, that the sand and organisms are both allowed to pass into the cell together, and inasmuch as the finest grains of sand are much larger than many of the organisms, it follows that the enumeration, however carefully made, is only a rough approximation to the number actually present, and usually falls short of the number actually present.

The method of Prof. Sedgwick came to my notice about nine months ago, and after examination it appeared quite evident that considerable additional refinement was possible, and to this I addressed myself with the result of finally perfecting the technique in the manner which I now briefly lay before you.

In the method, as I now use it, the sand is supported upon a plug of wire cloth placed at the lower end of the funnel stem, as shown on page 56. After placing the plug the sand is run into the funnel, lightly pressed to place with a glass rod, and from 20 to 40 c.c. of freshly-filtered water allowed to run through in order to insure thorough settling of the sand before actually beginning the filtration. The amount of water to be filtered is gauged by the number of organisms which it contains, as ascertained by preliminary inspection. Generally, however, as large a quantity should be used as can be conveniently filtered without clogging the sand so much as to render the completion of the

\* See paper on Recent Progress in Biological Water Analysis in Transactions of New England Water-Works Association, September, 1889.

process too prolonged, and for ordinary samples I have fixed upon 500 c.c. as the proper amount. In the case of very pure waters a larger amount will be desirable, and for such 1000 c.c. may be adopted as a convenient unit.

Experience indicates that however carefully the sand may be placed, the filtration at the beginning will not be as complete as further on, and in order to insure the certain removal of all the smaller organisms the first 100 to 150 c.c. of the filtrate is returned to the funnel and passed through the sand the second time. The funnel is allowed to stand until the completion of the filtration, when it is found on examination of the filtrate that nearly every organism has been removed and we have the result that the organisms originally contained in the 500

*Plan*

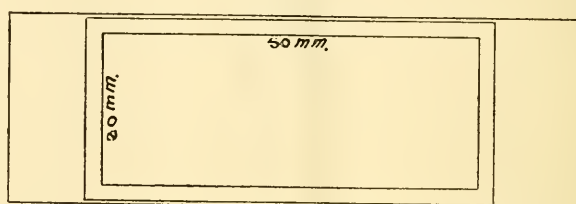

*Section*

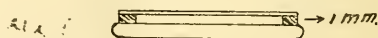

*Fig. 1. Plan and Section of cell with cover glass.*

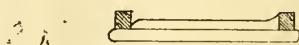

*Fig. 2. Section of open cell showing curve of surface of fluid due to capillary attraction at sides.*

c.c. of water are all in the sand at lower end of funnel stem. The plug of wire cloth is now removed, and the sand and contained organisms washed with 5 c.c. of freshly-filtered water, run from a 5 c.c. pipette into a 5 or 6-inch test tube. The test tube is slightly shaken in order to wash all the organisms clear from the sand. The sand by reason of greater specific gravity sinks quickly to the bottom, leaving the organisms distributed through the water. At the instant of the completion of the settling of the sand the supernatant water is turned into another smaller test tube, leaving the clean sand at the bottom of the first tube. We now have the organisms from 500 c.c. of water concentrated into 5 c.c. in the second tube, from which after slight stirring, to insure uniform distribution, 1 c.c. is taken with a 1 c.c.



pipette and transferred to a cell 50 by 20 millimetre area, and exactly 1 millimetre in depth. Such a cell of course contains 1000 cubic millimetres, or 1 c.c. The top of the metal cell is ground perfectly smooth and with a little practice one can float a thick cover-glass to place without losing a drop.

The next step is the enumeration. This is accomplished by transferring the cell to the stage of a microscope, the eye-piece of which is fitted with a micrometer so ruled as to cover, with a given objective and fixed tube length, a square millimetre on the stage. The microscope itself is fitted with a mechanical stage with millimetre movement in both directions; and for this purpose I have made certain simple additions to the new mechanical stage of the Bausch and Lomb Optical Company, by means of which the desired result is obtained at slight expense. The count is made by beginning at one corner of the cell and going systematically over the area in accordance with such a formula as will insure the count of squares selected from every part of the slide. The number of squares actually counted will depend upon the degree of accuracy which it is desired to attain. It is obviously impossible to count the 1000 squares composing the entire area of the slide, and the practical question arises as to just what multiple of 1000 shall be used to secure a correct average. This can only be determined by trial and comparison upon a number of samples. In any case, not less than 20 squares should be counted, and if time will possibly permit I should prefer to always count at least 50.

In order to illustrate the matter, I have prepared a table which represents the area of the cell divided into 1000 squares. Brief inspection of this table will show the difficulty of obtaining true averages when only 20 squares are counted, and exhibits clearly the value of counting the larger number if one cares for true averages. (See Table, page 60.)

I consider the precise millimetre movement of the mechanical stage a matter of considerable importance, and indeed insist upon it as an integral part of the method. Without it the tendency will be to sometimes select squares for counting which are contiguous, while at other times one will pass over squares containing few or no organisms in a search for more prolific ones, making, in either case, an error in the final result. By use of the mechanical stage with a definite formula for passing over the slide, personal errors of this sort are eliminated, leaving only those which are due to irregularity of distribution of the organisms in the water, and by always stirring thoroughly before taking the portion for examination with 1 c.c. pipette this error may also be reduced to a small degree, provided as many as 50 squares are counted as the basis of the final average. Additional uniformity of distribution of organisms in the cell may also be obtained by stirring gently in the cell itself with the pointed end of the pipette, before floating the cover-glass to place, but the precaution should always be taken in these stirring operations to proceed gently in order to guard against breaking up unnecessarily the particles of amorphous organic matter which are nearly always present in any sample of water in which algal growths and decay are taking place.

The definite estimation of the amorphous organic matter is a thing of some difficulty, and in my own use of this method I have formed a

Table No. 1. Enlarged outline plan of counting cell 20 mm by 50 mm divided into squares each representing one square millimetre.

1	2	3	4	5	6	7	8	9	10	11	12	13	14	15	16	17	18	19	20	21	22	23	24	25	26	27	28	29	30	31	32	33	34	35	36	37	38	39	40	41	42	43	44	45	46	47	48	49	50
51	52	53	54	55	56	57	58	59	60	61	62	63	64	65	66	67	68	69	70	71	72	73	74	75	76	77	78	79	80	81	82	83	84	85	86	87	88	89	90	91	92	93	94	95	96	97	98	99	100
101	102	103	104	105	106	107	108	109	110	111	112	113	114	115	116	117	118	119	120	121	122	123	124	125	126	127	128	129	130	131	132	133	134	135	136	137	138	139	140	141	142	143	144	145	146	147	148	149	150
151	152	153	154	155	156	157	158	159	160	161	162	163	164	165	166	167	168	169	170	171	172	173	174	175	176	177	178	179	180	181	182	183	184	185	186	187	188	189	190	191	192	193	194	195	196	197	198	199	200
201	202	203	204	205	206	207	208	209	210	211	212	213	214	215	216	217	218	219	220	221	222	223	224	225	226	227	228	229	230	231	232	233	234	235	236	237	238	239	240	241	242	243	244	245	246	247	248	249	250
251	252	253	254	255	256	257	258	259	260	261	262	263	264	265	266	267	268	269	270	271	272	273	274	275	276	277	278	279	280	281	282	283	284	285	286	287	288	289	290	291	292	293	294	295	296	297	298	299	300
301	302	303	304	305	306	307	308	309	310	311	312	313	314	315	316	317	318	319	320	321	322	323	324	325	326	327	328	329	330	331	332	333	334	335	336	337	338	339	340	341	342	343	344	345	346	347	348	349	350
351	352	353	354	355	356	357	358	359	360	361	362	363	364	365	366	367	368	369	370	371	372	373	374	375	376	377	378	379	380	381	382	383	384	385	386	387	388	389	390	391	392	393	394	395	396	397	398	399	400
401	402	403	404	405	406	407	408	409	410	411	412	413	414	415	416	417	418	419	420	421	422	423	424	425	426	427	428	429	430	431	432	433	434	435	436	437	438	439	440	441	442	443	444	445	446	447	448	449	450
451	452	453	454	455	456	457	458	459	460	461	462	463	464	465	466	467	468	469	470	471	472	473	474	475	476	477	478	479	480	481	482	483	484	485	486	487	488	489	490	491	492	493	494	495	496	497	498	499	500
501	502	503	504	505	506	507	508	509	510	511	512	513	514	515	516	517	518	519	520	521	522	523	524	525	526	527	528	529	530	531	532	533	534	535	536	537	538	539	540	541	542	543	544	545	546	547	548	549	550
551	552	553	554	555	556	557	558	559	560	561	562	563	564	565	566	567	568	569	570	571	572	573	574	575	576	577	578	579	580	581	582	583	584	585	586	587	588	589	590	591	592	593	594	595	596	597	598	599	600
601	602	603	604	605	606	607	608	609	610	611	612	613	614	615	616	617	618	619	620	621	622	623	624	625	626	627	628	629	630	631	632	633	634	635	636	637	638	639	640	641	642	643	644	645	646	647	648	649	650
651	652	653	654	655	656	657	658	659	660	661	662	663	664	665	666	667	668	669	670	671	672	673	674	675	676	677	678	679	680	681	682	683	684	685	686	687	688	689	690	691	692	693	694	695	696	697	698	699	700
701	702	703	704	705	706	707	708	709	710	711	712	713	714	715	716	717	718	719	720	721	722	723	724	725	726	727	728	729	730	731	732	733	734	735	736	737	738	739	740	741	742	743	744	745	746	747	748	749	750
751	752	753	754	755	756	757	758	759	760	761	762	763	764	765	766	767	768	769	770	771	772	773	774	775	776	777	778	779	780	781	782	783	784	785	786	787	788	789	790	791	792	793	794	795	796	797	798	799	800
801	802	803	804	805	806	807	808	809	810	811	812	813	814	815	816	817	818	819	820	821	822	823	824	825	826	827	828	829	830	831	832	833	834	835	836	837	838	839	840	841	842	843	844	845	846	847	848	849	850
851	852	853	854	855	856	857	858	859	860	861	862	863	864	865	866	867	868	869	870	871	872	873	874	875	876	877	878	879	880	881	882	883	884	885	886	887	888	889	890	891	892	893	894	895	896	897	898	899	900
901	902	903	904	905	906	907	908	909	910	911	912	913	914	915	916	917	918	919	920	921	922	923	924	925	926	927	928	929	930	931	932	933	934	935	936	937	938	939	940	941	942	943	944	945	946	947	948	949	950
951	952	953	954	955	956	957	958	959	960	961	962	963	964	965	966	967	968	969	970	971	972	973	974	975	976	977	978	979	980	981	982	983	984	985	986	987	988	989	990	991	992	993	994	995	996	997	998	999	1000

sort of mental standard as to the unit of area covered by one mass of the amorphous matter. Mr. Geo. C. Whipple, who has assisted me in some experimental work for the Boston Water Works, has suggested that this unit be made definite for all persons by taking it a fixed number of square microns, and for this purpose 20 microns seems to be the desirable unit. By careful comparison with a stage micrometer for a few times, this unit can be firmly fixed in mind and an estimate of the amount of amorphous matter made with considerable precision.

The advantage of a cell of such depth as to just contain the quantity taken for examination is illustrated by figure 2, which represents the *open* cell and shows the meniscus form taken by the liquid, by reason of capillary attraction at the sides. This curvature is so considerable as to render a count in the squares near the edges of the cell impracticable, for optical reasons, which every user of the microscope will readily understand. With the covered cell, on the contrary, the count may be made up to the sides as easily and with as much certainty as in the middle.

The placing of the cover-glass is easily accomplished, although the careful observance of certain details are essential to uniform success. Thus the cover-glass should be perfectly clean, and just before placing should be moistened. The operation of putting it to place consists in laying one end, held in a horizontal position, in contact with the ground upper surface of the metallic portion of the cell, and, while keeping it in close contact at all points, gradually sliding it forward until the whole cell is covered. In this connection it may be noted that cleanliness is quite essential in all these operations, and the hints given by McDonald cover the case.

In the original cell, as designed by Prof. Sedgwick, the division into squares for the purpose of obtaining the relation of organisms to area was arrived at by ruling square millimetres upon the upper surface of the glass slide on which the cell is based. This, however, gives a unit square only for the bottom of the cell, and for all organisms at the top of the liquid no unit of area is obtained, inasmuch as the considerable change of focus required in order to see them at all renders it impossible to distinguish the ruled lines and such floating objects at the same time. With the eye-piece micrometer, however, this difficulty is removed, and the unit square is clearly in the field of vision without reference to the plane in the cell upon which the objective is focussed.

The working objective for these counts may be either a two-thirds or one-half inch, and for identification of minute unknown forms a one-fourth or one-fifth water immersion capable of working through a thick cover-glass and cell one millimetre in depth would be useful. I have, however, no experience with a high power objective of this character, and can only cite the opinion of our Rochester opticians that such an objective of satisfactory correction and definition can be made.

Mr. A. L. Kean first used a small cell, made to contain 1 cubic millimetre, early in the winter of 1888-89, and attempted by the use of such a cell to arrive at a quantitative determination of the number of organisms present in a given sample. Such a cell was found to be altogether too small to furnish other than uncertain results, although it probably suggested the larger cell which has become of great value.

The use of sand as a filtering medium for this purpose was suggested by Desmond FitzGerald, Boston Water Works, but it was to the ingenuity of Prof. Sedgwick that we owe the working out of the really useful application of those various devices. My own subsequent improvements are in the nature of refinements of technique.

The practical value of a method of this character will be readily recognized by all who understand the limitations of chemical analysis as applied to the decision of questions relating to the sanitary value of potable water. The most useful of the various chemical methods recognizes only two classes of organic impurity, namely, free and albuminoid ammonia, and groups every organic substance occurring in water as one or the other of these. This has resulted in the condemning of the water of mountain streams by chemists who ventured positive opinions, as to sanitary value on the evidence of chemical analysis alone. The use of the biological method, by exhibiting clearly the character of the organic contamination, will, therefore, lead to a more accurate knowledge of potable waters than can be gained by chemical analysis.

Moreover, as we gain more knowledge of the real sanitary significance of the various forms of plant and animal life, the daily or weekly fluctuations in quality of a public water supply can be quickly obtained by the use of this method of biological analysis, and it is probable that in the very near future all public water supplies in this and adjoining States will be regularly subject to such examinations. Indeed, the State Boards of Health of the States of Massachusetts and Connecticut have already begun a series of examinations, either weekly or monthly, in their respective States, and in the city of Boston I have been engaged a portion of my time for the last eight months in supervising the details of beginning an elaborate study of this kind as applied to the Boston supply. The Boston Water Board, with liberal foresight, have recognized the value of such new methods of examination, and have provided liberally for a practical test extending over a number of years. Daily records have been made for the last six months and show results of great value, though the full value of such work can hardly be determined in so short a time. At a recent meeting of the New England Water-Works Association, Mr. F. F. Forbes, Superintendent of the Brookline, Massachusetts, Water Works, has given an interesting account of some similar studies which he made during the last season, with his results, and I will refer those interested to the Journal of that Association for further detail of such work.

[Mr. Rafter then adds some tables showing results of the use of his apparatus and a blank form for recording results.—EDITOR.]

---

**Figs in California.**—The fig tree which belongs mainly to the shores of the Mediterranean has been introduced into California. There are now 50 varieties under experimental cultivation, with the view to selecting the few best adapted to the coast. It is believed that by judicious selection of location and varieties fig culture will become a success in California.

## Radiolaria: Their Life-History and Their Classification.

BY REV. FRED'K B. CARTER,

MONTCLAIR, N. J.

[Read before the Department of Microscopy, Brooklyn Institute, February 16, 1892.]

For the life-history in general of the Radiolaria the reader is referred to the article on the Rhizopoda in the number of this periodical for January, 1888. In the main, the structure corresponds; that is to say, the essential part of the Radiolaria, as of all the other rhizopods, is the *protoplasmic substance*, and the action of this substance is the same in all. There is the same formation of pseudopods, the same use of them. Digestion and assimilation are effected in the same manner. It only remains therefore to point out certain features wherein the Radiolaria *differ* from the other orders of the rhizopods.

One of the most important is the *absence* of the contractile vacuole. This is never present in these forms,\* and it alone distinguishes them from the fresh-water rhizopods; but there is a still more important difference, namely, the *presence* of a *membranous central capsule sunk in their protoplasm*. This, says Lankester (in the Ency. Brit.), makes them a very strongly-marked group, definitely separated from all other rhizopods. This capsule is a perforated shell of membranous consistency, having protoplasm within it which is continuous through the pores or apertures of the capsule with the outer protoplasm. That is to say, in the *other* shelled rhizopods the main body of the protoplasm is all *within* the shell, but in *this* group it is *outside* as well as inside.

And this leads to the third distinction, which is the possession of a *skeleton* in addition to the inner shell. The fresh-water rhizopods, then, and also the Foraminifera group of the *marine* rhizopods, possess a shell, but the *Radiolaria* both *shell* and *skeleton*, and *between the shell and skeleton there is a mass of protoplasm such as does not exist outside the shell of the other groups*. The *skeleton*, then, is peculiar to these forms and deserves close attention on that account alone; but not only on that account, for it has an intrinsic value because of the wonderful beauty and variety of its shapes. "No other group of organisms," says Haeckel, "develops in the construction of their skeleton such a variety of fundamental forms with such geometrical regularity and such elegant architecture" (Leidy, Rhizopods). And a glance at Haeckel's magnificent plates, in his elaborate monograph on this group, is sufficient to show what an inexhaustible feast there is here for the eyes of the careful observer. "Sometimes," says Leidy, "it consists of a simple trellised ball, sometimes a series of several such balls, enclosed concentrically in one another, and connected together by radial bars. Generally delicate spines, often branching, radiate from the surface of the balls. In other instances, the skeleton consists of a star mostly composed of twenty spines, arranged in definite order and united in a common centre, or it is a delicate, many-chambered cell, as in the *Foraminifera*."

**Preparation.**—Procure a small lump of Barbadoes earth. Before you break it up note, by the way, how light it is. I had a lump which was a little over an inch square. It weighed but half an ounce, or 240 grains, and yet it contains thousands and tens of thousands of

\* Ency. Brit., Art. Protozoa.

these skeletons. Think, therefore, of the infinitesimal weight of each; nevertheless, though individually of so little account, materially they have formed a mass in the Barbadoes *1100 feet in thickness*, and stretching for a considerable distance.

Cut off now a piece about half an inch square and drop it in an ounce or two of boiling water, to which has been added a few crystals of carb. of soda, and let the material boil briskly for two or three minutes, stirring once or twice with a glass rod. This will dissolve the earth very thoroughly. Put aside to cool and then fill a long test-tube, or glass of about one-inch diameter, with water, and after shaking the material in the cup pour a little of it into the glass. Let it settle for 15-30 seconds and then pour off all but the sediment at the bottom. Pour that sediment into a small ounce bottle and repeat the operation. That will give you almost nothing but Radiolaria, and further separation will get rid of most of the broken shells. Do the same with another portion of the material and leave to settle for 1-2 *minutes* and then pour off as before. This will give you the smaller and lighter forms also, but some dirt as well as broken shells. Clean this still further, if necessary, and place in another ounce bottle. And that is all the preparation that is needed to yield you excellent material for study. There is nothing like the trouble about it that one finds in cleaning the Richmond earth, for example, for diatoms. The skeletons, by this simple process, are in fine order, except that the boiling has possibly broken off some of the spines. If you want to save them, boil the material *less*, or use simply hot water to dissolve the material, but in that case you will not get your forms so clean. A twelfth of an inch, or even less, of the cleaned material is enough for a half-ounce bottle. When this has well settled pour off half the water and add alcohol as in the case of diatoms.

**Mounting.**—Shake the bottle and take up a drop with the pipette and evaporate on a cover-glass placed on ferrotype plate over the lamp. Make a thin cell of rubber cement on the slide. Now dip the cover in a little benzole to get rid of air-bubbles, drain off with blotting-paper, add a drop of balsam, attach cover, and when the balsam is dry ring with rubber cement, Brunswick black, or King's cement, and the thing is done. Mr. D. B. Scott's method was to place the forms upon a slide, with a considerable quantity of balsam in benzole or chloroform, and lay the cover-glass over them. The balsam was then heated until the benzole or chloroform boiled very briskly, after which the slide was allowed to cool, and then finished as usual.\* I mention it here for the sake of those who may have some of the cleaned material *dry*. Where the forms are kept in water, however, and the water evaporated over the lamp, the subsequent boiling in benzole-balsam does not seem to succeed very well; at least this is my experience. Air-bubbles *will form* and *remain*, but by dipping the cover in benzole, after the forms are dried, there will be no air-bubbles. A further advantage is that the forms are dried on the cover, not on the slide, and that the forms, being in alcohol and water, are more evenly distributed in drying than when boiled in benzole-balsam, so that on the whole this method seems preferable.

(*To be continued.*)

\*See Jour. for Aug., 1883, p. 144.

## EDITORIAL.

---

*All communications for this Journal, whether relating to business or to editorial matters, and all books, pamphlets, exchanges, etc., should be addressed to American Monthly Microscopical Journal, Washington, D. C.*

Dr. Ray Lankester, of Oxford University, is rather severe on the new edition of Carpenter in his review in *Nature*.

While saying that the part written by Dr. Dallinger is of high scientific value, and by far the best on the subject, "one which every worker with the microscope should thoroughly study," he says that the work "has lost its authoritative character, and is more than ever a patchwork of paragraphs on arbitrarily selected subjects, the responsibility for which is divided in some mysterious way between the editor and certain Fellows of the R. M. Society. There can be no doubt that Prof. Bell would have written an excellent original treatise on microscopic animals, and Mr. Bennett an equally valuable one on plants, but they have not been asked to do this. They and others have contributed fragments, which are mixed up with fragments of the original Carpenter in inextricable confusion."

The answer to this criticism of course is easy—that Dr. Dallinger assumes responsibility for the entire volume, except where Prof. Bell or others are made responsible. Dr. Carpenter's responsibility has ceased and been taken up by the revisors. What matters it whether the new has been patched upon the old so skilfully that one cannot distinguish? The indications are that Ray Lankester feels piqued a little over something connected with the volume, and yet we ought not to see any exhibition of feeling from so honorable a seat of learning as Oxford.

Prof. H. L. Tolman, president of the Illinois State Microscopical Society, has consented to become one of our collaborators for 1892, and to contribute to each number.

In the present issue will be found, under New Publications, a notice of the new edition of Carpenter on the microscope. The size of pen that this distinguished writer wields may be judged from this review.

---

## MICROSCOPICAL APPARATUS.

---

**Edinger's Drawing Apparatus for Low Magnification.**—Dr. Ludwig Edinger, of Frankfort-on-the-Main, has devised a drawing apparatus which he presented at the Southwest German Society for Neurology and Psychiatry, June 7, 1891, the account of which by Dr. Jos. Collins we extract from the *New York Medical Journal* of January 16, 1892.

The apparatus is based on the projection principle, and consists of a stand bearing an upright which supports a tube or cylinder parallel to the base, and in opposition to a piece of canvas-board which cuts off all the rays of light, excepting those passing through the cylinder.

The front surface of the upright has a metal groove into which is fitted at its upper part an arm terminating at the other end in a circular plate for the support of the object to be drawn. Beneath this is a second arm, also fitted into the groove, terminating in a small cylinder for the

reception of the lens. Both of these arms are movable, but the upper one should remain fixed. Moving the other will focus the rays of light and make larger or smaller representations of the preparation according to its distance from the object-bearer. The light used may be either sunlight or artificial.

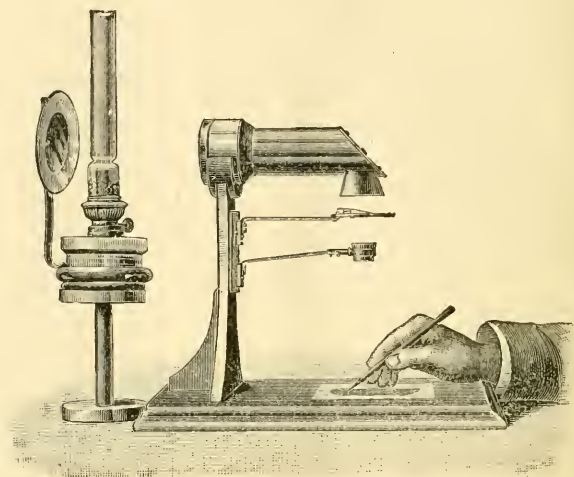

As a rule, an ordinary lamp, with or without a small reflector, answers all purposes. The light being placed in the proper position, and the preparation to be drawn on the object-table, a sharply outlined picture of the preparation will be thrown on a piece of drawing-paper beneath. By regulating the height of the arm bearing the lens, or by changing the lens, any magnification between two and fifteen times can be made.

In this way the outlines of an absolutely true drawing can be made and the details filled in from the microscope, or a precise picture can be made from the apparatus alone, so sharply defined is the representation.

Of course specimens colored with dark stains give more clearly differentiated pictures than the light ones.

The instrument is made by Meyrowitz Brothers, of New York, to whom we are indebted for the cut, and may be had with two or three lenses. Two are all that are necessary ordinarily, but the third is important sometimes when the object to be drawn is very small.

**Continental Apparatus in England.**—The French and German instruments and objectives were first brought into England because they could be obtained for about one-fourth the price exacted at that time by English makers for instruments of no greater practical value. English dealers (not the great makers) were in the habit of taking inferior objectives which had been rejected by their makers, and selling them as their own make at higher prices than would suffice to purchase first-class glasses from the Continental firms themselves.—*Ray Lankester in Nature.*



**Durkee's Electric Illuminator.**—The illuminators heretofore presented in this periodical have all made use of oil as a means of producing light. A neat and not very expensive illuminator is now presented which depends on electricity for the light.



This illuminator may be attached to the mirror-bar of any microscope having a swinging bar, and be employed for central or oblique illumination. The construction is such that when the lamp is burned out it can be replaced at small expense. It is provided with a pin-hole diaphragm, cutting off all rays except those passing through the object, a condensing lens, and a disc of blue glass.

The lamp used is a 4-volt one and may be lighted from a two cell storage battery or from 4 to 5 LeClanche cells. For use with high powers it gives a very strong and steady white light, assisting materially in the resolution of difficult test diatoms, and bringing out the finer details of histological work.

The cut represents two-thirds its actual size. It is made by the McIntosh Battery Co., Chicago.

**Photomicrographs of Diatoms.**—Messrs. Trann and Witt, in their work on the fossil diatoms of Hayti, describe their method of photography. They first photograph the diatoms with a magnification of about 100 diameters, and afterwards enlarge the negatives so as to obtain a photograph magnified 500 diameters, proper for photo printing. Fine details are said to be brought out which are invisible to the naked eye in the smaller photograph.—*The Microscope*.

**Photomicrography.**—In an address upon photography, Prof. R. Meldola, F. R. S., said there is no reason why the dry plate, which has already largely superseded the eye in astronomy, should not also relieve the eye of the microscopist. Many biological works have been illustrated with great success by means of photomicrography, and even in purely systematic works photographic illustration has been adopted with success. In studying microscopic forms of life where an evanescent plate of life-history may be full of profound significance, the photographic plate might well replace the eye in those cases where prolonged and fatiguing observation has hitherto been found necessary.

## MICROSCOPICAL MANIPULATION.

**Cutting Glass Tubes, Bottles, etc.**—Wrap two bands of thick blotting-paper around the vessel, leaving less than  $\frac{1}{4}$ -inch between them at the place to be cut. The paper is applied while wet and is cut  $\frac{1}{4}$  to  $\frac{1}{2}$ -inch wide. If the article to be cut is large, leave more than  $\frac{1}{4}$ -inch between the wet bands. Apply a fine flame from 2 to 3 inches long to the glass between the wet bands, slowly revolving the bottle or tube and keeping the flame steadily on the glass. The clean cut along this line is rapid and very satisfactory. Prof. Wm. Thompson devised the process.

**Cement** for joining parts of apparatus so that they will be permanent, solid, and waterproof, resisting heat, oil, and acid, is made by mixing

concentrated strupous glycerine with finely-powdered litharge to a thick, viscid paste, which may be applied like gypsum. Glass, metal, and wood all unite under its influence.

**Mounting Stentors and Spirostomum by the use of Hydroxylamine.**—Place the objects for ten or fifteen minutes in a 0.25 per cent. solution of the hydrochlorate. A large proportion of the animals soon stretch themselves out and remain in the semi-distended condition which free-swimming Stentors usually show. No subsequent contraction occurs. The paralyzing effect of the hydroxylamine is soon apparent, but is, however, not sufficiently complete to commence the fixing process. The paralysis must first extend to the cilia. After some ten minutes the cilia of the peristome move irregularly and slower, and finally cease moving altogether. This change must be carefully noted, for at this step the Stentors are suddenly flooded with a concentrated solution of picric acid mixed with a 5 per cent. solution of acetic acid. The majority of the Stentors are now pear-shaped; a few are distended their full length; while others have the same round shape ever, at the right moment, the histological details will be preserved. The Stentors may then be washed in alcohol of 70 per cent., and stained in a rose-red solution of borax-carmin in hydrochloric alcohol of 70 per cent. A satisfactory stain will be obtained in about one hour's time. The Stentors being likely to contract if transferred from absolute alcohol directly to the oil of cloves, it is advisable to place them in oil of cloves strongly diluted with absolute alcohol, which latter is allowed to evaporate. This proceeding must be followed when mounting the specimens in Canada balsam. If all the above-mentioned details are adhered to, better slides will be obtained than have been produced by any other method.—*J. N. T. M. Soc.*

## DETECTING CRIME WITH THE MICROSCOPE.

**Examining Garments.**—The detection of crime, where stained undergarments are involved, is an important but often a difficult matter. The whole case may turn upon whether or not a stain consists of mere "dirt," or whether it contains the minute zoöids derived from the male generative organs. The demonstrating of these organisms may substantiate or it may refute the verbal testimony of witnesses. Any physician is liable to be consulted on this point, and, if a good microscopist, to become of great assistance to the court. An experienced worker, Mr. H. Shimer, sends us the following:

There is probably no better method of preparation than to make thin sections with a sharp razor, after drawing the cloth in the suspected spot over a curved surface. The bottom of a teaspoon is very good. With the razor, cut thin sections of the curved cloth, instead of a thin flat section, as of some organic tissues the material crumbles on the razor into a fine powder. Scrape this upon a slide. Mix and distribute it in water. Allow it to dry. It may be examined at any time. The mount will be improved by staining after drying. One grain of eosine to an ounce of alcohol will stain with much satisfaction. Flowing a drop of the eosine solution over the mount and allowing it to dry brings out the zoöids so that they can be seen on the cloth fibres

as well as in the spaces between the shavings of the cloth, where they have floated out in the fluid. One can examine it without a cover, or it may be preserved a long time uncovered, but if desirable to cover make a dry mount. The eosine staining does not bear much washing on account of the floating off of the objects. I therefore use very dilute eosine, 1 grain to 1 ounce, or even 1 grain to 4 ounces. This stains enough, and needs no washing. Stains made with gentian violet should be mounted in Farrant's medium; the violet shows plainly at first but soon fades out; those mounted in balsam are very pale but plain. Woolen garments sectioned with a razor, stained in eosine, and mounted in balsam exhibit very nicely the zooids on the woolen fibres: the fibres of wool seem to clear up enough to show the objects lying closely on the hairs of the wool in great numbers. If mounted in Farrant's medium it appears equally well.

Advice not to wash the suspected spot is in a certain sense a good one, but if the washing is properly done it may be efficient. Place a few drops of a normal saline solution, or in its absence a little water, in a small dish, moisten the spot from the opposite side by laying it in the solution a minute, lay it away a short time (10 or 15 minutes), not allowing it to dry, insert it on the slide, and moisten it a little more by dipping the end of the finger in the solution and gently tapping the cloth a few times on the slide with the ball of the finger; dry and examine; this method sometimes gives excellent results. If we wring the moistened spot so as to let fall a few drops of turbid fluid on the slide, it might from the appearance suggest promising results, but when we come to examine it the objects are obscured too much by the vast amount of debris. Dry and examine as before, or after drying stain with the eosine as above. This method demonstrates the zooids a long time after drying. Many of them may be tailless, but a great many can be seen in perfect form.

If the eosine solution is too strong the debris, saline precipitate, and dirt on the slide will be too deeply stained, and thus interfere with the examination. In this case careful washing by flowing over the slide a little water is often an improvement if done after the stain has dried.

If the garment has been handled much, so that the surface has been worn off, the razor sectioning must be resorted to to get the forms that have lodged deep in the meshes of the cloth, and it is better to use both methods, trying each on a separate piece of the suspected spot.

Elegant preparations have been made by moistening the cloth with chloride of sodium, 2 grains; phosphate of soda, 1 grain; water, 1 ounce; to which add carbolic acid, 1 drop, to preserve the solution. Transfer to the slide as above directed. After drying, stain with eosine, 1 g. to the ounce. After this is dry, dip the slide carefully (mount up) just under the surface of a dish of water. Drain off quickly and allow this to dry. This removes the stain diffused all over the slide, but allows it to remain in the zooids, which now stand out in bold relief under a dry  $\frac{1}{2}$  objective and 1-inch eye-piece, the heads deeply stained, and the tails in many unbroken. Of course there is a good deal of debris that is also finely stained and scattered all about over the slide in every field, but he who understands what he is looking for will readily differentiate between the "dirt" and the organisms.

**BIOLOGICAL NOTES.**

**Growth of Seeds.**—Dr. Leicester, of Bristol, has found seeds to germinate with surprising rapidity in electrified earth. He filled with soil a box (3 x 2½ feet) and placing at the ends metal plates, one zinc and one copper (1 x 1 foot), and uniting them on the outside with copper wire, by a slow chemical action on the zinc a current passed through the earth towards the copper and returned through the outside copper wire. This is the minimum of apparatus and the simplest of cells.

Seeds were then sown in the electrified earth. Similar use was made of glass tanks filled with earth. The supply of moisture and other conditions being the same, an electrified tank germinated hemp seed so soon that the sprout was an inch out of ground before seed in a non-electrified vessel showed signs of sprouting. A little very dilute acetic acid sprinkled on the soil of the electrified earth still further accelerated the growth, though it produced no effect in the non-electrified tanks.

**Digging Powers of the Newly-Discovered Mole.**—The *Notoryctes* burrows obliquely in the sand, going two or three inches under the ground, and never betraying its passage except by a slight undulation of the soil. In digging it uses its conical nose, which is protected by a horny plate, and the strong, mattock-shaped claws of its fore feet. The hind feet, which are wider and spade-shaped, throw the sand back so that no trace is left of the tunnel which it hollows. It comes to the surface a few yards farther on, and then buries itself again, all without making any noise. It is prodigiously agile and swift, a property on which Mr. Benham, who lived for some time at Idracowra, says: "Everybody here can tell you how some one of these animals will get away by digging in the sand. I had brought a live one to the house and we were talking of its agility in digging. Mr. Stokes desired to see it at work. After spading and turning over the ground near the house, we set the animal down; I held it in my hands till it was nearly hidden, and then tried to overtake it by scratching the ground behind it, but it was quicker than I. I took a shovel and tried to find it, but without success. Another man came to my help with a second shovel, and also a native woman used to digging in the ground with her hands. But all three of us could not find it."—*From The Australian Marsupial Mole*, by DR. E. TROUSSERT, in *The Popular Science Monthly for March*.

**The Fresh-Water Sponges** of the Mills Collection have been reported on by our collaborator, Prof. D. S. Kellicott, for the Buffalo Society of Natural History. From the bulletin containing his paper the following may interest microscopists:

The vicinity of Buffalo is especially favorable as a collecting ground for fresh-water animals. Additionally to the lake and large river there are small rivers, swamps, and creeks. "These are teeming with a vast variety of microscopic plants and animals, from early summer to December." These conditions are especially favorable to the growth of sponges, and here they are found in remarkable abundance."

The specimens had been dried. To re-examine them "a row of watch-glasses, each with a few drops of carbolic acid, were placed on the work-table and a selected fragment of sponge placed in each, with proper numbering to prevent confusion. After a short interval, exam-

ination could be commenced. This was done by transferring material to ordinary slides and examining in the acid. The statoblasts were soon sufficiently transparent to permit a determination of the structure by a  $\frac{1}{4}$  inch objective."

**The Cotton Crop** of the United States for fifty years is fully treated in the *American Agriculturist* for January. It gives the crop in bales, total consumption, exports, weight per bale, gross and net, and average price per pound on the plantation, exported at New York and at Liverpool; also the acres planted, the total yield in pounds, the average per acre in pounds and bales, total value of crop and value per acre. The United States live-stock census from 1840 to 1890, inclusive, is also given, together with the grain census for the same years. This is supplemented with tables showing for oats, corn, and wheat the acres grown in each State in 1891, compared with the average for the five previous years, the yield per acre in 1891 and 1890 and in the five previous years; and the same regarding the total crop, prices on the farm, and total value. This is supplemented by tables showing our agricultural exports and imports and the exports in detail.

**Crustaceous Parasites of Fishes** are desired by Professor Kellcott for his exhibit at Chicago in 1893. Those interested are desired to read his request among the Want, Sale, and Exchange notices.

---

## DIATOMS.

---

**Life History—their Classification.**—An article with this title recently appeared in this *Journal* (vol. xi, pp. 276–280 and xii, 1–6, 81–85, 97–101, 121–123). The *Torrey Bulletin* for January, 1892, pp. 27–28, contains the following criticisms by C. Henry Kain, of Philadelphia. After commending in high terms a part of the paper he indicates a few errors or inaccuracies, of which our readers should have the benefit.

"The division into fresh water and marine genera is not at all a happy one. Of the 34 genera enumerated as fresh water, 11 are also marine while 2 others are exclusively marine (*Terpsinoë* and *Schizonema*). Nearly all the species of *Pleurosigma* are either marine or brackish. Some of the most interesting forms commonly found in marine collections are absent from the list of marine genera (*Coscinodiscus*, *Amphiprova*, *Actinoptychus* and *Actinocyclus*).

"In telling how to distinguish *Campylodiscus*, *Surirella*, and *Cymatopleura*, the statement is that if the frustule is twisted the specimen is *Campylodiscus*, but the other two forms are frequently twisted. The old term, "saddle-shaped," would be a more expressive one.

He says that there is certainly no better guide to the determination of genera than is given by H. L. Smith in the "Conspectus of the Diatomaceæ," which has been reprinted in Wolle's *Diatomaceæ* of North America.

---

## BACTERIOLOGY.

---

**The Influenza Bacillus.**—At the Academy of Medicine in Paris (Feb. 9) Cornil and Chantemesse performed an interesting experi-

ment. A drop of blood taken from an influenza patient (an infant) was inoculated into a vein of a rabbit (No. 1). The next day the blood of the rabbit contained microbes corresponding to those described by Pfeiffer, of Berlin. They were very small and more difficult to be seen than those found in septicæmia in the rabbit, but capable of being stained by methylene-blue and fuchsin in Ziehl's solution. They measured 1-20th the diameter of red blood discs in length. The blood of this rabbit gave characteristic cultures on sweetened agar-agar. These cultures were used to inoculate another rabbit (No. 2), and its blood soon contained a similar bacillus, which was easily cultivated in sweetened bouillon. From the rabbit the virus was transferred to a monkey, a few drops of the bouillon culture being placed in the nasal fossæ, but as the injection probably penetrated into the pharynx and was swallowed the symptoms were only diarrhœa, fever, weakness, and depression.

The same micro-organisms were found in sputa and blood of several influenza patients, not only during the fever climax but for days afterward. Blood from one of these patients was injected into the vein of a rabbit (No. 3) with results as in previous cases. The bacillus remained in the blood of the rabbits for over three weeks.

The bacillus is so small and so difficult to stain as to elude much carefulness. It cultivates slowly at 37 C. in agar-agar or in bouillon, and yields to reculture in artificial media. After 24 hours the agar-agar culture appears as a very fine pink cloud-like outline. In bouillon the culture is scarcely visible to the naked eye. These media preserve their transparency in presence of the culture, but interspersed with very fine granules. (See *Lancet*, Feb. 13, 1892.)

**Useful Work.**—The microscope has discovered numerous organic and functional derangements, for many of which there is yet no absolute remedy, and for some of which there probably never will be, and we hear the inquiry: If it cannot cure, of what good is it to point out disease? It is a great step in advance to discover any heretofore unknown malady which can affect the human species, and the discovery is the first step towards remedy.

---

## RECREATIVE MICROSCOPY.

**Soirées.**—The Washington Society has appointed a committee, of which our distinguished friend, Prof. Seaman, is chairman, to prepare a soirée for some evening in April or May.

At the meeting of February 17, the San Francisco Society gave a public exhibition which was a great success. The display of objects was made as general and unprofessional in its nature as possible, and consequently the range was very wide.

Professor Hanks exhibited a very interesting slide of minerals "salted" with filings from gold coin. Under a moderate power the very file-marks upon the particles of gold were perfectly evident, and by an examination one could, with certainty, pronounce the specimens "salted." He also showed ashes from the eruption of Krakatoa in 1883, and one of the most wonderful pieces of microscopic engraving ever executed. In a space 10 x 25 millimeters were 32 lines of engraved words averag-

ing 18 words per line. Henry C. Hyde showed an interesting series of chemical crystals, and a volume of photographs in 59 large plates of Möller's wonderful collection of diatoms. The collection embraces upwards of 4,000 named varieties and is valued at \$10,000. J. G. Clark showed various specimens of crystals of gold and silver, both native and produced by the galvanic current. L. M. King had under his microscope many forms of diatoms *in situ*, while S. E. Taylor had a fine assortment of arranged diatom slides from the laboratory of Thum, Leipsic. George Otis Mitchell confined his attention to insect eggs and the apparatus for placing them in position, including the wonderful saw by which the fly inserts its eggs under the cuticle of various leaves. E. W. Runyon had a well-assorted list of objects shown by dark-field illumination, and several objects from the animal kingdom under polarized light.

### MEDICAL MICROSCOPY.

**The Klebs-Loeffler Bacillus and Associated Forms.**—Our bacteriologists are doing splendid work in the study of the microorganisms of diphtheria. A decade of such work (perhaps less) will place our knowledge of these malignant plants on a solid basis.

Meanwhile, the fact remains that we have as yet no certain test which can be applied by the ordinary practitioner or microscopist to distinguish Loeffler's bacillus diphtheriæ from the so-called pseudo-diphtheritic bacilli which are associated with non-malignant angina. Even if the experts were thoroughly agreed about points of differentiation—and they are not—the necessary tests occupy several days, and the most conclusive is inoculation.

The most urgent question is whether the pseudo-diphtheritic bacillus may not be an attenuate form of the true bacillus diphtheriæ, and capable of developing malignant powers under circumstances favorable to itself. If this question be answered in the affirmative, then the question comes, Does the case of follicular tonsilitis require the same careful isolation as a case of true diphtheria?—*F. Blanchard, M.D.*

**The Water Supply of Washington.**—During the past three months our hydrant water has certainly presented an alarming appearance. Doubtless many physicians have been asked by their patrons whether the water is really as sick as it looks. Now, it is not as pathogenically bad as it looks; but it may be bad, and the family physician will do well to give a guarded answer to such questions.

The chief cause of its turbid, milky appearance is clay, in the form of almost impalpable powder. The frost disintegrates the clayey banks of the Potomac; the heavy autumn rains wash the fine particles into the river; and, as the specific gravity of clay is low, no ordinary process of settling suffices to separate it from the water. Filtration through the excellent filters now in the market accomplishes this on a small scale; and probably filtration through large beds of sand would do the same for the whole mass of water supplied to the city.

But clay alone is not a very dangerous addition to our diet. The live question is, Does the clay bring along with it other matter which is really morbid? We should naturally expect that it might, and

that among the passengers who would be likely to come by the same train with Mr. Clay would be the germs of malarial and typhoid fever.

In the spring-time even low powers will show that it is well stocked with amœbæ, but we do not suppose that these are injurious to health.—*F. Blanchard, M.D.*

---

### MICROSCOPICAL NEWS.

**Microscopy at the Columbian Exposition.**—A committee has been appointed whose duty it will be to arrange for a suitable exhibit of microscopes, micro-organisms and books at the Columbian Exhibition. A large room will be provided which will be under the supervision of the American Society of Microscopists and the local committee, and the co-operation of the other societies will be asked.

**A Bargain List** of Microscopes, etc., has been issued by Geo. S. Woolman, 116 Fulton st., New York, of which he will send a copy to applicants.

**Dr. Chas. P. Pengra**, professor of Dental Histology and Microscopy in the Boston Dental College, died in Boston, Jan. 31, 1892, aged 31 years. In 1883 he received degree of Phar. Chemist from the Michigan State University. In 1884 he assumed the chair of Materia Medica and Botany in the Massachusetts College of Pharmacy in Boston.

---

### CORRESPONDENCE.

The White's specimen sent me is superb.—*Prof C. T. McClintock, Fort Smith, Ark.*

The White's botanical sections are real beauties.—*A. F. Bartges, Akron, Ohio.*

---

### MICROSCOPICAL SOCIETIES.

SAN FRANCISCO, CAL.—*WM. E. LOY, Sec'y.*

*January 6, 1892.*—J. C. Spencer, M. D., was elected to membership. Ed. M. Ehrhorn presented a complete set of the transactions and bulletins of the State Board of Horticulture. Arthur M. Edwards, M. D., Newark, N. J., presented a report on infusorial earths from the Pacific Coast.

Henry G. Hanks read an interesting paper on an animal concretion (*biliary calculus*), presented to the Society some years ago by Colonel Kinne. The specimen, which is the size of a walnut, of irregular form, was removed from the kidney of a cow. From its golden lustre it was thought to be largely composed of gold dust. The pasture lot where the innocent bovine had fed and thrived suddenly became an object of interest, and the residents of the vicinity concluded that the ground was teeming with the yellow metal. So confident were the old miners that the piece of ground suddenly became valuable in their eyes, and the excitement did not subside until an acre lot which could not have been sold for \$50 changed hands at something more than \$2,000.



Mr. Hanks stated that the metallic lustre was not owing to the presence of gold or other metal, but entirely to its laminated structure, like the pearl. A microscopic examination revealed its structure plainly, and the lines of concentric rings were visible. If the entire mass should be cut into sections or disintegrated, the nucleus would be found around and upon which the layers were deposited.

Concretions, or *calculi*, are found in many animals and in different organs of the body. They differ according to the part in which they are found and to the food of the animal. Those found in the carnivorous animals resemble those found in man, and differ from those found in animals which feed only on vegetables. They are mainly phosphate of lime, phosphate of magnesia, or ammonia phosphate of magnesia.

The Corresponding Secretary reported the receipt of two donations of diatomaceous material. The first was sent by K. M. Cunningham from Mobile, Ala. The second donation was from a peat-bog near Amherst, Nova Scotia, and was referred to Mr. Breckenfeld to examine.

*February 3, 1892.*—This being the annual meeting, called out a good attendance. The Treasurer's report showed a net gain of twenty members during the past year, and after paying all the expenses of fitting up the new rooms and apparatus there remained on hand almost \$300. Dr. S. M. Mouser, who has been a member of the Society for nineteen years, was made an honorary member.

The election of officers resulted as follows: President, A. H. Breckenfeld; Vice-President, Dr. J. M. Selfridge; Recording Secretary, William E. Loy; Corresponding Secretary, George O. Mitchell; Treasurer, Charles C. Riedy. Of these officers the Vice-President, Recording Secretary, and Treasurer were re-elected; a vote of thanks was accorded to the officers of the past year, to whose untiring energy so much of the Society's prosperity was due.

Dr. M. C. O'Toole read a very interesting paper on "Observations on Structural Changes in Diseases of the Heart," illustrated with microscopic specimens.

The preparations shown by Dr. O'Toole were made from the heart of a lawyer who died about fifteen years ago. A contest by the life insurance company, which disputed the liability on account of some peculiar phases of the death, led to an expert examination of the organ, with the result that a jury promptly gave judgment for the widow and against the contesting company.

Dr. Jacobs exhibited a longitudinal tooth section, and made some interesting statements regarding tooth structure and tooth diseases.

#### MICROSCOPICAL SOCIETY OF CALCUTTA.

*1891.*—This was the 4th year of this Society, during which papers were read by W. J. Simmons on (1) *Englena viridis*, (2) a verticulated amœba, (3) micro-organisms in the General's tank. (4) rights and obligations of members; by J. Wood Mason on (1) a method of investigating living infusoria, (2) *Clathrulina elegans*; by W. J. Simpson on (1) cultivations on sterilized potatoes of certain organisms; by T. H. Holland on (1) centering of high powers of the microscope, (2) embryology and growth of crystals; by W. M. Osmond an exhibition of photo-micrographs.

The Society has 78 members, of which 16 are charter members, and

many are inactive. Eight meetings were held during the year, with an average attendance of about 10 members; J. Wood Mason was President and W. J. Simmons, Honorary Secretary. The cash receipts for 1891 were 245 rupees (\$122.50), and the expenses 426 rupees (\$213), the printing of an excellent bulletin having absorbed most of the accumulations of previous years. The Society is to be commended for its activity in natural history and its contributions to biology.

#### NEW YORK MICROSCOPICAL SOCIETY.

The following officers were elected for the year 1892: President, J. D. Hyatt; Vice-President, Charles S. Shultz; Treasurer, James Walker; Recording Secretary, George E. Ashby; Corresponding Secretary, J. L. Zabriskie.

### NEW PUBLICATIONS.

*The Microscope and its Revelations.* By the late Wm. B. Carpenter. Seventh edition. Revised by Rev. W. H. Dallinger, LL.D. 1099 pp., 21 plates, 800 engravings. American edition, P. Blakiston, Son & Co., Phila., 1891. \$6.50.

The appearance of a new edition of Dr. Carpenter's well-known work on "The Microscope and its Revelations," marks an era in the history of technical works on the microscope, and deserves a more extended notice than can be given it within the limits of a magazine article. It is without a rival in its particular field, and is beyond question the best single work on the subject, not only in English but in any other language. Its object has been, as stated in the preface, "to provide the elements of the theory and principles involved in the construction of the instrument itself, the nature of its latest appliances, and the proper conditions on which they can be employed with the best results. Beyond this it should provide an outline of the latest and best modes of preparing, examining, and mounting objects, and glance, with this purpose in view, at what is easily accessible for the requirements of the amateur in the entire organic and inorganic kingdom."

But this is only a part of what has been done. The whole subject of the optics of the microscope has been carefully reviewed and the most modern doctrine stated anew, leaving out almost entirely the antiquated and erroneous theories of angular aperture, etc., which are now justly relegated to the volumes of ancient history.

The present edition has been edited by Dr. W. H. Dallinger, who has wholly rewritten the first five chapters and added two entirely new ones. The remainder of the work also bears the marks of strong personality, showing that it is substantially a new treatise. The order in which the subjects are treated is unfortunate. It is not inspiring to be plunged into columns of figures within the first dozen pages of the work and then compelled to read a long historical account of the origin and development of the microscope before the student reaches the subject which naturally interests him most—the way in which to use a modern microscope. The consideration of purely abstract questions, such as optics and the theory of microscopical vision, should, it seems to us, have been postponed until after some instruction

had been given as to how to see at all. One of the most novel and at the same time important portions of the work is the discussion on the modern theory of microscopical vision, to the elucidation of which Dr. Abbe has done so much. Sixty pages are devoted to this topic, and the subject is very ably treated. In some respects it is not as clear as the excellent article by Frank Crisp published in 1881 in the *Royal Microscopical Journal*, while in many other ways it is much superior, Dr. Dallinger having had the advantage of all of Dr. Abbe's latest investigations in the same line. The illustrations, many of them partly colored, add greatly to the value of the article, which, having been revised by Dr. Abbe himself, must be regarded as the most authoritative as well as the latest exposition of this very important and difficult subject. There can be little successful work done with high-power and wide-angled objectives without a clear and thorough knowledge of the laws of microscopical vision, for, as Dr. Dallinger well shows, not only is it possible to produce totally different appearances in an object by varying the illumination and collar adjustment, but the observer will be totally unable to decide which is the true and which is the spurious image without a knowledge of optics. The author says: "We learn that dissimilar structures will give identical microscopical images when the difference of their diffractive effect is removed, and conversely similar structures may give dissimilar images when their diffractive images are made dissimilar. A purely dioptric image answers point for point to the object on the stage, and therefore enables a safe inference to be drawn as to the true nature of that object; but the diffraction or interference images of minute structure stand in no direct relation to the nature of the object, and are not of necessity conformable to it. \* \* \* Minute structural details are not imaged by the microscope geometrically or dioptrically, and cannot be interpreted as images of material forms, but only as signs of material differences of composition of the particles composing the object, so that nothing more can safely be inferred from the image as presented to the eye than the presence in the object of such structural peculiarities as will produce the specific diffraction phenomena on which the images depend." This is not consoling, especially as the author adds, "our finest homogeneous objectives of greatest aperture inevitably fail to reveal to us the real structure of the finer kinds of diatom valves." It would be interesting and profitable could Dr. Abbe find time to tell us by theory how much our widest angled objectives vary from the truth; that is, for instance, what would be the shape given to a series of minute circular or hemispherical dots by an objective of 1.30, 1.35, and 1.40 N. A. Also, to show if there is any ratio or connection between the spectra shown and the real shape, so that we can deduce the one from the other. Inasmuch as a true picture can only be had by the utilization of all the diffracted rays, and as no objective can ever be made which will contain them all, can theory tell us how near the truth we get with our present lenses? It is known that with a dry  $\frac{1}{8}$  objective, for instance, the rays beyond about  $130^\circ$  or  $140^\circ$  air angle are of little value in the representation of form—does the same rule apply with diffraction images. If the diffraction fan is homogeneous, that is, if the rays are equally spread, then the loss of, say,  $30^\circ$  of angle out of  $180^\circ$  would cause an error of  $16\frac{2}{3}$  per cent., while in a medium power dry

glass it might almost be inappreciable. When the elements of a minute structure are reduced to only a few wave-lengths apart, the whole diffraction fan is spread out over more than  $180^\circ$  in glass, so that a medium of a higher refractive index must be used to condense them within the limits of any objective.

The full force of the Abbe theory, however, is only realized when it is considered that not only must the objective be of the largest angle to take in these widely diverging diffraction spectra, but that with them must also be combined at the same time the dioptric image formed by the central rays. "The images which are obtained with oblique light will always be incomplete, and not similar to a geometrical projection of the object, and generally (though not always) more dissimilar than those by central light in regard to the minuter details. Strictly similar images can not be expected, except with a central illumination with a narrow incident pencil, because this is the necessary condition for the possible admission of the whole of the diffracted light." This requires that the objective shall be so accurately corrected that the chromatic and spherical aberrations shall be completely eliminated, so that the central and peripheral rays can be utilized without change of focus. How few even of the best objectives fulfil this requirement every worker knows only too well. Here any superiority of the Zeiss apochromatics will be shown. It must, however, be remembered, first, that the difference in degree between the performance of the best American and English achromatic lenses and the Zeiss apochromatics is often only detectable by the experienced eye; and, second, that the vast bulk of microscopical work is done with medium or low powers, where the diffracted beams play a much less important part proportionately, the image being chiefly dioptric. As to the first point, the writer may even go further and say that it is a contested point among many of the highest authorities in America whether the Zeiss apochromatics have any marked practical superiority. The student may rest contented, therefore, that he can work for an indefinite time with any good American or English lenses without losing his time or running any serious risk of making mistakes in what he sees. This undue praise of Abbe and Zeiss is a serious fault in so able and catholic a writer as Dr. Dallinger, and the repeated allusions to them suggests there is some personal debt to be paid, and the distinguished editor seems to be somewhat over anxious to cancel his obligations. On the the other hand, his condemnation of the cramped, awkward, continental form of stand will be appreciated, and it is to be hoped will check the present craze—for it is little else—for that form of instrument.

There are many other topics which ought to be treated, but there is not room in the present article to more than allude to them. The criticism of the swinging sub-stage is too wide and sweeping, the necessity of high-angled achromatic condensers for all work, so emphatically urged, is a doubtful question, the condemnation of the Ross-Zentmayer arm and its accompanying form of fine adjustment seems too broad, and the recognition of American work and workers quite too scanty to be fair. Strange to say, the subject of photo-micrography has been entirely neglected.

The portion devoted to practical methods is very good, though so brief that the student will still need the help of such aids as Martin,

Lee, Paulsen, and other specialists. But it is terse and clear, and gives a good *résumé* of how to work.

The bulk of the volume, comprising over 560 pages, is given up to the application of the microscope in various branches of science, beginning with unicellular organism and extending to the histology of the human body. Many of the chapters are compilations of recent monographs on the same subjects, and all can be relied on as containing the latest scientific discoveries. The execution of the work is a little unequal in strength, some of the subjects being more thoroughly digested than others, but the task was a very difficult one, and the editor has shown rare self-restraint and ability in selecting from the vast body of scientific data only those which illustrate the use of the microscope.

No notice of this great work would be complete without a reference to the beautiful illustrations. Many of them are old friends, but many others are now seen for the first time. Probably the most striking one is a photographic reproduction of Dr. Van Heurck's resolution of amphipleura pellucida into beads with the famous Zeiss objective of 1.60 N. A. Another even more astonishing picture is a full page illustration of *Pleurosigma angulatum*, magnified 4,900 diameters. Many of the 21 lithographs are colored, and with the 800 wood-cuts make up a splendid specimen of the book-maker's art, and bear a worthy tribute to the ability and enterprise of the editor.—H. L. T.

*Quintus Curtius*. Edited by Dr. Harold N. Fowler, of Phillips Exeter Academy. Boston, Ginn & Company. Pp. 96, price 30 cents.

This book has been preferred on account of the conviction of the editor that for practice in sight-reading some continuous prose narrative not readily accessible in a copiously annotated edition should be in the hands of the pupil. The notes of this edition are confined to translations of unusual or striking words and phrases, with occasional brief hints concerning syntax, the main object of which is to save time in the class-room. In the introduction, Professor James B. Greenough shows by examples the method to be pursued in reading at sight, besides explaining fully his ideas on the subject.

*P. Terenti Afri Heavton Timorvmenos*. Edited by John C. Rolfe. Boston, Ginn & Co. Pp. 62.

This play in text of Dziatzko is issued for sight reading by the Freshmen in Harvard College. It will be useful elsewhere, and its cheapness must commend itself to all teachers of Latin. The story of Menedemus, who interfered in his son's love-making, is of enough interest to help study.

*P. Terenti Afri Phormio*. Edited by Frank W. Nicholson. Boston, Ginn & Co. Pp. 66.

This is another neat hand-book for sight reading in college classes. The editor is an instructor in Harvard College. A sufficient synopsis of each scene precedes each scene, and the text is not difficult.

*McIntosh Battery and Optical Co.'s Catalogue*.

This 14th edition is finely illustrated and includes a great variety of electrical apparatus, microscopes, and accessories.

## WANT, SALE, AND EXCHANGE NOTICES.

[These notices will be given six insertions in this column at 25 cents per line or fraction thereof.]

WANTED.—Diatom material from America, Australia, and Asia in exchange for fossil and recent material from Denmark.

CHR. MICHELSEN, 33 Nedergade, Odense, Denmark.

FOR EXCHANGE.—Slides of diatoms from peat bogs in Boston, Mass.

F. F. FORBES, Brookline, Mass.

WANTED TO PURCHASE.—Histological slides from normal tissues of mammals, prepared with a view to show the size of the "cells," in cases where the age of the animal-subject is definitely known, as bearing on the question of a supposed diminution in the size of cells in aging organisms, corresponding to a similar decrease, reported by Balbiani and Maupas in aged unicellular life. Address,  
C. A. STEPHENS' LABORATORY, Norway Lake, Maine.

TO MICROSCOPISTS.—After July 1 the price of my well-known slides will be the uniform one of 50c. each, \$5.00 per dozen. Send 2c. stamp for catalogue and 50c. for slide of Podura scales, test, or other diatoms, or of miscellaneous objects. Thum's "Oh, My!" slides of arranged diatoms, gorgeous butterfly scales, etc., at lowest rates.

M. A. BOOTH, F. R. M. S., Longmeadow, Mass.

FOR SALE.—Spencer's 1-in. 40° objective; first-class series; new; and Spencer's  $\frac{1}{10}$ -in. 113° B. A. homo. 1mm. Professional series; has been used, but is in perfect order. Reason for selling, bad health and failing eyesight.

THOS. H. URQUART, M. D., Hastings, Neb.

WANTED.—Vol. VII, No. 2 (Feb., 1886), of American Monthly Microscopical Journal.

A. G. YOUNG, State House, Augusta, Me.

FOR EXCHANGE.—Well-mounted slides. Mostly histological objects and diatoms. Lists furnished.

H. W. WESTOVER, M. D., St. Joseph, Mo.

WANTED.—A Powell & Leland grand stand. Address, stating price and condition,  
G. S. WOOLMAN, 116 Fulton St., N. Y.

WANTED.—To buy a second-hand Microscope. Must be in perfect order and a bargain.  
R. S. W., Box 630, Washington, D. C.

SLIDES FOR EXCHANGE.—Very nice sections of silicified wood from Colorado, showing cell markings similar to those of the coniferae.

C. W. SMILEY, Washington, D. C.

FOR SALE.—Type plates of Diatoms. 50 species, \$3.00; 100 species, \$6.00. Mounts of single species from 40 cents up. Send 40 cents for specimen. I have also some choice spread slides for 40 cents each; \$4.00 per doz. Diatoms mounted to order, and all work furnished promptly. Catalogues on application.

D. B. WARD, M. D., Poughkeepsie, N. Y.

WANTED.—A Bulloch Professional Stand. Address, stating price,—

HENRY C. WELLS, 151 Broadway, New York City.

FOR EXCHANGE.—Slides of diatoms for other mounts or diatomaceous material.

F. F. FORBES, Brookline, Mass.

FOR EXCHANGE.—First-class "Edison's Electric Reduplicating Pen," cost \$35. Want any Microscopical accessories or slides not already in my cabinet. Address—

O. P. PHILLIPS, Wellington, Kans.

WANTED.—Barbadoes earth in quantity. Good mounts in exchange.

FRED'K B. CARTER, 61 Church St., Montclair, N. J.

WANTED.—To buy a second-hand Microscope. I prefer the Binocular, late style; must be in perfect order and a bargain.

R. G. W. Jewell, Box 56, Summit, Miss.

FOR SALE.—1 No. 546 Universal stand and accessories. 1  $\frac{1}{10}$  and 1  $\frac{1}{12}$  new Spencer H. I objectives. 1 Surveyors' Solar compass. 1 pocket Aneroid Barometer—for cash. Photo apparatus, or Projection Lantern.

W. N. SHERMAN, M. D., Merced, Cal.

NOTICE.—I have undertaken with the approval of Professor Gage to prepare an exhibition of the Crustacean Parasites of North American fishes as a part of the practical work of the American Microscopical Society at Chicago in 1893. In order that the display may be as complete as possible I respectfully ask members of the American Society and others to send me examples of any species that they may be able to spare for the purpose. The fullest data are desired. I would like to correspond with any one having books, pamphlets, or specimens of the sort to dispose of. D. S. KELLICOTT, Columbus, Ohio.



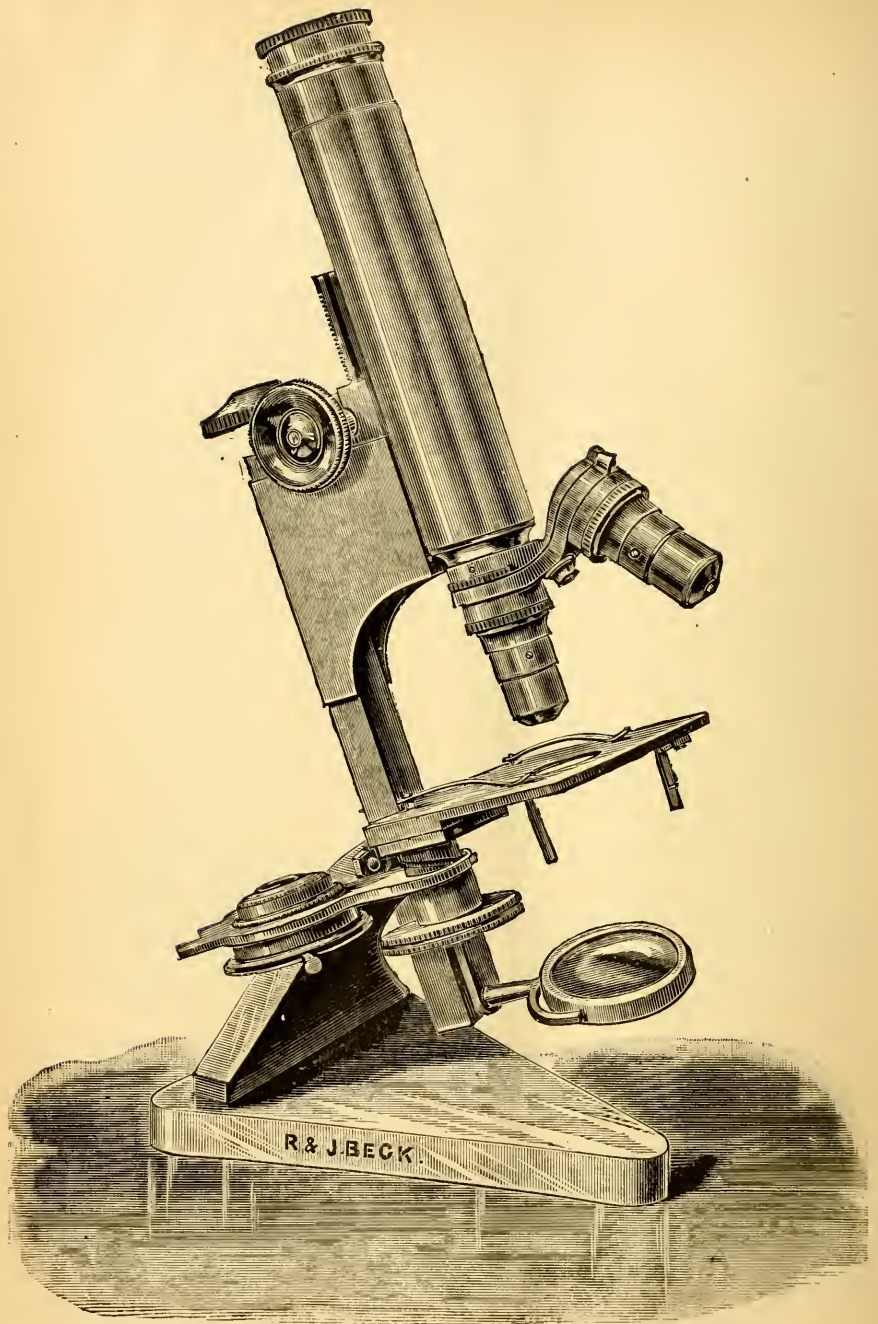

BECK'S NEW BACTERIOLOGICAL STAR MICROSCOPE.



# THE AMERICAN MONTHLY MICROSCOPICAL JOURNAL.

VOL. XIII.

APRIL, 1892.

No. 4.

## CONTENTS.

<p>The Abbe Illuminator or Condenser (Illustrated).—GAGE - 81</p> <p>Acknowledgment - - - - - 86</p> <p>Practical Studies in Biology.—I. The Potato.—OSBORN - - - - 87</p> <p>Use of the Microscope in Pharmacy.—WHELPLEY - - - - 89</p> <p>An All-around Microscope (Illustrated).—FORBES - - - - 91</p> <p>Magnifying Power of Objectives.—TOLMAN - - - - - 93</p> <p>A New Frame for the Pocket Microscope (Illustrated).—SAYRE. 95</p> <p>EDITORIAL - - - - - 96</p> <p>MICROSCOPICAL APPARATUS.— New Objectives. The Bacteriological Star Microscope - - 98</p> <p>MICROSCOPICAL MANIPULATION.— —A Paper for Cleaning the</p>	<p>Lenses of Objectives and Oculars. Glue for Labels. Use of Hydroxylamine - - - - - 99</p> <p>BIOLOGICAL NOTES.—Senega. Scarlet Clover. A Circular Growth of Fungus. Attachment of Vorticellæ - - - - 101</p> <p>BACTERIOLOGY.—A Bacteriological Examination of the Boston Milk Supply. A New Bacterium. Bacteria in Street-dust. Sewage - - - - - 102</p> <p>MICROSCOPICAL NEWS.—Death of L. D. McIntosh. White's Objects - - - - - 103</p> <p>CORRESPONDENCE.—Spencer &amp; Smith's Aplanatic Eye-Piece. 103</p> <p>MICROSCOPICAL SOCIETIES.— San Francisco. St. Louis. 104</p>
------------------------------------------------------------------------------------------------------------------------------------------------------------------------------------------------------------------------------------------------------------------------------------------------------------------------------------------------------------------------------------------------------------------------------------------------------------------------------------------------------------------------------------------------------------------------------------------------------------------------------------------------	--------------------------------------------------------------------------------------------------------------------------------------------------------------------------------------------------------------------------------------------------------------------------------------------------------------------------------------------------------------------------------------------------------------------------------------------------------------------------------------------------------------------------------------------------------------------------------------------

### The Abbe Illuminator or Condenser.

BY PROF. S. H. GAGE,

ITHACA, N. Y.

[From The Microscope and Histology.]

For all powers, but especially for high-power objectives, a condenser or illuminator is of great advantage. The one most generally useful was designed by Abbe. It consists of two or three very large lenses which are placed in some form of mounting beneath the stage. It serves to concentrate a very wide pencil of light from the mirror upon the object. For the best work in modern histology the Abbe illuminator is almost as indispensable as the homogeneous immersion objectives.

**Centring and Arrangement of the Illuminator.**—The proper position of the illuminator for high objectives is one in

which the beam of light traversing it is brought to a focus on the object. If parallel rays are reflected from the plane mirror to it, they will be focussed only a few millimeters above the upper lens of the illuminator; consequently the illuminator should be about on the level of the top of the stage, and therefore almost in contact with the lower surface of the slide. For some purposes, when it is desirable to avoid the loss of light by reflection or refraction, a drop of water or homogeneous immersion fluid is put between the slide and condenser, forming the so-called immersion illuminator. This is necessary only with objectives of high power and large aperture or for dark-ground illumination.

**Centring the Illuminator.**—The illuminator should be centred to the optic axis of the microscope, that is, the optic axis of the condenser and of the microscope should coincide. If one has a pin-hole diaphragm to put over the end of the condenser (fig. 20)—that is a diaphragm with a small central hole—the central opening should appear to be in the middle of the field of the microscope. If it does not, the condenser should be moved from side to side by loosening the centring screws until it is in the centre of the field. In case no pin-hole diaphragm accompanies the condenser, one may put a very small drop of ink, as from a pen-point, on the centre of the upper lens and look at it with the microscope to see if it is in the centre of the field. If it is not, the condenser should be adjusted until it is. The microscope and illuminator axes may not be entirely coincident even when the centre of the upper lens appears in the centre of the field, as there may be some lateral tilting of the condenser, but the above is the best the ordinary worker can do, and unless the mechanical arrangements of the illuminator are very deficient, it will be very nearly if not absolutely centred.

**Mirror and Light for the Abbe Illuminator.**—It is best to use daylight for this as for all other means of illumination. The rays of daylight are practically parallel, and it is best, therefore, to employ the plane mirror for all but the lowest powers. If low powers are used the whole field might not be illuminated with the plane mirror and the condenser close to the object; furthermore, the image of the window-frame, objects outside the building, as trees, etc., would appear with unpleasant distinctness in the field of the microscope. To overcome these defects, one can lower the condenser and thus light the object with a diverging cone of light, or use the concave mirror and attain the same end when the condenser is close to the object (fig. 20).

**Lamp-light.**—If one must use lamp-light, it is recommended that a large condensing lens be placed in such a position between the light and the mirror that a picture of the lamp flame is thrown upon the mirror. If one does not have a condensing lens the concave mirror may be used to render the rays less divergent. It may be necessary to lower the illuminator somewhat in order to illuminate the object in its focus.

## EXPERIMENTS.

**Abbe Illuminator, Axial and Oblique Light.**—Use a diaphragm a little larger than the front lens of the  $\frac{1}{8}$  (3 mm.) or No. 7 objective, have the illuminator on the level or nearly on the level of the upper surface of the stage, and use the plane mirror. Be sure that the diaphragm carrier is in the notch indicating that it is central in position. Use the *Pleurosigma* as object. Study carefully the appearance of the diatom with this central light,

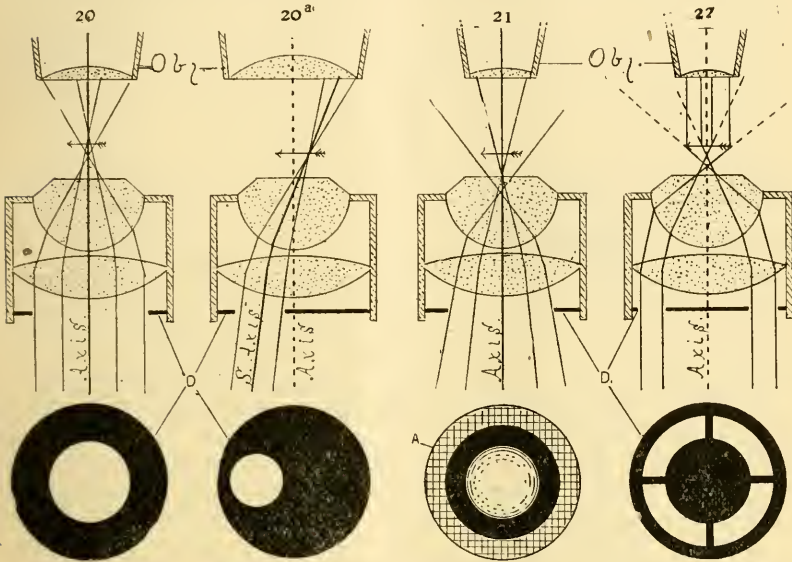

## EXPLANATION OF PLATE I.

Fig. 20, 20<sup>a</sup>, 21, and 22. Sectional views of the Abbe Illuminator of 1.20 N. A., showing various methods of illumination. Fig. 20, axial light with parallel rays. Fig. 20<sup>a</sup>, oblique light. Fig. 21, axial light with converging beam. Fig. 22, dark-ground illumination with a central stop diaphragm.

*Axis.* The optic axis of the illuminator and of the microscope. The illuminator is centered, that is its optic axis is a prolongation of the optic axis of the microscope.

*S. Axis.* Secondary axis. In oblique light the central ray passes along a secondary axis

of the illuminator, and is therefore oblique to the principal axis.

*A,* Fig. 21 represents the upper part of the illuminator.

*D D.* *Diaphragms.* These are placed in sectional and in face views. The diaphragm is placed between the mirror and the illuminator. In Fig. 20 the opening is eccentric for oblique light, and in Fig. 22 the opening is a narrow band, the central part being stopped out, and thus giving rise to dark-ground illumination.

*Obj. Obj.* The front of the objective.

then make the diaphragm eccentric so as to light with oblique light. The differences in appearance will probably be even more striking than with the mirror alone.

**Lateral Swaying of the Image.**—Frequently in studying an object, especially with a high power, it will appear to sway from side to side in focussing up or down. A glass stage micrometer or fly's wing is an excellent object. Make the light central or

axial and focus up and down and notice that the lines simply disappear or grow dim. Now make the light oblique either by making the diaphragm opening eccentric or if simply a mirror is used by swinging the mirror sidewise. On focussing up and down, the lines will sway from side to side. What is the direction of apparent movement in focussing down with reference to the illuminating ray? What in focussing up? If one understands this experiment it may some time save a great deal of confusion.

**Dark-Ground Illumination.**—When an object is lighted with rays of a greater obliquity than can get into the front-lens of the objective, the field will appear dark (fig. 22). If now the object is composed of fine particles, or is semi-transparent, it will refract or reflect the light which meets it in such a way that a part of the very oblique rays will pass into the objective, hence, as light reaches the objective only from the object, all the surrounding field will be dark, and the object will appear like a self-luminous one on a dark back-ground. This form of illumination is only successful with low powers and objectives of small aperture. It is well to make the illuminator immersion for this experiment.

**With the Abbe Illuminator.**—Have the illuminator so that the light would be focussed on the object and use a diaphragm with the slit opening; employ the three-fourths objective. For object place a drop of a 10 per cent. solution of salicylic acid in alcohol on the middle of a slide and allow it to dry and crystallize. The crystals will appear brilliantly lighted on a dark back-ground. Put in an ordinary diaphragm and make the light oblique by making the diaphragm eccentric. The same specimen may also be tried with a mirror and oblique light. In order to appreciate the difference between this dark-ground and ordinary transmitted light illumination, use an ordinary diaphragm and observe the crystals.

A very striking and instructive experiment may be made by adding a very small drop of the solution to the dried preparation, putting it under the microscope very quickly, lighting for dark-ground illumination, and then watching the crystallization.

#### HOMOGENEOUS IMMERSION OBJECTIVES: EXPERIMENTS.

These are objectives in which a liquid of the same refractive index as the front-lens of the objective is placed between the front lens and the cover-glass.

Put a 2 mm. ( $\frac{1}{16}$ th in.) homogeneous immersion objective in position, employ an Abbe illuminator.

**Refraction Images.**—Use some histological specimen like a muscular fibre as object, make the diaphragm opening only slightly larger than the front lens, add a drop of the homogeneous immersion liquid. The object will be clearly seen in all its details by the unequal refraction of the light traversing it. The difference in color between it and the surrounding medium will also increase the sharpness of the outline. If an air-bubble preparation were used, one would get pure refraction images.

For Color Images.—Use some stained microbes, as *Bacillus tuberculosis* for object. Put a drop of the immersion liquid on

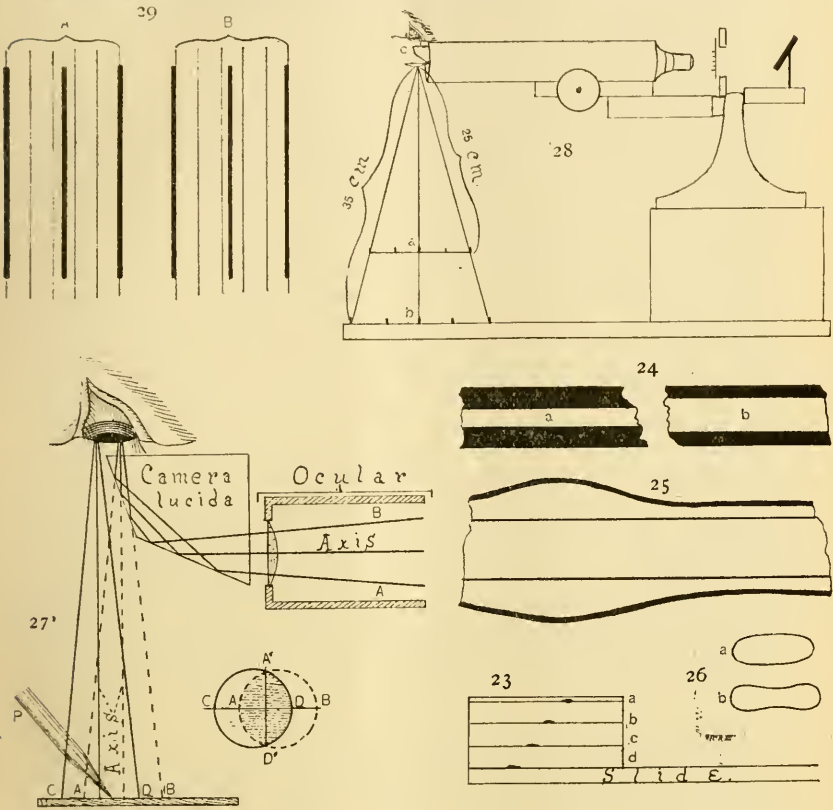

EXPLANATION OF PLATE II.

Fig. 23. Showing the method of mounting letters in stairs to show the order of coming into focus.

a, b, c, d. The various letters indicated by the oblique row of black marks in the sectional view.

Slide. The glass slide on which the letters are mounted.

Fig. 24. Glass rod showing the appearance in air (a), and in 50 per cent. glycerine (b).

Fig. 25. Glass rod coated with collodion to show double contour. At the left the collodion is represented as collecting in a drop.

Fig. 26. Mammalian blood-corpuscles on edge to show a surface view (a) and an optical section (b).

Fig. 27. Wollaston's Camera Lucida, showing the rays from the microscope and from the drawing surface, and the position of the pupil of the eye.

Axis, Axis. Axial rays from the microscope and from the drawing surface.

Camera lucida. A section of the quadrangular prism showing the course of the rays in the prism from the microscope to the eye. As the rays are twice reflected, they have the same relation on entering the eye that they would have by looking directly into the ocular.

A B. The lateral rays from the microscope and their projection on the drawing surface.

C D. Rays from the drawing surface to the eye.

A D, A' D'. Overlapping portion of the two fields, where both the microscopic image and the drawing surface, pencil, etc., may both be seen. It is represented by the shaded part in the overlapping circles at the right.

Ocular. The ocular of the microscope.

Fig. 28. Figure showing the position of the microscope, the camera lucida, and the eye, and the different sizes of the image depending

upon the distance at which it is projected from the eye. (a) The size at 25 cm.; (b) at 35 cm.

Fig. 29. Figure showing the appearance of the lines of the stage micrometer (the coarse lines) and of the ocular micrometer when using a high objective.

A. One method of measuring the spaces by

putting the ocular micrometer line opposite the centre of the stage micrometer line.

B. Method of measuring the space of the stage micrometer by putting one line of the ocular micrometer at the *inside* and one at the *outside* of the lines of the stage micrometer.

the cover-glass of the front lens of the homogeneous objective. Remove the diaphragms from the illuminator or use a very large opening. Focus the objective down so that the immersion fluid is in contact with both the front lens and the cover-glass, then with the fine adjustment get the microbes in focus. They will stand out as colored rods on a bright field.

**Shading the Object.**—To get the clearest image of an object no light should reach the eye except from the object. A handkerchief or a dark cloth wound around the objective will serve the purpose. Often the proper effect may be obtained by simply shading the top of the stage with the hand or with a piece of bristol board. Unless one has a very favorable light the shading of the object is of the greatest advantage, especially with homogeneous immersion objectives.

**Cleaning Homogeneous Objectives.**—After one is through with a homogeneous objective, it should be carefully cleaned as follows: Wipe off the homogeneous liquid with a piece of the Japanese paper, then if the liquid is cedar oil, wet one corner of a fresh piece in benzine and wipe the front lens with it. Immediately afterward wipe with a dry part of the paper. The cover-glass of the preparation can be cleaned in the same way. If the homogeneous liquid is a glycerine mixture proceed as above, but use water instead of benzine to remove the last traces of glycerine.

**Acknowledgment.**—To Dr. F. A. Rogers, Brewster, Mass., for a remarkable slide, it being nothing less than a longitudinal section of a human fœtus of eight weeks. The specimen was stained in bulk by borax-carmines, embedded in paraffine, sectioned on a Bausch & Lomb Student microtome to 1-2000 inch, fixed on the slide by an original and special method, stained as a contrast with sulphindigotate of soda, and mounted in balsam, using King's cement for ringing. To cut so large an object demands considerable care and skill, and the entire preparation is laborious and time consuming, but the result is worthy of attentive study. Dr. Rogers has also kindly sent a section of the hand of the same fœtus, showing the developing muscle and bone. These preparations are the finest of the kind that we have ever seen.

—o—

**Liquid Glue.**—Soak glue in water, then melt it at moderate heat, add vinegar until a thick fluid when cold. A small quantity of acetic or of nitric acid will preserve the fluidity at all ordinary temperatures.

**Practical Studies in Biology.—I. The Potato.**

BY H. L. OSBORN,

HAMLINE, MINN.

If the reader will obtain a fair, smooth, regularly-formed potato and, after washing its surface thoroughly, examine it carefully, he will be in possession of a very interesting biological specimen. The surface examination will show that, however broad or short or irregular a potato may be, it nevertheless has two ends. At one of these he will find a scar, or, perhaps, a piece of stringy matter which held the potato to the plant from which it grew; at the other end, a spot known in popular diction as an "eye," surrounded by other eyes. The smaller potatoes are rather more likely to have these two points at ends of an elongate body than the larger and less symmetrical ones. The surface examination shows more than this; it shows a thin "peel" or "skin," and at certain regular intervals "eyes." If one now takes a lead pencil and beginning at the bottom or remains of the stem shall trace a line from the lowest eye to the one next above it, going from the right about one-third of the way around to the second eye, and then going a third further to the third eye, and so on, he will find such a line will wind around and around the potato in the form of a spiral, which will meet every eye in succession at regular intervals, and finally terminate on the summit in the apical "eye." In the potato from which this study was made the eyes were numbered in succession from the lowest one, and the full number was 17. The eyes are now seen to be so placed (see figure in the continuation of this paper) that the spiral makes two turns before a second eye is reached, which is directly over a given one, thus four eyes will invariably be passed over before this eye is reached. Thus the sixth eye is over the first, the seventh over the second, the thirteenth over the eighth and the third. The eyes thus in line are: 1-6-11-16; 2-7-12-17; 3-8-13-18; 4-9-14; 5-10-15. The fact that the eyes are thus in line is very significant, and must obviously be the consequence not of any mere chance and unregulated occurrence on their part, but of the operation of some law inherent in the nature of the potato, especially since it is constant for all specimens, and where departed from is obviously due to irregular shape of the potato. It would plainly be no more reasonable to expect a potato which was bulged out of all shape to exhibit plainly the symmetry of body natural to potato than to conclude that mankind has but a single eye because we find a few blind men so deformed.

While the numbers which indicate the arrangement of the buds are constant for all specimens, namely, 5 buds in two turns of the stem, so that buds 1, 6, and 11 are in line, etc., it is a very singular fact that in some cases the line connecting them will pass from right to left and in other cases from left to right; that is to say, some specimens are right-handed, and others are left-handed.

If now, having examined the surface of the potato and learned that it has a base and apex, a thin skin and eyes, the relative positions of which are governed by a very definite and simple law, we cut the potato into halves by a slice, passing through the base and apex and through as many eyes as possible, we can learn still more about it. It is quite watery, as shown by the fluid which collects upon the surface cut by the knife. With a dry cloth, dry the surface. It will then present a granular appearance of the well-known whitish color, and a uniform texture throughout, up to the very narrow edge of the skin. A closer examination will, however, show a wavy line, imperfectly parallel with the skin, but perhaps an eighth of an inch below it; the line is seen to come to the surface at the eyes, but to be as described in all other locations. A cross section of the potato through one eye will present the same circular ring of substance parallel with the surface, except at the eyes.

The rough study of the potato can easily be made to yield a few more facts which we must take into account before we attempt to interpret the potato in biologic language. If we place a potato in moist and warm sand, sand which we have first carefully examined and proven to contain absolutely no organic matter of any kind, and keep it warm for a few days, we shall see that the eyes are the evident seats of activity, for they begin to enlarge. Later, a stem bearing leaves emerges from each eye, and these leaves are the precursors of subsequent ones on a further elongation of the same stem. The stems thus elongate all in the direction of the apex of the potato. If it was planted apex upward, they rise above the sand and the leaves become green. A removal and examination of the potato shows that the growth has been attended with decay of the substance of the potato, which we may safely infer, since the sand contains no organic substance, has gone into the construction of the growing stems and leaves.

The facts now acquire significance; the eyes are buds, the potato then a bud-bearing portion of the plant or a stem (an underground stem), and one considerably modified in shape; it is connected below with the plant and bears a terminal bud at its tip, and the eyes are lateral buds, the skin is dark, and the circular layer parallel with it is comparable with the woody zone of ordinary stems, while the bulk of the potato is thus a pith. If we were to imagine a stem, as of elder, vastly distended by growth of pith at its tip, nearly destitute of wood because living underground where it did not require support, we should have such a growth as that of the potato. If the potato be such a modified stem, its cell-structure and life ought to help to make the case still more clear. Studies bearing on this will follow in a succeeding chapter.

*(To be continued.)*



## Use of the Microscope in Pharmacy.

By H. M. WHELPLEY, M. D.,

ST. LOUIS, MO.

[From a paper read at the A. S. M., 1891.]

[Continued from page 50.]

2. **Use of the Compound Microscope.**—*a.* The study of vegetable histology is of much importance to the educated pharmacist, as animal histology is to the qualified physician. While work in vegetable histology does not require the use of an instrument with as high powers or present as many difficulties as are found in animal histology, still the microscope is just as essential in this line of investigation as in the one followed by physicians. The different vegetable tissues are as readily recognized as bone and muscle. A pharmacist can as easily distinguish a section of wood from a section of bark as an animal histologist can tell a section of bone from a section of epidermis. The arrangement of the various tissues in corresponding organs of different plants are quite characteristic; thus it is that one who is versed in the work can distinguish a transverse section of dandelion root from a similar section of chickory root.

This is simply one example of how the microscope will enable the educated pharmacist to identify a genuine drug or detect an adulteration.

*b.* The United States Pharmacopœia, the dispensatories, which are commentaries upon the Pharmacopœia, and all works on materia medica for pharmacists, recognize the importance of studying the microscopical appearance of transverse sections of vegetable drugs. While the Pharmacopœia is not an illustrated work, it gives quite explicit descriptions of the appearance of drugs as seen under the microscope. In the commentaries on the Pharmacopœia and the works on materia medica, we find illustrations of the drugs as seen under the microscope. The study enables the pharmacist to identify drugs, tell the quality, detect substitutions, adulterations, sophistications, and admixtures.

*c.* The study of the microscopical appearance of powdered drugs has not been carried to that degree of perfection which has been reached in vegetable histology; however, the field is an inviting one, and it is here that the pharmaceutical microscopists of the future will be able to do the most valuable work. Some idea of what can be done is shown by the work that the Department of Agriculture of the Government is doing in the examination of spices. See "Bulletin No. 13" of this Department.

Many of the histological elements of plants are such that they are readily recognized, even in the mutilated condition found in powders. It is often possible to identify cells from pith and other characteristic tissues, like the bast in cinchona, the stone of cinnamon, and the pitted ducts of red cedar. I remember an instance where a sample of powdered red pepper was simply fine red cedar

sawdust flavored with the oleroesin of pepper. A glance at the mixture under the microscope revealed its true nature. In coarse powders it is sometimes possible to recognize the stomata of leaves.

*d.* Pharmacognacy, or the recognition of drugs, is studied by aid of a system based upon the physical characteristic of the substances. As an example, we study the structure and characteristics of a leaf, which is one of the subdivisions of that great class of drugs derived from the vegetable kingdom. Leaves are again subdivided into two kinds, the herbaceous and coriaceous. These two classes are readily distinguished from each other by an examination without the aid of the microscope. However, the case differs when we come to the study of several other subdivisions of vegetable drugs. For instance, we take the roots, which is a subdivision corresponding to the leaves. The roots are divided into two similar subdivisions, known as the mono-cotyledonous and the di-cotyledonous. It is by means of examining a transverse section of these roots under the microscope that the pharmacist determines to which subdivision they belong. The di-cotyledonous are again subdivided into woody, with thick bark; woody, with thin bark and fleshy roots. As is readily understood, this classification is based solely upon characteristics revealed by the microscope. To continue with the subdivision one step further, we have the woody roots with thick bark, divided into those with oil, resin, or latex ducts and those without oil, resin, or latex ducts.

The advantage of such a system of classification is an interesting subject, but does not directly concern us as microscopists. Its consideration usually occupies an entire lecture in the College of Pharmacy.

*e.* The use of the microscope in microchemistry is not advanced as far in pharmacy as the use of the instrument in vegetable histology. The principal reason for this is owing to the difficulty of studying crystallography. A few of the more common salts like the cinchona alkaloids have been studied and their microchemical appearance are figured in the dispensaries. I have no doubt that microchemistry applied to pharmacy will be greatly advanced by the active pharmacist of the future.

*f.* The introduction of the compound microscope in the examination of urine is by no means recent. The value of the instrument in this work is so thoroughly recognized that it does not admit of debate. The examination of urine as a part of a pharmacist's work is fast gaining a similar position.

*g.* In conclusion, there are many incidental uses for the compound microscope in a drug-store, such as the examination of the smaller insects which infest drugs, the study of moulds which are found in pharmaceutical preparations, and other uses which suggest themselves to pharmacists with an investigating turn of mind.

## An All-around Microscope.

By PROF. S. A. FORBES,

DIRECTOR ILLINOIS STATE LABORATORY OF NATURAL HISTORY, CHAMPAIGN, ILL.

My personal studies are of a kind to require a microscope which may be used (1) for the study of bacteria slides, (2) for the study of mounted slides of serial sections, (3) to search through and examine carefully collections of minute alcoholics in glass dishes, (4) to dissect animals under powers varying from twenty to two hundred diameters, and (5) to study pinned insects in all positions.

For the first purpose one must have a stand fitted to carry objectives of the highest power and the best illuminating apparatus; for the second, something in the nature of a mechanical stage is very desirable, but this must have a far wider sweep than the ordinary geared stage; for the third, one must be able to explore rapidly and with low power a large surface, moving back and forth along parallel lines as with a mechanical stage, but with much freer motion in all directions. The stage must also be without surface projections or attachments, which would be in the way of a glass dish of considerable size. The instrument must, further, stand erect, and yet must not be too high to work at sitting. It is a great advantage if both eyes may be used. Fourth, for dissection hand-rests must be provided, and the microscope must usually stand erect, and should be a binocular. Fifth, for entomological work a binocular is needed, with stage socket for insect forceps, and with a large central opening in the stage to allow the ready turning of the object without interference of the pin or danger of injury to the specimen. As this large opening will admit light beside the condenser in bacterial work, it must be fitted with an adapter with a smaller opening. In this work, also, the rectangular movement of a mechanical stage is a great convenience for bringing insects readily into the field.

As I accomplish all these purposes perfectly by a single microscope, it seems to me that this instrument must be adapted substantially to everything which the biologist is likely to want to do with a microscope, and that a description of it may interest many situated similarly to myself.

My starting point is a Zeiss stand, No. 1, with oculars 1 to 5 (No. 3 being divided for the insertion of a micrometer), and objectives ranging from  $A_3$  to an apochromatic 1-12, with the corresponding eye-pieces. For ordinary binocular work I have a Zeiss binocular eye-piece, which has the advantage over any other binocular arrangement that it does not so increase the height of the instrument as to make it inconvenient to use it with low powers while sitting.

The special feature of the instrument is the stage, which is the simplest form of a mechanical movement in two rectangular directions, adapted to the square stage of my instrument as illustrated by the engraving accompanying. The stage plate of the

microscope is altered only by a triangular groove along the whole length of the lateral margin, and by an enlargement of the central aperture. Into this a heavy diaphragm may be slipped with an opening of the usual size for the Abbe condenser.

The apparatus for mechanical movement is essentially the ordinary mechanical stage, but working directly by hand instead of by rack and pinion, the especial advantage being the free long movement thus permitted. It is in two parts. A rectangular frame (*a*) showing front margin, and (*g*) as seen from behind, the lateral bar of which is beveled to fit into the triangular groove in the side of the stage plate, in which it slides forward and backward; and a thin plate (*b* and *f*) longer than the preceding and a little narrower, its beveled edges sliding laterally in a V-shaped groove on the inner edges of the anterior and posterior bar of the

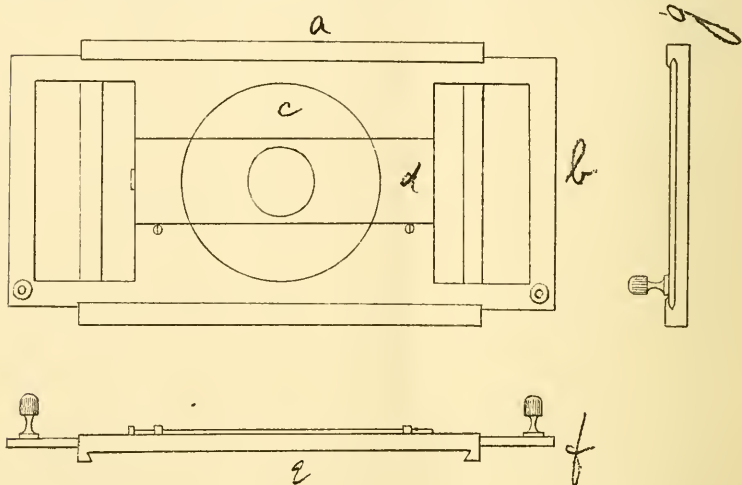

frame just mentioned. The projecting ends of this plate serve as hand-rests in dissecting. Three small screws are set in it as stops for the slide, and the knobs by which it is moved are bored in the centre as sockets for the stage forceps. Its central opening is of the same size as the larger opening in the stage-plate, and in this rests loosely a circular piece of glass (*c*) with a central opening (*d*), on which a dish may be set in examining small alcoholics. This apparatus, when well fitted and smoothly ground, works with a nicety and precision scarcely, if at all, inferior to that of the geared movement. An ordinary slide in position is shown at *e*.

This stage was made October, 1890, to my order and from my drawings, by the McIntosh Optical Company of Chicago, from whom I learn that it is now furnished with many of their own instruments, being adapted to the round stage-plate of their microscopes by placing under it a thin false stage-plate which bears beneath a socket that slips into the central opening of the stage.

## Magnifying Power of Objectives.

By H. L. TOLMAN,

CHICAGO, ILL.

The question of how much a given objective will magnify has always been an important but difficult one to answer, and every assistance offered toward solving it is worthy of attention. The distance of ten inches has been assumed as the proper interval between the objective and eye-piece, that being the average focal length of the normal eye, but where to measure from and to is not so easy to ascertain. Some opticians estimate from the end of the tube of the microscope, others from the outside of the back lens of the objective, others from a point midway between the different lenses of the objective, and still others from the front end of the latter. The difference between these two extremes is fully two inches, which may cause a difference of 20 per cent. in the results. Still others choose the point where parallel rays sent through the lens from the front would come to a focus, called the posterior principal focus, and one or two others, the posterior conjugate focus, still higher up the tube, a point where rays meet which emanate from another point in front of the objective, at a distance such that the size of the object and image are made equal. This is an easily established place, but a theoretical consideration of the optical principles involved shows that the only proper position from which to measure the tube length is from the posterior principal plane of the objective. In a simple lens this is easily ascertained, and in a very thin lens can be called the centre of the lens, but in a complex combination where the distance from the front of the front lens to the back of the back lens is sometimes two inches the exact point from which to estimate tube length becomes important. These principal planes in nearly all converging lenses are situated inside the objective at different distances from the centre of the combination, depending on the power of the lens and the way in which the corrections are made. In two-system objectives where the magnifying power is effected nearly equally by both systems, the principal planes are near the centre of the systems, while in some high-power objectives they may cross one another, the posterior plane being in front of the anterior. The principal foci anterior and posterior of a lens are also two important points to know, and when these four data are given they are all that are necessary for a discussion of the properties of a lens.

In the last journal of the *Royal Microscopical Society* under the head of Measurement of Lenses, Prof. S. P. Thompson has given a very exhaustive and able article on how to ascertain this point or plane from which the ten-inch tube length is to be measured. The instrument he uses is very complex and expensive, but the measurements can be made, except for high-power objectives, with a near approximation by anyone with a little mechan-

ical ingenuity. The principle of the mechanism is as follows: The objective to be tried is placed in a horizontal position, and some point on it, either the front end or some point on the side, is selected as a zero point for all measurements, a beam of parallel rays is sent through the lens from the back and the distance from the zero point to the focus  $F^1$  of these rays measured. The lens is reversed, and the focus  $F^2$  of the rays issuing at the back is measured from the zero point. Then two small glass micrometers with coarsely ruled lines are placed one in front of the other behind the lens, and moved by a screw until the image of one micrometer is seen in focus on the other, and the lines superimposed. The distances of these micrometers from the zero point is measured. We have now all the data for calculating the principal planes. It is a well-known optical principle that when an image of an object as shown on the screen is found to be the same size as the object, the distance between the two will be four times the focal length of the lens. In the present instance let  $F$  represent the anterior principal focus,  $F^2$  the posterior principal focus, obtained as above,  $S^1$  the anterior conjugate focus where one micrometer was placed, and  $S^2$  the posterior conjugate focus where the second micrometer was placed. Then the distance  $S^1 S^2$  is equal to four times the focal length, plus the distance between the two principal planes, because an objective is not equivalent to a bi-convex lens. To get the distance between the principal planes it is only necessary to subtract the distance  $S^1 S^2$  from twice the distance between the anterior and posterior principal foci. Now, to find when these planes are take the distance from the front focus or anterior principal focus to the micrometer, this is the true focus, and measure it backward toward or along the objective, it will fall in the tube, perhaps, a quarter of an inch from the front end; this is the first principal plane. Then measure from the back focus or posterior principal focus to the other micrometer, and that will be the distance to lay off on the tube from the back focus toward the front end of the objective; mark it on the tube, as it is the much desired posterior principal plane from which the ten inches is to be measured. To ascertain all this practically, perhaps, seems hard, but it is not very difficult to get very close measurements. A lower-power objective should be chosen and laid on a piece of cork along the edge of a board or the table. For micrometers take a stiff piece of writing paper and rule a series of lines a fiftieth of an inch apart, using a Brown & Sharp's steel rule as a guide; cut this paper across the lines so as to make two micrometers, thus securing uniformity in the lines, as if each micrometer was ruled separately the lines might not agree. Dip these papers in oil or hot paraffine to make them transparent, and mount in a slit in a piece of cork at such a height as to be able to see them through the objective. Take all measurements with a pair of callipers and lay them off on a rule. One ought to be able to get the principal planes within a fiftieth of an inch, and five times this would only make an error of one per cent. in the tube length.

## A New Frame for the Pocket Microscope.

BY PROF. L. E. SAYRE,

LAWRENCE, KANS.

A simple microscope, or pocket lens, as it is often and preferably called, is indispensable to every one who has a taste for the study of nature, not only because of its special quality of magnification as compared with the compound microscope, but because it is always ready for the examination of anything picked up by the roadside, in the fields, or in the woods. It has always seemed to me, however, that small and useful as it is, it does not entirely fill the requirements of the naturalist in his field-work, because it is not mounted in the most suitable frame for examining small flowers or parts of flowers. This is especially perceptible when one endeavors to hold in one hand a pocket lens and the object, while with the other hand he tries to dissect the object. The smaller the object the more difficult this becomes.

I have endeavored to overcome this by the device herewith presented. It consists of a long handle, at one end of which is hinged a stem which can move freely from the socket above as a knife-blade does in its handle. At the extremity of this stem there is inserted a ball-and-socket joint, which is surmounted by a second smaller stem, and this is surmounted by the microscope. It will be perceived from this construction that the magnifying lenses have full play, and can be placed in any position while it is being held firmly by the hand. Furthermore, while it is thus being held in any position desired, the thumb and index finger of the same hand are left almost perfectly free to hold any object, however minute. At the same time the other hand is left entirely free to operate with dissecting needles or with any instruments necessary for the purpose.

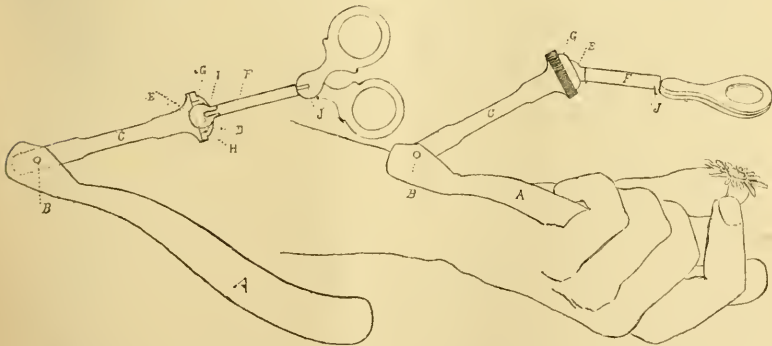

The claim for a patent is as follows: The combination in a simple dissecting microscope of a grooved hand-piece, *a*, with an arm *c*, connected with said hand-piece by a hinge joint, *b*, and

having at its other extremity a socket, *e*, and capable of movement in the same plane with said hand-piece, and the further combination of both said hand-piece *a* and arm *c* with a post, *f*, by means of a ball-and-socket joint formed by inserting the ball *i* into which post *f* is screwed into the socket *e* and adjustable by screw cap *g*, and the further combination of all these said three parts of the handle with the lens placed upon a needle point, *j*, the termination of a post, *f*, all substantially as set forth. An improved handle of a simple dissecting microscope, consisting of three parts, to wit: A grooved hand-piece, *a*, an arm *c*, and a post, *f*, terminating in a needle point, *j*, upon which the lens is placed, said parts being combined and united substantially as set forth.

### EDITORIAL.

*The Microscope*.—The periodical bearing this name was started eleven years ago (in April, 1881), at Ann Arbor, Mich., by Dr. and Mrs. C. H. Stowell, who entered into a vigorous competition with *The American Monthly Microscopical Journal*, which had been previously established by Prof. Romyn Hitchcock. The latter replied with scathing criticisms, some just and some apparently unjust. The most intense rivalry was created, and, although apparently losing money, for five years the contest went on, neither being willing to yield the field. But in August, 1886, the ill-health of Mrs. Stowell was announced, and *The Microscope* was transferred to Detroit, where a board of four editors assumed control. At about the same time, Prof. Hitchcock was invited by Prof. Todd to become a member of the eclipse party which was going to Japan, and he accepted. Both periodicals were now in new hands, and the era of hostility closed.

Had the competition been free from ill-feeling, it is likely that one of the two periodicals would have died out in a few months, for there never has been standing room for both, and the net profits of neither have ever been worth mentioning. At no time have the two combined ever had 3,000 subscribers, and yet either one could always have had a paying existence if it could have controlled the field.

It is an interesting incident that Dr. Stowell, since parting with *The Microscope*, has come to Washington to live, and the very month in which the magazine he founded has found its way to the same city (March, 1892), he has started a new medical journal called *The National Medical Review*, to which his old microscopical friends will doubtless want to subscribe, the price being only one dollar per annum. Mrs. Stowell is one of the microscopists in the Agricultural Department, and Prof. Hitchcock is also here, having just returned from a two-years' trip to China.

To run *The Microscope* as well as it has been run was found,



first by the Detroit people and next by the Trenton people, not to be a paying investment. Had they been willing to yield the highest place to the older journal, they might have occupied the amateur field, but this they would not do; nor would *The Journal* surrender the field which it had by the right of preoccupation. To Dr. Stokes and the writer is due the credit of bringing about, through friendly competition, a better state of affairs, and finally a discontinuance of wasteful competition.

It is greatly to his credit that he was willing to let *The Microscope* drop from the place it never ought to have tried to take, and to permit the writer to make such reorganization as in his judgment the circumstances demand.

*The Journal*, being the elder, has the right, outside of all personal considerations, to become the foremost microscopical periodical of America, and such we trust is its destiny. But the patronage is so small that a subscription price of two dollars is necessary, and all microscopists should frown down every attempt of ambitious persons to enter the field of competition until after there is room for a new periodical. Besides the few hundred Americans who want a high-grade microscopical periodical, there are about as many more who have no use for a strictly scientific journal, but who want strictly elementary matter. The advanced workers are not willing that their journal shall be made a vehicle for elementary matter, and the amateurs will not pay two or more dollars for a magazine combining everything. Hence consolidation seems impracticable. Were it attempted, a new dollar periodical would shortly spring up, first appealing to amateurs, but gradually working its way towards competition with the older journal. The history of the past twelve years would be repeated.

*The Microscope* will therefore take the elementary field as a dollar magazine, and be used as educative and preparatory to *The Journal*. It will presume its readers to be but little acquainted with the subject, and writers who can satisfy such people will be engaged. A large query department will be maintained, and the simplest questions as well as the abstruse will be answered. This department has already been tendered to a well-known writer, Dr. S. G. Shanks, of Albany, N. Y. We shall seek to supply every want of the beginner in microscopy, and try to induce many people to begin this fascinating occupation.

Perhaps some people have paid for *The Microscope* of 1892 in the desire to have more technical articles than will hereafter be found in it. If such persons desire to return the numbers which they have received and get their money back they can do so, or they can have the address changed to some other person to whom they wish to present the periodical, in which case we will notify the recipient to whom he is indebted for the present. We regret that this change of policy could not have taken place at the beginning of a volume, but this was unavoidable. Dr. Stokes had hoped, until within a few weeks, to go through the

year. Overwork, however, has compelled him to seek relief and recuperation in a trip 3,000 miles from home. On his return we hope and trust that he will be heard from often by those who have enjoyed his labors in the past.

We have explained the situation sufficiently to show why the size of the *Microscope* must be reduced to a paying basis. This will mean from 12 to 20 pages monthly, according to circumstances, and be influenced by the number of subscriptions which we can get, old and new. While the price will remain at one dollar, those who pay two dollars for *The Journal* will get the *Microscope* for one-half dollar additional. By scattering sample copies freely, it is hoped to attract to the subject many physicians and teachers who have heretofore let the subject go unnoticed.

Finally, who shall edit the *Microscope* on the basis now described? The matter is under consideration. But who do you prefer? We shall be pleased to receive a postal card from every one who expects to take a copy, announcing his or her ballot for editor. Who do you vote for? Vote early, and in this case there will be no harm if you vote often.

At last we may congratulate American microscopists that after eleven years of ruinous rivalry and migration, during which time both periodicals have been kept at starvation prices, the time has come for a union of effort, of desire, and of interests.

### MICROSCOPICAL APPARATUS.

**New Objectives.**—Among the new objectives recently made which are deserving of note are two, a 1-5th and 1-8th, both dry, of 150°. by Spencer & Smith, or as the firm used to be known, H. R. Spencer & Co., of Buffalo. These objectives are on a new formula, and for flatness of field, freedom from color, and sharp definition they rank very high. In fact, the robust images they give so much resemble in character those of the Zeiss apochromatics that they would be indistinguishable. They work easily through a No. 2 cover, and of course have cover correction. Perhaps I am rather an enthusiast in favor of Spencer's work, but without prejudice to any one else, I say, without hesitation, I never have seen better dry glasses than these. I believe there is none of the Jena glass used in them, but the chromatic observation is most exquisitely corrected, and it is gratifying to know such correction can be made without the necessity of using the as yet unproved kinds of glass.—*Henry L. Tolman.*

**The Bacteriological Star Microscope.**—This instrument (see frontispiece) is entirely of brass; it has a movable joint, rack and pinion and fine adjustment, society screw with a substage adjustment, which makes it one of the most efficient microscopes for the price that has ever been furnished to the student or prac-

tioner. In its optical performance it is said to be equal to the best instrument on the market. The Beck's, with their uniform work, which has been well-known for half a century, their large works in London having descended from father to son, have maintained an evenness of production which is remarkable. The same objectives and the same quality of eye-pieces are used on this stand that are furnished with the more expensive instruments, and added to the instrument is a fine Abbe condenser with iris diaphragm adjustment, which, by a simple device, can be accurately centred and raised and lowered by the spiral fine adjustment controlled by the large milled head. The adjustments are all quite simple.

There are several points in which this instrument is claimed to excel other low-priced microscopes: it is fitted with a substage to which can be applied all the substage fittings, such as polariscopes, spot lenses, Abbe condenser, dark well, hemispherical lens, Dr. Willit's prism, and many other substage adjustments. It has the society screw. It is finished with a dark lacquer to prevent the action of chemicals from destroying its good appearance.

The instrument can be used with the highest powers, 1-12 and 1-20th being easily focussed. With the use of the Abbe condenser it is adapted to the examination of bacteria. It has a swinging double mirror, and at the right side of the instrument is a large milled head, by the revolution of which the substage is raised and lowered for the most delicate focus of the light upon the object, and when not in use the entire substage can be thrown out of the focal axis.

The No. 115, Beck's New Bacteriological Star Microscope, with Abbe condenser and iris diaphragm, two eye-pieces,  $\frac{1}{2}$ -inch objective and 1-6-inch objective, in walnut case, sells for \$65.00. The same, but with 1-12-inch oil immersion objective instead of 1-6-inch, sells for \$90.00.

---

## MICROSCOPICAL MANIPULATION.

---

**Paper for Cleaning the Lenses of Objectives and Oculars.**—The so-called Japanese filter paper (the bibulous paper often used by dentists when filling teeth) is being used for cleaning the lenses of oculars and objectives. Whenever a piece is used once it is thrown away. It is more satisfactory than cloth or chamois, because dust and sand are not present, and from its bibulous character it is very efficient in removing liquid or semi-liquid substances.

Use it for removing immersion fluid from objectives, cloudiness or dirt from eye-pieces, glass slips, or thin glass. Water, glycerine, or other fluids can be removed. It is very cheap. It is put up

in packages of 500 sheets, 10 x 7 inches, at \$1.00, and 100 sheets, 10 x 7 inches, at 25c.

It is for sale by nearly all dealers in microscopes and materials. G. S. Woolman, 116 Fulton st., New York, is the one who has introduced these cheap packages.

**Glue for Labels.**—(1) Dissolve at a moderate heat 2 parts of white gelatine and 1 of rock candy in 3 of water.

Or (2) dissolve at moderate heat 9 oz. glue,  $4\frac{1}{2}$  oz. rock candy,  $1\frac{3}{4}$  oz. gum arabic in 1 part of rain or of distilled water.

**Use of Hydroxylamine.**—In preserving specimens for microscopic use, the following-named difficulty is frequently encountered. With death comes a muscular contraction of certain organs to such an extent as to obscure the points we desire to observe. In mounting various infusoria there is difficulty in fixing them in the best attitude. The preservative reagents cause rotifers and all kinds of molluscs to shrink.

The old method of procedure was to try to kill the specimen instantly catching it in a distended condition. But Dr. Bruno Hofer has proposed to paralyze the contractile organs and to then fix the paralyzed animal. After using with more or less satisfaction cocaine, antipyrine, chloral, and other alkaloids, he settled upon hydroxylamine as by far the most efficient. With it paralysis is secured before the protoplasm in the cells has swollen perceptibly.

The following directions are given for using hydroxylamine :

One per cent. of the crystals of the commercial hydrochlorate, which are usually impure, is dissolved in fresh water, and enough carbonate of soda added to render the solution neutral. This solution may be kept on hand in large quantities for use at any time. Distilled water must not be used in preparing it, but in the case of marine forms salt water must necessarily take the place of fresh. It is not advisable to eliminate the hydroxylamine from the hydrochlorate solution by adding an excess of carbonate of soda, as the liquid then obtained would over-excite the animal. After the animals have been paralyzed in the neutral hydrochlorate solution they are immediately covered with the fixing medium and thereby killed.

The number of fixing reagents that may be used is, of course, limited. For, hydroxylamine being a powerful reducing medium, all easily reducible agents, such as osmic acid, corrosive sublimate, chloride of gold, of platinum, etc., cannot be directly applied. The hydroxylamine must first be worked out with water. Alcohol, acetic, and picric acids, and mixtures of these two acids may be directly applied, and with these a good histological slide may always be obtained.

The strength of the solution depends, of course, on the nature of the animal to be mounted.

**BIOLOGICAL NOTES.**

**Senega.**—This snake root is collected in the country near the Lake of the Woods by squaws and children. In Marshall and Kittson counties a traveler recently saw a thousand pounds awaiting sale.

Prof. Sayre has examined it under the microscope and finds the wood cylindrical, whitish, ligneous, and occupying about  $\frac{1}{3}$  the dia. of the root. It contains  $3\frac{1}{2}$  per cent. of polygalic acid. See *Amer. Jour. Pharmacy*, March, 1892.

**Scarlet Clover.**—This clover, *Trifolium incarnatum*, has been introduced from Europe in Kent and Sussex counties, Delaware. It is attracting wide notice, so much so that Prof. A. T. Neale, director of the Experiment Station at Newark, Del., has just issued a most valuable bulletin containing 15 pages of interesting information. A copy can be secured by any person interested in the subject. It has been found that the scarlet clover acts as a weed eradicator, especially in the case of sheep sorrel. It proves an excellent food for honey-bees, and is very useful in orchards.

**Circular Growth of Fungus.**—On a recently mowed lawn of blue grass, one morning in July, there suddenly appeared a ring of grass affected with a fungus of a black color. The ring was about nine feet in diameter and the affected rim about eight inches wide. At a distance it looked as if some one had painted a ring on the grass with a brush dipped in tar. It could be plainly seen across the street a hundred feet away. The fungus occupied a circular rim which was almost perfect. A wahoo bush in the circle interrupted the fungus about four feet. On handling the grass the fingers were blackened as with soot. Each blade was dotted with black, globular dots. These globular objects, on being opened, were found filled with spores. Some of the grass was sent to the Smithsonian Institution, and there identified as *Physarum cinereum*, one of the Myxomycetes. Now, what caused this fungus to grow in a perfect circle? The lawn has been in grass for many years and no tree ever occupied its site, the ground being originally prairie. Many years ago, when an out-lot, the plat of ground was often occupied by a circus. No mowed hay had ever been stacked on this special patch of ground.—*H. M. Farr, M. D.*

**Attachment of Vorticellæ.**—A friend brought me some *Cyclops* which were utilized as an attachment for colonies of *Vorticellæ*. While the *Cyclops* remained quiet the *Vorticellæ* would extend themselves outward and move their cilia actively, but when the *Cyclops* began to stir, back they darted close to the body. No matter how suddenly the *Cyclops* darted forth, the *Vorticellæ* seemed to anticipate and be close to the body as soon as it began to move. I wish to ask if it is common for *Vorticellæ* to be attached to *Cyclops* and to other animals of rapid movements?—*H. M. Farr, M. D.*

## BACTERIOLOGY.

---

**A Bacteriological Examination of the Boston Milk Supply.**—Professors Sedgwick and Batchelder, of the Massachusetts Institute of Technology, have reported in the *Boston Medical and Surgical Journal* some results of their work.

They declare that the so-called "pure" milks, even when not tampered with, were found to swarm with millions of these microscopic vegetables to every teaspoonful, the effect of which always must be to produce sourness and chemical decomposition.

In milk as it came from the cow they could find no bacteria, though special means were necessary in order to prevent infection during the milking process. The silver catheter of veterinarians was used, it first having been sterilized by heat and brought to the stable in a plugged test tube. The receptacle also was sterilized. It was shown beyond a doubt that healthy cows give milk absolutely free from bacteria.

The trouble was found to arise from particles of dirt and filth getting into the pail during the milking process. Such pollution is proved to be general by the bacterial tests. Once introduced the bacteria multiply enormously, and souring follows early.

Milk drawn with great care but by hand was found to contain 530 bacteria per c.c. That drawn in the ordinary manner but by the average milkman contained 30,500 per c.c. Of that which had stood several hours, the average of 15 samples gave 69,143 per c.c. Of 57 samples taken from peddlers the average was 2,355,500 per c.c. Of 16 samples from grocers, who usually hold it on hand longer than the peddlers, the average was 4,577,000 per c.c. An extreme case of railroaded milk had in it 5,664,000 per c.c.

They speak in plain terms of the need of inspection to prevent pollution quite as much as to prevent adulteration. Improvement in milkmen and in receptacles is very urgent. That well people may consume large quantities of such milk without injury is admitted, but that infants and invalids suffer therefrom seems to be of little doubt. Thus, though indirectly, do we find again the microscope to be one of the civilizers of the age.

**A New Bacterium.**—L. Perdrix has separated from Paris water a bacillus, *B. amylozymicus*, which ferments starch with production of amyl alcohol. It is separated by culture in potato and finally on gelatine. It grows only in the absence of oxygen. Fuller description may be found in *Ann. Inst. Pasteur*, 1891, No. 5, and a translation in *Four. Chem. Soc.*, 1892, p. 90.

**Bacteria in Street-dust.**—Dust from the streets of Naples yielded 761,541,000 micro-organisms per gram of dust on the average. The filthiest street dust furnished 5,000 million per gram, many of which were pathogenic germs. The regions were proportionately unhealthy.

**Sewage.**—Sir Henry Roscoe has isolated 12 organisms from ordinary sewage. The relative power of the different organisms for determining the oxidation of organic matter was studied. *Proteus vulgaris* alone absorbed oxygen energetically. The Trans. Royal Society contains full details and photographs of the organisms.

### MICROSCOPICAL NEWS.

---

**Death of L. D. McIntosh.**—It is with deep sorrow that we have to announce the death of L. D. McIntosh, M. D., D. D. S., Vice-President of the McIntosh Battery & Optical Company, which occurred very suddenly on Tuesday, March 1, at De Funiak Springs, Florida, where he had gone to lecture before the Florida Chautauqua on Microscopy and kindred subjects.

**White's Objects.**—We have just received a fresh invoice from Europe containing nearly every number in the list.

### CORRESPONDENCE.

---

**Spencer & Smith's Aplanatic Eye-Piece.**—I have recently purchased from Spencer & Smith, of Buffalo, N. Y., a 1-inch positive eye-piece, which is so far superior to anything I have ever before used (and I have a large assortment) that I feel justified in calling the attention of microscopists to it. In common, I suppose, with a majority of workers, I, for a long period, paid no special attention to my eye-pieces, which, however, happened to be good ones, but centered my attention upon the objective and stand. I have long supposed that no available use could be made of any eye-piece for micrometric purposes except in a limited portion of the centre of the field, never exceeding one-half thereof.

With the eye-piece in question I find sensibly equal amplification and no distortion almost to the extreme edge of the field. In this respect it far surpasses the Ramsden and Huyghenian eye-pieces.

I find also that with it the definition, which I always test on a podura, is much improved, and that it is good almost to the extreme edge of the field, and this without any new adjustment of the focus. Altogether this eye-piece, which for want of a better name I shall call "Spencer & Smith's Aplanatic Eye-piece," is, in my judgment, a distinct advance over existing eye-pieces. I have ordered another one for my Zentmayer filar micrometer, and propose to use it hereafter in my micrometrical work in preference to those heretofore used.—*M. D. Ewell.*

CHICAGO, March 30, 1892.

Although I sent the usual dollar subscription in January, I am so much pleased with the new departure that I now make up the amount of the April price (\$1.50).—*H. S. Kelley.*

The first of April having passed, I suppose your price is now \$1.50, but I write to inquire whether you will still accept my dollar for 1892?—*G. W. F.*

I am glad to see that you propose to raise the price of the *Journal*. It is the right and proper step.—*J. Halle.*

### MICROSCOPICAL SOCIETIES.

SAN FRANCISCO, CAL., GEO. OTIS MITCHELL, *Sec'y.*

*March 2, 1892.*—Seventeen members and three visitors were present. President Breckenfeld expressed his thanks for the honor conferred upon him in the election to the office, and indulged in some pleasant and interesting references to his eight years' connection with the society.

The secretary reported the receipt of the periodicals subscribed for by the society, and of a pamphlet upon the *Precocious Segregation of the Sex Cells in the Micrometrus Aggregatus* from the author, Dr. Carl Eigenmann.

R. W. Hills was elected to regular membership, and D. C. Booth was proposed, and his nomination was ordered to take the regular course. G. O. Mitchell, for the Committee on the Work-room, reported what that committee had done in fitting up a dark room for photo-micrography and in furnishing abundant facilities for the members to work in preparing and mounting objects. He extended an invitation to all present to visit the room upon adjournment, when Mr. Reidy would be present to do the honors.

Judge Spencer, of San José, laid before the society a very interesting piece of apparatus, the Abbe binocular eye-piece, speaking at length of its many points of advantage over other means of producing the stereoscopic vision. Some discussion followed upon theoretical points concerning the principles involved. Judge Spencer kindly placed the apparatus at the disposal of the society for the closer examination of its claimed merits.

Mr. Breckenfeld read a paper upon "Some of the Common Forms of Fresh-Water Algæ."

### ST. LOUIS CLUB OF MICROSCOPISTS.

*Thursday March 4.*—Met at Dr. J. C. Falk's office, he being president. He described and illustrated the microscopical examination of urine, and enumerated other uses for the instrument when owned by a retail druggist. Thos. Knoeble, Dr. Whelpley, Otto Meyer, Wm. Ilhardt, Harry Starks, and Jos. Layat made remarks.





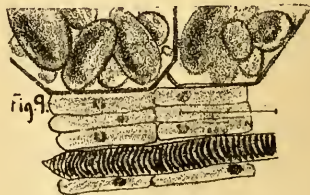
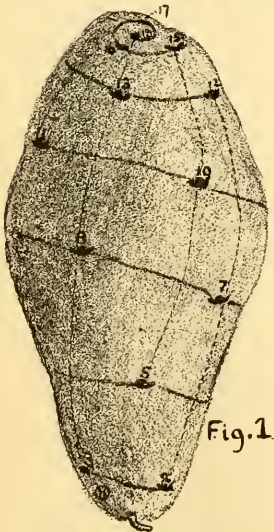
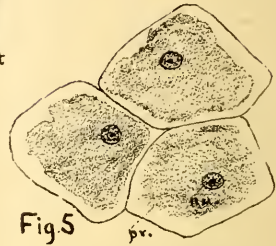
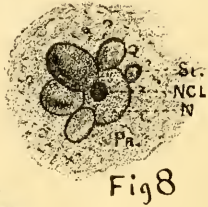
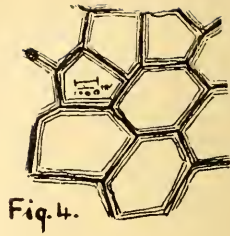
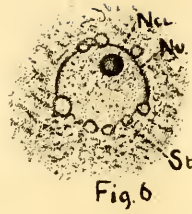
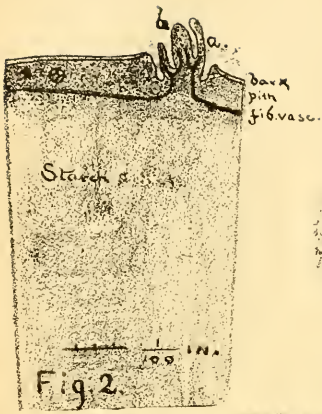

BIOLOGICAL STUDY OF THE POTATO.

# THE AMERICAN

## MONTHLY

# MICROSCOPICAL JOURNAL.

VOL. XIII.

MAY, 1892.

No. 5.

### CONTENTS.

<p>Practical Studies in Biology.—I.  The Potato.—OSBORN (Illustrated) - - - - - 105</p> <p>Radiolaria: Their Life-History and Their Classification.—  CARTER - - - - - 111</p> <p>How to Collect Desmids.—HASTINGS - - - - - 113</p> <p>On Imbedding Animal Tissues in Paraffine for Sectionizing.—  OSBORN - - - - - 116</p> <p>EDITORIAL.—Trip on a Cunard Steamship - - - - - 118</p> <p>MICROSCOPICAL APPARATUS.—  A Revolving Table - - - 120</p> <p>MICROSCOPICAL MANIPULATION.  Glycerine. Glycerine Jelly.  Dead Black. Smith's Method of Drawing - - - - - 120</p>	<p>BIOLOGICAL NOTES.—Fungus Study. Agassiz. Salmon and Sturgeon in Idaho. Cedar Trees and Apple Rust. Arbor Day. 121</p> <p>DIATOMS.—To Work the Diatomaceous Earth sent out by this JOURNAL. To Mount Diatoms. Hudson River Fiord - - - 122</p> <p>BACTERIOLOGY.—Pasteurized Milk. A Bacterial Disease of the Potato - - - - - 124</p> <p>RECREATIVE MICROSCOPY.—Microscopic Mounts of Minerals in Boxes. Lycopodium - - 125</p> <p>MICROSCOPICAL SOCIETIES.—St. Louis. Washington. Montreal. Omaha. Essex. Iron City. New Jersey. New York. 126</p> <p>NEW PUBLICATIONS.—Woolman. 128</p>
-----------------------------------------------------------------------------------------------------------------------------------------------------------------------------------------------------------------------------------------------------------------------------------------------------------------------------------------------------------------------------------------------------------------------------------------------------------------------------------------------------------------------------------------------------------------------------------------------------	---------------------------------------------------------------------------------------------------------------------------------------------------------------------------------------------------------------------------------------------------------------------------------------------------------------------------------------------------------------------------------------------------------------------------------------------------------------------------------------------------------------------------------------------------------------------------------------------

## Practical Studies in Biology.—I. The Potato.

By H. L. OSBORN,

HAMLINE, MINN.

[Continued from page 88.]

WITH FRONTISPIECE.

We have noticed that the potato is really a plant-stem, with pith and bark and buds, both lateral buds placed in a definite location in obedience to a fixed law of plant growth and a terminal bud. We are justified therefore, in spite of its unusual situation below ground where we commonly look to find roots, not stems, in comparing the tuber with other stems. Other examples of stems growing below the ground are not wanting; thus the peanut is a ripened fruit-pod which matures in the ground, and is demonstrable to be an underground stem; the onion is also a very short stem; when it is planted in the ground its terminal bud

develops, and its leaves furnish the food for a growth which is preparatory to the maturation of the seeds. The potato tuber shows a great uniformity of histological structure, there being many thousands of starch-filled pith-cells for every cell of any other kind, and it presents a case of the application of division of labor and the production of a large aggregate tolerably uniform in character. It will be well to begin a description with the epidermis or bark. This is to be studied by thin sections, cut parallel to the surface, supplemented by vertical sections. Figure 2 is a drawing, magnified about ten times, of a slice vertical to the surface and passing through a bud. The thin outer band of this section is the hypodermis or bark. The band parallel with this passing up into the bud is the bundle of fibro-vascular tissue which corresponds with the wood of stout woody stems, while the remainder is pith or parenchyma cells, full of starch grains. A surface view of the hypodermis, magnified 133 diameters, is shown in figure 4. It presents polygonal outlines, many of which are more or less perfect hexagons. These are the boundaries of the cells of the epidermis. A vertical section (fig. 3) shows at *e* the same cells in a plane at right angles to the first. They are broad flat plates, very thin walled, several rows deep. They do not contain any protoplasm, which, however, is present in the layers just beneath the bark from *d* to *e* in fig. 3. The bark upon the parts of plants which are in the air is commonly composed of broad and flat cells devoid of protoplasm, and with their outer walls very much thickened (to prevent evaporation) and (as explained by Bessey in his Botany, Advanced Course, pp. 93-94) generally only one cell-layer deep. In aquatic plants the thickening of the outer wall is not extensive, if present at all. The bark in the potato is not exposed to the drying influences of the air, being enveloped with moist earth, and hence we find no thickened cell-walls. Its cells as figured are only the shells of the living units which did their life-work in forming the protective brown and somewhat scaly envelope about the cells within and from which the protoplasm has departed. The brown color of the cell which gives the characteristic color to the potato peel is interesting. In sections the color shows not as any definite grains of pigmentary or coloring matter, but as a diffused yellowish tinge seen in all parts of the epidermal cell-wall.

This color is due to the presence of a very slight amount of the same substance which is present abundantly in the cells which form hard coverings like the hard bark of a tree or the shell of a nut, and it shows that the epidermal cells of the potato, when alive, secrete such matter as the epidermal cells of other plants often secrete upon a much larger scale. I do not think that this secretion can be said to be of any use to the potato. It is not extensive enough to perceptibly thicken the cell-walls, though it may be tougher and a better protection than ordinary cellulose would be. If it is not of any use its presence may be a case of persistence of the

bark-producing function in the epidermis, due to inheritance pointing backward to the time when the epidermis of this stem was an aerial organ of the plant.

The bud is also covered with epidermis, but the cells like all those of the bud are embryonic. They are small, more globular, and filled with protoplasm. They are alive and capable of growth and secretion, keeping pace with the general development of the bud. The bud shows hardly any cell differentiation at its outer parts, though the tissues of the potato are formed at its base, but the cells show subdivisions into terminal and lateral portions and leaves even in the most embryonic specimens. It would be very interesting to inquire into the state of the living protoplasm in the dormant bud. Only a little warmth and moisture applied during a few days are necessary to arouse the vitality of the protoplasm and cause the bud-cells to rapidly grow by division and acquire the various functions of new stems.

Directly below the epidermis there are flat cells, but much thicker than those of the outer skin. These cells are protoplasmic and alive. They can be readily seen in both vertical sections or horizontal sections. If these cells be treated with a dilute acid, as 1 per cent. hydrochloric or nitric acid, the protoplasm will be coagulated and shrunken, and then a thin layer of it which formerly fitted closely the cell-wall becomes visible (see fig. 5). The layer is called the *primordial utricle*. Its function is to secrete and shape the cell-wall. The primordial utricle in a living cell is so close to the cell-wall that in a living cell it can be seen only rarely, and only by the best trained observers. The central mass of protoplasm can be seen in the living cell (see fig. 3, *e*) with its nucleus and radial streams of protoplasm stretching between the centre and the primordial utricle. The protoplasm is thus insufficient to fill the cell: the spaces left are called vacuoles and contain watery fluid.

In embryonic cells which have not attained maturity of size and structure, the protoplasm fills the cell (see fig. 3, *d*); there are no vacuoles. It is in cells at the layer *e* of figure 3 that the starch is being formed. In all the other parts except just here, next the epidermis, the process has been completed. This makes it possible for the potato to constantly enlarge during its season of growth. The drawings in figures 6, 7, and 8 show portions of different cells very highly magnified. The protoplasm is shown surrounding the nucleus with its well marked nucleolus. Scattered about in the protoplasm, but chiefly in the immediate vicinity of the nucleus, can be seen numerous minute droplets of starch. They present the features of starchy degeneration, a state which sometimes happens as a pathologic change in animal protoplasm and which also closely resembles the mode of occurrence of fatty degeneration in the senile yeast-cell and in unhealthy animal cells. The droplets formed increase by addition of increments of starch until a number of very well-defined starch-bodies can be seen, usu-

ally around the nucleus, as shown in figure 8, *a*, camera-lucida drawing. The starch grains in later stages of the process become so numerous as to prevent vision of their relation to the protoplasm, but in deeper cells they can be seen in greater numbers, till finally they entirely fill the cell, apparently to the entire exclusion of the protoplasm.

There would seem to be no limit to the extent to which this secretion and deposit of starch and the growth and enlargement of the tubes can extend, but the growth is merely an indefinite continuation of the process just described.

The only remaining tissues of the potato are those of the fibro-vascular bundle, which is to be regarded as an aborted structure. Two kinds of cells are characteristic of the zone, parallel with the surface; the long cylindrical cells of figure 9 and the spiral cells, the side and one termination of which are shown in the figure. The function of support of the spiral cell is not its function here, for no support is required of a body in this position. If the yellow tinge in the epidermis be a dubious case of persistence through inheritance of a now not used character, the fibro-vascular tissue can be regarded, beyond question, as a vestigiary structure, pointing to a time when the stem was an aeriell organ in which the fibro-vascular tissue was needed for support; a case like the useless eyes of moles and the coalesced neck-vertebræ of cetaceous and a host of other inherited structures which imply ancestors in whom these organs were functional.

The buds are closer together at the apex of the stem and the embryonic tissue of each is portioned out to it in the terminal bud, which to the naked eye has others about it too close to be distinguished, and by the microscope is found to be making provision for still other ones. To each one of these is imparted a small portion of embryonic tissue, but this tissue is alike in all the buds.

As some perhaps look upon the potato, it appears to be a very admirable source of food for man, but it is hardly biological to attribute to the plant such exalted altruistic motives of disinterested generosity as it might imply if we should intimate that this is the end and aim of its existence. There is a class of mankind who appear to deem it proper, like Pope, to hold all nature to account for itself as useful to man, and such would doubtless say that the potato was created to be a food product. To the biologist's ways of thinking, this end of the potato's life is merely incidental. From its standpoint a very unhappy incident; the real end and aim of the potato's life is to propagate its kind, the storage of starch being a part of the plan.

The life of the tuber of the potato is part of the larger life of the entire plant. The history of the tuber is as follows: It starts from a bud on a preceding "seed-potato," of which and of whose predecessors it may be thought to form a part, but really it is (like cuttings or slips from any plant) the beginning of what we may call a new plant. The early growth of the

cells in the embryonic part of the bud requires food, to furnish which is the reason for the starch supply. But after a time the growing bud-tissue differentiates into stem and leaves and rootlets, and then it can begin to depend, as all green plants do, upon the sunlight and the water and gases of the air and soil, and with their help to construct its own substance. The starch of the potato tuber thus acquires a biological meaning. Its production and storage are perfectly analogous to the provision made in seeds. I have already referred to the case of the peanut, where we have also an underground structure stored abundantly with food for the undeveloped embryonic tissue, which is also part of the nut. The substance in many seeds is largely albuminous, as shown so abundantly in the pea and bean, also in the peanut, which is a close ally of the pea and bean.

Since the potato tuber and the pea or bean are thus comparable in two respects, both being the starting-point of new individual plants and both containing cells which secrete and amass large quantities of food to nourish the embryo plant until its vegetative organs are developed, a hasty conclusion might be made by some that the potato is a sort of seed. This conclusion would be found by the study of the anatomy of the entire plant to be true only in a very particular sense, and not as meant in ordinary terms. The seed is the product of a ripened flower, while the tuber is not. There is a very great difference in the powers of potato-seed and of the tuber-bud; the latter propagates its kind absolutely and without variation, while propagation from seeds is very likely to result in the appearance of varieties unlike the parent plant. We have in this case an example of the law that nature works very variously toward the same end, using the stem-bud in one case as the special organ of propagation and the seed in another, equipping either suitably for its purpose.

Finally, if we compare the potato with an animal, we find that the aggregate of its actions are anabolic, that is, they are constructive, so that as their result elements, or simple inorganic compounds, are laid hold upon and caused to combine to form higher and more complex organic compounds used in the plant's structure. In this it is unlike an animal, the aggregate of whose activities is katabolic, for it takes in highly complex chemicals (furnished from the plant's work) and gives out simpler ones. Associated with the difference is the further fact that the functions of motility and sensation, which are so characteristic of animals and are possible by reason of the constant katabolic character of its metabolisms, are unspecialized in the plant if not entirely absent, while the metabolic function is highly specialized and results in the production of anabolic products in the vast amount we see in the tuber.

We see then that the same forces are at work in the vegetable as in the animal body. The active agents of the tuber are protoplasmic cells, which work along lines determined by inheritance,

and manifest certain of the protoplasmic powers in so high a degree as to nearly exclude the others, but retaining the two most universal powers of protoplasm—metabolism and reproduction.

## EXPLANATION OF PLATE.

(All figures were drawn with the Camera Lucida.)

FIG. 1. Surface view of tuber, showing the law of position of the buds,  $\times \frac{2}{3}$  natural size.

FIG. 2. Vertical section of the stem through a bud, showing the bud with its terminal portion at *b*, and its leaves at *a*, with the thin layer of bark and the pith in which, parallel with the bark, lies the fibro-vascular layer.

FIG. 3. Vertical section of stem magnified 133 diameters, showing (1) the bark cells at *c* in rows, the edges of which produce the parallel lines seen in the surface view (fig. 4); (2) the living subdermal cells specialized as starch producers. The uppermost are full of protoplasm (at *d* in the figure); below them are cells containing large vacuoles and in which the starch grains are forming (cf. figs. 7, 8, 9). There are only a few rows of these before the

cells filled with starch are reached at *st* in the same figure.

FIG. 4. Surface view of the bark cells magnified 133 diameters.

FIG. 5. Flat view of cells immediately below the bark from the level marked *d* in fig. 3. After treatment with weak acid these cells, before irrigation of the acid, appeared to be absolutely empty.

FIGS. 6, 7, 8. Greatly enlarged views of nucleus and surrounding protoplasm from cells at level of *e* in fig. 3, showing the starch granules surrounded by the protoplasm in different stages of formation.

FIG. 9. Section magnified 240 diameters, showing the fibro-vascular bundle with its spiral cell and the cylindrical cells on either side.

**The Decolorization of Preparations Stained with Osmic Acid.**—The staining power of osmic acid is very great, especially over the fat cells, and even with a very dilute solution it is very easy to overstain. Peroxide of hydrogen in dilute alcoholic solution will, to a certain extent, remove the excess of staining matter. The proportion of commercial hydrogen peroxide is 1 part to 8 or 10 parts of alcohol, and 3 to 5 parts of distilled water. The bleaching fluid should be prepared only as needed.—*Pacific Record*.

**Shimer's New Mounting Medium.**—This is made of equal parts of Farrant's solution, glycerine, and glycerine jelly, the last being made of gelatine, 30 parts; water, 70 parts; glycerine, 100 parts; carbolic acid, 2 parts. Of this jelly, liquified by the aid of a water-bath, pour 1 fluid ounce into a 4-ounce glass-stoppered bottle; add an equal volume of the Farrant's medium and of glycerine. Agitate, thoroughly mix, and add a small lump of camphor. A little warming is necessary to make it fluid for use.—*Pacific Record*.

**Ink for Writing on Glass or Porcelain.**—The *Rundschau* (Prag.) gives the following: Dissolve in the water-bath 10 parts bleached shellac and 5 parts Venice turpentine in 15 parts of oil turpentine. Incorporate in the solution 5 parts of lamp-black. So-called diamond ink for writing on glass is a compound of fluoric acid and barium; the latter has no effect, it being simply a white powder to give body to the acid. The ink can be used with a rubber hand-stamp, and it should be allowed to remain fifteen minutes, when the barium will brush off, leaving the design on the glass.—*Nat. Drug*.



## Radiolaria : Their Life-History and Their Classification.

BY REV. FRED'K B. CARTER,

MONTCLAIR, N. J.

[Read before the Department of Microscopy, Brooklyn Institute, February 16, 1892.]

[Continued from page 64.]

The material is now ready for examination. But let no one imagine that this is the work of a moment. My impression is that less care is taken in the case of the Radiolaria than in that of almost any other class of microscopic objects which might be mentioned.

In a dozen years I have seen hardly more than a dozen slides of polycystina exhibited. Search among the cabinets of amateurs and you will find that while they are overstocked with diatoms there are scarcely any slides at all of polycystina. I asked a friend of mine to bring me all the slides he could find of these forms in an unusually large and fine collection of microscopic objects, and he brought me just four. Yet I am sure that the slides of diatoms and the histological slides in that collection must run up into the hundreds. And what of those four? Three were *opaque* mounts, and in one of these the forms were mounted in such a deep cell as to be beyond the reach of an ordinary  $\frac{1}{4}$ -inch objective; only one was mounted as a transparent object and that was a slide of *moving* polycystina, utterly useless for close examination with a high power. But the reason is perfectly plain. As a rule no one thinks of observing them closely or with a high power. At least that has been my experience, for I never saw any of them under a power higher than a half-inch until I began to make a definite study of them for myself. They are regarded as simply pretty opaque objects, to be displayed with the binocular and the  $\frac{3}{4}$  or  $\frac{1}{2}$  inch; to be viewed *as a whole* for a moment or two and then cast aside in favor of some other interesting object. Of course, for show objects, two or three slides are as good as a hundred and the amateur sees no reason for owning more. And in fact he cannot get any variety if he would from the dealers on this side of the water at least. It is rare to meet with a slide for sale from any locality but Barbadoes. I secured one from the Nicobar Islands, but it was the only one the dealer had, and I do not remember ever to have seen another for sale from that locality, and while there are plenty from Barbadoes they are apparently all alike, at any rate so much so that one is not disposed to purchase many at half a dollar apiece. But they are not all alike. One slide will have several forms not on another, and while they are too costly to buy by the dozen, what is to hinder one from making up a couple of dozen of strewn slides of his own, or from picking out the different forms and mounting them separately? They are no harder to pick out than diatoms, and many an amateur has become expert enough for that. Let him go to work at the Barbadoes earth and he will be surprised to see what a variety

there is in that deposit as he mounts one after another. If he is at all thorough about it, it will afford him occupation for a long while, for Ehrenberg found no less than 282 species and Mrs. Bury added to this large list 141 more, while Haeckel says that the total number of species in that deposit alone is probably over 500.

But whether one mount them separately or not let him not be content until he has *practically* isolated each form by using a power high enough to shut out almost all the other forms from the field of view. Begin with the binocular and dark-ground illumination, by means of the Abbe condenser, and carry the powers up to  $\frac{1}{4}$ th,  $\frac{1}{5}$ th,  $\frac{1}{6}$ th. Then use direct light from a flat wick, *dispensing with the mirror* and using a binocular diaphragm, or, in case of a  $\frac{1}{4}$ th,  $\frac{1}{5}$ th, or  $\frac{1}{6}$ th obj., a diaphragm with round opening just large enough to fill with light the back lens of the objective, as may be ascertained by removing the eye-piece and looking down the right-hand tube after shutting off the light from the left, and by all means *diffuse* the light. For this you can use ground glass in your diaphragm ring, but there is something equally good if not better which you can make for yourself for nothing. Take a thin piece of mica and rub it on both sides with emery paper in two directions at right angles to each other. The result is a fine mat surface, and this will prove just the thing to bring out the forms with remarkable stereoscopic effect.

Then when you have finished with the binocular examination take the *monocular* tube and proceed as before, first with dark-ground and then with direct illumination, and go on up from the  $\frac{1}{2}$  to the  $\frac{1}{4}$ ,  $\frac{1}{5}$ ,  $\frac{1}{6}$ , and even  $\frac{1}{8}$ , using every now and then your diaphragm of mica to diffuse the light, for it often brings out minor points beautifully. If you have never tried these higher powers on the polycystina you will be astonished and delighted at the beauty and variety of markings as so displayed, and when I tell you that all of Haeckel's figures are drawn under a power of at least 300 diameters and many of them of 400 diameters you will admit that there is good reason for what I urge, or, if not, a glance at the figures themselves will speedily convince you, if you are fortunate enough to get a peep at them. They are simply exquisite, and there is no end to the variety in the plates of that magnificent work. I began this investigation without knowing anything about the polycystina, beyond such a superficial knowledge as is to be obtained from opaque mounts. But I soon became enthusiastic, and I am confident you will also. And you will surely say to yourself, as I have said, why in the world do not preparers put up separate forms of the polycystina as they do of the diatoms? Why cannot one buy type-slides of them? I see by the catalogue of Möller's diatoms that he has one slide of 72 forms of the polycystina, but they are mounted opaque, which is not the best method for close study, and the catalogue does not tell whether he ever made more than one. In fact, as I under-

stand it, none of those slides are now in the market, nor will they be until after they have been exhibited in some of the principal cities of Europe and of this country. If some of our diatom experts would only put up such slides of some of the most beautiful forms of the polycystina, I am sure they would find a ready sale. I have a slide with just one specimen of *Astromma* on it, put up by Mr. Geo. B. Scott, and it is "a thing of beauty and a joy forever," never failing to call forth admiration. It happens to be quite a large form, and here let me say that the Radiolaria vary considerably in size. I have just measured a dozen or so of them and find that the round forms, spheres, or disks, range from 1-85th to 1-300th-inch. This, of course, is without taking into account the spines, some of which are as long as the diameter of the main skeleton and even longer. In the conical forms, the long diameter, exclusive of appendages, horns, or feet, ranges from 1-90th to 1-400th-inch, while the double forms have a length of from 1-400th to 1-700th-inch. *Histiastrum*, including the arms, measures 1-45th-inch.

(To be continued.)

### How to Collect Desmids.

By WM. N. HASTINGS,

ROCHESTER, N. H.

Desmids are microscopic unicellular fresh-water plants, and belong to the order Algæ. Under favorable circumstances the largest of them may be seen by the naked eye as minute green specks in the water. The smallest of them require a good compound microscope for identification, being of no greater diameter than a human blood corpuscle. They differ from diatoms most strikingly in the cell-wall being soft, and it is said to be composed almost wholly of cellulose (the material of cotton), while the cell-wall of diatoms is infiltrated with silica (the material of glass), which renders them brittle. From other algæ they are chiefly distinguished by each cell being composed of two symmetrical half cells joined at their bases, which are sometimes so much constricted as to appear to be two cells, but as the protoplasm (bioplasm or life substance) circulates from one to the other they really form but one individual cell. Desmids differ from one another in shape, size, markings, and the presence or absence of processes, angles, spines, etc. Over thirteen hundred of them have already been described, and while it seems really wonderful that so many and beautiful forms can be fashioned from a single cell, the student will readily understand that the possibilities are almost infinite. Desmids have a small power of motion, which is usually so slight as to escape observation, but it is sufficient to extricate them from sediment when they are not too deeply buried. By secretion of a sort of mucus they are able to anchor themselves

to the bottom, and also to rise a perceptible distance above it. What use we can make of this peculiarity will be seen later on.

Of what benefit are they? will be asked by the practical man. We can truthfully say that they are an ultimate source of food for man; they are eaten by small animals, and these become the food of fishes. Students will recall numerous instances of desmids seen in the stomachs of infusorians. Some small snails eating large closteriums not only satisfied their appetites, but gave a pleasant half hour to the writer a short time since. Their actions were comparable to those of a small cow with a large ear of corn.

While desmids may be found at any season when we can get at the bottom of shallow ponds, the best will be found when all plant life is in vigorous growth. Sink-holes which have no visible outlet, and from which the water never entirely disappears, are generally excellent gathering places. Shallow ponds, still, shallow coves of lakes, mill ponds, and quiet pools in streams are promising resorts. They may often be plentifully found clinging to the long water-weeds, from which they may be detached by dipping the weeds into a bucket of water and rinsing them up and down. The size of the pool often bears no relation to its importance. A small cavity in low ground, from which the moisture almost but never quite disappears in times of drouth, and which is scarcely two feet across, has produced two new forms. It was formerly the bed of a small granite boulder, and is lined with a growth of sphagnum moss, from which it seems always possible to squeeze a few drops of water, and when driest yields semi-cells of the plants free from chlorophyll and in best condition for examination of their markings. A small depression in a similar place, apparently made by the pressure of an ox's foot, was a valued treasury for several months, though it gave no forms new to science.

The outfit for gathering samples of water need be neither large nor expensive. A dozen one-ounce wide-mouthed round-shouldered prescription vials, costing, with their necessary corks, twenty-five cents, a pond-stick cut from the roadside, a hand magnifying glass, costing another quarter, and a small memorandum book are the only requisites for preliminary search. The pond-stick is usually a grey birch about three-quarters of an inch in diameter at the large end, which is flattened on opposite sides for about six or seven inches, split vertically to the flat sides, and a notch cut from the inside of each jaw forming the sides of the split, so that they may securely grasp the neck of the one-ounce vial. Having secured a sufficient number of samples from localities whose names and descriptions are recorded in the book, they are taken home and carefully examined under the microscope. Always enter the names of localities in a permanent record, and label each vial with the name of locality and date of gathering. It will save many regrets. If any region gives sufficient prom-

ise it should be visited again and a larger quantity of material secured. This time the outfit consists of a lard pail containing three or four fruit cans fitting one into another, and a self-sealing fruit jar. The top sediment is carefully gathered and put into the cans to settle, which, when enough has been obtained, is put into the jar, sealed up, and carried home. A portion is taken out for examination as it is. The rest is strained through lace—mosquito-netting will do. This takes out the filamentous forms that interfere with the next operation. Desmids usually occur as free or single cells; but some beautiful forms are usually joined into filaments, and these will be found in the unstrained sediment. After straining the material is put into one-ounce vials, a little in each. The vials are filled with fresh water and set aside in good light until the next day, or sometimes until the second day, when the desmids will be found on the surface of the sediment, or, if entirely successful, they will be found separated from it by a layer, the mucus before spoken of. They may be removed without disturbing the sediment by carefully using a rubber-capped pipette. This material will be made up of nearly clean desmids, and is much more satisfactory for examination than the usual mixture of desmids and dirt. If the operation is not entirely successful and some sediment is found, it may be sometimes repeated, but it is best to be careful (and hence successful) the first time. To preserve this cleaned material, which would otherwise soon become foul, it may be put into a one-ounce vial of water with five drops each of glycerine and strongest carbohc acid. The acid will preserve it and the glycerine will prevent loss by drying out under the microscope, which is very provoking when one is studying a rare form and forgets to renew the water. This preservative answers as a mounting fluid unless it is desired to preserve the color, in which case carbohc acid must not be used. Pure glycerine has preserved a fine green color for several years, but the endochrome has always been shrunk from the cytoderm. The slides must be kept from the light as much as possible to prevent bleaching. Having generally wished to get rid of the cell contents not much can be said as to their preservation. Time and natural causes are principally relied upon for their removal, as no chemicals have been tried that do not act injuriously upon the markings of the cell-wall. These markings can be well made out only upon empty cells; best of all are those found empty in the gatherings, and some empty semi-cells may usually be had by careful search among the sediment in which the living cells are found. When they are not found patient waiting and occasional examination are the remedy.

In order to find new forms do not take too large a field for study. Make yourself thoroughly familiar with one small section of the subject, and you will be prepared to recognize anything new in that section. Do not dilute your attention with too much to observe. When you have found something you think new

carefully measure it in all directions and positions by aid of a good eye-piece micrometer and make a drawing from the measurements, which should be thoroughly verified by repeating them, remembering that from their shape desmids usually present themselves in a more or less perspective and therefore unsymmetrical view. On this account camera drawings and pictures of desmids have not the value of a good drawing from careful measurement, since it will be only by accident that the desmid will present itself symmetrically. The micrometer used by the writer is a system of silk fibres stretched across the opening in the diaphragm of an eye-piece, in accordance with instructions in *The American Monthly Microscopical Journal*. It is almost continuously in use.

Having convinced yourself that your discovery is a new plant, write its description in terms of botanical nomenclature (Wolle's Desmids offers good examples), and publish in your local newspaper, a copy of which with a copy of your drawing can be sent to your correspondents or to a scientific journal for publication. The drawing may be copied by photography or other methods. A printed copy is best for ultimate publication, for written descriptions are apt to be strangely translated. Do not be too sure that your find is new. Mistakes are awkward, and while not always avoidable, detract from the value of one's work not only to others but also to one's self.

### On Imbedding Animal Tissues in Paraffine for Sectionizing.

By PROF. H. L. OSBORN.

HAMLIN, MINN.

This method of preparing animal tissues for sectionizing is described in all books of microscopical technique, and the description presented here merely repeats from them without adding any specially new features. Since every detail in this connection is important, I will risk being tedious and attempt to give an account by following which anyone can be sure of success. Every step of the process must receive careful attention to insure success. The work can conveniently be subdivided into several parts.

1. **Fixing or Hardening the Tissue.**—One of the best modes of hardening is by the picro-nitric acid method. Prepare the hardening fluid as follows: Dissolve picric acid crystals in distilled water to saturation, add 2 per cent. of strong nitric acid; a heavy precipitate will fall; filter and keep the filtrate for standard solution. Place in this standard solution, weakened with one-half or two-thirds water, a piece of perfectly fresh tissue from a just killed animal, or for small animals immerse the entire creature. Leave it in from 3 to 6 hours. Then transfer it to 30 per cent. alcohol, and in a few minutes thence to 50 per cent., and after an hour to 70 per cent. Keep it in 70 per cent., changing the alcohol daily till

no yellow color is imparted to the alcohol by the specimen. It is then ready for staining.

2. **Staining.**—Prepare a solution of borax carmine as follows: Carmine, 1 gramme; borax, 4 grammes; distilled water, 56 c.c. To this solution add its volume of 70 per cent. alcohol and filter. The solution thus made will keep indefinitely. Immerse the specimen after completion of hardening in the borax carmine solution, and leave it 24 hours. It will then be evenly stained (provided the acid of the picric has been perfectly removed by alcohol washing). To wash out over stain of borax carmine, immerse the specimen for a few minutes in 70 per cent. alcohol, to which 2 per cent. hydrochloric acid has been added, and in renewed washes as long as color is removed by the washing fluid. Then place in a considerable amount (20 vols.) of 95 per cent. alcohol, and finally in absolute, and leave for several hours. At this step great care is needed for the paraffine imbedding imperatively requires the entire removal of water from the tissue.

3. **Imbedding.**—After the water has been removed, the specimen is to be placed in spirits of turpentine and left there until it becomes very translucent, all the alcohol being replaced (or chloroform can be used equally well or, perhaps, better than turpentine) after a period of twelve hours for a piece the size of a one-half inch on a side, the specimen is transferred to a mixture of turpentine (or chloroform) and paraffine which is fluid but nearly saturated. Here it stays another period of twelve hours, when it is ready for its final bath in pure paraffine. A too hard paraffine will interfere with the operation of the razor in section cutting. The paraffine must be kept melted at a temperature of 66° C. and positively must not rise to 70° C. A water bath is needed for the purpose. The specimen should remain several hours in this bath till all trace of the turpentine is gone by evaporation. Then the specimen can be removed and moulded in a block of paraffine. If this process is wholly successful, the specimens will keep indefinitely. I have some now which are 8 years old and good yet, and sections can be cut out at any time.

4. **Section Cutting.**—In sectionizing, the specimens should be cut with a direct and not a sliding movement of the razor; the temperature of the room should be just right and the razor sharpened just to the right degree and its movement at the proper speed; a slice of almost any thinness can then be cut. But all of these requirements must be carefully fulfilled or exasperating failures are likely to occur. After the sections are obtained they should be cemented to the slide. The white of egg method is very easy of application. Spread a thin even film of white of egg on the slide and lay the section upon it. Heat gently over a lamp until the paraffine melts; this coagulates the albumen. Then set aside until the albumen has hardened. Then cover the specimen copiously with turpentine and dissolve the paraffine; remove the superfluous turpentine and add Canada balsam in

benzine or chloroform, cover, and the section will be ready for study. The sections from which the study of *Lumbricus* were prepared were made by this method, and though it is extremely "kinky" it gives the most satisfactory results.

March 3, 1892.

---

## EDITORIAL.

---

**Trip on a Cunard Steamship.**—Wishing for a first trip abroad, a quiet and economical passage to Europe, we obtained the circulars of several lines and visited such steamers as were in port. The *Gallia* cabin No. 11 was engaged for two persons. Baggage was put aboard the day before, and we might have slept on board if we had desired. In the morning of May 26, at eight o'clock, and not a minute late, the gang-plank was pulled off and a tug took us into the channel of the Hudson river. The day was bright, and of course everybody was on deck: within 10 minutes the passengers had been sorted out and second-class passengers roped off within a quarter of the deck and amidships. Neither second nor third-class passengers were allowed aft of the rope, which space was occupied by first-class passengers. But first cabin people had the privileges of the entire deck, and many made free use thereof. This restriction constitutes one of the vital differences between first and second-class passage. It is rather inconvenient to be confined to a small part of the deck and one's pride is likely to be a little hurt, but beyond that there seemed to be no objections to it. The associations were not low nor bad. The people were clean, well behaved, cordial, and in moderate circumstances. The same people would live in cottages or comfortable apartments on shore; would occupy the medium-priced seats in churches and theatres, and make up the bulk of citizens in any community. Many a school teacher who has to work for \$500 per year had better take such a passage for a summer vacation than not go to Europe at all.

In 2½ hours we had got outside of Sandy Hook, had seen the pilot swing off, letting himself down a rope, hand over hand, till he landed in a row boat which was awaiting him, and had replaced our hats with caps which the wind might not steal. Deck chairs were placed and many people settled down to reading. Ladies and invalids better carry steamer chairs, but men and boys do not need them at all. An overcoat that may be soiled with salt spray is almost a necessity.

In our state-room (or cabin) we had a lounge besides the two bunks and plenty of room for two. Though an "inside" room, it was sufficiently light, clean, and airy.

Before dinner time the steward had adroitly got the age, occupation, and general appearance of each first-class passenger, and had assorted them accordingly, placing the people where he de-



sired—most cultured near the captain or other officers, putting young people nicely in reach of each other, and the undesirables by themselves. Caste, if you choose to so call it, is of considerable account in the first cabin. Probably no attention is paid to these matters in the second cabin.

The food was served in courses, and was equal to that ordinarily found in a \$3.00 hotel. The second-class table might be compared with a \$2.00 hotel. But during the days of storm, when the racks are on the tables, it matters little whether the table is set for a \$3.00 rate or a \$2.00 rate! Few people get to it then. At each dinner was a printed bill of fare. Your own waiter always looks carefully to your wants in first-class, being mindful of the fee of from \$1 to \$2 which he hopes to get at the conclusion of your last meal on board. In second-class very small fees are paid, and attention is not quite so perfect. It is, however, sufficient for reasonable people.

For three days, until after passing the Banks, the sea was smooth and everybody was in a happy mood. Deck billiards on the outside competed with walking and reading for precedence. But in mid-ocean the barometer fell till it marked about 29.3. We ran straight into a storm ahead, and during one night it amounted to almost a hurricane. Next day people found a reclining posture far preferable to the erect, for the sea had been trying to get to the erect position and with its frantic efforts the passengers would not sympathize. But the *Gallia* is a splendid sea ship. She rode the billows magnificently and no one seemed to fear for safety even in the storm. It is said that Captain Ferguson, being offered the command of any ship in the Cunard fleet, chose the *Gallia* as the safest. Then, too, she is not a time-maker nor a record-breaker; he is not obliged to endanger machinery and lives in the desperate efforts to compete with other ships. A nice and safe passage of 8 to 9 days is better than a risky passage of from 6 to 7 days. And so it was a week before we sighted land—the southwest coast of Ireland. What a thrill of satisfaction, however, that evening at dusk when we saw the light and signalled to the keeper our name, to be telegraphed to Liverpool. We arrived off Queenstown about 2 the next morning, but fog prevented connection with the tender and we proceeded all day up St. George's Channel, meeting now numerous craft, and feeling along carefully in the fog. At length, we turned into the mouth of the Mersey, and steamed up opposite the Prince's landing stage, where we disembarked at Liverpool by means of a tender at 10 o'clock at night. But, unlike the American customs officers, who will keep a shipload of people on board all night, the Queen's representatives were on hand and quickly passed the baggage, simply asking for tobacco, perfumery, and a few luxuries.

Our trip on the *Gallia* was so satisfactory that we have engaged passage again for July 13, 1892, and hope there may be some of our readers going along at that time.

### MICROSCOPICAL APPARATUS.

---

**A Revolving Table.**—I. Saw out a circular board 18 inches in diameter and ornament the edge if you choose. On the under side, and about 2 inches from the edge, place 4 castors equidistant, and have the board rest firmly on them. In the centre of the underside bore a hole nearly through the board and insert a piece of brass tube. Stain or paint the board at pleasure.

II. Cut a piece of thick pasteboard 18 inches square and to the centre of it fasten a block 2 x 2 inches by 1 inch thickness, letting a brass pin stick up an inch from its centre, having it of such size as to work loosely in the tube.

III. Place the second apparatus on a small stand or table, adjust the first apparatus over it so that the pin will fit into the tube, revolve the top part upon the pin as a centre guide and upon the castors as lateral supports. If the castors are noisy make a track with felt for them to run on.

This is the device of Mr. F. S. Morton.

---

### MICROSCOPICAL MANIPULATION.

---

**Glycerine**,  $C_3 H_5 3 H O$ , is the hydrate of the trivalent radical glyceryl. It is a sweet syrupy liquid, obtained by the decomposition of fats and oils, principally as a by-product in the manufacture of candles and soaps. The fatty acids are used to make candles and soaps, when combined with soda or potash. Pure glycerine is colorless and odorless, freely miscible with water and alcohol in all proportions; but with oils it only emulsifies, and does not perfectly blend. It is a solvent of many alkaloids and their salts, as well as resins. The purest is prepared by distillation; although not volatile without decomposition, yet it passes over undecomposed in the vapor of water, and may be concentrated by careful evaporation. This mode of preparing it was patented by Price's Candle Company, but now much distilled glycerine is imported from Germany. Glycerines of inferior quality have a disagreeable smell, and are sometimes colored. Good glycerine should not be colored after being subjected for two hours to the action of an added solution of the nitrate of silver.—*Cole.*

**Glycerine Jelly.**—Take of gelatine, 300 grains; distilled water, 6 ounces; glycerine, 6 ounces; rect. spirit, 6 drams; white of egg, 6 drams; salicylic acid, 12 grains. Let the gelatine soak thoroughly in the water, then dissolve in a water-bath: add the spirit, and mix well. When cool, but still fluid, add the white of egg, mix, and heat to boiling point to completely coagulate the albumen; add the glycerine with the salicylic acid in it by the

aid of heat; mix well and filter, while still hot, through paper previously moistened with distilled water; the whole should be kept in a hot chamber whilst filtering.—*Martindale*.

**Dead Black.**—To 2 grains of lamp-black add 2 drops of gold size and thoroughly mix. Then add 24 drops of spirits of turpentine and mix. Apply with a thin camel-hair brush.

**Smith's Method of Drawing.**—Place the body of the microscope horizontal; remove the mirror; put the slide on the stage; condense the light upon it by means of the bull's-eye, taking care to centre the light; attach the concave mirror to the front of the eye-piece by means of a spring or a piece of thin wood. Have its surface at an angle of  $45^\circ$  with the plane of the anterior glass of the ocular. This will project an image of the object on the paper beneath. If the outer ring of light is circular, there will be no distortion. With a black cloth exclude all outer light, covering both your head and the instrument. Mr. Hopewell Smith draws any section easily in this manner, including magnifications of 600 diameters.

---

### BIOLOGICAL NOTES.

---

**Fungus Study.**—In all the agricultural experiment stations the microscope is an important instrument. In no respect is botany advancing to-day as in the study of the life-history of the vegetable pests that send their unseen spores everywhere. Prof. Halsted has given in the *Botanical Gazette* for April some of the habits of fungi and has shown how the harboring of certain weeds induces the multiplication of fungi parasitic to them, and how the spores thus produced are carried to cultivated plants. Thus 41 species of plants, many of them common weeds, harbor that fungus which, when transferred to lettuce, is known as mildew. The whole history of the fungus thus becomes interesting.

**Agassiz** was once asked to write a text-book in zoölogy for the use of schools and colleges. Of this he said: "I told the publishers that I was not the man to do that sort of thing, and I told them, too, that less of that sort of thing which is done the better. It is not school-books we want, it is students. The book of nature is always open, and all that I can do or say shall be to lead young people to study that book, and not to pin their faith to any other."—*From "Agassiz at Penikese," in Popular Science Monthly.*

**Salmon and Sturgeon in Idaho.**—Prof. C. Hart Merriam saw salmon at Lewis Ferry on Snake river, Oct. 15, and learned that individuals were at times taken weighing 600 pounds. He saw several tied to stakes by their tails, one of which weighed 150 pounds. The fall run of salmon reaches that place about October 10; those that do not die go back in November. Indians

were then on their way to the river to spear salmon, some of them having come a long distance for the purpose.

**Cedar Trees and Apple Rust.**—Prof. B. D. Halsted gives some interesting facts regarding the apple rust (*Rastelia*) that yellows the foliage of the orchard in July and shortens the crop at picking time. He says: "This fungus plays a double rôle and seems unable to get along with the apple tree alone. In a second and very different form, *Gymno-sporangium*, it infests the cedar trees, there forming knots or galls that become conspicuous as gelatinous balls during the spring rains. These orange-colored balls furnish the spores, which, falling upon the foliage and fruit of the apple tree, produce that fatal rust. Later in the season the spores from the apple fungus go back upon the wings of the wind to the cedar and a new crop of galls is obtained for next spring's campaign against the orchard. In this case it is not wild apple trees or those of the same family that harbor the enemy, but a tree as widely separated botanically from the apple as is well possible. More than this, the fungus changes its form in passing from one to the other so that it was not until demonstrated by actual cultures that the relation, long suspected, could be fully believed. It is needless to say that the very evident method of procedure is to destroy cedar trees that are anywhere near the apple orchard. A single large gall-bearing cedar tree just outside the orchard fence may do more mischief than any enemy that is lurking within the enclosure."

**Arbor Day.**—By proclamation of the Governor, April 28 was observed in Michigan as Arbor Day. He appealed to all the people to plant trees along the highways and about their homes, so that flowers, shrubbery, and fruit trees may add to the happiness of every passer-by.

---

## DIATOMS.

---

**To Work the Diatomaceous Earth Sent out by This Journal.**—1. Boil the material in clear filtered water, let it cool and settle. Carefully pour away the surplus water, add fresh, and boil again. Repeat this boiling and washing until the water remains clear; finally decant the water, leaving the diatoms as dry as possible.

2. Add half a drachm of strong nitric acid, boil thoroughly, drop a small crystal of bichromate of potash into the hot acid, boil again for several minutes. Add clean water and allow it to settle; pour away this acid water, add fresh, and repeat this washing until the water remains clear and neutral.

3. Add a piece of clean soap, about the size of a pea, and a little water to the diatoms, boil thoroughly, add fresh water, and allow plenty of time for the smaller diatoms to sink through this

thick liquid; pour off the soapy water, and continue the washing until the water is absolutely clean.

Examine a minute quantity of the material with the microscope; if the shells are not clean and bright begin again with the nitric acid and bichromate and follow with the soap as before. Use a four-inch test tube and a lamp of any kind. When boiling have about half a teaspoonful of fluid in the tube; when washing fill the tube with clean water. Revolve the test tube sharply between the fingers at times during the process of settling, to detach diatoms adhering to the sides of the glass tube. Do not hurry the boiling or the settling processes. Pour off the wash water very slowly so as not to disturb the deposit in the bottom or the test tube. Keep the cleaned diatoms in a small vial of clean water.

**To Mount Diatoms "Dry."**—All "dry" mounts of diatoms, whether "strewed" or "selected," are liable to destruction or deterioration from an accumulation of moisture upon the under side of the cover, which moisture, sooner or later, and in defiance of all precautions, always makes its appearance. "Dry mounts" are, therefore, always more or less unsatisfactory and unreliable and to be avoided as much as possible. The best method of mounting diatoms "dry"—whether for "test" or as "arranged" slides—is to make a cell of the *best* asphalt, of the necessary thickness by adding coat upon coat of the asphalt, *not* by making the cell of sufficient depth at one operation. Spread the diatoms upon the cover; if necessary "burn" them upon the cover, *i. e.*, place the cover upon a piece of thick platinum foil and raise it, slowly and carefully, to a dull red heat over the flame of a "Bunsen" burner; thoroughly heat the slip with the asphalt cell upon it; whilst it is *hot* (and therefore *certainly* free from all damp or moisture) place the *equally hot* cover carefully upon the cell, pressing down the cover and making sure that it adheres thoroughly and evenly to the cell; run a ring of asphalt round the edge of the cover; when this is hard, ring the cell with two coats of white zinc cement, letting the first coat dry thoroughly before applying the second.—*Cole*.

**Hudson River "Fiord."**—Dr. Arthur M. Edwards has been for some time investigating the deposit thrown down during the Champlain period in the Hudson river, New York, more especially to find out if it is the same as that of the bay of Newark, N. J., and has decided that they are different, that of Newark being newer than that of the Hudson river. He has examined the soundings from the Hudson river "Fiord" made by Mr. A. Lindenkohl, of the U. S. Coast Survey.

A list of the forms identified may be found in *The American Journal of Science*, vol. xliii, March, 1892.

The microscopic organisms are not those of the Newark bay, as they are not of brackish or fresh-water origin as those are, showing the "Fiord" is not a continuation of Newark bay but rather of the Hudson river.

## BAACTERIOLOGY.

---

**Pasteurized Milk.**—All methods of sterilization that are in use in this country have the disadvantage of giving to the milk the taste which is peculiar to boiled milk, and also of rendering it less easily absorbed by the body. In France and Germany a method has been adopted which accomplishes the purpose without injuring the taste of the milk. Machines are in use in Paris and some other cities which will heat great quantities of milk to a temperature of about 155° Fahr. for a few minutes, and then cool it rapidly to a low temperature. The method has been called the pasteurization of milk. It does not kill all the bacteria, but it does destroy so many of them that it greatly increases the keeping properties of the milk. Moreover, it almost entirely destroys the danger from disease-germs in milk, since nearly all forms likely to occur in milk are killed by this temperature. The advantage of this method is that the temperature of 155° Fahr. does not give to the milk the taste of boiled milk, which most people find unpleasant, and does not render the milk difficult of digestion. These pasteurizing machines have not yet been introduced into this country, and the opportunity exists for some one to develop a thriving business by furnishing pasteurized milk in our large cities. A little experience with its superior keeping properties and a little knowledge of its great wholesomeness would soon create a demand for it in America, as it has already done in the larger cities of France and Germany.—*From Bacteria in our Dairy Products, by Prof. H. W. Conn, in The Popular Science Monthly for April.*

**A Bacterial Disease of the Potato.**—This disease was first noted by Prof. T. J. Burrill, of Illinois; the same rot of the tubers has been described by B. D. Halsted.

The rot is believed to be due to a specific organism. It shows itself by a wilting and premature dying of the vines, preventing in the immature condition of the tubers their further development, or causing their destruction in the soil through decay. Tubers thus decayed give off an extremely offensive odor, become soft and mushy within, and emit a milky matter from places where the skin has been injured. In the former case the decaying tubers have a strong earthy smell so distinct from the other that there is no danger of confusing them.

The question of treatment is one upon which no positive information can be given. It has been claimed that the trouble can be held in check with the Bordeaux mixture. This, however, was not the case in certain experiments in which several potato plots were sprayed throughout the season with the Bordeaux mixture, but in spite of heavy applications the plants went down completely before the tubers were the size of walnuts.

### RECREATIVE MICROSCOPY.

**Microscopic Mounts of Minerals in Boxes.**—The difficulty of examining minerals with the microscope has heretofore been very great. Various inventions have from time to time appeared endeavoring to overcome the difficulties. If a fragment or portion of a mineral is mounted upon the usual glass slide of the microscopist, it is clumsy, requires too much room, and is not protected easily by the cover-glass without making so deep a cell that light cannot be thrown into it by the condenser in a manner entirely satisfactory.

Perhaps the best manner of mounting the delicate crystals is to fix them in paper boxes, about one inch square, the inside of each little box being of black paper, like the dead color of the inner surface of the tube of the microscope. No cover-glass is in the way to refract or prevent the light from penetrating into the little cavities of the specimen where the small acicular or tabular crystals have formed and where they are protected from injury.

As a still further protection the box may have a cover of a light colored paper which fits perfectly; and all be contained in covered paper tray-boxes, each tray containing thirty small mineral boxes. One-and-a-half or a two-inch objective will be found the most effective. If a good strong light is thrown upon the mineral there is nothing more beautiful.

The following are a few of the boxed micro-minerals that can be bought for 25 cents each:

Analcite, adamite, azurite, apophyllite, anglesite, aurichalcite, axinite, blende, braunite, brochantite, byssolite, biotite, bournonite, calamine, chalcotrichite, conichalcite, copper (native), cuprite, clinoclasite, chalcophanite, celestite, descloisite, erythrite, erinite, franklinite, fluorite, garnets, gold (crystals), gothite, hematite, hydromagnesite, hematite and quartz, irridium, itacolomite, jarosite, laurionite, lava, marcasite, malachite, muscovite, mimetite, osmium, olivenite, onegite, platinum sand, pele's hair, pyrite, petrified wood, pyroxene, polybasite, phillipsite, quartz (crystals), rutile, silver (native), sulphur, stibnite, spinel, stephanite, serpierite, smithsonite, scorodite, tyrolite, tenorite, torbernite, ulexite, vanadinite, vesuvianite, variscite, wulfenite (red), wulfenite (yellow), wavelite, zircons.

**Lycopodium.**—To subdue one's aversion to taking pills, show him what a beautiful object the adhering powder is when seen under the microscope. Druggists use the club-moss or ground pine spores to roll the pills in to prevent their adhering. One can sometimes make some fine mounts out of the waste powder of a pill-box. Blest be he who first invented pills.

**Arranged Diatoms.**—These always afford entertainment. W. H. Pratt, of Taunton, Mass., has made some nice slides from American diatoms.

## MICROSCOPICAL SOCIETIES.

## THE ST. LOUIS CLUB OF MICROSCOPISTS.

*January 5, 1892.*—The monthly meeting was at the St. Louis College of Pharmacy building. Dr. J. C. Falk, the president, gave a paper on the Examination of Sediments in Urine. The Club ordered several books added to the library. This organization is just coming to be one of the foremost of its kind, though the present quarters are not hardly suitable. When the new St. Louis College of Pharmacy building is completed it will have quarters in that building, where members and their friends can go at any time and use the fine lot of slides and literature of all kinds.

## WASHINGTON, D. C.

*Tuesday, Jan. 19.*—A paper was presented by Dr. Seaman on the Radiolaria, with exhibition of a large number of slides from Hæckel's collection from the *Challenger* expedition. Then followed an exhibition by C. W. Smiley of Stratton's illuminating apparatus.

*Feb. 2.*—Paper by Dr. V. A. Moore on recent methods for preserving and examining sputum for tubercle bacilli, with exhibition of slides illustrating the method.

*Feb. 16.*—Paper by Dr. Geo. H. Penrose, with exhibition of tubercular sputa undergoing treatment by creosote.

*Mar. 1.*—Paper by Dr. W. W. Alleger on methods of preserving and mounting urinary deposit, accompanied with slides.

## THE MONTREAL MICROSCOPICAL SOCIETY.

*Jan. 11.*—It was expected that Prof. Cox would give a paper on polarized light, but owing to his indisposition the lecture had to be postponed. Instead, the members were requested to bring slides or other objects of interest, which several of them did, and a very successful meeting resulted.

*Feb. 8.*—Jos. Bernrose read a paper on "Crystalline Forms Modified by Impurity." The formation of crystals was carefully explained, and the effect of impurities on the forms of crystals described. Poisons forming crystals, it was stated, could be detected, separated from food, examined microscopically, and the kind of poison identified by its crystals. The lecturer had especially prepared a large number of slides to illustrate his subject, which demonstrated that there was great beauty of form and color, and also other delightful as well as scientific results to be obtained by the careful study of crystals. The polarizer was largely used in demonstrating the structure of the crystals exhibited.

*Feb. 26.*—A special meeting was held to hear Prof. Cox's paper, "Polarized light: its usefulness in indicating structure." Microscopical and electrical apparatus was used for extensively illustrating the paper, an abstract of which will be furnished.



## MONTREAL MICROSCOPICAL SOCIETY.

*January 11, 1892.*—At the regular monthly meeting the President, Mr. J. Stevenson Brown, occupied the chair, and Prof. Cox's lecture on "Polarized light: Its usefulness in indicating structure," was postponed, as he, through illness, was unable to be present. A very profitable evening was then spent in a conversational way. Mr. Brown made a few remarks on the *Paramæcium aureliæ*, referring to their amazing fecundity and their peculiar manner of reproduction by "fission" or duplicative subdivision, illustrating his remarks by living specimens taken from water which he had brought for that purpose, and which under the microscope showed many beautiful and wonderful details of structure. Mr. James Ferrier followed with an explanation of a series of prepared slides which were shown to perfection, after which Dr. Girdwood exhibited a variety of crystals and showed how their angles could be accurately measured by a beautifully adjusted arrangement of spider web in the eye-piece and other apparatus attached to the stage of the microscope. Mr. Leslie Skelton brought for the entertainment of the members an apparatus showing how ants could be kept alive during the winter in the house, without the slightest inconvenience or chance of the little creatures wandering away from the particular space allotted to them, and showed a nest of ants between two sheets of glass, where they could be observed working in the earth and making their various passages from one part to another.

## OMAHA MICROSCOPICAL SOCIETY.

The Society meets weekly at its rooms, 212 Karbach Block; Prof. Leviston, President, Dr. Wilkinson, Secretary. It has a botanical section and a medical section. Prof. Lighton is one of the active workers.

## ESSEX COUNTY, MONTCLAIR, N. J.

*Sept. 24, 1891.*—The following officers were elected for one year: President, Frank Vanderpoel; Vice President, Albert Mann, Jr.; Secretary, C. M. Marvin; Treasurer, F. B. Carter.

## IRON CITY MICROSCOPICAL SOCIETY, PITTSBURGH, PA.

*Tuesday Evening, March 8th.*—Dr. Daggett read a very interesting paper on "Crystals." He defined and illustrated the various systems of crystallization and explained the variations.

His paper was supplemented with an exhibition of slides showing the leading types of crystals. The two forms of crystals obtained by adding mercuric chloride to potassium iodide were shown on one slide. Other slides shown were: (1) "Child's tear," showing crystals of sodium chloride; (2) nitrate of silver; (3) arsenious acid; (4) cinchonidine; (5) sulphate of cobalt; (6) soda biborate; (7) copper sulphate; (8) guanidine; (9) acetanilide. After the paper the various theories as to the cause of crystallization were discussed by the members.

Prof. Tingley described how artificial snow crystals could be formed; put a few drops of strong *aqua ammonia* near the middle of the slide; right adjacent to the ammonia put a few drops of spirits of camphor. The vapors from each unite, produce intense cold, and crystals are formed under the objective (a 2-inch is to be preferred).

#### NEW JERSEY STATE MICROSCOPICAL SOCIETY.

*January 25th.*—The President, Rev. Samuel Lockwood, read a paper on the "Blood of Kemmler," and exhibited slides. This being the 21st year of existence of this Society, a committee was appointed to arrange for a celebration of the event.

#### NEW YORK MICROSCOPICAL SOCIETY.

*April 22d.*—The 13th Annual Exhibition was held at the American Museum of Natural History. Nearly one hundred instruments were in use and various microtomes, illuminators, photomicrographic apparatus, etc. Lantern slides were projected in an adjoining room by three different exhibitors, each occupying 30 minutes.

### NEW PUBLICATIONS.

*Review of Artesian Horizons in Southern New Jersey.* By Lewis Woolman.

This is a paper of 12 pages from the Report of the New Jersey State Geologist for 1881, showing their persistence and extension southward beneath the Atlantic Coastal plain and their relative positions within and beneath a 300-foot diatomaceous clay bed.

This bed extends also into Delaware. At Malcom's Mill the diatoms are very abundant and readily seen by transmitted light. At Emerson's Mills they are coated with iron pyrites, but may be seen with reflected light. At Herring Bay is found a bed characterized by *heliopelta*.

The paper is accompanied with a plate of some 50 diatoms from an artesian well-boring at Beach Haven, N. J. The forms were mounted by Dr. D. B. Ward.

*General Bargain List.* Williams, Brown & Earle, Tenth and Chestnut Streets, Philadelphia, Pa.

This is a list of all sorts of microscopical material at reduced prices. Those needing goods should send a postal card requesting a copy.

*Catalogue of Williams & Norgate's Publications.* January, 1892. London.

These are the well-known publishers of the Journal of Royal Microscopical Society and of Quecket Club. We notice also many of Herbert Spencer's works in the list. There are five of Cooke's works, including the British Algæ and British Desmids. The catalogue is sent to applicants who enclose return postage.



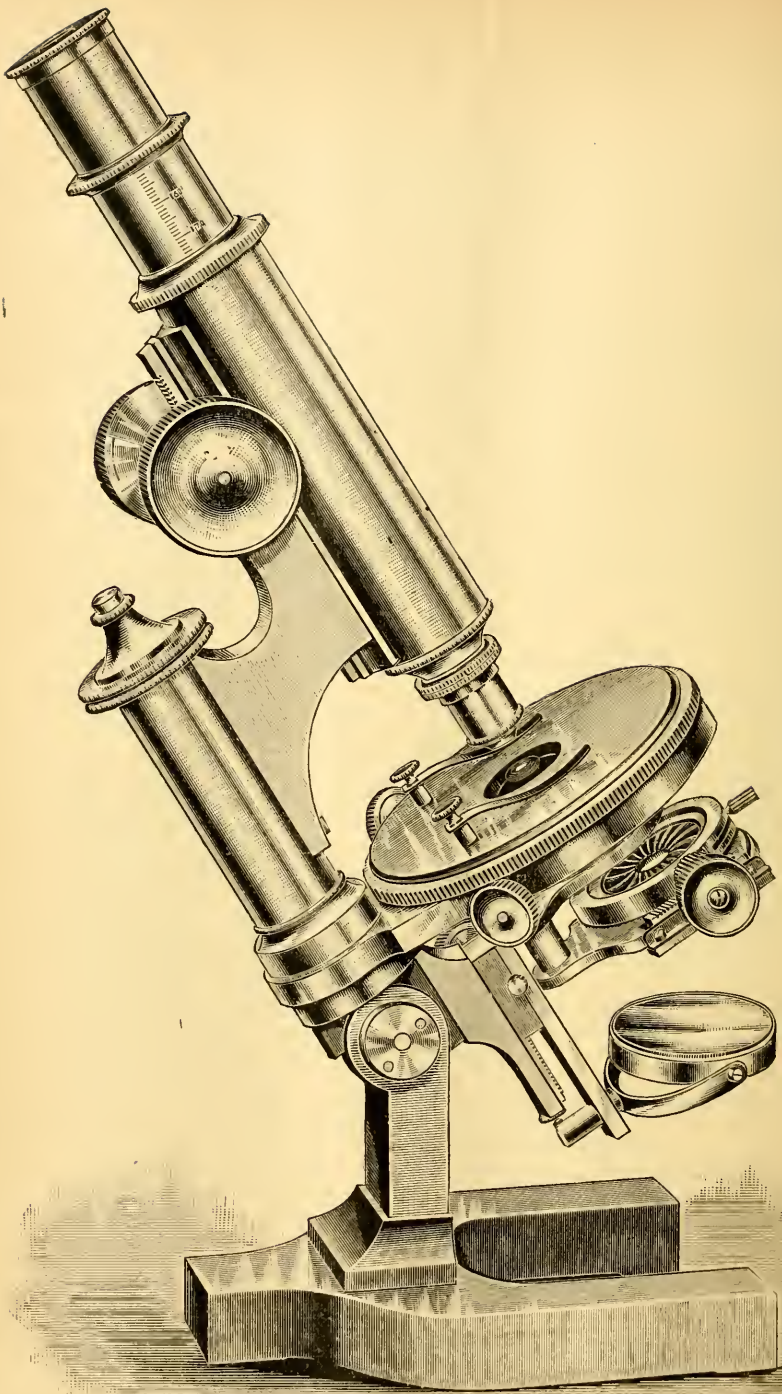

BAUSCH & LOMB'S NEW MICROSCOPE.

# THE AMERICAN MONTHLY MICROSCOPICAL JOURNAL.



VOL. XIII.                      **JUNE, 1892.**                      No. 6.

## CONTENTS.

<p>On the Continuity of Protoplasm through the Cell Walls of Plants (Illustrated).—BEAL and TOUMEY - - - - - 129</p> <p>Impressions of the Antwerp Microscopical Exposition.—WARD 133</p> <p>An Interesting Study of Living Micro-Organisms.—GIBBES - 141</p> <p>Radiolaria: Their Life-History and Their Classification.—CARTER - - - - - 143</p> <p>EDITORIAL.—Proceedings of the American Society of Microscopists - - - - - 145</p> <p>MICROSCOPICAL MANIPULATION.—Poisoning Protoplasm with Quinine. To Prepare Lignite. Transparent Cement. Using Oil-immersion Objectives. Preparing Sponges - - - - 146</p> <p>BIOLOGICAL NOTES.—Teaching</p>	<p>with the Microscope. Weed Extermination. Effects of Electrocutation. How Seal-skin is Prepared - - - - - 147</p> <p>DIATOMS.—What are Diatoms? Cleaned Material - - - - - 148</p> <p>MEDICAL MICROSCOPY.—Microscopy for the Druggist. The Clinical College of Medicine and Specialty Hospital. Sweating. Pasteur Institute. 149</p> <p>MICROSCOPICAL NEWS.—A Silver Medal for Dr. Taylor. An Electric Microscope. E. H. Griffith. Bausch &amp; Lomb's New Buildings - - - - - 150</p> <p>CORRESPONDENCE - - - - - 151</p> <p>MICROSCOPICAL SOCIETIES.—Washington. San Francisco. St. Louis - - - - - 151</p> <p>NOTICES OF BOOKS.—Gould. 152</p>
-------------------------------------------------------------------------------------------------------------------------------------------------------------------------------------------------------------------------------------------------------------------------------------------------------------------------------------------------------------------------------------------------------------------------------------------------------------------------------------------------------------------------------------------------------------------------------------------------------------------------------------------------------	-----------------------------------------------------------------------------------------------------------------------------------------------------------------------------------------------------------------------------------------------------------------------------------------------------------------------------------------------------------------------------------------------------------------------------------------------------------------------------------------------------------------------------------------------------------------------------------------------------------------------------------------------------

## On the Continuity of Protoplasm through the Cell Walls of Plants.

BY W. J. BEAL AND J. W. TOUMEY,  
AGRICULTURAL COLLEGE, MICH.

Sachs, in 1863, proved the continuity of protoplasm from cell to cell through sieve plates, and in 1880 made the remarkable statement that this continuity was universal in plants. He said, "Every plant, however highly organized, is fundamentally a protoplasmic body forming a connected whole, which, as it grows on, is eternally clothed by a cell membrane, and internally traversed by innumerable transverse and longitudinal walls."\* Considering the difficulty of successfully demonstrating the continuity of protoplasm in many parts of plants, more especially

\*Walter Gardiner, in Philosophical Transactions of the Royal Society of London, Vol. 174, p. 817.

where the cell walls are thin, and with a view to finding which plants of those accessible to most students in our country are most suitable for the purpose, we began the work by examining the cortical layer of one or more species of about seventy-five genera of native and cultivated exotic trees and shrubs. Without going into details in regard to all the various methods which have been tried by Sachs, Gardiner, and others, we will merely state that at first beginning, a thin fresh tangential section was made with a razor and at once a drop of strong sulphuric acid from a glass rod was placed upon it. After one to three minutes, depending on the thickness of the cell walls of the specimen examined, the sections were rapidly washed in water, and stained with iodine or aniline blue.

Chloriodide of zinc was also tried. But the most satisfactory results were obtained by placing a thin section in a solution of iodine, until it turned brown. Then wash, and then run strong sulphuric acid under the cover-glass, and soon, again, draw out the acid, replacing it by water. After washing well, mount in glycerine and color with green or blue aniline.

In these experiments, a great deal of time and labor for weeks may here be passed over by a mere mention of the fact, calling it "dead work." Now for the results: The large masses of protoplasm in all the cells properly treated were very pronounced, and from each mass extended arms or strands in every direction. Each arm in a cell exactly approached and met or seemed to *almost* meet one from an adjoining cell. In some places, in every species examined, a continuous strand seemed to extend from one cell to the next one, but this was very likely due to some imperfect work in making the experiment. In most instances there was a light line, through which the connection could not be successfully traced. At this place the tips of the strands were swollen and between them a light, hazy look was very common.

The question to be demonstrated was the presence of delicate threads of protoplasm passing from the swollen tip of one strand to the swollen tip of a contiguous strand in the next cell. In the cells of the endosperm of palms the walls are very thick, and the space between the tips of contiguous strands rather prominent; but in the cortical layer of our woody plants the cell wall is rather thin, and the space between the tips of the strands is a very narrow one. To trace threads across this narrow passage is difficult and often unsatisfactory, as the threads are very short. We employed a Spencer's one-eighteenth-inch immersion objective.

Among the most satisfactory of the many specimens of cortex examined was that of the common lilac, where the sections were taken from large-sized twigs two to three years old. *Viburnum opulus* (snow ball) was much the same. In specimens of our hawthorns the strands were slender and longer, but the threads joining their tips showed very well. Perhaps the best one of all was taken from the cortex of *Alnus glutinosa*. Here the

strands are of good size. At the middle lamella the connecting threads of protoplasm are three to seven or more in number, and bulge outward, the whole somewhat resembling a barrel in shape. Unfortunately a drawing of the alder was mislaid. The drawing of the endosperm of *Heterospatha elata*, a palm seed (Fig. 3), has been copied from the work of Mr. Gardiner, and very closely resembles that of the alder, above referred to. In A is seen endosperm of *Heterospatha elata*, showing threads of the tips of four contiguous strands. The middle lamella is but little developed; in B, ripe endosperm of *Phoenix dactylifera* after treatment—one cell, with parts of several others. The strands of protoplasm extending out from the central mass in the cells of *Amelanchier* (Fig. 1) are often forked near the tips.

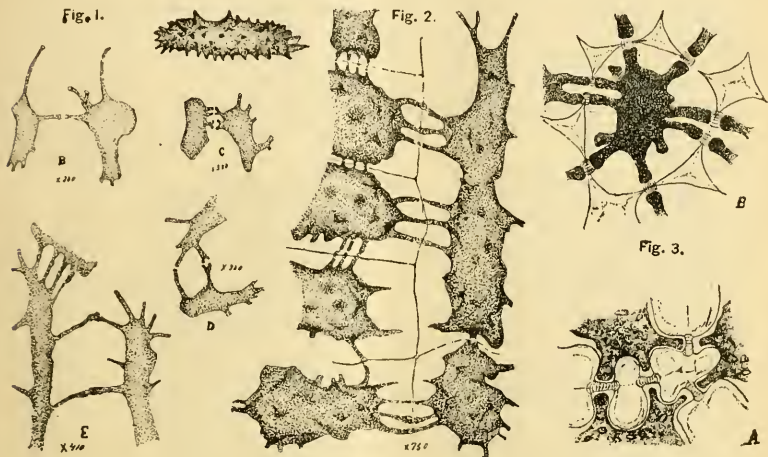

The specimen is one of the best examined. The cells are not large, but are comparatively long, and having exceedingly long protoplasmic strands. From one cell (A) many pointed strands of protoplasm seemed to radiate in all directions, their form of cells were numerous, and in some cases strands extended to other cells. The peculiar point illustrated by B, C, D, and E is the forked appearance of protoplasmic strands at the point of junction between the cells. Here in many cases the connection seems to be broken, but in above, as in E, exceedingly fine threads apparently unite the two strands. The middle lamella is easily seen in this specimen, and it is here where we always find the break, if any, in the connecting strands.

In *Crataegus* (Fig. 2) the continuity is very pronounced. The middle lamellæ are distinct. At the middle lamella there is a difference apparently in the strands of protoplasm. Strands do not appear as dense at this point as elsewhere. Strands in all

cases come to the middle lamella at the same point as those of the neighboring cells.

In the thick-walled cells of the ripe endosperm of many palms, Mr. Gardiner demonstrated that extremely delicate threads not only passed from tip to tip of the strands of protoplasm, but through the thick walls as well.

We give the names of those examined :

#### SECONDARY CORTEX.

- |                                 |                                              |
|---------------------------------|----------------------------------------------|
| Acer platanoides, L.            | Magnolia acuminata, L.                       |
| Æsculus glabra, Willd.          | Menispermum Canadense, L.                    |
| Ailanthus glandulosus, Desf.    | Negundo aceroides, Moench.                   |
| Alnus glutinosa, Gaert.         | Philadelphus coronarius, L.                  |
| Amelanchier Canadensis, T. & G. | Picea nigra, Link.                           |
| Amorpha fruticosa, L.           | Pinus strobus, L.                            |
| Berberis vulgaris, L.           | Populus alba, L.                             |
| Betula alba, L.                 | Prunus Americana, Marshall.                  |
| Betula lutea, Michx. f.         | Prunus Virginiana, L.                        |
| Calycanthus Floridus, L.        | Ptelea trifoliata, L.                        |
| Caragana arborescens, Lam.      | Pyrus malus, L.                              |
| Carpinus Americana, Walt.       | Quercus alba, L.                             |
| Carya alba, Nutt.               | Rhus capallina, L.                           |
| Castanea pumila, Mill.          | Ribes aureum, Pursh.                         |
| Catalpa speciosa, Warder.       | Ribes rubrum, L. var. subglandulosum, Maxmi. |
| Celastrus scandens, L.          | Robinia pseudacacia, L.                      |
| Celtis occidentalis, L.         | Rosa setigera, Michx.                        |
| Cladrastis tinctoria, Raf.      | Salix cordata, Muhl.                         |
| Cornus stolonifera, Michx.      | Sambucus Canadensis, L.                      |
| Corylus Americana, Walt.        | Sassafras officinale, Nees.                  |
| Cratægus tomentosa, L.          | Smilax hispida, Muhl.                        |
| Cytisus laburnum, L.            | Spiræa trilobata, L.                         |
| Dirca palustris, L.             | Staphylea trifolia, L.                       |
| Elaeagnus hortensis, Marsch.    | Syringa vulgaris, L.                         |
| Euonymus atropurpureus, Jacq.   | Thuya occidentalis, L.                       |
| Fraxinus sambucifolia, Lam.     | Tilia Americana, L.                          |
| Gaylussacia resinosa, T. & G.   | Ulmus Americana, L.                          |
| Gordonia, sp.                   | Viburnum opulus, L.                          |
| Gymnocladus Canadensis, Lam.    | Vitis riparia, Michx.                        |
| Hamamelis Virginiana, L.        | Xanthorrhiza apiifolia, L' Her.              |
| Hydrangea paniculata, Siebold.  | Xanthoxylum Americanum, Mill.                |
| Ilex verticillata, Gray.        |                                              |
| Juglans nigra, L.               |                                              |
| Lonicera sempervirens, Ait.     |                                              |
| Maclura aurantiaca, Nutt.       |                                              |

#### ENDOSPERM.

- |                        |
|------------------------|
| Iris versicolor, L.    |
| Phœnix dactylifera, L. |

—o—

**Glue Without Heat.**—Dissolve 50 parts of barium chloride in 750 parts of cold water. Put into it 13 parts of gelatine or glue. Let it stand 12 hours. Precipitate the baryta with sodium sulphate.

—o—

**Liquid Paraffin** dissolves camphor. The solution becomes perfectly limpid with a little heat



## Impressions of the Antwerp Microscopical Exposition.

BY R. H. WARD, M. D.

[President's Address at the Microscopical Section of the Troy, N. Y., Scientific Association, Oct. 19, 1891.]

### GENERAL ARRANGEMENTS.

The first general Exposition of Microscopy ever attempted would be, of itself, a most interesting event, even if it did not enjoy the rare distinction of being a tricentennial celebration of the invention of the compound microscope. Such an exposition and celebration it was proposed to hold at Antwerp, in connection with an International Botanical Exposition, in the summer of 1890; but on account of unexpected difficulties that were encountered it was not opened until last August.

A local executive committee was appointed, and the management was placed in the hands of Dr. Henri Van Heurck, the distinguished microscopist and botanist, and director of the excellent botanical garden at Antwerp. A committee of honor and patronage was also appointed, its members being selected from the various European nations, and also from Cuba and the United States.

The plan adopted, including everything fairly pertaining to microscopy, past and present, was broad enough to suit all comers, and exhibits were solicited accordingly. Unforeseen delays occurred on account, it is said, of the fact that the most important manufacturers, who were expected to furnish illustrations of the modern styles of instruments, being, in fortunate and remarkable contrast to most other businesses, already favored with demands in advance of their capacity for supply, could not well spare anything for exhibition, and did not care to incur the expense of doing so when no direct pecuniary compensation could result. Ultimately, however, the enthusiastic work and magnetic influence of the "*President Directeur*," Dr. Van Heurck, secured an ample representation of continental manufactures, and also a considerable variety of amateur and professional microscopical work.

No adequate participation was obtained from England, which country was represented by only two prominent manufacturers, and a scarcely larger number of microscopists, yet received a liberal number of the higher prizes. In America some interest was taken in the enterprise; but, with the single exception of a few notable photographs contributed jointly by Prof. J. D. Cox and an English collaborator, absolutely nothing was done. The distance would naturally increase the inconvenience and expense of participation; our manufacturers, like those abroad, seem to be fortunately above the need of exhibition as a means of increasing trade, or else they feared that the difference in prices would have prevented sufficient sales abroad to repay the expense incurred. Admitting, from a business point of view, the suffi-

ciency of these reasons, it is still impossible not to regret, as a matter of national repute if not of pecuniary profit, that we could not have been represented. We should not have hoped to compete for the first prize, as it was evident from the beginning that that must go to Jena; but with a reasonable effort we could have expected to take several in the very high grades.

Excellent local arrangements were made. The exhibit was housed in the palatial building of the Athéné Royal. Competent local agents cared for the interests of non-resident exhibitors, at a reasonable cost. The greatest courtesy was shown to foreign visitors, and unlimited opportunities were offered, to those known to be competent, for examining everything at their own pleasure. Nothing could be more unjust, according to the writer's experience, than the representations, that somehow got into print, that the articles could only be seen in glass cases.

A series of lectures, illustrated by projections with the screen microscope, was given, during the continuance of the exposition, by Dr. Van Heurck and his associates; and occasional concerts furnished entertainment to the visitors, and improved the financial situation at the ticket office.

Probably most visitors were disappointed, at first sight, at the smallness of the exhibition. It was difficult to wholly throw off the feeling that an international exposition ought to be a great affair, extending through a large number of rooms. But it soon became evident that a great microscopical exhibition need not occupy a very large space. The display grew with familiarity, until it finally presented itself as an interesting and instructive demonstration, chiefly of continental microscope, too large to be seen satisfactorily in many days, or, when seen repeatedly, to be remembered in its details as one would wish. Few persons interested in the microscope could have spent two or three weeks in serious study of the exposition without being amply repaid both in pleasure and in profit; while they would certainly have enjoyed, meanwhile, a delightful visit in the quaint and charming town.

#### HISTORICAL EXHIBIT.

Amidst the chaos of instruments displayed, a thoughtful person naturally turns first toward the historical exhibit, and especially to the one microscope of unique claims and interest, the only known original by Hans Janssen or his son Zacharias, who are claimed to have invented the instrument in or about 1590. Upon this claim rests the character of the exposition as a tricentennial, and to the memory and honor of these modest Dutch spectacle-makers the enterprise was officially dedicated in the form "To Hans and Zacharias Janssen, of Middelbourg, inventors of the compound microscope, on the occasion of the 300th anniversary of their admirable invention, the first cause of the most important discoveries in the medical and natural sciences."

The Janssens must have experimented upon a variety of forms, as was most natural under the circumstances. Their instruments have commonly been described as tubes of gilded copper, one inch in diameter and six feet long, being, probably, telescopes converted into compound microscopes, supported by dolphin-shaped pillars over an ebony base, on which rested the object to be examined. One of these is said to have been carried to England about the year 1590, and to have been shown to William Borrell and others. Very different and far more crude is the "*microscope authentique de Janssen*" contributed to the exposition by the Zealand Society of Sciences. This consists of rough tin tubes, soldered, about two inches in diameter and, when combined as a microscope, some 12 to 14 inches long, containing an ocular and objective, each consisting of a single lens of about three inches focus. It has no stand, but is held in the hands and aimed, telescope-fashion, at the object, which it magnifies from 0 to some 5 or 6 diameters, according to the extension of the tubes. Though very rudimental, roughly fitted, and to our ideas absurdly inefficient, it is still evidently a microscope, and none the less so if it was originally an experiment in telescope-making. Therefore, conceding its genuineness, which, though attacked in the interests of other claimants, does not seem yet to have been successfully controverted, and that its maker was aware of the possibility and effect of focusing it upon near objects, which is so probable as to be practically certain, this instrument takes rank as the earliest compound microscope yet known; it carries the invention back from the 17th to the 16th century, from Italy to the Netherlands, from Galileo (already rich in honors) to Janssen, and it vindicates our exposition as a tricentennial.

A cut of Janssen's Microscope may be seen in the "Cantor Lectures on the Microscope," p. 7.

The remainder of the historical exhibit presented an interesting variety of the curious and often fantastic constructions of the 17th, 18th and early part of the 19th century. Their optical parts were so primitive and inefficient as to impress one, at the present day, with great respect for the intelligence and perseverance of anybody who succeeded in doing any useful work with them. Their stands were clumsy and often grotesque, many having wooden bases and huge bodies of wood or pasteboard covered with paper or leather, and often highly decorated with chasing or paint or gilt, the whole appearance being suggestive of the cabinet-maker's and bookbinder's rather than of the optician's art; and the brass-work, what there was of it, followed the fashion of the centuries, running into scrolls and dolphin or dragon forms and ingenious elaborate devices instead of the severe practical utility of the present day. Many of the instruments were focused by screwing the whole body down with a very coarse movement, through the collar which supported it, toward the stage; a method revived in fine brass-work in the clinical microscope of Tolles a few

years ago. The chief individual exhibitors in this department were Dr. Van Heurck, of Antwerp, and A. Nachet, of Paris, both of whose collections were large and attractive.

Among the instruments most interesting for personal reasons were three genuine microscopes of Leeuwenhoek (1673), which had been used in his studies by that pioneer in histology, and were exhibited here by an artist painter (P. A. Haaxman), of Delft, a lineal descendant of Leeuwenhoek's sister; also an authentic simple microscope of P. Lyonnet, accompanied with the dissecting instruments he used with it in his famous study of caterpillars, and by the numerous plates engraved by his own hand (Maastricht, 1760), contributed by the Royal Zoölogical Society of Amsterdam; a fine compound microscope presented to Buffon by his pupils (inscribed "*à notre maître par ses élèves*") in 1758, having a wooden base with three knobs to give a tripod effect, with a stout body, some 3 inches wide and 7 long, supported vertically by heavy brass-work and supplied with coarse and fine adjustments; and a microscope by Amici, that formerly belonged to the botanist Schleiden (1837).

Of objectives, aside from the regular outfit of the various microscopes, there were globules from melted glass of 1750 and 1815; lenses of garnet and of sapphire, by Charles Chevalier (1825); and an achromatic objective by Beeldsnyder, an amateur in Holland just 100 years ago (1791). This objective, exhibited by Dr. A. W. Hubrecht, professor of zoölogy in the University of Utrecht, is claimed to be the first one made, and is so well constructed as to give a very good image. It consists of two convex lenses of crown-glass, with a biconcave of flint between them, and appears to be the earliest known adaptation of the achromatic telescope object-glass to the microscope, which was revived unsuccessfully at Modena by Amici in 1812, and successfully modified and introduced at Paris in 1823.

A most interesting example of an ancient cabinet of slides was a systematic collection of 300 preparations (18th century), in ivory slips, four specimens in a row in each; the objects were mounted in holes bored through the slips, they and their covers being held in place by wire rings sprung into the cell and upon the cover. Interesting preparations by Andrew Pritchard were also shown (London, 1825).

#### MICROSCOPES AND ACCESSORIES.

In this department the chief exhibitors were, naturally, the manufacturers, and with only two notable exceptions they were of the "continental" group.

Among the whole it was evident that one, the Carl Zeiss establishment at Jena, was easily pre-eminent, on account of the magnitude and variety of its exhibit, the high quality of its work, and the extent and importance of its contributions to the recent development of the microscope, especially in inventing and in-

troducing new optical glasses of high refractive indices and in the creation of the apochromatic objective. The exhibit included a large variety of the well-known Zeiss stands, with their different classes and powers of oculars and objectives, and their outfit of numerous and ingenious accessories; also a special stand for photomicrography, a complete special photomicrographical apparatus that is small and portable, and another of great size furnished with a Schuckert electric lantern and the most elaborate appurtenances of various kinds. But the most interesting feature of their exhibit was a demonstration of the construction of a large stand and of an apochromatic objective and a compensating ocular. All the pieces entering into the construction of a No. 1 stand were displayed spread out in a case, like a picture against the wall, each piece being given in duplicate, once in the rough casting or section of tube or wire, and again in the finished form ready for assembling into the completed instrument. In another case were superb blocks of the new optical glasses of Drs. Abbe and Schott of Jena, and of the fluorite of the Oltcheren Alp. The different stages in the construction of an 8 mm. apochromatic objective and of a compensating ocular were also displayed in proper series, all the lenses entering into the combination being shown both in the rough and the finished state. Probably every visitor would have voted with the jury in awarding the one special prize, the diploma of pre-eminence, to the Jena company.

Next to this, three grand prizes were given, which went to London, Paris, and Germany, respectively. The English one was bid for by a solitary stand, with two or three objectives and condensers at its feet, that looked so lonesome, not to say insignificant, that to claim a leading prize for it seemed almost presumptuous. Its appearance, amidst the neighboring cases crowded with showy apparatus, suggested at once the quiet home from which it came in Euston Road, in contrast with the showy shops where such goods are commonly displayed. But the stand made a strong competition for its not too modest claim, to be the most perfect that is made, the apochromatic objectives were judged to merit their high reputation, and the apochromatic condensers were found to give a singularly perfect illumination, and a "*grand prix*" was awarded to Powell & Lealand.

Prizes of like grade were well earned by, and awarded to, A. Nachet of Paris, and to E. Hartnack, originally also of Paris, but since the Franco-German war, now of Potsdam, Germany, both of whom exhibited a large variety of apparatus of the very highest grade, including excellent apochromatic objectives and sumptuous photomicrographic apparatus.

Of the many creditable exhibits of a somewhat more modest grade, at least in respect of prices, by far the largest was that of Wm. Watson & Sons, of London. In fact, it was one of the most interesting and commendable features of the exposition. It stood

alone, except for the single P. & L. stand, as the sole representative of the English ideas and styles, while everything around it was continental, wholly continental. These makers, also, in developing some of their most practical stands, have made such large and good use of American ideas and experience that we are half inclined to claim a special interest in the result. We have been much interested in their efforts during recent years to develop and improve the simple and less expensive forms of microscopes, especially in rendering the English and American type convenient and available for laboratory use, and in building up in London well-organized shops (after the method characteristic of American practice) where work of a uniformly good quality can be done by machinery at a moderate cost. Perhaps the most universally available of their more ambitious instruments, though fortunately far from the largest or most costly, is the one lately arranged from Dr. Van Heurck's suggestions and named after him. Though of moderate size and cost, being of exactly the size that the writer would choose as a maximum, this possesses a great number of serviceable features; and, notwithstanding the unfavorable opinions that some eminent authorities have expressed on theoretical grounds, its practical working seems excellent. The jury especially complimented "the extreme precision of all its movements;" and the writer found it unexpectedly easy with its fine adjustment to focus a lens of n. a. 1.63 upon the shell of *A. pellucida*, adjusting it instantly to exactly the plane of clearest vision of the dots, and leaving it there, though every one knows that, with extreme powers, it is often easy to catch glimpses, in passing, of points which can hardly be permanently focused upon and shown to other observers.

One of the strongest and most agreeable impressions made by the manufacturers' exhibit, in the aggregate, is that of the uniformity in good workmanship, and of the variety of convenient and tasty designs, by all the prominent makers.

All the manufacturers, with two exceptions, already stated, are of the continental sort, and never before has the writer seen grouped in one room a representative collection of their microscopes at all comparable to this. It is most interesting to note the purity in which, in so many hands, their type of stand has been preserved and the extent to which its possibilities have been developed. This style must be abundantly satisfactory, alike to the manufacturers and to their patrons, to be so freely reproduced and elaborated by so many ingenious workers, in so many diverse places, with so little deviation from the prevailing type. The interest of the display is doubled, to Americans, from the fact that from the first we have been constantly presented with the choice between adopting the English or the continental style as the basis of our own. The friendly though often severe battle of the stands has continued throughout the memory of the present generation, and still continues to some extent notwithstanding the

evident fact that the English type has entered by far the most largely into our experience thus far. Without forgetting that where the wisdom and experience of continents are concerned, the opinions of single individuals are of little importance, the writer could not do justice to the title of this paper without giving his "impressions" on this very interesting phase of the subject. While a user of the English style for more than thirty years, and naturally with strong prepossessions in its favor and still satisfied with it, he must admit that the neat and unpretentious continental stands of the smaller and more simple grades become more attractive with every increase of acquaintance. It would be difficult to find anything more tempting or practical for student's laboratory work (exclusively) than the beautiful little stands exhibited by all the French and German makers, though some of the small American and English stands still seem to be equally available. On the other hand, the larger stands of the continental type, with elaborate adjustments and numerous accessories, always produce the feeling that, notwithstanding their ingenious designs and great efficiency, they are unfortunately clumsy and somewhat overloaded, their traditional compactness being maintained at the cost of some unnecessary inconveniences. The possibilities of the English-American stand seem to be not yet realized on the continent; but the writer will venture the prediction that there will be a revolution in this respect some time before the next tricentennial. The reaction has evidently commenced already in respect of accessories and incidental refinements of detail. Such microscopical aids and comforts as mechanical stages, elaborate sub-stages and sub-stage condensers, iris diaphragms and rapid nose-pieces, which we have been using for a generation, more or less, with great satisfaction, but which we have meanwhile heard constantly denounced by partisans of the continental method as needless luxuries and distracting toys, all these we now see introduced and given a proper prominence by the best continental makers. 'Tis well.

As to objectives, the progress of the present day evidently centers around or stands in comparison with, the apochromatic system. Of the success of the system there is no longer a reasonable doubt, either as a scientific or as a commercial question. Characterized by the employment of new varieties of glass, of extraordinary optical properties, manufactured at Jena, and by the substitution of fluorite (natural fluor spar) for crown-glass in several of the lenses, it corrected spherical and chromatic aberration to an extent not before attained. Brought into existence by the researches and experiments of Abbe and Schott, and first successfully introduced at the Zeiss factory, in 1884, it is now adopted for their highest grades of objectives by all the above-named makers, except perhaps Watson; and new series or varieties are being constantly introduced.\* The resolution of *Amphipleura pellucida*

\* Near the close of the exposition, after the report on awards was adopted and closed, a new 1-12th (2 mm.) was received from Nachét and informally examined by the jury, with the result of calling out from them a special note of commendation.

in dots, which has been ably disputed and may be still doubted by some competent judges, is well within the limit of their capacity. The writer was fortunate in being afforded the rare privilege of witnessing the official trial of the objectives by the jury, at which time the Zeiss 1-10th (2.5 mm.) of n. a. 1.63, with monochromatic sunlight illumination, showed the dots (or "beads") with beautiful distinctness and with perfect ease. They were seen at a glance over a large part of the shell at once, always alike and with remarkable freedom from any suspicion of uncertainty; and when lost by change of focus, or even by carrying the instrument to another table and readjusting the light, they could be recognized instantly, and every time, by simply correcting the fine adjustment. As the most oblique pencils able to be utilized by this objective, as employed, ought, according to the Helmholtz theory, to be able to resolve lines of about 6,000 to the millimeter, and as the *A. pellucida* had about 3,700 rows of the dots transversely, and 5,000 rows longitudinally, to the millimeter, this resolution, while near enough to the theoretical capacity of the lens to give an impressive demonstration of a near approach to perfection in the construction, yet does not, by exceeding its theoretical capacity, throw discredit upon either the genuineness of the resolution or the accuracy of the optical theories involved.

But the durability of the apochromatics is, most unfortunately, not equally plain. It is said that those first made were unsafe, from the ease with which changes occurred in the frail phosphate and borate glasses causing the dimness known as the disease of the apochromatics. This was always freely corrected without charge by the makers, and it is believed that the glass as now made is free from this defect. The fluorite, however, must be taken with its natural defects; and its easy cleavage renders it very fragile. In fact, it is now known that, more than thirty years ago, Charles A. Spencer, of Canastota, N. Y., recognized its tempting optical properties, and used it in the construction of objectives, one of which is still in existence; and that he abandoned the method because of the early deterioration from the cracking of the spar. That now used in the apochromatics is not only clearer and remarkably free from color, but is evidently more durable, and, it is hoped, practically permanent. The lenses are, however, absolutely limited in output, as the world's supply of suitable spar is confined to the stock now in hand, with no known means of replenishing it. It is, therefore, none too soon to be finding some method of making high-class work without it; and this is being attempted, with encouraging success, by several makers, in the construction of the semi-apochromatics, made from the new optical glasses, but without the fluorite. Though not quite as free from color as the apochromatics, their views are very distinct, and their working qualities extremely good. The resolution of *A. pellucida* in "beads" by a semi-apochromatic is claimed to have been accomplished in Italy.

(To be continued.)



## An Interesting Study of Living Micro-Organisms.

By HENEAGE GIBBES, M. D.

ANN ARBOR, MICH.

A very instructive investigation into the life-history of some of the micro-organisms may be made at this time of year with little trouble. Obtain a lump of frog spawn, about the size of the fist, from any of the stagnant pools where these animals live and place it in a glass jar containing about eight or ten gallons of river water. A glass jar suitable for the purpose can be arranged by taking a large bell glass or shade having a knob at the top, such as are used to cover plants, and getting a round piece of wood turned with a hollow in the centre to receive the knob of the glass jar. It can then be inverted in the piece of wood, and, when filled with water, will be perfectly steady. The glass of which these bell shades are made is quite thick and well able to stand the pressure of the water. There are other forms of glass jars that will do equally well, but the above is the most inexpensive. Fill the jar nearly full of water and place the frog spawn in it. If it is living it will float level with the surface of the water. The jar should be placed where it can receive full light all day, but not direct rays from the sun. After a few days the small black specks in the eggs will be noticed to be changing their shape and becoming elongated, and this will go on until a number have left the spawn and have attached themselves to the sides of the glass as small tadpoles. This will go on until all the eggs that are fertile have given forth tadpoles and hundreds of the little animals are seen sticking to the sides of the glass. For the success of the experiment it is necessary that the spawn and water should be placed in a clean jar and not in one where water has been standing for some time and a growth of algæ has begun on the sides of the jar. Before all the tadpoles are hatched out, if they are in large numbers, the oxygen in the water will have become exhausted, and if no water plants have been placed in the jar they will all die. This is the result that is wanted, and therefore no plants must be placed in the water. On carefully examining the water from day to day it will be noticed that when a large number of tadpoles are clinging to the sides of the jar, although all are not hatched out, a faint milky tinge will be seen in the water; this rapidly increases; at the same time the frog spawn falls to the bottom of the vessel and all the tadpoles die.

Now take a small drop of the water and examine it under the microscope. It will be found to be teeming with countless numbers of a large spirillum. These resemble two spirals of a corkscrew and are all in rapid motion, going round and round as they move across the field of the microscope. A few other forms will be found, such as infusoria, but the spirilla outnumber them by thousands to one. In some cases a smaller and more slender form

is found with the large ones. The water should be tried every day, and it will be found that in two or three days the spirilla will become fewer and then will disappear altogether, their place being taken by some other form, generally a bacillus. These bacilli will live for a few days and will then be replaced by some other form, and so on until micrococci appear, which form zooglea, and grow as a scum over the surface of the water.

This seems to me to be a most instructive study in the life-history of these minute organisms—their rapid appearance when the frog spawn had lost its vitality from want of oxygen, and the enormous rapidity with which they increased from spores, which must have been in the water waiting for a suitable pabulum on which to exert the functions for which they were created. Then, when they had passed through their life cycle and produced by their digestion of this devitalized organic matter a suitable condition for the next form, it at once began to develop from the spores present and increase and in its turn produce a state of things suitable for the next form, and so on.

At the present time, when the relation of micro-organisms to diseases is exciting so much attention, it seems to me that any work done on the subject must help us to understand the part these minute structures play in the animal economy. We must remember that great changes have taken place in the opinions of even the most rabid bacteriologists, when a year or two back one germ was considered to be the virus of typhoid fever. The Hygienic Congress in London last year brought out the fact that about thirteen forms were so intimately associated with this disease that no single one could be accredited with that honor. The same with pneumonia, and now the awful bacillus of tuberculosis, for whose destruction in dry sputum and elsewhere such elaborate arrangements have been advocated, has been proved by a Japanese working in Koch's laboratory to be dead both in sputum and in cavities. This, all who have been working on the subject have known, but could not absolutely prove. In the face of all this, we can hardly take up a medical or scientific paper without finding some allusion to the bacillus of this or that disease. The comma bacillus of cholera is frequently spoken of, although ten distinct forms have been isolated from cholera patients in India and proved to have no causal relation to the disease. Let any one having time and experience take this question up that I have indicated and thoroughly work it out, and I think he would be able to throw a good deal of light on this question of bacterial action.

I may say that the large spirilla make most beautiful slides for the microscope, and when well stained their flagella form splendid test objects for high powers, and also for the skill of the microscopic photographer. Full details for staining, mounting, and photographing them will be found in my work on Practical Pathology and Morbid Histology, published by Lee Bros. & Co., of Philadelphia.

**Radiolaria: Their Life-History and Their Classification.**

BY REV. FRED'K B. CARTER,

MONTCLAIR, N. J.

[Continued from page 64.]

The material is now ready for examination. But let no one imagine that this is the work of a moment. My impression is that less care is taken in the case of the Radiolaria than in that of almost any other class of microscopic objects which might be mentioned.

In a dozen years I have seen hardly more than a dozen slides of polycystina exhibited. Search among the cabinets of amateurs and you will find that while they are overstocked with diatoms there are scarcely any slides at all of polycystina. I asked a friend of mine to bring me all the slides he could find of these forms in an unusually large and fine collection of microscopic objects, and he brought me just four. Yet I am sure that the slides of diatoms and the histological slides in that collection must run up into the hundreds. And what of those four? Three were *opaque* mounts, and in one of these the forms were mounted in such a deep cell as to be beyond the reach of an ordinary  $\frac{1}{4}$ -inch objective; only one was mounted as a transparent object and that was a slide of *moving* polycystina, utterly useless for close examination with a high power. But the reason is perfectly plain. As a rule no one thinks of observing them closely or with a high power. At least that has been my experience, for I never saw any of them under a power higher than a half-inch until I began to make a definite study of them for myself. They are regarded as simply pretty opaque objects, to be displayed with the binocular and the  $\frac{3}{4}$  or  $\frac{1}{2}$  inch; to be viewed *as a whole* for a moment or two and then cast aside in favor of some other interesting object. Of course, for show objects, two or three slides are as good as a hundred and the amateur sees no reason for owning more. And in fact he cannot get any variety if he would from the dealers on this side of the water at least. It is rare to meet with a slide for sale from any locality but Barbadoes. I secured one from the Nicobar Islands, but it was the only one the dealer had, and I do not remember ever to have seen another for sale from that locality, and while there are plenty from Barbadoes they are apparently all alike, at any rate so much so that one is not disposed to purchase many at half a dollar apiece. But they are not all alike. One slide will have several forms not on another, and while they are too costly to buy by the dozen, what is to hinder one from making up a couple of dozen of strewn slides of his own, or from picking out the different forms and mounting them separately? They are no harder to pick out than diatoms, and many an amateur has become expert enough for that. Let him go to work at the Barbadoes earth and he will be surprised to see what a variety there is in that deposit as he mounts one after another. If he is at all thorough about it

it will afford him occupation for a long while, for Ehrenberg found no less than 282 species, and Mrs. Bury added to this large list 141 more, while Haeckel says that the total number of species in that deposit alone is probably over 500.

But whether one mount them separately or not let him not be content until he has *practically* isolated each form by using a power high enough to shut out almost all the other forms from the field of view. Begin with the binocular and dark-ground illumination, by means of the Abbe condenser, and carry the powers up to 1-4th, 1-5th, 1-6th. Then use direct light from a flat wick, *dispensing with the mirror* and using a binocular diaphragm, or, in case of a 1-4th, 1-5th, or 1-6th obj., a diaphragm with round opening just large enough to fill with light the back lens of the objective, as may be ascertained by removing the eye-piece and looking down the right-hand tube after shutting off the light from the left, and by all means *diffuse* the light. For this you can use ground glass in your diaphragm ring, but there is something equally good, if not better, which you can make for yourself for nothing. Take a thin piece of mica and rub it on both sides with emery paper in two directions at right angles to each other. The result is a fine mat surface, and this will prove just the thing to bring out the forms with remarkable stereoscopic effect.

Then when you have finished with the binocular examination take the *monocular* tube and proceed as before, first with dark-ground and then with direct illumination, and go on up from the 1-2 to the 1-4, 1-5, 1-6, and even 1-8, using every now and then your diaphragm of mica to diffuse the light, for it often brings out minor points beautifully. If you have never tried these higher powers on the polycystina you will be astonished and delighted at the beauty and variety of markings as so displayed, and when I tell you that all of Haeckel's figures are drawn under a power of at least 300 diameters and many of them of 400 diameters you will admit that there is good reason for what I urge, or, if not, a glance at the figures themselves will speedily convince you, if you are fortunate enough to get a peep at them. They are simply exquisite, and there is no end to the variety in the plates of that magnificent work. I began this investigation without knowing anything about the polycystina, beyond such a superficial knowledge as is to be obtained from opaque mounts. But I soon became enthusiastic, and I am confident you will also. And you will surely say to yourself, as I have said, why in the world do not preparers put up separate forms of the polycystina as they do of the diatoms? Why cannot one buy type-slides of them? I see by the catalogue of Möller's diatoms that he has one slide of 72 forms of the polycystina, but they are mounted opaque, which is not the best method for close study, and the catalogue does tell whether he ever made more than one. In fact, as I understand it, none of those slides are now in the market, nor will they be

until after they have been exhibited in some of the principal cities of Europe and of this country. If some of our diatom experts would only put up such slides of some of the most beautiful forms of the polycystina, I am sure they would find a ready sale. I have a slide with just one specimen of *astromma* on it, put up by Mr. Geo. B. Scott, and it is "a thing of beauty and a joy forever." never failing to call forth admiration. It happens to be quite a large form, and here let me say that the Radiolaria vary considerably in size. I have just measured a dozen or so of them and find that the round forms, spheres, or disks, range from 1-85th to 1-300th-inch. This, of course, is without taking into account the spines, some of which are as long as the diameter of the main skeleton and even longer. In the conical forms, the long diameter, exclusive of appendages, horns, or feet, ranges from 1-90th to 1-400th-inch, while the double forms have a length of from 1-400th to 1-700th-inch. *Histiastrum*, including the arms, measures 1-45th inch.

(To be continued.)

---

## EDITORIAL.

---

**Proceedings of the American Society of Microscopists.**—The meeting of this society for 1891 was held in Washington ten months ago, and at this writing the volume of proceedings is not yet out. The rules require that every paper shall be in the hands of the secretary at the close of the meeting in order to facilitate prompt publication.

Those members who do not know what an immense number of details are involved in the publication will be inclined to consider such delay as unnecessary. They are mistaken, excepting on the supposition that a secretary is going to drop all his other occupations and do nothing but hurry through such a volume. Even then, half the time is required and much experience.

A publishing house, with many facilities not enjoyed by individuals, and devoting itself energetically to the task, would require several months in which to get out a volume like the proceedings.

The extent to which a secretary must trench upon his personal interests and private enjoyments in order to put through such a volume is far greater than the members realize. It is worth \$500 in hard cash to do it, and the secretary ought to be credited by the treasurer with a donation of that sum to its exchequer. Of course he would also enter payment of \$500 for the services in order to balance his accounts. But the members should feel that even with the delay they are deeply indebted to the secretary. The present is the second or third volume which Professor Seaman has edited. We beg to submit that at the coming meeting

it will be fair to assign to him the highest honor within the gift of the society instead of again entrusting to him this burden which he so willingly and so patiently bears. And, further, it is suggested that his successor ought either to understand that he will also be honored in due time as a return for his labors, or else a salary of at least \$500 should attach to the office. The American Association for Advancement of Science pays its secretary \$1,500 in addition to giving him the services of a clerk the entire year. Let the microscopists make some return for such services and not complain of delays even after having done so.

As to still further enlarging the proceedings and issuing periodical numbers so as to bring out a part only of the papers with more promptness, we shall have little to say. Probably it would be inferred that whatever we might say was due to a dislike for the competition of a new periodical. But before the society decides to set up a microscopical periodical in place of its annual proceedings it would do well to consider many phases of periodical publishing of which it is now ignorant and to listen to the views of men who have actually had experience with periodicals in other than microscopical lines, since the same facts and opinions are applicable here.

### MICROSCOPICAL MANIPULATION.

**Poisoning Protoplasm with Quinine.**—Quinine has been found to destroy amœboid movement. Quinadine has  $\frac{5}{8}$  the poisoning power of quinine.

**To Prepare Lignite.**—Macerate in carbonate of potash for several days; cut thin sections, heat them in a watch-glass until they turn yellow, drop them in cold water, mount in glycerine.

**Transparent Cement.**—Take 10 drachms gum dammar, 6 of gum mastic, 6 of dried Canada balsam, 2 fluid ounces of chloroform, and the same of turpentine; shake until dissolved, and filter.

**Using Oil-immersion Objectives.**—In using these objectives cleanliness is important. Only a small quantity of the immersion fluid (specially prepared cedar oil) should be used, and it should be wiped off as soon as possible when done using.

To remove the oil, blotting-paper should be used, and then, breathing on the front lens, wipe it lightly with a piece of clean, soft linen.

In order to keep the immersion fluid unchanged it should not be exposed to the air for any length of time, as exposure to the air will thicken it, and so alter the refractive index.—*E. Penock.*

**Preparing Sponges.**—W. R. Melly reported to the British Association (1891) the following solution for killing sponges extended:

96 per cent. methyl alcohol . . . . .	10 parts
Salt water . . . . .	90 "
Natrium chloride . . . . .	$\frac{6}{10}$ "

He places the specimen in a glass jar (2 x 1 inch) filled with water. Then add the solution, putting in one drop per minute; if not retracted after 45 minutes, pour on quickly some hot sublimate; in this way some specimens are secured half-retracted. To preserve specimens for sections put them in 1 per cent. osmic acid (for 2 minutes), and then successively in 5, 10, 20, 30 per cent. alcohol up to 90 per cent.; harden in absolute alcohol and imbed in paraffine; stain with borax-carmin and hæmatoxylin.

### BIOLOGICAL NOTES.

**Teaching with the Microscope.**—Professor Leviston well says that the teacher who attempts physiology without a microscope is to be blamed for leaving his pupils in the dark about the most vital principles; that botany without illustrations of cell growth is a mere fiat study; and that a child six years old may begin to use a simple microscope as a plaything.

**Weed Extermination.**—Moses Craig, of the Oregon Agricultural Experiment Station, has issued a bulletin containing pictures and descriptions of the common weeds of Oregon, with practical directions for destroying such weeds. This is an excellent illustration of the good which farmers are now getting out of biology. Send to Corvallis, Oreg., for a free copy.

**Effects of Electrocutation.**—After the execution of Kemler it was thought that certain changes had been produced by electricity in the cells of the body, but since the more perfect use of this mode of execution the most complete study of the microscopic appearances indicates that none of the tissues are appreciably injured by the shock. The lethal current of from 5 to 7 amperes, with voltage of 1,500, destroys life, but mutilates not a single cell.

**How Seal-skin is Prepared.**—If we look at a lady's seal-skin jacket, we at once observe its rich brown color, and the velvety softness and denseness of the fine hairs composing it. If this be compared with the coarse, hard, or salted dry seal-skin as imported, or, still better, with the coat of the living fur seals, one is struck with the vast difference between them, and wonders how the coarse or oily-looking, close-pressed hair of the live animal can ever be transformed into the rich and costly garment above spoken of. Passing our finger among the hairs of the cat or dog, we may notice short fine hairs at the roots of the longer, coarser, general covering of the animal. This is the so-called under-fur. It equally obtains in most of the land as in the aquatic carnivora.

But in the greater number of these animals the short hairs are so few and often fine as to be, comparatively speaking, lost sight of among what to our eyes constitutes the coat. The remarkable feature, then, in the fur seals is its abundance and density. The operation which the skin undergoes to bring out, so to say, the fur may be briefly described as follows: The skin, after being washed rid of grease, etc., is laid flat on the stretch, flesh side up. A flat knife is then passed across the flesh substance, thinning it to a very considerable extent. In doing this the blade severs the roots of the long strong hairs which penetrate the skin deeper than does the soft delicate under-fur. The rough hairs are then got rid of, while the fur retains it hold. A variety of subsidiary manipulations, in which the *pelt* is softened and preserved, are next gone through. These we need not enter into, but only further state that the fur undergoes a process of dyeing which produces that deep uniform tint so well known and admired. We may, however, mention that it is the dyeing process which causes the fur to lose its natural curly character and to present its limp appearance.—*From Cassell's "Natural History" for June.*

---

## DIATOMS.

---

**What are Diatoms?**—The plants in question are so small as to be seen only with the aid of the microscope; those of ordinary size, when magnified about three hundred and fifty diameters, appear about a quarter of an inch long. Others are much larger. They are curious little plants with a silica shell, which, in certain places, is provided with little apertures through which living parts of the plant protrude. In this way they are enabled to move about freely in the water by which they are generally surrounded, for, though they are not all strictly water plants, they all need considerable water to enable them to thrive, and so are always found in wet places.

Owing to their freedom of motion they were at one time supposed to be animals. Now it is known that they are plants, as they can perform all the functions of plants, and no animal, with all his superiority, high nature, etc., is able to do this. They are found everywhere in all inhabited countries, and in fact all over the seas, so it may be readily granted that a plant so common and wide-spread as this should be quite familiar to every one.

Again, not only are the living plants so wide-spread and common, but the shells of the dead ones remain intact for many years; and in certain localities these tiny shells are so numerous as to form a large portion of the soil. Some of the best known of these localities are the sites of Richmond, Va., and Berlin, in Germany.—EMILY L. GREGORY, in *The Popular Science Monthly for June.*



**Cleaned Material.**—Cleaned diatomaceous material is sold by M. J. Tempère, 168 Rue St. Antoine, Paris, France, who at intervals of about three months issues a series of twelve tubes of cleaned diatoms in liquid, each tube holding about one-half of a drachm.

---

## MEDICAL MICROSCOPY.

---

**Microscopy for the Druggist.**—A great awakening to the subject is taking place among the druggists of the West. The Kansas State Pharmaceutical Association now has a section of microscopy. Not only the young druggists but the older ones are enthusiastic over the practical results to be attained. The attitude of Dr. Whelpley, editor of the *Meyer Brothers' Druggist*, has been perhaps the most prominent factor in bringing this about. He has been elected an honorary member of the Kansas Association. The Griffith Club microscope seems to be in especial favor among the members.

**The Clinical College of Medicine and Specialty Hospital.**—The new Medical College and Hospital in Chicago will have a department of microscopy and histology, and the directors are now receiving applications for the position of demonstrator. The requirements for admission to this college will be high and everything be done in first-class style.

**Sweating.**—It has recently been shown that microbes of quite a number of diseases are eliminated in sweating and it is believed that in several diseases this is the chief means by which the system rids itself of these injurious organisms. Brunner sterilized the skin of animals and then produced in them *anthrax*, *micrococcus prodigiosus*, and *staphylococcus aureus*. In each case he found the microbes in both sweat and saliva. It is believed that if such infected sweat is not washed off promptly, the microbes are liable to be reabsorbed. Hence, a new and urgent reason for cleanliness and for a frequent change and disinfection of garments in case of infectious diseases.

**Pasteur Institute.**—At 178 W. 10th st., New York city, is a Bacteriological Institute, under the direction of Dr. Paul Gibier, for the preventive inoculation of hydrophobia patients. During its second year, ending Feb. 18, 1892, it treated 574 persons who had been bitten by dogs, cats, or other animals, but 461 of these cases were not actually hydrophobic. Three persons who had been treated nevertheless died of hydrophobia, but it is estimated that seventy would have died had none been subjected to this kind of treatment. The report (of four pages only) is interesting.

## MICROSCOPICAL NEWS.

**A Silver Medal for Dr. Taylor.**—In its report just announced, the Jury of Awards of the International Exposition at Paris, 1889, has awarded the grand prize to the U. S. Department of Agriculture for "Organization, Methods, and Material for Agricultural Instruction."

In the award, Professors W. O. Atwater and Thomas Taylor are particularly distinguished: Professor Atwater for his exhibit of maps and photographs of agricultural colleges, and Dr. Taylor, microscopist, for his collection of photographs and drawings of the microscopic analysis of food adulterations, especially butter.

Each of these gentlemen is awarded a silver medal.

**An Electric Microscope.**—A microscope has been made in Munich, Germany, at a cost of \$8,500, for the World's Fair, which, setting aside its great power and scientific value, is remarkable for the number of electrical adaptations that have been employed to increase its efficiency. Electricity not only furnishes and regulates the light which, placed in the focus of a parabolic aluminum reflector, reaches an intensity of 11,000 candle-power, but provides an ingenious automatic mechanism for centering the quadruple condensers and illuminating the lenses. The distance of the carbon point is controlled by the same means.

The most wonderful feature of the instrument is, however, the cooling machine. The intense illuminating power naturally produces extreme heat, and this is modified by a machine which provides the microscopic and polariscopic systems of the apparatus with a fine cooling spray.

This spray is composed of carbonic acid which, when released from a copper vessel in which it is held under very high pressure, is converted into gaseous matter so intensely cold that only .00007 gram of the acid per second is required to produce the result. With the ordinary objectives the magnifying power of the instrument is 11,000 diameters.—*Electricity*.

**E. H. Griffith**, the inventor of the Club microscope, sends us an account of the marriage of his daughter, Mary Josephine, to Rev. Robt. Rabb, of Monticello, S. C., May 20, 1892. Mr. Rabb is to be pastor of the First Baptist Church at Eugene City, Oregon.

In Austria the pharmacist is compelled by law to keep a microscope in his store.

**Bausch & Lomb's New Buildings.**—The largest of the new buildings will be 185 feet on the Vincent place, or south side, 80 feet on the east, 53 feet on the west, and 162 feet on the north, and will be five stories in height, including the basement. Between this and the present buildings, and coming a little in front of them, will be a handsome new engine-house 64 feet by 40 feet and 22 in height, with a very wide, massive stone entrance

in front and a trussed glass roof. Immediately back of the engine-house is the boiler room, 40 feet by 60 feet, with room for four boilers, coal bunkers, etc., and back of this again will rise the large new chimney 130 feet in height. Over the rear part of the engine-room will be built a four-story connection between the old and new factories, 33 feet by 40 feet in size, and of a design to harmonize and unite the different styles of buildings. The engine-room will contain a fine new Harris-Corliss engine of 400-horse power, built especially for the Company, and through the room, and half way to the ceiling, will be a passage or walk where visitors in passing through to the new factory may see the working of the engine from above.

The new factory will contain a large elevator and two fire-proof stairways entirely separated from the floors by thick brick walls. The heating will be done by a large blower forcing fresh warm air into each story, and the most improved methods of ventilation will be employed, entirely independent of the windows. Every room will be equipped with automatic sprinklers, and the plumbing will be of the best appliances. The buildings will be lighted by electricity from the Company's plant of two 400-light Edison dynamos, the power of which is given by a separate 100-horse power engine.

The cost of the works which are now being constructed will be about \$50,000.

---

### CORRESPONDENCE.

---

I think your determination to enlarge and illustrate the JOURNAL, a wise one. I read it with much interest and profit.—*W. W. Rowlee.*

I am pleased to hear that you intend to increase the size of the JOURNAL next year. The increase of interest which this will enable you to give the JOURNAL will no doubt amply repay subscribers for the increased cost. The price will still be low for a journal of its scope and character.—*S. W. Cochran.*

For my part, I would not object if the price were tripled.—*C. E. Stoner.*

Be sure to find me a subscriber at \$2, or, if it need be, even at \$3, per year, as the magazine is not only a recreation but a real use to me.—*P. W. Gayer.*

---

### MICROSCOPICAL SOCIETIES.

---

WASHINGTON, D. C.

*134th Meeting, Mar. 1, '92.*—Dr. Alleger read a paper on Methods of Preserving and Mounting Urinary Deposits and exhibited some slides. A committee was appointed to arrange for the annual soiree.

*135th Meeting, Mar. 15, '92.*—The feasibility of incorporating the society was discussed. The society appropriated \$15 for purchase of slides. Dr. Blanchard presented some wood sections ready for mounting which were distributed among those present. Dr. J. M. Lamb read a paper on the Demonstration of Some Histological Subjects.

*136th Meeting, April 5, '92.*—Two new members were elected. Dr. Blanchard read a paper entitled "Specimens from *Cuscuta*." He illustrated it with slides.

*137th Meeting, April 19, '92.*—Dr. Seaman made some remarks on micrometric rulings. A bull's-eye condenser was ordered.

SAN FRANCISCO, CAL.—WM. E. LOY, *Sec'y*.

*March 16, 1892.*—President Breckenfeld announced as the principal feature of the evening a paper entitled, "Some of the Practical Bearings of Bacteriology in Its Relation to Hygiene," and it was illustrated with numerous cultures, preparations, and apparatus.

Mr. Breckenfeld exhibited a beautiful and interesting fresh-water polyzoan, a species of *Fredericella*, discovered in Mountain Lake by George O. Mitchell.

THE ST. LOUIS CLUB OF MICROSCOPISTS.

*May 5th, 1892.*—Met at Dr. H. M. Whelpley's rooms by invitation; ten members present. The treasurer's report showed all dues paid up and the society to be in fine financial condition. Dr. Whelpley exhibited and explained a microscope made a century ago by Spencer. The workmanship was excellent and the defining power good. Curator reported the receipt of a valuable slide from Mr. J. E. Huber, Peoria, Ill. Dr. H. M. Whelpley is to be married to Miss Spannacle, of St. Louis, about the 29th of June.

## NOTICES OF BOOKS.

*The Prevalent Epidemic of Quackery.* By Geo. M. Gould, M. D. Medical News Co., Phila. Pp. 24.

This is a very spirited little pamphlet, and contains an address delivered at Buffalo University May 3, 1892. The following paragraphs are characteristic:

"Convinced that people need simple instruction honestly put before them, I wish to have a little pamphlet prepared to show up the ridiculous pretensions of modern homœopathic practice. I offer a prize of \$100 for the best essay on the subject."

"What a disgrace that patent-medicine syndicates can draw many millions every year from the people, with a governmental tax of only 25 per cent. upon their mixtures, while the same people must pay a tax of 60 per cent. upon microscopes and one of 49½ cents a pound, and 60 per cent. besides, on woolen clothing."

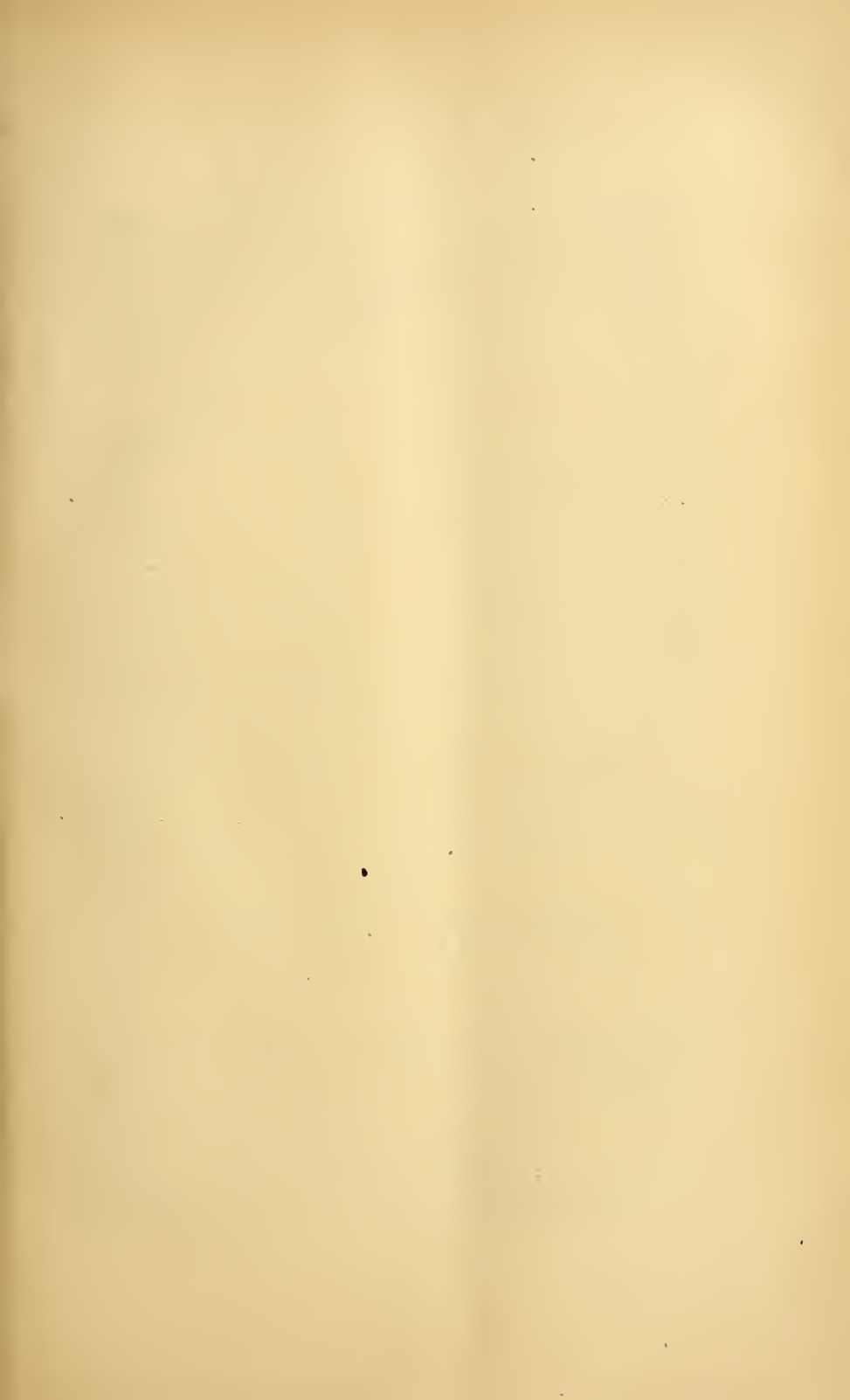

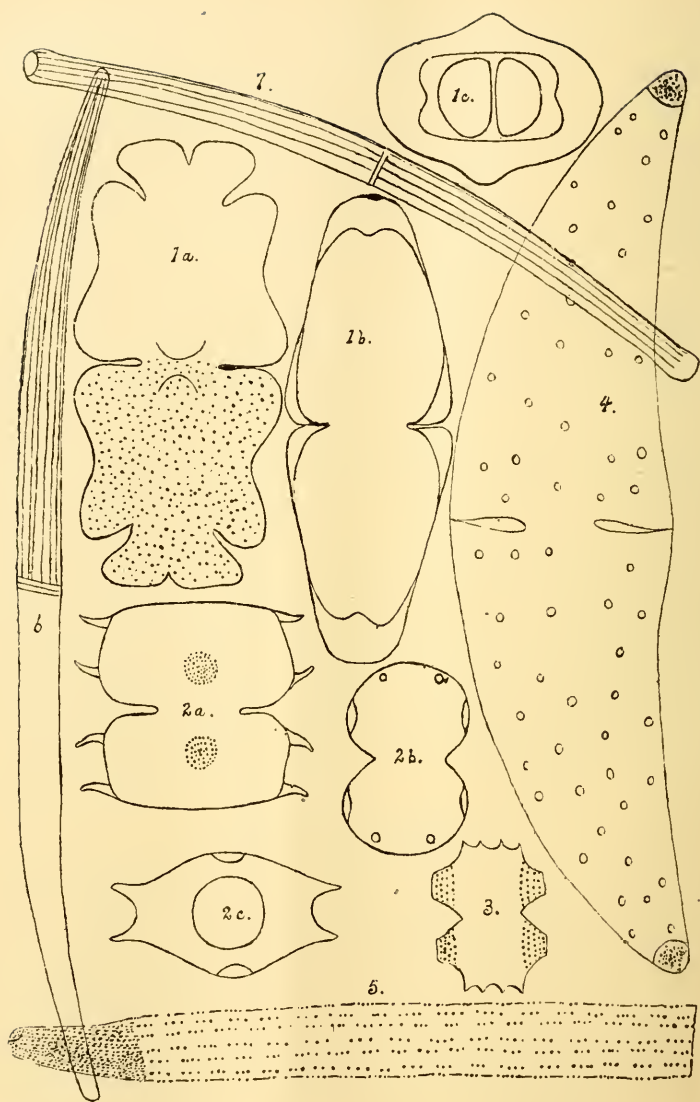

SOME NEW DESMIDS.

# THE AMERICAN

MONTHLY

## MICROSCOPICAL JOURNAL.

VOL. XIII.

JULY, 1892.

No. 7.

### CONTENTS.

New Desmids From New Hampshire.—I (Illustrated).—HASTINGS - - - - -	153	BIOLOGICAL NOTES.—Circular Growth of Fungus - - - -	169
Microscopical Illustrations.—TOLMAN - - - - -	155	DIATOMS.—The Mobile Deposits.	169
Impressions of the Antwerp Microscopical Exposition.—WARD	157	BACTERIOLOGY.—The Examination of Sputum for Tubercle-Bacilli. Biedert's Method. Gabbet's Staining Process. For Cover-Glass Preparations.	170
EDITORIAL.—Priority in Giving Scientific Names. The Science Meetings - - - - -	163	OBITUARY NOTICES.—Dr. L. D. McIntosh. Dr. Justin R. Hayes - - - - -	172
MICROSCOPICAL APPARATUS.—The Lane-Sear Microscope Lamp (Illustrated). A Box for Slides (Illustrated). A Pressureless Mounting-Clip. A Cheap Camera. To Arrange a Photomicrographic Dark Room - - - - -	165	MICROSCOPICAL NEWS.—Leidy's Microscopes. H. L. Tolman. The Key to Algæ and Desmids. Prize - - - - -	174
MICROSCOPICAL MANIPULATION.—Collecting Terrace Dust.	167	KORRESPONDENCE - - - - -	175
		MICROSCOPICAL SOCIETIES.—San Francisco - - - - -	175
		NOTICES OF BOOKS - - - - -	176

### New Desmids From New Hampshire.—I.

By WM. N. HASTINGS,

ROCHESTER, N. H.

WITH ONE PLATE.

Diagnoses of the following desmids have been published in a local newspaper. The dates affixed give the date of such publication.

*Euastrum magnificum*, *var. crassioides*, *var. nov.*, Wolle. (Plate 1, fig. 1a, 1b, 1c, x 500.) This may be most concisely described as intermediate between *E. magnificum* (Wolle) and *E. crassum*. In end view it is nearly like the first, but in this view the intermediate lobe is rounded, not "notched." In lateral view this lobe is notched, and the central inflation is seen to be most

prominent near the base of the semicell, its outline fading into that of the semicell one-third the distance toward the apex. In front view it has nearly the outline of *E. crassum*. Cytoderm granulate. Diameter about 80-85  $\mu$ . Length nearly  $2\frac{1}{2}$  times as much. Published October 27, '88.

*Xanthidium truncatum*, *spec. nov.* Hastings. (*X. anti-lopeum*, *var. truncatum*. Hast. Oct. 20, '88. *X. Taylorianum*, West, Jour. Roy. Mic. Soc. Jan. '89.) Plate 1, fig. 2a, 2b, 2c, x 500.) Cells longer than wide; cytoderm finely granulate; semicells truncate-pyramidal in front view; four pairs geminate recurved spines to each semicell, those at the superior angles deflexed horizontally and continuous with the truncate or slightly convex ends of cell; short conical central protuberance beaded with about 20 granules in outer circle; side view of semicell nearly circular; end view oval, ends of oval emarginate between the projecting spines. Diameter 55-60  $\mu$ . without spines, with spines 75-80  $\mu$ . Ponds and streams, Rochester, N. H. Oct. 20, '88.

*Staurostrum megalonotum* (Nord.), *var. obtusum*, *var. nov.* Hast. (Plate 1, fig. 3, x 500.) Cells small, about one-fourth longer than broad; cytoderm granulate; isthmus about one-half width of cell; sinus acute angled, amplified outwardly; semicells truncately pyramidal, base convex; sides concave, the truncate ends with six conical processes, only four of which are usually visible in front view, basal angles obtuse (differing in this respect from Arctic varieties); transverse view triangular, the angles rounded, the sides slightly concave. Diameter 45  $\mu$ . Ponds and streams Rochester, N. H. Sept. 8, '88.

*Closterium robustum*, *spec. nov.* Hast. (Plate 1, fig. 4, x 250.) Cells large, semi-lunar, a little more than four times as long as wide; cytoderm smooth; dorsum high convex; ventrum somewhat concave, ventricose; chlorophyl globules large, numerous, scattered; vacuoles large, terminal, distinct, with many moving granules. Empty cells colorless. Diameter 100-120  $\mu$ . Page Brook, Rochester, N. H. Dec. 26, '90.

*Closterium maculatum*, *spec. nov.* Hast. Plate 1, fig. 5. x 500.) Cells very slightly curved, tapering but slightly until near the ends, which are attenuated at the expense of the ventral side, giving them a turned appearance, but without depression on upper side as in *C. turgidum* 16-32 times as long as wide; cytoderm finely areolate and with about six interrupted striæ, to which the areolations give the appearance of dots, three or four together, then a blank space followed by a collection of dots, and so alternately. Diameter 25-30  $\mu$ . Ponds and brooks, Rochester, N. H. Nov. 3, '88.

*Closterium lineatum*, *var. costatum*, *var. nov.* Wolle. (Plate 1, fig. 6, x 250.) Differs from usual form in having the striæ very thick and few in number (only six). Wolle has a figure of a fruiting specimen in P. LXI. f. 3, F. W. Algæ. Nov. 3, '88.



*Closterium angustatum*, var. *clavatum*, var. *nov.* Hast. (Plate 1, fig. 7, x 250.) Cells sub-linear, 12-26 times as long as wide, ends clavate, apices rounded; four prominent costæ; vacuole terminal with dancing granules. Diameter 25-30 m., ends two-thirds as wide. Ponds and streams, Rochester, N. H. Oct. 20, '88.

## EXPLANATION OF THE PLATE.

FIG. 1a. *Euastrum magnificum* variety *crassioides*, var. *nov.* Wolle, x 500.

FIG. 1b. Same, side view, x 500.

FIG. 1c. Same, end view, x 500.

FIG. 2a. *Xanthidium truncatum*, spec. *nov.* Hastings, Front view, x 500.

FIG. 2b. Same, side view, x 500.

FIG. 2c. Same, end view, x 500.

FIG. 3. *Staurastrum megalonotum*, Nord. var. *Obtusum*, var. *nov.* Wolle. Front view, x 500.

FIG. 4. *Closterium robustum*, spec. *nov.* Hastings, x 250.

FIG. 5. *Closterium maculatum*, spec. *nov.* Hastings, x 500.

FIG. 6. *Closterium lineatum*, variety *costatum*, var. *nov.* Wolle, x 250.

FIG. 7. *Closterium angustatum* Kg. variety *clavatum* var. *nov.* Hastings.

### Microscopical Illustrations.

BY HENRY L. TOLMAN,

CHICAGO, ILL.

One of the most difficult features in connection with the illustration of scientific articles is the reproduction of the photo-micrographs or camera-lucida drawings. If the object contains a large amount of detail, a photograph will be the only way by which all the minutiae can be preserved, but no wood-cut can entirely reproduce the original. Of course, it is not always necessary that everything which is seen under the microscope should be seen in the book illustration, and just here is the point where authorities differ on the requisites of a good wood-cut or engraving. Some hold that only the salient parts of an object need be represented; in fact, that the picture is better for having omitted from it all but the few leading features, to which the writer desires to call attention. Others claim that the picture should represent just what the eye sees under the microscope, free from any of the possible or intentional errors of the artist. There is, undoubtedly, much to be said on both sides of the question.

Those who have studied the astonishing cuts called "diagrammatic representations," the counterpart of which they vainly search for in nature, will be strongly in favor of any method which reproduces an object so it can be recognized, and the tendency of the art of the present day seems to be in this direction. Fortunately with this demand comes an improvement in the manner of reproducing photographs and drawings of every kind, which deserves a somewhat extended notice. This is by what is known as the half-tone process, which consists of a photographic copy of the original on a zinc or copper plate and then etching the plate until the drawing appears in relief, and is printed from like an electrotype. In order to convert the smooth,

soft shades of a photograph into a form which will prevent them from printing a solid black, they are broken up into a series of dots more or less close, by the interposition of a finely ruled screen in the camera just in front of the dry plate. On the character of this screen depends in great measure the quality of the finished picture, and the skill of the process worker is best shown by a proper selection of the screen to illustrate the landscape or portrait which is to be reproduced. For bold subjects a coarse screen is appropriate, while for those with great detail and delicate graduations of shades a fine screen is required. These screens are either ruled on paper and copied by the wet-plate process on glass, or directly on glass, the lines varying in distance from 1-100th to 1-150th of an inch. Obviously for nearly all microscopical photographs the fine screens must be used, but it will be found that some of the contrast must be sacrificed thereby.

Of course, there are some subjects which cannot be reproduced by the half-tone process. Where the object is entirely novel and the peculiar grain-like structure of the picture might cause erroneous conclusions, where there is a large amount of fine detail, or where, as in diatoms, the structure consists of a series of fine lines, or minute dots, elevations or apertures, then this process is not so applicable. But even here it is serviceable if only the general appearance of the object is desired. One suggestion may be allowed to be offered—that in studying all process work the best effect is given if the picture is held at a rather greater distance from the eyes than the distance of normal vision, *i. e.*, ten inches. By this means the attention of the observer will not be distracted by seeing the individual dots or points of which the image is made up, but he will still be enabled to appreciate all the delicate effects of light and shade.

There are several methods in common use for producing what are called half-tone prints. The bitumen process, though commercially but little used on account of its slowness, is one of the best for reproducing detail, especially since Valenta has discovered some valuable improvements, while the numerous so-called enamel processes which have recently been introduced, modifications of the gelatine process, are valuable in that they are rapid and cheap. The cheapness, of course, is one of the strongest recommendations for the use of any half-tone process, as a cut which on wood might cost from \$10 to \$20 could be put into a half-tone for \$3 to \$5. Another advantage is that the amount of detail in a picture would make no difference in the price of a zinc plate, it being sold for a certain price per square inch, while the cost of a wood-cut would depend very largely on the fineness of the detail which was to be reproduced. This kind of illustration has already been largely used in medical work, and the A. M. M. J. a year or two ago republished some half-tone cuts by the author of photo-micrographs of sections of woods, showing

the capabilities of the process. For the representation of very delicate work, the numerous photo-gelatine processes are more satisfactory, as the minutest detail can be accurately shown, but they are much more expensive, and must be printed on special paper and presses. But graphic illustrations in some form add largely to the attractiveness of an article, as well as enabling the reader to comprehend at a glance the idea which is sought to be conveyed. Few can draw, but dry plates have made photo-micrography almost a pastime, and the half-tone process offers, by all odds, the best mode of reproducing photographs with all the accuracy of the original, and with a minimum of expenditure of time and money, and it is to be hoped scientific periodicals will be led to make more use of this new method.

---

### Impressions of the Antwerp Microscopical Exposition.

By R. H. WARD, M. D.

President's Remarks at the Microscopical Section of the Troy, N. Y., Scientific Association, Oct. 19, 1891.

[Continued from page 140.]

#### ILLUMINATING APPARATUS.

Though made a separate class in the official announcement of the exposition, most of the illuminating expedients were necessarily merged in the exhibits already mentioned. The recent remarkable development of the substage condenser, as an inevitable result of the adoption of the apochromatic objective, was seen everywhere. Powell & Lealand submitted their dry apochromatic condenser of n. a. 0.95, able to work through common slides and especially adapted to photomicrography, and their apochromatic homogeneous immersion condenser, of n. a. 1.40, for special researches. The Abbe condenser, now made also in an achromatic form by its original producers, the Zeiss house, is universally adopted by the continental makers.

The only special exhibits in illumination worth mentioning were in the use of electricity. Dr. H. Van Heurck, for ten years an enthusiastic advocate of this method, exhibited the various devices he has employed. He believes that the incandescent light, while possessing the mildness of the petroleum lamp, excels it and nearly equals monochromatic sunlight in the power of showing with clearness fine details like the markings of *Amphipleura* or the 19th band of Nobert's plate. This is believed to be due to its greater intensity, enabling sufficient light to be obtained from a very small pencil of rays, and to the greater proportion of the shorter waves of the blue and violet end of the spectrum, which gives its peculiar whiteness to this light. In view of these advantages it is to be regretted that this light, though perfectly attainable with the now available apparatus, has not yet been able to compete successfully, for general use, with the more convenient petroleum lamps.

A remarkable collection of batteries, dynamos, and lights suitable for microscopical use was exhibited by the great French electrician, G. Trouvé, of Paris. His "photophore," consisting of a little drum containing a bull's-eye lens with a tiny electric loop behind it, the whole sliding easily up or down a vertical pillar and capable of turning at any angle, like the search-light of a ship, seems by far the best electrical illuminator yet produced. It apparently needs only to be freed from its dependence on the necessarily troublesome battery by the presence of an electric service-wire in every house to become *the* illuminator of the microscope. By this exhibit, M. Trouvé, whose biography, lately published in a fascinating book as "The History of an Inventor," seems more like a romance than a history, added another diploma of honor to a former list of awards of which any inventor in any line of research might well be proud.

#### PHOTOMICROGRAPHY.

This class was, of course, exceptionally prominent. The apparatus pertaining to it was mostly included in the makers' exhibits of microscopes and accessories.

A. Nacet, of Paris, whose personal experience in photomicrography insures a special interest in the work and an exceptional familiarity with its demands, was first in the variety of his appliances and unsurpassed in their quality and completeness. His "grand apparatus" has a horizontal bellows capable of easy adjustment for distances up to about two meters. The stand is placed horizontally in connection with this; but it has also an extra body branching vertically from the main body, just behind the objective, and supplied with a sliding prism which serves, when racked down, to totally reflect the light from the objective up through the vertical tube which is used for observation while adjusting the object and the illumination, and when racked up permits the same pencils to pass horizontally directly to the sensitive plate at the far end of the bellows. His "petite apparatus" designed for elementary work is very simple, the dark chamber being a plain box supported over the ocular end of an ordinary microscope standing either vertically or inclined. This box, with its sensitive plate at the top, can be clamped at various heights upon a pair of parallel supporting bars, the latter being jointed at the level of the microscope stage, so that they may be maintained parallel with the body at any desired inclination. His mammoth style of "inverted microscope" (which will be remembered as a conspicuous feature of his exhibit at our Centennial exhibition at Philadelphia in 1876) is also fitted with an inverted dark chamber which is supported upon the top of the inclined tube, and which, with such a support, has naturally the advantage of extreme steadiness. But Nacet's most unique device is the apparatus for instantaneous photography of living objects, as infusoria, etc. This is an elaborate and finely-built affair. The inverted dark cham

ber is supported upon pillars, several feet above the body of a vertically-placed stand with which it is connected by means of a bellows-tube in the form of an inverted pyramid. An ingenious reflecting arrangement enables the observer to examine most conveniently the image on the focusing plate above his head. An extra body branches obliquely (after the Nacet fashion) from the side of the ordinary one, and, by aid of a sliding reflecting prism, is used for adjusting and examining the object until the instant when a picture is required, at which time a sudden movement of the prism allows a momentary flash of the microscopical image upon the sensitive plate. The writer did not see this very ingenious apparatus in operation; but it is said by competent authority to work perfectly with electric light or direct sunlight.

Superb photographic outfits were likewise displayed by E. Hartnack of Pottsdam, the Carl Zeiss house of Jena, Carl Reichert of Vienna. Ernest Leitz and W. & H. Seibert, both of Wetzlar; and scarcely inferior ones by other makers. Most of the makers show two styles corresponding more or less to the first two Hartnack styles above mentioned; one horizontal and elaborate, for long distances, and a simpler form inverted and vertical or inclined, for short distances of less than about a meter.

Special photomicrographic stands, with bodies wide and short, are shown by Zeiss, Reichert, Watson (the Van Heurck stand), and others. Several manufacturers also present special objectives, or illuminators with heliostats, lime-lights or electric lanterns, well adapted to this work.

Photomicrographs in great number and variety and of every degree of excellence were displayed upon the walls and crowded in the cases not only of the main hall but also in a separate room devoted to them.

Thirteen prizes, of several different grades, were awarded in this department. The first of these would certainly have been voted to Dr. Van Heurck for his photographs of diatoms, on account of the clearness and general excellence attained in treating subjects chosen for their extreme difficulty; but, though not a member of the jury of awards, his prominent connection with the enterprise as the originator of the exposition and the leader of its management led him, with very good taste, to decline to be considered a competitor for any prize.

One grand prize was awarded, to Dr. Giorgio Roster of Florence, who exhibited four dozen extremely fine photographs of natural-history objects, including diatoms, and of pathological subjects. These were models of good photography and mounting and of scholarly labelling and arrangement.

Four diplomas of honor followed: one to Prof. J. D. Cox of Cincinnati and Mr. C. Houghton Gill of England, who conjointly with Dr. Van Heurck exhibited a number of diatom photographs, magnified from 500 to 1,500 times, displaying the structure of the shells in a decisive manner by means of edge views of broken

fragments of valves with their areolæ filled in with silver sulphide, mercurous sulphide, or platinum; one to Mr. Andrew Pringle, and one to Mr. Thomas Comber, both of England, for fine diatom photographs; and one to F. Thévoz & Co., of Geneva, for a large and excellent variety of "phototypes," impressions suitable for book illustrations, from photomicrographs of diatoms, infusoria, microbes, and natural-history objects generally.

A novel and remarkable series of photomicrographic transparencies suitable for the magic lantern was shown by Antoine Lumière & Son, of Lyons, France. The gelatin bromide of silver transparencies were cleared and stained, by some process claimed as original, so that the color of the object as seen in the field of the microscope was exactly reproduced. Thus desmids, for instance, were stained a natural green, while microbes, animal tissues, or plant sections, which are usually stained for the microscope, were colored to correspond. The transparencies when held up to the light, or displayed by hanging in the windows, represented vividly the field of view in the microscope itself, and in the magic lantern or with a sufficiently low power of the projection microscope they produced that effect well upon the wall. At a lecture in the amphitheatre many of these views, including a series representing the embryology of the chick, were projected upon the screen with good effect.

Several collections that were not remarkable as photographs were interesting, and perhaps even more valuable as demonstrations of natural history or of economic science, and as examples of thorough and useful scientific work. Such was the comparative study of the structure of oily seeds by Director Fréd. D'Hont and Mr. F. Moreau, of the communal laboratory at Courtrai, Belgium, illustrated with six large frames full of photographs ( $\times 100$ ), and with a side case displaying a set, complete in every detail, of the few simple instruments, reagents, etc., used in the investigation. A somewhat similar study of the comparative histology of the seeds of the cabbage, mustard, flax, and other plants of commercial importance was shown by Director Paul Claes and Mr. Émile Thyès of the state agricultural laboratory at Louvain. Mr. Ed. Anseel, of Antwerp, likewise exhibited a set of three dozen views, adequately magnified, demonstrating the character of the hairs of different animals. It would be difficult to commend too highly the educational and economical value of this class of work.

#### BACTERIOLOGY.

The two principal exhibits in this class consisted of extensive selections from the vast variety of apparatus made by E. Adnet and by V. Wiesnegg, both of Paris. The sterilizing and incubating ovens, baths, furnaces, and lamps, stills, filters and refrigerators, and the large variety of associated apparatus constituted ex-

hibits of exquisite work in brass and copper and glass that were among the most showy as well as instructive in the exposition. To attempt a description would be to discuss the late progress in the whole prolific specialty of bacteriology, and would fill a book.

But the most remarkable exhibit in this class, and the only one which very worthily took a grand prize, was that by the city of Paris, which presented, crowded upon a line of two-story tables in the middle of the hall, a demonstration of the famous work in the biological analysis of air at the municipal observatory at Montsouris. Not only was the great variety of ingenious apparatus displayed, but the methods of combining and using it, and the results attained, were shown as fully as possible. The publications of the observatory, and of the director, Dr. Miquel, were also presented, and secured a well-earned gold medal for Dr. Miquel.

#### PREPARING APPARATUS.

The principal microscope makers exhibited, of course, the usual variety of dissecting, or, according to the better continental phraseology, preparing microscopes. The most important general exhibit that seemed to belong mainly in this class was by Rud. Siebert, of Vienna, who displayed a variety of fine laboratory apparatus, among which the delicate glassware was notable. He also exhibited bacteriological apparatus, mostly of the smaller sorts, in great perfection and variety.

Microtomes and their accessories formed two special exhibits of nearly equal size and interest, by R. Jung, of Heidelberg, and C. Erbe, of Tübingen. Both of these exhibits covered a wide range, from the magnificent and costly machines capable of cutting very large sections with the greatest delicacy, to the smaller and simpler affairs that were carefully contrived and well made and efficient for the general use of students. Both of these makers received diplomas of honor, the medium models of Erbe being especially complimented for their combination of fine workmanship and moderate price.

Of the microtomes offered by the general manufacturers, those by A. Nachet, of Paris, and Chas. Reichert, of Vienna, were most remarkable.

#### MICROSCOPICAL PREPARATIONS.

Perhaps the most famous professional preparer of objects is J. D. Moeller, of Wedel, Holstein, whose type slides of 400 diatoms have long been familiar. In addition to a varied selection of excellent diatoms and other mounts, he exhibited his greatest and incomparable production containing at once 4,030 diatoms systematically arranged and accompanied by an atlas of 59 folio plates illustrating the different portions of the preparation.

Scarcely, if at all, inferior in scientific or commercial importance, were the large and varied exhibits of excellent slides by Edward Thum, of Leipzig, and J. Tempère, of Paris. The last

named preparer, a series of whose instructive preparations was selected for projection upon the screen to illustrate lectures in the amphitheatre, showed comparative slides having six different kinds of blood, or of wood sections, etc., ingeniously and conveniently grouped and labelled on one slide.

Dr. Joseph Montaldo, of Turin, exhibited a large and fine collection of slides illustrating wood-structure; and Drs. M. and Ad. Jolles, of Vienna, contributed a similarly valuable study of food-substances.

Even more notable, though out of competition for the prizes, was the collection of 10,000 preparations by a member of the jury, Prof. H. Bolsius, S. J., of the theological college at Louvain. These slides represented in serial sections (with also a resultant monograph) a study in the anatomy of the leaches, the whole being, to say the least, one of the best examples of individual work in the exposition, and offering to every visitor an instructive and inspiring model of good work in laboratory biology.

Mr. Julien Deby, of England, received a gold medal in recognition of several series of preparations showing thoughtful and able study of interesting subjects mostly connected with insect and plant life.

A notable feature of the exhibition was the free use of the 3x1 in. slides by continental preparers, in preference to the various so-called continental sizes. If confined to professional preparers this might be considered a concession to the requirements of English and American buyers; but being noticed also in the work of those who prepare for their own use, it goes far toward indicating that, in spite of its well-known minor disadvantages, the 3x1 standard was not a very undesirable selection.

#### LITERATURE.

The invitation for an exhibition of microscopical books secured only a few responses. The owners of valuable volumes are loth to be separated from them for months; and the possessors of priceless rarities of this kind would seldom care to trust them in a public exhibition where to be of any real use they must be handled freely by the visitors. Of modern publications, only the two French journals and a limited number of books and pamphlets on the microscope, diatoms, botany, etc., appeared.

One of the smallest and most unpretending of the works was certainly one of the most remarkable; a little book on "*Sept Objects Regardés au Microscope*," by Dr. E. Giltay, professor of botany in the National School of Agriculture at Wageningen, Holland. The seven objects are: 1, colored lines on opposite sides of an object slide; 2, a cylinder of smoked glass; 3, starch; 4, air bubbles; 5, milk; 6, collenchyma; 7, an Abbe diffraction plate. In describing very plainly and briefly the study of these simple objects a great amount of valuable information is introduced concerning microscopical manipulation, observation, and



interpretation. Small as this book seems, it is actually only half as big as it looks, every second page being a duplicate, repeating in French the substance of the opposite page in Dutch. In this very practical way the little book appeals to a greatly enlarged circle of readers.

Among the larger exhibits were several works by Dr. Wm. Behrens; and seven volumes by Dr. J. Pelletan, of Paris, in addition to the fifteen volumes of his "*Journal de Micrographie*," the whole representing an extraordinary amount of able work.

Dr. Henri Van Heurck exhibited the four editions of his treatise on the microscope, the two grand volumes of his "*Synopsis des Diatomées de Belgique*," with its atlas of 3,100 figures, and seventeen pamphlets. These, in connection with his large collection of interesting antique microscopes, his apparatus for electric lighting, for photomicrography, for micrometric ruling, etc., his unsurpassed photomicrograms of diatoms and other test objects, and his preparations of type specimens of the diatoms of Belgium, on which his "synopsis" was founded, rendered him by far the most important exhibitor at the exposition. The fourth edition of his book on the microscope was brought out on this occasion, and it was so freely rewritten from the former editions as to be essentially a new book. The modern optics and present construction of the microscope are adequately discussed, the latter, naturally, most fully from continental experience. The general management of the microscope and preparation of objects is included, photomicrography and the staining and slicing of tissues having prominence according to the fashion of the time; but the application of the microscope to the study of plants, and especially of diatoms, is omitted, to appear as a special volume hereafter. Desiring to make the present volume worthy and able to serve as a "*livre de luxe*" commemorative of the occasion without the natural impediment of a proportionally high cost, the accomplished author secured its publication in a grand volume at his own expense, and had it sold at a price that could scarcely be believed to cover the cost of printing. Even to those fortunate enough to have received the beautiful "diploma of honor," this souvenir volume by Dr. Van Heurck will be second to nothing as a keepsake of the Antwerp Exposition.

---

### EDITORIAL.

---

**Priority in Giving Scientific Names.**—Much stress has been put upon this topic because serious confusion has been caused in many branches of science by two or more scientists putting different names upon the same form. In order that confusion may be avoided it has been generally held that when one proposes a new name, he shall give it and the description reasonable pub-

licity, so that with reasonable search on the part of other scientists duplication of descriptions may be avoided. What constitutes such reasonable publicity has not been strictly and minutely agreed upon. But we may say, for instance, that publication in the *Journal of the Royal Microscopical Society* is reasonable notice to the scientific world. And we may say also as an example that publication in the obscurest county newspaper in our newest settled territory is not reasonable warning to others of priority claimed.

One of our correspondents says that he has published in a local paper of New Hampshire some descriptions of desmids claimed by him to be entitled to new names, and his claim to priority dates from such publication. We are of opinion that such a claim will not be pronounced valid by naturalists in general. Not one in a thousand of the naturalists of the world has seen or could be expected to see the paper in question unless the author took the trouble to mail a large number of copies to all parts of the world.

Whether publication in this JOURNAL would be recognized as of sufficient publicity will perhaps be questioned by some, but it is enormously superior for this purpose to a county newspaper. We shall not feel inclined to defend our correspondent's claim as stated by him, unless it secures quite general acquiescence, and we feel sure that it cannot.

Let us suppose that Smith publishes in the *Fifield (Wis.) Advocate*, July 17, 1891, the name and description of a new desmid; and that Jones publishes in the *News-Sun*, of Seymour, Texas, July 26, 1891, a different name, but with such description that all can see that it is the same desmid. Neither of the above papers has 400 subscribers, as we are informed. Should Jones also get his description into the *J. R. M. S.* in September, and Smith fail to do so, Smith's supposed priority would never be recognized. We do not believe that either the publication of July 17 or that of July 26 ought to be considered valid.

**The Science Meetings.**—The American Microscopical Society will sit at Rochester, N. Y., August 9 to 12, and the A. A. S. will sit in the same city August 16 to 23. This leaves Saturday, Sunday, and Monday for waste time between the two meetings. The American Geological Society and two other associations will sit on the 15th and 16th, a much wiser plan than that adopted by the microscopists. Why will the latter go on planning so badly? In Washington, last year, an attendance of 150 members of the Microscopical Society was confidently predicted and expected by the managers. Only 34 members registered, and a third of those belonged here. Why string out 15 or 20 papers over four days and read them before less than a score of listeners? Several sections of the A. A. S. draw audiences of treble that size.

Gentlemen, arrange your next meeting to be held on Monday

evening, Tuesday, and Wednesday morning of a week occupied by the A. A. A. S., and see if you do not succeed better. You have already begun to do wisely in accepting the city selected by the A. A. A. S. for your place of meeting. We are not oblivious to the disadvantages of such a course, but the fact is that you are not strong enough yet to cut loose and to try to stand alone.

### MICROSCOPICAL APPARATUS.

**The Lane-Sear Microscope Lamp.—Stability.**—No lamp that is easily upset is a desirable companion to the microscopist. In the "Lane-Sear" lamp stability is insured by having the oil vessel arranged around a central stem which rises from a thin but heavy base and which is instantaneously secured at any required height by the long radial screw shown in the illustration. This mode of setting the burner at any required height is very good.

**Power.**—This is obtained in its maximum degree by the employment of the Argand burner and by having a large condenser on a double-jointed arm mounted with a ball-and-socket joint.

**Position.**—It is often desirable, especially when working with the higher powers, to get the flame as close as possible to the reflector. Every practical microscopist sometimes tries to do this. It is here accomplished by getting the burner on the very edge of the oil-tank and within a very few inches of the table. No other lamp of equal power will permit of this, and with any ordinary table lamp such a position is wholly out of the question.

**Safety.**—Safety in replenishing is secured by having the cistern tubulated at the *opposite* edge from the burner.

**Convenience.**—By removal of the bee-hive porcelain shade, which rests on a gallery surrounding the chimney, and which is commended though not essential in using the lamp for microscopical observation, and by adjustment of the reading shade the lamp becomes at once an ordinary table reading-lamp of great power and efficiency.

**Accessories.**—(a) On a ringed arm, adjusted by a set-screw, and which can be swung around the central stem so as to graduate and sometimes localize the heat, a porcelain water-bath may be used. A smaller basin is sunk therein, and it has a light cover of the same ma-

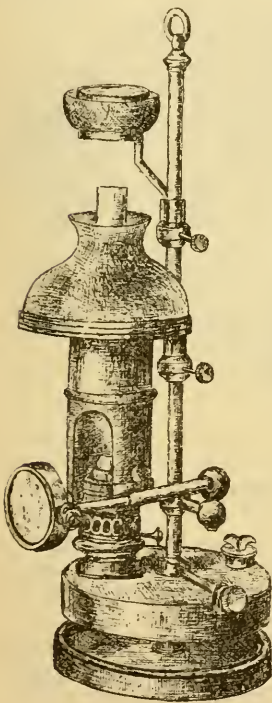

terial. This is most useful for drying preparations or sections previous to mounting them. It admits of every possible graduation of heat up to  $212^{\circ}$  Fahr., and is preferable to the ordinary modes of drying specimens.

(b) By lifting off the porcelain water-bath we bring the water oven into play. This attaches itself by a bayonet clip (not seen in the figure) to the brass carrier, and cannot fall off. It is the most useful accessory known. It is a water-oven of about 3 fluid oz. capacity with perforated tubulure for the admission of water and escape of steam, and a draw-off tap at the side (mounters only know how often a single drop or two of very hot water comes handy). On the top is a tray where cements, mediums, solvents, slides, etc., can be kept cold, warm, or hot, at the operator's discretion, and inclosed by a door on each side (one only can be shown in the illustration, Fig. 3, page 166), is the water-jacketed oven, size  $3\frac{1}{8}$  by  $2\frac{1}{8}$ , having a lift-out rack fitted to carry a dozen 3 by 1 slides without the possibility of their coming into mutual contact, and which can be drying or hardening without the constant and wearying attention of the operator, and at any desired temperature under  $212^{\circ}$ .—*English Mechanic*.

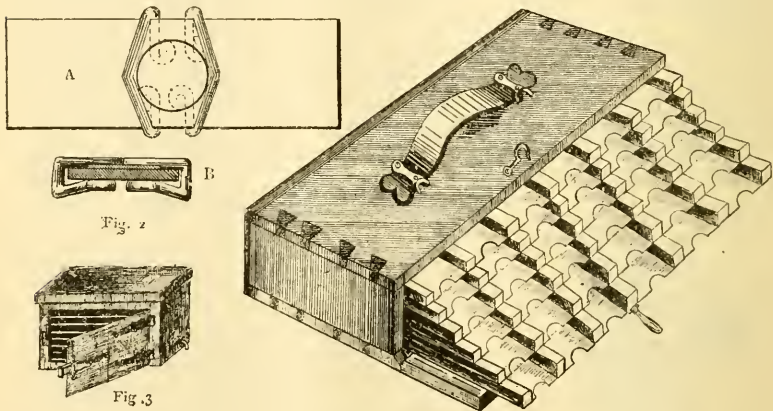

**A Box for Slides.**—Mr. E. Mosely has sent to the *Science-Gossip* the description of a cleverly constructed box for slides. The advantage will be apparent from figure 1. By pulling out the bottom drawer, the others come out just far enough to show the labels on the slides; thus it will be at once noticed if any one slide is missing. It well deserves the name bestowed on it by its inventor, namely, "Compacta," for it is exceedingly compact, and it is so simple that it cannot easily get out of order.

**A Pressureless Mounting-Clip.**—A new form of mounting-clip, designed to hold the cover-glass without pressure, is a great improvement upon the spring-clip commonly used. Fig.

2 A is an illustration of the clip in use as seen from above, and Fig. 2 B is an end view of the same as seen from a section through the cover-glass. The clip should be made of rather stout springy wire, so as to grasp the slide firmly. This clip will be less liable to shift or become detached from the slide; and it has the advantage of being suitable for rectangular as well as circular cover-glasses.—*S. Pace, in Hardwick's Science-Gossip.*

**A Cheap Camera.**—Cut a hole in one end of a cigar box and insert a piece of metal in which is a very fine hole. Blacken the whole inside of the box with dead black varnish, and close every crack so that not a ray of light shall enter except through the small hole. At the other end a groove may be made into which to insert the sensitive plate and the lid must be light-tight. A lens is not necessary, but the hole must be such as is made by a pin point, must be perfectly round and without irregular edges. A watchmaker can drill such a hole very easily. Tell him to make it 1-50th inch.—*Work.*

**To Arrange a Photomicrographic Dark Room.**—A simple dark closet, large enough to contain a table and a shelf or two, may be used. The necessary materials are a ruby lantern; three flat trays, or even plates, if large enough to contain the photo plates, a glass graduate, a small scales, and several bottles for solutions. The water supply may be taken from a pail with a rubber tube in the side, furnished with a spring clothes-pin or clip; the waste water may fall in a pail below; a negative rack and a 2-inch camel-hair brush are conveniences. The chemicals will depend upon the formula recommended by the maker of the dry plate used, but the following specimen list will do the work: Soda sulphite, eikonogen or hydroquinone, potassium carbonate, and potassium bromide, for developing; mercury bichloride for intensifying; red prussiate of potash for reducing; soda hyposulphite for fixing. A printing outfit for paper prints would include one or two printing frames. Sensitized paper, gold chloride, soda acetate, card mounts, and two flat trays for toning and fixing. Washing prints means prolonged soaking in any convenient vessel. Vols. VI and VII of the A. M. MICROSCOPICAL JOURNAL contain a series of excellent papers on photomicrography, by R. Hitchcock.

## MICROSCOPICAL MANIPULATION.

**Collecting Terrace Dust.**—Mr. W. J. Simmons, of Calcutta, sends us a small packet of dust from the roof of a house in Calcutta, and adds a note descriptive of its collection.

“Our houses in Calcutta are all flat-roofed. A parapet surrounds the terrace, the latter being often an extensive surface, which receives a great deal of dust of all sorts; such dust is drifted by the wind into the leeward corners of the

terrace, where it collects in little black heaps, not unlike gun-powder. It also gathers about the spouts which carry off the rain-water. An old friend of mine, Mr. Charles Blechynden, who has resided in India for many years and who still takes a keen and fresh delight in natural science, told me recently that he found that by plunging a powerful horseshoe magnet into a handful of our black 'terrace dust' minute particles were attracted to the magnet poles, which he surmised might prove to be meteoric dust. I have improved on Mr. Blechynden's process; with a camel's hair brush I brush off the dust from the poles onto a sheet of thin white paper, and then by drawing the magnet backward and forward *under* the paper I draw away the iron particles, which are thus practically twice magnetically sifted. On mounting these twice-sifted particles in balsam and placing them under a microscope, I find the material includes a few spherical bodies; some are opaque and of a black or rusty red color, while others are transparent spheres, which enclose bubbles as well as patches of dark granular matter. The dark spheres remind one, when examined with a half-inch, of small shot; and their spherical form suggests that, like small shot, they were once in a state of fusion and have dropped from a considerable height, a view which is supported by the glassy spheres enclosing minute bubbles. If this magnet-attracted dust, which is obviously iron, is neither meteoric nor volcanic in its origin, what is it?

"To the best of my recollection I have never seen nor heard of the magnet being used as a means for collecting meteoric dust, though it is so obvious that it seems likely to have suggested itself to others. It certainly furnishes us with a simple and reliable method of separating from the dust collected on house tops the iron particles in it; and if the particles so obtained are meteoric or volcanic, then Mr. Blechynden's device will enable observers all the world over to collect this material, and to institute comparative observations with the view of determining at what seasons of the year, and in what localities, most of this spherical iron dust falls. I have already obtained it from three places—my friend's house at Alipore, the roof of my own residence, and the roof and tower of the High Court here. My house is a mile and a half from the High Court, while Alipore is three miles from reach of the above localities; indeed a triangle described so as to include each of the three points named would roughly be an isosceles triangle, with the line joining my house and the High Court for its base. The terrace of the Court-house is probably quite a 100 feet, and the roof of its tower about 160 feet above the ground. The dust sent is from the roof of my house. The magnetic method of getting at these meteoric or volcanic particles may be well known; if so, no harm can be done in calling attention to it in this brief note. If the method be new, my friend Mr. Blechynden has done a service to science."

### BIOLOGICAL NOTES.

**Circular Growth of Fungus.**—Referring to the note on page 101 of the *JOURNAL*, bearing this same title, Dr. Shanks, of Albany, write: "Myxomycetes mean mucous-like fungi. They are characterized by a mucilaginous or protoplasmic filamentous matrix. A creeping amœboid mass develops from the spore and grows by absorption of nutriment and also by union or fusion of contiguous masses. Certain necessary conditions of the atmosphere and soil being present, the growth of the fungus is very rapid, two or three days being sufficient to bring about fructification. In the above case there was probably an original central colony which grew by extension, like an immense 'ring-worm,' and only became visible when the spores were developed."

### DIATOMS.

**The Mobile Deposits.**—Mr. K. M. Cunningham sends us the following list of the species of diatoms occurring in the deposit of marsh mud on the west margin of Mobile river. It is located three-quarters of a mile north of One-Mile creek, within a hundred and fifty feet east of the main line of Louisville and Nashville R. R., near Mobile, Ala. The deposit was discovered in July, 1891, the stratum having a depth of about six feet, and has been fully described in the February, 1892, number of this journal. The species included in this list were identified through the courtesy of D. B. Ward, M. D., Poughkeepsie, N. Y.

Achnanthes Sp ? (fine form).	Epithemia turgida, Kütz.
{ Actinocyclus Barklyi, Ehr.	"    zebra, Kütz.
{ = A. dubius. Grun.	Eunotia major, Raben.
Amphiprora pulchra, Bail.	"    diodon, Ehr.
Amphora proteus, Greg.	"    pectinalis, Kütz.
Actinoptychus undulatus, Ehr.	"    triodon, Ehr.
Biddulphia lævis, Ehr.	"    dodecaodon, Ehr.
Campylodiscus echeneis, Ehr.	Grammatophora marina.
= C. cribrus, W. Sm.	Gomphonema capitatum (variety).
Cocconema lanceolatum, Ehr.	Melosira granulata, Bail.
Coscinodiscus asteromphalus, Ehr.	"    sulcata Kütz = Orthosira marina, W. Sm.
Coscinodiscus robustus Grev. (small variety).	Navicula amphirynchus, Ehr.
Coscinodiscus subtilis, Ehr.	"    cuspidata, Kütz.
Cyclotella striata, Grun.	"    Dariana, A. Schmidt.
Cymatopleura elliptica, Breb.	"    didyma, Ehr.
Cymbella gastroides, Kütz.	"    Fischeri, A. S.
Epithemia gibba, Kütz.	"    formosa, Greg.

Navicula lyra, Ehr.	Pleurosigma Balticum, W. Sm.
“ maculata, Edw'd's	“ attenuatum, W. Sm.
“ peregrina, Ehr.	Stauroneis acuta, W. Sm.
“ Smithii, Breb.	“ gracilis, Ehr.
“ viridis, Kütz.	Surirella cardinalis, Kitton.
“ (sp) Schmidt's atlas,	“ elegans, Ehr.
Pl. 45, fig. 13.	“ Saxonica, Auersw.
“ nobilis.	“ Striatula, Turpin.
“ trinodis.	Terpsinoë, musica, Ehr.
Nitzschia circumscuta, Grun.	“ intermedia, Pant.
“ scalaris, W. Sm.	“ “ (sporangial).
“ sigma.	Triceratium favus, Ehr.
“ dubia.	Tryblionella punctata, W. Sm.

A more extended examination of the deposit is liable to extend the specific forms to about sixty species.

The matron of the Mobile Protestant Orphan Asylum, Mobile, Ala., has about 50 vials of washed diatoms for distribution. The washing, which is very laborious, was done by the boys under direction of Dr. Taylor. We understand that any person desiring a vial can address the matron, sending such contribution to the funds of the asylum as he deems the material to be worth to him. We suggest that a dollar is not too much to enclose.

## BACTERIOLOGY.

**The Examination of Sputum for Tubercle-Bacilli.**—In a recent number\* of the *Medical News* Dr. V. A. Moore has called attention to the importance of making an examination of the sputum for tubercle bacilli in the early stages of all lung disturbances in which tuberculosis may be suspected. The good results that are being obtained in the treatment of tuberculosis when the cases are taken in hand before any serious pathological changes have taken place emphasizes the necessity of early sputum examinations as a means of diagnosis. In order to obviate the difficulties usually met in discovering the tubercle-bacilli in cover-glass preparations made directly from the crude sputum of patients in the first stages of the disease a few methods that seem not to be in general use are given. These, together with a method of staining the tubercle-bacilli, are as follows:

**Biedert's Method.**—The object of this method is to find the tubercle-bacilli when they are present in the sputum in small numbers. In 1886, Biedert (1) called attention to the fact that smearing the crude sputum on the cover-glass and staining the same does not give accurate results, so far as detecting the number

\* May 14, 1892.

1. Biedert, Ph.: Berl. klin. Wochenschrift, 1886, No. 42, p. 43.



of bacilli is concerned. This is due to the fact that clumps of sputum that usually contain a larger number of tubercle-bacilli than the more liquid portion are so deeply stained as to obliterate their presence. In order to reduce the sputum to a more homogeneous consistence and at the same time to concentrate into a small mass the bacilli in a large quantity of sputum, Biedert mixed the sputum with twice its volume of a 2 per cent. solution of caustic potash or soda (soda being preferred) and boiled the mixture until perfectly fluid, after which it was placed in a conical glass and allowed to stand until a sediment had formed. Upon decanting the supernatant liquid, tubercle-bacilli otherwise difficult or impossible to find were readily discovered in stained cover-glass preparations made from the sediment in the bottom of the vessel. In a recent article, <sup>(2)</sup> Biedert again dwells on the value of this method. Although the process requires considerable time, the advantage to be gained by concentrating the tubercle-bacilli in a large quantity of sputum into a small sediment is obvious. This is also a convenient method for preserving sputum for subsequent examinations, as the bacteria remain unchanged for a considerable time.

Among the various processes that have been proposed and which are based upon the principles set forth by Biedert, the following may be mentioned :

Kaatzner <sup>(3)</sup> employed from a 1 to 3 per cent. solution of caustic soda or potash, which dissolved the cells, mucus, etc., but preserved the elastic fibers and bacteria. Cover-glass preparations were made from the sediment. He also employed a dilute solution of acetic acid to clear the preparations.

Kühne <sup>(4)</sup> added an equal volume of a saturated aqueous solution of borax to the sputum in order to overcome its viscosity and to obtain a thin even layer on the cover-glass. This mixture remained good for several weeks. Putrefaction is prevented and the tubercle-bacilli continue to stain nicely. He also used for less viscid sputum a concentrated aqueous solution of ammonium carbonate. Kühne also dwells upon the importance of estimating the number of tubercle-bacilli present.

Mühlhäuser <sup>(5)</sup> does not advise the use of stronger solutions of caustic potash than 2 per cent. He differs from Biedert in taking a smaller quantity of the sputum and adding from six to eight times its volume of the potash solution.

**Gabbet's Staining Process.** <sup>(6)</sup>—This method was found to be very convenient and quite satisfactory in staining the tubercle-bacilli both in cover-glass preparations and in sections of tuberculous tissue. The stain is practically the same as that used in Ziehl-Neelsen's method, but the acid is combined with the

2. *Ibid.*, 1891, No. 2, p. 31.

Kaatzner, P.: Wood's Monographs, V, 1890, p. 97.

Kühne, H.: Centralblatt f. Bakteriologie u. Parasitenkunde, viii, 1890, p. 293.

5. Mühlhäuser, H.: Deutsche med. Wochenschrift, 1891, No. 7, p. 282.

6. Kahlden, C. v.: Technik der histologischen Untersuchung, etc., Jena, 1890, p. 59.

methylene-blue solution, thus decolorizing and counter-staining at the same time. This method was compared very carefully by the author with those usually recommended and found to give equally as good results as the more lengthy processes. The formulæ for the solutions and the technique in their application are as follows:

## (1) The stain—

Fuchsin, . . . . .	1 gram.
Absolute alcohol, . . . . .	10 cubic centimeters.
5 per cent. carbolic acid, . . . . .	100 cubic centimeters.

## (2) The decolorizer and counter-stain—

Methylene-blue, . . . . .	2 grams.
25 per cent. sulphuric acid, . . . . .	100 cubic centimeters.

**For Cover-Glass Preparations.**—After the smeared cover-glasses have dried in the air, they are passed film upward three times through a flame, after which the film is covered with the stain, which is allowed to act for about two minutes. The preparation is then rinsed in water and stained for one minute with the second solution, when it is again rinsed in water. It can be examined at once or allowed to dry, when it can be permanently mounted in balsam. For sections, it is necessary to allow the reagents to act for a longer time. Better results may be obtained by heating the staining fluid until steam is given off. This is easily done by passing the preparation covered with the staining fluid several times through a flame, or heating the solution in a watch-glass upon which the cover floats film downward, or in which the sections are immersed.

The tubercle-bacilli will appear upon a microscopic examination (an oil immersion lens is desirable) as slender, more or less curved, rod-shaped bodies of a deep-red color, while the surrounding tissue and other bacteria present are stained a more or less intense blue. There are occasionally small oval or round bodies found in preparations of sputum that retain the fuchsin stain and which beginners have frequently mistaken for tubercle-bacilli.

The solutions used in this method may be kept in stock for a long time (two to three years), but better results are obtained when moderately fresh solutions are employed; a 10 per cent. solution of sulphuric acid was found to be quite as good and considered preferable to the stronger one recommended in the method.

---

### OBITUARY NOTICES.

---

**Dr. L. D. McIntosh.**—Dr. McIntosh having graduated from Caledonia, Vt., Medical College in 1863, entered the army shortly thereafter as a surgeon. He then, after this service, returned to Sheboygan, Wis., where he practiced medicine until about fifteen

years since, when he came to Chicago, and identified himself with the McIntosh Galvanic Faradic Company in the manufacture of scientific appliances.

His practical and ingenious mind was soon interested in mechanical improvements of such instruments as came under his observation, which observation soon extended to a large number and variety of scientific appliances. Among these improvements may be mentioned galvanic batteries, dental instruments, optical lanterns, projection microscopes, and microscopical stands.

Dr. McIntosh was known in all scientific circles, and was a member of many scientific societies. Among these may be mentioned the American Medical Association, the American Microscopical Society, and the Illinois State Microscopical Society. He was also a member of the committee for the World's Fair from the American Microscopical Society. He was president and lecturer at the American Dental College of Chicago, and lectured frequently at educational assemblies at Chautauqua, Lake Bluff, and elsewhere.

His death occurred March 1, while engaged in a series of lectures at the Chautauqua assembly at Fumale, in Florida. Personally and socially the Doctor was genial and companionable. He was generous in his assistance, an assertion nearly every member of this society can substantiate. He was never too busy or too weary to give his assistance or advice to any of his associates who came to him.

He died in the prime of life, with a splendid record of completed work, together with many plans and purposes into which he had entered, and some of which will yet ripen into fruitage through others.

*Resolved*, That in the death of L. D. McIntosh the Illinois State Microscopical Society has lost one of its most esteemed members.

In the prosperity of its purposes he was earnestly interested, and on many occasions generously contributed his valued services. During his membership, his impaired health, which was unequal to the great demands upon it, prevented him from taking so active a participation in our work as he wished and for which he was so well fitted.

In the varied lines of optical work, he has left a record of valuable effort, and we deeply regret that he was taken away in the prime of his accomplishment.

*Be it also resolved*, That a copy of these resolutions, together with accompanying sketch of Dr. McIntosh, be spread upon the minutes of this society, and a copy also be presented to the AMERICAN MICROSCOPICAL JOURNAL, and a further copy be furnished to his family.

---

Dr. Justin R. Hayes.—*Resolved*, That the Illinois State Microscopical Society greatly deplores the loss of Dr. Justin R.

Hayes, one of its oldest and most esteemed members, and father of Plym S. Hayes, former president of the society.

Dr. Justin Hayes' membership extended previously to the great fire of 1871. He was always an active and zealous member, doing all possible to assist the society and cause of microscopy. He was of special service in assisting the society in entertaining the American Microscopical Society some years since.

He was regular in attendance upon meetings until the infirmities of years compelled him to desist, and his wise counsel and assistance were always highly esteemed.

While not himself an expert microscopist, he always desired the best knowledge of the science, and was interested in its promotion to the very last.

---

### MICROSCOPICAL NEWS.

---

**Leidy's Microscopes.**—Those familiar with the life-work of the late Dr. Joseph Leidy will be interested to know that the two microscopes which he used for years and from which he obtained such valuable results are now for sale. They were bought in 1875, and were in almost constant use down to the date of his death. They show how careful a student he was, in that they are in perfect order and very little soiled or scratched. The outfit consists of one Beck Popular Binocular Stand, complete; two pair eye-pieces; substage condenser; polariscope; liberkuhne; Wenhan's Parabolic Reflector;  $\frac{1}{4}$ -inch objective; stage forceps and plain forceps; one Beck National Stand, monocular, complete, with movable top stage; bull's-eye condenser on stand with universal movement; two eye-pieces;  $\frac{1}{2}$ -inch objective (best series);  $\frac{1}{10}$ -inch immersion objective; camera lucida; polariscope.

Mrs. Jos. Leidy has placed the articles in the hands of Messrs. Williams, Browne & Darle, Philadelphia, who will be pleased to show them to any one desiring to see them.

**H. L. Tolman** sails for Europe, July 6th, on the *Teutonic* to visit the microscope manufacturers, such as Powell & Lealand, Crouch, Zeiss, Reichert, Leitz, Watson & Nachet, as the representative of the World's Columbian Exhibition. He hopes to secure exhibits from the most of them. He will contribute articles to our columns relative to what he sees of interest to microscopists.

**The Key to Algæ and Desmids** which was projected some months ago and advertised conditionally upon a sufficient number of subscriptions being obtained has been abandoned as impracticable at the present time.

**Prize.**—The publisher of the *International Journal of*

*Surgery* offers a prize consisting of one of R. & J. Beck's microscopes with accessories worth \$40 for the best paper on any subject pertaining to surgery or gynaecology.

### CORRESPONDENCE.

Allow me to extend my congratulations to you for successfully moving against a senseless competition. I predict an extension of circulation for both periodicals.—*Chas. Mitchell, M. D.*

### MICROSCOPICAL SOCIETIES.

SAN FRANCISCO, CAL.—W. E. LOY, *Sec'y.*

*April 6, '92.*—The regular fortnightly meeting was held at its rooms, at 432 Montgomery street. President Breckenfeld occupied the chair, and after the routine business the annual address of ex-President Wickson was read. This address reviewed the work of the society for the past year, which has been the most active one in its history, at least in the last decade. Twenty new members were elected, a larger number than the gain of any two previous years.

The paper of the evening was prepared and read by Henry G. Hanks, "On a Specimen of Limonite in the Form of Mock Gold." The specimen was brought from Bald Mountain, White Pine county, Nev.

During the discussion which followed the reading of this paper, Mr. Hanks stated that limonite had no commercial value. It could be used as a pigment, but the same color could be produced with far less expense from other mineral substances.

Dr. Wythe exhibited some faithful drawings of the structure of the voluntary muscular fibre, made from the muscles of the crab, which had been hardened in absolute alcohol. The drawings showed that the muscle is not composed of alternate beads, as popularly supposed. The specimens from which the drawings were made had an amplification of 1,200 diameters.

George Otis Mitchell exhibited a rare polyzoön, a species of *Lophopus*, probably *L. crystallina*, found by him recently in a small pond near San Juan, San Benito county. This beautiful animal is figured and described in Allman's work, published in England about twenty-five years ago; but it has always been considered a British species. This discovery was very favorably commented on, and it was considered a matter of congratulation, not only to Mr. Mitchell, but to the society as well, that so rare and beautiful a species should have been discovered in California.

The society's library was augmented by the donation of a volume of the Louisiana State Board of Health report from Charles C. Riedy, containing an early and rare account of investigations into yellow fever germs; by the first three volumes of the *Amer-*

*ican Journal of Microscopy*, by purchase, and by various periodicals and pamphlets. The donations to the cabinet included gold ore, calcined, from the Diadem mine, Plumas county, presented by J. A. Edman, and a beautiful specimen of stalactitic limonite from Henry G. Hanks.

*April 20, '92.*—The regular conversational meeting was held at 432 Montgomery street, the attendance was good and the exhibit of objects was well received. President Breckenfeld made the visitors welcome in a few words, and stated that the object of these exhibitions was to awaken in the community an interest in natural history as revealed by the microscope.

The exhibits were arranged by the committee so that each exhibitor illustrated some particular subject. Mr. Breckenfeld showed various fresh-water polyzoa, algæ, and larvæ. R. H. Freund had various forms of bacteria, as the bacillus of Asiatic cholera, erysipelas, etc. Henry C. Hyde exhibited various chemical crystals, by the aid of polarized light. L. M. King's exhibit was illustrative of vegetable structure, and included some very pretty sections stained. William E. Loy showed various insect parts, and an entire *Cimex lectularius*. George Otis Mitchell exhibited various anatomical preparations, injected and stained, from man and lower animals. Charles C. Riedy had an interesting exhibit of diatoms, recent and fossil, including *Coscinodiscus astromphalos* under one-twentieth objective, 1,000 diameters.

The next public exhibition of the society will be a "ladies' night," to which the wives, daughters, and lady friends of members will be invited.

### NOTICES OF BOOKS.

*The Atlantic Monthly for June, 1892; Houghton, Mifflin & Co.*—The June *Atlantic* opens with a noteworthy article on "The Education of the Negro," by Dr. William T. Harris, Commissioner of Education, which is enriched with comments by eminent Southern gentlemen—Senator Gibson, Hon. J. L. M. Curry, Philip A. Bruce, Esq., editor of the *Richmond Times*, and Lewis H. Blair, Esq., of Richmond. There is another installment of the "Emerson-Thoreau Correspondence," written at the time Mr. Emerson was in Europe, and abounding in passages delightfully characteristic of both writers. Agrippina, a fortunate and aristocratic cat, is the subject of a charming and very bright essay by Agnes Replier. Janet Ross contributes a paper. Fenollosa writes comparing "Chinese and Japanese Traits." W. H. Bishop contributes "An American at Home in Europe." Olive Thorne Miller furnishes a bird story, "The Witching Wren." In "The Discovery of a New Stellar System" Arthur Searle describes the results of observations on the star Algol and its variations of light. An essay on Walt Whitman speaks of him very justly and discriminatingly both as a man and a poet.



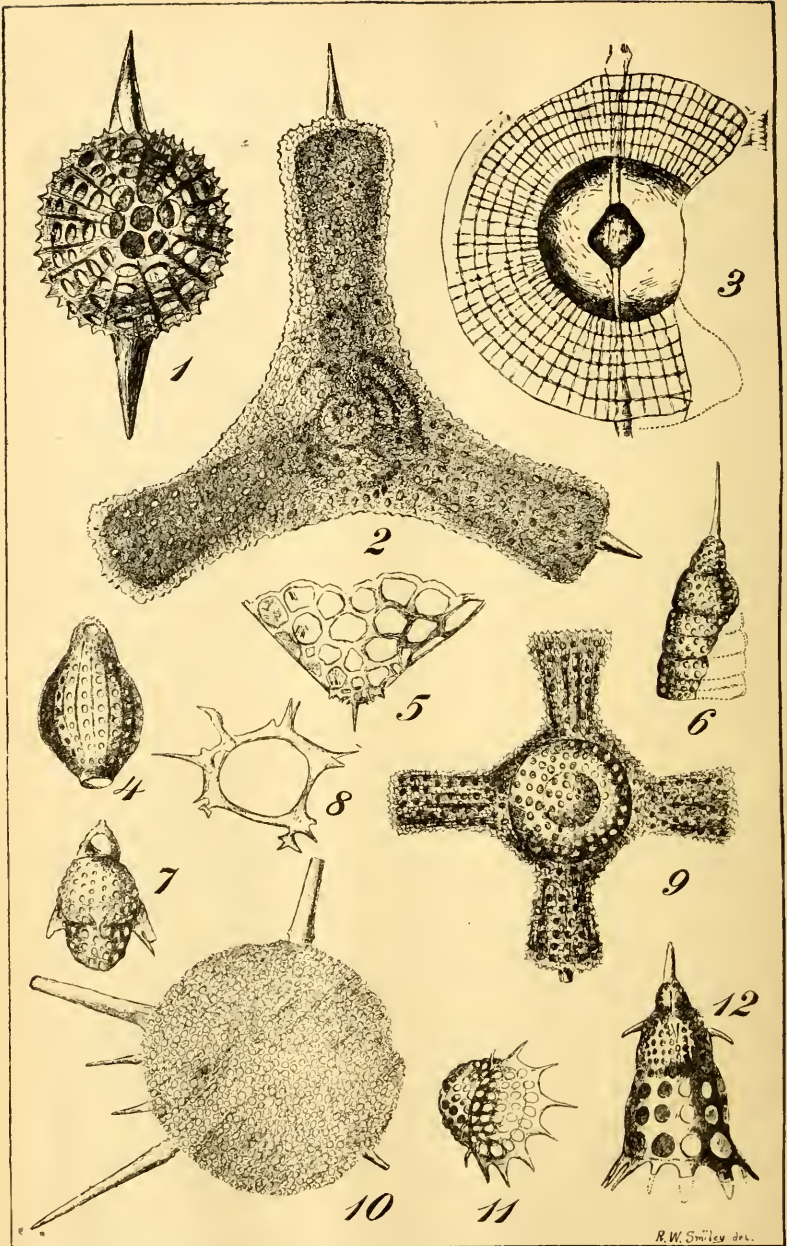

RADIOLARIA.



# THE AMERICAN

## MONTHLY

# MICROSCOPICAL JOURNAL.

VOL. XIII.

AUGUST, 1892.

No. 8.

### CONTENTS.

<p>Radiolaria: Their Life-History and Their Classification. — CARTER (Illustrated) - - - 177</p> <p>A Simple Refractometer.—O'CON- NOR - - - - - 181</p> <p>Diatoms of the Connecticut Shore.—I—TERRY - - - - 185</p> <p>EDITORIAL.—Microscopy is a Science. The Microscope and a Hair - - - - - 190</p> <p>MICROSCOPICAL APPARATUS.— A Convenient Sterilizer (Illus-</p>	<p>trated). Zentmayer's Ameri- can-Continental Stand (Illus- trated). A Microtome for 50 cents - - - - - 192</p> <p>MICROSCOPICAL MANIPULATION. — Examination of Cements. Mounting Trichinæ. Gum for Slide Labels - - - - - 195</p> <p>CORRESPONDENCE - - - - - 198</p> <p>MICROSCOPICAL SOCIETIES.— Lincoln. Nyack - - - - - 198</p> <p>NOTICES OF BOOKS.—Zimmer- mann. Paquin - - - - - 200</p>
-------------------------------------------------------------------------------------------------------------------------------------------------------------------------------------------------------------------------------------------------------------------------------------------------------------------------------------------------------------------------------------------------------	-----------------------------------------------------------------------------------------------------------------------------------------------------------------------------------------------------------------------------------------------------------------------------------------------------------------------------------------------------------------------------------------------------------------------------------

## Radiolaria: Their Life-History and Their Classification.

BY REV. FRED'K B. CARTER,

MONTCLAIR, N. J.

[Continued from page 145.]

We come now to the

### CLASSIFICATION.

Let me say at the outset that it is not my aim to be strictly accurate. While the scheme is taken from Hæckel it omits many points given by him and will not serve to distinguish the forms in all cases. No one can be more conscious of its deficiencies than myself, and I shall be only too glad to have any one improve upon it. At the same time I believe that it is correct as far as it

goes and that it will be of service to the beginner, helping him to gain enough knowledge of the classification to lead him to consult Haeckel's work itself if he finds the subject interesting. The trouble with the strictly accurate key is that it is apt to be so full as to discourage the beginner, especially if he has but little time to devote to microscopical study. I am judging others by myself and venturing to put before them what has proved helpful to me. But if in any case the student finds himself at a loss let him go to work in turn and make a better scheme for the good of his fellows, at least so far as to remedy the defect in that particular. Trusting, therefore, that the readers of the JOURNAL will understand my purpose and make all allowances, I shall try to give the more important points of the classification as far as I have been able to make them out.

In the number of the JOURNAL for January, 1888, I mentioned these four orders of *Rhizopods*, namely,

The *Protoplasta*,  
The *Heliiozoa*,  
The *Radiolaria*,  
The *Foraminifera*;

and I said that these four fell again into two main subdivisions, founded on locality, namely, the fresh-water and the marine Rhizopods; the *Protoplasta* and the *Heliiozoa* forming the first, the *Radiolaria* (including the *Polycystina*) and the *Foraminifera* forming the second section. I remarked further that it would take us too far to enter into the minor classification of the marine Rhizopods. Little did I dream then how huge the marine subdivision was, my meaning being simply that the fresh-water forms were sufficient for our purpose at that time. Even when I decided to write on the marine section it seemed to me that it would be feasible to treat of both the divisions in that section in one article. At any rate I thought the *Radiolaria* could be disposed of in short order, and the Micrographic Dictionary encouraged the idea, as it gave but *half a column* to the *Radiolaria* and scarcely a dozen figures of the genera. Even Carpenter, while he enlarged very considerably on the Micrographic's meagre account, gave but little space to the *Radiolaria* as compared with the *Foraminifera*. So that I was totally unprepared for the facts as revealed by the latest edition of the Encyclopædia Britannica. The moment I glanced over the description there I saw that it would be useless to attempt to take both the *Foraminifera* and the *Radiolaria* at the same time, for the Encyclopædia enumerated no less than forty-nine genera of the *Radiolaria* alone, and even these it said were *selected*. And then when I gained access to Haeckel's splendid work I was amazed beyond all bounds and ready to drop the whole subject, for he stated that the number of genera was no less than 739 with over 4,000 species! This, I am sure, will surprise some of you as much as it

did me, especially when you compare the number of genera of the *Radiolaria* with those of the fresh-water *Rhizopods* (both orders included) or of the *Desmids* or *Diatoms*.

The genera of the fresh-water *Rhizopods* described by Leidy  
 number ..... 30  
 Of the *Desmids*, as given by Wolle..... 19  
 Of the *Diatoms*..... 125  
 While the *Radiolaria* alone, as given by Haeckel, number 739

It was enough to frighten one to think of attacking that huge host. In fact, I was so totally unprepared for anything of the sort by the books at my command, that I was perfectly dazed when the librarian handed me three bulky quartos, no mean load for a man to carry, *all devoted to this one order of the Rhizopods*. It gave me a wider conception of the infinity of nature than I had ever had before, for which I was thankful, but the first effect was to take all the courage out of me. It was altogether *too big a contract*, and it seemed utterly useless to attempt to offer any scheme of classification for the beginner. But, as I consulted the work, my eye fell upon a statement that reassured me, namely, that of the 4,300 and more species now known, no less than 3,500 were added by the Challenger Expedition, the material of which is not to be obtained, and therefore the species are practically cut down from over 4,000 to some 800 and the genera from 739 to about 162, if I remember right. Indeed, for most of us, they are cut down still further, namely, to those which are to be found in the *Barbadoes earth*, which is the only material at command. Now Ehrenberg found in this deposit about 282 species, which he arranged in some, 42 genera. I decided, therefore, to confine myself to the genera mentioned by Ehrenberg, but making use of the classification of Haeckel, which adds somewhat to the number, a single genus of Ehrenberg being divided by Haeckel into two, three, or more genera. Now this gives us in all some 56 genera, or about the same number as we considered in the case of the diatoms, and reduces the task within bounds, besides being all that it is necessary for any one to know, unless he wishes to study the material from the Nicobar Islands, or is fortunate enough to obtain some of the deep sea dredgings from the South Pacific or South Atlantic. In the North Atlantic these forms are rare. I examined some dredgings at different depths from that quarter before I learned that fact and had my labor for my pains.

These fifty-six genera, then, fall into two great groups, namely :

A. *Peripylæa*.

B. *Monopylæa*.

In the first the *central capsule* is spherical and has pores distributed all over it. In the second it is *conc-shaped*, and only the base of the cone is perforated. Although it is often hard to dis-

tinguish these features of the central capsule, there are marks in the skeleton which correspond, namely, the presence or absence of a large mouth or opening. For when the inner capsule has pores all over it the outer skeleton has also, whereas if there is only one perforated area in the capsule there is, as a rule, a wide opening in the skeleton. Furthermore, the spherical capsule of the first group produces round or disk-like skeletons, the cone-shaped capsule of the second group, cone-shaped skeletons, or modifications of the cone.

If your Radiolarian skeleton then has no large mouth or opening it belongs to the first group, which contains these 20 of the 56 genera:

*Cenosphaera*, *Ethmosphæra*, *Stylosphaera*, *Spongosphæra*, *Haliomma*, *Lithocyclia*, *Stylocyclia*, *Hymenactura*, *Astractura*, *Stauractura*, *Pentactura*, *Echinactura*, *Porodiscus*, *Perichlamydidium*, *Stylodictya*, *Hymeniastrum*, *Histiiastrum*, *Stephanastrum*, *Phacodiscus*, *Periphæna*.

Of these, again, some are spherical and others convex or flat. If your form is a sphere or very convex, it is one of the first five. And these are the distinguishing characteristics; *Spongosphæra* has a spongy skeleton. If there are no radial spines on the surface of the shell it is *Cenosphaera* or *Ethmosphæra*, and pores prolonged into tubules will make it the latter. If there are two main spines opposite in one axis it is *Stylosphaera*. This genus, however, is still further divided by Haeckel, according as the spines are equal or unequal or curved or bent, but Ehrenberg classes them all under *Stylosphaera*. If there are 8 to 12 or more radial spines it is *Haliomma*.

If your form is slightly convex it is one of the next 9 genera. If the shell is lens-shaped and there are no chambered girdles, it is either *Phacodiscus* or *Periphæna*, and a hyaline equatorial girdle will make it the latter.

If the disk has rings divided by radial beams into chambers it is *Lithocyclia*, *Stylocyclia*, *Hymenactura*, or one of the four next and allied genera. *Lithocyclia* has no radial spines, *Stylocyclia* 2 opposite spines. The others have from 2 to 5 hollow radial chambered arms. *Hymenactura* has 3, *Astractura* and *Stauractura* have 4, *Pentactura* and *Echinactura* 5. *Stauractura* and *Echinactura* again are marked by the presence of a connecting structure between the arms.

LIST OF FIGURES IN THE FRONTISPICE.

- |                                                           |                                                             |
|-----------------------------------------------------------|-------------------------------------------------------------|
| FIG. 1. <i>Stylosphaera</i> Carduus.                      | FIG. 7. <i>Lithornithium</i> foveolatum.                    |
| 2. <i>Hymeniastrum</i> ( <i>Histiiastrum</i> ) ternarium. | 8. <i>Lithocircus</i> ( <i>Stephanolithis</i> ) spinescens. |
| 3. <i>Stylocyclia</i> dimidiata.                          | 9. <i>Stauractura</i> ( <i>Astromma</i> ) Aristotelis.      |
| 4. <i>Sethampora</i> ( <i>Eucyrtidium</i> ) Mongolfieri.  | 10. <i>Spongosphæra</i> rhabdostyla.                        |
| 5. <i>Cornutella</i> ampliata.                            | 11. <i>Halicalyptra</i> Galea.                              |
| 6. <i>Eucyrtidium</i> Picus.                              | 12. <i>Pterocodon</i> Campana.                              |

(To be continued.)

### A Simple Refractometer.

By JOSEPH T. O'CONNOR, M. D.,

NEW YORK CITY.

In preparation for a summer to be spent in special investigations in biology, I have used all my spare time during the past few weeks in wrestling with the management of a high-class 1-10 hom. imm. objective from one of the best American makers. In my hands the lens has not done what the makers claim it will easily do and I naturally supposed that the fault lay in my own want of manipulative skill. At the same time I was aware that the immersion fluid (apparently a glycerine compound) furnished by the maker and handed to me by his agent seemed darker than it ought to be and felt that possibly it ought to bear a share of the blame for my ill success. But how should I determine whether or not the fluid was of the proper refractive quality?

Reading, in the November number of *THE MICROSCOPE*, Doctor Stokes' remarks concerning homogeneous immersion fluids and his statement that Prof. H. L. Smith had devised a simple and successful little refractometer but that it was not in the market, I applied to a dealer and by good fortune obtained one. The description of this instrument can be found in the published proceedings of the Society of American Microscopists of 1885. It consists of an adapter that screws onto the nose-piece of the microscope and receives at its lower end an inch objective. Near the upper end of the adapter a slit is arranged (as for a micrometer eye-piece). Through this slit pass, closely pressed together, two plates of crown glass of the same refractive index as that of cover-glass. The glass plates are 2 inches long by  $\frac{1}{2}$  inch wide and about 1-10 inch thick. In the middle of the flat surface of one plate is ground a "concave" to  $\frac{1}{3}$  or more of the thickness of the glass.

A suitable object, being now placed on the stage and lighted, is focused as under ordinary circumstances. Next, two or three drops of the immersion fluid are placed in the concavity, and the other, plane glass slip is brought into apposition over the fluid so that the cavity is completely filled; a small portion runs out to each side as an extremely thin layer, but this Prof. Smith finds to be of no moment. The plates thus in apposition are passed together through the slit in the adapter and it will be found that when the plane surfaces only of the plates are in the pathway of the rays from the objective no sensible change is needed in the adjustment, but when the "concave" is brought into the field a change in adjustment will be needed unless the fluid used was really homogeneous, or, that is to say, of the same refractive index as that of the crown glass. Prof. Smith found that by marking the tube or rack-bar of the microscope a gauge could be made showing the amount of adjustment needed for fluids of different refractive indices, and thus, by interpolating, the refractive index of an unknown fluid could be determined.

In my use of this instrument I found the difference between water and homogeneous fluid to be some six divisions of the rack-bar, and between the homogeneous fluid first referred to and another it was one division. It was extremely difficult to observe such a small difference in the dim light about the tube. But a more serious objection was in the fact that when the adapter screwed "home" the slit was "fore-and-aft," and as I used a  $\frac{2}{3}$  objective (not having a 1-inch) in racking up to get the right focus when the fluid was in the field, the glass slips projected backward, caught under the body of the microscope, and with a little more upward motion would have been broken. Professor Smith's illustration, as given in the report referred to, provides, however, for this, as the "concave" is there made near one end of its slip and not in the middle. I have another microscope with a rifle-screw for the coarse adjustment and with a  $\frac{2}{3}$  or  $1\frac{1}{2}$  inch objective the refractometer could not be used on it. It seemed to me that the principle involved in Prof. Smith's device could be applied in a readier manner. A little consideration by any one acquainted with the simpler optical principles of the action of lenses will show him that the concave acts by itself as a plano-concave lens, and that when the concavity is exactly filled to the plane surface with a substance having the same refractive index as the glass, it is virtually restoring the material that made the slip at first before the concave was ground out, a plane glass slip with parallel faces. Now the simple method adopted by oculists in determining whether a spectacle glass is concave or convex is to hold it 18 inches or two feet from the face and view through it any rectangular object 10 or 12 feet distant. If when thus viewing such an object the glass be moved from side to side or up and down, it will be found that in the case of a concave lens the object (part of a window sash) will be seen to move with the lens, while with a convex glass it will appear to move in a direction opposite to that given to the lens. A glass with plane parallel surfaces gives no apparent motion to the object when moved itself.

Experiment in this way with the first homogeneous immersion fluid did not restore the refractive property to the concavity filled with it, but in order to neutralize the concave action still left, a convex lens of 40 inches focus had to be placed in flat contact with the slip. Measurement of the focal length of a convex lens is done by projecting the image of a distant object upon any suitable surface, the distance between the lens and the image thus formed being the focal length. But it is impossible to measure in any such way the strength of a concave lens, as it has only a so-called negative focus and causes only a virtual image. The oculist in order to determine the strength of a concave lens places in apposition with it, successively, convex lenses of different focal lengths until he finds one that exactly neutralizes the refractive power of the concave lens, and when two lenses, one negative or concave, the other positive or convex, are placed together and

through them an object several feet distant is observed there will be no apparent lateral motion of such object when the combination is moved, if the refractive powers of the two lenses neutralize each other.

It will thus be seen that when the concave in one of the crown-glass slips is filled to the plane surface (and to keep the fluid at such plane is the only function of the other, plane, slip) with a liquid of the same refractive index as that of the glass used there is no refractive power left in the apparatus but it acts as two pieces of plane glass. If the fluid used have a refractive index lower than that of the glass the combination is still of negative or concave quality, and when the fluid is of higher refractive index than that of the glass the mass of fluid in the concave has become a convex lens whose focal length decreases, that is, the strength of the lens is greater, in proportion as the refractive index of the fluid is higher than that of the glass.

The following experiments were made and many of them repeated with the same results. Concave equals approximately concave lens of  $\frac{7}{10}$  inch negative focus.

Concave filled with distilled water; refraction negative and requires a convex lens of 10.62 D. for neutralization. The refractive index of water is given as 1.333. The combination equalled a negative lens of 10.62 D.

With absolute alcohol (old specimen)	= - 8.37 D.	R. I.	1.366
“ glycerine “ “	= - 2.75 D.	“	1.4
“ olive oil, good commercial (old specimen)	= - 2.5 D.	“	1.47
“ oil of cedar “ “ “	= - 1.5 D.	“	1.51
“ from a first-class druggist.	= - 3.25 D.	“	?
“ oil of cedar from another druggist	= + .25 D.	“	1.508
“ oil of cinnamon from first-class house.	= + .25 D.	“	1.544
“ oil of fennel “ “ “	= + 1. D.	“	1.53
“ oil of cloves “ “ “	= + 5.5 D.	“	1.626

In the foregoing it will be seen that oil of cedar, obtained from a first-class house, when in the concave did not extinguish the concave refraction, but left a residual amount that needed for complete neutralization a positive lens of 1.5 D.; that is, of about 30 inches focal length. This shows that even the best cedar oil of commerce is not of sufficiently high refractive index for use as an immersion fluid. The next in the list was evidently an impure or adulterated specimen of cedar oil, as its refractive index is shown to be less than that of an ordinary specimen of glycerine.

Oil of cinnamon is given in the table in Carpenter, last edition, as having a refractive index of 1.508, or very nearly, but still less than that of oil of cedar. It therefore ought to show in the concave some residue of concave action; but the specimen used showed

a convex action, requiring for neutralization a concave lens of .25 D. I, therefore, from experiment with my device do not hesitate to say that this specimen of oil of cinnamon was adulterated with, probably, oil of cassia, whose refractive index is seen in the table to be much higher.

With oil of fennel and oil of cinnamon there was an evident prismatic effect, color dispersion being well observed at the edge of the concave. With oil of cloves this was much more marked, and with oil of cassia the prismatic colors were so intense as to impair the view of the window sash.

With homogeneous immersion fluids or fluids sold as such, I had equally interesting and confirmatory results. The first one already alluded to gave, as has been stated, negative refraction requiring a convex lens of 1. D. for neutralization. It is better than commercial cedar oil, but I fear its index is too low for effecting the best results with a homogeneous immersion lens.

Messrs. J. W. Queen & Co.'s homogeneous immersion fluid absolutely neutralized all refractive influence of the concave when viewing a window frame 6 or 8 feet away. When viewing an object 100 or 150 feet distant there was evident on close observation a slight degree of convex lens action, requiring for neutralization a concave lens of .12 D. As the focal length of this lens is somewhere about 288 inches, or 24 feet, it will be seen that the variation of the index of this fluid from that of the glass is practically *nil*, and moreover the variation is a convex one, which is an advantage.

✓ Messrs. Bausch & Lomb's hom. imm. fluid is also practically homogeneous. Viewing through the device filled with it a window frame 6 or 8 feet distant, the faintest apparent motion in opposite direction (that is, a convex-lens action) could be made out, while the apparent opposite motion of an object thus viewed at a distance of 100 or 150 feet, while evident, was slight, requiring a concave lens of .25 D. for complete neutralization. This fluid thus is practically homogeneous and the variation is in the right direction.

A specimen of thickened cedar oil sent out for use with hom. imm. objectives by a celebrated English firm of microscope makers had a refractive index less than that of the glass in my device, requiring for neutralization a convex lens of greater strength than .25 D., a .5 D. being too strong; we might take the mean and estimate the residual concave action in using this fluid as 37 D. The variation is in the wrong direction.

It must be borne in mind that the foregoing experiments and the deductions therefrom, excepting always the loss of parallax if the fluid is homogeneous, are based upon the individual slips of glass and the negative focus of concave actually used. An extension of the number of fluids thus tested would enable us to gather data from which might be constructed a mathematical curve from which we could determine, by the method of interpo-



lation, the actual refractive index of any fluid. Another slip with a concavity of different curvature would give results differing in the strength of the correcting lenses and producing a different mathematical formula without, however, altering essentially the final results. It must be remembered also that crown glass itself varies in refractive index in different specimens from 1.51 to 1.53, and hence an optician may send out an absolutely homogeneous fluid when tested by his crown glass and yet it might show a refractive index a little too low or a little too high when tested with another specimen of crown glass. Prof. Smith says that an absolutely homogeneous fluid cannot be obtained, but what may be accepted as allowable variations from a theoretical homogeneity in such fluids when used with immersion lenses could be decided only after further experimentation; it seems to me that a variation, using the device I have described, requiring a plus lens of 1. D. for neutralization or possibility of more than .5 D. should condemn the fluid as unworthy of use with high-angled objectives.

51 WEST 47TH ST., NEW YORK, June 10, 1892.

NOTE. —The D. in the foregoing is the abbreviation for Dioptry, the unit of "strength" of spectacle lenses. A dioptry equals 1 meter or approximately 40 inches. A spectacle lens of 2 dioptries is twice the strength of a lens of 1 dioptry—that is, it has a focal length of 20 inches. To ascertain the focal length of any lens designated in dioptries divide 40 by the designating number and the result is obtained in inches. Thus a lens of .25 dioptry should be of 160 inches focus, but many opticians in the U. S. do not adhere strictly to the true dioptric measurements in lenses of very long focus, and the lenses marked .25 D. in the trial set used in the above tests are really only of 144 inches focus. The .12 D. used is of double that focal length.

When the plus sign is used it applies to convex lenses; the negative sign signifies concave lenses.

---

## Diatoms of the Connecticut Shore.—I.

BY W. A. TERRY,

BRISTOL, CONN.

In a paper published in this periodical December, 1888, I gave a brief account of the results of a search for diatoms on a small section of the Connecticut shore near New Haven, and mentioned particularly several forms new to me, and which the aid of experts had not at that time enabled me to determine. In a review of this paper in a subsequent number of the *Torrey Bulletin*, Prof. Kain expresses the hope that I will follow this account with a complete list of all the varieties found. I should have been glad to have done this, but, unfortunately, the complete literature of

this subject was not accessible to me; and as many of the forms were unfamiliar, and the reports of many experts to whom they were submitted were so incompatible, I did not like to pronounce upon them myself. I found what appeared to be an obstinate determination on the part of some not to admit the possibility of any new discovery, and an equally determined opposition to any revision of existing genera. This seems to me as unreasonable as it will be futile, particularly as regards the *Navicula*; for even if Prof. P. T. Cleve's new revision is not accepted in full, some other must be soon. Many valued correspondents write me that they fear that the separation of the *Navicula* into new genera and species will result in confusion, and complicate the study. Precisely the opposite effect may be expected, for if the new genera have obvious characteristics, the study and the determination of unfamiliar forms will be greatly simplified.

In his introduction to his recent "Monograph of the Genus *Pleurosigma*," Peragallo remarks: "The genus being well defined remained in spite of the opposition of Ehrenberg. That stupefying micrographer, who on his own part multiplied beyond all measure the genera and species upon the most frivolous characteristics, not only would never admit the genus of Smith, but also united almost all its species under the name of *Navicula sigma*." It is not likely that the present opposition to revision will be any more effective than that of Ehrenberg. Feeling satisfied that the varieties in question had been previously undescribed, I sent slides to some of the most eminent specialists of Europe. They reported all the forms *new*, that they had been named and would be described and illustrated in monographs of different genera soon to be published. Three of the *Pleurosigma* of Morris creek appear in H. Peragallo's excellent "Monograph" published in late numbers of *Le Diatomiste*. The description is as follows:

*Pleurosigma Terryanum*. H. P. (Balticum var?).

In a very fine collection of Mr. Terry coming from marsh, South End (Connecticut), and which will be published in the series Tempère and Peragallo, is found very frequently a form which has the general appearance of the strigitis and the striation of the Balticum. 15.5 stria in 10 u. Length 0.400-0.450, width 0.038-0.041. Pl. vii, f. 21.

*Pleurosigma decorum*. Sm. (var?) Americanum, H. P.

Larger than the type, raphe less eccentric, striation according to type, silica more delicate. Dike creek. W. A. Terry. Pl. I, f. 9.

*Pleurosigma paradoxum*. H. P.

A little smaller and less finely striated than the preceding (*P. culinarum* Grun). Striæ oblique 20-21, transverse 18-19.

The latter less visible though more separated than the oblique. Numerous measurements leave me no doubt upon this point. Abundant in a gathering from Morris creek by Mr. Terry. Pl. v, f. 13.

*Pleurosigma Terryanum* was the larger form mentioned in previous article, and was found in a small pool in the salt marshes of Morris creek; thorough search over several miles of neighboring marsh and water failed to find a single specimen elsewhere, but I have since found what appears to be the same variety in a ditch in the salt meadows of the Quinnipiac river, about eight miles distant. A small shallow pool on the opposite side of Morris creek contained *P. strigosum*, with *Surirella striatula* and *S. regina*; another neighboring pool had abundance of *P. elongatum*.

*Pleurosigma Americanum* was found in the creek, and I have since found it in Stony creek and in Leetes' Island creek. It is most likely to be mistaken for *P. elongatum*, although very distinct aside from the striation. Dry mounts from a gathering from Stony creek show both forms side by side, and the characteristic differences are easily seen in the dry valves. *P. Americanum* is much larger and more robust, deeper in color, median line eccentric and lighter in color than the rest of the valve. *P. elongatum* appears pale, thin, and flattened, median line more nearly central and darker in color than the valve. *P. paradoxum* is also found in the creeks.

The *Actinocyclus* of Morris creek is *A. Barkleyi*. I find this in many other sections of the Connecticut shore, in the Thames river as far up as Norwich, and many points on Atlantic shore to as far south as Florida, but the most abundant station is Morris creek. This and many others mentioned in this paper do not appear in "Wolle's Diatoms of North America."

The small pools frequent in the salt marshes appear to be the remains of former open water, which has been filled up by sediment and encroached upon by vegetation until only shallow pools remain. These are almost without exception rich in diatoms, and most of them contain abundance of the larger type of *P. Balticum* and very numerous varieties not often found elsewhere. The salt marshes of Connecticut occupy the beds of ancient estuaries, and in all which I have examined below the surface peat is found a deposit of clay and sand containing diatoms. This deposit is sometimes more than thirty feet thick and is horizontally stratified in thin lamina in which the diatoms are very unequally distributed; contiguous strata frequently contain entirely different forms, and below four feet depth they are generally deep water marine forms, without admixture of brackish and shallow water forms, so abundant at the top. These deposits, though not as ancient as those of Maryland and Virginia, will still date back to glacial times, being probably the only fossil marine deposits in New England. Of the very interesting varieties found in these deposits I shall have more to say hereafter.

The following determinations I quote from the series of J. Tempère and H. Peragallo, though as they were made from small samples of single gatherings they cannot show anything like the

number of varieties found in my numerous and systematic gatherings made at that time.

No. 240. NEW HAVEN HARBOR (CONNECTICUT).

This gathering was one of the series of soundings described in my former paper, and was taken from a depth of about twenty feet of water at the entrance to Morris Cove, about half a mile south of Fort Hale.

Actinocyclus crassus Sm.	Navicula formosa Greg.
Actinoptychus undulatus E.	Navicula — var. A. S. 50 ff. 10. 14. 15.
Auliscus pruinosisus Grev.	Navicula fusca Greg.
Auliscus " — var. zanzibarica Grun.	Navicula Henedyi var. manca.
Amphora intersecta A. S. var.	Navicula Humerosa Breb.
Biddulphia aurita Breb.	Navicula interrupta K.
Biddulphia rhombus Sm.	Navicula latissima Greg.
Campylodiscus Echeneis E.	Navicula lyra E.
Cerataulus turgidus E.	Navicula " — var. elliptica.
Coscinodiscus apiculatus E.	Navicula polysticta Grev. var.
Coscinodiscus excentricus E.	Navicula praetexta E.
Coscinodiscus oculus iridis E.	Navicula Smithii Breb.
Coscinodiscus radiatus E.	Nitzschia acuminata Sm.
Cyclotella striata (K) Grun.	Nitzschia circumscuta Bail.
Melosira sulcata K.	Pleurosigma affine Grun.
Melosira " — var. coronata.	Raphoneis amphiceros E.
Navicula approximata A. S. var.	Rhabdonema adriaticum K.
Navicula Baileyana Grun.	Surirella fastuosa E.
Navicula caribaea Cl.	Triceratium favus E.
Navicula forcipata Grev.	Tryblionella Hantzschiana Sm.

No. 241. MORRIS CREEK (CONNECTICUT). No. 1.

This gathering and the following No. 2 were from soundings in Morris creek, taken at points about half a mile distant from each other.

Actinocyclus Barkleyi Grun.	Navicula lyra E.
Actinoptychus undulatus E.	Navicula lyra — var. A. S. 2 f. 25.
Amphiprora pulchra Bailey.	Navicula pusilla Sm. var.
Amphora Euleinsteinii Grun. var.	Nitzschia circumscuta Bailey.
Coscinodiscus lineatus E.	Nitzschia scalaris Sm.
Cymbella gastroides var. crassa.	Pleurosigma affine Grun.
Melosira Borreri Grev.	Pleurosigma balticum Sm.
Melosira sulcata K.	Pleurosigma strigosum Sm. var.
Navicula distans A. S.	Surirella striatula Turpin.
Navicula formosa var. A. S. 10 f. 15.	Tryblionella Hantzschiana Sm.
Navicula interrupta K. var.	

No. 242. MORRIS CREEK. No. 2.

Actinoptychus undulata E. var??	Mastigloia Grevillei Sm.
Amphiprora pulchra Bailey.	Navicula brevis Greg.
Amphiprora maxima Greg.	Navicula crucicula Sm.
Amphora Euleinsteinii var.	Navicula rhyncocephala K.
Coscinodiscus excentricus var.	Nitzschia scalaris Sm.
Cyclotella striata K.	Nitzschia sigma Sm.

Nitzschia sigmaidea var.  
 Navicula elliptica K.  
 Navicula elegans Sm. var. *avec les  
 extremites capitees.*  
 Navicula formosa Greg.  
 Navicula fortis Greg.  
 Navicula interrupta K.

Navicula major K.  
 Navicula peregrina E. et. varieties.  
 Navicula rhombica Greg.  
 Pleurosigma Balticum Sm.  
 Pleurosigma Terryanum H. P.\*  
 Synedra pulchella K.  
 Triceratium alternans Bailey.

No. 244. (*Marsh\**) SOUTH END.

Actinocyclus Barkleyi Grun.  
 Actinoptychus undulatus var.  
 Amphiprora pulchra Bailey.  
 Amphiprora maxima Greg.  
 Amphora Euleinsteini Grun. var.  
 Coconeis scutellum E.  
 Coscinodiscus excentricus E.  
 Coscinodiscus oculus iridis E.  
 Coscinodiscus radiatus E.  
 Cyclotella stylorum Br.  
 Epithemia musculus K.  
 Melosira Borreri Grev.  
 Navicula brevis Greg. var. elliptica.  
 Navicula cruciferum var.  
 Navicula elliptica K.  
 Navicula formosa Greg.  
 Navicula fusca var? A. S. 7 f. 7.  
 Navicula humerosa Breb.

Navicula interrupta K.  
 Navicula peregrina E. et var.  
 Navicula zostereti Grun.  
 Nitzschia acuminata Sm.  
 Nitzschia scalaris Sm.  
 Nitzschia sigma Sm.  
 Nitzschia Tryblionella Grun.  
 Pleurosigma affine Grun.  
 Pleurosigma balticum Sm.  
 Pleurosigma Americanum H. P.\*  
 Pleurosigma delicatulum Sm.  
 Pleurosigma. *Sp. n. intermediaire  
 entre le Pl. obliquum Grun. et la  
 petite variete du Sincude E. Sera  
 ulterieurement decrit.*  
 Pyxilla baltica Grun.  
 Surirella striatula Turpin.  
 Triceratium (Lithodesmium) undu-  
 latum E.

—o—

**Sectionizing Hydra Viridis.**—About five years ago I tried the experiment of growing the hydra from sections. I cut a large and vigorous specimen into about ten pieces, and placed them in a small test-tube with water drawn from the household tap; in two or three weeks, eight out of the ten pieces had developed in full-grown vigorous hydræ. Of course I was careful to exclude all such things as cypris and cyclops, and everything that seemed likely to prey upon the undeveloped sections, and also allowed plenty of water, so that there was no risk of the oxygen becoming exhausted, a rather important feature where animal life is concerned, either in development or prolongation.—*F. J. George, in Science-Gossip for August, 1892.*

\*By some error this is printed (Bristol) and *P. Terryanum* and *P. Americanum* are transposed, *P. Terryanum* having been found only in the small pool before mentioned, from which this "South End" gathering was taken. *P. Paradoxum* was found in another gathering from Morris creek, and many other forms appear in other gatherings beside those mentioned.

I have sometimes been surprised to see old collectors, who should know better, attempt to describe the diatomacæ of a section or a body of water from a single gathering. A fossil deposit varies greatly in the varieties shown in different strata, and even the same stratum will show a collection of entirely different forms within a short distance of each other.

The reason of this is easily seen by any one who studies the distribution of living forms. The centre of a creek or inlet will generally show different varieties from those found on the margin, and very different forms may be found on the margin of a pond within a few feet of each other.

Some time since a friend sent me a sample of mud from one of the small lakes of Indiana; it contained abundance of *P. attenuatum*; wishing more, my friend sent me another sample gathered by the same man from same place; this had no *Pleurosigma* but was rich in *Surirella craticula*. Wishing to study the relation between this and *Navicula cuspidata*, which was also abundant, I sent for a third supply; this did not contain a single specimen of *P. attenuatum* or *S. craticula*, but *N. Americana* was plentiful, which did not appear in either of the other gatherings.

BRISTOL, CONN., May 20, 1892.

**EDITORIAL.****MICROSCOPY IS A SCIENCE.**

By microscopy is here meant the special learning relating to the construction and use of the microscope and of its various accessory apparatus. The microscope is not a simple tool but a complex and delicate mechanism around which a vast mass of special learning has been accumulating for many decades; this special knowledge has already assumed an orderly arrangement, and the ultimate principles on which the various manipulations are founded have been generalized to such an extent as to fairly entitle microscopy to be ranked as one of the sciences. To be properly studied, objects must first receive more or less special preparation, and the necessary knowledge can only be acquired by patient study. Almost all of the technical processes of microscopy as used in distinct lines of research have much in common with each other. The same microtome and turn-table, staining and mounting, and finishing media, the same slides and covers and labels and forceps and needles, are used in many different researches. But the knowledge is the same, it is certain, it has been verified and systematized, and it is such in quantity as to amount to a science.

Search the encyclopædias and dictionaries with care, and find, if possible, a definition of science which will not fairly include what is above-described as the Science of Microscopy.

Chambers' Encyclopædia defines a science "as the name for such portions of human knowledge as have been more or less generalized, systematized, and verified." Generality as opposed to mere particulars, system as opposed to random arrangement. The quality of the knowledge is of more consequence than the quantity. Theoretical and practical sciences are distinguished.

Theoretical science embraces a distinct department of nature, and is so arranged as to give in the most compact form the entire body of ascertained knowledge in that department. Such are Mathematics, Chemistry, Physiology, Zoology, etc.

A practical science is the application of scientifically ascertained facts and laws in one or more departments, to some practical end, as for example, Navigation, Engineering, Mining, Medicine, etc. True it is that microscopy does not embrace any one department of Nature, but it is most certainly an "application of scientifically ascertained facts and laws in one or more departments to some practical end," the end always being to render some definite natural object (by technical manipulation) available for the purposes of study or of vision.

Webster says that an art is that which depends on practice or performance, and science that which depends on abstract or speculative principles. The theory of music is a science, the practice of it an art.

Suppose by these definitions we test the claim of microscopy to be called a science. While the theory of microscopy as contained in its journals and in the proceedings of the microscopical societies and in the rich library of works upon the various branches of microscopical technique is a science, the practice of microscopy by the bacteriologist, the zoologist, the chemist, the entomologist, the mineralogist, the pharmacist, etc., is an art. There is a science of microscopy, and in its practical applications as an art it has given birth to an ever widening circle of sister arts, each of which is the ready handmaid of some particular branch of knowledge.

If any one should ask whether or not there exists any collection of the general principles or leading truths relating to the manipulation of microscopical apparatus, the many treatises and publications at our call will be a full and sufficient answer. Take, for example, such a finished work as Dr. James' "Technical History of a Slide," and who would assert that this masterly little treatise is not a collection of general principles and leading truths, arranged in an orderly and scientific manner, and that it does not render our knowledge of how properly to mount a slide "certain," or deny that by its aid the mind acquires full comprehension and understanding of the truths and facts which pertain to microscopical technique?

The special knowledge concerning the use of any tool or machine, if of sufficient importance to be generalized, when properly generalized becomes a science, while the application of these scientific principles in the practical use of the machine or tool becomes an art. Manifestly the more complex the mechanism, and the more wide-spread its practical applications, the more justification for generalizing the special knowledge peculiar to the machine, and elevating it to a science. Microscopy arrived at that point long ago.

**The Microscope and a Hair.**—Two different men were suspected of making an assault but no proofs were forthcoming. A single hair which was found on the clothes of the victim finally became the clue to the mystery.

The hair was photomicrographed and compared with photomicrographs of the beard and hair of each suspect. There was entire lack of similarity and the case was about to be abandoned. The hair was pointed and had never been cut. Other facts pointed to its belonging to a smooth-haired and comparatively short-haired dog. Inquiry revealed the fact that one of the suspects owned such a dog. A fresh hair agreed in every respect with the specimen. The owner of the dog could not explain away the facts and was convicted. He also confessed to having committed the assault.

**MICROSCOPICAL APPARATUS.**

**A Convenient Sterilizer.**—Mr. Adolph Levy, chemist, of 145 Grand street, Brooklyn, N. Y., sends to us the following description of his invention :

The present demand of sterilization of instruments and dressings at surgical operations (in private practice at the residence of the patient) and the necessary inconvenience of carrying a heavy or cumbersome apparatus induced the writer to transform an ordinary farina boiler made of extra heavy tin with copper bottom for this use. It is in use with many active surgeons who regard it as an efficient and useful adjunct in conducting major operations, where antiseptic precautions are necessary.

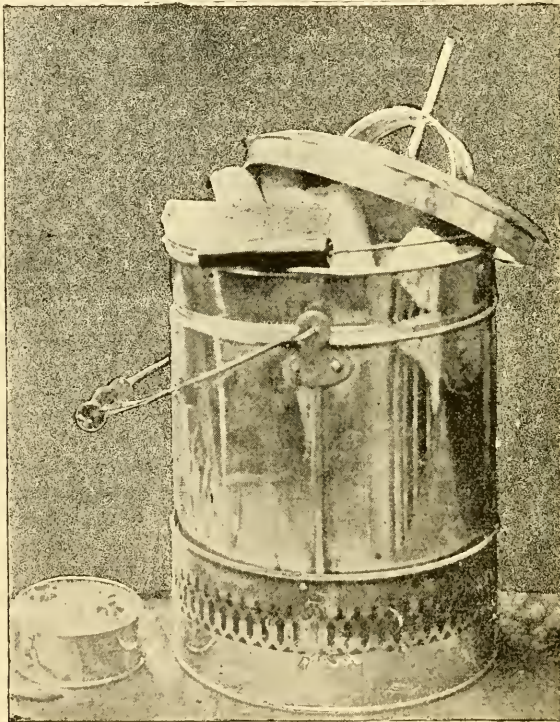

A Convenient Sterilizer.

A six-quart farina boiler composed of two parts, the outer to contain the water (about 3 inches in height), bringing it within one inch from the bottom of the inner container, which bottom has been removed and a well-tinned and perforated one replaced.

The lip on the outer container serves to add boiling water from time to time, after which it is packed with ordinary cotton.



Through the centre of the cover of boiler is an opening, which answers as a receiver for a thermometer whose scale is divided from  $120^{\circ}$  to  $220^{\circ}$  F. A layer of absorbent gauze covering the perforated bottom prevents boiling water to come in direct contact with substance to be sterilized and completes the apparatus. A tripod and frame containing an alcohol lamp with (4) four burners accompanies the sterilizer in the event that a stove or gas or oil burner is objectionable. With eight ounces alcohol a temperature of from  $210^{\circ}$  to  $212^{\circ}$  F. for two hours can be obtained. The above illustration shows the apparatus ready for use.

**Zentmayer's American-Continental Stand.**—This stand has been designed to meet the wants of those workers who prefer the compact Continental model and yet are conscious of its inherent defects. It is substantially a combination of the upper half of our celebrated American stands with the lower half of the best Continental stands, and is adapted to have added all the usual optical accessories of either class of microscopes. As offered, it answers fully every want of the class-room or laboratory at very moderate cost.

The stand is constructed entirely of brass, handsomely finished and polished. The base is of horseshoe form, filled with lead for extra weight, and gives perfect steadiness in every position. A stout pillar firmly supports the arm of the instrument on a trunnion-joint, which allows all inclinations from the perpendicular to the horizontal position. The coarse and fine adjustments are of the same style and construction as the famous Centennial stand. The arm carrying the body is provided with two slides, the upper and longer one bearing the tube with rack and pinion movement, and sliding in the lower one, which is controlled by a lever of the second order, operated by a milled-headed micrometer screw in convenient position at the back of the instrument. At the bottom of the lower slide there is a shoulder against which the lever acts, and a spring above presses down against this shoulder, insuring its continuous contact with the lever during adjustments. All the mechanism is concealed within the arm, which is so hollowed as to secure both lightness and greater rigidity. This fine adjustment is free from lateral motion, and exceedingly sensitive. Its construction prevents wear, and is so positive that a revolving nose-piece and attached objectives can be easily carried without injury. It also acts as a safety appliance in case an objective is accidentally racked down against an object, for the spring yields quickly to upward pressure. The body-tube is five and one-half inches long, with draw-tube extending full ten inches, thus giving both English and Continental standards, and accommodating objectives corrected for either length. The stage is made of aluminum, which is incorrodible; the dimensions (three and five-eighths inches square) are commodious even for culture slides or serial sections; the surface is plane, with recessed opening to receive a glass plate, light modifier, or disk-diaphragm, if wanted; removable clips are provided with springs shaped and adjusted to

hold a slide, and yet allow easy movement about the field of view. The substage has long sliding movements in the fixed bar beneath the stage, allowing ample room for a condenser or polarizer, and exact adjustments are easily and quickly made by aid of milled knobs extending on each side of the sliding bracket, on which the ring of the substage is centered and affixed instantly by means of a single set-screw with capstan head. The mirrors are plane and

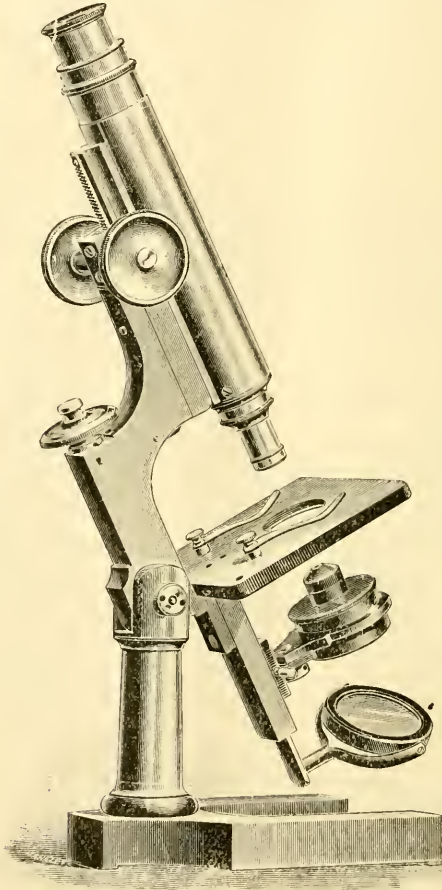

Zentmayer's American-Continental Microscope.

concave, of large size, and have complete adjustments on an extensible bar. The diaphragms are cone-shaped, and have three different sizes of apertures. The Abbe illuminating apparatus has a condenser of 1.20 N. A. and Iris diaphragm with complete movements. A condenser of 1.40 N. A. can be substituted, if preferred, for the difference in the cost of the condensing systems. A set of stops are also furnished for dark-ground illumination.

The stand can be furnished with a swinging substage, with or without rack and pinion movement; and with a circular centering and revolving stage, provided with a sliding carriage similar to the Centennial stand; at an additional moderate expenditure, and it is well worthy of such conveniences.

A modification of the swinging substage and mirrors can also be furnished, whereby the extensible mirror-bar slides in another bar which swings from a joint on the under side of the swinging-bar carrying the substage. The construction allows the substage and mirrors to swing independently of each other, click-stops indicating when either or both bars are in the optic axis of the instrument; and permits the substage to be swung aside entirely and the mirrors alone to be then swung into positions for central or oblique illumination, without interference from the substage. The mirrors can be likewise swung aside completely to permit the use of direct illumination, with or without substage apparatus. These movements contribute much to convenient and rapid use, as it is unnecessary to remove and afterward return the substage, or mirrors, or any other part. In this instance the stage is made somewhat narrower to allow the substage to swing clear aside.

**A Microtome for 50 cents.**—Dr. Hinz has described his instrument in the *Omaha Clinic*. The main body is a tin pot 3 inches high by 8 in diameter. A bridge 2 inches wide crosses the top (or open end of the can) and is soldered to the sides of the pot. In its centre is an opening which is the termination of the well, and around the well opening is a glass ring over which the knife is to glide. The space around the well can be filled with ice for freezing. Connected with the well he has a millet screw four inches long and with 40 threads to the inch. One revolution produces a section 1-40th inch thick; one-half revolution, a section 1-80th inch, etc. An amputating knife or razor can be used to cut the sections.

---

## MICROSCOPICAL MANIPULATION.

**Examination of Cements.**—We are indebted to Mr. Wm. C. Holliday, of Dunkirk, N. Y., for the following abstract of an article published in a recent issue of the *Engineering News and American Railroad Journal*.

On pages 481 and 482 of the *Engineering News and American Railway Journal*, vol. xxvi, No. 47, Nov. 21, 1891, Mr. Alden H. Brown, a student of the Iowa University, gives his observations and conclusions concerning some of the cements used by stone and brick masons in this country.

His conclusions are "that the relative values of any two [or more or any number] cements may be determined by a microscopic examination by observing the following rules:

“1. See which cement has the greatest angular, vitreous particles.

“2. Notice the transparency of the particles.

“3. Notice the amount of foreign matter present.”

His observations are :

I. *Buckeye Cement*.—“As will be noticed, the particles are sharp and clearly defined, and apparently of homogeneous texture; all the particles, whether large or small, have the same general appearance. By a proper manipulation of the microscope it may be shown that the mass has been completely vitrified. The uniformity in the appearance of the particles shows that either there are no foreign substances present or that they are not in sufficient quantity to be visible. Up to the present time this cement has given the best results of any that have been tested in the university laboratory.” (See attached table giving comparative values from crushing briquettes.)

II. *Gibbs' Portland Cement*.—“The general appearance is much the same, and at first sight might be said to be identical except for the difference in the distribution of the particles, which is, of course, purely accidental; but if we look closer we will see that the particles are not quite so clear as in the preceding case, and that there are quite a number of minute rounded particles which are entirely different in appearance from the particles which surround them. These are probably small beads of glass, formed during the burning process, from free silica existing in the clay from which the cement is made. This, as is well known, exerts an injurious effect on the quality of the cement, by introducing an inert foreign substance which interferes with the setting of the cement. The slight opacity of the particles of the cement may be due to the admixture of some foreign substance, or to some fault in the burning.”

III. *The South Bend Cement*.—“This appears to be almost identical with the one last described, except, perhaps, that some of the particles are rather coarse. Both the Gibbs' and South Bend cements have given excellent tests, although not equal to the Buckeye.”

IV. “*Rosendale cement*, which, according to the tests made last year, has the greatest tensile strength of any of the natural cements. As we should expect, it is very different in appearance from any of the artificial cements we have just described. The fact that it has not been completely vitrified will account for the opacity and indistinctness of the particles; still it is quite homogeneous in appearance and is much more vitreous in structure than any of the other natural cements.”

V. *Utica Black Ball*, and VI. *J. Clark's Utica Cements*.—“These are almost identical in appearance, consisting of opaque masses, surrounded by numerous minute glassy particles. Some of these particles are rounded and are probably similar to those we have already noted. There are others, however, with a

sharp, angular outline. These are probably due to the vitrification of some portions of the cement material."

VII. *Milwaukee Cement*.—"There is little, if any, distinctness in the individual particles, which are collected in opaque masses, and the particles, which are collected in opaque masses, and the particles themselves are almost entirely opaque. This cement did not give as good results as the others mentioned."

No preparation is necessary except to sprinkle a little of the dry cement upon the slide—"and examine it with an objective of considerable power."

The article is illustrated with a number of plates, but they cannot show as the slides do. A number of these plates show the cement after it has been mixed with a little water and allowed to set upon the slide. From this no special preparation is necessary.

Natural cements are those "in which the burning process has not been carried to the point of vitrification, while Portland cements are those which have been vitrified by burning."

Below is given a table showing the pounds per square inch required to crush briquettes made from the cements, as reported by Mr. M. I. Powers, another student of the same university :

Order given by Mr. Powers.		Order given by Mr. Brown.	
Buckeye, Portland.....	Artificial Cement... Bellefontaine, Ohio... 650	pounds... Buckeye.	
Gibbs' Portland.....	" " ... Grays Essex, Eng.... 350	" " ... Gibbs'.	
South Bend.....	" " ... South Bend, Ind.....		
Hoffman's Rosendale... Natural Cement...	Kingston, N. Y..... 310	" " ... South Bend.	
Utica Black Ball.....	" " ... La Salle, Ill..... 280	" " ... Rosendale.	
Milwaukee.....	" " ... Milwaukee, Wis..... 120	" " ... Utica Black Ball.	
J. Clark's Utica.....	" " ... Utica, Ill..... 70	" " ... Milwaukee.	

Although the table is not quite complete, it is easily seen that the order of strength, as found by crushing briquettes, is nearly the same as the order of quality determined by the microscope. The only marked difference is between the Milwaukee and the J. Clark's Utica cements. Possibly the specimen of cement used by Mr. Brown was not up to the same standard of quality as that used by Mr. Powers.

DUNKIRK, N. Y., July 12, 1892.

**Mounting Trichinæ.**—With your permission I would like to suggest to Messrs. Whelpley and Farr (queries 32 and 43, June number) a method for mounting trichinous muscle which I have found very successful. Macerate a small piece of the muscle in cold water for a day, now tease it out with needles and place between two slides and bind with stout thread; immerse in alcohol about 95% for about *ten* minutes, then separate slides and transfer muscle to oil of lajeput; let it stand here for two or three days and mount in balsam, when they will find the trichinæ will not "disappear," nor will they shrink as I have had them do in time after having used the alcohol solution for a longer time.

W. N. PRESTON.

**Gum for Slide Labels.**—Dissolve 2 grams of aluminum sulphate in 20 of water. Mix the solution with 250 grams of strong mucilage (2 of acacia gum to 5 of water). The aluminum sulphate greatly increases the adherent properties of the gum.

## CORRESPONDENCE.

*Editor American Monthly Microscopical Journal:*

Allow me to warn your readers that the slide-box figured and described in July JOURNAL, p. 166, invented by Mr. Mosely, will prove a delusion and a snare to whoever tries to use it. I devised and made that precise thing over twelve years ago and discarded it in disgust after some months of use. The box is indeed *compact*, but has the important disadvantage of great liability to *spill the slides*. One who tries it will be surprised to find how slight an inclination will cause the slides to slip from their compartments. If the box be held open in one hand while the owner turns to look for something, or stoops to pick something up, it will be a common experience to find a number of slides tumbling about his feet. Even on a table a casual jar will start the slides, and while I had mine in use I several times had a number of the slides spilled out by the quick turning of a revolving table on which the open box was placed. About the same time I made a box with fixed compartment shelves, with the shelves stepped so as to show all the labels, but this was finally discarded for the same reason as the other. Then I made a box of the common Piper pattern and arranged the trays to slide out in steps, like the Mosely shelves; this was easily done by fixing a pin in the top and a groove in the bottom of each tray, but was not practicable with a box of more than six trays, unless the trays be adjusted in series of six each, and as six of the Piper trays can be readily lifted at one edge by the thumb enough to let the slides in each tray be seen, seriatim, without taking the trays from the box, this too was abandoned as useless. If any one cares, however, to make the sliding tray-box, I will send him the drawings which I made to work from when I made mine. C. M. VORCE.

## MICROSCOPICAL SOCIETIES.

LINCOLN MICROSCOPE CLUB, LINCOLN, NEBR.—ROSCOE I. POUND, *Secretary*.

The Lincoln Microscope Club was founded December 31, 1891, and now has a membership of thirty, not including honorary and non-resident members. Among the active members are Dr. C. E. Bessey and Prof. Laurence Bruner, of the University of Nebraska. Prof. Leighton, the well-known microscopist of Omaha, and Dr. F. S. Billings, of the University Patho-Biological laboratory, are among the honorary members.

Meetings are held the last Tuesday evening in each month. The club has the use of one of the botanical laboratories in Nebraska Hall at the University, and has put in the proper lamps and fixtures so that a large number of instruments may be used at night. The club has the use of the microscopes and accessories of the Department of Botany and has access to the library of the department, which contains the principle microscopical magazines. The members usually bring their instruments with them to the meetings and exhibit slides and other objects of interest at the close of the meetings.

*June 28.*—Dr. Billings gave a lecture on Bacteriology, and at its conclusion, in answer to questions, spoke on methods of making permanent mounts of bacteria and of decolorizing animal tissues in sections. Mr. Webber, of St. Louis, gave some observations on the structure of the capsule in *Yucca*, and, answering questions, suggested a new manner of fixing celloidin sections. Among the slides exhibited were several by A. F. Woods illustrating some new methods with glycerine jelly.

#### NYACK ASSOCIATION, NYACK, N. Y.

The society has just entered upon its second year with growing interest in its pleasant and instructive work. Its new officers are: President, Dr. G. F. Blauvelt; Vice-President, Mr. F. G. Provost; Recording Secretary, Miss Whittaker; Corresponding Secretary, J. C. Gregory; Treasurer, A. M. Voorhis; Curator, Prof. I. Lawton. Meetings are held on the first Wednesday evening of each month.

The work done by this society is educational as well as interesting, and affords the members many hours of research and recreation.

*May 6, 1892.*—The annual exhibition was given at the residence of J. C. Gregory. Eleven microscopes were used in the exhibition. These were arranged on tables scattered through several rooms, occasioning frequent tours from one to another to witness the changes of the subjects. While all were of interest, perhaps the most fascinating was an exhibition of the circulation of blood in a live frog's foot, given by Dr. G. F. Blauvelt, who gave a number of exhibitions in the line of histology.

Mr. Gregory exhibited some mineral crystals, shown by reflected light, and Miss Gregory's line was vegetable sections exhibited by polarized light. Mr. F. G. Provost's selections for the evening were botanical, and Mrs. Provost's were entomological, shown with condensed light. Prof. I. Lawton showed some interesting specimens in entomology. Dr. Coltrin embraced entomological and botanical subjects in his list of exhibits, shown by transmitted light. Miss Whittaker's line of exhibits was botany and entomology; Miss Stillwell's was entomology, and Miss Partridge's was the same. Edgar E. Blauvelt gave, among other things, an interesting exhibition of animalculæ in water obtained

from a small pond in Tillou's woods. Dr. Meeker interested many with specimens in crystallography, showing specimens of chemical salts under polarized light.

### NOTICES OF BOOKS.

---

*Die Botanische Mikrotechnik.* By Dr. A. Zimmermann. Tübingen, 1892, pp. 278.

This is a handbook of microscopical technique especially as related to botanical work. It is illustrated with 63 engravings in the text and accompanied by a copious bibliography and index. Being in German it is not available to American workers in general, but some of our advanced manipulators who read German will find it useful. The price is 6 marks. Order it from H. Laupp'schen Buchhandlung in Tübingen or from F. A. Brockhaus in Leipzig.

*The Supreme Passions of Man: or, the Origin, Causes, and Tendencies of the Passions of the Flesh.* By Paul Paquin, M. D. The Little Blue Book Co., Battle Creek, Mich. 12 mo, square, pp. 150.

Several years ago, while making comparative tests of culture media for the nutrition of micro-organisms in the laboratory at the University of Missouri, Dr. Paquin became deeply interested in the striking differences which different food substances or culture media produced in a given organism. He found himself capable (as many others have done, doubtless) of altering the shape, size, energies, color, properties, in fact, all the vital attributes, it seemed, merely by varying the kind, quality, and quantity of food material. This phenomenon opened a new line of thought. If we can alter the unicellular beings so much merely by the food supply, why not alter likewise the cells of multicellular bodies, and modify their attributes? He first tried to find the explanation of certain physical defects and obscure organic diseases. From this he came to seek an explanation of the impulses of passions, and to set forth the results of inquiries into the appetites of mankind and the passions which they excite. The book includes a study of the crimes of the flesh and the efforts of christianity to maintain purity; an essay on the true causes of drunkenness and the only way to prevent this evil; observations on the relation of vice to the laws of nations and existing educational systems.



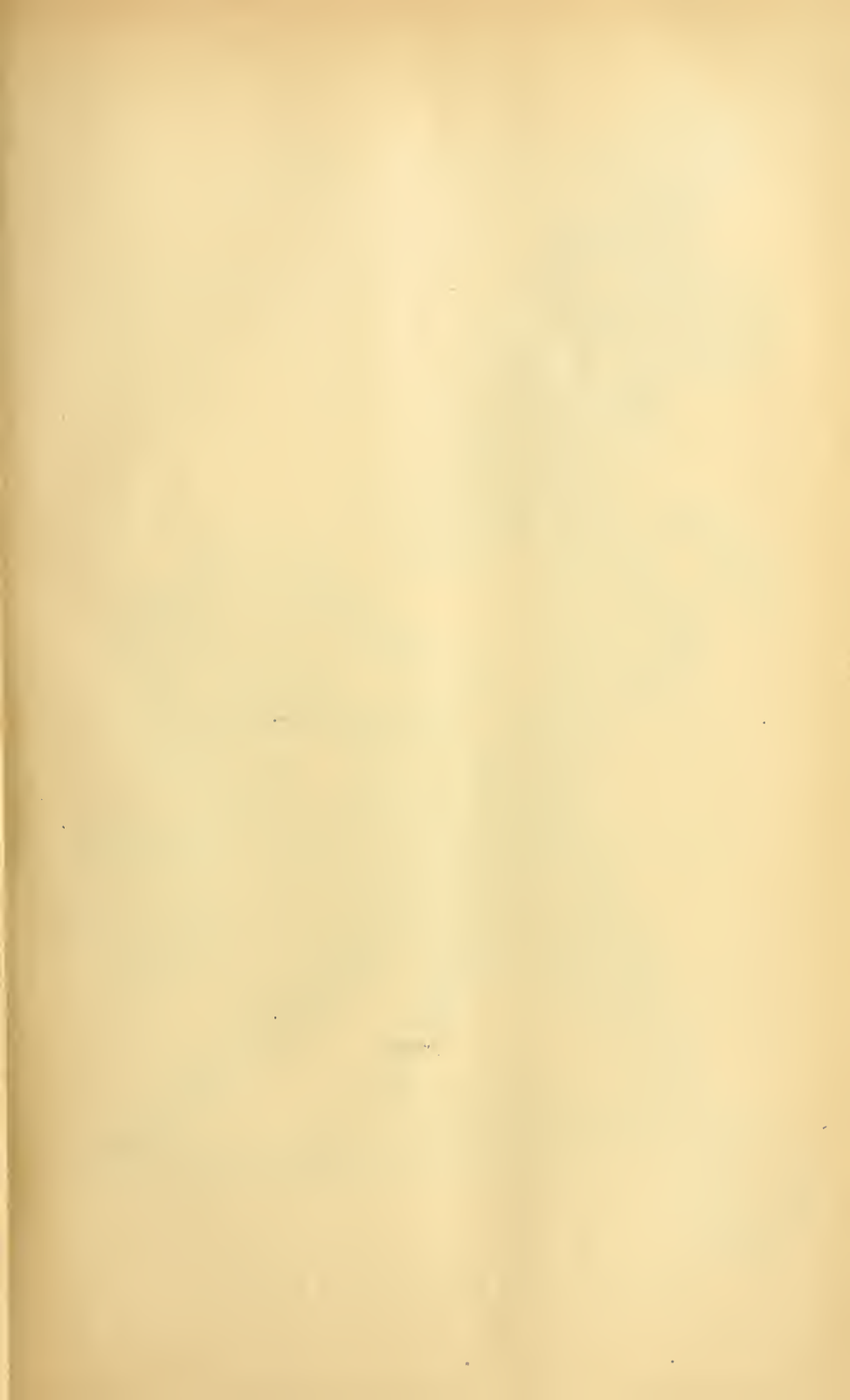

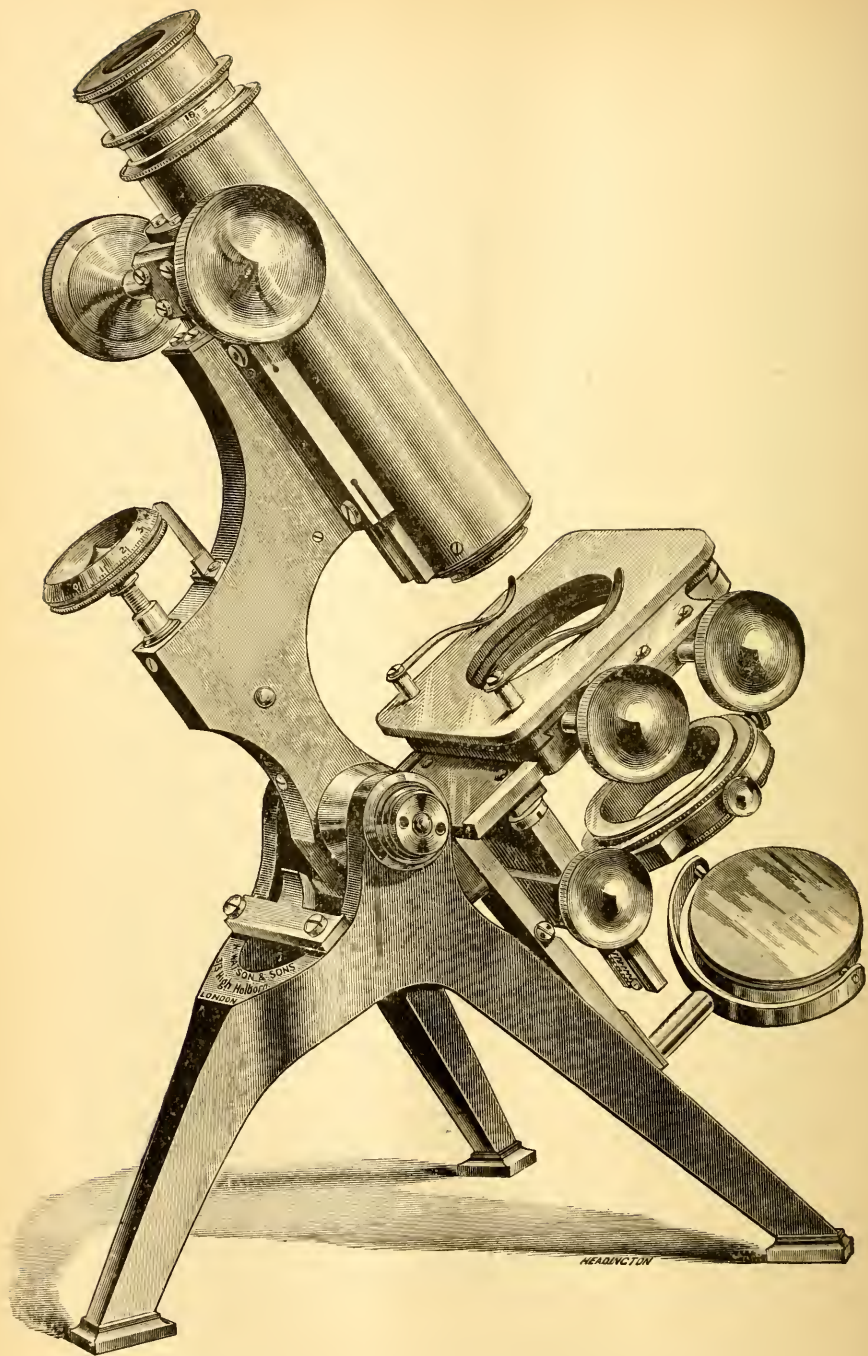

THE TRIPOD EDINBURGH STUDENT'S MICROSCOPE.

# THE AMERICAN

## MONTHLY

# MICROSCOPICAL JOURNAL.

VOL. XIII.

**SEPTEMBER, 1892.**

No. 9.

### CONTENTS.

<p>The Fifteenth Annual Meeting of the American Microscopical Society.—SMILEY - - - 201</p> <p>The Leeuwenhoek Microscopical Club of Manchester, Eng.—SMILEY - - - - - 210</p> <p>What is a Species in the Diatomaceæ.—EDWARDS - - - - 212</p> <p>Radiolaria: Their Life-History and Their Classification.—CARTER - - - - - 216</p>	<p>MICROSCOPICAL APPARATUS.— Edinburgh Student's Microscope (illustrated) - - - - 219</p> <p>MICROSCOPICAL NEWS.—The Microscopic Determination of Rock-forming Minerals - - 220</p> <p>MICROSCOPICAL SOCIETIES.— San Francisco. London - - 221</p> <p>NEW PUBLICATIONS.—Murtfeldt. Wood. Stephens - - - - 223</p>
-------------------------------------------------------------------------------------------------------------------------------------------------------------------------------------------------------------------------------------------------------------------------------------------------------------------------------------	-------------------------------------------------------------------------------------------------------------------------------------------------------------------------------------------------------------------------------------------------------------------------------------------------------------------------------

## The Fifteenth Annual Meeting of the American Microscopical Society.

BY ROBERT W. SMILEY,  
WASHINGTON, D. C.

The American Microscopical Society, formerly the American Society of Microscopists, held its fifteenth annual convention in the city of Rochester, N. Y., August 9 to 12, inclusive. The meetings were opened to the public and enough popular interest was manifested to insure a goodly attendance.

The opening meeting was held in Anderson Hall, on the University campus.

The morning and afternoon sessions of the society were given up to business and reading of papers, while the evenings were devoted to the reading of the presidential address and various social gatherings.

The Delta Upsilon chapter house, at the corner of University avenue and Goodman street, was the headquarters of the society,

and with two exceptions its meetings were held at Anderson Hall. The first exception was Wednesday evening, when the president delivered an address at Music Hall, and the second the grand microscopical soiree at the Arsenal Thursday evening.

#### TUESDAY MORNING.

Prof. Lattimore, of Rochester, welcomed the visiting society in a most cordial address. He referred to the visit the society had made to Rochester in 1884, and then said: "The university says to your association what the Spaniard tells his guest—'This house is yours!' We wish to thank your society for the influence which it exerts on our city."

President M. D. Ewell, of Chicago, responded to this friendly greeting with thanks, and expressed the wish that there might be a full discussion of all papers.

The following were then elected members of the society: A. W. Montfort, Burlington, Iowa; E. E. Glover, Terre Haute, Indiana; Professor E. R. Boyer, Chicago; Henry Leflman, Philadelphia; Dr. E. K. Dunham, New York; H. F. Sedgwick, Nashville; E. M. Mitting, Chicago; C. H. Gordon, Cook county, Ill.; E. L. Sherwood, Houston, Miss.; E. S. Mattison, Pottes county, Pa.; O. C. Fox, Washington; George Rust, Denver; C. S. Bower, Philadelphia; G. W. James, Chicago; Alfred Lasche, Chicago; Dr. W. E. Everette, Tacoma, Wash.; W. N. Preston, Chicago; C. O. Smith, Portland, Me.; Miss L. S. Brown, Angelina, N. Y.; J. E. Bull, New York; B. W. Griffith, Los Angeles; Clark Bell, New York

President Ewell, of the committee on the World's Fair, reported that the Fair people wanted to hold a microscopical convention or congress in May, but as a large number of the members of the society were teachers he did not think such a date would be a good one. The society referred the matter to the executive committee.

Secretary Seaman started an interesting discussion on the matter of a standard microscopic screw. Upon this question Mr. Edward Bausch spoke of the recent discussion of the matter in Germany, and the difficulties in the way of the adoption of a standard. "The broad gauge screw," said he, "is undoubtedly a thing of the past. The tendency of manufacturers, which, of course, reflects the tendency of popular opinion, is to reduce lengths and size. With the smaller instruments now manufactured it is safe to say there will be no enlargement of the screw."

Four sections of a new constitution were adopted, and the remainder of the session was occupied with similar routine business. As many of the most prominent members of the society were expected to arrive in the afternoon, it was resolved to adjourn until evening.

An invitation was received from the Bausch & Lomb Optical Company to take electric cars, to be provided for the visitors, and

inspect the company's works. The matter was referred to the local committee.

#### TUESDAY EVENING.

The evening session was devoted to the reading of the presidential address. In spite of the extreme heat and the technical nature of the subject there was a fair attendance at Music Hall. The subject was "The Relation of the Microscope to the Administration of Justice."

We hope to publish Prof. Ewell's address in full in an early number of the *Journal*.

#### WEDNESDAY MORNING.

The following committee on nominations was suggested: Mr. Hyath, Professor Gage, Professor Miller, Professor Kellicott, E. Bausch, Dr. Deck, Professor Krauss. Mr. Miller withdrew his name and the other seven were elected.

The first paper of the day was then read by Prof. Gage, on "Methods of Decalcification in which the Structural Elements are Preserved." Prof. Gage gave a practical illustration of this method, using part of the rib of a cat. Among other things, he said:

"Bone used to be studied in sections, as rock now is, but the living part of the bone is far more important than the dead structure. How, then, can we get rid of the bony part and save the live protoplasmic elements? It is a fatal blunder to put bone while fresh into the decalcifying substance, for thus the live parts are ruined. It should be treated more as a muscle or piece of tissue. I advocate hardening the whole bone in picric alcohol, as for muscle, and then putting in 67 per cent. of alcohol with 3 per cent. of nitric acid. Thus the alcohol restrains the decalcifying action of the nitric acid. The bone is never scraped, and is put in collodium."

Mrs. Gage gave an account of a method she had employed for putting together sections of a whole where microscopic study had to be done in sections. Her suggestion was a modification of the card catalogue system used in libraries. She exhibited a series of magnified sections upon cardboard arranged upon her plan.

Dr. W. C. Krauss read a paper on the diagnosis of tumors.

New members were elected as follows: Adolph Lomb, Rochester; S. A. Ellis, Rochester; Dr. T. Eugene Oertel, Washington; E. F. Bigelow, Portland, Conn.; Charles U. Amelie, Rochester, Minn.; Professor Bentley, Chicago, Ill.

The remainder of the session was occupied by a discussion of plans for a working session at the meeting at the World's Fair next summer.

#### WEDNESDAY AFTERNOON.

The society met at 2 o'clock in Sibley Hall and listened to a very interesting lecture by Rev. D. W. Smith on "Recent Re-

sults in Photomicrography by Improved Substage Illumination." The lecture was illustrated with work done by the author.

Dr. George M. Sternberg, U. S. A., gave a very entertaining discourse on "Photomicrographs by gas-light," illustrated with lantern views.

At 4 o'clock the microscopists enjoyed an excursion to Lake Ontario. Supper was taken at the Hotel Ontario and speech-making was the order of the day.

#### THURSDAY MORNING.

The microscopists were on hand promptly at the business meeting this morning, but much time was occupied in adopting a new constitution section by section.

When this was finished Professor Clark Bell, of New York city, read a paper on "Blood and Blood Stains." Red corpuscles were first discovered in human blood in 1673. Oval and nucleated corpuscles were found in birds and fishes, reptiles, etc., but not in mammals.

Professor William A. Rogers, of Colby University, Waterville, Me., read a paper on "The Filar Micrometer." Professor Rogers stated that in his work of investigating standards of length he required a Filar micrometer of superior construction. Failing to find such an instrument in the market, he asked Bausch & Lomb, the well-known optical firm, to make one which would fulfil the required conditions. After many trials the instrument was completed to his entire satisfaction. The instrument in question is an eye-piece in which there is a fine spider web moved by means of a precision screw. The difficulty in ordinary micrometers consists in the lack of delicacy of movement of the springs which press the micrometer plate against the end of the screw. This difficulty Bausch & Lomb have averted.

Professor Rogers read a second paper, on the "Use of the Microscope in the Workshop." The speaker stated that he had for some years advocated a more extensive use of the microscope in the ordinary operations of mechanical construction. His paper was an enumeration of the different mechanical operations in which he found the use of the microscope profitable. Among those specified were:

First, to divide an index wheel in 1,000 equal parts; second, in setting the ways of a large planer horizontal; third, to ascertain whether a piece of planed work has its surface truly planed before the piece is taken from the planer; fourth, to ascertain whether the planer planed a piece of metal in a straight line; fifth, to plane two surfaces exactly alike; sixth, to set the line between the centres of a lathe parallel with the ways; seventh, to test the turning of a true cylinder; eighth, to test the accuracy of the screw of a common lathe.

As an illustration of the last point, the speaker described his test of a precision screw twenty-one feet in length, made by Pratt

& Whitney, of Hartford, for the R. Hoe & Co. printing-press manufacturers. This screw, considering its great length, was found to be of exceptional accuracy.

#### THURSDAY AFTERNOON.

Professor E. H. Griffith, of Rochester, N. Y., read several papers in the afternoon descriptive of a new microscope and of new microscopical accessories. The instrument is the invention of Mr. Griffith himself and is manufactured by the Gundlach Optical Company. The principal features of the improvements are its portability, packing as it does in small cases, and a centering, swinging, and removable substage. The Griffith microscope lock, a device which can be attached to any microscope, was also described. It securely locks the adjustments and prevents accidents to objectives and slides. Mr. Griffith also gave an account of another improvement recently devised by him and put into practical use. This is a cover-glass micrometer to be attached to the turn-table. He also has a new substage diaphragm. The use of the latter is to regulate the intensity of the light.

Frank Zentmayer read a paper describing a microscopic stand recently invented by him for the University of Pennsylvania. It is intended to be a combination of the best features of the American and Continental microscopes. One of the new features, and an American feature at that, is an aluminum stage. This is the first time aluminum has been employed by microscope manufacturers, and Mr. Zentmayer expressed the opinion that the use of aluminum would soon be more extended, as the metal does not corrode by contact with acids, which the microscopist is often called upon to examine.

Other papers were presented at to-day's meeting by Professor Kellicott, Dr. Munn, G. W. Rafter, Dr. Mercer, and M. L. Holbrook.

Later in the afternoon the members and friends took cars at the university for the Bausch & Lomb Optical Company's factory, where the remainder of the afternoon was utilized in an inspection of the works.

#### THURSDAY EVENING—THE SOIREE.

As at all previous meetings, the soiree was the notable feature of the assembly of microscopists. At 8 o'clock the microscopes were all in place and the exhibit was in full progress.

Most of the objects exhibited were of a popular nature rather than of the most particular scientific interest. Among them were exquisite histological specimens, diatoms, metals, disease growths, tissues, forms of vegetable and animal life, bacteria, trichinæ, gold, hairs, teeth, crystal, &c.

A few of the more important exhibits were as follows:

By Dr. F. D. Andrew, Rochester.—Human lung; and growing bone.

By E. H. Bacon, Rochester.—Black walnut; and fresh-water sponge.

By Bausch & Lomb and the Gundlach Optical Company an exhibit of a large number of microscopes with various objectives.

By Miss Florence Beckwith—Specimens from the vegetable kingdom.

By Professor W. G. Crosby, Canandaigua—Anchors and plates of *Synapta agasezii*. picules of gorgonia, teeth of ear shell, "Queen" golden rod, disks of water beetle, necklace algæ.

By Dr. Lyman Deck, Salamanca—Nose of field mouse.

By A. M. Dumond, Rochester—Skimmings from Irondequoit Bay.

By H. H. Doubleday, Washington—Etalcedony and young oyster.

By Dr. Charles Forbes, Rochester—Apparatus for photomicrography, designed by the exhibitor.

By Dr. S. O. Gleason, Elmira—Brazilian beetle and native copper.

By Dr. George W. Goler, Rochester—Normal histological specimens.

By J. B. Holman, Rochester—Body louse.

By H. W. Hoyt, Rochester—Human kidney, hypertrophied tonsil, sarcoma.

By Dr. Lucien Howe, Buffalo—Blood vessel of eye; eye of insect.

By W. L. E. Haag, Toledo—Foot of spider; sting and poison sac of wasp.

By Professor J. W. Hyatt, New York—Agate and glass sponge, crustacean parasites from miller's-thumb, and mite from gland of pigeon.

By Joseph L. Levi—Eggs from parasite of horse, ovary of fish, sections of very young chicken, common earth worm.

By William H. Lothridge, Rochester—Flea; pollen of lily.

By Miss M. E. McCauley, Rochester—Star-shaped cells of *Nuphar advena*.

By Dr. C. G. Mitchell, Canandaigua—Teeth of snail; golden-eyed house-fly.

By Robert Moody, New Haven—Twins in single-yolk egg; sections of bone.

By Dr. C. C. Mellor, Pittsburg—Foraminifera; diatoms.

By Mrs. J. H. McGuire, Rochester—Section of yellow pond lily.

By E. Ocumpaugh, Rochester—Claws of spider; foot of horse-fly.

By R. A. Punnett, Rochester—Fly's foot; proboscis of butterfly.

By Dr. Anna H. Searing, Rochester—Cluster cups of fungus of farberry; stillate hairs from leaf.

By Dr. H. W. Streeter, Rochester—Cyclosis in *vollimeria*; circulation in eel grass.



By Mrs. William Streeter—Marine diatoms; pollen on foot of bee.

By Dr. W. H. Seaman, Washington—Male and female firefly and their luminous gland.

By Miss Sarah F. Whiting, Wellsley, Mass.—Insect scales; salt crystals.

The exhibit lasted two hours, and the wonders of the microscope seemed veritable miracles to some, who for the first time peered through the tube. There were at least a hundred microscopes, and every one of them was besieged by a line of eagerly curious men and women.

In one of the microscopes shown by Professor Griffith was a bouquet of flowers. It was made of the scales of the butterfly arranged with the most wonderful artistic skill in a space no bigger than a pinhead. Another microscope revealed the Lord's prayer through a pinhole. The exhibit which attracted the largest share of attention and which, perhaps, was the most instructive was a series of nine microscopic objectives interspersed with drawings showing the growth of the starfish at all stages. This exhibit was prepared by Professor Charles Wright Dodge and it was besieged all the evening by throngs of spectators. You had to "get in line" and gradually work your way along.

Another exhibition which attracted much attention was the circulation of blood in the tail of a fish, shown by William Drescher. This was accomplished in a most ingenious way. A living gold fish was securely fastened in a small vessel containing just enough water to keep it alive. Its tail was projected over the side of the vessel, pressed between two small pieces of glass and firmly fixed under the microscope. The power of the microscope was so high that it resolved the blood, seen through the transparent covering of the fish's tail, into countless little corpuscles, which gave it the appearance of multitudinous grains of sand following each other in and out and round about in endless procession up one aisle and down another, constantly twisting and turning. An extra gold fish lay in a pail of water by the side of the microscope so that the fish on duty might be relieved should he give signs of failing vitality. Mr. Drescher stated that a fish would ordinarily accommodate the investigator in this way for an hour or an hour and half. At the other end of the room was exhibited a frog's foot in similar fashion.

Professor Seaman, the secretary of the society, to whose energy much of its vitality is due, exhibited a firefly under his lens. He has made a special study of phosphorescent light in organisms and says that the number of such insects is much larger than is generally supposed and that the firefly is by no means alone in his glory.

Professor Rogers, the microscopic mathematician, exhibited one twenty-fifth of an inch ruled off into 100 equal parts—a subdivision of the inch into 2,500 equal parts. Professor Rogers

does this work with a machine of his own invention, cutting his lines upon gold with a diamond. He uses gold because it is more easily reducible to a finely polished surface.

Professor Claypole exhibited the gizzard of a black beetle and the eye of a crayfish, which were shown by his twin daughters, who are both accomplished microscopists.

Sarah F. Whiting exhibited the eye of a beetle in which a little cross marked on the glass beneath it was reflected 1,000 times. It would be difficult to catch the literally Argus-eyed beetle asleep.

Many other equally interesting specimens were on exhibit, but space will not permit a more extended notice. The soiree was a great success.

#### FRIDAY MORNING.

The microscopists held their concluding session this morning. Professors Kellicott, Rogers, and Claypole were appointed a committee to consider the question of changing the time of meeting so that it should hereafter more closely precede that of the American Association for the Advancement of Science. Mr. C. C. Mellor, of Pittsburg, read the treasurer's report, showing expenses \$866.58 and a cash balance of \$178.17. The society accepted with thanks the anonymous offer of these prizes to be awarded at the next meeting: For the best original investigation of plant life, first prize \$50, second \$25; for the best original investigation of animal life, first prize \$50, second \$25; for the best mounted slides, first prize \$20, second \$10; for the best photomicrographs, first prize \$20, second \$10. Professors Kellicott, Gage, and Seaman are to announce the conditions in the next number of the society's official publication, and the executive committee of the society is to make the awards.

Professor E. W. Claypole chose a popular subject and spoke with great emphasis on the general introduction of cheap microscopes. The paper pointed out the importance for the diffusion of a knowledge of microscopic science of a low-priced grade of compound microscope suitable for students of high schools and college graduates. They can seldom afford the cost of even the cheaper instruments in the market, and consequently drop in most cases their studies in this direction on leaving school or college. Most of the machinery and some of the adjustments might be dispensed with and the cost thus reduced. It is not likely that by any means the cost of such an instrument could be brought down to the level of the school microscopes, which have been in use in England for nearly forty years, but considerable reduction could be made by the changes suggested. Good instruments of the nature above outlined are sold and have been sold for about \$15 in England, and are abundantly sufficient for the needs of the average microscopical student. Moreover the ownership of a microscope is essential for the continuation of the study, and the purchase of

even an inferior instrument often leads to the purchase of a better one in later life. This reform may be expected to swell the number of that part of the community from which the ranks of the microscopical society are recruited.

By way of illustrating his remarks, Professor Claypole exhibited a microscope which had been sold in England forty years ago for \$15. He wished that something could be done here to put a cheap microscope within the reach of students. This brought forth considerable discussion. One wanted to know what were the wages of the men employed to make that instrument. Another called it a toy for a child, a third thought it a pretty poor piece of work. Professor Rogers and Dr. Ewell spoke in favor of a cheap microscope of American make for class-room work, urging that a poor microscope in the hands of a student after leaving college was better than no microscope at all.

The nominating committee reported the following officers and the report was adopted by their election: President, General Jacob D. Cox, Cincinnati; First Vice-President, Dr. George M. Sternberg, Brooklyn; Second Vice-President, Dr. A. Clifford Mercer, Syracuse; Secretary for three years, Dr. W. H. Seaman, Washington; Treasurer for three years, Charles C. Mellor, Pittsburg; Executive Committee, Dr. Lester Curtis, Chicago; Dr. J. M. Lamb, Washington; Dr. William C. Krauss, Buffalo.

The convention adjourned to meet in Chicago next summer, but most of the microscopists remained over in Rochester to attend the meetings of the Association for the Advancement of Science.

Fine exhibits of microscopes, objectives, accessories, microtomes, mounting instruments and materials, lenses of all descriptions, cabinets for slides, microscopical literature, and mounted objects were made by many well-known dealers in microscopic supplies.

The following papers were presented to the committee, but several, owing to the heat and absence of authors, were read by titles only.

By Prof. D. S. Kellicott: "A Crustaceous Parasite of the 'Miller's-Thumb.'"

By Dr. R. G. Nunn, "Scavengers of the blood."

By Mr. G. W. Rafter, "Microscopical Examination of Potable Water."

By Dr. A. Clifford Mercer, "Photomicrographs and Photomicrographical Apparatus."

By Prof. M. D. Ewell, "The Concave Mirror," "The Microscopic Identification of Ink—A Metrical Examination of 1,000 Signatures of the Same Person."

By Dr. M. L. Holbrook, "Structure of Red Blood Corpuscles in Man."

By Mr. Clark Bell, "Blood and Blood Stains."

By Dr. Thos. D. Briscoe, "The Wenham Binocular—can it be made adjustable to a variable tube length?"

By W. N. Preston, "On a New Mounting Table, and a Practical Drying Oven?"

By James H. Logan, "Precious Stones as Microscopic Objectives."

The society met in Rochester eight years ago, and though its growth has been very large since then, a large proportion of the delegates seem to have pleasant recollections of their former visit.

The meeting was an unqualified success and it is to be hoped that the sixteenth annual meeting, which is to be held at Chicago in August, 1893, will prove to be an attraction for a still larger number of the devotees of the science of microscopy.

### The Leeuwenhoek Microscopical Club of Manchester, Eng.

By CHAS. W. SMILEY,

WASHINGTON, D. C.

This club seems worthy of a brief description and perhaps of some imitation in its leading features.

It was organized in 1867 by seven men, six of whom were also members of the Manchester Scientific Students' Association. The Club has always limited its membership to seven—the number that could be conveniently accommodated at each other's houses and seated round a common table, though often a guest or two have been present. Its composition has always been a matter of great care, and its members have been selected from a wide field of possible candidates with the view to representing as many sciences as possible in the pursuit of which the microscope is a necessary instrument. Few papers on technique have been presented, and the Club proudly declares that it never has listened to a paper on the resolution of dots in *Pleurosigma*. Zoology, Botany, Geology, Physics, Chemistry, and Medicine have each been represented in the Club. When a vacancy in membership has occurred through the death or removal of a member the place has been filled with the idea in view of giving variety to the subjects to be presented at its meetings. The inability of the Club to take all comers led to the organization of the Manchester Microscopical Society, of which four members of the Club have been president. Very few changes in membership have occurred, so that in 25 years only 15 different persons have been members, and two of the original members are still in it. It goes without saying that all the members have been microscopists and scientists of standing, or they would not be so prolific as to meet each other's wants for a long term of years. Meetings are held on the 2d and 4th Thursdays of the winter months, the member at whose house they meet being responsible for the program. The topics were at first understood to alternate between practical microscopy (mounting,

sectionizing, etc.) and natural history (results of microscopical work). Slides were always presented illustrative of papers and in sufficient duplication so that each member might take home one for his collection. Rare mementos of departed members, and valuable slides have thus been acquired by all. A form of label was early adopted which has been adhered to ever since.

When the Club was formed glass slips and covers could be obtained only with difficulty and much expense. The worker had often to prepare his own slips, covers, mounting media and cells. Deep cells were rare and cost 5 shillings per dozen. A member of the Club invented the use of button rings for the purpose. Members also introduced an imbedding mass, benzole as a solvent for balsam, a microtome, the iris diaphragm, and several other articles.

The following summary of papers read is of interest: In Practical Microscopy, 15; in Botany, 59; in Zoology, 32; in Entomology, 23; in Geology, 15; in Histology, 10; in Medical Microscopy, 7, and in Crystallography, 3. The number of papers contributed by different members was as follows: 31, 26, 24, 14, 13, 11, 9, 8, 7, 6, 6, 5, 4; total 164. The two founders, who still remain in the Club, have together contributed 55 papers in the 25 years. Most of the papers have been published in the *Northern Microscopist* or in some other suitable medium.

The present name of Leeuwenhoek was not adopted until 1875 and after a brief lapse of a few months in the meetings. Leeuwenhoek's occupation seems to have been a question of historical dispute, but recent research has established that he was beadle to the town of Delft at a salary of 10 shillings per week. He served from about 1660 to 1723, when he died. His duties were not very different from those of a janitor, though perhaps considered more honorable. He lived to be 91 years of age.

MANCHESTER, July 27, 1892.

—O—

I had decided to take but one of them, but since I find that the *Microscope* is to be for amateurs and the *Journal* for advanced workers, I want them both.—*L. A. Willson.*

**Carbol-methylen-blue Method.**—Herr F. Pregl advises the following modification of Kühne's methylen-blue method as it is shorter and less decolorizing than the original procedure. The sections stuck on slide or cover-glass are stained for  $\frac{1}{2}$  to 1 minute with carbol-methylen-blue, with or without aid of heat. They are then washed for a short while with distilled water. Next they are immersed in 50 per cent. alcohol until they become pale blue with a somewhat greenish tinge; after this they are dehydrated in absolute alcohol, cleared up in xylol and imbedded in balsam.—*Journal Royal Micr. Society, Aug. '92.*

### What is a Species in the Diatomaceæ ?

ARTHUR M. EDWARDS, M. D.,

NEWARK, N. J.

A species is evanescent ; that is, it changes with its surroundings, and what we call a species now is not the same that we called a species in times past, nor as it will be in the future. What in Germany is called a species is not the same in England, nor in America is it known by that name. In fact, a species does not exist in the Diatomaceæ any more than, we acknowledge with Dr. W. B. Carpenter, it does in the Foraminifera. These thoughts were brought up by studying the Diatomaceæ. And to study of the Diatomaceæ they must be collected from everywhere, from Halifax, New York, Key West, Bahia, Montevideo, Callao, San Francisco, Sitka, Japan, China, Calcutta, Africa, England and intermediate places, and studied at all seasons, in the summer as in the winter and, above all, living and under various circumstances.

In my memorandum book, wherein I write down at the time and illustrate with colored figures observations made, I find under March 26, 1868, a record of this kind: "I have to-day seen that which, although I was somewhat prepared for it, astonished me. I have for some time suspected that the various *Schizonemas* and *Homæocladias* are but forms of two species. Last Sunday morning (22nd) I collected on the shore at Staten Island, on rocks and stones near the quarantine landing, a mass of matter, mostly Diatoms, as *Mel. nummuloides*, etc. In it is *Schizonema Grevilleii*, and apparently a small form like a small *Schizonema* with parallel sides to the frustule. I mounted some of the mass in glycerine-gelatine, and I see both the large *Schizonema Grevilleii* and the small forms in the same tubes. Since the above, I made other gatherings (March 29 and April 5 and 12) at the same place and found the *Schizonema* which I have called *Grevilleii* and a small *Homæocladia* in the same tubes ; the *Schizonema* is the commonest. Since then (April 21) I have made gatherings at Hell Gate, foot of 58th street, and find the rocks covered with *Schizonema cruciger* and a small form, both in the same tube and both very active. When freed by force from the tube they are both active. Also the large *Schizonema* as at Staten Island with the small form with it in the same tube. I also find, but rarer, *Schizonema Grevilleii* and *S. cruciger* in the same tube." August 13, 1869, there is a memorandum that "in a gathering I made in the 'Mill Pond,' S. W. near the R. R. station, Salem, Mass., last May, I find *Schizonema cruciger* and *Nitzschia closterium* both together in the same tube." April, 1887, is a memorandum that "on an oyster scow at Oakland, California, there is *Schizonema Grevilleii* and a *Homæocladia* both in the same tube."

Now I have to record that for the last two years I have been

enabled to collect in the Passaic river, about a mile from my house in Newark, N. J., *Homæocladia filiformis*, *Schizouema fatida* (*divergens*), and *Bacillaria paradoxa* in plenty at all seasons, except when frozen over. But then I had them living in the house, unfrozen, in salt, brackish, and fresh water. *Bacillaria paradoxa* I had collected in East Newark (now called Harrison), and in October, 1876, in enormous quantities. I also collected it at Fort Washington, on the Hudson river, on New York Island, where the water is salt; at High Bridge, New York Island, where the water is also salt, and grew them in salt, brackish, and fresh water. Thus I was enabled to study the Diatoms living and in different densities of water. I made other collections and studied them in the same manner. I have now to record the results.

*Homæocladia filiformis* was founded by W. Smith in 1856 (Syn. Brit. Diat. vol. II., page 80, pl. LV, 348), as "V. linear-lanceolate, somewhat acute," and var. b., "a smaller form." I have it from Newark, N. J., Sept., 1872, Sept., 1874, Oct., 1876, Aug., 1889, Sept., 1889, and Aug., 1891; Jersey City, N. J., July, 1889, the Hackensack river, Sept., 1889, a stream (fresh) running down by Mt. Pleasant cemetery, Newark, N. J., and in the M. and E. canal (fresh water from Lake Hopatcong, N. J.), Aug., 1890. Dr. Walker Arnott told me he had it from fresh water in the Monkland canal near Glasgow, Scotland, 165 feet above the level of the sea. I now have it growing in fresh, brackish, and salt water. W. Smith refers it to brackish water, and gives but two localities, Bexhill in Sussex and near Lewis. So it would seem to grow in fresh, brackish, and salt water, and always in a frond or tube of hardened gelatinous matter. I have it growing free without a frond or tube.

*Homæocladia sigmoidea* was founded by W. Smith in 1856 (Syn. Brit. Diat. vol. II, page 31, plate LV, fig. 349), as "F. V. sigmoid; v. linear, attenuated towards the extremities." Always occurring in a frond or tube, growing in brackish water; and he gives but one locality, Wareham, Dorset. He says: "The species are all marine, and appear to be rare, as few British localities are known to me, or have been given by the former authors," showing that he collected but rarely and in a circumscribed locality.

*Homæocladia Martiana* was founded by C. A. Agardh in 1827, and he gives it as marine and Venice as the locality. It had been described by C. A. Agardh as *H. Martiana* and *H. Anglica* in 1830, and growing at Plymouth, England. W. Smith says it is "a rare form," and gives Mr. Ralfs credit for uniting the two species.

In 1844 F. T. Kützing founded the genus *Raphidogla*, and gives four species, *R. medusina*, from the Gulf of Naples, *R. manipulata*, from the Gulf of Genoa, *R. interrupta*, from Trieste, and *R. micans* (which is *Bangia micans*, H. C. Lyngbye, 1819), from the Danish coast.

C. A. Agardh founded the genus *Homœocladia* in 1830, and gives two species, *H. Martiana*, locality, Venice, and *H. Anglica*, locality, Plymouth; and F. T. Kützing describes six species, *H. pumila* = *Schizonema pumila*, C. A. Agardh, locality, the Adriatic; *H. moniliformis*, F. T. K., 1844, locality, Trieste; *H. Anglica*, C. A. A., locality, Plymouth; *H. Martiana*, C. A. A., 1827, locality, Venice; *H. arbuscula*, F. T. K., 1844, locality, Venice, and *H. dilatata*, F. T. K., 1844. L. Rabenhorst in Flor. Eur. Alg., 1864, gives *H. Martiana*, C. A. A., b. *anglica*, C. A. A., c. *Arbuscula*, F. T. K., d. *dilatata*, F. T. K., e. *moniliformis*, F. T. K., *H. filiformis*, W. S., b. *forma parva*, W. S., *H. Bulnheimiana*, L. B. (Alg. N., 1301), *H. pumila*, C. A. A., *H. penicilata*, F. T. K., 1849 (Sp. Al., page 97), *H. lubrica*, F. T. K., 1849 (Sp. Al., page 98), which are the "Frustula recta," and *H. sigmoidea*, W. S., and *H. Vidovichii*, A. G., 1862 (Wien, *Verh.*, page 586, tab. xii, fig. 32), which are the "Frustula sigmoidea."

Now all these species, with the exception of *Bangia micans*, C. H. L., are one, and, as the formation of a frond or tube is not generic, they are but one species of the genus *Nitzschia*, A. H. H., 1845 (Brit. Fr. Alg.). But I think they can be with reason referred to *Sigmatella*, F. T. K., 1833 (Alg. Dec.). As to the specific name, *Martiana*, C. A. A., is the oldest, and must stand.

I have *H. Martiana* from Beaufort, S. C., where I gathered it. It grows on oysters (*Ostrea Virginica*), and I have *H. Sigmoidea* from E. Newark, N. J., Aug., 1889, Sept., 1889; Harrison, N. J., July, 1890; Waverly, N. J. (fresh water), Aug., 1890, a stream running down by Mt. Pleasant Cemetery, Newark, N. J. (fresh water), Sept., 1890; head of the same stream near Belleville avenue, Newark, N. J., Sept., 1890, and in the Passaic river (salt water), Sept., 1890, and in the same place Aug., 1891.

Now as to the genus. I have already given the reason for not accepting *Homœocladia*. And as W. Smith says, "the structure of the frustule, which is that of the genus *Nitzschia*," it cannot be classed as a separate genus on account of the presence of a frond or tube; and, as I have said, I prefer to class it as *Sigmatella*, F. T. K. As to the species, *Raphadoglaea medusina*, F. T. K., is with short frustules; *R. manipulata*, F. T. K., is with long and also short frustules; *R. interrupta*, F. T. K., with short frustules; *Homœocladia pumila*, F. T. K., with short frustules; *H. moniformis*, F. T. K., with very long frustules; *H. anglica*, C. A. A., and *H. Martiana*, C. A. A., with very long frustules, and *H. arbuscula*, F. T. K., and *H. dilatata*, F. T. K., also with long frustules. In the gathering at Harrison, N. J., I have the long and short frustules in the same tube, showing that they are the same species. The large form seems to be the sporangium and the small one the normal. But this must be proved by watching the process of conjugation, which has not as yet been seen. And, now, as to the species. I have shown that *para-*



*doxa*, O. F. M., is the species. I cannot as yet prove the specific change from *Homæocladia filiformis* to *Bacillaria paradoxa*, but they are both common in the Passaic river at Harrison, N. J., and evidently, when viewed carefully, are seen to be the same. The size of the frustule is large and small; they are both the same shape, and the only difference between them is that one (*H. filiformis*) is in a frond or tube, and the other (*B. paradoxa*) is free and moving, but also commonly still. In fact, as W. Smith says, "the frustules of *Bacillaria* are those of a *Nitzschia*." It seems to be a form of the species that is for the distribution of the species in place, for *Homæocladia filiformis* is fixed by reason of the frond, and *Bacillaria* can only be the motile form, and can travel up the stream into fresh water where the water is stiller than in the ocean. Or it may be the motile form (*Bacillaria*) can travel down the stream best and becomes fixed (*Homæocladia*) in the ocean. In fact this brings up the point of determining the origin of *Diatomaceæ* generally. Were they created in the ocean or in fresh water? I believe they were created in fresh water. For when they were formed there was no salt water. The rain that fell was of course fresh water, and lakes and sea were formed of fresh water. Then after a time, or immediately, salt (sodium chloride) was formed from the hydrogen chloride (Hydrochloric acid) and sodium carbonate, or some other salt of sodium, present on the earth, and thus the sea became salt. The ocean that formed in Utah and Colorado was Eocene and fresh water, and I have called it the Occidental Sea. (Vide my paper on the Diatoms of the Pacific States in the American Journal of Science for November, 1891.) But this carries us into the geology of the *Diatomaceæ*, which I do not mean to go into at the present time. Nor yet the origin of the *Diatomaceæ* themselves, whether they are vegetable or animal, or Protista or what. But I will say that if they can be classed anywhere I am of the opinion that they must be classed as Protista at present, viz., organisms that exist as free beings, without differentiation from vegetables or animals; that do not have a stomach, that breathe carbon dioxide, and reproduce by the union of spermatozoids (or male organs) with female organs. But this brings us again to a difficult subject to treat of, the genesis physiologically of the *Diatomaceæ*. I do not desire either to go into this, but I have for years been investigating their physiology and think I have cleared up the way, until some patches of dawn at length are seen.

But the species and genus of the forms we have been treating of is about this genus, *Sigmatella*, F. T. K., 1833, and species *paradoxa*, O. F. M., 1788. I very much doubt if this species is not the same that has been called *Synedra* (*Nitzschia*) *sigmoidea* or *Bacillaria sigmoidea*, D. C. L. N., 1817. Having now cleared up the genus *Sigmatella* (*Nitzschia* or *Synedra*), we

shall do the same with a seemingly more difficult but really more easy group or genus of *Diatomaceæ*, the *Schizonema*. The genus *Schizonema* was founded by C. A. Agardh in 1824 (Bot. Zeit.), and forms naviculoid frustules commonly existing in the ocean or salt water in fronds or tubes. But they can, for the same reason which I have shown in *Homæocladia*, be classified as *Navicula*. Then we come to the species. As W. Smith says, "the fronds of this extensive genus were among the earliest Diatomaceous organisms recognized by naturalists, and have been the perplexity of all subsequent observers." He points out that "their external form, size, and color vary with age, season, and locality, and in consequence any characters based alone upon these particulars are uncertain and deceptive." The genus must be grouped together under *Schizonema*, C. A. A., 1824. By R. K. Greville, 1826, under *Schizonema* and *Monema*; by C. A. Agardh, 1830, under *Schizonema* and *Micromega*; by C. G. Ehrenberg, 1838 (Infr.), under *Nononema*, and now as *Navicula*. With the exception of *Schizonema cruciger*, W. S., 1856, which is now classed under *Pleurosigma*, W. S., by most observers, we can group the twenty-four *Micromega*, F. T. K., 1844, under one head or species of *Navicula fatida*, J. E. S., 1790-1814, which is *Ulva fatida*, J. E. S. That we will class the *Colletonema*, A. de B., under this group along with *Berkleya*, R. K. G., and *Dickieia*, J. R., is most certain, I think. For they are formed in fresh water as *Colletonema neglectum* or *C. vulgare* or *C. subcoharens*. These are placed under *Pinnularia (Navicula) radiosa* and *Navicula crassimervia*. But this part of the subject I do not wish to go into at the present time.

I have the very large, middling, and small forms growing in one tube at the Passaic river, Newark, N. J., and Hudson river at Fort Washington, N. Y., and growing with the *Schizonemas*, in the same tube, is the *Homæocladias* as I have designated. Now what can we say is a species in the *Diatomaceæ*? The species cannot exist, and the genus breaks down, when we come to apply the same mode of reasoning to that. In fact the whole family of *Daitomaceæ* will break down, I think, when we come to apply it to that also.

### Radiolaria: Their Life-History and Their Classification.

BY REV. FRED'K B. CARTER,

MONTCLAIR, N. J.

[Continued from page 180.]

Finally if your form is a *flat* disk and the surface of the disk on the flat slides is covered by a porous sieve plate and the chambers of the rings are imperfectly divided by the radial beams it is either *Porodiscus* (= *Flustrella*), *Perichlamydidium*, *Stylodisc-*

*tya*, *Hymeniastrum*, or one of its two allies. If there are no spines or chambered arms it is either the first or second, and an equatorial girdle will make it *Perichlamydidium*. *Stylodictya* has 5 or more spines. *Hymeniastrum*, *Histiastrium* and *Stephanastrum* have radial chambered arms with or without solid spines at the ends; the first has 3 arms, the second and third 4. *Stephanastrum* may be known by the presence of a terminal girdle.

The student will note that some of these genera are very much alike. *Hymenactura* and *Hymeniastrum* both have 3 radial chambered arms and connecting membrane or network between the arms, *Stauractura* and *Histiastrium* both have 4 such arms and connecting membrane. So that it is hard to distinguish these genera respectively. The point to note especially is whether the surface is convex, *i. e.*, lens-shaped, or comparatively flat. If the former, it is *Hymenactura* or *Stauractura*, as the case may be; if the latter, *Hymeniastrum* or *Histiastrium*. The presence of the porous sieve plate is also another mark by which to recognize *Hymeniastrum* and *Histiastrium*.

Passing now to the second group, which is as a rule characterized by the presence of one large mouth or opening instead of many small ones, we have these 36 genera to consider:

<i>Lithocircus</i> ,	<i>Dictyocephalus</i> ,
<i>Zygocircus</i> ,	<i>Pterocanium</i> ,
<i>ZygoStephanus</i> ,	<i>Pterocodon</i> ,
<i>Acanthodesmia</i> ,	<i>Podocyrtis</i> ,
<i>Semantis</i> = <i>Stephanolithis</i> .	<i>Thyrsoyrtis</i> ,
<i>Halicalyptra</i> ,	<i>Dictyopodium</i> ,
<i>Cornutella</i> ;	<i>Lithornithium</i> ,
<i>Dictyophimus</i> ,	<i>Rhopalocanium</i> ,
<i>Lithomelissa</i> ,	<i>Lithochytris</i> ,
<i>Lychnocanium</i> ,	<i>Cycladophora</i> ,
<i>Lithopera</i> ,	<i>Calocyclus</i> ,
<i>Sethamphora</i> (= <i>Cryptoprora E.</i> ),	<i>Eucyrtidium</i> ,
<i>Anthocyrtoma</i> ,	<i>Lithocampe</i> ,
<i>Anthocyrtis</i> ,	<i>Petalospyris</i> ,
<i>Anthocyrtium</i> ,	<i>Ceratospyris</i> ,
<i>Anthocyrtidium</i> ,	<i>Cladospyris</i> ,
<i>Carpocanium</i> ,	<i>Lithobotrys</i> ,
<i>Lophophæna</i> ,	<i>Botryocyrtis</i> .

A formidable array certainly but not so hard to master as would appear at first sight, since they admit of several subdivisions very plainly marked. Thus in the first five of the above genera the skeleton is

#### A RING OR COMBINATION OF RINGS.

In *Lithocircus* and *Zygocircus* there is but a single ring and branched spines distinguish the former.

In *Zygostephanus* and *Semantis* there are 2 rings. The former has 2 rings complete, perpendicular to one another, the latter a vertical ring bearing on its base a horizontal ring.

And in *Acanthodesmia* there are 3 rings, 2 incomplete meridional rings, both truncated by a complete horizontal basal ring.

In the next 26 genera the skeleton is

CONE-SHAPED AND HAS BUT ONE CHAMBER.

If the shell is *not jointed* it is either *Halicalyptra* or *Cornutella*. The mouth of the former is surrounded by feet; the shell of the latter is composed of lattice-work and dilates towards the mouth.

If the shell is *2-jointed* it is one of the next twelve genera in the order given above.

*Lophophæna* and *Dictyocephalus* have *no* radial appendages, and the latter has no horn, while the former has 2 or more.

*Dictyophimus*, *Lychnocaniun*, *Lithomelissa*, and *Lithopera* have 3 radial appendages. If the mouth of the thorax is closed it is the last. Here we have an exception to the general rule of the second group, namely, the presence of one large mouth or opening. The general shape of the form, however, will enable the student to locate it in this group.

*Lychnocaniun* has 3 feet on the *mouth*, *Dictyophimus* 3 ribs on the *thorax* also, while in *Lithomelissa* the 3 ribs on the *thorax* are prolonged into *wings*.

The remaining 6 genera have *numerous* radial appendages. *Sethamphora* has smooth radial ribs enclosed in the wall of the thorax. The rest have no ribs in the thorax and *Carpocaniun* has no horn and the cephalis or 1st joint is but slightly developed, while in *Anthocyrtoma* and allies the cephalis is well developed and has a horn at the top.

*Anthocyrtoma* has 6 feet around the mouth, *Anthocyrtis* 9, *Anthocyrtium* 12 or more. Feet outside the restricted mouth distinguish *Anthocyrtidium*.

If the shell is *3-jointed* it belongs to the next 10 genera of the preceding list. And from 4 to 9 radial appendages will make it either *Cycladophora* or *Calocyclos*, the mark of the latter being the presence of feet around the mouth. The rest have only 3 radial appendages. Here again we are helped by an additional fact. If the mouth is *closed* it is *Lithornithium*, *Rhopalocaniun* or *Lithochytris*. The first has 3 wings on the *thorax*, the second 3 wings on the *abdomen*, the third has 3 terminal feet and is pyramidal. But if the mouth is *open* it is one of the other five. *Pterocaniun* has 3 ribs prolonged into 3 terminal feet, *Pterocodon* 3 free wings on the thorax and numerous terminal feet. *Podocyrtis*, *Thyrsoyrtis* and *Dictyopodium* have free appendages only on the abdomen. In the first the feet are solid and simple, in the second solid and ramified, in the third latticed.

If the shell has 4 or more joints it is either *Eucyrtidium* or *Lithocampe* and the presence of a horn on the cephalis marks the former.

Next we come to 3 genera in which the skeleton has

#### TWO CHAMBERS.

In these there is neither abdomen nor thorax, only the two-lobed cephalis, and the characteristics are as follows: *Petalospyris* has one horn, *Ceratospyris* many, while *Cladospyris* has branched or forked spines, or the edges of the appendages are serrated. Ehrenberg figures still other forms without horns or spines, or with only one small horn or short projecting teeth, which he assigns to the genus *Dictyospyris*, but Haeckel, if I remember right, makes no mention of any such genus.

And finally we have 2 genera in which the skeleton has

#### MANY LOBES OR CHAMBERS.

These are *Lithobotrys* and *Botryocyrtis* and the former may be recognized by the presence of tubes on the cephalis.

(To be continued.)

---

## MICROSCOPICAL APPARATUS.

---

**Edinburgh Student's Microscope.**—This instrument, made by Messrs. W. Watson & Sons of London, England, is exactly identical in all working parts with the well-known Edinburgh Student's Microscope, except that it is mounted on a tripod form of foot as illustrated in the frontispiece. The Continental or horseshoe pattern is exceedingly popular, and is invariably preferred by and recommended to students, as, owing to its compactness, the instrument is rendered extremely portable, but it is not so perfectly rigid in all positions to which the instrument may be inclined for working (especially if the table on which it is placed has inequalities of surface) as the tripod form of foot. This latter is strongly recommended by eminent microscopists, including Dr. Dallinger and Messrs. E. M. Nelson and Andrew Pringle. It undoubtedly gives the maximum of rigidity, and has a very commanding appearance.

This microscope is strongly recommended for photomicrographic purposes, and, owing to the perfection of all the adjustments, especially the fine adjustment, the highest powers may be used and the most delicate research conducted with it. The workmanship throughout is of the very finest quality, and for convenience of design the instrument is unsurpassed.

The following are some of the special features of the instrument:

The fine adjustment is the improved form. One revolution of the milled-head moves the body  $\frac{1}{3000}$  of an inch, and as it is sensitive to the  $\frac{1}{1000}$  of a turn, a motion of  $\frac{1}{30000}$  part of an inch can be obtained. The body carries the Continental size eye-pieces and with draw-tube closed is of Continental length. The draw-tube, which is graduated to centimeters, when out to its full extent makes the length of the body 10 inches. The inside diameter of the top of the draw tube is smaller than the remainder, the former making a fitting for the eye-piece about 1 inch long, permitting of the tube being blacked inside up to this fitting, and so minimizing reflection. The lower end of the draw-tube is provided with a screw of the universal size, so that the lowest powers may be used. The stage is of extra large size, being  $3\frac{1}{2}$  inches square, so allowing of the use of large slips, etc. It is mounted at a convenient height for support to be given to the hands, when manipulating the object, and, being below the centre of the inclining joint at the top of the foot, a perfect balance of the parts is obtained. The fitting for under-stage apparatus is hung on a pivot, allowing of it and the apparatus contained in it to be at once turned aside (leaving the mirror free for use) and replaced as required. The mirrors are plane and concave, and are mounted on a swinging arm, permitting of their being swung aside for photography, also allowing of light being thrown on the object very obliquely. They are also adjustable to focus by means of a sliding fitting. The fittings are all of universal size. The eye-pieces have nickle-plated tubes to prevent tarnishing. All the movements are fitted with screws, which, by being very slightly turned, compensate for wear and tear caused by friction.

This instrument is also made in the binocular form, or if made to order the body can be furnished of any desired large size. In short, the instrument is complete, with every mechanical convenience, as supplied to leading microscopists, professors, etc., throughout the world. (See frontispiece.)

---

### MICROSCOPICAL NEWS.

---

**The microscopic determination of rock-forming minerals.**—A book, in Russian, by F. Loewinson-Lessing, bearing this title has been published in St. Petersburg. It contains tables of the rock-forming minerals based on the writings of Rosenbusch, Michel Lévy, and Lacroix as well as of Doelter and Hussak. If you know the characters of the mineral, the book enables you to determine its name. One table is based on examination with polarized light. Others depend on external morphological characters, the crystalline systems and other optical characters. About 80 of the most practically important minerals are included and all others are excluded.

## MICROSCOPICAL SOCIETIES.

SAN FRANCISCO, CAL.—WM. E. LOY, SEC'Y.

May 4, 1892.—President Breckenfeld presided, and during the evening spoke of the hurried visit to this city of Dr. A. C. Stokes, of Trenton, N. J. After the reading of the minutes and the disposal of the routine business, George Otis Mitchell exhibited a novel and inexpensive collecting apparatus he had lately constructed, with slight modifications from those heretofore used. It consists of two wired tin rings, the outer slipping over the inner and securing the net of bolting cloth. The net narrows downward, the lower end being the size of a wide-mouthed two-ounce bottle, around which it is fastened with a piece of cord. A socket fastened to the ring is of a size admitting the ferrule of a walking-cane, which enables the collector to sweep through the water at a considerable distance from the shore. Mr. Mitchell thought a collecting apparatus of this kind would often secure specimens of animal and vegetable life, when the most assiduous work with the ordinary method would show nothing of interest, or only such as are very numerous. With his apparatus he was enabled to secure quantities of that most beautiful and elusive fresh-water alga, *Volvox globator*, at any time he chose to take a dip in Mountain Lake.

The paper of the evening was read by R. H. Freund, on "The Differential Staining of Cover-glass Preparations by Eosin." He said aniline dyes were of two groups—the basic and the acid. To the first belonged methyl-violet, gentian-violet, methyl-blue, vesuvin, fuchsin, and a number of others. To the second group belonged the derivatives of the fluorescein group—eosin, methyl-eosin, cocein, pyrosin, and aurantia. Koch and Weigert have used the selective affinity of the basic colors for staining and differentiating bacteria, and, taking Koch's researches as the base, Ehrlich has succeeded in utilizing them in staining and differentiating the cellular elements of the blood. He gave his method the name of the Tinctorial or Color Analysis, asserting that certain dyes under all conditions produced invariably the same effect on some cell elements, with the certainty of a chemical experiment; in fact he claimed that the result obtained was a chemical compound formed between the dye and the object brought in contact with it.

A number of years ago Waldeyer (*Archiv für Mikroskopische Anatomie XI*) observed that on different places on the loose connective tissue are to be found large, round, coarsely-granular cells, which he called embryonal or plasma cells. He asserted that these cells had a disposition to absorb fat, and that in time they might degenerate into fat cells. Investigating Waldeyer's observations, Ehrlich found that these cells have a disposition to absorb and retain certain aniline colors; and following up his ex-

periments, he found that an analogous reaction takes place with certain granular elements of the blood. That Ehrlich's researches are not better known is due to the fact that until last year his published observations were scattered through the different medical journals; but now he has collected them into a volume, "The Histology and Clinic of the Blood and Relations to Color Analysis."

Mr. Freund's paper gave a very careful résumé of the subject, and he explained to his hearers his own method of preparing, staining, and mounting blood. His paper was further illustrated by a number of preparations shown under microscopic amplification of 1,200 to 2,000 diameters. Among these were two beautiful slides prepared by Dr. Bein of Berlin.

After the reading of the paper an interesting discussion took place, in which Dr. Wythe, Dr. Sanderson, and others took part. It was asked whether any *ante-mortem* treatment of the blood would facilitate its study, to which Dr. Wythe replied that a guinea-pig could be fed for weeks with sulpho-carbolate of soda in its food, and when killed the blood could be treated with numerous reactionary elements, which would yield beautiful and permanent stains.

The next meeting of the society, two weeks hence, will be for a public exhibition, when, it is anticipated, many interesting objects will be shown.

May 18, 1892.—The members and friends of the society, numbering about seventy persons, responded to the invitation to attend the first public exhibition to which ladies were admitted since the society has occupied its present quarters at 432 Montgomery street. Although the night was uncomfortably warm, the interest in the exhibit never flagged, and every one went away feeling amply repaid.

The names of the exhibitors, with their principal exhibits, were as follows:

Dr. S. M. Mouser showed the circulation of the blood in the mesentery of the living frog. Although this wonderful operation of nature has often been shown, it is generally the chief attraction.

Dr. Henry E. Sanderson exhibited half a dozen anatomical preparations from man and the lower animals of his own mounting.

Charles C. Riedy showed some gorgeous opaque objects, a slide of arranged butterfly scales, gold-plated diatoms and the diamond beetle being the chief attractions.

A. H. Breckenfeld made a successful exhibit of living fresh-water organisms, such as infusoria, polyzoa, mites, etc.

E. W. Runyon had on his stand various polarizing objects, including human hair, crystals of strychnia, and fibers from Egyptian mummy-cloth.

A. M. Hickox showed some brilliant objects with polarized light, including oxalic-acid crystals, sugar crystals, quartz, etc.



Dr. J. M. Selfridge exhibited very handsome and interesting mineral crystals in a natural state, such as cinnabar, carbonate of copper, cinnabar crystals with celestine, etc.

A. S. Brackett had under his microscope various transverse sections of vegetable growths, stained and double stained, including the petiole of the horse-chestnut, growing point of the fig, stem of the tulip tree.

Colonel C. Mason Kinne showed the breathing organs of certain animals and plants, as spiracles of insects, stomata of plant, branchial plate of oyster, etc.

Professor E. J. Wickson exhibited various plant diseases, or fungus growths—rose mildew, rose rust, and hollyhock disease.

M. E. Jaffa showed a number of chemical crystals and starch grains.

#### QUEKETT CLUB, LONDON, ENGLAND.

303d meeting, June 17, 1892.—Met at 20 Hanover Sq., Dr. Dallinger, the president, being present. H. W. King read a paper on *Monstera deliciosa*, a climbing plant possessing some peculiarities of microscopic interest.

Mr. Ingpen read a note on Wenham's method of obtaining broad illumination of structures, such as scales and diatoms, under high powers. The apparatus was exhibited and explained. Mr. Ingpen also commended Marshall's zoophyte trough or life-cell for more general use. A new colored rotifer was exhibited by G. Western. The club then adjourned for the summer.

---

### NEW PUBLICATIONS.

---

*Outlines of Entomology.* By Mary E. Murtfeldt. Svo, pp. 135.  
Published by the author, Kirkwood, Mo.

This work was originally prepared at the request of the State Board of Agriculture of Missouri and embodied in its proceedings, but the author has had copies bound and offers them for sale at fifty cents each. It is a delightful book and one that is simple, easily understood and therefore attractive. It has been prepared by a writer learned in her specialty and one who has justly earned an enviable reputation. Primarily prepared for the use of farmers and horticulturists to teach them to recognize their friends and enemies among the insects, it contains much that is of interest to every intelligent person fond of the out-of-doors world. The author has written the book remembering, as she says, "that there are those who have yet to learn the difference between a beetle and a bug, or between a moth and a butterfly; to whom the transformations of insects offer a puzzle which they cannot solve, and who are completely daunted and discouraged by a half dozen successive technical terms." Miss Murtfeldt has prepared a little treatise which can be cordially commended to any one having the least interest in the subject.

*Lessons in the Diagnosis and Treatment of Eye Diseases.*  
By Casey A. Wood, M. D. Sq. 16mo, pp. 154. Detroit:  
Geo. S. Davis. Price, 25 cents.

This is intended for the use of the busy practitioner that is not a specialist, and it fairly well accomplishes its object.

*Living Matter: Its Cycle of Growth and Decline in Animal Organisms.* By C. A. Stephens. 16mo., pp. 107. Norway Lake: The Laboratory Co.

This little volume is, as the author says, a résumé of an extended investigation into the causes of old age and organic death, especially of the human being. The subject is treated as a philosophical study, the author beginning with the consideration of universal matter, which he says feels; "hence the universe has everywhere a low degree of sensory perception. . . . The earth lives in a certain sense; not the self-conscious life of an animate organism, yet sentient in a low degree." Protoplasm, or biogen, as the author prefers to call it, accepting the word invented by Dr. Cones, is treated after the manner of the chemist and psychologist rather than of the naturalist and microscopist, and after a somewhat extended consideration of the anatomical changes which accompany old age, he concludes that life is never qualitatively but only quantitatively diminished; that death comes not from a decline of initial vital power, but from extrinsic obstacles which befall from material surroundings and from imperfect modes of living. "Death comes not from a law of Nature, for the law of Nature is life. Universal matter lives from eternity and never dies." "A tissue is old because there is little biogen in it, not so much because the biogen has grown intrinsically weak." The human being inclines toward death, according to Mr. Stephens, from three principal causes: by reason of minute mechanical and chemical accidents within the tissues; by physical accidents from surrounding matter, imperfect food and imperfect assimilation; and by the reaction from these as shown in discouragement and world-weariness. "Every one of these causes of death and old ageing is of the nature of an ordinary physical cause fairly within human power to avoid or remedy, and many of which in fact we are every day avoiding and remedying. It is the sum total of these causes which has heretofore rendered death a seemingly inevitable sequence to life. Yet not one of them but can be singly warded off by human science and foresight, and if one, why not all?"

To the scientist death seems as natural as life, and he seeks no reasons for avoiding it. He endeavors to learn what life is, not how it may be indefinitely prolonged, for he recognizes that from the solar system down to a naked drop of living protoplasm, a decline and death are visible from the beginning. Universal death is the law of Nature, not universal life, and the cause can be no more "warded off" by human science and foresight than human science and foresight can ward off the attraction of gravitation or the precession of the equinoxes.



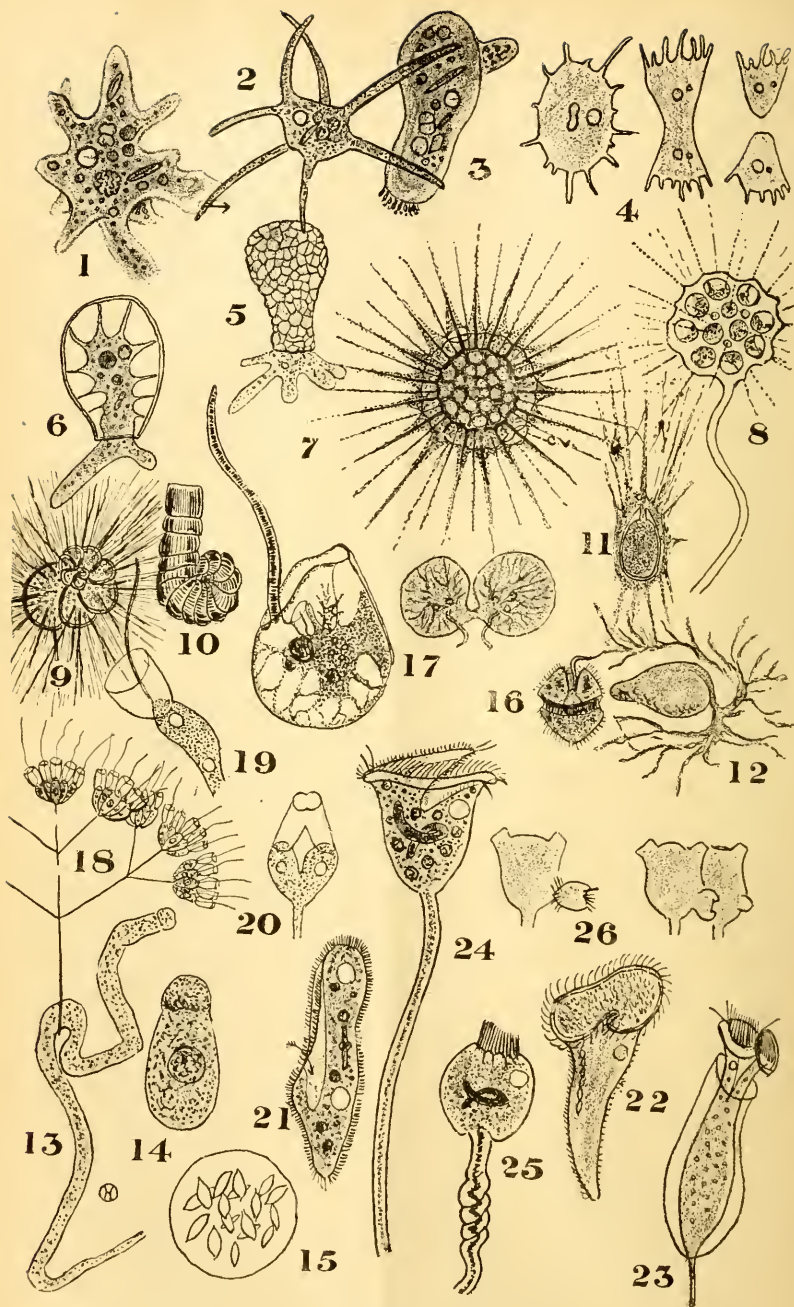

PROTOZOA.

# THE AMERICAN

MONTHLY

## MICROSCOPICAL JOURNAL.

VOL. XIII.

OCTOBER, 1892.

No. 10.

### CONTENTS.

<p>Index of Refraction (illustrated).—AUBERT - - - - 225</p> <p>Diatoms of the Connecticut Shore.—II.—TERRY - - - - 230</p> <p>The Protozoa—a Phylum of the Animal Kingdom Considered Biologically (illustrated).—OSBORN - - - - - 233</p> <p>A Bacteriological Potato-Sec-</p>	<p>tion Cutter (illustrated).—DAWSON - - - - - 243</p> <p>BACTERIOLOGY.—What Has Been Done in Bacteriology in Relation to Hygiene - - - 245</p> <p>MICROSCOPICAL SOCIETIES.—St. Louis. Lincoln - - - - 247</p> <p>NEW PUBLICATIONS.—Bausch &amp; Lomb. Stockwell - - - - 248</p>
---------------------------------------------------------------------------------------------------------------------------------------------------------------------------------------------------------------------------------------------------------------------------------	----------------------------------------------------------------------------------------------------------------------------------------------------------------------------------------------------------------------------------------------------------------------------------

### Index of Refraction.

BY A. B. AUBERT, M.S.,  
ORONO, ME.

The usual definition of index of refraction is somewhat as follows: the index of refraction of a substance is equal to the quotient of the sine of the angle of incidence divided by the sine of the angle of refraction.

A simple figure will readily make this clear.

Let A B C D (figure 1) represent the outline of a circular vessel, A C being the water-line. When the beam of light is incident along B E, which is perpendicular to A C, there is no refraction; that is, the beam passes from one medium (air) into the other (water) without being bent or refracted. When it is incident along  $m$  E, there is refraction, it is bent at E toward the perpendicular (or normal) B D, and strikes the circle at  $n$ . When it is incident along  $m'$  E there is also refraction at E, the beam striking the circle at  $n'$ . From the ends of the incident beams, let the perpendiculars  $m o$ ,  $m' o'$  be drawn upon B D, and from the ends of the refracted beams let the perpendicular  $p n$  and  $p' n'$  be also drawn.

Divide the length  $om$  by the length  $pn$ , you obtain a certain quotient; in like manner divide  $m'o'$  by  $p'n'$ , in each case you obtain the same quotient. This is a constant quantity for each particular substance, though it usually varies for different substances when compared with each other. This constant is the index of refraction of the substance. The perpendiculars  $om$  and  $pn$  are the sines of the respective angles  $mEo$  and  $nEp$ , hence calling the angle of incidence ( $mEo$ )  $V$  and the angle of refraction ( $nEp$ )  $X$ , we have the expression, index of refraction =  $\frac{\text{sine } V}{\text{sine } X}$ . The following apparatus (shown at figure 3) is well devised to demonstrate the laws of refraction; it consists of a graduated vertical circle to which is attached a glass receptacle having the shape of a half cylinder and containing a liquid whose upper surface passes through the centre of the circle. A beam of light

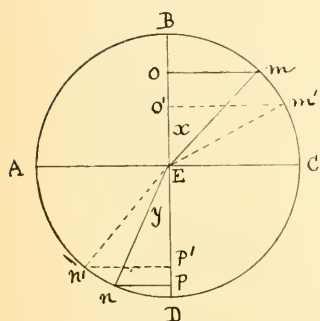

FIG. 1.

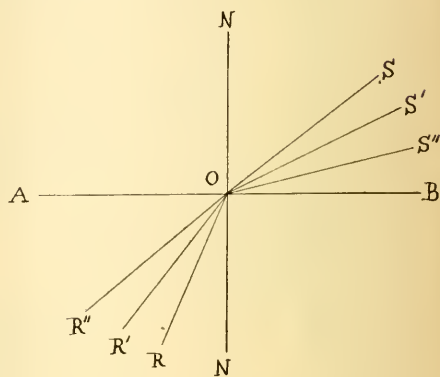

FIG. 2.\*

is reflected from the mirror I through the diaphragm D toward the centre O. The alidade  $Oa$  gives exactly the value of the angle of incidence, the beam is refracted when it passes through the liquid, and the angle it now makes is measured by the alidade  $OR$ ; this is done by moving it until the beam emerges through the diaphragm tube Z. As the beam emerges in a perpendicular direction to the medium it is not again refracted, so the alidade gives the true value of the angle of refraction. The value of the angles, in degrees, can now be read from the graduated circle, and the sines compared, and it will be found that the relationship between the sines of the angles of incidence and refraction are always the same for the same liquid; this relationship is, as before stated, the index of refraction.

In the case just examined the beam is supposed to travel from the rarer to the denser medium; the apparatus can, however, be

\* By an oversight, the beam  $OL$  is not represented in the figure. A line drawn about midway between  $AO$  and  $R''O$  will represent the beam  $OL$  referred to in the text.

equally well used when the beam travels in the opposite direction.

#### CRITICAL ANGLE.

Whenever a beam of light passes into a denser medium, no matter what the angle of incidence may be, there always corresponds to it a certain angle of refraction; such is not the case when a beam passes from a denser to a less dense medium.

Example: The beams SO, S'O, S''O (figure 2) passing into a denser medium are refracted at OR, OR', OR''. A beam making an angle of  $90^\circ$  with the normal would be refracted at OL.

Reciprocally the beams OR, OR', OR'' in passing from a dense into a less dense medium will give rise to the beams OS, OS', OS''. The beam OL gives rise to the emergent beam OB, which makes an angle of  $90^\circ$  with the normal. The angle of the incident beam LO is the critical angle; it is not refracted by passing into the medium of lesser density, but is totally reflected.

This angle may be determined for different media by an application of the formula for obtaining the refractive index, as follows:

Let the angle sought be called X.

Refractive index = Ref. Ind.

$$\text{Ref. Ind.} = \frac{\sin 90^\circ}{\sin X} \text{ or}$$

$$\text{Sine X} = \frac{\sin 90^\circ}{\text{Ref. Ind.}} = \frac{1}{\text{Ref. Ind.}}$$

(One being the sine of an angle of  $90^\circ$ .)

This (critical) angle for water is  $48^\circ 35'$ ; for glass,  $41^\circ$ .

The instruments used in the determination of refractive indices are numerous. Some are quite simple and easy of use, while others are more complicated, and greater care has to be exercised in manipulation. One of the most simple, and one that has given satisfaction in my hands, is Bertrand's Refractometer (shown at figure 4). It can be used for solids and liquids and gives the index correct to two decimal places. By the use of monochromatic sodium flame one may obtain results correct to 3 or 4 decimal places by a single reading.

Description of instrument: AB is the eye-piece carrying a lens of crown-glass of four centimetres' focus. It slides in the tube CD, which is conical at the further end, and is provided with a reticule, R, consisting of a glass disc 8 mm. in diameter, engraved with 80 divisions  $\frac{1}{10}$  mm. apart, and numbered by tens. CD slides in the tube EFFH, the lower face of which is an elliptical section making an angle of  $30^\circ$  with the axis, and carrying the hemispherical flint-glass lens L of 5 mm. radius fixed in a copper disc.

The plane surface of this lens faces outward and its centre is in the axis of the instrument. FF is a small aperture filled with

ground glass which admits light, and V is a screw to fix the tube CD when it is so adjusted that R is at the focus of the lens.

To find the refractive index of a liquid, a drop is placed upon the plane surface of L; of the rays refracted through L, those which have an angle of incidence greater than the critical angle are totally reflected at the surface of the liquid and illuminate the lower portion of the reticule; the upper part remains dark, and the position of the boundary line depends upon the refractive index. If the value of the graduations is known the index is read directly from the position of this line upon the scale.

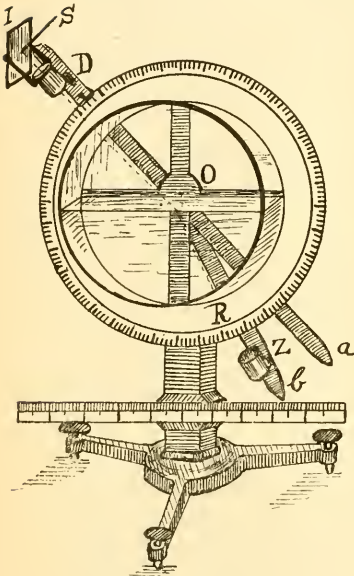

FIG. 3.

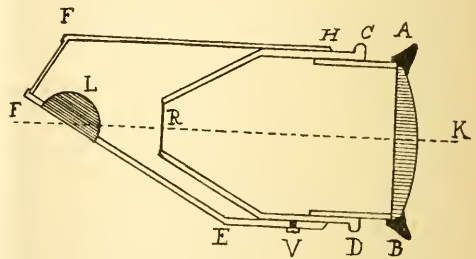

FIG. 4.

For solids, a polished plane surface is placed against the lens, a liquid of higher refractive index having been interposed between them; two boundary lines are then seen, one of which belongs to the liquid and the other to the solid; the latter gives the required index directly.

The instrument is graduated by determining the position of the boundary line for different solids and liquids of known refractive index.\*

The following is a very simple method proposed by Mr. Gordon Thompson, and which, it is claimed, yields sufficiently accurate results for the ordinary purposes of the microscopist,

A fine mark is made on an ordinary glass slide with a writing

\* Taken, in part, from Jour. Royal Micro. Soc., vol. 7, p. 469.



diamond. A large glass cover is cut in half and a piece cemented to the slip on each side of the mark, leaving a space of about  $\frac{1}{8}$  inch between their edges. A very thin cover-glass is then placed upon them, thus forming a cover to a rectangular cell, in which the liquid to be examined is placed. The fine mark is now viewed with the highest power available, and when the focus is sharp the position of the fine adjustment is noted. The slip is then removed, another fluid substituted, using the same cover-glass, and the operation is repeated. The change in the focal adjustment required is a measure of the difference in the refractive indices of the two liquids. In this way the relative refractive powers of two or more media can be immediately determined.

To measure the absolute index of refraction of a fluid it is necessary to obtain a numerical value of the graduations of the fine adjustment. To do this, choose two liquids of known refractive power, one of low index, as water, and the other of high, as oil of cassia. Focus through them both successively, and note the alteration of focus required. The indices of the fluids being known, a value for each division of the fine adjustment is easily obtained by calculation.

Another simple and quite inexpensive device for testing the refractive index has been described by Prof. H. L. Smith. The necessary apparatus consists of an adapter about  $\frac{3}{4}$ -inch long, with society screw outside and inside. A horizontal slot is cut into each side of the adapter; through these slots are made to glide two slips of crown-glass (2 in.  $\times$   $\frac{1}{2}$  in.), having very approximately the refractive index of ordinary cover-glass. In one of these slips, near the end, a concave is ground, at least  $\frac{1}{3}$  the thickness of the glass, and polished. The adapter, with slips, is attached to a microscope and carries a 1-inch objective. To graduate the instrument for use as a refractometer, make a mark on the rack-bar when the focus is perfect for an object, viewed with the 1-inch objective, and the slides so arranged that the end without concave is within the adapter; this mark represents a refraction index of 1.52; now fill the concave with oil of cassia, push the slip into the adapter so that the concave is within; focus the object carefully and make another mark on the rack-bar; this represents a refractive index of 1.6+; by doing the same with water you get the point which represents a refractive index of 1.33; glycerine gives the position for a refractive index of 1.41. The extremes may be one-half inch apart. By interpolating, quite a complete graduation can be obtained, sufficient, at any rate, for the ordinary use of the microscopist.

This little apparatus was particularly devised to test homogeneous immersion media and has been called Professor Smith's Homotester. A good immersion fluid should give best focus at the 1.52 mark, and the image should be as free from color as possible.

**Diatoms of the Connecticut Shore.—II.**

By W. A. TERRY,

BRISTOL, CONN.

The salt meadows or marshes of the Connecticut shore, as far as I have been able to examine, consist of a bed of coarse peat some four feet in thickness, lying upon a marine deposit of whitish clay and sand containing diatoms. This deposit is sometimes over thirty feet thick and occupies the bed of ancient estuaries. The rocky ridges near New Haven are mostly trap dikes, but at Fair Haven is an outcrop of the old red sandstone; eastward, at Stony Creek and Leete's Island, the rocks are granitic, somewhat resembling the so-called Scotch granite. The Quinnipiac meadows are northeast of New Haven, and extend from Fair Haven to North Haven; being five or six miles in length, and about one and a half miles in breadth, having eight or ten square miles of surface which is under water at high tide. Through this marsh the Quinnipiac River winds its sinuous course. On its western margin, on the line of the Hartford and New Haven R.R., are numerous brick-yards, which procure their clay from pits of considerable size dug in the marsh, from which the tide is kept out by dikes and which are drained by steam pumps. On the west and north the clay bed is overlaid by ordinary drift, but on the east and south it runs under the marsh. The "fat" clay used for bricks is laid down in undulating strata, varying some six or eight feet in height. Upon this is a mixture of similar red clay with sand called "delf," whose surface and strata are nearly horizontal. Upon this clay lies a bed of coarse white sand from two to four feet thick; neither clay nor sand contains any diatoms. Upon the sand is a deposit of black alluvium about one foot thick containing *fresh-water diatoms*. On this is a stratum of loam containing the roots of trees, with their trunks lying beside them, the whole covered with about four feet of coarse peat and two feet of water at high tide. Among and upon the tree trunks is a deposit of white clay and sand containing *marine diatoms*, and this extends upward through the peat to the surface. The stratum of fresh-water diatoms is therefore about eight feet below the present sea level, and is covered with about six feet of marine deposit. The fresh-water deposit is not rich, and the forms are much broken; *Pinnularia lata* being the most abundant and almost the only one remaining entire, although fragments of other *Pinnularia* and of *Stauro-neis acuta* are plentiful. The marine deposit varies considerably, some parts of it being very rich; deep-water forms are more abundant at the bottom, and brackish-water near the top. It appears evident that this region once occupied a higher level, and after the glacial period, was the bed of a fresh-water lake, which filled up or was drained and became dry land covered by a young forest growth, then suddenly sank and was submerged beneath tidal waters; the trees died and their trunks decayed at the water

line and fell and, lying beside their undisturbed roots, they were covered by the marine deposit. The varieties found in this deposit are very numerous and very interesting, some of them being new. Forms of *Navicula constricta*, *N. elliptica*, *N. latissima*, and many others are abundant. *Pinnularia æstuarii*, *Pleurosigma* (*Colletonema*) *eximium*, and other rare forms are plentiful. One of the new varieties has been named by Prof. Cleve "*Caloneis Wardii*," in honor of Dr. D. B. Ward, of Poughkeepsie, N. Y., who first called attention to it, having photographed it, with other rare varieties, from one of my slides of this deposit. Other new forms will be named and described in papers now in preparation. I quote the following determinations from the series of J. Tempere and H. Peragallo; the samples sent were from the southern or Davis' Pit:

No. 275. QUINNIPIAC RIVER (DEPOSIT).

Actinocyclus Ralfsii Pritch.	Nitzschia obtusa Sm.
Actinocyclus undulatus E.	Nitzschia plana Sm.
Amphora Clevi Grun.	Nitzschia scalaris Sm.
Auliscus sculptus E.	Nitzschia sigma Sm.
Brebissonia Bœckii Grun.	Nitzschia Tryblionella Grun.
Campylodiscus Echeneis E.	Pinnularia nobilis E. var.
Cerataulus polymorphus Grun.	Pinnularia strepto raptice Cl. n. sp.
Cerataulus turgidus E.	Pinnularia viridis K.
Coscinodiscus excentricus E.	Plagiotropis seriata Cl. n. sp. <i>grande</i>
Coscinodiscus oculus iridis E.	<i>forme liée au Pl. vitrea.</i>
Coscinodiscus radiatus E.	Pleurosigma affine Grun.
Navicula Delawarensis Grun. M. S.	Pleurosigma Balticum Sm.
Belle, <i>espèce liée au N. latissima</i>	Pleurosigma Spencerii Sm. var.
<i>et ayant la forme du N. pusilla.</i>	Pleurosigma strigilis Sm.
Navicula formosa Greg.	Rhabdonema Adriaticum K.
Navicula lyra E.	Surirella cardinalis Kitton.
Navicula peregrina K.	Surirella striatula Turpin.
Nitzschia circumscuta Grun.	

No. 276.

Amphiprora pulchra Bailey.	Navicula formosa Greg.
Bacillaria paradoxa Ginel.	Navicula latissima Greg.
Brebissonia Bœckii Grun.	Navicula peregrina K.
Coscinodiscus excentricus E.	Navicula permagna Greg. var.
Diploneis elliptica (Sm.) Cl.	Nitzschia fasciculata Grun.
Diploneis interrupta (E.) Cl.	Nitzschia obtusa Sm.
Diploneis Smithii (Breb.) Cl.	Nitzschia scalaris Sm.
Navicula approximata Grev.	Pinnularia æstuarii Cl. n. sp. <i>lié</i>
Navicula Braziliensis Grun.	<i>au p. icastauron.</i>
Navicula clavata Greg.	Pleurosigma Spencerii Sm.
Navicula Delawarensis Grun.	Pleurosigma strigosum Sm.

No. 277.

Actinocyclus Ralfsii Pritch.	Campylodiscus Echeneis E.
Actinocyclus undulatus E.	Coscinodiscus excentricus E.
Amphiprora pulchra Bailey.	Coscinodiscus oculus iridis E.
Amphora proteus Greg. var.	Coscinodiscus radiatus E.
Auliscus sculptus E.	Cyclotella striata K.

Diploneis Grundlerii.	Nitzschia sigma Sm.
Diploneis incurvata Greg. (Cl.)	Nitzschia Tryblionella Grun.
Diploneis interrupta.	Pinnularia yarrensis (Grun.) Cl.
Diploneis Smithii Breb. (Cl.)	Pinnularia viridis K.
Navicula arabica Grun.	Plagiogramma Gregorii.
Navicula Braziliensis Grun.	Plagiotropis seriata Cl.
Navicula circumsecta.	Pleurosigma affine Grun.
Navicula digito-radiata Greg.	Pleurosigma Balticum Sm.
Navicula formosa Greg.	Pyxilla baltica Grun.
Navicula irrorata Grun.	Raphoneis amphicerus E.
Navicula palpeboralis.	Stauroneis Gregorii.
Navicula peregrina K.	Surirella fostaara E. var.
Nitzschia fasciculata Grun.	Surirella striatula Turpin.
Nitzschia obtusa Sm.	

The samples furnishing the above forms were taken about four feet from the surface. Other strata furnish many other varieties, among them *Coscinodiscus subtilis*, *Triceratiua favus*, *Surirella regina*, *S. ovata*, etc. Pits some miles further north show a marked difference in the deposit. At Shares' Pit the stratum of sand is wanting, the diatomaceous deposit lying directly upon the red clay, and containing more brackish-water forms. The tidal currents flowing through the ditches in some parts of this marsh contain great numbers of living forms; at one place I find abundance of what appears to be *Pleurosigma Terryanum* and another small *Pleurosigma* that I cannot distinguish from *Colletonema eximium*, but this is not a *Colletonema* in this locality, but an independent and rapid traveller like any other *Pleurosigma*. *Melosira Borereii* grows in quantity on the short grass at the bottom of the rapid current, with *Biddulphia levis* in abundance; *Bacillaria paradoxa* makes the most remarkable showing here of any locality in which I have found it. The presence of fresh-water diatoms in these marine deposits has no special significance; the mud brought down during freshets in the rivers and streams contains diatoms from the ponds and marshes, these are distributed by the tides, and all shore deposits contain more or less of them. When living specimens are found in any quantity it shows that the water contains very little salt. In a shallow pool on the margin of the marsh into which the tidal waters flow, I find *Surirella elegans* and many other fresh-water kinds in vigorous life, and also the very small and delicate *Pleurosigma curvula* and *Amphiprora nereas*.

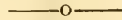

**Hæmatozoon of Malaria.**—Dr. P. Hehir, of the Nizam's Medical School at Hyderabad, has published an account of his microscopical observations on the hæmatozoon of malaria. He looks upon the hæmatozoon as a polymorphic organism.

## The Protozoa—a Phylum of the Animal Kingdom Considered Biologically.\*

By H. L. OSBORN,

HAMLIN, MINN.

[WITH FRONTISPIECE.]

It would seem very remarkable indeed, if we were not now used to the conception, that there are so few different kinds of elementary substances and so few different elementary principles. The early mind looked on all observed differences as radical and indicative of fundamental and essential unlikeness in things observed. This quality of mind persists to-day in rudimentary peoples and in the untaught and unobservant of more advanced races. But the person who lives in the light of the present era of scientific thought expects that the complex will upon inspection resolve itself into the simpler and finally into the simple. If we examine any single member of the higher groups of animals or plants, we find that, complex though they may be, their actions are the algebraic total of the powers of the multitudes of cells which compose them. Cell growth and reproduction, tissue work, division of labor, comprehend activities in plants or animals which in the total we speak of or think of as the creature's life.

Side by side with this idea of the biology of an animal or plant as the sum of the activities of component similar cells or really prior to it at the outset, though of slower growth, is the complementary conception which sees groups of animals or plants as the natural descendants of prior forms. This idea has long been struggling for existence in the world of beliefs, and cannot yet be said to have gained a permanent place among the concepts of the laity, though it is fully accepted by most professed biologists. Looked at collectively the different kinds of animals appear to be serial; that is, they are not isolated and unlike, but are more or less closely similar. The grades of similarity are somewhat parallel in different series. The groups that have been formed by the study of animals includes phyla the most comprehensive and classes, orders, families, genera, species, and varieties, named in their lessening order. Each of these groups has a name and very often the name we use in speaking of an animal is the name of its order or class, not of its exact genus or species. Thus we speak of the moth or fly or bee. In this way the same animal may be called by several different appellations, and we may speak of the

\* For the benefit of any readers who may care to look up the Protozoa more fully than the limits of this article permit, I append a few titles of works most easily accessible:

1. Encyc. Britt. Art. Foraminifera. Carpenter.
2. " " Art. Protozoa. Lankester.
3. Kent. Manual of the Infusoria.
4. Stokes. Infusoria of the United States.
5. Huxley. Anatomy of the Invertebrata.
6. Parker. Elementary Biology.
7. Leidy. Fresh-water Rhizopoda.
8. Haeckel. The Radiolaria.

The article *Protozoa*, by E. R. Lankester, in Encyc. Britt., contains a very good bibliographical index at its close.

gray squirrel as such or as a sciuroid, rodent, mammal, vertebrate animal or even living thing. We are thinking of different peculiarities in each case as we use the various names of the squirrel as representing those characters.

The fact that the correlated groups are serial among themselves and also stand in relation to other series of groups is an easily demonstrated fact and will appear at once as we examine the protozoa. The present article will be an attempt in the limited space available for the purpose to set forth the classes and orders of phylum and to examine it biologically for the purpose of discovering, if possible, the serial arrangement of its members and an explanation of the serial arrangement in biological terms.

*Amœba proteus* (see figure 1). This animal has been described so often that even a summary of its characters appears to be trite. It can easily be found on decaying submerged vegetation. It is a mass of protoplasm with nucleus and contractile vacuole and several masses of food enveloped by the protoplasm. It is sensitive to temperature and other forms of energy applied as stimuli. It has the power of thrusting out its substance in the form of transitory pseudopodia, which may arise at several different places at the same time. These may enlarge, the remainder flowing into one of them and the body thus move forward. *Amœba proteus* is not the simplest conceivable term in the series of animal and plant life. The contractile vacuole and the nuclei are both specialized portions of the protoplasm, and a still simpler condition would be presented by a cell in which the former was wanting and the latter was not differentiated from the other protoplasm. The pseudopodia are formed first in the outer clear portion or ectosarc, and this portion of the substance may not probably have motor and nervous functions, while the centre has separate anabolic functions by means of which it metabolizes food to more protoplasm. The nucleus remains permanently in the centre of the body notwithstanding the many changes of outline, and the contractile vacuole is always posterior or opposite the end toward which the animal is moving. Though the contractile vacuole, nucleus, and ectosarc must be considered to be differentiated parts of the body, *Amœba proteus* must still be regarded as a very simple animal in comparison with others of the phylum, and yet it is one from the like of which the others can be conceived to have originated.

*Amœba radiosa* (Fig. 2) is found less frequently than *A. proteus* but can often be seen in similar situations. It has a body with nucleus and contractile vacuoles, but its pseudopodia are long and tapering and remain swaying back and forth for a long time with a slow sweeping motion. They can be drawn in and the body become spherical in outline, and hence are not permanent like flagella and cilia in the Class Infusoria. This form of pseudopodia, which can be described as filamentous motile prolongations of the ectosarc, differ from the permanent organs

of the Infusoria in the degree of their activity and especially in their not persisting. The pseudopodia of *A. proteus* do not persist at all, those of *A. radiosa* persist for a time but are not permanent. A higher specialization in its molecular structure whereby this pseudopodia ectosarc would be permanent and very active would be a structure comparable with the strong flagellum of the *Dino-flagellata*, as in *Noctiluca* (Fig. 7), and *Peridinium* (Fig. 16).

*Amœba villosa* (Fig. 3) is another animal much rarer than *A. proteus*, or *A. radiosa*. Its outline bounded by ectosarc is changeable, and even to a slight extent pseudopod-forming, but its motile functions are for the most part confined to certain short and blunt processes, very numerous and located solely at one special part of the body. These give the creature its name. They are apparently a step in the direction of cilia, but with little of the perfection of cilia as they are found in such a creature as *Vorticella*. In these creatures we have three species of a single genus; all are somewhat alike, yet all are different; they are neighboring terms of a series. The same series or genus, *Amœba*, contains many other species, one of which, *A. polypodia*, is figured in the act of division in figure four. We shall find that different genera are more unlike than different species of one genus.

*Diffugia pyriformis* inhabits masses of vegetation decaying in fresh water. It is evidently advantageous for protection to be covered with a shell, and *Diffugia pyriformis* has a covering made of bits of sand joined together to form a mosaic coat shaped like a flask. This habit is matched among the annelids by *Cistenides*, or among the insects by the larva of the caddis fly, as well as by many other animals. The animal within the shell is an amœba-form being; its pseudopodia are not, however, general, but are localized, being placed only at the mouth of the shell—they are in shape like those of *Amœba proteus*; and *Diffugia pyriformis* is such an animal as would result from the habit on the part of many generations of *Amœba proteus* of using a portion of the ectosarc only for ordinary pseudopodial function and protecting the remaining portion by means of a shell. It would not be easy for *Diffugia* with its shell to divide in the same way as *Amœba* to produce new members, and it is more likely that the act is accomplished by the protoplasm independently of the shell, new shells being subsequently formed.

*Hyalosphenia cuneata* (fig. 6). If a shelly covering is advantageous for protection it will seem also advantageous to a creature to be able to produce its own. In *Hyalosphenia cuneata* we have two deviations from the amœba structure. There is first an outer shell, which, however, unlike that of *Diffugia*, is a horny or chitinous cuticle formed from a secretion thrown off by the ectosarc which hardens on the ectosarc as a mound on coming in contact with the surrounding water. And there are within the cuticle spaces in the protoplasm, "vacuoles," which are filled

with fluid, across which threads of protoplasm stretch from the centre to the fine film of protoplasm which lines the shell. This latter feature much resembles the cells of many plants and will also be seen in *Noctiluca*, and it obviously economizes protoplasm and makes greater bulk possible. Here as in *Diffugia* the pseudopodial protoplasm is located at one end of the body and nucleus and contractile vacuole are within. It is here noticeable that these three genera cannot so readily be understood as in a single series, *Hyalosphenia* being derived from *Diffugia*, as they can be understood as in two series, both starting from *Amœba*. In its chemical nature the covering of *Hyalosphenia* is interesting, being *albuminoid* and less unlike the chemical nature of compounds in the protoplasm than are the skeletons of lime or silica found in *Rotalia*, *Actinosphærium*, and many other more specialized Rhizopods. It is therefore a less specialized act of the secretory power to produce a chitinous than a calcareous or siliceous skeleton.

*Actinosphærium eichorni* (fig. 7) is found very abundantly with *Amœba* and *Diffugia*.\*

*Clathrulina elegans* (fig. 8) is stalked, a horny stem supporting a hollow horny spherical basket with large openings. Within the basket lies a ball of protoplasm, and from this, through the openings, long delicate filaments of protoplasm stretch. There is no radial skeleton.

*Lieberkuhnia* (fig. 13) is a naked body of rather definite outline, with one end prolonged into pseudopodia. The pseudopodia are never strictly radial, but are branching, the branches leading out into finer and finer divisions which often anastomose or join together. The food is caught upon the network of pseudopodia and digested there.

*Gromia oviformis* (fig. 11) has a membranous saccular skeleton imbedded in and surrounding the protoplasm which, as in *Lieberkuhnia*, is drawn out into the form of long filiform pseudopodia which anastomose frequently but are somewhat radial and lack radial supporting skeletons.

*Rotalia* has a calcareous spiral chambered shell. The protoplasm is placed within the shell, by which it is protected, and filamentous pseudopodia are thrust out through minute holes which perforate the lime. The pseudopodia often anastomose. In

\* It need not be difficult to find material for demonstrating many of these points. Very often material which at first seems barren will be found after standing a few days in a quiet dish in the laboratory to furnish abundance of many genera of *Protozoa*. It presents a central spherical mass of protoplasm which is so much vacuolated as to appear like a mass of bubbles. On each side is a contractile vacuole. The protoplasm extends in fine radial threads of the extreme tenuity and constantly circulates out and back along the threads and through the central part of the body. To support this delicate mass a shell of silicate is secreted by the protoplasm from the surrounding water; the shell consists of an internal frame-work and many radii. In this creature we find the secretory powers noticed in *Hyalosphenia* still more highly specialized, and the same is true of the vacuolation. Such pseudopodia as those of *Amœba proteus* are wanting, but the radial protoplasmic threads are comparable with pseudopodia and are more as in *A. radiosa*, though far finer. With *Actinosphærium* we reach an order of many families and genera, great variety of form and situation, many marine, but all despite their immense diversity easily reducible through *Actinosphærium* and *Hyalosphenia* to the *Amœboïd* type.



*Spirolina* (Fig. 10) another form similar in a general way to *Rotalia* is found. *Lieberkuhnia*, *Gromia*, *Rotalia*, and *Spirolina* are all marine forms; they are only a few members of the very large order *Foraminifera*.

*Peridinium uberrimum* has an oval body encircled by a shallow groove. At one end the body is pitted in and here is placed a vibratile lash or flagellum. The body is entirely destitute of a covering, except as the somewhat firmer outer portions of the protoplasm may constitute such, and the protoplasm is not vacuolated.

But the outline of the body is definite and the flagellum is very active and persists. In addition to the strong flagellum the body on its general surface bears minute active processes, believed to be of the ectosarc, which are called cilia, and which, together with the flagellum, are motor agents. *Peridinium* is thus like and unlike *Amœba*. Like *Amœba*, it is a naked mass of protoplasm with a single nucleus; like it, has motile prolongations of the protoplasm; but, unlike it, the body outline is permanent and pseudopodia are definite in position and mode of action and very active. It is possible mentally to derive *Peridinium* from an amœba-form source by imagining only a few changes, namely, a single permanent pseudopod as in *A. radiosa*, general distribution of minute active cilia somewhat as in *A. villosa*, and the permanent oval shape and equatorial depression. And this illustrates what is meant when we say that these animals are arrangeable in series in which we step from term to term with breaks, perhaps, but no very great ones.

*Noctiluca miliaris* (fig. 17) is an organism much larger than the PROTOZOA in general, being as large as a grain of clover seed. It lives in the ocean and owes its name to the peculiar power of producing light or phosphorescence which it possesses in common with a great many marine animals. In *Noctiluca* the body has the shape of a helmet. It is transparent, of fixed outline, and the outer surface, while not forming any definite and distinct shell, is firm and cuticular. The cuticle by an infolding forms a sort of cup, from within which a long and strong flagellum proceeds. The protoplasm does not entirely fill the body but is in the form of a central mass and branched threads stretching across vacuolated spaces to a thin layer lining the cuticle. Within the first cup there is a second, smaller cup, and within this a smaller flagellum; this is used in taking in food, the large lash being the organ of locomotion. There are no cilia. *Noctiluca* increases by division and figure 17<sup>2</sup> shows one stage near the end of the process.

*Codosiga umbellata* (figs. 18, 19, 20), a fresh-water animal, is unlike any of the animals thus far considered in the fact that it is a colony of similar members mechanically connected by slender stems but having no vital relation. Each member of the colony (see fig. 19) consists of a protoplasmic body with two contractile

vacuoles, and at one end a long slender flagellum surrounded by a cuticular collar or cup, recalling the smaller cup and flagellum of *Noctiluca*, and somewhat less distinctly the flagellum of *Peridinium*. The colony of *Codosiga* is sessile, the members are crowded together on the ends of ternately divided stems, which bring the members up to common level. The manner of division is shown in figure 20. *Codosiga*, *Noctiluca*, *Peridinium*, have been selected to give an idea of the order FLAGELLATA, the members of which have fixed outline of body, no stony skeleton, and one or more flagella.

*Paramecium aurelia* (fig. 21) or some other of the numerous species of *Paramecium* are sure to appear in the same standing water with *Amœba* and the other PROTOZOA already mentioned. It is an elongate, exceedingly active creature. The body is covered with a firm outer layer which is not separate from the protoplasm beneath. The body is infolded on one side. It is covered with cilia, all of the same size. These move the body and also move currents of water into the cavity just mentioned, where, at a particular place, the food is engulfed. The nucleus is rod-shaped.

*Stentor polymorphus* (fig. 22) is more rare than *Paramecium*. It is trumpet-shaped, the broad end is surrounded by cilia of larger size, and those of the body are more minute. The nucleus is shaped like a string of beads. *Stentor* lives in fresh water, and is usually attached by the smaller end.

*Vorticella* sp. *indet* (figs. 24, 25, and 26) is a fresh-water animal found attached to immersed leaves. It lives in colonies. Each member presents a bell-shaped body terminating a long and slender stem. It is very sensitive and on the slightest disturbance the bell becomes a sphere by the retraction of the rim shown half completed in figure 25, and the stem is spirally coiled, thus withdrawing the body quickly from the place of danger. The normal condition of things is shown in figure 24. At such times the contractile thread can be seen running up the stem. The body is partly closed at the end but furnished with a groove which leads into a deeper cup, the œsophagus. The rim is furnished with strong cilia and the œsophagus is lined with the same. Food is moved by them to the bottom of the œsophagus, where it is engulfed. The nucleus is a curved rod. Reproduction is by division. Figure 26 represents the act of conjugation in *Vorticella*. In this case a smaller vorticella is produced by division which acquires a circle of cilia around the base. It then swims freely through the water and meeting a second *Vorticella* attaches itself and becomes gradually absorbed so as to finally entirely disappear. This act of conjugation is of great importance, for it seems, from various observations, probable that by it the powers of division are reinvigorated, powers which would otherwise flag and ultimately result in death of the organism.

*Pyxicola affinis* (fig. 23) is like *Vorticella* and *Stentor* a ciliated animal with the cilia terminal, but the body inhabits a chit-

inous cover, which is distinct from the body of the animal. In addition to this safeguard the creature further has attached to itself a cover for the cup, which closes the opening when the body is retracted. These various genera just mentioned form the order CILIATA, and we have now surveyed two classes and three orders of Protozoa.

*Gregarina gigantea* (figs. 13, 14, and 15). The Protozoa thus far mentioned are none of them true parasites, though many live under circumstances which are biologically much the same. But *Gregarina* lives as a true parasite in the body cavity of the earth worm and other invertebrates. It is an elongate, protoplasmic body with fixed outline but no cilia, flagella, or other locomotor processes. There is a portion of the body at one end marked off from the remainder by a slight constriction, but it is not a separate organ. There is a single round nucleus. *Gregarina* reproduces by spore formation (see fig. 15) as well as by division.

Having now outlined a few of the genera of the PROTOZOA, our second consideration is that of the group from the biological standpoint. Do the various PROTOZOA among themselves as a phylum permit us to understand them all as a genetic series, or a series of animals related by ties of kinship? In order to survey the phylum at a single glance I have prepared this table, in which the lines of relationship are indicated by reading across the page.

<i>Phylum.</i>	<i>Class.</i>	<i>Order.</i>	<i>Genus.</i>
Protozoa.....	RHIZOPODA .....	FORAMINIFERA.....	{ SPIROLINA. RODALIA. GROMIA. LIEBERKÜHNIA.
		LOBOSA .....	{ HYALOSPHEMIA. DIFFLUGIA. AMEBA.
	SPOROZOA .....	HELIOZOA.....	{ ACTINOSPHERIUM. CLATHRULINA.
		RADIOLARIA.	GREGARINA.
	INFUSORIA.....	CILIATA .....	{ PÝXICOLA. VORTICELLA. STENTOR. PARAMECIUM.
		FLAGELLATA.....	{ CODOSIGA. NOCTILUCA. PERIDINIUM.

A glance at this table in connection with the facts already presented will show that it is possible to conceive of the Protozoa as a genetic series without doing violence to the facts; in fact when they are taken in connection with a full knowledge of the case, of which only a very incomplete synopsis has been presented, no other conception is rational.

Let us suppose the case of an animal like amœba under favorable conditions. We should expect it to grow and thrive abundantly but subject to competition by very force of numbers of its own kind. With our present knowledge of biology we should

expect the descendants to spread as far from the starting point and into as great a variety of conditions as would be consistent with well-being. A separation would thus result and various descendants would be considerably sundered. We know by many experimental studies in bacteriology, for instance, that lowly organisms can change their characters in response to changed conditions; can acquire the power to live at ease where their ancestors could not have lived. The limits in which this is possible are uncertain. It is conceivable on biological principles that all the protozoa are descended from some single ancestral forms having started in the remote past. This notion is the working hypothesis used to-day by every working biologist. Some forms, we may say perhaps *Amæba*, coming under new conditions of competition with carnivorous foes survived because of the protection it secured by a stony covering, and *Diffugia*, a new genus, survives till to-day, descended from this stock. Other *Amæbæ* found power in the body to make its own covering, and *Hyalsophenia* and *Clathrulina* are the modern descendants of these. Still other *Amæbæ*, we may suppose, specialized the pseudopodia as organs for collecting food and in connection, for protection and support, specialized skeletons of lime or horn. These formed starting points for new lines of development, and the operations within these causes of divergence are conceived as having formed species and later, as these grew more numerous and diverged among themselves, genera; so on into wider and wider groups. In these developments some lines of descent would retain the primitive peculiarities much more strikingly than others. The Lobosa are such an order, while of the Heliozoa and Radiolaria, which appear related, the former seem more primitive than the latter. As a class the RHIZOPODA are more primitive than the INFUSORIA, for the latter have far more peculiar and highly differentiated structure. But the Infusoria can still be conceived of as more highly developed descendants of an amæboid form in which the pseudopodia are specialized locomotor organs, and the body is fixed in outline.

In the same way the orders and genera of the class Infusoria can be understood as descended from certain central points, the ancestral direct line being nearly represented by forms well known but not indicated in our synopsis. *Paramecium* is far more primitive than *Stentor*, and *Stentor* than *Vorticella* and *Pxicolca*. It thus far appears that we can think of the phylum as a great natural group and, if it is so, that a great deal of interesting work presents itself to him who would attempt to unravel the genealogy. This is the problem of modern biology, and full of fascination it proves to be to all who seek its solution, as many have done, with some indications that a solution is not very far distant.

It would be interesting now to consider the mechanism of evolution, but space will not permit and we must turn to the question whether the facts of classification can be interpreted upon

any other hypothesis than that of genetic affinity. Why should all these animals be made of protoplasm? Why should all have similar powers and structure? Why should all have but one nucleus? Why should we find pseudopodia, flagella, or cilia, and these similar and comparable structures? If we regard them of kin, then we can refer these cases to the general law of heredity. No other rational explanation of the classification of animals has ever been conceived. One suggestion was made by Prof. Louis Agassiz in his essay on classification. It was that classification, by which term I mean the sum of facts of resemblance and dissimilarity in animals, was due to the fact, assumed by him, that animals were each species separately created by a being, who, like an architect, had certain plans in mind and made animals on those plans. But the study of classification receives no light upon any such hypothesis, the facts do not lead toward such a conception; for that individuality so conspicuous in an architect's productions is wanting, and the species shade into one another by the most insensible and indefinable gradations. No more convincing proof that the facts do not lead towards Professor Agassiz's theory can be found than the fact that the theory lives merely as a matter of history, a curiosity of speculation, while the genetic hypothesis bears such a stamp of genuineness that it has been universally adopted by the scientific world.

If the evolution hypothesis be adopted the differences among the Protozoa at once become comparatively intelligible as specializations of different protoplasmic activities. In fact the same would probably be held by an adherent of the special-creation hypothesis. The phylum as a whole is thus an assemblage of different organisms, animal in nature, in which the single cell now becomes subordinated in any considerable degree, if at all, to an aggregate of cells. All the higher phyla above the Protozoa are made up of animals which begin life, to be sure, as single cells, but in which these single cells or ova must develop into large colonies of interdependent cells and form an organism. In the Protozoa the specializations of protoplasmic powers produce variety of kind; in the Metazoa the specializations of cell powers produce variety of tissue, as we have already seen in the frog. The Protozoa as a phylum, then, is marked by the lack of any tendency among the cells to co-operate. In consequence large compact bodies cannot be built up, a great variety of station cannot be occupied, and the limits of life are perforce narrow. Two main lines of specialization are at once manifest in the Protozoa—the high specialization of the metabolic function on the one hand and the high specialization of the sensory and motor function on the other are notable in the two large classes, Rhizopoda and Infusoria. In the former the production of a skeleton is the outcome of the operation of the metabolic function. This power would arrive at the production of a membranous-supporting structure first, because its chemical nature is less unlike that of the proto-

plasm itself which the metabolic function is constantly exerted to make, and such forms as *Hyalosphenia* and others would, on this ground as well as others, have to be considered more primitive. The production of a skeleton would make movement unnecessary and perhaps inconvenient, and hence the pseudopodia would be more likely to be specialized as food collectors than as organs of locomotion in Protozoa with a skeleton, and such we find them in the Rhizopoda. The specialization of the metabolic power in secreting a skeleton could not take place on a large number of conceivable lines, the commonest stony material being more likely to be used, and the lighter and stronger ones; in point of fact, only two minerals are used in skeleton-building, namely, lime and silica. We suppose that the secretion of lime in *Rotalia* and its deposition in the body is as definite an act as the movement of a flagellum, and that it is as subject to the laws of improvement by exercise, heredity, etc. The secretion of a membranous skeleton takes place in both the Foraminifera and the Heliozoa, but the more highly specialized members of the orders have a skeleton of lime on the one hand or silica on the other.

Specialization of motility, on the other hand, would make a protective skeleton less necessary, and the specialization of a definite mouth and the loss of the food-gathering function of pseudopodia would put a premium on motion, for an active animal would have more chances of finding food. With activity constant, stimulation would result and thus the possibility of heightened sensitiveness or improved power of sensation would come. The uses of the pseudopodia as flagella or cilia are also cases of varied development of powers, and the varieties of ciliation are cases of the same principle. When the Protozoa are fully understood it is hoped that we can indicate the steps of development which have led up from a shapeless and indefinite lump of protoplasm to the exceedingly complete and perfect organization of Vorticella. It is very interesting to find that some of the Infusoria, *e. g.*, *Pyxicola*, have a sort of skeleton and that it is membranous, the lowest kind of skeleton. The advantages of combination are only slightly secured by the PROTOZOA, if at all. But it is very interesting to find colonies of members in this group, because of the immense importance of cell combination in body construction in higher phyla. Here, as so often, we find an example of a sort of prophetic anticipation in lower groups of the conditions which are fundamental in higher groups. In *Codosiga* the mechanical union of the cells is difficult to explain in terms of advantage.

While two classes thus result from specializations in metabolic or motor powers, a third in which these are at a minimum is possible, provided the need of their exercise is removed, and in a parasitic existence such need would be gone.

The sporozoa are such a class. No one has ever dared to state a conviction whether the sporozoa are probable degenerate descendants from Rhizopoda or Infusoria, but they are generally understood to be from the same ancestry as one or other of these.

In surveying the Protozoa in this way one cannot escape noting the parallel between the phylum, as a whole, and the single bodies of the Metazoa. In any of the higher animals the single egg gives rise to a vast number of cells, some of which specialize the metabolic power, while others specialize motor and still other sensory functions. So in the Protozoa, in its history as a phylum, the descendants of the ancestral form have diverged in consequence of specializations, but in the cells of a higher animal a union and subordination and division of labor makes a body of many parts possible, while in the Protozoa the cells constantly sunder and scatter.

It is a question whether the Protozoa are still undergoing evolution, and in answer it must be said that no conclusive evidence has been adduced. In the absence of proof it must be noted that the older a group is the less liable its members would appear to be to change, for the same reason that conservatism is always characteristic of old age, viz., the law of habit. And yet while this would argue against the probability of change most, if not all, biologists are inclined to admit that changes in structure can take place at any time and become the beginning of a new line of evolution, whether they be changes born in a body which all admit are likely to be transmitted, or acquired variations which all biologists do not consider transmissible. The cultivation of bacteria and the alteration of their powers is a field of investigation bordering on this ground, and the latest researches seem to indicate that among bacteria at least there are few fixed specific boundaries.

EXPLANATION OF PLATE.

FIG. 1. *Amœba proteus*; 2. *A. radiosa*; 3. *A. villosa*; 4. *A. polypodia* in act of division; 5. *Diffflugia pyriformis*; 6. *Hyalosphenia cuneata*; 7. *Actinospherium eichornii*; 8. *Clathrorulina elegans*; 9. *Rotalia* sp.; 10. *Spirolina* sp.; 11. *Gromia oviformis*; 12. *Lieberkuhnia*; 13. *Gregarina gigantea*; 14. *Gregarina flattarum*; 15. *Monocystis agilis*, spore

formation; 16. *Peridinium uberrimum*; 17. *Noctiluca miliaris*; 18, 19, 20. *Codosiga umbellata*, colony, single cell and cell division; 21. *Paramecium aurelia*; 22. *Stentor*; 23. *Pyxicola affinis*; 24, 25, 26. *Vorticella* sp. expanded and retracted, and series showing absorption of conjugate.

## A Bacteriological Potato-Section Cutter.

By CHARLES F. DAWSON, M. D.,

WASHINGTON, D. C.

Several methods of preparing potatoes for a culture medium are now in vogue, each having more or less efficiency, and a variable amount of labor.

One of the most common methods is the use of a large cork-borer, or apple-corer, to cut a cylinder from the potato. This cylinder of potato is divided diagonally, thus making two preparations. Pieces of glass tubing are inserted into the thick ends of the two pieces of potato, and they are placed into ordinary test-tubes and sterilized. The pieces of glass tubing serve to support the potatoes above the level of the condensation water, which always settles into the bottom of the tube. In some instances, specially made culture tubes having a constriction near the bot-

tom of the tube are used. The constriction supports the potato, and the condensation water falls into the reservoir thus formed in the bottom of the culture-tube.

If the potato medium is to be kept for some time, we find that there is a great change in the form of the potato, due to evaporation of water from it. The inoculation surface becomes irregularly concave, the thin end becomes dry, and curls, and the preparation presents an unsightly appearance.

When the potato cultures are to be used for exhibition purposes, it is desirable to have them present a neat appearance. The aim of the writer is to describe an apparatus which he has devised to prevent the changes in form referred to.

The apparatus consists of two pieces: a plugger, represented by figure 1, and a curved knife, represented by figure 2.

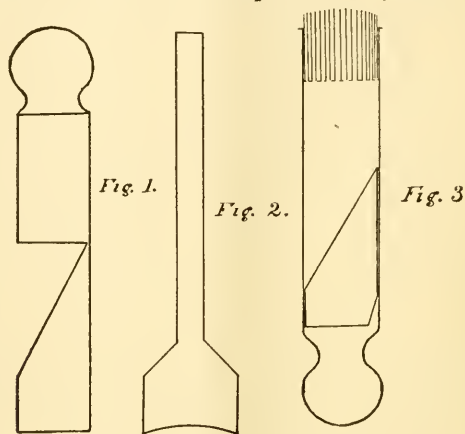

The plugger is made from a metal tube about six inches long, and of a diameter a little less than the culture-tubes to be used. The side of the metal tube is cut out by sawing slantingly through the wall and across the inner diameter of the tube to the opposite wall at such an angle that the distance traversed by the saw will be about two inches, and then by sawing vertically across the diameter of the tube to the wall of the opposite side. The end of the tube nearest the side opening is sharpened from the outer surface, and a wooden handle is fitted into the other end.

The curved knife (fig. 2) is used to cut a convex surface on the potato section so as to compensate for the loss by shrinkage from evaporation. After a time this convex surface will become nearly flat, whereas, if the surface were cut flat at the outset, it would now be irregularly concave.

This knife is made by cutting out a segment of a circular tube of about one and one-half inches in diameter, the segment having continuous with it a narrow portion of the wall of the same tube,



which portion serves as a handle. The segmental portion is sharpened upon its convex surface.

When it is desired to make a potato preparation, both ends of a large potato are cut off, and the plugger is passed through it by a rotary vertical movement. The potato cylinder, which appears in the plugger, should be long enough to reach a short distance into the hollow handle, so that it will be held firmly. By passing the curved knife into the potato cylinder and across its diameter in contact with the sides of the opening in the plugger, the cylinder is divided. The outer piece of the divided cylinder will fall out, and the piece which remains in the plugger now has a beveled surface for inoculation, and it can be removed by pushing it up a short distance into the hollow handle of the plugger.

The thin end of the section should be trimmed off for the distance of about half an inch to prevent its curling, and a notch should be made in the side of the end of the cylindrical portion of the section to admit the passage of moisture from the water reservoir of the culture-tube to the potato chamber above it.

Figure 3 represents the potato section placed in a reservoir-tube ready for use.

---

## BACTERIOLOGY.

---

### What Has Been Done in Bacteriology in Relation to Hygiene.\*

Bacteriology is a new science (*Bacillus tuberculosis* was not discovered until 1881), and considering the short time devoted to its study it is surprising to see how much has been accomplished. Complicated apparatus has been devised, books have been published in many languages, new methods in photography have been invented, and results have been recorded with an accuracy and system that are very gratifying. If the germ theory of disease is the true one, then any research which broadens our knowledge of bacteria must be ranked as in the highest degree humanitarian; and if through these researches we shall come to a better knowledge of disease and how to combat it, not only will the truth of the theory be demonstrated, but the world will confess that the microscope has a practical value greater than that of a scientific toy.

The bacteriologist must be able to determine in regard to a family's or city's water supply, its richness in bacteria, and whether the germs contained are harmful to health. All water, even distilled water, and that which has passed through an ordinary charcoal filter, contains germs. Only by the severe tests of the bacteriological laboratory can we say positively whether a given water supply is contaminated by sewage, and whether the filter used for its purification is effective in removing germs.

The speaker gave a complete description of the methods pur-

---

\* From a paper read at the San Francisco Microscopical Society.

sued in making artificial cultures of different disease germs, and exhibited various colonies in different degrees of development. A suitable medium for the rapid growth of these colonies is found in a preparation of meat juice and gelatine; another in bouillon and agar (a product of an Indian sea weed, *Gelidium spiniforme*). To either of these is added a certain percentage of peptone and, for some purposes, glycerine. It was shown what precautions were necessary to prevent the introduction of foreign germs from the air; how every article used had to be completely sterilized before the germ sought to be cultivated was introduced. The tubes are then placed in an oven which has an automatic regulator of the heat, and kept at a perfectly uniform temperature for such time as may be necessary for the development of the germs.

Some bacteria make gelatine fluid; some grow in the presence, others in the absence of air; some require acid, others alkaline media; some grow only in the presence of glycerine or sugar. There are differences in the color, in the manner of the formation of colonies, in the microscopic appearances and in the effects when thrown into the system as shown in the lower animals. It is by taking advantage of these and other peculiarities that we are enabled to make the differentiating or qualitative bacteriological analysis.

Among the bacteria which have been most carefully worked out, and which are most dangerous to mankind, the speaker mentioned the bacillus of anthrax, the bacillus of typhoid fever, and the spirillum of Asiatic cholera. It is possible for all these to be carried in the water supply. It may be asked, if there can be so many germs in water, why are not all affected? The answer is easy. Many of the germs are entirely innocent, just as many plants are. Of the remainder, many are destroyed by the various processes of digestion.

The special apparatus and the methods of procedure for the examination of germs in air, in earth and in food meat were fully described and commented on. The bacteriologist, by means of the knowledge at his command, is in a position to settle certain questions of public hygiene which are practically guesswork without his aid. A case was recently reported by Dr. Munn, of Denver, where pleuro-pneumonia and tuberculosis occurring in cows had been passed by officials in Kansas City who were not bacteriologists. In Berlin this inspection of meat by bacteriological methods is so strictly carried out that no diseased cows are now presented for slaughter, and one can buy meat in the shops and be sure he is not taking in tuberculosis at the same time.

In nothing, perhaps, can bacteriology be of such practical value to a community as in the investigation and regulation of water supplies. As a city, San Francisco is blessed with a naturally good supply. All through our State are wells, each supplying water to one or more families, but contaminated by sewage and

causing more or less disease. Public attention must first be called to the facility with which such water is infected and its dangers; but eventually we can expect boards of health, composed at least in part of men trained in bacteriology, and whose business it shall be, by its aid, to limit the spread of disease and so add to the sum of human existence.

---

### \* MICROSCOPICAL SOCIETIES.

---

#### ST. LOUIS CLUB OF MICROSCOPISTS.

*September 1, 1892.*—The regular monthly meeting was held at the residence of Dr. H. M. Whelpley, there being an unusually large attendance.

Mr. Harry Stark reported briefly some experiments he is making in devising a serviceable and cheap camera for microphotography. He promised to explain the device more fully and present a finished instrument at the October meeting.

Dr. H. M. Whelpley exhibited and illustrated the use of many of his large variety of microscope accessories, all of which was of absorbing interest to the members.

E. E. Schlueter made application for membership.

The treasurer, Dr. Whelpley, reported on the condition of the treasury, which showed that the club's finances are in exceptionally good condition.

After adjournment Dr. and Mrs. Whelpley held an informal reception in the parlors of their handsome new residence. The doctor and his young bride entertained the members right royally, the fair hostess, by her charming manners, making all wish that every meeting of the club could be held under such pleasant conditions.

#### LINCOLN MICROSCOPIC CLUB, LINCOLN, NEB.—ROSCOE POUND, *Secretary.*

*August 30, 1892.*—The time was spent discussing methods and examining slides exhibited by members. Mr. Woods made glycerine jelly mounts in less than three minutes each—sealed and complete. He used a slight ring of Brown's rubber cement to support the cover-glass. Dr. Bessey exhibited vast fibres from some species of *Sporobolus*. These fibres can easily be isolated with potash in a very short time and better results can be had than by incineration with the plants generally used.

*September 27, 1892.*—The matter of programme and order of exercises was discussed and a new plan reported, which will be passed upon at the next meeting.

Dr. Bessey exhibited a mould growing on a cherry leaf, under a Lieberkuhn, showing it as one might see it by looking along the

surface of the leaf. He explained the cases in which that instrument may be employed to some advantage.

Mr. Marsland exhibited an improved moist chamber made of zinc.

Mr. Dales showed his "home-made" lighting apparatus, consisting of an iris diaphragm in a hard-rubber substage which could be swung out of the way if he wished to change the condenser.

Mr. Woods exhibited specimens of chara collected in the sand hills and thrown into a weak solution of glycerine in which a little carbolic acid had been dissolved. In this way they had been preserved in a very good condition a long time. He used but one or two per cent. solution of carbolic acid.

---

### NEW PUBLICATIONS.

---

*Catalogue of Photographic Lenses.* The Bausch & Lomb Optical Co., Rochester and New York city.

Like this firm's catalogue of microscopes and objectives, this list is a work of art, a beautiful specimen of what an intelligent printer can do with the types when he tries and when he has the help of the paper-maker. The contents, too, will charm the photographer, for the catalogue describes not only the best of the firm's own lenses, with those of Clark, the celebrated manufacturer of telescopes, but it introduces an entirely new series, the Zeiss anastigmat lenses, made from the new Jena glass after formulæ worked out by Prof. Abbe, with whose work all microscopists are familiar. These new photographic productions, for which Bausch and Lomb hold the patent for this country, seem to have valuable qualities.

*Drs. Bourneville and Bricon's Manual of Hypodermic Medication.* Edited by G. A. Stockwell, M. D. Square 16mo, pp. 158. Detroit: Geo. S. Davis. Price 25 and 50 cents.

This is the most valuable number of the Physician's Leisure Library Series that has been issued for a long time. It is so important that every practising physician should have a copy within his reach or on his desk for repeated consultation. It is full of suggestions that must bear fruit for the thoughtful man, and full, too, of warnings that must be as valuable. We have seldom seen a little manual that has so pleased us, or one that can be so conscientiously commended to the medical student and to the advanced practitioner. The price, too, is so low that every physician can afford to buy it, as he may do with safety and with the certainty of being pleased and instructed and helped.



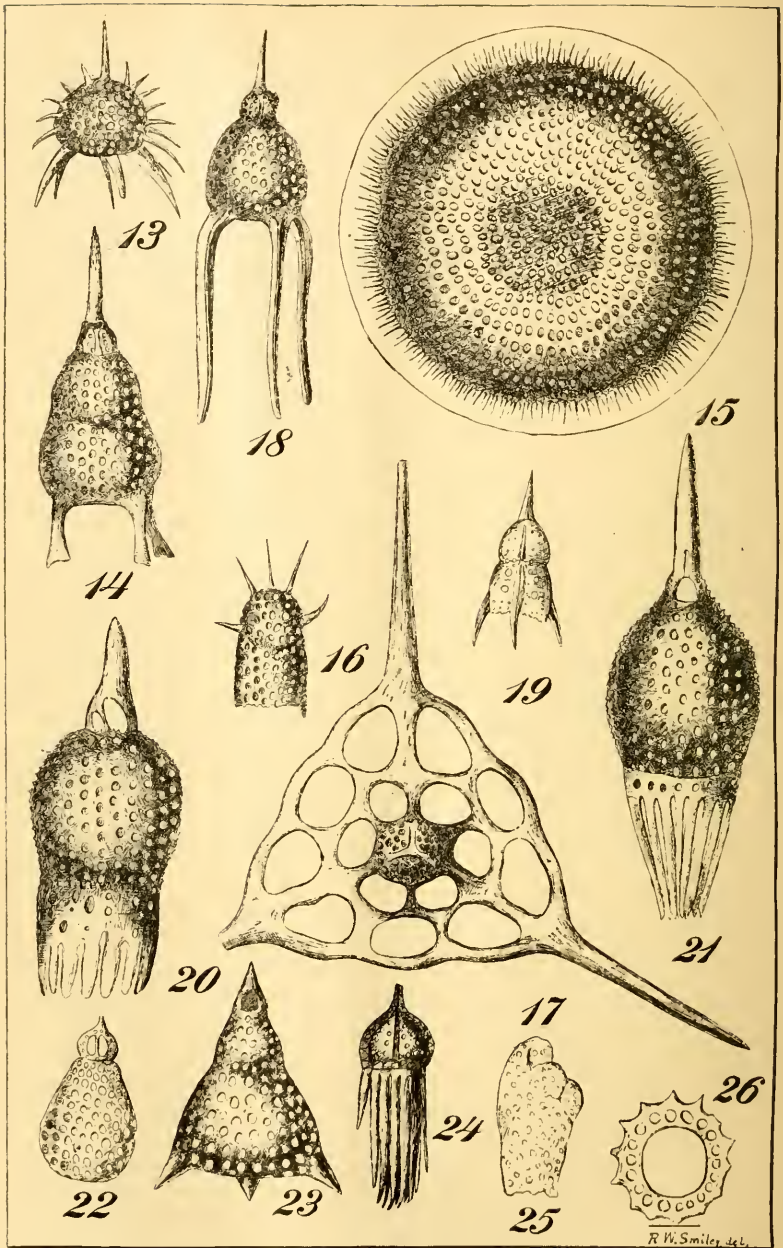

RADIOLARIA.

# THE AMERICAN

MONTHLY

## MICROSCOPICAL JOURNAL.

VOL. XIII.

NOVEMBER, 1892.

No. 11.

### CONTENTS.

Diatomology.—CUNNINGHAM - 249	BACTERIOLOGY. — Bacterioida
Diatoms of the Connecticut	Forms in Tissues and Eggs of
Shore.—III.—TERRY - - - 253	Insects. — Decolorizing
Radiolaria: Their Life-History	Bacillus Obtained from
and Their Classification (Illus-	Sputum.—Bacteriosis of the
trated).—CARTER - - - - 257	Grape-vine - - - - - 267
The Analyzing Eye-Piece (Illus-	MICROSCOPICAL SOCIETIES.—
trated).—LIGHTON - - - - 260	San Francisco, Cal - - - - 268
The Practical Use of the Micro-	NEW PUBLICATIONS. —The
scope in Pharmacy.—DOHME 262	Pharmacology of the Newer
MICROSCOPICAL APPARATUS.—	Materia Medica. Davis - - 272
Substitute for Glass for Covers	
and Slides for the Microscope 267	

### DIATOMOLOGY.

By K. M. CUNNINGHAM,

MOBILE, ALA.

All science may be said to be both evolutionary and progressive, partaking somewhat of the nature of organized beings; passing from the simple relation to the complex in structure on wards without limit. This corollary is preliminary to an exposition of its application to the science of the study of the Diatomaceæ. As far as the writer's experience has gone, one branch of science, classed under botany and pursued almost exclusively with the use of the microscope, has not had its aggregate field of work crystallized under the distinctive title of a science, but has mostly been designated by some subordinate term. My object is to show, or point out, the justice of grouping together all the allied and auxiliary researches and methods of study of the Diatomaceæ under the title of "diatomology," which in its broader definition would mean to comprise all that appertains to the study of diatoms in whatever manner undertaken. Therefore, accumulated experience suggests that the Diatomaceæ can become the basis of one of the most impressive, instructive, and engaging

branches of pure science that may occupy the attention of the human mind.

Firstly, on account of its power in gratifying the purely natural impulse inherent in the mind to be impressed with whatever is beautiful in nature.

Secondly, from its being a legitimate line of research, independent of the merely beautiful, practical, or pecuniary, as science in general takes equal cognizance of the ugly, horrid, or beautiful; but many minds of a scientific turn refuse to become interested in things not beautiful; this is why the devotion to the study of the diatom never surfeits or becomes irksome; hence, with some show of truth, we might paraphrase a popular saying, "Once a diatomist, always a diatomist."

Thirdly, the study of the Diatomaceæ from merely an observational point of view, whether in relation to their place in nature, what role their creation was intended to fill in the economy of nature or of earth-building, and their biological functions in life, is capable of drawing forth the highest and best efforts of mental genius, erudition, and the power of the judicial and critical qualities in bright minds, in dealing with the numerous problems suggested by repeated and lengthy association with their investigation. A field of human effort is here offered well worthy of capable minds, whose deductions may be grand enough to stand as a trinity with the genius that points out the position of invisible perturbing planets in space, or those whose decisions go on record as the final and unalterable disposition of questions as between right and wrong.

The latter two fields of genius appear to be the conceded attributes of many minds, the outcome of the total evolution of all past advances made in erudition and civilization. Why, then, should there not be a third character of talent, equal to the former two, to deal with the co-ordinate problems of geology, palæontology, and biology? These latter three sciences are invariably invaded or trended upon by the diatomist, even though he may have but the fame of an amateur. The above outline brings us to the scope of action of the diatomist. His field of operations is catered to by and is coextensive with the entire physical globe, and in its atmosphere, as well as in its ocean depths, the rocky strata composing its crust, penetrated for thousands of feet, is within his horizon. When one looks back retrospectively on the colossal and lengthy labors of Ehrenberg, condensed in his "Mikrogeologie" (1856), utilizing therein nearly every possible means within the reach of man to bring to light what he could, those who now live can look with deep admiration on this genius of the past, who proved thus early the comprehensiveness of this branch of science; but the later and more recent activity in this line of research has enormously increased our knowledge of the occurrence and distribution of the Diatomaceæ in the liquid and solid component elements of the earth. To appreciate the available resources



within reach of the diatomist it is only necessary to peruse the trade catalogues of two of the leading European commercial *preparateurs*. In these we have a tabulation, both by mineral family groups and by their geographical distribution, showing varieties of material derived from localities nearly as widely separated as from North pole to South pole, from tropical America to tropical Africa; but these lists suggest little of their geological association. We have them from summits and slopes of mountains thousands of feet in height; from the oceans thousands of fathoms in depth; from bituminous strata, marly strata, peat strata; from intra and post glacial strata; from subplutonic strata; from lignite strata; from American Miocene clay strata, penetrated for a thousand feet in depth; from drifted specimens from Pacific Ocean bottom stranded on its west coast; from vast stratified areas in Mississippi and Alabama; from the rocky strata of the islands of the Atlantic and Pacific Oceans; from vast beds of extinct lacustrine areas; from subpeat areas; from the muds and humus of swamps, marshes, creeks, bayous, rivers, bays, and seas, and from the ooze of ocean depths; from saline and thermal springs, and from the aquatic flora of all waters; again, inclosed in altered and petrified strata; from strata in New Zealand altered and metamorphosed by intrusive igneous action or by volcanic action; from the guano islands of the South Pacific Ocean, and inland pelagic desert plateaus of Chili and Peru; from the extinct lake deposits of the Southern river drift or Diluvium period, and the Tertiary sedimentary rocks of the Mexican Gulf coast of the United States; with recurring announcements of the finding of new deposits; thus continually furnishing material for unceasing interest in their study. But, perhaps, diatomology will never complete its ideal cycle until, in addition to the listing and naming of new species and noting localities of occurrence, the geological relations of the deposits as to period, association, and sequence of strata, as well as a comparative study of deposit contents, shall be worked out by the larger methods of the geologist as applied to all other rock formations, aided by graphic and pictorial illustrations of the strata and characteristic natural scenery *in situ*, together with a discussion of the attendant phenomena of deposition, with the speculative deductions and inferences to be derived therefrom, the economic relations and value of these deposits to the arts, and all these data digested, correlated, and generalized, shall the full capabilities, impressiveness, and grandeur of this entrancing science be put upon the pedestal destined for it in the arcana of nature.

We have so far but scattered, imperfect, and disconnected gleams of the store of treasures yet to be segregated in the future into one grand whole for the intellectual gratification of posterity's millions. Diatomology comprises within its fold an army of independent investigators whose efforts are largely absorbed in working out and elucidating the many-sidedness of the science:

to some the main interest is directed to solving the biological character, or life cycle, to settle definitively its plant or animal nature; to others to analyze and make clear the delusive and unsettled structural characters of the inert frustule or shell; to others the interest is largely commercial, forcing their admiration and enjoyment by the beauty and attractiveness of their artistic arrangement in symmetrical arranged groups and designs and type-plates; others by a desire to complete and possess an exhaustive collection of all known species; others by their incidental and characteristic importance in forming geological strata, past and present; others in the skilful reproduction of them as microphotographic records; others in their nomenclature and classification; others in pressing the discovery of new material or deposits and distribution of same, while many labor with an immediate or remote hope that it may fall to their fortune to establish a new genus or to name and describe a new species; others test their skill in improving or altering the classificatory tables, revising and altering the families, genera, and species, as new lights dawn. Diatomology is in its nature the most catholic and universal science extant, as its pursuit binds together by the sympathetic bonds of reciprocity and community of action every locality on the globe where science is cultivated or the microscope is known and utilized; it converges and focalizes to a central objective point innumerable lines or activity, forever feeding the flame of interest by constantly presenting some new addition in one branch or another. to gratify a laudable curiosity and to convey a gentle and pleasing stimulus to the mind. So let us have a science to be known as "Diatomology." It would be comparatively easy to tabulate a list or names luminous with distinctions and laurels won in pressing the study and perfection of the various subdivisions of this comprehensive field of scientific effort as previously alluded to, but they are, no doubt, familiar to all who may peruse this essay. The comparatively recent publication of Wolle's *Diatomaceæ* of North America removes the main obstacle heretofore existing to the rapid advancement and expansion of this all-permeating and fascinating study, to this extent at least, as it is within the reach of every one, and furnishes a ready means for the tyro or beginner to launch out at once into the world of diatoms and wing his way through its empyrean.

The writer asks the indulgence of his readers, and justifies the plea made herein, based on long experience in this branch of microscopic science, having had the fortunate experience of putting on record for the initial time the occurrence of one fresh-water fossil diatomaceous deposit, two marine fossil deposits, one fluviatile marine deposit, and several deposits of lesser importance, and dissemination of the material, in the fifteenth year of his experience in this science; and having personally handled the leading fossil earths from every well-known locality, and having also examined and consulted all known accessible litera-

ture dealing with the Diatomaceæ, as well as having made and put upon record the largest single selected slide of diatoms from a local circumscribed area, the same studied with a 1-15 homogeneous oil immersion lens of 1.25 N. A. in detail, as well as microphotographed for permanent record, the slide being the largest that has come under my notice, although larger and better slides have been made by others, yet on a dissimilar plan, and of course of greater perfection, merit, artistic skill, and scientific value.

To note additional devotion to the study, I may relate that I have printed with pen and ink, in neat and legible italic letters, the specific names of the 2,300 figures in my copy of Wolle's N. A. Diatomaceæ, contiguous to each species, which makes the book doubly useful, as a glance at any plate dispenses with the use of the numerical tables of species on the opposite pages.

Finally, in treating of this science we must not overlook the marvelous searching analysis of the diatomist, in the study and preparation of material of low percentages, whose successful manipulation aggregates, out of unpromising material, millions of the beautiful frustules whose final function is to entrance the eyes under the lenses of high or low power.

---

### Diatoms of the Connecticut Shore.—III.

By W. A. TERRY,

BRISTOL, CONN.

Among the new forms found at Morris Creek, and not mentioned in my former articles, are *Tropidoneis* (*Plagiotropis*) *Zebra*, n. sp., Cl. pl. xii, fig. 1, *Le Diatomiste*; also *Tropidoneis* (*Plagiotropis*) *seriata*, n. sp., Cl. pl. xii, fig. 2, 3, 4, *Le Diatomiste*. This last form is very abundant in many of my gatherings from the salt marshes, as is also *Scoliopleura* (*Scoliotropis*) *latestriata* var. *Amphora*, n. var., Cl. pl. xii, fig. 13, *Le Diatomiste*; other new forms I defer mentioning until printed lists are received.

The rocks near the tide gate at Morris Creek are at some seasons covered with a dense growth of filamentous diatoms, in rounded masses resembling sponges in appearance, and of a light yellowish brown color. The filaments are from two inches in length on the margins to four and six inches at the centre of the masses, and are chiefly *Melosira Borrerii*, entangling many kinds of the independent travellers, including fine specimens of *Pleurosigma Americanum* and *Pl. paradoxum*; and here is a point which I consider worthy of notice. We are told by some writers that all diatom growth starts from a sporangial form, and that in multiplication by division each new valve is appreciably smaller than the old one, and that the great difference in size found between individuals of the same species is a result of repeated subdivision and old age.

Now, in these tufts of *Melosira* the shorter filaments are as much smaller in diameter as they are shorter in length, and they contain about the same number of individual diatoms, and, as would be inferred from this, according to my observations, they all commence growth at the same time; consequently the great difference in size cannot be a result of repeated subdivision.

A small pond in Bristol, Conn., is very rich in diatoms; in one gathering from the upper margin of this pond I found an unusual form of *Pinnularia*. It was nearly the size of *Pinn. major*, but did not separate after division; so that it formed long ribbon-like filaments containing as many as thirty-two and sometimes sixty-four individuals, all apparently of the same size; careful measurements failed to show the slightest difference in size.

In the rapid current just above the tide gate at Morris Creek, growing on stones constantly submerged, but subjected to changes from salt to brackish water at every tide, is a peculiar *Polysiphonia* I have never found elsewhere. The filaments are very fine, about two inches long, of a very dark hair-brown color; immersion in fresh water has little effect upon it. I have kept it for two days in fresh water without any more apparent change than the difference in temperature would cause; this seems remarkable, as other *Polysiphonia* immediately discharge their coloring matter and decay upon being placed in fresh water. This growth extends up the stream into the borders of the *Melosira*, where they grow together.

In the latter part of summer, and particularly in September, the ditches of this section are covered with a floating scum consisting largely of *Algæ* and *oscillaria*, but containing vast numbers of apparently minute diatoms. Last autumn I found the mud at Leete's Island Creek at ebb tide covered with a rich brown coating extending over many square yards of surface; these were also minute diatoms, of *Navicula* shape, going through the characteristic motions with surprising activity.

Last month I found a similar coating on the mud at low tide in a ditch leading from the moat at the rear of Fort Hale, New Haven harbor. These were similar to the others, but contained also large numbers of small *Pleurosigma*, which were, however, many times larger than the forms making up the bulk of the deposit.

These forms I cannot class with any described varieties, and the fact that they contain so little silex as to be completely dissolved by acids causes me to regard them as young diatoms developing from spores. Unfortunately I have been unable to visit the localities in such consecutive order as would be necessary to trace their development in their native habitat, and every attempt at artificial culture has so far failed on account of the rapid multiplication of large ciliata which devour them before they have time to grow. I have not yet discovered any method of freeing a gathering containing them from their devourers, and

do not yet see how it would be possible. A continued exposure to low temperature would probably retard the growth of the animals; whether a point could be found where the diatoms could grow and their enemies could not is uncertain, but the fact of the rapid growth of diatoms in early spring makes it seem probable.

Of the fossil deposit of diatomaceous clay underlying the Morris Creek marshes I have been able to make only a superficial examination, as there has been no excavation except ditches, and it is all under water at high tide. The ditches have brought up clay from about four feet in depth; this contains many of the forms specified in article No. 1, but has abundance of *Navicula* of many varieties; *Amphora* and *Scoliopleura* in variety are also abundant.

Boring for material in these marshes is unsatisfactory for a reason given in a former article—that is, the very unequal distribution of the diatoms; many borings might be made in close vicinity to a rich deposit without finding it. Excavation is the only satisfactory method. This the tidal waters forbid to ordinary explorers, but the railroads cross some of these marshes, and by taking advantage of their work something can be done. The Shore Line railroad has lately been changing its track across some of these marshes to a point nearer the shore, and has brought up the deposit from greater depths than the ditches had previously done. At Leete's Island I find an exceedingly interesting deposit containing many rare and beautiful kinds. The broad channel which once separated Leete's Island from the mainland has been completely filled by a marine deposit, and is now a salt marsh, through the eastern part of which flows Leete's Island Creek. This marine deposit is at least thirty feet thick and is stratified; contiguous strata of an inch or two in thickness contain entirely different forms.

Tropical forms abound; several different strata contain *Isthmia nervosa*, though as I have previously mentioned finding this form in the recent mud of Boston harbor, as well as various places on the Connecticut shore, it might be looked for here. The beautiful *Surirella Febigerii* is a tropical form, but is found along the Connecticut shore. A stratum about seven feet below the surface contains this form in extraordinary abundance, the finest specimens I have ever seen; an average slide containing over fifty; also *Coscinodiscus*, large and small, in profusion; *Rhabdonema Adriaticum*, *Tropidoneis seriata*, *Pleurosigma Balticum*, *Pl. affine*. all in abundance; *Biddulphia*, large and small varieties; *Navicula lyra*, *N. maculata*, *N. Smithii*, *N. permagna*, and numerous smaller varieties; *Amphitetras antediluviana*, *Actinocyclus crassus*, *Auliscus*, *Raphoneis*, *Actinoptychus*, *Scoliopleura*, and numerous others.

*Navicula maculata* is rare; I have found it in noticeable quantity in only one deposit previously; that was sent me from New-

ark, N. J., by Prof. Edwards. In one stratum of this Leete's Island deposit, near the surface, it is so abundant and remarkable as to occur profusely in three different types, which vary in marginal outline as well as in size and peculiarity of striation. With this are also *Surirella striatula*, *Navicula elliptica*, *N. constricta*, *Pinnularia æstuarii*, etc., in abundance. In direct contact with the above stratum is another, in which the chief forms are large *Coscinodiscus*, *Actinoptychus*, *Triceratium favus*, *Eupodiscus Argus*, *Amphitetras*, etc.

About five feet below the surface is a stratum containing abundant *Navicula*, many small varieties, with *Navicula permagna*, *N. maculata*, smaller type, *Pleurosigma Americana*, *Pl. Balticum*, *Pl. affine*, with *Scoliopleura*, *Amphora*, *Raphoneis*, &c.

The stratum containing *S. Febigerii* has also an extraordinary abundance of very minute forms, including many varieties of *Coscinodiscus* and of *Biddulphia*; other strata have only heavy forms, large *Coscinodiscus*, *Actinoptychus*, *Triceratium*, *Aulacodiscus*, *Eupodiscus Argus*, *Stephanopyxis valida*, *Steph. ferox*, etc.

I was unable to explore Leete's Island Creek, as the upper meadows were flooded in consequence of the upheaval and disturbance caused by the pressure of the railroad embankment.

Leete's Island Bay contains a deposit in which large *Coscinodiscus*, *Triceratium*, *Actinoptychus*, *Eupodiscus Argus*, and other heavy forms are most plentiful; it contains also *Pleurosigma decorum* of the same type as that at Morris Cove, but not so abundant. More particular mention is deferred to a subsequent paper.

---

**Human Saliva and Pathogenic Micro-organisms of the Mouth.**—Dr. G. Sanarelli concludes (*Centralbl. f. Bakteriol. u. Parasitenk.*, X, 1892), from a series of experiments, that human saliva is a very unfavorable cultivation medium for certain pathogenic microbes, since it possesses the power of destroying them more or less quickly unless their number be too great; and that although it permits the development of certain species (*Pneumococcus*), it alters their type and renders them weak or even inert.

The saliva was obtained from various healthy individuals, and was then passed through a Chamberland's filter into test-tubes, each having 10–15 ccm. The fluid in these tubes was then inoculated from cultivations of the following micro-organisms: *St. pyogenes aureus*, *St. pyogenes*, *Bact. Diphtheriæ*, *M. tetragenus*, *Pneumococcus*, *B. typhosus*, *cholera spirillum*.

**To Remove Oil and Grease from Whetstones.**—The process consists in stirring up whitening with water and applying it with a brush to the whetstone, which has been warmed in an oven.—*Zeit. f. Wiss. M.*

## Radiolaria: Their Life-History and Their Classification.

BY REV. FRED'K B. CARTER,

MONTCLAIR, N. J.

[Continued from page 219.]

It may be a help to the student to know that there is a great difference between the genera as regards the number of the species in each. Furthermore, there is a difference in the number of species of any genus as regards the special locality in Barbadoes. This is very evident as one studies Ehrenberg's analysis of this material. For the convenience of the student I give the results in two columns, the first being the total number of species of each genus found by Ehrenberg in the Barbadoes deposit; the second the number found at Springfield.

	Total.	Springfield.
<i>Anthocytis</i> , . . . . .	9	8
<i>Astromma</i> , . . . . .	3	1
<i>Calocyclus</i> , . . . . .	2	
<i>Carpocanium</i> , . . . . .	1	
<i>Cenosphaera</i> , . . . . .	3	2
<i>Ceratospyris</i> , . . . . .	18	13
<i>Cladospyris</i> , . . . . .	2	2
<i>Cornutella</i> , . . . . .	9	5
<i>Cryptoprora-Sethampora (H)</i> , . . . . .	1	
<i>Cycladophora</i> , . . . . .	6	5
<i>Dictyocephalus</i> , . . . . .	1	1
<i>Dictyophimus</i> , . . . . .	1	1
<i>Dictyopodium</i> , . . . . .	2	
<i>Dictyospyris</i> , . . . . .	8	6
<i>Eucyrtidium</i> , . . . . .	48	25
<i>Flustrella</i> , . . . . .	3	3
<i>Halicalyptra</i> , . . . . .	3	1
<i>Haliomma</i> , . . . . .	17	13
<i>Histiastrum</i> , . . . . .	2	2
<i>Hymeniastrum</i> , . . . . .	1	1
<i>Lithobotrys</i> , . . . . .	8	1
<i>Lithocampe</i> , . . . . .	2	2
<i>Lithochytris</i> , . . . . .	5	3
<i>Lithocorythium</i> , . . . . .	3	3
<i>Lithocyclia</i> , . . . . .	2	2
<i>Lithomelissa</i> , . . . . .	5	3
<i>Lithopera</i> , . . . . .	4	4
<i>Lithornithium</i> , . . . . .	4	3
<i>Lophophæna</i> , . . . . .	5	4
<i>Lychnocanium</i> , . . . . .	15	9
<i>Perichlamydidium</i> , . . . . .	1	1
<i>Periphæna</i> , . . . . .	1	1
<i>Petalospyris</i> , . . . . .	10	5
<i>Podocytis</i> , . . . . .	31	17

	<i>Total.</i>	<i>Springfield.</i>
<i>Pterocanium</i> , . . . . .	5	3
<i>Pterocodon</i> , . . . . .	3	
<i>Rhopalocanium</i> , . . . . .	1	1
<i>Spongosphæra</i> , . . . . .	2	2
<i>Stephanastrum</i> , . . . . .	1	
<i>Stylocyclia</i> , . . . . .	1	1
<i>Stylodictya</i> , . . . . .	10	7
<i>Stylosphæra</i> , . . . . .	9	9
<i>Thyrsocyrtis</i> , . . . . .	10	4

Total, Barbadoes, 278 Sp'g'd, 174

That is to say, of the 278 forms found by Ehrenberg in the Barbadoes earth only 174 were found in material from *Springfield*, and 6 genera were not found there, namely, *Calocyclus*, *Carpocanium*, *Cryptoprora* (= *Sethampora*) *Dictyopodium*, *Pterocodon*, and *Stephanastrum*. But from another district the material yielded 72 additional species, including representatives of all the 6 genera not found at Springfield. I call especial attention to this, because the mere fact that one has some earth from Barbadoes is no assurance that he will find all the forms mentioned above, or even all the genera. Some of the material was very poor in both genera and species. Thus, that from Bissex Hill yielded him only 5 genera and 7 species, though there are undoubtedly more in that material.

Note, further, that besides these two divisions of the *Radiolaria* there are two others, the spinous skeleton of which are seldom observed, except in the living state.

However, the student will find that these fossil forms will keep him busy for a long time, while the illustrations of the *Acantho metrina* and others, the skeletons of which are so loose that they readily fall apart and are lost, can be seen in Haeckel's work, a copy of which is fortunately at the command of every one living near the Astor Library, New York (vol. 18 of the Challenger Report). If one is enthusiastic and rich (which unfortunately is not often the case) he can procure a copy for himself, through MacMillan, of New York, at the cost of some forty dollars, by no means exorbitant, when you consider that it represents *ten years* of laborious work, but still beyond the reach of most students.

A word or two more about the preparation and mounting of these forms. I have given the simplest method, but if the student becomes interested he will not be satisfied with that. The forms will not be clean enough to suit him. After trying various methods, at the suggestion of a correspondent I tried that used by Terry in cleaning diatoms, and described in a former number of the JOURNAL, only instead of mixing bi-chromate of potash with the material and then adding sulphuric acid, I use chromic acid,



which gives good results and is simpler. Buy the crystals of chromic acid and dissolve in water as you need them. Then take the material which has been partially cleaned by the process I mentioned and put it in an evaporating dish, pouring off as much of the water as possible. Heat the bottle of chromic acid by letting it stand a minute or two in hot water. Heat the material also in the evaporating dish over the spirit lamp. Then add the chromic acid and let it stand a few minutes, keeping up the heat by the spirit lamp. Then pour the material into quite a quantity of water in a high glass and let it settle. Wash until all the yellow color disappears. Then let the material settle in a test-tube, pour off as much of the water as possible and cover with strong ammonia. Then wash several times again. If the forms are not then clean enough repeat the process and keep on repeating till they come out as you wish.

Then, as to mounting, if you want to get a fine effect by dark-ground illumination, incinerate the forms on platinum foil or thin mica over the spirit lamp or Bunsen burner. This will change the forms from a *glassy* to a *milky* white. Mount in balsam and look at them by transparent light. They will appear *black* or *brown*, and seem an utter failure. Ask yourself if it seems possible that they should show up well by dark-ground illumination, and then try it, and you will probably be as much surprised at the result as I was, when by mere chance I made the experiment. The forms with the binocular stand out with wonderful distinctness, and the effect is almost equal to that of an opaque mount. You have only to use dark-ground illumination on a slide of forms that have not been burnt to be convinced of the superiority of this method.

And now, in conclusion, let me say that I am certain there is a vast amount of pleasure in store here for any young microscopist. With many a beginner the question is, what special line to take up. And even many a microscopist of long standing and larger experience is at times at a loss as to what he shall make a subject of close investigation. If any of you are in that state, or ever find yourself in it, casting about for some special line of study, I would advise you by all means to settle on the *Radiolaria*, and work at them thoroughly. First, because they are so easy to prepare, and, secondly, because I know they will amply repay all the labor you may put upon them.

For the illustrations which accompany this article I am again indebted to Mr. Robert W. Smiley, and desire here to express my thanks to him for his kind assistance.

## LIST OF FIGURES IN THE FRONTISPIECE.

- FIG. 13. *Ceratospyris Echinus*.  
 14. *Thyrsocyrtis Rhizodon*.  
 15. *Periphæna decora*.  
 16. *Lophophæna Capito*.  
 17. *Dictyophimus Craticula*.  
 18. *Lychnocanium Tripodium*.  
 19. *Lithomelissa macroptera*.  
 20. *Calocyclus Turris*.

- FIG. 21. *Anthocyrtium (Anthocyrtis) Ficus*.  
 22. *Lithopera Lagena*.  
 23. *Iithocyrtis Tripodium*.  
 24. *Petalospyris Flabellum*.  
 25. *Botryocyrtis (Lithobotris) cribosa?*  
 26. *Stephanolithis (Lithocircus) annularis*.

[THE END.]

## The Analyzing Eye-Piece.

By WILLIAM LIGHTON,

OMAHA, NEBR.

At the first meeting of the American Society of Microscopists, held at Indianapolis, I presented a paper upon an Analyzing Eye-Piece, and exhibited one that I had been using for several years. I sent, at a later date, a drawing and description of it to the San Francisco Microscopical Society. I have had many letters from microscopists since that time asking about the appliance, and I have been strongly urged lately to present the matter through the *American Monthly Microscopical Journal*.

The apparatus consists of a box, *A*, of the form shown in the side view, fig. 1, made of either metal or wood, and containing a plate of polished black glass, *B*. At the lower part of this box is a short tube, *C*, which fits into the draw-tube of the microscope, and at the opposite angle of the box is another short tube, *D*, which receives the eye-piece. The glass plate is used for the purpose of reflecting the beams of polarized light at the best analyzing angle. It will be necessary, of course, to use some form of polarizer below the object upon the stage of the microscope, and the best is the Nicols prism.

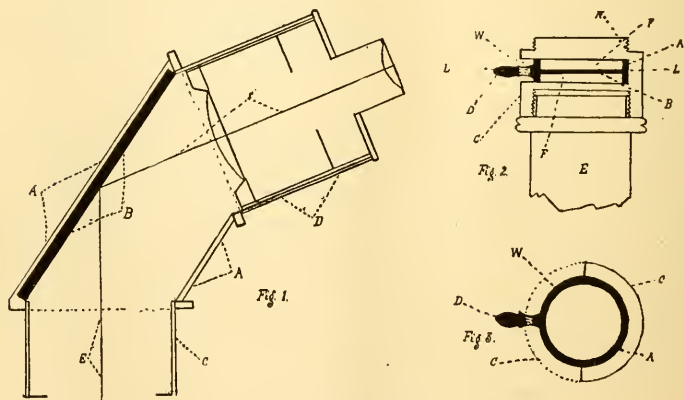

Lighton's Analyzing Eye-piece.

The line *E* represents a ray of light which has been reflected by the concave mirror through the Nicols prism and objective, and is reflected by the polished surface of the glass *B* through the axis of the eye-piece, as shown by the line *F*. *G* represents the eye-piece.

The exact angle of inclination of the polished surface of the

glass to the line  $E$ , which represents the axis of the microscope, is very important.

This angle should be  $146$  degrees, which will cause the reflected beam  $F$  to form an angle of  $112$  degrees with the line  $E$ , which is the correct angle for a reflector of polished German plate-glass, now to be described.

If a piece of black glass cannot be obtained, procure a piece of perfectly polished German plate looking-glass  $2\frac{1}{8}$  inches long and  $1\frac{1}{4}$  inches wide. Scrape off the silvered surface and thoroughly clean. Paint the cleaned surface quite heavily with black paint. Plate-glass of a dark green color, when examined edgewise, is best.

A diaphragm,  $L$ , with opening about the diameter of the field lens of the eye-piece should be placed at the lower end of tube  $C$ .

It is hardly necessary to state that this piece of apparatus is used as an analyzing arrangement instead of the Nicols prism analyzer placed above the objective. The following are some of the valuable features of this arrangement:

It allows the entire angular aperture of all objectives to be used which is not the case when using the Nicols analyzer and large-angle low-power objectives. The stage can be kept in a horizontal position in chemical experiments and in the examination of fluids, and the line of vision for the worker is the very convenient one shown at  $F$ . The image of very delicate objects is free from distortions, which is rarely the case when using a Nicols analyzer.

The analyzing eye-piece can be revolved in the draw-tube of the microscope by means of the tube  $C$ , giving the usual effects of a revolving analyzer.

It is well to use a hemispherical lens of about  $\frac{5}{8}$  of an inch diameter above the selenite film and polarizing prism, with the convex side of the lens toward the object upon the stage, and the upper part of this convex surface about  $\frac{1}{4}$  of an inch from the object.

A modification of the revolving mica film, which I described in "The Omaha Clinic," to be used with the Nicols analyzer, is of special value used with the above-described eye-piece arrangement, and it is represented in figs. 2 and 3.

The apparatus consists of a plate of mica placed between the analyzing plate and the object upon the stage of the microscope, in such a manner that rotation can be given to it, and it can be instantly removed if desired.

Let fig. 2 represent a side sectional view of the apparatus.  $C$  is an adapter carrying the rotating mica plate.  $E$  is the objective screwed into the lower part of the adapter.  $N$  is the screw for the body tube of the microscope. The mica film  $B$  is to be cemented between two plates of perfectly polished glass,  $F$ , of sufficient thickness to prevent distortion of image. This disc is to be fitted in the ring  $A$ , to one side of which is screwed a small handle,  $D$ , to be used in giving rotation to the plates  $B$ ,  $F$ .  $A$

slit, *W*, is cut in the side of the adapter *C* to allow of the necessary motion to the handle *D*. The amount of this motion is governed by the length of the slit.

Fig. 3 is a top sectional view, as indicated by the dotted lines *L L* in fig. 2. The letters in figures 2 and 3 refer to the same parts. It will be seen in fig. 3 that the slit for the rotation of the mica film allows 180 degrees of motion, which is equal in its optical effects to an entire revolution. In selecting mica films great care must be taken to use only those which are free from bubbles, lines, and other optical defects, and are perfectly clear, and the richest effects are obtained when used in connection with a red and green selenite film placed in its position over the polarizing prism, and the mica plate so placed in its plane of rotation to the polariscope that it gives a deep, rich violet color to the field of the microscope. This will be the case if the proper thickness of mica film has been selected.

As before mentioned, it will be noticed that the mica film is placed between the analyzer and the object upon the stage, and in this position it will be found to give new and beautiful effects, in many cases giving great boldness to delicate structure.

### The Practical Use of the Microscope in Pharmacy.\*

BY ALFRED H. DOHME, PH. D.

Nearly every graduate in pharmacy who has taken his degree during the course of the last twenty years has become acquainted with the theories underlying the use of the microscope, and also the results that may be achieved by its use in the hands of a microscopist. I venture to assert, however, that but few of this large number have ever done much practical work with this subtle and valuable instrument, and still fewer have ever made any practical use of the same in their profession.

Medical men have used it more generally for some time past, and since the recent interesting observations and discoveries of our celebrated bacteriologists and histologists all over the scientific world, its use is becoming more general every day, so that the time is not distant when every graduate in medicine will be compelled to be skilled in its use and to use it for diagnostical as well as research work. Pharmacy is keeping pace with her sister sciences of bacteriology, histology, and chemistry, and in this particular branch she must not fall behind, for her advances in the decades to come will be along the line of microscopical work, combined, to be sure, with chemical work. Particularly in these days of close competition in all lines of trade, consequent upon which is the adulteration of the products, natural as well as manufactured, is it incumbent upon every pharmacist to be able to detect the false from the true and the adulterant from the adul-

\* Read before the American Pharmaceutical Association, 1892.

tered. I feel confident that the pharmacist will not shrink from the use of the microscope as an invaluable aid in enabling him to discover whether he is being imposed upon or not, when it is made clear to his mind that the processes involved in this work are very simple, inexpensive, and easily as well as rapidly carried out. If he can be brought to see and appreciate this fact, the time will come when it will be as common to see a microscope in his laboratory as it is to see there his test-tube, flasks, and percolators.

It is not my purpose to enter into details about the mechanism or theory of the microscope, and I will assume that every one is conversant with these. I will hence at once proceed to enumerate what I consider to be the requisites for a microscopical outfit such as will suffice for the examination of any plant, drug, or chemical that may come up for examination in the routine of a pharmacist's career. In the first place, a microscope such as will magnify from thirty to five hundred diameters is essential; then object-glasses 1x3 inches in size, made of ordinary window-glass; cover-slips for the same of very thin glass, as can be bought at a very moderate price from almost any optician or dealer in microscopical supplies—a box of twenty-five of these will last for years; also a razor, which is not an unknown quantity to most men; a few needles inserted in wooden handles to facilitate their manipulation, and a few good-sized corks of good quality. In addition to these are wanted a wash-bottle with distilled water, a watch-glass, and a few drop-bottles containing glycerine, alcohol, and several dye stuffs in solution to be used as staining agents. For the uninitiated—or initiated, too, for that matter—it is advisable, if not necessary, to have a book of plates or drawings of sections of all the various drugs as they appear when viewed through the microscope. Unfortunately there are very few of these extant, due largely to the fact that this branch of pharmacy has so long lain dormant. As we advance, however, and the demand increases, books will soon make their appearance "*en masse*," and among them, I have no doubt, will be found many excellent series of drawings of sections of all drugs, which will enable the pharmacist-microscopist to at once recognize the drug he is examining in section under his microscope.

While working with Prof. Flickiger at Strassburg, I made the acquaintance of an excellent little collection of drawings of sections of drugs as they appear to the eye when seen through the microscope. It is in French, unfortunately, but that does not affect the value of the drawings, which remain the same for all tongues, and is published at Paris by the "Librairie F. Savy, 77 Boulevard Saint Germain," and has as collaborators and editors Professors J. Godfrin and Ch. Noël, of the College of Pharmacy of Nancy. It is entitled "*Atlas Manuel de L'Histologie des Drogues Simples*," which, translated into English, reads, "Manual of the Histology of the Simpler Drugs." Mr. Gerock,

Professor Flückiger's assistant and a most excellent microscopist, first called my attention to the book, and Professor Flückiger himself also heartily indorsed it. The cost of the book is a very modest one, being only six francs (\$1.25). This constitutes the complete outfit of our pharmacist-microscopist, and it is plain that, outside of the microscope, there is little necessary that a pharmacist has not already in his laboratory.

In regard to the staining agents, I shall speak more in detail when I come to the subject of staining the prepared section. Now let us begin our preparation of the section of a given dry drug that comes up for examination, taking, for simplicity's sake, a root or stem to begin with. We place our microscope on the table before us, facing the source of light—usually a window—and get the mirror at the proper angle to give us the best illumination. Our watch-glass is placed to the right of the instrument, and some water poured into it from the wash-bottle. A small piece of the drug, preferably a small, thin root, not more than an inch in length, is then immersed in the water and allowed to remain there until it has become quite soft and well saturated with liquid. While this is soaking, we take a good, sound cork, and with our razor cut it in two through the centre along its longer diameter, being careful to have both cut surfaces smooth. We next take our saturated root and place it between the two pieces of cork, so that it rests between the two flat surfaces of the latter. The upper surface of one of these is lowered below the level of the other, and the top of the root must protrude above the top of the lower piece of cork and below that of the higher piece. It is well to cut off a piece of the root with the razor, prior to cutting sections therefrom, so as to have a fresh surface to cut from when we are ready to begin operations. Having this freshly-cut surface of the root just barely protruding above the surface of the lower piece of cork, all being held together between the thumb and first finger of the left hand, we take the razor in the right hand, and, with the shearing motion, draw the razor across the surface of the root. In this way cut about six or eight very thin sections of the root, all of which will adhere to the razor. Next remove these into the water in the watch-glass, and see if any of them are thin enough for use. (They must be decidedly translucent, if not transparent, in order to be fit for use.) If none of them are thin enough, cut some more until one thin enough is obtained. We next place before us one of the already described object-glasses, and from our wash-bottle drop a drop or two of water upon its surface. With one of the mounted needles we now place our best section or sections upon the drop of water, and then place over this one of our cover-glasses, or cover-slips, as they are generally termed. By slightly pressing upon the surface of the cover-slips with our needle, we now attempt to remove as many as possible, if not all, of the air bubbles that have collected under the same. This can usually be done, especially

by the aid of a small piece of bibulous paper, which, too, serves to remove the excess of water protruding beyond the edge of the cover-slip. A few drops of alcohol dropped upon one of the edges of the latter and drawn through the liquid under the cover-slip by means of a piece of bibulous paper placed on the opposite side very frequently removes the most stubborn air bubble.

Our slide is now ready for examination under the microscope. As the water is very apt to evaporate before the examination is completed, it is well to drop a drop of the same on the edge between the glass and the cover-slip during the course of the examination. Having adjusted the objective of the lowest power, say forty diameters, in place, we set our microscope so that it is facing the source of light, and then adjust the mirror by looking through the ocular at the field until we are convinced that the entire field is most completely illuminated. We now place our slide upon the object-stand and slide the tube up and down until we can see the section fairly accurately. The final focusing is then done by means of the micrometer screw attached to the side of the tube. With an objective that magnifies about forty diameters we usually can see all of the section, provided the latter is not broader than one-quarter of an inch, which it should not be, to be of practical value. After having taken a general view of the section, we turn to our book of plates and see if any of the latter are similar, or very nearly so, to the same. In some cases it is necessary to insert an objective of a higher power and examine certain parts more in detail, and then compare these again with our plate. It may also be necessary, in some cases, where there are many varieties of the same species, as, for instance, the cinchona barks, to make a longitudinal section in order to decide upon the exact variety, as many of the latter are almost, if not exactly, the same in cross-section.

As a rule, we will not have to resort to staining, by staining agents, in order to decide what drug we have in hand, but it is sometime necessary, and always pretty and interesting, to add a few drops of one of our staining agents to fully decide upon certain features of the drug section; for instance, which is cellulose and which is woody fibre, or which is starch and which inuline or crystals of inorganic salts. This is, however, only a refinement and not necessary for the decision of what we are examining. The staining agents most generally used and most decided in their action are the following:

ANILINE SULPHATE.

Distilled water . . . . .	10 ccm.
Sulphuric acid . . . . .	1 drop.
Aniline sulphate . . . . .	0.1 gm.

PHLOROGLUCINE.

Five per cent. solution of phloroglucine in absolute alcohol made acid by concentrated hydrochloric acid.

## EOSINE.

Eosine . . . . .	0.5 gm.
Absolute alcohol . . . . .	50 ccm.
Glycerine . . . . .	50 ccm.

## IODINE SOLUTION.

Iodine . . . . .	1 gm.
Potassium iodide . . . . .	3 gm.
Distilled water . . . . .	60 ccm.

Aniline sulphate is used to distinguish woody fibre from cellulose, as are phloroglucine and eosine, while iodine is used to detect starch. The solutions are to be kept in glass-stoppered drop-bottles, and one drop dropped therefrom upon the edge between the object-glass and cover-slip when used. Aniline sulphate colors the woody fibre cells brownish-yellow, and leaves the cellulose cells uncolored. Phloroglucine, the preferable one of the three, colors the woody fibre cells a lovely pink and leaves the cellulose uncolored. Iodine, of course, as we all know, colors starch a deep purple-violet and does not color inuline or inorganic salts. There are many other staining agents, but the above will answer all purposes, and are usually preferred for botanical microscopy.

At first it will, of course, be necessary to watch and study the plates very closely, making them answer the purpose of an instructor, but soon we will learn by experiences and actual observation the characteristics of most standard drugs, and then be able to decide without reference to our plates. By following the method outlined in this paper there is hardly any doubt that almost every one can recognize drugs microscopically, and with a minimum expenditure of time and money. Besides the advantage gained in determining the drug, there is a fascination in microscopic work that will, I venture to assert, take hold of every one who has any desire at all to enter into it, and repay him amply in the shape of enjoyment, satisfaction, and pride.

In order to facilitate the understanding of those who are unfamiliar with microscopic work, a brief description of the various parts of the plants seen under the microscope may not be out of place. It must be borne in mind that as a rule we have to deal with roots and stems, but that sometimes we are also called upon to examine pollen and fruit of plants, as, for instance, buchu, kamala, and anise, respectively.

For leaves and fruits, as for roots and stems, we usually take only cross-sections for examination, while for pollen and exudates we usually take the substance as it is met with in commerce. In making a cross-section of a leaf it is well to make the same as near as possible to the midrib, which is also to be included in the section. The difference in the various drugs will be found to consist largely, if not entirely, of the different arrangement of



these various cells and organs. What the use and value of these various cells and organs are to the plant I will not discuss here, as that falls in the domain of botany rather than of microscopy. If I have by means of the above paper succeeded in inducing some of the many pharmacists scattered throughout the broad confines of our great country to make their first attempt at microscopical work, I shall feel amply repaid for my efforts, for it will only require the first effort to make the microscopist out of any of them; if not a microscopist, certainly a microscopical enthusiast, which will before long cause them to become full-fledged microscopists.

---

### MICROSCOPICAL APPARATUS.

---

**Substitute for Glass for Covers and Slides for the Microscope.**—I think the price of slides and covers for microscopic use is enormously high, and as they can be made of a substance much cheaper, and at the same time possessing properties which glass has not, viz., being unbreakable, that it should be known. In using celluloid, which is wood rendered soluble in ether and alcohol with gum camphor, for films for microphotography, I was struck with some of its properties that made me think it could be used in microscopy. It is transparent, almost as transparent as glass, unbreakable, the weight is very little, making it especially valuable when sending by post, and therefore occupying very little room, which can thus be dispensed with. It is strong as wood, and stronger, has no fibre, and can be cut readily with scissors. I really wonder that it has not been used before for slides and covers. It can be obtained with a ground surface as well as plain, and the cost, which is a great item, is next to nothing. Very thin celluloid films are commonly used for instantaneous coverers, and this can be employed for both, whilst the thicker kind used for ordinary photography makes capital slides. In fact I have some an inch square which I use in this way, mounting it temporarily in a glass slide for use on the microscope. Let all microscopists try it and they will not repent.—*Dr. A. M. Edwards in Science-Gossip.*

---

### BACTERIOLOGY.

---

**Bacterioidal Forms in Tissues and Eggs of Insects.**—Prof. F. Blochmann describes (in *Centralbl. f. Bakteriol. u. Parasitenk.*, ix, pp. 234-40) bodies which resemble in many respects bacteria. In the fat-body of insects, such as *Phyllodromia germanica* and *Periplancta orientalis*, these rodlets may be easily seen if a small piece of this tissue be squeezed between

cover-glass and slide, and examined in water or some indifferent menstrum. They may easily be demonstrated as cover-glass preparations and by staining with gentian violet. The rodlets are 6-8  $\mu$  long, and usually slightly curved. The ends stain deeply, while the middle part remains as a clear space. Sections exhibit the structure and relations of these bodies even better than cover-glass preparations. The material should be fixed with alcohol and stained with logwood, or by Gram's method.

The rodlets are seen singly or in pairs, the pairs being shorter than the single rods. In some cases there is an expansion at the ends which seems constricted off from the rod. Similar appearances were observed in some eggs of these insects.

Besides the two insects mentioned, the rodlets were found in many ants wherein they are longer, measuring 10-12  $\mu$ , and exhibiting in the middle a strongly refracting corpuscle, which became more visible after treatment with 1 per cent. acetic acid.

With regard to these bodies the important question arises whether we have to deal with bacteria living in symbiosis with the insects, or whether the bodies are products of the cells in which they are found. In support of the former view is the fact that Prazmowski has cultivated the bacterioidal forms of the Leguminosæ, while against it are the negative results of the author's own cultivation experiments.

**Decolorizing Bacillus obtained from Sputum.**—M. Le-grain isolated from phthisical sputum a bacillus which possesses in a striking degree the faculty of decolorizing solid nutrient media which have been stained with anilin dyes. From the experiments carried out, it would seem that this bacillus is identical with a species described by Cazal and Vaillard in the "Annales Pasteur," 1891. This decolorizing potentiality is intimately connected with the fact that the bacillus imparts a strong alkaline reaction to the medium in which it thrives.—*Jour. Royal Micr. Soc., August, 1892.*

**Bacteriosis of the Grape-vine.**—Sigg. G. Cugini and L. Macchiati describe in *Le Stazioni Sperim, Ital., 1891*, a new disease of the vine, which attacks the grapes in northern Italy, causing them first to turn brown, then to become dry and brittle. It is caused by a bacillus, about 3-4  $\mu$  long and 0.25  $\mu$  broad, usually solitary, sometimes united together in twos or threes, rarely into filaments.

---

## MICROSCOPICAL SOCIETIES.

---

SAN FRANCISCO, CAL.—WM. E. LOY, *Secretary.*

*July 6, 1892.*—The meeting was not largely attended, owing to the fact that so many members are out of town on their mid-summer vacation.

The secretary announced the receipt of the usual periodicals and journals to which the society subscribes, or which are sent in exchange, and by purchase two very important works, being Doctor Wolle's "Desmids of the United States" and the "Fresh-Water Algaë of the United States," the latter in two volumes. Acknowledgment was also made of a valuable monograph from the author, Arthur Mead Edwards, M. D., "On Examinations Made by Means of the Microscope of the Specimens of the Geological Survey of California."

The paper of the evening was read by J. H. Wythe, M. D., his subject being "The Ultimate Structure of Striated Muscle." The opinions advanced are the result of years of study and were not made public by the doctor as soon as he had reached the conclusion. Some of the preparations shown were mounted six years ago, and all were of a character to demonstrate the claims made by the doctor.

The paper was listened to with the closest attention, and all expressed themselves pleased and instructed. A vote of thanks was unanimously tendered the speaker for his valuable contribution to a subject of general interest to the scientific world.

August 3, 1892.—After the regular routine business the secretary announced the reception of the usual list of periodicals and transactions, together with a pamphlet on "The Examination by means of the Microscope of Specimens from the Geological Survey of California," second edition, from the author, Arthur Mead Edwards, M. D.

A cluster of carnation plants, on which some disease, fungous or otherwise, was preying, was received from John Pfenninger, of this city. The president requested that members who felt interested should take portions for investigation and report at the next meeting.

The paper of the evening was read by George Otis Mitchell, his subject being "The Principles of Microscopic Vision." At the outset Mr. Mitchell disclaimed any original work on this subject, but stated that he should merely give a *résumé* of the investigations and deductions of Professor Abbe and other eminent students of optics. In dealing with the subject of light, he said, we have left the realm of ponderable matter, with its comparatively slow rates of vibration, resulting in sound and heat, and have to treat of that manifestation of an unknown and unknowable cause, whose velocity is commonly estimated at 186,000 miles, and whose range of vibrations occupies the octave between 400 trillions and 800 trillions per second in round numbers. But one subtle form of energy is known to us, that of actinism, or chemical energy, whose laws have not yet revealed themselves.

A discussion of the various theories which have been propounded to account for the phenomena of light was not attempted by the speaker. The one now universally held was framed by Dr. Thomas Young, largely to account for a class of phenomena,

those of diffraction and interference, which were by no means satisfactorily disposed of in Sir Isaac Newton's corpuscular hypothesis. The theory is that light is the vibrations of imponderable particles constituting the hypothetical ether, a substance conceived as pervading all space and occupying the interstices of all ponderable matter.

Two of the phenomena of light demand particular attention—refraction and diffraction. It is a matter of early observation that light travels in straight lines. The dancing motes of dust in the air, illuminated by the beam entering through some crevice in the shutter, and the straightness of the beam, are familiar to every child. Later it is noticed that objects partly immersed in water seem to be bent at the water-line, and also that the coveted pebbles in the brook lie much deeper than he had supposed. These, with other phenomena of light, were illustrated by drawings very carefully made, and full explanations of the laws deduced from them were given. It would not be possible to give the explanations here without the diagrams, but all students of physics are more or less familiar with them.

The portion of Mr. Mitchell's paper of particular interest and value to users of the microscope was in relation to angular aperture in lenses. He said the question that led Professor Abbe to his researches into the nature of microscopic vision was, "Why does increased angles give objectives a greater resolving power?" The results of this investigation were listened to with the keenest relish, and the discussion which followed showed that members had given the matter considerable thought. At the conclusion a cordial vote of thanks was tendered Mr. Mitchell.

*August 17, 1892.*—This being a conversational meeting, no business was transacted further than to arrange for a field day in the near future, when those members who are interested will visit the ponds, lagoons, and beaches in the vicinity of the city in search of those minute forms of animal and vegetable life so interesting to the enthusiastic microscopist.

The paper presented was on the famous Santa Monica diatomaceous deposit, carefully prepared and read by Henry C. Hyde. The paper gave a brief account of the finding of this fragment by Thomas P. Woodward, now a school director in this city, but in 1876 connected with the United States Coast Survey. The gentleman was present as a visitor to the society, and gave a brief account in corroboration of what was read.

The fragment was a little larger than the dimensions of a long cigar box, and a portion was broken off to admit it into the box for shipment to this city, where it was sent to Henry G. Hanks, then in charge of the State Mining Bureau. An examination by Mr. Hanks at once revealed its character, but as he was not specially interested in diatoms, the bulk of the specimen was turned over to Professor Ashburner, who sent portions to various persons in the United States and in Europe who were interested in the subject.

Very soon he was deluged with inquiries as to where the deposit was located, and requests for more of the material. The fragment having been picked up on the beach below Santa Monica, where it had been left at high tide, and there being no ledge or stratum from which it might have been broken, Mr. Ashburner was unable either to send quantities of the material or locate the deposit.

Briefly stated, the Santa Monica deposit is famous for its peculiar combination of species of diatoms, for the large number it contained (Mr. Hyde had slides on exhibition containing 181 different species), for the rarity of many of these species, and for their wonderful beauty and brilliancy. No other deposit has yet been discovered which equals it.

In 1878 Mr. Ashburner received a letter from Charles Stoddard, of Boston, regarding the peculiarities of this Santa Monica deposit. It was remarkable, he said, for its great resemblance to the noted Barbadoes deposit. It contained numbers of rare forms, which were first published by Greville as occurring in the Barbadoes deposit, and one rare form found by this author in Moron, Spain; one by Ehrenberg as occurring only in Greece, and three species of Dr. William Gregory's diatoms of the river Clyde. Thus were brought together in one deposit species originally found in localities widely separated, both in time and space, without noticing the numerous common forms so universally distributed about the globe.

In most orders in nature, the speaker said, both in plant and animal life, there is usually a wide range of individual variation.

One result of this is that if carefully arranged in a certain series, one end of the series would show a close resemblance to an order quite distinct; while at the other end of the series there would be observed a like resemblance of its concluding forms to another and distinct order, so separated from it that the two could never for a moment be classed together. Not only is this observable in the larger orders of the animal and vegetable kingdoms, but it is equally so in orders within orders, sub-genera within genera, and even among species; until there would seem to be, from any point in the series, an ascending and descending scale of allied forms that to the mind not deeply scientific would defy classification. So in the diatoms, although undoubtedly vegetable, they are absolutely separated from their relations, the desmids, by the fact of their silicious envelope or outside skeleton, which is entirely wanting in the desmids. Yet certain forms in the two orders resemble each other far more closely than certain genera of each resemble other genera of its own order: for example, *Closterium* among desmids and *Epithemia* among diatoms; *Desmidium* among desmids and *Fragillariæ* among diatoms. Thus with a series of gradual changes from the forms just named, passing by slight gradations from one genera of the diatomaceæ to another, looking at isolated examples, it is difficult to believe they

could ever be brought into a series; for example, Bacillaria and Biddulphia, Diatoma and Coscinodiscus. Thus descending in the scale of tribes of diatomaceæ you approach in appearance to a group of atoms not vegetable, but animal, a group of the radiolaria called polycistina, marine animals as minute as many of the diatoms, and having, like the latter, a silicious covering or outer framework. It is an interesting feature of the Santa Monica deposit that it contains in combination a large number of the rare forms of polycistina also.

At the conclusion of the paper, the president expressed the gratification felt by all to the gentleman who prepared and read the valuable paper and conducted the exhibition.

### NEW PUBLICATIONS.

*The Pharmacology of the Newer Materia Medica.* Embracing the Botany, Chemistry, Pharmacy, and Therapeutics of New Remedies; in 15 monthly parts; subscription price \$3.00; single parts 25 cents. 8vo. pp. 1307. Detroit: Geo. S. Davis.

The object of this publication is to collect accounts of those new remedies that have been so rapidly introduced within the last few years, and to embody them into one comprehensive whole. The work contains reports of special botanists, results of physiological researches, and descriptions of pharmaceutical preparations. The botanical portion is especially valuable, as the descriptions are full, with, in many cases, illustrations of the plant and its parts, with further illustrations of its microscopical structure. Although the reports of clinical properties are in many instances founded on but one or two observations, and should for this reason be received as still *sub judice*, with only some probability of value, the work contains much information gleaned from the medical and therapeutical journals, and presents it to the practitioner in a condensed and convenient shape.

The treatment of its subjects is usually thorough, as far, at least, as its authorities enable it to be. A good example of this is to be found in its consideration of Coca, which includes synonyms, portion employed, natural order, habitat, properties, active principles, botanical description, history, production, cultivation, Coca at home and abroad, chemical composition, notes on the alkaloids, adulterations and substitutions, with general and clinical reports of therapeutic properties, and a complete literature of Cocana, covering 151 pages. The work has four extensive indexes, and although many of its clinical reports are doubtless too deeply rose-colored, it should not be neglected nor overlooked by those that desire to keep themselves informed as to the recent amazing progress of therapeutics and of the *Materia Medica*.



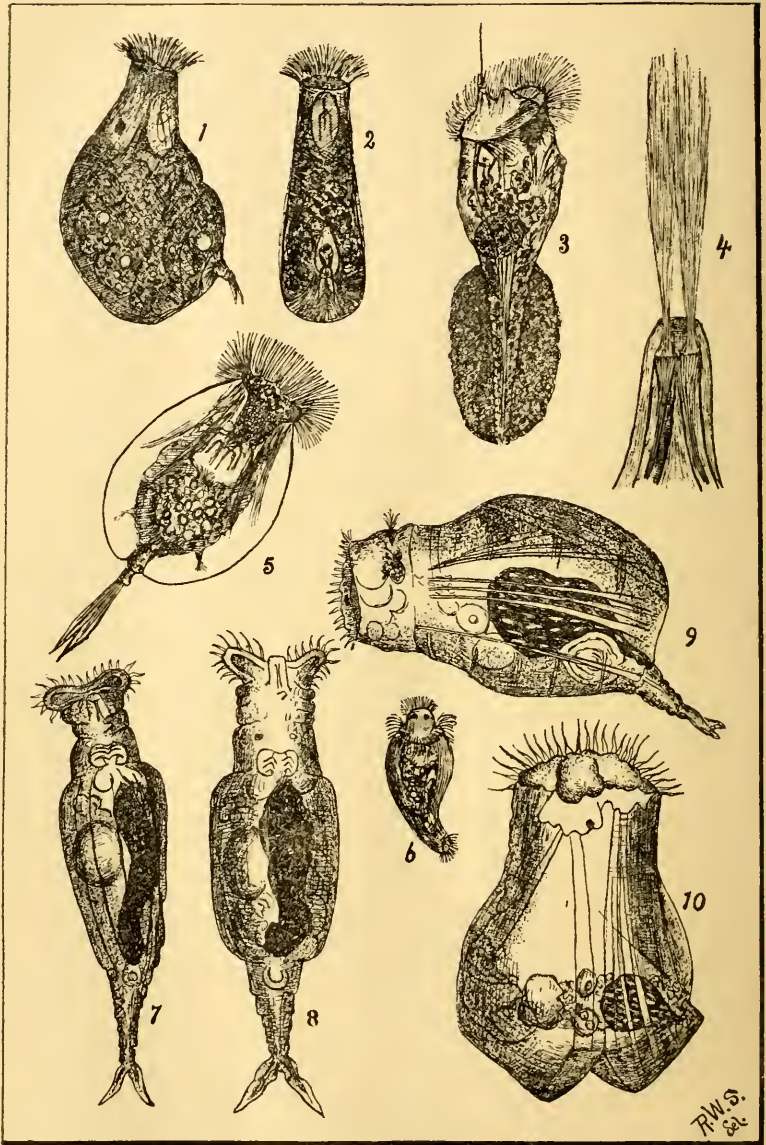

ROTIFERS.



# THE AMERICAN

## MONTHLY

# MICROSCOPICAL JOURNAL.

VOL. XIII.

DECEMBER, 1892.

No. 12.

### CONTENTS.

<p>Notes on New Rotifers.—  Rousset - - - - - 273  Callidina magna-calcarata.—  Parsons - - - - - 277  Notops clavulatus, Triphylus  lacustris, and Philodina  (species?).—Western - - 278  The Grasshopper, <i>Epidopa</i>  <i>carolina</i>; an Introductory  Study in Zoology.—Osborn 279  Microscopic Low Powers.—  Griffin - - - - - 282  The Brine Shrimp of the Great  Salt Lake.—Talmage - - 284  MICROSCOPICAL APPARATUS.—  A Cheap Microscope Lamp.—  (Illustrated) - - - - - 286  MICROSCOPICAL MANIPULA-  TION.—Practical Points in  Handling Objectives to Obtain  Best Definition. Using Oil-</p>	<p>Immersion Objectives. Gul-  land's Method of Fixing Par-  affin Sections to the Slide.  Geometrical Representation  of the Formula for Lenses.  Apparatus for Cultivating  Anaerobic Micro-organisms on  Solid Transparent Media.  Growth of Bacteria on Acid  Nutritive Media - - - - - 287  MICROSCOPICAL NEWS.—  Mr. E. H. Griffith. Washing-  ton Microscopical Society.  Postal Microscopical Club.  Bausch &amp; Lomb Optical Co. 290  MICROSCOPICAL SOCIETIES.—  St. Louis, Lincoln, Nebr. - 291  NEW PUBLICATIONS.—J. W.  Queen &amp; Co. Edgar Richards.  R. S. Bergh Henle - - - 292</p>
------------------------------------------------------------------------------------------------------------------------------------------------------------------------------------------------------------------------------------------------------------------------------------------------------------------------------------------------------------------------------------------------------------------------------------------------------------------------------------------------------------------------------------------------------------------------------------------------------------------------------------------------------------------------------------------------	-----------------------------------------------------------------------------------------------------------------------------------------------------------------------------------------------------------------------------------------------------------------------------------------------------------------------------------------------------------------------------------------------------------------------------------------------------------------------------------------------------------------------------------------------------------------------------------------------------------------------------------------------------------------------------------

### Notes on New Rotifers.\*

NOTOPS MINOR, CONOCHILUS UNICORNIS, AND EUCHLANIS PARVA.

BY CHARLES ROUSSELET, F. R. M. S.,

LONDON, ENGLAND.

*Notops minor*.—I have found this very small free-swimming Rotifer on several occasions in Epping Forest, and having obtained it again in some abundance, together with *Notops brachionus* and *N. hyptopus*, at our last excursion to Snaresbrook, I was enabled to study it in detail, with the result that it must be introduced as a new species. (Figs. 1 and 2).

In general appearance it much resembles *Notops hyptopus*, with its odd-looking little foot protruding high up from the ventral surface. So nearly does it follow its general characters that I at first thought that it might be the male of this species, but on examination with a high power this proved to be incorrect, as it has a large and well-developed mastax and digestive apparatus, and no sperm sac. The size of *N. minor* is only 1-250th to 1-270th of an inch—that is, only about a quarter of the size of

\* Extracted from Jour. Quekett Micr. Society, Vol. IV, No. 30.

Hyptopus, which often reaches 1-70th inch long. Towards the head the animal becomes constricted, forming a well-marked neck, only about one-third the width of the body at its widest part; this gives it a flask-shaped appearance and distinguishes it at once from Hyptopus. The body is greatly compressed laterally, more so than in Hyptopus, but widening slightly at the lower extremity. The ciliary wreath is simple and small and propels the animal rather slowly and deliberately through the water, while Hyptopus is a very brisk and active swimmer.

The brain is a very large hyaline sac, having some white, opaque granules at the tip, and just in front of these a large, square, crimson eye. The mastax, situated below the brain, is large and transparent, and contains forcipate trophi with four prongs. The stomach is very large and saccular, filling the whole of the body cavity, and containing a quantity of green and brown food. It is very difficult to distinguish the other organs, owing to the size of the stomach; a sausage-shaped hyaline organ near the foot looked like the ovary.

The small foot appears two-jointed, and protrudes high up from the narrow ventral surface, giving a very uncommon and odd appearance to the creature. The integument is yellowish in color, transparent, and rather stiff; it might almost be called a lorica. Near the foot is a small contractile vesicle, and also one vibratile tag. Eggs were not observed.

Summarizing the specific characters: The body is flask-shaped, much constricted anteriorly, forming a cylindrical neck, greatly compressed laterally; ciliary wreath small and simple; foot very small, arising from the ventral surface, carrying two small pointed toes, and capable of being completely retracted; trophi forcipate, integument leathery, transparent, and yellowish; size, 1-250th to 1-270th of an inch; habitat, Snaresbrook, Epping Forest, England.

**Conochilus unicornis.**—The genus *Conochilus* contains two species, *C. volvox* and *C. dossuaris*, to which I can now add a third. (Fig. 3.) I found this new species at a recent excursion to Keston, and propose to name it *C. unicornis* on account of its peculiar and prominent ventral antenna.

The corona closely resembles that of *C. volvox* in shape and structure, by having the buccal orifice on the corona towards the dorsal side a ciliated groove close within the edge, and a well-marked ventral gap in the ciliary wreath, but instead of having two ventral antennæ widely apart as in *C. volvox*, this new species has only one large antenna placed on the surface of the corona near the centre and surmounted by a single long and stout bristle, which can be retracted somewhat within the tubular sheath; this antenna is a conspicuous feature of the corona, and at once strikes the observer. Between the antenna and buccal funnel the skin of the corona is raised and forms a fleshy cone; this cone has a deep groove on the dorsal side running down to the buccal

funnel; the sides of the groove are thickly clothed with cilia, and have a lip-like motion capable of opening out or closing the groove more or less.

The mastax, digestive organs, and vascular system appear to be normal. The rami have four teeth and a number of ridges, which get smaller and smaller; these teeth and ridges were the first structures observable in a developing egg. The cloaca is placed high up on the dorsal side nearly on a level with the mastax. The brain and two red eyes are conspicuous; each eye consists of a minute, clear, refracting sphere, seated on a hemispherical cushion of red pigment. Four pairs of narrow bands of muscles are attached to the head below the corona and run down over the trunk to the extremity of the foot. The foot contains four sets of long and well-developed glands, reaching into the body cavity.

Both *C. volvox* and *Dossuarius* lay eggs, but in *C. unicornis* I have seen the fully-formed young, with eyes and moving jaws, within the mother, so that it is probable this species is viviparous, like an Asplanchna. The clusters consist of very few individuals, from two to seven living together in a gelatinous secretion; although rolling freely in the water, the clusters are more or less unsymmetrical. The size of the individual is 1-100 to 1-130 inch, which is very much smaller than *C. volvox*; the body is rather short, but the foot is short and does not much exceed the body in length.

In October, 1891, I paid a second visit to Keston and collected a large number of *C. unicornis*; the colonies were more vigorous than when first discovered and more numerous in individuals, some of the larger ones having as many as twenty to twenty-five individuals, but the majority of the colonies were smaller, and they continued to present a more or less symmetrical appearance. The single antenna, which is so conspicuous under a low power, is found, when seen from the ventral or dorsal side under a high power, to consist of two antennæ closely united, and inclosed in a single sheath. The stout bristle resolves itself under a very high power (1-10 apochromatic water immersion) into two brushes of very long and very fine setæ, and one belonging to each antenna, as shown in Fig. 4.

I have mentioned above that I have seen the young fully formed in utero; I have also seen it born. One egg was lying across the body on the ventral side and filling fully one-third of the whole body cavity. By degrees it was pushed toward the dorsal side, and then gliding slowly past the stomach and intestine it came out at the cloaca, which is situated high up on the dorsal side; I could see no trace of an oviduct, but it is evident that there must exist one, otherwise it will be difficult to imagine how so large an egg could find its way from the ventral side, past all the overlying viscera, to the cloaca at the opposite corner of the body cavity. When laid the egg was fully mature, with jaws moving incessantly, the eyes distinct, and the cilia playing around the

head; it remained a quiet rounded mass at the foot of the mother for about fifteen minutes, and then quite suddenly it swam around and took its place in the colony. In this, as also in a second egg, I could see no trace of an eggshell, but the difficulty of understanding how the young is born quite free, could remain folded together in the manner it did, even for a short period, made me watch a third egg with greater care, and this time I succeeded in making out an exceedingly thin, transparent, soft membrane covering the egg, totally unlike the thick chitinous eggshell we are accustomed to find in other Rotifers. When the young had emerged I could, with the best optical means, barely distinguish the outline of the collapsed membrane. Although, therefore, *C. unicornis* cannot, strictly speaking, be said to be viviparous, it comes very near to it.

In several colonies I found ephippial or so-called winter eggs; they are of the same size as the mature female egg (about 1-330th of an inch long), white, opaque, with a double shell; the inner shell is thick, granular, and has a tree-branch pattern on its surface, but no spines or scales; a distinct single ridge runs in an oblique direction all round the inner shell. The outer shell is thin, smooth, transparent. I also found some small mature male eggs, both in utero and lying at the foot of the mother, and then the male (Fig. 6), which is a small pear-shaped creature with a small ciliated head and a large wreath of cilia just below on a wider shoulder; two red eyes in the head are conspicuous; the body cavity is wholly taken up with the sperm sac, and the pointed lower end is ciliated as usual.

The specific characters may be summarized thus: Clusters more or less unsymmetrical, consisting of few (2-25) individuals, fused gelatinous tubes distinct; ventral antennæ joined together within a single sheath on the surface of the corona, large and conspicuous. Size of individuals 1-100 to 1-130 inch, of clusters 1-45 to 1-65 inch in diameter, male about 1-400 inch. Habitat, Keston, England.

*Euchlanis parva*.—This small but very attractive *Euchlanis* (Fig. 5) I have found on two occasions, the last time being at Keston. It can at once be recognized by its small size compared with that of its congeners, being only 1-130 inch in length, while all the other species of the genus are double the size and larger, 1-40 to 1-70 inch. The lorica is egg-shaped, of glassy transparency; the dorsal plate is arched, having a broad rounded notch anteriorly and a narrow notch behind. The ventral plate is much smaller and flat. The dorsal occipital edge of the lorica is extremely thin and transparent, and the broad notch can therefore only be well seen when the head is completely retracted.

The internal anatomy is normal; the brain is large and carries a red eye in front of the mastax; the lateral antennæ are quite conspicuous and protrude through the dorsal plate in the lumbar region on each side. In the other, larger species these are visible

with difficulty only. The short three-jointed foot carries two long blade-shaped toes; one of the individuals seen had one seta on the foot; the other, however, had none.

Recapitulating the specific characters: Lorica egg-shaped, dorsal plate arched, occipital edge broadly notched, posterior edge with narrow notch. Ventral plate small and flat. Size small, 1-130 inch without the toes. Toes rather more than one-third the size of the body. Habitat, Keston, England.

#### CALLIDINA MAGNA-CALCARATA.

By F. A. PARSONS, F. R. M. S.,

LONDON, ENGLAND.

*Callidina magna-calcarata*.—I have the pleasure of bringing to notice two Rotifers which are new to me. The one to which I will first refer is a *Callidina*, which I found on the excursion to Wood street in October, 1891. It is not, strictly speaking, new, for my friend, Mr. Western, to whom I forwarded some specimens, tells me he found it about two years ago, and Mr. D. Bryce also informs me that he has known it for some time. In endeavoring to discover if this Rotifer had been previously described I found mentioned in the "Supplement" of Hudson and Gosse a *Callidina* to which Kellicott gives the name *socialis*; his description of it agrees in several points with this, but does not fit it in all respects, so that, in the absence of drawings of *socialis*, I have come to the conclusion that Kellicott's Rotifer and this are different species.

I found it attached in pretty considerable numbers to the underside of *Asellus*, and Mr. Western has found it also on *Gammarus*. The body has numerous segments and has a very stout appearance when seated on the *Asellus*, with rotary organs expanded in the act of feeding; its greatest diameter lies towards the upper part of the body, where it enlarges rather suddenly. It then gradually tapers towards the foot. When swimming it is more elongated, and consequently less in diameter. The corona is broad, measuring about the same width as the largest part of the body when the animal is swimming. The column is stout, the tip furnished with what appears to be a ciliated cup with a hood-like projection extending partly over it. The dorsal antenna is small, surmounted by setæ, which are retractile by the invagination of the tip of the antenna. Number of toes normal. When the animal is crawling on the cover-glass, the toes have a lengthy and pointed appearance as they are withdrawn. The contractile vesicle is small, and is situated in the foot immediately below the intestine.

We now come to the most conspicuous feature in this Rotifer, viz., the spurs, two in number. These are large and striking, of gracefully curved outline, broad at the base, with heels at the

inner angles, narrowing towards the middle, then enlarging slightly to the base of the tapering point, the contour of which is slightly convex. This Rotifer is represented at Fig. 7.

NOTOPS CLAVULATUS, TRIPHYLUS LACUSTRIS, AND PHILODINA  
(SPECIES?).

By G. WESTERN, F. R. M. S.,

LONDON, ENGLAND.

**Notops clavulatus.**—The general contour is that of the female, even to the deep furrow at the posterior extremity, where the large lateral muscles are attached, and the vase-like form when the animal is seen from the ventral side is precisely similar; but there is no sign of the foot, which in the female is so striking a feature. From the total absence of the digestive organs the male appears much more transparent, and the many muscles, which are well developed in this species, are very apparent. I could make out no vascular canals, vibratile tags, nor contractile vesicle, though it is possible that the latter may be concealed in the mass of viscera which stretches across the body cavity from front to rear, the great bulk of which is made up of the sperm sac, inside which the spermatozoa, large and very active, can easily be seen. A large ganglion or brain carries an eye spot on its ventral side, and the numerous nerve fibres may be traced from it to various parts of the body. This male (Fig. 10) I found in a gathering from Richmond Park which Mr. Chapman has kept over three weeks. Subsequently I succeeded in hatching it from small white eggs which I had isolated for observation. From apparently similar eggs I have seen females also produced, but possibly further observation may enable us to distinguish the male from the female egg. There is another kind of egg, much larger and yellow in color, which is, I believe, the nesting egg. This I have not yet succeeded in hatching. The average length of males I measured was 1.40th inch.

**Triphylus lacustris.**—The male of this Rotifer (Fig. 9) is a reproduction in miniature of the form of the female, and it is from this similarity in appearance and its association with the female of the species that I have ventured to identify it, for I have not yet been able to trace it from the egg. The resemblance is not confined to outward appearances, for its internal organs will also be found to closely correspond with those of the female. The digestive viscera, however, as is usual with male Rotifers, are entirely wanting, and their space is occupied by the large sperm sac. I caught just a glimpse of a large penis protruded behind the foot. This male I found swimming amongst females in a rich gathering I made at Chingford. The average length was 1.83 inch. I may state that the females are very much larger than any I have hitherto seen.

**Philodina.**—I cannot identify this species with any of those described. The Rotifer is shown at Fig. 8.

LIST OF FIGURES IN THE FRONTISPIECE.

FIG. 1. Notops minor (side view).	6. Conochilus unicornis. Male.
2. " " (ventral view).	7. Callidina magna-calcarata.
3. Conochilus unicornis Female.	8. Philodina (species?).
4. " " Antennæ.	9. Triphylus lacustris. Male.
5. Euchlanis parva.	10. Notops clavulatus. Male.

## The Grasshopper, *Ædipoda carolina*; an Introductory Study in Zoology.

BY H. L. OSBORN,

ST. PAUL, MINNESOTA.

The great abundance of grasshoppers, their size and their affinities to the other insects render them an especially suitable and convenient subject for introducing students to zoölogical methods of thinking and working. It is possible in the autumn for each student to obtain abundance of material for the zoölogical study of the insects, and this he should be compelled to do, preserving the specimens in alcohol, to be carefully examined on the lines indicated in the present chapter. Specimens may be killed by atmosphere of chloroform and then preserved in alcohol, or they may be dried after chloroforming and mounted on pins as described in Packard's Entomology for Beginners. Dried specimens should be dampened with tepid water or water vapor prior to study. Of course the external parts only can be studied in this way, the internal anatomy being destroyed by drying.

### I. EXTERNAL ANATOMY.

The grasshopper presents a *body*, to which are attached movable organs, called *appendages*. The body is divided into three regions, which are called *head*, *thorax*, and *abdomen*. The head (Fig. 2) in front bears the mouth, with its appendages and the organs of special sense. The latter are (1) the two *antennæ*, a single pair presenting a number of joints united to the head by a single larger joint; (2) the *compound eyes*, globular dark bodies, whose surfaces are minutely subdivided into *facets*, which can be seen with the hand lens; (3) the three *simple eyes*, one above each antenna and in front of the compound eyes and one in the front of the head, between the two antennæ. The mouth, on the underside of the head, presents four movable sets of parts (Fig. 8): (1) an upper lip or *labrum*; (2) a lower lip or *labium*; the labium further presents a median bilobed portion and a pair of *palpi*, each 3-jointed; (3) the *maxillæ* on either side, just in front of the labium, each consisting of an inner portion of several pieces and a 5-jointed outer *palpus*; (4) the *mandibles*, a pair of heavy toothed pieces not

jointed or furnished with a palpus, lying just behind the labrum. The mouth-parts are used in biting hard sorts of food, *e. g.*, leaves of grass,\* etc.

The *thorax* (Fig. 1) consists of two parts, which are separate; one in front, the *prothorax*, connected to the head by a fleshy short neck, and the other, the *meso-meta-thorax*, bearing the *wings* and closely joined to the abdomen. The prothorax is covered with a saddle-shaped piece above and on the sides, called the *pro-notum*; and a narrow strip below, called the *pro-sternum*. At the junctions of these are sockets to which the legs are attached. The legs consist of movable pieces, called joints, whose names are as follows: 1, the *coxa*, next the body; 2, the *trochanter*; 3, the *femur*, long and narrow; 4, the *tibia*, also long and narrow; 5, the *tarsus*, consisting of four small joints ending in two claws. The *meso-meta-thorax* bears two pairs of wings and two pairs of legs. It consists, so far as concerns the external covering, of two pieces above, called *terga*, side pieces which slant obliquely, downward and backward, and show a line partly dividing them into two portions, and a central piece, the *sternum*, which transverse lines divide into 3 portions, one the *meso-sternum*, behind it the *meta-sternum*, and still behind it the first *abdominal sternum*. The meso-meta-thorax bears two pairs of legs and two pairs of wings. The former present the same joints as the leg of the prothorax, but the meta-leg is different from the others in that the femur and tibia are larger and longer, the femur containing the muscles which move the tibia. The wings are attached at the margins of the meso- and meta-terga. They are not alike, the front wings being oblong and stronger, while the hind wings are triangular and delicate, and when not in use folded like a fan beneath the former. The front border of the hind wing is stouter than the hind border. Both wings are marked by systems of lines called *veins*, which branch out into finer *veinlets* and strengthen the delicate tissue of the wing. Minute openings, called *spiracles* (Fig. 3), which admit air to internal breathing tubes, are located in the side wall of the thorax, just over the coxæ of the different legs.

The *abdomen* consists of a number of joints, *somites*, most of them alike and presenting a dorsal piece, the *tergum*, joined by a fold, the *pleurum*, to a ventral piece, the *sternum*. The front abdominal somite is unlike the others, its tergum being more like that of the meso- and meta-thorax and its sternum being separate from the tergum and joined with those of the meso-meta-thorax. The side wall of this incomplete abdominal somite bears the *car* (Fig. 3), which shows externally as an oval thin membrane. Behind this first incomplete abdominal somite are 8 more somites, which are alike, each one having its tergum and sternum and pleural fold. In the lower front portion of each tergum is located a spiracle.

\*To study this chapter from the specimen it should be read, verifying point by point upon a specimen drawing and indexing everything observed.



The hinder portion of the abdomen is different in the two sexes of grasshoppers. In the male the 9th and 11th sterna are large and curve upward, while the corresponding terga are very small and followed by a few small movable pieces, among which is located the vent and the opening of the genital gland. In the female the 9th and 10th sterna are represented by a portion which projects down and back; the terga are as in the male, but they bear parts which extend backward and upward. These diverging parts are used in boring holes in the earth to deposit the eggs, which pass out between them. The abdominal somites bear no limbs.

#### INTERNAL ANATOMY.\*

The parts within an animal's body form sets of organs called systems. Some of these are so soft and delicate that they require to be held in place by stronger matter which forms the *skeleton*.

In the grasshopper the skeleton is a shell composed of matter resembling horn, called *chitine*, which contains the soft living organs. Since this shell fits closely over the living organs in many of their parts we can learn a good deal about the animal by studying the external anatomy. But to have any adequate idea of the inner structure we must cut below the shell and explore among the parts within it. The parts of the body are called *organs*, each organ having a particular use or *function*; the various functions are of only a few kinds, and all the organs performing one general kind of function are called a system.

1. *The alimentary system* (Fig. 5) is composed of organs whose collective functions are to receive food and convert it into blood. It is a continuous tube, open only at the *mouth* and *anus*, whose cavity is entirely distinct from the cavity of the body, where the internal organs lie. It is divided into more or less separate chambers and receives ducts or passages from other alimentary organs which open into it. The mouth is the first organ of the system; it is furnished with lips and jaws, mandibles and maxillæ, which chew the food. Into the mouth cavity a tube opens from the *salivary glands* of each side which, lying chiefly in the thorax, secrete the blackish *saliva*. The mouth cavity continues upward as the *throat* and passes with a bend into the *crop*, which is an enlargement of the tube partially filling the cavity of the thorax; this receives the food and passes it back into the next organ, the *stomach*, which occupies the first four abdominal somites. Surrounding the hinder end of the crop are 8 blind pouches, called *gastric cæca*, which open into the crop. The stomach opens into a narrower tubular organ, the *ileum*, and this at its junction with the stomach receives a number of urinary tubes, *malpighian tubes*; the alimentary tube continues back as the *colon* and *rectum*

\*The more important points in the internal anatomy can be readily demonstrated by opening a specimen along the back under water, the specimen being pinned down upon a layer of wax in the bottom of a pan. The organ should be gently separated with teasing needles.

to finally open at the *vent* or anus at the tip of the abdomen. The alimentary system is thus a tube passing through the cavity of the body, having connected with and opening into it numerous other organs which are hollow but closed also to the body cavity. Therefore, substances eaten and swallowed being still in the tube are not in a position to reach and affect many of the organs of the body. To do this they must first pass into solution, and some of them undergo chemical change which enables them to pass or *dialyze* through the wall of the alimentary tube and thus reach the body cavity, whence they can go to the various organs. The salivary glands, the hepatic cocca, and to some extent the wall of the alimentary tube itself, have the power of producing fluids which when mixed with the food dissolve and alter it so that it can dialyze, this process being called *digestion* of the food. Some parts of the food are indigestible; they pass on as *faeces* into the colon and rectum to be discharged at the vent.

2. *The circulatory system* (Fig. 5) in the grasshopper is comparatively simple, as it is in all insects. It consists of a tube, the heart, with muscular pulsating wall, lying in the body cavity directly under the terga of the abdomen. The tube is closed behind, but open in front into an artery which passes forward to the head, where the brain lies. The sides of the heart have openings, *ostia*, a pair in each somite, which admit blood from the body cavity, and, the openings being furnished with valves, the blood is retained and pushed forward by the rhythmic pulsations of the heart. There are no capillaries or veins in this circulatory system, and hence only an incomplete circulation results (compare *Vertebrata*).

(To be continued.)

### Microscopic Low Powers.

BY FREDERICK W. GRIFFIN, PH. D.,

BRISTOL, ENGLAND.

The comparatively few microscopists who work with the lowest powers are doubtless fully aware of the advantages of daylight in their use. Lamplight, however, modified by tinted glasses and plane mirror, gives a glare with transparent objects, which tries the eyes and seriously impairs definition. I find, however, the new "Zeltnow cupro-chromic light-filter," which has proved so valuable with high powers, to be equally useful with the lowest. It gives a pale green field, as reposeful to the eye as daylight itself, while a blaze of light is tempered down to due working pitch. All fine details, as the rings of delicate tracheæ, or the markings of a dotted surface, are shown up with the sharpest definition. Of course, color is mainly obliterated in this monochromatic illumination, the picture being virtually in monotone, like

a photograph or engraving. Hence this medium is scarcely suitable where color is a leading feature of the object. The solution should be contained in a flat bottle, with clear, polished, parallel sides, as supplied by Baker, and probably other dealers.

One regrets that the lowest powers (4 in. and under) are so little employed by natural-history observers and amateurs. They afford very useful general views of entire objects, and many striking and beautiful pictures, especially with binocular. This disuse arises from the fact of ordinary microscopes seldom having rackwork sufficiently long to allow of the focusing of very low powers. But a simple adaptation will permit the object to be placed below the stage, so that even a 5-inch objective may be adequately worked on almost any stand. The instrument is likewise kept steadier, more compact, and less liable to injury than when left out to an extreme length. When there is a "substage" a square plate may be provided with a short tube fitting beneath, so as to fix on the top of it. This may have either springs or a sliding bar. The former holds a mount securely during rotation, should this be desirable (which is, however, seldom the case), but prevents the use of large "growing tanks." If a bar is employed for these, an upper one, or even, on occasion, elastic bands passed over the ends, would be needed to secure mounts if rotated. In using tanks it is almost superfluous to point out that the brass plate must be as much below the optical axis as the whole height of the tank, *plus* width of the sliding bar, or the top of the tank could not be brought into the field of the microscope. A polarizing prism could often be used in the bottom of the substage; but ordinary-sized Nicols, even when brought up close to the slide, cut off so much of the field as to make it ineffective for display.

A 5-inch objective needs a prism of a clear inch aperture to avoid "cutting off," and this is large and costly. The above arrangement is all that can be desired for transparent objects; but if the substage does not rack far down there may not be sufficient space between it and the bottom of the main stage to admit of the convenient illumination by bull's-eye of opaque objects in deep cells. In such case it is better to attach the supplementary stage to a separate sliding-piece in the substage dovetails, or even by projecting pins dropping into holes in some solid part of the stand. The latter plan would be available with simple and only moderate-sized stands.

Finally, I may remark that this same want of accommodation in the ordinary rackwork has led makers to nominally much underestimate their low powers. A 4-inch objective should magnify just four times less than a 1-inch; but I find by numerous careful camera measurements, and assuming a 1-inch by Powell and Lealand as a standard, that a 3-inch objective is really about a  $2\frac{3}{4}$ -inch, and a 4-inch some  $3\frac{1}{3}$  inches. The so-called "4-inch" objective is, by the catalogues, the lowest power made; but

Mr. Wray, of Highgate, has recently made, by request, for a friend of mine, a "5-inch" (true  $4\frac{1}{2}$ -inch) of superb quality for a "triplet" or "single-system" glass. With E ocular it preserves perfect definition, and gives the spirals of tracheæ and similar details with full sharpness and absence of color dispersion. Were there any demand, I have no doubt that makers could produce a true 5-inch objective (which they would probably call "6-inch") of equal merit.—*English Mechanic*, Nov. 18, 1892.

---

### The Brine Shrimp of the Great Salt Lake.

By J. E. TALMAGE, PH. D., F. R. M. S.,

SALT LAKE CITY, UTAH.

The brine shrimp, *Artemia fertilis* (Verrill), is a tiny crustacean abounding in the water of the Great Salt Lake. They frequent the surface; indeed I have never taken a specimen from a depth beyond two feet. They may be found in the lake at all seasons, though they are most numerous between May and October. I have taken them in the midst of winter, when the temperature of the water was far below the freezing point; it will be remembered that the concentrated brine of the lake never freezes. The females greatly preponderate; in fact, during the colder months it is almost impossible to find a male. In the latter part of summer the females are laden with eggs, from four to sixteen having been repeatedly counted in the egg pouch. The males are readily recognized by the very large claspers upon the head.

The artemiæ frequent the shores during calm weather, but rain drives them into the lake. Oftentimes they congregate in such numbers as to tint the water over wide areas. They are capable of adapting themselves to great variation in the composition of the water, as must necessarily be the case with any inhabitant of the Salt Lake, for that body of water is subject to wide fluctuations in bulk and composition. Aside from the long periods of rising and falling of the waters, there are great annual variations caused by the relative supply of water through rain and snow-fall and the loss by evaporation. Beside the annual fluctuation, the lake is at present steadily falling, and the waters are consequently growing more concentrated. I have specimens of artemia gathered from the lake in September, 1892, and the water taken then showed on analysis 14.623.23 grains of dissolved solids to the imperial gallon, the greater part of this being salt. Indeed I have captured the creatures in the evaporating ponds of the salt works, where the brine was near its point of saturation. It is not difficult to accustom them to a diluted medium; I have kept them alive for days in lake water diluted with 25, 50, 80, and 90 per cent. fresh water, and from eight to eighteen hours in fresh water only. Of course the changes from brine to fresh water were made gradually.

As to their food, in captivity they live upon meat, bread, or vegetables, and in fact upon almost anything in the nature of food, and they are not slow in attacking the bodies of their own dead. In the lake they probably subsist on the organic matters carried down by the rivers, upon the marine algæ which flourish about the shores, and upon the dead larvæ and the pupa cases of a fly, which are found in the water in great numbers.

During a cruise upon the lake in September of the present year the crustaceans were found in great abundance. When near the middle of the lake, with a small tow net, we soon took a quart of the shrimps, and thereupon resolved upon an experiment the subsequent recital of which has shocked the gastronomic sensibilities of some of my dearest friends. Reasoning that the bodies of the artemiæ were composed largely of chitin, we concluded that the question of their palatability was at least worthy of investigation. By a simple washing with fresh water the excess of lake brine was removed, after which the shrimps were cooked with no accompaniments save a trifle of butter and a suggestion of pepper. They were found to be actually delicious. If the artemiæ could be caught and preserved in quantity, I doubt not they would soon be classed as an epicurean delicacy.

The mounting of the crustaceans for permanent microscopical use is by no means a simple undertaking, most of the ordinary media causing the delicate structure to become distorted, or producing such a transparency as to render the whole object invisible. The method which I now use is to mount them in a preparation of lake water, with corrosive sublimate and an alcoholic solution of carbolic acid. Into this fluid the living artemiæ are transferred directly from the lake brine; they die quickly, but in so doing spread themselves out most perfectly. By this method it is not always possible to get the mount free from foreign particles, but this is but a slight disadvantage. Before mounting I make a very shallow cell of hot paraffin and balsam, and after the cover-glass is in position I ring the edge with a very little of the same material, following this with repeated layers of cement, King's preferred.

The popular literature of the day still declares that no living thing can exist in the Great Salt Lake. The perpetuation of this error is inexcusable. It is true, but very few species of animal life have been found in the concentrated brine of the lake, but some of these species there abound. Among the forms of life already reported as existing in the lake I have confirmed the presence of four: (1) the *Artemia fertilis* (Verril); (2) the larvæ of one of the Tipulidæ, probably *Chironomus oceanicus* (Pack); (3) a species of *Corixa*, probably *Corixa decolor* (Uhler); (4) larvæ and pupæ of a fly, *Ephydra gracilis* (Pack). Of the last-named insect the larvæ are found in numbers near the shore, and the pupa cases in the spring and summer wash ashore in great numbers; there they accumulate, undergoing decomposition with powerfully odorous emanations.

Much has been said at different times as to the possibility of adapting fish to a life in the lake. In the absence of all experiment it would be rash to conjecture, though it would seem unlikely that fish could thrive in such a brine; but the fear expressed by some, that even if fish could be accustomed to the lake they would starve, is unfounded: for certainly the food supply is abundant. The vegetable life of the lake is a subject worthy of investigation and one which at present is practically untouched.

### MICROSCOPICAL APPARATUS.

**A Cheap Microscope Lamp.**—Mr. Wm. D. Grier, the well-known microscopist of Boston, Mass., sends us the following description of a lamp which he has found both economical and useful in his microscopic work:

During the past few years I have seen in the journals directions for making almost everything, from a dissecting microscope to a slide-box, but no one has yet suggested a home-made lamp. Unfortunately "illuminators" are expensive luxuries, and the following description of one which I rigged up in a moment of inspiration may be of use to some whose desires are, like my own, very much larger than their pocket-books. The component parts and their prices are as follows:

A small kerosene lamp with a flat wick . . . . .	.75
A two-ring retort stand . . . . .	.65
A "tube clamp," No. 5959 of Eimer & Amend's "Prices Current" . . . . .	.50
A piece of ground glass, 4x5; ditto of white card-board; ditto of sheet brass, lead or tin, 5x7; 18 inches of 1-16 brass wire . . . . .	.25
Total . . . . .	\$2.15

Cut the sheet metal like fig. 1, place the ground glass on it and bend the ears *a* over to hold it in place; bend the long piece *b* as in fig. 2.

Put the lamp on the large ring of the stand and lower the small ring over it, clamping it firmly at any desired height. Clamp the ground glass in place with its centre in line with the flame. bend the brass wire as in fig. 3, slip the helix *c* over the upright rod of the stand and place the card in the two little bends at *e*, and the lamp is ready for use. An ordinary side condenser can be substituted for the ground glass, and a cheap tin reflector for the card. I use the lamp in this way for photo-micrography and find it excellent. If a blue glass is desired, thoroughly clean a spoiled 4x5 dry plate or other piece of clear glass the same size, and flow with "King's transparent blue lacquer;" don't apply

the lacquer with a brush, as it leaves unsightly ridges. Nearly all retort stands have light bases; therefore remember that when the "centre of gravity falls outside the base" you are very likely to "hear something drop."

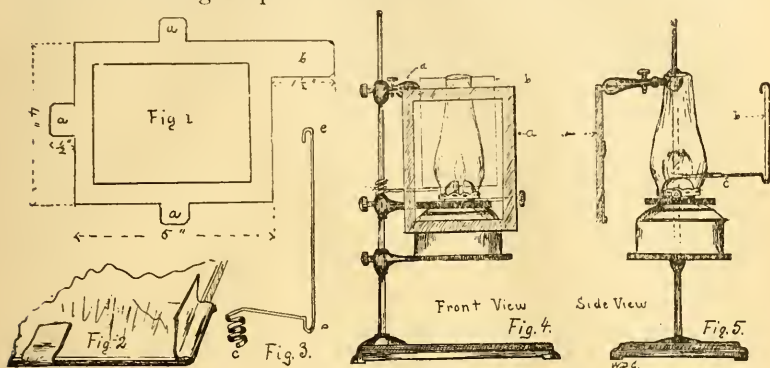

EXPLANATION OF PLATE.

a. Frame of ground glass.  
b. Card reflector.

c. Wire support for reflector.  
d. Clamp.

By the way, a  $\frac{1}{8}$ -inch thin glass circle, if coated with the blue lacquer and stuck on the lower end of the cylinder holding the diaphragms (in a continental stand) with a little paraffin, makes a good "moderator" for night work.

## MICROSCOPICAL MANIPULATION.

**Practical Points in Handling Objectives to Obtain Best Definition.**—If you want to compensate for thinner cover-glass, set the systems of your objective further apart; or the same purpose may be effected by lengthening the tube of your microscope. If, on the contrary, you want to correct for a thicker cover-glass, set the systems closer, or make your tube shorter.

I. Thicker cover, longer tube, and opening systems tend to over-correction.

II. Closing systems, thinner cover, and shorter tube tend to under-correction.

For the recognition of under or over correction by the appearance of the object, the writer has found the method of E. Gundlach to be of great practical value; and he would urge careful practical study of these appearances as affording a guide to the kind of correction needed, whether "under" or "over."

To illustrate the practical use of the above, suppose, for example, a condition of under-correction of "general spherical ab-

beration"; then either of the conditions named will afford counter-action or correction. *i. e.*, either thicker cover-glass, longer tube, or opening systems of objective, whichever may be most convenient or practical. It is, of course, in many cases impossible to alter the distance of lens-systems, owing to the objective being in a fixed mount, not adjustable; in such cases one of the other correctives may be applied.—*E. Pennock, in Queen's Pocket Catalogue.*

**Using Oil-Immersion Objectives.**—In using these objectives cleanliness is important. Only a small quantity of the immersion fluid (specially prepared cedar oil) should be used, and it should be wiped off as soon as possible when done using.

To remove the oil, blotting-paper should be used, and then, breathing on the front lens, wipe it lightly with a piece of clean, soft linen.

In order to keep the immersion fluid unchanged, it should not be exposed to the air for any length of time, as exposure to the air will thicken it, and so alter the refractive index.—*E. Pennock.*

**Gulland's Method of Fixing Paraffin Sections to the Slide.**—After pointing out the difficulties arising from the use of the albumen fixative, the author offers the following method:

The tissue is imbedded in the usual manner. In trimming the block for sectioning, care must be taken to see that the surface meeting the razor is exactly parallel to the opposite surface; these surfaces are then coated with soft paraffin, and when this has hardened are again trimmed square. The reason for this special care is that any curve in the ribbon produced by neglect of this precaution is accentuated by the later flattening of the sections. When all the sections required have been cut, the ribbon is divided into lengths corresponding to that of the cover-glass in use.

A flat glass dish filled with warm water is now provided; the temperature should never be high enough to melt the soft paraffin holding the sections together. Short of this, however, the warmer the water the more rapidly and completely are the sections flattened.

The ribbons are seized at one end with forceps while the other end is gently lowered upon the surface of the warm water; as the sections flatten out they will move along the surface of the water; when the flattening is complete, the slide, carefully cleaned, is immersed in the water. The ribbon is floated into its position with a stiff brush; this process is repeated until the slide is full, when it is set up on end until the water is thoroughly drained off. The slide is then transferred to the top of the imbedding oven, where the temperature is a little under 50° C., and where, consequently, the paraffin of the sections is not melted, though the water rapidly evaporates. The slides are kept there with a card-board cover over them to keep off dust, until the evaporation



is complete and the sections adhere to the slide. The time required for this varies according to the thickness of the sections; for thin sections one hour is generally sufficient for complete fixation, but the important point is that *the paraffin must never be melted until the last trace of water has disappeared from the slide*. If this premature melting happens by any accident, the sections are certain to peel off later. A few experiments enables one to be sure of the point when the slides are safe.

After complete fixation the paraffin is melted by putting the slide inside the oven and then washed off with turpentine or xylol.

One of the great advantages of this method is the perfect ease and safety with which it allows sections on the slide to be manipulated, so that the most various stains and reagents can be applied successively to a slide, *e. g.*, the complicated processes used to demonstrate bacteria in the tissues can be applied, with the certainty, moreover, that there is nothing on the slide to be stained which was not in the section.—*American Naturalist*, November, 1892.

#### Geometrical Representation of the Formula for Lenses.

—M. d'Ogagne states in *Central-Ztg. f. Optik u. Mechanik*, xiii (1892), that by a well-known construction the magnitudes occurring in the formula

$$\frac{1}{p} + \frac{1}{p'} = \frac{1}{f}$$

may be represented by the distances in which a straight line rotating about a fixed point cuts two rectangular axes, and the distance of the centre of rotation from the centre of the co-ordinates. He remarks that this construction is more convenient if the axes are taken as intersecting at an angle of 120° instead of 90°.

**Apparatus for Cultivating Anærobic Micro-organisms on Solid Transparent Media.**—Dr. A. Trambusti describes in *Centralbl. f. Bakteriöl. u. Parasitenk.*, xi (1892), pp. 623-4, an apparatus which he has devised for cultivating and examining anærobic microbes.

It is made of glass and consists of two parts, the lower of which resembles an inverted funnel, while the upper is cylindrical. In the latter are two openings, the top one tightly closed with a stopper, while that at the bottom is very small. Inside the cylinder is a smaller one which is in communication with the funnel-shaped clasp or lower portion of the apparatus. The apparatus is used as follows: The medium, already inoculated, is spread on the bottom of the flask and then this is closed by placing the cylinder on it. Into the latter is then poured as much of the ordinary pyrogallate of potash solution as may be necessary to absorb all the air in the apparatus. The stopper having been put in, the whole apparatus is placed in the thermostat. Two gm.

of pyrogallic acid to 15 ccm. of 1 in 10 potash solution are sufficient to extract all the oxygen.

Colonies of anærobic micro-organisms are said to thrive very well in this apparatus and are quite easily isolated. The apparatus has the further advantage that the growth of the colonies is easily examined through the thin bottom and their shape studied just as in Petri's flasks. If the pyrogallate solution is shaken up occasionally the absorption of the oxygen is accelerated.

**Growth of Bacteria on Acid Nutritive Media.**—The most prevalent notion as to the reaction of cultivation media is that an alkaline or neutral reaction is almost absolutely necessary. In order to show that an acid reaction is not so very inimical to bacterial growth, I have made a series of experiments with some of the best known bacteria such as *Bac. typhosus*, *Bac. anthracis*, *Staph. pyogenes aureus*, Friedlaender's pneumonia-coccus, the coccus of erysipelas, and others. The basis of the medium was ordinary gelatin or isinglass mixed with 1.25 gm. pepton, 1.25 gm. NaCl, and 250 gm. water. To this mixture I add acids (lactic, tartaric, citric, acetic, hydrochloric) or alum in various degrees of concentration. The cultivations are made in test-tubes at temperatures varying from 16° to 23°.

The results, carefully tabulated and recorded, amount to this, that a large number of bacteria grow on acid media, some indeed very well, provided that a certain degree of acidity be not exceeded. The maximum acidity of the medium I have found to vary extremely for each different species. The only schizomycete which would not grow at all on any acidified was the micrococcus of erysipelas, while the *Bacillus anthracis* grew even when the medium contained 0.2 per cent. of lactic acid, and with 0.2 per cent. of alum its growth was better and more rapid than on neutral media. Nor was the virulence of the anthrax diminished, as proved by inoculation experiments on mice.

It appears that the biological characteristics of some fission fungi are brought out very clearly on acid media; among these may be mentioned the bacillus of typhoid and the bacillus of blue milk; the latter grown on isinglass decoction, to which 0.2 per cent. of lactic acid has been added, develops its well-known pale blue hue, a phenomenon which does not occur on alkaline substrata.—*Herr G. Schlüter, in Centralbl. f. Bacteriol. u. Parasitenk., xi (1892).*

### MICROSCOPICAL NEWS.

Mr. E. H Griffith, the well-known microscopist, and family have located in Chicago, Ill. Their present address is 5656 Washington avenue, that city.

Washington Microscopical Society, for the cultivation and advancement of microscopical science, filed articles of incorpora-

tion at a recent meeting. The officers are V. A. Moore, president; E. A. Gibbs, vice-president; W. W. Alleger, corresponding secretary; L. M. Moores, recording secretary; J. M. Yznaga, treasurer, and W. H. Seaman, curator.

**Postal Microscopical Club.**—The management of the American Postal Microscopical Club announces that Dr. S. G. Shanks, of Albany, N. Y., has consented to assume the office of secretary of the club, which has unavoidably been vacant for some time past. The Doctor will take charge of the department of slides and their circulation; and all communications pertaining thereto should hereafter be sent directly to him.

**Bausch & Lomb Optical Co.**—In speaking of the visit to this well-known firm's optical works during the recent meeting of the American Microscopical Society in Rochester, the society's report says: "Nearly two hours were occupied by the visitors in inspecting the works and in endeavoring to see at a glance what could not be satisfactorily seen in two days. All of the five hundred employés of the factory were at work, and the tour of the various departments was extremely interesting. All questions were answered by the guides with the utmost courtesy; the spectacled professor was enabled to see just how his spectacles were made, from the edge of the rim to the centre of the lens; the enthusiastic microscopist could there watch his instrument grow under his eyes, from its beautiful heavy brass standards to the tiny lens against which he so often places his eye; the photographic expert could here witness the making of all the finest apparatus which modern invention is adding to the art of photography. In fact, the great building, from its throbbing Corliss engine below to its classifying-rooms at the top, was a rare treat to the visitors and one thoroughly appreciated by them.

---

## MICROSCOPICAL SOCIETIES.

---

THE ST. LOUIS CLUB OF MICROSCOPISTS.—S. E. BARBER,  
*Secretary.*

*October 7, 1892.*—The regular meeting was held at Secretary S. E. Barber's rooms, 1721 Washington ave. Mr. R. E. Schlueter was unanimously elected a member. The club discussed the advisability of giving a microscopical soirée in the near future, which met with much favor. The same will be discussed more fully at the next meeting, and the date of its occurrence will be settled. This soirée will be given in the rooms of the new St. Louis College of Pharmacy, 2108 and 2110 Locust street, and members from all clubs in the U. S. will be invited, as well as all leading microscopists. Ladies will also be invited, and the

affair promises to be a very brilliant event, which will enable the world to see what the microscopists of St. Louis are doing towards the advancement of this science.

MICROSCOPE CLUB, LINCOLN, NEBR.—ROSCOE POUND, *Sec'y.*

*October 25, 1892.*—The principal object of interest was an exhibit by Mr. Dales. He had experienced considerable difficulty in obtaining optical blue glass discs for modifying the light. All glass which he had obtained in this country was blue on one side only, and did not answer the purpose. As a substitute he painted a piece of mica on one side ultramarine blue and pounced it before dry. This placed between the light and the instrument served very well.

### NEW PUBLICATIONS.

*Illustrated Catalogue of Microscopes.* J. W. Queen & Co., Philadelphia. 75th edition.

The microscopist that would, if he could, have all the optical luxuries offered in the makers' seductive lists will take pleasure in reading this new edition of a well-known catalogue. The mere reading is a satisfaction to the microscopist as the reading of a publisher's catalogue is a satisfaction to the lover of books, although he may not be able to buy a tithe of all the wares so delightfully displayed to tempt him. Queen's new list has been in part rewritten and rearranged, and has received a welcome addition in the form of an index. It is dated from the firm's new quarters, at 1010 Chestnut street, where they have now gone, as the old place has for some time been too limited for their business. The pamphlet is a good thing to have within reach, and can be obtained for the asking.

*Annual Address of the President, Mr. Edgar Richards,* before the Chemical Society of Washington. Some Food Substitutes and Adulterants. (Reprint.)

*Recherches sur les noyaux de l'urostyla grandis et de l'urostyla intermedia,* par R. S. Bergh, de Copenhague. (Reprint.)

*Of the Teeth.* Henle. Translated for the *Odontographic Journal.* (Reprint.)

# THE AMERICAN MONTHLY MICROSCOPICAL JOURNAL.

## INDEX.

	PAGE.		PAGE.
Abbe illuminator, S. H. Gage.....	81	Carbon .....	44
Acknowledgment.....	86	Carter, F. B., radiolaria, 63, 111, 143, 177, 216, 257	122
Actinomycosis .....	45	Cedar trees .....	122
Actinosphærium eichorni .....	236	Celluloid for slides .....	267
Agassiz .....	121	Cement .....	41, 67
Air bubbles .....	40	— examination of .....	195
Algæ, dried.....	17	— transparent .....	146
— key to .....	174	Clathrulina elegans .....	236
American Microscopical Society... 145,	201	Cleaning objectives .....	86
Amœba proteus .....	234	— paper for .....	99
— radiosa.....	234	Clinical college of medicine.....	149
— villosa.....	235	Closterium angustatum.....	155
Amphipleura pellucida.....	17	— lineatum .....	154
Antwerp, Microscopical exhibition	20, 133, 170	— maculatum .....	154
at .....	20, 133, 170	— robustum.....	154
Apparatus, microscopical, 1, 15, 39, 65, 66, 98, 120, 157, 165, 192, 219, 267, 286, 289	122	Clover, scarlet .....	101
Apple rust .....	122	Codosiga umbellata .....	237
Arbor Day .....	122	Collecting sediment .....	16
Arthritis.....	19	— terrace dust.....	167
Aubert, A. B., index of refraction.....	25	Columbian Exposition, microscopy at	74
Bacillus decolorizing.....	268	Condenser, Abbe .....	81
— influenza.....	40, 43, 71	Conochilus unicornis.....	274
— Klebs-Loeffler .....	73	Correspondence, 47, 74, 103, 151, 175, 198	198
Bacteria .....	44	Cotton crop .....	71
— growth of .....	290	— seed, troublesome.....	19
— in street dust .....	102	Cox, C. F., diatoms, items on.....	32
— motile .....	3	Crime, detecting .....	68
Bacteriology, 43, 71, 102, 124, 160, 170, 245, 267	245, 267	Crystals, silver.....	13
— and hygiene.....	245	Cunard Steamship, trip on, C. W. Smiley.....	118
Bacterium, new .....	102	Cunningham, K. M., Diatomology..	249
Bacteriosis of grape-vine .....	268	Cutting glass tubes... ..	67
Bausch & Lomb.....	150, 291	Dark room, to arrange.....	167
Beale, W. J., continuity of protoplasm	129	Dawson, C. F., potato section cutter.	243
Beer .....	44	Dead black.....	121
Biedert's method .....	170	Decolorization of objects.....	110
Biological examination of potable	55	Desiccation, life after.....	17
water .....	55	Desmid, a new, W. N. Hastings .....	29
Biological notes, 17, 41, 70, 101, 131, 147, 169	169	Desmids and diatoms.....	32
Biology, elementary, H. L. Osborn...9, 26	9, 26	— from N. H., W. N. Hastings . . .	153
— Practical studies in, H. L. Osborn.....	87, 105	— how to collect, W. N. Hastings.	113
Bread, adulterated.....	46	— key to.....	174
— fermentation of .....	18	Diagnosis, microscope in .....	45
Brine shrimp, J. E. Talmage .....	284	Diatomaceæ, A. M. Edwards .....	212
Brownian movement.....	46	Diatomology, K. M. Cunningham... ..	249
Brucke, E. W.....	37	Diatoms.....	42, 71, 148
Bulloch, W. H., death of.....	29	— and desmids.....	32
Bumble-bee in New Zealand .....	42	— arranged .....	125
Calligina magna-calcarata .....	277	— assorting .....	32
Camera, a cheap.....	167	— classification of .....	34
—, for micro-photography .....	39	— deposits of .....	36
		— gemmation of.....	35
		— items on, C. F. Cox .....	32

	PAGE.		PAGE.
Diatoms, knowledge of .....	36	Hayes, Dr. Justin R.....	173
— locomotion of .....	33	Hepatica triloba.....	17
— material.....	46	Hyalosphenia cuneata .....	235
— Mobile deposit.....	169	Hydra viridis sectionizing... ..	189
— motion of .....	35	Hydroxy-lamine, use of.....	68, 100
— multiplication .....	42	Hygiene and bacteriology.....	245
— notes .....	20	Illumination, dark ground.....	84
— of Conn., W. A. Terry, 185, 230,	253	Illuminator, Abbe.....	81
— photomicrographs of .....	67	— electric .....	67
— remains of.....	36	— Stratton's.....	1
— self-division of .....	35	Images, for color .....	85
— to mount dry .....	123	— refraction.....	84
— to work .....	122	Imbedding .....	117
Diffugia pyriformis .....	235	— animal tissues, H. L. Osborn ...	116
Diphtheria, germs of .....	19	Immersion oil, glass for.....	15
Disease of the potato .....	124	Influenza .....	19
Dohme, A. H., microscope in phar-	262	— bacillus of.....	40, 43, 71
— macy .....	262	— prevention of.....	45
Drawing, Smith's method of.....	121	Ink .....	110
Druggist, microscopy for.....	149	Insect, sugar .....	46
Durkee's electric illuminator.....	67	Kellicott, D. S., rotifer notes.....	12
Dust injurious .....	45	Knott, L. E., grapho prisms .....	12
Edinger's drawing apparatus.....	65	Labels, gum for.....	100, 197
Editorial.....14, 38, 65, 96, 118, 145, 163,	190	Lamp, a cheap .....	286
Edwards, A. M., species in the Dia-	212	— Lane-Sear.....	165
tomaceæ .....	212	— microscope.....	2
Eggs of insects, bacteriological forms	267	Lamp-light .....	82
in.....	267	Lankester, Dr. Ray.....	65
Electrocution, effects of.....	147	Leeuwenhoek Microscopical Club, C.	210
Euastrum magnificum.....	153	W. Smiley .....	210
Euchlanis parva.....	276	Lenses, formula for.....	289
Eye-piece, analyzing, W. Lighton....	260	— how made.....	47
— S. & S. Aplanatic.....	103	— making.....	103
Eyes, crustacean.....	16	Levy, Adolph, sterilizer.....	192
Exchange notices.....	80	Lieberkuhnia .....	236
Figs in California.....	62	Life after desiccation.....	17
Fiord, Hudson river.....	123	— duration of.....	42
Fishes, parasites of.....	71	— in Great Salt Lake.....	18
Forbes, S. A., all-around microscope,	91	Lighton, W., analyzing eye-piece....	260
Frog, the.....	9, 26	Lignite, preparing .....	146
Fungus, circular growth of.....	101, 169	Living forms, confining.....	41
— study of.....	121	Low powers, F. W. Griffin.....	282
Gage, S. H., Abbe illuminator.....	81	Lungs, dust injurious to .....	45
Garments, examining .....	68	Lycopodium.....	125
Gibbes, H., micro-organisms.....	141	— adulteration of.....	50
Glue, liquid .....	86	McIntosh, L. D., death of .....	103, 172
— without heat.....	132	Magnification, determining.....	40
Glycerine .....	120	— low.....	65
— jelly.....	120	Malaria, hæmatozoon of .....	232
Grape-vine, bacteriosis of.....	268	Manipulation, microscopical....16, 40, 67,	99, 120, 146, 167, 195, 287
Grapho prisms, defects in.....	12	Media, acid nutritive.....	290
Grasshopper, H. L. Osborn .....	279	Medical microscopy.....	19, 45, 73, 149
Great Salt Lake, brine shrimp of....	284	Method, carbol-methylen-bluc .....	211
Gregarina gigantea.....	239	Micro-organism .....	19
Griffin, F. W., low powers.....	282	— a pink.....	18
Griffith, E. H.....	150, 290	— cultivating apparatus for .....	289
Gromia oviformis .....	236	— growth of.....	44
Gulland's method of fixing sections...	288	— H. Gibbes .....	141
Gum for labels .....	100	— of the mouth.....	256
— slide labels .....	197	Micro-photography, camera for .....	39
Hæmatozoon of malaria.....	232	Microscope.....	96
Hair, examination of.....	191	— all-around, S. A. Forbes.....	91
Hastings, W. N., desmids from N. H.	153	— an electric.....	150
— new desmid.....	29	— bacteriological star.....	98
— to collect desmids.....	113		

	PAGE.
Microscope, detecting crime with.....	68
— dissecting.....	2
— Edinburgh student's.....	219
— in diagnosis.....	45
— in pharmacy.....	49, 89, 262
— lamp.....	286
— Leidy's.....	174
— pocket, L. E. Sayre.....	95
— teaching with.....	147
— use of compound.....	89
Microscopical Exposition at Antwerp	
— illustrations, H. L. Tolman.....	133, 157
— news, 20, 46, 74, 103, 150, 174.....	220, 290
<b>MICROSCOPICAL SOCIETIES :</b>	
Austin, Texas.....	22
Calcutta, India.....	75
Iron City, Pa.....	127
Lincoln Microscopic Club, 198, 247, 292	
Montreal, Canada.....	23, 126
New Jersey State.....	128
New York, N. Y.....	76, 128
Nyack Association.....	199
Omaha, Neb.....	127
Postal Club.....	291
Queckett Club.....	223
Royal, London.....	22
St. Louis Club, 22, 104, 126, 152, 247, 291	
San Francisco, 21, 74, 104, 152, 175, 221, 268	
Washington, D. C.....	22, 126, 151, 200
Microscopy, American.....	14
— at Columbian Exposition.....	74
— for the druggist.....	149
— is a science.....	190
— recreative.....	13, 46, 72, 125
Microtome, a cheap.....	195
— Taylor's freezing.....	25
Milk.....	47
— Boston supply.....	102
— Pasteurized.....	124
— souring of.....	44
Minerals, microscopic determination of.....	220
— mounts of.....	125
Mole, newly discovered.....	70
Moore, V. A., staining flagella.....	3
Mounting clip, pressureless.....	166
— fluid, a new.....	16
— medium, Shimer's.....	110
— opaque objects.....	41
— radiolaria.....	64
— spirostomum.....	68
— stentors.....	68
— trichinæ.....	197
— tubercle bacilli.....	41
Mounts of minerals.....	125
Mouth, micro-organisms of.....	256
<b>NEW PUBLICATIONS (See notices of books):</b>	
Noctiluca miliaris.....	237

**NOTICES OF BOOKS :**

	PAGE.
Annual Address, President Richards.....	292
Artesian Horizons in N. J.....	128
Atlantic Monthly.....	176
B. & L. Catalogue.....	248
Catalogue of Williams & Norgate.....	128
Die Botanische Mikrotechnik.....	200
Epidemic of Quackery.....	152
Essentials of Bacteriology.....	24
Essentials of Medical Physics.....	48
General Bargain List.....	128
Hypodermic Medication.....	248
Ledger Almanac.....	48
Living Matter.....	224
McI. B. & O. Co.'s catalogue.....	79
Microscope.....	76
Newer Materia Medica.....	272
Of the Teeth.....	292
Outlines of Entomology.....	223
Plant Organization.....	48
P. Terenti Afri Heavton Timor.....	79
P. Terenti Afri Phormio.....	79
Queen's Catalogue.....	292
Quintus Curtius.....	79
Report of Postmaster-General.....	48
Sanitarian.....	24
School and College.....	24
Stricture of the Rectum.....	48
Supreme Passions of Man.....	200
Surgical Treatment.....	47
Treatment of Eye Diseases.....	224
Tobacco and Insanity.....	48
Vegetable Plant.....	48
Vick's Floral Guide.....	47
Notops clavulatus.....	278
— minor.....	273
Objectives, cleaning.....	99
— cleaning homogeneous.....	86
— handling.....	287
— magnifying power of, H. L. Tolman.....	93
— new.....	98
— oil-immersion.....	146
— to clean.....	40
— using oil-immersion.....	288
Objects, mounting opaque.....	41
— shading.....	86
O'Connor, J. T., refractometer.....	181
Oculars, cleaning.....	99
Obituary notices.....	172
Organisms, apparatus for controlling living.....	30
OSBORN, H. L., elementary biology.....	9, 26
— Grasshopper.....	279
— Imbedding animal tissues.....	116
— Studies in biology.....	87, 105
— The protozoa.....	233
Osmic acid.....	110
Paper for cleaning lenses.....	99
Paraffin.....	132
— imbedding in.....	116
— sections fixing.....	288
Paramecium aurelia.....	238
Parasites, elm.....	18

	PAGE.		PAGE.
Parasites, malaria .....	17	Smiley, C. W., Leeuwenhoek Micro-	210
— of fishes .....	71	scopical Club.....	
Parsons, F. A., rotifers.....	277	Smiley, R. W., American Microscop-	201
Pasteur institute.....	149	ical Society .....	
Pengra, C. P.....	74	Soirées.....	72
Peridinium uberrimum.....	237	Specimens, biological .....	42
Pharmacy, microscope in.....	49, 89, 262	— preserving botanical.....	42
Philogina .....	279	Spirostomum, mounting .....	68
Photo-micrographs of diatoms.....	67	Sponges, fresh water.....	70
Photo-micrography.....	67, 158	— preparing.....	146
Plants, cell walls of.....	129	Sputum, decolorizing bacillus obtained	
— insectivorous .....	41	from.....	268
Polarizer, a new.....	15	— examination of.....	170
Potato, bacterial disease of.....	124	Staining .....	117
— biological study of.....	87, 105	— flagella, V. A. Moore.....	3
Preparations .....	161	— Gabbet's process .....	171
— cover-glass.....	172	Staurastrum megalonotum.....	154
Prize essay.....	45	Stentors, mounting.....	68
Protoplasm .....	33	— polymorphus .....	238
— continuity of, W. J. Beal and J.		Sterilizer, convenient.....	192
W. Toumey.....	129	— nice .....	39
— poisoning.....	146	Street-dust, bacteria in.....	102
Protozoa, H. L. Osborn.....	233	Sturgeon in Idaho.....	121
Pyxicola affinis.....	238	Sugar-cane diseases.....	18
Quinine, poisoning with.....	146	Sweating.....	149
Radiolaria, F. B. Carter.....	63, 111, 143, 177, 216, 257	Sweet-potato blossoms.....	41
— mounting .....	64	Table, revolving.....	120
Radish .....	17	Talmage, J. E., brine shrimp.....	284
Rafter, G. W., examination of po-		Taylor, Dr. Thomas.....	150
table water.....	55	— microtome.....	25
Refraction, index of, A. B. Aubert.....	225	Terry, W. A., diatoms of Conn. 185,	230,
Refractometer, J. T. O'Connor.....	181	253	
Rhizopod, C. W. Smiley.....	51	Tissues, hardening .....	116
Rotalia .....	236	TOLMAN, H. L.....	65, 174
Rotifer elongatus.....	12	— Magnifying power of objectives.....	93
— notes.....	12, 273	— Microscopical illustrations .....	155
Rousselet, C., rotifers.....	273	— Notice of W. H. Bulloch.....	29
Saliva, human.....	256	Toumey, J. W., continuity of proto-	
Salmon in Idaho.....	121	plasm.....	129
Sand, to mount dry.....	41	Trichina .....	45
Sayre, L. E., pocket microscope.....	95	Trichinae, mounting .....	197
Schultze, E. A., microscopical appa-		Triphylus lacustris .....	278
raturs.....	30	Tubercle bacilli, examination for.....	170
Science meetings.....	164	— mounting.....	41
— microscopy .....	190	Typhoid, bacillus of.....	19
Scientific names, priority.....	163	Vegetable growth, strength of.....	18
Seal-skin, how prepared.....	147	Vorticella, attachment of.....	101
Sea-weeds, growth of.....	18	Vorticella sp. indet.....	238
Section cutter, potato, C. F. Dawson.	243	Ward, R. H., Antwerp Microscopical	
Sections, cutting.....	117	Exposition.....	133, 157
— fixing paraffin.....	288	Washington, water supply of.....	73
Sectionizing, animal tissues.....	116	Water, chemically pure .....	44
Seeds, growth of.....	70	— examination of potable, G. W.	
— jumping.....	17	Rafter.....	55
Senega .....	101	Watermelon juice.....	42
Sewage .....	103	Weed extermination.....	147
Sex, determination.....	17	Wester, G., rotifers.....	278
Sharp practice.....	20	Whelpley, H. M., microscope in phar-	
Slides, box for.....	166, 198	macy.....	49, 89
— fixing sections to.....	288	Whetstones, to remove oil from.....	256
Smiley, C. W., beautiful rhizopod....	51	White's objects.....	47, 74, 103
— editorial.....	14, 38, 65, 96, 118, 145, 163, 190.	Work, useful .....	72
		Xanthidium truncatum.....	154
		Zentmayer's microscope.....	193
		Zoölogy, study in, H. L. Osborn .....	279







MBL WHOI Library - Serials



5 WHSE 03137

